

AD-A035 006

TEXAS UNIV AT AUSTIN DEFENSE RESEARCH LAB
A VARIABLE BANDWIDTH CONSTANT K FILTER. (U)
JUN 61 6 E OTT

F/6 9/5

UNCLASSIFIED

DRL-A-184

NOBSR-72627

NL

| OF |
AD
A035006



END
DATE
FILMED
3-77

MOST Project - 3

1

12 58p.

11 Jun 61

14 DRL-A-184

6 A VARIABLE BANDWIDTH CONSTANT K FILTER.

by

10 Granville E. Ott

Copy No. 2

DEFENSE RESEARCH LABORATORY
THE UNIVERSITY OF TEXAS
AUSTIN 12, TEXAS

DDC
RECEIVED
DEC 2 1976
A

9
DRL Acoustical Report No. 184

Resulting from research done under Bureau of Ships
Research and Development Contract NObsr-72627
NE 051247-6, NE 051456-4
Problem 8-C

15
DISTRIBUTION STATEMENT A
Approved for public release;
Distribution Unlimited

107500

mit

A VARIABLE BANDWIDTH CONSTANT K FILTER

by

Granville Emil Ott, B.S. in E.E.

THESIS

Presented to the Faculty of the Graduate School of
The University of Texas in Partial Fulfillment
of the Requirements

For the Degree of
MASTER OF SCIENCE
in
Electrical Engineering

THE UNIVERSITY OF TEXAS

June, 1961

ACCESSION for	
NTIS	White Section <input checked="" type="checkbox"/>
GDC	Buff Section <input type="checkbox"/>
UNANNOUNCED	<input type="checkbox"/>
JUSTIFICATION	<i>Not on file</i>
BY	
DISTRIBUTION/AVAILABILITY CODES	
Dist.	AVAIL. and/or SPECIAL
A	



ABSTRACT

The problem consisted of designing a variable bandwidth constant gain filter for use with a superheterodyne pulse receiver capable of receiving ten microsecond and longer pulses. The desired results were achieved by electronically varying the shunt impedance of a three pole constant K filter "T" section. This solution introduced the additional problem of designing a very low output impedance amplifier. A high gain feedback cathode follower is analyzed and designed to meet this problem. The operational characteristics of the variable bandwidth filter and the transient analysis of a constant K filter are included.



PREFACE

This thesis presents the design of a variable bandwidth uniform gain constant K filter for use with a superheterodyne pulse receiver.

The author wishes to express his sincere appreciation to Dr. H. W. Smith and Dr. C. M. McKinney for their aid in suggesting the topic and advice in the preparation of this thesis.

The author also wishes to express his appreciation to the staff of the Sonar Research and Technical Reports Sections of the Defense Research Laboratory for their assistance in the preparation of this thesis. Particular credit is due Messrs. R. H. Wallace, L. D. Hampton and J. G. Cole for their suggestions.

Granville E. Ott

Austin, Texas

May, 1961

TABLE OF CONTENTS

Chapter	Page
I. INTRODUCTION	1
II. USE OF FEEDBACK TO VARY BANDWIDTH	6
III. LOW IMPEDANCE CATHODE FOLLOWER	10
IV. FILTER DESIGN	22
V. OPERATIONAL CHARACTERISTICS	31
VI. SUMMARY AND CONCLUSIONS	44
APPENDIX	45
BIBLIOGRAPHY	52
VITA	53

CHAPTER I

INTRODUCTION

The origin of the problem considered in this thesis was the need for a general purpose pulse receiver to facilitate acoustical studies at the Defense Research Laboratory. The receiver is to be used for displaying pulses on oscilloscopes and for recording the average value of pulses on AC level recorders. It is desired to receive pulses of 10 microseconds and longer in duration.

A high signal to noise ratio requires using the minimum bandwidth which will pass the desired pulse. A wider bandwidth may be necessary in some applications to achieve a shorter rise time. Only a certain amount of filter time delay can be tolerated if the pulse is to be used as a trigger or accurate measure of time delay.

The minimum bandwidth which will pass a pulse with negligible attenuation is discussed in the Appendix. This bandwidth in cycles per second is approximately equal to the reciprocal of the pulse length in seconds. The receiver must have a variable bandwidth in order to achieve optimum reception of various pulse lengths. This requirement is most readily accomplished by using a superheterodyne receiver with a variable bandwidth IF amplifier. In this type of receiver, the input signal is mixed with a signal from a tunable local oscillator to produce a single output frequency for any input frequency. This scheme has the advantage that the amplifier does not have to be tuned, thus providing a constant

gain for any input frequency. Also it is much easier to vary the bandwidth of a filter which is not tunable.

Since the receiver is to be used for calibration purposes, it is desirable to maintain the same gain for various bandwidths of the IF amplifier. The usual methods of varying the bandwidth of bandpass amplifiers, through the use of impedance variation and loading, cause variations in gain; therefore it is desirable to separate the filtering from the stages of gain. Synchronous tuned filters are not desirable in applications requiring wide bandwidths due to the low rate of attenuation caused by the low Q of the tuned circuits. Stagger tuning or other bandpass filter configurations give more rapid rates of attenuation since the Q of each tuned circuit is greater than the ratio of the bandwidth to the center frequency. The Q of synchronous tuned circuits is less than this ratio for the same bandwidth. The overshoot should be kept to a minimum also. This requires a lower Q and thus a lower rate of attenuation.

A three pole constant K bandpass filter was chosen as a good compromise of the above requirements. A constant K filter is an image parameter ladder filter in which the product of the series and shunt impedances is held constant.¹ The configuration may be either a " π " or " T " as shown in Fig. 1. The filter must be terminated by its image impedance to achieve its theoretical characteristics but since this impedance varies with frequency, the filter cannot be properly matched at

¹ W. L. Everitt and G. E. Anner, Communications Engineering (McGraw-Hill Book Company, Inc., New York, 1956), p. 259 ff.

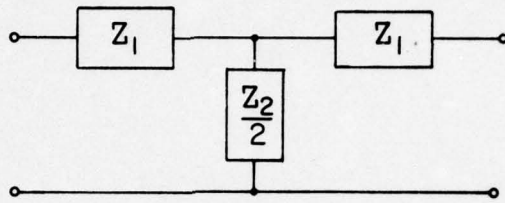

"T" SECTION CONSTANT K FILTER
(a.)

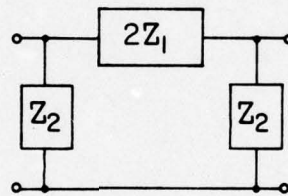

"π" SECTION CONSTANT K FILTER
(b.)

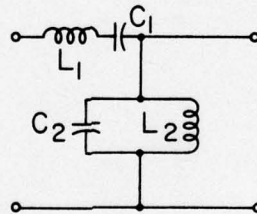

HALF-SECTION BANDPASS CONSTANT K FILTER
(c.)

FIGURE 1
CONSTANT K FILTER CONFIGURATIONS

all frequencies. An approximate match is obtained by using the characteristic impedance of the filter which is the square root of the product of the series and shunt impedance of a half section shown in Fig. 1c. This impedance is equal to the K for which the filter is named.

A constant K bandpass filter has the following relations with definition of symbols in terms of a half section as shown in Fig. 1c.²

L_1 is the series inductance in henrys.

C_1 is the series capacitance in farads.

L_2 is the shunt inductance in henrys.

C_2 is the shunt capacitance in farads.

Z_1 is the series impedance in ohms.

Z_2 is the shunt impedance in ohms.

R is the characteristic impedance in ohms.

ω_1 is the lower 3 db cutoff frequency in radians per second.

ω_2 is the upper 3 db cutoff frequency in radians per second.

$$L_1 C_1 = L_2 C_2 = \omega_1 \omega_2 = \omega_0^2$$

$$\Delta\omega = \omega_2 - \omega_1$$

$$Z_1 Z_2 = R^2 = K^2 = L_1 / C_2 = L_2 / C_1$$

$$L_1 = \frac{R}{\Delta\omega} \tag{1}$$

$$C_1 = \frac{\Delta\omega}{R\omega_0^2} \tag{2}$$

$$L_2 = \frac{R\Delta\omega}{\omega_0^2} \tag{3}$$

$$C_2 = \frac{1}{R\Delta\omega} \tag{4}$$

² Reference Data for Radio Engineers (International Telephone and Telegraph Corporation, New York, 1957), p. 164 ff.

No previous work was found in the literature on bandwidth variation of constant K filters. The impedance variation scheme shown in Chapter II is presented as a unique solution to this problem. The use of feedback for low impedance cathode followers is not new, but the particular arrangement shown in Chapter III is a new extension of this technique as a solution to the second problem involved in this thesis.

CHAPTER II

USE OF FEEDBACK TO VARY BANDWIDTH

Selecting a constant K filter requires that some method be devised to vary the bandwidth while maintaining the same center frequency and gain. Relationships for the bandwidth and characteristic impedance of a constant K filter can be derived from the formulae given in Chapter I.

Solving equations (1) and (3) for R yields:

$$R = \omega_0 \sqrt{L_1 L_2} . \quad (5)$$

Solving equations (1) and (3) for $\Delta\omega$ gives:

$$\Delta\omega = \omega_0 \sqrt{\frac{L_2}{L_1}} \quad (6)$$

Equation (6) shows that the bandwidth can be changed by varying either L_1 or L_2 while changing R to maintain the relation in equation (5).

L_2 can be changed by means of a feedback circuit which changes the shunt impedance of the filter.^{3,4} Figure 2a shows a feedback circuit which will accomplish this. It is assumed that no grid current flows in the amplifier of gain A. The other symbols used in the analysis of the feedback circuit are:

³ J. Markus and V. Zeluff, Electronics for Communications Engineers, (McGraw-Hill Book Company, Inc., New York, 1952), p. 8.

⁴ H. J. Reich, "The Use of Vacuum Tubes as Variable Impedance Elements," Proceedings of the IRE, Vol. 30, June, 1942, p. 288.

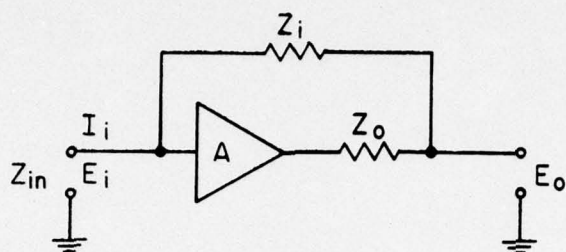

IMPEDENCE CHANGING FEEDBACK AMPLIFIER CURCUIT

(a)

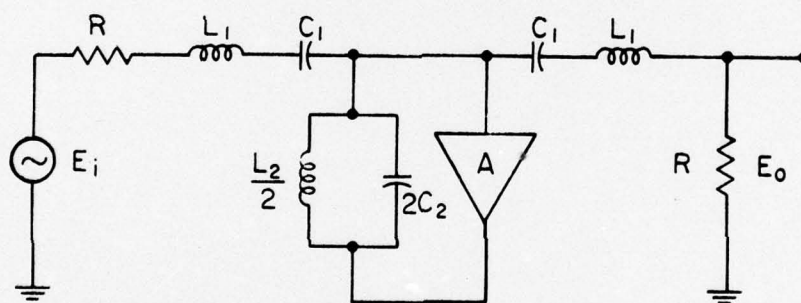

CONSTANT K FILTER CIRCUIT WITH FEEDBACK AMPLIFIER

(b)

FIGURE 2
FEEDBACK VARIATION OF IMPEDANCE AND FILTER BANDWIDTH

Z_{in} is the circuit input impedance,
 Z_o is the amplifier output impedance,
 Z_i is the initial impedance to be varied,
 E_i is the circuit input voltage,
 E_o is the amplifier output voltage, and
 I_i is the circuit input current.

Calculating the input impedance:

$$Z_{in} = \frac{E_i}{I_i},$$

$$I_i = \frac{E_i - E_o}{Z_i},$$

$$E_o = AE_i - I_i Z_o,$$

$$I_i = \frac{E_i (1-A) + I_i Z_o}{Z_i},$$

$$Z_{in} = \frac{Z_i - Z_o}{1-A}. \quad (7)$$

If Z_o is small compared with Z_i then equation (7) becomes equation (8).

$$Z_{in} = \frac{Z_i}{1-A} \quad (8)$$

If A is negative the input impedance will be decreased. If A is positive and less than unity the input impedance will be increased. The low output impedance of the amplifier effectively grounds one side of Z_i , requiring the shunt impedance of the filter to be varied rather than the series impedance.

Figure 2b shows a feedback amplifier employed with a "T" section constant K filter. A "T" section requires only one amplifier to vary the

bandwidth. The bandwidth is varied by changing both A and R so as to maintain the proper relations for a constant K filter. Since an increase in impedance causes an increase in inductance, a negative gain will reduce the bandwidth while a positive gain less than unity will increase the bandwidth.

CHAPTER III

LOW IMPEDANCE CATHODE FOLLOWER

The wide bandwidth filter needed for pulse reception calls for an increase in the initial bandwidth of the filter, thus requiring A to be positive and less than unity. The amplifier must also have a very low output impedance to maintain the desired filter characteristics.

This requirement is met usually by a cathode follower. The conventional cathode follower shown in Fig. 3a has an output impedance approximately equal to the reciprocal of the transconductance of the tube, which may be as low as 100 ohms for a high transconductance tube. The output impedance must be much lower than this value if a large variation of the shunt impedance is to be obtained; therefore the use of one or more conventional cathode followers in parallel is not feasible.

A high gain feedback loop can be used to lower the cathode follower output impedance. A circuit to accomplish this by the series arrangement of two tubes is shown in Fig. 3b.⁵ The gain and output impedance of the circuit is analyzed with the aid of signal flow diagrams.⁶ Figure 4 shows the equivalent circuit and signal flow diagrams for calculating the open circuit gain.

⁵ C. M. Hammack, "Cathode Follower of Very Low Output Resistance," Electronics, Vol. 19, No. 11, November, 1946, p. 206.

⁶ J. G. Truxal, Automatic Feedback Control System Synthesis (McGraw-Hill Book Company, Inc., New York, 1955), p. 88 ff.

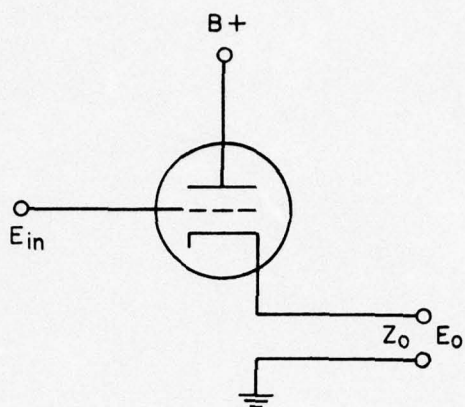

CONVENTIONAL CATHODE FOLLOWER CIRCUIT
(a)

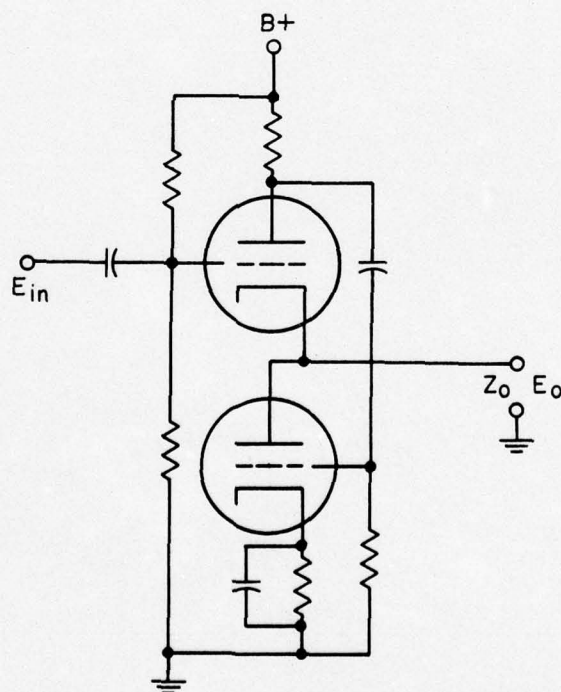

LOW IMPEDANCE CATHODE FOLLOWER CIRCUIT
(b)

FIGURE 3
CATHODE FOLLOWER CIRCUITS

The following symbols are used:

E_{in} is the input voltage.

E_o is the output voltage.

E_{gk_1} is the grid to cathode voltage of the upper tube.

E_{gk_2} is the grid to cathode voltage of the lower tube.

E_{p_1} is the plate voltage of the upper tube.

E_{p_2} is the plate voltage of the lower tube.

E_{k_1} is the cathode voltage of the upper tube.

$$E_o = E_{k_1} = E_{p_2}.$$

I is the series current through the circuit.

μ_1 is the gain of the upper tube.

μ_2 is the gain of the lower tube.

r_{p_1} is the plate resistance of the upper tube.

r_{p_2} is the plate resistance of the lower tube.

Z_1 is the combined plate and grid circuit load impedance of the upper tube.

$$Z_T = Z_L + r_{p_1} + r_{p_2},$$

$$K = -\mu_1 E_{gk_1} - \mu_2 E_{gk_2}.$$

G_v is the open circuit output voltage divided by the input voltage.

G_i is the short circuit output current divided by the input voltage.

I_{sc} is the output short circuit current.

Z_o is the output impedance.

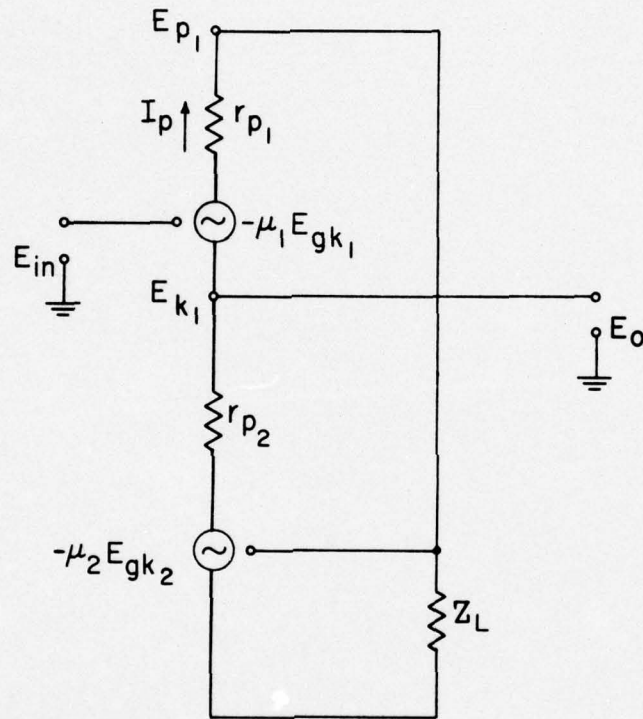
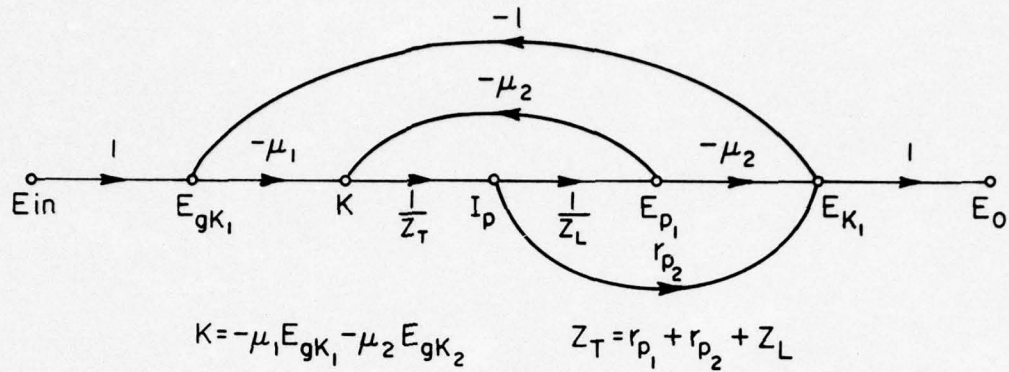
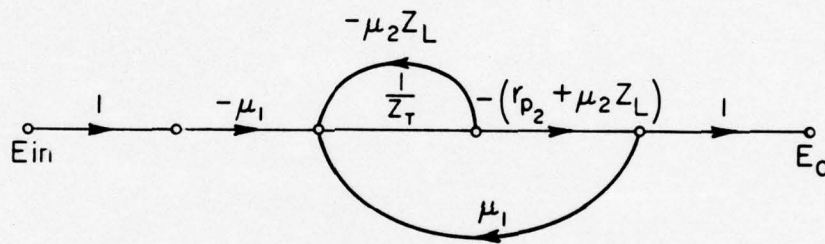

FIGURE 4a
EQUIVALENT CIRCUIT FOR OPEN CIRCUIT GAIN
CALCULATION OF LOW IMPEDANCE CATHODE FOLLOWER



SIGNAL FLOW DIAGRAM



FIRST SIMPLIFICATION

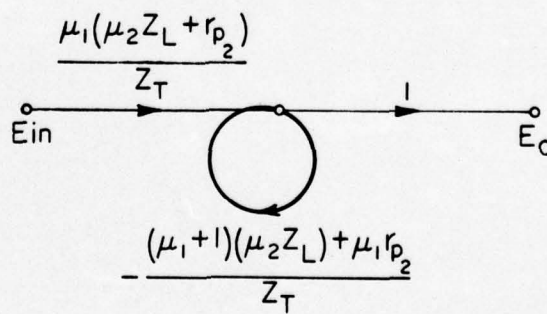

SIMPLIFIED DIAGRAM

FIGURE 4b
 SIGNAL FLOW DIAGRAMS FOR OPEN CIRCUIT GAIN CALCULATION
 OF LOW IMPEDANCE CATHODE FOLLOWER

The transmission is indicated above each branch and the variable under each node of the signal flow diagram. In the simplified diagrams the inner nodes lose their meaning thus are not labeled. Signal flow analysis is a systematic methods for determining the transfer function of a circuit utilizing the transmission between points. These points, called nodes, may be either actual points in the circuit or points created for simplification of analysis. The signal flow diagram shown in Fig. 4b is drawn from the equivalent circuit shown in Fig. 4a. The first signal flow simplification is created by moving the feedback loops and combining the forward parallel paths. The final simplified diagram is obtained by combining the feedback loops and the forward transmittances. The transfer function G_V is equal to the forward transmittance divided by one minus the feedback transmittance.

$$G_V = \frac{\frac{\mu_1(\mu_2 Z_L + r_{p2})}{Z_T}}{1 + \frac{(\mu_1 + 1)(\mu_2 Z_L) + \mu_1 r_{p2}}{Z_T}},$$

or

$$G_V = \frac{\mu_1(\mu_2 Z_L + r_{p2})}{(\mu_1 + 1)(\mu_2 Z_L) + \mu_1 r_{p2} + Z_T} \quad (9)$$

The output impedance of this circuit may be calculated by dividing the open circuit voltage by the short circuit current. In order to calculate the short circuit current, a new equivalent circuit is drawn with the output shorted shown in Fig. 5a. The shorted output eliminates the feedback simplifying the signal flow diagram as shown in Fig. 5b. G_1 is the product of all of the transmittances.

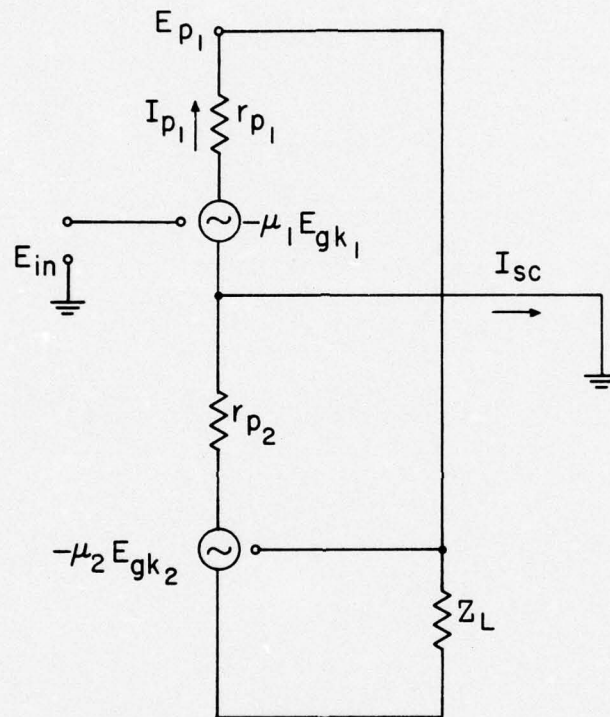
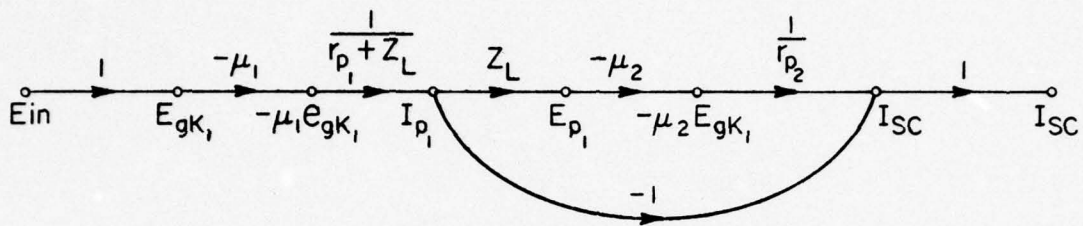
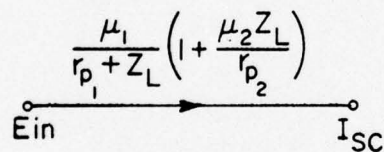

FIGURE 5a

EQUIVALENT CIRCUIT FOR SHORT CIRCUIT CURRENT
CALCULATION OF LOW IMPEDANCE CATHODE FOLLOWER



SIGNAL FLOW DIAGRAM



SIMPLIFIED DIAGRAM

FIGURE 5b
 SIGNAL FLOW DIAGRAMS FOR SHORT CIRCUIT CURRENT CALCULATION
 OF LOW IMPEDANCE CATHODE FOLLOWER

$$G_i = \frac{\mu_1}{r_{p1} + Z_L} (1 + \mu_2 Z_L / r_{p2}) ,$$

$$G_i = \frac{\mu_1 (\mu_2 Z_L + r_{p2})}{r_{p2} (r_{p1} + Z_L)} . \quad (10)$$

Knowing G_v and G_i the output impedance may be calculated:

$$Z_o = G_v / G_i ,$$

$$Z_o = \frac{r_{p2} (r_{p1} + Z_L)}{(\mu_1 + 1)(\mu_2 Z_L) + \mu_1 r_{p2} + Z_T} . \quad (11)$$

Using the two sections of a 12AT7 for the upper and lower tubes, an output impedance of 7 ohms was achieved. A pentode may be used as the upper tube and two parallel triode sections for the lower tube to obtain an even lower output impedance. This raises μ_1 and lowers r_{p2} . Equations (9) and (11) can be used to express the gain and output impedance if the screen grid of the pentode is bypassed to the cathode. In this case the product of the plate resistance and the transconductance of the pentode is used for μ_1 , and half the plate resistance of one triode section is used for r_{p2} .

In the feedback application, it is not desirable to bypass the screen grid to the cathode since this increases the capacity reflected into the shunt impedance, detuning the filter. For this same reason, a voltage divider is used to bias the upper tube rather than a bypassed cathode resistor. Some small change in the center frequency can be noticed from the response curves of different bandwidths shown in Fig. 10, Chapter V.

In order to calculate the effect of bypassing the screen grid of the pentode to ground, the equivalent circuit is modified as shown in Fig. 6a. The screen grid is assumed to drive another generator with an output of the screen to cathode voltage times the effective gain of the screen, $E_{sk}\mu_s$. The screen grid transconductance can be determined from the pentode screen grid transfer characteristics. The effective gain of the screen is $\mu_s r_{p1}$ since both generators are assumed to be in series with the plate resistance of the pentode.

Figure 6b shows the new signal flow diagram and simplifications. The resulting voltage transfer function, G'_v , is:

$$G'_v = \frac{\mu_1(\mu_2 Z_L + r_{p2})}{(\mu_1 + \mu_s + 1)(\mu_2 Z_L) + r_{p2} \mu_1 + Z_T} \quad (12)$$

Since the cathode is shorted to ground to calculate the short circuit current, equation (10) is still applicable. Again the output impedance is the open circuit voltage divided by the short circuit current:

$$Z'_o = \frac{r_{p2}(r_{p1} + Z_L)}{(\mu_1 + \mu_s + 1)(\mu_2 Z_L) + r_{p2} \mu_1 + Z_T} \quad (13)$$

The gain and output impedance are slightly reduced by the μ_s factor.

Since μ_1 is large and r_{p2} small, the following approximate relations for

the gain and output impedance are valid:

$$G'_v = \frac{\mu_1}{\mu_1 + \mu_s}, \quad (14)$$

$$Z'_o = \frac{r_{p2}(r_{p1} + Z_L)}{(\mu_1 + \mu_s)(\mu_2 Z_L)} \quad (15)$$

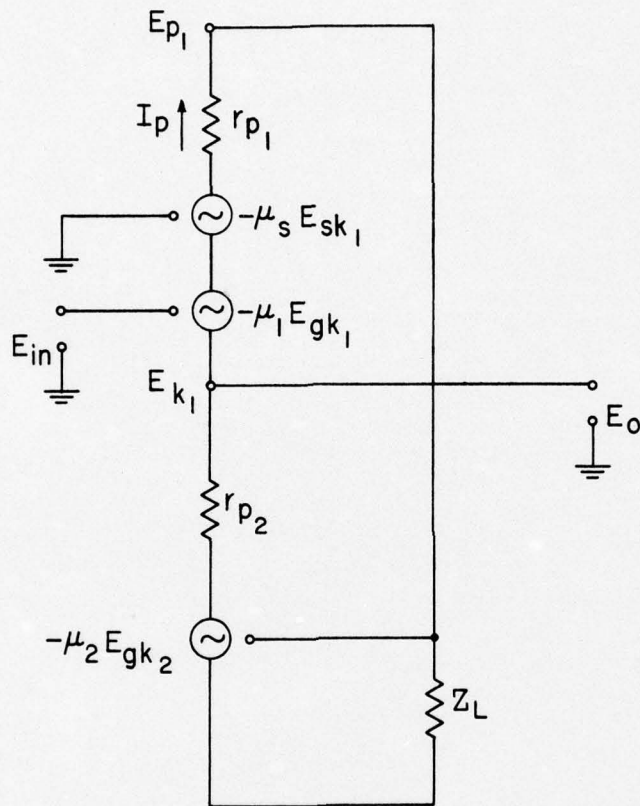
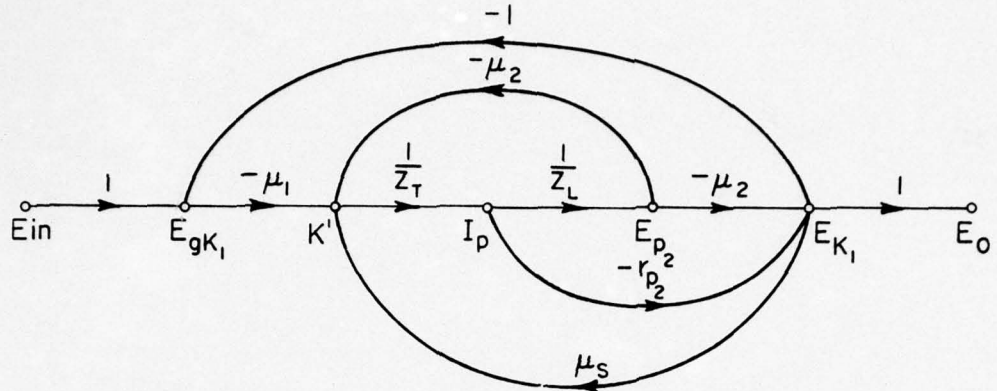

FIGURE 6a

EQUIVALENT CIRCUIT FOR OPEN CIRCUIT GAIN
 CALCULATION OF LOW IMPEDANCE CATHODE FOLLOWER
 USING A PENTODE AS THE UPPER TUBE



$$K' = -\mu_1 e_{gK_1} - \mu_s e_{SK_1} - \mu_2 e_{gK_2} \quad Z_T = r_{p_2} + Z_L$$

SIGNAL FLOW DIAGRAM

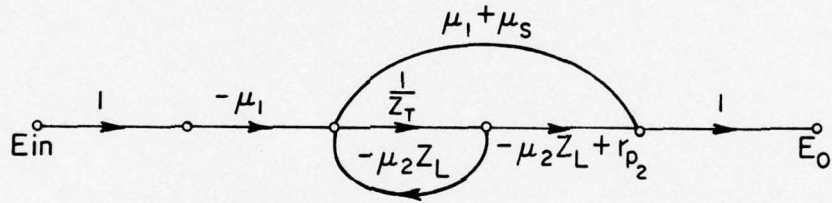

FIRST SIMPLIFICATION

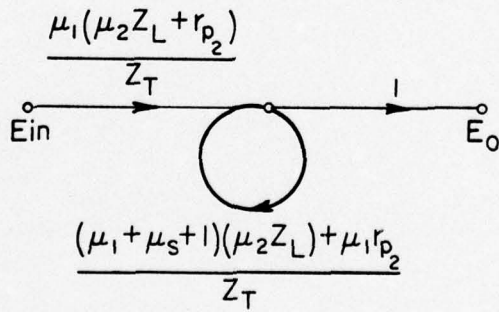

SIMPLIFIED DIAGRAM

FIGURE 6b
SIGNAL FLOW DIAGRAMS FOR OPEN CIRCUIT GAIN
CALCULATION OF LOW IMPEDANCE CATHODE
FOLLOWER USING A PENTODE AS UPPER TUBE

CHAPTER IV

FILTER DESIGN

The center frequency of the filter must be low enough for use with conventional AC level recorders and yet high enough to permit a 100 kc bandwidth. The frequency must also be high enough to allow at least two cycles of the shortest pulse to be received. A 200 kc center frequency was chosen considering the use of the receiver with recorders such as the Bruel and Kjaer Model 2305B receiving pulses as short as 10 μ sec.

The narrowest bandwidth must be sufficiently small to effectively suppress the undesired signals when using long pulses. The minimum bandwidth of the filter is limited by the maximum series inductance and the minimum shunt inductance that can be built with a Q sufficiently high to achieve the desired filter characteristics. The minimum Q for a maximum-ally flat three pole ladder filter is two times the ratio of the center frequency to the 3 db bandwidth.⁷

The shunt inductance must have a reactance large enough to maintain a sufficiently high Q with the output impedance of the amplifier. With an output impedance of 1.5 ohms and a center frequency of 200 kc., the minimum inductance for any Q can be determined, not considering coil loss, by $Q = \frac{\omega L}{R_o}$.

⁷ Reference Data for Radio Engineers (International Telephone and Telegraph Corporation, New York, 1957), p. 194.

Solving for L:

$$L = \frac{QR_o}{\omega} ,$$

$$L = \frac{1.5Q}{2\pi(2 \times 10^5)} . \quad (16)$$

The self resonant frequency of the series inductance must be far enough above the center frequency of the filter to permit linear operation over the pass band of the filter. Using small ferrite pot cores, inductors as large as 10 mh can be used at 200 kc.

Choosing a 20 kc bandwidth gives a minimum shunt inductance of 24 μ h from equation (16). A "T" section filter configuration was chosen to permit the use of only one low impedance amplifier. Allowing for internal loss in the coil and the fact that the shunt coil of a "T" section must be one half of L_2 , L_2 was chosen to be 80 μ h. The bandwidth inductance relation given in equation (6) requires 8 mh for L_1 . Equation (5) gives an initial characteristic impedance of 1000 ohms.

The circuit for the low impedance amplifier is shown in Fig. 7. A 33,000 ohm plate resistor is used since the shunt impedance due to the output capacity of the 6AU6 plus the input capacity of the parallel sections of the 12AT7 and the stray wiring capacity is about 40,000 ohms. This gives a Z_L of about 25,000 ohms. The plate voltage of the 12AT7 is adjusted to be 75 volts by the voltage divider on the grid of the 6AU6.

Tube data were taken from the General Electric tube manual.⁸ The operating point of the 6AU6 was set for a plate current of 5 ma and a screen voltage of 100 volts. This allowed a screen current of 1.8 ma

⁸ Electronic Tubes (General Electric Company, Schenectady, New York, 1950).

which required the 12AT7 to be biased to flow 6.8 ma. This is 3.4 ma per section which is obtained with a 68 ohm cathode bias resistor.

Under the above operating conditions the grid-to-plate transconductance of the 6AU6 is 3900 μ mhos, and the screen-to-plate transconductance is 100 μ mhos. With a plate resistance of 500,000 ohms μ_1 is 1950, and μ_s is 50.

The low voltage characteristics for the 12AT7 were taken from the curves for a 6AB4 which is a single section equivalent tube with low voltage data. The gain of the 12AT7, μ_2 , is 60. The plate resistance per section is 15,000 ohms making r_{p2} equal to 7,500 ohms.

Using equations (14) and (15) derived in Chapter III, the gain and output impedance are calculated:

$$G'_v = \frac{\mu_1}{\mu_1 + \mu_s} = \frac{1950}{1950 + 50} = 0.975.$$

The measured gain was 0.98.

$$Z'_o = \frac{r_{p2}(r_{p1} + Z_L)}{(\mu_1 + \mu_s)(\mu_2 Z_L)}$$

$$Z'_o = \frac{7,500(500,000 + 25,000)}{(1950 + 50)(60)(25,000)} = 1.31 \text{ ohms.}$$

The measured output impedance was 1.48 ohms. Care was taken to keep the load current below the cutoff of the tube by using a low input voltage and measuring the open circuit voltage and the loaded voltage where the load resistance was greater than the output impedance. In operation with the filter the amplifier is not loaded.

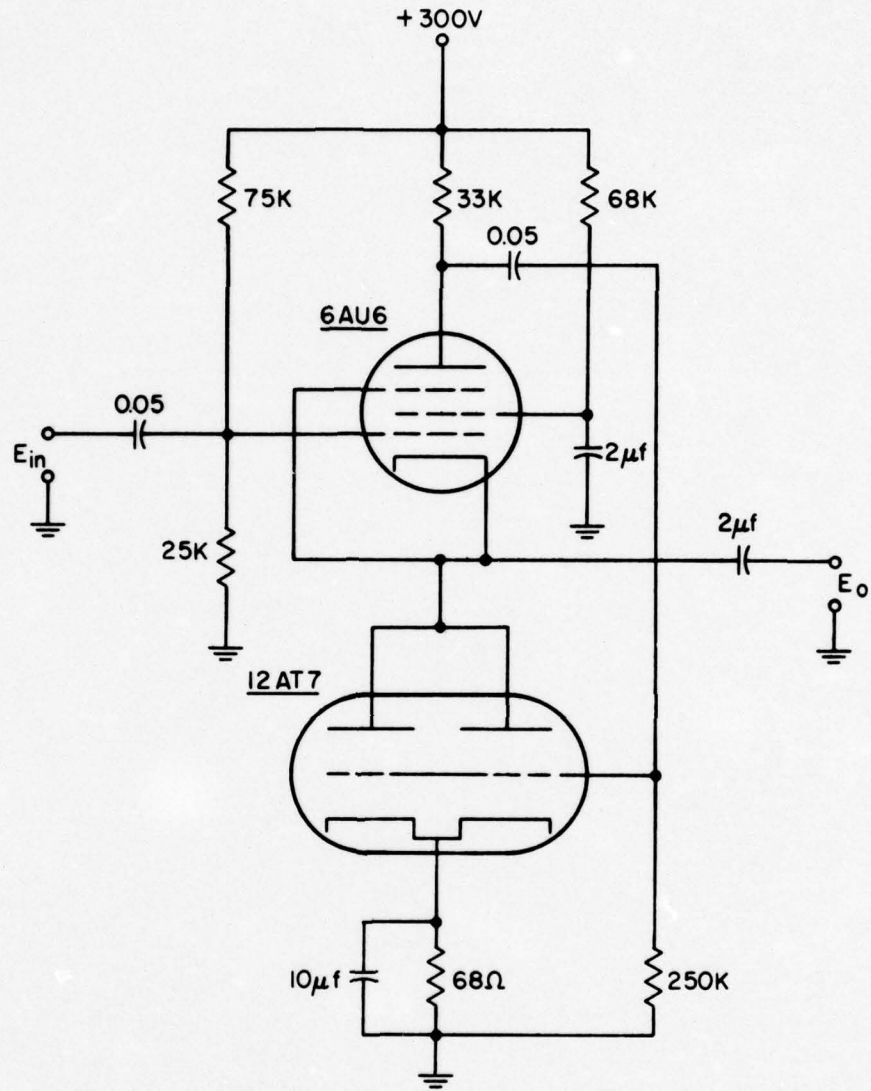

FIGURE 7
CIRCUIT DIAGRAM OF LOW IMPEDANCE CATHODE FOLLOWER

In order to vary the gain of the cathode follower a resistor is used in series with the grid biasing resistors as an attenuator. The biasing resistors were made as small as possible without loading the filter to minimize the effect of stray capacitance. The impedance loading the shunt tuned circuit must be greater than the equivalent parallel resistance for the minimum-Q. The shunt impedance from equation (8) gives:

$$R_g = \frac{Q_0 L}{1-A} \quad (17)$$

Since the inductance must be increased by the square of the bandwidth, the maximum resistance will occur at maximum bandwidth with a minimum Q of 4.

$$R_g = \frac{4(2\pi)(2 \times 10^5)(40 \times 10^{-6})}{1 - 0.98} = 10,000 \text{ ohms.}$$

Using 75,000 ohm and 25,000 ohm resistors in the biasing voltage divider gives an input impedance of 18,000 ohms including the input capacity.

A schematic diagram of the filter is shown in Fig. 8. A ganged switch is used to vary the resistances R_1 , R_2 , and R_3 rather than ganged potentiometers because of the high capacity present in potentiometers and the different functions required of each resistor. An eleven position switch is used with 10 positions dividing up the range of the filter. The eleventh position is left open for any special bandwidth that might be desired. The bandwidths are selected to have an approximate geometric spread from 20 kc to 100 kc using nine positions with the maximum usable bandwidth on the tenth position. Table I shows the bandwidths selected and the values of the resistors.

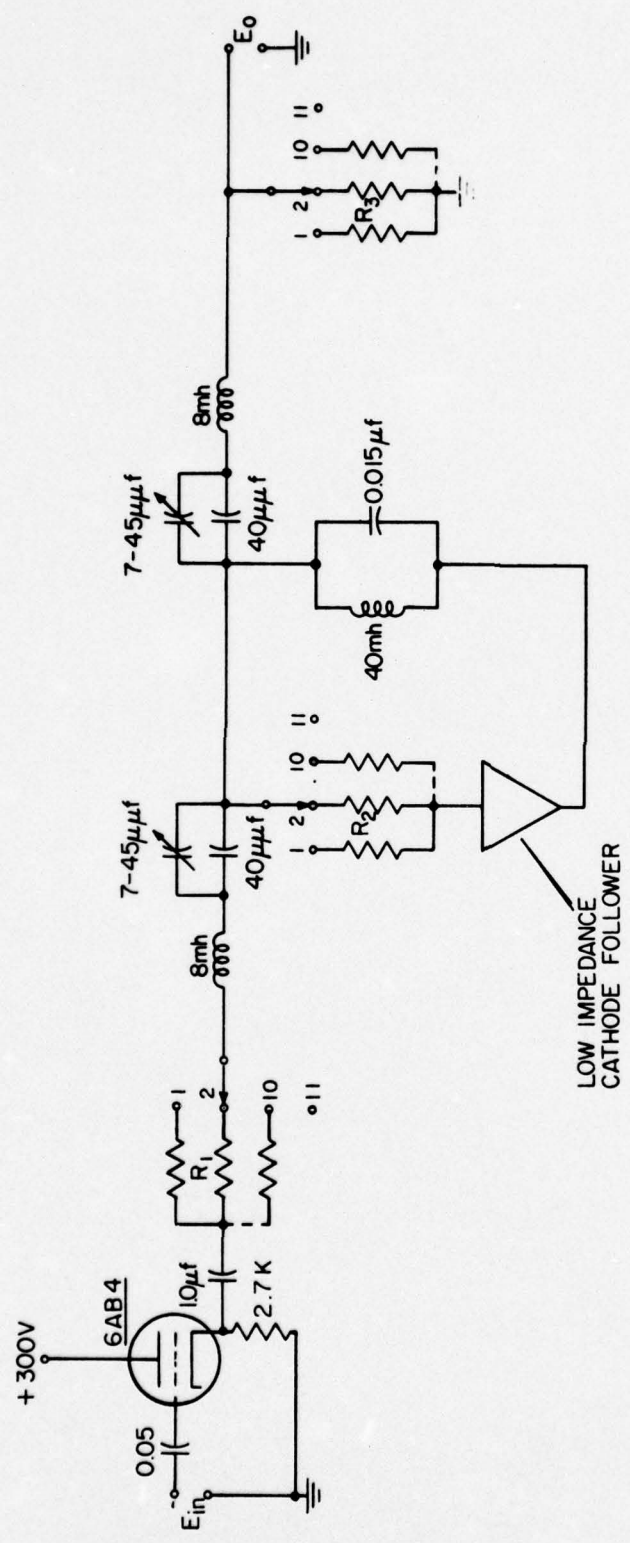

FIGURE 8
VARIABLE BANDPASS FILTER SCHEMATIC

Table I

Switch Position	Δf kc	Calculated Values			Circuit Values			
		R_1 ohms	A	R_2 ohms	R_3 ohms	R_1 ohms	R_2 ohms	R_3 ohms
1	20	250	0	Open	1000	100	Open	1000
2	25	500	0.36	30000	1250	500	33000	1330
3	30	750	0.56	13500	1500	750	15000	1500
4	35	1000	0.67	8300	1750	1000	9100	1780
5	40	1250	0.75	5500	2000	1200	6000	1900
6	50	1750	0.84	3000	2500	1780	3300	2200
7	60	2250	0.89	1800	3000	2200	2200	2500
8	75	3000	0.93	1000	3750	3000	1200	3600
9	100	5250	0.96	375	5000	4700	300	5000
10	140	6250	0.98	0	7000	5600	0	7000

The resistance of R_1 is equal to the initial characteristic impedance of the filter times the desired bandwidth divided by the initial bandwidth minus the effective resistance of the series inductance and the output impedance of the driving cathode follower. With a Q of 40 the effective resistance of the series inductance is 250 ohms. The output impedance of the cathode follower is 500 ohms.

$$R_1 = \frac{1000 \Delta f}{20,000} - 750 . \quad (18)$$

The resistance of R_2 is chosen to give the desired gain with the 18,000 ohm input impedance of the amplifier. The gain is equal to the open circuit gain, G_v' , times the gain of the voltage divider consisting of R_2 and the input resistance.

$$A = \frac{0.98 (18,000)}{R_2 + 18,000} \quad (19)$$

Solving for R_2 :

$$R_2 = \frac{18,000 (0.98 - A)}{A} \quad (20)$$

The value of gain required for a given bandwidth can be determined from equations (5) and (8) derived in Chapter II.

$$\Delta \omega = \omega_o \sqrt{\frac{L_2}{L_1}} \quad (5)$$

The ratio of the increased bandwidth to the initial bandwidth is given in equation (21).

$$\frac{\Delta \omega'}{\Delta \omega} = \frac{\omega_o \sqrt{\frac{L_2}{L_1}}}{\omega_o \sqrt{\frac{L_2}{L_1}}} . \quad (21)$$

Solving for L_2' :

$$L_2' = \left(\frac{\Delta\omega}{\Delta\omega_1}\right)^2 L_2 . \quad (22)$$

Equation (22) represents equation (8) in terms of the effective inductance.

L_2' is the increased inductance and L_2 the initial inductance.

$$L_2' = \frac{L_2}{1 - A} . \quad (23)$$

Solving equations (21) and (22) for A:

$$A = 1 - \frac{(\Delta\omega_1)^2}{\Delta\omega} . \quad (24)$$

The value of gain given by equation (24) is used in equation (18) to determine R_2 .

The characteristic impedance of the filter given by equation (5) is used for R_3 .

$$R_3 = \omega_0 \sqrt{L_1 L_2} \quad (25)$$

Table I shows the calculated values of R_1 , R_2 , and R_3 . Common values of resistance were used in the circuit. The value of R_1 and R_3 was changed when necessary. The values of the resistors used are shown in Table I also.

CHAPTER V

OPERATIONAL CHARACTERISTICS

A filter was built based on the design set forth. The test equipment used to analyze this filter consisted of:

1. Hewlett Packard 650A test oscillator,
2. Ballantine 314 electronic voltmeter,
3. Hewlett Packard 130A oscilloscope,
4. General Radio 1217A unit pulser,
5. Dumont oscilloscope camera, and
6. DRL-built six diode AC gate.

The shunt inductor was tuned with a fixed mica capacitor. The series inductors were peaked with trimmer capacitors since the required capacitance was small enough to be effected by stray capacity.

The filter can be tuned by observing the time domain frequency response or transient response on an oscilloscope. The frequency response is obtained by applying a short DC pulse to the input of the filter. Figure 9a shows the frequency response of the 20 kc filter position using a 0.5 μ sec. pulse. The length of the response pulse is an indication of the rise time of the filter. The area of the small trailing pulse is an indication of the overshoot. This picture is a representation of the inverse Laplace transform for the filter transfer function. A convolution integral between the frequency response in Fig. 9a and a pulsed carrier gives the pulse response of the filter shown in Fig. 9b.

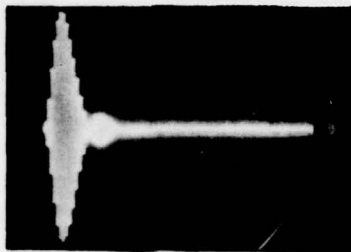

(a)

TIME DOMAIN IN FREQUENCY RESPONSE OF VARIABLE
BANDWIDTH FILTER FOR 20KC BANDWIDTH POSITION

VERTICAL SCALE RELATIVE.

HORIZONTAL SCALE: \longleftrightarrow 50 μ S/DIV.

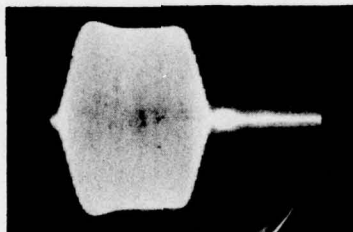

(b)

TRANSIENT RESPONSE OF VARIABLE BANDWIDTH FILTER
FOR 20KC BANDWIDTH POSITION

VERTICAL SCALE RELATIVE.

HORIZONTAL SCALE: \longleftrightarrow 50 μ S/DIV.

FIGURE 9
RESPONSE OF VARIABLE BANDPASS FILTER

This analysis is done mathematically for a low pass equivalent filter in the Appendix. The filter can be tuned for minimum rise time and overshoot while observing the frequency response. Care must be taken to maintain the correct center frequency since no carrier frequency is used. This precaution is not necessary when observing the transient response of the filter to a pulsed carrier.

The steady state frequency of each bandwidth position is plotted in Fig. 10a to Fig. 10k. All of the positions demonstrate typical three pole constant K filter characteristics. The reduction in the attenuation rate of narrow bandwidth positions at higher attenuation levels is caused by the output impedance of the amplifier and the low Q of the inductors. The nonuniformity of the low frequency attenuation for positions 6 and 7 is caused by subharmonics of the center frequency.

Though most of the following discussion on transient response is well known, it is of interest in considering the response of this filter. The response of the filter to a pulsed carrier is not given by the steady state frequency response since a pulse consists of a band of frequencies rather than a single frequency.⁹ The energy of any sharp transient is spread over a wide frequency band resulting in undesired filter output. This effect is not ringing of the filter as in the transmission of the subharmonics. Figure 11 shows the filter output due to the transient of a pulsed carrier in which the carrier frequency is not in the pass band of the filter. In Fig. 11a the carrier is attenuated 20 db with the transient pulse rising 10 db above it. In Fig. 11b the carrier is attenuated 40 db with the transient 18 db above it.

⁹ Reference Data for Radio Engineers (International Telephone and Telegraph Corporation, New York, 1957), p. 1012.

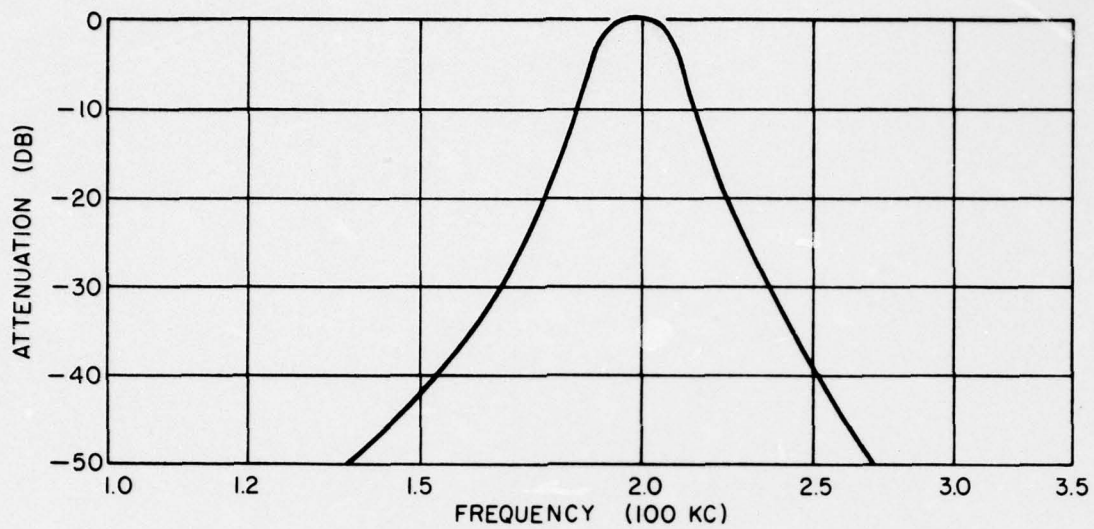

FIGURE 10 a.
FREQUENCY RESPONSE
POSITION 1
20 KC BANDWIDTH

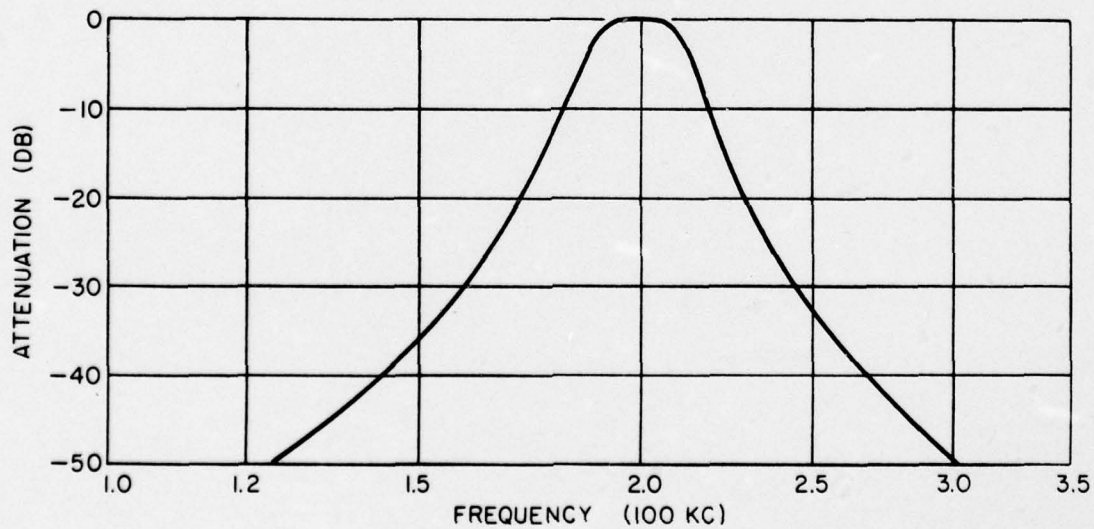

FIGURE 10 b.
FREQUENCY RESPONSE
POSITION 2
25 KC BANDWIDTH

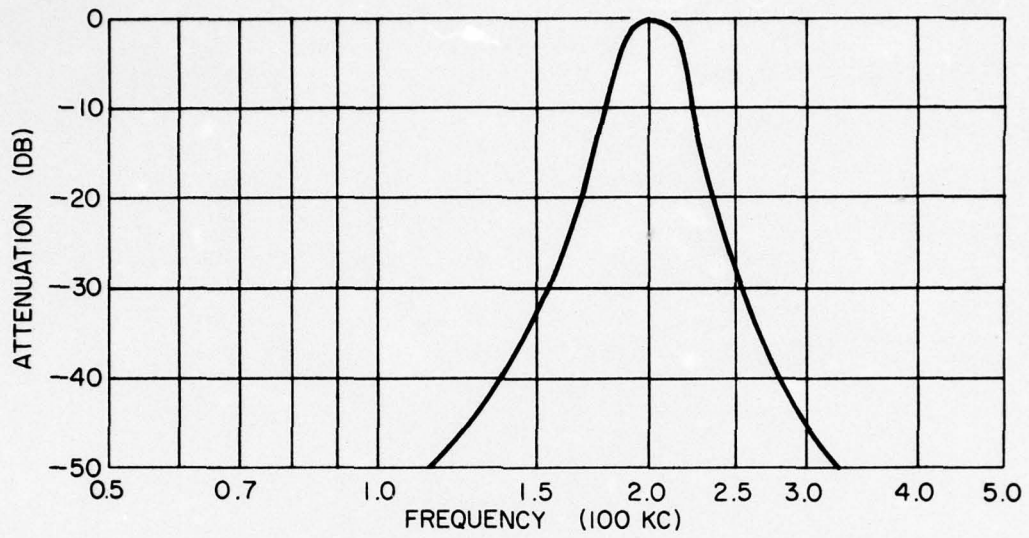

FIGURE 10c
FREQUENCY RESPONSE
POSITION 3
30 KC BANDWIDTH

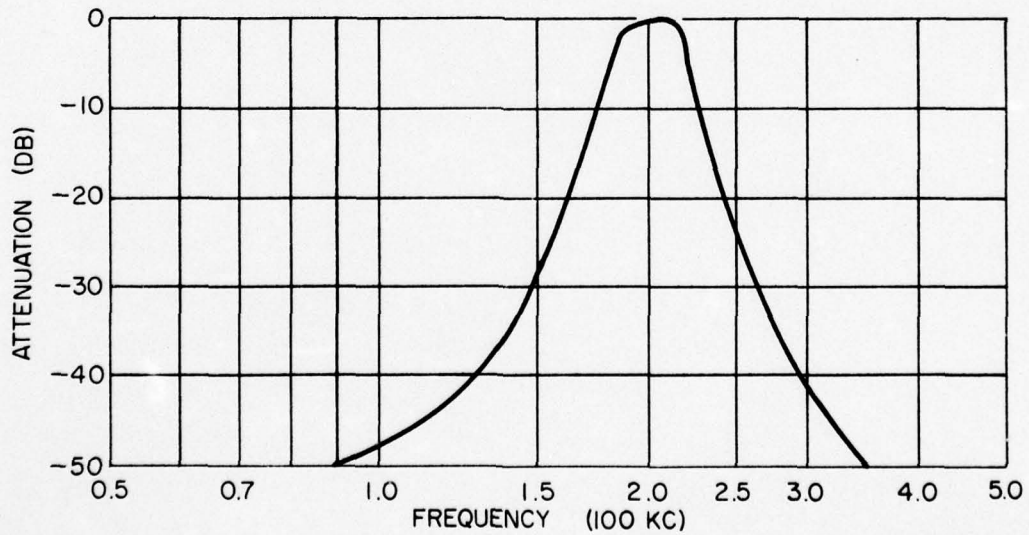

FIGURE 10d
FREQUENCY RESPONSE
POSITION 4
35 KC BANDWIDTH

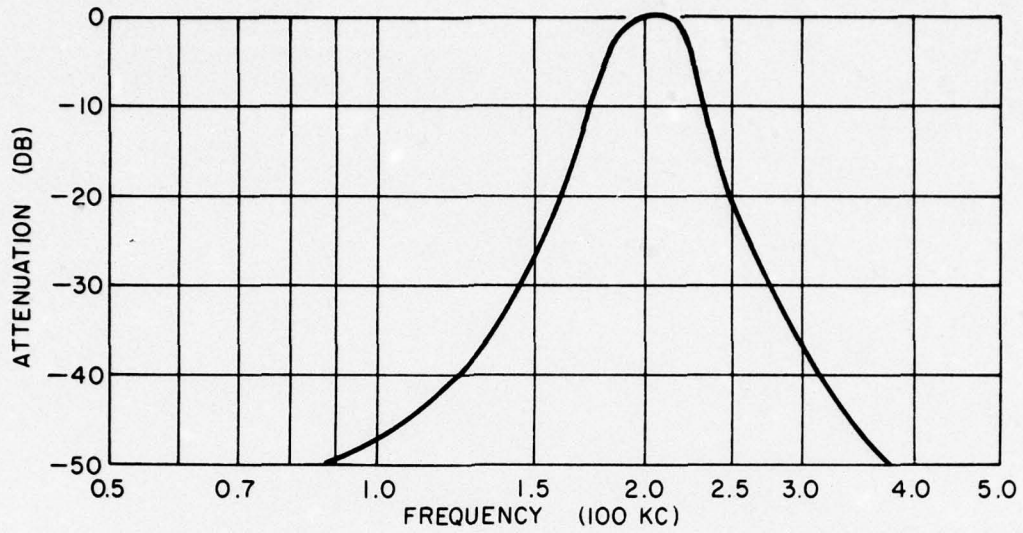

FIGURE 10 e.
FREQUENCY RESPONSE
POSITION 5
40 KC BANDWIDTH

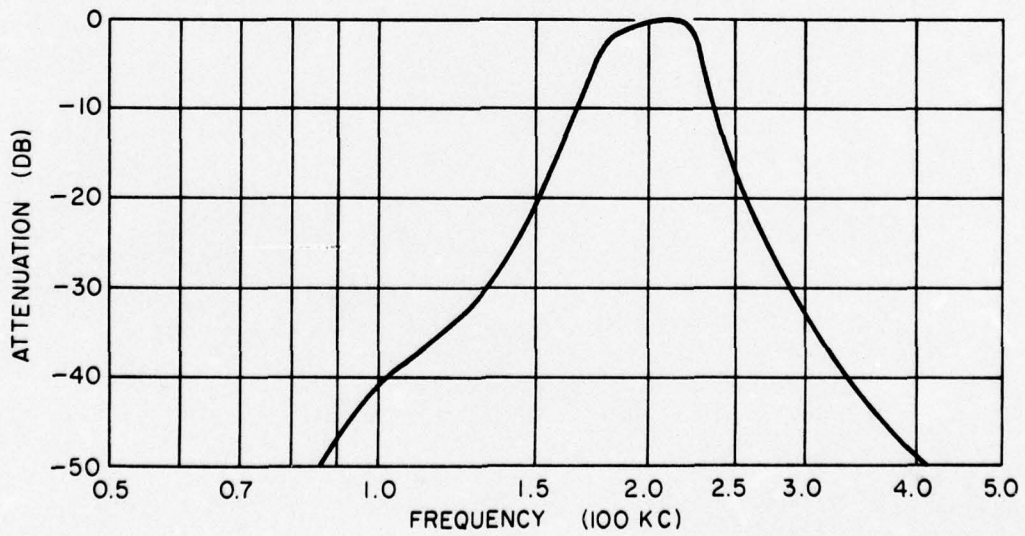

FIGURE 10 f.
FREQUENCY RESPONSE
POSITION 6
50 KC BANDWIDTH

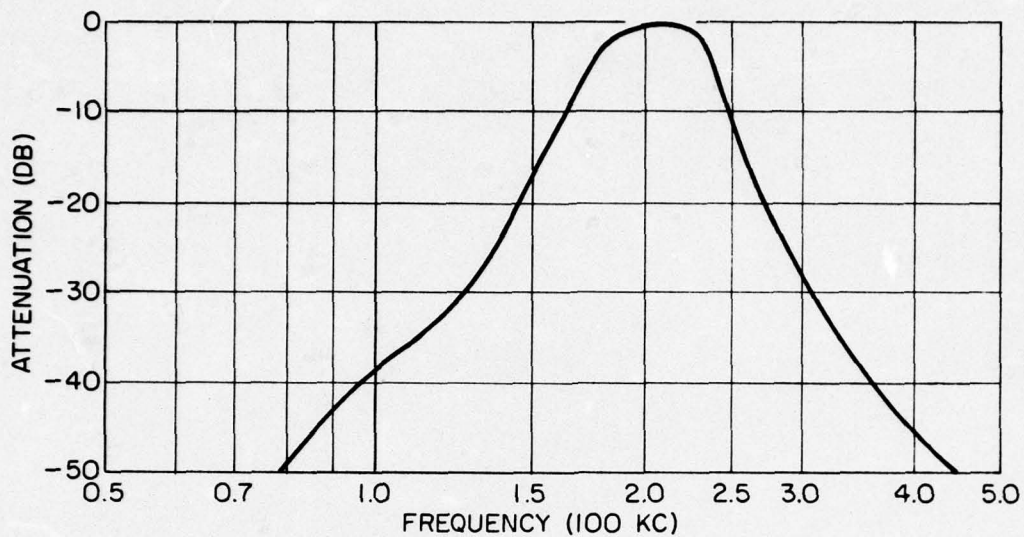

FIGURE 10g
FREQUENCY RESPONSE
POSITION 7
60 KC BANDWIDTH

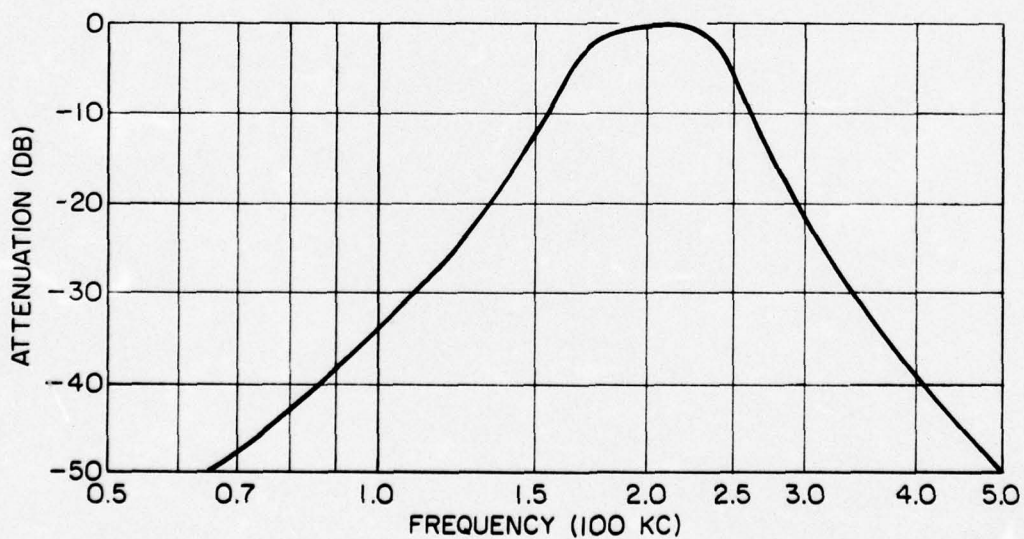

FIGURE 10h
FREQUENCY RESPONSE
POSITION 8
70 KC BANDWIDTH

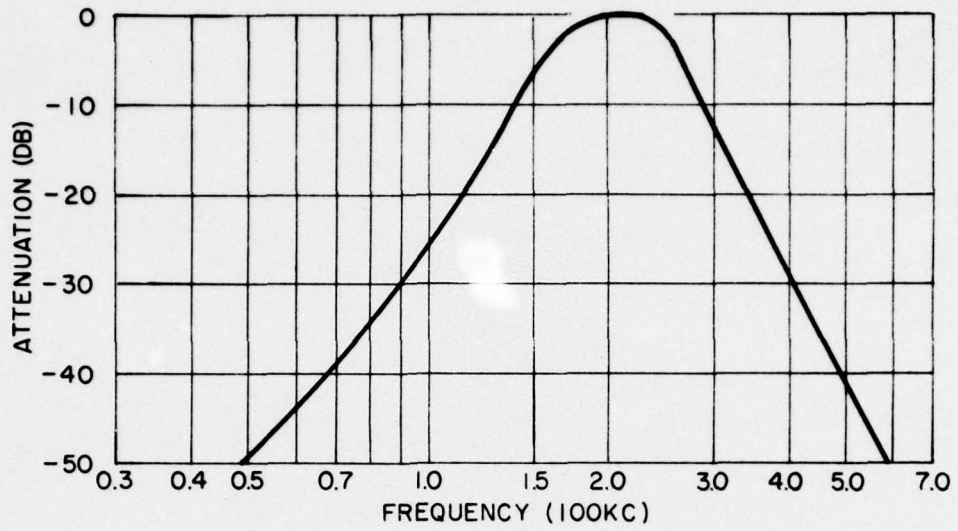

FIGURE 10 j.
FREQUENCY RESPONSE
POSITION 9
20 KC BANDWIDTH

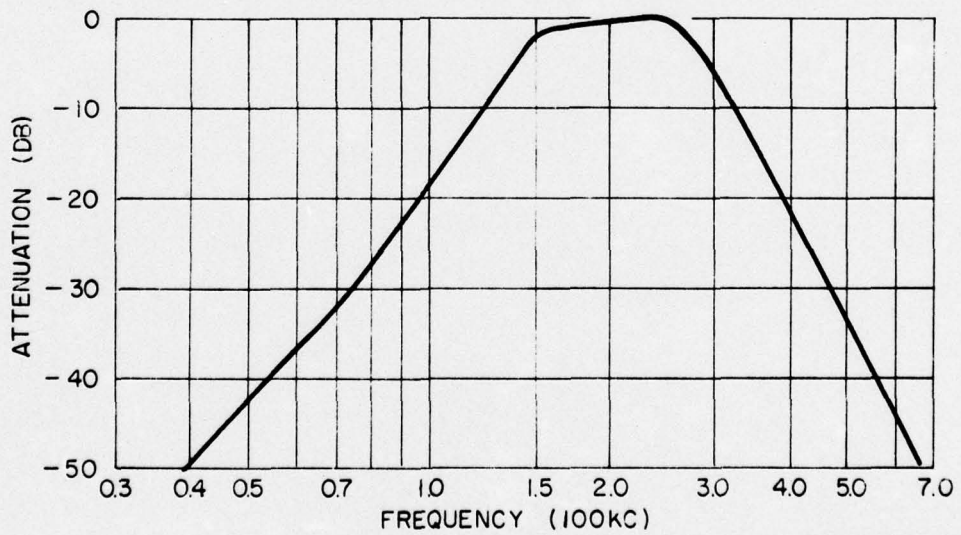
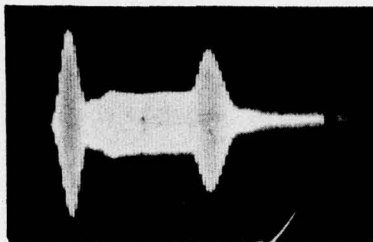

FIGURE 10 k.
FREQUENCY RESPONSE
POSITION 10
20 KC BANDWIDTH



(a)

DETUNED PULSE WITH 20DB CARRIER ATTENUATION

VERTICAL SCALE RELATIVE.

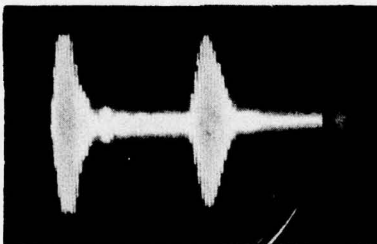
HORIZONTAL SCALE: ———— 50 μ S/DIV.

(b)

DETUNED PULSE WITH 40DB CARRIER ATTENUATION

VERTICAL SCALE RELATIVE.

HORIZONTAL SCALE: ———— 50 μ S/DIV.

FIGURE 11

RESPONSE OF VARIABLE BANDWIDTH FILTER IN 20KC BANDWIDTH
POSITION TO A PULSE NOT TUNED TO THE CENTER FREQUENCY
OF THE FILTER

This shows that the filter will not reject pulses as well as it will continuous frequencies.

When the frequency band of a pulse becomes greater than the filter bandwidth the pulse is attenuated, the output pulse length increased, and the filter selectivity reduced. Figure 12 shows the response of the 20 kc bandwidth position to various pulse lengths. As the input pulse length is reduced to less than 50 μ sec., the output pulse length is not proportionally reduced. Figure 13a shows the attenuation of the output for narrowing pulse lengths. For shorter pulse lengths less energy falls in the pass band of the filter. Figure 13b shows the increase in bandwidth for narrowing pulse lengths.

The bandwidth used to pass a pulse not only depends on the length of the pulse but also on the application. Wider bandwidths are required for a shorter rise time or delay time. Figure 14 shows the response of the filter to a 50 μ sec. pulse using three different bandwidths. The 20 kc bandwidth reception shown in Fig. 14a gives a rounded pulse with a minimum transmission of noise. The 140 kc bandwidth reception shown in Fig. 14c gives a square pulse but with more noise transmission. Figure 14b shows a 60 kc bandwidth reception.

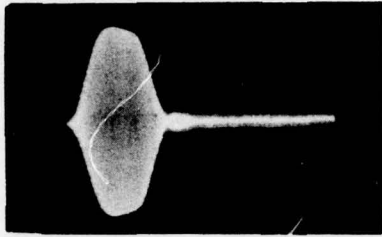

(a). 100μS PULSE

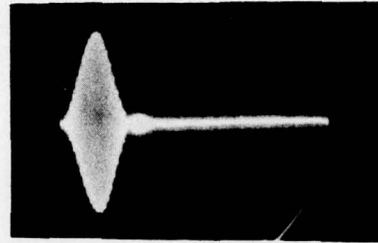

(b). 50μS PULSE

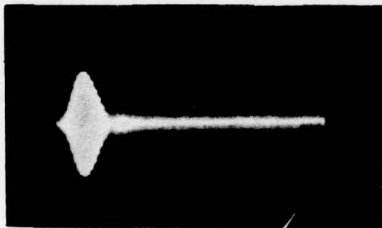

(c). 20μS PULSE

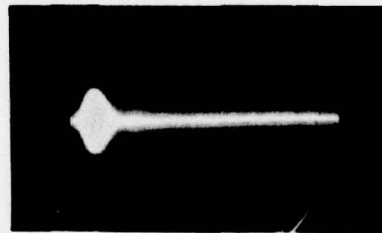

(d). 10μS PULSE

FIGURE 12
RESPONSE OF VARIABLE BANDWIDTH FILTER IN 20KC
BANDWIDTH POSITION TO VARIOUS PULSE LENGTHS

VERTICAL SCALE RELATIVE.

HORIZONTAL SCALE: ———— 50μS/DIV.

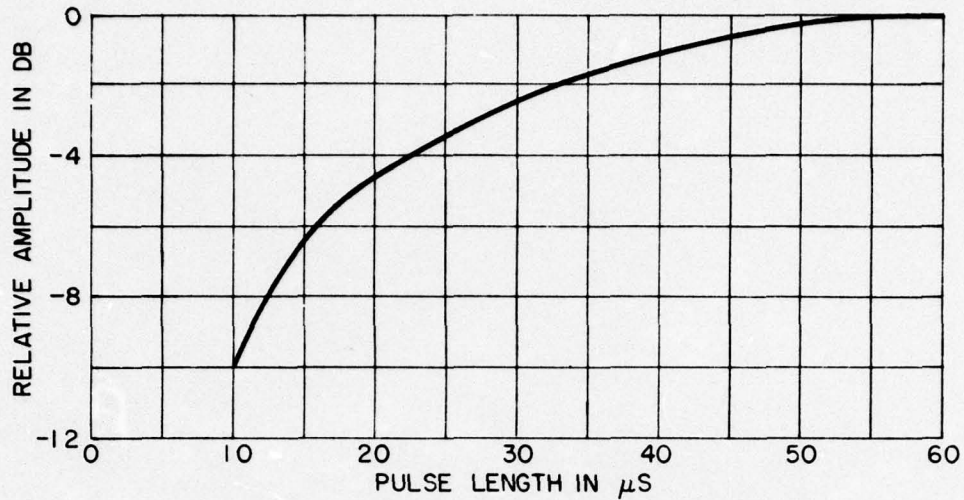

a. VARIATION IN OUTPUT PULSE AMPLITUDE WITH NARROWING PULSE LENGTH FOR POSITION I

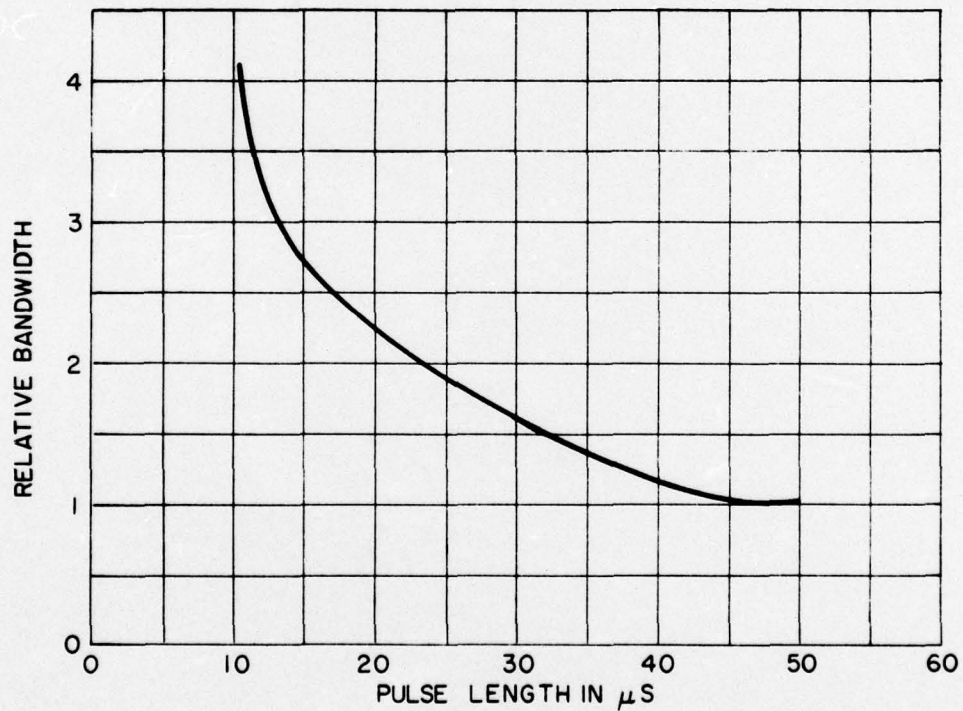

b. VARIATION IN BANDWIDTH WITH NARROWING PULSE LENGTH FOR POSITION I

FIGURE 13
EFFECT OF NARROWING THE PULSE LENGTH APPLIED TO VARIABLE BANDWIDTH FILTER WITH 20KC BANDWIDTH

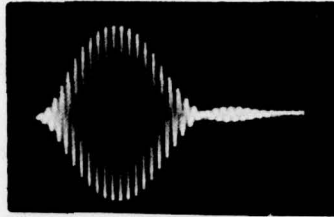

(a). 20KC BANDWIDTH

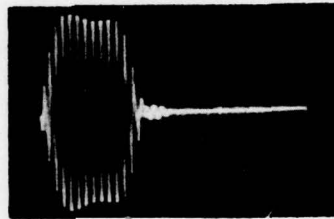

(b). 60KC BANDWIDTH

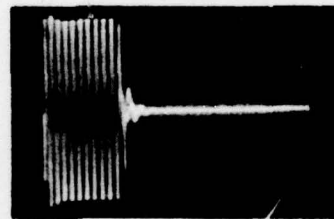

(c). 140KC BANDWIDTH

FIGURE 14
RESPONSE OF VARIABLE BANDWIDTH FILTER IN VARIOUS
BANDWIDTH POSITIONS TO A $50\mu\text{s}$ PULSE

VERTICAL SCALE RELATIVE.

HORIZONTAL SCALE : $\longleftrightarrow 20\mu\text{s}/\text{DIV.}$

CHAPTER VI

SUMMARY AND CONCLUSIONS

A unique design for a variable bandwidth filter for use with a superheterodyne pulse receiver has been developed. A model has been built, tested, and found to operate satisfactorily.

A bandwidth less than 20 kc is desirable for receiving continuous transmission signals. The minimum bandwidth of the filter is limited by the ratio of the shunt inductance to the series inductance. The inductance of the series inductor can be increased with the same self resonant frequency by winding a distributed inductor on several cores. The shunt inductance can be reduced if the output impedance of the low impedance cathode followere is reduced. This can be done by increasing the gain in the feedback loop of the amplifier. Care must be taken to prevent oscillation due to phase shift in the feedback loop. Rather than further reducing the bandwidth of the variable bandwidth filter, it is easier to build a separate synchronously tuned narrow band filter for use when continuous transmission reception is desired.

A variable bandwidth filter is particularly useful in the reception of pulses since the filter can be adjusted to give maximum rejection of undesired signals for the desired rise time of the output pulse. The rejection of a filter to detuned pulses is not as great as the rejection of continuous frequencies. Pulse lengths shorter than the reciprocal of the bandwidth produce attenuation and loss of selectivity in the filter.

APPENDIX

TRANSIENT RESPONSE OF A CONSTANT K FILTER

Since no relations were found in the literature for the transient response of a constant K filter, the following analysis was made. Considering a band pass filter as a low pass filter displaced in frequency, the transient response of an equivalent low pass filter will be determined.¹⁰ This analogy is not exact for a constant K filter, but is a good approximation. The circuit of a constant K low pass filter is shown in Fig. 15. R is the characteristic impedance, C the half section shunt capacity, and L the half section series inductance. The transfer function $G(s)$ is determined by solving the loop equations for the circuit.

$$G(s) = \frac{1}{2(1 + RCs) \left(1 + \frac{Ls}{R} + LCs^2\right)} \quad (26)$$

The transfer function is the same for either a " π " or " T " section. The following relations for a low pass filter are substituted into equation (26) to obtain (27).¹¹ ω_c is the 3 db cutoff frequency.

$$R = \sqrt{L/C} ; \quad \omega_c = \frac{1}{\sqrt{LC}}$$

$$G(s) = \frac{\omega_c^3}{2(s + \omega_c) (s^2 + \omega_c s + \omega_c^2)} \quad (27)$$

A partial fraction expansion of $G(s)$ allows the inverse Laplace transform to be taken.

¹⁰ G. E. Valley and H. Wallaman, Vacuum Tube Amplifiers (McGraw-Hill Book Company, Inc., New York, 1948), p. 274.

¹¹ Reference Data for Radio Engineers (International Telephone and Telegraph Corporation, New York, 1957), p. 166.

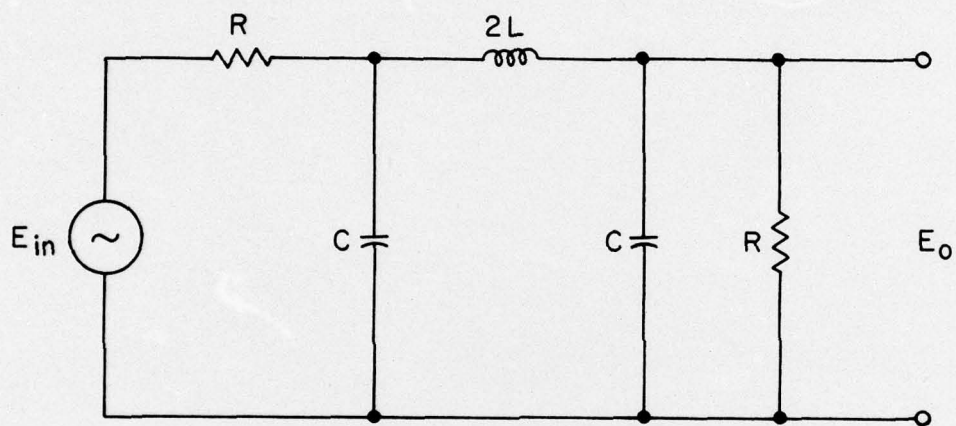

FIGURE 15
CONSTANT K LOW PASS FILTER CIRCUIT

$$G(t) = \frac{\omega_c}{2} \exp(-\omega_c t) - \frac{\omega_c}{2} \exp(-\frac{\omega_c}{2}t) \cos(\frac{\sqrt{3}}{2} \omega_c t) + \frac{\omega_c}{2\sqrt{3}} \exp(-\frac{\omega_c}{2}t) \sin(\frac{\sqrt{3}}{2} \omega_c t). \quad (28)$$

$G(t)$ is the frequency response of the low pass filter transferred into the time domain. A sketch of this function is shown in Fig. 16a. This can be obtained physically by applying a very short DC pulse to the input of the filter while observing the output as a function of time. Mathematically the DC pulse represents a unit impulse which has a Laplace transform of unity. A unit impulse applied to the input of a network will yield the frequency response since it does not change the transfer function.¹²

The filter response $R(t)$ to an input $F(t)$ can be obtained by taking a convolution integral between the input function and the time domain frequency response $G(t)$. $S_a(t)$ is the unit step function. For all (t) less than (a) , $S_a(t)$ is zero. For all (t) greater than (a) , $S_a(t)$ is unity. A pulse of length (a) can be represented by:

$$F(t) = 1 - S_a(t). \quad (29)$$

Applying the convolution integral:

$$R(t) = \int_0^t F(t - \tau) G(\tau) d\tau. \quad (30)$$

Substituting equations (28) and (29) into (30) and reducing:

¹² J. G. Truxal, Automatic Feedback Control System Synthesis (McGraw-Hill Book Company, Inc., New York, 1948), p. 55 ff.

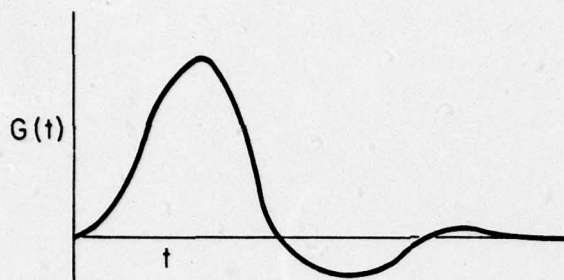

TIME DOMAIN FREQUENCY RESPONSE
OF CONSTANT K LOWPASS FILTER
(a.)

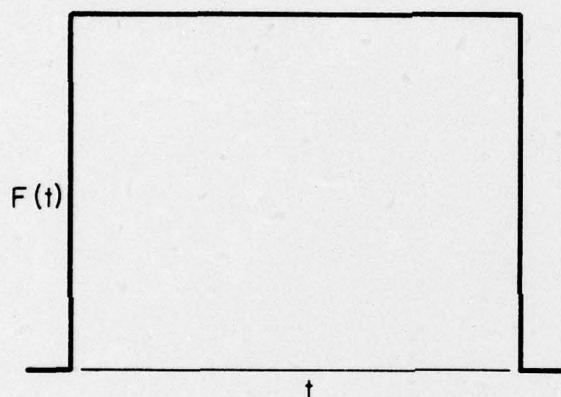

INPUT PULSE TO LOWPASS FILTER
(b.)

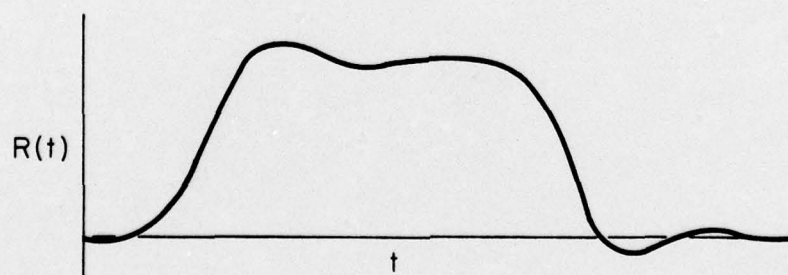

RESPONSE OF CONSTANT K LOWPASS TO A PULSE
(c.)

FIGURE 16

FUNCTIONS INVOLVED IN CONVOLUTION INTEGRAL
TO OBTAIN THE RESPONSE OF A CONSTANT K
LOWPASS FILTER TO A PULSE

$$\begin{aligned}
 R(t) = & \frac{1}{2} - \frac{1}{2} \exp(-\omega_c t) - \frac{1}{\sqrt{3}} \exp\left(-\frac{\omega_c}{2} t\right) \sin\left(\frac{\sqrt{3}}{2} \omega_c t\right) - \\
 & - S_a(t) \left[\frac{1}{2} - \frac{1}{2} \exp[-\omega_c (t - a)] - \frac{1}{\sqrt{3}} \exp\left[-\frac{\omega_c}{2} (t-a)\right] \sin\left[\frac{\sqrt{3}}{2} \omega_c (t-a)\right] \right].
 \end{aligned}
 \tag{31}$$

A sketch of the low pass filter response to a pulse long enough to allow the transient to settle is shown in Fig. 16c. This is the transient response of the filter since a unit step function has been applied at (t) equal to zero, and a negative step function applied at (t) equal (a). The first three terms of R(t) are the transient response of a constant K low pass filter. The rise time, delay time, settling time, and the overshoot of the filter can be determined from these terms.¹³ Since this equation is transcendental it is not feasible to get an analytical solution; thus a graphical approach is taken. Figure 17 is a plot of the transient response of the filter. The above factors are read from the curve. The 10 percent to 90 percent rise time is $2.25/\omega_c$; the delay time for 50 percent rise is $2.15/\omega_c$; the settling time to 2 percent is $6.7/\omega_c$; the overshoot is 8 percent. Since a low pass filter has an effective bandwidth of $2\omega_c$, the above values must be divided by π for a band pass filter with its bandwidth in cps. This gives a rise time of $0.715/\Delta f$, a delay times of $0.85/\Delta f$, and a settling time of $2.13/\Delta f$. The overshoot is the same.

¹³ Truxal, op. cit. p. 79.

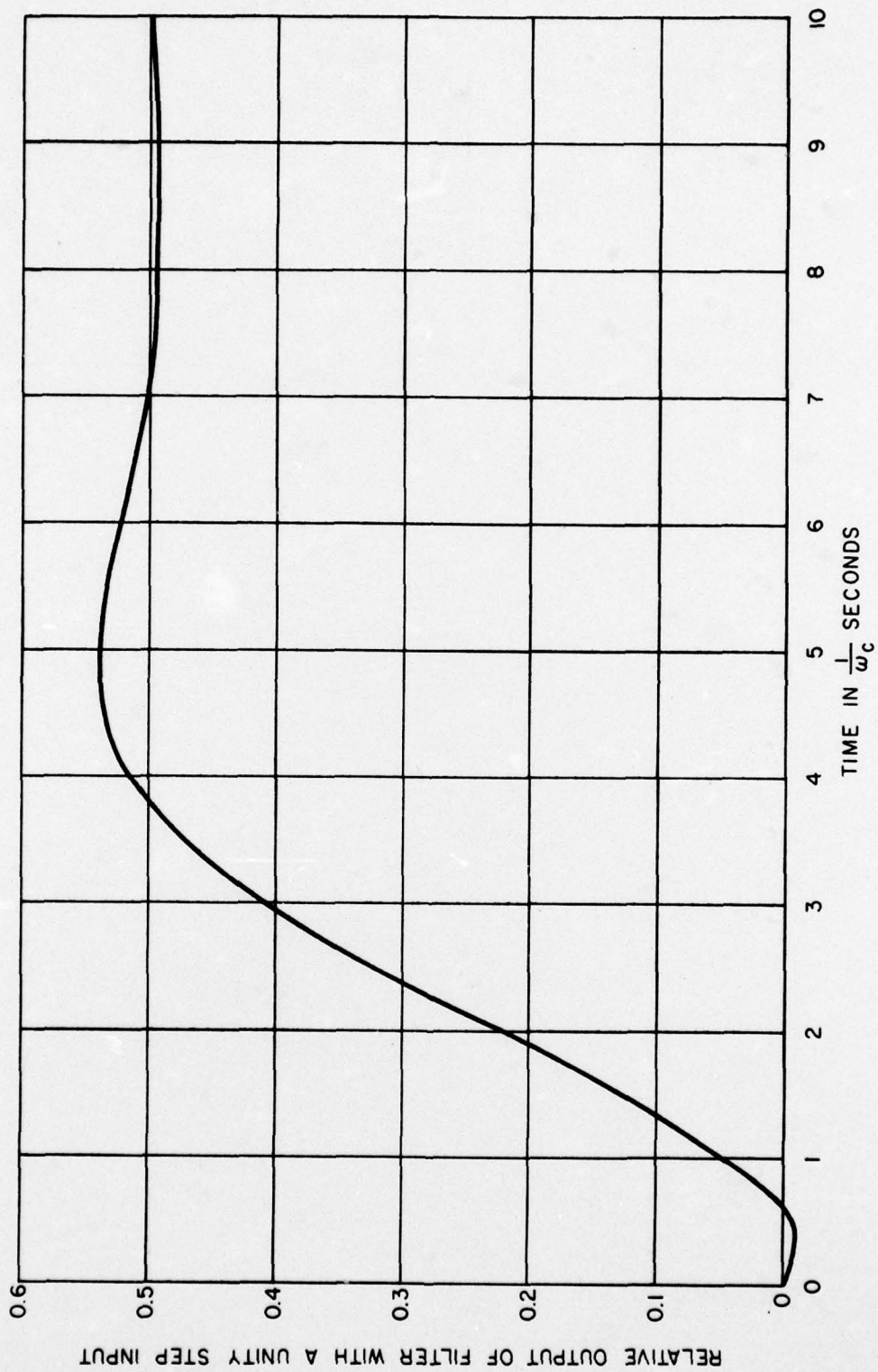

FIGURE 17
TRANSIENT RESPONSE OF A CONSTANT K LOW PASS FILTER

These factors give information about the output pulse shape, but do not indicate the minimum pulse length which the filter will pass without attenuation. The output pulse can be determined by considering the input a positive and a negative step function. The output pulse is the difference between the transient response and the transient response displaced in time by the input pulse length. The minimum pulse length with no attenuation for a low pass filter is $3.1/\omega_c$. This is approximately $1/\Delta f$ for a band pass filter.

BIBLIOGRAPHY

1. Chestnut, H. and Mayer, R. W. Servomechanisms and Regulating System Design, John Wiley and Sons, Inc., New York, 1951.
2. Churchill, R. V. Modern Operational Mathematics in Engineering, McGraw-Hill Book Company, Inc., New York, 1944.
3. Electronic Tubes, General Electric Company, Schenectady, New York, 1950.
4. Everitt, W. L. and Anner, G. E. Communications Engineering, McGraw-Hill Book Company, Inc., New York, 1956.
5. Hammack, C. M. "Cathode Follower of Very Low Output Resistance," Electronics, Vol. 19, No. 11, November, 1946, p. 206.
6. Holbrook, J. G. Laplace Transforms for Electrical Engineers, Pergamon Press, New York, 1959.
7. Landee, R. W., Davis, D. C., and Albrecht, A. P. Electronic Designers Handbook, McGraw-Hill Book Company, Inc., New York, 1957.
8. LePage, W. R. and Seely, S. General Network Analysis, McGraw-Hill Book Company, Inc., 1952.
9. Markus, J. and Zeluff, V. Electronics for Communications Engineers, McGraw-Hill Book Company, Inc., New York, 1952, p. 8.
10. Martin, T. L. Electronic Circuits, Prentice-Hall, Inc., New York, 1956.
11. Reference Data for Radio Engineers, International Telephone and Telegraph Corporation, New York, 1957.
12. Reich, H. J. "The Use of Vacuum Tubes as Variable Impedance Elements," Proceedings of The Institute of Radio Engineers, Vol. 30, June, 1942, p. 288.
13. Terman, F. E. Electronic and Radio Engineering, McGraw-Hill Book Company, Inc., New York, 1955.
14. Truxal, J. G. Automatic Feedback Control System Synthesis, McGraw-Hill Book Company, Inc., New York, 1955.
15. Valley, G. E. Jr. and Wallaman, H. Vacuum Tube Amplifiers, McGraw-Hill Book Company, Inc., New York, 1948.

DISTRIBUTION LIST

Copy

1. Chief, Bureau of Ships, Code 689A
2. Chief, Bureau of Ships, Code 689B
- 3-4-5. Chief, Bureau of Ships, Code 689B
6. Chief, Bureau of Ships, Code 631
7. Chief of Naval Operations, OpNav 922G
- 8-9. Chief, Bureau of Naval Weapons, Code AV 43
10. Office of Naval Research, Code 411
- 11-12. Office of Naval Research, Code 463
13. Commander, Submarine Development Group TWO
14. Commander, Submarine Force Pacific Fleet
15. Commanding Officer and Director, U. S. Navy Electronics Laboratory
- 16-17. Commanding Officer and Director, U. S. Navy Underwater Sound Lab.
- 18-19. Commanding Officer, Naval Air Development Center, Johnsville, Pa.
Attn: NADC Library
20. Director, U. S. Naval Research Laboratory
21. Director, U. S. Naval Research Laboratory, Code 5530
22. Director, U. S. Naval Research Laboratory, Code 1045
23. Director, U. S. Naval Research Laboratory, Code 2021
24. Commander, U. S. Naval Ordnance Laboratory
- 25-26. British Joint Services Mission (Navy Staff)
27. Canadian Joint Staff
28. Director, Marine Physical Laboratory
29. Research Analysis Group, Brown University
30. Columbia University, Lamont Geological Observatory
31. Director, Woods Hole Oceanographic Institution
32. Applied Physics Laboratory, The Johns Hopkins University
33. Commanding Officer, U. S. Navy Mine Defense Laboratory
34. C. O. and Dir., U. S. Navy Electronics Laboratory
Attn: Arthur Roshon
35. C. O. and Dir., U. S. Navy Electronics Laboratory
Attn: Dr. G. H. Curl, Code 2230
36. Sangamo Electric Company, Attn: C. H. Lanphier
37. Division of Oceanography, Hydrographic Office, Washington 25, D. C.
38. General Electric Company, Syracuse, N. Y.
39. Committee on Undersea Warfare, National Research Council
40. Ordnance Research Laboratory, The Pennsylvania State University
41. C. O., U. S. Navy Mine Defense Laboratory, Attn: Dr. J. Hagemann
42. C. O., U. S. Navy Defense Laboratory, Attn: Mr. R. J. Urick
43. Laboratory of Marine Physics, Yale University
44. U. S. Naval Ordnance Test Station, Pasadena, California
Attn: Pasadena Annex Library
45. Commander, Mine Force, U. S. Atlantic Fleet, U. S. Naval Minecraft Base,
Charleston, South Carolina

DISTRIBUTION LIST

Copy

46. Commander, Key West Test and Evaluation Detachment, Key West, Florida
47. U. S. Navy Postgraduate School, Monterey, California
48. VITRO Corporation of America, Silver Spring Laboratory
49. Edo Corporation, Attn: Dr. W. R. Ryan
50. Applied Physics Laboratory, University of Washington, Seattle, Wash.
51. Commander, Mine Force, U. S. Pacific Fleet, U. S. Naval Station, Long Beach, California
52. Commander, Harbor Defense Unit, Norfolk, Virginia
53. Department of the Navy, Office of the Chief of Naval Operations (Op-315E), Washington 25, D. C.
54. Director, Engineer Research and Development Laboratories, Fort Belvoir, Virginia, Attn: Mine Detection Branch, Mr. Chandler Stewart
55. Operations Evaluation Group, Navy Department, Op03EG Washington 25, D. C., Attn: Dr. L. E. Channel
56. Stanford Research Institute, Menlo Park, California
Attn: Dr. Vincent Salmon
57. Director, U. S. N. Underwater Sound Reference Laboratory
P. O. Box 8337, Orlando, Florida
58. ONR, Special Representative, The University of Texas
59. Director, DRL
60. L. A. Jeffress
61. C. M. McKinney
62. H. V. Hillery
63. L. D. Hampton
64. R. H. Wallace
- 65-66. Library, DRL