

ADA 035039

10

B-5

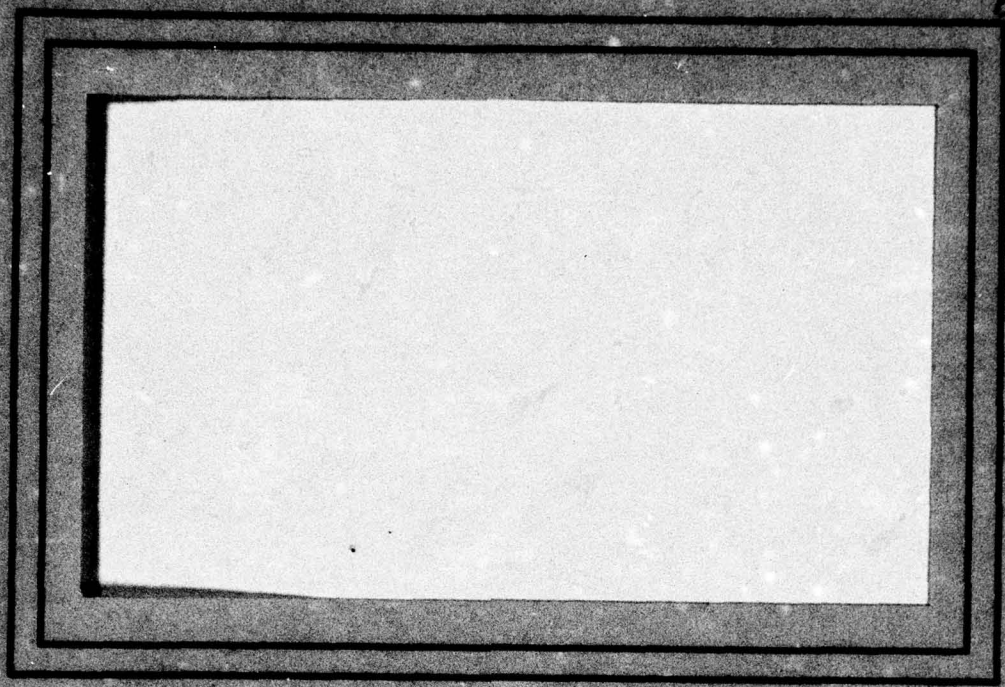

COMPUTER SCIENCE
TECHNICAL REPORT SERIES



DISTRIBUTION STATEMENT A
Approved for public release;
Distribution Unlimited

UNIVERSITY OF MARYLAND
COLLEGE PARK, MARYLAND
20742

DDC
RECEIVED
JAN 21 1977
RESERVE
A

COPY AVAILABLE TO DDC DOES NOT
PERMIT FULLY LEGIBLE PRODUCTION

**ALGORITHMS AND HARDWARE TECHNOLOGY
FOR IMAGE RECOGNITION**

Quarterly Report
1 May-31 July, 1976

Contract DAAG53-76C-0138
(DARPA Order 3206)

Computer Science Center
University of Maryland
College Park, MD 20742

ABSTRACT

Techniques for detecting tactical targets on Forward-Looking Infrared (FLIR) imagery are being investigated. The principal topics covered include target and background models, object extraction and classification, and hardware technology applicable to real-time implementation.

DISTRIBUTION STATEMENT A
Approved for public release;
Distribution Unlimited

D D C
RECEIVED
JAN 31 1977
A

TABLE OF CONTENTS

Volume I: Maryland Report

1. Introduction
2. Project review
 - A1. Data base acquisition and preprocessing
 - A2. Image processing software
 - B. Models for FLIR image understanding
 - B1. The noise-free case in one dimension
 - B2. Extension to two dimensions
 - B3. The effect of noise
 - C. Automatic object detection
 - D. Automatic threshold selection
 - E1. Edge reinforcement prior to noise cleaning
 - E2. Noise cleaning by averaging
 - E3. Noise region filtering by simultaneous local operations
 - E4. Connected component analysis and feature extraction
 - F. Discrimination and classification
3. Plans for the next quarter
 - A. Data sets
 - B. Models
 - C. Windows
 - D. Algorithms
 - E. Classifiers
 - F. Target identification

References

Volume II: Westinghouse Report

A Discussion of Design Goals and Hardware Implementation
for an Automatic Target Cueing System

| | |
|--------------------------------|--|
| RECEIVED BY | |
| DTIC | WFO/DTIC <input checked="" type="checkbox"/> |
| DDC | DDC/DTIC <input type="checkbox"/> |
| ANNOUNCED | <input type="checkbox"/> |
| JUSTIFICATION | |
| BY | |
| DISTRIBUTION/AVAILABILITY CODE | |
| DATE | |
| A | |

LIST OF FIGURES

| <u>Figure</u> | <u>Title</u> | <u>Section</u> |
|---------------|---|----------------|
| 1a. | 256-level histogram | 2.A1 |
| b. | Same histogram requantized to 64 levels | 2.A1 |
| 2 | Picture processing hardware configuration | 2.A2 |
| 3 | A picture processing algorithm skeleton for neighborhood operations | 2.A2 |
| 4 | Spatial gray level variation of a one-dimensional image | 2.B1 |
| 5 | Joint (gray level, edge value) histogram corresponding to Fig. 4 | 2.B1 |
| 6 | Three-class discriminant functions | 2.B1 |
| 7 | Two-class discriminant function | 2.B1 |
| 8 | Spatial gray level variation of a two-dimensional image | 2.B2 |
| 9 | Joint (gray level, edge value) histogram corresponding to Fig. 8 | 2.B2 |
| 10 | Component densities corresponding to Fig. 9 | 2.B3 |
| 11 | Rayleigh distributions | 2.B3 |
| 12 | Probability surfaces in the noisy case | 2.B3 |
| 13 | Discriminant construction by valley seeking | 2.B3 |
| 14 | Vertical straight line discriminant | 2.B3 |
| 15 | Oblique straight line discriminants | 2.B3 |
| 16 | Discriminant based on valley detection | 2.B3 |
| 17 | Discriminant based on error probability adjustment | 2.B3 |
| 18 | The SPAN technique applied to cell and chromosome pictures | 2.C |
| 19 | The SPAN technique applied to two FLIR windows | 2.C |

LIST OF FIGURES (continued)

| <u>Figure</u> | <u>Title</u> | <u>Section</u> |
|---------------|--|----------------|
| 20 | 156 FLIR windows and their histograms | 2.D |
| a. | 42 Tank windows | |
| b. | 26 Truck windows | |
| c. | 28 APC windows | |
| d. | 60 noise windows | |
| 21 | Edge values and above-threshold edge values for a set of windows | 2.D |
| 22 | Thresholded images, using the mean gray level of the points in the 80th gray level percentile as a threshold | 2.D |
| 23 | Two-dimensional (gray level, gradient) histograms | 2.E1 |
| 24 | Thresholding using combined (gray level, gradient) thresholds | 2.E1 |
| 25 | Sampling vs. averaging in target windows | 2.E2 |
| 26 | Effects of iterating SHRINK/EXPANDs | 2.E3 |
| 27 | SHRINK/EXPAND: comparison of edge detection operators | 2.E3 |
| 28 | Leniency in SHRINK/EXPAND definitions for windows thresholded by two methods | 2.E3 |
| 29 | SHRINK/EXPAND of thresholded images based on four edge operators | 2.E3 |
| 30 | Components labelled with distinct solid gray levels | 2.E4 |

LIST OF TABLES

| <u>Table</u> | <u>Title</u> | <u>Section</u> |
|--------------|--|----------------|
| 1 | NVL data ground truth | 2.A1 |
| 2a. | Feature values based on gray level | 2.C |
| b. | Feature values based on 8x8 differences | 2.C |
| c. | Fisher linear discriminant classification results using Table 2a features | 2.C |
| d. | Fisher linear discriminant classification results using Table 2b features | 2.C |
| 3 | Gray level statistics for points of high edge value | 2.D |
| 4a. | Fisher linear discriminant results on 30 targets and 59 noise regions using features 1-13 | 2.F |
| b. | Fisher linear discriminant results on 30 targets and 59 noise regions using features 1, 5-8, 10-13 | 2.F |
| c. | Fisher linear discriminant results on 30 targets and 114 noise regions using features 1-13 | 2.F |

1. Introduction

This document reports on the progress of the University of Maryland/Westinghouse Corporation project entitled "Algorithms and Hardware Technology for Image Recognition" during the initial period May 1-July 31, 1976. The project has two principal goals:

- a) Selection of state-of-the-art algorithms for automatic target cueing, and implementation of one or two selected algorithms in hardware to demonstrate the feasibility of incorporating such algorithms in a reconnaissance sensor.
- b) Exploration of new approaches to image understanding, with emphasis on techniques applicable to target cueing and similar applications, as well as on image modeling for performance prediction.

The project consists of three phases all of which involve collaboration between the University and its subcontractor, the Systems Development Division of Westinghouse. The three phases and their breakdown into tasks are displayed in the following table:

| <u>Phase</u> | <u>Task</u> |
|--------------|---|
| I | (Task and technology review) |
| | 1) Data base acquisition |
| | Obtain data bases consisting of real-world imagery containing representative target-background combinations for selected reconnaissance sensors and conditions. |
| | 2) Review of tri-service operational needs and resulting system design constraints. |
| | Meet with tri-service representatives to dis- |

Phase Task

cuss operational target detection problems. Emphasis will probably be placed on night vision and tactical IR sensors. Choice of sensors and operational environments will define constraints on hardware design.

3) Hardware/algorithm interface

Hardware constraints will restrict choice of algorithms for implementation; algorithm design will define requirements on hardware performance. This interaction will constitute a continuing aspect of the Maryland/Westinghouse collaboration.

II (Algorithm development and testing)

4) Algorithm development

Exploration of new approaches; evaluation of standard approaches, modified as appropriate for the given input data.

5) Algorithm selection and test

Algorithm implementation, feasibility testing, performance evaluation on selected data bases, comparison with current target cueing systems performance.

6) Target and background modelling

Development of statistical models; estimation of model parameters for given data bases; use of models to predict target detection performance.

III (Hardware design, fabrication, and testing)

In the first quarter, major efforts have been devoted to a cross-sectional study of the algorithmic steps comprising a solution to the cueing problem. The purpose has been to investigate the inherent complexity of Forward-Looking Infrared (FLIR) imagery and to identify the areas in which significant contributions to the state of the art are likely to be made.

The current research effort in automatic target cueing consists of seven project areas:

- . Data base acquisition and preprocessing
- . Models for FLIR image understanding
- . Automatic object detection
- . Automatic threshold selection
- . Noise region elimination and component feature extraction
- . Component classification and target recognition
- . Hardware technology for algorithm implementation

In each project area, one or more approaches have been studied as described in the following sections of this report. The Westinghouse review of hardware technology is appended to this report as a separate volume.

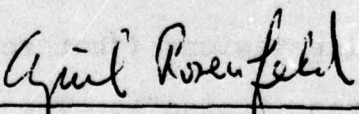

Azriel Rosenfeld
Research Professor
(Principal Investigator)

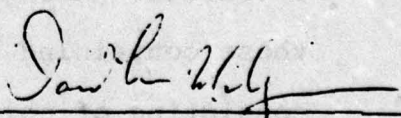

David L. Milgram
Assistant Professor
(Co-Principal Investigator)

2. Project Review

A1. Data Base Acquisition and Preprocessing

The image data base which has been investigated in this report consists of low altitude infrared scenes of tanks, trucks and APC's against a sparsely wooded or barren background. The images were digitized by the U.S. Army Night Vision Laboratory (NVL) from video tapes of the FLIR signal which drives the cockpit display. Westinghouse reformatted the data and supplied duplicate digital tapes. Aside from a variety of noise effects, the image display fiducial marks and numeric situation data. A number of scenes were imaged in complement (negative) format.

In all, 13 tapes containing 90 scenes were received. Each scene image was present as a tape file of 800 records (lines) of 1024 bytes (pixels) each. The pixels had been quantized to 16 bits. According to the ground truth supplied, the scenes contained views of targets in various aspects and at various ranges. The available ground truth is presented in Table 1.

Using the ground truth, a set of 128x128 pixel windows containing the identified targets were examined. In addition, a number of windows containing no targets were extracted. Among the latter, a distinction was made between those containing object-like regions ("hot rocks") and those consisting of noise patterns ("noise"). The windows were further reduced by sampling to 64x64 image points. The extracted windows were requantized to 64 gray levels by dropping the low order two bits. As may be seen from the typical

| <u>Image</u> <u>Ref.No.</u> | <u>Tape</u> | <u>Frame</u> | <u>Contents</u> | | | <u>Image</u> <u>Ref.No.</u> | <u>Tape</u> | <u>Frame</u> | <u>Contents</u> | | |
|--------------------------------|-------------|--------------|-----------------|-----|-----|--------------------------------|-------------|--------------|-----------------|-----|---|
| 1 | A | 1 | T/S | | | 46 | E | 6 | A/E | T/D | |
| 2 | A | 2 | T/S | | | 47 | E | 7 | R/E | | |
| 3 | A | 3 | T/S | R/S | | 48 | E | 8 | A/E | R/D | |
| 4 | A | 4 | T/S | R/S | | 49 | E | 9 | * | | |
| 5 | A | 5 | * | | | 50 | E | 10 | T | A | |
| 6 | A | 6 | T/S | R/S | | 51 | F | 1 | A | T/S | R |
| 7 | A | 7 | * | | | 52 | F | 2 | A | T/S | R |
| 8 | A | 8 | T/S | | | 53 | F | 3 | A | T/S | R |
| 9 | A | 9 | T/S | R/S | | 54 | F | 4 | A | T/S | R |
| 10 | A | 10 | T/S | | | 55 | F | 5 | A | T/S | R |
| 11 | B | 1 | T/S | | | 56 | F | 6 | R | T | A |
| 12 | B | 2 | T/S | | | 57 | F | 7 | R | T | A |
| 13 | B | 3 | T/S | | | 58 | F | 8 | R | T | A |
| 14 | B | 4 | T/S | | | 59 | F | 9 | R | T | A |
| 15 | B | 5 | T/S | | | 60 | F | 10 | A/E | | |
| 16 | B | 6 | T/S | | | 61 | GH | 1 | A/E | T/D | |
| 17 | B | 7 | T/S | | | 62 | GH | 2 | T/S | | |
| 18 | B | 8 | R/E | | | 63 | GH | 3 | T/S | | |
| 19 | B | 9 | * | | | 64 | GH | 4 | T/S | | |
| 20 | B | 10 | * | | | 65 | GH | 5 | ? | T | |
| 21 | C | 1 | A/S | T/E | | 66 | GH | 6 | ? | T | ? |
| 22 | C | 2 | A/S | T/E | R/E | 67 | GH | 7 | ? | ? | ? |
| 23 | C | 3 | A/S | T/E | R/E | 68 | GH | 8 | ? | T | |
| 24 | C | 4 | A/S | T/E | R/E | 69 | GH | 9 | ? | T | |
| 25 | C | 5 | * | | | 70 | GH | 10 | * | | |
| 26 | C | 6 | R/E | T/S | | 71 | GH | 11 | R/D | | |
| 27 | C | 7 | R | | | 72 | GH | 12 | R/D | | |
| 28 | C | 8 | R | T/S | | 73 | GH | 13 | A/E | T/D | |
| 29 | C | 9 | T/S | A | | 74 | GH | 14 | A/E | T/D | |
| 30 | C | 10 | T/S | A | | 75 | GH | 15 | A/E | T/D | |
| 31 | D | 1 | R | T/S | | 76 | HI | 1 | A/E | T/D | |
| 32 | D | 2 | R | T | A | 77 | HI | 2 | R/D | | |
| 33 | D | 3 | R | T | A | 78 | HI | 3 | A/E | T/D | |
| 34 | D | 4 | R | T | A | 79 | HI | 4 | A/E | T/D | |
| 35 | D | 5 | R | T | A | 80 | HI | 5 | A/E | T/D | |
| 36 | D | 6 | * | | | 81 | HI | 6 | ? | T | |
| 37 | D | 7 | A/E | | | 82 | HI | 7 | ? | T | |
| 38 | D | 8 | A/E | T/S | | 83 | HI | 8 | A/E | | |
| 39 | D | 9 | * | | | 84 | HI | 9 | A/E | | |
| 40 | D | 10 | T | | | 85 | HI | 10 | A/E | | |
| 41 | E | 1 | R/E | | | 86 | HI | 11 | A/E | | |
| 42 | E | 2 | A/E | T/D | | 87 | HI | 12 | A/E | | |
| 43 | E | 3 | T/D | | | 88 | HI | 13 | A/E | T/D | |
| 44 | E | 4 | A/E | | | 89 | HI | 14 | T/D | | |
| 45 | E | 5 | A/E | T/D | | 90 | HI | 15 | A/E | | |

T = tank /S = side view
 R = truck /E = end view
 A = apc /D = 3/4 view
 * = no target

Table 1. NVL Data Ground Truth.

| <u>Image</u> <u>Ref.No.</u> | <u>Tape</u> | <u>Frame</u> | <u>Contents</u> |
|--------------------------------|-------------|--------------|-----------------|
| 91 | JK | 1 | A/E |
| 92 | JK | 2 | T/D |
| 93 | JK | 3 | A/E |
| 94 | JK | 4 | A/E |
| 95 | JK | 5 | T/D |
| 96 | JK | 6 | A/E |
| 97 | JK | 7 | A/E |
| 98 | JK | 8 | A/E |
| 99 | JK | 9 | T/D |
| 100 | JK | 10 | R/E |
| 101 | JK | 11 | A/E |
| 102 | JK | 12 | A/E |
| 103 | JK | 13 | A |
| 104 | JK | 14 | R |
| 105 | JK | 15 | T/D |
| 106 | L | 1 | A/E |
| 107 | L | 2 | A/E |
| 108 | L | 3 | A/E |
| 109 | L | 4 | T |
| 110 | L | 5 | T/D |
| 111 | L | 6 | A/E |
| 112 | L | 7 | A/E |
| 113 | L | 8 | A/E |
| 114 | L | 9 | T/D |
| 115 | L | 10 | A/E |
| 116 | MN | 1 | A |
| 117 | MN | 2 | A |
| 118 | MN | 3 | A |
| 119 | MN | 4 | A |
| 120 | MN | 5 | A |
| 121 | MN | 6 | A |
| 122 | MN | 7 | T |
| 123 | MN | 8 | T |
| 124 | MN | 9 | T |
| 125 | MN | 10 | T |
| 126 | MN | 11 | T |
| 127 | MN | 12 | T |
| 128 | MN | 13 | T |
| 129 | MN | 14 | T |
| 130 | MN | 15 | T |
| 131 | NO | 1 | R |
| 132 | NO | 2 | T/E |
| 133 | NO | 3 | R |
| 134 | NO | 4 | R |
| 135 | NO | 5 | T/E |
| 136 | NO | 6 | T/E |
| 137 | NO | 7 | R |
| 138 | NO | 8 | R |
| 139 | NO | 9 | R |
| 140 | NO | 10 | R |
| 141 | NO | 11 | R |
| 142 | NO | 12 | R |
| 143 | NO | 13 | T |
| 144 | NO | 14 | R |
| 145 | NO | 15 | T |

Table 1 (continued)

histograms shown in Figure 1, the original images exhibit non-uniformity of quantization, and the information loss due to requantization should be small. A final preprocessing step complemented those windows which contained targets in complement form.

An assessment of the data base reveals a wide range of target sizes and levels of thermal emission. To the naked eye, some of the small indistinct targets, while detectable, appear virtually unclassifiable. The larger targets do exhibit characteristic shapes, though. We have assumed at this stage that it is more important to detect targets at long range than to classify them once their shapes are discernible at closer range. However, shape recognition for target classification will be studied extensively in the near future.

The variability of the images and the large amount of noise present indicate the need for the acquisition of further data bases to substantiate or challenge the assumptions made in the present study.

A2. Image Processing Software

Software development has progressed in the implementation of MINIXAP, a research-oriented picture processing system designed for the PDP 11/45 computer. Its current capabilities have enabled it to assume some of the computing tasks in processing the NVL imagery data bases.

Figure 2 shows the basic hardware configuration of the system. Picture files are stored locally on disk,

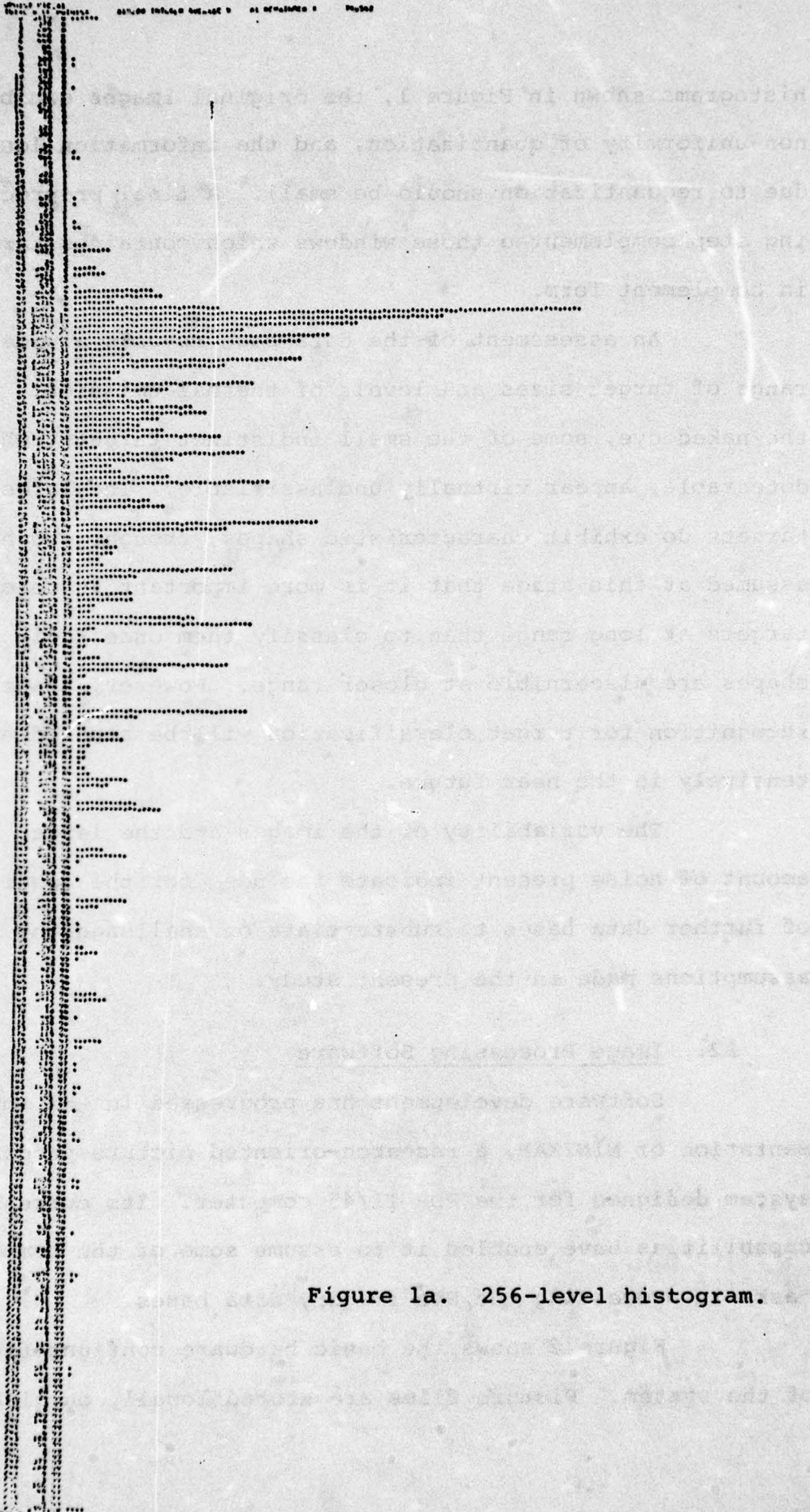

Figure 1a. 256-level histogram.

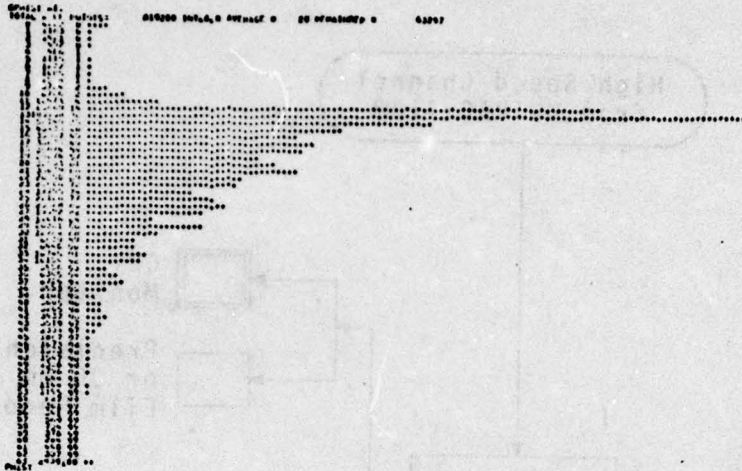

Figure 1b. Same histogram re-quantized to 64 levels.

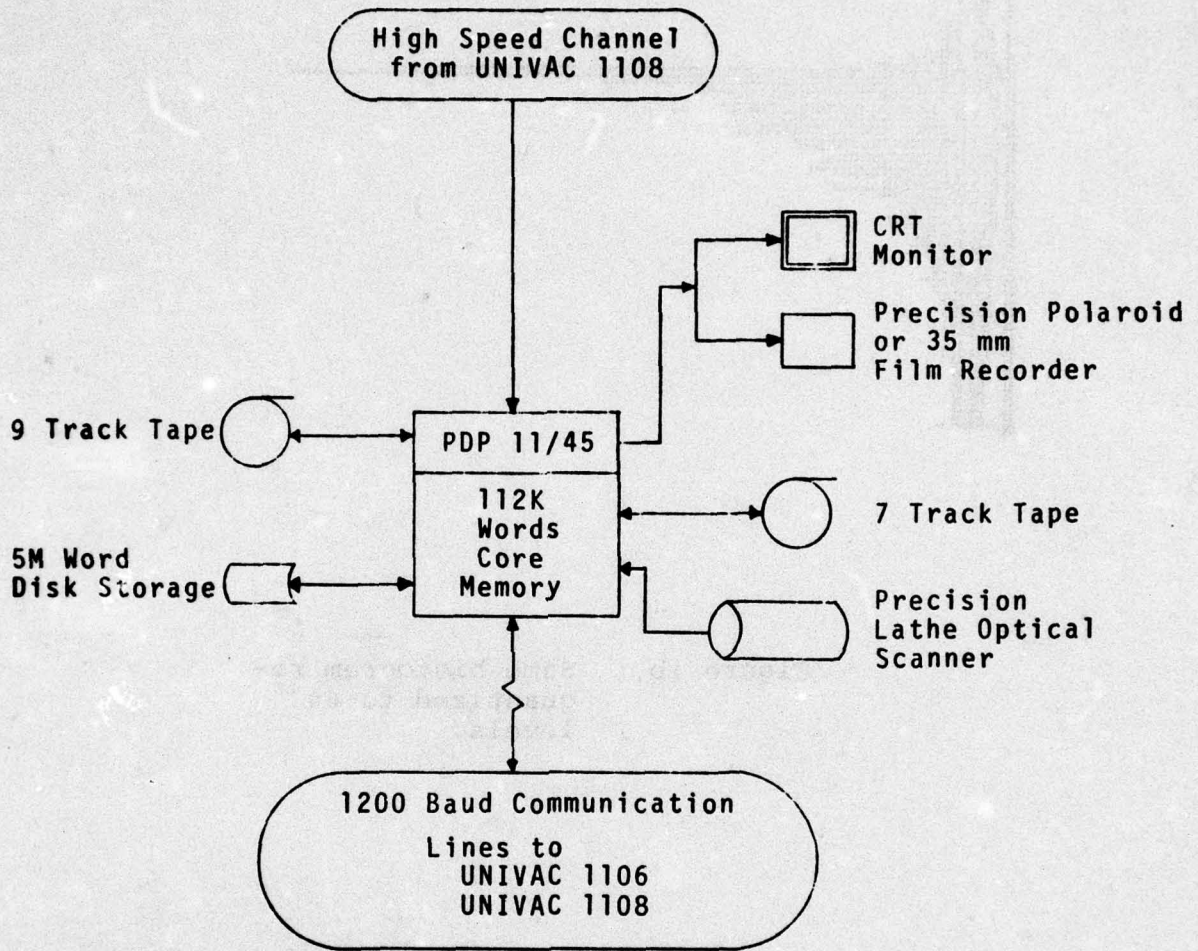

Figure 2: Picture Processing Hardware Configuration

9-track or 7-track tape. Picture data can be transferred to the PDP 11/45 from the mass storage facilities of a UNIVAC 1108 computer via a high-speed UNIVAC 1108 channel. Images may be input from a precision drum-type optical scanner, and output to either a CRT monitor or a precision Polaroid or 35mm film recorder. Medium speed communication lines to UNIVAC 1106 and UNIVAC 1108 computers provide additional paths for picture data transfer and for program development activities.

MINIXAP has been designed in a four-level hierarchy. The bottom level, written in PDP 11 assembly language, manages a data base of picture files and provides device-independent I/O of picture intensity data. The second level provides a convenient command interface to the bottom level from the programming language LISP. The third level, written in LISP, is a collection of picture processing algorithm skeletons. An algorithm skeleton is a program-like structure in which certain arguments and functions are left unspecified until the skeleton is prepared for execution. At that time, the appropriate arguments and functions are associated with the skeleton, and the completed program may be executed. Many common image operations are sufficiently similar that they may be regarded as instantiations of algorithm skeletons. Figure 3 illustrates an algorithm skeleton for a picture processing operation which uses one input picture, generates one output picture, and in which the transformation function is a neighborhood operator. The Roberts gradient operator is an example of a neighbor-

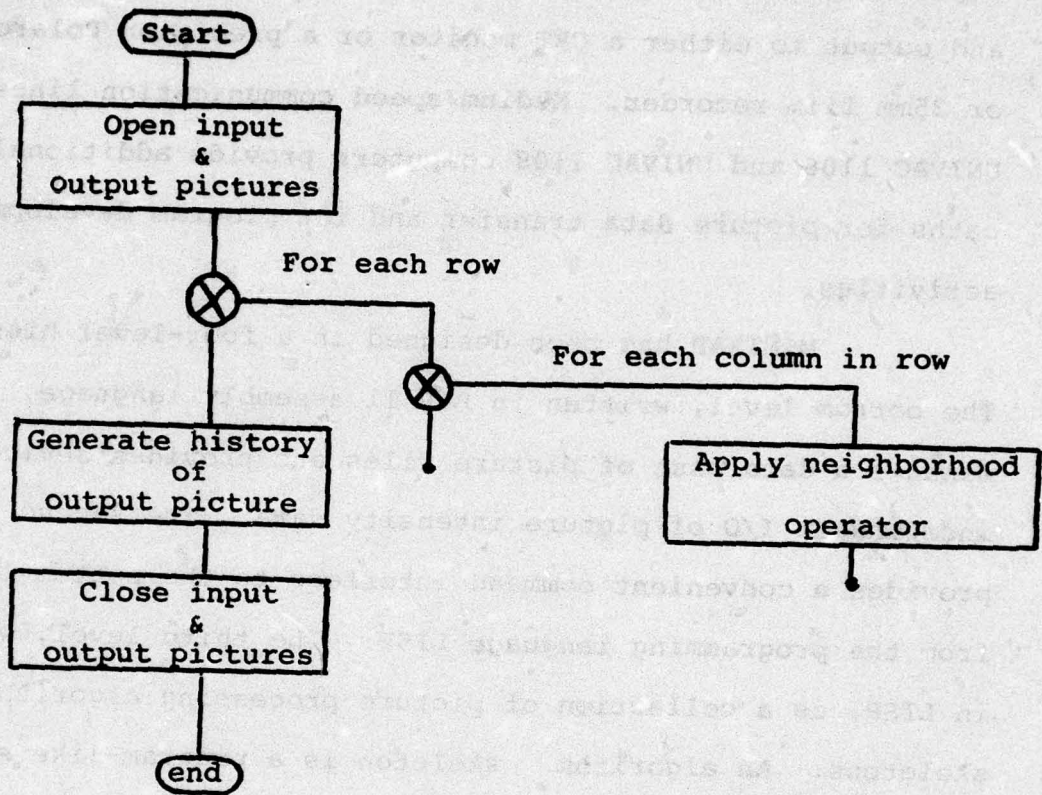

Figure 3.

A Picture Processing Algorithm Skeleton for Neighborhood Operations.

hood operator using a 2x2 neighborhood size. The fourth level in the MINIXAP hierarchy is a collection of application packages, which use the algorithm skeletons to perform picture processing operations.

Because of the interactive nature of the user interface language LISP, the generality of the data structures afforded by LISP, and the collection of algorithm skeletons provided, MINIXAP should be a useful tool for use in picture processing algorithm development.

The following utility routines and application packages are currently available in MINIXAP:

- (1) Utilities for:
 - (a) picture printing
 - (b) histogram generation and printing
 - (c) picture copying
 - (d) filename manipulation to facilitate the handling of large data bases
- (2) Application packages
 - (a) a cooccurrence matrix generator
 - (b) an edge detection package, containing the Roberts gradient, Laplacian, "3 by 3" gradient, and "DIFF" operators
 - (c) a propagation package, containing shrink/expand routines, thinning operators, distance transform and skeletonization operators, and border-following routines
 - (d) a picture compression package for block averaging

Thus far, MINIXAP has been used in the object windowing, automatic threshold determination and noise cleaning phases of processing of FLIR imagery. It is anticipated that much of the future image processing algorithm development and testing for FLIR imagery will be done using MINIXAP.

B. Models for FLIR Image Understanding

The purpose of an image model is to define and account for significant variables of an image processing problem situation. Such models can suggest or substantiate algorithmic techniques, predict critical parameter values such as thresholds, and provide performance measures. As an initial step, we have chosen to model one aspect of FLIR imagery based on the simplified assumption that targets appear as homogeneous "hot" regions within a homogeneous "cooler" surround. Operations which respond to edges by assigning high values also respond to homogeneity with low values. A model which describes the transition from background to object can be used to predict a threshold gray level for separating object from background. In future work we plan to investigate a model involving the projective geometry of the image, to be used in predicting object size and orientation.

The model presented in this section is basically a first approximation to the real-world situation, since it assumes that the target and background have essentially constant gray levels (except for noise), and that the edges between target and background are ramplike. A more realistic model would take into account gradations of gray level across the image (e.g., due to range or terrain slope differences), and would treat edges as smooth transitions. (Gradations across the image may be unimportant when one processes relatively small windows, but could not be ignored

when analyzing entire frames.)

In spite of these limitations, the model does qualitatively predict the statistical measurements made on real images. It constitutes a first step in the development of more accurate models that should provide quantitative fits to real-image data.

In scene analysis it is often required to segment an image into background and object, where an object is a light area embedded in a background of darker gray level (or vice versa). A simple segmentation procedure is to select a gray level threshold to discriminate the pixels; pixels with gray level higher than the threshold are mapped into the object class and the rest into the background class. The optimum threshold for discrimination, given by Bayes decision theory, is the one that satisfies

$$p(t|\omega_0)P(\omega_0) = p(t|\omega_1)P(\omega_1) \quad (1)$$

where t is the gray level threshold; ω_1 and ω_0 are the two classes (object and background respectively); $P(\cdot)$ and $p(\cdot)$ are a priori and conditional probabilities. When the component density parameters or the prior probabilities are unknown, the location of the valley between the two modes of the mixture density, corresponding to the two modes of the component densities (assuming they are unimodal and "well separated"), is chosen as the threshold. But often such a threshold cannot be readily derived from the mixture histogram.

In the following we develop a model for optimal threshold selection which takes more accurate account of image structure.

B1. The noise-free case in one dimension

Let Fig. 4 represent the spatial gray level variation of a one-dimensional image. The background and object have gray levels s_0 and s_1 and are spatially connected by a ramp edge. Let e be the output of an edge operator*. Assuming the edges on both sides of the object are equally steep, the joint (gray level, edge value) histogram $p(s,e)$ will be as shown in Fig. 5. The impulse functions at $(s_0,0)$ and $(s_1,0)$ correspond to the background and the object respectively, the strength of these impulse functions being proportional to the areas of the background and the object. At the edge, the output of the edge operator is maximum ($= e_m$) and is constant for all gray levels at the edge. For $s_0 < s < s_1$ $p(s,e_m)$ is constant. Let

L = total length of the image

$d = |s_1 - s_0|$ (see Fig. 2)

w = width of edge on either side of object (see Fig. 1)

and $e(i) \triangleq |s(i) - s(i-1)|$. Then

$$e_m = \frac{d}{w} \quad (2)$$

$$\text{probability } P(e=e_m) = \frac{2w}{L}$$

$$\text{and } p(s,e_m) = \frac{P(e_m)}{d} = \frac{2w}{Ld}, \text{ for } s_0 < s < s_1 \quad (3)$$

Substituting eqn. (2) in eqn. (3) we get

$$p(s,e_m) = \frac{2}{Le_m} \quad (4a)$$

*This output will be referred to here, generically, as the gradient.

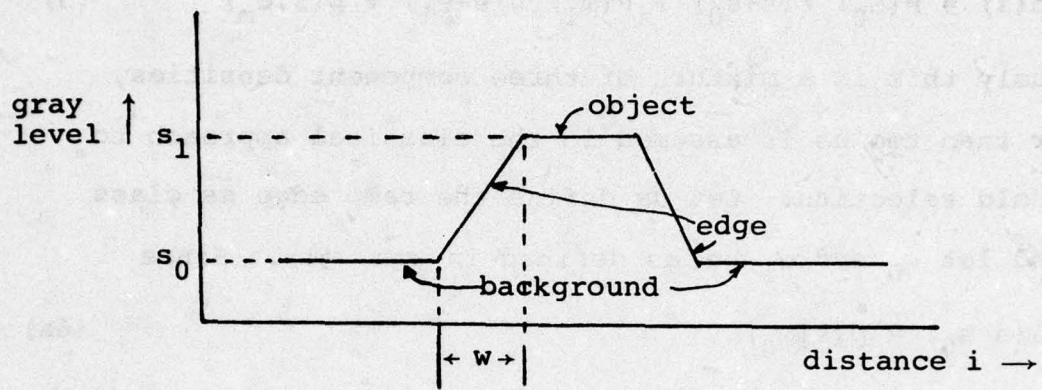

Fig. 4

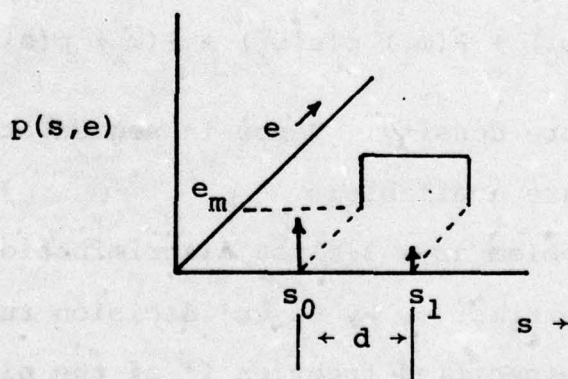

Fig. 5

Thus

$$p(s, e_m | s_0 < s < s_1) \propto \frac{1}{e_m} \quad (4b)$$

where \propto denotes "is proportional to". Now the mixture density of gray level s is

$$p(s) = P(\omega_0) \delta(s-s_0) + P(\omega_1) \delta(s-s_1) + p(s, e_m) \quad (5)$$

Obviously this is a mixture of three component densities, rather than two as is assumed in the classical approach to threshold selection. Let us define the ramp edge as class ω_2 , and let ω_0 and ω_1 be as defined in eqn. (1). Since

$$\delta(s-s_0) = p(s|\omega_0) \quad (6a)$$

$$\delta(s-s_1) = p(s|\omega_1) \quad (6b)$$

and $p(s, e_m) = p(s|e=e_m) P(e_m)$

$$= p(s|\omega_2) P(\omega_2) = \frac{1}{d} \cdot \frac{2w}{L} \quad (6c)$$

eqn. (5) can be written as

$$\begin{aligned} p(s) &= P(\omega_0) \delta(s-s_0) + P(\omega_1) \delta(s-s_1) + P(\omega_2) \frac{1}{d} \\ &= P(\omega_0) p(s|\omega_0) + P(\omega_1) p(s|\omega_1) + P(\omega_2) p(s|\omega_2) \end{aligned} \quad (7)$$

which defines the mixture density. Hence in segmentation, the following choices are available:

- (i) Treat the problem as a 3-class discrimination problem and extract ω_1 by Bayes' decision rule.
- (ii) Include an unspecified fraction f' of the pixels from ω_2 in ω_1 by selecting a threshold t_0 , $s_0 < t_0 < s_1$, such that t_0 discriminates between ω_0 and ω_1 (at zero gradient)

- (iii) Select a threshold t_1 to include a specified fraction f of pixels from ω_2 in ω_1 .

In choice (i) the Bayes decision rule gives a set of piecewise linear discriminant functions. In particular the decision rule is:

$$s < t_s, e < t_e \Rightarrow (s, e) \in \omega_0 \quad (8a)$$

$$s > t_s, e < t_e \Rightarrow (s, e) \in \omega_1 \quad (8b)$$

$$e > t_e \Rightarrow (s, e) \in \omega_2 \quad (8c)$$

where t_s is any threshold satisfying $s_0 < t_s < s_1$, and t_e is any threshold satisfying $0 < t_e < e_m$. The above decision rule is given by

$$(s, e) \in \omega_k \text{ if } \max_i p(s, e | \omega_i) P(\omega_i) = k. \quad (9)$$

The three discriminant functions are shown in Fig. 6. In choice (ii) the space $\Omega = \{(s, e)\}$ may first be classified into ω_2 and $\bar{\omega}_2$ by selecting a threshold t'_e , $0 < t'_e < e_m$. The set $\bar{\omega}_2$ may then be classified into ω_0 and ω_1 by selecting a threshold t_0 , $s_0 < t_0 < s_1$; however, in the final decision rule the discriminant $s = t_0$ is extended to all gradient values (e) and classifies the entire space Ω into only two classes: ω_1 and $\bar{\omega}_1$; that is, the decision rule is

$$s < t_0 \Rightarrow (s_i) \in \bar{\omega}_1 \quad (10a)$$

$$s > t_0 \Rightarrow (s_i) \in \omega_1 \quad (10b)$$

Thus the pixels $\{(s, e) \mid s > t_0, e = e_m\}$ are included in ω_1 . Essentially the threshold t_s is a Bayes classifier for all

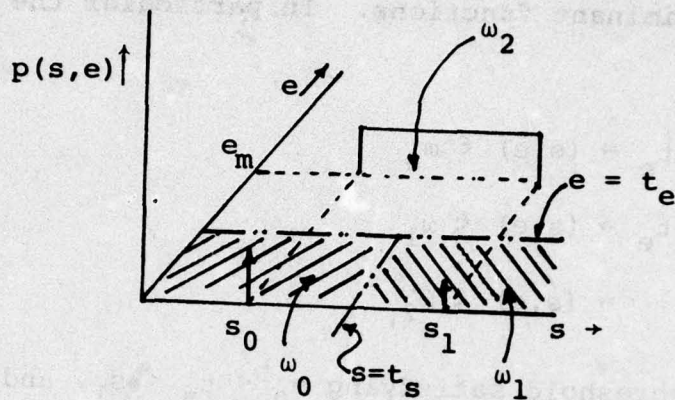

Fig. 6

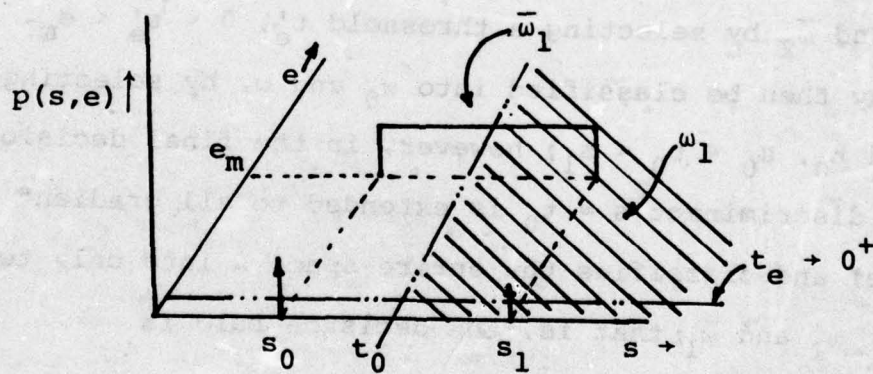

Fig. 7

pixels with zero gradient. Hence, the threshold t'_e can be chosen arbitrarily close to zero, i.e., $t'_e \rightarrow 0^+$. Thus in choice (ii) the segmentation procedure is to select a threshold t_0 that optimally classifies all pixels with gradient less than 0^+ into two classes, ω_0 and ω_1 , and then extend the threshold to all gradients as in eqn. (10) above. The fraction f' of pixels from ω_2 included in ω_1 can be easily shown to be $f' = \frac{s_1 - t_0}{d}$. The discriminant function is shown in Fig. 7. It may be noted that the threshold t'_e would satisfy the same Bayesian optimality criterion as t_e in choice (i), and t_0 would satisfy the same criterion as t_s . In other words, the decision rule (8) will remain unchanged if t_e is replaced by t'_e and t_s is replaced by t_0 . In choice (iii) a threshold t''_e is selected to classify Ω into ω_2 and $\bar{\omega}_2$. Then the threshold t_1 is determined such that

$$P_r(s > t_1 | \omega_2) = f.$$

Now t_1 is used as a gray level threshold to partition the space Ω into ω_1 and $\bar{\omega}_1$ according to the rule:

$$\begin{aligned} s > t_1 &\Rightarrow (s, \cdot) \in \omega_1 \\ s < t_1 &\Rightarrow (s, \cdot) \in \bar{\omega}_1. \end{aligned}$$

If the class conditional density of ω_2 is symmetric then $f = 0.5$ gives t_1 as the class conditional mean of ω_2 . As a variation of choice (iii) one may select t_1 as the class conditional mean regardless of the shape of the class conditional density of ω_2 . In this case every point in the edge between the object and the background is treated as a

potential candidate for the threshold and the actual threshold selected is the mean value of all such candidate thresholds. Thus the threshold t_1 is given by

$$\begin{aligned} t &= E[s|\omega_2] \\ &= E[s|e_m], \end{aligned} \tag{11a}$$

Hence

$$\begin{aligned} t &= \int_{-\infty}^{\infty} s p(s|e_m) ds \\ &= \frac{1}{d} \int_{s_0}^{s_1} s ds \\ &= \frac{1}{s_1 - s_0} \cdot \frac{s_1^2 - s_0^2}{2} \\ &= \frac{s_1 + s_0}{2} \end{aligned} \tag{11b}$$

which is not surprising. Clearly, this suggests a method for selecting the threshold: choose the points where the output of the edge operator is high ($e = e_m$ in the example); the mean gray level of such points gives the threshold.

B2. Extension to two dimensions

In extending the simple case of Fig. 1 to two-dimensional space the following assumptions are made: the object is of constant gray level s_1 and is convex, the background is of constant gray level s_0 , and at the edge of the object gray levels increase from s_0 at the background to s_1 at the object monotonically and at a constant rate (see Fig. 8).

The structure of the joint histogram of (s,e) in this case remains basically the same as in the one-dimensional case with one major exception. If two constant gray level contours c_0 and c_1 are drawn through the points in the edge region, with the gray level of c_0 greater than that of c_1 , then because of the shape of the object, c_0 contains fewer pixels than c_1 does. Three simple observations can be made regarding these contours: the number of pixels in a contour is proportional to the length of the contour; the length of the contour monotonically increases as the distance of the contour from the object (measured in a direction orthogonal to the contour) increases; and the gray level of the contour decreases linearly as the distance from the object increases. Thus $p(s|e_m)$ is a monotonically decreasing function from s_0 to s_1 . In the simplest case of circular object shape (and circular contours) this function can be shown to be linear, as shown in Fig. 9. If the Laplacian is used as the edge operator then instead of a monotonic function $p(s|e_m)$ will be two delta functions at $s = s_0$ and $s = s_1$.

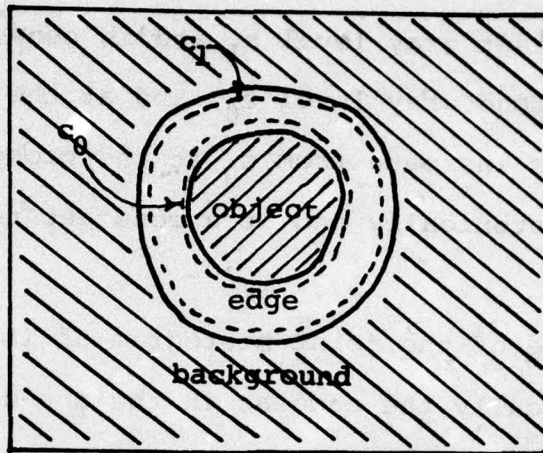

Fig. 8

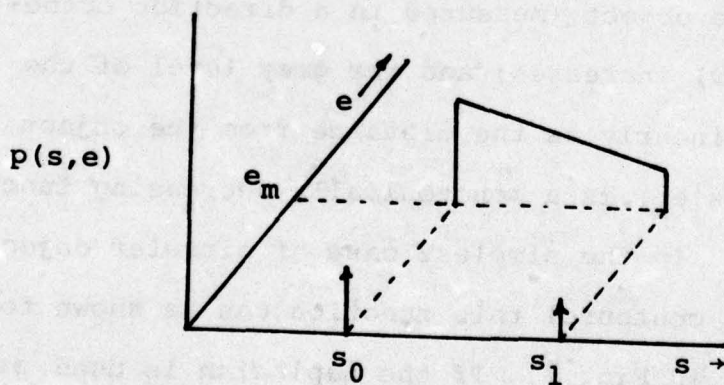

Fig. 9

However, in either case, the density $p(s,e)$ is still a mixture of three components and the three decision rules corresponding to the three choices still hold. Thus a threshold can still be selected by taking the conditional expectation of the gray level with the condition $e = e_m$.

B3. The Effect of Noise

Let the noise present in a scene be i.i.d (independent identically distributed) with zero mean normal distribution (variance = σ^2). The new gray level in the two-dimensional image space is

$$x(i,j) = s(i,j) + n(i,j) \quad (12)$$

where s is the original gray level as shown in Fig. 8 and Fig. 9, n is the normally distributed noise, and $x(i,j)$ is the gray level of the noisy image at (i,j) . Clearly the noise is independent of the three classes ω_0 , ω_1 , and ω_2 . Thus the components of the mixture density are given by the convolution of the noise density with the original component densities. Specifically

$$\begin{aligned} p(x|\omega_0) &= p(s|\omega_0) * p(n) \\ &\sim N(s_0, \sigma^2) \end{aligned} \quad (13a)$$

$$\begin{aligned} p(x|\omega_1) &= p(s|\omega_1) * p(n) \\ &\sim N(s_1, \sigma^2) \end{aligned} \quad (13b)$$

$$p(x|\omega_2) = p(s|\omega_2) * p(n) \quad (13c)$$

The density function for ω_2 , unfortunately, is not so simple as that of ω_0 or ω_1 . For the case shown in Fig. 9 the general shape of the component densities is as shown in Fig. 10. Thus it may not be feasible to select the threshold by locating the valley, in the mixture density, between the modes corresponding to those of $p(x|\omega_0)$ and $p(x|\omega_1)$.

To get some insight into the joint p.d.f. of gray level

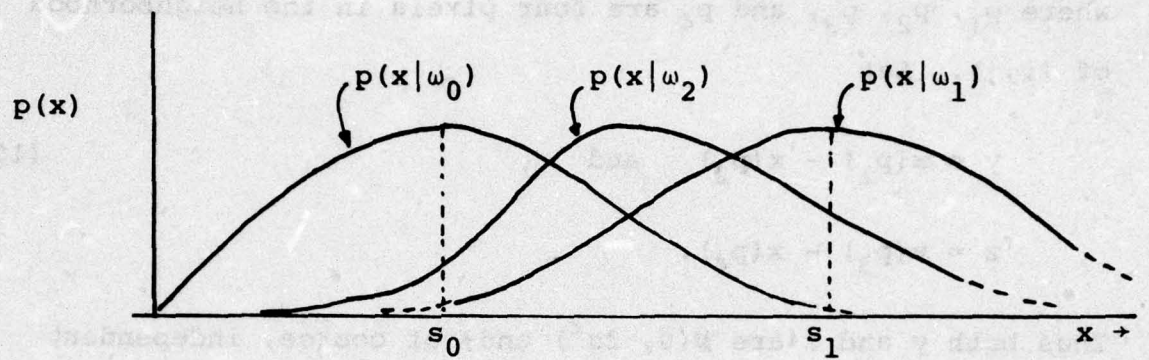

Fig. 10

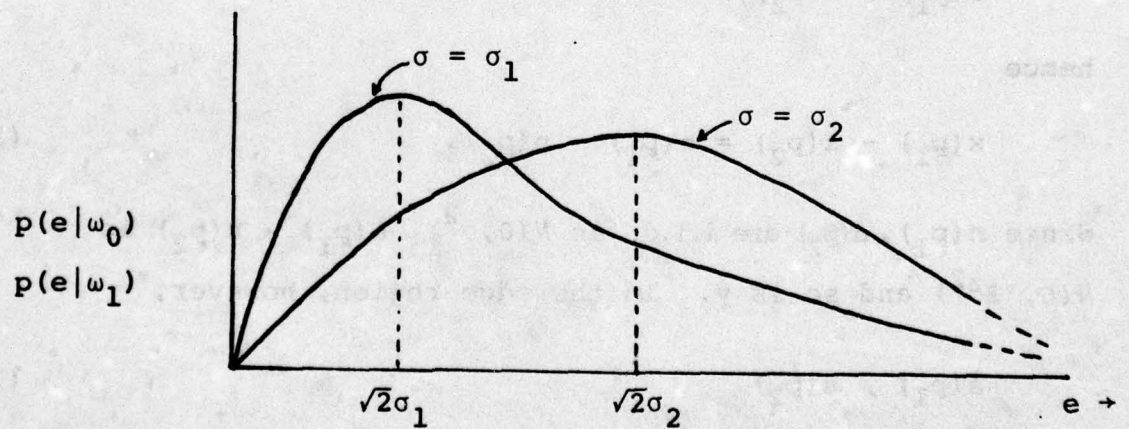

Fig. 11

and gradient let us assume that the edge operator is of the form

$$e(i,j) = \sqrt{[x(p_1) - x(p_2)]^2 + [x(p_3) - x(p_4)]^2} \quad (14)$$

where $p_1, p_2, p_3,$ and p_4 are four pixels in the neighborhood of (i,j) . Let

$$y = x(p_1) - x(p_2) \quad \text{and} \quad (15a)$$

$$z = x(p_3) - x(p_4).$$

Thus both y and z are $N(0, 2\sigma^2)$ and, of course, independent in both the background and the object region. This is true because

$$x(p_1) - x(p_2) = s(p_1) + n(p_1) - s(p_2) - n(p_2), \quad (16)$$

and in the background as well as in the object region

$$s(p_1) = s(p_2), \quad (17a)$$

hence

$$x(p_1) - x(p_2) = n(p_1) - n(p_2). \quad (17b)$$

Since $n(p_1), n(p_2)$ are i.i.d. as $N(0, \sigma^2)$, $n(p_1) - n(p_2)$ is $N(0, 2\sigma^2)$ and so is y . In the edge region, however,

$$s(p_1) \neq s(p_2) \quad (18a)$$

$$s(p_3) \neq s(p_4). \quad (18b)$$

Thus for ω_0 and ω_1

$$e(i, j) = \sqrt{y^2 + z^2}$$

where y and z are independent $N(0, 2\sigma^2)$. Therefore $e(i, j)$ is Rayleigh distributed with p.d.f.

$$p(e|\omega_0) = p(e|\omega_1) = \frac{e}{2\sigma^2} \exp\left[-\frac{e^2}{4\sigma^2}\right] u(e) \quad (19)$$

where $u(\cdot)$ is the unit step function. The general shape of the function is shown in Fig. 11 for $\sigma = \sigma_1$ and $\sigma = \sigma_2 > \sigma_1$. The mean and variance of the gradient e in ω_0 and/or ω_1 are easily computed as

$$E[e|\omega_0] = E[e|\omega_1] = \sqrt{\pi}\sigma \quad (20a)$$

$$\text{Var}[e|\omega_0] = \text{Var}[e|\omega_1] = (4-\pi)\sigma^2. \quad (20b)$$

Here a few observations are in order. First of all, the presence of noise has not only spread the gray level distribution in the otherwise homogeneous region (object and background) but has spread the gradient distribution also. Secondly, the dispersion of the gradient in the otherwise homogeneous regions is directly proportional to the noise dispersion. The mean gradient in the homogeneous region also increases with the noise dispersion. For the sake of tractability, assuming independence between gradient and gray level, the joint component densities of ω_0 and ω_1 are given by the products of two normal p.d.f.'s with Rayleigh p.d.f. Both the component densities are unimodal in the bivariate space, the modes occurring at $(s_0, \sqrt{2}\sigma_1)$ and $(s_1, \sqrt{2}\sigma_1)$ for ω_0 and ω_1 , respec-

tively.

The case of the edge region, however, is complicated by the inequalities (18). Assuming that in the neighborhood of every point (i, j)

$$s(p_1) - s(p_2) = m \quad \text{and} \quad (21a)$$

$$s(p_3) - s(p_4) = n \quad (21b)$$

independent of location (i, j) , then y and z of eqn. (15) become $N(m, 2\sigma^2)$ and $N(n, 2\sigma^2)$, respectively. Hence in the edge region the cumulative distribution function $P(e_1 | \omega_2)$ is

$$e_1 \int_0^{2\pi} \int_0^{\infty} \left[\frac{1}{4\pi\sigma^2} \exp\left[-\frac{1}{2}\left(\frac{e\cos\theta - m}{\sigma}\right)^2 + \left(\frac{e\sin\theta - n}{\sigma}\right)^2\right] \right] e \, d\theta \, e \, d\theta \quad (22a)$$

where $e \, d\theta$ is the differential area in polar coordinate system (e, θ) and the integrand in the square bracket is the joint p.d.f. of (y, z) transformed into polar coordinates by

$$y = e \cos \theta \quad (22b)$$

$$z = e \sin \theta. \quad (22c)$$

The probability density function $p(e_1 | \omega_2)$ is obtained by differentiating expression (22a) w.r.t. e_1 , which yields

$$p(e_1 | \omega_2) = \frac{e}{4\pi\sigma^2} \exp\left[-\frac{1}{4\sigma^2}(e^2 + m^2 + n^2)\right] \cdot \quad (23)$$

$$\int_0^{2\pi} \exp\left[-\frac{1}{2\sigma^2}(m\cos\theta + n\sin\theta)\right] d\theta$$

In expression (22) and eqn. (23)

$$e_m = \sqrt{m^2 + n^2}. \quad (24a)$$

Let us introduce a new variable ϕ defined by

$$\phi = \tan^{-1} \frac{m}{n}. \quad (24b)$$

In the edge region in the noise-free case ϕ gives the direction of gradient, where e_m gives its magnitude. Substituting eqn. (24) into eqn. (23) we get

$$\begin{aligned} p(e|\omega_2) &= \frac{e}{4\pi\sigma^2} \exp\left[-\frac{1}{4\sigma^2}(e^2+e_m^2)\right] \int_0^{2\pi} \exp\left[-\frac{ee_m}{2\sigma^2} \sin(\phi+\theta)\right] d\theta \\ &= \frac{e}{4\pi\sigma^2} \exp\left[-\frac{1}{4\sigma^2}(e^2+e_m^2)\right] \int_{\phi}^{2\pi+\phi} \exp\left[-\frac{ee_m}{2\sigma^2} \sin\theta\right] d\theta \end{aligned}$$

Denoting the integral $\int_{\phi}^{2\pi+\phi} [\cdot] d\theta$ by $F(\phi)$ we have

$$p(e|\omega_2) = \frac{e}{4\pi\sigma^2} \exp\left[-\frac{1}{4\sigma^2}(e^2+e_m^2)\right] F(\phi). \quad (25)$$

When $e_m = 0$, eqn. (25) will reduce to eqn. (19).

Thus now the gradient in the edge region is no longer constant as it was in the noise-free case. The joint class conditional density of ω_2 is given by the product of eqn. (25) and eqn. (13c). The mode is a function not just of m and n as before, but also of σ^2 , the noise variance. If the class conditional density in the noise-free case were uniform (as in Fig. 5) then the mode in the noisy case would be a straight line segment parallel to the x (gray level) axis.

In segmentation we still have the three choices, (i), (ii), and (iii), available to us just as in the noise-free

case, except that the corresponding decision rules must change. In choice (i) determining the thresholds corresponding to the Bayes decision was trivial in the noise-free case. For example, $p(e)$ is a mixture of two delta functions, at $e = e_m$ and $e = 0$, corresponding to $p(e|\omega_2)$ and $p(e|\bar{\omega}_2)$, respectively. Thus for all e in the range $0 < e < e_m$ we have $p(e|\omega_2) = 0$ and $p(e|\bar{\omega}_2) = 0$, and any such e is an optimal classifier; the problem is only to determine e_m from the noise-free sample picture(s), which is trivial. However, in the noisy case $p(e)$ is a mixture of p.d.f.'s given by eqn. (19) and eqn. (25) which may look as shown in Fig. 12. The Bayes discriminant function is satisfied by t_e (see Fig.12) where

$$p(t_e|\bar{\omega}_2) P(\bar{\omega}_2) = p(t_e|\omega_2) P(\omega_2); \quad (26)$$

but determining t_e now requires knowledge of the component p.d.f. parameter values and a priori probabilities. Hence t_e cannot be determined from the sample picture(s) alone. Instead one may locate the "valley" v_e (see Fig.12) in the mixture density (the mixture density can be estimated, e.g., by histogram \hat{p} , from sample picture(s)) and t_e can be estimated by v_e . Thus an alternative (for the noisy case) to the decision rule (8) is to seek valleys in the joint gray level and gradient histogram of the sample picture(s). Curves given by such valleys (see Fig. 13) can then be used as discriminants. In choice (ii), similarly, the threshold t_0 can be obtained by locating the valley v_0 in the conditional histogram $\hat{p}(x,e|e < t_e)$ where, as in the noise-free case,

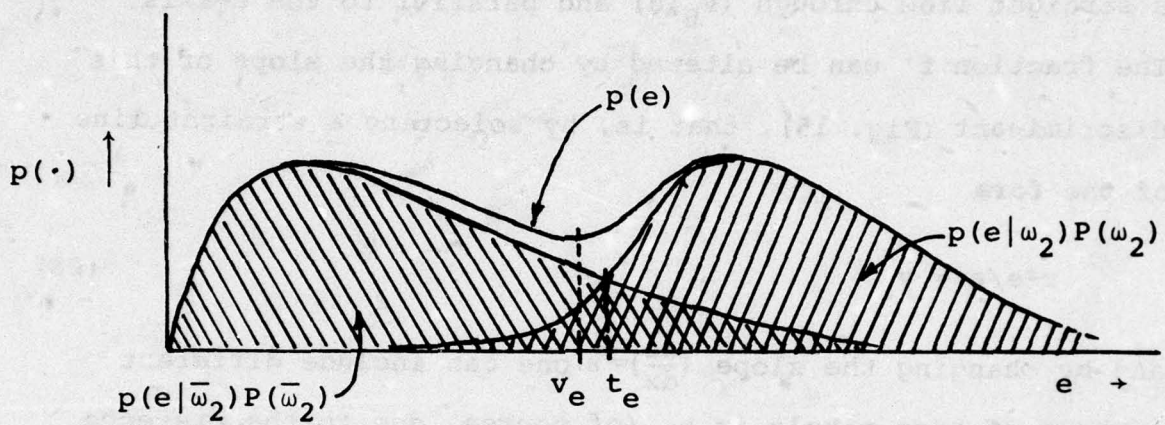

Fig. 12

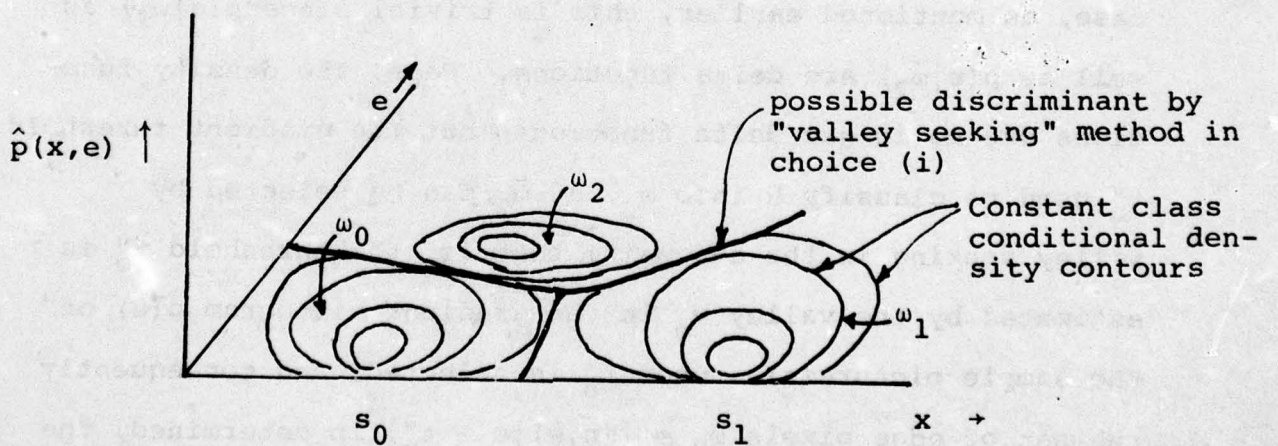

Fig. 13

$t_e \rightarrow 0^+$. The threshold t_0 is then extended to all gradient values to include an unspecified fraction f' of the edge pixels in ω_1 as shown in Fig. 14. The discriminant function, in this case, is given by

$$x = v_0, \quad (27)$$

a straight line through $(v_0, 0)$ and parallel to the e -axis. The fraction f' can be altered by changing the slope of this discriminant (Fig. 15), that is, by selecting a straight line of the form

$$x - e/a = v_0 \quad (28)$$

and by changing the slope $(\frac{de}{dx}) = a$ one can include different numbers of edge pixels in ω_1 (of course, due to the presence of noise, this process includes some background pixels in ω_1). Section E1 uses this concept. In choice (iii) the threshold t_1 is selected from the class conditional density $p(x, e | \omega_2)$. This requires isolating ω_2 from $\bar{\omega}_2$ first. In the noise-free case, as mentioned earlier, this is trivial since $p(e | \omega_2)$ as well as $p(e | \bar{\omega}_2)$ are delta functions. Here, the density functions are no longer delta functions; but the gradient threshold t_e'' , used to classify Ω into ω_2 and $\bar{\omega}_2$, can be selected by valley seeking in the e -domain; that is, the threshold t_e'' is estimated by the valley v_e in the gradient histogram $\hat{p}(e)$ of the sample picture(s). Once t_e'' is selected, and consequently the set of edge pixels $\omega_2 = \{(x, e) | e > t_e''\}$ is determined, the gray level threshold t_1 can be determined, as in the noise-free case, either by

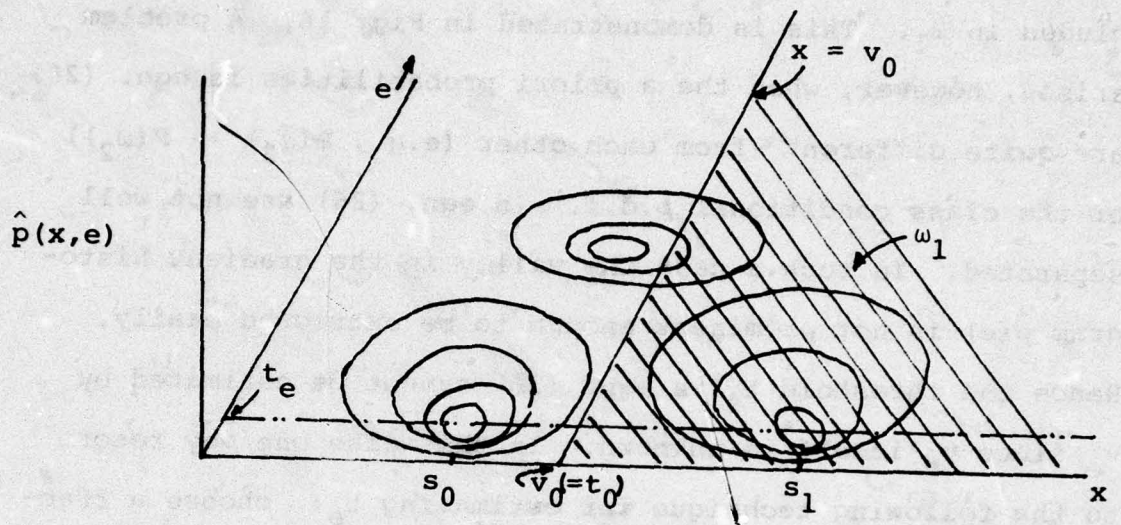

Fig. 14

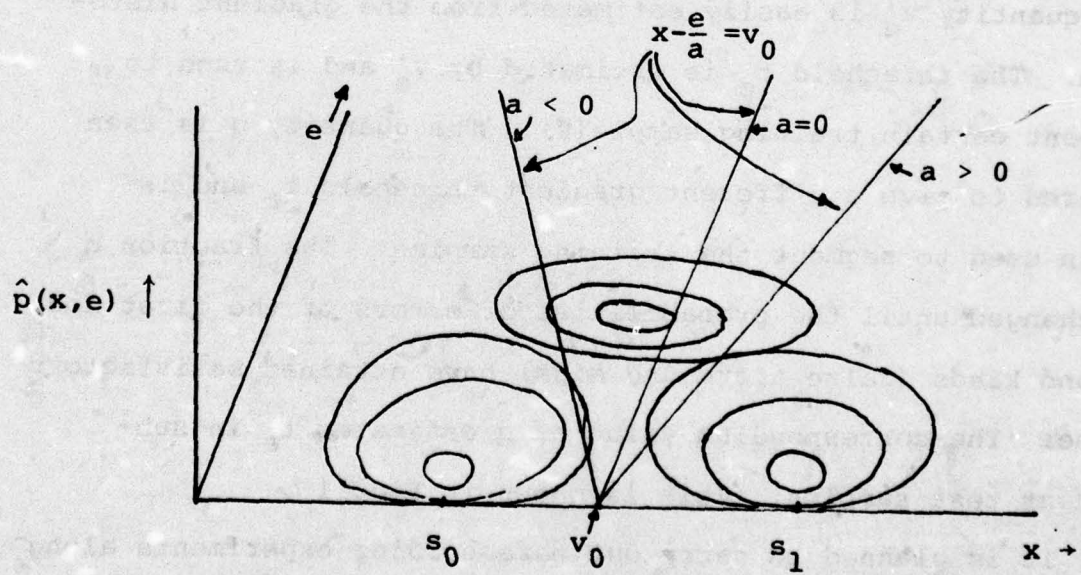

Fig. 15

$$\Pr(x > t_1 | \omega_2) = f \quad (29a)$$

or by

$$t = E[x | \omega_2] \quad (29b)$$

where f is the specified fraction of edge pixels to be included in ω_1 . This is demonstrated in Fig. 16. A problem arises, however, when the a priori probabilities in eqn. (26) are quite different from each other (e.g., $P(\bar{\omega}_2) \gg P(\omega_2)$) or the class conditional p.d.f.'s in eqn. (26) are not well separated. In such a case the valley in the gradient histogram $\hat{p}(e)$ is not prominent enough to be extracted easily. Hence the threshold t_e in eqn. (26) cannot be estimated by v_e since v_e itself is unknown. In this case one may resort to the following technique for estimating t_e : choose a fraction q and determine the point v'_e such that

$$\Pr(e > v'_e) = q. \quad (30)$$

The quantity v'_e is easily estimated from the gradient histogram. The threshold t_e is estimated by v'_e and is used to segment certain training sample(s). The quantity q is then altered to give a different gradient threshold t_e and is again used to segment the training samples. The fraction q is changed until the probabilities of errors of the first and second kinds (false alarm and miss) have attained satisfactory values. The corresponding value of q estimates t_e in subsequent test samples. This is shown in Fig. 17.

It is planned to carry out thresholding experiments along the lines suggested by this model (see Sections D and E1 for

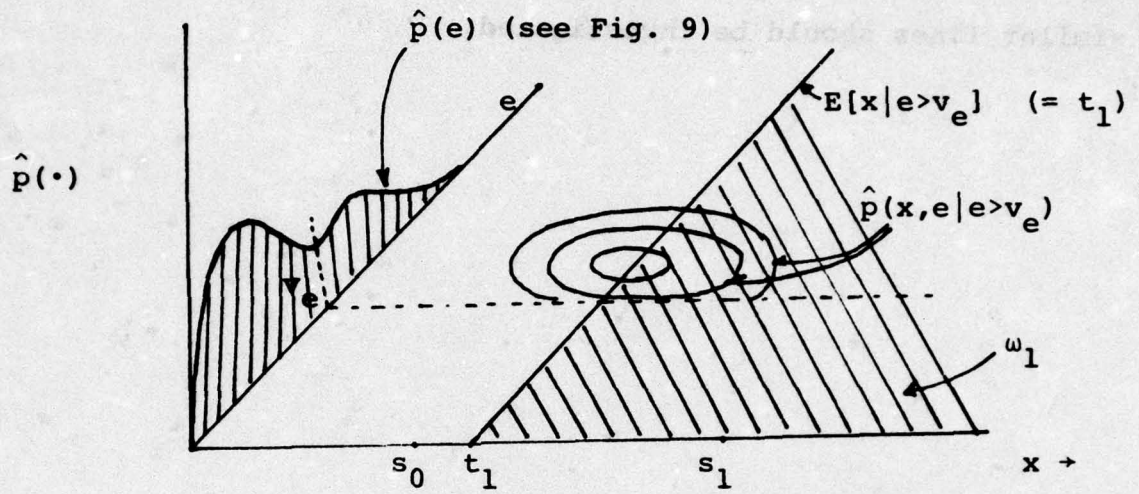

Fig. 16

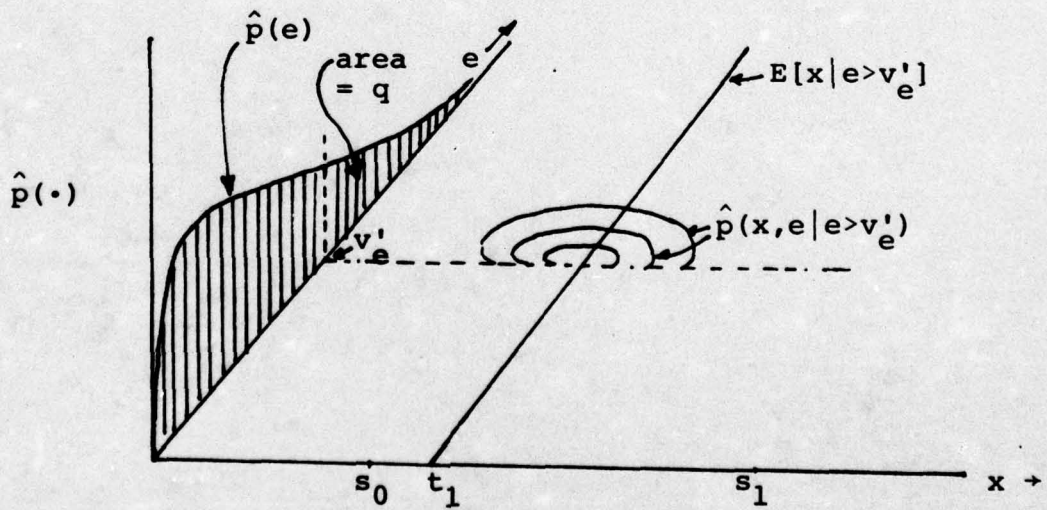
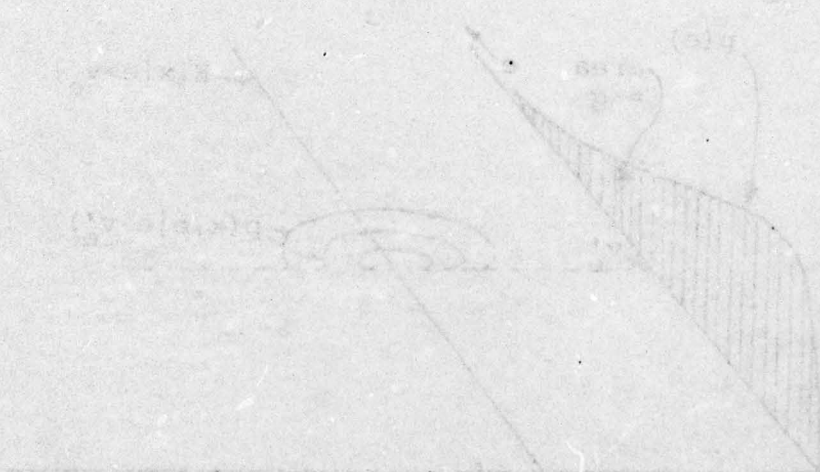
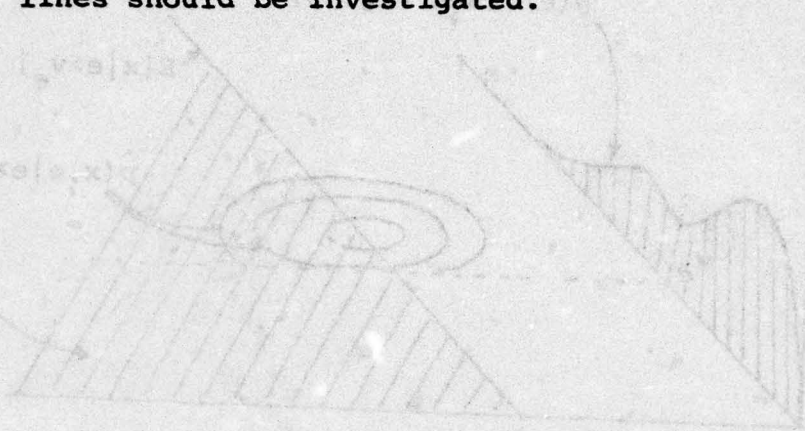

Fig. 17

some first steps in this direction), and to refine the model as necessary. Meanwhile, it is felt that the model has provided important insights into the use of local image property statistics in image segmentation. Other approaches along similar lines should be investigated.



C. Automatic Object Detection

Given an image divided into windows which may or may not contain targets, it is necessary to eliminate "noise" windows which contain no discernible objects. Subsequently, those windows containing objects can be analyzed to determine whether, in fact, the objects are targets.

A variety of techniques are available for testing whether a window is of sufficient interest to merit further processing. The a priori probability of occurrence of a "noise" window depends on the type of terrain being imaged. A hilly, wooded scene might, for example, contain many objects, while a flat desert scene might consist largely of empty windows. Terrain features such as hillocks and roads will also contribute objects for further analysis.

Later processing has the task of extracting the objects and classifying them as targets or non-targets based on shape features, gray level, size, texture, etc. This processing generally requires thresholding to segment the scene. Automatic threshold selection is treated in Section D. However, in the case of a noise window, choosing a threshold is not only futile but dangerous, in that segmentation, by its nature, will often find spurious "objects" in a noise window.

We are investigating methods of discovering noise windows based on the spatial distribution of gray levels in the window. Noise windows are generally homogeneous, and so the central moments evaluated on the whole window should

have high values, since there is no concentration of gray level. On the other hand, windows containing objects should have lower moment features. In Table 2 are displayed the moment values for 10 noise windows and 30 target windows. A classification experiment using the Fisher linear discriminant produced the following confusion matrix:

| | <u>Classified as</u> | |
|--------|----------------------|---------------|
| | <u>Noise</u> | <u>Target</u> |
| Noise | 8 | 2 |
| Target | 11 | 19 |

A large number of the misclassified targets were small, indistinct, and located on uniform backgrounds. Inasmuch as the misclassified targets were successfully thresholded (see Section D), it seems likely that the statistical uniformity of 95% of the window obscured the hotter target region.

A second experiment based not on the gray level image but on the output of a difference operator (absolute differences of 8x8 averages) showed that moment features may respond better to clusters of edge values than to clusters of gray values. In this experiment the confusion matrix was $\begin{pmatrix} 8 & 2 \\ 5 & 25 \end{pmatrix}$. Here again, 4 of the 5 misclassified targets were of the small indistinct variety. (See Tables 2c, 2d for further details.)

Another experiment was performed to investigate the SPAN technique [1, 2] as a method of detecting targets. This technique (SPAN = Spatial Piecewise Approximation by Neighborhoods) examines a set of neighborhoods of each

2nd Central Moments

| Image Ref. No. | Target Type | Average Gray Level | St. Dev. Gray Level | Centroid | | 2nd Central Moments | | |
|----------------|-------------|--------------------|---------------------|-----------|-----------|---------------------|-------|--------|
| | | | | \bar{x} | \bar{y} | x^2 | y^2 | xy |
| 3 | T | 22 | 5.97 | 32 | 34 | 1392 | 1526 | -1.23 |
| 6 | T | 19 | 5.45 | 32 | 34 | 1368 | 1506 | -6.41 |
| 11 | T | 22 | 5.59 | 32 | 33 | 1397 | 1459 | -6.25 |
| 16 | T | 21 | 6.09 | 32 | 33 | 1395 | 1458 | 1.14 |
| 22 | T | 21 | 4.58 | 33 | 33 | 1429 | 1465 | -0.85 |
| 28 | T | 24 | 2.56 | 32 | 32 | 1421 | 1375 | -0.76 |
| 34 | T | 22 | 2.72 | 32 | 32 | 1365 | 1428 | -2.55 |
| 45 | T | 23 | 4.73 | 33 | 34 | 1366 | 1520 | 2.62 |
| 52 | T | 19 | 2.79 | 32 | 33 | 1404 | 1463 | -2.57 |
| 57 | T | 19 | 2.64 | 32 | 32 | 1388 | 1373 | -10.88 |
| 3 | R | 22 | 5.59 | 33 | 34 | 1456 | 1542 | .16 |
| 6 | R | 22 | 3.93 | 33 | 33 | 1425 | 1484 | -3.50 |
| 22 | R | 22 | 3.67 | 32 | 33 | 1424 | 1427 | -2.56 |
| 24 | R | 26 | 4.35 | 32 | 32 | 1353 | 1374 | 1.24 |
| 31 | R | 24 | 2.34 | 31 | 32 | 1352 | 1399 | -8.71 |
| 34 | R | 23 | 2.28 | 32 | 32 | 1396 | 1421 | 2.64 |
| 47 | R | 19 | 6.22 | 35 | 33 | 1558 | 1404 | 12.43 |
| 48 | R | 23 | 4.47 | 33 | 33 | 1429 | 1355 | -3.46 |
| 55 | R | 21 | 1.98 | 32 | 32 | 1407 | 1414 | .82 |
| 57 | R | 22 | 3.55 | 32 | 32 | 1400 | 1426 | 9.92 |
| 21 | A | 21 | 3.61 | 32 | 32 | 1400 | 1415 | 3.61 |
| 24 | A | 23 | 5.27 | 32 | 32 | 1411 | 1386 | 5.27 |
| 27 | A | 24 | 2.41 | 32 | 32 | 1387 | 1377 | 2.41 |
| 37 | A | 23 | 4.06 | 32 | 33 | 1384 | 1419 | 4.06 |
| 42 | A | 20 | 3.50 | 31 | 33 | 1356 | 1432 | -.04 |
| 44 | A | 26 | 4.95 | 34 | 32 | 1527 | 1389 | 10.85 |
| 46 | A | 22 | 3.68 | 31 | 33 | 1327 | 1427 | -.46 |
| 52 | A | 21 | 3.28 | 32 | 33 | 1377 | 1457 | 6.63 |
| 54 | A | 21 | 2.56 | 32 | 33 | 1409 | 1443 | 5.89 |
| 58 | A | 21 | 4.26 | 32 | 32 | 1392 | 1385 | 1.36 |
| 2 | N | 28 | 8.50 | 33 | 33 | 1451 | 1430 | -3.06 |
| 8 | N | 28 | 5.83 | 31 | 34 | 1287 | 1496 | -6.89 |
| 14 | N | 19 | 3.18 | 32 | 34 | 1386 | 1517 | 1.62 |
| 20 | N | 26 | 7.12 | 32 | 34 | 1408 | 1514 | 21.86 |
| 26 | N | 21 | 2.86 | 32 | 33 | 1418 | 1452 | -3.34 |
| 32 | N | 21 | 1.89 | 32 | 32 | 1385 | 1398 | .04 |
| 38 | N | 19 | 3.16 | 32 | 34 | 1395 | 1505 | 3.15 |
| 44 | N | 22 | 2.72 | 31 | 33 | 1351 | 1449 | .22 |
| 50 | N | 21 | 2.55 | 32 | 32 | 1388 | 1369 | -3.24 |
| 56 | N | 19 | 2.69 | 31 | 33 | 1355 | 1484 | 1.14 |

Table 2a. Feature values based on gray level for 30 target windows and 10 noise windows.

| Image Ref. No. | Target Type | Average Gray Level | St. Dev. Gray Level | Centroid | | 2nd Central Moments | | |
|----------------|-------------|--------------------|---------------------|-----------|-----------|---------------------|-------|--------|
| | | | | \bar{x} | \bar{y} | x^2 | y^2 | xy |
| 3 | T | 2 | 2.76 | 28 | 23 | 145 | 128 | -3.30 |
| 6 | T | 2 | 4.26 | 28 | 28 | 1508 | 1454 | 5.84 |
| 11 | T | 3 | 3.73 | 24 | 19 | 1164 | 166 | -13.27 |
| 16 | T | 3 | 4.40 | 28 | 27 | 942 | 860 | -.14 |
| 22 | T | 2 | 2.31 | 30 | 26 | 143 | 99 | -14.36 |
| 28 | T | 1 | 1.29 | 24 | 32 | 111 | 168 | -5.08 |
| 34 | T | 1 | 1.22 | 24 | 30 | 129 | 191 | -11.76 |
| 45 | T | 2 | 2.50 | 24 | 34 | 194 | 2088 | 5.76 |
| 52 | T | 1 | 1.47 | 29 | 29 | 140 | 156 | -31.80 |
| 57 | T | 0 | .99 | 23 | 29 | 193 | 208 | 47.59 |
| 3 | R | 1 | 1.28 | 27 | 29 | 164 | 172 | 5.49 |
| 6 | R | 1 | 1.74 | 26 | 28 | 164 | 120 | -20.46 |
| 22 | R | 1 | 1.41 | 34 | 18 | 98 | 117 | 20.73 |
| 24 | R | 2 | 1.74 | 29 | 23 | 146 | 142 | -4.86 |
| 31 | R | 0 | 1.12 | 25 | 30 | 90 | 110 | -1.05 |
| 34 | R | 0 | .74 | 25 | 22 | 155 | 197 | 9.26 |
| 47 | R | 4 | 4.08 | 29 | 28 | 1225 | 693 | -2.06 |
| 48 | R | 2 | 2.24 | 27 | 22 | 1617 | 123 | 5.65 |
| 55 | R | 0 | .72 | 24 | 22 | 124 | 173 | -17.50 |
| 57 | R | 1 | 1.03 | 28 | 25 | 196 | 194 | 7.39 |
| 21 | A | 1 | 2.10 | 28 | 19 | 139 | 92 | 3.36 |
| 24 | A | 1 | 2.27 | 28 | 16 | 133 | 83 | -22.20 |
| 27 | A | 0 | .97 | 23 | 32 | 126 | 141 | 40.08 |
| 37 | A | 2 | 2.27 | 27 | 25 | 126 | 135 | 12.26 |
| 42 | A | 1 | 1.95 | 21 | 18 | 117 | 129 | 16.73 |
| 44 | A | 2 | 1.71 | 28 | 28 | 165 | 164 | 1.34 |
| 46 | A | 2 | 1.89 | 24 | 23 | 97 | 151 | 18.50 |
| 52 | A | 0 | .81 | 28 | 24 | 187 | 162 | .81 |
| 54 | A | 0 | .96 | 29 | 21 | 168 | 163 | 11.24 |
| 58 | A | 1 | 1.46 | 25 | 24 | 135 | 236 | -16.75 |
| 2 | N | 1 | .98 | 25 | 24 | 167 | 181 | 28.09 |
| 8 | N | 1 | 1.26 | 24 | 26 | 180 | 190 | 21.72 |
| 14 | N | 0 | .76 | 22 | 28 | 225 | 160 | -39.28 |
| 20 | N | 3 | 3.13 | 24 | 22 | 1087 | 1036 | -14.07 |
| 26 | N | 0 | .66 | 24 | 23 | 207 | 181 | -13.57 |
| 32 | N | 0 | .50 | 21 | 25 | 198 | 251 | -20.08 |
| 38 | N | 0 | .81 | 27 | 16 | 191 | 86 | 47.41 |
| 44 | N | 0 | .45 | 27 | 17 | 197 | 139 | -2.66 |
| 50 | N | 0 | .87 | 24 | 26 | 191 | 164 | -12.29 |
| 56 | N | 0 | .70 | 29 | 18 | 172 | 152 | -67.53 |

Table 2b. Feature values based on 8x8 differences.

| <u>Feature</u> | <u>Fisher Direction</u> | <u>Misclassification Results</u> | |
|----------------|-------------------------|----------------------------------|------------------------|
| | | <u>Target Image No.</u> | <u>Noise Image No.</u> |
| Avg. G.L. | .316 | 3R | 2 |
| St. Dev. G.L. | -.946 | 6R | 50 |
| x ² | .00723 | 31R | |
| y ² | .0256 | 34T | |
| xy | .0706 | 34R | |
| Threshold | 30.5 | 45T | |
| | | 52T | |
| | | 52A | |
| | | 54A | |
| | | 55R | |
| | | 57R | |

Table 2c. Fisher linear discriminant classification experiment results using Table 2a data.

| <u>Feature</u> | <u>Fisher Direction</u> | <u>Misclassification Results</u> | |
|----------------|-------------------------|----------------------------------|------------------------|
| | | <u>Target Image No.</u> | <u>Noise Image No.</u> |
| Avg. G.L. | .199 | | 8 |
| St. Dev. G.L. | -.980 | 34R | 38 |
| x ² | .00113 | 48R | |
| y ² | .000562 | 52A | |
| xy | -.00350 | 55R | |
| Threshold | -.630 | 57R | |

Table 2d. Fisher linear discriminat classification experiment results using Table 2b data.

image point, and picks the largest neighborhood that satisfies some uniformity criterion (see below). If this neighborhood is contained in some other point's largest uniform neighborhood, it is discarded. The result of this process is a set of irredundant, maximal uniform neighborhoods that provide an approximation to the given image. The technique is described in greater detail in [1, 2].

Figures 18 and 19 illustrate the SPAN technique and its application to two FLIR windows. The uniformity criterion was based on the chi-square test for normality. If the gray level distribution in a given neighborhood satisfied this test, the neighborhood was called uniform (in the sense that its gray level population was homogeneous). The maximal uniform neighborhoods determined in this way, shown in Figure 18, do separate the target and background regions, at least crudely. The method (as currently implemented) is computationally costly, but it deserves further study as a possible means of facilitating target detection.

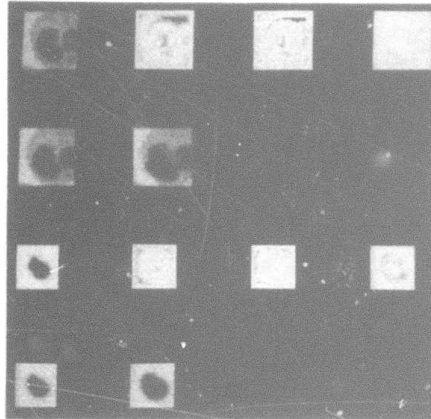

Figure 18a. Chi-square Test for Unimodality.

Cell picture: Row 1. Original image; maximal SPAN radii at each point; maximal radii with local non-maxima suppressed; detected edges.
 Row 2. Smoothed image; image reconstruction using SPAN

Chromosome: Row 3. Same as Row 1.
 Row 4. Same as Row 2.

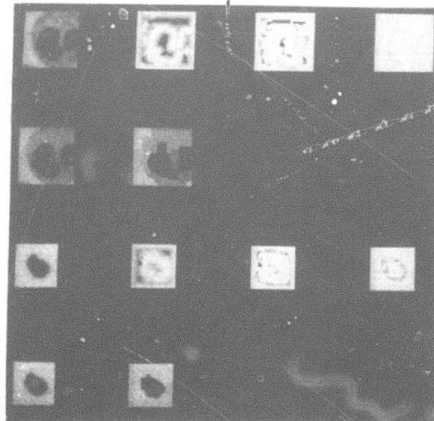

Figure 18b. Multimodality Test. Same as Fig. 18a.

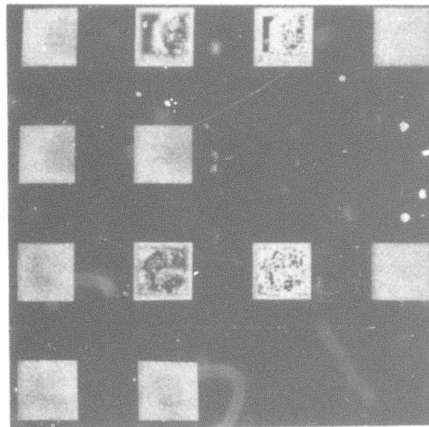

Figure 19a. Chi-square Test.

Tank window: Same as Fig. 18a, Rows
1 and 2.

APC window: Same as Fig. 18a, Rows
3 and 4.

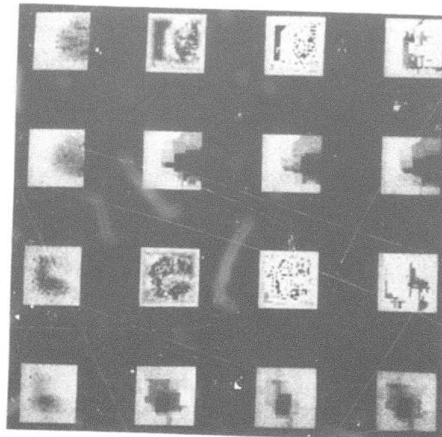

Figure 19b. Same as Fig. 19a but with enhanced
contrast. Additional reconstruc-
tions (Rows 2 and 4) using MAX, MIN
and average recombination rules.

D. Automatic Threshold Selection

In Section B a model was proposed for images consisting of objects and background, each with characteristic gray level distributions. If the gray level histogram of the image is markedly bimodal, one may choose the threshold at the valley between the two peaks (possibly shifted towards the smaller peak when using a maximum likelihood estimate). However, as may be seen in Figure 20, the smaller the object, the less likely the histogram is to exhibit strong bimodality. The background distribution engulfs the object's gray level range and tests for bimodality are inconclusive.

Our approach [3] to solving this problem has been to select from the original image a set of points that are as likely to fall within the object as within the background. If one examines the output of operators which respond to edges, then high values should correspond to points falling at or near object edges. These points are as likely to lie on the object as on the background and their mean value should correspond to the desired threshold. At first it was thought that the distribution of such points for a sufficiently coarse detector would be bimodal. However, the model of the previous section has shown the distribution to be unimodal with a peak at the mean.

A number of edge operators were tried in connection with this approach. Figure 21 shows edge values for the following operators:

Figure 20. 156 Windows - sampled to 64 X 64.
Each window has a corresponding histogram in
which grid lines identify intervals of 100 image
points. Image reference numbers refer back to
ground truth.

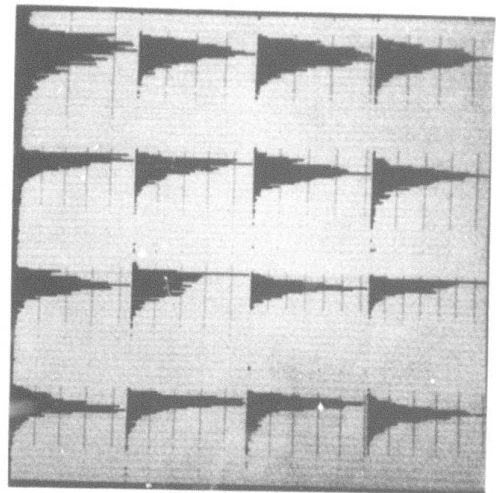
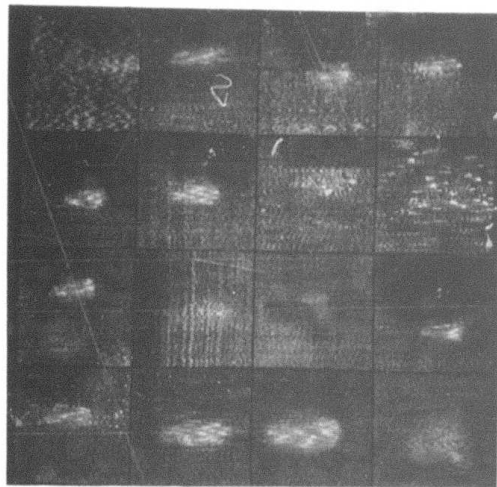

1T
2T
3T
4T
6T
8T
9T
10T
11T
12T
13T
14T
15T
16T
17T
21T

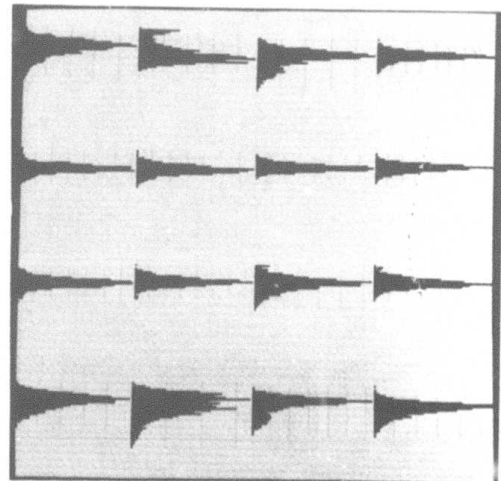
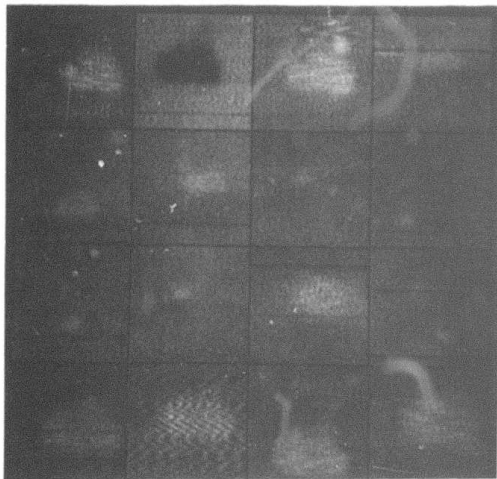

22T
23T
24T
26T
28T
31T
32T
33T
34T
35T
38T
40T
42T
43T
45T
46T

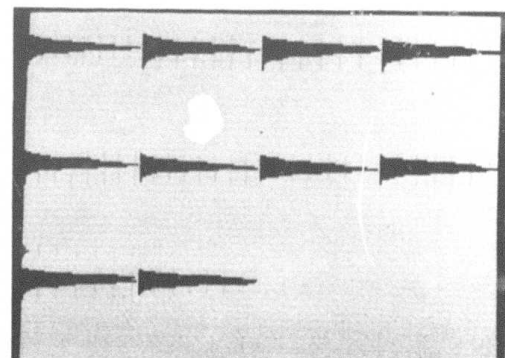
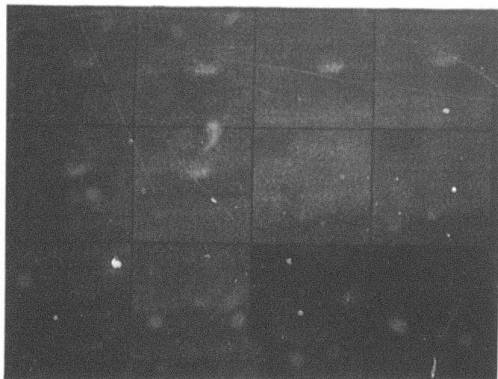

50T
51T
52T
53T
54T
55T
56T
57T
58T
59T

Figure 20a. 42 Tank windows, histograms and image reference numbers.

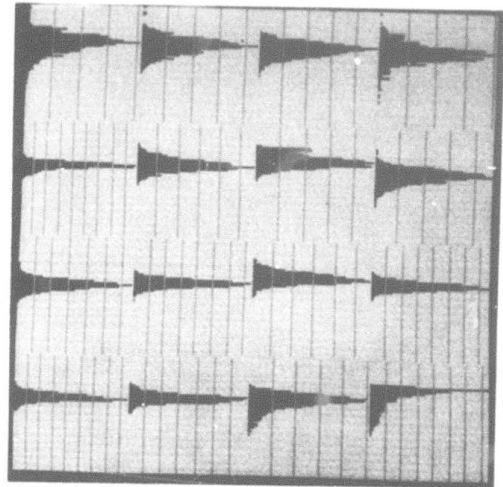
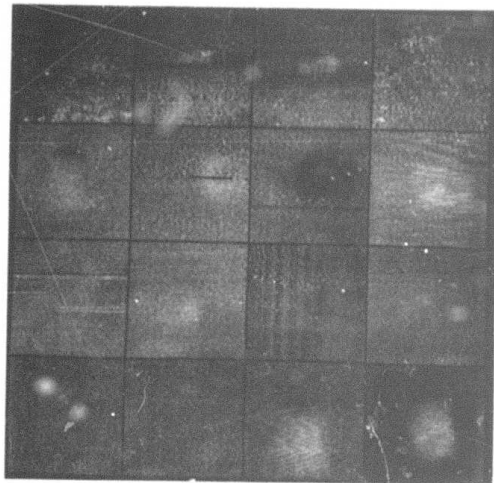

3R
4R
6R
9R
18R
22R
23R
24R
26R
31R
32R
33R
34R
35R
41R
47R

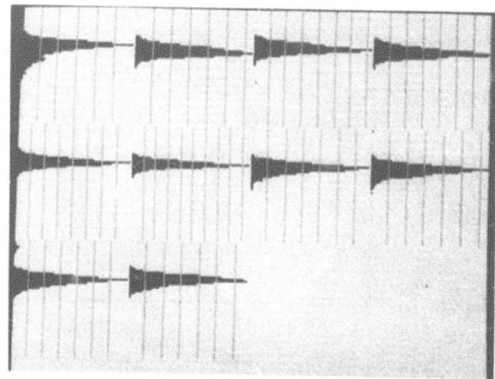
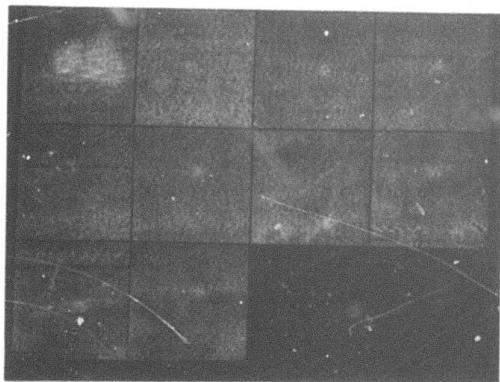

48R
51R
52R
53R
54R
55R
55R
57R
58R
59R

Figure 20b. 26 Truck windows, histograms and image ref. nos.

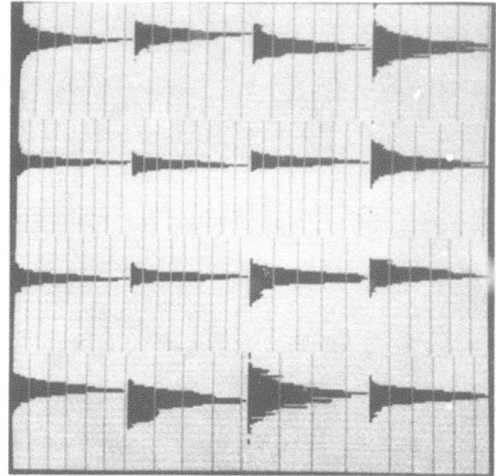
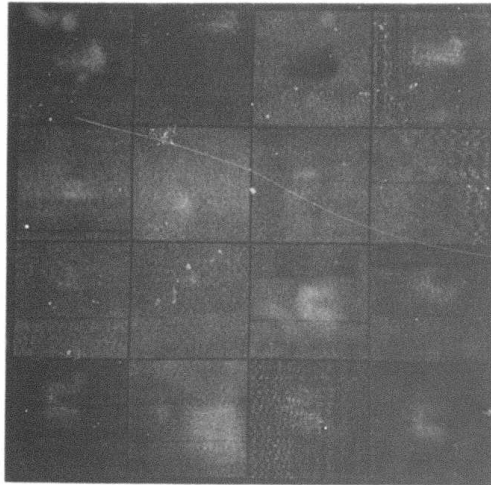

21A
22A
23A
24A
27A
28A
32A
33A
34A
35A
37A
38A
42A
44A
45A
46A

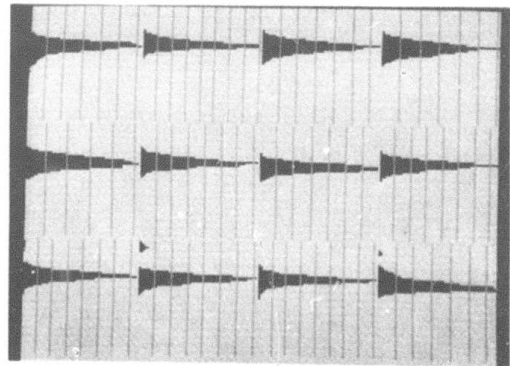
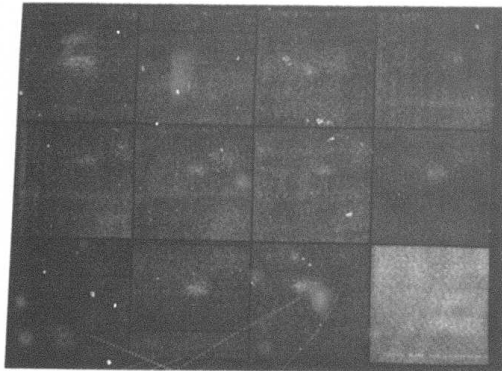

48A
50A
51A
52A
53A
54A
55A
56A
57A
58A
59A
60A

Figure 20c. 28 APC windows, histograms and image ref. nos.

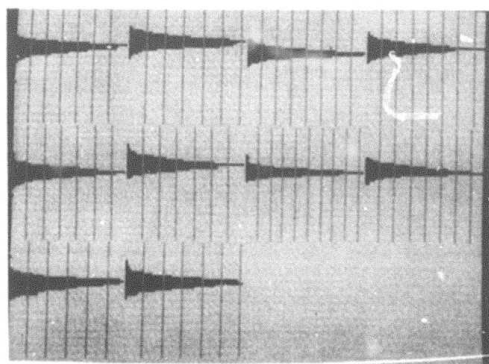
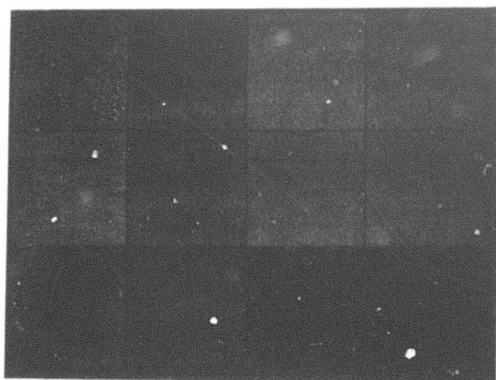
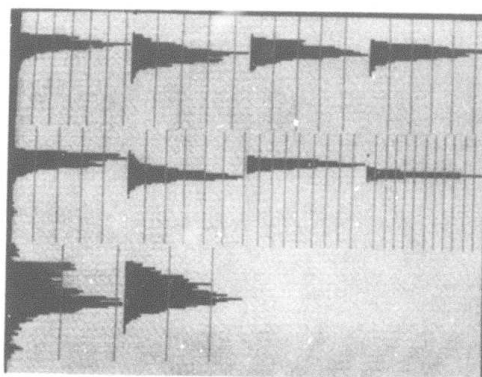
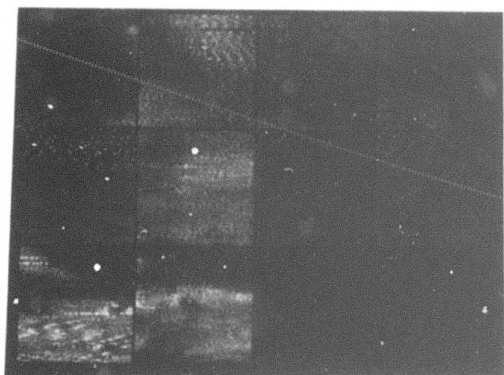
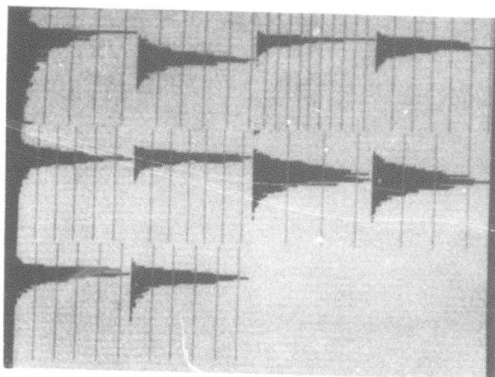
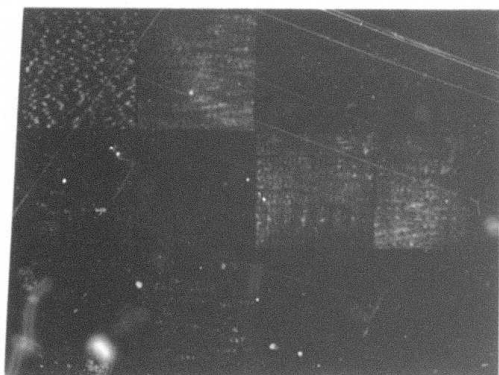

Figure 20d. 60 Noise windows and histograms. Image ref. nos. are consecutive 1N - 60N.

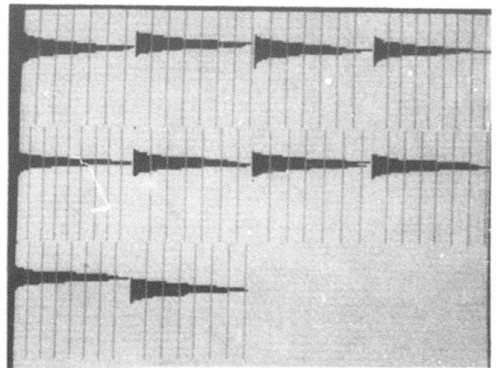
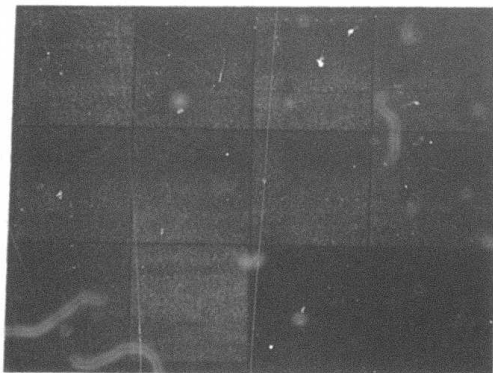
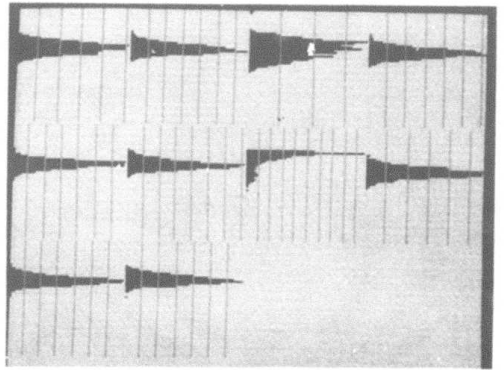
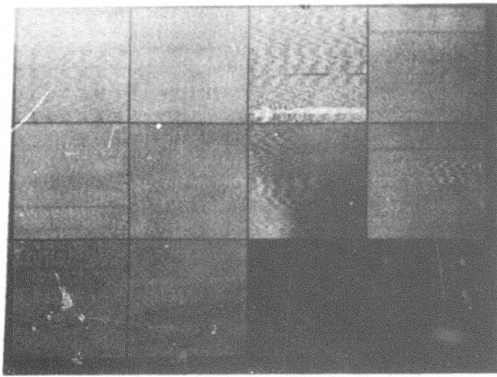
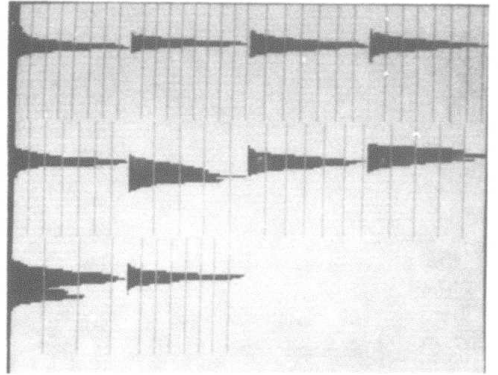
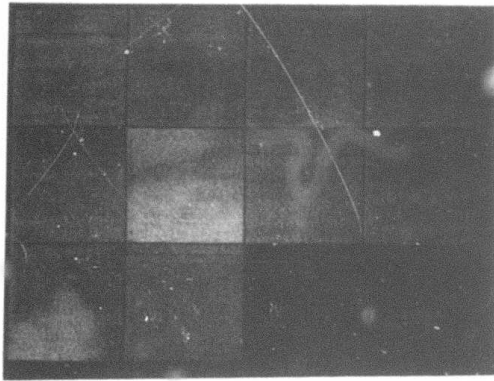
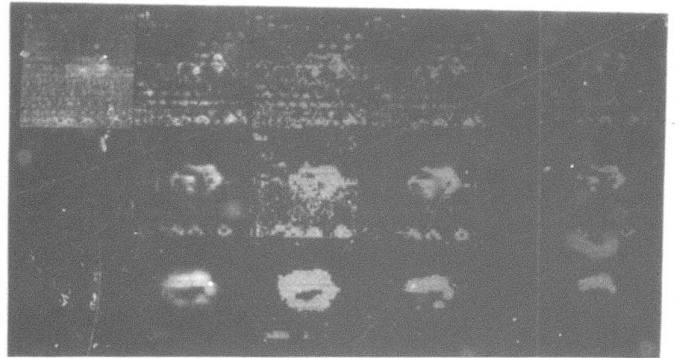
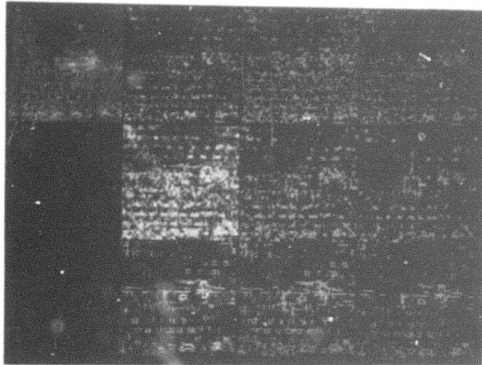

Figure 20d continued.

Figure 21. Edge values and above-threshold edge values.

| | | | |
|-------------------------|--------------------|--|--|
| <u>Key:</u> | | | |
| <u>Original image</u> | <u>Edge values</u> | <u>Above-threshold edge values 80-file 90-file</u> | <u>Above-threshold edge values 80-file 90-file 95-file</u> |
| <u>Laplacian</u> | | | <u>Edge values</u> |
| <u>Roberts gradient</u> | | <u>Original image</u> | <u>2x2 difference</u> |
| <u>3x3 gradient</u> | | <u>4x4 difference</u> | <u>4x4 difference</u> |
| | | <u>8x8 difference</u> | <u>8x8 difference</u> |

Key to images used: T = tank, R = truck, A = APC, N = noise



3T

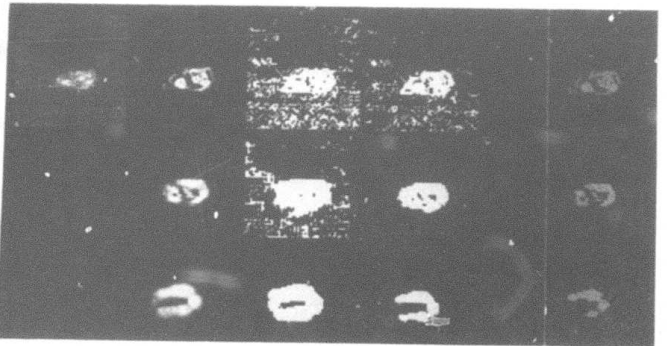
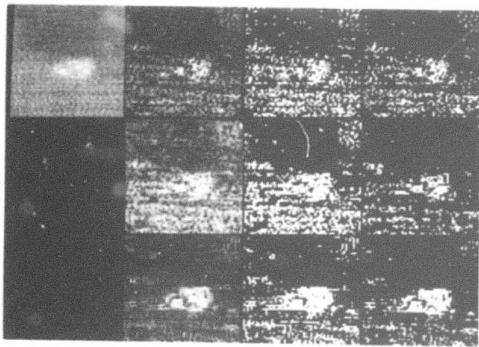

6T

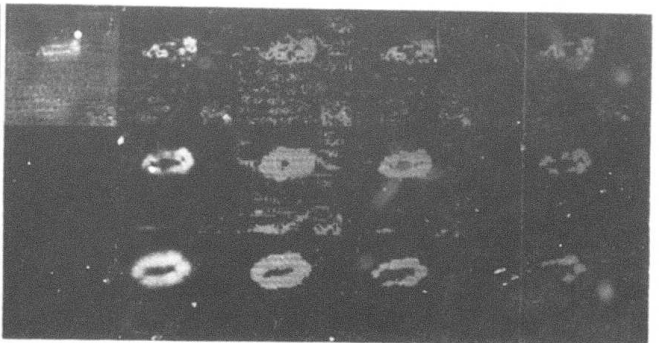

11T

Figure 21 (continued)

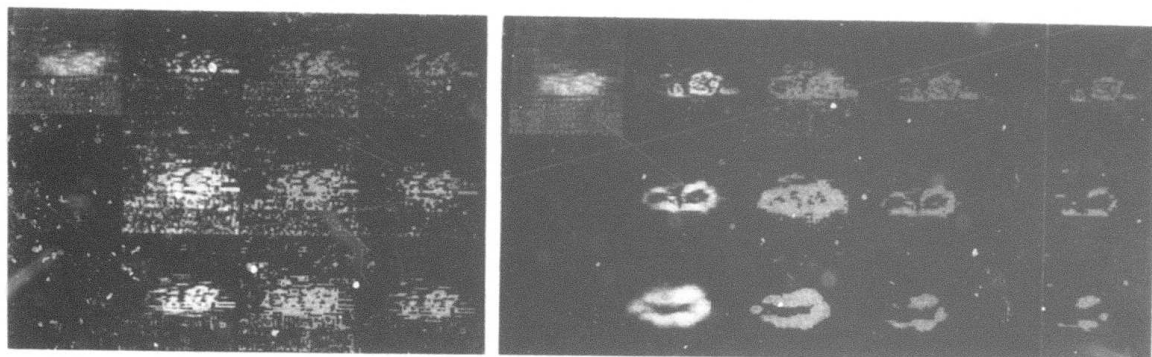

16T

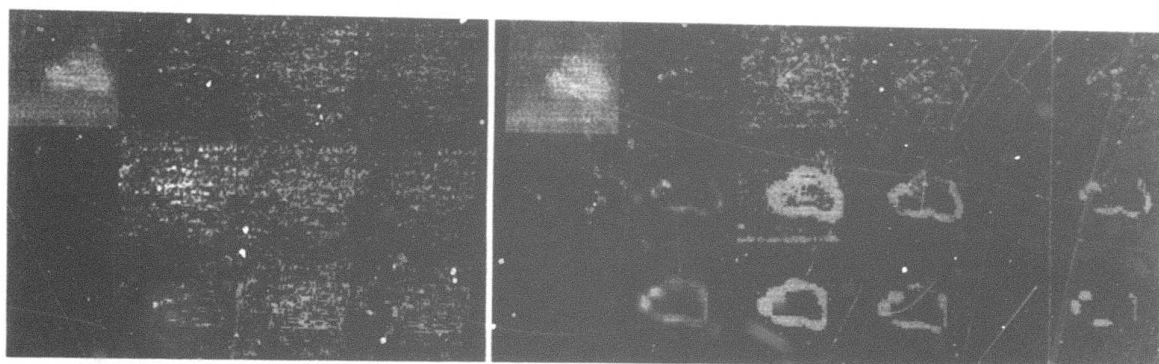

22T

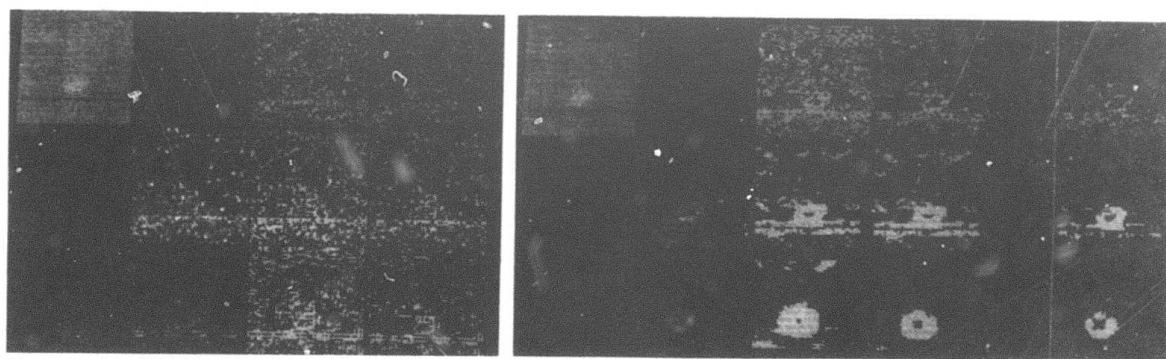

34T

Figure 21 (continued)

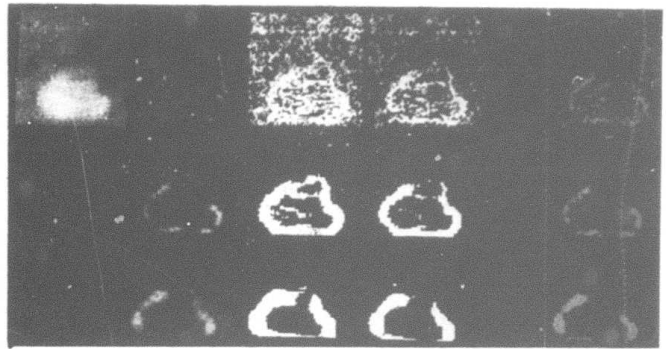
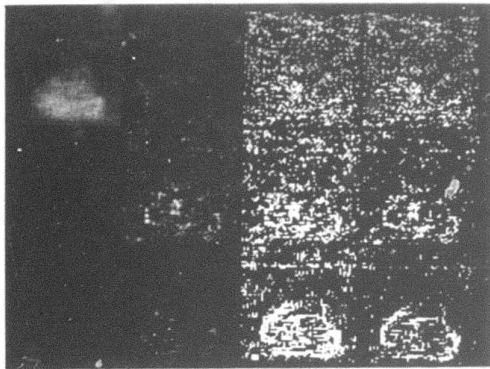

45T

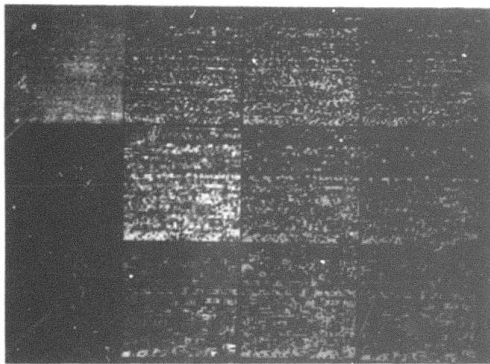

3R

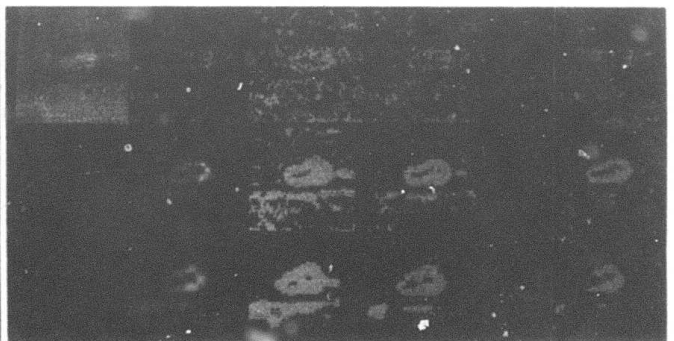
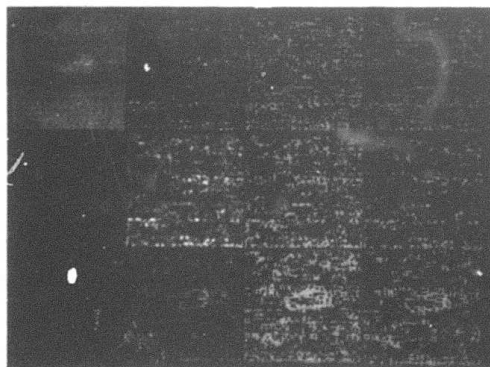

6R

Figure 21 (continued)

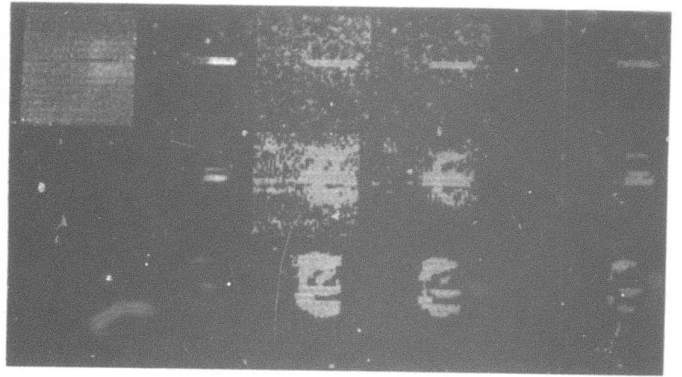
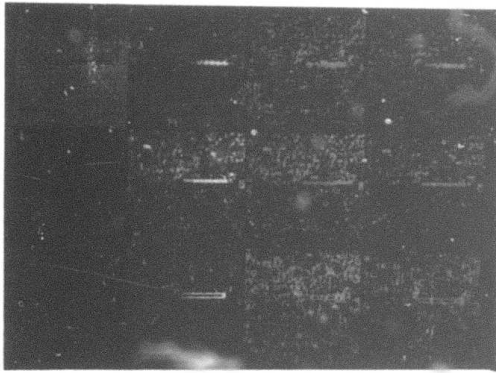

22R

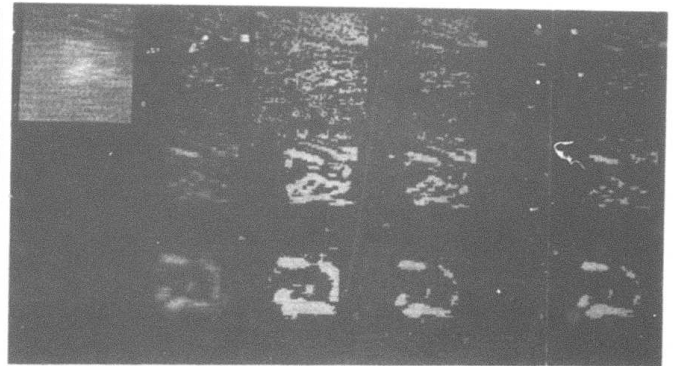

24R

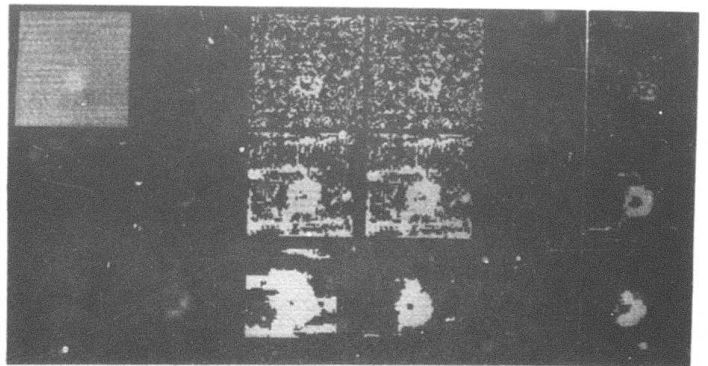
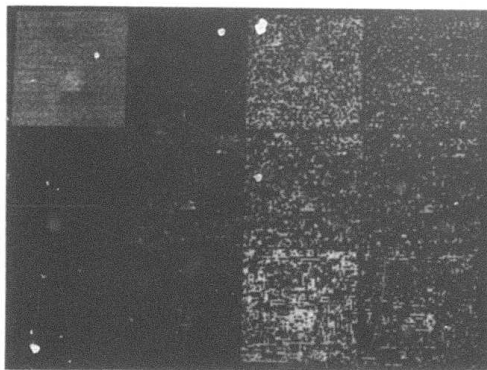

31R

Figure 21 (continued)

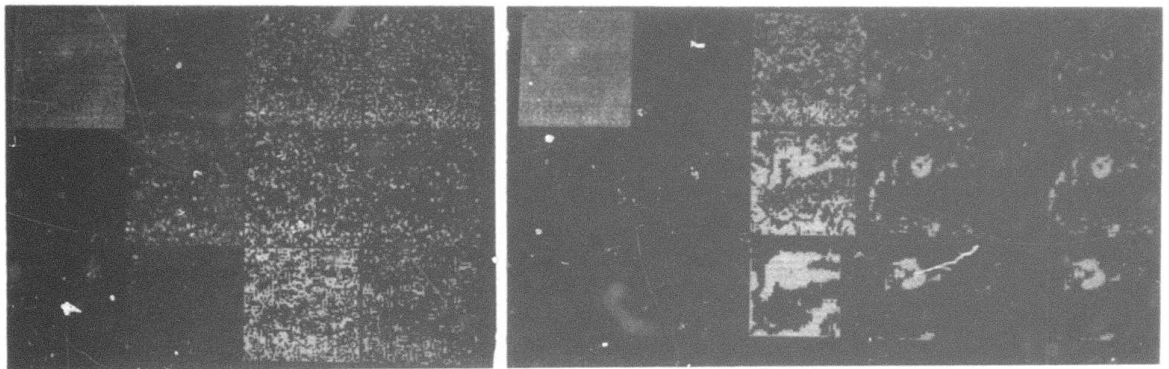

34R

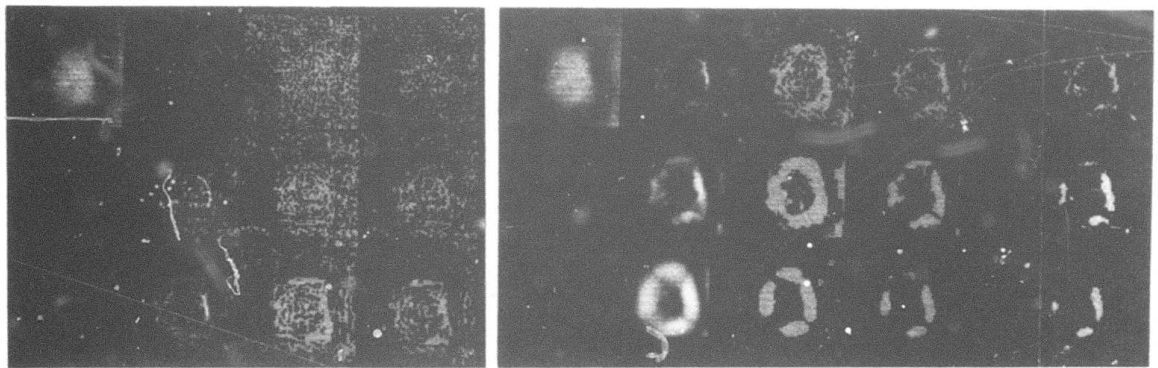

47R

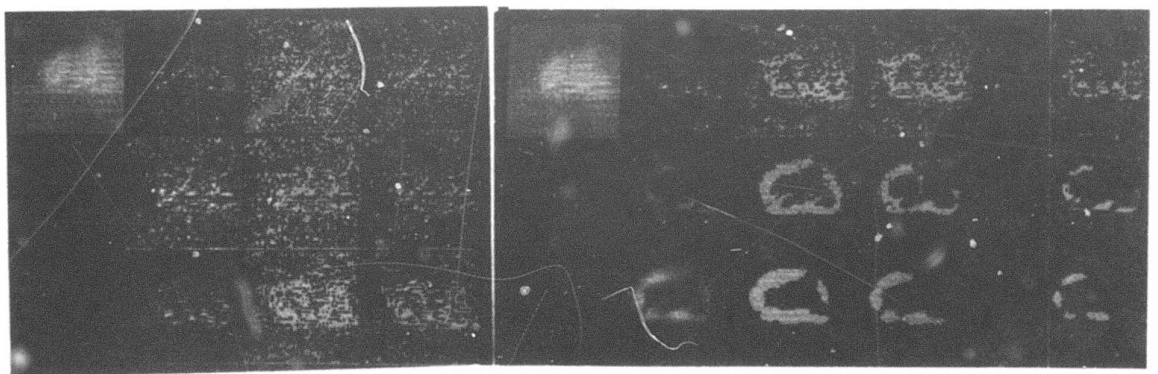

48R

Figure 21 (continued)

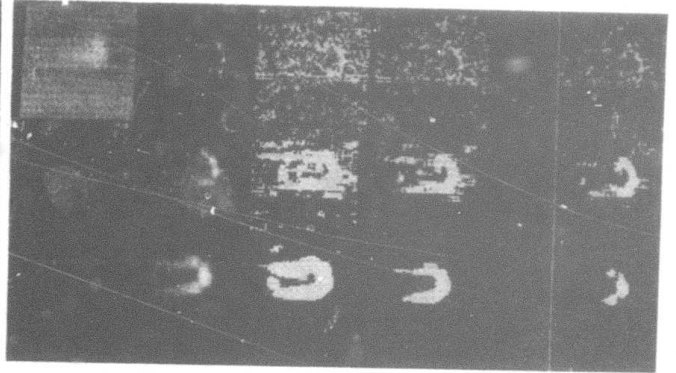

21A

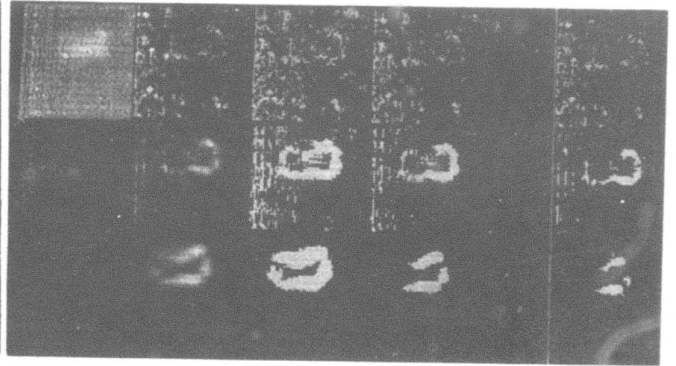
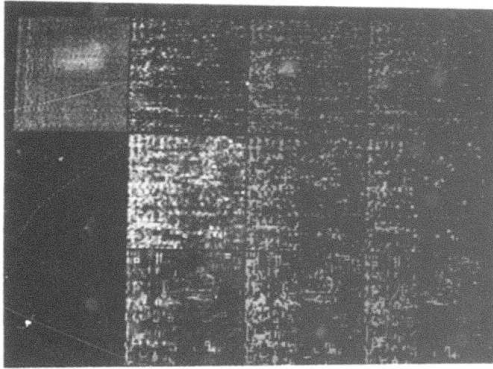

24A

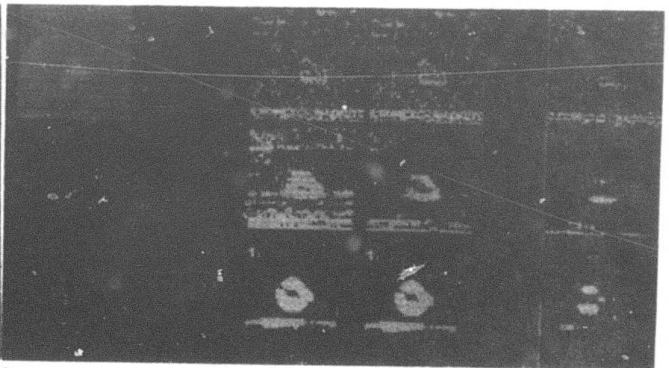
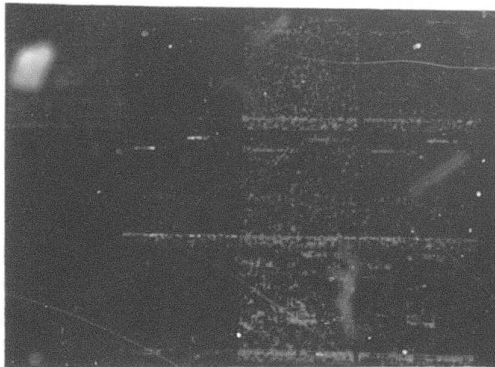

27A

Figure 21 (continued)

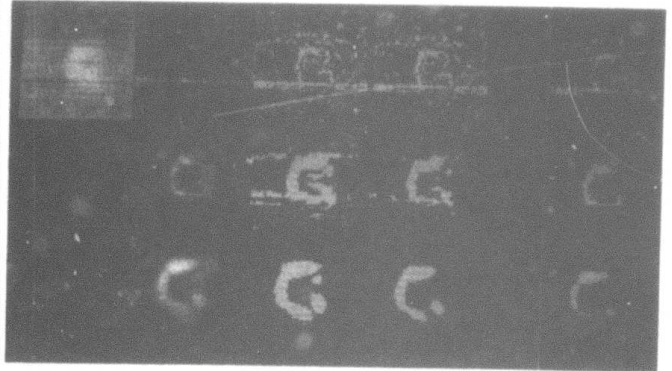
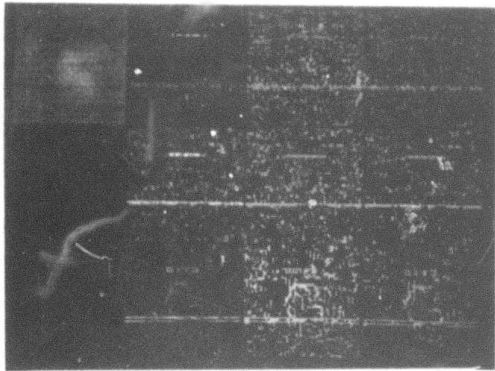

37A

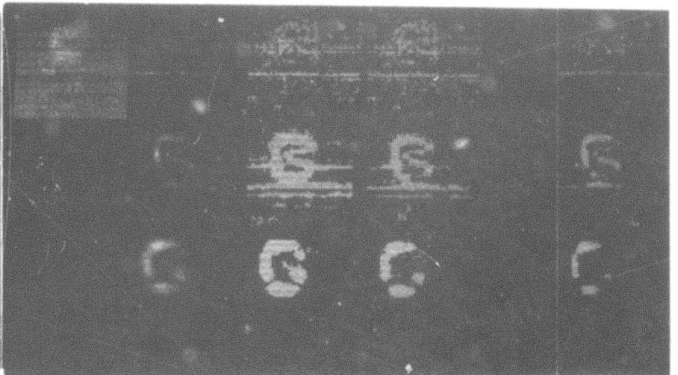
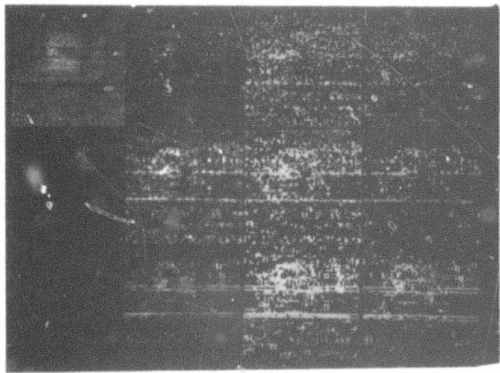

42A

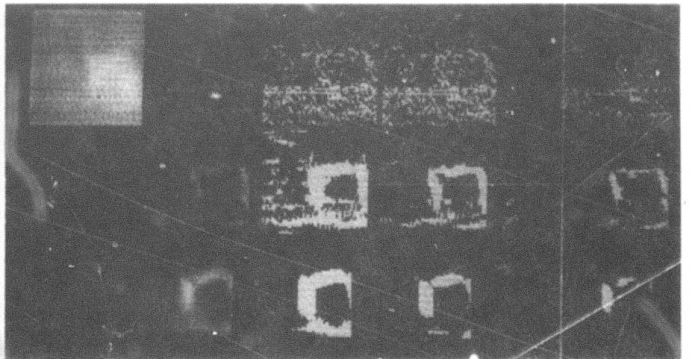
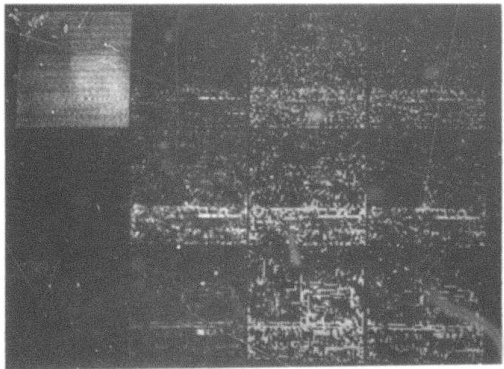

44A

Figure 21 (continued)

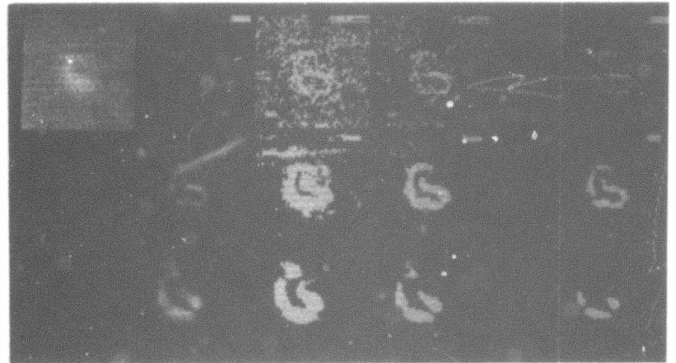
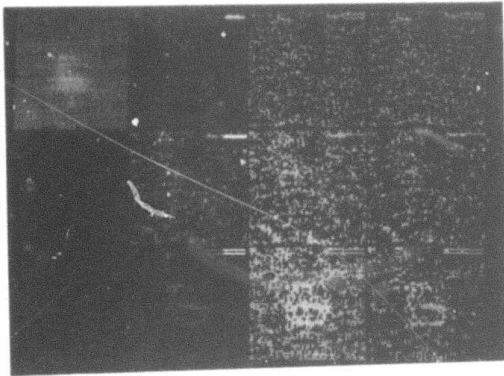

46A

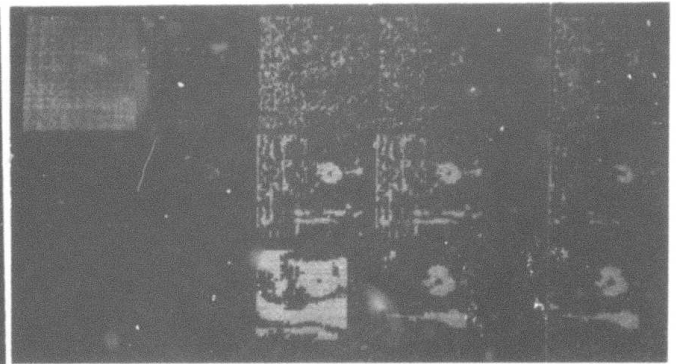

52A

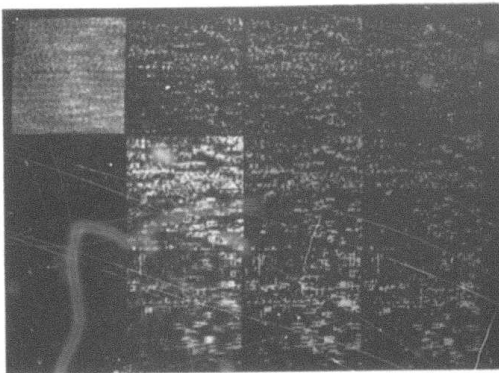

2N

Figure 21 (continued)

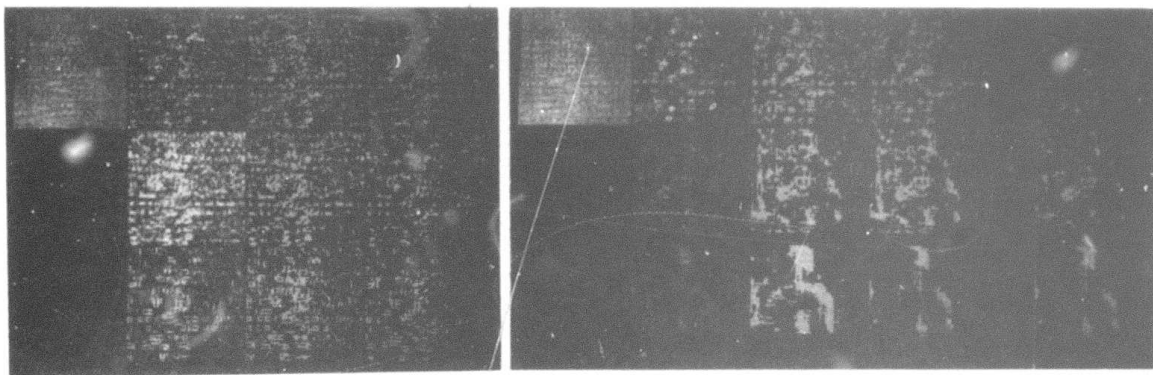

8N

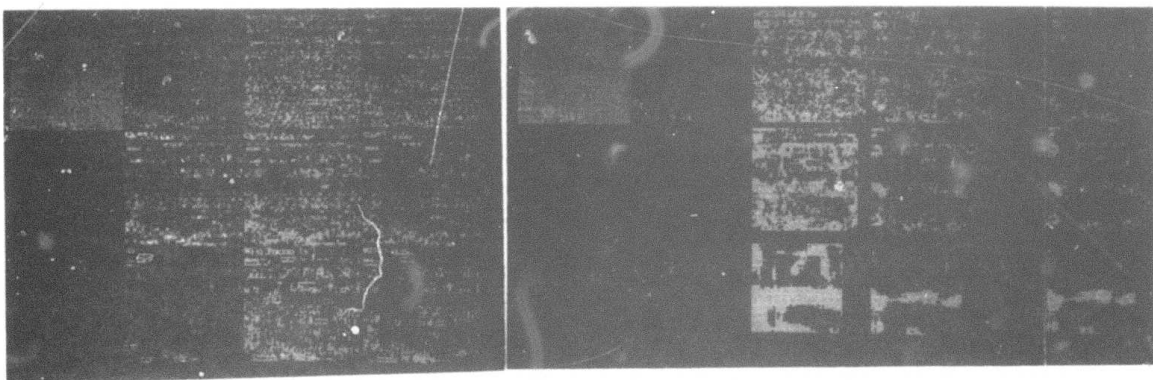

14N

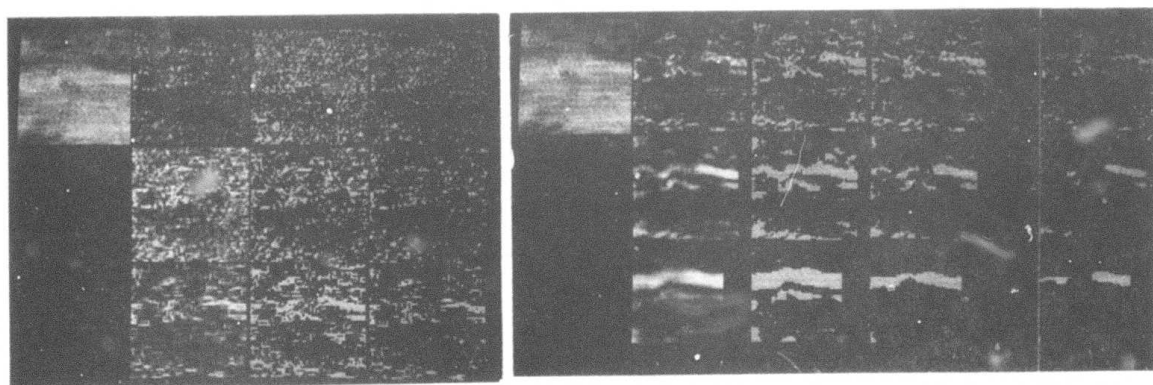

20N

Figure 21 (continued)

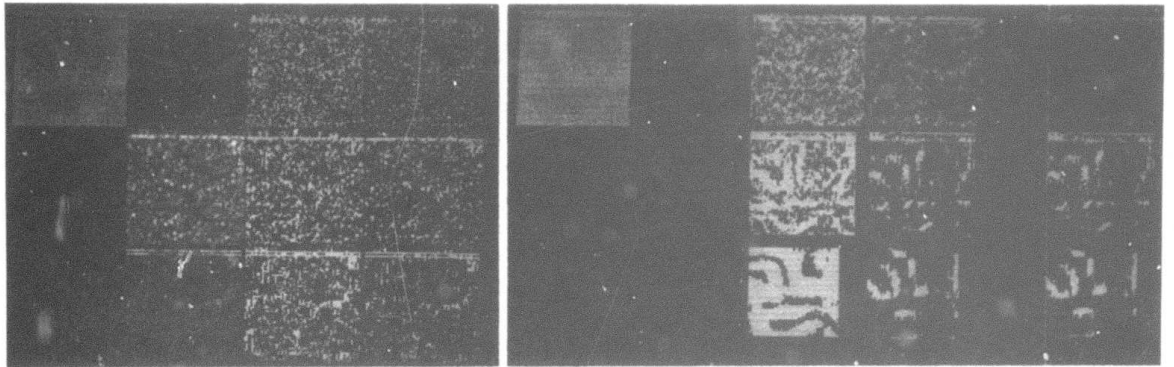

26N

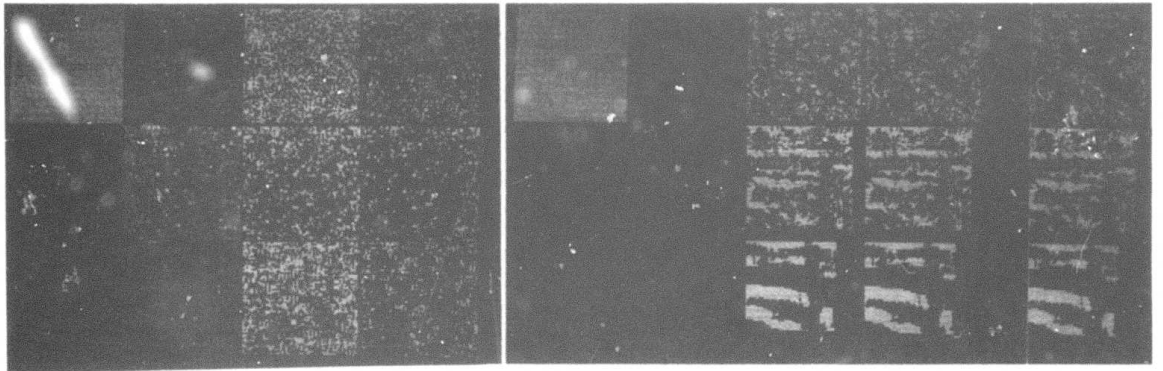

32N

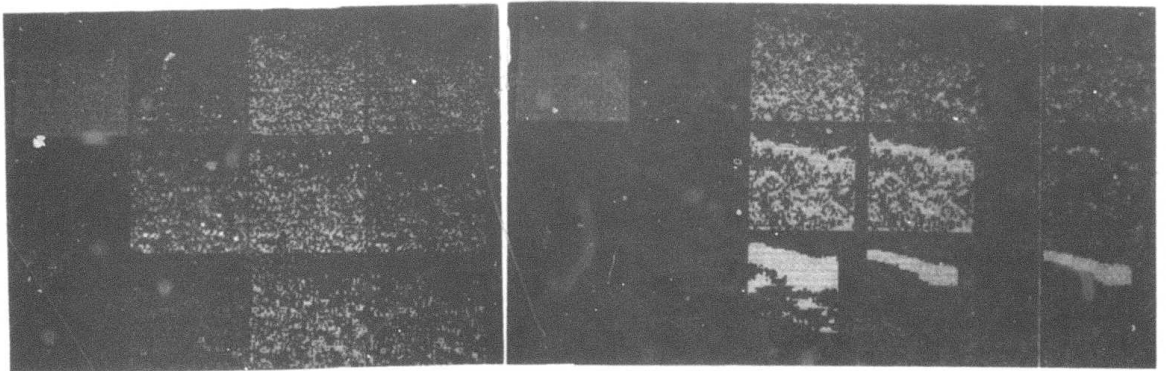

38N

Figure 21 (continued)

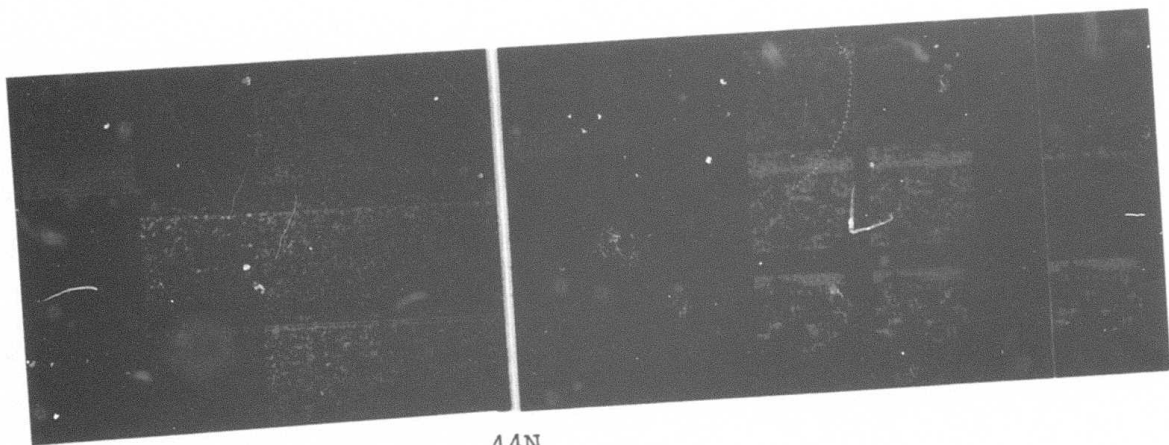

44N

Figure 21 (continued)

Laplacian: $|e - (a+b+c+d+f+g+h+i)/8|$, where the neighborhood of e is

```
a b c
d e f t
g h i u
v w
```

Roberts Gradient: $\max\{|a-e|, |b-d|\}$.

Three-by-three: $\max\{|a+b+c+g-h-i|, |a+d+g-c-f-i|\}$

2x2 Difference:

$1/4 * \max\{|d+e+g+h-f-t-i-u|, |b+c+e+f-h-i-v-w|\}$.

(In other words, the value corresponds to the maximum of the differences between 2x2 averages over adjacent pairs of horizontal and vertical neighborhoods.)

4x4 Difference: This is the same as the 2x2 difference except that averages are taken over 4x4 neighborhoods.

8x8 Difference: The same as the previous except that averages are taken over 8x8 neighborhoods.

In order to select high edge values, three percentiles were chosen -- 80%, 90% and 95%. Figure 21 also illustrates the masks consisting of points whose edge values were in the top 20%, 10% and 5%, respectively. The gray levels (in the original images) at these points were histogrammed and the means and modes tabulated (Table 3). The mean values were used as thresholds on the original images. Figure 22 shows the resulting thresholded images.

Table 3. Gray level statistics for points of high edge value based on 80th, 90th, and 95th percentiles for five edge operators. ("OP" codes represent in order: Laplacian, Roberts gradient, 3x3 gradient, 4x4 averages difference, 8x8 averages difference. IRN refers to the image reference number in the NVL data base.)

Table 3,

| OP | PIC | % | MEAN | MODE | ST DEV | % | MEAN | MODE | ST DEV | IRN |
|-----|------|----|------|------|--------|----|------|------|--------|-----|
| LAP | T5 | 00 | 25 | 29 | 0.38 | 90 | 20 | 29 | 10:00 | 3 |
| LAP | T5 | 00 | 23 | 27 | 0.62 | 90 | 24 | 27 | 10:00 | 6 |
| LAP | T117 | 00 | 24 | 20 | 0.14 | 90 | 25 | 27 | 10:39 | 16 |
| LAP | T121 | 00 | 24 | 25 | 0.27 | 90 | 25 | 25 | 11:38 | 28 |
| LAP | T125 | 00 | 24 | 25 | 0.59 | 90 | 24 | 25 | 11:03 | 34 |
| LAP | T131 | 00 | 25 | 24 | 0.22 | 90 | 26 | 24 | 09:57 | 35 |
| LAP | T135 | 00 | 21 | 21 | 0.98 | 90 | 21 | 23 | 06:34 | 39 |
| LAP | T140 | 00 | 21 | 29 | 0.72 | 90 | 26 | 29 | 06:54 | 42 |
| LAP | RI | 00 | 24 | 29 | 0.10 | 90 | 23 | 29 | 06:05 | 45 |
| LAP | RO | 00 | 23 | 20 | 0.71 | 90 | 24 | 26 | 06:49 | 49 |
| LAP | RB | 00 | 23 | 20 | 0.24 | 90 | 23 | 26 | 06:05 | 50 |
| LAP | RI19 | 00 | 24 | 20 | 0.18 | 90 | 28 | 29 | 05:02 | 52 |
| LAP | RI19 | 00 | 22 | 20 | 0.91 | 90 | 26 | 26 | 05:44 | 55 |
| LAP | RI17 | 00 | 22 | 17 | 0.64 | 90 | 24 | 25 | 05:17 | 24 |
| LAP | RI22 | 00 | 22 | 23 | 0.57 | 90 | 24 | 25 | 05:20 | 31 |
| LAP | RI24 | 00 | 22 | 23 | 0.65 | 90 | 23 | 25 | 05:48 | 48 |
| LAP | A4 | 00 | 22 | 23 | 0.09 | 90 | 23 | 23 | 05:24 | 57 |
| LAP | A5 | 00 | 24 | 23 | 0.97 | 90 | 24 | 26 | 05:48 | 55 |
| LAP | A11 | 00 | 24 | 23 | 0.35 | 90 | 24 | 24 | 06:24 | 24 |
| LAP | A13 | 00 | 24 | 20 | 0.17 | 90 | 24 | 24 | 06:44 | 44 |
| LAP | A14 | 00 | 22 | 24 | 0.75 | 90 | 22 | 24 | 06:38 | 44 |
| LAP | A10 | 00 | 22 | 24 | 0.10 | 90 | 22 | 24 | 06:24 | 44 |
| LAP | A20 | 00 | 22 | 24 | 0.71 | 90 | 22 | 24 | 06:38 | 44 |
| LAP | A22 | 00 | 22 | 23 | 0.54 | 90 | 22 | 23 | 06:44 | 44 |
| LAP | A26 | 00 | 22 | 23 | 0.74 | 90 | 22 | 23 | 06:59 | 44 |
| LAP | N2 | 00 | 21 | 23 | 0.40 | 90 | 21 | 23 | 07:15 | 40 |
| LAP | N6 | 00 | 21 | 23 | 0.51 | 90 | 21 | 23 | 07:35 | 40 |
| LAP | N14 | 00 | 22 | 23 | 0.44 | 90 | 22 | 23 | 08:00 | 40 |
| LAP | N20 | 00 | 22 | 23 | 0.37 | 90 | 22 | 23 | 08:06 | 40 |
| LAP | N22 | 00 | 22 | 23 | 0.81 | 90 | 22 | 23 | 08:55 | 40 |
| LAP | N22 | 00 | 22 | 23 | 0.15 | 90 | 22 | 23 | 09:48 | 40 |
| LAP | N23 | 00 | 22 | 23 | 0.53 | 90 | 22 | 23 | 10:14 | 40 |
| LAP | N23 | 00 | 22 | 23 | 0.15 | 90 | 22 | 23 | 10:58 | 40 |
| LAP | N23 | 00 | 22 | 23 | 0.49 | 90 | 22 | 23 | 11:45 | 40 |
| LAP | N23 | 00 | 22 | 23 | 0.08 | 90 | 22 | 23 | 11:57 | 40 |
| LAP | N23 | 00 | 22 | 23 | 0.11 | 90 | 22 | 23 | 11:57 | 40 |

| UP | PIC | % | MEAN | MODE | ST DEV | % | MEAN | MODE | ST DEV | IRN |
|-----|-----|----|------|------|--------|----|------|------|--------|-----|
| R0B | T5 | 80 | 25 | 20 | 8.10 | 90 | 25 | 26 | 9.67 | 3 |
| R0B | T9 | 80 | 22 | 19 | 7.47 | 90 | 27 | 17 | 10.67 | 9 |
| R0H | T14 | 80 | 26 | 21 | 9.56 | 90 | 30 | 23 | 10.66 | 16 |
| R0B | T17 | 80 | 24 | 22 | 9.73 | 90 | 25 | 22 | 11.67 | 28 |
| R0B | T21 | 80 | 23 | 21 | 9.77 | 90 | 27 | 22 | 11.04 | 34 |
| R0B | T24 | 80 | 26 | 21 | 9.39 | 90 | 27 | 22 | 11.20 | 57 |
| R0B | T30 | 80 | 20 | 22 | 9.39 | 90 | 21 | 22 | 11.57 | 36 |
| R0B | R1 | 80 | 24 | 25 | 7.32 | 90 | 25 | 22 | 11.57 | 24 |
| R0B | R3 | 80 | 23 | 22 | 7.57 | 90 | 27 | 22 | 11.53 | 34 |
| R0B | R8 | 80 | 27 | 22 | 9.77 | 90 | 23 | 22 | 11.53 | 48 |
| R0B | R10 | 80 | 25 | 22 | 9.80 | 90 | 25 | 22 | 11.69 | 57 |
| R0B | R13 | 80 | 23 | 22 | 9.20 | 90 | 25 | 22 | 11.91 | 22 |
| R0B | R17 | 80 | 23 | 21 | 9.45 | 90 | 27 | 22 | 12.47 | 77 |
| R0B | R22 | 80 | 23 | 21 | 9.55 | 90 | 23 | 22 | 12.91 | 44 |
| R0B | R24 | 80 | 22 | 22 | 9.73 | 90 | 23 | 22 | 13.47 | 77 |
| R0B | A1 | 80 | 24 | 22 | 9.91 | 90 | 23 | 22 | 13.49 | 44 |
| R0B | A4 | 80 | 24 | 22 | 9.44 | 90 | 23 | 22 | 13.83 | 44 |
| R0B | A5 | 80 | 24 | 21 | 9.63 | 90 | 23 | 22 | 14.23 | 44 |
| R0B | A13 | 80 | 21 | 22 | 9.11 | 90 | 23 | 22 | 14.83 | 48 |
| R0B | A14 | 80 | 23 | 22 | 10.08 | 90 | 23 | 22 | 15.83 | 48 |
| R0B | A10 | 80 | 22 | 21 | 9.35 | 90 | 22 | 22 | 16.83 | 48 |
| R0B | A22 | 80 | 22 | 21 | 9.05 | 90 | 22 | 22 | 17.66 | 48 |
| R0B | A20 | 80 | 20 | 22 | 9.63 | 90 | 22 | 22 | 18.66 | 48 |
| R0B | N2 | 80 | 20 | 22 | 7.64 | 90 | 22 | 22 | 19.66 | 40 |
| R0B | N6 | 80 | 21 | 22 | 9.67 | 90 | 22 | 22 | 20.66 | 40 |
| R0B | N14 | 80 | 21 | 22 | 9.62 | 90 | 22 | 22 | 21.66 | 40 |
| R0B | N20 | 80 | 21 | 22 | 9.68 | 90 | 22 | 22 | 22.66 | 40 |
| R0B | N22 | 80 | 22 | 22 | 9.44 | 90 | 22 | 22 | 23.66 | 40 |
| R0B | N28 | 80 | 22 | 22 | 9.41 | 90 | 22 | 22 | 24.66 | 40 |
| R0B | N34 | 80 | 22 | 22 | 9.46 | 90 | 22 | 22 | 25.66 | 40 |
| R0B | N44 | 80 | 21 | 22 | 9.41 | 90 | 22 | 22 | 26.66 | 40 |
| R0B | N50 | 80 | 21 | 22 | 9.41 | 90 | 22 | 22 | 27.66 | 40 |

| OP | PIC | MEAN | MODE | ST DEV | % | MEAN | MODE | ST DEV | % | MEAN | MODE | ST DEV | ST DFV | IRN |
|----|-----|------|------|--------|----|------|------|--------|----|------|------|--------|--------|-----|
| U | I3 | 29 | 29 | 0.91 | 90 | 33 | 30 | 7.70 | 95 | 34 | 33 | 7.11 | 3 | |
| U | I9 | 30 | 31 | 1.30 | 90 | 33 | 32 | 11.40 | 95 | 34 | 33 | 12.26 | 11 | |
| U | I17 | 33 | 32 | 1.01 | 90 | 33 | 32 | 10.28 | 95 | 34 | 33 | 11.70 | 16 | |
| U | I21 | 28 | 30 | 2.57 | 90 | 33 | 30 | 3.37 | 95 | 34 | 33 | 3.83 | 28 | |
| U | I25 | 28 | 30 | 3.31 | 90 | 33 | 30 | 1.17 | 95 | 34 | 33 | 1.43 | 34 | |
| U | I35 | 21 | 22 | 2.68 | 90 | 33 | 22 | 3.36 | 95 | 34 | 33 | 3.10 | 35 | |
| U | K1 | 21 | 19 | 2.77 | 90 | 33 | 18 | 2.16 | 95 | 34 | 33 | 2.89 | 37 | |
| U | K5 | 24 | 22 | 2.68 | 90 | 33 | 19 | 2.89 | 95 | 34 | 33 | 3.09 | 38 | |
| U | K6 | 24 | 23 | 2.94 | 90 | 33 | 20 | 2.06 | 95 | 34 | 33 | 2.47 | 39 | |
| U | K8 | 26 | 25 | 1.77 | 90 | 33 | 22 | 3.43 | 95 | 34 | 33 | 3.45 | 41 | |
| U | K9 | 26 | 24 | 2.14 | 90 | 33 | 23 | 2.69 | 95 | 34 | 33 | 2.47 | 42 | |
| U | R5 | 23 | 24 | 1.47 | 90 | 33 | 24 | 2.99 | 95 | 34 | 33 | 3.35 | 43 | |
| U | R13 | 24 | 24 | 3.63 | 90 | 33 | 24 | 3.43 | 95 | 34 | 33 | 3.75 | 44 | |
| U | R15 | 24 | 24 | 2.79 | 90 | 33 | 24 | 2.69 | 95 | 34 | 33 | 2.75 | 45 | |
| U | R17 | 24 | 24 | 2.79 | 90 | 33 | 24 | 2.69 | 95 | 34 | 33 | 2.75 | 46 | |
| U | R24 | 22 | 22 | 4.78 | 90 | 33 | 24 | 3.91 | 95 | 34 | 33 | 3.24 | 47 | |
| U | K21 | 22 | 21 | 2.25 | 90 | 33 | 21 | 2.50 | 95 | 34 | 33 | 2.24 | 48 | |
| U | A4 | 22 | 21 | 1.79 | 90 | 33 | 21 | 1.19 | 95 | 34 | 33 | 1.24 | 49 | |
| U | A5 | 22 | 21 | 2.79 | 90 | 33 | 21 | 2.50 | 95 | 34 | 33 | 2.24 | 50 | |
| U | A13 | 25 | 25 | 2.79 | 90 | 33 | 25 | 2.50 | 95 | 34 | 33 | 2.24 | 51 | |
| U | A14 | 25 | 25 | 2.65 | 90 | 33 | 25 | 2.46 | 95 | 34 | 33 | 2.24 | 52 | |
| U | A16 | 27 | 27 | 2.08 | 90 | 33 | 27 | 1.79 | 95 | 34 | 33 | 1.70 | 53 | |
| U | A20 | 27 | 27 | 2.96 | 90 | 33 | 27 | 2.03 | 95 | 34 | 33 | 1.97 | 54 | |
| U | A22 | 22 | 22 | 2.03 | 90 | 33 | 22 | 1.79 | 95 | 34 | 33 | 1.70 | 55 | |
| U | A2 | 22 | 22 | 2.84 | 90 | 33 | 22 | 2.44 | 95 | 34 | 33 | 2.24 | 56 | |
| U | M5 | 29 | 29 | 2.59 | 90 | 33 | 29 | 2.03 | 95 | 34 | 33 | 1.97 | 57 | |
| U | M14 | 19 | 19 | 2.59 | 90 | 33 | 19 | 2.03 | 95 | 34 | 33 | 1.97 | 58 | |
| U | M20 | 19 | 19 | 2.59 | 90 | 33 | 19 | 2.03 | 95 | 34 | 33 | 1.97 | 59 | |
| U | M22 | 19 | 19 | 2.59 | 90 | 33 | 19 | 2.03 | 95 | 34 | 33 | 1.97 | 60 | |
| U | M32 | 19 | 19 | 2.59 | 90 | 33 | 19 | 2.03 | 95 | 34 | 33 | 1.97 | 61 | |
| U | M34 | 19 | 19 | 2.59 | 90 | 33 | 19 | 2.03 | 95 | 34 | 33 | 1.97 | 62 | |
| U | M35 | 19 | 19 | 2.59 | 90 | 33 | 19 | 2.03 | 95 | 34 | 33 | 1.97 | 63 | |
| U | M38 | 19 | 19 | 2.59 | 90 | 33 | 19 | 2.03 | 95 | 34 | 33 | 1.97 | 64 | |
| U | M40 | 19 | 19 | 2.59 | 90 | 33 | 19 | 2.03 | 95 | 34 | 33 | 1.97 | 65 | |

Figure 22. Thresholded images, using as threshold the mean gray level of the points in the 80th edge value percentile, for the following edge detectors:

| | |
|---------------------|-------------------|
| Laplacian | 2x2 difference |
| Roberts gradient | 4x4 difference |
| 3x3 gradient | 8x8 difference |

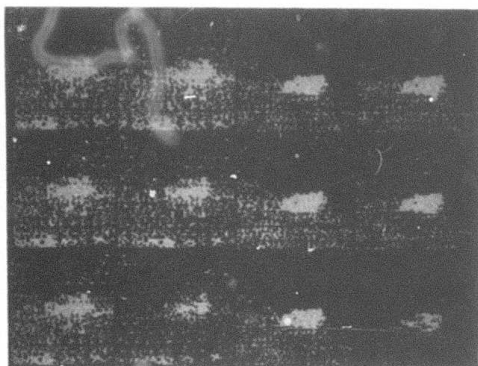

3T

6T

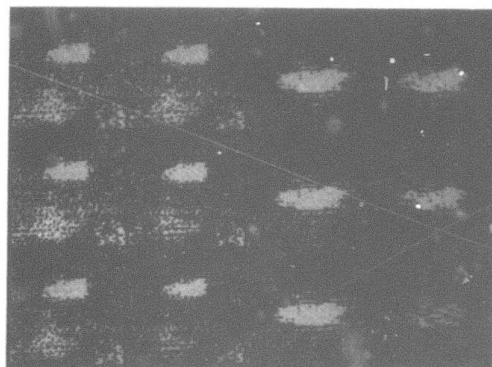

11T

16T

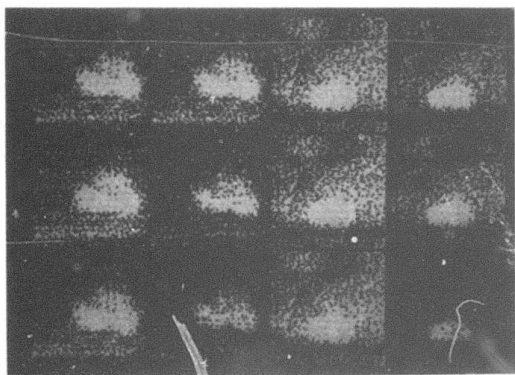

22T

28T

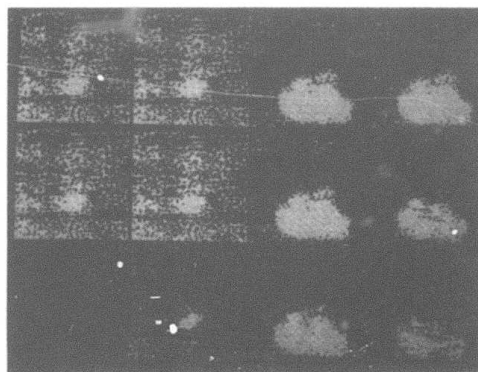

34T

45T

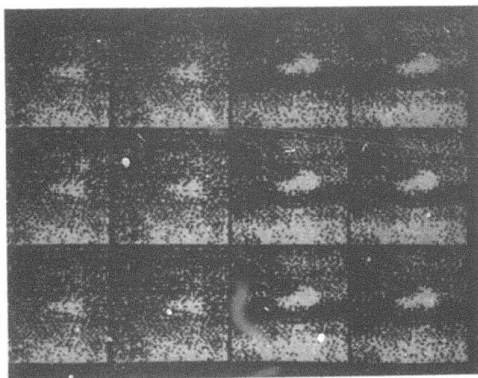

3R

6R

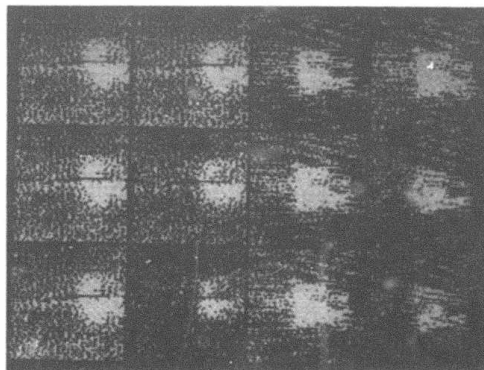

22R

24R

Figure 22 (continued)

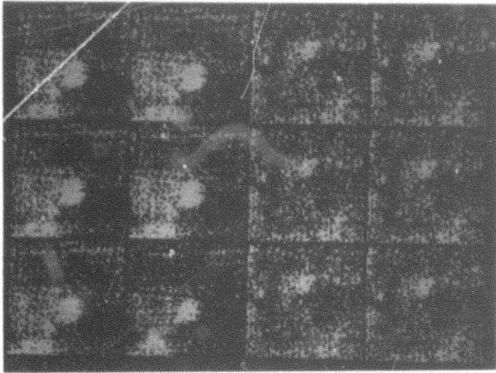

31R

34R

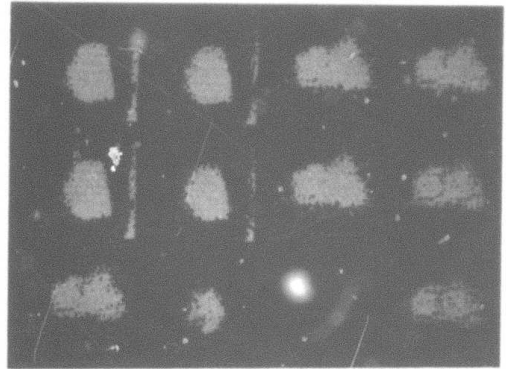

47R

48R

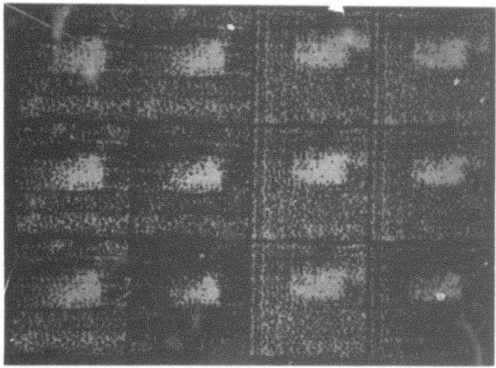

21A

24A

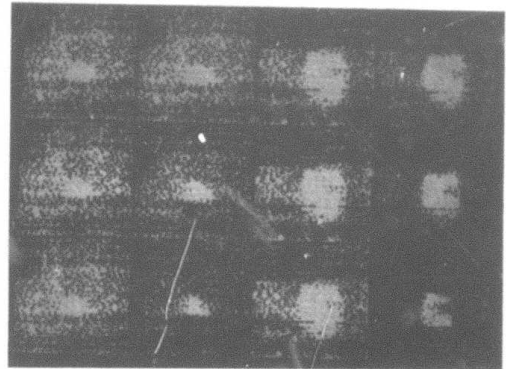

27A

37A

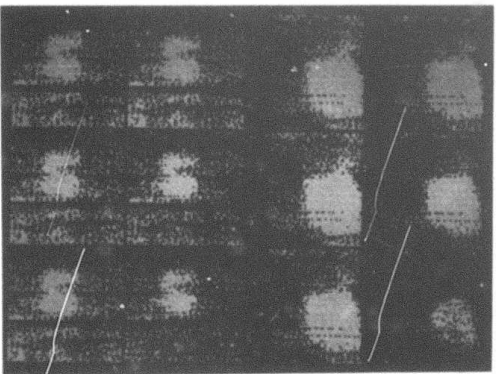

42A

44A

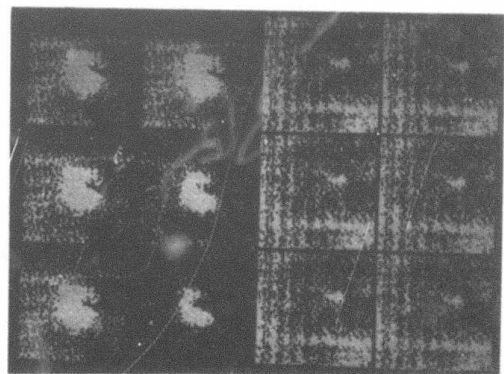

46A

52A

Figure 22 (continued)

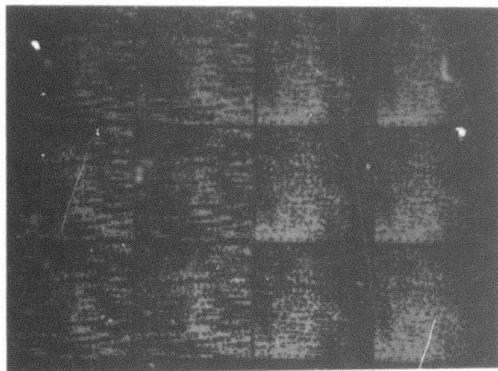

2N

8N

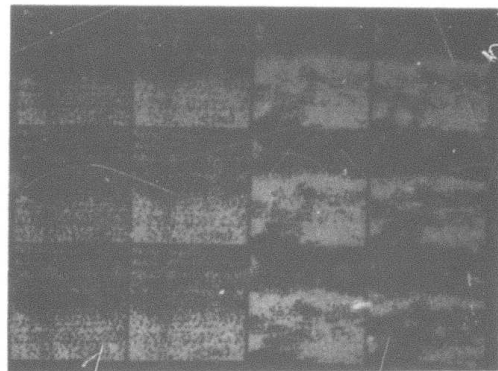

14N

20N

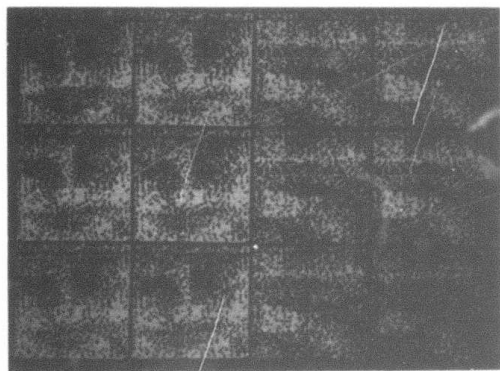

26N

32N

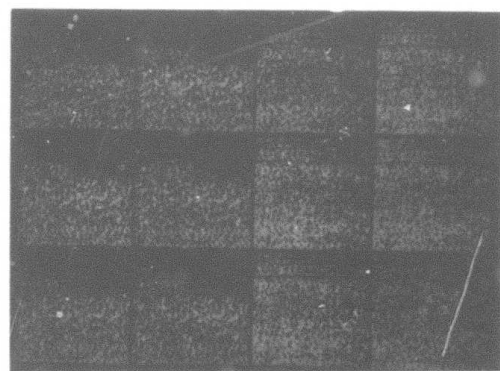

38N

44N

Figure 22 (continued)

Discussion

A number of parameters were introduced in this study, including the choice of edge operator, and the percentile cutoff. The Laplacian gave poor results due to the "rampiness" of the edges. The gradients produced reasonable edge masks but predicted different thresholds (i.e., different means of high edge value gray levels). The 4x4 operator produced good thresholds overall. This may be explained by noting that the ramp width as determined from the Roberts gradient was approximately 3. Thus operators based on 3x3 neighborhoods or smaller could not span the ramp and give accurate gradient values. The 4x4 difference, on the other hand, does span the ramp edge more effectively. If the neighborhood is too big, as in the 8x8 difference, the edge operator will be biased in favor of the background (since the object shape is usually convex) and will on occasion span the whole object (thus decreasing its response at the actual edge).

The choice of a percentile cutoff for the edge values is much more difficult to assess. Clearly, if an image contains no object then no percentile should be chosen since the operator is responding only to noise. The use of a cutoff assumes that the highest edge values will correspond to object/background edges rather than to noise. This is valid in the case of the difference of averages operators, since these operators will not respond as well to local noise as they do to object edges. The cutoff should therefore be at the edge value likely to separate out almost all of the object edge values. Clearly, the optimal value depends on

target size. However, in practice, the 80th percentile of the 4x4 operator produced a reliable sample which contained somewhat more background edge points than object points, resulting in a low threshold; but this was deemed acceptable because of the subsequent noise cleaning process which tended to smooth tattered object boundaries.

Overall, this automatic thresholding technique provided reasonable thresholds and produced good segmentations for later processing. Computationally, the procedure involved three passes over the input image and one pass over the intermediate edge image. During the first image pass, the edge operator is applied and an edge image created. Simultaneously, an edge value histogram is computed. The 80th percentile value is then compared. During the second pass, both the input image and the edge image are read. The gray level values of those edge points whose edge values are at or above the 80% cutoff value are histogrammed. The mean of the histogrammed points serves as the threshold for the third pass. In a dynamic environment, producing thirty images per second, it should be possible to apply the three different passes in pipeline fashion to three consecutive images (assuming that the gray level statistics remain stable over the period necessary to process three images). The storage requirements would be reduced to the number of lines necessary to compute the operator. This dynamic approach will be tested with a real-time sequence of images during the next quarter.

An alternative computational approach determines the threshold in a single pass over the input image, at the cost of storing a 2-D histogram within an array of counters. If the gray level value at the current image point is i and the edge operator is j , then the (i,j) th counter is incremented. Now, high edge values correspond to high-index rows in the 2-D histogram array. The row sums form the edge value histogram, whose 80th percentile is then chosen. Next, the column sums are formed for all rows at or above the 80% cutoff. These sums constitute the gray level histogram for high edge values. The mean of this histogram is the desired threshold.

E1. Edge Reinforcement Prior to Noise Cleaning

Noise cleaning operations, in particular, parallel shrink/expand algorithms, will delete points from ragged edges of objects. The result is that an object will be displayed with fewer points than were proposed by the thresholding step. One way of avoiding this is to choose a slightly more generous threshold, thus adding in more background points which presumably are later rejected during noise cleaning. Unfortunately, this strategy adds in noise points all over the image. A technique which adds only points at or near the boundary of objects is preferable. Such points generally have high gradient value. Section B suggested the following technique: compute the threshold automatically as described in Section D, and use a combined (gray level, gradient value) threshold to include high gradient value points which don't quite exceed the gray level threshold value. In practice, this may be implemented using the 2-D (gray level, gradient) histogram; such histograms are shown in Figure 23. On such a histogram, a vertical line corresponds to a gray level threshold, while an oblique line corresponds to a combined (gray level, gradient value) threshold. Image points whose (gray level, gradient value) pair lies to the left of BC are considered to be above threshold. Figure 24 illustrates this for several values of θ . Note that the effect of varying θ is mainly the accretion or loss of edge points. Clearly, the implementation of a combined threshold can be accomplished in the single

Figure 23. Two-dimensional (gray level, gradient) histograms. The displayed histogram value at row R and column C is the (log scaled) number of image points which have edge value R and gray level C.

Key: H_x denotes the two-dimensional histogram for edge detector x.

| <u>Edge detector</u> | <u>Denoted by subscript</u> |
|----------------------|-----------------------------|
| Laplacian | L |
| Roberts gradient | R |
| 3x3 gradient | 3 |
| 2x2 difference | 2 |
| 4x4 difference | 4 |
| 8x8 difference | 8 |

Original image

| | | | |
|---|-------|---|-------|
| L | H_L | 2 | H_2 |
| R | H_R | 4 | H_4 |
| 3 | H_3 | 8 | H_8 |

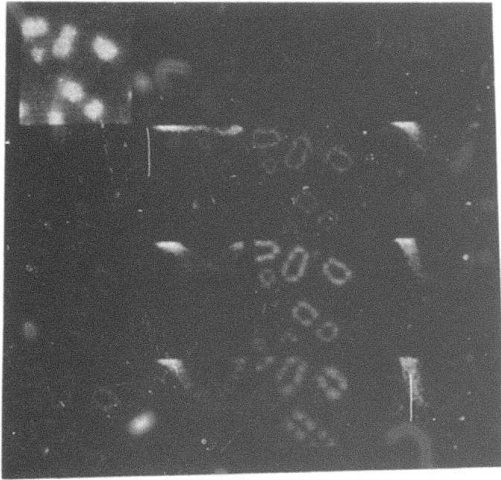

Chromosome

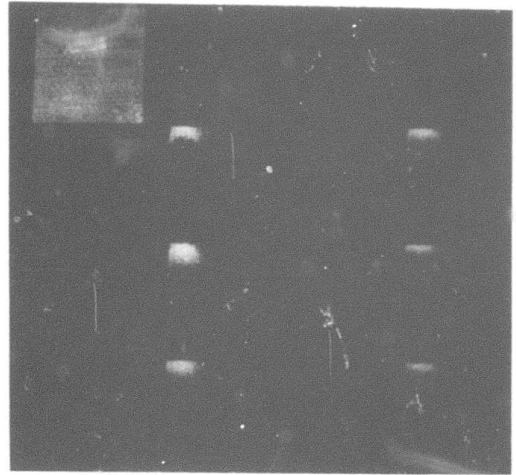

11T

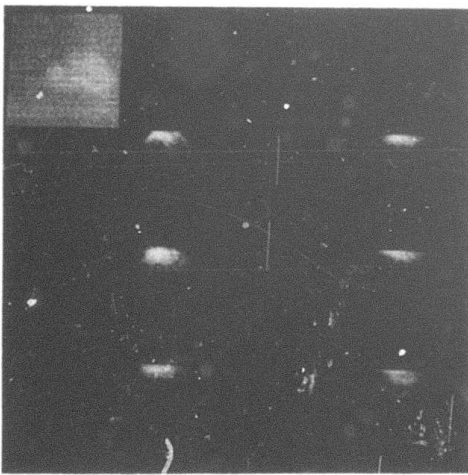

22T

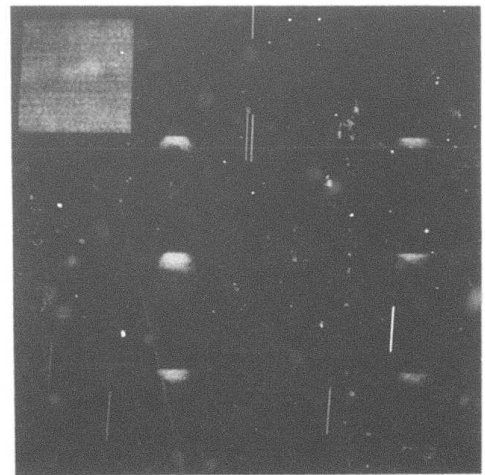

6R

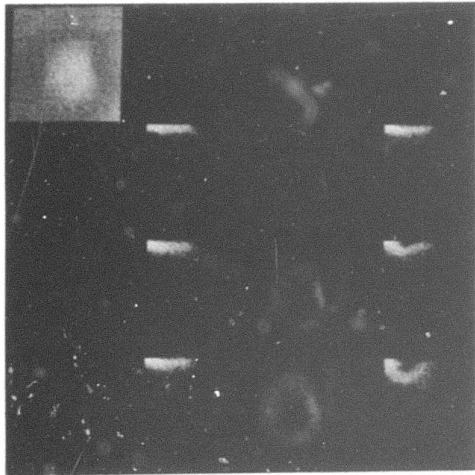

47R

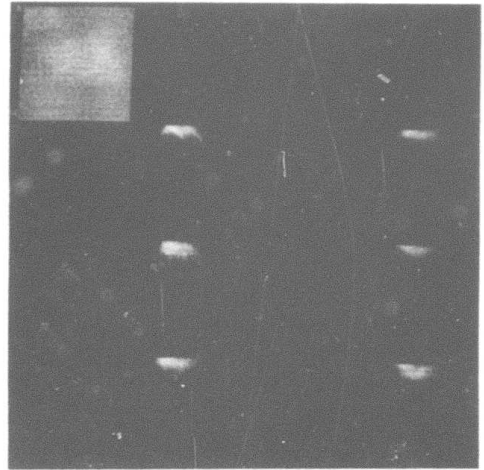

48R

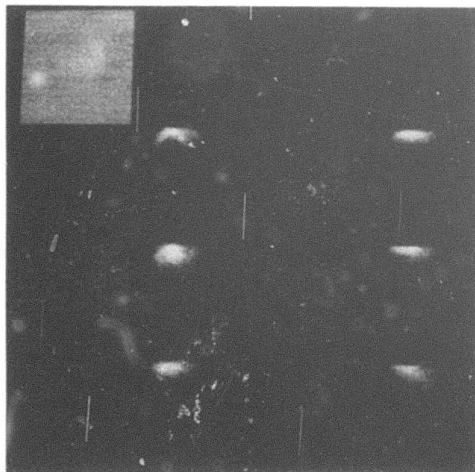

21A

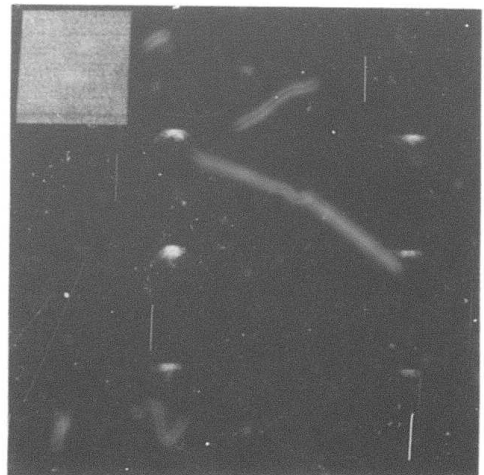

27A

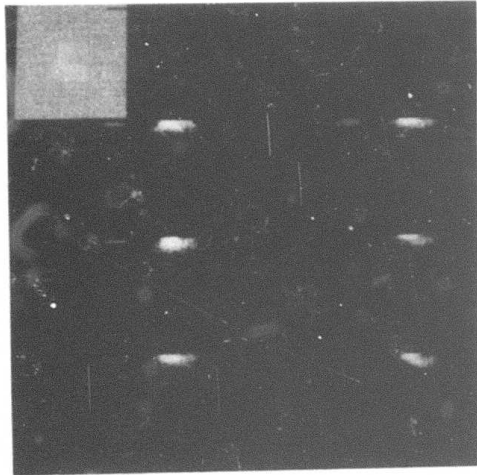

46A

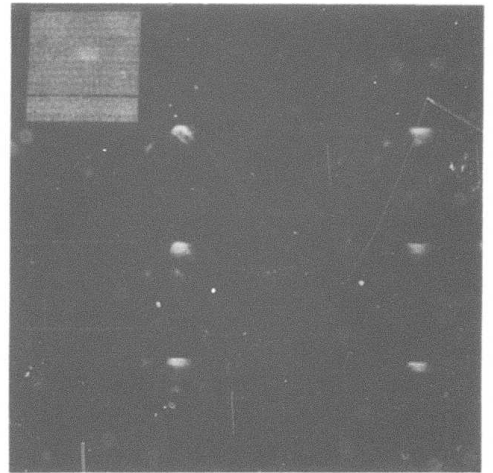

58A

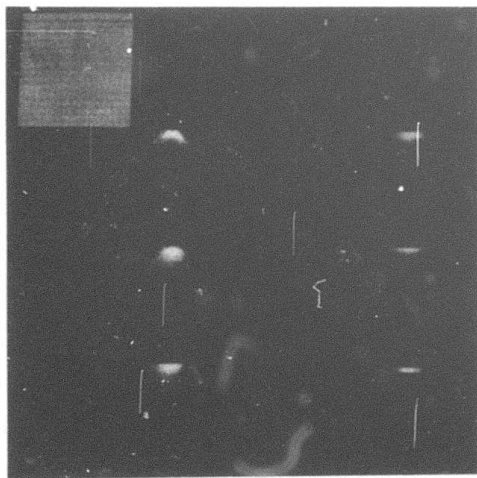

26N

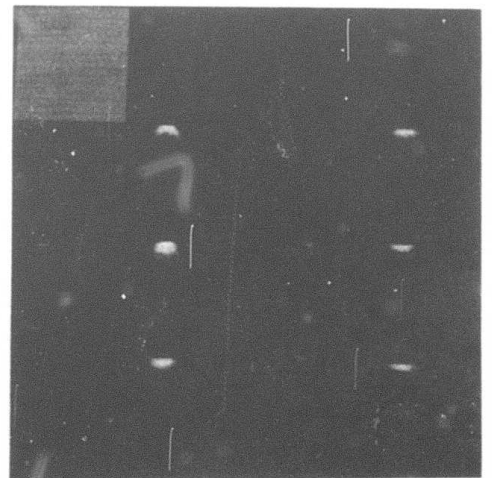

50N

Figure 23 (continued)

Figure 24. Thresholding using combined (gray level gradient) thresholds for the following values of θ .

| | |
|------|-----|
| -30° | 10° |
| -20° | 20° |
| -10° | 30° |
| 0° | |

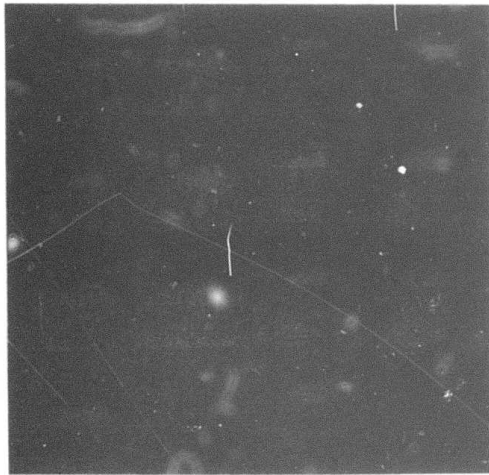

3T

11T

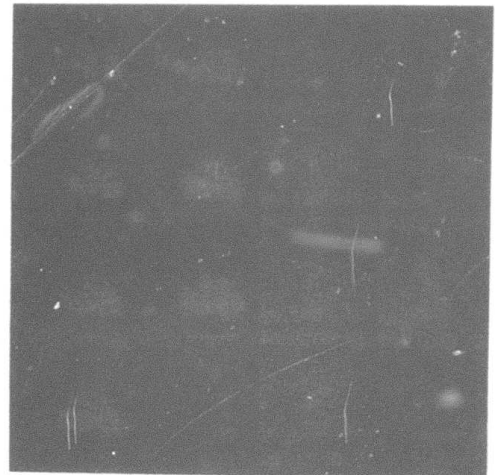

22T

34T

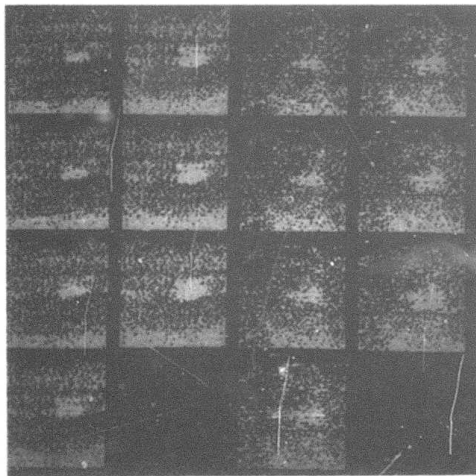

52T

3R

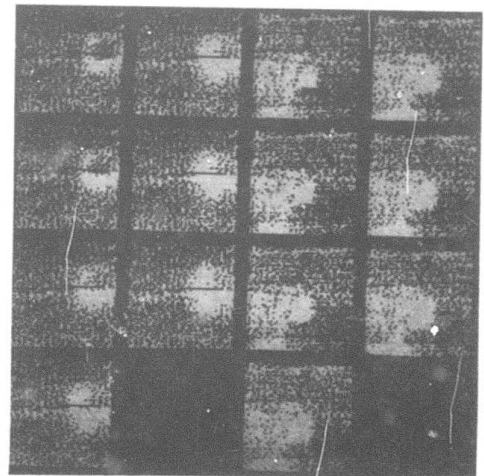

22R

31R

Figure 24 (continued)

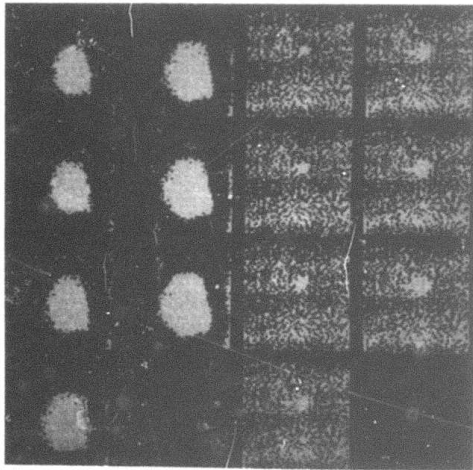

47R

55R

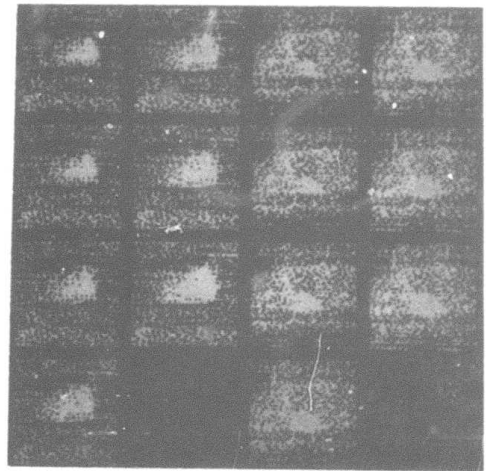

21A

27A



42A

46A

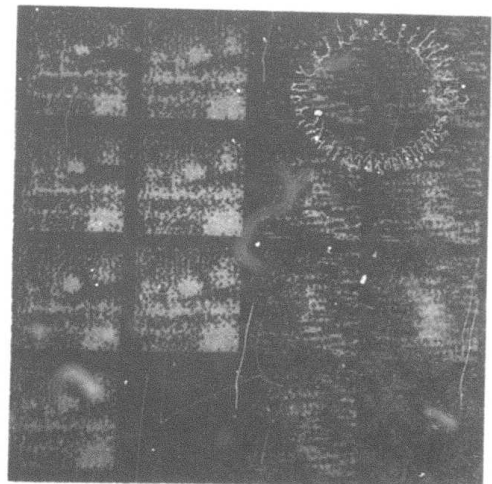

54A

2N

Figure 24 (continued)

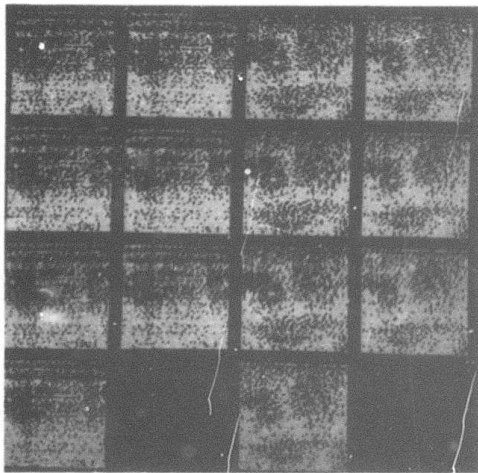

14N

26N

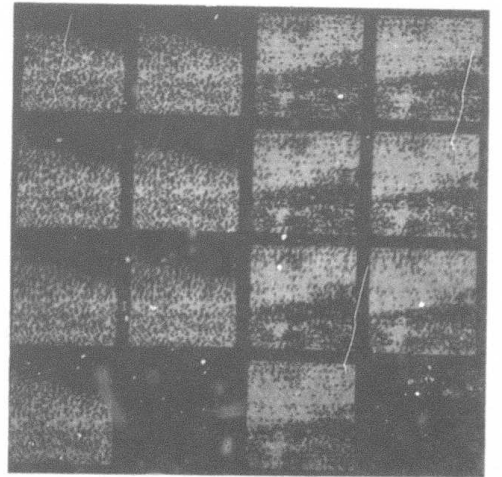

38N

50N

Figure 24 (continued)

thresholding pass. Further study of the model is needed to predict the appropriate value of θ for this type of thresholding procedure.

E2. Noise Cleaning by Averaging

The images in the data set are oversampled at a ratio of over 2:1 for the purpose of scaling the horizontal and vertical axes. The processed windows, however, were sampled down 2 to 1. The resulting windows exhibit moderate to severe high frequency noise. An effort was made to reduce this noise by producing windows based on 2x2 averaging rather than sampling. Thus, instead of discarding every other row and column, each pixel in the sampled image was the average over a (disjoint) 2x2 neighborhood in the original image. The results (Figure 25) show that a smooth, less noisy image was produced and that row dropouts were partially eliminated. However, the images seemed to have less contrast. Further experiments will determine if averaged windows should replace the sampled windows.

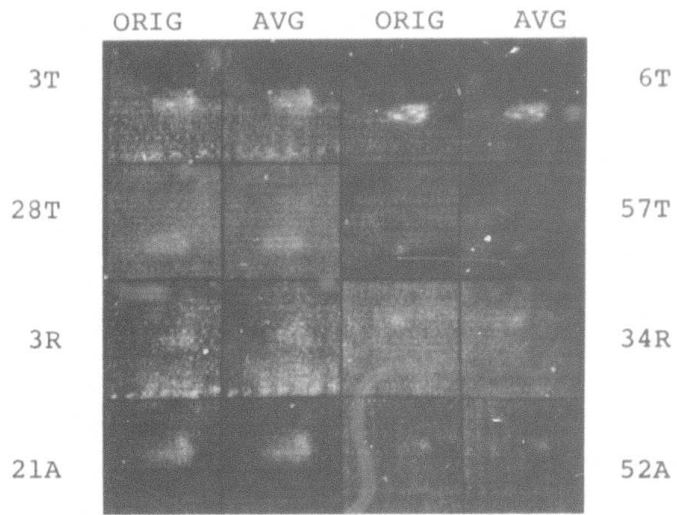

25a.

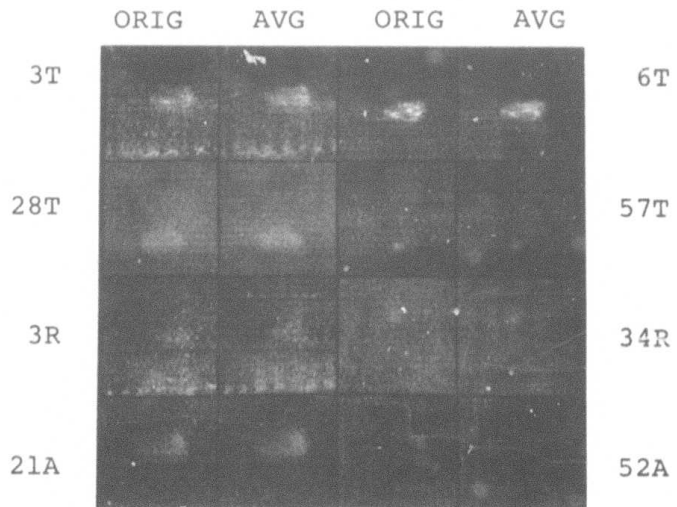

25b.

Figure 25. Sampling vs. averaging in target windows.
 a. The computed average using truncation.
 b. Same, using rounding.

E3. Noise Region Filtering by Simultaneous Local Operations

The result of thresholding a new (unsmoothed) image is a binary valued image with object points identified (nominally) by the value 1 and background points by the value 0. In general, one often obtains isolated points or small regions corresponding to spurious identifications in both the background and object regions (see Figure 22). Such regions, which will be called noise regions, are recognizable by their small size and their isolation, especially since it has been postulated that object regions are compact. Note that these noise regions are artifacts of the thresholding and may not be readily visible in the original image.

One method of eliminating noise regions is to preprocess the image by smoothing. Preprocessing algorithms based on blurring and median filtering will be studied more extensively in the next quarter. Another approach is to postprocess the thresholded image to delete the noise regions. This section discusses postprocessing techniques which eliminate small and/or non-compact regions from a thresholded image.

The method which was investigated consists of multiple applications of two processes -- "shrink" and "expand" -- for example, two shrinks followed by two expands. The purpose of the sequence of shrinks is to shrink objects in a uniform manner so that small or insubstantial objects disappear entirely. The sequence of expands is meant to

regrow the remaining shrunken objects to their original size. The result of the shrinks/expands is the elimination of small regions (presumed to be noise regions).

Each shrink or expand requires the simultaneous or "parallel" application of a local replacement rule at every point of the thresholded image. This means that all transform decisions are made on untransformed data, as distinguished from the sequential application of the transformation rule in a raster fashion with transformed point values replacing the original values as they are computed.

The form of the shrink rule is as follows: Rewrite each 1 as 0 if any (at least one) of its neighbors is already 0. Zero values are unchanged. (The 4-neighbor case treats, as neighbors, points horizontally or vertically adjacent to the given point; the 8-neighbor case includes the points diagonally adjacent as well.) Such a rule decreases the number of 1's in the thresholded image; thus, the image "shrinks". The rule can be interpreted as eliminating all 1's adjacent to 0's. In fact, only 1's surrounded by 1's will survive a shrink. Two shrinks applied in succession will eliminate all 1's at a distance of two or fewer raster units (city block or chessboard distance) from the nearest 0. The number of successive shrinks determines the minimum diameter of a region for it to survive; e.g., one shrink eliminates all objects with diameter two or less; two shrinks eliminate objects with diameters of four or less.

The expand rule is similar to the shrink rule: rewrite a 0 as a 1 if any of its neighbors are 1's, but leave 1's unchanged. Thus points adjacent to 1's become 1's, thereby increasing the number of 1's. If we wish to restore objects (that are not eliminated) to about their original sizes, t shrinks should be followed by t expands. Such a shrink/expand sequence produces an image whose 1's correspond to (a subset of the) 1's in the untransformed binary image. Thus, for example, isolated 1's are eliminated, and objects joined by narrow necks of 1's may become disconnected. Also, thin protrusions from a region of 1's will disappear. Figure 26 illustrates the shrink/expand algorithm for both the 4 and 8 neighbor cases and $t = 1, 2, 3$ (the numbers of shrinks and expands used). Figure 27 shows the effect that the choice of edge operator in threshold selection has on the subsequent noise cleaning.

The shrink rule as formulated was unsatisfactory because it tended to delete too much; it tended to produce regions all of the same shape (diamond-shaped); and it did not fill in pinholes. A generalization of the shrink rule was formulated as follows: delete a 1 if at least k of its neighbors are 0's (zeros remain unchanged). The original shrink rule corresponds now to $k = 1$. The generalized shrink is more conservative in that if $k > 1$, it takes more zero evidence to convert a 1 to 0. The generalized expand is analogously defined: Rewrite a 0 as 1 if it has at least k 1's as neighbors (ones remain unchanged). Note

Figure 26. Effects of iterating SHRINK/EXPANDS (S/E's).

- a. Original images - each column is a single image thresholded at four different values.
- b. 4-neighbor rule - one S/E
- c. 4-neighbor rule - two S/E's
- d. 4-neighbor rule - three S/E's
- e. 8-neighbor rule - one S/E
- f. 8-neighbor rule - two S/E's
- g. 8-neighbor rule - three S/E's

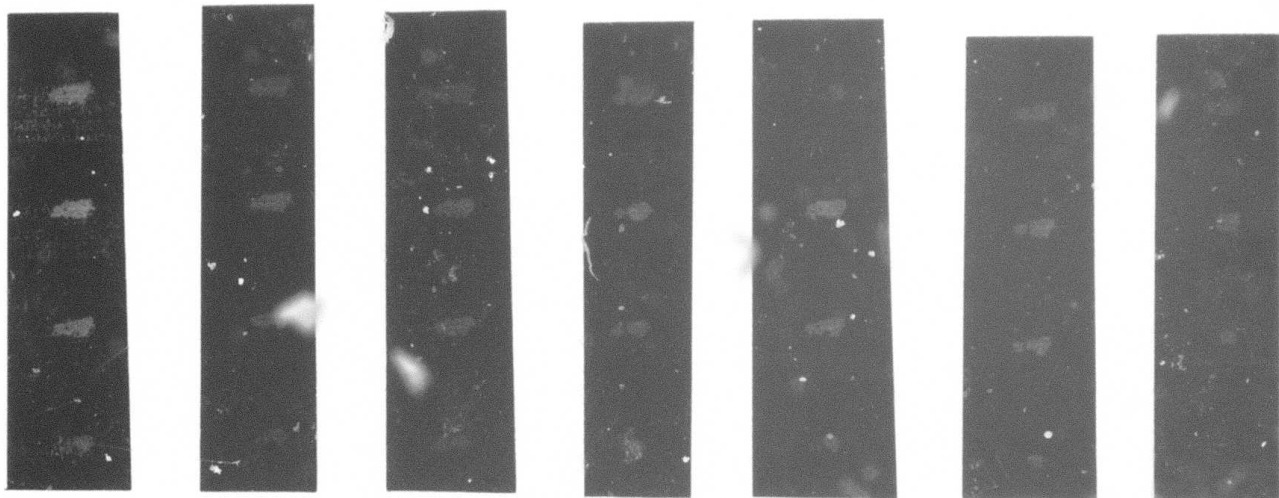

6T a. b. c. d. e. f. g.

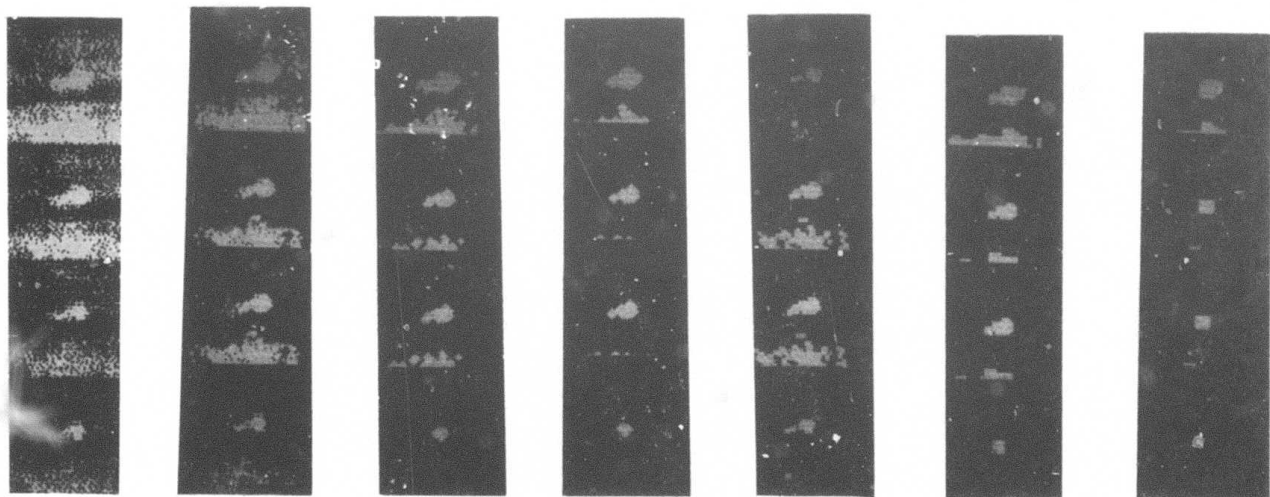

6R a. b. c. d. e. f. g.

Figure 26 (continued)

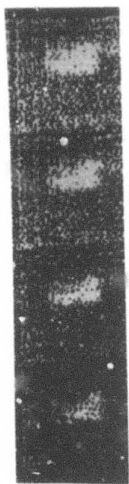

24A a.

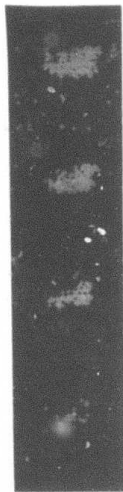

b.



c.



d.



e.

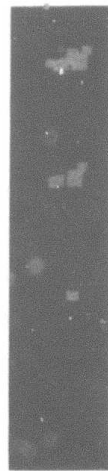

f.



g.

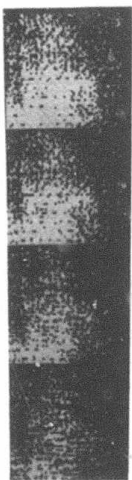

8N a.



b.

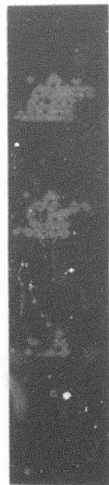

c.



d.

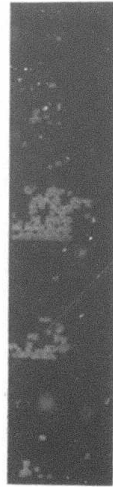

e.



f.



g.

Figure 26 (continued)

Figure 27. SHRINK/EXPAND: comparison of edge detection operators ($\tau=1$, $t=2$, 4-neighbor rule).

Key:

| | |
|------------------|----------------|
| Laplacian | 2x2 difference |
| Roberts gradient | 4x4 difference |
| 3x3 gradient | 8x8 difference |

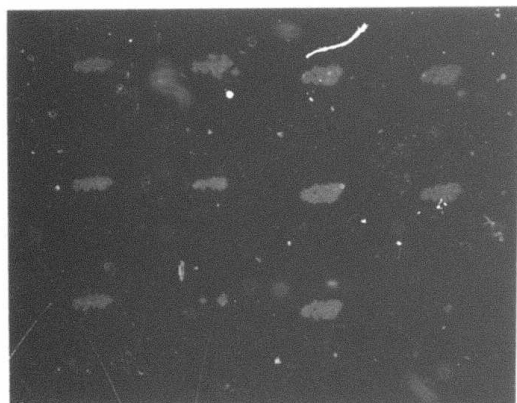

3T

6T

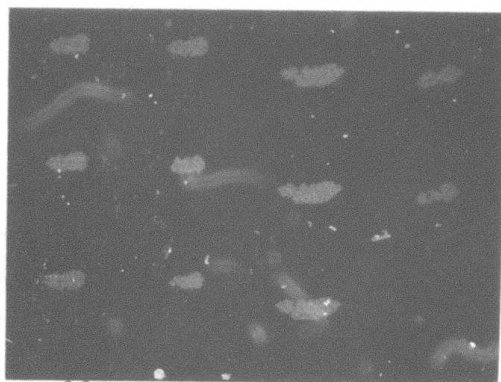

11T

16T

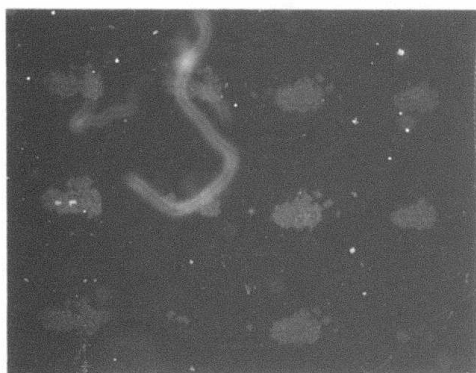

22T

28T

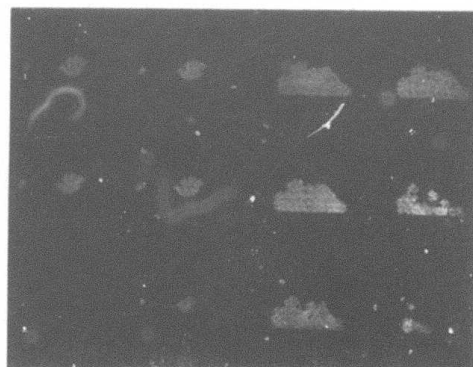

34T

45T

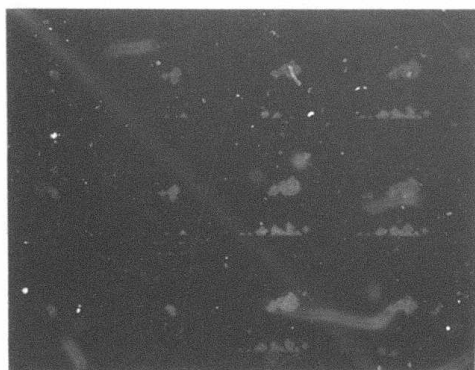

3R

6R

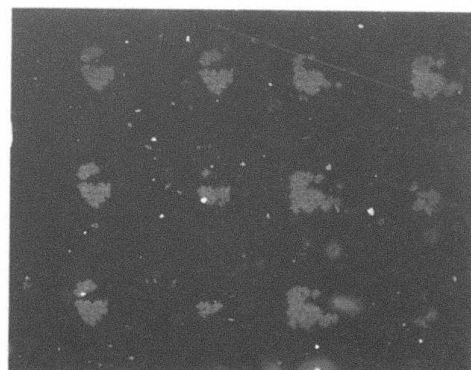

22R

24R

Figure 27 (continued)

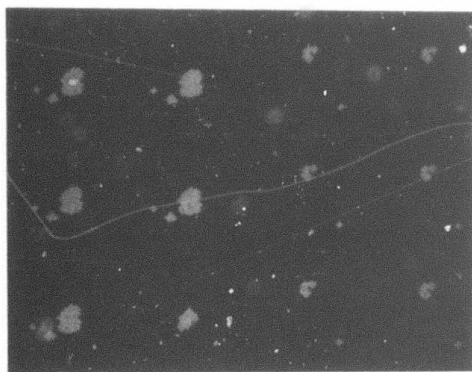

31R

34R

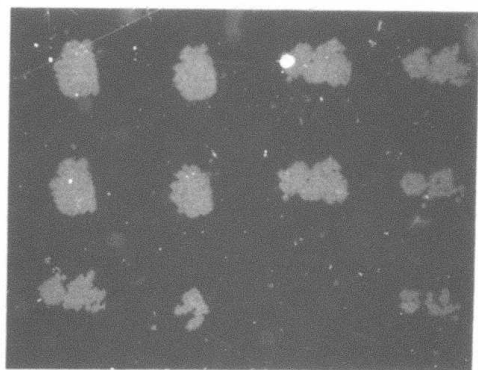

47R

48R

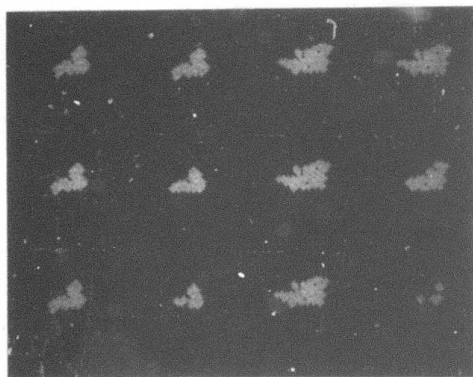

21A

24A

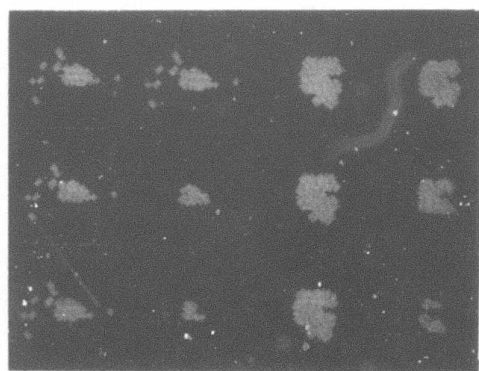

27A

37A

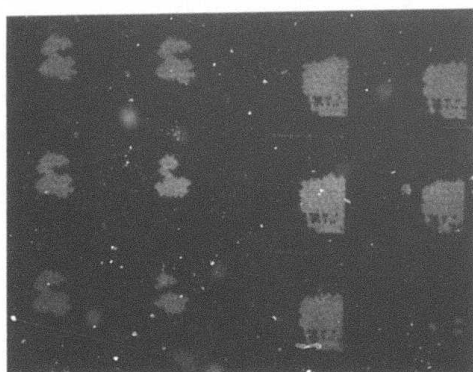

42A

44A

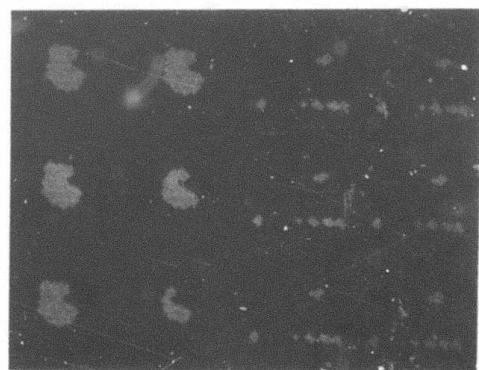

46A

52A

Figure 27 (continued)

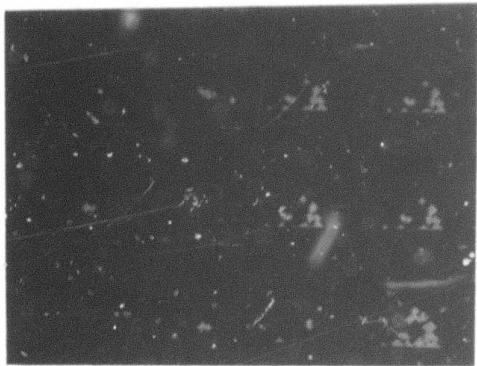

2N

8N

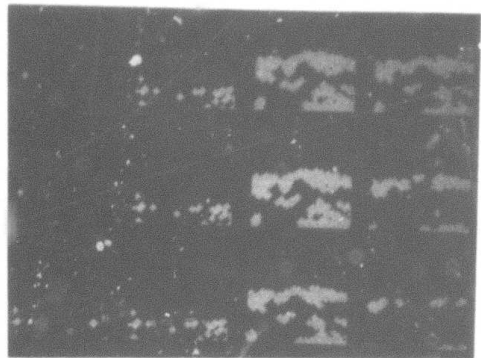

14N

20N

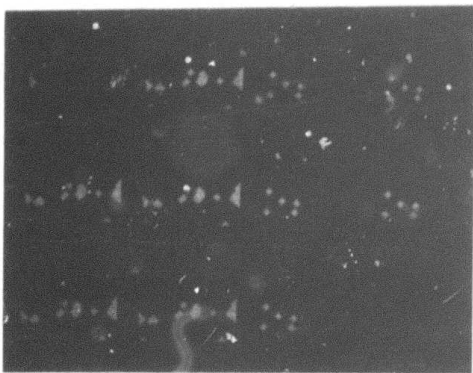

26N

32N

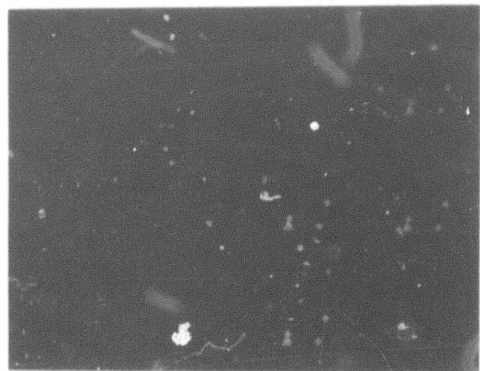

38N

44N

Figure 27 (continued)

that for increased k , the generalized expand rule is not quite as generous in providing new 1 values. However, it does fill pinholes in sufficiently large regions. Figure 28 provides a comparison for $t = 1, 2$ and $k = 1, 2, 3$. Figure 29 presents a further comparison based on the 4×4 edge operator used in threshold selection. It appears from these examples and from Figure 26 that the shrink/expand rule with $t = 2$ and $k = 3$ applied to each image point and its 8-neighbors provides efficient noise cleaning with most noise regions eliminated, pinholes filled, and only a modest amount of target shape distortion.

**Figure 28. Leniency in SHRINK/EXPAND definitions
for windows thresholded by two methods.**

- a. 4-neighbor rule, one S/E, $k=1,2,3$
- b. 8-neighbor rule, one S/E, $k=1,2,3$
- c. 4-neighbor rule, two S/E's, $k=1,2,3$
- d. 8-neighbor rule, two S/E's, $k=1,2,3$

ORIG k=1 k=2 k=3

3T
4x4
DIFF

8x8
DIFF

31R
4x4
DIFT

8x8
DIFF

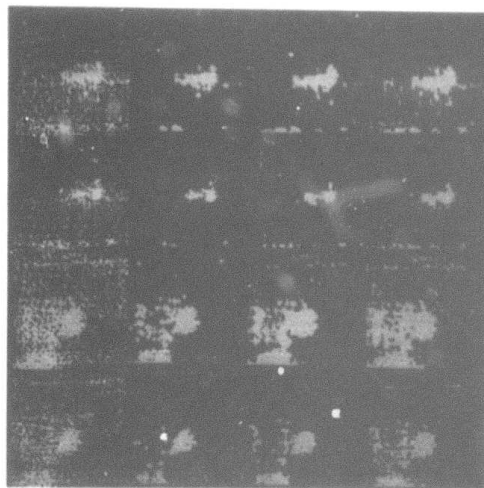

28a.

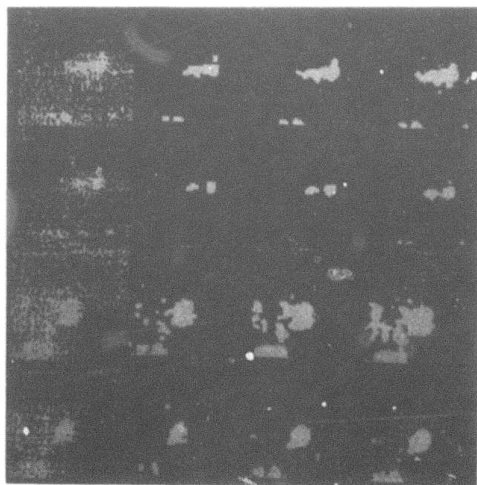

28b.

Figure 28 (continued)

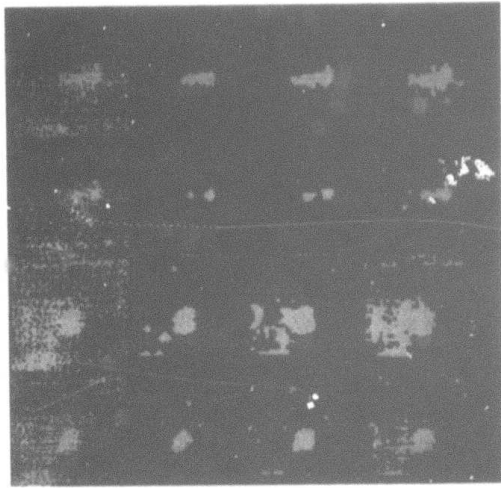

28c.

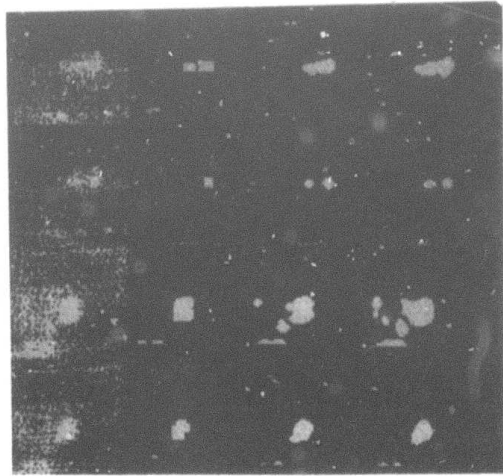

28d.

Figure 28 (continued)

Figure 29. SHRINK/EXPAND of thresholded images based on four edge operators (ROB, 3x3, 4x4 DIFF, 8x8 DIFF) and $k = 1, 2, 3$.

| <u>Key:</u> | <u>Gradient</u> | <u>Thresholded image</u> | <u>S/E,k=1</u> | <u>S/E,k=2</u> | <u>S/E,k=3</u> |
|-------------|-----------------|------------------------------|----------------|----------------|----------------|
| | Roberts | | | | |
| | 3x3 | | | | |
| | 4x4 | | | | |
| | 8x8 | | | | |



3T

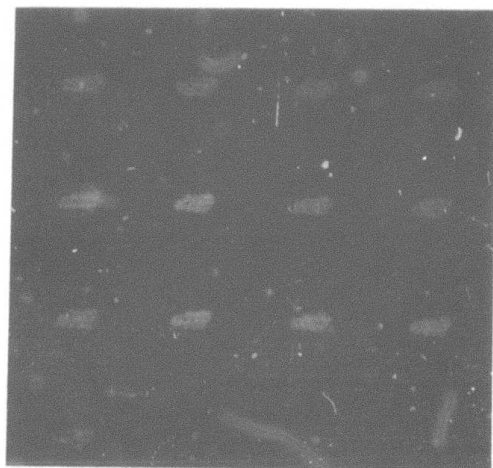

6T

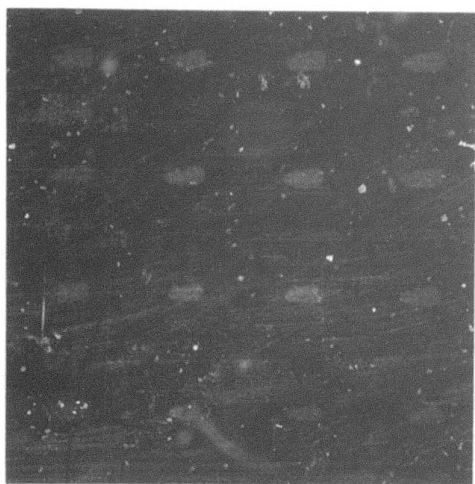

11T

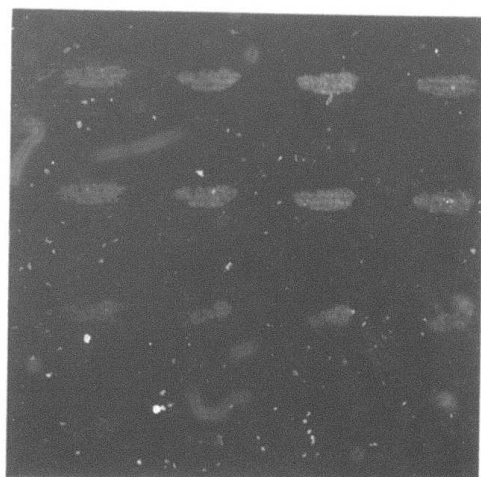

16T

Figure 29 (continued)

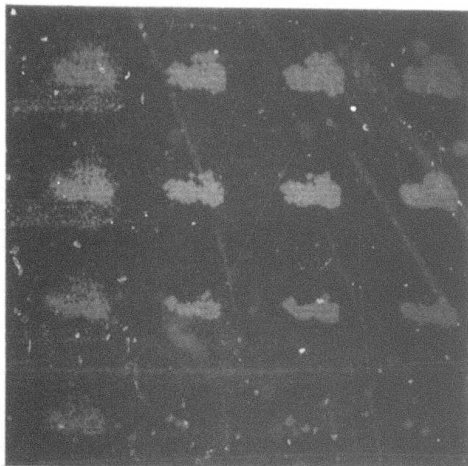

22T

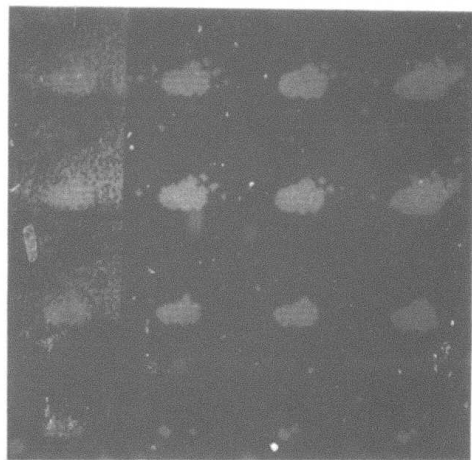

28T

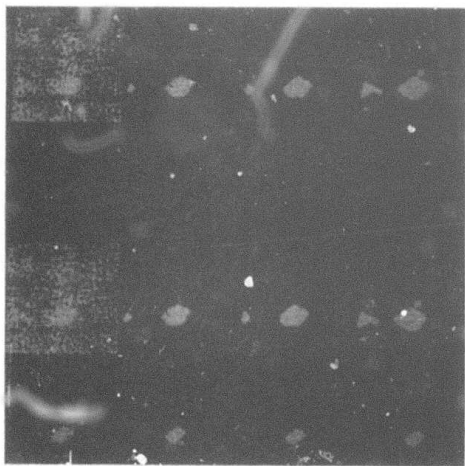

34T

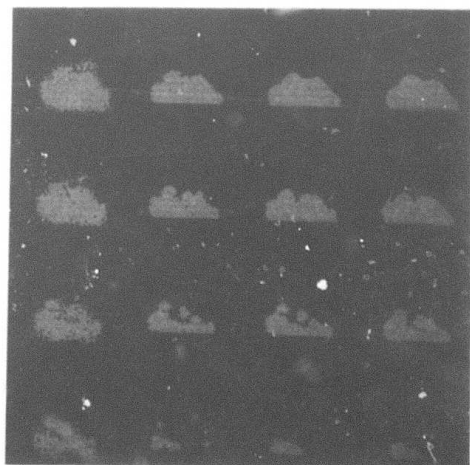

45T

Figure 29 (continued)

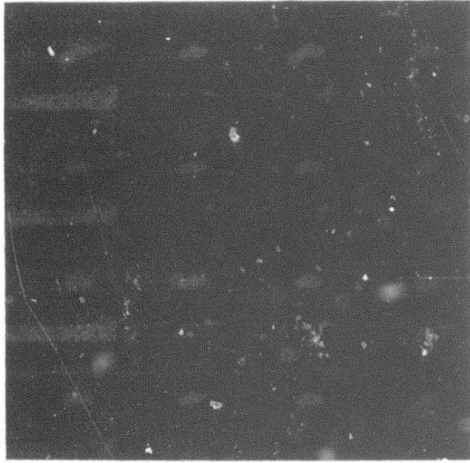

52T

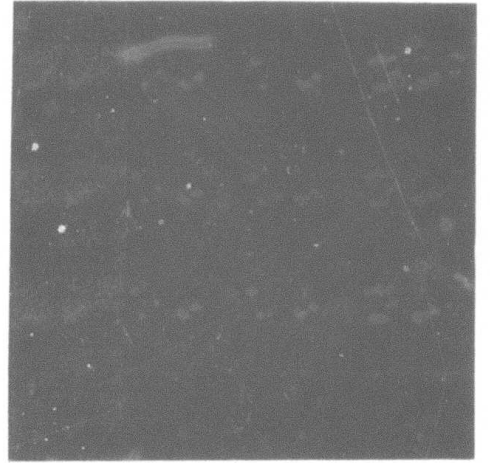

57T

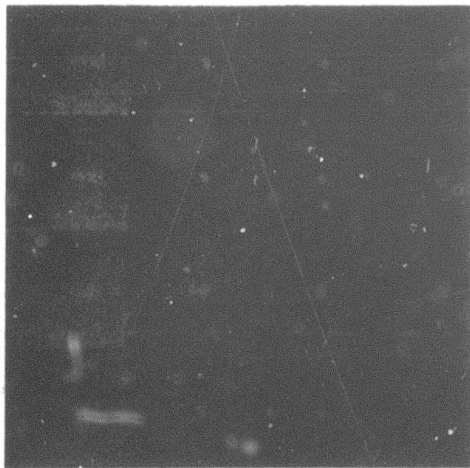

3R

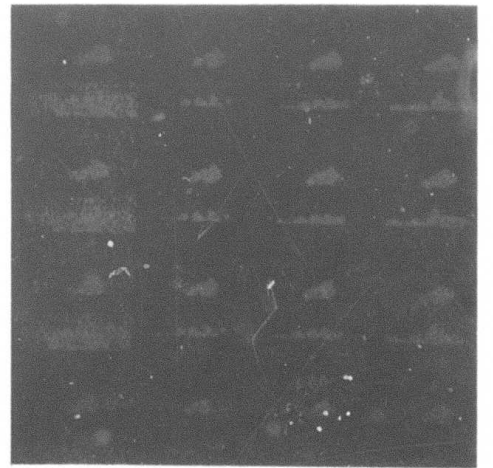

6R

Figure 29 (continued)

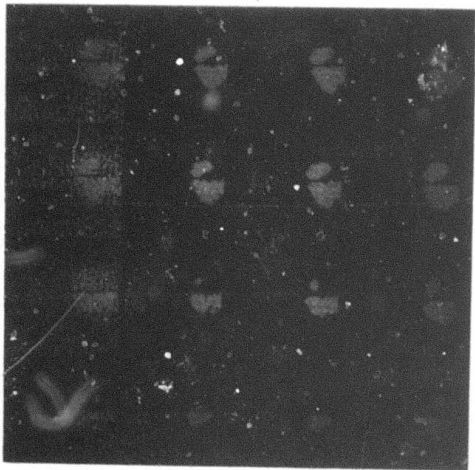

22R

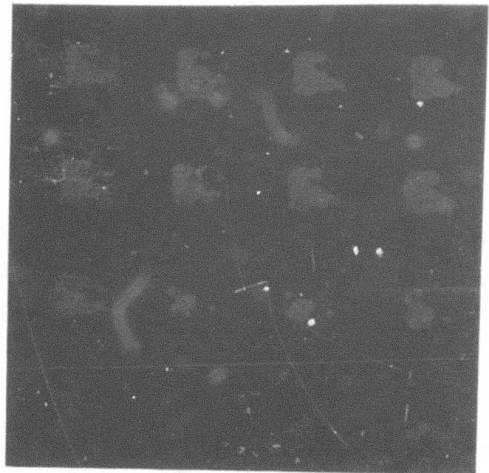

24R

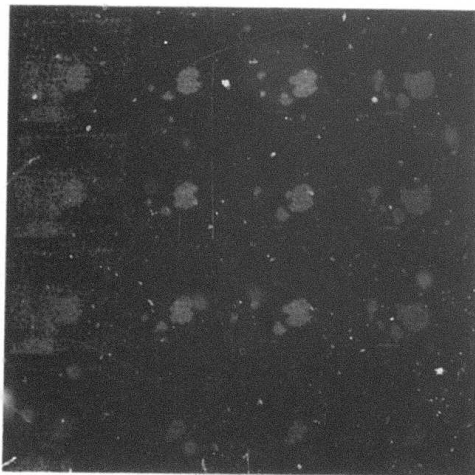

31R

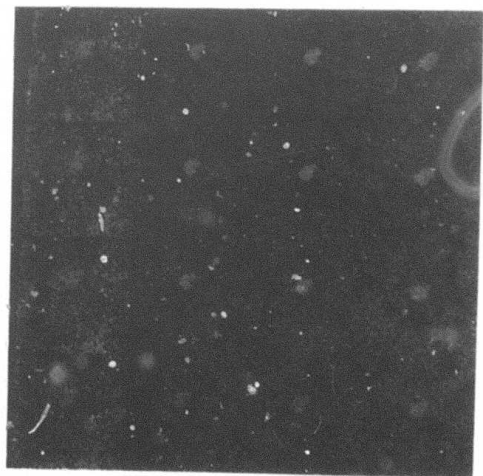

34R

Figure 29 (continued)

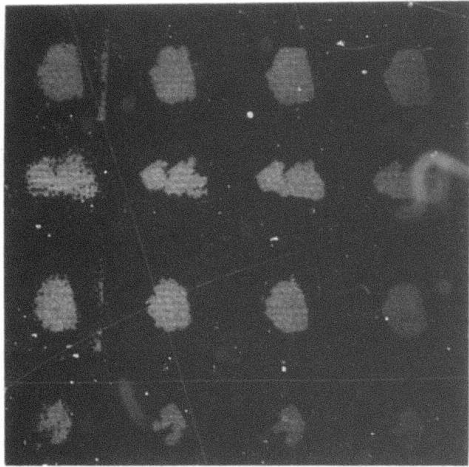

47R

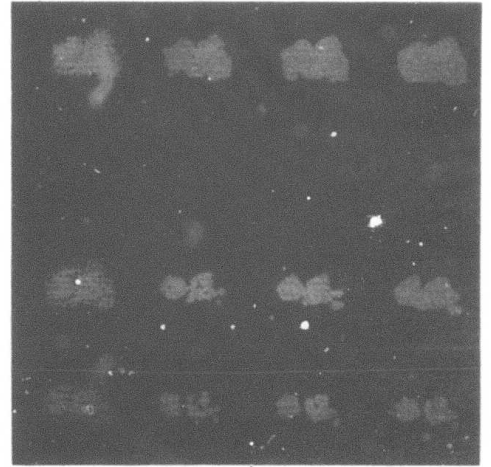

48R

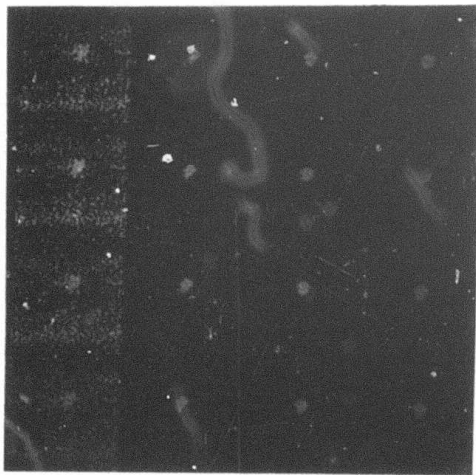

55R

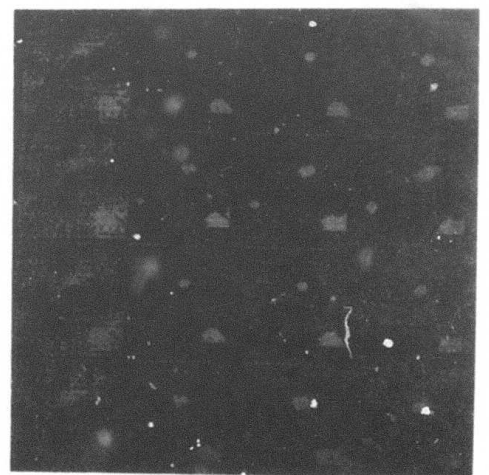

57R

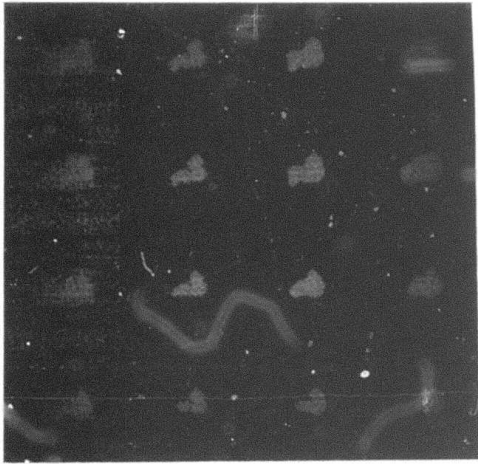

21A

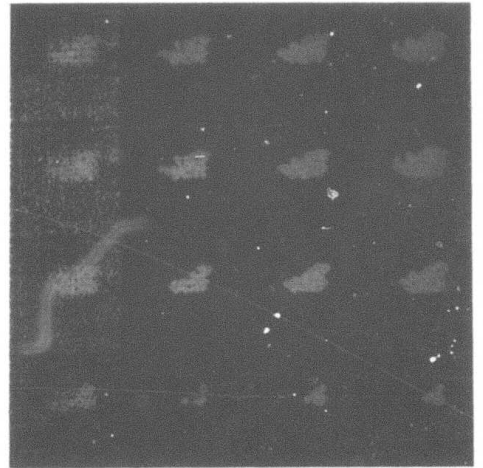

24A

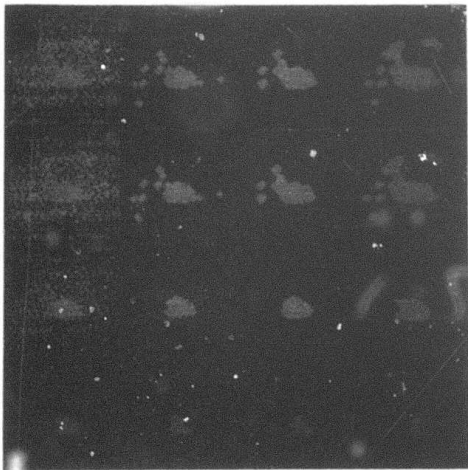

27A

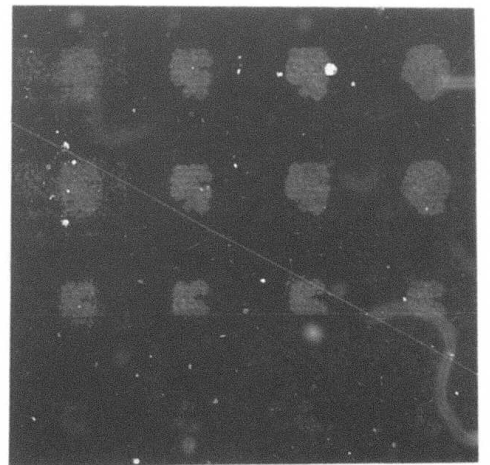

37A

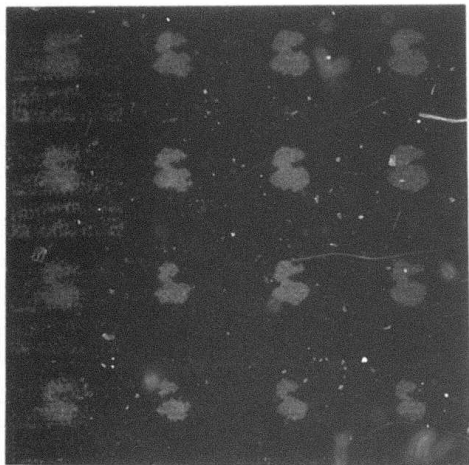

42A

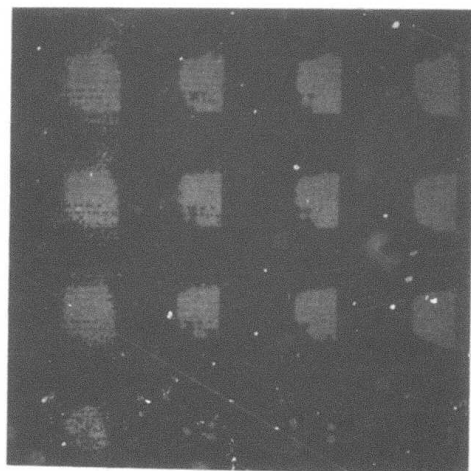

44A

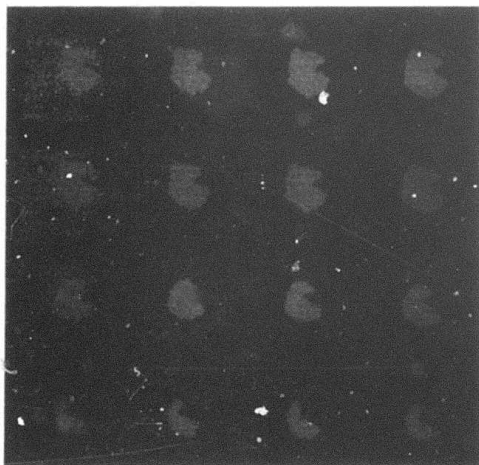

46A

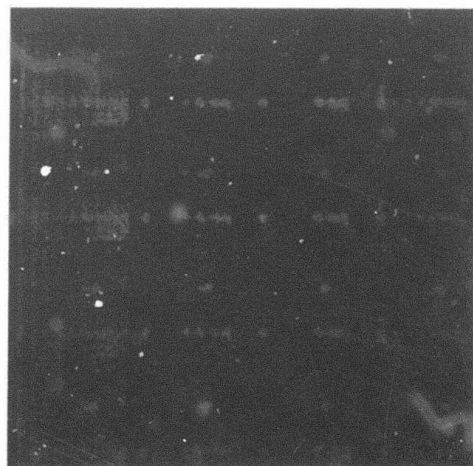

52A

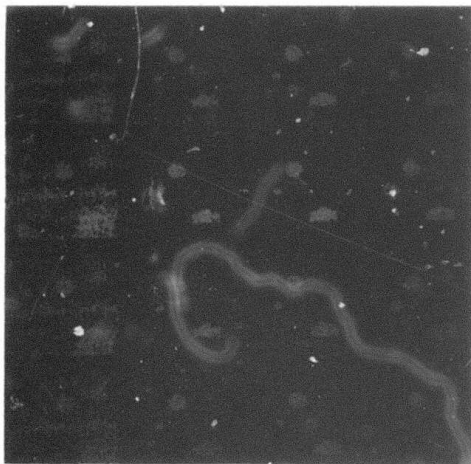

54A

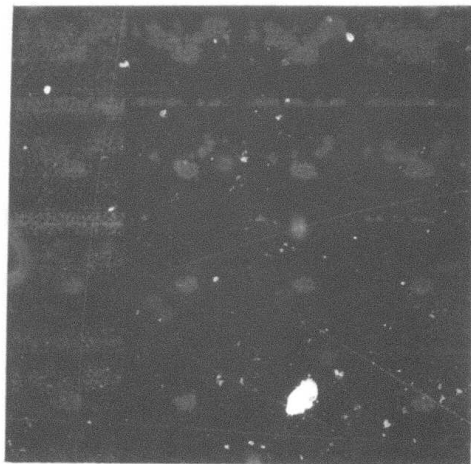

58A

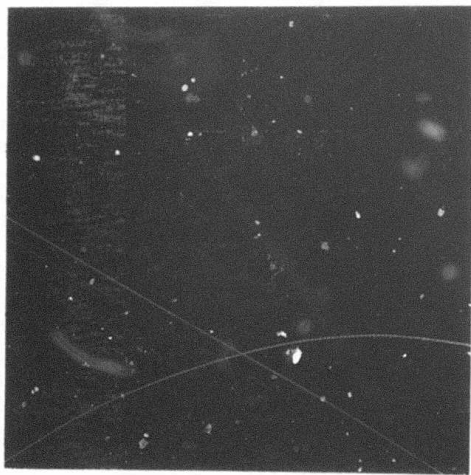

2N

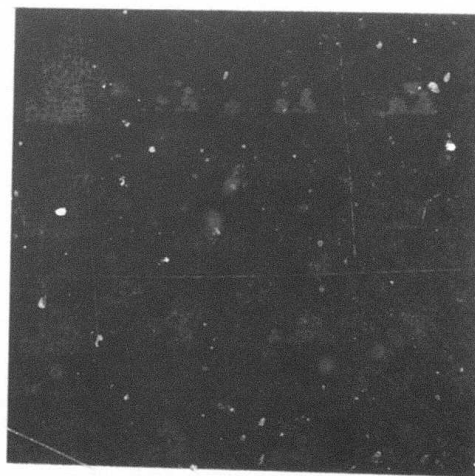

8N



14N



20N

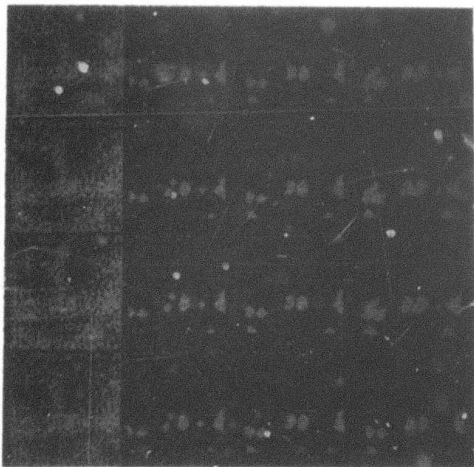

26N

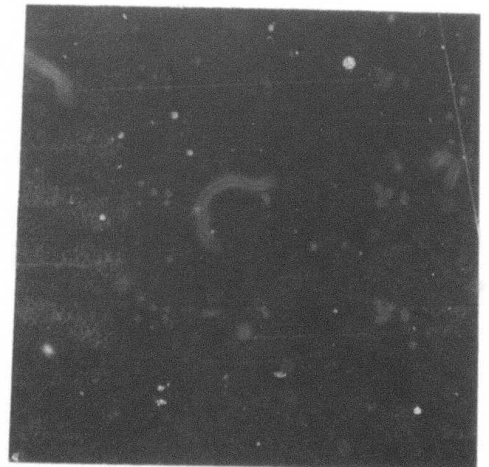

32N

Figure 29 (continued)

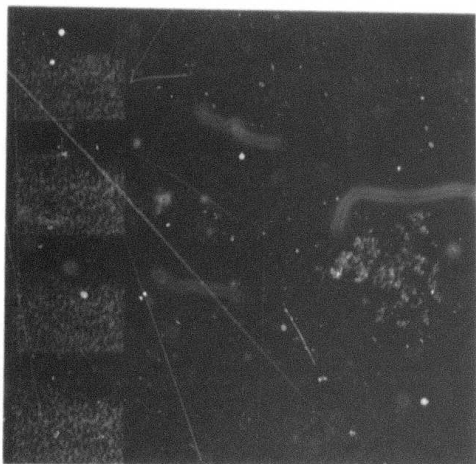

38N

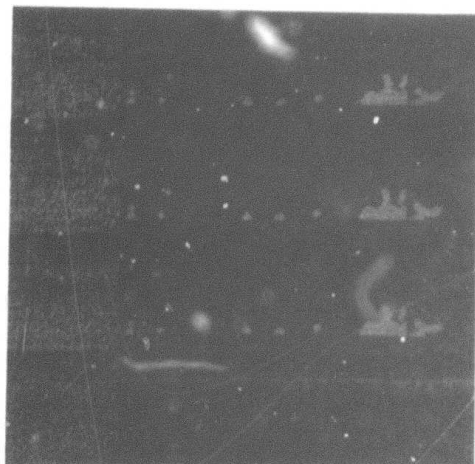

44N

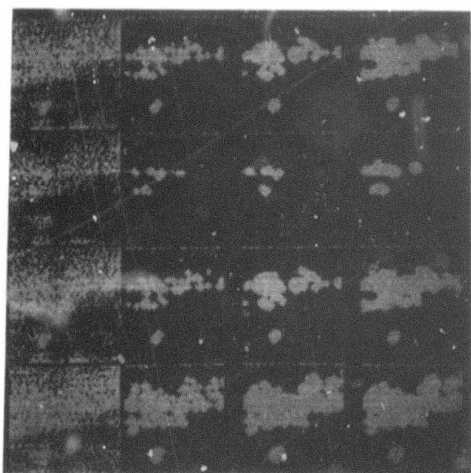

50N

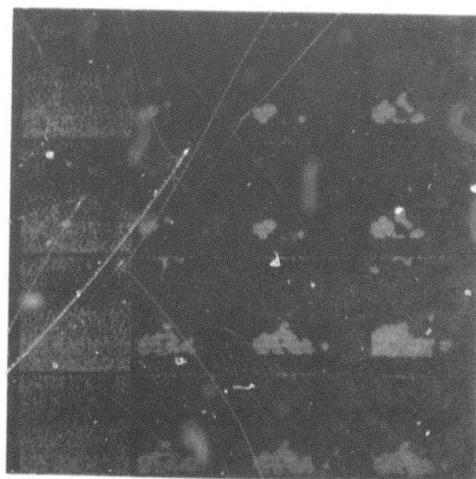

56N

Figure 29 (continued)

E4. Connected Component Analysis and Feature Extraction

The result of thresholding is a binary image. Noise cleaning operations filter this image, but it still remains to aggregate points into identified (labelled) regions. A process which labels the individual disjoint regions in the binary image, in a single raster scan, is well known in the literature [4]. It is described briefly in the following paragraphs.

A set of 1's in a binary image is connected if any two points in it can be joined by a path (sequence) of pairwise adjacent points lying in the set. A maximal connected set is called a connected component. The algorithm to be described produces the (unique) decomposition into connected components and labels the individual components (Figure 30).

As each line of the binary image is processed in turn, it is converted into a list of sequences (runs) of 1's. This list is compared term for term with the list for the previous line. Clearly any run in the current line which is adjacent to (lies underneath) a run in the previous line belongs to the same component as that previous run. Each current run which is adjacent to a previous run receives the label associated with that previous run. If it is adjacent to several previous runs with different labels then it is given one of those labels, and an entry is made in a label equivalence table indicating that these separate runs of the previous line lie in the same

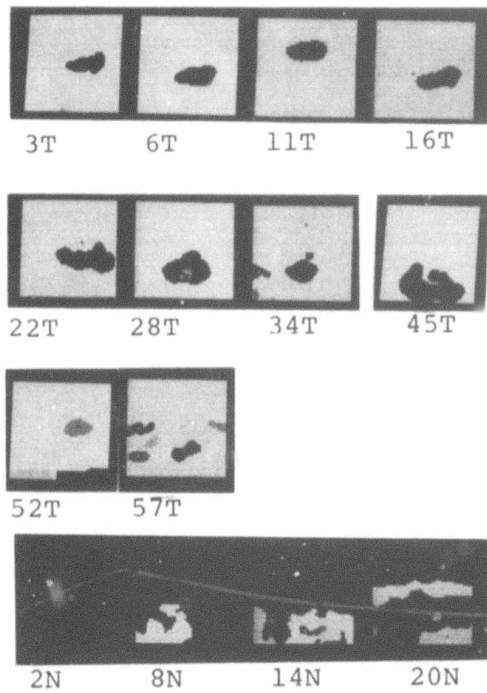

Figure 30. Components labelled with distinct solid gray levels and with centroids displayed as dots.

component. If a current row is adjacent to no previous runs, it is given a new (unused) label. When the current runs have been labeled, the scan is advanced to the next line. Once the final line has been processed, each point has been associated with a single component (possibly involving equivalent labels in the label equivalence table). A second pass can now be used to relabel each point with a unique component label, as illustrated in Figure 30.

As a binary window is being segmented, one can also process the original gray scale window (since they are in register). Various statistics based on geometry and gray level can be extracted for each component segment and accumulated during the pass. The label equivalence table can then be used to combine the statistics for component segments which belong to the same component. The set of components along with the features of each for each window were ordered by component size and stored in files for later use in classification studies. The features evaluated and stored for each component are:

1. Area (number of image points)
2. Average gray level
3. Standard deviation of gray level
4. (Average component gray level) - (Average background gray level)

F. Discrimination and Classification

Given a set of features for objects known to lie in disjoint classes, one desires a classification rule based on the known features which will assign each object to its respective class. Various procedures are known for proposing such rules. The Fisher linear discriminant (cf. [5]) attempts to find the optimum linear projection of the feature vectors onto a line, and the optimum partition of this line, such that the ratio of between-class scatter to within-class scatter is maximized.

An implementation of the Fisher algorithm was used (as described in Section C) to discriminate noise windows from object-bearing windows. In this section, we describe experiments in classifying the components extracted in Section E4 into target/non-target classes.

Using the 13 features described in Section E4, an optimal linear classifier was trained on 30 target components and 59 noise components located in the 30 target windows. When the training set was used as a test set, two of the targets and three of the noise regions were misclassified. Attempts to omit features from the classification resulted in lower scores. For example, in trying to assess the importance of gray level and size, features 2, 3, 4, and 9 were deleted. The resultant misclassifications consisted of four targets and five noise regions (see Tables 4a, 4b).

In Section 2C, the need for an early object detection phase was stated. If non-object-bearing windows are thresholded and segmented into components, many noise regions

| <u>Feature</u> | <u>Fisher Direction</u> |
|----------------|-------------------------|
| 1 | .384-01 |
| 2 | -.559 |
| 3 | -.285 |
| 4 | -.771-01 |
| 5 | -.250 |
| 6 | .519 |
| 7 | .287-01 |
| 8 | .170 |
| 9 | .471 |
| 10 | .348-03 |
| 11 | .103-02 |
| 12 | -.355-01 |
| 13 | -.116 |
| Threshold | -.282+01 |

Target misclassifications: Image ref. nos. 57R, 52A

Table 4a. Fisher linear discriminant results on 30 targets and 59 noise regions using features 1-13.

are generated which may be misclassified as targets, this
increasing the false alarm rate. An experiment verified

| <u>Feature</u> | <u>Fisher Direction</u> |
|----------------|-------------------------|
| 1 | .155-01 |
| 5 | -.483 |
| 6 | -.358 |
| 7 | .311-01 |
| 8 | -.231 |
| 10 | .763 |
| 11 | .135-03 |
| 12 | .151-02 |
| 13 | .441-01 |
| Threshold | -.615+01 |

Target misclassifications: Image ref. nos. 31R,
55R, 57R, 52A

Table 4b. Fisher linear discriminant results
on 30 targets and 59 noise regions
using features 1, 5-8, 10-13.

are generated which may be misclassified as targets, thus increasing the false alarm rate. An experiment verified the need for a separate detection phase. In this experiment when the noise windows were segmented and classified with the target windows (the noise windows contributing only noise components), 28 of 30 targets were recognized while 106 of 114 noise components were correctly identified. Thus of 38 objects identified as targets, 8 are false alarms (see Table 4c).

These experiments, although indicating some degree of success, were run on windows chosen by human observers as having only moderate amounts of noise. In unprocessed images, the likelihood of a noise window may be far greater than the likelihood of an object window, and so the object detection phase false alarm rate for noise windows (in this case, 2 out of 10) is a crucial parameter. The classification aspect of this project must be broadened in every way -- a larger data base, more informed feature selection, and a better classification strategy (e.g., Bayes) -- both in the object detection phase and in the component classification phase.

A. Data sets

The following are investigated by to have been

| <u>Feature</u> | <u>Fisher Direction</u> |
|----------------|-------------------------|
| 1 | .305-01 |
| 2 | -.580 |
| 3 | -.341 |
| 4 | -.141 |
| 5 | -.144 |
| 6 | .489 |
| 7 | .148 |
| 8 | -.240 |
| 9 | .377 |
| 10 | -.674-04 |
| 11 | .979-03 |
| 12 | -.105 |
| 13 | -.185 |
| Threshold | -.426+01 |

Target misclassifications: Image ref. nos. 57R, 52A

Table 4c. Fisher linear discriminant results on 30 targets and 114 noise regions using features 1-13.

3. Plans for the next quarter

A. Data Sets

The algorithms investigated up to now have been tested on a data set consisting of 40 images, selected from a larger data base of 90 frames containing 137 targets, as described in Section 2. More extensive tests, involving the entire data base, are planned. An additional data base has just been obtained, and it too will be used in future experiments. It is planned to acquire at least two further data bases which will also provide test data. The use of multiple data bases will serve as a check on the generality of both algorithms and image models. One of the data sets to be acquired will consist of real-time sequences of frames, and this will make it possible to study temporal aspects of the target detection process, including tracking of targets from frame to frame.

B. Models

A first-approximation model for target segmentation, based on histogramming the joint occurrences of edge values and gray levels in an image, has been developed, as described in Section 2B. This model has suggested a number of segmentation strategies involving classification in edge/gray level space, rather than pure thresholding or pure edge detection. These strategies need to be investigated. Also, other types of models based on local property co-occurrences should be formulated and studied. It is expected that this work will lead to an increased understanding of the image segmentation and target detection problem.

C. Windows

The experiments performed during the past quarter have employed square image windows which may or may not contain targets. The distance to the ground area covered by such a window depends on the position of the window within the frame (as well as on the attitude and altitude of the sensor). Normally, windows near the top of a frame will show more distant parts of the terrain, while those near the bottom will show closer parts, so that targets will appear smaller near the top than near the bottom. The radiation reaching the sensor from a window also depends on distance. This information can and should be used in choosing parameter values for the algorithms that are applied to a window.

D. Algorithms

The algorithms described in Section 2 primarily involve edge detection and threshold selection. Other types of algorithms, e.g., for spot detection, still need to be investigated. [More advanced image segmentation techniques can also be explored, e.g., techniques based on relaxation labelling, but such techniques would be difficult to implement under the present hardware constraints.] Preprocessing techniques can also be explored, aimed at reducing the noisiness of the images to facilitate clean segmentation. Median filtering is a good example of such a technique; it is especially appropriate since histogramming is already being used in the analysis of the images.

E. Classifiers

In the experiments carried out thus far, a simple Fisher linear discriminant classifier has been used. It is planned to investigate the advantages of more powerful (e.g., maximum-likelihood) classifiers. In particular, the trade-off between false alarm and false dismissal rates will be explored. Sequential decision procedures, e.g., decision trees, will also be investigated. In this connection, it is planned to make use of the Maryland Interactive Pattern Analysis and Classification System (MIPACS) in the Laboratory for Pattern Analysis at the University, which provides a wide range of tools for classifier design.

F. Target Identification

The work done during the first quarter has dealt almost entirely with target detection and segmentation from the background. The problem of identifying targets as belonging to specific classes (e.g., tanks, trucks, etc.) must also be studied. It is planned to apply recent research results on shape description to the design of features for the target identification problem.

References

1. L. S. Davis, A. Rosenfeld, and N. Ahuja, Piecewise approximation of pictures using maximal neighborhoods, Technical Report 455, Computer Science Center, University of Maryland, College Park, MD., May 1976.
2. N. Ahuja, L. S. Davis, D. L. Milgram, and A. Rosenfeld, Piecewise approximation of pictures: further experiments, Technical Report 462, Computer Science Center, University of Maryland, College Park, MD., July 1976.
3. J. S. Weszka, R. N. Nagel, and A. Rosenfeld, A threshold selection technique, IEEE Trans. Computers C-23, 1974, 1322-1326.
4. A. Rosenfeld and J. L. Pfaltz, Sequential operations in digital picture processing, J.ACM 31, 1966, 471-494.
5. R. O. Duda and P. E. Hart, Pattern Classification and Scene Analysis, Wiley, New York, 1973, Sec. 4.10.

UNCLASSIFIED

SECURITY CLASSIFICATION OF THIS PAGE (When Data Entered)

| REPORT DOCUMENTATION PAGE | | READ INSTRUCTIONS BEFORE COMPLETING FORM |
|--|-----------------------|---|
| 1. REPORT NUMBER | 2. GOVT ACCESSION NO. | 3. RECIPIENT'S CATALOG NUMBER |
| 4. TITLE (and Subtitle) ⑥ Algorithms and Hardware Technology For Image Recognition. | | 5. TYPE OF REPORT & PERIOD COVERED ⑨ Quarterly <i>rept.</i> 1 May-31 Jul 1976 |
| 7. AUTHOR(s) ⑩ Azriel Rosenfeld David Milgram | | 6. PERFORMING ORG. REPORT NUMBER |
| 9. PERFORMING ORGANIZATION NAME AND ADDRESS Computer Science Center Univ. of Maryland College Park, MD 20742 | | 8. CONTRACT OR GRANT NUMBER(s) ⑮ DAAG53-76C-0138 ✓ DARPA Order-3206 |
| 11. CONTROLLING OFFICE NAME AND ADDRESS U. S. Army Night Vision Lab. AMSEL-NV-VI Ft. Belvoir, VA 22060 | | 10. PROGRAM ELEMENT, PROJECT, TASK AREA & WORK UNIT NUMBERS ⑫ 139p. |
| 14. MONITORING AGENCY NAME & ADDRESS (if different from Controlling Office) | | 12. REPORT DATE ⑬ 31 Jul 1976 |
| | | 13. NUMBER OF PAGES 139 |
| | | 15. SECURITY CLASS. (of this report) Unclassified |
| | | 15a. DECLASSIFICATION/DOWNGRADING SCHEDULE |
| 16. DISTRIBUTION STATEMENT (of this Report) Approved for public release; distribution unlimited | | |
| 17. DISTRIBUTION STATEMENT (of the abstract entered in Block 20, if different from Report) | | |
| 18. SUPPLEMENTARY NOTES | | |
| 19. KEY WORDS (Continue on reverse side if necessary and identify by block number) Image understanding Image processing Pattern recognition Target detection FLIR imagery | | |
| 20. ABSTRACT (Continue on reverse side if necessary and identify by block number) → Techniques for detecting tactical targets on Forward-Looking Infrared (FLIR) imagery are being investigated. The principal topics covered include target and background models, object extraction and classification, and hardware technology applicable to real-time implementation. ← | | |