

**U.S. DEPARTMENT OF COMMERCE  
National Technical Information Service**

AD-A035 152

DESIGN OF SELECTED HELICOPTER COMPONENTS  
FOR EASE OF REPAIR

KAMAN AEROSPACE CORPORATION  
BLOOMFIELD, CONNECTICUT

DECEMBER 1976

ADA035152

JSAAMRDL-TR -76-34



**DESIGN OF SELECTED HELICOPTER COMPONENTS  
FOR EASE OF REPAIR**

**Kaman Aerospace Corporation  
Old Windsor Road  
Bloomfield, Conn. 06002**

**December 1976**

**Final Report for Period April 1975 - May 1976**

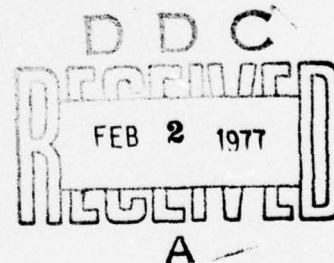

Approved for public release;  
distribution unlimited.

**Prepared for**

**EUSTIS DIRECTORATE  
U. S. ARMY AIR MOBILITY RESEARCH AND DEVELOPMENT LABORATORY  
Fort Eustis, Va. 23604**

REPRODUCED BY  
**NATIONAL TECHNICAL  
INFORMATION SERVICE**  
U. S. DEPARTMENT OF COMMERCE  
SPRINGFIELD, VA. 22161

## EUSTIS DIRECTORATE POSITION STATEMENT

This investigation is one of a series being conducted by the Eustis Directorate, U. S. Army Air Mobility Research and Development Laboratory, to improve maintainability characteristics of future helicopter designs. The specific objective of this effort was to investigate the problems associated with field level repair of selected major dynamic components and, subsequently, to develop design concepts that would reduce or eliminate repair difficulty.

This Directorate concurs in the findings presented herein and recommends the results be used to establish future qualitative maintainability design requirements. Furthermore, the problem analyses described in the report provide an excellent source of data for use in the maintainability design reviews. Because the ferrofluidic seal concept investigated under this program is considered to offer noteworthy potential for elimination of many gearbox seal problems, this Directorate is currently planning to evaluate the concept in the near future.

Mr. John Ariano, Military Operations Technology Division, served as technical monitor for this contract.

### DISCLAIMERS

The findings in this report are not to be construed as an official Department of the Army position unless so designated by other authorized documents.

When Government drawings, specifications, or other data are used for any purpose other than in connection with a definitely related Government procurement operation, the United States Government thereby incurs no responsibility nor any obligation whatsoever; and the fact that the Government may have formulated, furnished, or in any way supplied the said drawings, specifications, or other data is not to be regarded by implication or otherwise as in any manner licensing the holder or any other person or corporation, or conveying any rights or permission, to manufacture, use, or sell any patented invention that may in any way be related thereto.

Trade names cited in this report do not constitute an official endorsement or approval of the use of such commercial hardware or software.

### DISPOSITION INSTRUCTIONS

Destroy this report when no longer needed. Do not return it to the originator.

**UNCLASSIFIED**

SECURITY CLASSIFICATION OF THIS PAGE (When Data Entered)

REPORT DOCUMENTATION PAGE		READ INSTRUCTIONS BEFORE COMPLETING FORM
1. REPORT NUMBER USAAMRDL-TR-76-34	2. GOVT ACCESSION NO.	3. RECIPIENT'S CATALOG NUMBER
4. TITLE (and Subtitle) DESIGN OF SELECTED HELICOPTER COMPONENTS FOR EASE OF REPAIR		5. TYPE OF REPORT & PERIOD COVERED Final Report April 1975 - May 1976
7. AUTHOR(s) Thomas N. Cook Frank E. Starses Charles J. Wirth		6. PERFORMING ORG. REPORT NUMBER R-1464
9. PERFORMING ORGANIZATION NAME AND ADDRESS Kaman Aerospace Corporation Old Windsor Road Bloomfield, Connecticut 06002		8. CONTRACT OR GRANT NUMBER(s) DAAJ02-75-C-0029
11. CONTROLLING OFFICE NAME AND ADDRESS Eustis Directorate, U. S. Army Air Mobility Research and Development Lab. Fort Eustis, Virginia 23604		10. PROGRAM ELEMENT, PROJECT, TASK AREA & WORK UNIT NUMBERS 62209A 1F262209AH76 00 060 EK
14. MONITORING AGENCY NAME & ADDRESS (if different from Controlling Office)		12. REPORT DATE December 1976
		13. NUMBER OF PAGES 165
		15. SECURITY CLASS. (of this report) UNCLASSIFIED
16. DISTRIBUTION STATEMENT (of this Report) Approved for public release; distribution unlimited.		15a. DECLASSIFICATION/DOWNGRADING SCHEDULE
17. DISTRIBUTION STATEMENT (of the abstract entered in Block 20, if different from Report)		
18. SUPPLEMENTARY NOTES		
19. KEY WORDS (Continue on reverse side if necessary and identify by block number)		
Helicopter	Repair	Maintainability
Mechanical Component	Maintenance	Design Study
Gearbox	Repair Time	
Rotor Head	Man-Hours	
20. ABSTRACT (Continue on reverse side if necessary and identify by block number)		
<p>This report examines the design of major helicopter components and its effect on the man-hour cost of field repair. Recommendations are developed for improving the field repairability of these components on future helicopters through improved applications of current technology and new design concepts.</p> <p>The study was accomplished in two phases. In the first, field surveys were conducted to identify significantly occurring (over)</p>		

UNCLASSIFIED

SECURITY CLASSIFICATION OF THIS PAGE(When Data Entered)

20. ABSTRACT (continued)

repair actions in the field and the important elements of each repair task. Comments on repair problems were solicited from Army mechanics. Nine generic types of components on six helicopter models were investigated. Solutions available through improved applications of current technology were identified, and recommended design study projects were submitted for Army approval.

In Phase II, design studies were conducted for five generic types of parts found to be most significant from the standpoint of the man-hours they consume in repair and/or the number of complaints they received from mechanics in the field. Twenty-five design concepts were investigated. Each was subjected to an engineering critique that considered the effects on such factors as cost, weight, stress and performance.

Several important conclusions were reached concerning the scope of major component repair. It was determined that extensive repairs are not being done in the field, even at G. S. level. The repairs that are being made involve, usually, very limited disassembly and the replacement of relatively simple parts, primarily seals. Seals of all types are, by far, the largest consumers of repair time.

UNCLASSIFIED

SECURITY CLASSIFICATION OF THIS PAGE(When Data Entered)

PREFACE

This report was prepared by Kaman Aerospace Corporation of Bloomfield, Connecticut, for the Eustis Directorate, U. S. Army Air Mobility Research and Development Laboratory (USAAMRDL), Fort Eustis, Virginia, under Contract DAAJ02-75-C-0029. Mr. John Ariano was the Contract Technical Monitor for the Army.

The principal design investigative work was conducted by Mr. Charles Wirth of the Kaman technical staff. Many other members of the Kaman staff contributed significantly to the program; the authors wish to acknowledge, especially, Messrs. R. Bossler, G. Lubben, E. Sorant and R. Hintermister.

UNCLASSIFIED	
CLASS	White Section <input checked="" type="checkbox"/>
DOC	Dist Section <input type="checkbox"/>
UNCLASSIFIED	<input type="checkbox"/>
JUSTIFICATION	
BY	
DISTRIBUTION/AVAILABILITY CODES	
Dist.	AVAIL. AND/OR SPECIAL
A	

TABLE OF CONTENTS

	<u>Page</u>
PREFACE. . . . .	3
LIST OF ILLUSTRATIONS. . . . .	8
LIST OF TABLES . . . . .	12
INTRODUCTION . . . . .	14
STUDY METHODS. . . . .	19
Problem Identification and Analysis . . . . .	19
Design Study. . . . .	28
OVERALL RESULTS AND FINDINGS . . . . .	29
Qualitative Survey Results. . . . .	29
Quantitative Survey Results . . . . .	32
SURVEY RESULTS AND DESIGN STUDY. . . . .	39
GEARBOX AND ROTOR HEAD LIP SEALS. . . . .	39
Repair Time Data and Field-Reported Problems. . . . .	39
Gearbox Input and Output Seals. . . . .	39
Rotor Head and Swashplate Seals . . . . .	54
Design Studies. . . . .	58
Lip Seal With Built-in Removal Provisions . . . . .	59
Split Lip Seal. . . . .	65
Slip-Over Lip Seal. . . . .	66
Ferrofluidic Seal . . . . .	68
Viscous Fluid Seal. . . . .	72
GEARBOX CARBON SEALS. . . . .	74
Repair Time Data and Field-Reported Problems. . . . .	74
HYDRAULIC ACTUATOR O-RING SEALS . . . . .	78
Repair Time Data and Field-Reported Problems. . . . .	78
Design Studies. . . . .	82

**Preceding page blank**

TABLE OF CONTENTS (continued)

	<u>Page</u>
"Murphy-Proof" Undercuts in Servo Head. . . . .	82
Optimized Dual Actuator Design. . . . .	84
Segmented Servo Head Sleeve . . . . .	86
STATIC SEALS. . . . .	90
Repair Time Data and Field-Reported Problems. . . . .	90
BEARINGS AND BEARING SURFACES . . . . .	92
Repair Time Data and Field-Reported Problems. . . . .	92
Anti-Friction Ball or Roller Bearings . . . . .	92
Teflon Bushings and Uniball Seats . . . . .	94
Spherical Bearings and Rod Ends . . . . .	99
Design Studies. . . . .	.101
Swashplate Uniball With Threaded Seats. . . . .	.101
Unloaded Uniball With Spring Seat . . . . .	.103
Grease Fitting for Bearing Removal. . . . .	.104
Grease Fitting for Tapered Pin Removal. . . . .	.106
OIL LEVEL SIGHT GLASSES . . . . .	.108
Repair Time Data and Field-Reported Problems. . . . .	.108
Design Studies. . . . .	.112
Sight Glass with High-Contrast Fresnel Lens . . . . .	.113
Top Viewing Sight Gauge with High-Contrast Lens. . . . .	.115
Sight Gauge with Self-Closing Valve . . . . .	.116
Large-Diameter Sight Glass with "VEE" Band Clamp . . . . .	.116
Sight Gauge with Segregated Indicating Fluid. . . . .	.119
Remote Electronic Liquid Level Indicators . . . . .	.120
Remote Mechanical Liquid Level Indicator. . . . .	.122
RUBBER BOOTS. . . . .	.125
Repair Time Data and Field-Reported Problems. . . . .	.125
Design Studies. . . . .	.127
Boot With Longitudinal Split Through Convolutions. . . . .	.127

TABLE OF CONTENTS (continued)

	<u>Page</u>
Wrap-Around Preformed Tape Boot . . . . .	.130
Snap Segment Boot . . . . .	.132
OIL FILTERS AND RESERVOIRS. . . . .	.134
Repair Time Data and Field-Reported Problems. . .	.134
MECHANICAL STOPS AND PADS . . . . .	.136
Repair Time Data and Field-Reported Problems. . .	.136
CONCLUSIONS. . . . .	.139
RECOMMENDATIONS. . . . .	.142
REFERENCES . . . . .	.143
APPENDIX A   TABULATED FIELD SURVEY RESULTS. . . . .	.144

LIST OF ILLUSTRATIONS

<u>Figure</u>		<u>Page</u>
1	Sample field survey form. . . . .	22
2	Fleet-wide man-hours expended on seal replacements. . . . .	36
3	Limited access to transmission input quill, OH-58 helicopter . . . . .	43
4	Accessory drive section, CH-47 aft transmission. . . . .	44
5	UH-1 transmission input quills. . . . .	45
6	Rubber plug temporarily inserted in roller bearing, UH-1 transmission. . . . .	46
7	Insertion of input quill, UH-1 transmission . . . .	47
8	Exploded view of input quill, OH-58 transmission. . . . .	48
9	Location of laminated shims behind input bearing/seal housing, OH-58 transmission. . . . .	49
10	Installation of locking spring in adapter retaining nut, OH-58 transmission . . . . .	50
11	Output seal, OH-6 tail rotor gearbox. . . . .	51
12	Lockwiring output cover, OH-6 tail rotor gearbox . . . . .	51
13	Tail rotor take-off seal, UH-1 transmission . . . .	52
14	Brushable sealer on output seal housing, OH-58 tail rotor gearbox. . . . .	53
15	Exploded view, OH-58 main rotor hub . . . . .	55
16	Pitch horn removed from grip, UH-1 main rotor hub assembly. . . . .	57
17	Lip seal with expandable rubber retaining ring. . . . .	60
18	Lip seal with O-ring retainer . . . . .	61

LIST OF ILLUSTRATIONS (continued)

<u>Figure</u>		<u>Page</u>
19	Lip seal with leaf spring retainers . . . . .	63
20	Lip seal with snap ring retainer. . . . .	64
21	Split lip seal. . . . .	66
22	Slip-over lip seal. . . . .	67
23	Typical ferrofluidic seal . . . . .	69
24	Conceptual application of a ferrofluidic seal to the inboard end of UH-1H main rotor grip. . . . .	70
25	Viscous fluid seal. . . . .	73
26	Rotor brake installation, CH-54 transmission. . . . .	75
27	Input spanner nut, CH-54 transmission . . . . .	76
28	Special socket in-place, input spanner nut, CH-54 transmission. . . . .	77
29	Use of pick to remove hydraulic actuator O-ring seals. . . . .	80
30	AH-1 hydraulic actuator, partial assembly . . . . .	81
31	Murphy-proof undercuts in servo head. . . . .	83
32	Optimized dual actuator design. . . . .	85
33	Typical hydraulic actuator design . . . . .	87
34	Segmented servo head sleeve . . . . .	88
35	Reservoir cover attachment studs, CH-47 combining transmission. . . . .	91
36	Gimbal ring attachment bolt and nut, UH-1 swashplate. . . . .	94
37	Removal of uniball spherical seats, AH-1 swashplate. . . . .	96
38	Uniball friction adjustment, AH-1 swashplate. . . . .	97

LIST OF ILLUSTRATIONS (continued)

<u>Figure</u>		<u>Page</u>
39	Exploded view, AH-1 main rotor hub. . . . .	98
40	Removing extension-to-yoke attach bolts, AH-1 main rotor hub . . . . .	99
41	Dynamic balancer, OH-6 tail rotor . . . . .	100
42	Swashplate uniball with threaded seats. . . . .	102
43	Unloaded swashplate uniball with spring seat. . . . .	104
44	Grease fitting for bearing removal. . . . .	105
45	Grease fitting for tapered pin removal. . . . .	106
46	Sight glass window inaccessibility, CH-47 forward transmission. . . . .	110
47	Sight glass windows, CH-47 combining transmission. . . . .	111
48	Use of multiple gaskets, sight glass, CH-47 forward transmission. . . . .	112
49	Sight gauge with high-contrast fresnel lens . . . . .	113
50	Sight gauge with standard lens. . . . .	114
51	Top-viewing sight gauge with high-contrast fresnel lens. . . . .	115
52	Sight gauge with self-closing valve . . . . .	117
53	Large-diameter sight glass with "Vee" band clamp . . . . .	118
54	Sight gauge with segregated indicating fluid . . . . .	119
55	Ultrasonic liquid level indicator . . . . .	121
56	Remote mechanical fluid level indicator . . . . .	123
57	"Bottomed-out" boot clamp, UH-1 hydraulic actuator. . . . .	126

LIST OF ILLUSTRATIONS (continued)

<u>Figure</u>		<u>Page</u>
58	Stripped Phillips head screw, UH-1 hydraulic actuator. . . . .	.127
59	Boot with longitudinal split through convolutions. . . . .	.128
60	Wrap-around, preformed tape boot. . . . .	.130
61	Snap segment boot . . . . .	.133
62	Bonding lead-lag stop, OH-6 main rotor hub. . . . .	.137
63	Fretting inhibitor buffers being bonded to extension, top view, AH-1 main rotor hub. . . . .	.138

LIST OF TABLES

<u>Table</u>		<u>Page</u>
1	Field Survey Schedule . . . . .	20
2	Field Survey Response . . . . .	32
3	Fleet Size and Utilization Data and Repair Time Weighting Factors. . . . .	33
4	Fleet-Wide Repair Man-Hours by Generic Component Group . . . . .	34
5	Fleet-Wide Repair Man-Hours by Generic Parts Group . . . . .	35
6	Fleet-Wide Average Repair Time by Generic Parts Group . . . . .	37
7	Fleet-Wide Average Repair Time by Generic Component Group . . . . .	38
8	Repair Time Data, Gearbox Input Seals . . . . .	40
9	Repair Time Data, Gearbox Output Seals. . . . .	42
10	Repair Time Data, Rotor Head and Swashplate Seals . . . . .	54
11	Repair Time Data, Gearbox Carbon Seals. . . . .	74
12	Repair Time Data, Hydraulic Actuator O-Ring Seals . . . . .	79
13	Repair Time Data, Static Seals. . . . .	90
14	Repair Time Data, Anti-Friction Ball or Roller Bearings . . . . .	93
15	Repair Time Data, Teflon Bushings and Uniball Seats . . . . .	95
16	Repair Time Data, Spherical Bearings and Rod Ends. . . . .	.100
17	Repair Time Data, Oil Level Sight Glasses . . . . .	.109
18	Repair Time Data, Rubber Boots. . . . .	.126

LIST OF TABLES (continued)

<u>Table</u>		<u>Page</u>
19	Repair Time Data, Oil Filters and Reservoirs. . . . .	.134
20	Repair Time Data, Mechanical Stops and Pads . . . . .	.136
A-1	Component Repair Data, OH-58 Helicopter . . . . .	.145
A-2	Component Repair Data, OH-6 Helicopter. . . . .	.148
A-3	Component Repair Data, UH-1 Helicopter. . . . .	.149
A-4	Component Repair Data, AH-1 Helicopter. . . . .	.154
A-5	Component Repair Data, CH-47 Helicopter . . . . .	.158
A-6	Component Repair Data, CH-54 Helicopter . . . . .	.162

## INTRODUCTION

### BACKGROUND

Maintenance problems with the Army's helicopter fleet are being studied as part of an ongoing program of the Eustis Directorate, USAAMRDL, aimed at improving the maintainability of future aircraft. It is the objective of this program to identify the characteristics of the present-day design contributing to the high man-hour cost of maintenance and to develop concepts and principles for improved designs of the future. This report covers the third of three related studies completed under this program.

Under Contract DAAJ02-72-C-0065<sup>1</sup>, the first of the three studies, an analysis was made of the maintainability characteristics of major helicopter components. Based on examinations of historical data on six different helicopter models and extensive interviews with Army field personnel, maintenance tasks consuming large numbers of man-hours in the field were identified. It was determined that the preponderance of maintenance time is involved with the removal and installation of these components, and further analysis was directed toward assessing the contribution of specific tasks (fault isolation, access, buildup, etc.) to the total man-hours consumed. Comments received from Army field personnel, together with step-by-step analysis of maintenance procedures, disclosed areas of component installation design causing difficulty with the removal and installation tasks. Using the knowledge acquired from the study, a checklist for the maintainability analysis of future helicopter designs was prepared.

The maintenance difficulties caused by the design of major component installations in current-inventory Army helicopters were examined further in the second of the three studies, conducted

1. Cook, T. N., Young, R. L., and Starses, F. E., MAINTAINABILITY ANALYSIS OF MAJOR HELICOPTER COMPONENTS, Kaman Aerospace Corporation; USAAMRDL Technical Report 73-43, Eustis Directorate, U. S. Army Air Mobility Research and Development Laboratory, Fort Eustis, Virginia, August 1973, AD 769941.

under Contract DAAJ02-73-C-0082<sup>2</sup>. Recommendations, involving both improved applications of current technology and new engineering concepts, were developed for the design of future aircraft. Each of the new design concepts was subjected to a trade-off type of analysis in which the expected gains of the design were weighed against its potential penalties. Such factors as stress, weight, cost and performance were considered.

#### PROGRAM OBJECTIVES

The third study, the one covered by this report, has followed a similar line of investigation to examine another important aspect of the maintainability problem, that of major component repair in the field. Nine generic helicopter components were specified by the Army for inclusion in the study:

1. Main Transmission (Aft/Forward/Combining)
2. Intermediate Gearbox
3. Tail Rotor Gearbox
4. Main Rotor Hub
5. Tail Rotor Hub
6. Swashplate and Support Assembly
7. Hydraulic Servo Actuator
8. Starter Generator/DC Generator/AC Generator
9. APP/APU Systems

Each of the nine generic component types was to be analyzed to determine deficiencies in the design for repair as applicable to the following current-inventory Army helicopters:

1. UH-1           Utility
2. AH-1           Attack

2. Cook, T. N., Stareses, F. E., and Haire, G. W., ARMY AIR-CRAFT SUBSYSTEM AND COMPONENT INSTALLATION DESIGN INVESTIGATION, Kaman Aerospace Corporation, USAAMRDL Technical Report 75-7, Eustis Directorate, U. S. Army Air Mobility Research and Development Laboratory, Fort Eustis, Virginia, February 1975, AD A007245.

3. OH-6            Observation
4. OH-58          Observation
5. CH-47          Cargo
6. CH-54          Heavy Lift

Repair, as defined by the Army, was to include all actions requiring some disassembly of the component, exclusive of its removal from and installation into the aircraft. As such, it excluded repair tasks involving only an adjustment or alignment (tightening loose hardware, for example) and repair tasks in the nature of rework, such as corrosion treatment and repainting. It also excluded actions involving the complete rebuilding or overhaul of the component. Component repair tasks were to be evaluated at the three levels of maintenance below Depot:

1. Organizational
2. Direct Support
3. General Support

The Army required that the significantly occurring repair actions on each component be analyzed to identify the meaningful elements of the repair task and the percentage of repair time attributable to each element. Task elements were to include:

1. Fault Isolation
2. Inspection (In-process and Final)
3. Repair (Disassembly and Reassembly)
4. Adjustment, Alignment, Tracking, etc.
5. Servicing, Lubrication, etc.

Factors found to be contributing to the time required for repair were also to be identified.

Upon completion of the repair task analysis and problem identification, recommendations for improving the design of future aircraft were to be developed. These were to include, as appropriate, solutions available through improved applications of current technology, as well as new engineering concepts and principles. Deficiencies for which the study of new design concepts was recommended were to be ranked in terms of:

1. Improvement potential
2. The probability that an acceptable concept could be developed
3. The estimated cost (in time and manpower) required to develop the concept

On the basis of this ranking, the Army selected design concepts to be investigated in the final task of the study. Insofar as possible, concepts were to be directed toward the design of generic components and future aircraft, rather than toward specific problems with present-day aircraft and components.

#### TECHNICAL APPROACH

The study was conducted in two phases: Phase I was devoted to assessing repair problems in the field and to associating these problems with deficiencies in component design. Field surveys were conducted to gather data for the study. The collected data was analyzed to single out the significantly occurring repair actions, to identify problems in design, and to classify these problems for further study. After completing the problem analysis task and documenting the results, solutions available through applications of current design technology were identified. Problems in component repair showing potential for improvement via design study were listed, ranked and submitted for Army approval.

Phase II of the program, which comprised the major contractual effort, was devoted to a study of the six most promising problem areas selected by the Army. The Phase II effort initially involved an exploratory period during which a number of candidates were developed for each of the six problem areas. Those appearing to offer the most improvement potential were developed more completely and documented. The final task of Phase II involved an engineering critique in which the effect of each concept on maintenance, reliability, stress, weight and cost was considered.

#### ORGANIZATION OF THE REPORT

The first section of the report describes the study guidelines and methods of analysis. A summary of the major results and conclusions follows. The main body of the report is organized into nine sections, each covering a generic parts group found to be significant from the standpoint of the number of man-hours it consumes in repair and/or the number of repair problems reported by the Army personnel in the field. Each of these sections reviews the collected repair time data and the comments received during the field surveys. Recommended

improvements falling within the definition of current technology solutions are integrated with the discussion of repair problems. For those generic parts groups selected for study in Phase II, a discussion of design concepts completes the section. Conclusions and recommendations are made at the end of the report. An appendix presents the complete tabulated results of the field surveys.

## STUDY METHODS

### PROBLEM IDENTIFICATION AND ANALYSIS

Most of the effort in Phase I was devoted to identifying and assessing repair problems in the field and associating these problems with deficiencies in component design. Field surveys were conducted to gather data for the study. The collected data was analyzed to single out the significantly occurring repair actions, to identify problems in design, and to classify these problems for further study.

### LEVEL OF REPAIR ANALYSIS

Preparatory to making the field surveys, research was conducted to determine the types of repairs authorized for each component and the levels of maintenance at which repair is permitted. The first step was to review the Maintenance Allocation Chart (MAC) for the aircraft to determine the level of maintenance performing general repair of each component. Because the MAC charts do not specifically identify the types of repairs allowed, it was necessary to consult other references for this information.

The maintenance manuals for the aircraft (-20, -34, -35) were researched to locate instructions for repair. The presence of repair instructions in the manual was taken to indicate that the repair was, or could be, performed at that level of maintenance. (It was learned, subsequently, that this is not always the case.) When instructions for repair were located, the pages of the manual were reproduced, along with relevant figures, and filed in a data book for that aircraft. This data, properly indexed and highlighted, was used as a reference source during the field interviews, avoiding the need to refer to the manuals when information was needed.

The final task in preparation for the field surveys was to record in the survey forms (shown and discussed in the next section) each repair task, identified via the data search, and its level of maintenance. Thus, at the start of each survey, the interviewer was prepared with a list of repair tasks to be discussed, by aircraft model and component, and had available to him the necessary reference material.

### FIELD SURVEYS

Four Army maintenance field activities, performing Organizational, D. S. and G. S. maintenance on the six helicopter models, were visited. Table 1 lists the maintenance units surveyed and the aircraft and maintenance levels covered.

TABLE 1. FIELD SURVEY SCHEDULE

Dates	Location	Unit	Model	Maint. Levels	Subsystem	No. of Persons Interviewed
May 5-9	Ft. Eustis, Virginia	AMTD, 2nd Staff and Faculty Co.	OH-6 OH-58 CH-47	ORG/ D. S.	Rotors Power train Electrical	5
		355th Aviation Co.	CH-54	ORG/ D. S.	Rotors Power train Electrical A. P. P.	1
		A/C Repair Section Consolidated Maint. Office	OH-6 OH-58 CH-47	ORG/ D. S.		5
June 2	Ft. Sill, Okla.	273rd Aviation Co.	CH-54	D. S./ G. S.	Rotors Power train Electrical A. P. P.	3
June 3-5	Ft. Hood, Texas	"C" Co., 34th Supt. 6th ACCB	UH-1 AH-1 CH-47	ORG/ D. S.	Rotors Power train Electrical Hydraulics A. P. P.	6
		"D" Co., 34th Supt 6th ACCB	UH-1 AH-1	ORG/ D. S.	Rotors Power train Electrical Hydraulics A. P. P.	4
		528th Transp. Co., 15th Support Brigade	UH-1 AH-1 CH-47	G. S.	Rotors Power train Electrical Hydraulics	6
July 8-10	Ft. Campbell, Kentucky	507th Transp. Co., 5th Transp. Bn.	UH-1 AH-1 OH-58 CH-47	G. S.	Rotors Power train Electrical Hydraulics A. P. P.	5
		"A" Co., 5th Transp. Bn.	UH-1 AH-1 OH-58 CH-47	ORG/ D. S.	Rotors Power train Electrical A. P. P.	6
		"B" Co., 5th Transp. Bn.	UH-1 AH-1 OH-58 CH-47	ORG/ D. S.	Rotors Power train Electrical Hydraulics	3

Ten separate maintenance organizations were visited and forty-four maintenance personnel were interviewed. Each aircraft was surveyed at least twice. Twelve days were spent in the field conducting the surveys.

#### FIELD SURVEY METHOD

It was requested that each interview session be attended by two or more senior level maintenance people who were presently working as mechanics or line supervisors. The desire to have at least two people present at the interview came from the recognition that most of the data being sought would be in the nature of estimates or opinions. Having more than one person responding to questions enabled the interviewer to average estimates or to ask that a question be reconsidered when responses differed greatly. Often, when differences in opinion did arise, the people being interviewed would discuss the task and, in the process of discussion, refresh faulty memory or correct mistaken judgements to arrive at a response reasonable to both.

While it was not always possible to obtain all senior level people for the interviews, at least one attended each interview. Although his presence would sometimes cause the less experienced people attending the session to be cautious with their responses, it tended also to balance the responses and provide greater confidence in the estimates being given. Actually, the opinions of junior level people often added valuably to the interview. This was particularly true during that part of each interview when the respondents were asked to express opinions on problems in design they felt contributed to making a repair task difficult. Frequently, the more experienced and proficient mechanic, having lived with a poor design for many years, would be less inclined to regard it as a problem than one who had only recently been exposed to it. (This will be commented upon further in the discussion of the field survey results.)

The final criterion for selecting maintenance people for the interview, that they be working mechanics or line supervisors, was established so that administrators, not recently exposed to maintenance problems directly, would not be included. It was felt that the best results would be obtained from people who were currently engaged in maintenance work.

Figure 1 is a sample of the form used to record data for the field interviews. As mentioned earlier, the repair tasks authorized for each component, as derived from review of the manuals, were listed on the form in preparation for each survey.

COMPONENT: MAIN ROTOR HEAD MODEL: UH-1 LOCATION: 3 - Hood 4 - Campbell

REPAIR TASK	LOCATION	MAINT LEVEL	RATE OF OCCUR.	ON/OFF ACFT.	CREW SIZE	DISASS. & REASS.	FAULT ISOL.	INSPECT		ADJUST. ALIGN. TRACK, ETC.	DRAIN, SERVICE, LUBE	TOTAL TASK
								IN-PROC./FINAL				
1. Replace Grip Seals	3	DS	66.8	OFF	2	960	-	150	105	60	1217	
	4	GS	75.8	OFF	2	600	-	120	150	30	900	
2. Replace Trunnion Reservoir	3	ORG	33.4	ON	1	30	1	2	-	5	38	
	4											
3. Replace Grip Reservoir	3	ORG	16.7	ON	1	30	1	2	-	15	48	
	4											
4. Replace Grip Res. O-Rings	3	ORG	8.4	ON	1	30	1	2	-	15	48	
	4	DS	8.4	ON	1	10	1	4	-	5	20	
5. Replace Trunnion Res. O-Rings	3	ORG	8.4	ON	1	30	1	2	-	5	38	
	4	DS	6.0	ON	1	30	1	5	-	5	41	

Figure 1. Sample field survey form.

The first step of each interview was to review the list of repair tasks and to obtain confirmation that these tasks were indeed being performed. As later discussion will bring out, a surprising amount of disagreement was found between the repairs authorized by the MAC charts and technical manuals and the work actually being done in the field. Tasks were deleted from or added to the list, based on the repair work being performed at that activity.

The interviewer then proceeded through the list of tasks, asking for estimates of repair frequency and time for each task. In formulating the interview procedure, considerable thought had been given to devising a way for maintenance people, who are not accustomed to thinking in statistical terms, to make reasonable estimates of repair frequency. (Field data does not provide information this specific.) It was desired, ultimately, to obtain these estimates in terms of aircraft flight-hours, but it was judged to be impractical to solicit such rates directly from maintenance people who, ordinarily, are not required to relate the tasks they perform to the hours flown by the aircraft they maintain. Instead, it was asked that the interviewees estimate the number of times that they personally, or the group they supervised, had performed a given task in the last year. It was found that maintenance people were able to estimate in these terms and that, when two or more people were asked for the same estimate, good agreement was usually obtained.

Before concluding, the interviewer asked for data on numbers of aircraft being supported by that maintenance organization and the average monthly utilization of those aircraft over the past year. Information on the numbers of aircraft was readily available locally, as was utilization data, in most cases. In those few instances where utilization data was not available locally, fleet-wide averages obtained from AVSCOM published data<sup>3</sup> was used. (The method used to translate per year repair task frequency to a flight-hour basis is described later in this section of this report.

The next step of the interview requested of the respondents estimates of the averagetime required for the performance of

3. EXECUTIVE SUMMARY REPORT, CH-47A ASSESSMENT AND COMPARATIVE FLEET EVALUATIONS, USAAVSCOM Technical Report 74-45, U. S. Army Aviation Systems Command, St. Louis, Mo., November 1974.

each repair task. The average crew size was estimated first, taking into account the fractional participation of crew members. The place of performance, on or off aircraft, was noted next. The time to perform each of the following task elements was then estimated:

1. Fault isolate
2. Inspect (in-process and final)
3. Repair (disassemble and reassemble)
4. Adjust, align, track, balance, etc.
5. Drain, service, lube, etc.

Guidance in the interpretation of task elements and the time attributable to each element was given by the interviewer at the start of the interview. It was explained that the time estimates were to include productive maintenance time only, i.e., to exclude such factors as administrative and supply delays, lost time, record keeping, etc. Time estimates were given for each of the five task elements individually, expressed in minutes or hours, whichever the respondent seemed most comfortable with. After estimates were made for all five task elements, they were summed and the respondent was asked to judge the reasonableness of the total task time. Adjustments were made at this point when the total time appeared too high or too low.

When all of the numerical data (frequency and time estimates) had been obtained for all of the listed repair tasks on a component, the interviewer solicited comments on design deficiencies thought to have contributed to the time or difficulty of repair. Each of the repair tasks was considered in order, and the interviewee was asked for comments, particularly, whenever one of the task elements had a very large time estimate associated with it. (As the next section of this report will discuss, maintenance people frequently would not recognize or acknowledge the presence of a design problem, even when inordinate difficulty was experienced with a repair task.)

#### DATA CORRELATION AND ANALYSIS

Data collected from the field surveys, a sample of which was shown in Figure 1, was correlated and analyzed. The first step of the analysis converted repair frequency estimates, obtained in terms of number of repair actions per year, to a common base:

actions per 10,000 flight-hours. This was done with the following calculation:

$$\text{RATE} = \frac{(10,000) (\text{Repairs/Year})}{(\text{No. of Aircraft}) (\text{Flight-Hours per Month}) (12)}$$

Information on fleet size and aircraft utilization was obtained from local records or AVSCOM-published statistics, as explained earlier. The rates obtained from two or more maintenance organizations were then averaged to obtain an overall rate for each repair task. A simple arithmetic average was used, rather than attempting to weigh the rates on the basis of relative fleet size or hours flown, since there was no way of ascertaining the relative accuracy of the estimates, and any weighting scheme would tend to assign greater importance to some estimates than to others.

The next step was to convert time repair estimates to a common base - man-hours (some estimates had been given in terms of man-minutes) - and to average the times for the two or more maintenance organizations from which estimates had been obtained. Again, a simple arithmetic average was used. Averages were also calculated for each of the five task elements and expressed on the basis of percentage of total task. When all of the data was correlated, tables were prepared, listing all of the repair tasks on a component, and the average frequency, man-hours and percentage of work for each task element.

For each component, a total repair frequency was obtained by adding the rates of occurrence (frequency) of all of the repair tasks on that component. A repair task was considered to be "significantly occurring" if its rate of occurrence comprised 5% or more of the total rate of repair on that component. All of the significantly occurring repair actions on each component, as derived from the foregoing analysis, are presented in tables in Appendix A.

#### CLASSIFICATION OF REPAIR PROBLEMS

The next requirement of Phase I was to identify, on the basis of the collected data, deficiencies in design that make repair of some components difficult and time-consuming. Before identifying design deficiencies, however, it was necessary to ascertain where problems in repair, of some significance, are being experienced. While the time to perform a repair provides some indication of its difficulty, and perhaps the presence of a problem, time alone cannot be used as the criteria. Some types of repair, by their nature, take more time than others. In order to determine where component design might be contributing

to problems in repair, three factors were considered: (1) the frequency and time to accomplish each task; (2) the comments that people in the field had concerning difficulties they experienced in performing the task; and (3) the maintainability engineer's own observations, based on the field surveys and in-house analysis of data.

#### ANALYSIS OF CURRENT TECHNOLOGY SOLUTIONS

The analysis of current technology solutions involved two areas of effort: (1) identifying deficiencies in design for which solutions are currently available and (2) identifying candidates for Phase II study. In preparation for these tasks, a literature search for other work in the area of design for repairability was made.

#### LITERATURE SEARCH

A search for literature pertinent to the subject area of this study was conducted using the facilities of the New England Research Application Center at the University of Connecticut. The purpose of the search was to uncover reports of similar work for use primarily in identifying current technology solutions to problems of component repair. Lengthy bibliographies were received as a result of the search but, as suspected, nothing was found which directly related to the subject. No prior work in the area of component repairability, specifically, has apparently been done.

#### IDENTIFICATION OF CURRENT TECHNOLOGY SOLUTIONS

Each of the specific problem areas was reviewed by Kaman's maintainability and design engineering personnel and, where a solution to a problem using current technology was perceived, it was recorded. Some of the repair problems are relatively trivial and their solution simple and obvious. Others are more complex, often involving a combination of several problems. A stated solution may, therefore, correct only one of a number of problems complicating repair of a component. In many cases, a problem pertains uniquely to one model of aircraft; its solution is of no tangible benefit unless future designs of the same type are probable. In the course of this investigation, examples of very good design for repairability were also found. Sometimes the solution to a repair problem on one aircraft was to suggest adoption of a better design already used on another.

#### IDENTIFICATION OF STUDY CANDIDATES

There were two ways of approaching the Phase II work. The Army might elect to study particular types of problems with the repair of helicopter components without attempting to deal with

repairability in an overall sense. If, for example, there was a common problem with the application of sealant to certain types of installations, the Army could request that solutions to the sealant problem be studied. Other problems with the installation might be studied separately, or not at all. With this approach, Phase II would attempt to develop concepts which would improve some aspects of the design of that installation, but would not pursue a totally new design.

The other approach was to look at the hardware installations causing the greatest consumption of repair man-hours in the field and to work toward the development of design concepts that would improve the overall repairability of these installations in future aircraft, correcting, in the process, as many of the current-day problems with these installations as possible. All of the problems with an installation, perhaps even some significant ones, might not be solved, but an attempt would be made to improve the general repairability of the installation. This approach was viewed as the better one since it gave the designer the freedom to explore innovative new approaches to design without the constraints that are imposed when attempting to improve upon only one aspect of a current design. The single best measure for selecting candidates for study in Phase II was judged to be the aggregate number of man-hours expended on various types of repairs across the entire Army helicopter fleet, and this was the basis used.

#### RANKING OF STUDY CANDIDATES

Recommended design study projects were drawn from the list of high repair man-hour consumers. Each was analyzed to determine an investment-to-benefit ratio for each candidate, which was used to rank its relative merit for study. Candidates with the highest potential payoff for the required investment in study time were recommended for analysis ahead of those for which a smaller payoff was predicted. This tended to ensure the most productive utilization of the study effort. Maintainability engineering and design personnel jointly conducted the evaluation and ranking.

Three factors, all defined on a scale of high, low or moderate, were included in the ranking of study candidates:

1. Improvement potential
2. Probability of developing a successful solution
3. Estimated cost (in time and manpower) of developing an improvement.

## DESIGN STUDY

The Phase II design study work represents the major effort of the program. Design studies were conducted in six basic problem areas. One or more concepts were explored in each area.

### DESIGN STUDY METHOD

Each of the design study projects followed a similar pattern of development, beginning with the discussion of various technical approaches. Maintainability and design personnel considered various alternatives and selected the approach that appeared to offer most promise. At this point, study time was allocated to each project, based on the amount of work needed to define the concept adequately and the expected value of that concept relative to the others to be studied. The allocation of study time thus tended to favor simple, highly promising concepts over those of a more complex nature.

The design projects were assigned to experienced design people in the respective system area: rotors, drives, hydraulics, etc. As the concepts were being studied, various engineering support groups, such as Stress and Weights, were consulted as questions or problems in these areas arose. Since the work was not to progress beyond a conceptual phase, however, these supporting disciplines were not required to be as intimately involved in the design process as they would in a more formalized effort. Maintainability engineering personnel also followed each study project closely. Frequent visits were made to consult with the designer and ensure that the concept was being developed along the lines previously discussed.

At the completion of each study project, finished sketches were prepared to show the key features of the concept. Engineering notes were prepared to accompany the sketches. At this point, the concept was formally reviewed. Implicit in the review process was the recognition that some concepts for improving the repairability of components would incur penalties of some type. Easing the repair characteristics would, in some instances, work to the detriment of other factors, such as cost or weight. In order to identify these factors, Kaman's engineering support groups reviewed the final concepts and commented upon each from the standpoint of their special area of interest. This final engineering review was undertaken to identify the positive and negative implications of each concept as they relate to maintenance, reliability, stress, weight, cost and performance.

## OVERALL RESULTS AND FINDINGS

### QUALITATIVE SURVEY RESULTS

The field surveys were successful in obtaining the data needed to identify significant problems in repair of the selected components. Overall, the estimates obtained via these interviews, although unsupported by physical records, are believed to reflect adequately the repair tasks consuming the greatest number of man-hours on these components in the field and the elements of these tasks causing the most difficulty. Because data sampling took place at two or more locations for each aircraft, and a large number of people with varying backgrounds and experience were interviewed, separately and in groups, a good cross section of opinion was obtained. In many respects, data obtained via properly structured and controlled interviews, such as these, are more meaningful and more useful than data obtained via the very general, mass data collection systems.

### SCOPE OF FIELD REPAIR

Several interesting observations concerning the scope of component repair in the field and the man-hours it consumes were made in the process of conducting the field surveys. First, the surveys confirmed that extensive repair of helicopter dynamic components is not being done in the field, even at the General Support level. Most of the repairs short of Depot involve very limited disassembly, primarily the replacement of readily removable parts, such as lip seals and sight glasses. The repair work that is being done, however, though usually not extensive or complex, is often repetitive and wasteful of maintenance resources. Nuisance-type problems contribute greatly to the repair workload.

There exists, at many of the maintenance organizations visited, a wide disparity between the repair tasks authorized by official Army publications and those actually being performed. Most often, fewer tasks are performed than are authorized. When asked for reasons why some types of repair tasks were not being performed, maintenance people would generally have no explanation, except that requests for such work were not being received, primarily because those kinds of failures were not occurring. In the case where no repair of a component was being done at all, some generators and hydraulic actuators for example, the reason was usually attributed to lack of personnel skills or maintenance resources. Sometimes, maintenance people were not even aware that they were authorized to accomplish some types of repairs.

Some variations are found among maintenance organizations supporting the same aircraft with respect to the type of repair work being done and the level of maintenance at which it is performed. Occasionally, it was learned that a repair task performed on the aircraft at one base is performed off the aircraft at another, local policy and practice being the only apparent reason.

As said, the situation most frequently encountered was the absence of some kinds of repair work at a given maintenance base; the repairs not being made were usually the same from base to base. Sometimes, a maintenance organization would elect to perform repairs not specifically authorized to them, again based solely on local policy, originally instituted perhaps because of an unusually high failure rate with a particular part, or a shortage of replacement components.

#### EFFECT OF LOCAL POLICIES AND PRACTICES

The maintenance level assigned to perform a given type of repair was also found to vary; a repair being D. S. level at one location and G. S. level at another, for example. On occasion, local policy significantly affected the scope of work performed, as in the case of one maintenance organization who labored through the difficult and very time-consuming task of removing a gearbox from the aircraft in order to replace an output seal that every other maintenance organization replaced quite easily on the aircraft (as permitted by the tech manual) in a fraction of the time. Their explanation for doing this added work was that the gearbox was frequently in need of other repairs which could best be accomplished at the same time off the aircraft.

Somewhat analogous to this example, is the variation in the amount of work performed to accomplish some types of repair. A case in point involves G. S. level repair of starter-generators. At the first of two maintenance organizations surveyed, typical repairs of the starter-generator were said to consume under 2 man-hours, on an average. These same repairs averaged nearly 20 man-hours at the second organization, a ratio of approximately ten to one. The difference in repair time was found to result from variations in basic operating procedure. The first organization repaired only the reported fault and performed a short 1-hour check of the starter-generator, on a vari-drive, after repair. The second organization thoroughly tested the unit upon receipt and made any repairs needed to put it in peak running condition. Thereafter, the unit was run for 8 full hours on the vari-drive to check its performance, the time, incidentally, charged to repair. Therefore, for a given repair of the starter-generator, replacing faulty capacitors, for example, one organization made only that repair, while the other essentially reconditioned the entire unit. In cases such as these, comparing repair times is not meaningful.

### QUALITY OF THE ESTIMATES

Most of the people interviewed were able to make estimates of repair frequency and time that were consistent with the guidelines explained to them. When two or more people were interviewed together, good agreement between them was usually obtained. A few people did experience some difficulty with these estimates, however, especially estimating the number of times specific repair tasks had been performed over the last year. When this happened, the interviewer would assist the person by asking him to simply rank each of the repair tasks on a component in descending order of occurrence, which he was usually able to do. Then, during the course of the interview, the person would, voluntarily or after some prompting, make a frequency estimate for one of the tasks being discussed. Having made one of the required estimates, he would sometimes acquire enough confidence to make the remaining ones. In those few cases where estimates could not be obtained, or were suspected of being erroneous, independent estimates were developed by the interviewer after returning from the survey, using data derived from other interviews.

For the majority of the repair tasks covered by the surveys, frequency and repair time estimates obtained from two or more sources agreed quite closely. (The interviewer was careful not to disclose the results of other surveys or to encourage responses on the basis of those previously received.) In some cases, estimates from two sources were found to vary widely. Differences in estimates of repair time could often be traced to local policy or procedure, as in the case of the starter-generator repairs referred to earlier. Differences in repair frequency estimates were often laid to operational and climatic conditions locally, e.g., a higher incidence of seal deterioration in the sandy environment of Fort Hood. At times, no reasonable explanations could be found for the variation between estimates, and data averaging was relied upon to mitigate its effect.

### COMMENTS ON DESIGN PROBLEMS

More difficult to most people than estimating repair times and frequency, however, was the request for comments on deficiencies in design of the components they were maintaining. It was found that people seldom view everyday tasks as problems, even when they are inordinately difficult and time-consuming. A problem arises only when the unexpected happens; e.g., a stud shears or a seal lodges in its retainer. Whatever difficulty is experienced with the task routinely is considered normal and seldom is poor design considered at fault. Most people, when asked about design problems, would cite poor reliability, even though it was explained that repairability, not reliability, was this project's specific concern. If excessive man-hours were being

expended on repair, most believed that it was due to the component's unreliability and not the difficulty of making the repair; although few had ever thought about it from that standpoint.

Many worthwhile comments were received during the course of the surveys, however. Occasionally, the same comment or complaint was received from everyone interviewed on a particular subject. More often, the comment came from just one person but, since it was only the more astute and observant maintenance people who commented at all, this was not unexpected. Widespread complaints were not considered requisite to identifying a design problem.

QUANTITATIVE SURVEY RESULTS

Six helicopter models and forty-six separate components were analyzed. With the exception of the OH-6 helicopter, which is presently being phased out of regular Army units, the survey produced good response. Table 2 shows the mix of components

TABLE 2. FIELD SURVEY RESPONSE						
	OH-58	OH-6	UH-1	AH-1	CH-47	CH-54
Main Transmission	(X)	X	(X)	(X)		(X)
Aft Transmission					(X)	
Forward Transmission					(X)	
Combining Transmission					(X)	
Intermediate Gearbox			(X)	(X)		(X)
Tail Rotor Gearbox	(X)	(X)	(X)	(X)	(X)	(X)
Main Rotor Hub	(X)	(X)	(X)	(X)	(X)	(X)
Tail Rotor Hub	(X)	X	(X)	(X)		(X)
Swashplate and Support Assy.	(X)	X	(X)	(X)	(X)	(X)
Hydraulic Servo Actuator	(X)		(X)	(X)	X	(X)
Generator/Starter-Generator	(X)	X	(X)	(X)	X	(X)
APP/APU					(X)	(X)
X	Applicable Component		(O) Survey Data Obtained			

by helicopter model, indicating those on which data was collected. In nearly every case, data was obtained from at least two, and occasionally three, separate sources.

Using the data-averaging technique described in the section of the report on methods of analysis, and recent statistics on fleet populations and average utilization,<sup>3</sup> the man-hours expended on field repair of the nine generic types of components, fleet-wide per 10,000 aircraft flight hours, have been estimated. To obtain the fleet-wide averages, repair time data on each model was weighted on the basis of that model's contribution to total fleet hours flown each year. Table 3 gives the fleet size and utilization statistics, and the weighting factors used.

TABLE 3. FLEET SIZE AND UTILIZATION DATA AND REPAIR TIME WEIGHTING FACTORS			
Model	Average Quantity Operational	Average Monthly Utilization	Weighting Factor <sup>(1)</sup>
OH-58	1557	16.1	30.1
OH-6	267	10.8	3.5
UH-1	2195	22.0	58.0
AH-1	583	9.9	6.9
CH-47	284	13.0	4.4
CH-54	57	11.3	0.8
(1) Flt-Hrs/Year x 10 <sup>-4</sup>			
Source: Reference 3			

3. EXECUTIVE SUMMARY REPORT, CH-47A ASSESSMENT AND COMPARATIVE FLEET EVALUATIONS, USAAVSCOM Technical Report 74-46, U. S. Army Aviation Systems Command, St. Louis, Mo., November 1974.

Table 4 gives the estimated man-hour cost of field repair by component group and level of maintenance. The man-hour rates

Rank		Generic Component Group		Man-Hours/10,000 Flt-Hrs				
				On-Aircraft		Off-Aircraft		Total
				Org.	D.S.	D.S.	G.S.	
1	Main Rotor Head	30	45	967		1042		
2	Generator/Starter-Generator			160	193	353		
3	Hydraulic Actuator		78		246	324		
4	Main (Fwd/Aft/Combining) Transmission	39	148	101		288		
5	Tail Rotor Gearbox	13	42	93		148		
6	Intermediate Gearbox	12	2	84		98		
7	Tail Rotor Head	3		75		78		
8	Swashplate & Support Assembly	6	10	60		76		
9	Auxiliary Power Unit	1		2		3		

include only the significantly occurring repair actions on each component, i.e., those contributing 5% or more of the total repair actions as determined from the survey data. As shown, on-aircraft repair accounts for less than 20% of the man-hours expended. Direct Support maintenance does most of the repair work, both on and off the aircraft. Only two types of components, hydraulic actuators and generators, are being repaired on a regular basis by General Support level activities. Repair of main rotor heads consumes over 40% of the total man-hours reported for repair of major components.

Overall, field repair of major helicopter components, as determined by the surveys, consumes approximately 1/4 man-hour per flight-hour, based on the approximate mix of aircraft and flying hours shown earlier. Considering the components for which no data was collected, and the repair actions dropped for failing to meet the criteria of "significantly occurring", the true repair workload on major helicopter components in the

field may be significantly higher. It should be remembered also that the repair time data collected via the survey accounts only for the productive "wrench-turning" time. Lost time, record keeping, administrative functions, etc., add substantially to the total man-hour cost to the Army.

Table 5 is a breakdown of repair man-hours by generic parts

TABLE 5. FLEET-WIDE REPAIR MAN-HOURS BY GENERIC PARTS GROUP						
Rank	Generic Parts Group	Man-Hours/10,000 Flt-Hrs				Total
		On-Aircraft		Off-Aircraft		
		Org.	D.S.	D.S.	G.S.	
1	Rotor Head and Swashplate Seals		40	993		1033
2	Gearbox Lip Seals	14	157	278		449
3	Hydraulic Actuator O-Ring Seals				242	242
4	Generator Brushes			122		122
5	Bushings/Teflon Bearings/Uniball Seats		1	85	4	90
6	Rubber Boots	4	75			79
7	Anti-Friction Bearings			21	49	70
8	Generator Capacitors				66	66
9	Generator Terminal Blocks				52	52
10	Oil Level Sight Glasses	43				43
11	Generator Input Shafts			38	1	39
12	Carbon Seals		34			34
13	Covers/Shields/Liners	4		2	25	31
14	Mechanical Linkages	5	12	1		18
15	Static Seals	12	1			13
16	Oil Filters and Reservoirs	11				11
17	Spherical Bearings and Rodends	6		1		7
18	Mechanical Stops, Pads, Etc.	1	5	1		7
19	Chip Detectors/Switches/Solenoids	1				1

group. By far the largest consumers of repair man-hours are the rotor head and gearbox lip seals (nearly two-thirds of the total). As shown, the majority of these seals are replaced off the aircraft at Direct Support level. Seals, in total, account for nearly three-fourths of the total repair man-hours. Other types of parts are much less frequently involved in repair. The magnitude of seal replacements in the repair of major components is illustrated in the bar chart of Figure 2.

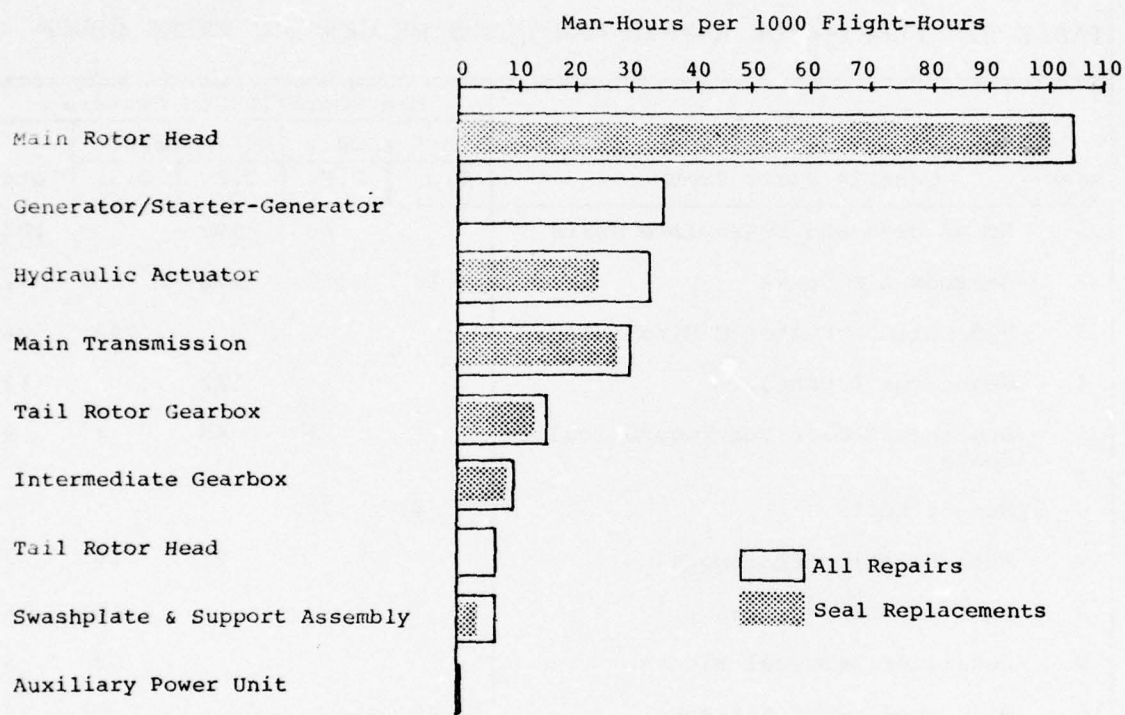

Figure 2. Fleet-wide man-hours expended on seal replacements.

The average man-hours required for repair are ranked for generic parts groups and major component types in Tables 6 and 7, respectively. Main rotor heads and generators require the largest number of man-hours, on an average, to repair. Among the parts groups, gearbox carbon seals and main rotor head lip seals rank high. A number of generator parts also are prominent, due primarily to the lengthy testing these components undergo following repair.

TABLE 6. FLEET-WIDE AVERAGE REPAIR TIME BY  
GENERIC PARTS GROUP

Rank	Generic Parts Group	Average Repair Man-Hours				
		On-Aircraft		Off-Aircraft		Total
		Org.	D.S.	D.S.	G.S.	
1	Carbon Seals		23.4			23.4
2	Rotor Head and Swashplate		6.3	15.9		15.0
3	Generator Capacitors				11.8	11.8
4	Generator Brushes			8.3		8.3
5	Generator Input Shafts			10.7	.8	8.3
6	Generator Terminal Blocks				8.1	8.1
7	Anti-Friction Bearings			3.4	10.5	6.5
8	Mechanical Linkages	3.9	8.2	8.7		6.3
9	Hydraulic Actuator O-Ring Seals				5.8	5.8
10	Covers/Shields/Liners	1.8	.3	2.7	10.4	5.5
11	Bushings/Teflon Bearings/Uniball Seats		6.8	3.3	5.2	3.4
12	Gearbox Lip Seals	4.4	7.2	1.7		2.3
13	Rubber Boots	2.6	1.6			1.6
14	Mechanical Stops, Pads, Etc.	1.1	1.4	6.5		1.5
15	Chip Detectors/Switches/Solenoids	.8	.5			.8
16	Oil Filters and Reservoirs	.7				.7
17	Spherical Bearings and Rodends	.6		1.1		.6
18	Oil Level Sight Glasses	.5				.5
19	Static Seals	.3	4.9			.3

TABLE 7. FLEET-WIDE AVERAGE REPAIR TIME BY  
GENERIC COMPONENT GROUP

Rank	Generic Component Group	Average Repair Man-Hours				Total
		On-Aircraft		Off-Aircraft		
		Org.	D.S.	D.S.	G.S.	
1	Main Rotor Head	.8	4.6	17.2		10.2
2	Generator/Starter-Generator	.5		8.8	9.5	9.1
3	Hydraulic Actuator		1.6		7.8	4.1
4	Tail Rotor Head	2.2		3.0		3.0
5	Swashplate & Support Assembly	.6	13.7	4.1		3.0
6	Main (Fwd/Aft/Combining) Trans- mission	.6	11.8	1.6		2.0
7	Auxiliary Power Unit	1.2	.3	2.9		1.7
8	Tail Rotor Gearbox	.4	3.8	1.8		1.6
9	Intermediate Gearbox	.5	5.1	1.6		1.3

## SURVEY RESULTS AND DESIGN STUDY

### GEARBOX AND ROTOR HEAD LIP SEALS

Lip seals are the type of seal most commonly used for oil and grease sealing applications in helicopter transmissions and rotors. They are used in a variety of applications ranging from low-speed oscillating shafts typical of rotor installations to the high-speed input shafts of main transmissions. Most accessory drives also use lip-type seals.

The conventional lip seal consists of a rubber sealing element, molded, or bonded, into a metal shell or case. The seal may have either one or two sealing lips which are kept in contact with the shaft via a garter spring installed in a groove in the seal. (Some low-speed applications involving highly viscous fluids do not employ the spring.) Retention of the seal in the housing is usually maintained by the press fit of the metal shell in the housing bore. One type has an integral flange that is bolted to the housing. A brushable sealer is usually applied to the metal shell to attain a good static seal.

### REPAIR TIME DATA AND FIELD-REPORTED PROBLEMS

Lip seal replacements are the most frequently performed repair of the components covered by the study. All lip seal installations are quite similar with respect to seal-to-housing interface. However, access to particular installations can vary significantly. Generally, the degree of component disassembly required for seal change is greatest with rotor heads and swash-plates and somewhat less with input/output seals in gearboxes.

#### Gearbox Input and Output Seals

All transmissions and gearboxes in the six models of Army helicopters use lip seals at their inputs except the CH-54, which incorporates carbon seals. Replacement time data, collected during the field interviews, is presented in Table 8. No data appears for the OH-6 because it is currently being phased-out of regular Army units, and the people interviewed had very little experience with the aircraft.

Input seal replacement on three gearboxes of the UH-1/AH-1 and one gearbox of the CH-54 requires removal of the gearbox or quill (UH-1/AH-1 main transmission). Most mechanics believe that it is unnecessary to remove the UH-1/AH-1 intermediate and tail rotor gearboxes for replacement of input seals, but do so because of technical manual instructions. The CH-54 intermediate gearbox must be removed because it mounts to the aft side of the tail boom fin, prohibiting access to the input seal.

TABLE 8. REPAIR TIME DATA, GEARBOX INPUT SEALS

Model	Component/Part		Elements of Replacement Task				Component Repl. Time*	
			Total Task Time	Dis-assy. and Assy.	Adjst, Align, Etc.	Drain, Lube, Ser-vice		In-spect and Test
OH-58	Transmission	Hrs.	10.9	10.0		0.3	0.6	
		Pct.		91.7		2.8	5.5	
UH-1	Transmission (Input Quill Assy.)	Hrs.	2.2	2.0			0.2	7.3
		Pct.		90.9			9.1	
AH-1	Transmission (Input Quill Assy.)	Hrs.	2.2	2.0			0.2	6.4
		Pct.		90.9			9.1	
CH-47	Fwd. Transmission	Hrs.	6.6	6.0			0.6	
		Pct.		90.9			9.1	
CH-47	Aft Transmission	Hrs.	6.1	5.4	0.1		0.6	
		Pct.		88.5	1.6		9.8	
CH-47	Combining Transmission	Hrs.	5.3	3.2	1.0	0.3	0.8	
		Pct.		60.4	18.9	5.7	15.1	
UH-1	Intermediate Gearbox	Hrs.	1.6	0.5		1.0	0.1	3.1
		Pct.		31.3		62.5	6.3	
AH-1	Intermediate Gearbox	Hrs.	1.6	0.5		1.0	0.1	2.6
		Pct.		31.3		62.5	6.3	
CH-54	Intermediate Gearbox	Hrs.	3.0	2.0		0.1	0.9	7.1
		Pct.		66.7		3.3	30.0	
UH-1	Tail Rotor Gearbox	Hrs.	1.6	0.5		1.0	0.1	4.9
		Pct.		31.3		62.5	6.3	
AH-1	Tail Rotor Gearbox	Hrs.	1.6	0.5		1.0	0.1	4.8
		Pct.		31.3		62.5	6.3	
OH-58	Tail Rotor Gearbox	Hrs.	3.4	2.5		0.1	0.8	
		Pct.		73.5		2.9	23.5	
CH-54	Tail Rotor Gearbox	Hrs.	5.5	4.5		0.4	0.6	
		Pct.		81.8		7.3	10.9	
Weighted Average		Hrs.	3.3	2.4		0.5	0.4	
		Pct.		72.7	0.0	15.2	12.1	

\* Off-aircraft tasks.

Table 9 provides repair time data on lip seals used at most outputs of transmissions and gearboxes. All of these seals are replaced on-aircraft, except those in UH-1/AH-1 components for the reason just mentioned.

The major complaints with replacement of gearbox input and output seals are concerned mainly with the inability to remove some seals without disassembling other hardware. The input quills of the UH-1 and AH-1 transmissions present particular problems in this regard. Access to input seal hardware is a problem in some cases. Safetying tasks are also reported to be troublesome with some installations. The following specific complaints were received from people in the field.

#### Access Problems (OH-58, UH-1, AH-1, CH-47)

Access to the input seals of the OH-58, UH-1 and AH-1 transmissions is confining and creates an uncomfortable working position for the mechanic. Figure 3 illustrates the problem with the OH-58. It appears unlikely that access can be substantially improved with power trains of this design. Seal installations that might ease the replacement task are among the design concepts discussed later in this section of the report.

Access is a problem when replacing the power take-off shaft seals in the accessory mounting pads of the CH-47 aft transmission. Since many accessories are mounted in a dense pattern (Figure 4) and all work must be accomplished from below, access to the seals on the higher-mounted accessories is particularly troublesome and many tasks must be performed by feel alone. The weight of some accessories contributes to the problem (each of the two generators weighs approximately 60 pounds). Access problems of this nature could be alleviated significantly if the seals were made more easily replaceable.

When making an on-aircraft replacement of the output shaft seal in the CH-47 aft transmission, it is difficult to properly orient the seal housing on an offset pattern of attachment studs. The mechanic cannot see the complete pattern of studs due to the proximity of the rotor shaft and has difficulty establishing which of the many studs is offset. A design that might simplify this task uses a dowel pin pressed into the transmission housing, and a loose mating hole in the seal housing and shim stack, to provide positive indexing with a pattern of equally spaced studs.

#### Quill Removal and Installation (UH-1, AH-1)

To replace input seals in the UH-1 and AH-1 transmissions with the newer "super quills" installed, the tight-fitting quill

TABLE 9. REPAIR TIME DATA, GEARBOX OUTPUT SEALS

Model	Component/Part		Elements of Replacement Task					Component Repl. Time*
			Total Task Time	Dis-assy. and Assy.	Adjst, Align, Etc.	Drain Lube Service	In-spect and Test	
UH-1	Transmission (Tail Rotor Drive)	Hrs.	1.2	0.9		0.2	0.1	11.6
		Pct.		75.0		16.7	8.3	
AH-1	Transmission (Tail Rotor Drive)	Hrs.	1.2	0.9		0.2	0.1	11.6
		Pct.		75.0		16.7	8.3	
UH-1	Transmission (Rotor Mast Seal)	Hrs.	0.6	0.5			0.1	10.3
		Pct.		83.3			16.7	
AH-1	Transmission (Rotor Mast Seal)	Hrs.	0.6	0.5			0.1	8.3
		Pct.		83.3			16.7	
CH-47	Fwd. Transmission (Rotor Mast Seal)	Hrs.	19.3	15.9		1.0	2.4	
		Pct.		82.4		5.2	12.4	
CH-47	Aft Transmission (Power Takeoff Seal)	Hrs.	3.1	2.7			0.4	
		Pct.		87.1			12.9	
CH-47	Combining Transmission (Output Drive)	Hrs.	5.3	4.0	0.2	0.2	0.9	
		Pct.		75.5	3.8	3.8	17.0	
CH-54	Transmission (Tail Rotor Takeoff)	Hrs.	6.2	5.5			0.7	
		Pct.		88.1			11.3	
UH-1	Intermediate Gearbox (Tail Rotor Drive)	Hrs.	1.6	0.5		1.0	0.1	3.1
		Pct.		31.3		62.5	6.3	
AH-1	Intermediate Gearbox (Tail Rotor Drive)	Hrs.	1.6	0.5		1.0	0.1	2.6
		Pct.		31.3		62.5	6.3	
CH-54	Intermediate Gearbox (Tail Rotor Drive)	Hrs.	5.1	4.0			1.1	
		Pct.		78.4			21.6	
OH-6	Tail Rotor Gearbox (Tail Rotor Drive)	Hrs.	1.7	1.0		0.1	0.6	
		Pct.		58.8		5.9	35.3	
OH-58	Tail Rotor Gearbox (Tail Rotor Drive)	Hrs.	3.4	2.5		0.1	0.8	
		Pct.		73.5		2.9	23.5	

TABLE 9 - Continued

Model	Component/Part		Elements of Replacement Task					Component Repl. Time
			Total Task Time	Dis-assy. and Assy.	Adjst, Align, Etc.	Drain Lube Service	In-spect and Test	
UH-1	Tail Rotor Gearbox	Hrs. Pct.	2.1 95.2	2.0 95.2			0.1 4.8	4.9
AH-1	Tail Rotor Gearbox	Hrs. Pct.	2.1 95.2	2.0 95.2			0.1 4.8	4.8
CH-54	Tail Rotor Gearbox	Hrs. Pct.	60.0 88.3	53.0 88.3	3.0 5.0		4.0 6.7	
Weighted Average		Hrs. Pct.	3.8 81.6	3.1 81.6	0.1 2.6	0.2 5.3	0.4 10.5	

\* Off-aircraft tasks.

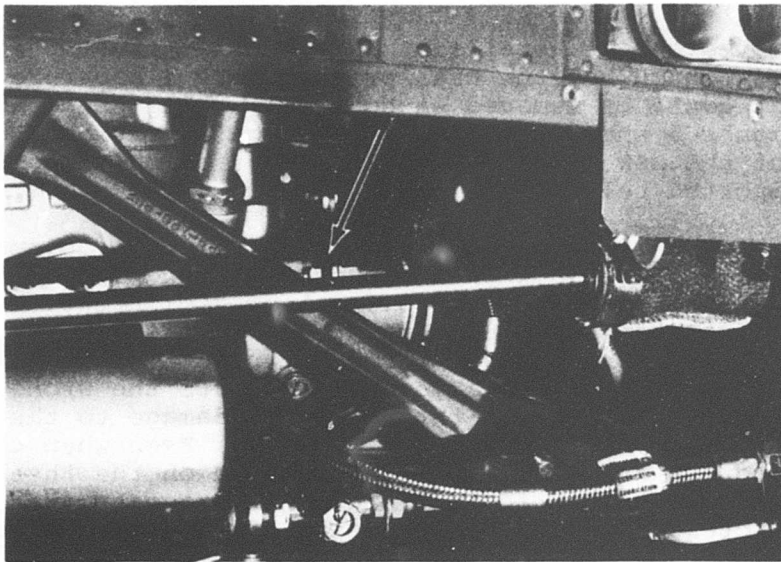

Figure 3. Limited access to transmission input quill, OH-58 helicopter.

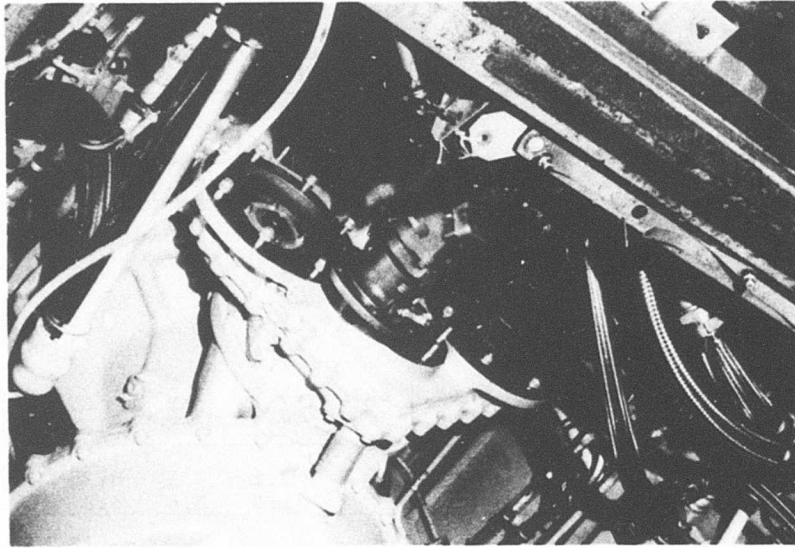
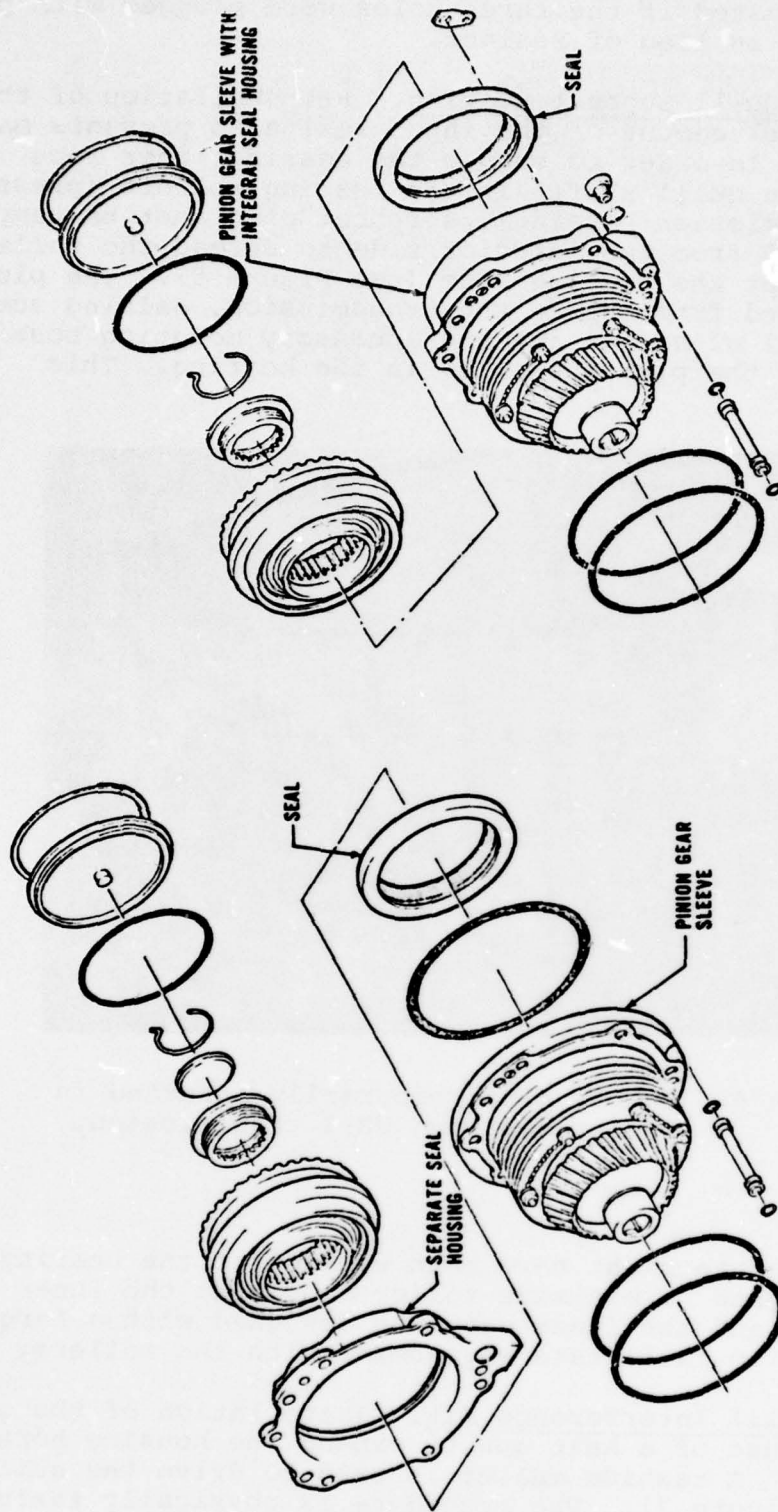

Figure 4. Accessory drive section,  
CH-47 aft transmission.

must be removed and reinstalled. This was not true of the older quills, which had the seal pressed into a separate housing that could be removed without disturbing the quill itself. Figure 5 shows the old and new configurations. The tight fit of the new quill creates a number of maintenance problems, as reported below.

Use of Jackscrews for Quill Removal. One of the problems has to do with the use of jackscrews to overcome the tight fit of the quill during removal. A second set of jackscrews, having the same diameter as those used for the transmission input quill, but a different thread pitch, are used elsewhere in the drive train. Occasionally, a mechanic selects the wrong set of jackscrews, causing cross-threading and damage to the jackscrews and the tapped holes in the housing. Even when the proper jackscrews are used, the load imposed on the thread is often great enough to strip it. Hindsight suggests that one set of jackscrews with a larger thread and greater load capacity than either of the two now in use, should have been specified for all applications. A second problem reported with the use of jackscrews for removal of the transmission input quill is the need to remove sealant from the threaded holes which engage the jackscrews. This tedious and time-consuming task



Superseded Design

New Design

Figure 5. UH-1 transmission input quills.

might be eliminated if the three holes were plugged with plastic cap screws in lieu of sealant.

Engagement of Quill Support Bearing. Reinstallation of the quill after replacement of the input seal also presents major difficulties. In order to engage the bearing inner race (mounted on the quill shaft) in the bearing rollers (pressed into the transmission housing), a rubber plug must be temporarily inserted from the interior side to spread the rollers enough to accept the bearing race (see Figure 5). The plug must be inserted from inside the transmission, gaining access through removal of an oil jet and accessory mounting boss cover. Figure 6 shows the plug installed in the bearing. This

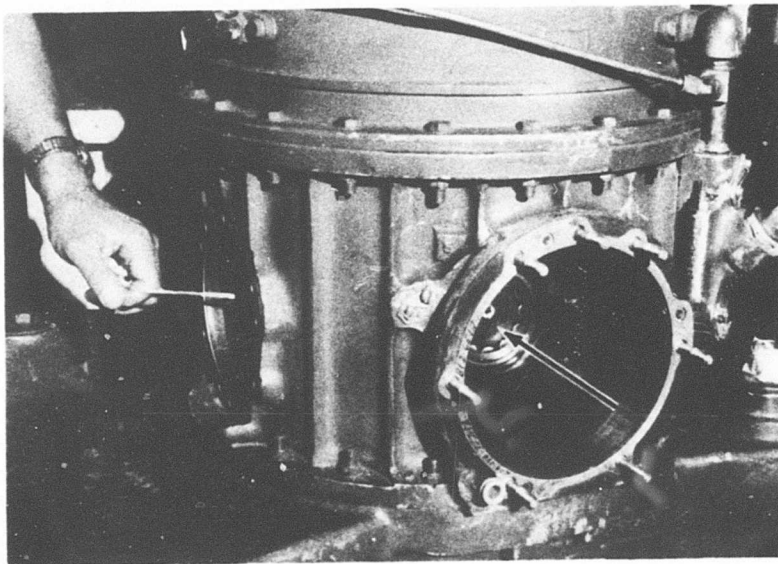

Figure 6. Rubber plug temporarily inserted in roller bearing, UH-1 transmission.

involved procedure might have been avoided if the bearing cage had been designed to minimize roller drop when the inner race is withdrawn, and the inner race was designed with a larger pilot or lead to facilitate engagement with the rollers.

Overcoming Quill Interference Fit. Installation of the quill requires the use of a heat gun to expand the housing bore for installation. A rawhide mallet is used to drive the quill into place (Figure 7). The procedure is physically taxing and

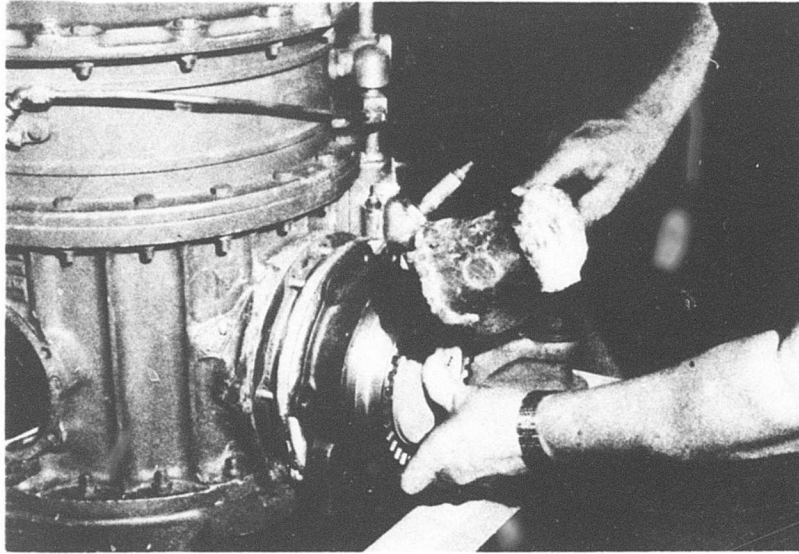

Figure 7. Insertion of input quill,  
UH-1 transmission.

requires an average of 15 to 20 minutes to perform. A possible approach to achieving the required fit of the quill in the bore without the installation problems currently experienced would be to use split cones and tapered diameters, such as those common in propeller installations. Weight and cost would undoubtedly increase with this type of design, however.

#### Seal Housing Fit (CH-47)

To replace the output seal in the CH-47 forward transmission, the seal retainer must be heated in an oven to 121°C prior to insertion of the seal. The retainer is steel and the seal casing is magnesium or aluminum. The very tight fit is specified evidently to insure that some minimum fit is maintained during extreme changes in operating temperature when the two metals expand and contract at different rates. The large diameter of the seal aggravates the situation. Lighter assembly fits might have been possible if the seal casing and seal retainer were both made of aluminum.

## Shim Damage (OH-58)

The input seal on the OH-58 transmission (Figure 8) is pressed

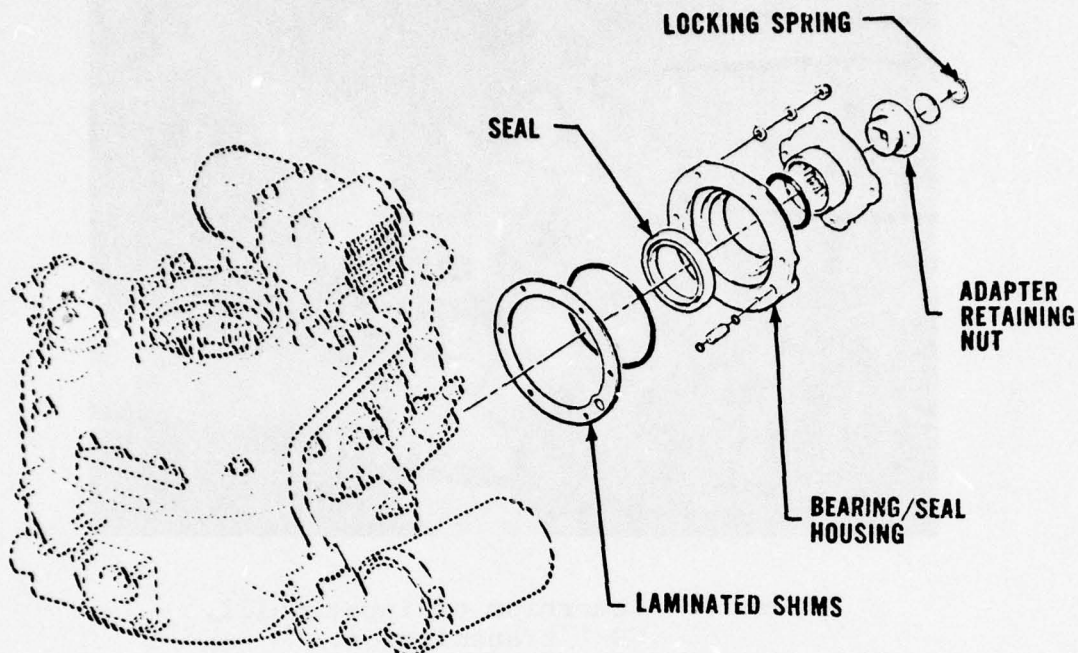

Figure 8. Exploded view of input quill, OH-58 transmission.

into the housing's inside surface, rather than into the outside surface as is done with many other seal installations. Mechanics frequently use a screwdriver to pry the seal housing from the transmission, often damaging the laminated shims sandwiched between the two housings (Figure 9). When this happens, a new shim stack must be drawn from supply and fitted to the installation, a time-consuming process. These problems might have been avoided entirely if the housing were designed to accept the seal from the outside. As an alternative, radial slots, specifically designed to accept a screwdriver blade, might have been incorporated in the faying surface of the seal housing, with the shim stack scalloped in the vicinity of the prying slots.

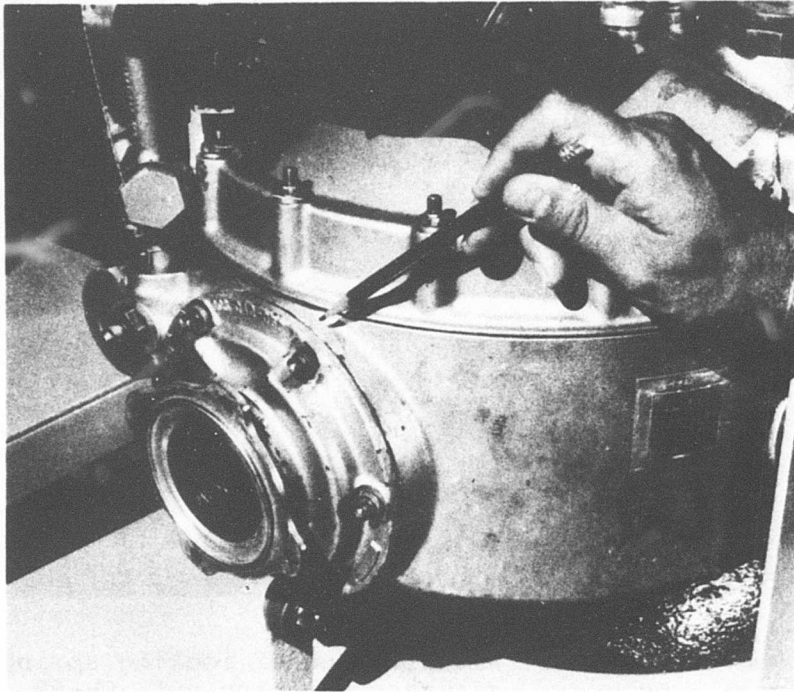

Figure 9. Location of laminated shims behind input bearing/seal housing, OH-58 transmission.

#### Safetying Problems (OH-58, OH-6)

Installation of the seal housing on the OH-58 transmission after replacement of the input seal requires that the spanner-type retaining nut be torqued and safetyed with a locking spring (Figure 10). The nut has a series of radially drilled holes and the mechanic must determine which of the holes aligns with the axial slot in the outside diameter of the input shaft that accepts the locking spring. When this is done on the aircraft, the mechanic, using a flashlight and mirror, probes for the slot with a piece of lockwire. The locking system might have employed the use of serrated nuts and serrated locking rings to simplify the safetying task.

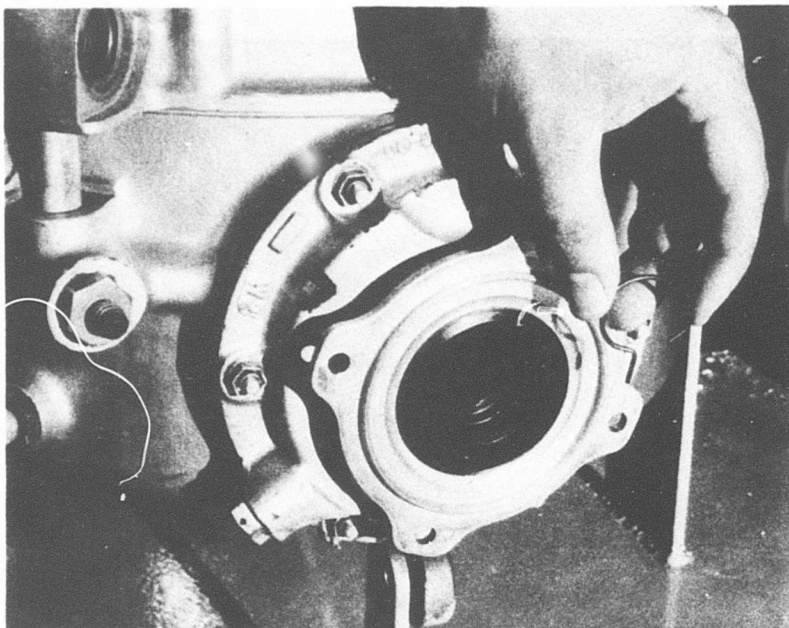

Figure 10. Installation of locking spring in adapter retaining nut, OH-58 transmission.

After replacing the output seal in the OH-6 tail rotor gearbox, it is necessary to lockwire together three cap screws retaining the output cover on the gearbox housing (Figure 11). Access to the screw heads is inhibited by the presence of a rubber boot (Figure 12). A bent-tab washer would require less working space and take less time for the mechanic to install.

#### Unnecessary Assembly Steps (UH-1, AH-1)

Tail rotor take-off seals in the UH-1 and AH-1 transmissions (Figure 13) and input and output seals in the UH-1 and AH-1 intermediate and tail rotor gearboxes are pressed into the exterior side of the bearing retaining nut. Handbook procedures call for removing the retaining nut and pressing the seal from the nut on an arbor press. Many mechanics simplify the task by leaving the nut installed and prying the seal out, using a locally fabricated tool similar to an automobile brake adjusting tool. The new seal is then tapped into place with a mallet. The procedure works well and saves considerable time. The handbook could be modified accordingly and contain instructions for making the seal removal tool.

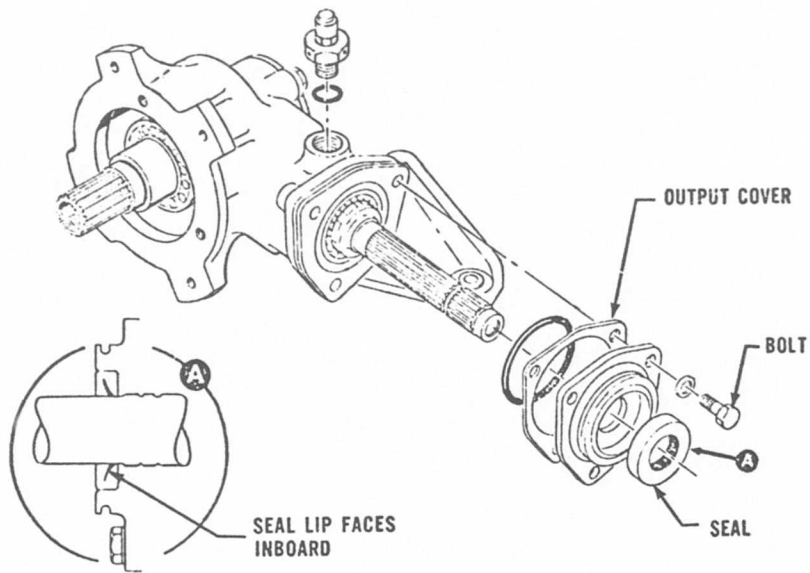

Figure 11. Output seal, OH-6 tail rotor gearbox.

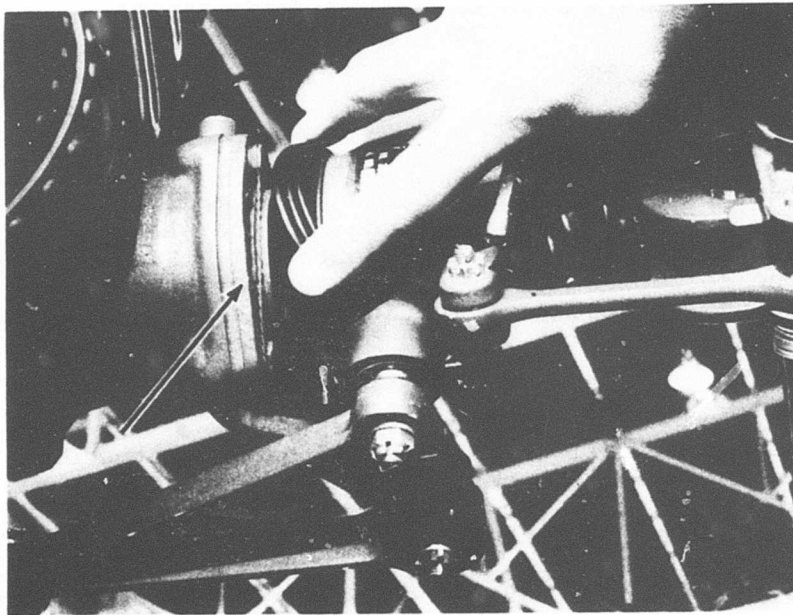

Figure 12. Lockwiring output cover, OH-6 tail rotor gearbox.

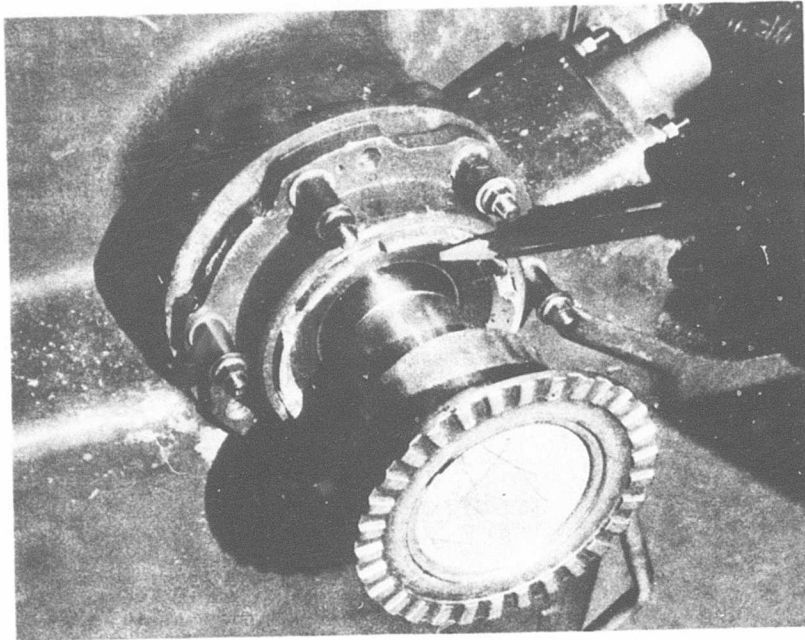

Figure 13. Tail rotor take-off seal,  
UH-1 transmission.

#### Sealant Problem (OH-58)

The input and output seals on the OH-58 tail rotor gearbox use a brushable sealer around the edge of the seal housing faying surface to prevent corrosion (Figure 14). Time is required to apply the sealant and to scrape it off with each removal of the housing. In some applications, this task might be avoided by using a flat gasket in lieu of the sealant.

#### Servicing Time (UH-1, AH-1)

After replacing tail rotor take-off seals in the UH-1 and AH-1 transmissions, it is necessary to service the transmission with oil. This is a two-man job because the filler port is widely separated from the oil level sight glass and one man cannot fill and simultaneously observe the rise in oil level. Indirect reading oil level indicators that could be positioned adjacent to the filler port are among the design concepts explored in the section of the report dealing with sight glass installations.

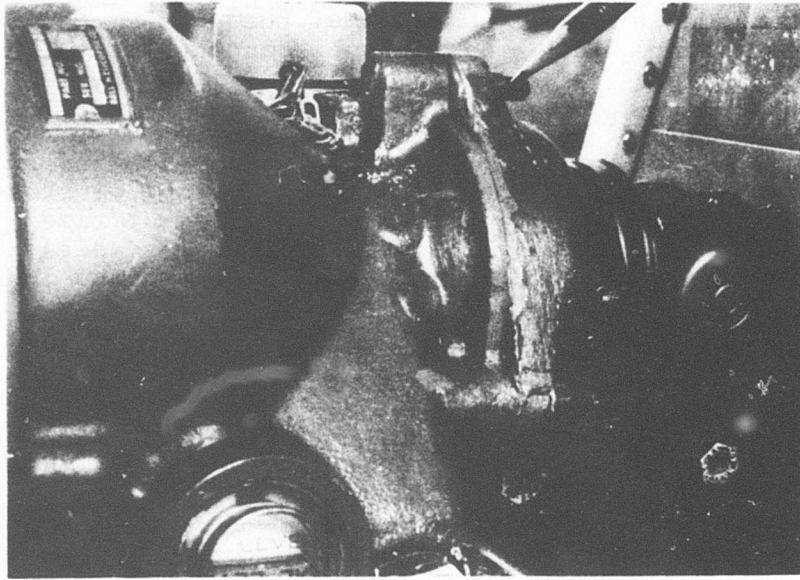

Figure 14. Brushable sealer on output seal housing, OH-58 tail rotor gearbox.

#### Problems With Special Pullers (UH-1, AH-1, CH-54)

A special puller is used to remove the mast bearing as part of the mast seal replacement task on the UH-1 and AH-1 transmissions. The fingers of the puller occasionally distort under load. The problem could be eliminated if the puller were more ruggedly designed. A design concept using grease pressure to overcome the press fit of bearings on shafts is discussed in the section of this report dealing with bearings.

The special puller used to remove the accessory power take-off seals from the CH-54 transmission attaches to the metal shell of the lip seal with three rods. The ends of the rods are tipped with sheet metal screws that engage holes in the metal shell. Frequently, the screws pull out of the shell before the seal is fully extracted. The problem might have been eliminated if four or five rods were used to attach the puller instead of three, thereby reducing the load imposed on any one.

#### Rotor Phasing (CH-47)

After replacing input seals in the CH-47 forward or aft transmissions, it is necessary to check rotor phasing. Because of the configuration of the drive train and the speed reduction

that takes place in the transmissions, the problem cannot be eliminated by simply indexing external connections.

Rotor Head and Swashplate Seals

Lip seals in oil or grease lubricated rotor heads and swashplates have replacement problems similar to some of those reported for lip seals in gearboxes. Replacement times, however, are generally higher because more extensive disassembly is required. Table 10 provides repair time data and indicates

TABLE 10. REPAIR TIME DATA, ROTOR HEAD AND SWASHPLATE SEALS								
Model	Component/Part		Elements of Replacement Task					Component Repl. Time*
			Total Task Time	Dis-assy. and Assy.	Adjst. Align, Etc.	Drain Lube Ser-vice	In-spect and Test	
OH-58	Main Rotor Hub (Inboard Grip Seal)	Hrs.	13.8	8.0	4.8	0.7	0.3	7.4
		Pct.		58.0	34.8	5.1	2.2	
OH-58	Main Rotor Hub (Outboard Grip Seal)	Hrs.	17.0	11.0	4.7	0.8	0.5	7.4
		Pct.		64.7	27.6	4.7	2.9	
UH-1	Main Rotor Hub (Grip Seals)	Hrs.	18.2	13.0	2.2	0.8	2.3	11.1
		Pct.		71.4	12.1	4.4	12.6	
CH-47	Rotor Head (Horiz. Hinge Pin Seal)	Hrs.	21.2	18.0	0.2	1.5	1.5	10.8
		Pct.		84.9	0.9	7.1	7.1	
CH-47	Rotor Head (Vert. Hinge Pin Seal)	Hrs.	6.3	5.3		0.8	0.2	
		Pct.		84.1		12.7	3.2	
CH-47	Rotor Head (Pitch Housing Seal)	Hrs.	12.8	11.5		0.9	0.4	10.8
		Pct.		89.8		7.0	3.1	
UH-1	Swashplate (Upper and Lower Seals)	Hrs.	4.3	3.3	0.4	0.1	0.5	10.0
		Pct.		76.7	9.3	2.3	11.6	
AH-1	Swashplate (Upper and Lower Seals)	Hrs.	4.5	3.6	0.4	0.1	0.4	7.5
		Pct.		80.0	8.9	2.2	8.9	
CH-47	Swashplate (Lower Seal)	Hrs.	3.0	2.6		0.2	0.2	14.1
		Pct.		86.7		6.7	6.7	
Weighted Average		Hrs.	12.4	9.7	0.9	0.9	0.9	
		Pct.		78.2	7.3	7.3	7.3	
* Off-aircraft tasks.								

that all rotor head and swashplate lip seal replacements are off-aircraft actions, except the CH-47 rotor head vertical hinge pin seals. The grip seals in the OH-58 and UH-1 main rotor hubs received the majority of complaints by mechanics in the field.

#### Inaccessible Retaining Nut (OH-58)

To replace grip seals in the OH-58 main rotor head, it is necessary to disconnect the outboard end of the T-T strap from the grip (Figure 15). A pair of nuts threaded onto the long

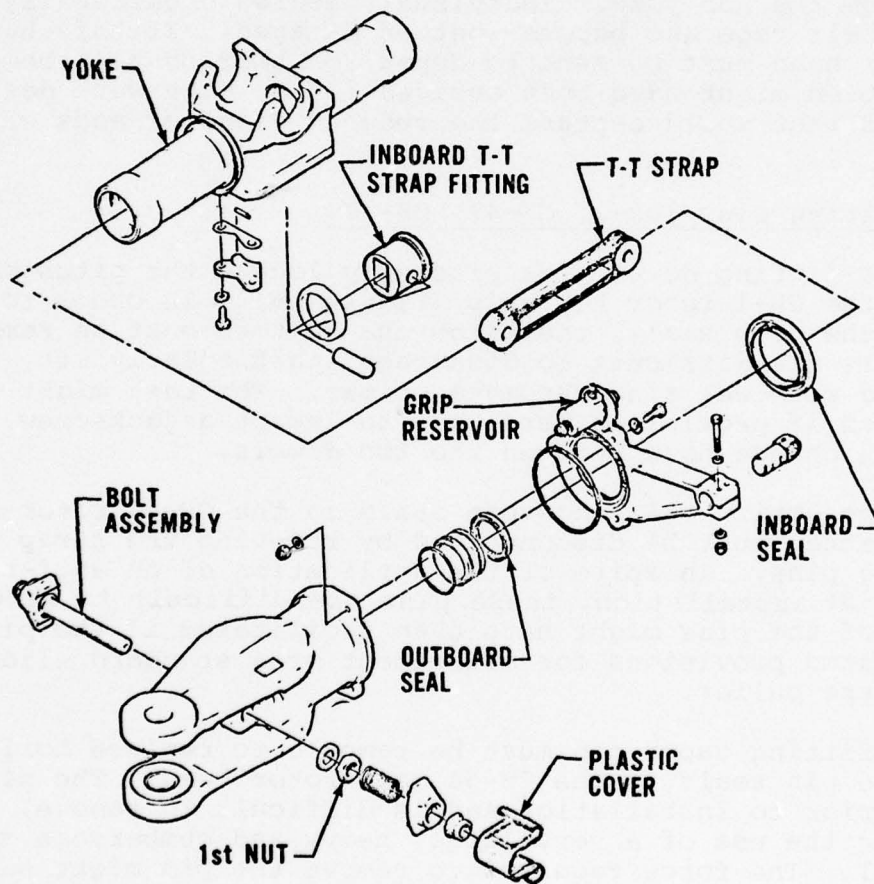

Figure 15. Exploded view, OH-58 main rotor hub.

attaching bolt retain a spring and latch on the bolt. The first nut is 3 inches deep on the bolt when installed. Use of an open-end wrench to remove and install this nut is time-consuming due to the limited space in which to swing the wrench. Sockets of the required depth are not generally available, so many mechanics fabricate their own. A design that might have eliminated this problem incorporates a bolt with a large diameter thread for the inner nut and a smaller diameter thread for the two outboard nuts. The difference in diameters allows the inner nut to pass freely over the full length of the outboard thread without engaging it.

#### Bearing Damage (UH-1)

When replacing the grip seals in the UH-1 main rotor head, two rows of needle bearings become exposed as each grip is disengaged from the hub yoke. Individual needles occasionally pop out of their cage and become lost or damaged. If this happens, the rotor head must be sent to depot for bearing replacement. This problem might have been avoided if the cage were designed with tabs that would capture the reduced diameter ends of the needles.

#### Tight-Fitting Pins (UH-1, CH-47, CH-54)

Two tight-fitting dowel pins precisely locate the pitch change horn on the UH-1 rotor hub grip (Figure 16). In order to replace the grip seals, the pitch change horn must be removed. The dowels are difficult to disengage, particularly if installed with wet zinc chromate primer. The task might have been eased if provisions were made to insert a jackscrew in the pitch change horn between the two dowels.

To replace horizontal hinge pin seals in the CH-47 rotor head, the T-T strap must be disconnected by removing the strap retaining pins. In spite of the application of an anti-seizing compound at installation, these pins are difficult to remove. Removal of the pins might have been facilitated if the pins incorporated provisions for attachment of a standard slide-hammer type puller.

A tight-fitting taper pin must be removed to replace horizontal hinge pin seals in the CH-54 main rotor head. The pin is frozen prior to installation and is difficult to remove, requiring the use of a very large, heavy and cumbersome special tool. The force required to remove the pin might have been reduced by specifying a steeper taper and by selecting a grade of steel which exhibits better anti-galling qualities.

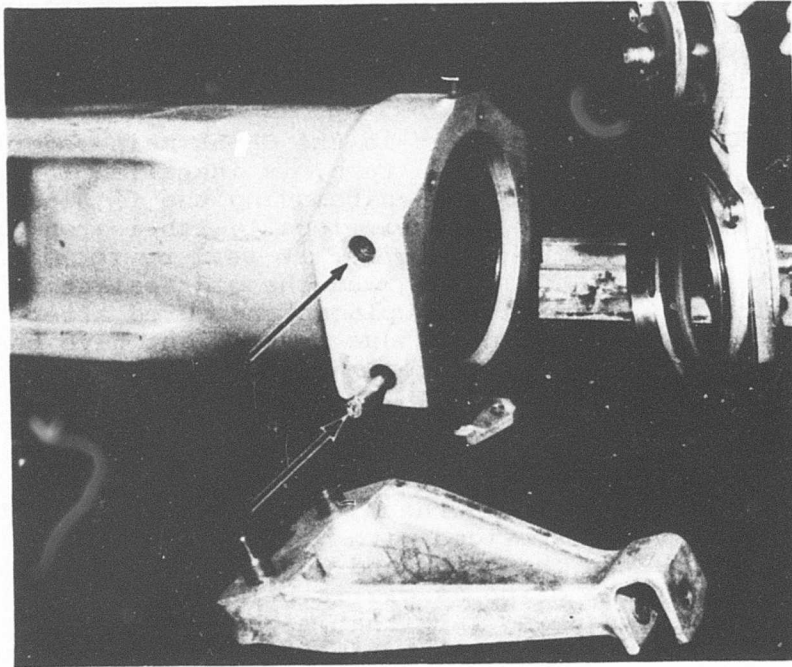

Figure 16. Pitch horn removed from grip, UH-1 main rotor hub assembly.

#### Disassembly Requirement (UH-1)

When replacing grip seals in the UH-1 main rotor hub, it is necessary to remove the pitch horn in order to rotate the grip 90 degrees to disengage an interlocking key and slot arrangement machined into the grip and hub yoke. It is possible that the key and slot mechanism might have been designed to permit disengagement within the amount of grip rotation available with the pitch horn installed.

#### Seal Installation Difficulty (UH-1, AH-1)

Installation of the large-diameter lip seal in the UH-1 and AH-1 swashplates requires the use of feeler stock to help work the lip of the seal onto the mating metal surface during assembly of the rotating and nonrotating rings. To some degree, this is a problem with all lip seals, the inside diameters of which must be smaller than the cylindrical surface they contact when installed. Installation is facilitated if there is an

adequate tapered lead or pilot on the end of the shaft over which the seal must be slipped.

#### Sealant Application Problem (OH-58)

The inboard end of the T-T strap in the OH-58 main rotor hub is pinned to a fitting which, in turn, is installed in the hub yoke and sealed (Figure 15). When removing the fitting for replacement of grip seals, a dowel, locally fabricated of aluminum or wood, must be used to break the seal by rocking the fitting back and forth. Cleaning out the old sealant is also required. The sealant must be replaced and cured after the fitting has been reinstalled. These tasks might have been avoided if the design incorporated an O-ring to seal the fitting.

#### Servicing Procedure (OH-58, UH-1)

After replacing grip seals in the OH-58 and UH-1 main rotor hub, the grips must be serviced with oil. During servicing, air becomes trapped in the grips and must be worked out by rocking (pitching) the grips as oil is being added. This is a tiring and time-consuming task that might have been avoided if the design incorporated a standpipe to provide a conduit for unobstructed travel of air from the highest point of the grip cavity to the highest point of the reservoir cavity.

#### Safetying Problem (UH-1)

To replace grip seals in the UH-1 main rotor hub, it is necessary to drain oil from the grip. The hex head of the drain plug is adjacent to a raised shoulder on the grip, which interferes with the task of threading safety wire through the holes in the plug following installation. It appears that the plug might have been located to prevent this problem. However, the situation could be improved with the current design by using a plug with greater head thickness.

#### DESIGN STUDIES

Improvements in lip seal maintenance were pursued from two directions. First, a number of concepts were studied with the aim of making the removal and installation of seals easier. These included several seal designs incorporating built-in removal provisions, a split lip seal and a slip-over seal design. Improvements in lip seal reliability were also studied. The application of ferrofluidic seals was investigated, together with a viscous fluid seal concept.

### Lip Seals With Built-in Removal Provisions

Typically, lip seals fill an annular space between a rotating shaft and a stationary housing with the seal secured to the housing. Static sealing with the housing is usually provided by a press fit, together with brushable sealer applied upon installation. In some installations, a lighter fit is used in conjunction with a thin bead of rubber applied to the outside diameter of the seal's outer shell during the molding process. In either case, the seal is pressed or tapped into the housing bore and is later removed using a puller. With some installations, removal is made more difficult by a requirement to disassemble sufficiently to expose the interior side of the seal so that it may be pressed from its housing using an arbor press. Several design concepts that show promise for easing the seal removal task were explored.

### Lip Seal With Expandable Rubber Retaining Ring

Figure 17 illustrates a design concept that uses a rubber ring, having the cross-section of a channel, to perform the dual functions of retaining and statically sealing a lip seal. The seal is conventional, except that it incorporates a circumferential depression in the outside diameter of its metal outer shell. This depression, and another in the gearbox housing counterbore, accept the rubber locking/sealing ring as it swells by insertion of a metal expander ring. The fit between the seal's outer shell and the gearbox housing bore is loose, so that the seal may be withdrawn by a mechanic using fingers alone, after removal of the expander and the locking/sealing rings.

Benefits. Most important among the advantages of this seal design is its lack of dependence on tools for installation and removal. Also, it eliminates the need for brushable sealant and the associated clean-up task. Seals of this type may be replaced in confined areas using feel alone. Replacement time should be reduced substantially. Weight should remain essentially unchanged.

Penalties. All of the anticipated penalties are relatively minor. There will likely be a slight increase in cost due to introduction of additional parts and additional machining of the gearbox housing bore. Some effort will be required to optimize the cross-section of the sealing/locking ring to ensure retention of the expander ring.

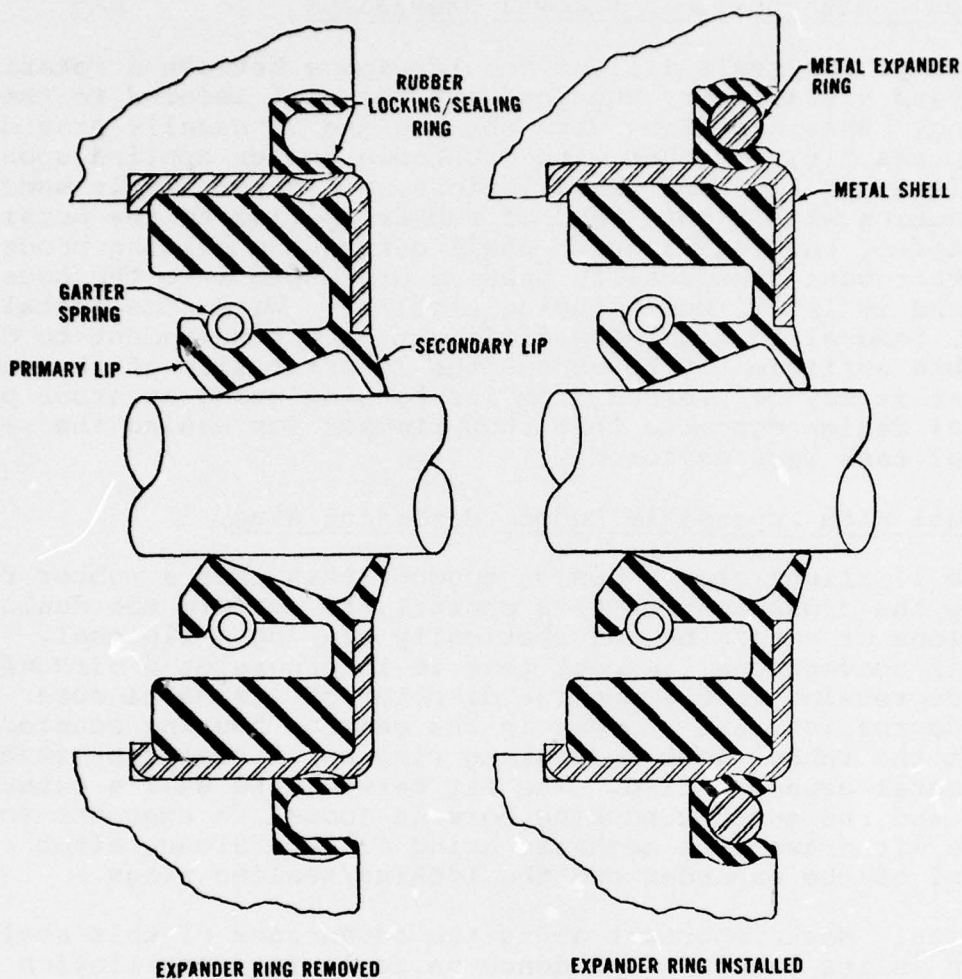

Figure 17. Lip seal with expandable rubber retaining ring.

#### Lip Seal With O-Ring Retainer

Figure 18 illustrates a concept that relies on a simple O-ring to perform the tasks of retaining and statically sealing a lip seal. A circular pattern of studs protrudes from the gearbox housing around the lip seal. A metal ring with a beveled inner edge is placed over the studs and captures an O-ring between itself and the housing. As the nuts on the studs are tightened, the O-ring is squeezed into a circumferential groove in the outer diameter of the lip seal's outer metal shell. Removal is accomplished in two steps. First, the stud nuts are loosened,

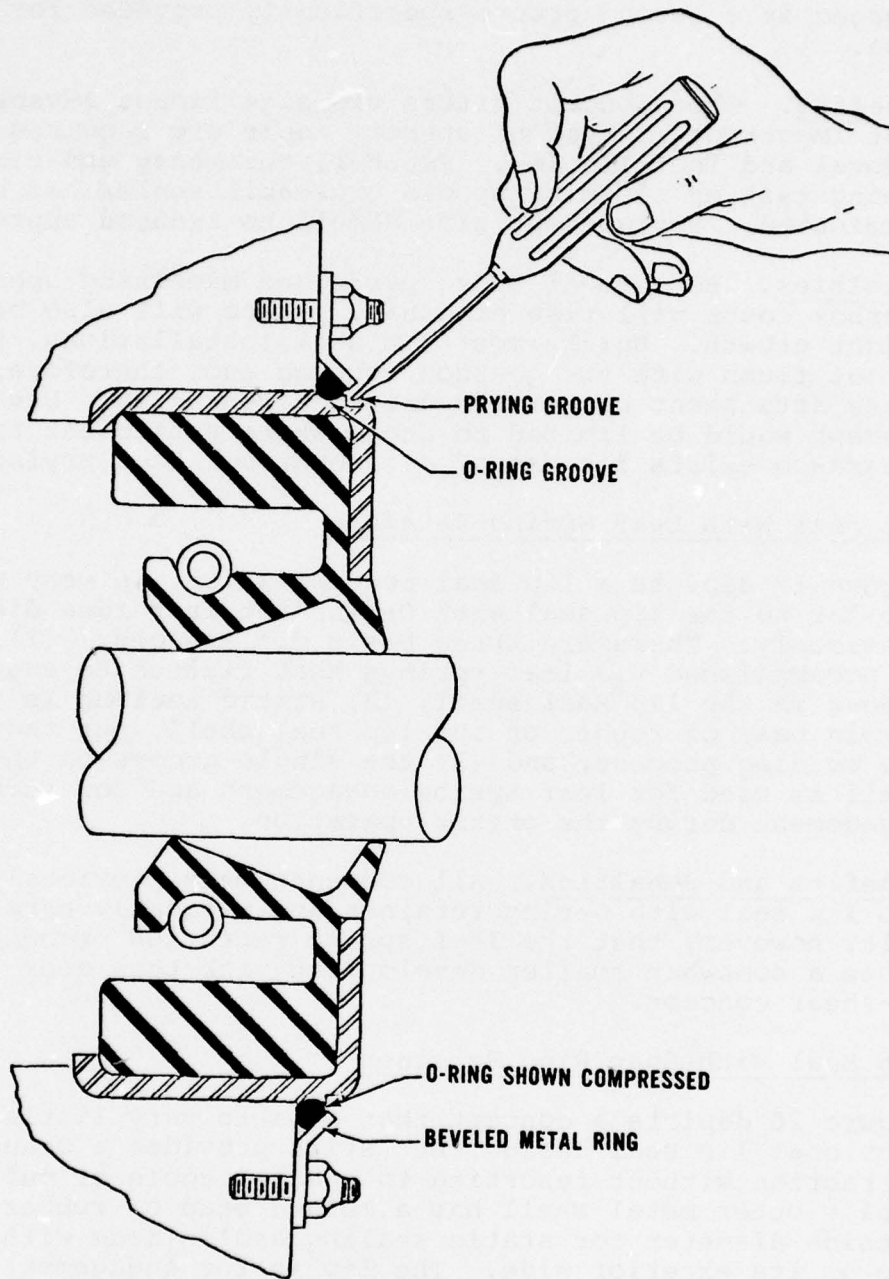

Figure 18. Lip seal with O-ring retainer.

allowing the elastic O-ring to withdraw from contact with the lip seal. The lip seal is then pried out using a screwdriver engaged in a second groove specifically provided for that purpose.

Benefits. This concept offers two significant advantages. Most important is that no special tools are required for removal and installation. Further, the messy and time-consuming task of cleaning up old brushable sealer has been eliminated. Replacement time should be reduced appreciably.

Penalties. Because of added parts and machining operations, gearbox costs will rise somewhat. There will also be a small weight growth. Unlike most lip seal installations, this one is not flush with the gearbox housing and, therefore, complicates attachment of gearbox-driven accessories. Use of this concept would be limited to areas where sufficient radial clearance exists for use of a screwdriver as a prying tool.

#### Lip Seal With Leaf Spring Retainer

Figure 19 depicts a lip seal concept which, in many ways, is similar to the lip seal with O-ring retainer idea discussed previously. There are three basic differences: (1) retention is accomplished via leaf springs that flatten to engage a groove in the lip seal shell; (2) static sealing is provided by a thin bead of rubber on the lip seal shell, put there during the molding process; and (3) the single groove on the lip seal shell is used for leaf spring engagement and for screwdriver engagement during the prying operation.

Benefits and Penalties. All comments made previously regarding the lip seal with O-ring retainer apply equally here. It is felt, however, that the leaf spring retention mechanism presents a somewhat smaller development risk than does the O-ring-in-shear concept.

#### Lip Seal With Snap Ring Retainer

Figure 20 depicts a concept that departs very little from conventional lip seal design, but still provides a means for extraction without resorting to special tools or pullers. The seal's outer metal shell has a molded bead of rubber on its outside diameter for static sealing and is made with a curled lip on its exterior side. The lip is for engagement of a screwdriver used as a prying tool during seal removal. A metal snap ring provides positive mechanical retention of the lip seal within the gearbox housing bore.

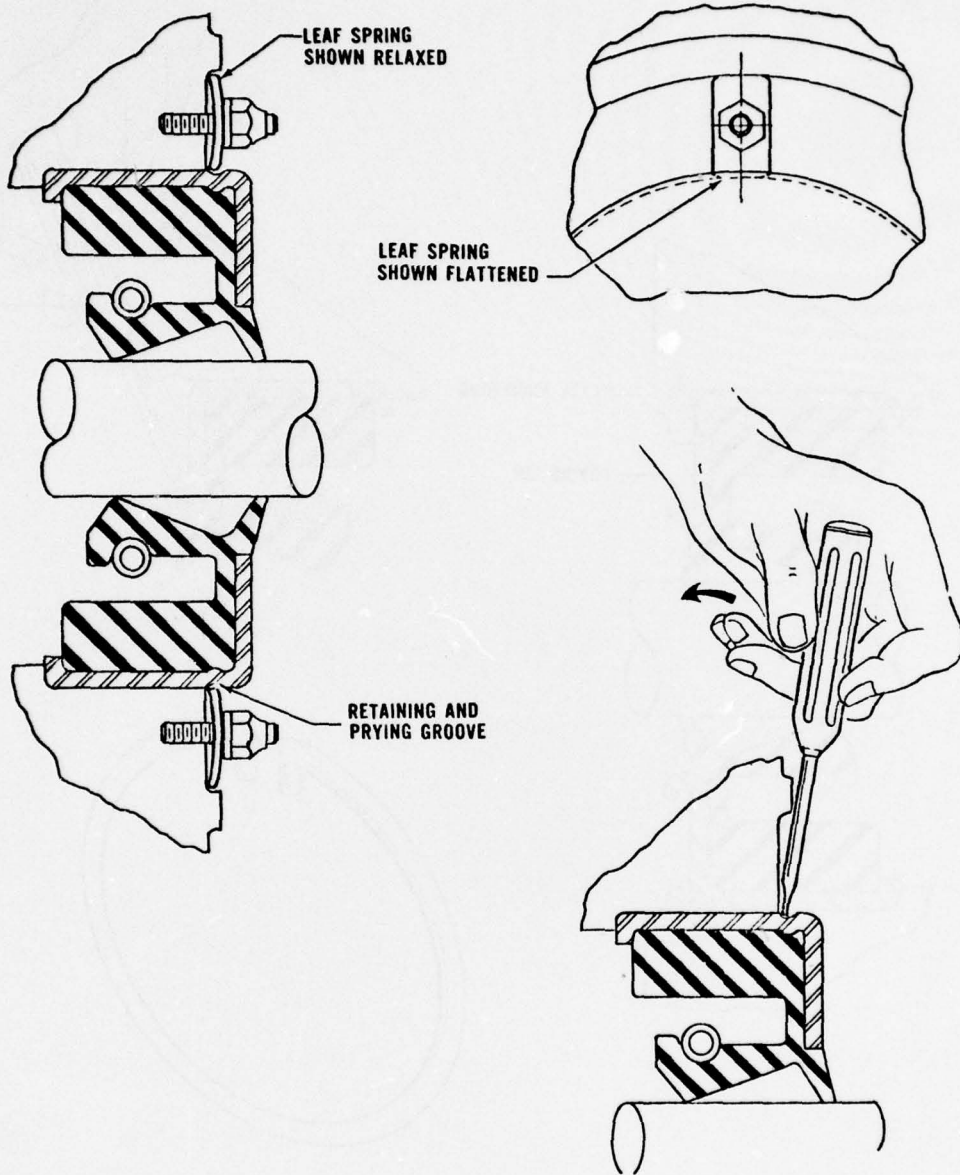

Figure 19. Lip seal with leaf spring retainers.

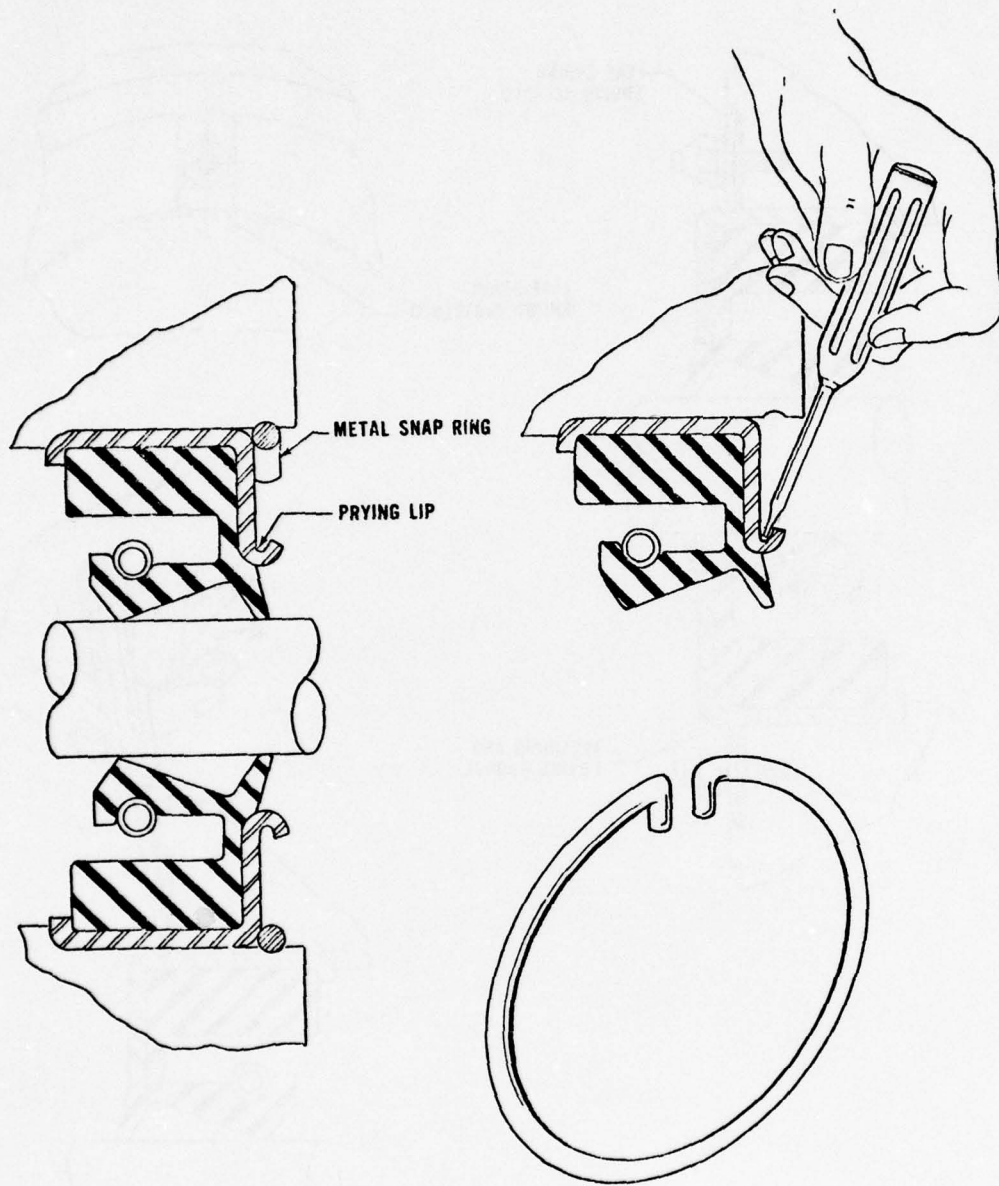

Figure 20. Lip seal with snap ring retainer.

Benefits. This concept's chief advantage lies in its ability to be removed without the use of special tools or pullers. Also, no brushable sealer is required. When installed, the seal is flush with the gearbox housing, thereby eliminating any possible interference problems when used at accessory mount locations.

Penalties. A very small cost increase is anticipated, as is a slight increase in weight. The screwdriver would engage the seal near its inside diameter, rather than at its outside diameter, which has the tight fit to overcome. The snap ring is essentially a back-up retention that does not restrain the seal from rotating in the gearbox housing bore. The concept relies upon the molded rubber bead on the seal's outside diameter for antirotational restraint.

### Split Lip Seal

Some lip seals are installed on shafts having a hub or flanged part that must be removed to gain access to the seal. One approach to eliminating these added tasks is to split the seal so that it can be installed around the shaft behind the obstructing hardware.

The seal is very similar to conventional molded rubber lip seals, except that it has a single split that allows it to be opened up sufficiently to install it onto the shaft. Figure 21 shows the method of installation. The split in the seal is in the form of a "V" notch. The seal is made slightly oversize in diameter so that adequate pressure is applied to keep the split tightly closed upon installation and during use. (The split would be oriented at the top in a horizontal shaft installation to minimize static leakage.) A split spring (not shown) is installed in the seal groove after the seal is assembled onto the shaft and prior to its insertion into the housing bore. (The spring might not have to be split if it could be ovalized enough to fit over the flanged parts.) A separate metal retainer, also split or made in two sections, would secure to the housing to hold the seal in its installed position. The seal could be designed with spiral flutes like the recently developed hydrodynamic seal to improve its reliability and performance.

Benefits. The major advantage of the split seal design is the maintenance time saved by avoiding the need to remove obstructing hardware for access to the seal. Cost and weight should not differ significantly from that of conventional molded rubber lip seals.

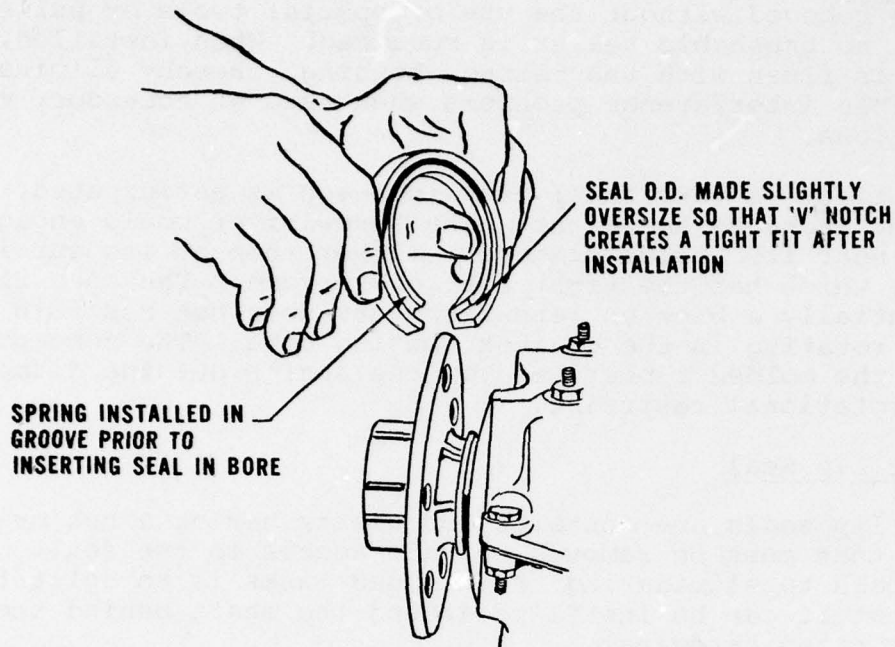

Figure 21. Split lip seal.

Penalties. The split seal would be limited to relatively low speed applications. It will not sustain pressures as high as those sustained by a single-piece seal and will tend to be less reliable. Vertical shaft installations may have a poor static sealing capability. The ideal design of the split may confine the application to a single direction of rotation. Depending upon the space between the seal bore and the obstructing flange, it may be difficult to install the spring in the seal groove. Flutes, if incorporated, may tend to draw dirt or moisture from the outside, unless provided with an additional dust shield. The design does not make removal of the seal itself any easier than current designs.

#### Slip-Over Lip Seal

Another approach to avoiding the need to remove hubs, flanges, etc., to gain access to the lip seal in some current types of installations is to make the seal flexible enough to slip over these larger diameter parts that obstruct its installation. Seals of this design are made by molding several layers and types of flexible rubber-like material into a unitized assembly. Having no metal shells like the more conventional lip seals, these units can be ovalized sufficiently (particularly when

the bore size is large) to permit installing them over a flange having a diameter larger than the seal inside diameter (Figure 22). The spring remains in the seal during installation or,

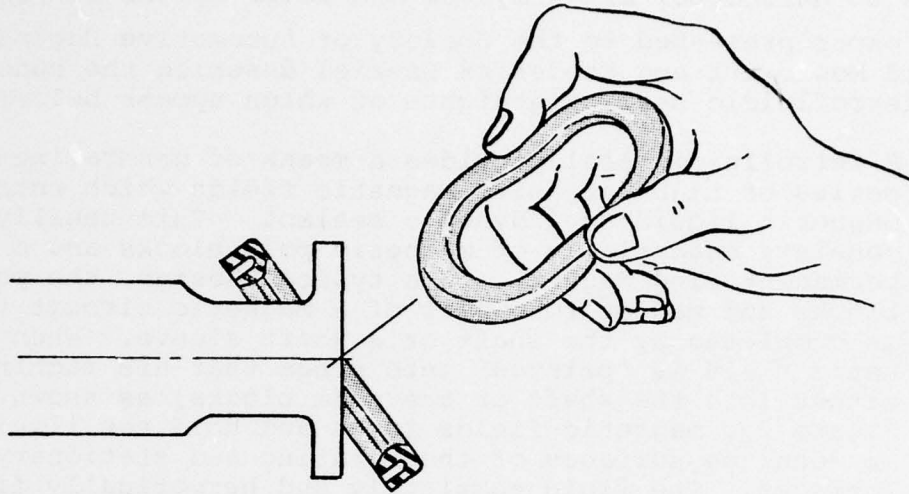

Figure 22. Slip-over lip seal.

if it has a tendency to pop out when the seal is deformed, it could be slipped onto the shaft first and fitted into the groove prior to inserting the seal into the bore. A split, or two-piece, seal retainer would be required. A split metal shell could also be assembled to the seal prior to its installation in the bore, if found desirable.

Benefits. The major advantage of this design, like the split seal concept discussed earlier, is the maintenance time saved by avoiding the need to remove hardware obstructing access to the seal. Cost and weight are not expected to differ significantly from those of a conventional seal.

Penalties. Achievement of a good static seal between the outside diameter of the lip seal and the housing bore may be difficult, and seal performance may not be as good in some applications. If the seal is too flexible, a guide tool may be needed to assist with the installation. Care must be exercised when the seal is ovalized and slipped over the flange or shaft protrusion to avoid nicks and scratches in the sealing surface.

## Ferrofluidic Seal

The Ferrofluidics Corporation, Burlington, Massachusetts, provided consultation to Kaman on the application of ferrofluidic seals to helicopter drive system and rotor system components.

In a paper presented to the Society of Automotive Engineers,<sup>4</sup> Ronald Moskowitz and Frederick Ezekiel describe the concept of the ferrofluidic seal, highlights of which appear below:

A ferrofluidic seal provides a means of generating a series of high intensity magnetic fields which entrap magnetic liquid as a dynamic sealant. This usually consists essentially of magnetic pole blocks and a permanent ring magnet. In a typical design, the pole blocks and magnet form part of a magnetic circuit that is completed by the shaft or a shaft sleeve. When a magnetic field is "painted" onto rings that are machined either into the shaft or the pole blocks, as shown in Figure 23, magnetic fields focus and hold the liquid between the surfaces of the rotating and stationary surfaces. The fluid completely and hermetically fills the gap between the surfaces as if it were a liquid O-ring or liquid lip seal. The pressure differential that the seal can withstand depends on the number of these O-rings, each ring typically withstanding a differential of 3 - 5 psi.

A magnetic liquid, or ferrofluid, is a colloidal suspension of magnetic particles in a carrier liquid that uniquely lends itself to the fabrication of non-wearing, zero-leakage, zero-stiction (sticking friction) rotary seals. Unlike a magnetic slurry, a ferrofluid is ultra-stable and the solid magnetic particles will not settle out of the base liquid. Mechanically and chemically, the magnetic fluid shares the characteristics of the carrier liquid in which the particles are colloiddally suspended. Typical carrier liquids are hydrocarbons, water, fluoro-carbons, esters, diesters, organometallics and polyphenyl-ethers. A ferrofluid may also contain other additives for the tailoring of special liquid properties, such as molydisulfide for improved lubrication.

4. Moskowitz, R. and Ezekiel, D., NON-WEARING FERROFLUIDIC SEALS, Paper 750851, presented at the SAE Off-Highway Vehicle Meeting, Milwaukee, Wisconsin, September 8-11, 1975.

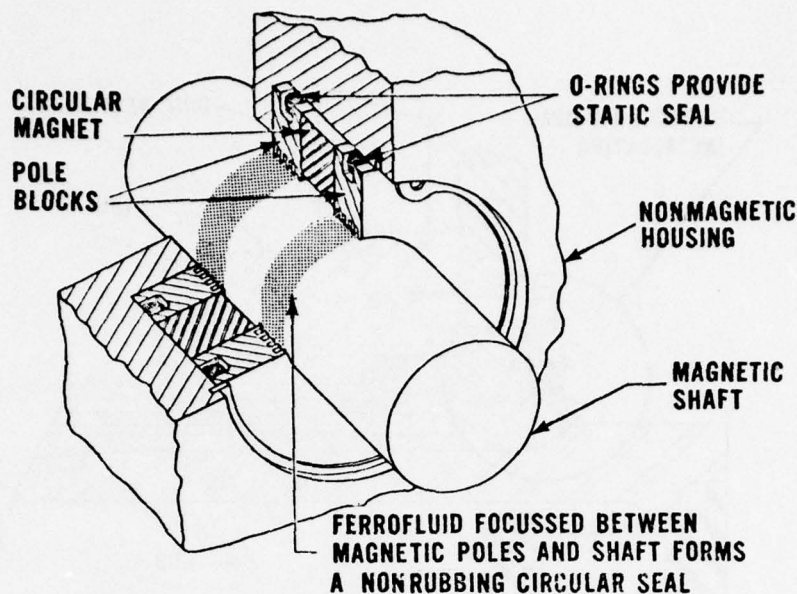

Figure 23. Typical ferrofluidic seal.

Fluid replenishment, due to evaporation, can be accomplished on a normal maintenance cycle or automatically via a ferrofluid reservoir.

#### Blade Grip Application

The application of a ferrofluidic seal to the UH-1H main rotor hub is shown conceptually in Figure 24. For this application (inboard grip seal), the ferrofluidic seal configuration consists of two circular pole blocks, sealed via conventional O-rings at their outside diameter contact with the grip housing, a cylindrical permanent magnet sandwiched between the two pole pieces, and the ferrofluid. The mechanical parts are all retained in the grip housing in much the same manner as the standard lip seal retention. The steel hub yoke spindle acts as part of the magnetic circuit and has a slight clearance with the inside diameter of the pole pieces. The ferrofluid is introduced into this gap and is held in place by the magnetic field. The ring of magnetized fluid acts as a frictionless seal lip or O-ring. The existing grip oil would probably be converted to a ferrofluid. It is also possible that a ferrofluid, separate from the lubricating oil and confined to the seal, could also be developed.

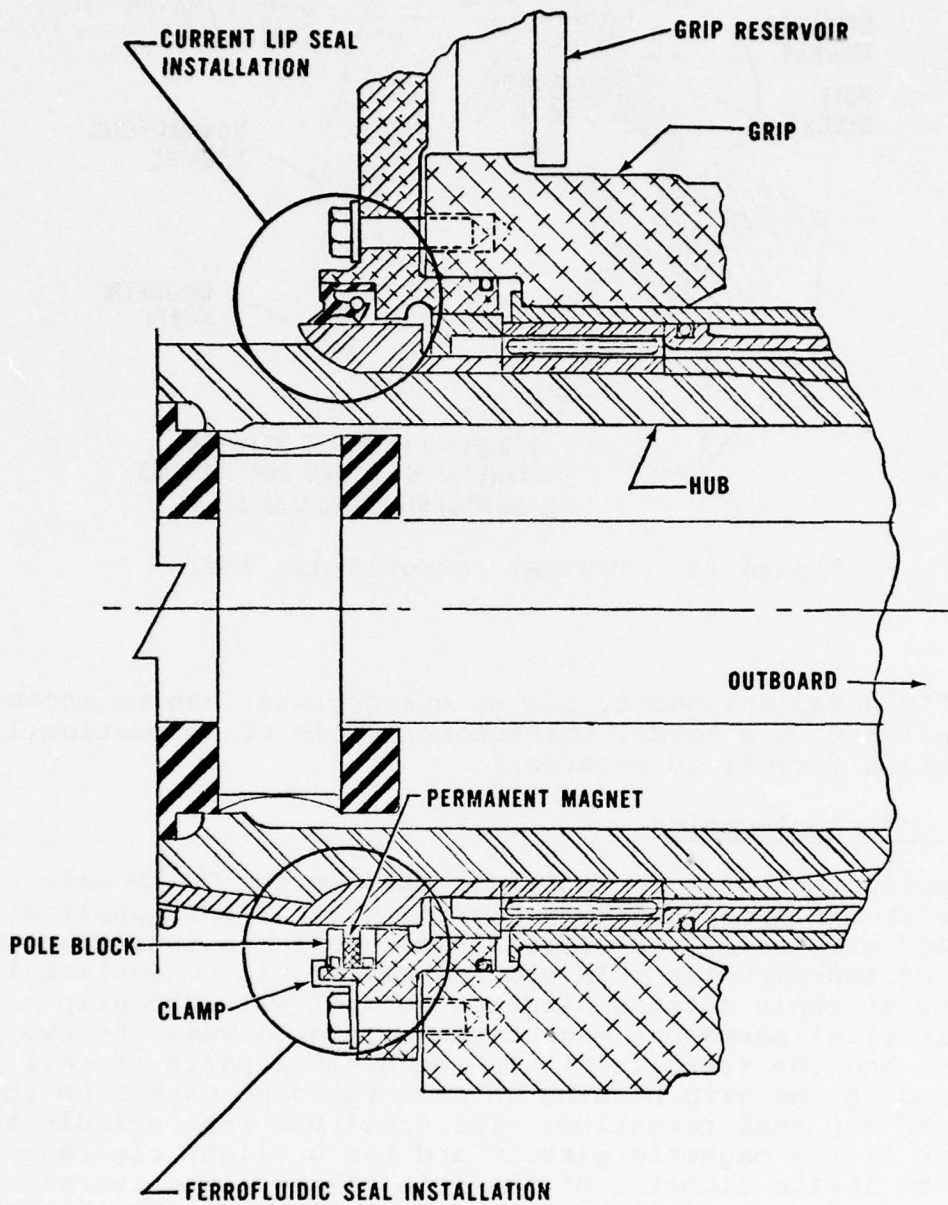

Figure 24. Conceptual application of a ferrofluidic seal to the inboard end of UH-1H main rotor grip.

Benefits. Much improved reliability and the prospect for lower life-cycle costs are the major attractions of the ferrofluidic seal. Since the seal parts are essentially unstressed and experience no wear, their reliability will be much higher than for any friction contact seal. The only apparent deterioration mechanism is that of slow evaporation of the ferrofluid, the rate of which will depend on the characteristics of the carrier fluid and the temperature. (The ferrofluid is readily replenished, however.)

Although initial cost will be greater, the life-cycle costs should be lower than those of a conventional lip seal, because the ferrofluidic seal will last the lifetime of the component and incorporates parts that could be reused indefinitely. (The cost of the ferrofluid will be a factor in the actual savings realized.) Weight differences should be negligible. Lubricating qualities (if the lubricating oil is used as the carrier fluid) should be as good. Moderate amounts of metal particles attracted to the seal from debris in the fluid will not affect performance.

Development risk associated with the application of ferrofluidic seals to helicopters is considered to be low. Selection and qualification of the ferrofluid is the major uncertainty. In applications where centrifugal force places the seal under larger pressures, such as would be true for the outboard seal of the rotor hub grip reservoir, the number of stages in the seal would have to be increased.

Penalties. The ferrofluidic seal will have a higher initial cost, and the ferrofluid in quantities presently produced is very expensive. If the ferrofluid is also used as the lubricating fluid, as in the case of the grip reservoir seal, the reservoir volume would have to be reduced to a bare minimum for the concept to be economically viable. Amounts of the ferrofluid will have to be stocked in supply; shelf life will be that of the carrier fluid.

#### Gearbox Input Shaft Application

A ferrofluidic seal, similar in configuration to that shown in Figure 23, could be adapted to the input shaft of a main transmission. If the ferrofluid used in the seal is not also used as the basic lubricating oil in the gearbox, provisions will be needed to avoid dilution of the ferrofluid through contact with the oil. This would probably require development of a ferrofluid that is non-miscible and chemically inert with the lube oil, and the use of slingers, drains and baffles as needed to minimize contact of the lube oil with the ferrofluid. An alternative involving greater risk would be to develop a ferrofluid version of the basic lube oil. Comparative laboratory

wear tests with several base oils indicate that the addition of magnetic particles to the oil does not degrade performance and, in some instances, may even be beneficial.

Benefits and Penalties. The ferrofluidic seal in this application has much the same advantages and disadvantages as described for the blade grip application earlier. At present prices, the use of ferrofluid as the basic lubricating oil in the gearbox might be prohibitively expensive. The addition of a new lubricant to the supply system would also be a substantial deterrent, unless it had very widespread application.

### Viscous Fluid Seal

The high man-hour cost of replacing lip seals in major dynamic components of helicopters is as much a result of poor reliability as it is the time required to effect the repair. A viscous fluid seal represents one concept for improving seal durability. Referring to Figure 25, this seal consists of a rotating container assembly with a flanged sealing member that is entrapped by, and rotates within, a nonrotating shell. The cavity in the rotating container contains a semiviscous fluid, which is the primary sealing element. The sealing flange is made thin and smooth to provide minimum friction between it and the sealing fluid. Dust and oil shields are provided to restrict contaminants from entering the fluid chamber. If replenishment of the fluid is necessary, it can be introduced into the cavity under or through the dust shield.

The working fluid must have a viscosity and viscosity index suitable to keeping the fluid together and confined, whether the seal is in operation or at rest. It should have a density greater than oil or whatever other liquid is being sealed. It should not be soluble in the fluid being sealed and should be noncorrosive and stable.

Benefits. This concept represents a design that should have a very long service life since it has no rubbing parts and, therefore, should experience little or no wear. In addition, if the seal should begin to leak, a simple procedure of adding more working fluid to the seal should restore the unit to satisfactory operation. Other apparent advantages are its high speed potential, its liberal axial positioning tolerances, and its ability to accommodate eccentricity and shaft whip. It should also be less vulnerable to handling damage.

Penalties. The viscous fluid type of seal has been developed successfully in an application where a vertical stationary shaft was sealed against a rotating outer housing. The application of the concept to (horizontal) helicopter gearbox shafts presents a different set of conditions and would require

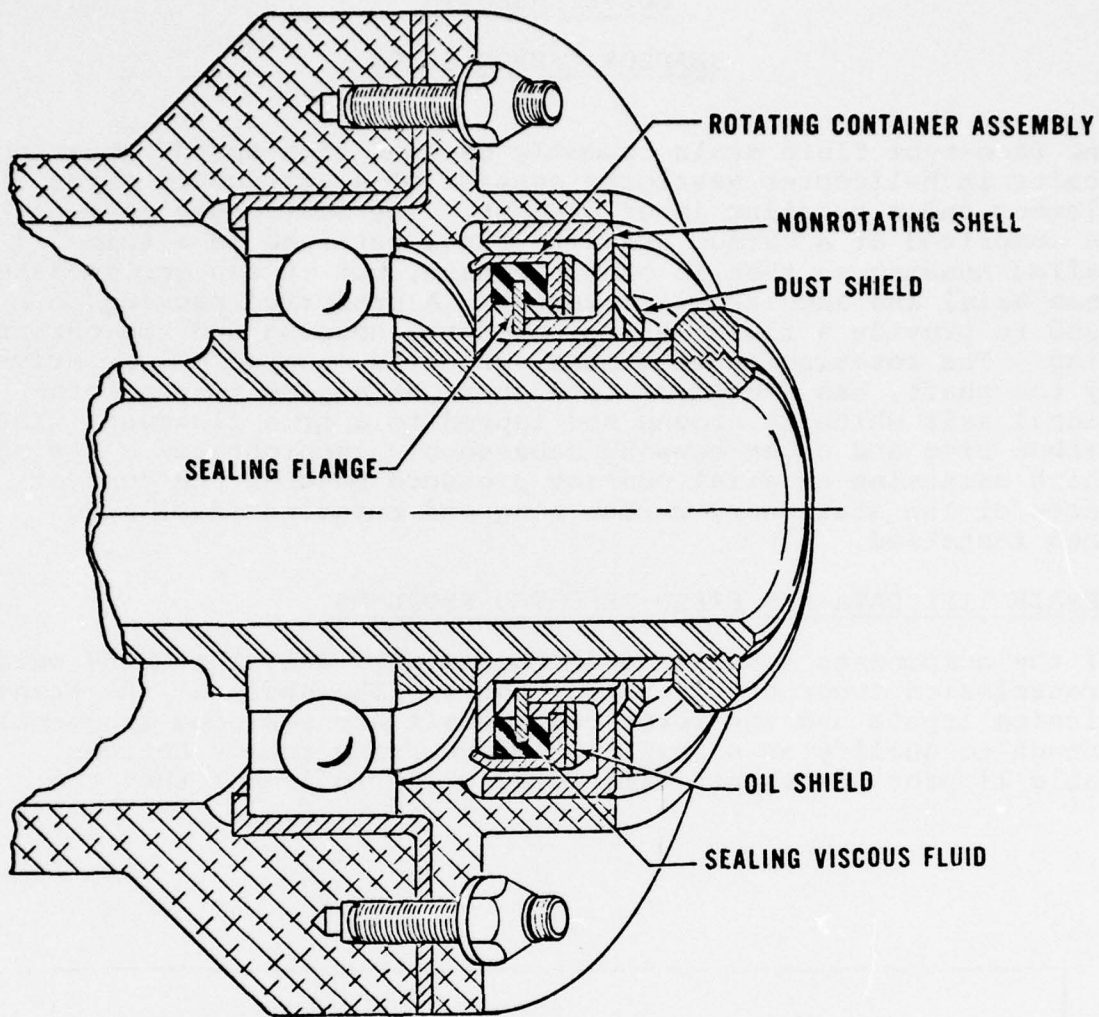

Figure 25. Viscous fluid seal.

considerable development. Finding a suitable sealing fluid, possessing all of the required properties, may be difficult. It is expected that a viscous seal, if successfully developed, would be confined to relatively low-pressure differentials and would be more costly than conventional lip seals (although possibly less expensive than face or circumferential seals).

SURVEY RESULTS

GEARBOX CARBON SEALS

The face-type fluid seals commonly used on high-speed, rotating shafts in helicopter gearboxes consist of a stationary outer element and a rotating inner element. The stationary element is comprised of a carbon graphite ring, retained in a thin-walled housing so that it cannot rotate, but it can accommodate some axial and angular displacement. A preformed packing is used to provide a fluid seal between the housing and the carbon ring. The rotating inner member, which is mounted on and driven by the shaft, has a contact face at right angles to the rotational axis which is ground and lapped to a true flatness. The carbon ring and outer housing subassembly incorporates a spring which maintains an axial contact pressure between the contact faces of the stationary carbon ring and rotating steel ring when installed.

REPAIR TIME DATA AND FIELD-REPORTED PROBLEMS

Of the components considered in this study, only the CH-54 main transmission incorporates carbon seals. The seals at the transmission inputs and the rotor brake shaft are replaced frequently enough to qualify as significantly occurring repair actions. Table 11 provides repair time data, which indicates that the

TABLE 11. REPAIR TIME DATA, GEARBOX CARBON SEALS							
Model	Component/Part		Elements of Replacement Task				
			Total Task Time	Dis-assy. and Assy.	Adjst, Align, Etc.	Drain Lube Ser-vice	In-spect and Test
CH-54	Main Transmission (Input Seal)	Hrs.	29.0	27.0	0.6		1.4
		Pct.		93.1	2.1		4.8
CH-54	Main Transmission (Rotor Brake Shaft Seal)	Hrs.	9.1	8.0		0.1	1.0
		Pct.		87.9		1.1	11.0
Weighted Average		Hrs.	23.4	21.7	0.4	0.0	1.3
		Pct.		92.7	1.7	0.0	5.6

input seal replacement is the more lengthy procedure. This is so because the respective engine must be disconnected and shifted forward to provide access to the seal. While offering longer life than the more commonplace lip-type seals, carbon seals are particularly susceptible to damage during shipment and handling. Poor access and the difficulty of removing and installing the large spanner nut at the rotor brake output shaft were also reported as problems by mechanics in the field.

#### Access Problems (CH-54)

Much of the time involved in replacing input drive seals on the CH-54 transmission is expended on disconnecting and moving the engine forward to gain access to the input area. To replace rotor brake shaft seals on the transmission, the rotor brake housing must be removed. Removal is necessary because a bleeder port boss cast into the housing (Figure 26) interferes

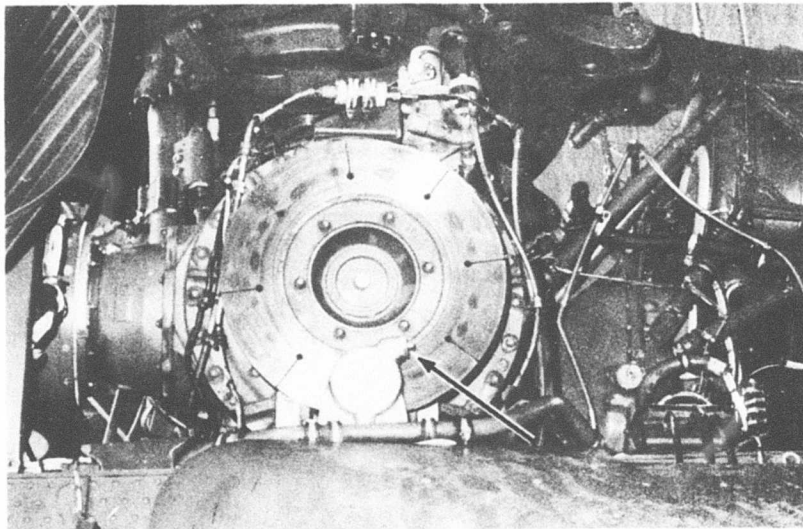

Figure 26. Rotor brake installation, CH-54 transmission.

with the removal of the brake disc adapter from the output shaft. Having removed the brake housing, a puck-to-disc clearance check must be made and shim adjustments are often required. These tasks might have been avoided if the bleeder port boss had been located differently during initial design.

### Seal Preparation (CH-54)

Prior to the installation of a replacement seal at the input drives or rotor brake output shaft of the CH-54 transmission, the seal must be soaked in oil for 24 hours. A different method of packaging, using an oil-filled, leak-proof container, might provide a ready-to-install seal, as well as offering greater protection against shipping damage.

### Seal Handling Damage (CH-54)

The carbon seals used at the input drives and rotor brake output shaft of the CH-54 main transmission are extremely vulnerable to handling damage. Such damage often goes undetected and occasionally two or three seals are successively installed before leakage is eliminated. It is recognized that carbon seals offer the advantage of a relatively long life; however, because of the unique installation problems they present, using less vulnerable and much less expensive lip-type seals may be the preferable alternative.

### Spanner Nut Removal and Installation (CH-54)

To replace the rotor brake shaft seal on the CH-54 transmission, a large-diameter, high torque spanner nut (Figure 27) must be removed and reinstalled. This is a three-man job performed on the engine deck high above ground level. One man

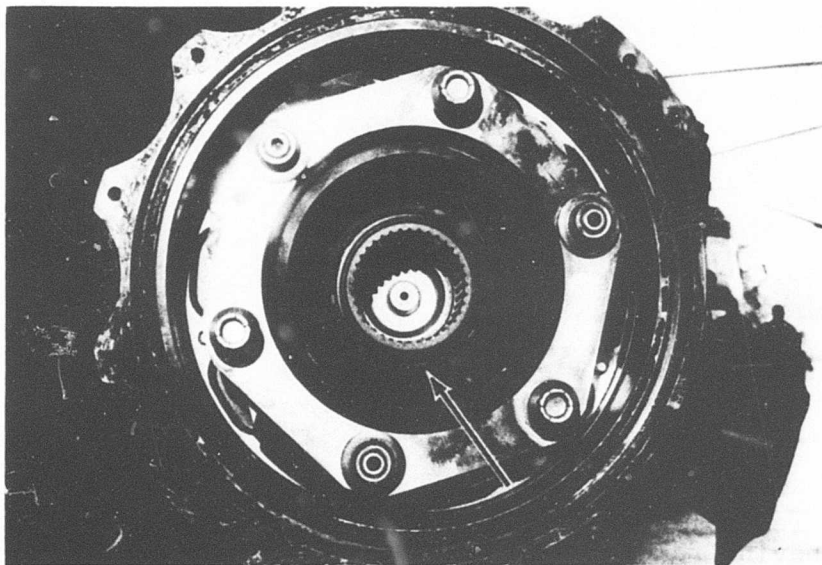

Figure 27. Input spanner nut, CH-54 transmission.

holds a shaft restraining tool, the second holds the socket wrench engaged with the nut, and the third applies torque via a long breaker bar. The nut has eight slots on its outside diameter, four of which are engaged by tabs on the special socket (Figure 28). The width of the slots is such that the nut appears to have eight tabs rather than eight slots. After being used a few times, the tabs on the socket begin to round off and great difficulty is experienced trying to maintain engagement with the nut. The fact that the slots are much larger than the tabs on the socket and only four slots are engaged at one time, contributes to the problem.

The problem with the socket might have been avoided if the outside diameter of the nut had been designed with spline teeth instead of slots. The special socket could then have a mating female spline for more positive engagement and better reliability than is provided by the present tabs. The need for three men could also be eliminated by designing the socket to be used with one of the compact torque multiplying devices available. This type of torque wrench is installed and operated easily by one mechanic.

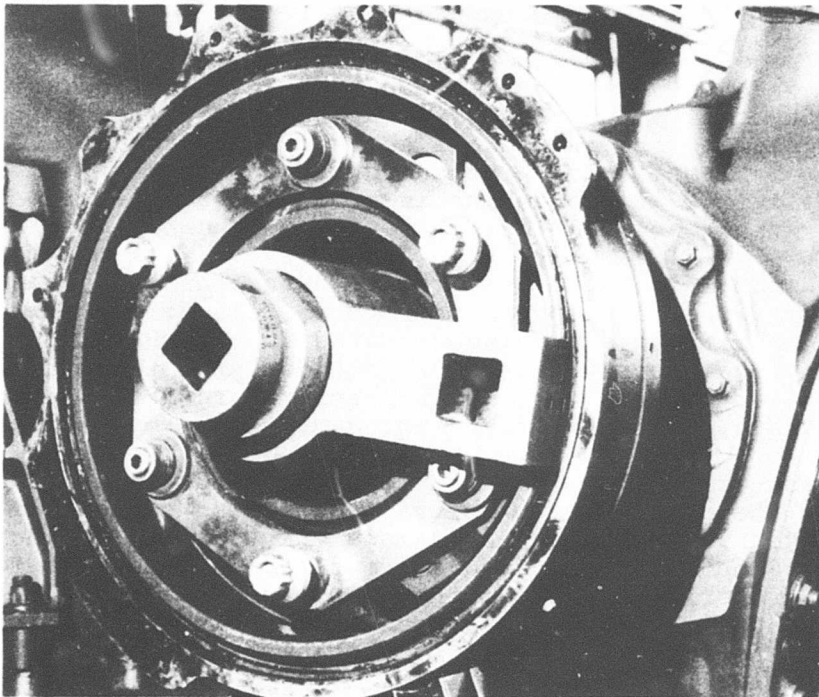

Figure 28. Special socket in-place, input spanner nut, CH-54 transmission.

## SURVEY RESULTS AND DESIGN STUDY

### HYDRAULIC ACTUATOR O-RING SEALS

Hydraulic actuator O-ring seals are usually installed in cavities or grooves designed to provide the proper seal squeeze or compression. The seals may be installed between members that are locked together, in which case, they function as static seals. If one of the parts contacting the seal is mobile, the seal is dynamic, i.e., required to slide on its surface. When high pressure sealing is required, the O-ring is usually installed between a pair of Teflon backup rings to prevent extrusion of the seal into the clearance gap between the metal parts.

Provisions for inserting the O-rings and backup rings vary greatly with the actuator design. Assembly conditions have a considerable influence on the difficulty of repair and the ability to avoid maintenance-induced damage.

### REPAIR TIME DATA AND FIELD-REPORTED PROBLEMS

Leakage problems, either internal or external, always result in removal of the discrepant actuator for shop repair. The receiving shops will either bench test all incoming actuators to verify complaints, or they will arbitrarily recondition the entire assembly, replacing all seals in the process. Post-repair bench testing is a standard procedure in any case. These practices are effective in producing quality repairs, but account for almost half of the repair man-hours.

Table 12 summarizes the repair time data generated via field interview. The data covers only three Bell helicopter models, because no actuators are incorporated in the OH-6 flight controls and the shops visited were not equipped to repair CH-47 and CH-54 actuators. All of the repairs are accomplished off the aircraft, requiring from approximately 5 to 9 man-hours.

One aspect of the problem with repair of hydraulic actuators concerns the difficulty of extracting O-ring seals from internal grooves and the frequent damage they sustain during installation. Sometimes, repeated attempts are necessary before a seal is properly installed; the improper installation is usually not found until the unit has been completely reassembled and tested. The following specific problems were cited by people in the field:

TABLE 12. REPAIR TIME DATA, HYDRAULIC ACTUATOR O-RING SEALS

Model	Component/Part		Elements of Replacement Task					Component Repl. Time *
			Total Task Time	Dis-assy. and Assy.	Adjst, Align, Etc.	Drain, Lube, Ser-vice	In-spect and Test	
OH-58	Servo Actuator (Piston Seals)	Hrs. Pct.	5.4 40.7	2.2 40.7			3.2 59.3	2.6
UH-1	Flt. Control Cyl./Valve (Piston Seals)	Hrs. Pct.	5.4 55.6	3.0 55.6		0.1 1.9	2.3 42.6	3.8
AH-1	Flt. Control Cyl./Valve (Piston Seals)	Hrs. Pct.	8.4 65.5	5.5 65.5		0.1 1.2	2.8 33.3	3.2
OH-58	Servo Actuator (Valve Body Seals)	Hrs. Pct.	4.4 40.9	1.8 40.9			2.6 59.1	2.6
UH-1	Flt. Control Cyl./Valve (Head/Pilot Valve Seals)	Hrs. Pct.	5.1 52.9	2.7 52.9		0.1 2.0	2.3 45.1	3.8
AH-1	Flt. Control Cyl./Valve (Spool & Head Seals)	Hrs. Pct.	9.1 71.4	6.5 71.4		0.1 1.1	2.5 27.5	3.2
Weighted Average		Hrs. Pct.	7.2 62.6	4.5 62.6		0.1 1.4	2.6 36.2	
* Off-aircraft tasks.								

Seal Friction (OH-58)

To withdraw the valve from the OH-58 hydraulic actuator for replacement of valve body seals, considerable force is required to overcome the friction of the O-rings. Incorporation of a threaded hole in the exposed end of the valve would have permitted the use of a standard, slide-hammer type puller.

Seal Extraction Difficulty (OH-58, UH-1, AH-1)

Valve body seals in the OH-58 hydraulic actuator, and head and pilot valve seals in the UH-1 and AH-1 hydraulic actuators, are difficult to extract from the circumferential grooves in the lower ends of the valve bores. The bore diameter is small (roughly 1/2 inch) and the seal protrudes very little above the groove. Mechanics resort to using hook-shaped picks (Figure 29) to extract the seals, and scratches on the highly

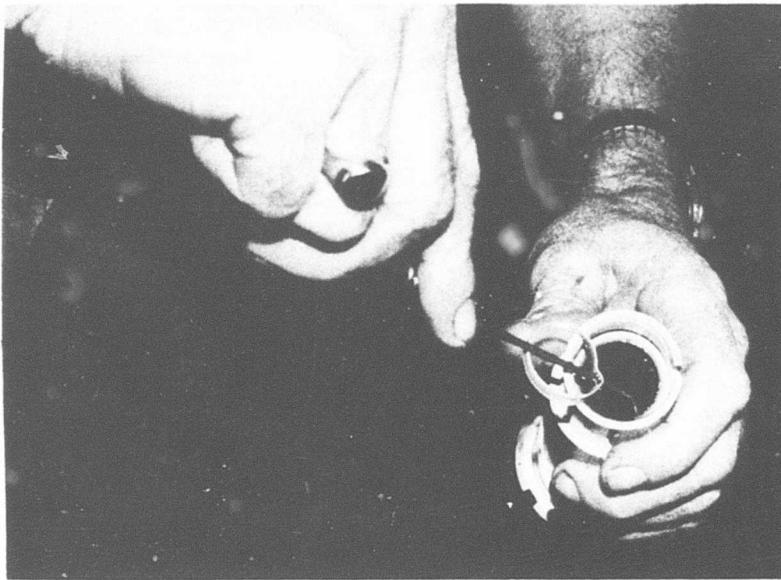

Figure 29. Use of pick to remove hydraulic actuator O-ring seals.

polished metal sealing surfaces often occur. This problem is among those addressed by the design concept studies concluding this section of the report.

#### Seal Damage (UH-1, AH-1)

When replacing piston seals in the UH-1 and AH-1 hydraulic actuators, seals in the cylinder cap are sometimes cut by sharp threads on the end of the piston rod as the cap is slipped onto the rod (Figure 30). The problem can be avoided by modifying the current assembly procedure to require temporary application of masking tape to the threads for installation of the cap.

#### Intricate Assembly Procedure (AH-1)

To replace piston seals in the AH-1 hydraulic actuator, an intricately machined metal bushing, called a packing retainer, must be removed and reinstalled mid-way down the bore of the cylinder. The retainer is locked in position via three keys which engage circumferential grooves in the cylinder wall and slots milled into the outside diameter of the retainer (Figure 30). In operation, the keys react shear loads. The slots in

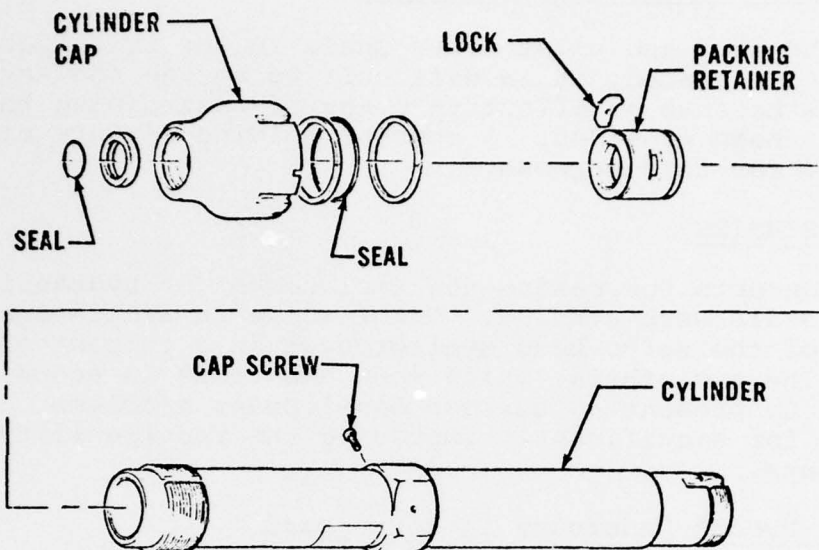

Figure 30. AH-1 hydraulic actuator, partial assembly.

the retainer are deep enough to accept the full depth of the keys so that they and the retainer will pass down the cylinder bore. Once in position down the bore, it becomes an exacting task to pull the keys part way out of the slots in the retainer and bring them into engagement with the groove in the cylinder bore. This is done by inserting cap screws through radial holes in the cylinder wall and threading them into holes in the keys. It is not unusual for mechanics to make several time-consuming attempts at this before making a successful installation.

An alternate design that might have avoided this problem modifies the slots in the retainer and places a flat spring under each of the keys to force them into engagement with the cylinder bore groove automatically. Disassembly would be accomplished by passing pins through radial holes in the cylinder wall, compressing the springs and pushing the keys back into the slots in the retainer.

#### Holding Tool Deficiency (UH-1)

A special device is provided to hold the UH-1 hydraulic actuator for replacement of piston seals. The tool is deficient in that it grips the cylinder in the area where the nameplate is attached and does not provide sufficient restraint when torque is applied to the spanner nuts.

### Torque Application Problem (UH-1)

After the head and pilot valve seals in the UH-1 hydraulic actuators are replaced, it is difficult to torque the servo head locknuts because no effective means of restraining the servo head has been provided. A special holding fixture might be designed for this purpose.

### DESIGN STUDIES

Three concepts for easing the replacement of hydraulic actuator O-ring seals were studied. One involves a simple change in the design of the servo head seal grooves in a current configuration. The two others, while more ambitious in scope, are considered to present no serious development problems, and show promise for significantly improving the repairability of these components.

#### "Murphy-Proof" Undercuts in Servo Head

The sketches in Figure 31 illustrate the interface between the servo head and actuator piston rod in the UH-1 hydraulic actuator. The present design is illustrated in the top view, showing that there are two O-rings installed in internal grooves, and that the housing also contains an undercut for fluid flow which closely approximates the O-ring grooves. Two difficulties have been noted in repair of this configuration. Removal of the seals requires the use of a small pick, which can damage the aluminum housing. On reinstallation, one of the seals may inadvertently be installed in the undercut. This could easily go undetected until functional test following assembly.

In the proposed configuration, also shown in Figure 31, the depth of the undercut has been reduced to prevent inadvertent O-ring installation. The piston rod will not fit in the housing if the O-rings are improperly installed.

Benefits. The suggested design scheme could be adopted with no affect on cost or weight, and without the necessity for a development program. The only caution which need be exercised is that the undercut not be reduced below a cross sectional area which is adequate for hydraulic flow. This may be reliably determined by analysis.

The primary gain is in ease of repair, eliminating the chance for erroneous seal installation which would not be discovered until functional test. The potential time saved includes the subsequent disassembly, reassembly and retest which would be needed to correct the error.

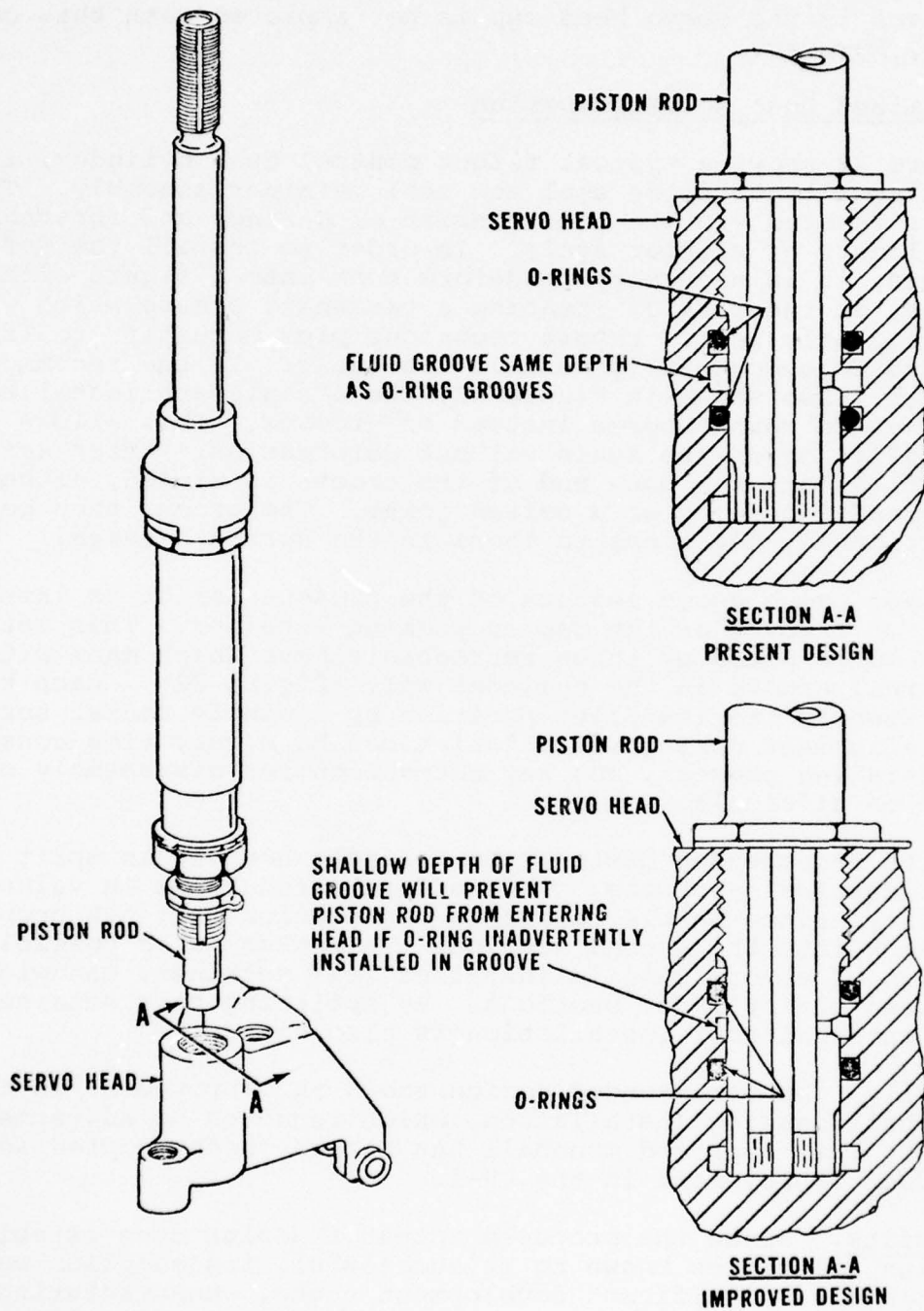

Figure 31. Murphy-proof undercuts in the servo head.

Penalties. The proposed design scheme presents no apparent penalties. The difficult task of removing the seals from the grooves in the servo head cap is not improved with this concept, however.

#### Optimized Dual Actuator Design

Figure 32 shows a typical flight control dual cylinder, illustrating a troublesome seal and seal retainer assembly. The seals denoted via the note consist of O-rings and internal Teflon liners or slipper seals. In order to install the Teflon liners, it is necessary to deform them into a figure eight shape, at the risk of creating a permanent crease which will subsequently leak. Expert technique plus makeshift tools are needed to successfully install the seals. In the recommended design, also shown in Figure 32, these seals are installed in open-ended counterbores instead of grooves. This allows installation of the seals without deformation. After seal installation, the open end of the groove is closed, either by a threaded bushing or a bolted joint. The groove then becomes functionally identical to those in the current design.

Another troublesome feature of the present design is installation or removal of the center packing retainer. This retainer is held in place by three retractable keys which mate with an internal groove in the cylinder wall (Figure 32). Each key is retained in its installed position by a single radial screw. Key alignment during installation can be a very time-consuming, painstaking process, and key retraction for disassembly can also be difficult.

In the recommended design, the cylinder housing is split into two identical sections. This offers a reduction in vulnerability, since battle damage to one section will not propagate a crack into the second section. This also makes possible the design of a more readily installed seal retainer, sandwiched between the cylinder sections. By splitting this retainer, the internal seal installation is also eased.

Finally, the recommended design shows an improvement in the monoball bearing installation, which requires no adjustment for drag. This improved monoball has already been adopted as a product improvement in the UH-1.

Benefits. Since the proposed actuator design uses established design principles known to be successful, its adoption would not involve significant development risks. Manufacturing costs should not differ substantially, since, although a greater number of parts are used, they are simpler and repetitive.

NOTE: TEFLON CHANNELS FOR INTERNAL SEALS OF CURRENT DESIGN CYLINDER MUST BE DISTORTED AS SHOWN BELOW TO PERMIT INSTALLATION. PERMANENT CREEPING AND SUBSEQUENT LEAKAGE CAN OCCUR.

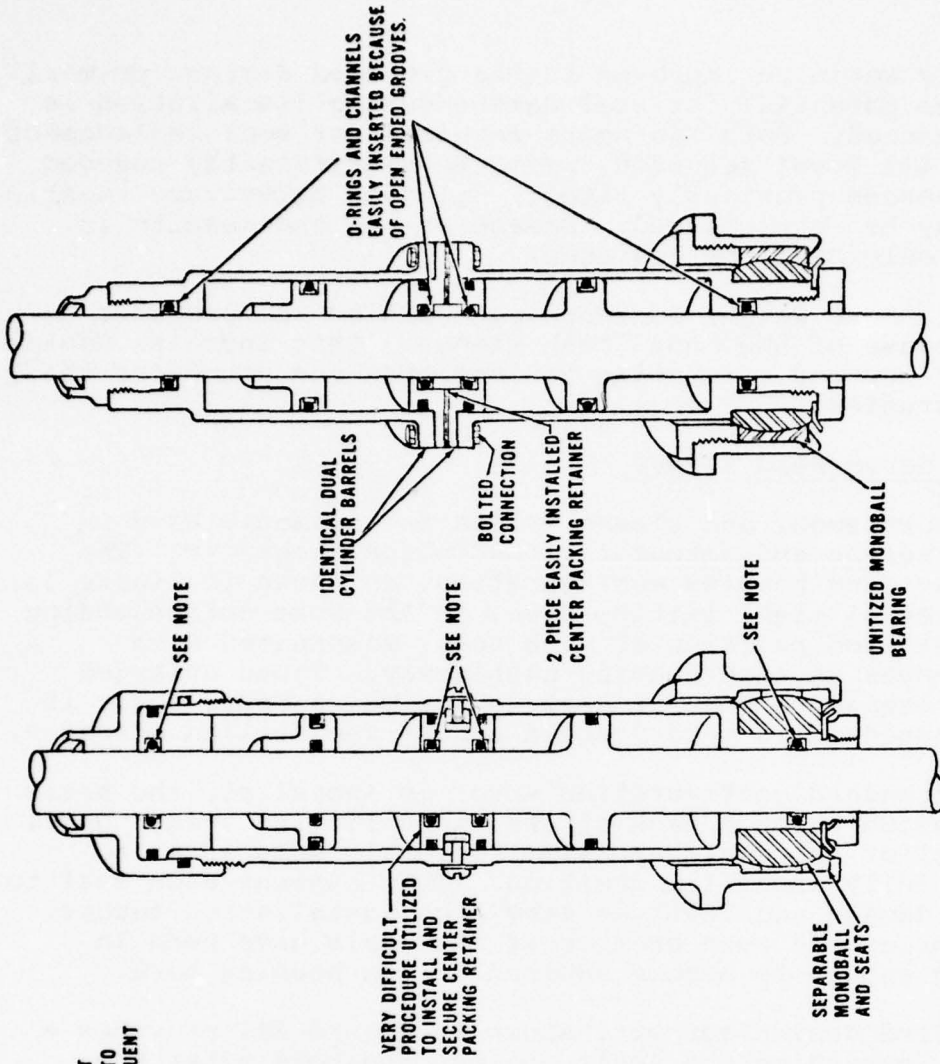
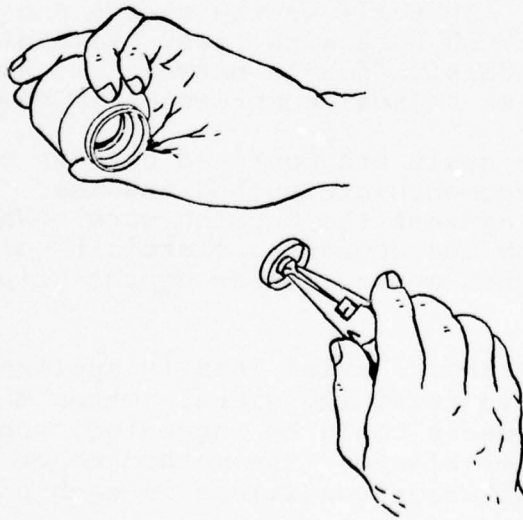

CURRENT DESIGN

OPTIMIZED DESIGN

Figure 32. Optimized dual actuator design.

Reliability would be improved in the proposed design, primarily because the potential for seal damage during installation is greatly reduced. Both man-hours required for seal replacement, and the skill level required, would be significantly reduced for the reasons previously cited. Cylinder halves are identical and may be interchanged. Damage at one end results in scrapping only half the cylinder.

Penalties. Some weight increase accompanies the proposed design because of the added bolt flange. This increase would be modest, however, amounting to less than one pound for the actuator studied.

#### Segmented Servo Head Sleeve

Multiple port spool and sleeve valves are commonly used in hydraulic servos and actuators, and in fuel controls. The usual sleeve and housing configuration, as shown in Figure 33, has a series of tight fitting areas in the bore corresponding to the installed position of each seal, alternated with enlarged bores at each housing passageway. These enlarged areas are needed to prevent seal damage which would occur if the compressed seals were dragged across the drilled passages.

When the standard configuration spool is installed, the seals must be forced through each of the tight fitting areas, until finally all of the seals are simultaneously compressed to reach the fully installed position. This exposes each seal to potential damage and involves very high installation forces. Removal forces are even greater if the seals have been in place long enough to become adhered to the housing bore.

The suggested design concept, shown in Figure 34, provides a method for expanding the seals against the bore after the sleeve is in place. This allows the sleeve and seals to be slipped into the smooth bore with ease. Removal is also facilitated, since the adhesive forces between the seals and bore would tend to release as seal compression is removed.

In this scheme, the seals are confined between moveable sleeve segments. As the segments are pushed together, the seals are forced to move out against the housing bore. When the axial load is removed from the segments, elasticity of the seals will push the segments apart, loosening the grip between the seals and bore.

In the illustration shown, axial load is applied to the sleeve segments by the valve retaining gland. Other methods for providing the axial squeeze could be suggested, such as a nut directly on the inner sleeve. The method to be used would depend on the installation conditions in each case.

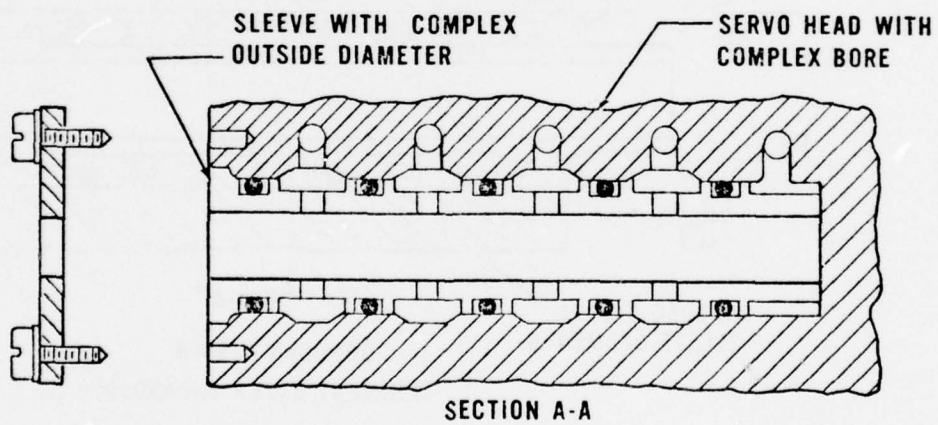
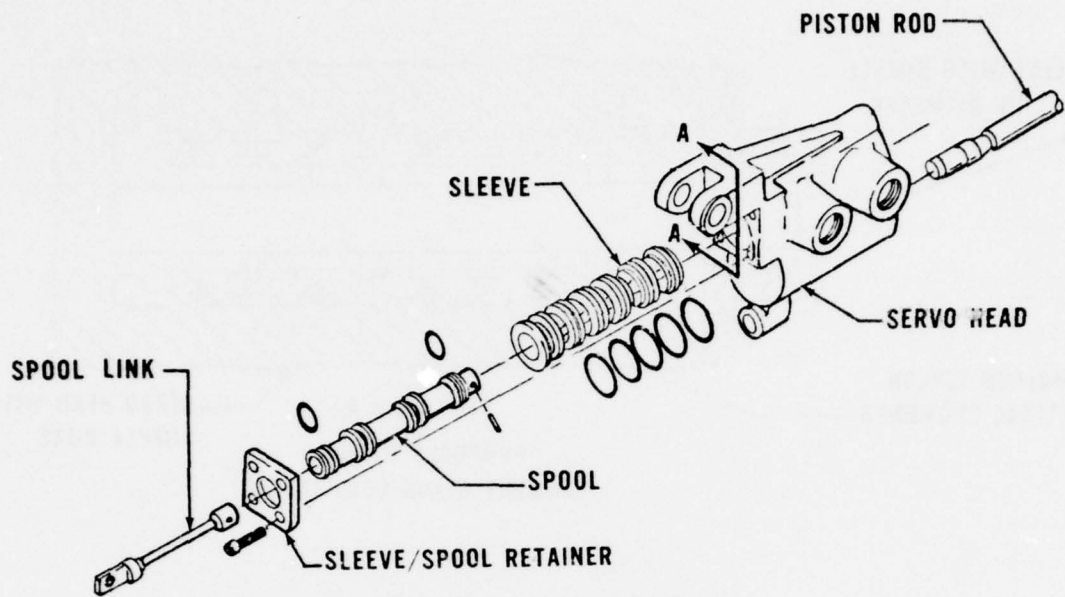
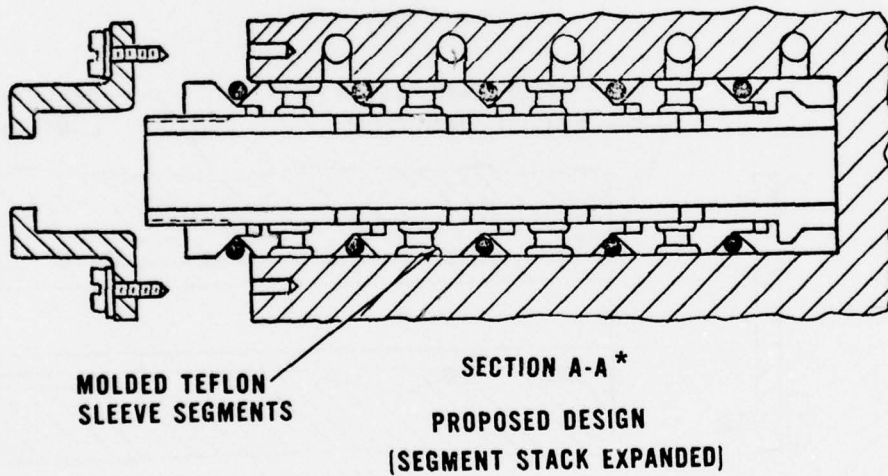
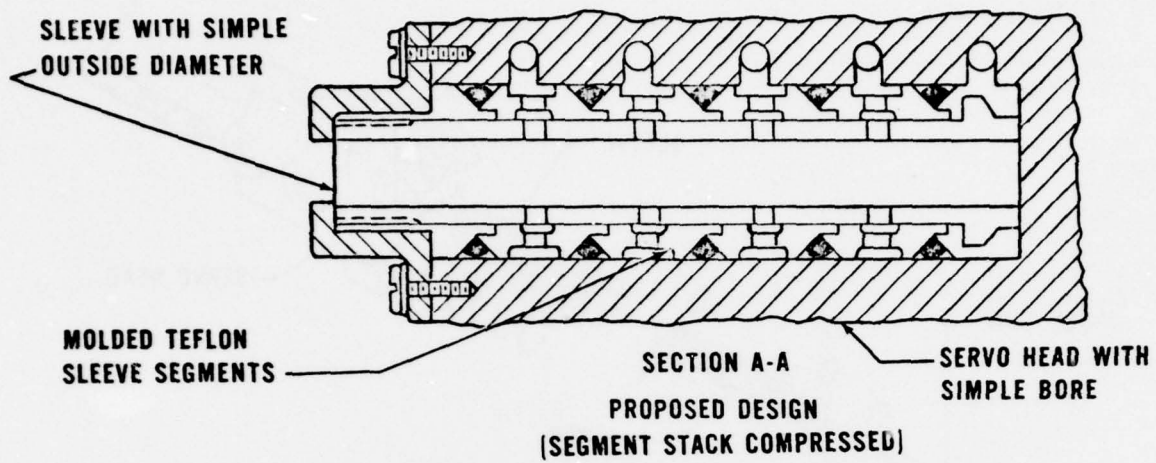

Figure 33. Typical hydraulic actuator design.



\* See Figure 33.

Figure 34. Segmented servo head sleeve.

A candidate material for the sleeve segments is nylon or Teflon, which could be readily molded to the required shape. These materials would also be sufficiently resilient to form the secondary seal required between the segments and the sleeve.

Benefits. Some development work would be required to optimize the seal and segment proportions, including analysis, prototype fabrication and test. In view of the small size and relative simplicity of the parts, it is not anticipated that this would entail great expense.

Cost per valve installation should be lower for the suggested design, by virtue of eliminating the multiple undercuts from both the bore and the sleeve. If the sleeve segments can be produced as plastic moldings, their production cost should be low. Effect on weight would be negligible.

The repair task should be considerably eased with the suggested design because of the reduced installation and removal loads, and the reduced risk of seal damage during installation. This lessening of installation damage to the seals should also enhance component reliability, since such damage frequently results in premature failure of operational components.

Peralties. There is some risk that a seal system meeting all of the performance demands of high-pressure hydraulic equipment could not be achieved, but this risk is viewed as small.

SURVEY RESULTS

STATIC SEALS

Included in this generic group of parts are preformed packings (or O-rings) and flat gaskets used for sealing the parting surfaces between metal covers, housings, etc. O-rings are finding increased use in applications formerly satisfied with gaskets, primarily because of their low cost, wide availability and versatility.

REPAIR TIME DATA AND FIELD-REPORTED PROBLEMS

Only a few static seals are replaced frequently enough to fall within the classification of a significantly occurring repair action. Table 13 lists repair time data for four seals of this

TABLE 13. REPAIR TIME DATA, STATIC SEALS						
Model	Component/Part		Elements of Replacement Task			
			Total Task Time	Dis-assy. and Assy.	Adjst, Align, Etc.	Drain, Lube, Service
UH-1/ AH-1	Main Transmission (Chip Detector Seal)	Hrs. Pct.	0.2	0.1 50.0		0.1 50.0
UH-1	Main Rotor Hub (Grip Reservoir Seal)	Hrs. Pct.	0.6	0.4 66.7		0.2 33.3 0.1 16.7
UH-1	Main Rotor Hub (Trunnion Resv. Seal)	Hrs. Pct.	0.7	0.5 71.4		0.1 14.3 0.1 14.3
CH-47	Combining Transmission (Oil Reservoir Gasket)	Hrs. Pct.	4.9	4.0 81.6		0.2 4.1 0.7 14.3
	Weighted Average	Hrs. Pct.	0.4	0.3 75.0		0.1 25.0

type. The first three involve static O-rings that are replaced in less than one man-hour each. The last repair involves a flat gasket for a CH-47 reservoir that requires approximately five hours to replace, the only static seal with which field personnel reported a problem.

Number of Fasteners (CH-47)

To replace the oil reservoir gasket on the CH-47 combining transmission, the mechanic must remove and reinstall nuts on twenty-four attachment studs (Figure 35). However, considering the design of the reservoir, a three-cavity casting with a flat plate for a cover, a simpler method of attachment is not obvious.

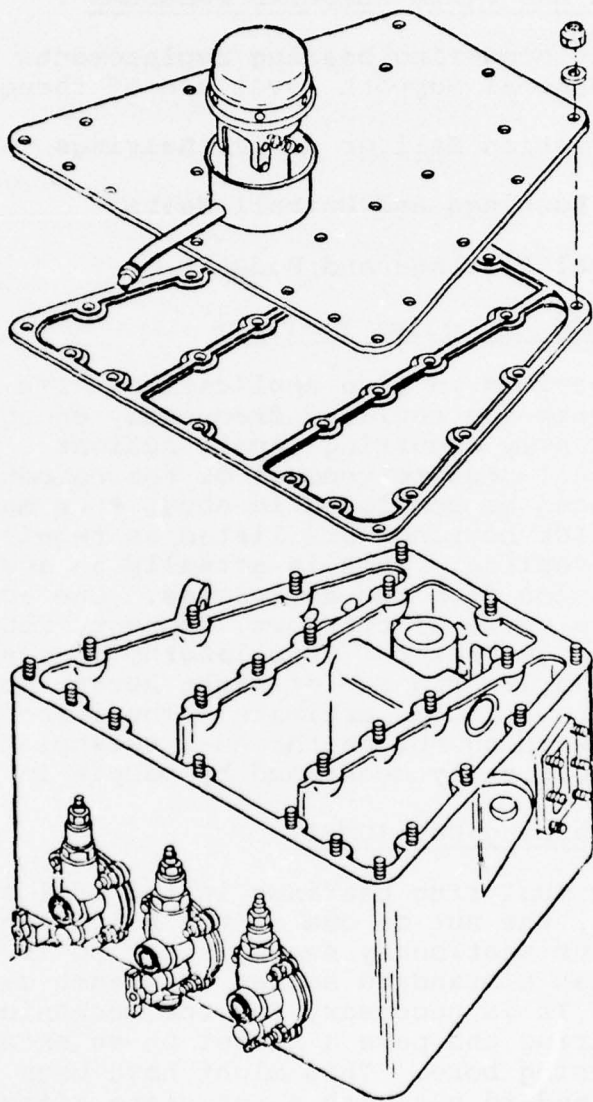

Figure 35. Reservoir cover attachment studs, CH-47 combining transmission.

## SURVEY RESULTS AND DESIGN STUDY

### BEARINGS AND BEARING SURFACES

Although this study concentrated on a list of dynamic components which inherently incorporate many bearings, field interviews revealed that few are replaced short of depot level.

#### REPAIR TIME DATA AND FIELD-REPORTED PROBLEMS

The significantly occurring bearing replacements at Organizational through General Support level are of three types:

1. Anti-Friction Ball or Roller Bearings
2. Teflon Bushings and Uniball Seats
3. Spherical Bearings and Rodends

#### Anti-Friction Ball or Poller Bearings

Anti-friction bearings in five applications with only three types of components are replaced frequently enough to be considered significantly occurring repair actions. Table 14 lists these actions. All require removal of the component for shop repair and most can be completed in about four man-hours. The UH-1/AH-1 generator bearings are listed as requiring over twelve hours to replace. This is actually an average value based on information from two activities. One activity performed a complete cycle of teardown, inspect, repair and test on every incoming generator. This lengthy process included a post-repair vari-drive rig run of eight hours, which is included in the repair time estimate. The inaccessibility of a gimbal ring retaining nut on the AH-1 swashplate was the only problem specifically mentioned by people in the field.

#### Inaccessible Retaining Nut (UH-1)

When replacing gimbal ring bearings in the UH-1 swashplate and support assembly, the nut on one of the bolts securing the gimbal ring to the stationary swashplate ring is inaccessible to the extent that a standard socket or wrench cannot engage it (Figure 36). It is necessary for the mechanic to remove the trunnion bearing and pass a socket on an extension through the trunnion housing bore. This might have been avoided by replacing the standard nut with a nut plate affixed to the stationary swashplate ring. The bolt would be passed through the gimbal ring bearing and thread into or out of the nut plate.

TABLE 14. REPAIR TIME DATA, ANTI-FRICTION BALL OR ROLLER BEARINGS

Model	Component/Part		Elements of Replacement Task					Component Repl. Time *
			Total Task Time	Dis-assy. and Assy.	Adjst. Align. Etc.	Drain Lube Service	In-spect and Test	
OH-58	Swashplate (Duplex Bearing)	Hrs.	3.3	2.0	0.7	0.1	0.5	6.2
		Pct.		60.6	21.2	3.0	15.2	
AH-1	Swashplate (Large Duplex Bearing)	Hrs.	6.7	5.5	0.4	0.1	0.7	7.5
		Pct.		82.1	6.0	1.5	10.4	
UH-1	Swashplate (Gimbal Ring Bearing)	Hrs.	3.3	2.7	0.3		0.3	10.0
		Pct.		81.8	9.1		9.1	
UH-1	Tail Rotor Hub (Duplex Thrust Bearing)	Hrs.	3.6	1.7	1.4	0.1	0.4	3.5
		Pct.		47.2	38.9	2.8	11.1	
AH-1	Tail Rotor Hub (Duplex Thrust Bearing)	Hrs.	3.6	1.7	1.4	0.1	0.4	3.6
		Pct.		47.2	38.9	2.8	11.1	
UH-1	Tail Rotor Hub (Trunnion Brg. & Hsng.)	Hrs.	3.1	1.5	1.3	0.1	0.2	3.5
		Pct.		48.4	41.9	3.2	6.5	
AH-1	Tail Rotor Hub (Trunnion Brg. & Hsng.)	Hrs.	3.1	1.5	1.3	0.1	0.2	3.6
		Pct.		48.4	41.9	3.2	6.5	
OH-58	Starter/Generator (Armature Bearings)	Hrs.	4.0	3.0			1.0	2.0
		Pct.		75.0			25.0	
UH-1	Starter/Generator (Armature Bearings)	Hrs.	12.6	7.0	0.1		5.5	3.2
		Pct.		55.6	0.8		43.7	
UH-1	D.C. Generator (Armature Bearings)	Hrs.	12.6	7.0	0.1		5.5	2.7
		Pct.		55.6	0.8		43.7	
AH-1	Starter/Generator (Armature Bearings)	Hrs.	12.6	7.0	0.1		5.5	3.3
		Pct.		55.6	0.8		43.7	
Weighted Average		Hrs.	6.6	4.1	0.4		2.1	
		Pct.		62.1	6.1	0.0	31.8	

\* Off-aircraft tasks.

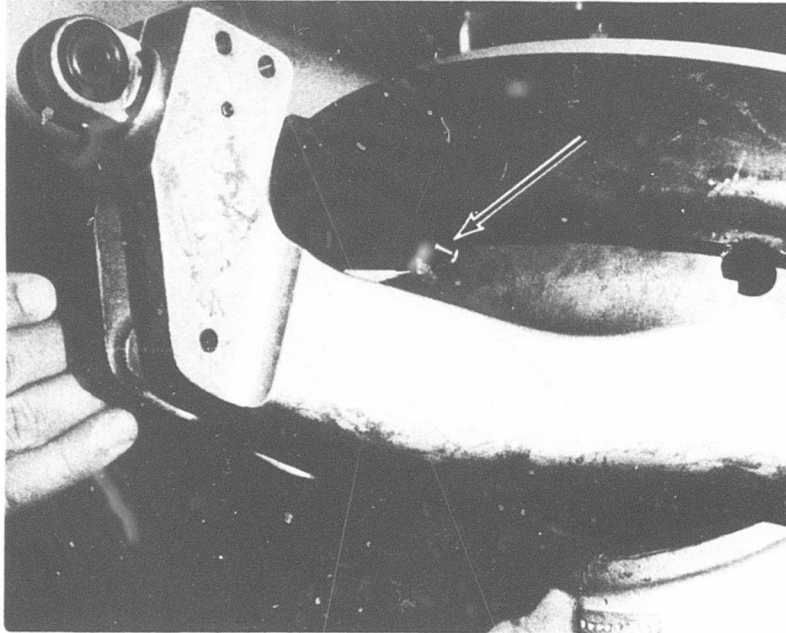

Figure 36. Gimbal ring attachment bolt and nut, UH-1 swashplate.

#### Teflon Bushings and Uniball Seats

Teflon bushings in the OH-58 tail rotor hub and the AH-1 main rotor hub are the most frequently replaced bearings of this type according to field survey results. In both cases, the hubs are brought to a shop for disassembly, and it is common practice to replace all bushings in the hubs at that time. This practice, plus the requirement for several people to restrain the AH-1 hub while breaking or applying high bolt torques, accounts for the relatively high man-hour expenditures listed in Table 15. A second type of Teflon bearings, replaced less frequently, are swashplate uniball seats. The much shorter replacement for the CH-47 uniball seats, compared with that of the OH-58 and AH-1, results from the fact that the CH-47 swashplate is separated from its control slider guide upon removal from the aircraft, whereas this disassembly must be done in the shop with the other two aircraft.

For several of these repair tasks, problems with post-repair adjustments, balancing and high bolt torques were reported by mechanics in the field.

TABLE 15. REPAIR TIME DATA, TEFLON BUSHINGS AND UNIBALL SEATS

Model	Component/Part		Elements of Replacement Task					Component Repl. Time*
			Total Task Time	Dis-assy. and Assy.	Adjst, Align, Etc.	Drain Lube Ser-vice	In-spect and Test	
OH-58	Tail Rotor Hub (Trunnion Thrust Bsng.)	Hrs.	2.9	2.0	0.7		0.2	5.4
		Pct.		69.0	24.1		6.9	
OH-58	Tail Rotor Hub (Teflon Brg. & Hsng.)	Hrs.	3.6	2.5	0.9		0.2	5.4
		Pct.		69.4	25.0		5.6	
AH-1	Main Rotor Hub (Trunnion Teflon Brgs.)	Hrs.	7.2	6.0	0.9		0.3	6.9
		Pct.		83.3	12.5		4.2	
AH-1	Main Rotor Hub (Grip Teflon Brgs.)	Hrs.	9.7	8.0	1.4		0.3	6.9
		Pct.		82.5	14.4		3.1	
OH-58	Swashplate (Uniball Teflon Seats)	Hrs.	5.4	4.0	0.7		0.7	6.2
		Pct.		74.1	13.0		13.0	
AH-1	Swashplate (Uniball Teflon Seats)	Hrs.	5.1	4.0	0.5	0.1	0.5	7.5
		Pct.		78.4	9.8	2.0	9.8	
CH-47	Swashplate (Uniball Teflon Seats)	Hrs.	1.3	1.0			0.3	14.1
		Pct.		76.9			23.1	
CH-47	Swashplate (Slider Teflon Brgs.)	Hrs.	9.0	8.1	0.1		0.8	14.1
		Pct.		90.0	1.1		8.9	
CH-54	Swashplate (Teflon Brgs., Scissors)	Hrs.	6.8	5.0			1.8	
		Pct.		73.5			26.5	
AH-1	Hydraulic Actuator (Uniball Seats)	Hrs.	5.2	2.2	0.3	0.1	2.6	3.2
		Pct.		42.3	5.8	1.9	50.0	
Weighted Average		Hrs.	4.3	3.1	0.5		0.7	
		Pct.		72.1	11.6	0.0	16.3	

\* Off-aircraft tasks.

Handling Damage (AH-1)

When the spherical seats for the uniball in the AH-1 swashplate have been removed (Figure 37), the uniball is completely exposed and vulnerable to handling damage. The ball is easily scratched or nicked, and the smallest amount of damage is cause for returning the unit to depot for evaluation. A ceramic

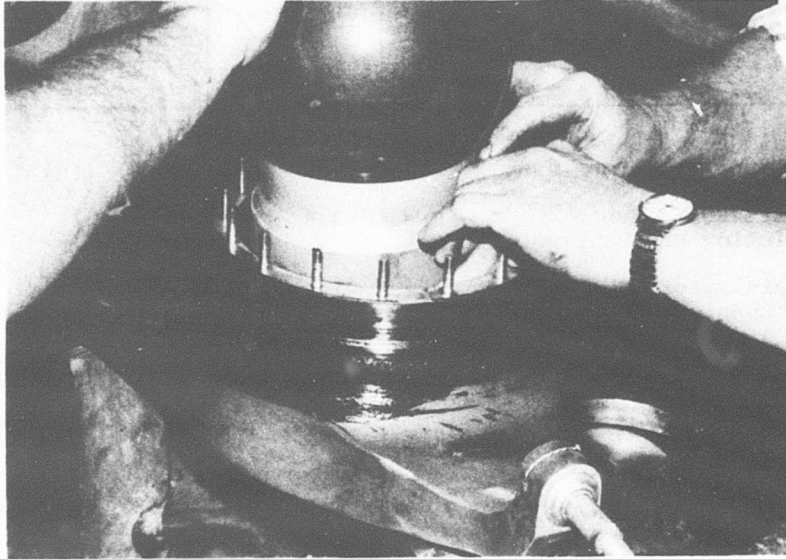

Figure 37. Removal of uniball spherical seats, AH-1 swashplate.

coating for uniballs of this type might be considered as one method of improving the resistance to surface damage. Ceramic would also provide a low friction, long-wearing bearing surface.

#### Friction Adjustment (AH-1)

After replacing the spherical seats for the uniball in the AH-1 swashplate, it is necessary to adjust friction on the ball by altering the thickness of the shim stack between the spherical seat halves. The shims are segmented and installation of different thickness segments occasionally occurs. Obtaining proper friction is essentially a trial-and-error process, and often two or three attempts are needed before the proper adjustment is obtained. It is time-consuming, as well, in that sixteen individual nuts (Figure 38) are torqued in the process of making the adjustment. Concepts for simplifying the friction adjustment on swashplate uniballs of this type are examined later in this section of the report.

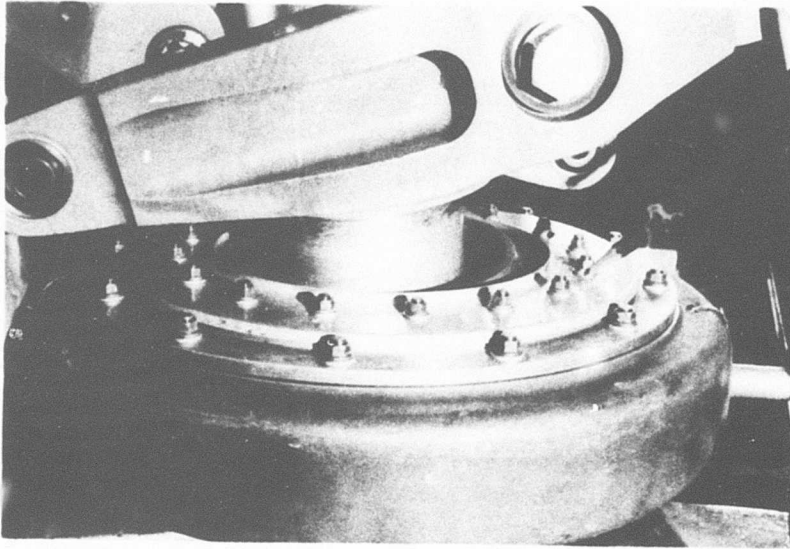

Figure 38. Uniball friction adjustment, AH-1 swashplate.

#### Torque Application Problem (AH-1)

Torquing the hub extension bolts (Figure 39) following replacement of grip bearings in the AH-1 main rotor hub is difficult because the hub cannot be effectively restrained. Application of the 450- to 500-ft-lb torque requires four men: one to hold the socket engaged on the nut, another to operate the torque wrench, and two others to restrain the hub. Figure 40 shows the task in process. The need for the two men restraining the hub might be eliminated if the rotor support bench (special tool) were modified to incorporate a male spline for engagement with the hub spline and if provisions were made for bolting the support bench to the shop floor. (The tool presently has a smooth diameter over which the hub spline is positioned, which provides no restraint whatever.) A third man might be eliminated by using a standard torque multiplier with special adapters that would engage the bolt head and nut in the same setup.

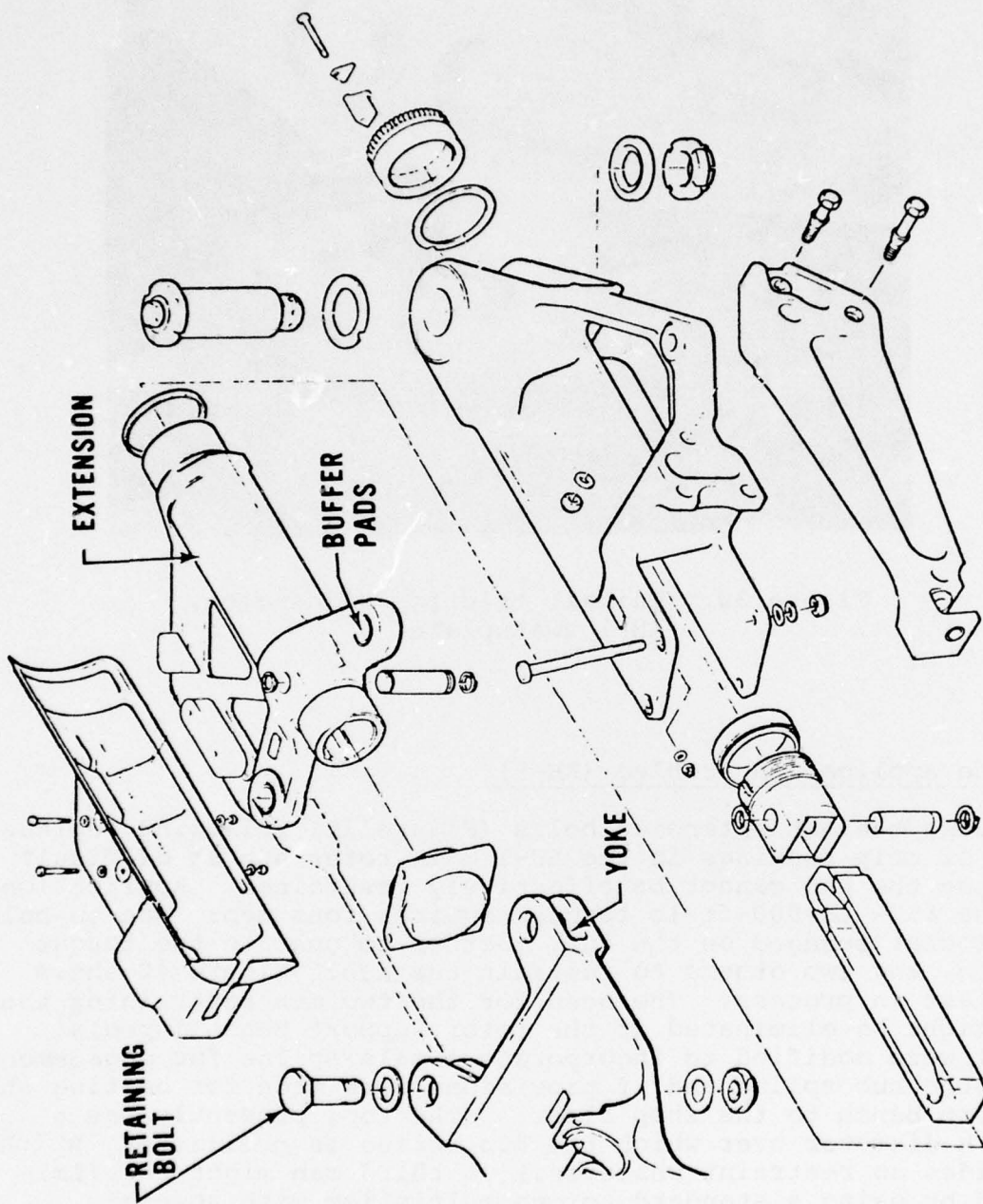

Figure 39. Exploded view, AH-1 main rotor hub.



Figure 40. Removal of extension-to-yoke attach bolts, AH-1 main rotor hub.

#### Balancing Requirement (OH-58)

After replacing trunnion thrust bushings or Teflon bearings in the OH-58 tail rotor hub, the tail rotor must be balanced. Mechanics complain that the static balancer provided for the OH-58 is not accurate, i.e., does not give repeatable balance indications. They state that a different indication can be obtained when the same rotor, without any weight change, is placed on the balancer for a second time. Most mechanics prefer the Marvel static balancer or the Hughes dynamic balancer for the OH-6, which uses a strobe light (Figure 41).

#### Spherical Bearings and Rod Ends

Helicopter control systems incorporate many spherical bearings and rod ends that commonly experience high replacement rates. Most of these items were not included with the components covered by this study, however. Table 16 lists only three bearings of this type as significantly occurring repair actions. CH-54 main rotor damper bearings are off-aircraft replacements. A post-replacement rigging requirement accounts for more than half the time listed for CH-54 tail rotor pitch link rod ends, one of two problems reported by people in the field.

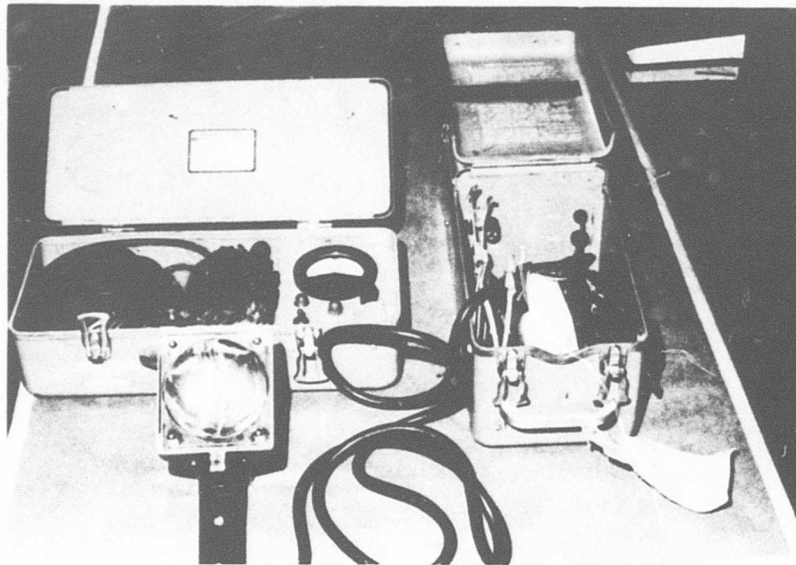

Figure 41. Dynamic balancer, OH-6 tail rotor.

TABLE 16. REPAIR TIME DATA, SPHERICAL BEARINGS AND ROD ENDS

Model	Component/Part		Elements of Replacement Task				Component Repl. Time*	
			Total Task Time	Dis-assy. and Assy.	Adjst. Align, Etc.	Drain Lube, Ser-vice		In-spect and Test
UH-1	Swashplate (Trunnion Bearings)	Hrs. Pct.	0.6	0.4 66.7		0.1 16.7	0.1 16.7	
CH-54	Main Rotor Head (Damper Bearings)	Hrs. Pct.	1.1	0.4 36.4			0.7 63.6	3.2
CH-54	Tail Rotor Head (Pitch Link Rodend)	Hrs. Pct.	1.7	0.5 29.4	1.0 58.8		0.2 11.8	
Weighted Average		Hrs. Pct.	1.1	0.4 36.4	0.1 9.1	0.0	0.6 54.5	

\* Off-aircraft tasks.

### Oil Line Obstruction (CH-54)

In order to replace the bearing on the CH-54 main rotor head damper, a flexible oil line must be removed from the damper. There is a standard fitting at the damper and a quick-disconnect fitting at the opposite end which attaches to a ring at the accumulator. When the line is broken at the quick-disconnect, oil is lost from the accumulator, primarily, mechanics believe, because of the slow action of the disconnect (eight to ten turns required before separation is complete). When the line is disconnected at the damper, the oil in the line and some of the oil in the damper is lost, requiring that the system be serviced after the line is replaced.

The need to remove the oil line to obtain access to the damper bearing might have been avoided if the line had been routed differently during initial design. The problem with the quick-disconnect might be eliminated through selection of one of the fast-acting, positive-seating type disconnects available.

### Rigging Requirement (CH-54)

After replacing a pitch change link or a pitch change link rod end on the CH-54 tail rotor, it is necessary to rig the tail rotor controls. Rigging requires the use of a hydraulic mule and takes approximately one man-hour to complete. The rigging requirement might have been avoided if the pitch change links were made fixed-length and the control length adjustment was designed elsewhere in the system, preferably at the disconnection having the lowest incidence of maintenance.

### DESIGN STUDIES

Two concepts for eliminating the time-consuming and error-prone process of adjusting uniball friction with one of the current swashplate designs were studied. One of the concepts replaces the involved shimming arrangement of the present design with a threaded ball seat which vastly simplifies the friction adjustment. The need for adjusting friction is eliminated entirely by the second concept which removes the collective control loads from the ball via a gimbal arrangement and provides the required preload with a spring-loaded seat. A concept for using pressure, supplied via a standard grease fitting, to ease the removal of heavy press fit bearings and tapered pins was also studied.

#### Swashplate Uniball With Threaded Seats

The time-consuming, trial and error process of adjusting uniball friction on one current swashplate design could be substantially improved with the use of a threaded ball seat.

With this concept, shown in Figure 42, the upper ball seat is adjusted axially by means of a threaded sleeve. In order to provide the required fine adjustment, the sleeve is threaded with a 16-pitch internal thread and an 18-pitch external thread, resulting in .007 inch of motion for one revolution of the sleeve.

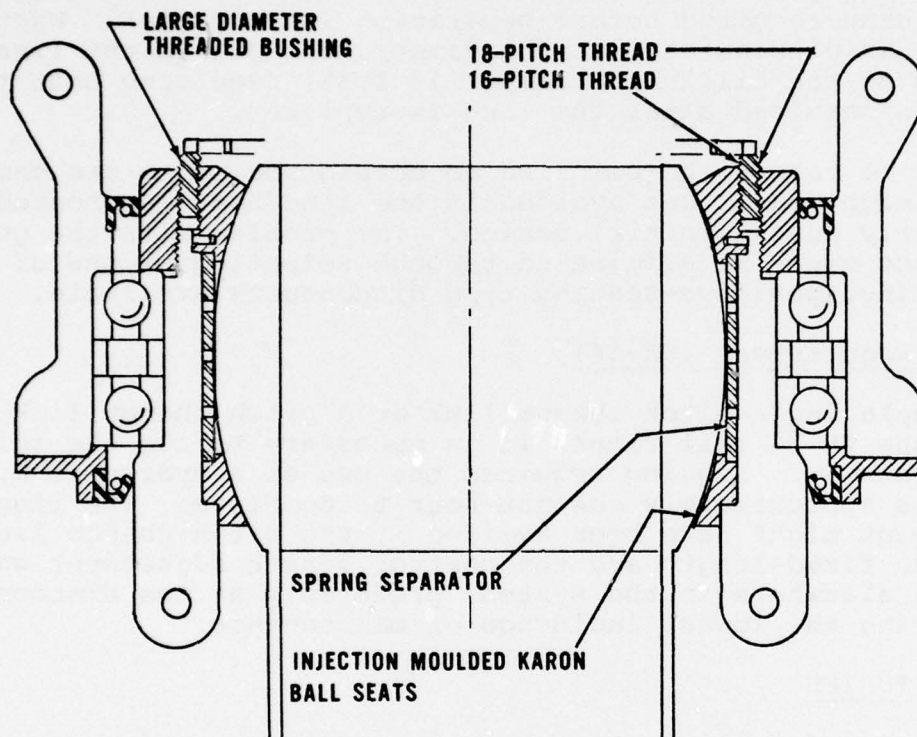

Figure 42. Swashplate uniball with threaded seats.

The ball seats in the proposed design are injection molded KaRon material. By making use of the unique Kamatics process of molding the KaRon in place, an accurate fitup can be achieved in new bearings, which compensates for assembly tolerances. The fine adjustment is then used to accommodate slight wear which might occur in use.

Benefits. Little risk is seen in an undertaking to develop a swashplate of this proposed design. KaRon bearings have been made and tested in a variety of applications and sizes, and their characteristics are well known. The major benefit of the design is a substantial savings in man-hours, both for initial

manufacture and for subsequent disassembly for maintenance. No greater maintenance skill level would be required, and the present "Murphy" of installing shim segments of differing thickness is eliminated.

Penalties. Initial cost would be higher with this design, due to the incorporation of the double threaded sleeve. However, overall life-cycle costs should diminish because of maintenance time savings. Weight may also increase slightly.

#### Unloaded Uniball With Spring Seat

Figure 43 shows a scheme for maintaining swashplate ball preload by means of a spring-loaded ball seat (rather than the shim adjusted seat of the existing design). The spring could be installed at a fixed height, eliminating the need for adjustment.

The success of such a scheme depends on the absence of control system loads which might overcome the preload of the spring, introducing backlash into the control system. To assure that large reversing loads are not carried through the ball, it is necessary to carry all control loads through a gimbal arrangement on the stationary swashplate ring. Presently, collective loads are transmitted through the ball. The figure illustrates the arrangement that would be required with the spring-loaded ball seat.

Benefits. Development risk should be slight, depending only on the ability to correctly define the preload needed between the ball and seats. Design of the spring and its pocket is straightforward, with reliably predictable results. Cost of the proposed swashplate assembly should be comparable to the cost for the current design. Any cost increase due to control system complexity would have to be evaluated on the basis of the specific helicopter control system design. The same is true for weight.

Since proper ball preload would be maintained in spite of moderate seat wear, the need for replacement of the ball and seats would be greatly reduced. Assembly of the swashplate either with used or new parts requires no adjustment, eliminating what is presently a very time-consuming procedure, demanding considerable skill.

Penalties. Adoption of the proposed scheme does involve some added complexity in control system design, with attendant increases in weight and cost and, perhaps, maintenance. The impact of that complexity is very dependent on the arrangement of the control system below the swashplate, ruling out a blanket evaluation of this factor for the proposed design.

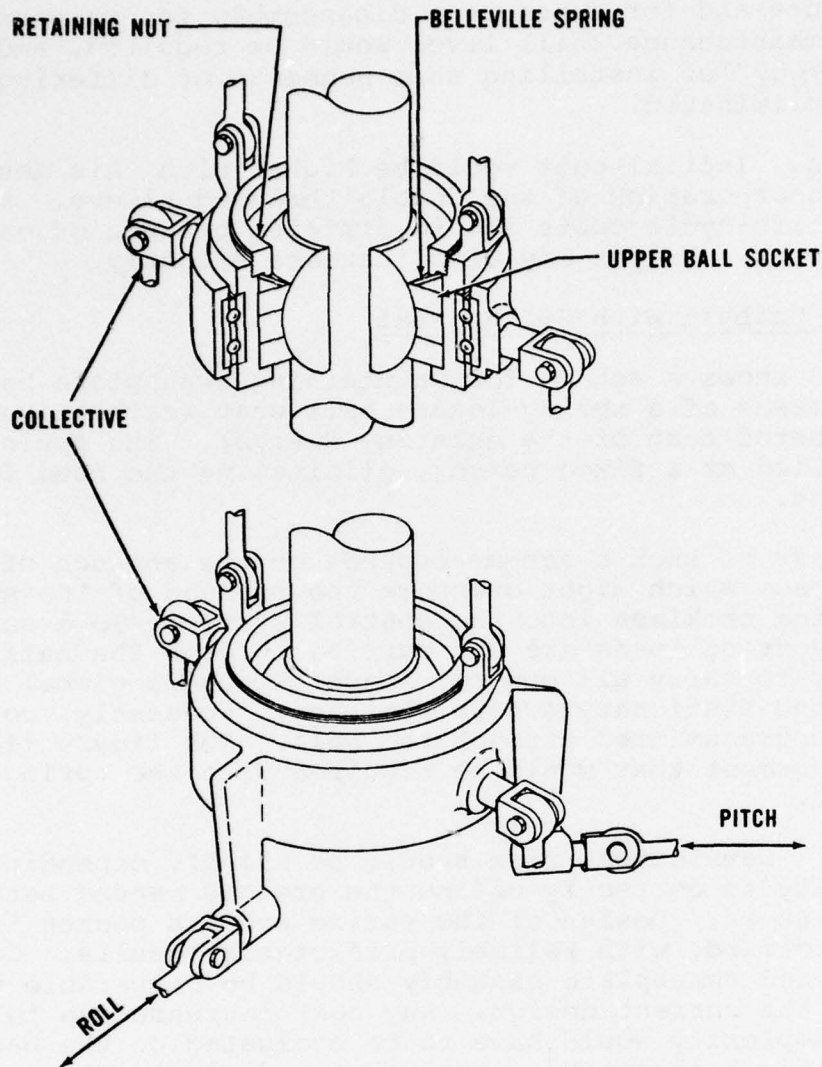

Figure 43. Unloaded swashplate uniball with spring seat.

#### Grease Fitting for Bearing Removal

In some installations, it is necessary to remove a heavy press fit, large-diameter bearing, in order to replace a seal. The upper rotor mast of the UH-1 is a case in point. In order to overcome the fit of the bearing on the shaft, extremely high forces are applied, often resulting in damage to the bearing and sometimes to the puller. One concept for easing the removal of these bearings employs a grease fitting and an annular groove in the shaft under the bearing inner race (Figure 44). To remove the bearing, grease is pumped under

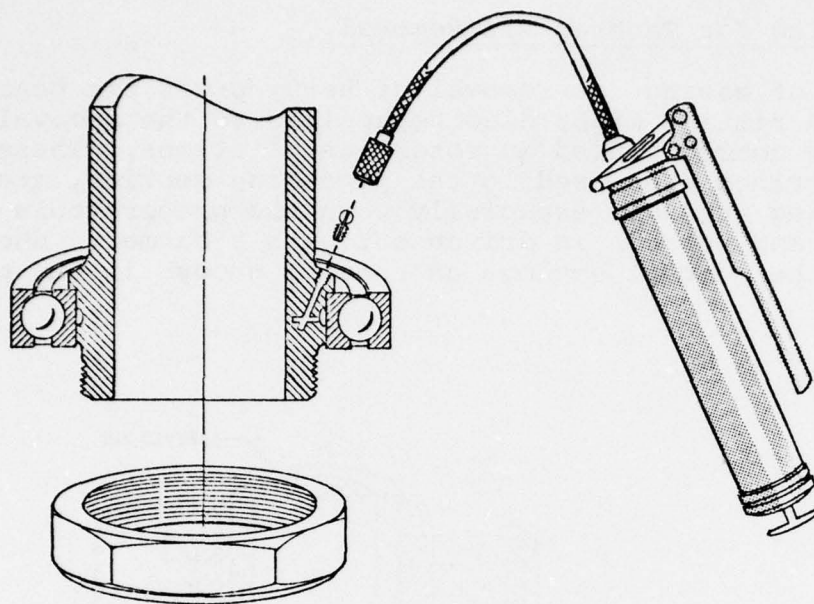

Figure 44. Grease fitting for bearing removal.

pressure, into the groove, slightly expanding the inner race and relieving the fit. The puller is required to exert much less force, and damage to the bearing (and puller) is avoided. A plug would replace the grease fitting when the shaft is installed in the aircraft.

Benefits. The major advantage of this concept, aside from easing the bearing removal task, is the savings that would result from salvaging the many bearings that are presently being scrapped because of damage. (This type of design has already been used on the H-2 helicopter.)

Penalties. Some additional cost will be incurred as a result of machining the groove and passageway in the shaft. Weight will also probably increase, due to the wall reinforcement that would be needed to counteract the stress risers created by the machining. The concept also incorporates a "Murphy", in that the grease fitting, if not removed prior to placing the shaft back into supply, might inadvertently be used to pump grease into the groove during aircraft maintenance (a mechanic

mistaking it for a lube fitting). This would reduce the fit of the bearing on the shaft and apply an added preload to the bearing balls or rollers.

#### Grease Fitting for Tapered Pin Removal

The concept of easing the removal of heavy press fit bearings via a grease fitting might also be applied to the removal of tapered pins commonly used in rotor installations. These pins, like the bearings discussed in the preceding section, are often damaged during removal, especially when the proper tools are unavailable and the pin is driven out with a hammer. Shown in Figure 45, the concept employs an annular groove in the pin

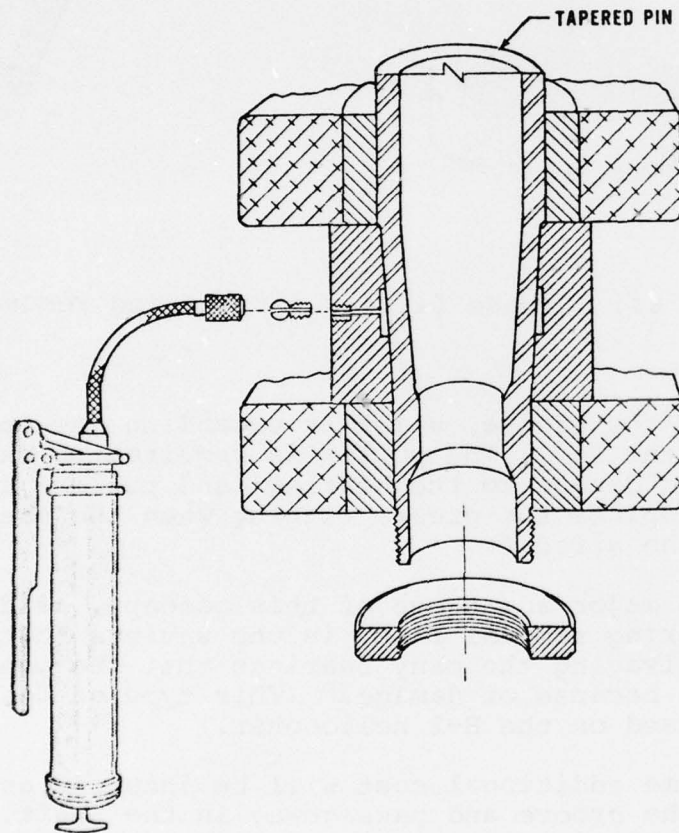

Figure 45. Grease fitting for tapered pin removal.

bore and a standard grease fitting. Grease pumped under pressure into the groove applies a compressive force to the wall of the pin and also an upward component, aided by the taper, acting to loosen the fit. The pin is removed with a standard puller, using much lower force than previously required.

Benefits. This concept, similar to the bearing application, eases the replacement of tapered pins and reduces the frequency of damage and scrap.

Penalties. The concept suffers the same penalties in this application as those described for the bearing application in the preceding section.

## SURVEY RESULTS AND DESIGN STUDY

### OIL LEVEL SIGHT GLASSES

There are essentially two types of oil level sight glasses repaired in the field. The first, and most widely used, is a clear plastic plug threaded on its outside diameter or retained via a snap ring in the gearbox or rotor head housing. The second type, used primarily on CH-47 gearboxes, is a clear plastic plate secured via a series of screws around its periphery. Some sight glasses use reflective surfaces immersed in the oil behind the window to enhance visualization of the oil surface in poor light. A more recent innovation uses a polished floating sphere to improve oil surface detection. The most common transparent medium is "Pyrex" glass, which is capable of withstanding the high temperatures usual in many lubricating systems. Clear plastic is used where lower temperatures permit.

### REPAIR TIME DATA AND FIELD-REPORTED PROBLEMS

Table 17 summarizes the collected repair time data on oil level sight glasses. All of the sight glasses covered by the study are replaced on the aircraft in one man-hour or less, with the exception of the type used on the CH-47, which requires closer to two man-hours, on an average, to replace. The very limited data collected on the OH-6 helicopter did not cover sight glass replacements. Sight glasses on the CH-54 intermediate and tail rotor gearboxes are replaced at rates low enough not to be considered significantly occurring. In lieu of sight glasses, the CH-54 incorporates a dip stick in its main transmission and transparent reservoirs on its main and tail rotors.

Oil level sight glasses rank high among the frequently replaced parts in the repair tasks covered by this study. The man-hours consumed in the replacement of these items is related more to the poor durability of these units in service, however, than it is to the time required for the repair task. The lack of durability stems primarily from the discoloration of the glass which tends to occur over time due to prolonged exposure to oil at elevated temperatures. In extreme cases, this staining can be mistaken for a spurious oil level indication in the tank. When the glass becomes stained and no longer transparent, it must be disassembled and cleaned, or replaced. Some problems with replacement of sight glasses were reported by the people in the field. Maintenance-induced damage, poor accessibility and post-repair servicing time were among those cited.

TABLE 17. REPAIR TIME DATA, OIL LEVEL SIGHT GLASSES

Model	Component/Part		Elements of Replacement Task				
			Total Task Time	Dis-assy. and Assy.	Adjst. Align. Etc.	Drain, Lube, Ser-vice	In-spect and Test
OH-58	Main Transmission	Hrs. Pct.	0.3 33.3	0.1 33.3		0.1 33.3	0.1 33.3
OH-58	Tail Rotor Gearbox	Hrs. Pct.	0.3 33.3	0.1 33.3		0.1 33.3	0.1 33.3
UH-1/ AH-1	Main Transmission	Hrs. Pct.	0.6 50.0	0.3 50.0		0.2 33.3	0.1 16.7
UH-1/ AH-1	Intermediate Gearbox	Hrs. Pct.	0.5 60.0	0.3 60.0		0.1 20.0	0.1 20.0
UH-1/ AH-1	Tail Rotor Gearbox	Hrs. Pct.	0.5 60.0	0.3 60.0		0.1 20.0	0.1 20.0
CH-47	Fwd. Transmission	Hrs. Pct.	1.8 44.4	0.8 44.4		0.7 38.9	0.3 16.7
CH-47	Aft Transmission	Hrs. Pct.	1.9 42.1	0.8 42.1		0.8 42.1	0.3 15.8
CH-47	Combining Transmission	Hrs. Pct.	1.6 37.5	0.6 37.5		0.8 50.0	0.2 12.5
OH-58	Main Rotor Hub	Hrs. Pct.	0.4 50.0	0.2 50.0		0.1 25.0	0.1 25.0
CH-47	Rotor Head	Hrs. Pct.	1.0 10.0	0.1 10.0		0.8 80.0	0.1 10.0
Weighted Average		Hrs. Pct.	0.7 42.9	0.3 42.9		0.3 42.9	0.1 14.3

Access Problem (CH-47)

Access to the oil level sight glass on the CH-47 forward transmission is limited due to the proximity of the fuselage structure (Figure 46). Restricted access would be less of a problem if the sight glass itself were more easily removed and installed. One approach would use a "vee" band clamp having a single

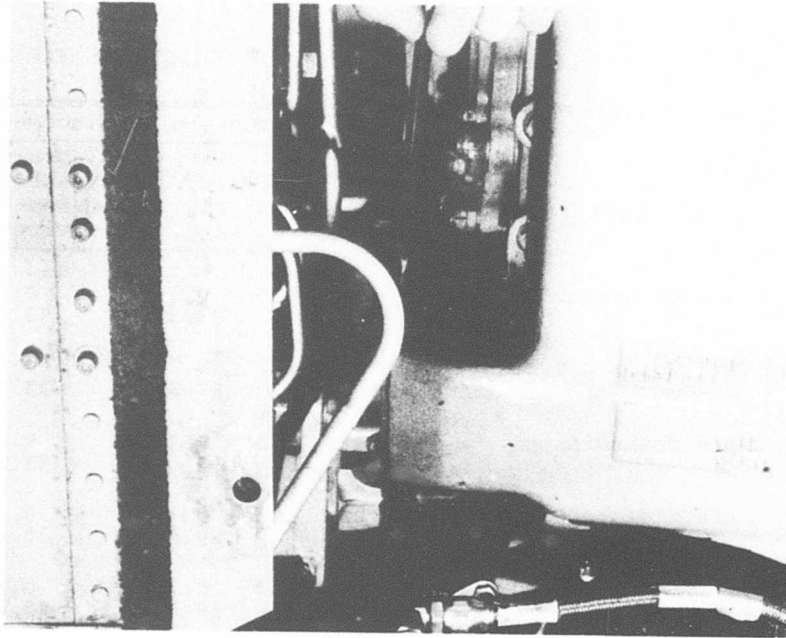

Figure 46. Sight glass window inaccessibility, CH-47 forward transmission.

fastener to sandwich together a glass disc, a gasket and a flange integral with the transmission housing. This and other concepts are explored later in this section of the report.

#### Sight Glass Damage (OH-58, UH-1, AH-1)

When pulling oil level sight glasses from the transmissions, the intermediate gearboxes and the tail rotor gearboxes of the OH-58, UH-1 and AH-1 helicopters, O-ring friction is too great to overcome with the force of fingers alone. A circumferential groove on the outside diameter of the glass is provided for the attachment of a standard puller. More often, mechanics will use a screwdriver as a prying tool, which results in breaking the glass. One approach to eliminating this problem retains the O-ring for sealing and a snap ring for positive retention, but adds a screw thread on the glass outside diameter and a hex shape to the exposed end. The glass would be screwed into and out of the gearbox housing bore.

Particular caution must be exercised when torquing the single retaining bolt which passes through the center of the oil level

sight glass on the grip reservoir of the OH-58 main rotor hub. Slight overtorque applied when the bolt is warm will cause the glass to break when the bolt contracts at low temperatures. A minor change in design that might eliminate this problem would incorporate a bellville washer (spring) under the head of the fastener to accommodate length changes due to temperature. More preferable would be a design which subjects the glass to compression loads only, eliminating bending loads which tend to break the glass. Other concepts for improving sight glass installations are discussed later in this section of the report.

#### Servicing Problems (UH-1, AH-1, CH-47)

Prior to replacing an oil level sight glass on the CH-47 combining transmission (Figure 47), it is necessary to partially drain the transmission. The task is complicated by the need to temporarily attach a flex hose to the drain valve and route the line down through the cabin roof into the aft cabin. At the expense of additional weight, this problem could have been eliminated by incorporating permanent drain lines to carry the oil overboard.

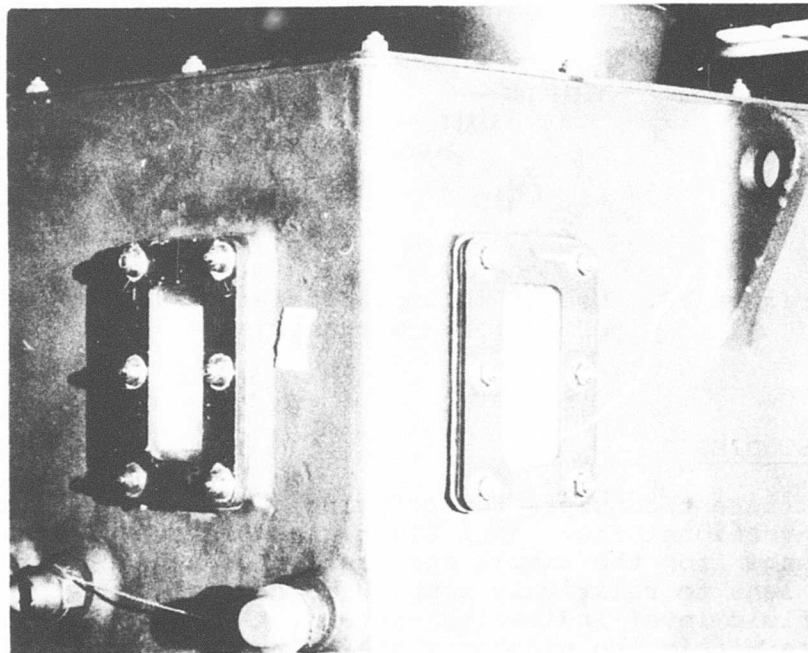

Figure 47. Sight glass windows, CH-47 combining transmission.

After replacing oil level sight glasses in the UH-1 and AH-1 main transmissions, and the CH-47 forward and aft transmissions, it is necessary to service the transmissions with oil. This is a two-man job because the filler ports are widely separated from the sight glasses in each of these installations, and one man cannot fill and simultaneously observe the rise in oil level. Indirect reading oil level indicators that could be positioned adjacent to the filler port are among the design concepts explored in this section of the report.

#### Adhesive Removal (CH-47)

The gaskets used to seal the oil level sight glasses on the forward, aft and combining transmission of the CH-47 adhere to the transmission housings and must be scraped off (Figure 48).

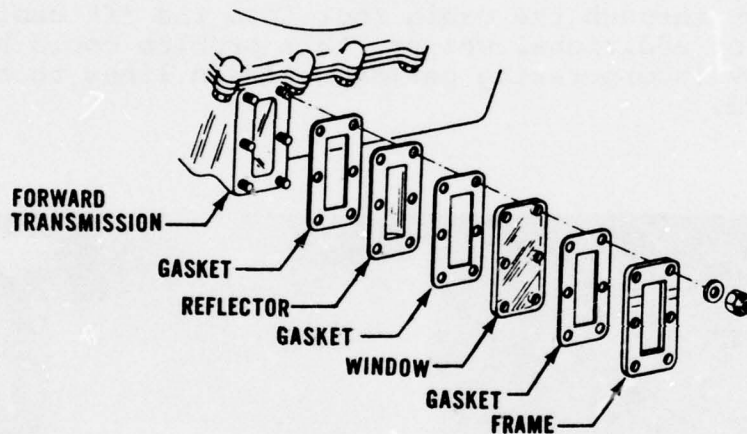

Figure 48. Use of multiple gaskets, sight glass, CH-47 forward transmission.

#### DESIGN STUDIES

Seven different concepts for reducing the maintenance problems with conventional fluid tank sight glasses have been explored. These range from the simple application of a high-contrast fresnel lens to relatively complex mechanical and electronic, remote fluid level indicating systems. All seven of the concepts are within the present state of the art and would involve little development risk. Development costs might be appreciable for the remote indicating systems, however, and several of the concepts present major disadvantages in terms of weight, cost and maintenance complexity.

### Sight Glass With High-Contrast Fresnel Lens

The problem of discoloration of oil level sight glasses, and the frequent cleaning and repair it necessitates, is largely overcome through the use of a high contrast sight gauge employing a fresnel lens (Figure 49). In this type of gauge,

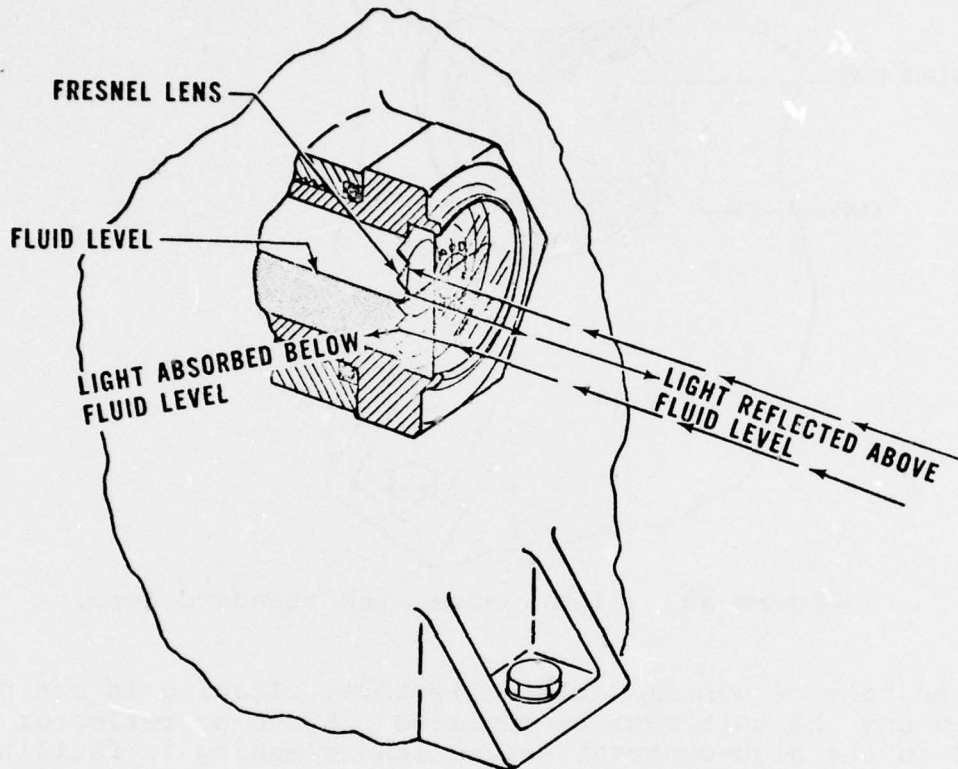

Figure 49. Sight gauge with high-contrast fresnel lens.

90% of the incident light is reflected in the non-immersed portion of the lens, while virtually no light reflects from the portion that is in contact with the fluid, resulting in an excellent definition of the oil level. The conventional gauge (Figure 50), by comparison, reflects 30% to 40% of incident light in the dry portion and, depending on fluid clarity, may reflect 10% to 20% below the fluid level. Staining in the conventional gauge affects both the reflector and the lens, while only the lens can be affected in the high-contrast gauge, and that to a much lesser degree. The useful period between removals for cleaning or replacement should, therefore, be greatly extended.

The high-contrast sight gauge also offers an improvement in repairability. Repair of a conventional sight gauge requires disassembly and cleaning of both the reflector and the lens or,

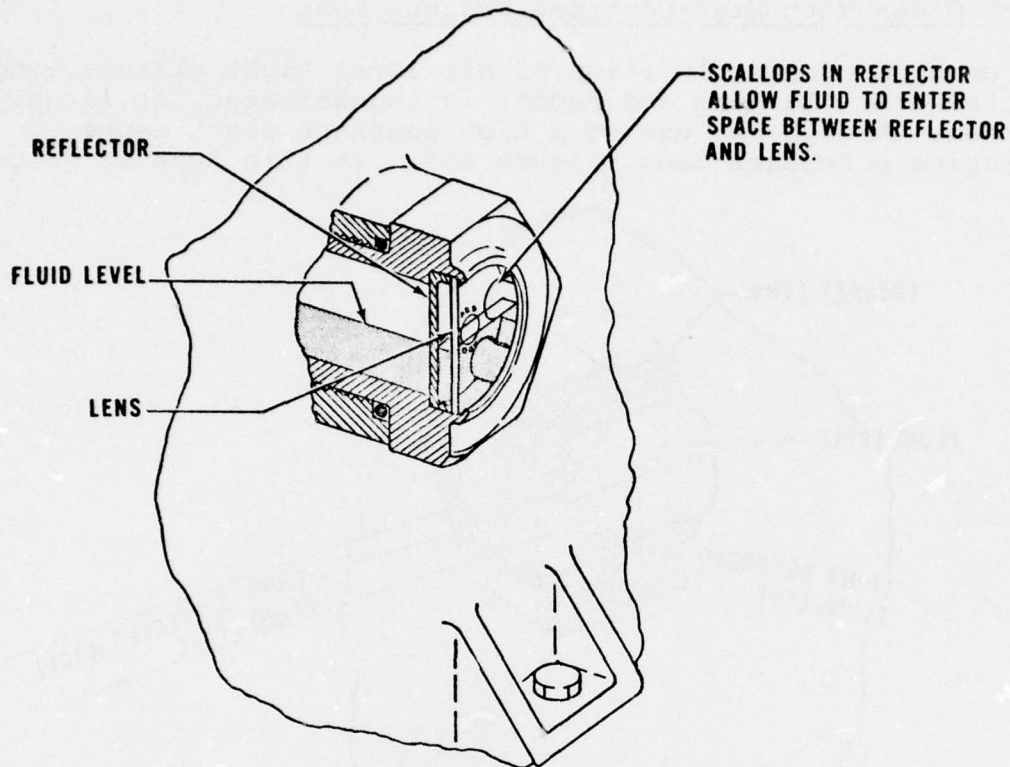

Figure 50. Sight gauge with standard lens.

in the case of nonremovable reflectors, cleaning is not possible and the unit must be replaced. Since no reflector is used in the high-contrast gauge, lens cleaning is facilitated.

Benefits. The high-contrast principle can be applied to circular or elongated gauges, in plastic, pyrex or fused quartz. Its principal advantages are:

1. Appreciably longer intervals between cleaning and repair
2. Improved readability in marginal light or when partially stained
3. Easier cleaning because of the absence of a reflector
4. Availability as a developed item.

Penalties. Only one disadvantage is apparent with the high-contrast sight gauge. Any fluid viewed through the lens will appear very dark, almost black, and the ability to judge oil

condition by way of its color is thereby lost. (It should be noted that a clear sight glass which is stained can mislead a mechanic attempting to discern oil color, as well; so this disadvantage is partially offset.) Cost, weight, repair skill requirements and logistics are not significantly different for the high-contrast gauge.

#### Top Viewing Sight Gauge With High-Contrast Lens

The advantages of the high-contrast sight gauge discussed in the preceding section are also present in a concept for a top viewing gauge of this type. The proposed gauge consists of a clear transparent plastic rod, with a conical end dipping into the oil surface (Figure 51). Prismatic surfaces are molded

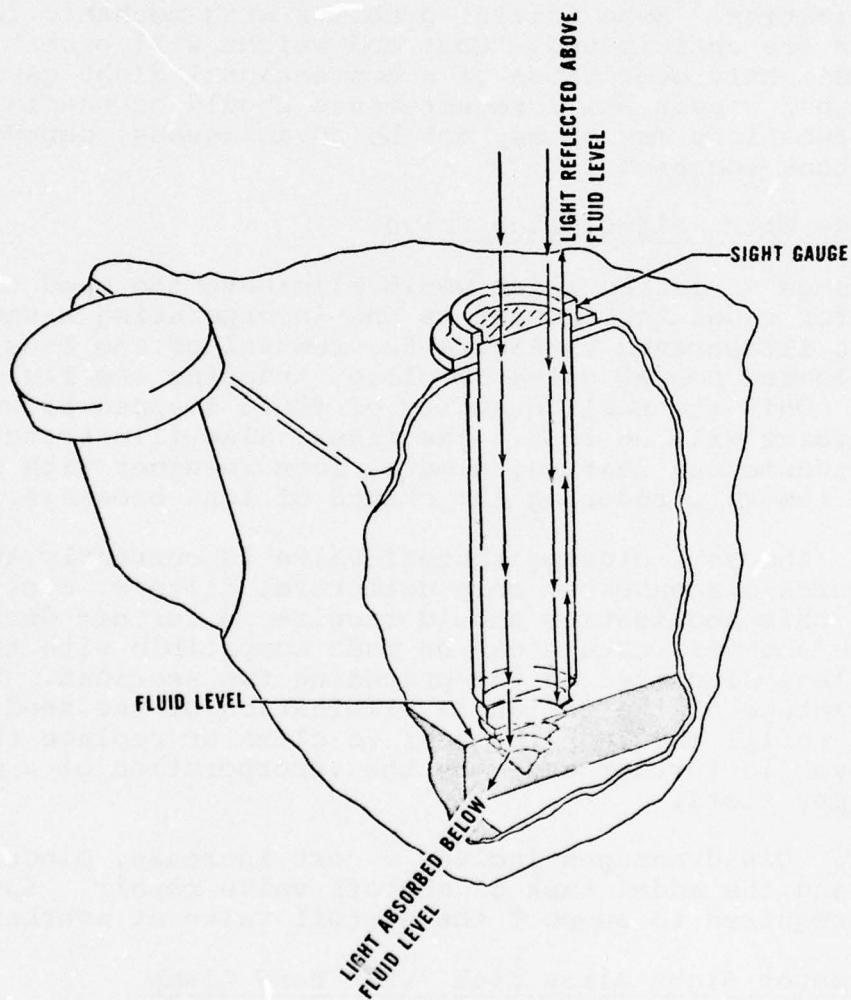

Figure 51. Top-viewing sight gauge with high-contrast fresnel lens.

into the conical end, producing a high contrast oil level indication which appears as a darkened circle in a bright background. An over-full indication is completely dark, while an empty indication is completely bright. Other variations in image are feasible.

Benefits. In addition to those discussed in the preceding section, the top viewing gauge eliminates the need to drain and refill the tank in order to replace the gauge. Also, the top viewing gauge is, in effect, a remote indicator that may be placed close to the filler port on large transmissions, thereby converting a two-man servicing operation into a one-man job.

Penalties. The gauge lacks the ability to convey the color of the oil and produces an image which differs from the usual level indication. Some initial problems with mechanic familiarization are anticipated. Cost and weight will probably increase slightly over those of a conventional sight gauge, but logistics and repair skill requirements should be unaffected. Tank top locations may or may not be advantageous, depending upon the tank location.

#### Sight Gauge With Self-Closing Valve

Another gauge variation which would eliminate the need to drain the tank for gauge replacement is one incorporating a shut-off valve. As illustrated in Figure 52, removal of the lens allows a spring-loaded poppet valve to close, trapping the fluid in the tank. Only the small quantity of fluid trapped between the lens and valve will be lost. The figure also illustrates another recommended feature, a metal lens retainer with slots to assist removal, reducing the chance of lens breakage.

Benefits. The self-closing shutoff valve is currently available in quick-disconnects, chip detectors, filters, etc. Adaptation to this application should require no further development. The shutoff feature can be made compatible with the high contrast lens discussed in the preceding two sections. The major advantage of the design is elimination of the need to drain and refill the tank in order to clean or replace the lens. Lens removal is further eased by the incorporation of a metal rim with pry slots.

Penalties. Disadvantages include a cost increase, minor weight increase and the added task of shutoff valve repair. Spare parts would be required to support the shutoff valve at overhaul.

#### Large-Diameter Sight Glass With "VEE" Band Clamp

Replacement of large sight glasses is facilitated with a concept incorporating a single "vee" band clamp, in lieu of attaching

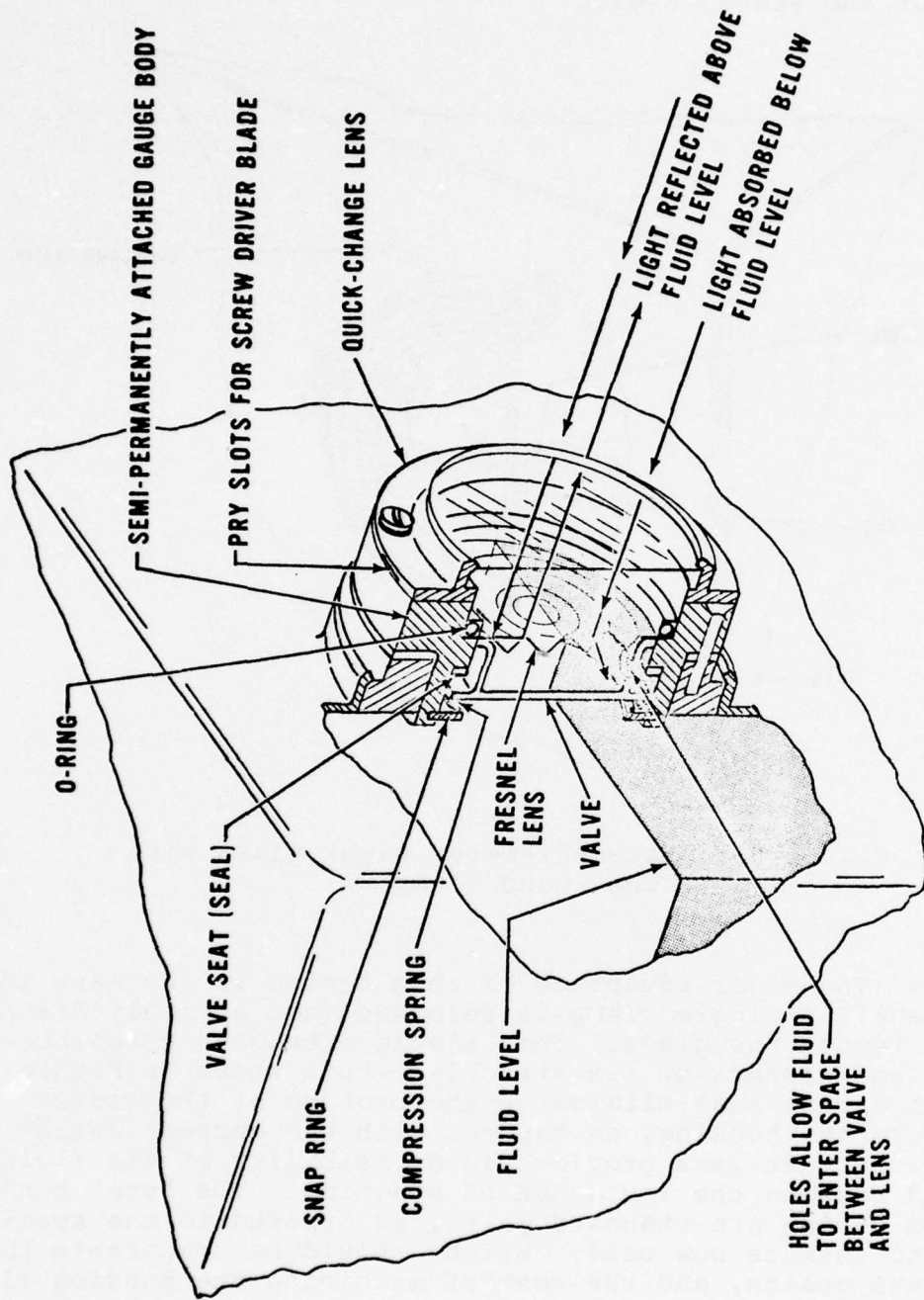

Figure 52. Sight gauge with self-closing valve.

studs and nuts. Shown in Figure 53, the design has a circular window employing a high-contrast fresnel lens to eliminate the need for a separate reflector. An O-ring is used in lieu of a gasket for the static seal.

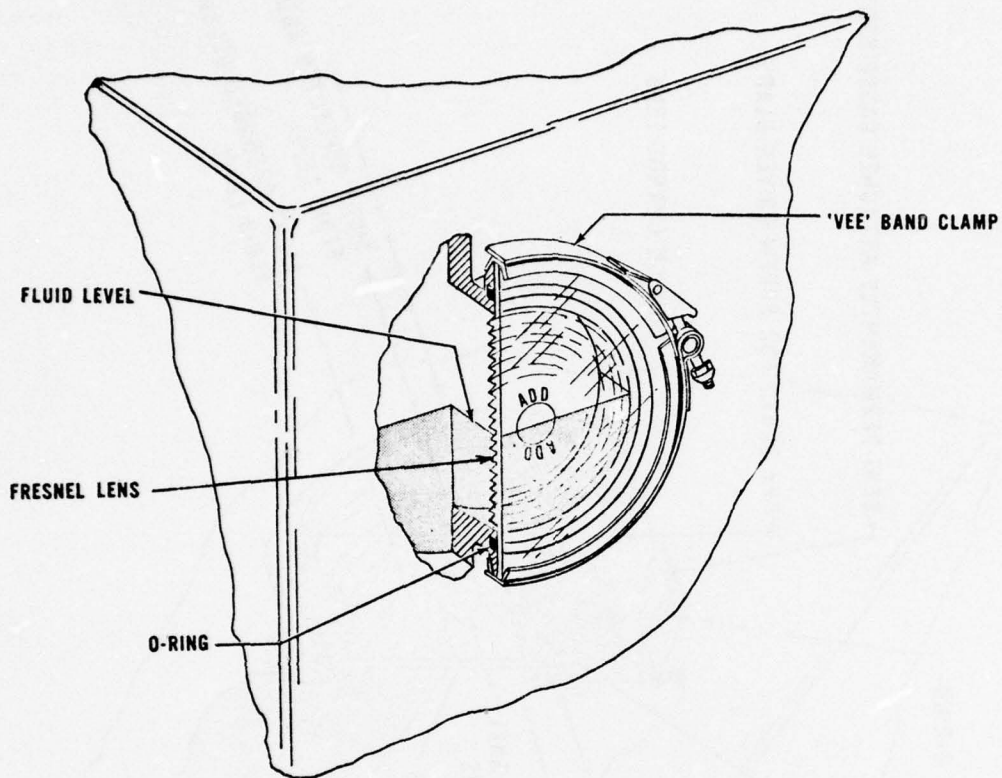

Figure 53. Large-diameter sight glass with "Vee" band clamp.

Benefits. The major advantage of this design is its ease of replacement. A single clamp is released (not entirely dismantled) to remove the glass. This simple arrangement replaces the nuts and washers on six attaching studs shown in Figure 48. Use of an O-ring seal eliminates the problem of the gasket adhering to the housing, as happens with the current design. The high-contrast lens provides good visibility of the fluid level and reduces the incidence of staining. The "vee" band clamp and O-ring are standard parts, as opposed to the special frames and gaskets now used. Weight should be comparable to the current design, and the cost of machining the housing flange and O-ring groove will probably be no greater than the cost of machining the studs presently used.

Penalties. The problem of having to drain fluid from the reservoir to replace the sight glass is not eliminated.

#### Sight Gauge With Segregated Indicating Fluid

Discoloration of the glass in conventional sight gauges, caused by oil staining, is eliminated with a concept which segregates the indicating fluid from the lubricating fluid. As shown in the sketch of Figure 54, a flexible diaphragm separates the

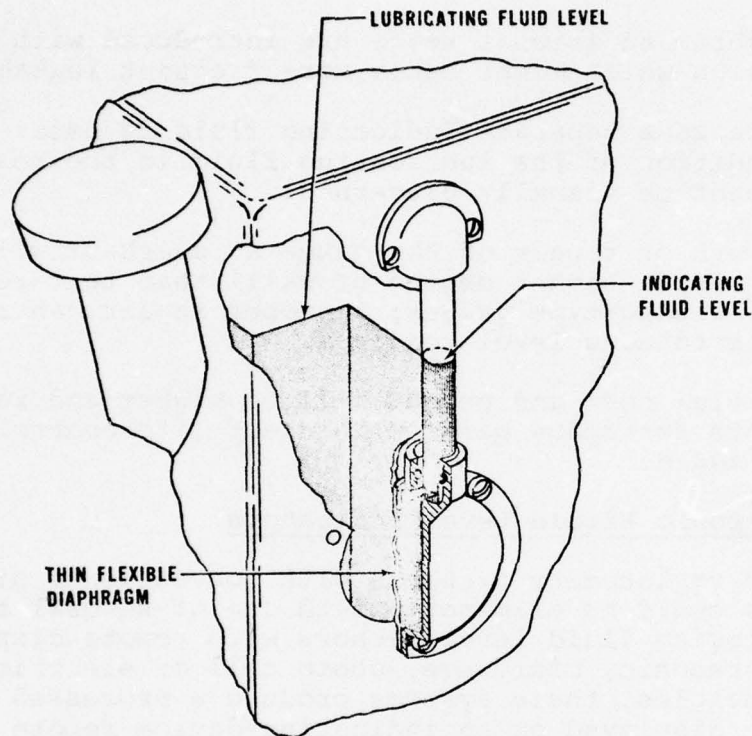

Figure 54. Sight gauge with segregated indicating fluid.

indicator from the reservoir, allowing the use of a highly visible, nonstaining fluid in the indicator. Removal of the gauge for cleaning should be virtually eliminated. If need be, however, the transparent tube may be replaced without draining the fluid in the reservoir by leaving the oil segregating diaphragm attached to the reservoir.

Benefits. The main advantage offered by this type of gauge, as set out in the original objective, is freedom from the need for periodic internal cleaning. Gauge reading should be more

reliable in poor light because of the opaque fluid used in the indicator. An added advantage is that the fluid in the reservoir will not be lost in the event that the sight tube is broken.

Penalties. The segregated fluid gauge has several disadvantages:

1. The sight tube, being located on the exterior of the reservoir, should be more vulnerable to damage.
2. Several additional seals are introduced with this design which might cause more frequent leakage.
3. Because a separate indicating fluid is used, the condition of the lubricating fluid in the reservoir cannot be visually discerned.
4. Rework or repair of the gauge at overhaul will require a higher degree of skill than that required for window-type gauges; improper repair can result in erroneous level readings.
5. Initial cost and weight will be higher and requirements for spare parts with shelf life control will be added.

#### Remote Electronic Liquid Level Indicators

Cleaning and replacement problems with conventional oil level sight gauges could be eliminated with one of several types of systems employing fluid level sensors with remote displays. Based on ultrasonic, microwave, photo cell or electrical capacitance principles, these systems produce a processed signal which can be displayed on an indicating device remote from the sensor.

Ultrasonic and microwave systems depend on probes which emit low energy waves, beamed towards the fluid surface and partially reflected back to the probe. Figure 55 illustrates, schematically, a typical ultrasonic system. The nature of the reflected beam is altered in accordance with the distance between the probe and the liquid surface. By processing the return signal, a display device (such as a meter) can be made to indicate fluid level.

Capacitance sensors operate on the principle of change in electrical capacitance which occurs between two charged plates as the fluid separating the plates is altered. The change in capacitance between partially immersed plates is dependent on fluid

level. This capacitance change can be converted to a signal for display on an indicator.

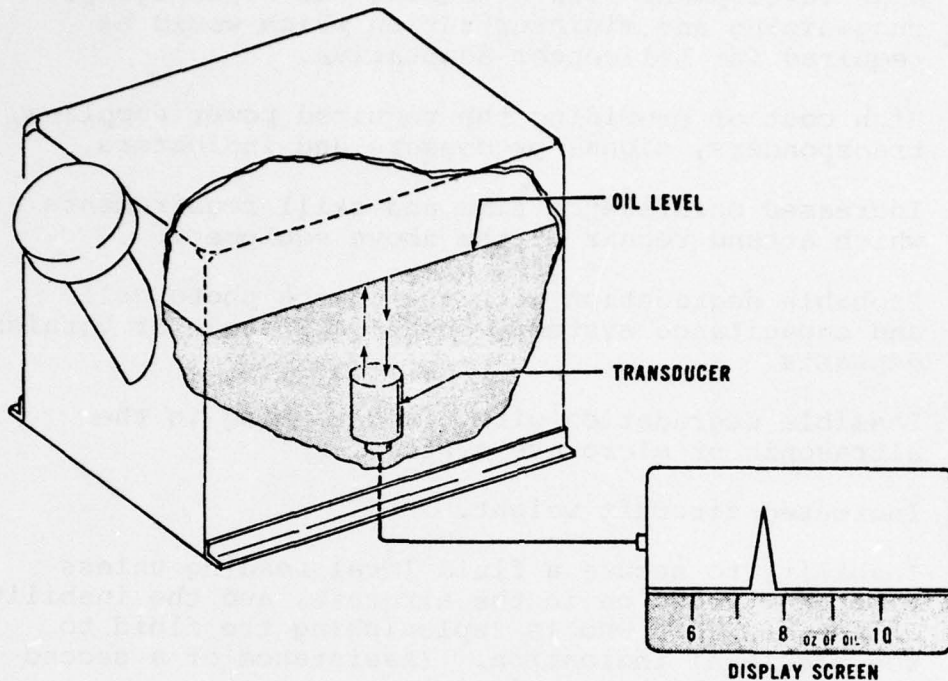

Figure 55. Ultrasonic liquid level indicator.

Photo cell systems rely on the changed reflection of a light beam from a prismatic surface, depending on its degree of immersion in a liquid. An immersed prism reflects a light beam, while a prism in air does not. By using a number of prisms at different levels, it is possible to discern the fluid level relative to the array of prisms, with a matching array of photo cells.

**Benefits.** It is possible that any of these systems could be adapted successfully to helicopter fluid reservoir systems. Their major advantage, aside from eliminating some of the maintenance problems with conventional oil level sight glasses, is that of providing a cockpit display of oil level, accessible both in flight and on the ground, and a more accurate measure of fluid level. They also lend themselves to integration with diagnostic processing equipment.

**Penalties.** The electronic remote sensing systems all suffer a number of significant disadvantages brought about by their

inherently greater sophistication and complexity. These include:

1. High development risk attending the repackaging, ruggedizing and miniaturization which would be required for helicopter adaptation.
2. High cost of providing the required power supplies, transponders, signal processors and indicators.
3. Increased maintenance time and skill requirements which attend repair of the above equipment.
4. Probable degradation with use in the photo cell and capacitance systems, due to oil stain or varnish deposits.
5. Possible degradation with fluid foaming in the ultrasonic or microwave systems.
6. Increased aircraft weight.
7. Inability to secure a fluid level reading unless power is turned on in the aircraft, and the inability of the mechanic who is replenishing the fluid to see the level indication. (Assistance of a second mechanic would be required.)
8. Inability to observe fluid color.

Overall, the substantial disadvantages of these systems could not justify their adoption on the basis of reducing maintenance time alone.

#### Remote Mechanical Liquid Level Indicator

Another type of remote fluid level indicator uses a float to sense fluid level in the tank. As shown in Figure 56, the float is connected to a position detecting device, either directly, through a linkage, or through a gear train. The position detector could be a direct reading dial indicator, or in the case illustrated, an electrical position indicating device. The electrical output from the position sensor may be used to actuate a cockpit display.

In the device illustrated, motion of the float causes rotation of the spiral ribbon cam. The cam rotation is transmitted through a gear train to a rotary variable differential transformer, which is a very low friction rotary position sensor. Output voltage of this device varies in proportion to its angular position.

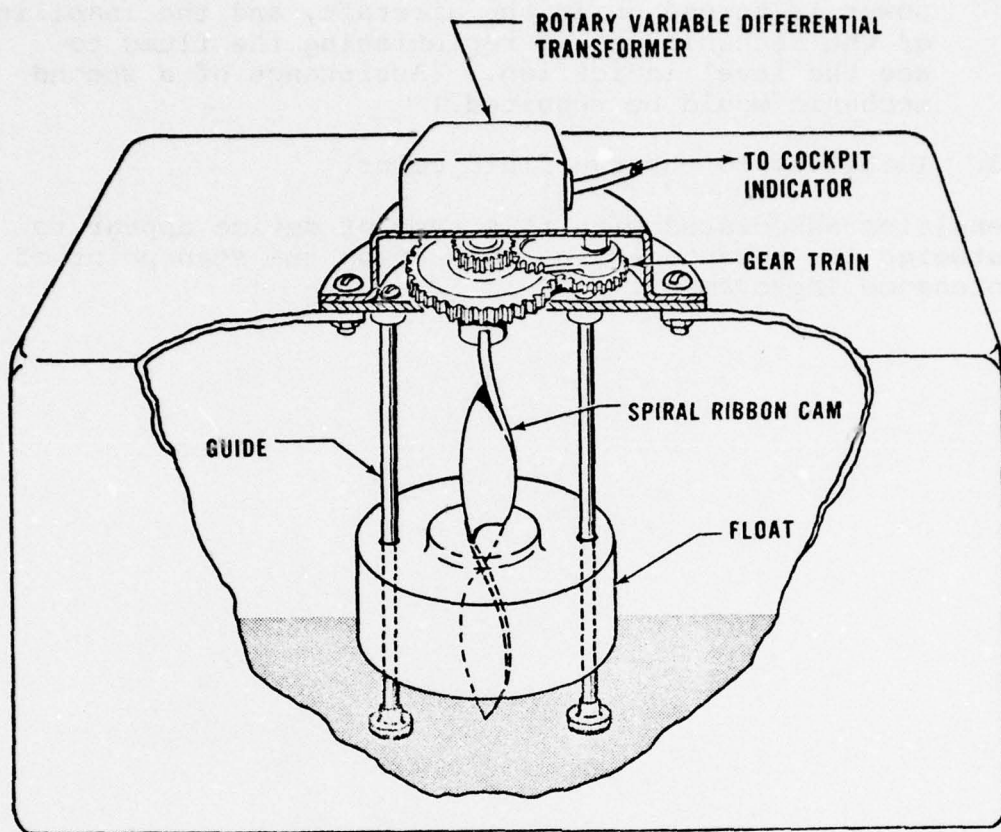

Figure 56. Remote mechanical fluid level indicator.

**Benefits.** Devices of this type, based on proven operating principles, already exist. Development risk, therefore, is negligible. The principal advantage of these devices is their cockpit display of the oil level, which is accessible both in flight and on the ground. They avoid the frequent lens cleaning and replacement problems typical of conventional sight gauges and are adaptable to diagnostic processing equipment.

**Penalties.** The remote mechanical liquid level indicator suffers most of the significant disadvantages mentioned for the electronic types, including much greater cost and complexity and added aircraft weight. Other disadvantages include:

1. Increased maintenance time and skill requirements.

2. Inability to secure a fluid level reading unless power is turned on in the aircraft, and the inability of the mechanic who is replenishing the fluid to see the level indication. (Assistance of a second mechanic would be required.)
3. Inability to observe fluid color.

The penalties associated with this type of device appear to far outweigh its advantages, at least from the standpoint of a maintenance improvement.

## SURVEY RESULTS AND DESIGN STUDY

### RUBBER BOOTS

Push-pull hydraulic actuators widely used in aircraft control systems have precisely machined, plated rods which extend outside the fluid cylinder through a packing or fluid seal. To prevent wear on the seal and subsequent leakage past it, the rod must be maintained free of corrosion and scratches. This requires the exclusion of contaminants. Protection is normally provided by the installation of an elastomeric tube or "boot". The boot is molded in one piece over a convoluted mandrel to provide the necessary flexibility to accommodate the axial motion of the rod. The boot is slipped over the rod with one end secured to the actuator housing and the other end to the output (movable) end of the rod with band clamps. Boots of this type are made in a wide variety of widths and lengths, and most are custom molded.

### REPAIR TIME DATA AND FIELD-REPORTED PROBLEMS

Rubber boots on the UH-1/AH-1 hydraulic actuators and the CH-54 main rotor pitch links are replaced with sufficient frequency that they contribute significantly to the overall repair rates of their respective end assemblies. Through continual cycling during operation and through exposure to weather and contaminants, rubber boots, such as these, deteriorate, crack and tear. The time to effect replacement of boots in the noted applications averages from approximately 1.5 to 2.5 man-hours, as indicated in Table 18. The time is expended mainly on disconnecting and reconnecting the rod or linkage over which the boot is installed. Only two problems, both related to boots on the UH-1 actuators, were specifically mentioned by people in the field.

#### Boot Clamps (UH-1)

The clamps securing the rubber boots on the UH-1 hydraulic actuator bottom out (cannot be completely tightened) before the boot is secured (Figure 57). This appears to be a tolerance problem with the clamp and/or wall thickness of the boot. Use of a standard clamp which can accommodate a range of diameters, rather than one specific diameter, could eliminate the problem. A second problem with the clamp, related to the first, is that the Phillips-head screw used to tighten the clamp strips easily (Figure 58). At a small weight penalty, external wrenching screws could be used to eliminate the stripping problem.

TABLE 18. REPAIR TIME DATA, RUBBER BOOTS

Model	Component/Part		Elements of Replacement Task				
			Total Task Time	Dis-assy. and Assy.	Adjst, Align, Etc.	Drain, Lube, Service	In-spect and Test
UH-1/ AH-1	Hydraulic Actuator (Upper Boot)	Hrs.	1.6	1.5			0.1
		Pct.		93.8			6.3
UH-1/ AH-1	Hydraulic Actuator (Lower Boot)	Hrs.	1.6	1.5			0.1
		Pct.		93.8			6.3
CH-54	Main Rotor Head (Pitch Change Link Boot)	Hrs.	2.6	1.0			1.6
		Pct.		38.5			61.5
Weighted Average		Hrs.	2.1	1.2			0.9
		Pct.		57.1			42.9

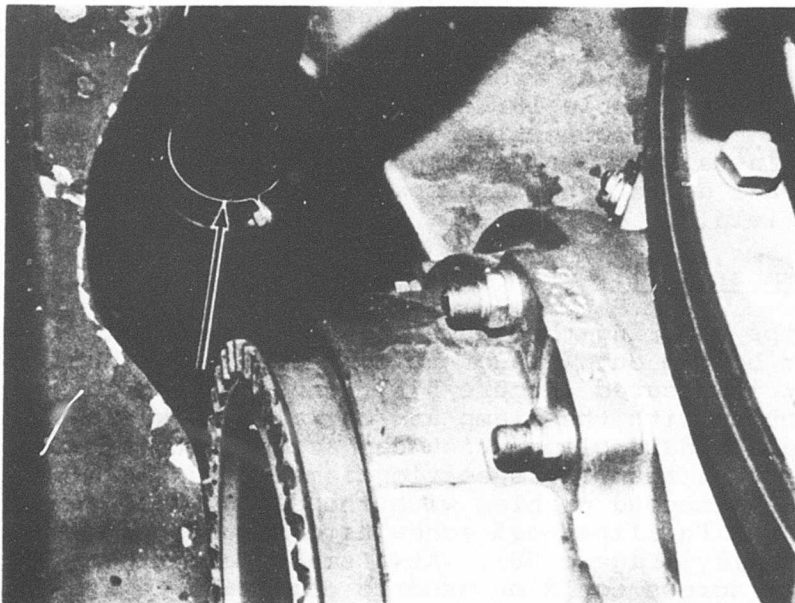

Figure 57. "Bottomed-out" boot clamp, UH-1 hydraulic actuator.

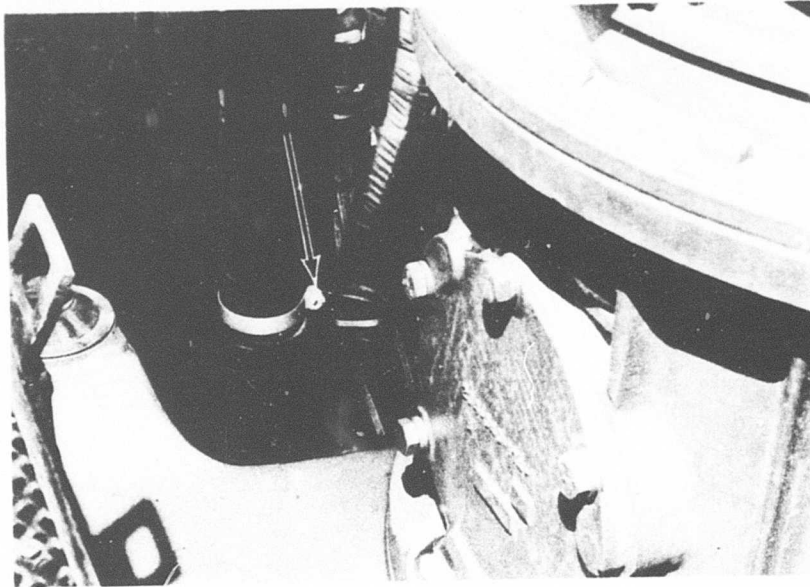

Figure 58. Stripped Phillips head screw, UH-1 hydraulic actuator.

#### DESIGN STUDIES

Three rubber boot design concepts were studied, all with the objective of avoiding the need to disconnect hardware (control rod, piston rod, etc.) to remove and install boots. All were successful in this aim, but only with the introduction of significant penalties. Generally, the proposed designs will be more costly and less reliable than the conventional, one-piece, molded rubber boot. There may be little (or no) maintenance time saving with any of the three design concepts, because of the more involved installation techniques they entail. Considerable development would be needed to determine whether satisfactory designs, suitable to field maintenance, are possible.

#### Boot With Longitudinal Split Through Convolution

This type of boot, shown in Figure 59, is used commercially in special applications, such as dirt excluders for large lead screws, hydraulic cylinder piston rods and guide columns for movable machine parts, where the downtime and labor cost to disassemble the machine to replace a one-piece boot would be excessive.

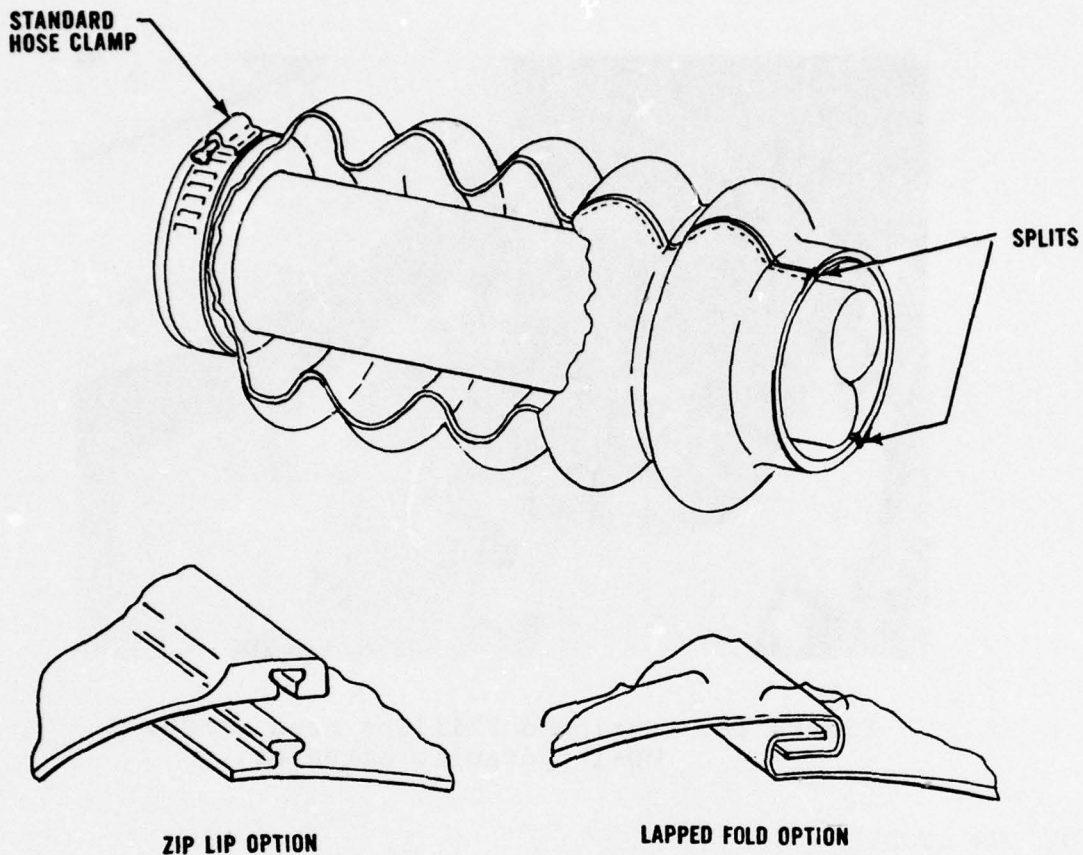

Figure 59. Boot with longitudinal split through convolutions.

In one configuration, a longitudinal cut, parallel to the centerline, is made the length of the boot. The boots are made of relatively thin plastic sheet stock. Individual discs are die-cut from the sheet stock and are electronically welded together at the outside and inside diameter to form as many convolutions as necessary. After installation, the longitudinal joint is secured with pressure-sensitive tape.

In another configuration, the one shown in Figure 59, a boot, molded from elastomeric material, would be assembled around the control rod, shaft, etc., as two identical halves with parallel, longitudinal split lines. The convolutions and folded lap seams would be molded in as shown. The folded lap would be designed to form a mechanical closure in preference to use of adhesive sealing, although both or a combination of methods could be used.

The crux of the second design will be the treatment of the joint since it must approximate the stiffness and fatigue endurance of the basic molded convolution configuration as closely as possible. An alternate to the "lapped fold" seam could be the Zip-Lip or Mini-Grip toothless "zipper" closures used on plastic bags. Velcro hook and looped pile strips could be used on large size boots where tight fluid sealing is not critical. In the event that the ratio between the stiffness of the seam and the nonseamed convoluted area is too great, so as to produce excessive column instability, a false seam (localized stiffening strip) could be added midway between and parallel to the side seams to provide symmetry.

Benefits. The primary advantage of the design, from a maintenance viewpoint, is avoidance of the need to disconnect hardware to remove and install the boot. The configuration employing pressure-sensitive tape would fit a wide range of extensions, since it will compress to a relatively small solid length and will extend to five to seven times its compressed length.

Cost should be comparable to a one-piece molded boot, unless special sizes are required, which would involve some added tooling (die) costs. For a given boot configuration, especially where a relatively thin gauge material will suffice, a boot of the first design made of polyvinylchloride or polyurethane film will be lighter than a comparable molded elastomeric boot. However, where higher strength is required, the one-piece molded boot can be made from thicker and stronger materials. Reliability should be equal to an elastomeric boot in comparable gauges. Shelf life should also be equivalent for temperatures in the normal ambient range.

Penalties. The split boot is more complex by virtue of the seam and associated closure. The material thickness may not provide sufficient strength for many aircraft applications, especially since the joint will be weaker than the basic material and could open under extreme distortion. Also, since the Zip-Lip type of closure increases the thickness of the boot locally, a boot of this type will have fewer convolutions per unit length and, consequently, a greater compressed height than for a comparable one-piece molded boot.

The boot may not be as durable where physical exposure indicates a need for high puncture and tear resistance and may not be usable at as low a temperature range. Limitation to lighter gauges could also restrict use where windstream impingement is a factor.

The pressure-sensitive tape, if used to make the longitudinal closure, will have a lower allowable tensile strength, in the

adhesive bond, than that of basic boot material. The adhesive may creep if subjected to high temperatures and certain solvents. These problems can be minimized by selecting materials best suited for the exposure of a particular application.

Clearer and less encumbered access would be needed for the installation and removal of a split boot than for a one-piece boot. This is because the mechanic must be able to touch the boot along its complete length, rather than just at the ends in order to open or secure the longitudinal closure.

#### Wrap-Around, Preformed Tape Boot

In the final form, this basically would be a tape made of elastomer, or an elastomeric-coated fabric, such as Dacron, at least two convolutions in width, with the convolutions running lengthwise of the tape. Figure 60 shows the concept. The

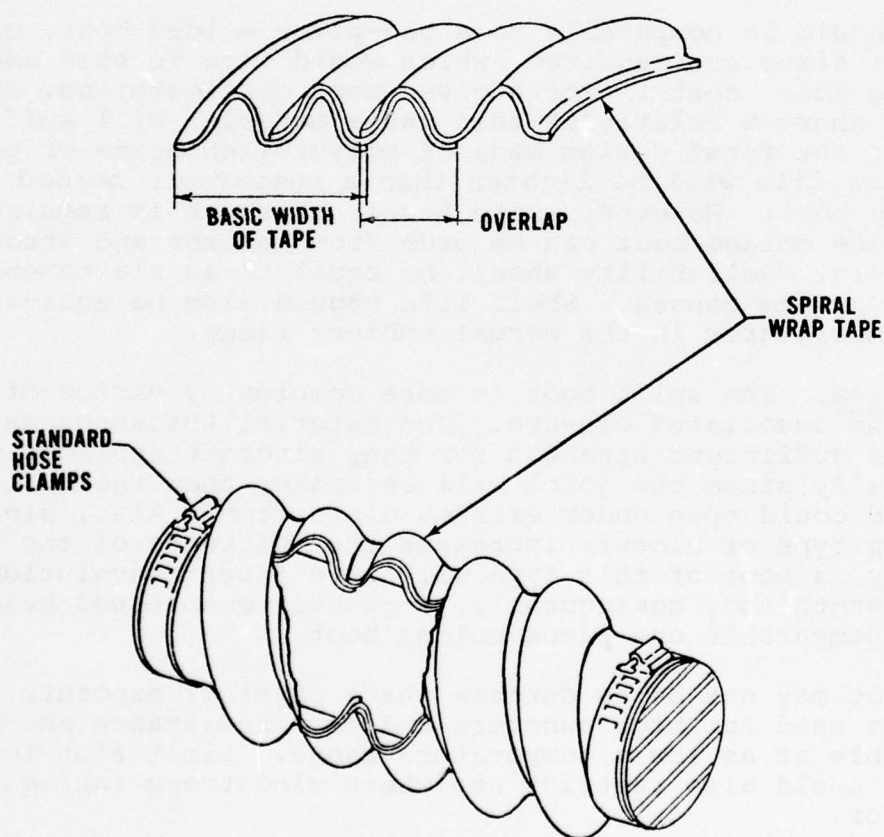

Figure 60. Wrap-around, preformed tape boot.

inside and outside diameter of the convolutions and their pitch would be a function of the particular application. For shipping and storage, the tape would be wound around a mailing tube of about the same inside diameter as the spiral mandrel about which the tape was formed initially.

For installation, one end would be held by a band clamp, while the tape is wound about the item to be protected (piston rod, etc.) with a one convolution pitch overlap as shown in the sketch. The closing end would be cut at an angle and clamped in place.

Design criteria would have to be developed to determine the relationship of the critical dimensions, such as limits and ratios of inside and outside diameter, width, spiral angle, convolution amplitude and pitch, amount of overlap, torsional wrap-up and material flexibility. There will be a need to determine how well a spiral configuration can extend and compress within a symmetrical envelope. The column stability may be inadequate for more than limited excursions. A tape would have to be preformed for each application, except where length is the only variable. The spiral angle must be kept small to provide maximum wrap-around for ease of clamping at each end fitting. Also, a small spiral angle will be the closest approximation to a normally convoluted boot with zero lead angle.

If the tape were to be extruded or molded in the full, convoluted form and in a straight, continuous section, it would not retain the same shape when wrapped around something, since the inner and outer edges of the convolutions would form about different radii. The tape must be extruded or formed from strip stock into the convoluted configuration and wrapped into the final spiral shape simultaneously. It must be packaged in the same configuration.

Of primary concern is the need to effect a fluid-proof seal along the edges of the tape overlap. One scheme is to supply the boot with a precoated, semicured or uncured band of adhesive. If in a semicured state, the adhesive could be activated by solvent or heat after being wound in place. If uncured, the tape would be supplied with a pull-off protector strip, which would be removed just prior to application. Overwrapping the spiral with a pressure-sensitive, stretchable, plastic tape is another possible closure method.

Benefits. This concept also eliminates the need to disconnect hardware to remove and install the boot. Cost should be comparable to that of a molded boot.

Penalties. The preformed tape design suggests most of the disadvantages noted for the boot with longitudinal split through convolutions. It will be slightly heavier due to the overlap of the convolutions. Reliability may be lower if only the frictional contact along the overlapping edge is available. In that situation, the fluid-tightness of the boot will be less. Access must be sufficient to wrap the tape around the article to be protected. An adhesive system could undoubtedly be developed; however, there are doubts as to whether a simple, straightforward and reliably repetitive technique, suitable to field maintenance, can be found.

#### Snap Segment Boot

In this concept, shown in Figure 61, the boot is assembled in place from a series of discs, which are individually deflected to open at the radial seam while being slipped over the piston rod, control rod, etc. Each disc is then squeezed at its periphery so as to overlap at the radial seam and temporarily reduce the outside diameter while the disc is slipped into place under the outer U-shaped edge or fold of the mating disc. When released, it springs outward to become trapped in the outer fold. The seam fold at A-A is hooked at the same time. The process is repeated for each subsequent disc. Note that the next disc would be an "opposite" disc; that is, there are two disc shapes, one with an inside diameter V-shaped edge and one with an outside diameter U-shaped edge. The radial seams of each disc would be continually displaced azimuthally so as to achieve a reasonably uniform distribution of the stiffness which results from the seam discontinuity.

Benefits. This concept also satisfies the objective of not having to disconnect hardware to install or remove a boot.

Penalties. Major penalties are suggested by this design. Although the need to disconnect hardware is eliminated, there probably would be little time saving (if any) because of the more involved assembly procedure. Its cost will be highest of the several concepts considered because of the fabrication, tooling, precision and quality control required. It may possibly be lighter than a molded, one-piece boot, but will be heavier than the taped seam boot for a given configuration. From a reliability standpoint, the design may be troublesome because the interlocking joints are held together by spring tension and have a potential for fretting, particularly if made of metal.

Although a fair degree of sealing against dust and dirt seems capable of achievement, the ability to obtain a fluid tight seal at the disc joints is questionable unless a sealant can be applied to the contact interfaces to act as a gasket. It

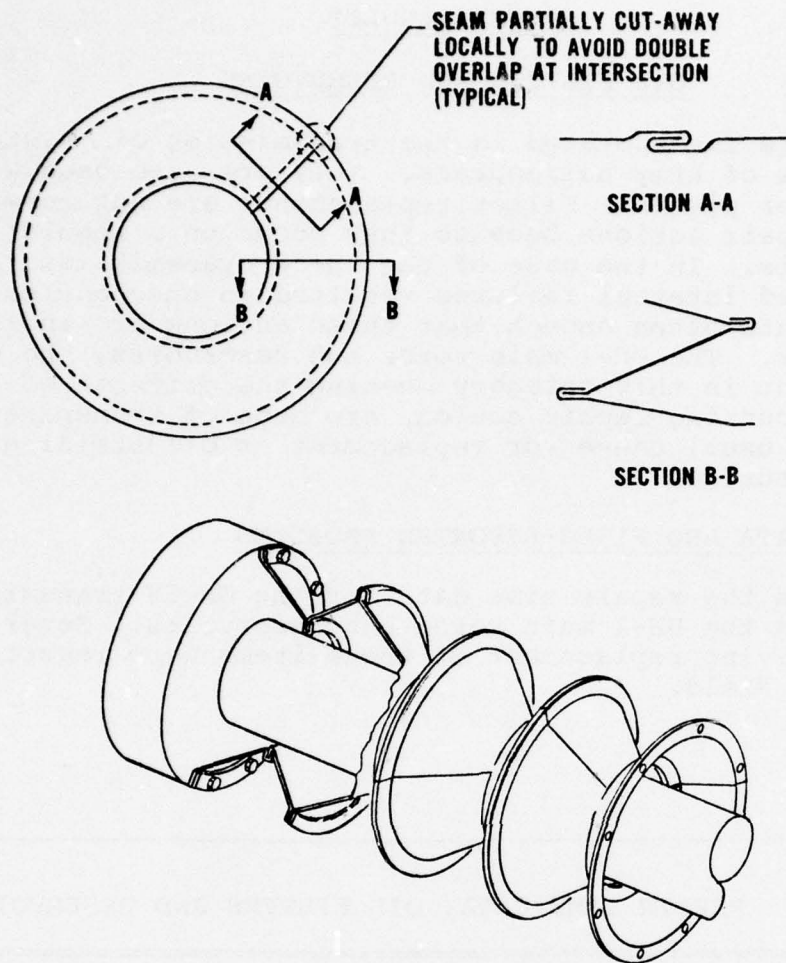

Figure 61. Snap segment boot.

will probably be necessary to fabricate some trial discs to permit adequate evaluation of the mechanic's assembly techniques and the practicality of making an installation without any special tools. Conceivably, a plier-type tool would greatly facilitate handling the discs, particularly to compress them. Considerable access space will also be required. Overall, the penalties involved with this concept appear to greatly outweigh its benefits.

## SURVEY RESULTS

### OIL FILTERS AND RESERVOIRS

Oil filters are incorporated in the transmission oil systems of all six models of Army helicopters. They are also used with auxiliary power plants. Filter replacements are not normally considered repair actions because they occur on a regularly scheduled basis. In the case of the OH-58 transmission, however, suspected internal failures resulted in unscheduled filter replacements often enough that these actions are included in this report. The UH-1 main rotor hub reservoirs, the only other component in this category meeting the criteria of a significantly occurring repair action, are made of transparent plastic. The usual cause for replacement is oil staining on the interior surface.

#### REPAIR TIME DATA AND FIELD-REPORTED PROBLEMS

Table 19 lists the repair time data for the OH-58 transmission oil filter and the UH-1 main rotor hub reservoirs. Several problems involving replacement of these items were reported by people in the field.

TABLE 19. REPAIR TIME DATA, OIL FILTERS AND RESERVOIRS							
Model	Component/Part		Elements of Replacement Task				
			Total Task Time	Dis-assy. and Assy.	Adjst. Align, Etc.	Drain Lube Ser-vice	In-spect and Test
OH-58	Main Transmission (Oil Filter)	Hrs.	2.1	1.7		0.2	0.2
		Pct.		81.0		9.5	9.5
UH-1	Main Rotor Hub (Trunnion Reservoir)	Hrs.	0.6	0.4		0.1	0.1
		Pct.		66.7		16.7	16.7
UH-1	Main Rotor Hub (Grip Reservoir)	Hrs.	0.8	0.5		0.2	0.1
		Pct.		62.5		25.0	12.5
Weighted Average		Hrs.	0.8	0.6		0.1	0.1
		Pct.		75.0		12.5	12.5

#### Access Problems (OH-6, CH-47)

Access to the oil filter in the OH-6 transmission is obtained through the aft cabin and involves removal of the sound proofing, the access covers and the transmission drain assembly. The oil filter might have been located remotely for better access, but the added weight of lines and fittings might not be justified.

Access to the oil filters in the forward and aft transmissions of the CH-47 is limited due to the proximity of the structure and safety wiring is particularly difficult. The safetying problem might have been eased through the use of self-locking nuts on the attachment studs.

#### Bonding Problem (CH-54)

Oil reservoirs in the CH-54 main rotor head are bonded in place. As with other assembly procedures involving adhesives, there are problems involved with cleaning off old adhesive and then delaying completion of the repair while the newly applied adhesive cures. In this case, the bonding operation might have been eliminated by using a gasket, a retaining ring and a circular pattern of cap screws to secure the reservoir. Weight and cost would increase, however.

SURVEY RESULTS

MECHANICAL STOPS AND PADS

Mechanical stops and pads generally are not among the more frequently replaced items. However, three such items did make the list of significantly occurring repair actions: the OH-6 main rotor lead-lag stops, the AH-1 main rotor buffer pads, and the CH-54 tail rotor pitch link rubber bumpers. The first two items are bonded in place, the latter is part of a bolted stackup. In each case, there are eight items per head assembly.

REPAIR TIME DATA AND FIELD-REPORTED PROBLEMS

Table 20 provides repair time data for the described items. All are replaced individually, except the AH-1 buffer pads which are replaced in sets of eight. This accounts for the long replacement time given. Also, the AH-1 action is the only one listed that is accomplished off-aircraft. Field personnel reported problems with two of the three items, both of them installed by bonding.

TABLE 20. REPAIR TIME DATA, MECHANICAL STOPS AND PADS							
Model	Component/Part		Elements of Replacement Task				Component Repl. Time *
			Total Task Time	Dis-assy. and Assy.	Adjst. Align, Etc.	Drain, Lube, Ser-vice	
OH-6	Main Rotor Hub (Lead-Lag Stop)	Hrs. Pct.	0.8 87.5	0.7		0.1 12.5	
AH-1	Main Rotor Hub (Buffer Pads)	Hrs. Pct.	6.5 76.9	5.0 21.5	1.4	0.1 1.5	6.9
CH-54	Tail Rotor Head (Rubber Bumpers)	Hrs. Pct.	1.1 27.3	0.3		0.8 72.7	
	Weighted Average	Hrs. Pct.	1.0 60.0	0.6 0.0	0.0	0.4 40.0	

\* Off-aircraft tasks.

Problems With Adhesives (OH-6, UH-1)

The lead-lag blade stops on the OH-6 main rotor hub are bonded in place (Figure 62). Old adhesive residue must be scraped off and, if the scraper penetrates the paint and chemical surface film, the surface finish must be restored. Cure time of the adhesive is 8 hours. This task might have been eliminated if the stops were secured to the hub with machine screws. Some weight penalty would probably be incurred, however, because of the hub reinforcement needed to counteract the introduction of the notch effects.

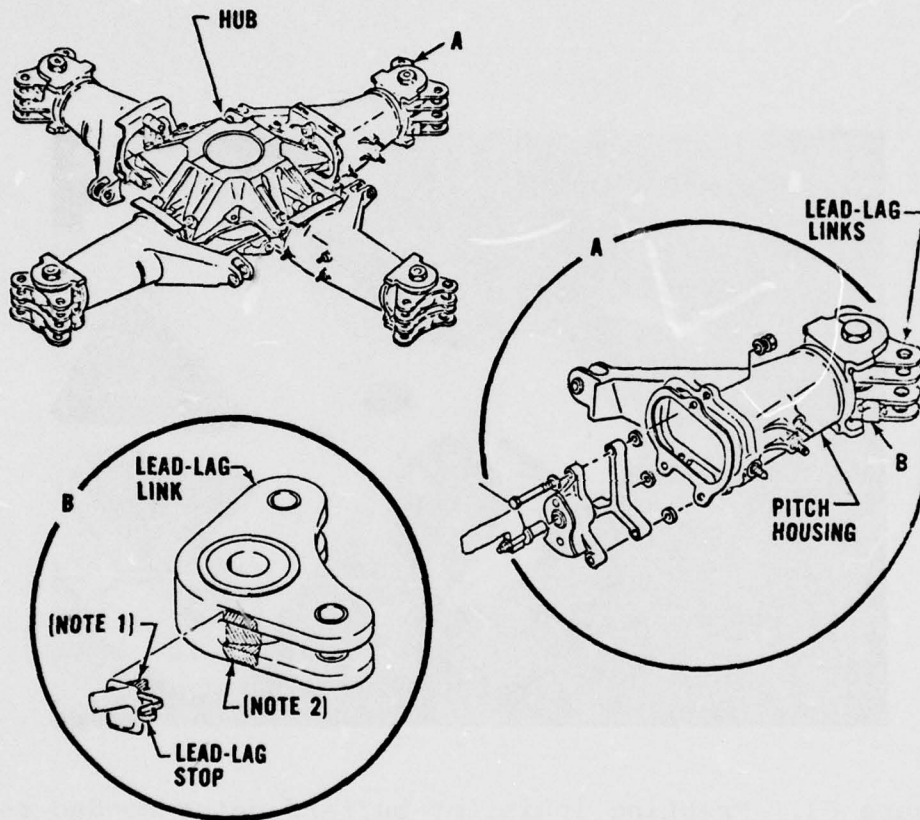

**NOTES:**

1. FOR STOP REMOVAL, PLACE WOOD DOWEL HERE.  
STRIKE SHARPLY WITH HAMMER TO BREAK STOP BOND.
2. BOND ALL STOP-TO-LINK SHADED CONTACT SURFACES  
WITH ADHESIVE.

Figure 62. Bonding lead-lag stop, OH-6 main rotor hub.

The buffer pads on the AH-1 main rotor hub are bonded in place. Repair time is consumed during the removal of the old adhesive residue, and cure time after replacing the pads is 12 hours at room temperature (Figure 63). The bonding task might have been simplified if the buffer pads were supplied with pressure-sensitive adhesive.

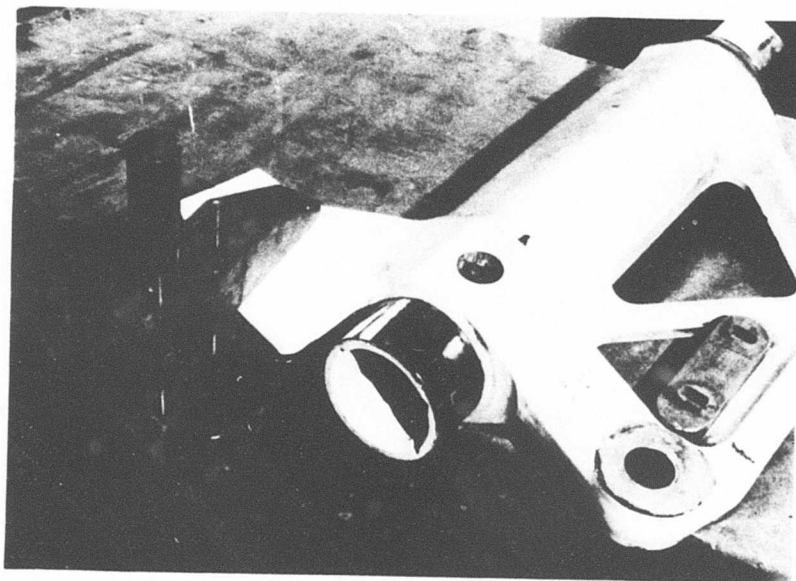

Figure 63. Fretting inhibitor buffers being bonded to extension, top view, AH-1 main rotor hub.

## CONCLUSIONS

The objective of this study was to analyze and identify the factors responsible for the high man-hour cost of repairing selected helicopter components and to develop design solutions that will improve the repairability of these components in future aircraft. The study considered improved applications of current design practice and the development of new engineering concepts. Conclusions are made in three areas.

### Survey Methods

Field interview techniques are an effective method of obtaining data on aircraft maintenance problems. The relatively modest survey conducted for this program (12 days in the field) produced statistical data and commentaries on component repair that could not be obtained via any of the standard data collection systems operated by the Army. (The systems simply do not provide data this specific.) It was shown that properly structured interviews are able to solicit reasonable estimates of such quantitative factors as maintenance frequency and man-hours and that cross correlation is useful in smoothing out variations between respondents. Personnel in the field do have difficulty recognizing hardware design deficiencies related to maintenance, however, and an experienced interviewer is needed to draw them out.

### Survey Results

A number of conclusions were reached concerning the scope of major component repairs in the field and their man-hour cost to the Army:

1. Extensive repair of major mechanical components is not being done in the field, even at General Support level.
2. The repairs that are being made involve, usually, very limited component disassembly and the replacement of relatively simple parts, primarily seals.
3. Lip seals in rotor heads and gearboxes are, by far, the largest single contributor to repair time. Seals of all types represent approximately three-fourths of the repair man-hours expended.

4. On a fleet-wide basis, the estimated direct labor cost of repair, as assessed by the study, is in the order of 1/4 man-hour per flight-hour. Considering the components for which no data was collected and the repair actions not included for failing to meet the criteria of significantly occurring, this is a conservatively low estimate. The total cost to the Army, when indirect labor and unproductive time is included, could easily exceed 1/2 man-hour per flight-hour.
5. There exists, in some cases, considerable variation between the types of repairs authorized by official Army publications and those actually being performed in the field. Local policies and practices were found to be one of the significant factors affecting the scope of repair performed.

#### Design Studies

Major component repair, as brought out by this study, involves mainly the replacement of simple, relatively accessible parts, primarily seals. The man-hour cost of these repairs was found to be related as much to the poor reliability of some of these parts as it is to problems associated with their repair. The simplicity of the parts, and their installation, makes it difficult, in many cases, to conceive of ways of improving significantly upon the design from the standpoint of repairability, at least in ways that are economically realistic. Where the prospects for improving repairability are slight, the most straightforward approach to reducing maintenance costs is to improve upon reliability, although this, admittedly, has been the focus of most of the prior work in this area.

The specific objective of the design studies was to develop concepts and principles for improving the repairability of major components. But, for reasons just explained, it was found impractical to limit the studies to improvements in repairability alone. Some of the concepts have thus focused on reliability improvements as the most direct approach to reducing the man-hour cost of repair.

Among the concepts proposed in the study, some amount to little more than the application of good design practice, or the adoption of a proven design where a deficient one now exists. Others are more ambitious in scope. All of the concepts are well within the reach of current technology. Some may require a significant development effort to prove their worth. Several present significant enough disadvantages to be dismissed without further consideration.

The design concept recommendations were contributed by many different people in the various engineering groups at Kaman. They represent some possible approaches to problems this study has examined. They are not the only solutions, neither are they, perhaps, the ideal solutions in every case. Another group of engineers confronted with the same set of problems would, assuredly, have arrived at a different mix of responses.

## RECOMMENDATIONS

1. With the completion of this study, the third in a series of programs outlined in the introduction to the report, the Army has thoroughly examined the maintenance of major helicopter components in the field. One conclusion of this work has been that major repair of these components, rather than a field function, is accomplished primarily at Depot. It is recommended, therefore, that as the next logical step in the overall program, the Army complete the study of major component maintenance by examining the man-hour cost of Depot repair. The objective, like that of the preceding work, will be to relate repair problems and man-hour costs to specific characteristics of component design, and to develop solutions that will bring about improved designs in the future.
  
2. In the course of this study, a number of concepts having a potentially beneficial effect on the repairability of helicopter components in the future have been advanced. Most of these, if shown to be cost effective, could be adopted with little or no additional development. A modest development effort would be needed for others. It is recommended that the Government pursue further those design concepts that the work accomplished under this program has shown, in its assessment, to offer a significant improvement potential. Four concepts appear, in the Contractor's judgement, especially worthy of further effort:
  1. Ferrofluidic Seal
  2. Lip Seal With Expandable Rubber Retaining Ring
  3. Segmented Servo Head Sleeve for Hydraulic Actuators
  4. Threaded Seats for Swashplate Uniball.

## REFERENCES

1. Cook, T. N., Young, R. L., and Starses, F. E., MAINTAINABILITY ANALYSIS OF MAJOR HELICOPTER COMPONENTS, Kaman Aerospace Corporation; USAAMRDL Technical Report 73-43, Eustis Directorate, U. S. Army Air Mobility Research and Development Laboratory, Fort Eustis, Virginia, August 1973, AD 769941.
2. Cook, T. N., Starses, F. E., and Haire, G. W., ARMY AIRCRAFT SUBSYSTEM AND COMPONENT INSTALLATION DESIGN INVESTIGATION, Kaman Aerospace Corporation; USAAMRDL Technical Report 75-7, Eustis Directorate, U. S. Army Air Mobility Research and Development Laboratory, Fort Eustis, Virginia, February 1975, AD A007245.
3. EXECUTIVE SUMMARY REPORT, CH-47A ASSESSMENT AND COMPARATIVE FLEET EVALUATIONS, USAAVSCOM Technical Report 74-46, U. S. Army Aviation Systems Command, St. Louis, Mo., November 1974.
4. Moskowitz, R., and Ezekiel, D., NON-WEARING FERROFLUIDIC SEALS, Paper 750851, presented at the SAE Off-Highway Vehicle Meeting, Milwaukee, Wisconsin, September 8 - 11, 1975.

APPENDIX A

TABULATED FIELD SURVEY RESULTS

Tables A-1 through A-6 contain the tabulated results of the field surveys for the six helicopter models covered by the study. Each table is arranged by helicopter component and, in descending order of significance, by repair task. Only those tasks meeting the criteria of significantly occurring (5% or more of the total repair actions on a component) are listed.

TABLE A-1. COMPONENT REPAIR DATA, OH-58 HELICOPTER

Component/ Replaced Part	Maint- enance Level	On/ Off Air- craft	Est. Events/ 10,000 Flt-Hrs	Avg. Crew Size	Elements of Replacement Task				
					Hrs. Pct.	Total Task Time	Dis- assy. and Assy.	Adjst, Align, Etc.	Drain Lube Ser- vice
<u>Main Transmission</u>									
Input Seal	D.S.	On	34	2	10.9 Hrs. 91.7 Pct.	10.0 0.3	0.3 2.2	0.6 5.5	
Sight Glass	Org.	On	7	1	0.1 Hrs. 33.3 Pct.	0.1 33.3	0.1 33.3	0.1 33.3	
Oil Filter	Org.	On	3	1	1.7 Hrs. 81.0 Pct.	1.7 2.1	0.2 9.5	0.2 9.5	
<u>Tail Rotor Gearbox</u>									
Input Seal	D.S.	On	23	1	3.4 Hrs. 73.5 Pct.	2.5 3.4	0.1 2.9	0.8 23.5	
Sight Glass	Org.	On	14	1	0.1 Hrs. 33.3 Pct.	0.1 33.3	0.1 33.3	0.1 33.3	
Output Seal	D.S.	On	12	1	2.5 Hrs. 73.5 Pct.	2.5 3.4	0.1 2.9	0.8 23.5	
<u>Main Rotor Hub</u>									
Inboard Grip Seal	D.S.	Off	27	2	13.8 Hrs. 58.0 Pct.	8.0 13.8	4.8 5.1	0.3 2.2	
Grip Reservoir Sight Glass	Org.	On	27	1	0.3 Hrs. 50.0 Pct.	0.3 50.0	0.1 25.0	0.1 25.0	
Outboard Grip Seal	D.S.	Off	10	2	17.0 Hrs. 64.7 Pct.	11.0 17.0	4.7 27.6	0.5 4.7	

TABLE A-1 - Continued

Component/ Replaced Part	Maint- enance Level	On/ Off Air- craft	Est. Events/ 10,000 Flt-Hrs	Avg. Crew Size	Elements of Replacement Task			
					Total Task Time	Dis- assy. and Assy.	Adjst, Align, Etc.	Drain Lube Ser- vice
<u>Main Rotor Hub (Contd.)</u>								
Plastic Cover	Org.	On	6	2	Hrs. Pct.	2.1 95.2	2.0 95.2	0.1 4.8
<u>Tail Rotor Hub</u>								
Trunnion Thrust Bushing	D.S.	Off	65	1	Hrs. Pct.	2.9 69.0	2.0 24.1	0.2 6.9
Teflon Bearing and Housing	D.S.	Off	16	1	Hrs. Pct.	3.6 69.4	2.5 25.0	0.2 5.6
<u>Hydraulic Actuator</u>								
Piston Seals	G.S.	Off	7	1	Hrs. Pct.	5.4 40.7	2.2 40.7	3.2 59.3
Valve Body Seals	G.S.	Off	3	1	Hrs. Pct.	4.4 40.9	1.8 40.9	2.6 59.1
Piston Rod	G.S.	Off	1	1	Hrs. Pct.	3.8 65.8	2.5 65.8	1.3 34.2
<u>Starter/Generator</u>								
Brushes	D.S.	Off	14	1	Hrs. Pct.	1.7 29.4	0.5 29.4	1.2 70.6
Terminal Block	G.S.	Off	6	1	Hrs. Pct.	1.1 90.9	1.0 90.9	0.1 9.1

TABLE A-1 - Continued

Component/ Replaced Part	Maint- enance Level	On/ Off Air- craft	Est. Events/ 10,000 Flt-Hrs	Avg. Crew Size	Elements of Replacement Task						
					Hrs. Pct.	Total Task Time	Dis- assy. and Assy.	Adjst, Align, Etc.	Drain Lube Ser- vice	In- spect and Test	
<u>Starter/Generator (Contd.)</u>											
Armature Bearings	G.S.	Off	4	1	Hrs. Pct.	4.0 75.0	3.0			1.0 25.0	
Input Shaft	G.S.	Off	4	1	Hrs. Pct.	0.8 62.5	0.5			0.3 37.5	
<u>Swashplate and Support Assy.</u>											
Upper Lip Seal	D.S.	Off	4	1	Hrs. Pct.	4.9 71.4	3.5 18.4	0.9 2.0		0.4 8.2	
Uniball Teflon Seats	D.S.	Off	3	1	Hrs. Pct.	5.4 74.1	4.0 13.0	0.7		0.7 13.0	
Collective Lever Assy.	Org.	On	1	1	Hrs. Pct.	2.3 87.0	2.0			0.3 13.0	
Duplex Ball Bearing	D.S.	Off	1	1	Hrs. Pct.	3.3 60.6	2.0 21.2	0.7 3.0		0.1 15.2	

TABLE A-2. COMPONENT REPAIR DATA, OH-6 HELICOPTER

Component/ Replaced Part	Maint- enance Level	On/ Off Air- craft	Est. Events/ 10,000 Flt-Hrs	Avg. Crew Size	Elements of Replacement Task						
					Total Task Time	Dis- assy. and Assy.	Adjst, Align, Etc.	Drain Lube Ser- vice	In- spect and Test		
<u>Main Transmission</u>											
No Data Collected											
<u>Tail Rotor Gearbox</u>											
Output Seal	D.S.	On	8	1	Hrs. 1.7	Hrs. 1.0	Hrs. 0.1	Hrs. 5.9	Hrs. 0.1	Hrs. 0.6	Hrs. 35.3
Chip Detector	Org.	On	4	1	Hrs. 0.2	Hrs. 0.1	Hrs. 0.1	Hrs. 50.0	Hrs. 0.1	Hrs. 50.0	Hrs. 0.1
<u>Main Rotor Hub</u>											
Lead-Lag Blade Stop	D.S.	On	69	1	Hrs. 0.8	Hrs. 0.8	Hrs. 87.5	Hrs. 0.1	Hrs. 12.5	Hrs. 0.1	Hrs. 12.5
<u>Tail Rotor Hub</u>											
Repaired at Depot											
<u>Starter/Generator</u>											
Repaired at Depot											
<u>Swashplate</u>											
No Data Collected											

TABLE A-3. COMPONENT REPAIR DATA, UH-1 HELICOPTER

Component/ Replaced Part	Maint- enance Level	On/ Off Air- craft	Est. Events/ 10,000 Flt-Hrs	Avg. Crew Size	Elements of Replacement Task					
					Hrs. Pct.	Total Task Time	Dis- assy. and Assy.	Adjst., Align, Etc.	Drain Lube Ser- vice	In- spect and Test
<u>Main Transmission</u>										
Chip Detector Seal	Org.	On	56	1	Hrs. Pct.	0.2 50.0	0.1 50.0			0.1 50.0
Input Seal	D.S.	Off	50	1	Hrs. Pct.	2.2 90.9	2.0 90.9			0.2 9.1
Sight Glass	Org.	On	38	1.1	Hrs. Pct.	0.6 50.0	0.3 50.0		0.2 33.3	0.1 16.7
Tail Rotor Output Seal	D.S.	Off	33	1.1	Hrs. Pct.	1.2 75.0	0.9 75.0		0.2 16.7	0.1 8.3
Mast Seal	D.S.	Off	17	1	Hrs. Pct.	0.6 83.3	0.5 83.3			0.1 16.7
<u>Intermediate Gearbox</u>										
Input Seal	D.S.	Off	50	1	Hrs. Pct.	1.6 31.3	0.5 31.3		1.0 62.5	0.1 6.3
Sight Glass	Org.	On	38	1	Hrs. Pct.	0.5 60.0	0.3 60.0		0.1 20.0	0.1 20.0
Output Seal	D.S.	Off	33	1	Hrs. Pct.	1.6 31.3	0.5 31.3		1.0 62.5	0.1 6.3
<u>Tail Rotor Gearbox</u>										
Input Seal	D.S.	Off	50	1	Hrs. Pct.	1.6 31.3	0.5 31.3		1.0 62.5	0.1 6.3

TABLE A-3 - Continued

Component/ Replaced Part	Maint- enance Level	On/ Off Air- craft	Est. Events/ 10,000 Flt-Hrs	Avg. Crew Size	Elements of Replacement Task						
					Hrs. Pct.	Total Task Time	Dis- assy. and Assy.	Adjst, Align, Etc.	Drain Lube Ser- vice	In- spect and Test	
<u>Tail Rotor Gearbox</u> (Contd.)											
Sight Glass	Org.	On	38	1	Hrs. Pct.	0.5 60.0	0.3 60.0	0.1 20.0	0.1 20.0	0.1 20.0	
Output Seal	D.S.	Off	33	1	Hrs. Pct.	2.1 95.2	2.0 95.2	0.1 4.8	0.1 4.8	0.1 4.8	
<u>Main Rotor Hub</u>											
Grip Seals	D.S.	Off	71	2	Hrs. Pct.	18.2 71.4	13.0 71.4	2.2 12.1	0.7 4.4	2.3 12.6	
Trunnion Reservoir	Org.	On	17	1	Hrs. Pct.	0.6 66.7	0.5 66.7	0.1 16.7	0.1 16.7	0.1 16.7	
Grip Reservoir	Org.	On	8	1	Hrs. Pct.	0.8 62.5	0.5 62.5	0.2 25.0	0.2 25.0	0.1 12.5	
Grip Reservoir Seals	Org.	On	8	1	Hrs. Pct.	0.6 66.7	0.4 66.7	0.2 33.3	0.2 33.3	0.1 16.7	
Trunnion Reservoir Seals	Org.	On	7	1	Hrs. Pct.	0.7 71.4	0.5 71.4	0.1 14.3	0.1 14.3	0.1 14.3	
<u>Tail Rotor Hub</u>											
Duplex Thrust Bearing	D.S.	Off	1	1	Hrs. Pct.	3.6 47.2	1.7 47.2	1.4 38.9	0.1 2.8	0.4 11.1	

TABLE A-3 - Continued

Component/ Replaced Part	Maint- enance Level	On/ Off Air- craft	Est. Events/ 10,000 Flt-Hrs	Avg. Crew Size	Elements of Replacement Task					
					Total Task Time	Dis- assy. and Assy.	Adjst, Align, Etc.	Drain Lube Ser- vice	In- spect and Test	
<u>Tail Rotor Hub (Contd.)</u>										
Trunnion Bearing and Housing	D.S.	Off	1	1	Hrs. Pct.	3.1 48.4	1.5 41.9	1.3 3.2	0.1 6.5	0.2
<u>Hydraulic Actuators</u>										
Upper Rubber Boot	D.S.	On	50	1	Hrs. Pct.	1.6 93.8	1.5			0.1 6.3
Piston Seals	G.S.	Off	38	1	Hrs. Pct.	5.4 55.6	3.0	0.1 1.9	2.3 42.6	
Lower Rubber Boot	D.S.	On	25	1	Hrs. Pct.	1.6 93.8	1.5			0.1 6.3
Head and Pilot Valve Seals	G.S.	Off	20	1	Hrs. Pct.	5.1 52.9	2.7	0.1 2.0	2.3 45.1	
<u>Starter/Generator</u>										
Brushes	D.S.	Off	9	1	Hrs. Pct.	10.8 47.2	5.1 0.9	0.1		5.6 51.9
Capacitors	G.S.	Off	9	1	Hrs. Pct.	11.8 43.2	5.1 0.8	0.1		6.6 55.9
Terminal Block	G.S.	Off	4	1	Hrs. Pct.	10.6 51.9	5.5 0.9	0.1		5.0 47.2

TABLE A-3 - Continued

Component/ Replaced Part	Maint- enance Level	On/ Off Air- craft	Est. Events/ 10,000 Flt-Hrs	Avg. Crew Size	Elements of Replacement Task			
					Hrs. Pct.	Total Task Time	Dis- assy. and Assy.	Adjst, Align, Etc.
<u>Starter/Generator (Contd.)</u>								
Shaft	D.S.	Off	3	1	10.7 Hrs. Pct.	5.5 51.4	0.1 0.9	5.1 47.7
Armature Bearings	G.S.	Off	3	1	12.6 Hrs. Pct.	7.0 55.6	0.1 0.8	5.5 43.7
Fan Cover	G.S.	Off	2	1	10.4 Hrs. Pct.	5.3 51.0	0.1 1.0	5.0 48.1
<u>D.C. Generator</u>								
Brushes	D.S.	Off	9	1	10.8 Hrs. Pct.	5.1 47.2	0.1 0.9	5.6 51.9
Terminal Block	G.S.	Off	4	1	10.6 Hrs. Pct.	5.5 51.9	0.1 0.9	5.0 47.2
Shaft	D.S.	Off	3	1	10.7 Hrs. Pct.	5.5 51.4	0.1 0.9	5.1 47.7
Armature Bearings	G.S.	Off	3	1	12.6 Hrs. Pct.	7.0 55.6	0.1 0.8	5.5 43.7
Fan Cover	G.S.	Off	2	1	10.4 Hrs. Pct.	5.3 51.0	0.1 1.0	5.0 48.1

TABLE A-3 - Continued

Component/ Replaced Part	Maint- enance Level	On/ Off Air- craft	Est. Events/ 10,000 Flt-Hrs	Avg. Crew Size	Elements of Replacement Task						
					Total Task Time	Dis- assy. and Assy.	Adjst, Align, Etc.	Drain Lube Ser- vice	In- spect and Test		
<u>Swashplate and Collective Sleeve Assy.</u>											
Trunnion Bearings	Org.	On	17	1	0.6	0.4		0.1	0.1		0.1
						66.7		16.7	16.7		
Upper and Lower Seals	D.S.	Off	10	1	4.3	3.3	0.4	0.1	0.5		
						76.7	9.3	2.3	11.6		
Gimbal Ring Bearing	D.S.	Off	8	1	3.3	2.7	0.3		0.3		0.3
						81.8	9.1		9.1		

TABLE A-4. COMPONENT REPAIR DATA, AH-1 HELICOPTER

Component/ Replaced Part	Maint- enance Level	On/ Off Air- craft	Est. Events/ 10,000 Flt-Hrs	Avg. Crew Size	Elements of Replacement Task				
					Hrs. Pct.	Total Task Time	Dis- assy. and Assy.	Adjst., Align, Etc.	Drain Lube Ser- vice
<u>Main Transmission</u>									
Chip Detector Seal	Org.	On	56	1	Hrs. Pct.	0.2 50.0	0.1 50.0	0.1 50.0	0.1 50.0
Input Seal	D.S.	Off	50	1	Hrs. Pct.	2.2 90.9	2.0 90.9	0.2 9.1	0.2 9.1
Sight Glass	Org.	On	38	1.1	Hrs. Pct.	0.6 50.0	0.3 50.0	0.2 33.3	0.1 16.7
Tail Rotor Output Seal	D.S.	Off	33	1.1	Hrs. Pct.	1.2 75.0	0.9 75.0	0.2 16.7	0.1 8.3
Mast Seal	D.S.	Off	17	1	Hrs. Pct.	0.6 83.3	0.5 83.3	0.1 16.7	0.1 16.7
<u>Intermediate Gearbox</u>									
Input Seal	D.S.	Off	50	1	Hrs. Pct.	1.6 31.3	0.5 31.3	1.0 62.5	0.1 6.3
Sight Glass	Org.	On	38	1	Hrs. Pct.	0.5 60.0	0.3 60.0	0.1 20.0	0.1 20.0
Output Seal	D.S.	Off	33	1	Hrs. Pct.	1.6 31.3	0.5 31.3	1.0 62.5	0.1 6.3
<u>Tail Rotor Gearbox</u>									
Input Seal	D.S.	Off	50	1	Hrs. Pct.	1.6 31.3	0.5 31.3	1.0 62.5	0.1 6.3

TABLE A-4 - Continued

Component/ Replaced Part	Maint- enance Level	On/ Off Air- craft	Est. Events/ 10,000 Flt-Hrs	Avg. Crew Size	Elements of Replacement Task				
					Hrs. Pct.	Total Task Time	Dis- assy. Align, Etc.	Drain Lube Ser- vice	In- spect and Test
<u>Tail Rotor Gearbox (Contd.)</u>									
Sight Glass	Org.	On	38	1	Hrs. Pct.	0.5 60.0	0.3 20.0	0.1 20.0	0.1 20.0
Output Seal	D.S.	Off	33	1	Hrs. Pct.	2.1 95.2	2.0 95.2	0.1 4.8	0.1 4.8
<u>Main Rotor Hub</u>									
Trunnion Teflon Bearings	D.S.	Off	5	2	Hrs. Pct.	7.2 83.3	6.0 12.5	0.9 4.2	0.3 4.2
Grip Teflon Bearings	D.S.	Off	3	2	Hrs. Pct.	9.7 82.5	8.0 14.4	1.4 3.1	0.3 3.1
Sand Deflector	Org.	On	2	1	Hrs. Pct.	0.6 83.3	0.5 16.7	0.1 16.7	0.1 16.7
Buffer Pads	D.S.	Off	2	2	Hrs. Pct.	6.5 76.9	5.0 21.5	1.4 1.5	0.1 1.5
Tension-Torsion Strap	D.S.	Off	2	2	Hrs. Pct.	8.7 80.5	7.0 16.1	1.4 3.4	0.3 3.4
<u>Tail Rotor Hub</u>									
Duplex Thrust Bearing	D.S.	Off	1	1	Hrs. Pct.	3.6 47.2	1.7 38.9	0.1 2.8	0.4 11.1

TABLE A-4 - Continued

Component/ Replaced Part	Maint- enance Level	On/ Off Air- craft	Est. Events/ 10,000 Flt-Hrs	Avg. Crew Size	Elements of Replacement Task					
					Hrs. Pct.	Total Task Time	Dis- assy. and Assy.	Adjst, Align, Etc.	Drain Lube Ser- vice	In- spect and Test
<u>Tail Rotor Hub (Contd.)</u>										
Trunnion Bearing and Housing	D.S.	Off	1	1	Hrs. Pct.	3.1	1.5 48.4	1.3 41.9	0.1 3.2	0.2 6.5
<u>Hydraulic Actuators</u>										
Piston Seals	G.S.	Off	67	1	Hrs. Pct.	8.4	5.5 65.5		0.1 1.2	2.8 33.3
Upper Rubber Boot	D.S.	On	50	1	Hrs. Pct.	1.6	1.5 93.8			0.1 6.3
Spool and Head Seals	G.S.	Off	29	1	Hrs. Pct.	9.1	6.5 71.4		0.1 1.1	2.5 27.5
Lower Rubber Boot	D.S.	On	25	1	Hrs. Pct.	1.6	1.5 93.8			0.1 6.3
Uniball Seats	G.S.	Off	10	1	Hrs. Pct.	5.2	2.2 42.3	0.3 5.8	0.1 1.9	2.6 50.0
<u>Starter/Generator</u>										
Brushes	D.S.	Off	9	1	Hrs. Pct.	10.8	5.1 47.2	0.1 0.9		5.6 51.9
Capacitors	G.S.	Off	9	1	Hrs. Pct.	11.8	5.1 43.2	0.1 0.8		6.6 55.9

TABLE A-4 - Continued

Component/ Replaced Part	Maint- enance Level	On/ Off Air- craft	Est. Events/ 10,000 Flt-Hrs	Avg. Crew Size	Elements of Replacement Task				
					Total Task Time	Dis- assy. and Assy.	Adjst, Align, Etc.	Drain Lube Ser- vice	In- spect and Test
<u>Starter/Generator (Contd.)</u>									
Terminal Block	G.S.	Off	4	1	Hrs. Pct.	10.6 51.9	5.5 0.9	0.1 0.9	5.0 47.2
Shaft	D.S.	Off	3	1	Hrs. Pct.	10.7 52.4	5.5 0.9	0.1 0.9	5.1 47.7
Armature Bearings	G.S.	Off	3	1	Hrs. Pct.	12.6 55.6	7.0 0.8	0.1 0.8	5.5 43.7
Fan Cover	G.S.	Off	2	1	Hrs. Pct.	10.4 51.0	5.3 1.0	0.1 1.0	5.0 48.1
<u>Swashplate and Support Assy.</u>									
Upper and Lower Seals	D.S.	Off	10	1	Hrs. Pct.	4.5 80.0	3.6 8.9	0.4 2.2	0.4 8.9
Uniball Teflon Seats	D.S.	Off	4	1	Hrs. Pct.	5.1 78.4	4.0 9.8	0.5 2.0	0.5 9.8
Large Duplex Bearing	D.S.	Off	2	1	Hrs. Pct.	6.7 82.1	5.5 6.0	0.4 1.5	0.7 10.4
Top Sheet Metal Shield	D.S.	Off	1	1	Hrs. Pct.	0.6 50.0	0.3 33.3	0.2 33.3	0.1 16.7

TABLE A-5. COMPONENT REPAIR DATA, CH-47 HELICOPTER

Component/ Replaced Part	Maint- enance Level	On/ Off Air- craft	Est. Events/ 10,000 Flt-Hrs	Avg. Crew Size	Elements of Replacement Task				
					Hrs. Pct.	Total Task Time	Dis- assy. and Assy.	Adjst., Align, Etc.	Drain In- spect and Test
<u>Forward Transmission</u>									
Input Seal	Org.	On	9	2	6.6 90.9	6.0 90.9			0.6 9.1
Sight Glass	Org.	On	8	1.1	1.8 44.4	0.8 44.4		0.7 38.9	0.3 16.7
Output Seal	D.S.	On	5	4	19.3 82.8	15.9 82.8		1.0 5.2	2.4 12.4
Magnetic Chip Detector	Org.	On	5	1	0.5 80.0	0.4 80.0			0.1 20.0
<u>Aft Transmission</u>									
Accessory Drive Seals	Org.	On	35	1.3	3.1 87.1	2.7 87.1			0.4 12.9
Sight Glass	Org.	On	8	1.1	1.9 42.1	0.8 42.1		0.8 42.1	0.3 15.8
Input Seal	Org.	On	8	1.7	6.1 88.5	5.4 88.5		0.1 1.6	0.6 9.8
Magnetic Chip Detector	D.S.	On	7	1	0.5 80.0	0.4 80.0			0.1 20.0
<u>Combining Transmission</u>									
Sight Glass	Org.	On	10	1	1.6 37.5	0.6 37.5		0.8 50.0	0.2 12.5

TABLE A-5 - Continued

Component/ Replaced Part	Maint- enance Level	On/ Off Air- craft	Est. Events/ 10,000 Flt-Hrs	Avg. Crew Size	Elements of Replacement Task					
					Hrs. Pct.	Total Task Time	Dis- assy. and Assy.	Adjst, Align, Etc.	Drain In- spect and Test	
<u>Combining Transmission</u> (Contd.)										
Output Seal	Org.	On	10	1.8	1.8 Hrs. Pct.	5.3	4.0 75.5	0.2 3.8	0.2 3.8	0.9 17.0
Input Seal	Org.	On	8	1.3	1.3 Hrs. Pct.	5.3	3.2 60.4	1.0 18.9	0.3 5.7	0.8 15.1
Oil Filler Cap	D.S.	On	7	1	1 Hrs. Pct.	0.3	0.2 66.7			0.1 33.3
Oil Filter Attach Studs	D.S.	Off	5	1	1 Hrs. Pct.	3.9	2.5 64.1		0.5 12.8	0.9 23.1
Reservoir Gasket	D.S.	On	4	1.5	1.5 Hrs. Pct.	4.9	4.0 81.6		0.2 4.1	0.7 14.3
<u>Rotor Head</u>										
Vertical Hinge Pin Seal	D.S.	On	148	1.5	1.5 Hrs. Pct.	6.3	5.3 84.1		0.8 12.7	0.2 3.2
Horizontal Hinge Pin Seal	D.S.	Off	66	2	2 Hrs. Pct.	21.2	18.0 84.9	0.2 0.9	1.5 7.1	1.5 7.1
Sight Glass	Org.	On	58	1	1 Hrs. Pct.	1.0	0.1 10.0		0.8 80.0	0.1 10.0
Pitch Varying Housing Seal	D.S.	Off	40	2	2 Hrs. Pct.	12.8	11.5 89.8		0.9 7.0	0.4 3.1

TABLE A-5 - Continued

Component/ Replaced Part	Maint- enance Level	On/ Off Air- craft	Est. Events/ 10,000 Flt-Hrs	Avg. Crew Size	Elements of Replacement Task									
					Total Task Time	Dis- assy. Align, Etc.	Drain Lube Ser- vice	In- spect and Test	Hrs. Pct.					
<u>Auxiliary Power Plant</u>														
Combustor Housing Assy.	D.S.	Off	11		2.8	1.8	0.5	0.3	0.2	Hrs. Pct.	64.3	17.9	10.7	7.1
Fuel Lines From Control to Injectors	D.S.	On	7		0.3	0.2			0.1	Hrs. Pct.	66.7			33.3
Combustor Liner and Fireshield	D.S.	Off	6		3.1	1.5	0.8	0.4	0.4	Hrs. Pct.	48.4	25.8	12.9	12.9
Fuel Pressure Switch	Org.	On	5		0.9	0.3			0.6	Hrs. Pct.	33.3			66.7
Oil Pressure Switch	Org.	On	4		0.9	0.3			0.6	Hrs. Pct.	33.3			66.7
EGT Overtemp Safety Switch	Org.	On	3		0.2	0.1			0.1	Hrs. Pct.	50.0			50.0
<u>Hydraulic Actuators</u>														
No Data Collected														
<u>AC Generators</u>														
No Data Collected														

TABLE A-5 - Continued

Component/ Replaced Part	Maint- enance Level	On/ Off Air- craft	Est. Events/ 10,000 Flt-Hrs	Avg. Crew Size	Elements of Replacement Task				
					Total Task Time	Dis- assy. and Assy.	Adjst, Align, Etc.	Drain Lube Ser- vice	In- spect and Test
<u>Swashplate Assy.</u>									
Uniball Teflon Seats	D.S.	Off	11	1	1.3 Hrs. Pct.	1.0 76.9			0.3 23.1
Slider Teflon Bearings	D.S.	Off	8	1.5	9.0 Hrs. Pct.	8.1 90.0	0.1 1.1		0.8 8.9
Lower Lip Seal	D.S.	Off	5	1	3.0 Hrs. Pct.	2.6 86.7		0.2 6.7	0.2 6.7

TABLE A-6. COMPONENT REPAIR DATA, CH-54 HELICOPTER

Component/ Replaced Part	Maint- enance Level	On/ Off Air- craft	Est. Events/ 10,000 Flt-Hrs	Avg. Crew Size	Elements of Replacement Task					
					Hrs. Pct.	Total Task Time	Dis- assy. and Assy.	Adjst. Align. Etc.	Drain Lube Ser- vice	In- spect and Test
<u>Main Transmission</u>										
Input Seal	D.S.	On	109	3.5	3.5 Hrs. Pct.	29.0	27.0 93.1	0.6 2.1		1.4 4.8
Rotor Brake Shaft Seal	D.S.	On	43	2	2 Hrs. Pct.	9.1	8.0 87.9		0.1 1.1	1.0 11.0
Tail Rotor Take-Off Seal	D.S.	On	38	1.5	1.5 Hrs. Pct.	6.2	5.5 88.7			0.7 11.3
<u>Intermediate Gearbox</u>										
Input Seal	D.S.	Off	49	2	2 Hrs. Pct.	3.0	2.0 66.7		0.1 3.3	0.9 30.0
Output Seal	D.S.	On	49	2	2 Hrs. Pct.	5.1	4.0 78.4			1.1 21.6
<u>Tail Rotor Gearbox</u>										
Input Seal	D.S.	On	64	1.8	1.8 Hrs. Pct.	5.5	4.5 81.8		0.4 7.3	0.6 10.9
Output Seal	D.S.	On	6	2	2 Hrs. Pct.	60.0	53.0 88.3	3.0 5.0		4.0 6.7
Servo Linkage	D.S.	On	6	1	1 Hrs. Pct.	10.6	5.0 47.2	3.0 28.3		2.6 24.5

TABLE A-6 - Continued

Component/ Replaced Part	Maint- enance Level	On/ Off Air- craft	Est. Events/ 10,000 Flt-Hrs	Avg. Crew Size	Elements of Replacement Task				
					Hrs. Pct.	Total Task Time	Dis- assy. and Assy.	Adjst, Align, Etc.	Drain Lube Ser- vice
<u>Main Rotor Head</u>									
Rubber Boots on Pitch Change Links	Org.	On	154	1	Hrs. Pct.	2.6 38.5	1.0 38.5	1.6 61.5	
Bits and Pieces of Droop Stop Assy.	D.S.	On	106	1.5	Hrs. Pct.	2.7 81.5	2.2 81.5	0.5 18.5	
Damper Bearings	D.S.	Off	73	1	Hrs. Pct.	1.1 36.4	0.4 36.4	0.7 63.6	
Pitch Change Links	Org.	On	38	1	Hrs. Pct.	6.0 50.0	1.0 50.0	2.0 33.3	
<u>Tail Rotor Head</u>									
Rubber Bumpers	Org.	On	62	1	Hrs. Pct.	1.1 27.3	0.3 27.3	0.8 72.7	
Pitch Change Link	Org.	On	62	1	Hrs. Pct.	3.3 48.5	0.6 48.5	1.1 33.3	
Rod End on Pitch Change Link	Org.	On	14	1	Hrs. Pct.	1.7 58.8	0.5 58.8	0.2 11.8	
<u>Auxiliary Power Plant</u>									
110 psi fuel Pressure Switch	Org.	On	19	1	Hrs. Pct.	1.0 40.0	0.4 40.0	0.6 60.0	

TABLE A-6 - Continued

Component/ Replaced Part	Maint- enance Level	On/ Off Air- craft	Est. Events/ 10,000 Flt-Hrs	Avg. Crew Size	Elements of Replacement Task					
					Hrs. Pct.	Total Task Time	Dis- assy. and Assy.	Adjst, Align, Etc.	Drain Lube Ser- vice	In- spect and Test
<u>Auxiliary Power Plant (Contd.)</u>										
90% Speed Switch	Org.	On	11	1	Hrs. Pct.	1.7 47.1	0.8 0.9	0.3 0.9	7.7 23.1	52.9
Fuel Control	Org.	On	10	1	Hrs. Pct.	3.9 61.5	2.4 0.3	0.3 7.7	0.3 7.7	0.9 23.1
Starting Fuel Solenoid	Org.	On	9	1	Hrs. Pct.	1.3 38.5	0.5 0.8			0.8 61.5
Main Fuel Solenoid	Org.	On	9	1	Hrs. Pct.	1.3 38.5	0.5 0.8			0.8 61.5
Oil Pressure Switch	Org.	On	5	1	Hrs. Pct.	0.8 50.0	0.4 0.4			0.4 50.0
Ignitor Plug	Org.	On	4	1	Hrs. Pct.	1.0 20.0	0.2 0.8			0.8 80.0
<u>Hydraulic Actuators</u>										
Follow-up Rod	D.S.	On	91	1	Hrs. Pct.	3.3 60.6	2.0 39.4			1.3 39.4
<u>AC Generator</u>										
Plastic Terminal Covers	Org.	On	30	1	Hrs. Pct.	0.5 80.0	0.4 0.1			0.1 20.0

TABLE A-6 - Continued

Component/ Replaced Part	Maint- enance Level	On/ Off Air- craft	Est. Events/ 10,000 Flt-Hrs	Avg. Crew Size	Elements of Replacement Task						
					Hrs. Pct.	Total Task Time	Dis- assy. and Assy.	Adjst, Align, Etc.	Drain Lube Ser- vice	In- spect and Test	
<u>Swashplate Assy.</u>											
Rotating Scissors	D.S.	On	44	2	17.8 Hrs. 10.1 Pct.	16.0 89.9				1.8 10.1	
Teflon Bearings in Rotating Scissors	D.S.	On	22	1	6.8 Hrs. 26.5 Pct.	5.0 73.5				1.8 26.5	
Stationary Scissors	D.S.	On	7	1	9.8 Hrs. 18.4 Pct.	8.0 81.6				1.8 18.4	