

AD-A035 154

ARMY ENGINEER TOPOGRAPHIC LABS FORT BELVOIR VA
HOLOGRAPHIC TERRAIN DISPLAYS, (U)
OCT 76 M M MCDONNELL

F/G 8/2

UNCLASSIFIED

ETL-0083

NL

1 OF 1
AD-A
035 154



END
DATE
FILMED
3-15-77
NTIS

U.S. DEPARTMENT OF COMMERCE
National Technical Information Service

AD-A035 154

HOLOGRAPHIC TERRAIN DISPLAYS

ARMY ENGINEER TOPOGRAPHIC LABORATORIES
FORT BELVOIR, VIRGINIA

OCTOBER 1976

ETL - 0083

ADA035154

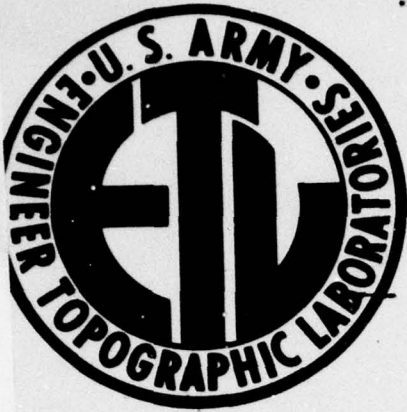

HOLOGRAPHIC TERRAIN DISPLAYS

October 1976

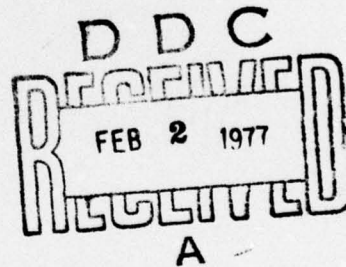

Approved for public release; distribution unlimited.

REPRODUCED BY
NATIONAL TECHNICAL
INFORMATION SERVICE
U. S. DEPARTMENT OF COMMERCE
SPRINGFIELD, VA. 22161

**U.S. ARMY ENGINEER
TOPOGRAPHIC LABORATORIES
FORT BELVOIR, VA 22060**

Destroy this report when it is no longer needed.
Do not return it to the originator.

The citation in this report of trade names of commercially available products does not constitute official endorsement or approval of the use of such products.

UNCLASSIFIED

SECURITY CLASSIFICATION OF THIS PAGE (When Data Entered)

REPORT DOCUMENTATION PAGE		READ INSTRUCTIONS BEFORE COMPLETING FORM
1. REPORT NUMBER ETL-0083	2. GOVT ACCESSION NO.	3. RECIPIENT'S CATALOG NUMBER
4. TITLE (and Subtitle) HOLOGRAPHIC TERRAIN DISPLAYS		5. TYPE OF REPORT & PERIOD COVERED
		6. PERFORMING ORG. REPORT NUMBER
7. AUTHOR(s) Michael M. McDonnell		8. CONTRACT OR GRANT NUMBER(s)
9. PERFORMING ORGANIZATION NAME AND ADDRESS U.S. Army Engineer Topographic Laboratories Fort Belvoir, Virginia 22060		10. PROGRAM ELEMENT, PROJECT, TASK AREA & WORK UNIT NUMBERS Project: 4A161102B52C Task: 03 Work Unit: 1452C030019
11. CONTROLLING OFFICE NAME AND ADDRESS U.S. Army Engineer Topographic Laboratories Fort Belvoir, Virginia 22060		12. REPORT DATE October 1976
		13. NUMBER OF PAGES 46
14. MONITORING AGENCY NAME & ADDRESS (if different from Controlling Office)		15. SECURITY CLASS. (of this report) Unclassified
		15a. DECLASSIFICATION/DOWNGRADING SCHEDULE
16. DISTRIBUTION STATEMENT (of this Report) Approved for public release; distribution unlimited.		
17. DISTRIBUTION STATEMENT (of the abstract entered in Block 20, if different from Report)		
18. SUPPLEMENTARY NOTES		
19. KEY WORDS (Continue on reverse side if necessary and identify by block number) Holography, terrain displays, holographic stereomodel, photointerpreter aids.		
20. ABSTRACT (Continue on reverse side if necessary and identify by block number) The suitability of holography as a method for recording and reproducing visual displays of terrain is examined in a tutorial, non-mathematical manner. The paper is based chiefly on a literature search combined with some original work by the author. A brief introduction to the terminology of holography is followed by an exposition of a scheme of classifying hologram types which is used in the rest of the paper. Consideration of requirements for 3-D displays in general and the particular problem of making holograms of terrain is followed by a detailed discussion of the different types of hologram and how they may		

DD FORM 1473 1 JAN 73 EDITION OF 1 NOV 65 IS OBSOLETE

UNCLASSIFIED
SECURITY CLASSIFICATION OF THIS PAGE (When Data Entered)

Cont'd

UNCLASSIFIED

SECURITY CLASSIFICATION OF THIS PAGE(When Data Entered)

20. ABSTRACT.

be used to make terrain displays with different characteristics. Emphasis is on the 2-photograph stereoscopic hologram which is called a "holographic stereomodel". Techniques to enhance certain characteristics of holographic displays such as color rendition and efficient use of illumination are examined and possible uses of holography in tasks related to map making are suggested.

SEARCHED	INDEXED
SERIALIZED	FILED
BY	
DISTRIBUTION/AVAILABILITY STATEMENT	
DOWNSIDE	
APPROVAL FOR EXPORT	
A	

1a

UNCLASSIFIED

SECURITY CLASSIFICATION OF THIS PAGE(When Data Entered)

CONTENTS

Section	Title	Page
I	INTRODUCTION	1
II	HOLOGRAPHY	
	Background and Theory	1
	Light and Photography	1
	Interference and Diffraction of Coherent Light	2
	Holography	3
	Bragg Diffraction	7
	Multiple Recording	8
	Classification of Holograms	10
	Recording Position	10
	Interference Pattern	12
III	HOLOGRAPHIC TERRAIN DISPLAYS	15
	Continuous Perspective Models	16
	Cylindrical Film	16
	Close Proximity Technique	19
	Composite Holograms	19
	The Holographic Stereomodel	19
	Fresnel Case	20
	Fourier Transform Hologram	25
	Focused Image	27
	Carrier Frequency Photography	29
IV	OTHER USEFUL TECHNIQUES	
	Amplitude and Phase Encoding	37
	Color Displays	38
V	SUMMARY AND DISCUSSION	
	Summary	41
	Discussion	44
VI	CONCLUSIONS	45

ILLUSTRATIONS

Figures	Title	Page
1.	Constructive (top) and destructive interference	2
2.	Uniform parallel fringes produced by the interference of two plane waves	3
3.	Generation of zero and first order waves by grating	4
4.	Holographic recording of three-dimensional object	5
5.	Reconstruction of images from hologram	6
6.	Diffraction of light by a thick film grating	7
7.	Three methods of recording more than one hologram on a single plate	9
8.	Imaging geometry	11
9.	Representative locations for recording holograms	11
10.	A particular cross-section of the family of maximum intensity contour surfaces	13
11.	Cylindrical film hologram	17
12.	Close proximity holography	17
13.	Recording geometry for close proximity holography	18
14.	Recording and reconstructing the Fresnel holographic stereomodel	22-23
15.	The field of view effect of real versus virtual image reconstruction of focused-image holograms	28
16.	Dispersion of white light from a focused-image hologram	30

ILLUSTRATIONS (Cont'd)

Figures	Title	Page
17.	Holographic stereomodel viewing apertures created through the use of spherical reference beams	32
18.	CFP made by contact printing	34
19.	Illumination by a diffuse light source	35
20.	Competition effects between bright and dark features	36
21.	Black and white hologram image	41

HOLOGRAPHIC TERRAIN DISPLAYS

I. INTRODUCTION

The US Army Engineer Topographic Laboratories has been supporting research in coherent optics applied to mapping since 1970. One aspect of this work has been the use of holography as a three-dimensional terrain display medium. This report is on the recording and projecting of holographic 3-D terrain displays having potential applications in photointerpretation and mapping. Attention is given to the basic holographic configurations rather than display device techniques since the latter can vary widely with specific applications even though the principles used in displays are general.

In the treatment of holography presented, generally valid simplifications are used such as assumed-linearity of recording media. If the reader is interested in a more detailed and mathematical treatment of holography, he should consult Collier¹ and Goodman² which have been the most useful references for this author.

An overview of holography and of the different types of holograms is followed by a consideration of 3-D displays and methods of encoding distant scenes holographically. Techniques for multiplexing and for the recording of black and white and color information are examined and a discussion of the advantages and disadvantages of selected types of holograms for terrain display is presented.

II. HOLOGRAPHY

Background and Theory

Light and Photography: When light is transmitted through a transparency or reflected from a solid object, it picks up information from this interaction and propagates outward, carrying information in the form of an optical field or radiation pattern. It is the function of a recording medium to encode this optical field so that it can be reproduced. Conventional photography can record some characteristics of this optical field, but a hologram records all of it and reproduces an arbitrary optical field with the limitation that, in most cases, coherent light from a laser must be used to record and reproduce the hologram.

The important characteristic of holography, as opposed to photography, is that holographic techniques enable the phase of a wavefront to be recorded and reproduced.

¹ R. J. Collier, C. B. Burkhardt, and L. H. Lin, *Optical Holography*, Academic Press, New York, 1971.

² J. W. Goodman, *Introduction to Fourier Optics*, McGraw-Hill, San Francisco, 1968.

This is important because an optical field is characterized by a complex function containing amplitude and phase terms, and the phase term carries positional information.

It is impossible to record this field directly since all light sensors, including photographic film, are "square law" detectors which means they cannot detect the phase of the optical field being recorded. For this reason conventional photographs are recorded at an image plane where the optical field is characterized without reference to the phase. Although the wavefront phase still exists at an image plane, it is not needed as a carrier of pictorial information. Outside the image plane, the phase of the field must be recorded to reconstruct the image. Holography has made this possible.

Interference and Diffraction of Coherent Light. The propagation of light is a wave phenomenon. The interference of two intersecting light waves may be either constructive or destructive, depending on the phase relationships between the waves (figure 1).

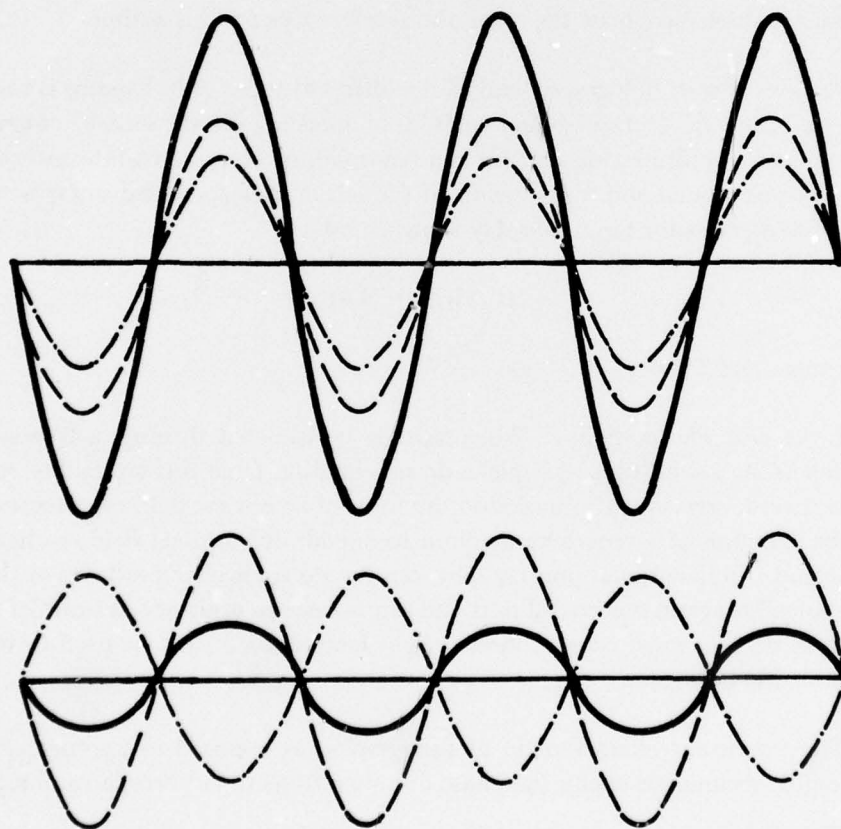

Figure 1. Constructive (top) and Destructive Interference

The interference pattern formed between coherent light beams is stationary in time and space and can therefore be recorded on a sensitive medium. When two coherent light beams intersect, their phase relationships change with distance across the intersection as a function of the angle between the beams. If a photographic plate is placed in the volume where the two beams intersect, it will be exposed in regions of constructive interference and not exposed in regions of destructive interference (figure 2).

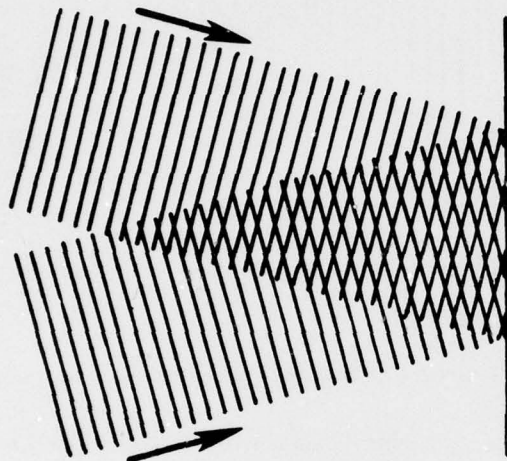

Figure 2. Uniform Parallel Fringes Produced by the Interference of Two Plane Waves

Since interference gradually shifts from constructive to destructive, the resulting recording will be a sinusoidal pattern of dark and clear areas which are called "fringes." These fringes form a sinusoidal diffraction grating on the plate.

If the sinusoidal diffraction grating is transilluminated by a collimated monochromatic light beam, three beams can be detected as shown in figure 3.

Holography. The recording of a hologram is similar to the recording of a simple diffraction grating except that one of the interfering beams is modulated by reflection from a solid object or by transmission through a photographic transparency (figure 4). This modulated beam is called the *object beam* and the unmodulated beam is called the *reference beam*. Modulation of a beam affects its phase and amplitude characteristics, which in turn affects the interference pattern between the two beams. Phase variations in the object beam cause localized shifts of the spacing of fringes, while variations in amplitude cause changes in the contrast of the grating. Therefore both the amplitude and the phase of the object beam have been encoded in the fringe pattern in a way that can be recorded by a square-law detector.

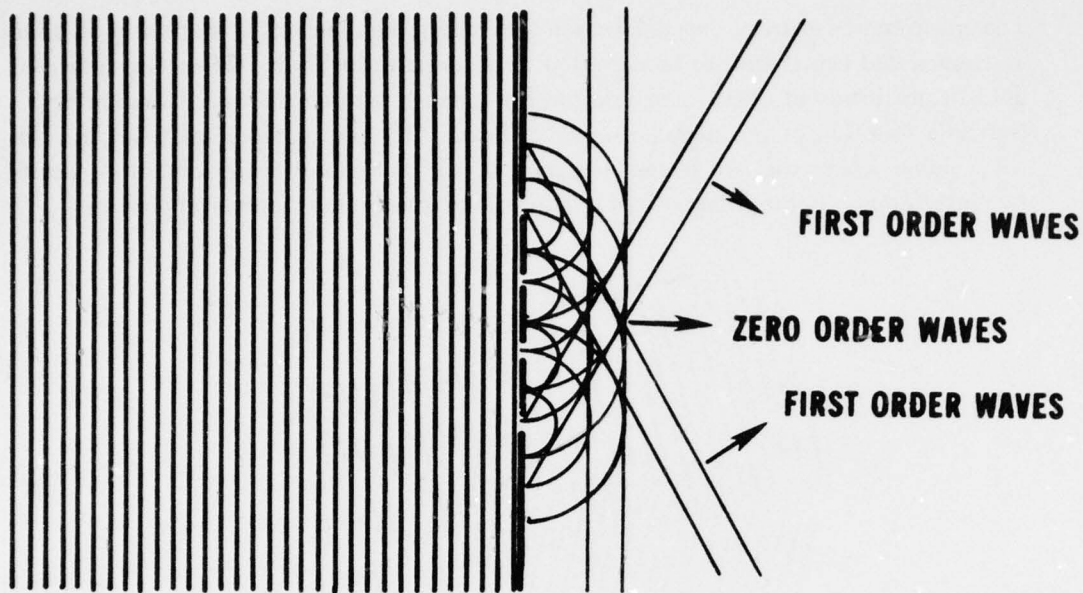

Figure 3. Generation of Zero and First Order Waves by Grating

To exactly reproduce the object beam from the developed hologram, it must be illuminated by a light beam that is exactly the same in wavelength, divergence, and angle of incidence as the reference beam that was used in recording.³ This illumination is called the *reconstruction beam*. The amplitude and phase variations in the hologram grating diffract the reconstruction beam through a range of angles in such a way that the object beam optical field is exactly reproduced or *reconstructed*.

Because a hologram will deflect a light beam in two directions, we have two reconstructed wavefronts. One of these wavefronts is exactly the same as the original object beam. The other is reversed in its curvature from that of the object beam. The hologram object is imaged in space by the converging reconstruction beam such that a photograph of the image may be taken by simply placing a film at the image location. This beam forms the *real image*. The other reconstructed beam is a true reconstruction of the light as it propagated away from the object. From this diverging wavefront the *virtual image* can be formed by using a lens, such as the observer's eye. Figure 5 illustrates the formation of the real and virtual images in the reconstruction process.

Historically, the first holograms used a reference beam collinear with the object beam and in reconstruction, the real and virtual images were superimposed.⁴ By

³ G. G. Glaser and E. M. Mikhail, *Study of Potential Application of Holographic Techniques to Mapping*, U.S. Army Engineer Topographic Laboratories, Fort Belvoir, VA., [p. 84] AD ETL-CR-70-8 718 084 p. 84.

⁴ D. Gabor, "A New Microscopic Principle," *Nature* Vol. 161, 1948, p. 777.

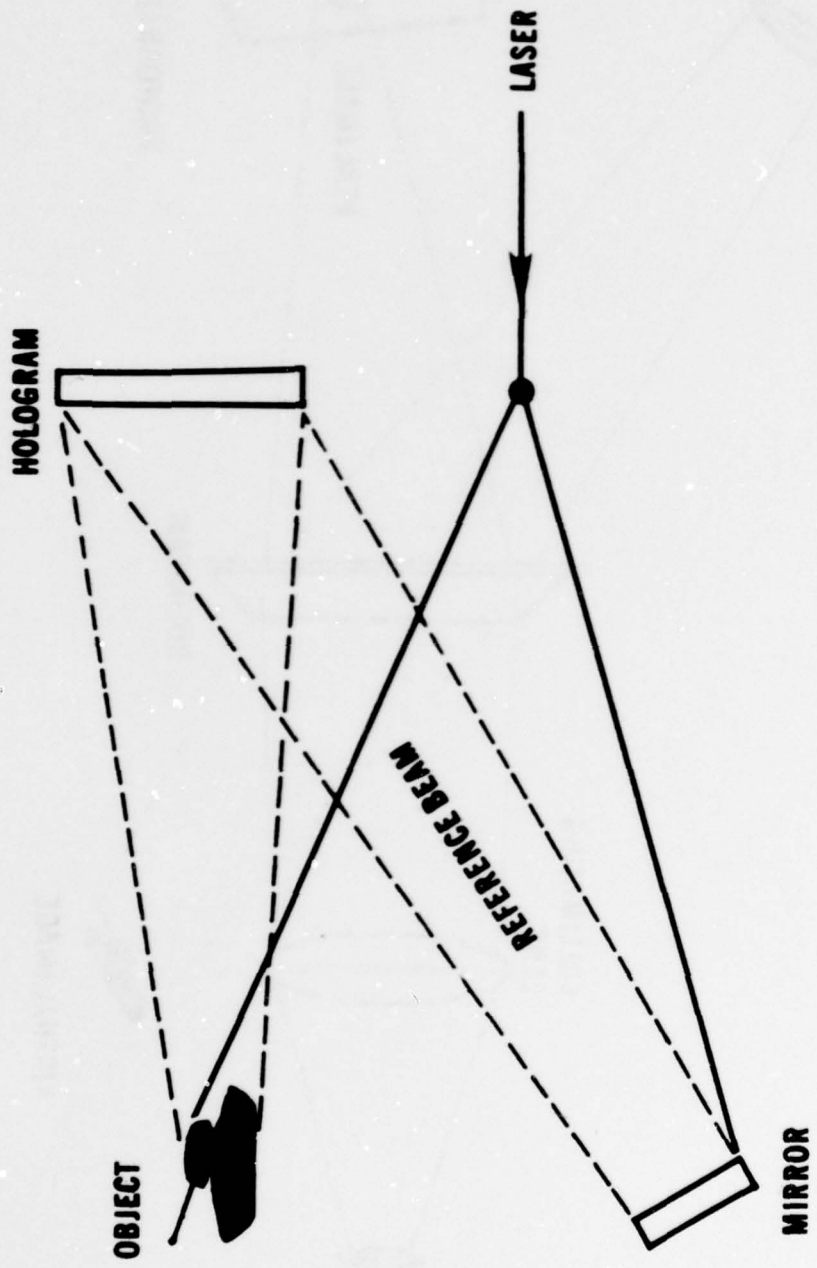

Figure 4. Holographic Recording of Three-Dimensional Object

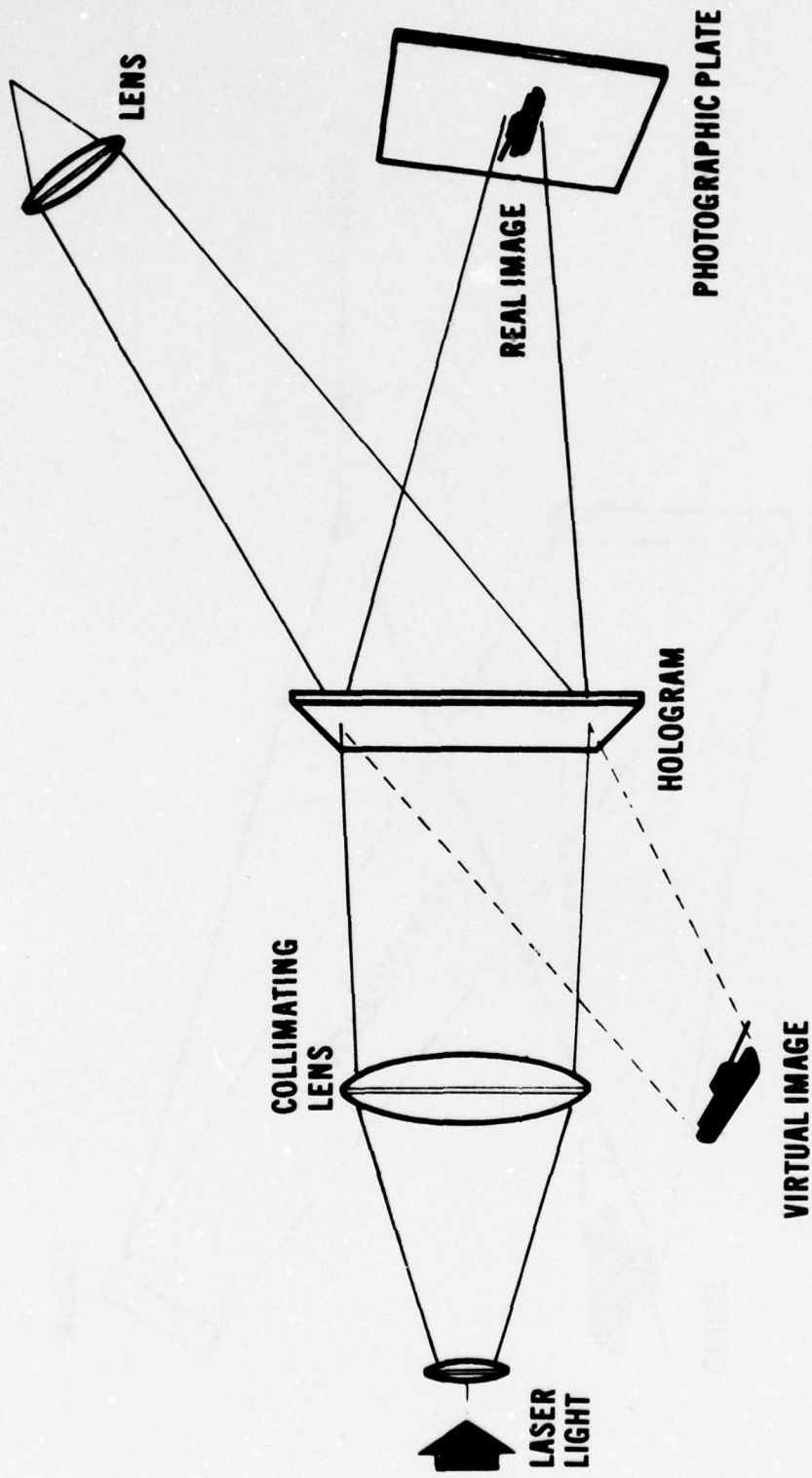

Figure 5. Reconstruction of Images from Hologram

introducing the off-axis reference beam, Leith and Upatnieks⁵ accomplished separation of the two images. This provided the initial technological breakthrough that enables practical applications of holography.

Bragg Diffraction. Another technique is available to the holographer to aid discrimination between real and virtual images. When a sinusoidal diffraction grating, a simple type of hologram, is optically thin (i.e. no thicker than a couple of wavelengths of light), it forms plus and minus diffraction orders, called +1 and -1, which correspond to the real and virtual images respectively. If the grating can be made thick, however, it channels most of the light into the +1 order. If the grating can be made greater than about 10 wavelengths thick, essentially all of the diffracted light goes into the +1 order and the resulting recording must be treated as a 3-D grating. For a thick hologram, the exposed regions form surfaces through the volume of the emulsion. Figure 6 shows a cross-section of a thick hologram where these surfaces are planes perpendicular to the emulsion surface. Notice that the reflected beam indicated

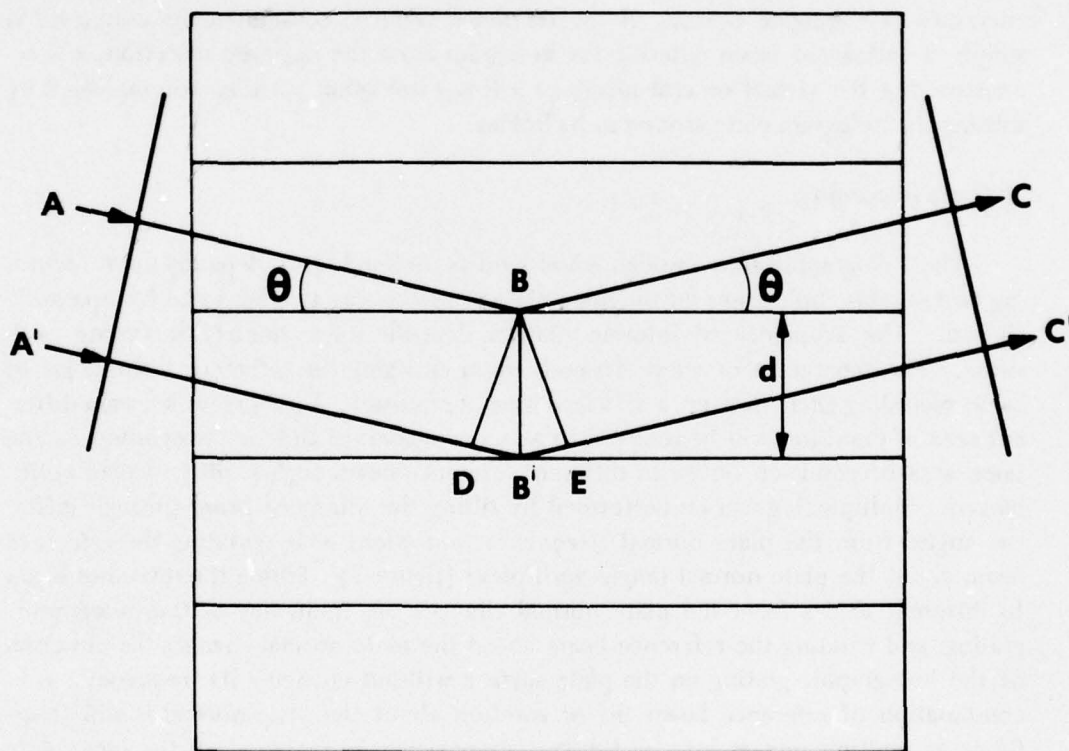

Figure 6. Diffraction of Light by a Thick Film Grating

⁵ E. N. Leith and J. Upatnieks, "Reconstructed Wavefronts and Communication Theory," *J. Opt. Soc. Amer.*, Vol. 52, 1962, p. 1123.

with primes must traverse an optical path greater than the top beam by the distance $D B' E$ which causes constructive interference between them at the proper angle θ .

An entering light ray is slightly reflected from each layer of silver grains, but since there is a large number of such layers, the reflection of a beam will be very great in total. When this effect is added to the necessary conditions of angle imposed by diffraction, as in the thin grating case, the result is that instead of the three beams that are formed by a thin grating as in figure 3, almost all of the illuminating light is reflected into the +1 diffraction order and the other two beams are suppressed. This effect is called *Bragg diffraction*, after the man who studied the phenomenon as it applies to X-ray diffraction in a crystal lattice.⁶ Most of the emulsions used in holography are thick enough to form Bragg gratings. Special techniques such as overexposure and underdevelopment must be used to produce thin holograms in these emulsions. A Bragg hologram can be made to display either its virtual or its real image by reconstructing it with a reconstruction beam equivalent to the original reference beam or with a beam that is exactly opposite to the reference beam in direction and wavefront curvature (a conjugate beam). If the reference beam is collimated, its conjugate is simply a collimated beam entering the hologram from the opposite direction, and reconstructing the virtual or real image of a Bragg hologram is easily accomplished by turning the hologram plate around in its holder.

Multiple Recording.

The holographic stereomodel, which will be defined later, depends upon recording two separate holograms on the same plate in such a way that they can be separately viewed. The avoidance of intermodulation depends upon linearly recording both views. The separation of views depends upon changing the reference beam angle or upon recording each view on a different area of emulsion. Views recorded on a different area of emulsion will be referred to as *space-separated* and views recorded on the same area of emulsion but with different reference beam angles will be called *multiplexed*. Multiplexing can be performed by tilting the reference beam through different angles from the plate normal (*frequency multiplex*) or by rotating the reference beam about the plate normal (*angle multiplex*) [figure 7]. Tilting the reference beam to different angles from the plate normal changes the frequency of the holographic grating, and rotating the reference beam about the plate normal changes the direction of the holographic grating on the plate surface without changing its frequency. Any combination of reference beam tilt or rotation about the plate normal is still classifiable as multiplexing as long as the two stereoviews are recorded on the same plate area.

⁶ W. L. Bragg, "The Diffraction of Short Electromagnetic Waves by a Crystal," *Proc. Cambridge Phil. Soc.* Vol. 17, 1912, p. 43.

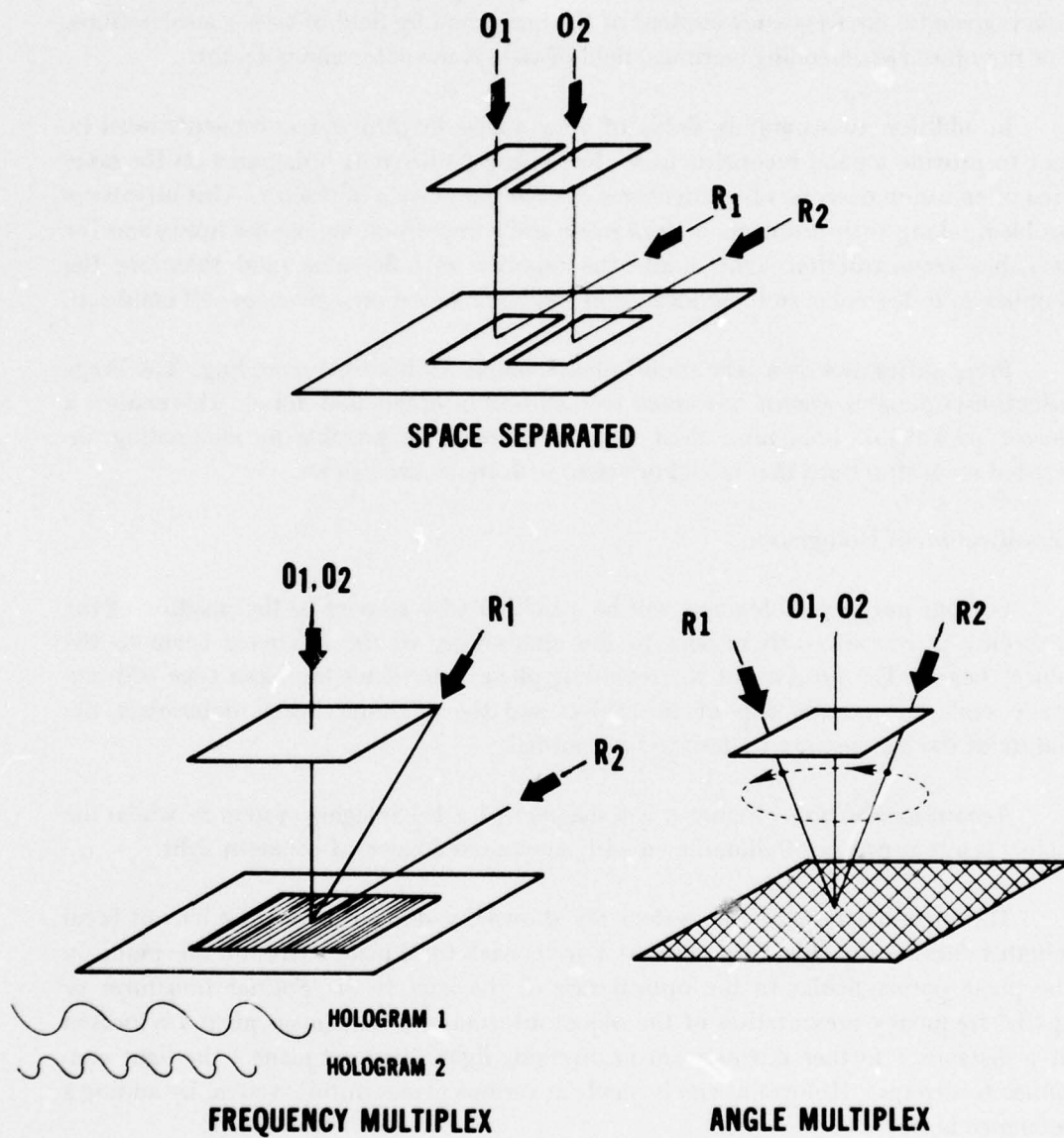

Figure 7. Three Methods of Recording More Than One Hologram on a Single Plate

Independent of the method of separation used, the problem is to completely separate the field of view of one reconstructed image from another. Thus there must be no overlap of right and left eye views when seen from the designed viewing distance. For frequency multiplexing, the minimum frequency difference to avoid intermodulation is given by the frequency content of the image and by field of view considerations. For the other two encoding methods, field of view is the determining factor.

In addition to separating fields of view, image brightness requirements must be met to provide a good reconstruction. Recording N different holograms on the same area of emulsion decreases the brightness of each image by a N^2 factor. This brightness problem, along with problems of film noise and competition among the holograms for available reconstruction light, limits the number of holograms (and therefore the number of holographic stereomodels) that can be recorded on a given area of emulsion.

Bragg diffraction is a very useful phenomenon for multiple recording. The Bragg effect discriminates against unwanted reconstruction orders and noise. This enables a denser packing of holograms than would otherwise be possible by eliminating unwanted reconstructions that would interfere with the desired views.

Classification of Holograms.

For our purposes holograms will be classified with respect to the position of the recording plane and with respect to the relationship of the reference beam to the object beam. The position of the recording plane determines the basic type of hologram while the relationship of the object and the reference beams determines the nature of the interference pattern to be recorded.

Recording Position. Figure 8 is a diagram of a 1:1 imaging system in which the object is a transparency O illuminated with a collimated beam of coherent light.

The marginal rays of the system are shown by dashed lines. The lens of focal length f focuses the light to a point at F in its back focal plane. Around this point, in the plane perpendicular to the optical axis of the lens, is the *Fourier transform* or spatial frequency presentation of the object information. The image plane I is located at a distance f further downstream in diverging light. Beyond plane I the light continues to diverge. Holograms can be made at various planes in this system, by adding a reference beam.

Holograms may be taken at planes A through E as shown in Figure 9.

Case A. A hologram recorded at a distance from any focal plane of the system is a *Fresnel* hologram. In reconstruction, this type of hologram produces an

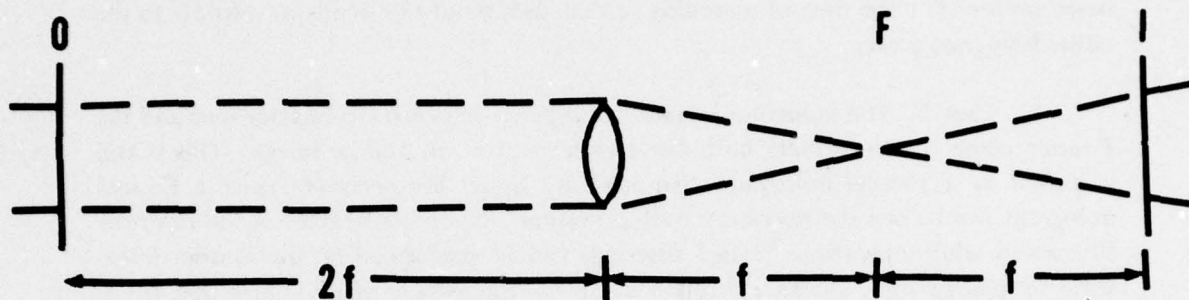

Figure 8. Imaging Geometry

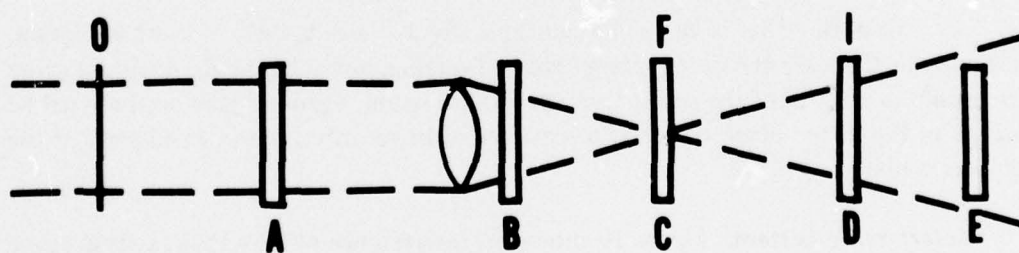

Figure 9. Representative Locations for Recording Holograms

image of 0 at the same distance from the hologram plate as the original object. To be able to view the object, a scatterer (ground glass) must be placed in the illuminating beam before 0 at the time of recording so that each point of 0 sends wavefronts to the entire hologram plate.

Case B. If a hologram is made in the space between the imaging lens and the Fourier plane it reconstructs both the Fourier transform and an image. This is still classified as a Fresnel hologram. No auxiliary optics are necessary since a Fresnel hologram can record the necessary optical system. The reconstructed scene can now be viewed while operations (called filtering) can be performed on the Fourier transform by placing light blocks and phase shifters in the Fourier plane. These operations change image characteristics and can be useful for photointerpretation, however speckle is a degrading factor which would probably be dominant over any improvements in the image due to filtering. Speckle will be discussed more fully in section III.

Case C. A hologram in the F plane is a *Fourier Transform hologram*. Since the image itself is not recorded and the hologram has no focusing power, an auxiliary lens is required to view an image upon reconstruction.

Case D. A *focused image hologram* is formed in the image plane. This type of hologram can be reconstructed with incoherent light since coherence requirements for hologram reconstruction are directly proportional to the distance between the hologram plate and the reconstructed image. This distance is zero for a focused-image hologram and incoherent light can be used for reconstruction without image quality degradation. White light from extended sources (sunlight, flashlight) works quite well for reconstruction.

Case E. This is the same conceptually as Case A, i.e. a Fresnel hologram, although in this case the illuminating light is diverging, not collimated. Again, in order to be able to view all of the image through this hologram, a ground glass screen must be placed in the image plane to act as a scatterer of image information to all parts of the hologram plate.

Interference Pattern. Figure 10 shows the interference pattern that exists in space when a plane wave and a spherical wave interfere. For this combination of object and reference beams, which is commonly used in making holographic stereomodels, the interference maxima form a pattern that is a family of paraboloids of revolution. In figure 10 these are seen in cross section as parabolas. Holograms can be made anywhere in this three-dimensional interference pattern, and four positions of interest are shown. The rectangles are a diagrammatic representation of the recording emulsion seen end-on. Spacing of the interference fringes and thickness of the emulsion have been exaggerated for ease of presentation. With visible light, the interference fringes

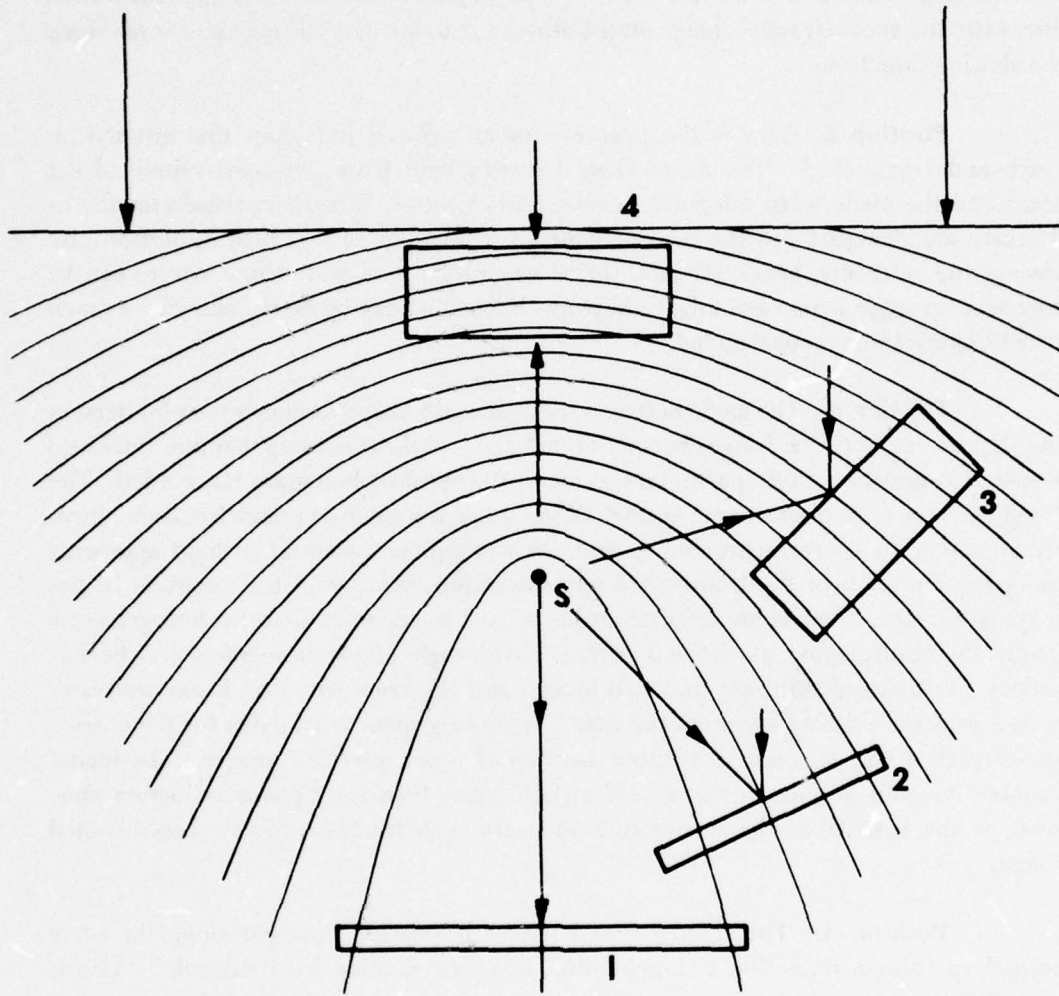

Figure 10. A Particular Cross Section of the Family of Maximum Intensity Contour Surfaces

have a spacing of less than 1 micron with the emulsion thickness about 10 microns.

Position 1. The mean direction of the plane wave and the reference wave are collinear. This is the *in-line* hologram first studied by Gabor in 1948.⁷ Although coherence requirements can be low for this type of hologram, the reference beam is in line with the reconstructed image, and both the real and virtual images also lie along the viewing direction.

Position 2. This is the position for an *off-axis* hologram first studied by Leigh and Upatnieks.⁸ The mean angle between light from the point source object beam and the plane wave reference beam is rather acute. Coherence requirements for this case are stringent and the recording medium must have a very high resolution. By placing the reference beam off-axis, the reconstructed real and virtual images can be separated in angle from each other and from the reconstruction beam, allowing a much cleaner image to be reconstructed.

Position 3. The angle between reference and object beams is near 90 degrees and the spacing between fringes becomes quite fine. If the recording medium thickness is several times the fringe spacing, a volume or Bragg-effect hologram is recorded. The Bragg effect acts to discriminate against all but a narrow angle of reconstruction, allowing an image to be reconstructed without any significant amount of light appearing along the direction of the transmitted reconstruction beam or in the direction of the conjugate image. This angle discrimination is used to separate different holograms by frequency multiplexing as defined earlier. Although planar holograms can be frequency multiplexed, the fact that two images and the reconstruction beam are transmitted into the viewing space means that less viewing space is available for the desired reconstructions to be seen in without overlap of other recorded images. The reconstructed image is brighter for Bragg-effect holograms than for a planar hologram since most of the light from the reconstruction beam is diffracted into the reconstructed image.

Position 4. The reference and object beams are opposed along the plate normal to form a reflection hologram that was first studied by Denisjuk.⁹ This is necessarily a volume hologram because the fringes here are nearly parallel to the emulsion surface. The exposed planes of silver act as a resonant reflection filter, which reflects a narrow range of wavelengths of light, transmitting or absorbing other wavelengths. As a result of this action, the hologram creates its own coherent light from

⁷ D. Gabor, "A New Microscopic Principle," *Nature*, Vol. 161, 1948, p. 777.

⁸ E. N. Leith and J. Upatnieks, "Reconstructed Wavefronts and Communication Theory," *J. Opt. Soc. Amer.*, Vol. 52, 1962, p. 1123.

⁹ Y. N. Denisjuk, "Photographic Reconstruction of the Optical Properties of an Object in Its Own Scattered Radiation Field," *Soviet Physics - Doklady*, Vol 7, 1962, p. 543.

white light and can be viewed in white light, although it must be recorded with coherent laser light.

III. HOLOGRAPHIC TERRAIN DISPLAYS

Terrain displays should provide an accurate stereoscopic reconstruction of the area displayed. Although for photogrammetric purposes this necessitates the removal of y parallax and correction of scale and rotations, the requirements for qualitative display are not as stringent. This section will concentrate on the construction and reconstruction of the hologram image for qualitative purposes. Photogrammetric requirements have been treated in detail in reports dealing with terrain measurement from holograms.

An important consideration in holographic terrain displays is that a hologram of terrain cannot be made directly from an airplane. The limiting factor is coherence length of the laser light that limits path differences between object and reference beams to a few meters at best. Therefore, indirect methods are used to record terrain images in a holographic format.

Early attempts to make holograms of distant scenes attempted to preserve the continuously changing perspective that gives such an illusion of reality in a Fresnel hologram of a nearby 3-D scene. Here the terms "near" and "far" refer to objects within and beyond the coherence length of the laser used to make the hologram. The methods varied in detail, but all made use of many fixed points of view with a small angular separation between holograms so that continuous perspective was approximated by a number of adjacent discontinuous views. Some experimenters used a camera with silver halide film to record these points of view. The resulting film strip of scenes was then used to build up a hologram in the laboratory.¹⁰ Others used a "fly's eye" array of lenses to directly record multiple views of a laser illuminated object.¹¹ The outstanding advantage of the film-strip methods is that available light may be used to record the scene. The encoding of the views into a hologram is then a laboratory exercise. In this way, stereoholograms may be made of the remotest objects that can be illuminated and photographed. The principle problems with this approach for achieving the illusion of continuous parallax are the difficulty of registration of the many views, and the large number of photos that must be taken of the scene. Additionally there is the difficulty of making each mini-hologram of the display diffract its view with the same brightness as the others.

¹⁰ J. T. McCrickerd and N. George, "Holographic Stereogram From Sequential Component Photographs," *Appl. Phys. Letters*, Vol. 12, No. 10, 1968.

¹¹ D. H. McMahon and H. J. Caulfield, "A Technique for Producing Wide-Angle Holographic Displays," *Appl. Opt.*, Vol. 9, No. 1, June 1970, p. 91.

Comparison with the ordinary photogrammetric stereo mapping camera leads to a simplification. In analogy with the fact that we only need two eyes to view the depth of objects, only two photographs of a scene, from different camera positions, are required to get a full sense of the relative distance of objects in the scene from the observer. This principle is easily utilized in holographic displays. Instead of using many points of view to encode the third dimension we only need two. The use of two points of view fixes perspective and does not give the continuously varying perspective that the use of many points of view does. The sacrifice of the illusion of continuous perspective is usually minor when compared with the advantages of simplicity gained by using a fixed point of view.

Continuous Perspective Model

There is a requirement for continuous perspective in some training situations. Although it requires a very large bandwidth in the emulsion (which will be discussed later), methods have been developed to display this type of hologram.

For certain training or command situations, a continuous perspective model may offer enough advantages to offset the difficulty of its manufacture. It is for this reason that details of these types of holograms will be explained. The rest of the report will then deal with stereoscopic or two-photograph terrain holograms, which will be called *holographic stereo-models*.

Common to the two methods to be described is the construction of a plaster model of the terrain of interest at the scale required. This is necessary to obtain continuous perspective within the coherence length of the laser used to make the hologram. The plaster model is then recorded by either the cylindrical film or the close proximity technique. An approximation to continuous perspective models is obtained with composite holograms constructed from intermediate photographs as mentioned earlier.

Cylindrical Film. This method uses a cylindrical film sheet large enough to fit around the model. In the usual configuration a point source of coherent light is then positioned above the film and the model as shown in figure 11. That part of the cone of light that falls directly on the film forms the reference beam R, as shown, and the part that is reflected from the model is the object beam O. When reconstructed by a coherent light point source P, the hologram will give a continuous perspective representation of the terrain model.

Close Proximity Technique. This method requires that the model be placed very close to a large flat hologram plate as shown in figure 12. If a reference beam can be introduced, the model may be viewed down through the hologram plate upon

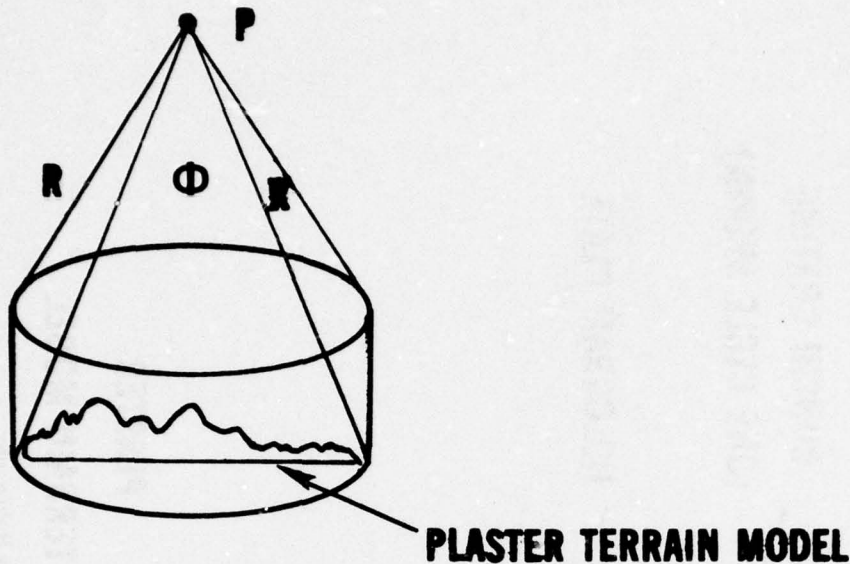

Figure 11. Cylindrical Film Hologram

reconstruction. The view will admit a wide range of perspectives because of the proximity of the model to the "window" of the hologram. McMahon and Caulfield¹² studied the difficulties associated with illuminating the model and introducing a reference beam, and they arrived at a solution using an alternately clear and opaque grating known as a Ronchi grating and a single illuminating laser beam. Figure 13 indicates the recording schematic at each clear and opaque Ronchi grating cycle.

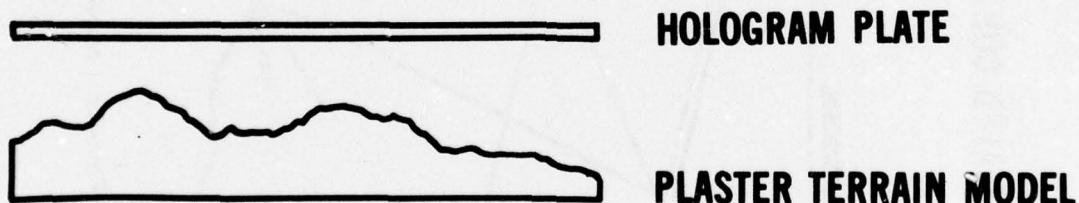

Figure 12. Close Proximity Holography

The hologram is formed in the part of the hologram plate that is shadowed by the opaque strips of the Ronchi grating. The reference beam is formed by partial reflection of the incident light from the back of the hologram plate, which is slightly tilted as shown in exaggeration. The unreflected portion of the illuminating beam then shines on the object, which scatters light to the hologram emulsion. This scattered light constitutes the object beam. Those areas of emulsion under the clear strips of the Ronchi grating are overexposed and take no part in the recording of the hologram.

¹² "A Technique for Producing Wide-Angle Holographic Displays," *Applied Optics*, Vol. 9, No. 1, June 1970, p. 91.

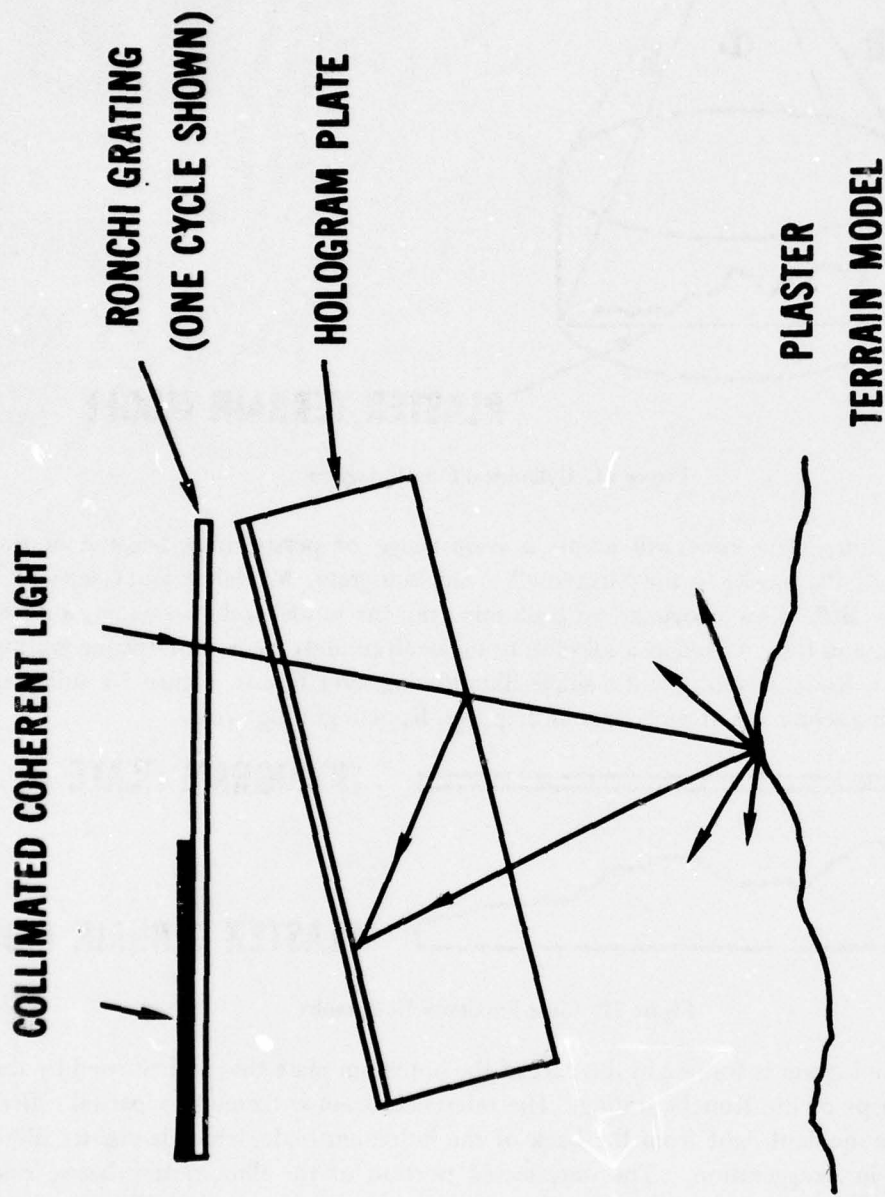

Figure 13. Recording Geometry for Close Proximity Holography

The Ronchi grating will be visible if it is too coarse and it will smear the image by diffraction if it is too fine; therefore there is some optimum grating frequency that is dependent on the depth of field desired. Bragg effects must be used to screen out the real image. For 649F emulsion, which is quite thick and therefore has a strong Bragg effect, the display can only be viewed in a cone angle of from 11° to 32° from the vertical. The Agfa 8E70 emulsion is thinner and can provide a better field of view of from 22° to 66° from the vertical. Bleaching is unsatisfactory because the wide range of frequencies recorded causes a large amount of scattering in a bleached emulsion. Despite its deficiencies, this method may be the best way to create a continuous parallax model for simultaneous viewing by several observers.

It should be noted that coherent light is a requirement for reconstructing this type of hologram (Fresnel) and this will produce speckle in the perceived model for either of the two methods explained above.

Composite Holograms. Another technique giving the illusion of continuously changing perspective is the encoding of many discontinuous points of view mentioned in the last section.¹³ Since film is a necessary intermediary, the hologram may be recorded in any of the configurations described in the Classification of Holograms section of this paper. An important consideration is the angular field of view of each mini hologram, which should be such that it will just fill the pupil of an observer at some standard viewing distance. For a typical light-adapted pupil of 3 mm and a viewing distance of 250 mm (distance of most distinct vision), this is approximately 0.7 degree. This rather close spacing allows the successive views to fade smoothly into one another since their discontinuity is smoothed by convolution with the eye aperture. Discontinuities that are annoying to the observer include overlap of the mini holograms and disparities of scale, brightness, and registration between adjacent mini holograms. The control of these problems is difficult because of the lack of a check during the process; i.e., the hologram plate is only developed after all exposures have been made, and corrections for the problems mentioned must be done after a series has been exposed, whereupon the entire series must be exposed again. With careful design of indexing and exposure apparatus, these problems should be manageable. A much more serious problem is the availability of closely spaced photographs of terrain that are needed to make these continuous parallax holograms.

The Holographic Stereomodel

A holographic stereomodel is defined for the purposes of this report as a holographic recording of a properly adjusted stereomodel. The concept of "model" has the photogrammetric meaning, that the resulting terrain display differs from the

¹³ R. J. Collier, C. B. Burkhardt, and L. H. Lin, *Optical Holography*, Academic Press, New York, 1971, Chapter 18.

actual terrain only in scale, other distortions having been removed by photogrammetric adjustment.

In the past there has been some confusion between the terms "holographic stereomodel" and "holographic stereogram." McCrickerd called the holographic stereogram ". . . a hologram synthesized from ordinary stereoscopic component photographs."¹⁴ This definition does not mention the removal of distortions. Kurtz precisely specified the holographic stereomodel as ". . . a virtual monochromatic holographic anaglyph in which the overlapping images are separately stored in a multiplexed hologram."¹⁵

This is too tightly defined since holographic displays of photogrammetric stereomodels do not need to be monochromatic, nor do they need to be encoded as a multiplexed hologram. Perhaps the term holographic stereogram should be reserved for photogrammetrically uncorrected displays, a usage consistent with McCrickerd's definition.

The discussion of methods for recording and using holographic stereomodels will follow the outline of the classes of holograms presented earlier. The order of discussion will be Fresnel holograms, Fourier transform holograms, and image plane holograms.

Fresnel Case. This is the most general type of hologram, where the recording is not made near an image plane of the object or near the light source. Its most significant characteristic is that laser light must be used to reconstruct the image as well as to record it. The depth of focus of a hologram depends on the coherence of light used to record and to reconstruct it. Images formed at some distance from the hologram plate therefore require reconstruction by highly coherent laser light. Laser light then produces the problem of subjective speckle, which is a function of the aperture through which the system is viewed. Although there are techniques for reducing speckle for a human observer, most of these methods depend on reducing the system resolution to less than an average speckle size, which reduces the resolution in the reconstructed image by the same amount. This loss of resolution could be severe and is usually unacceptable. For viewing by a human eye with about a 3- to 5-mm pupil, the speckle is quite severe and is an unacceptable condition. Electronic viewing of a hologram image through a TV system can alleviate this problem, because the lens aperture is much greater than an eye pupil and the speckle becomes so small it cannot be seen by a vidicon.¹⁶ Multiple reference beams can also be used to average out speckle.

¹⁴ J. T. McCrickerd, in abstract of *The Holographic Stereogram*, Scientific Report No. 10, Quantum Electronics Laboratory, California Institute of Technology, Pasadena, California (1969).

¹⁵ M. K. Kurtz, N. Balasubramanian, et al., *Study of Potential Application of Holographic Techniques to Mapping*, US Army Engineer Topographic Laboratories, Fort Belvoir, VA technical report No. ETL-CR-71-17, DDC No. AD 734327, p. 92.

¹⁶ *Ibid*, pp. 1-8.

Despite the speckle problem, this type of hologram was the first investigated for recording a holographic stereomodel. Kurtz¹⁷ gave a history of the holographic stereomodel and much of the following information is taken from his report. The earliest methods were similar in that they all recorded the light emitted by the eyepieces in a stereoscopic viewer. When the reconstruction beam is introduced, the scene may be viewed as if the observer were looking into a stereoscope illuminated by coherent light. These holograms were all in the category of Fresnel, space separated holographic stereomodels, and there is much to be said for them in terms of data compaction and ease of viewing. This approach has been neglected in subsequent work, probably because of eye relief problems and an unavoidable lack of flexibility in the viewing system, which cannot be adjusted for the observer's eyebase. The idea of recording the optical system needed to view the model as a part of the hologram is a good one and has been used in later generations of holographic stereomodels.

Kurtz addressed the problem of measuring terrain from a holographic stereomodel. That problem is outside the scope of this report, but a significant part of the work completed was concerned with the display. He decided to frequency multiplex his holograms to avoid eye relief and eyebase problems. This also allowed the use of auxiliary magnifying optics that could be inserted between the eye and the hologram plate owing to the large eye relief. Magnification is particularly useful in Fresnel holograms because the subjective speckle stays the same size, independent of magnification, and measurements can be performed more precisely under magnification. Since the holograms of the right and left views were not spatially separate on the hologram plate, some means had to be found for viewing the model. Kurtz used the idea of crossed polarizers where the right and left views were reconstructed with orthogonally polarized reconstruction beams and were then viewed through glasses having polarizers that were orthogonal from one eye to the other (figure 14). This is the same method as that used for 3-D movies.

Using separate reference beams for the right and left views also allows slight differential adjustment of the stereopairs to remove residual y-parallax. The limits within which adjustment can be accomplished have been defined.¹⁸ This type of adjustment would be necessary for measurement because emulsion creep and shrinkage would necessitate some model adjustment upon reconstruction. These problems are not serious in a display application where alignment only has to be sufficient for the stereo image to be perceived without eyestrain.

¹⁷ M. K. Kurtz, et. al., *Study of Potential Application of Holographic Techniques to Mapping* US Army Engr Topo Lab, Fort Belvoir, VA, ETL-CR-71-17, AD 734 327, pp. 1-80.

¹⁸ D. L. Gifford and E. M. Mikhail, *Study of the Characteristics of the Holographic Stereomodel for Application in Mensuration and Mapping*, US Army Engineer Topographic Laboratories, Fort Belvoir, VA ETL-CR-73-14.

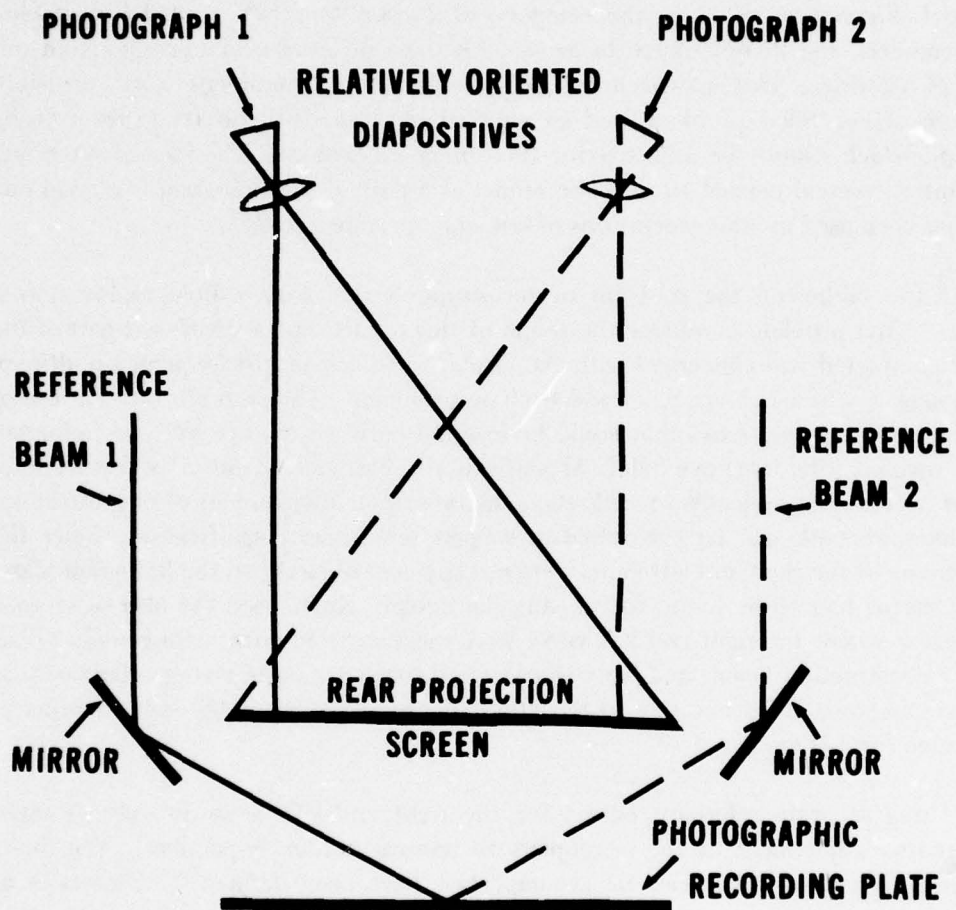

Figure 14. Recording and Reconstructing the Fresnel Holographic Stereomodel

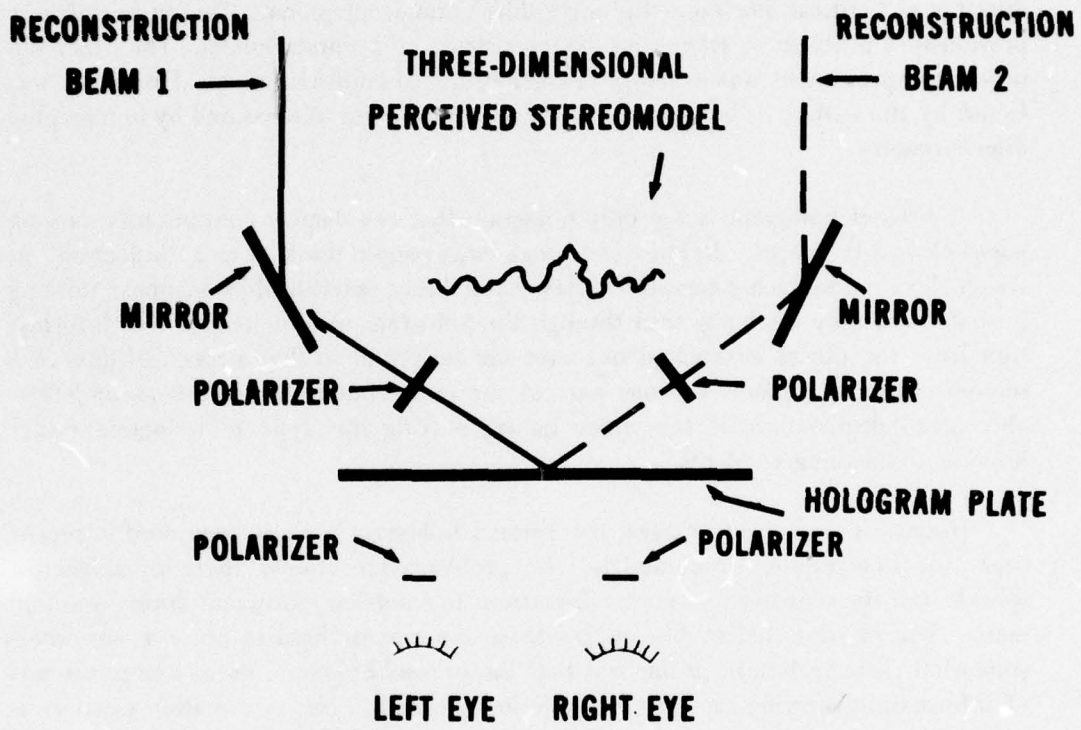

Figure 14. Recording and Reconstructing the Fresnel Holographic Stereomodel (cont'd)

In support of Kurtz' work on measurement of holographic stereograms, N. Balasubramanian and T. Kellie¹⁹ devised a method of making holograms that greatly reduced emulsion shrinkage by making a thin hologram on a thick emulsion. The technique includes deliberate over-exposure,²⁰ visual under-development, rapid washing after minimal fixing and rapid drying by wiping. The resulting hologram is formed on a thin surface layer of the available emulsion, which makes it a thin hologram as defined earlier. The thin hologram cannot separate real and virtual images by the Bragg effect, but it has some advantages. The angle at which the reference beam is introduced is not critical, nor does this angle shift upon development. This angle shift was previously a problem in attempting to reconstruct an accurate model. The other significant improvement was in image distortion due to emulsion creep. Distortion was found by the author to be only a few wavelengths of light as measured by holographic interferometry.

A Fresnel hologram is the only hologram that can display continuously varying perspective 3-D images. It is in fact what most people think of as a "hologram" in which dice, model racing cars, crown jewels, or other fanciful objects appear floating in space as if they are being seen through the hologram window (figure 5). Information from the object is smeared out over the hologram so that a speck of dust or a scratch does not degrade any one part of the image but rather causes an undetectably small degradation of the entire image, making this type of hologram rather immune to handling accidents.

Despite its many advantages, the Fresnel hologram has not been used in recent years for holographic stereomodels. Its problems are chiefly those of subjective speckle and the sensitivity of model distortions to emulsion movement during development. Use of silver halide film makes these movements hard to prevent. Another, somewhat more technical, problem is that the Fresnel hologram needs a large amount of information carrying capacity in the hologram plate. This information capacity is expressed as a space-bandwidth product (SBP), which is the product of the hologram plate resolution per unit area times the area of the plate. It represents the total "channel capacity" of the plate. Although the large SBP is necessary for accurate reconstruction, it is also poorly used by the hologram with much of it being wasted. However, this fact is usually not significant because the emulsions used for holography have sufficient resolution so that information storage is not a problem, even in the rather inefficient Fresnel hologram, which is approximately two times less efficient than the other holograms being considered.²¹

¹⁹ T. F. Kellie and W. H. Stevenson, *Study of the Characteristics of the Holographic Stereomodel for Application in Mensuration and Mapping*, US Army Engineer Topographic Laboratories, Fort Belvoir, VA, ETL-CR-73-14, Part II, Appendix B.

²⁰ G. H. Glaser and E. M. Mikhail, *Study of Potential Application of Holographic Techniques to Mapping*, US Army Engineer Topographic Laboratories, Fort Belvoir, VA ETL-CR-70-8, AD 718 084, p. 121.

²¹ A. W. Lohmann, *The Space-Bandwidth Product Applied to Spatial Filtering and to Holography*, IBM San Jose Research Laboratory Research Paper No. RJ-438, 9 May 1967.

Another problem in the Fresnel case is the presence of intermodulation noise. This noise arises from interference between different points of the object and is only possible in the Fresnel case where each object point is recorded over the entire hologram plate. Its effect is to cause a hazy background light to appear in the vicinity of the reference beam. To avoid mixing this light with the image, a larger reference beam angle must be used than is necessary to reproduce the information in the hologram. This means that a larger SBP is necessary on the hologram plate to record the finer interference grating because of the larger angle between the reference and the object beams. Since the Fresnel hologram is already at a disadvantage because of its large SBP requirements, this presents an additional disadvantage.

A type of Fresnel hologram with potentially interesting properties is the Lippmann-Bragg or reflection type. The Lippmann effect is seen as the object and reference beams enter approximately normal to the hologram plate from opposite sides. The Bragg planes are then formed nearly parallel to the plate. In addition to carrying the hologram information, this layering of Bragg planes acts as a resonant reflector that will selectively reflect only a narrow band of light wavelengths. The result is that the Lippmann-Bragg hologram makes its own coherent light from incident white light and a lens is not needed to view the hologram.²² Unfortunately, spatial coherence (i.e., a point light source) as well as temporal coherence (a narrow range of wavelengths) is needed to view a Fresnel hologram. Of these two requisites, the Lippmann-Bragg emulsion provides only temporal coherence. The effect of having a light source that is not a fine point is that the detail in the hologram will be destroyed by the width of the source, i.e., the larger the source, the less image detail will be seen. This rules out viewing the Fresnel case of a Lippmann-Bragg hologram by a flashlight or by sunlight, and thereby removes its usefulness for field conditions. The Lippmann-Bragg type of hologram can be used for any of the geometries normally used for holography, since it depends on the reference beam angle and not on the type of hologram being recorded (Fresnel, focused image or Fourier transform). Its most promising use is with the focused image hologram, and it will be discussed in that section.

Fourier Transform Hologram. A short discussion of information requirements in holography is useful at this point. From an information standpoint, the most efficient method of recording a flat scene is simple imaging by a lens or contact printing. If we call this amount of information N , we can see how holography compares with imaging. The most efficient holograms for information storage are the Fourier transform and focused image types. For these holograms we can consider the recording to be a process of encoding the object beam signal by modulating a carrier wave, as in radio transmission of audio information. This modulation process increases the bandwidth

²² G. Stroke and A. Labeyrie, "White Light Reconstruction of Holographic Images Using the Lippmann-Bragg Diffraction Effect," *Bell System Tech. Journal*, Vol. 45, 1966, p. 659.

by a factor of three.²³ In addition to the information encoding requirements, a carrier frequency high enough to separate the fields of view of the hologram images must be used. This is physically realized by the angle between the reference and object beams that generate the interferometric fringes that serve as spatial information carriers. The field of view problem is dominant for terrain holographic stereomodels and carrier frequencies can become quite large for this reason alone. If an offset angle of 30° is needed for image separation (a typical figure), this corresponds to a carrier frequency of approximately 1,000 cycles per mm even though image information of only 10 cycles per mm is sufficient to appear perfectly sharp to a normal eye. The information density of the holographic stereomodel is therefore 100 N when the contact print would only require N points to be recorded. Because of the focusing function recorded in a Fresnel hologram, its information efficiency is even worse than for the Fourier transform and focused image types. Since large amounts of information must be recorded, the media on which holographic stereomodels can be recorded is limited to those having the highest resolution.

Of the two most efficient types of holograms for information storage the Fourier transform (FT) and the focused image types, we will consider the FT first. For the FT hologram, the transforming property of a lens is used to alter the disposition of information in a flat object like a photograph. The information is changed from the image mode, where each image point is spatially located on the photography, to the transformed mode where spatial frequency information is spatially located on the Fourier transform plane. The transformed information exists in a polar coordinate r, θ form with zero spatial frequency at 0, 0. Spatial frequency then increases with r , and the direction in which this spatial frequency is found on the input photography is encoded in θ . By operating on the Fourier transform with a lens, we can return to an image again. If a reference beam is added at the Fourier plane, an FT hologram may be recorded. When reconstructed, it may be re-transformed into an image by a lens. The FT hologram has a relative immunity to scratches and blemishes, since local image information is delocalized in a Fourier transform.

The FT hologram has a number of disadvantages for display applications: The image encoded in an FT hologram cannot be viewed without an auxiliary optical system. Laser light must be used to reconstruct the image, which causes the usual problems with speckle in the reconstruction. It is very difficult to record an FT hologram because of great differences in the energy distribution from one part of a Fourier transform to another. The center of the transform pattern represents average transmittance of the photograph. This region is typically thousands of times brighter than peripheral areas of the transform that contain the high spatial frequencies of image detail information. The recording of such a wide range of energies is well beyond the capabilities of

²³ E. N. Leith, "Resolution Requirements for Holography," *Optical Processing Fundamentals with Applications*, Univ. of Michigan Engineering Summer Conference, 1971, Chapter 4.3.

available sensitive media. This problem is usually solved by defocusing or recording slightly outside the Fourier plane. Although this does reduce the range of energies to be recorded, the resulting hologram is no longer a Fourier transform hologram but is a Fresnel type. Another approach to the problem would be to filter out the average transmittance of the photography by overexposing the center of the Fourier plane. This is called d.c. blocking in analogy with electrical engineering practice, although we are blocking the zero spatial frequency, not the zero electrical frequency, (i.e., the d.c.). The resulting recorded image retains only high frequency information and appears as if it has been spatially differentiated. It is therefore not very suitable for display.

The most promising use of Fourier transform techniques, including holography, is in information processing and not in display. For this reason, there has not been much investigation of the use of Fourier transform holograms as display media.²⁴

Focused Image. The focused image hologram has a combination of properties that makes it the most attractive type for many display applications. This hologram consists of an image sampled (i.e., multiplied by) a cosine grating formed by introducing a reference. From the sampling theorem, the grating must have twice the frequency of the highest frequency information present in the image, which condition fixes the necessary reference beam angle.²⁵ Coherence requirements on the reconstruction of a hologram are determined by the distance between the diffracting grating in the hologram and the location of the real or virtual image reconstructed. Since the focused image hologram has no distance at all between the hologram plate and the image, we find that the coherence requirements are zero, or at least small in practice. This means that white light can be used to reconstruct the image. Although the real and virtual images are located in the same space, it is advantageous to view the hologram in the real image mode because of the field of view advantages gained by looking at the terrain image²⁶ (figure 15). Although the lens image will be blurred if white light is used to reconstruct the hologram, it will still serve adequately as an aperture through which the scene can be viewed. The hologram is constructed so that the lens images for the right and left views are located in space at a distance of 25 cm from the hologram plate (the distance of most distinct vision)²⁷ with a separation of about 65 mm center-to-center, which corresponds to an average eyebase. The lens images are made large enough in reconstruction so that they are approximately tangent to each

²⁴ F. Bestenreiner, V. Greis, and W. Weiershausen, "Alphanumeric Storage Capacity of a Defocused Fourier Hologram and a Fourier Hologram Matrix," *Photogr. Sci. Eng.*, Vol. 16, No. 1, 1972.

²⁵ E. N. Leith, "Resolution Requirements for Holography," *Optical Processing Fundamentals with Applications*, Univ. of Michigan Engineering Summer Conference, 1971, Chapter 4.3.

²⁶ T. F. Kellie and W. H. Stevenson, *Study of the Characteristics of the Holographic Stereomodel for Application in Mensuration and Mapping*, Part II, U.S. Army Engineer Topographic Laboratories, Fort Belvoir, VA., ETL-CR-73-14, AD 779 180, p. 44.

²⁷ *Ibid.*, chapter 4.

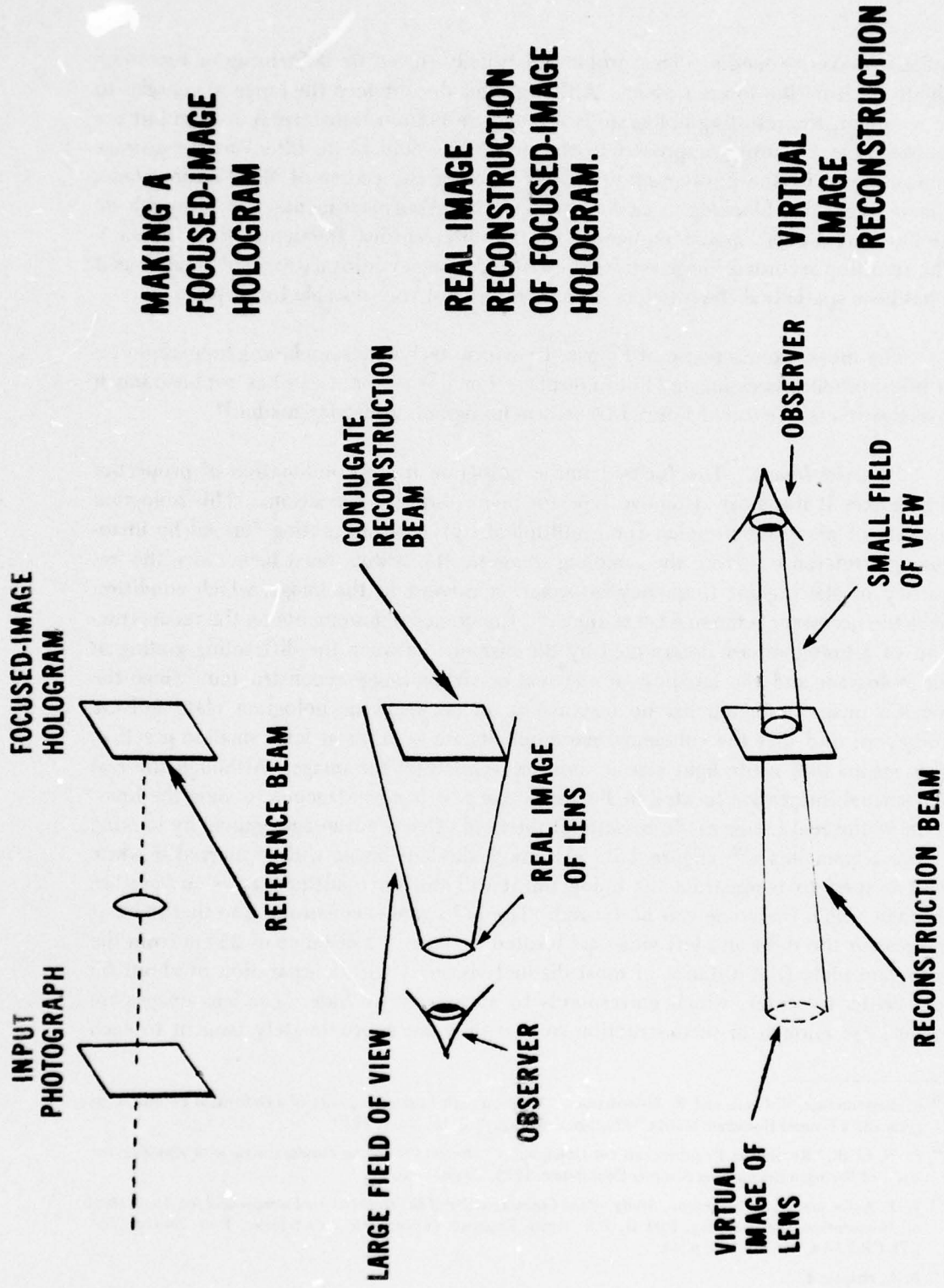

Figure 15. The Field of View Effect of Real Versus Virtual Image Reconstruction of Focused-Image Holograms

other. This gives a large window through which the model can be viewed. This is desirable to accommodate a range of eyebases and to avoid the necessity of accurate head positioning for the observer. The reconstructed lens windows are larger than the original imaging lenses owing to several effects that must be considered when the hologram is being made. There is blurring of the lens images due to the separation of the lenses from the focal plane where the hologram is recorded. This defocusing is dependent upon the spatial and temporal coherence of the reconstruction source and the distance of the lens images from the hologram plate. Defocusing depending on the size of the source (spatial coherence) causes an increase in the size of the lens images that is the same as the source size; i.e., if the lens has a 2-inch diameter and the light source has a 1-inch diameter, then the lens image will have a 3-inch diameter. This effect acts equally in all directions. Because of temporal incoherence of the light source blurring only acts in a direction perpendicular to the hologram grating; so it is a *one-dimensional blurring*. This is due to the dispersion of the hologram grating, which diffracts red light more than blue light and spreads a white light source out into a spectrum. Since the observer's pupil is rather small, only a narrow band of frequencies of this dispersed light can be seen at a viewing position and the image will appear colored, the color depending on where the observer places his eye²⁸ (figure 16). The range of frequencies intercepted by the observer's eye is large enough (and the size of the source is also large enough) that no speckle is evident to the observer when white light reconstruction is used. These are the two greatest advantages of focused image holography: An extensive white-light source can be used to reconstruct the hologram, and there is no speckle in the reconstruction. Although the colored image is somewhat bothersome, viewing in green light does not seem unnatural.

In constructing a focused image holographic stereomodel, we have been limited in practice to space-separation of the right and left views because of the large amount of the linear transmittance region of the film that is used up by each view. Although multiplexed, focused-image holographic stereomodels have been made on dichromated gelatine, which has a very long linear range for diffraction versus exposure,²⁹ the difficulties attendant upon multiplexing are generally too great to consider it seriously in the focused-image case. This problem can be overcome, however, if carrier frequency photography is used.

Carrier Frequency Photography. Carrier frequency photography (CFP) is not a holographic technique for storage and retrieval of photographic information, but it is similar enough to focused-image holography to warrant discussion here. If a photograph is multiplied by a grating whose lowest spatial frequency component (i.e., the

²⁸ G. B. Brandt, "Image Plane Holography," *Applied Optics*, Vol. 8, No. 7, July 1969, pp. 1421-1429.

²⁹ J. T. McCrickard and G. H. Glaser, *Stereoscopic Terrain Display for Measurement Application*, Northrop Corporation, U.S. Army Engineer Topographic Laboratories, Fort Belvoir, VA., Report No. AD A008 085, December 1974, p. 49.

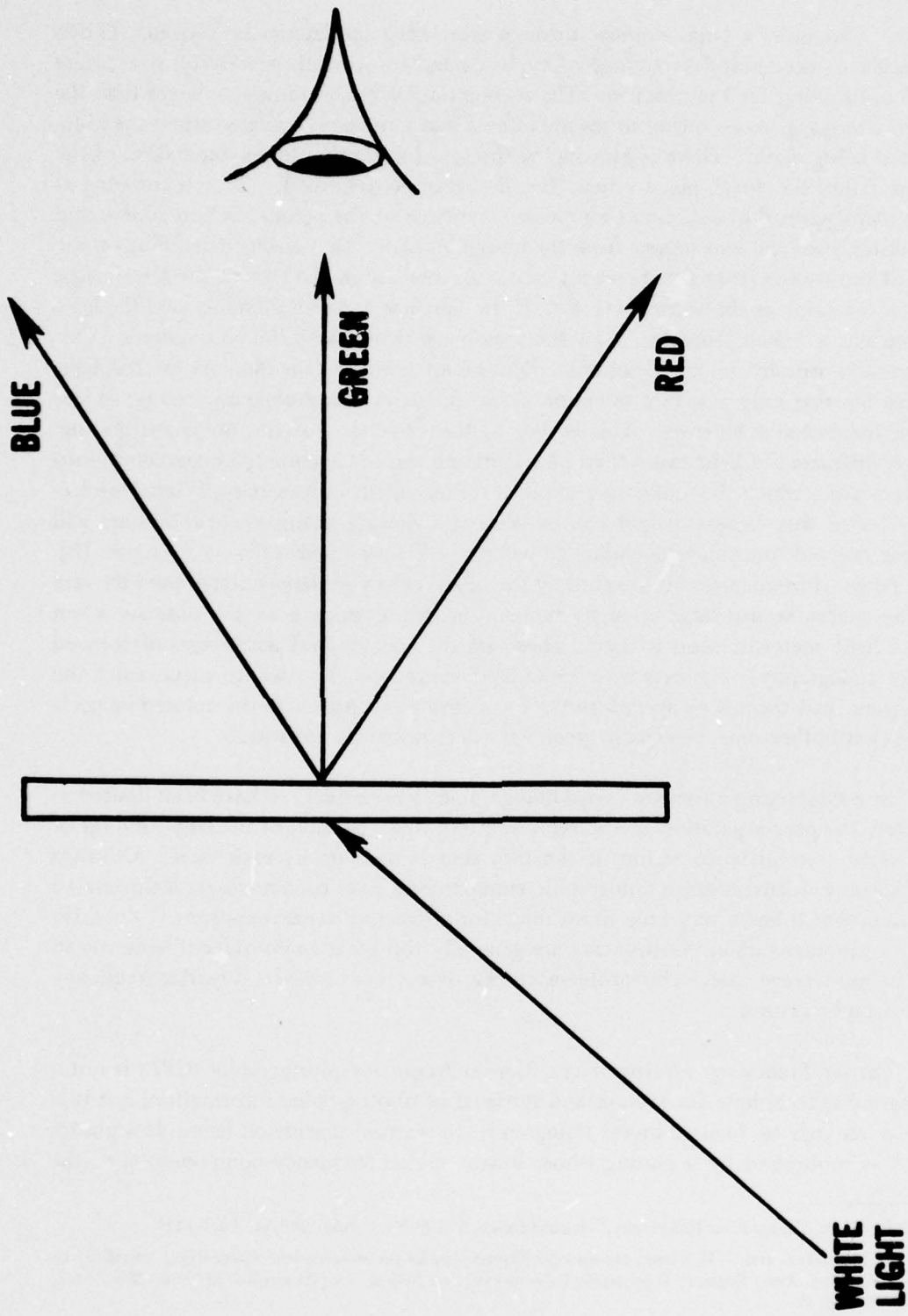

Figure 16. Dispersion of White Light from a Focused-Image Hologram

fundamental) is at least three times the highest spatial frequency present in the image, the condition is exactly analogous to an AM radio signal in which the information to be transmitted is carried on a sine wave. In analogy to a hologram, the +1 and -1 diffraction orders of the carrier grating can be reconstructed. These diffraction orders do not carry any phase information from the image beam, as they do in Fresnel holography, but merely act to diffract the illuminating light beam that is amplitude-modulated by the image.

Carrier frequency photography can be thought of as a special case of focused-image holography in which the reference and object beams are identical, except for the angle between them, and both carry the same image information. The result of amplitude modulating an image on a cosine grating is to multiply the two together. Therefore, no phase information is retained in the image wavefront seen in the first order. This does not affect the appearance of the image as seen by the observer; but in this case the blurred real image of the lens, which is used as a viewing aperture for the focused-image case, cannot be reconstructed because a lens was not used in the recording. This means that some field lens must be provided to allow the observer to see the whole scene. This can be done by using a large external lens or it can be built-in to the CFP by using a parabolic fringe pattern as the carrier frequency. A parabolic grating will focus collimated, coherent light to a point, and the grating will be formed by interfering a collimated laser beam with a spherical reference beam as shown in figure 5.

A spherical reference beam is easily created by passing a laser beam through a microscope objective with a pinhole at its focus. This combination is called a spatial filter and is widely used in coherent optical systems. If the spatial filter is placed 25 cm from the CFP plate, the conditions for best viewing are fulfilled. To create a stereomodel, the terrain stereopair is recorded with the spatial filter moved 65 mm sideways between recordings. The positions of the two pinhole images in space then form apertures through which the right and left images can be viewed (figure 17). For collimated, coherent light, these apertures are small points of light and are not suitable for viewing through; but if a distributed white light source is used for viewing, the apertures are expanded to a usable size, as was explained for the focused image holographic stereomodel.

There are several advantages of the CFP stereomodel when compared to the focused image holographic stereomodel. The most significant advantage is that less of the film linear range is used up by each exposure owing to lack of a bias term. This enables the stereomodel to be recorded by multiplexing on silver halide film, and this in turn enables the stereomodel to be viewed without auxiliary optics. Another advantage is that coherent light need not be used in making the CFP. There are two methods of making the exposure without coherent light. Both methods require that a transparency of the desired carrier grating be available. In one method the grating is

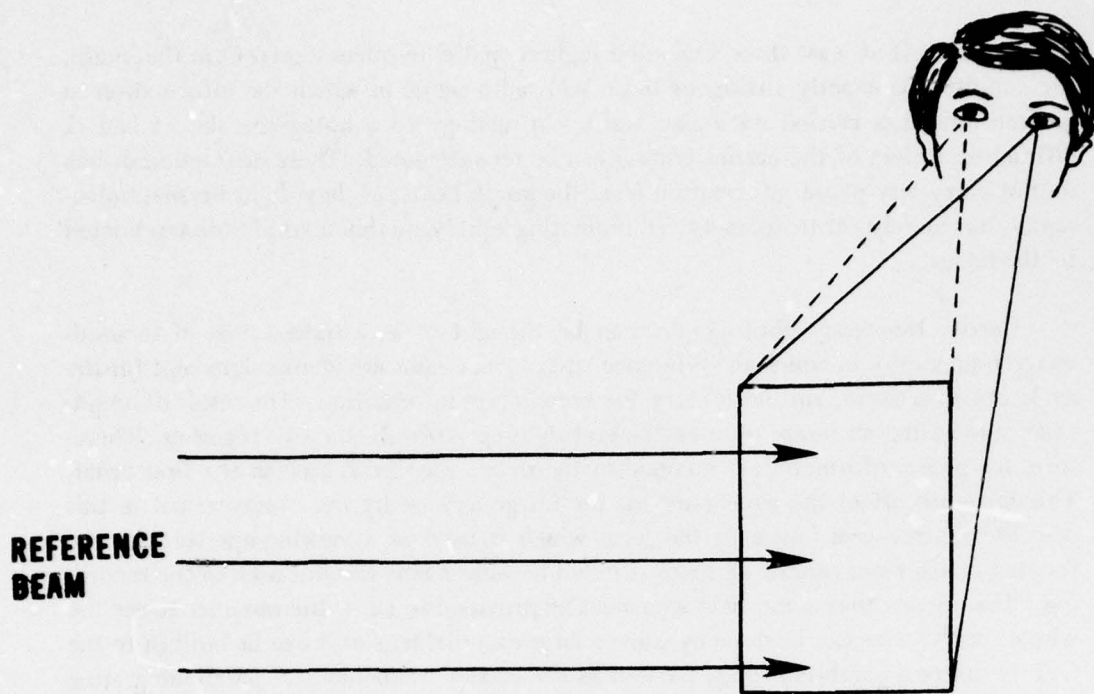

Figure 17. Holographic Stereomodel Viewing Apertures Created Through the Use of Spherical Reference Beams

contact printed on the CFP plate, then an image is projected or contact printed over the grating image. A second method is to project or contact print the grating and the image at the same time. This is a better method because it does not bias the film. In either case, the film then records the encoded image, which can be reconstructed as described above.

If the reconstruction light source is at a finite distance, the viewing apertures through which the holographic stereomodel is seen will move away from the CFP plate in accordance with the lens law, which states that the focal length of the lens (actually a zone plate formed by the sampling grating) is equal to the distance that the point source was from the CFP plate to begin with. The lens law is:

$$\frac{1}{\text{focal length}} = \frac{1}{\text{object distance}} + \frac{1}{\text{image distance}}$$

If the distance of the reconstruction light source from the CFP plate is the object distance, then the new position of the reconstructed viewing apertures will be the image distance. For a numerical example, if the focal length is 25 cm and the object

distance is 100 cm, then the equation will be

$$\frac{1}{25} = \frac{1}{100} + \frac{1}{X}$$
$$\frac{1}{X} = \frac{1}{25} - \frac{1}{100} = 0.03$$
$$X = 33 \frac{1}{3} \text{ cm}$$

So the viewing apertures have been moved away from the CFP plate by 33 1/3 cm. If the 25-cm distance of most distinct vision is to be preserved in reconstruction, the distance of the reconstruction illumination source from the plate must be taken into account.

Stereomodels of CFP have been made at ETL by contact printing transparencies onto a high resolution plate. To create the carrier grating, two coherent beams of light were used to illuminate the contacted object film and plate (figure 18). The grating was formed in space by the interference between these two beams. One of the beams was spherical and the other was collimated to encode a focusing function into the hologram for ease of viewing. The position of the point source was then shifted for the second exposure to get a proper eyebase for the observer. The model was reconstructed with a diffuse illuminator (figure 19).

Although it was possible to record a multiplexed stereomodel on silver halide film by this means, the contrast in the resulting model was low because of the limited linear range available on high resolution plates (Kodak 120-02 holographic recording plates were used); in addition, the proper exposure was very critical. Aligning the right and left views is difficult in a contact printing situation where slight misalignment of the object films causes artificial tilts in the reconstructed model. These tilts do not become apparent until after the plate has been developed, and corrections are practically impossible. For this reason, it would probably be best to create the CFP stereomodel by using a projection system that can be carefully adjusted to form a proper model. The carrier frequency would then be encoded onto the plate by projecting the terrain views through a carrier grating function in contact with the plate. This is the opposite of the method that was tried, where the terrain information was contact printed by a projected grating. However, these two methods are optically equivalent.

The recording could also be improved by using a nonsilver recording medium with a long linear range. Dichromated gelatine or photopolymer processes might be useful here. It should be mentioned that even if the recording of the right and left views of a multiplexed focused-image hologram or CFP are perfectly linear, there are competition

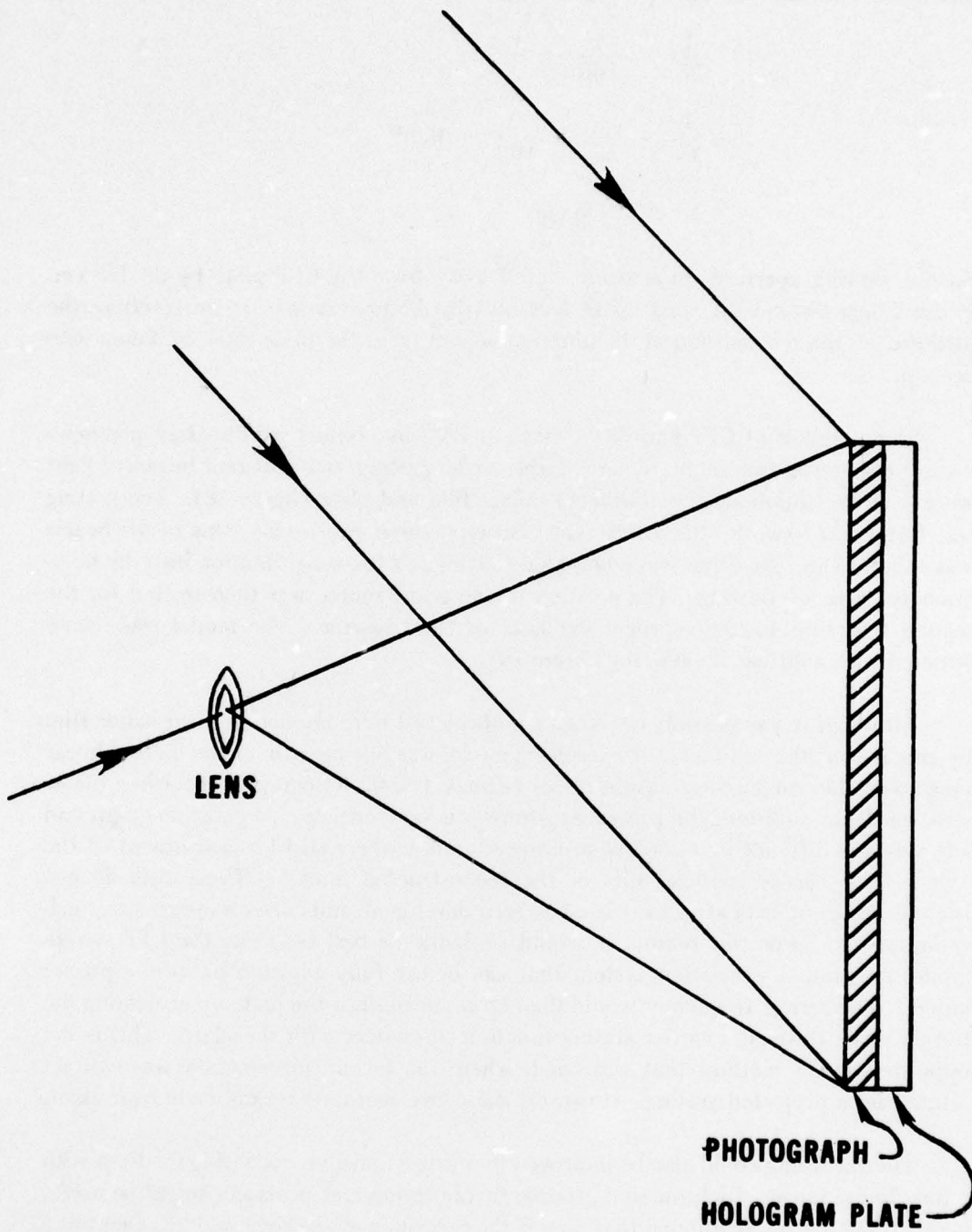

Figure 18. CFP Made by Contact Printing

DIFFUSE WHITE LIGHT

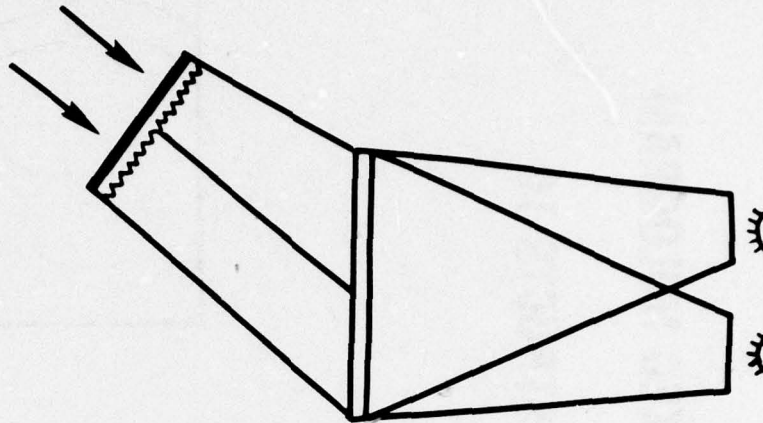

Figure 19. Illumination by a Diffuse Light Source

phenomena that affect the intensity of the viewed model.³⁰ If a light part of one view falls on a dark part of the other view on the plate surface, the light part will diffract a large part of the illuminating light into its view, leaving less light to form the other view. The result of this light loss is a ghost image on the darker area, since in effect it has less light available to illuminate it in the area where the bright part of the other view has diffracted the light away (figure 20).

This ghost image is not a result of a nonlinear process but is inherent in angle-multiplexed stereomodels, which are forced to compete for the available light. This effect can be avoided by encoding the views as Bragg gratings that use two separate reconstruction light sources, or by space separating the views. The first option would rule out viewing the display by sunlight or a flashlight, and the second option would require an auxiliary optical system to view the model.

The carrier frequency modulation depth is greatest where the largest amount of light falls on the recording plate. The most light is diffracted where the carrier grating is most deeply modulated. This means that bright parts of the object will appear bright in the image, and vice versa. Like holography, CFP does not reverse the polarity of the image if the diffracted image is viewed. For amplitude recording media such as unbleached silver halide film, a reversed image is also available in the zero order that can be thought of as an ordinary photographic contact print. Techniques have been developed for reversal of the diffracted images, when this is necessary, by using nega-

³⁰ J. T. McCrickard and G. H. Glaser, Stereoscopic Terrain Display for Measurement Applications, Northrop Corporation, U.S. Army Engineer Topographic Laboratories, Fort Belvoir, VA, Report No. ETL-0002, AD A008 085, December 1974, p. 44.

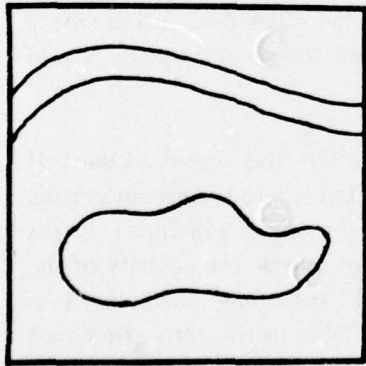

**MULTIPLIED HOLOGRAM
RECONSTRUCTS TO**



LEFT VIEW

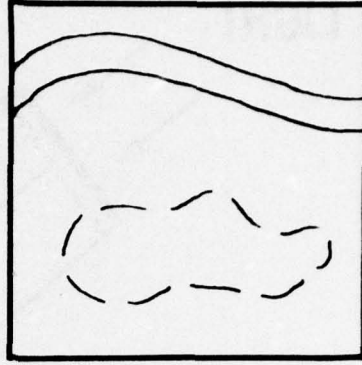
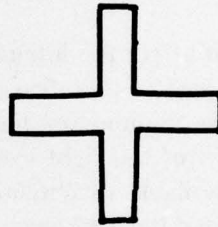

RIGHT VIEW

Figure 20. Competition Effects Between Bright and Dark Features.

tive film images as objects for the CFP.³¹

IV. OTHER USEFUL TECHNIQUES

Amplitude and Phase Encoding.

When exposed to light, silver halide emulsions become dark. Since the human eye sees light intensity differences in a logarithmic fashion, the film characteristics are usually stated in the form of a curve of density versus log exposure, or a D-log E curve. For holography, we are interested in the transmittance of the film, not the density.³² Transmittance is related to density by $D = \log 1/T$. A plot of transmittance versus exposure shows the region of exposure over which transmittance will be approximately linear. This region is usually much narrower than the linear part of the D-log E curve. This presents an important limitation when it is desirable to record a high contrast focused-image hologram, especially for the multiplexed holographic stereomodel, since the lack of linear range means it is difficult or even impossible to record the whole image linearly in transmittance. Nonlinear recording affects contrast and gray tone rendition in the recorded image and may even cause contrast reversal.³³ A method of obtaining maximum linear transmittance from a hologram is to copy to a D-log E slope (γ) of -2. The relation between transmittance and exposure is given by $T = E^{-\gamma}$. If $\gamma = -2$, then $T = E^2$ gives the intensity transmittance. Amplitude transmittance is obtained by taking the square root of both sides of the equation, giving the linear amplitude transmittance, $T_a = E$.

With ordinary film this means a two-step process in which the initial hologram has to be copied to effectively get a negative gamma. If the D-log E slope is -2, then the linear range of the T-E curve will be as long as that of the D-log E curve — a great improvement. Kodak has announced a holographic reversal film that processes directly to a gamma of -2.³⁴ This might help to solve the problem of making angle-encoded, focused-image holographic stereomodels.

Another way of recording holograms that permits a long linear range is the use of phase-only recording media. Phase media do not undergo a transmittance change when exposed. They either develop a change in thickness or in index of refraction that is proportional to exposure. These changes act to modulate the phase of an illuminating

³¹ O. Bryngdahl, "Image Polarity in Carrier-Frequency Photography," *Applied Optics*, Vol. 60, December 1970, p. 1698.

³² R. J. Collier, C. B. Burkhardt, and L. H. Lin, *Optical Holography*, Academic Press, New York, p. 265ff, 1971.

³³ J. W. Goodman, *Introduction to Fourier Optics*, McGraw-Hill Book Company, San Francisco, p. 268, 1968.

³⁴ R. D. Anwyl, "Storage Materials for Laser Recording," Presented at Society of Photo-Optical Instrumentation Engineers Meeting on Laser Recording (21 August 1974), published in *SPIE*, Vol. 53, p. 15.

52

wave, and a hologram can be recorded and reconstructed by this phase modulation. A hologram recorded on a phase medium can be reconstructed with high efficiency, since light energy is not absorbed in the phase medium to a large degree, i.e., the transmittance of these media is always large. Phase hologram plates look clear when observed in diffuse light, but they can diffract light with unique efficiency. For a thin hologram without Bragg effects, diffraction efficiency can approach 33 percent; a thick-phase hologram, theoretical diffraction efficiency can approach the limit of 100 percent.³⁵ This means that a thick-phase hologram can diffract almost all of the illuminating light into one of the hologram images, real or virtual, and can produce a very bright display from a dim light source.

Phase recordings can be made from silver halide plates by bleaching a developed and fixed transmittance type hologram. Diffraction efficiency of the hologram is greatly increased by this process, but the linear range of the recording is unaffected.

The concept of linear recording range must be expanded to deal with phase media. Absorption holograms can be characterized by a transmittance versus exposure curve, but a graph of diffraction efficiency versus exposure is a more general method of defining a hologram characteristic and is useful for phase holograms as well as absorption holograms.³⁶ When various recording media are compared on a diffraction efficiency versus exposure basis, it is obvious that certain phase-only media have the longest linear range. Most important among these media are dichromated gelatine and a built-up medium consisting of a thermoplastic film sandwiched with a photoconductor. An investigation of holographic displays using dichromated gelatine as the recording medium was sponsored by ETL.³⁷ It was found that excellent holographic stereomodels could be produced in dichromated gelatine at the expense of great difficulty in exposure. The insensitivity of most phase-type recording media is their greatest drawback. Collier *et al.*, make the point that 15 millijoules per square centimeter should be a maximum exposure level for a reasonable recording medium.³⁸ This criterion limits phase media to certain surface deformable types such as the thermoplastic sandwich material mentioned above.

Color Displays

The reproduction of color scenes by holography requires the recording of three separate holograms for each view, in analogy with the three color separations required

³⁵ R. J. Collier, C. B. Burkhardt, and L. H. Lin, *Optical Holography*, Academic Press, New York, 1971, p. 268.

³⁶ *Ibid*, p. 276.

³⁷ J. T. McCrickard and G. H. Glaser, *Stereoscopic Terrain Display for Measurement Applications*, Northrop Corporation, U.S. Army Engineer Topographic Laboratories, Fort Belvoir, VA, Report No. ETL-0002, AD A008 085, December 1974.

³⁸ R. J. Collier, *et al*, *op. cit.*, pp. 269, 270.

for lithography, color photography, color TV, etc. This means that six separate holograms must be recorded in order to reconstruct a color holographic stereomodel. There are two methods available to the holographer for achieving color images. One method is to use three separate laser light wavelengths to illuminate the holograms, and the other method is to use interference phenomena to filter white light into the three desired colors.

Experience has narrowed the choice between these two methods to the white light case. If three laser beams are used to reconstruct a color image

“... the speckle pattern produced on the retina of the observer would cause him to see a coarser pattern from red than from green and a smaller pattern from blue than from green. In addition, as he moves his head while fixing his eyes on the display, the red speckle pattern would appear to move slower than green, and green would move slower than blue.

This effect is disconcerting and leads to observer fatigue.”³⁹

This problem points up a principle; coherent light is not good for imaging, particularly where a small aperture system like the human eye is used for viewing the image.

Clay and Gore used a recording method in which the color separations were recorded as focused-image holograms separated by rotation of the reference beam about the plate normal.⁴⁰ Reproduction then was accomplished by three white light sources with color filters; the sources being placed at the proper angles so that the three reconstructed color separations are viewed in registration. The holograms are recorded on a photoresist that is then etched, metallized, and used as a die to emboss replica holograms in clear plastic. Although the photoresist is quite insensitive, the replication process allows the exposure per replicated image to be very low and, therefore, very efficient. Photoresist also has a long linear range that allowed the recording of three focused-image holograms, a Fourier transform hologram for frame number access, and a Fresnel hologram for x-y location within a frame; all to be recorded on the same sensitive area. This must be a record use of different types of holograms on the same recording area.

Although this hologram is a thin hologram, volume or Bragg-type holograms offer definite advantages over thin holograms for multicolor imaging. False color reconstructions are eliminated without the necessity of increasing resolution, contrast, or space-bandwidth product.⁴¹ Pennington and Lin used the Bragg effect to prevent false color

³⁹ B. R. Clay and D. A. Gore, “Holographic Moving Maps Display,” *Proceedings of SPIE*, Vol. 45, p. 149.

⁴⁰ F. J. Collier, C. B. Burkhardt, and L. H. Lin, *Optical Holography*, Academic Press, New York, 1971, p. 514.

⁴¹ J. Pennington and L. H. Lin, “Multicolor Wavefront Reconstruction,” *Applied Physics Letters*, Vol. 7, 1 August 1965, pp. 56, 57.

reconstruction when laser light was used to illuminate the hologram. False color occurs when an image intended to be reconstructed by a light beam of a certain color is overlaid with an image of another color reconstructed from the same color separation hologram by another light beam.⁴² The most important use of Bragg diffraction is found when thick holograms are recorded with object and reference beams entering the plate 180° apart along the plate normal as described earlier (figure 5). A focused-image reflection hologram can be reconstructed in full color with a diffuse white light source if three separate reflection holograms, corresponding in their Bragg plane spacings to the three colors necessary for good color reconstruction, are multiplexed in the emulsion. Some striking results have been demonstrated with this type of hologram but a great deal of care is required to make it.⁴³

Stability requirements for reflection holography are very critical, and shrinkage of the emulsion by only a few percent in thickness will shift the wavelength reflected by the hologram by unacceptable amounts, causing false color in the reconstructed image. These holograms can also only be made as absorption holograms because of the current lack of bleaching processes that do not distort the Bragg planes. This limits reconstruction efficiencies to very low values on the order of 1 percent.⁴⁴ Although these problems presently rule out the use of reflection holograms for holographic stereo-models, they are not fundamental stumbling blocks but are engineering problems that may be solved some day, at which time the reflection hologram may come into its own as a display medium.

An interesting problem related to reconstruction of full color holograms is the reconstruction of white light or achromatic hologram images. The focused image hologram viewed in white light reconstructs through the whole spectrum, the color of the image depending on the observer's eye position. Two things are wrong with this. First, most of the illuminating light is diffracted away from the observer's eye, and second the image is seen in color, whereas black and white would be a more natural reconstruction. Both of these deficiencies can be corrected by introducing a compensating grating after the hologram, which produces an equal but opposite dispersion (figure 21).

"As a consequence of the double diffraction, the reconstructed wave appears in the direction of the illuminating wave. In effect, hologram and grating together diffract as a single hologram formed with subject and reference source centered on the same axis. This means that the image generated by the reconstructed wave must be viewed against a background of undiffracted light as in the Gabor in-line holograms. In the present case the undiffracted light may be screened out by inserting a venetian-blind light shield between hologram and grating."⁴⁵

⁴² R. J. Collier, C. B. Burkhardt, and L. H. Lin, *Optical Holography*, Academic Press, New York, 1971, p. 220.

⁴³ G. Stroke and A. Labeyrie, "White Light Reconstruction of Holographic Images Using the Lippmann-Bragg Diffraction Effect," *Bell System Tech. Journal*, Vol. 45, 1966, p. 659.

⁴⁴ R. J. Collier, C. B. Burkhardt, and L. H. Lin, *Optical Holography*, Academic Press, New York, 1971, p. 520.

⁴⁵ *Ibid*, pg 502.

If a point white light source such as a zirconium arc is used, achromatic white light images from Fresnel holograms can also be reconstructed using dispersion compensation.

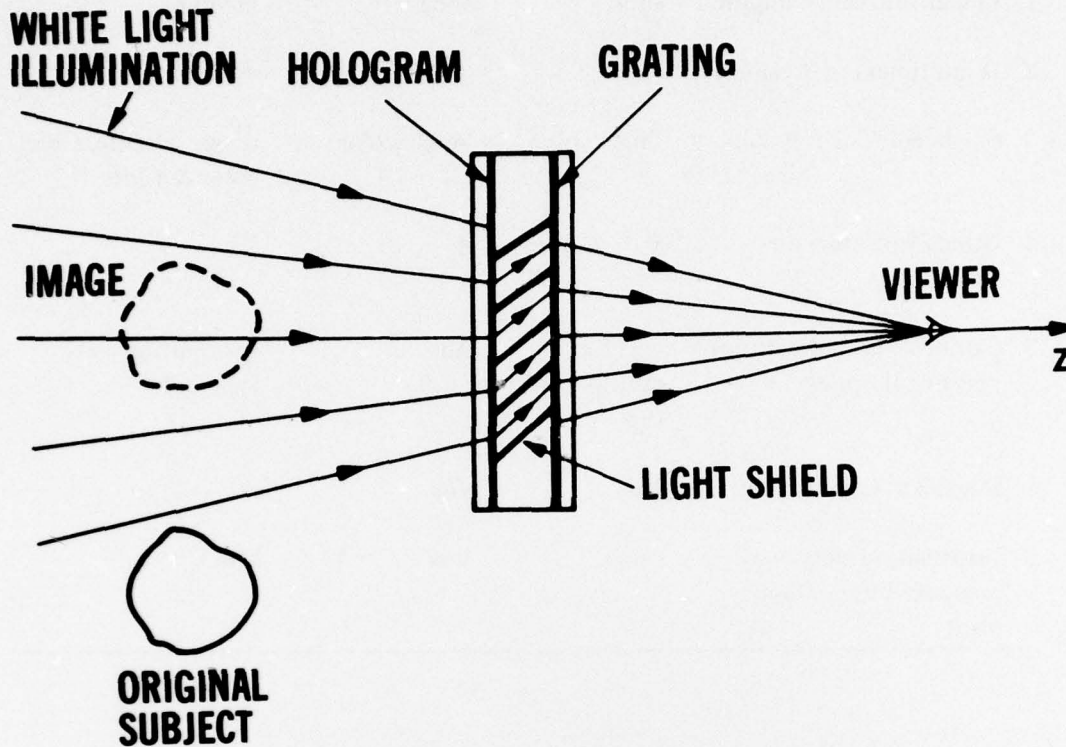

Figure 21. Black and White Hologram Image

V. SUMMARY AND DISCUSSION

Summary.

Four tables have been prepared. Table 1 shows comparison between hologram types used to prepare holographic stereomodels; Table 2 shows characteristics of holographic stereomodels related to reconstruction light sources; Table 3 compares thick holograms; and Table 4 compares photography with CFP and focused-image holography. These topics for comparison were chosen because of their importance in any holographic imaging system. There are some redundancies in these tables so that each may be complete in itself.

Table 1. Selected Characteristics for Common Types of Holographic Stereomodels

	Fresnel	Fourier Transform	CFP and Focused Image
1. Linear film range required	short	long	medium
2. Is multiplexing possible?	yes	no	difficult
3. Single color or full color	single color	single color	range of colors incl color & white
4. Number of observers possible	1	1	1
5. Can it be viewed without additional optics?	yes, for multiplexed type	no	yes, multiplexed type only
6. Is speckle present?	yes	yes	no
7. Information efficiency compared to contact print	low	low	low

Table 2. Characteristics of Holographic Stereomodels Related to Reconstruction Light Sources

	Coherent	Incoherent
1. Is speckle present?	yes	no
2. Can a full range of colors be derived?	no	yes
3. Is the light source available under field conditions?	no	yes
4. What types of holograms may be reconstructed?	all types	CFP and focused image

Table 3. Comparison of Selected Characteristics of Thin and Thick Holograms

	Thin	Thick
1. Is Bragg effect present?	no	yes
2. Can diffraction orders be discriminated against?	no	yes
3. Can the hologram be bleached?	yes	yes, but more difficult
4. Is there a problem with emulsion shrinkage for silver halide recording materials?	no	yes
5. Can the hologram be easily replicated?	yes, for surface holograms such as photo-resist	no
6. Theoretical diffraction efficiency in one order (bleached).	33%	100%
7. Diffraction efficiencies achieved in practice.	30%	45%

Table 4. Comparison of Photography with CFP and Focused Image Holographic Stereomodel Selected Characteristics

	CFP and Focused-Image HSM	Photography
1. Can a 3-D view be seen without additional optics or special light sources?	yes	no
2. Number of observers possible without special optics.	1	many
3. Light efficiency	40%	<10%
4. Information efficiency	low	high
5. Can terrain measurements be made from the display?	yes, but somewhat difficult	yes
6. Is the stereomodel always relatively oriented?	yes	no

Discussion.

Some of the characteristics of holographic stereograms are not optimum for display. Table 1 shows that none of the hologram types discussed can be viewed by more than one person at a time. The information efficiency is low for holographic stereomodels because of the field of view requirements. This may not be a problem because of the availability of high resolution recording media, except that the sensitivity of these media is low and resulting energy requirements for hologram recording are therefore high in comparison to photography.

The fact that only one person at a time may view a holographic stereomodel could be a severe restriction in some situations, however there are circumstances in which this would not be bothersome. For example, a forward observer for artillery would not need to share his view, nor would a downed pilot attempting to locate himself.

A perusal of table 1 will reveal why the CFP and focused-image holograms have been strongly considered for holographic stereomodels. No auxiliary optical system is needed to view the recorded scene in stereo; and an incoherent light source, such as the sun or a flashlight, is all that is required for reconstruction. Furthermore, the reconstruction efficiency can be as great as 40 percent, giving a very bright display from a dim light source. There is no speckle in the reconstructed image, which can be viewed as a black and white or full color image with the proper type of reconstruction.

Table 2 lists some of the reasons why incoherent light is desirable as a reconstruction source. Its superior imaging characteristics and easy availability are balanced by the fact that only focused-imaged and CFP holographic stereomodels can be reconstructed with incoherent light. This is not a serious restriction, since these types of hologram are desirable for display. A good review of holograms reconstructed with incoherent light can be found in a recent popular article by Leith.⁴⁶

Table 3 is a review of some of the characteristics of thin and thick holograms. The difficulties of making a thick hologram have to be balanced against its positive characteristics in any given system, and table 3 can provide a check list for this purpose. The most effective use of thick holograms is in situations where many images must be multiplexed without cross talk, as in recording a color holographic stereomodel where six separate recordings (three color separations for each stereoview) must be multiplexed.

The chief advantages of the focused-image holographic stereomodel over photography can be seen in table 4. A unique feature of all focused-image holographic stereomodels is that a 3-D presentation can be viewed without additional optics. The use of

⁴⁶ E. N. Leith, "White-Light Holograms," *Scientific American*, Vol. 235, October 1976, p. 80.

illuminating light in the image is also very efficient. This can be particularly important under low ambient light, or when it is important to conceal light. Relative orientation of the model is preserved despite the light source used.

A good principle to keep in mind when evaluating the possible use of a holographic display is that holography should only be used when it offers performance that is difficult or impossible to achieve by ordinary photography.⁴⁷ Despite this general principle, several possible applications have been identified by Kurtz for "annotated metric quality" focused image holographic stereomodels which can be used as 3-D photomaps.⁴⁸ Additional applications with lower accuracy requirements can be listed for holographic stereomodels in general:

1. *Holographic Training Aids in Map Compilation.* The holographic stereomodel would replace a stereoscope as a means of viewing a scene in 3-D to aid photointerpretation. The stereophoto model must be adjusted each time it is used. This is a slow process compared to setting up a pre-oriented holographic stereomodel. Standard terrain features, along with their map symbols, can also be recorded as training aids for map compilers.

2. *Training Aids in Map Interpretation and Land Navigation.* This is the inverse of the problem stated above. Map users should become familiar with terrain and cultural features referred to by map symbols. A training set of symbols and associated *holographic stereomodels of terrain* would be a great aid in this training. A feeling for the undulation of terrain as shown by contours could also be easily gained by holographic stereomodel views of selected map areas.

3. *Special Navigation Tasks.* This is a catchall category including escape and evasion on land, nap-of-the-earth flying, combat patrol, and other tasks where the user may not have the time for interpretation of a conventional map. The holographic stereomodel can show the user his situation in a moment. The fact that holographic stereomodels are made from photography also gives the user more information than a line map. Symbolology can be added to the holographic stereomodel to aid interpretation.

VI. CONCLUSIONS

Applications in the mapping community for terrain holographic stereomodel displays will require that they be fairly accurate, cheap, easy to reproduce, and have good pictorial quality without image defects such as speckle, ghost images, and dis-

⁴⁷ G. L. Rogers, "When To Use Holography . . . and When Not To," *Optical Spectra*, Vol. 4, November 1970, pp. 20-23.

⁴⁸ M. K. Kurtz, "Found! Some More Practical Applications for Holograms," *Proceedings of S.P.I.E.*, Vol. 45, 1974.

tracting colors. All of these defects are problems to be solved, but none of them are intrinsically unsolvable. Because of the intimate connection between the quality of a hologram and the type of recording medium used, a program investigating holographic recording media is currently being pursued in the Research Institute at ETL. Other work considering the recording and reconstruction geometries and techniques could profitably be pursued with solution of the problems mentioned above as the goal. Achievement of a standard high quality terrain holographic stereomodel capability will require extensive work.