

AD-A035 177

CALSPAN CORP BUFFALO N Y
ARIES (AGGREGATE RECOVERABLE ITEM EVALUATION SYSTEM) MODEL AND C--ETC(U)
JUN 73 D P VANARSDALL
CALSPAN-TA-5175-0-18

F/G 16/4.1
F33657-72-C-1013
NL

UNCLASSIFIED

1 OF 1
AD
A035177



END
DATE
FILMED
3-77

ADA035177

①



Calspan

Technical Report

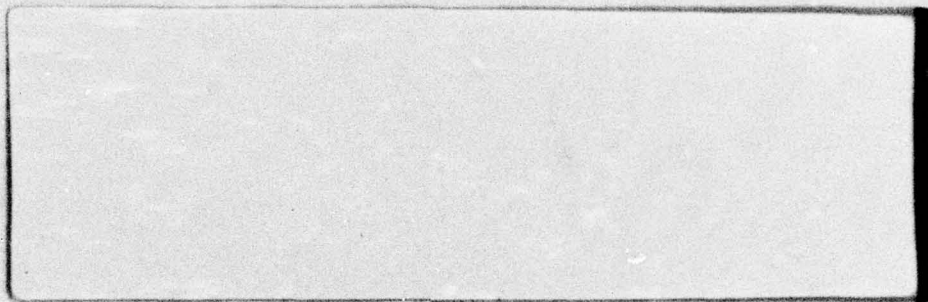

Q26
529185

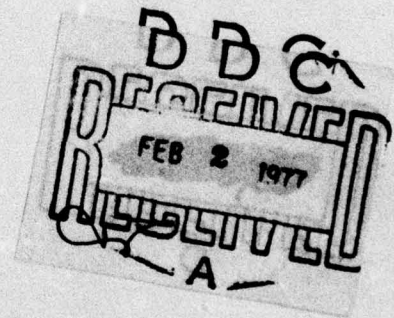

DISTRIBUTION STATEMENT A

**Approved for public release;
Distribution Unlimited**

Calspan Corporation
Buffalo, New York 14221

Formerly Cornell Aeronautical Laboratory, Inc.

⑨ Mechanical Dept.

Calspan

On November 17, 1972 Cornell Aeronautical Laboratory (CAL) changed its name to Calspan Corporation and converted to for-profit operations. Calspan is dedicated to carrying on CAL's long-standing tradition of advanced research and development from an independent viewpoint. All of CAL's diverse scientific and engineering programs for government and industry are being continued in the aerosciences, electronics and avionics, computer sciences, transportation and vehicle research, and the environmental sciences. Calspan is composed of the same staff, management, and facilities as CAL, which operated since 1946 under federal income tax exemption.

⑥ ARIES (Aggregate Recoverable Item Evaluation System)
Model and Computer Program

⑩ David P. Vanarsdall

⑪ Jun 73

Calspan Report No. TA-5175-Q-18

⑫ 89p.

⑭ CALSPAN-7A-5175-Q-18

Prepared For:
AGM-86A PROGRAM OFFICE
AFSC, AERONAUTICAL SYSTEMS DIVISION
WRIGHT-PATTERSON AFB, OHIO 45433

⑮
June 1973
Contract No. F33657-72-C-1013

DDC
REF ID: A66116
FEB 8 1977
A

DISTRIBUTION STATEMENT A
Approved for public release
Distribution Unlimited

Calspan Corporation
Buffalo, New York 14221

407727

✓B

FOREWORD

The ARIES model was developed by Calspan Corporation (formerly Cornell Aeronautical Laboratory, Inc.) as one task of its System Engineering Technical Assistance (SETA) contract with the AGM-86A Program Office (RW 86) of the Aeronautical Systems Division (ASD) of the Air Force Systems Command (AFSC). The model was defined during the period February 1972 to June 1972 under Contract No. F33657-72-C-0228. Portions of the model were programmed on the IBM 370/165 computer, located at Calspan, Buffalo, New York, during the period July 1972 to September 1972 under Contract No. F33657-72-C-1013. The final testing and checkout of the model computer program were accomplished on the CDC 6600 computer at ASD, Wright-Patterson AFB, Ohio.

This report contains a general discussion of the scope and practical applications of the model from the Integrated Logistics Support (ILS) manager's point of view, a rigorous technical discussion of the model for operations researchers, and a description of the model computer program and its applications.

Lt. Col. L. Davila-Aponte and Mr. John Burchett of the ILS Division of the AGM-86A Program Office were the USAF monitors during the development of the model.

Messrs. E. Pringle and T. Wojcinski and Dr. W. Fryer contributed to the model computer program development at Calspan's Buffalo, New York, Advanced Technology Center, and Dr. Sol Kaufman of Calspan's Operations Research Department at the Center provided technical assistance in the review and development of the analytic structure of the model.

SEARCHED BY	
DATE	7/12/72
BY	Paul Secora
CLASSIFIED	<input type="checkbox"/>
JUSTIFICATION	<input type="checkbox"/>
<i>Letter on file</i>	
BY	
DISTRIBUTION/AVAILABILITY CODES	
1.1	AVAIL. AND/OR SPECIAL
<i>A</i>	

ABSTRACT

ARIES is a computerized mathematical model which assists ILS managers in their planning. It enables them to optimize recoverable item component reliabilities, maintenance capabilities, and maintenance strategies -- as well as initial stockage levels for the multi-echelon base-depot supply system -- while taking into account the corresponding impact upon system availability and life cycle cost for unscheduled maintenance.

Item demand is assumed Poisson. There are four alternative maintenance strategies for an item, and the strategy choice is a variable in the problem. Rather than considering only an item's unit cost, the model computes the item's 10-year life cycle cost for unscheduled maintenance. The sum of item expected backorders across all bases is minimized, subject to a life cycle cost constraint for unscheduled maintenance. The item expected backorder versus cost function can have large regions of non-convexity. The resource expenditure algorithm for the model incorporates allocations from these non-convex regions to provide solutions near a constraint. The maximum region of uncertainty for the minimized expected backorder sum is defined, and this provides a basis for judging the quality of the result.

ARIES evaluates the minimized expected backorder solution to determine the expected number of NORS vehicles for both the case where complete cannibalization of parts is assumed and the case where there is no cannibalization. The ARIES solution defines the expected backorder value for each item; this parameter is a necessary input to the MSCAM model to perform refined reliability/maintainability trade-offs on the individual items. The manpower and item stockage level requirements for the individual bases and depot are determined by the ARIES solution.

(This page intentionally left blank)

TABLE OF CONTENTS

<u>Section</u>	<u>Title</u>	<u>Page</u>
I	INTRODUCTION	1
II	SUMMARY	3
III	GENERAL DISCUSSION	4
	ILS MODELING OBJECTIVES	4
	LIMITATIONS WITH PREVIOUSLY DEVELOPED ILS MODELS	5
	ORLA (Optimum Repair Level Analysis) Model	5
	AFLC Drone-LSC (Life Support Cost) Model	5
	METRIC (Multi-Echelon Technique for Recoverable Item Control) Model	6
	GENERAL DESCRIPTION OF ARIES	6
	USE OF THE EXPECTED NORS vs LCC (UNSCHEDULED MAINTENANCE) CURVE	8
	USE OF THE ITEM EXPECTED BACKORDER VALUES	9
	MANPOWER REQUIREMENTS	10
	COMMON AGE (AEROSPACE GROUND EQUIPMENT)	10
	TYPES OF TRADE-OFFS THAT CAN BE MADE.	11
IV	TECHNICAL DISCUSSION	12
	MODEL OBJECTIVES	15
	MODEL ASSUMPTIONS	15
	Item Demand is Poisson	16
	Multi-Echelon Repair	16
	Four Alternative Maintenance Strategies	16
	(s-1,s) Policy at Base	17
	Condemnations	17
	No Lateral Resupply	17
	Item Demand is Stationary During the Life Cycle Period	17
	Resupply Time is Independent of Demand	17
	Base-to-Depot Item Demand Can Be Pooled	18

TABLE OF CONTENTS (Cont.)

<u>Section</u>	<u>Title</u>	<u>Page</u>
IV (Cont.)	Equal Base and Item Essentialities	18
	Minimum of One Unit of Stock Per Item	18
	Minimizing the Sum of Base Expected Backorders	18
	INPUT DATA	19
	Data Common to All Items	19
	Item Data	19
	Problem Data	20
	ANALYTIC STRUCTURE OF ARIES	20
	Mathematical Problem Definition	20
	Item Expected Backorder-LCC Function	22
	Convexification of the Item Expected Backorder-LCC Function	24
	Iteration To a Problem Constraint	24
	Expected NORS Evaluation	27
	EXAMPLE	31
	MODEL USAGE	36
	CONCLUSION	39
	APPENDIX	41
	ACKNOWLEDGEMENT	43
	REFERENCES	43
V	COMPUTER PROGRAM	45
	PROGRAM LOGIC ORGANIZATION	45
	Module 1 - MSCAM2	45
	Module 2 - Optimum Item BO-LCC Function	45
	Module 3 - Determination of the Region Where a Constraint is Met	47
	Module 4 - Compute Solution at Constraint	48
	Module 5 - Calculate Base and Item-Depot Summaries	49

TABLE OF CONTENTS (Cont.)

<u>Section</u>	<u>Title</u>	<u>Page</u>
V (Cont.)	Subroutine Structure	49
	Program Execution Sections and Disc Data Files	49
	INPUT DATA	52
	TYPICAL PROGRAM USAGE	57
	DEFINITION OF VARIABLES	58
	OUTPUT DISPLAYS	58
	COMPUTATION TECHNIQUES	63
	Subroutines STOCK and SPO	63
	Subroutines PDIST and PD2	64
	Subroutine HULL	64
	PROGRAM CHECKOUT	65
Supplement A	EXAMPLE PROBLEM INPUT AND OUTPUT DATA	66
Supplement B	TEST CASE WITH SOME SRUs THAT REQUIRE MORE THAN ONE UNIT PER VEHICLE	73

LIST OF ILLUSTRATIONS

<u>Figure</u>	<u>Title</u>	<u>Page</u>
0	ARIES Analysis of System Availability vs LCC for Unscheduled Maintenance	9
1	Sum of Expected Backorders vs LCC for Each of Four Alternative Maintenance Strategies for Item (i)	23
2	Maximum Areas of Uncertainty for Optimal Solutions Using the Original Item Expected Backorder - LCC Functions	26
3	Expected Backorders and Expected NORS vs LCC for the Example Problem	35
4	ARIES Computer Program Overview Flow Diagram	46
5	Macro Flowchart of the ARIES Computer Program Subroutines . . .	50

LIST OF TABLES

<u>Table</u>	<u>Title</u>	<u>Page</u>
I	Comparison of Allocation Algorithms for Minimizing the Sum of Expected Backorders	32
II	Comparison of Allocation Algorithms for Minimizing the Sum of Expected NORS When Cannibalizing	32
III	Functional Description of ARIES Subroutines	51
IV	Input Data Format for the ARIES Model	53
V	Definitions of Some of the Variables Appearing in ARIES	59
VI	Sample Output Format for the ARIES Base Summary Data	61
VII	Sample Output Format for the ARIES Item-Depot Summary Data	62
VIII	Example Problem Input Data for the XX-Array (Card Group VI)	68
IX	Total System Sum of Expected Backorders and LCC for the Example Problem	69
X	Sample Printout of the KJ-Array for the Example Problem	71
XI	Item and Depot(s) Summary Printout Display for the Example Problem	72
XII	Test Case (With Some $u_i > 1$) Input Data for the XX-Array (Card Group VI)	75
XIII	Comparison of Allocation Algorithms for Minimizing the Sum of Expected Backorders for the Test Case With Some $u_i > 1$	77
XIV	Comparison of Allocation Algorithms for Minimizing the Sum of Expected NORS When Cannibalizing for the Test Case With Some $u_i > 1$	77
XV	Total System Sum of Expected Backorders and LCC for the Test Case with Some $u_i > 1$	78
XVI	Sample Printout of the KJ-Array for the Test Case with Some $u_i > 1$	79
XVII	Item and Depot(s) Summary Printout Display for the Test Case With Some $u_i > 1$	80

Section I
INTRODUCTION

A weapon system designed to perform near the state-of-the-art in a performance sense (e.g., in range, speed, accuracy) is a dubious asset if it is nearly always down because of: (1) equipment failure, (2) a low probability of repair within an acceptable time interval, or (3) a high probability of a shortage of the replacement spare parts. Consequently, "availability" becomes an important measure of total system effectiveness. Availability is the resultant interaction of the quantitative aspects of system component reliabilities, maintainability capabilities, and supply support effectiveness.

Additionally, it is a design goal to achieve an acceptable level of system availability subject to minimizing the total life cycle cost for the weapon system. The total life cycle cost for an item, segment, or system is the sum of acquisition, operation, and maintenance costs. This report discusses a mathematical model that assists the PO in the decision-making process by deriving system component reliabilities, maintenance strategies, and deployment stockage levels while taking into account the corresponding impact upon system availability and life cycle costs for unscheduled maintenance.

The technical discussion of the ARIES model (Section IV) was developed and written in a style suitable for submittal to a professional journal for review and potential publication. The journal requires that papers be double-spaced, reference rather repeat previous work, etc.; therefore, to save the time and costs associated with re-doing the technical discussion of the model in the typical Calspan report format, Section IV is essentially an unaltered version of the "journal-style" paper. The double-spacing offers the reader additional freedom to make notes and comments within the text of the discussion.

The remaining sections of the report were prepared using the conventional reduced line spacing but in a format that is consistent with Section IV to assist in the ease of reader comprehension. The General Discussion in Section III has been developed with the objective of minimizing the amount of technical details while still providing the reader with a sufficient overview of the model.

Section II

SUMMARY

This report presents a technical discussion of a computerized mathematical model developed by Calspan Corporation to assist the AGM-86A Program Office in evaluating and in reducing the logistics costs of the SCAD weapon system. The model is applicable to other weapon systems that have a logistics system which is similar to the SCAD base-depot concept.

The ARIES model is used to derive the optimum weapon system logistics configuration for unscheduled maintenance for recoverable items (Shop Replaceable Units, SRUs) as a function of system availability and 10-year life cycle costs.

The features of the model that assist the ILS manager in identifying and reducing weapon system life cycle costs for logistics are:

- Consideration of four alternative maintenance strategies;
- Calculation of life cycle costs (unscheduled maintenance);
- Creation of a permanent data base;
- Permitting of analyses at various cost constraints without recalculating the data base;
- Use of simple Poisson distribution for demand;
- Provision of a resource allocation algorithm that derives solutions which are within 1 percent accuracy for most realistic problems;
- Relation to operational measures of effectiveness;
- Provision of continuity with the individual SRU reliability/maintainability trade-off data and model;
- Computation of base and depot unscheduled maintenance manpower requirements; and
- Provision of useful base summary and item-depot summary output.

Section III GENERAL DISCUSSION

This section presents a general discussion of the requirement for and the practical application of the ARIES model from the ILS manager's point of view. The mathematical details of the ARIES model are discussed in Section IV.

ILS MODELING OBJECTIVES

The military services have been under increasing pressure in recent years to estimate and reduce the cost of developing, deploying, and operating new sophisticated weapon systems. The "cost growth" phenomenon of past weapon systems has brought about enough attention that, once the requirements have been established for a new weapon system, the following order of priorities tends to prevail: (1) cost, (2) performance, and (3) schedule.

The logistic support costs for a weapon system account for a significant portion of the total weapon system cost over the life cycle of the deployed system. In 1964, the Department of Defense issued Directive 4100.35 describing the Integrated Logistics Support (ILS) concept. Since then, the Services have been required to consider, estimate, and evaluate the life cycle costs (LCC) implied by the design alternatives encountered throughout the acquisition process. By providing improved methods for making trade-off evaluations early in the weapon systems design phase, attention can be focused upon reducing life cycle costs before significant funds are committed to a design or concept.

It has been the objective of the Calspan technical support effort for the ILS function of the SCAD program to review previously developed ILS models, to modify/develop appropriate ILS models for SCAD, and to assist in the implementation of the models. The MSCAM model (originally developed at the RAND Corporation and subsequently modified by Calspan) has been made available to the SCAD PO to evaluate the reliability/maintainability characteristics of

individual SRUs (Shop Replaceable Units)* and how these characteristics affect the life cycle cost, stockage levels, and alternative maintenance strategies. The ARIES model has been developed by Calspan for the SCAD PO to evaluate the aggregate effect upon system availability and life cycle costs for all SCAD SRUs.

LIMITATIONS WITH PREVIOUSLY DEVELOPED ILS MODELS

A review has been made, and is continuing to be made, of previously developed ILS models that have been suggested for application to the SCAD program by organizations other than Calspan. The following paragraphs summarize the principal limitations of some of the previous ILS models and emphasize the need that existed for a new model which could improve the SCAD ILS modeling applications to reduce life cycle costs.

ORLA (Optimum Repair Level Analysis) Model

ORLA does not employ a stockage level computation procedure that permits the planner to estimate the stockage cost required to meet a specified level of system performance. Additionally, the effectiveness of computed stockage levels is not made explicit. Thus, the costs computed for alternative repair strategies do not necessarily correspond to the same levels of system performance. The ORLA model does not include an alternative maintenance strategy for base-depot repairs.

AFLC Drone-LSC (Life Support Cost) Model

The LSC model assumes that the initial stockage level is equal to the peak demand month. This assumption is arbitrary and does not apply to SCAD, for there is no peak demand month as there is potentially in an aircraft weapon system. The model does not consider and compute optimum maintenance strategies.

*The terms "SRU" and "item" are used interchangeably throughout this report.

METRIC (Multi-Echelon Technique for Recoverable Item Control) Model

The METRIC model, developed at the RAND Corporation, provided the original concept for evaluating all recoverable items in a weapon system on an aggregated basis while minimizing the sum of total expected backorders across all bases. However, METRIC has the following limitations: (1) life cycle costs are not considered, (2) alternative maintenance strategies that could vary with the level of LCC expenditure are not considered, (3) great emphasis is placed upon describing the demand distribution (i.e., Bayesian estimation procedures for the compound Poisson distribution, which entail calculations that are of questionable marginal value considering the likely accuracy of the total set of input parameters), (4) the item condemnation rates are assumed to be zero (i.e., every item is assumed to be repairable at either the base or depot), and (5) the output data are not as readily usable and complete as is desirable for the SCAD systems analysis.

GENERAL DESCRIPTION OF ARIES

ARIES is a computerized mathematical model used to derive the optimum total weapon system 10-year life cycle cost for unscheduled maintenance as a function of system availability. The operational measure of system availability is the expected number of NORS (Not Operationally Ready - Supply) missiles for the case when complete cannibalization of parts is assumed and for the case when cannibalization is not permitted. ARIES is applicable to any weapon system that utilizes the base-depot maintenance concept.

Within ARIES, the measure of effectiveness "the sum of expected item backorders across all bases" is minimized in the optimization process. A demand for an item that cannot be satisfied from base supply is a backorder or due-out. The expected backorder measurement takes into account the duration of an unsatisfied demand as well as the fact that it occurred. The process of minimizing the sum of expected backorders provides a close approximation to the process of minimizing the operationally oriented NORS measure of effectiveness (no-cannibalization case).

The input data to ARIES include: all the individual SRU data, which are essentially the same data processed individually with the Calspan version of the MSCAM model; data describing the number of bases and depots in the problem and the number of missiles at each base; and data defining the constraint for total system LCC (unscheduled maintenance).

The ARIES model processes the individual SRU data independently to derive the optimum stockage levels, maintenance strategy, and expected backorder sum across all bases as a function of the LCC (unscheduled maintenance) for the item. The resultant data from the individual SRU calculations are stored on a permanent disc file for later processing in the model. The permanent file eliminates redundant SRU computations and provides a data bank for future analyses.

Using a resource allocation algorithm, ARIES computes the optimum logistics configuration for each SRU that will provide the greatest amount of system availability relative to an input value for total LCC (unscheduled maintenance). The solution at the cost constraint defines the optimum maintenance strategy, stockage levels, and expected backorder value for each SRU. By supplying the model with the proper execution option, useful summary data may be computed for each base and also at the depot(s).

Since the LCC for logistics is only one part of the total LCC for a weapon system, the results from an analysis of unscheduled maintenance should be merged with the costs for other phases of the system to influence the total LCC to be optimized. To illustrate, there is a point beyond which increasing the system acquisition cost of an SRU to improve reliability and maintainability characteristics will not be offset by a corresponding decrease in the unscheduled maintenance cost.

* There are four alternative maintenance strategies: base-depot repair, depot-only repair, base-only repair, and discard upon failure.

While ARIES was developed for use in analyzing the logistics of a weapon system, the model is also applicable to other non-defense logistics systems that have a similar base-depot maintenance concept involving high-cost, low-demand recoverable parts (e.g., a computer system network or a telecommunications system).

USE OF THE EXPECTED NORS VS LCC (UNSCHEDULED MAINTENANCE) CURVE

An important curve may be constructed that shows the relationship between optimum system availability (logistics) and LCC (unscheduled maintenance). The curve is derived by solving the logistics allocation problem with ARIES for a range of cost constraints that cover the region of feasible solutions. Figure 0 illustrates the principal curves that were constructed from the analysis of the example problem, which is discussed in more detail in Section IV and Supplement A. The curves of Figure 0 show how the expected number of NORS missiles, for both the complete-cannibalization and no-cannibalization cases, decreases as the expenditure for LCC (unscheduled maintenance) increases. The dashed line in the figure represents the expected backorder curve until it essentially coincides with the expected NORS curve for the no-cannibalization case. In the Air Force logistics planning activity, reliance is placed primarily upon the expected NORS for the case where no cannibalization is assumed.

In using Figure 0, the logistician should select a design point on the curve that at least meets the weapon system's specification for logistics availability and that also takes into consideration the marginal return from additional logistics investment (i.e., the marginal expenditure for LCC to reduce the expected NORS by one does not exceed the life cycle cost to procure an additional missile). If one were to consider "some" cannibalization, the curve for it would lie inside the two curves for the cases assuming no cannibalization and complete cannibalization.

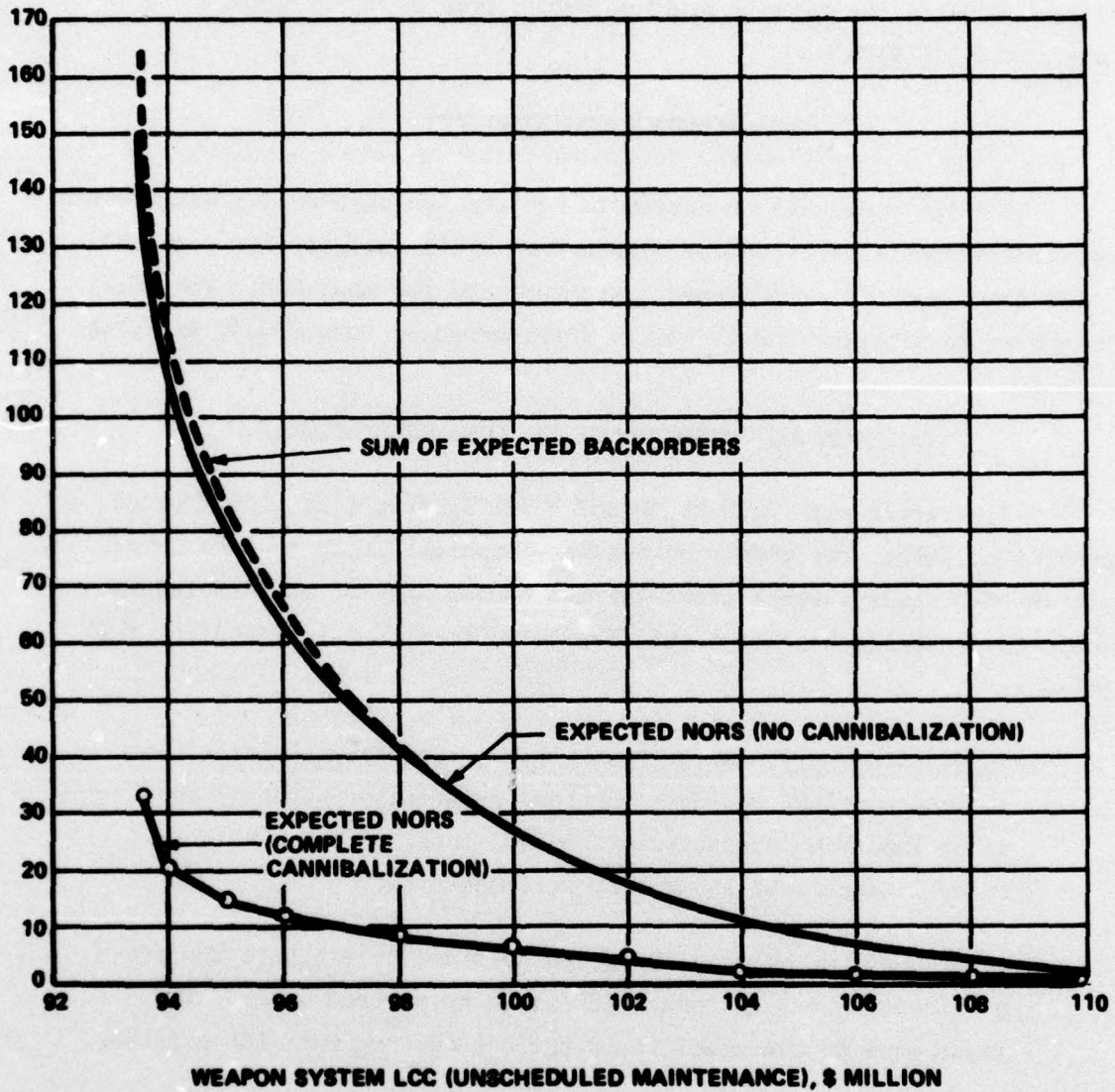

Fig. 0. ARIES Analysis of System Availability vs LCC for Unscheduled Maintenance

USE OF THE ITEM EXPECTED BACKORDER VALUES

The planner has in effect selected a LCC (unscheduled maintenance) constraint point after he has performed the analyses discussed above. Corresponding to the cost constraint point, there is a solution that defines the expected backorder value for each SRU. The SRU expected backorder value is a necessary input to the MSCAM model to perform refined reliability/maintainability

trade-off analyses on each individual item. The expected backorder values for the sixteen SRUs in the example problem ranged from 0.042 to 1.476 at a cost constraint of \$106 M.

MANPOWER REQUIREMENTS

The ARIES model has an option to compute the unscheduled maintenance manpower requirements at each base within each skill category for each SRU. Also, the depot manpower requirements are computed for each SRU. The total base manpower requirement and the total depot manpower requirement are also summarized.

COMMON AGE (AEROSPACE GROUND EQUIPMENT)

A limitation with both MSCAM and ARIES is that items are treated independently; hence, the models do not have explicit logic to take into account the fact that several items may use common AGE for unscheduled maintenance. Three approaches are identified below to assist in remedying this situation.

Grouping items - It may be possible to group several items that use the same AGE and have the same maintenance strategy and other important characteristics and, thus, to treat these items in the model as if they were one item.

Prorating AGE expenses - It may be possible to estimate the proportionate share of common AGE usage by several items. The input data to the model would reflect the pro rata AGE expenses.

Attributing entire AGE expense to one item - It may be appropriate to attribute the entire AGE expense to only one item from among several that potentially could use the same common AGE. This situation may be justifiable if one item has been planned for AGE-assisted repair in any eventuality.

It may be necessary to iterate through the solution several times to arrive at the proper procedure for accommodating the common AGE expenses.

TYPES OF TRADE-OFFS THAT CAN BE MADE

Obviously, the types of trade-offs that can be made with any model are variations of the many combinations of input variables. For the ARIES model, it is convenient to summarize the principal parameters for trade-off analyses according to the following categorization:

Reliability

- Failure rates
- Operating hours per base per month

Maintainability

- Base and depot AGE
- Base and depot repair capability:
 - (1) Man-hours per repair
 - (2) Repair parts cost per repair
 - (3) Repair turnaround time

Availability

- System deployment concept
- Expected item backorders across all bases
- Expected NORS vehicles

Item Characteristics

- End-item cost
- NRTS (Not Repairable This Station) and condemnation rates.

Section IV TECHNICAL DISCUSSION

ARIES is a mathematical model for the multi-echelon base-depot supply system for recoverable items. Item demand is Poisson. There are four alternative maintenance strategies for an item and the strategy choice is a variable in the problem. Rather than considering only an item's unit cost, the model computes the item's 10-year life cycle cost for unscheduled maintenance. The sum of item expected backorders across all bases is minimized subject to a life cycle cost constraint for unscheduled maintenance. The item expected backorder versus cost function can have large regions of non-convexity. The resource expenditure algorithm for the model incorporates allocations from these non-convex regions to provide solutions near a constraint. The maximum region of uncertainty for the minimized expected backorder sum is defined and this provides a basis for judging the quality of the result. ARIES evaluates the minimized expected backorder solution to determine the expected number of NORS vehicles for both the case where complete cannibalization of parts is assumed and the case where there is no cannibalization. The manpower and item stockage level requirements for the individual bases and depot are determined by the ARIES solution.

THIS PAPER discusses a new logistics model, ARIES, that combines and extends the features of two previously-developed models to achieve a more general analytic treatment for the multi-item, multi-echelon supply system for recoverable parts. The METRIC model [8] analyzed aggregate recoverable item problems while considering only an item's unit cost and parameters that defined a single maintenance strategy for the item for all ranges of resource allocations. The MSCAM (Manpower, System support Cost Analysis Model) model [5,12] has as its objective the analysis of an individual recoverable item for each of four alternative maintenance strategies to determine the 10-year life cycle cost (unscheduled maintenance) and the base and depot stockage levels corresponding to a given input value for the item sum of expected backorders across all bases.

The military services have been under increasing pressure in recent years to estimate and reduce the cost of developing, deploying, and operating new sophisticated weapon systems. The "cost growth" phenomenon of past weapon systems has brought about enough attention such that, once the requirements have been established for a new weapon system, the following order of priorities tends to prevail: (1) cost, (2) performance, and (3) schedule.

The logistic support costs for a weapon system account for a significant portion of the total weapon system cost over the life cycle of the deployed system. In 1964, the Department of Defense issued Directive 4100.35 describing the Integrated Logistics Support (ILS) concept. Since then the Services have been required to consider, estimate and evaluate the life cycle costs (LCC) implied by the design alternatives encountered throughout the acquisition process. By providing improved methods for making trade-off evaluations

early in the weapon systems design phase, attention can be focused upon reducing life cycle costs before significant funds are committed to a design or concept.

Within the SCAD (Subsonic Cruise Armed Decoy for the B-52 aircraft) program, the MSCAM model was modified for use to perform refined reliability/maintainability parameter trade-offs for individual recoverable items that are called SRUs (Shop Replaceable Units). Since a key input variable to the MSCAM model is the expected backorder value for each item, the requirement existed to develop an aggregate model to derive the target value for the item sum of expected backorders across all bases when one considers LCC and four alternative maintenance strategies. Another feature the aggregate model required is that it relate to an operational measure of effectiveness for system availability.

Since the LCC for logistics is only one part of the total LCC for a weapon system, the results from an analysis of unscheduled maintenance should be merged with the costs for other phases of the system to influence the total LCC to be optimized. To illustrate, there is a point beyond which increasing the system acquisition cost of an SRU to improve reliability and maintainability characteristics will not be offset by a corresponding decrease in the unscheduled maintenance cost.

While ARIES was developed for use in analyzing the logistics of a weapon system, the model would be applicable to other non-defense logistics systems that have a similar base-depot maintenance concept involving high-cost, low-demand recoverable parts, e.g., a computer system network or a telecommunications system.

MODEL OBJECTIVES

ARIES is a computerized mathematical model to assist the ILS manager in the decision-making process for optimizing system component reliabilities, maintenance strategies, and deployment stockage levels while taking into account the corresponding impact upon system availability and LCC for unscheduled maintenance. For brevity, the term LCC shall refer to life cycle cost for unscheduled maintenance for the remainder of the paper. Subject to a given cost constraint, ARIES minimizes the expected sum of item backorders across all bases. The operational measure of effectiveness to which availability is best related to by operational personnel is the expected number of NORS (Not Operationally Ready - Supply) vehicles. The solution for the expected backorder result can be evaluated to determine the corresponding expected number of NORS vehicles. By the systematic evaluation of a range of cost constraints, a useful curve may be derived to show the relationship between availability and LCC.

A fallout of the LCC analysis is the determination of the number of men required in each skill category at the bases and depot to perform unscheduled maintenance. ARIES is structured as a computer model that realizes the benefits from creating a permanent data file for individual item expected backorder-LCC functions and this facilitates future analyses by eliminating the need to recalculate all the item data when the same basic system is under study and only a few parameters are being changed.

MODEL ASSUMPTIONS

The mathematical assumptions describing the structure of the model are given below. Since many of the assumptions are the same as those previously described for METRIC^[8], only a brief mention of them will be made here to define the problem.

Item Demand Is Poisson

The probability distribution characterizing item demand arrivals is assumed to be Poisson. Considering the typical accuracy of item failure data that is available, particularly during the design phase of a weapon system, the simple Poisson distribution represents a reasonable choice for the model (also, see reference 9, p. 632). As a consequence of this assumption, demand is a stochastic process with independent increments.

Multi-Echelon Repair

Item demand may be satisfied at either a base or depot. Each item has one depot. The depot need not be the same for all items. The maintenance strategy that is selected for an item will determine where repair is permitted.

Four Alternative Maintenance Strategies

Each item will have one of the following maintenance strategies corresponding to a given resource expenditure level: repair at both base and depot, (BD); repair at the depot only, (D); repair at the base only, (B); and no repair-discard upon failure, (NR).

When a demand occurs at the base, it will be repaired there with probability $1-r$ or sent to the depot for repair/replacement with probability r . In the vernacular of logistics, r is referred to as the NRTS rate (Not Repairable This Station). For the D and NR strategies, the value of r is one. When applying the multi-echelon theory to compute an item's expected backorder sum, it is necessary to estimate the average depot resupply time. The depot resupply time is the sum of the average delay for depot repair and the round trip base-depot-base order and shipping time. For the B and NR

strategies, the "depot repair time" is equal to the average factory re-order time for the item.

(s-1,s) Policy at Base

The one-for-one replacement inventory policy, (s-1,s), is assumed at the bases.

Condemnations

For the B and NR maintenance strategies the condemnation rates are r and 1.0, respectively, and, hence, base condemnations and subsequent depot replacements are treated by the (s-1,s) policy. The condemnation rate at the depot for the BD and D strategies is an input parameter that is usually under 5 percent. The model considers the effect of condemnations for the BD and D strategies only to the extent that it affects recurring stockage costs and ignores the small effect it would have on the depot resupply time.

No Lateral Resupply

Simplifying the problem is the assumption that there is no lateral resupply among the bases. During the planning phase, it is not Air Force policy to consider the lateral exchange of stock as a source of inventory.

Item Demand Is Stationary During the Life Cycle Period

While this assumption may be more difficult to accommodate for aircraft systems that have a widely varying use rate, it is quite appropriate for many missile systems, since the demand rate during the life cycle period is relatively constant.

Resupply Time Is Independent of Demand

The time to resupply an item at the base or depot is independent of the demand occurring (infinite channel queuing model).

Base-To-Depot Item Demand Can Be Pooled

The net effect of the demand from all the bases to the depot can be pooled to form a resultant new Poisson distribution. The depot demand rate is the sum of the individual base-to-depot demand rates.

Equal Base and Item Essentialities

ARIES is presently structured to treat each base and each item with the same importance. Any item can cause a NORS.

Minimum of One Unit of Stock Per Item

The model assumes the system has a minimum of at least one unit of stock per item in inventory. This assumption facilitates computing the minimum LCC for the system and the corresponding expected NORS. Logistics planners indicate that operational managers would require there be at least one unit per item in inventory.

Minimizing the Sum of Base Expected Backorders

A demand that can not be satisfied from base supply is a backorder or due-out. The backorder measurement takes into account the duration of a demand as well as the fact that it occurred. The model minimizes the sum of item expected backorders across all bases. As will be discussed later, the process of minimizing the sum of expected backorders provides an excellent approximation to the process of minimizing expected NORS for the case when there is no cannibalization.

INPUT DATA

The input data to the model can be categorized into data that is common to all items, individual item data, and peculiar problem data. The following inputs are included in ARIES. Many of the parameters are

necessary to compute the non-recurring and recurring costs that go into the LCC computations.

Data Common To All Items

Total operating hours for all vehicles at each base per month.

Base-depot distances and order and shipping times.

Base and depot manhour cost rates.

Packaging and shipping rate costs.

Ten-year uniform series present worth factor. This factor is necessary for combining the annual recurring cost with the non-recurring cost to determine the present value for the 10-year LCC.

Item Data

Failure rate. The equipment "on" and "off" time failure rates are reduced to one number that when multiplied by the total vehicle operating hours and the number of item units per vehicle yields the expected item demand per base per month.

Base and depot AGE (Aerospace Ground Equipment) cost per unit.

AGE installation and set-up cost.

Annual operating and maintenance cost per AGE.

Average number of hours that depot AGE is used per repair.

Item unit cost, shipping weight, NRTS rate, and condemnation rate.

Base and depot average repair time manhours.

Base and depot average repair turnaround times.

Base and depot repair parts cost per repair. This is the cost of consumable parts per repair.

Average base manhours to detect, to remove, and to replace a failed item.

Proportion of repairs performed by each of the base labor skill categories.

Number of pages of technical data.

Procurement lead time.

Number of units of the item used per vehicle.

Problem Data

Lagrange multipliers.

LCC and sum of expected backorder constraints.

Number of vehicles at each base.

A discussion of the calculations that go into computing the LCC is found in reference 5. Briefly, the non-recurring and recurring costs are a summation of the costs for stockage, AGE, transportation, and repair (labor and materials). The ARIES model has provision to accommodate a fraction of the BD and B maintenance strategy base repair and AGE costs for the D and NR strategies. This feature reflects the cost at the base to detect, to remove, and to replace failed items that are either sent to the depot or discarded.

ANALYTIC STRUCTURE OF ARIES

The model has three principal logical steps. The first step performs a sub-optimization to derive the individual item expected backorder-LCC functions. The second step employs Lagrange multiplier and marginal allocation techniques to reach a solution at a problem constraint. And last, the third step evaluates the expected backorder solution at a constraint in terms of its corresponding expected NORS values.

Mathematical Problem Definition

ARIES solves either of two single-constraint problems that require

non-negative integer solutions. Define $\beta(s_{i0}, s_{ij}, m_i)$ to be the expected backorders for item i at base j when the depot and base have been stocked with initial spares of s_{i0} and s_{ij} , respectively, and the maintenance strategy is m_i , ($i = 1, 2, \dots, I$). Also, define $LCC(s_{i0}, s_{i1}, \dots, s_{iJ}, m_i)$ to be the LCC for item i when the spare units are allocated $s_{i0}, s_{i1}, \dots, s_{iJ}$ to the depot and bases $1, 2, \dots, J$, respectively and the maintenance strategy is m_i . Having indicated the dependence of expected backorders and LCC on the particular selection of stock levels and maintenance strategy, let us now simplify the notation by suppressing the latter variables, i.e., β_{ij} for $\beta(s_{i0}, s_{ij}, m_i)$ and LCC_i for $LCC(s_{i0}, s_{i1}, s_{i2}, \dots, s_{iJ}, m_i)$. The two optimization problems are the following: Find the allocation $\{s_{ij}; 1 \leq i \leq I, 0 \leq j \leq J\}$ and maintenance strategy $\{m_i; 1 \leq i \leq I\}$ which

$$\begin{aligned} &\text{minimizes} && \sum_{i,j} \beta_{ij} && (1) \\ &\text{subject to} && \sum_i LCC_i \leq C, \end{aligned}$$

where C is a constraint for the system LCC. Alternatively, find $\{s_{ij}\}$ and $\{m_i\}$ which

$$\begin{aligned} &\text{minimizes} && \sum_i LCC_i && (2) \\ &\text{subject to} && \sum_{i,j} \beta_{ij} \leq B, \end{aligned}$$

where B is a constraint for the total system sum of expected backorders at the bases and β_{ij} and LCC_i are defined as in problem (1). Discussion will center about problem (1) since it is generally the one of principal interest.

It has been shown^[8] that problems (1) and (2) can be reformulated into the form of equation (3) when the item expected backorder-LCC functions are convex. In the case of ARIES, we are using the item LCC instead of the item unit cost, but this in no way affects the validity of equation (3). Thus, find $\{s_{ij}\}$ and $\{m_i\}$ which minimizes

$$F = \sum_{i,j} \beta_{ij} + \lambda \sum_i LCC_i, \quad (3)$$

where $\lambda > 0$ is an unknown Lagrange multiplier. Since F can be treated as a separable cell integer programming problem, one can take advantage of restricting attention to one item at a time: minimize

$$F_i = \sum_j \beta_{ij} + \lambda LCC_i, \quad (i = 1, 2, \dots, I). \quad (4)$$

Summing the F_i , $F = \sum F_i$. The multi-echelon theory that derives the basic expression for β_{ij} is presented in [8]. A theorem, useful for computational purposes, on the recursive expression for an item expected backorder sum is given in the appendix.

Item Expected Backorder-LCC Function

To facilitate solving equation (4), it is first necessary to calculate for each item and for each of the four maintenance strategies the set of allocations which are undominated - in the sense that each point $(\sum_j \beta_{ij}, LCC_i)$ of that set in the expected backorder-LCC plane is either below or to the left of every other allocation point. This set is called the item expected backorder-LCC function (pure maintenance strategy). Figure 1 illustrates how the four pure maintenance strategy expected backorder versus LCC discrete functions could look for an item. The functions are monotonically decreasing and, in this example, they alternately dominate each other at different regions over the range of LCC.

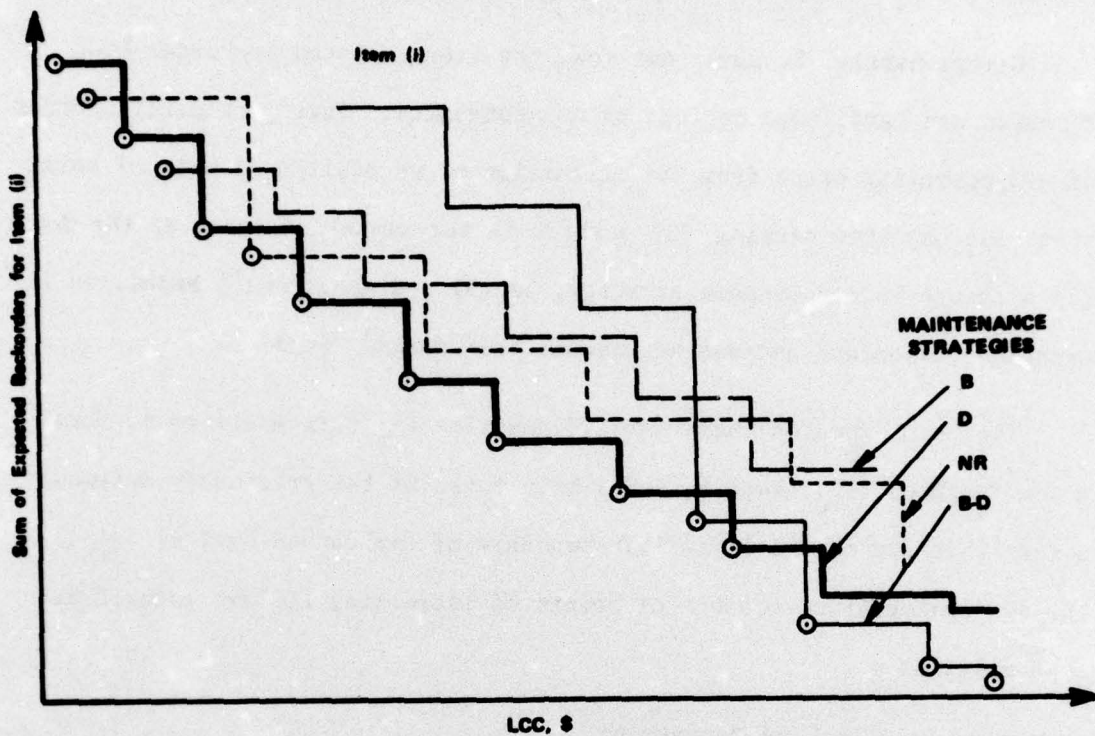

Fig. 1. Sum of Expected Backorders vs LCC for Each of Four Alternative Maintenance Strategies for Item (i)

The model collapses the four functions into one suboptimal expected backorder sum-LCC function for item i ; call it $\{\zeta_{in}\}$ where ζ_{in} represents the expected backorder-LCC pair $(\sum_j \beta_{ij}, LCC_i)$ at the n^{th} point in the undominated set in the direction of increasing LCC. The circled points in Figure 1 illustrate the undominated set in the example. Within the computer program for the model, a large savings in computation is realized by testing whether a previously-calculated strategy dominates the one under current processing. ARIES computes the strategies in the order of BD, D, B and NR and this is generally the order of decreasing selection frequency.

Convexification of the Item Expected Backorder-LCC Function

Unfortunately, it turns out that the item expected backorder-LCC function can have large regions of non-convexity. Three potential sources of non-convexity arise from the allocation of an additional unit of total stock for the item causing (1) a shift in the amount of stock at the depot, (2) a change in maintenance strategy, or (3) a disproportionate reduction in expected backorders because of unequal base demand rates.

The item expected backorder-LCC function $\{\tau_{in}\}$ is modified to form a new function $\{\tau'_{ip}\}$ that includes only those of the originally defined points that are on the lower left boundary of the convex hull of $\{\tau_{in}\}$. The new consecutive sequence of points of increasing LCC are indexed by the subscript p .

Iteration To a Problem Constraint

In the second principal logical step there are three stages in the process of minimization under a problem constraint. For a given Lagrange multiplier λ and the convex functions $\{\tau'_{ip}\}$, ($i = 1, 2, \dots, I$), equations (3) and (4) may be solved, i.e., minimize the F_i and, thus, F . This solution is representable by the I -tuple of integers (p_1, p_2, \dots, p_I) identifying the selected points from each item expected backorder-LCC function, i.e., $((\sum_j \beta_{ij}) p_i, (LCC_i) p_i)$. If equations (3) and (4) are solved for a given set of λ_k , ($k = 1, 2, \dots, K$), then a test can be made to determine between which two λ_k a problem constraint is met; call the two bounding Lagrange multipliers λ_{m-1} and λ_m .

The model employs incremental marginal allocation with the functions $\{\zeta'_{ip}\}$ starting from the point in resource expenditure defined by the solution at λ_{m-1} . The marginal allocation procedure iteratively selects and allocates to the item i for which the quantity ϕ_i , as given by equation (5), is a maximum and stops when a constraint would be first violated.

$$\phi_i = [(\sum_j \beta_{ij})_{q-1} - (\sum_j \beta_{ij})_q] / [(LCC_i)_q - (LCC_i)_{q-1}], \text{ where } q=p_i. \quad (5)$$

Whenever an allocation is made, $q = p_i$ is increased by one. The solution generated by the marginal allocation with ϕ_i is an optimal allocation of resources for its corresponding expenditure (or expected backorder sum); however, the solution is not, in general, optimal for the problem constraint.

Starting with the solution determined by marginal allocation with ϕ_i from equation (5), a heuristic marginal allocation algorithm is next applied, but now using all points from the original functions $\{\zeta_{in}\}$. The procedure iteratively selects and allocates to the item i for which the quantity θ_i , as given by equation (6), is a maximum until there is no remaining item allocation left that will not violate a constraint.

$$\theta_i = [(\sum_j \beta_{ij})_{t-1} - (\sum_j \beta_{ij})_t] / [(LCC_i)_t - (LCC_i)_{t-1}], \text{ where } t=n_i. \quad (6)$$

Whenever an allocation is made, $t=n_i$ is increased by one. The 1-tuple of integers (n_1, n_2, \dots, n_I) identifies the solution at any point in the final allocation process.

The final marginal allocation procedure does not guarantee that the exact optimal solution will be found since allocations may be made from non-convex regions of the $\{\zeta_{in}\}$ functions. The maximum region of uncertainty for the minimized expected backorder sum can be defined, and this provides a basis for

evaluating the quality of a resulting solution. Using the $\{\zeta'_{ip}\}$ functions and a sufficiently large set of λ_k , the entire array of Lagrange multiplier solutions may be derived. The circled points in Figure 2 represent how the solutions would appear. These solutions have the following properties:

- (i) Connecting adjacent solutions by straight line segments yields a convex polygonal line; and
- (ii) No solution corresponding to either the convexified functions $\{\zeta'_{ip}\}$ or the original item functions $\{\zeta_{in}\}$ can occur below the connecting convex polygonal line.

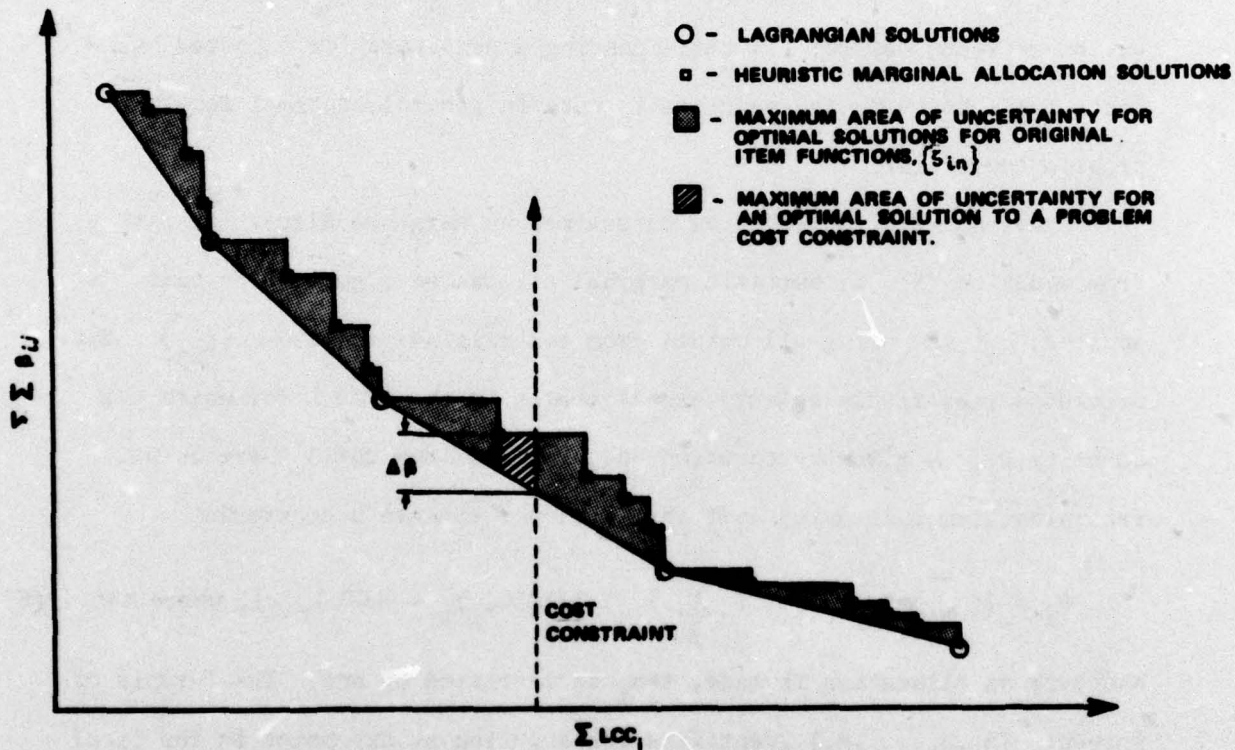

Fig. 2. Maximum Areas of Uncertainty for Optimal Solutions Using the Original Item Expected Backorder - LCC Functions

Property (i) follows from the fact that when the Lagrange multiplier formulation is applied incrementally (iterative marginal allocation) to a

set of convex functions the resultant solutions constitute a new function that is also convex, i.e., the function and slope will be monotonically decreasing and increasing, respectively. Property (ii) is true for the $\{\tau'_{ip}\}$ functions by the very nature of Lagrangian analysis providing an undominated sequence of solutions. Property (ii) is true for the $\{\tau_{in}\}$ functions since allocations from non-convex regions must lie above and to the right of the tangent lower bounding hyperplanes (convex polygonal line in ARIES) to the *envelope* for the entire set of all possible solutions in the $(\sum_{i,j} \beta_{ij}, \sum_i LCC_i)$ space. [2]

By connecting the Lagrangian and the final heuristic marginal allocation solutions with horizontal and vertical lines, as shown in Figure 2, the area enclosed between these lines and the convex polygonal line defines the region of maximum uncertainty for optimal solutions when considering the original item expected backorder-LCC functions $\{\tau_{in}\}$. The maximum region for uncertainty for the solution corresponding to a cost constraint is illustrated in Figure 2 by the cross-hatched area. The difference between the solution that is obtained and the theoretical minimum possible expected backorder sum is denoted by $\Delta\beta$ in the Figure.

Expected NORS Evaluation

The third principal logical step in the model takes the item stockage levels corresponding to a problem constraint minimized expected backorder sum solution and computes the expected number of NORS vehicles for both the case when complete cannibalization is assumed and the case where there is no cannibalization. The sum of expected NORS for the case with complete

cannibalization is a function of the item in shortest supply at each of the bases.

For each base j , define ψ_j by the following expression:

$$\psi_j = \max_{1 \leq i \leq I} (\beta_{ij}/u_i), \quad (7)$$

where u_i is the number of units of item i used per vehicle. The item in shortest supply at base j is defined as that i which maximizes the expression in equation (7). Summing ψ_j over all the bases yields the expected NORS for the cannibalization case

$$E(\text{NORS})_c = \sum_j \psi_j. \quad (8)$$

Contrary to Sherbrooke's tentative conclusion^[9], the process of minimizing the sum of expected backorders provides only a fair approximation to the process of minimizing $E(\text{NORS})_c$. Attacking the minimization of $E(\text{NORS})_c$ more directly with a final allocation algorithm that identifies the next expenditure by selecting the item that has a maximum for the quantity $\sum_j \beta_{ij}/u_i$, one tends to generate cost constraint solutions that have a significantly lower value for $E(\text{NORS})_c$. However, the corresponding expected backorder sum is significantly larger than that which is obtained by the marginal allocation algorithm, i.e., equations (5) and (6). Miller^[6] has shown that the $E(\text{NORS})_c$ -cost function is convex when restricting the solution to $\{\tau'_{ip}\}$ and that any one of several non-linear programming techniques could be applied to find the optimum. The example discussed in a later section illustrates the extent of the $E(\text{NORS})_c$ differences between the two ARIES algorithms for approaching a problem constraint. Since in the Air Force logistics planning activity reliance is placed primarily upon the expected NORS for the case where no cannibalization is assumed, $E(\text{NORS})_{nc}$, it was considered sufficient and practical

to use the algorithm that employs $\sum_j \beta_{ij}/u_i$ in the model as an approximation for the minimum value of $E(\text{NORS})_c$.

Underlying the Air Force reliance on $E(\text{NORS})_{nc}$ is the concept that cannibalization should only be used as a fall-back technique in the event that actual item demand and/or resupply times are higher than previously anticipated. The value for $E(\text{NORS})_{nc}$ is derived as follows:

Let $P_1 = \text{Pr}$ (the first unit selected for item i on a random vehicle at base j is backordered),

$P_2 = \text{Pr}$ (the second unit selected for item i on a random vehicle at base j is backordered | first unit is not backordered),

⋮

$P_{u_i} = \text{Pr}$ (the u_i^{th} unit for item i on a random vehicle at base j is backordered | the previous $u_i - 1$ units are not backordered),

and

$v_j =$ the number of vehicles at base j , then

$$P_1 = \beta'_{ij}/v_j u_i, P_2 = \beta''_{ij}/(v_j u_i - 1), \dots, P_{u_i} = \beta_{ij}^{(u_i)}/[u_i(v_j - 1) + 1], \quad (9)$$

where $\beta_{ij}^{(k)}$ is the expected backorders for item i at base j when the demand rate λ_{ij} is decreased by the factor $(v_j u_i - k + 1)/v_j u_i$. Assuming independence of item unit demand, the probability that a vehicle is not NORS due to item i at base j is A_{ij} ,

$$A_{ij} = \prod_{k=1}^{k=u_i} (1 - P_k). \quad (10)$$

Since it would require extensive computations to calculate P_2, P_3, \dots, P_{u_i} , and the decrease in the numerator will be approximately equal to the decrease in the denominator in equation (9), the simplifying approximation is made that $P_1 = P_2 = \dots = P_{u_i}$. Assuming item demand independence, the probability

a vehicle is not NORS at base j is $\prod_i A_{ij}$ where,

$$\prod_i A_{ij} \approx \prod_i (1 - \beta_{ij}/v_j u_i)^{u_i} \quad (11)$$

Hence, the expected total number of NORS vehicles across all bases is given by equation (12).

$$E(\text{NORS})_{nc} \approx \sum_j v_j (1 - \prod_i A_{ij}) \quad (12)$$

The $E(\text{NORS})_{nc}$ function is non-separable; however, the process of minimizing the sum of expected backorders provides an excellent approximation to the process of minimizing $E(\text{NORS})_{nc}$. This fact can be shown by examining the expansion of equation (12) and rearranging terms. Initially, assume all $u_i = 1$, then

$$\begin{aligned} E(\text{NORS})_{nc} &= \sum_j v_j \left[1 - \left(1 - \frac{\beta_{1j}}{v_j} \right) \left(1 - \frac{\beta_{2j}}{v_j} \right) \cdots \left(1 - \frac{\beta_{Ij}}{v_j} \right) \right] \\ &= \sum_{i,j} \beta_{ij} - \sum_j \frac{1}{v_j} \sum_{i < k} \beta_{ij} \beta_{kj} + \sum_j \frac{1}{v_j^2} \sum_{i < k < l} \beta_{ij} \beta_{kj} \beta_{lj} \\ &\quad + \cdots + \sum_j \frac{(-1)^{I-1}}{v_j^{I-1}} \prod_i \beta_{ij} \end{aligned} \quad (13)$$

Since all $\beta_{ij} < v_j$, $E(\text{NORS})_{nc}$ is equal to the sum of expected backorders minus the sum of terms involving increasing orders of β_{ij}/v_j up to the order $I-1$ in the last term. The effect of having some $u_i > 1$ is to increase the number of such terms. For the situation when $\beta_{ij} \ll v_j$,

$$E(\text{NORS})_{nc} \approx \sum_{i,j} \beta_{ij} \quad (14)$$

If the item demand rates remain unchanged but the number of vehicles v_j is varied, an increase in v_j will further reduce the difference between the expected backorder sum and $E(\text{NORS})_{nc}$.

EXAMPLE

Consider a problem with 16 items, 17 bases, one depot, all $u_i = 1$, and an unequal number of vehicles at the bases. The other input values to the model for the example are too numerous to mention here but let it be remarked that a representative range of item unit costs, demand rates, and AGE costs are in the problem.

The results for the solution corresponding to eleven cost constraints are summarized in Tables I and II. The first cost constraint dictates the solution for the minimum number of units of stock for the system, i.e., one per item. The remaining constraints cover a range of LCC values down to the point where there is very little improvement left that can be made in system availability. There are three alternative allocation algorithms presented in Table I and they are defined below:

Algorithm 1 - Using only the points on the convexified item functions, $\{\tau'_{ip}\}$, marginal allocation, i.e., equation (5), is employed until a constraint would be first violated.

Algorithm 2 - Starting from the algorithm 1 solution and using the item functions $\{\tau'_{ip}\}$, repeated marginal allocations are made until there remains no item allocation that would not violate a constraint.

Algorithm 3 - Starting from the algorithm 1 solution and using the original item functions $\{\tau_{in}\}$, repeated marginal allocations are

TABLE I
COMPARISON OF ALLOCATION ALGORITHMS FOR MINIMIZING
THE SUM OF EXPECTED BACKORDERS

COST CONSTRAINT \$, M	SUM OF EXPECTED BACKORDERS			MAXIMUM PERCENT POSSIBLE REDUCTION FOR SOLUTION			E(NORS) _{nc}		
	1	2	3	1	2	3	1	2	3
93.5	162.6	162.6	162.6	0.23	0.23	0.23	149.8	149.8	149.8
94	112.1	111.6	111.5	0.62	0.12	0.05	106.0	105.5	105.4
95	90.3	86.1	85.5	5.63	0.76	0.05	86.3	92.5	81.9
96	67.0	66.7	66.6	0.65	0.12	0.07	64.8	64.4	64.4
98	42.7	42.6	42.6	0.27	0.06	0.06	41.9	41.8	41.8
100	28.9	27.9	27.7	4.30	0.75	0.19	28.4	27.5	27.3
102	17.7	17.6	17.5	0.80	0.14	0.07	17.5	17.4	17.4
104	11.7	11.0	10.8	8.37	1.36	0.24	11.6	10.9	10.8
106	6.80	6.62	6.62	2.90	0.27	0.20	6.78	6.61	6.60
108	3.47	3.47	3.47	0.07	0.02	0.02	3.47	3.46	3.46
110	2.40	2.20	2.10	14.45	4.86	0.25	2.39	2.19	2.10

TABLE II
COMPARISON OF ALLOCATION ALGORITHMS FOR MINIMIZING
THE SUM OF EXPECTED NORS WHEN CANNIBALIZING

COST CONSTRAINT \$, M	E(NORS) _c					TOTAL NUMBER OF UNITS OF STOCK			Δ LCC UNDER CONSTRAINT, \$		
	1	2	3	4	5	1	2	3	1	2	3
93.5	33.3	33.3	33.3	33.3	33.3	16	16	16	790	790	790
94	20.2	20.2	20.2	15.8	15.8	74	77	77	21,853	1,253	46
95	16.5	16.5	14.7	11.7	11.7	123	147	136	223,038	469	2,118
96	11.9	11.9	11.9	11.2	11.0	177	179	182	28,801	1,592	684
98	8.12	8.12	8.12	8.12	8.51	282	283	283	13,442	642	642
100	7.81	7.81	6.78	5.25	5.12	315	331	324	165,532	4,233	2,146
102	4.17	4.17	4.17	3.34	2.84	369	378	376	33,362	2,086	110
104	2.14	2.14	2.14	1.80	1.85	427	459	435	357,997	4,088	957
106	2.00	2.00	1.82	1.55	1.38	488	496	494	97,494	1,759	1,414
108	0.89	0.89	0.89	0.89	0.85	574	575	575	2,817	417	417
110	0.58	0.56	0.59	0.41	0.43	620	661	623	516,841	678	440

made until there remains no item allocation that would not violate a constraint.

Algorithm 1 corresponds to the best Lagrange multiplier solution that could be obtained. Algorithm 3 is the basic allocation procedure for ARIES, i.e., equations (5) and (6). Algorithm 2 is included for the purpose of examining how much is gained by using the non-convex regions of the item functions $\{\zeta_{in}\}$ in the solution. The columns in Table I for "Maximum Percent Possible Reduction for Solution" are related to $\Delta\beta$ that is illustrated in Figure 2. For this example, the maximum percent possible reduction in expected backorder sum for algorithms 1, 2, and 3 were less than 15, 5, and 0.25 percent, respectively. For a different problem (that is not presented in this paper) that had many items with $u_i > 1$, the corresponding results were 25, 5, and 1 percent for the three algorithms. Based upon these two representative problems, it would appear that *one could expect the application of algorithm 3 to yield solutions within 1 percent accuracy in most realistic situations.* In general, logistics systems will have more than 16 SRU's and this would further reduce the likelihood of a significant impact on the solution arising from the non-convexities in the individual item functions $\{\zeta_{in}\}$.

In addition to algorithms 1, 2, and 3, Table II has algorithms 4 and 5 to compare the $E(\text{NORS})_c$ values to the approach when allocations are selected on the basis of the item that has a maximum for the quantity $\sum_j \beta_{ij}/u_i$.

Algorithm 4 - Starting at the given input Lagrange multiplier which is an upper bound on the constraint, λ_{m-1} , and using the item functions $\{\zeta_{in}\}$, the next allocation is selected by taking the item that has a maxi-

mum for the quantity $\sum_j \beta_{ij}/u_i$ and continuing this process until there is no item allocation remaining that will not violate a constraint.

Algorithm 5 - The same procedure as algorithm 4 except that the starting point is λ_k , where $k = \max(m-2, 1)$.

The results shown in Table II indicate that the process of minimizing the sum of expected backorders does not necessarily minimize $E(\text{NORS})_c$. At various constraint points algorithms 4 and/or 5 have a value for $E(\text{NORS})_c$ significantly lower (up to 31 percent) than algorithm 3. For the problem that is not presented in this paper that has many $u_i > 1$, the results are analogous to the example presented here. Also shown in Table II are the total number of units of stock allocated and the difference between the solution LCC and the problem constraint for LCC.

Figure 3 shows a plot of the example problem results. A continuous dashed line represents the expected backorder curve until it essentially coincides with the $E(\text{NORS})_{nc}$ curve. Thus, for LCC expenditures beyond \$98 M, the value for $E(\text{NORS})_{nc}$ could be approximated by the expected backorder sum with very little error, i.e., the application of equation (14). The bottom (g) curve in Figure 3 represents an approximation to the minimum value for $E(\text{NORS})_c$ and is selected as the minimum value between the solutions for algorithms 4 and 5.

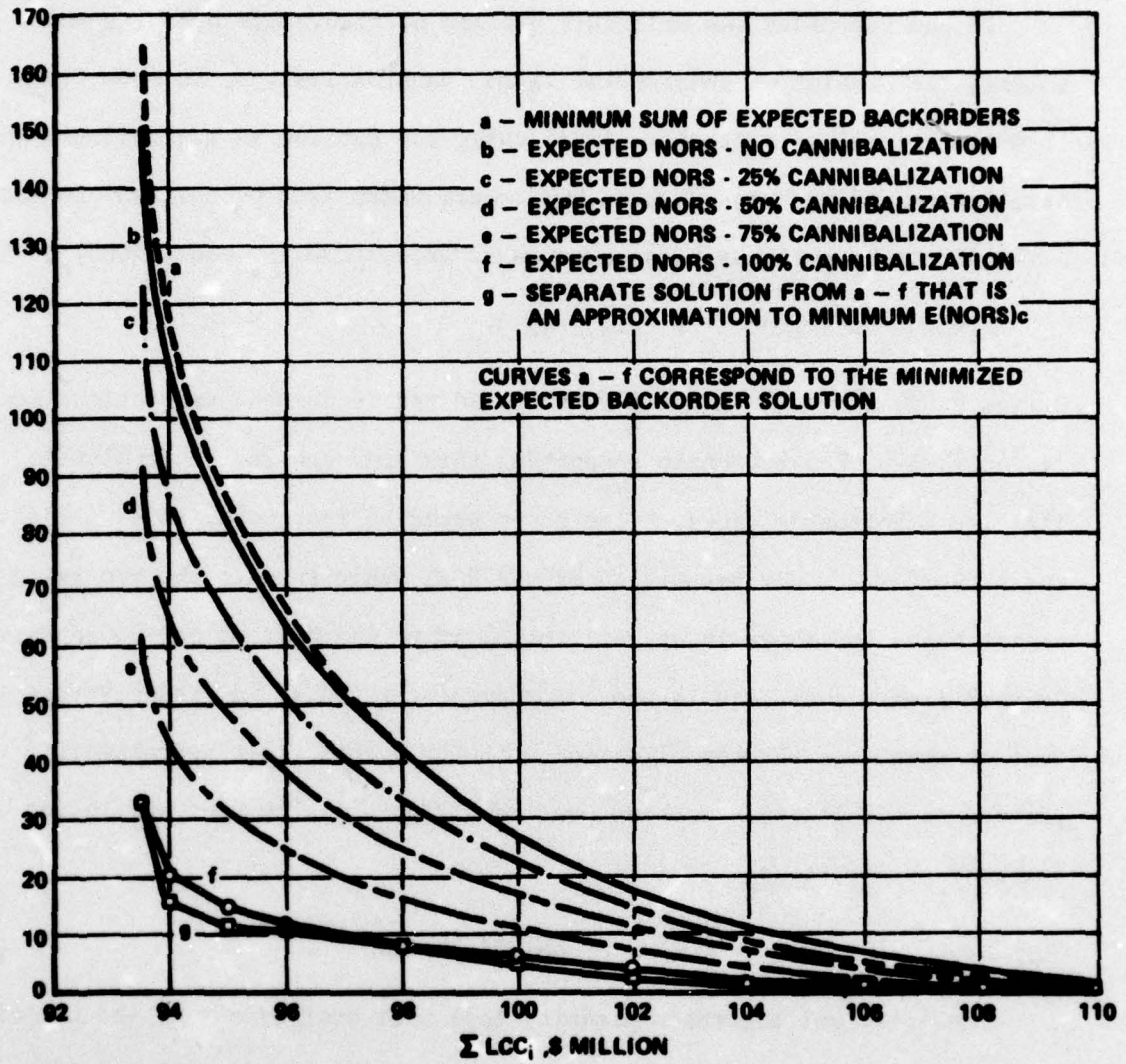

Fig. 3. Expected Backorders and Expected NORS vs LCC for the Example Problem

Notice that the g-curve is not convex; this is due to either the solution being obtained from the non-convex functions $\{z'_{ip}\}$ or the heuristic nature of algorithms 4 and 5, or both.

If one addresses the difficult problem of rigorously defining and solving the problem of considering "some" cannibalization, he soon finds it mathematically intractable. Approaching the problem in a simplistic manner, let us define "the expected NORS where there is x proportion cannibalization" to be a linear interpolation between $E(NORS)_{nc}$ and $E(NORS)_c$; thus,

$$E(NORS)_x = xE(NORS)_c + (1-x)E(NORS)_{nc} . \quad (15)$$

Curves c, d, and e in Figure 3 show 25, 50 and 75 percent cannibalization, respectively. The rationale supporting this approach to the problem is that the maintenance crews at the bases would be instructed to consolidate the backorders from x proportion of the NORS vehicles onto the remaining NORS at the bases and there is no restriction as to which items may be consolidated. Omitted from the problem is the corresponding increase in resupply time and cost arising from the consolidation activity. This first approximation to the partial cannibalization problem provides planning factors of sufficient accuracy for many applications.

MODEL USAGE

The principal logistics planning tool that evolves out of the use of the model is the expected NORS versus LCC functions depicted in an illustration like Figure 3. In using the figure, the analyst wants to select a design point on the curve that at least meets the weapon system's specification for logistics availability and also takes into consideration the marginal return from additional logistics investment, i.e., the marginal expenditure for

$\sum_i LCC_i$ to reduce the expected NORS by one does not exceed the life cycle cost to procure an additional vehicle.

The ARIES solution at the selected LCC constraint defines the expected backorder sum for each item. Target values for the expected backorder sum for each item are a necessary input to the MSCAM model to perform refined reliability and maintainability trade-offs on each item. The expected backorders values for the sixteen items in the example ranged from 0.042 to 1.476 at a cost constraint of \$106M.

A limitation with both ARIES and MSCAM is that items are treated independently and, hence, the models do not have explicit logic to take into account the fact that several items may use common AGE. Three approaches are identified below to assist in remedying this situation.

Grouping items - It may be possible to group several items together that use the same AGE and have the same maintenance strategy and other important characteristics and, thus, to treat these items in the model as if they were one item.

Prorating AGE expenses - It may be possible to estimate the proportionate share of common AGE usage by several items. The input data to the model would reflect the pro rata AGE expenses.

Attributing entire AGE expense to one item - It may be appropriate to attribute the entire AGE expense to only one item from among several that potentially could use the same common AGE. This situation may be justifiable if one item has been planned for AGE-assisted repair in any eventuality.

It may be necessary to iterate through the solution several times to arrive at the proper procedure for accommodating the common AGE expenses.

Obviously, the types of trade-offs that can be made with any model are variations of the many combinations of input variables. For the ARIES model, it is convenient to summarize the principal parameters for trade-off analyses according to the following categorization:

Reliability

- Failure rates
- Operating hours per base per month

Maintainability

- Base and depot AGE
- Base and depot repair capability
 1. Manhours per repair
 2. Repair parts cost per repair
 3. Repair turnaround time

Availability

- System deployment concept
- Expected item backorders across all bases
- Expected NORS vehicles

Item Characteristics

- End-item cost
- NRTS and condemnation rates

The model has an option to compute the unscheduled maintenance manpower requirements for each item at each base within each skill category. Also, the

depot manpower requirements and depot AGE utilization rates are calculated for each item. Subsequently, total base and depot manpower requirements for all items are summarized for convenient usage by the logistics planner.

The computer program for ARIES is written in FORTRAN IV for both the CDC 6600 and the IBM 370/165 computers. The program has three basic execution sections that correspond to the three previously-discussed logical steps. The first execution section processes the item data to generate the individual item functions $\{\zeta_{in}\}$. The common item data, the item data, and the $\{\zeta_{in}\}$ functions are stored on a permanent disc file for later usage. The program has a data management capability to add, subtract, or modify items on the permanent file to define the system currently being analyzed.

The second execution section solves the resource allocation problem subject to a single constraint by first testing to see between which two input Lagrange multiplier constants the solution would lie. The combination Lagrange multiplier and final marginal allocation algorithm reduces the number of calculations over that of simply using marginal allocation the entire way for each constraint. The third execution section solves for the expected NORS and has the option to summarize the solution for each base in the system. A more detailed discussion about the ARIES computer program is contained in reference 11.

CONCLUSION

The ILS effort can be assisted in its function to identify and reduce the logistics life cycle cost for a weapon system by employing an aggregate item model such as described in this paper. The model provides a general analytic treatment for optimizing the multi-echelon logistics system for

unscheduled maintenance by incorporating the following features:

- Treats four alternative maintenance strategies for an item as a variable in the problem;
- Calculates resource expenditures in terms of the life cycle cost;
- Provides an allocation algorithm that produces solutions within 1 percent accuracy for most realistic problems;
- Creates a permanent data base that permits analyses at various cost constraints without having to recalculate the entire data base;
- Relates to an operational measure of effectiveness for availability-expected NORS;
- Provides continuity with the individual SRU reliability/maintainability trade-off data and model;
- Computes base and depot manpower requirements; and
- Provides useful resource allocation and performance data for each base and by item.

APPENDIX

A convenient recursive computational technique to reduce calculations, and to prevent underflow problems in the computer program when either the item demand (λT) or the spare stock (s) is large, for the expected back-order function is given by the following theorem:

THEOREM. *Let s be the spare stock for an item where demands are described by the Poisson distribution with mean arrival rate λ and the resupply (repair) time is drawn from an arbitrary distribution $\Psi(t)$ with mean T , then the expression for the recursive relationship for the expected number of back-orders is*

$$\beta(s+1) = \beta(s) - \alpha(s) + \gamma(s),$$

where (16)

$$\beta(0) = \lambda T, \quad \alpha(0) = 1, \quad \gamma(0) = e^{-\lambda T},$$

$$\alpha(s) = \alpha(s-1) - \gamma(s-1), \quad \text{and}$$

$$\gamma(s) = \gamma(s-1) \lambda T / s.$$

Proof. Sherbrooke [8] has shown that $\beta(s)$ can be described by the expression given by equation (17)

$$\beta(s) = \sum_{k=s+1}^{k=\infty} (k-s)p(k|\lambda T),$$

(17)

where $p(k|\lambda T)$ is the compound Poisson probability function for demands occurring during a mean resupply interval, T . Using the notation $p(k)$ for $p(k|\lambda T)$ and noting that for the simple Poisson $p(k) = (\lambda T)^k e^{-\lambda T} / k!$, then the expansion of equation (17) yields

$$\beta(s) = \sum_{k=0}^{\infty} kp(k) - \sum_{k=0}^{k=s} kp(k) - s \sum_{k=0}^{\infty} p(k) + s \sum_{k=0}^{k=s} p(k) \quad (18)$$

$$= \lambda T - \sum_{k=0}^{k=s} kp(k) - s + s \sum_{k=0}^{k=s} p(k)$$

$$= \lambda T - s + \sum_{k=0}^{k=s-1} (s-k)p(k)$$

$$= \lambda T - s + e^{-\lambda T} \sum_{k=0}^{k=s-1} (s-k)(\lambda T)^k/k! .$$

Thus, $\beta(0) = \lambda T$ and $\beta(1) = \lambda T - 1 + e^{-\lambda T} = \beta(0) - \alpha(0) + \gamma(0)$, where $\alpha(0) = 1$ and $\gamma(0) = e^{-\lambda T}$.

Equation (19) results from expanding equation (18) with $s+1$ being substituted for s

$$\beta(s+1) = \lambda T - (s+1) + e^{-\lambda T} \sum_{k=0}^{k=s} (s+1-k)(\lambda T)^k/k! \quad (19)$$

$$= \lambda T - s + e^{-\lambda T} \sum_{k=0}^{k=s-1} (s-k)(\lambda T)^k/k! - [1 - e^{-\lambda T} \sum_{k=0}^{k=s-1} (\lambda T)^k/k!] + e^{-\lambda T} (\lambda T)^s/s! .$$

Define $\alpha(s) = \alpha(s-1) - \gamma(s-1)$ and $\gamma(s) = \gamma(s-1) \lambda T/s$, then

$$\beta(s+1) = \beta(s) - \alpha(s) + \gamma(s)$$

The terms $\alpha(s)$ and $\gamma(s)$ are readily updated as the value of s is incremented by one. At each value of s , the quantity $\gamma(s-1)\lambda T/s$ is tested against the minimum permissible positive number for the computer, ϵ . A value below ϵ would cause "underflow"; thus, in the computer program

$$\gamma(s) = \begin{cases} \gamma(s-1)\lambda T/s & \text{if } \gamma(s)\lambda T/s > \epsilon; \\ 0 & \text{otherwise.} \end{cases}$$

Setting $\gamma(s)$ to zero when underflow would have occurred does not affect the value of $\beta(s+1)$ for most realistic situations since $\epsilon < 10^{-75}$ in typical scientific computer systems.

ACKNOWLEDGEMENT

ARIES was developed under USAF Contract F33657-72-C-1013 for the AGM-86A Program Office, AFSC, Aeronautical Systems Division, Wright-Patterson AFB, Ohio. The author wishes to express gratitude to Sol Kaufman for his review of the model and his comments that led to significant improvement in the approach and presentation.

REFERENCES

1. Brooks, R.B., Gillen, C.A., and Lu, J.Y., "Alternative Measures of Supply Performance: Fills, Backorders, Operational Rate, and NORS", RM-6094-PR, The RAND Corporation, August, 1969.
2. Everett, H., "Generalized Lagrange Multiplier Method for Solving Problems of Optimal Allocation of Resources:", *Opns. Res.*, Vol. II, No. 3, May-June 1965, pp. 399-417.
3. Feeney, G.J., and C.C.Sherbrooke, "The (s-1,s) Inventory Policy Under Compound Poisson Demand," *Management Sci.*, Vol. 12, No. 5, January, 1966, pp. 391-411; also published by the RAND Corporation, RM-4176-1-PR, March, 1966.
4. Fox, B.L., "Discrete Optimization Via Marginal Analysis", *Management Sci.*, Series A 13, pp. 210-216, November 1966.
5. Kaplan, R.J., Lu, J.Y., and Paulson, R.M., "SCAM: A System support Cost Analysis Model", RM-6049-PR, The RAND Corporation, November, 1969.
6. Miller, B.L., "A Multi-Item Inventory Model with Joint Backorder Criterion," *Opns. Res.*, Vol. 19, No. 6, October 1971, pp. 1467-76.

7. Rose, M., "The (S-1,S) Inventory Model with Arbitrary Back-Ordered Demand and Constant Times", *Opns. Res.*, Vol. 20, No. 5, September-October 1972, pp. 1020-32.
8. Sherbrooke, C.C., "METRIC: A Multi-Echelon Technique for Recoverable Item Control", RM-5078-PR, November 1966; also *Opns. Res.*, Vol. 16, No. 1, January - February 1968, pp. 122-141.
9. _____, "An Evaluator for the Number of Operationally Ready Aircraft in A Multilevel Supply System", *Opns. Res.*, Vol. 19, No. 3, May - June 1971, pp. 618 - 35.
10. Simon, R.M., "Stationary Properties of a Two-echelon Inventory Model for Low Demand Items", *Opns. Res.*, Vol. 19, No. 3, May - June 1971, pp. 761-73.
11. Vanarsdall, D.P., "Discussion of the ARIES (Aggregate Recoverable Item Evaluation System) Model and Computer Program", Report TA-5175-Q-18, Calspan Corporation, June, 1973.
12. Waina, R.B., Zacks, L.H., and May, D.D., "FSCAM: A Family of Support Cost Analysis Models", WN-7593-PR, The RAND Corporation, November, 1969.

Section V COMPUTER PROGRAM

This section presents a technical discussion of the computer program for the ARIES model. The topics discussed include: program logic organization, input data requirements, output displays, typical program usage, definition of variables, and computation techniques. The discussion centers around the version of the program that runs on the CDC 6600 computer at ASD. There is another, similar version of the ARIES program that is programmed for the IBM 370/165 computer.

PROGRAM LOGIC ORGANIZATION

ARIES is a large optimization system that is composed of submodels for performing specific computations. Therefore, to describe the analysis structure of the system, reference is made to Figure 4, which is an overview flow diagram of the system. The following discussion describes the input, logic, and output for each module.

Module 1 - MSCAM2

The Calspan MSCAM model has been modified (and, hereafter, denoted MSCAM2) to calculate for each item i , for each of the four alternative maintenance strategies, an appropriate range of expected backorders (BO) and the corresponding life cycle costs, LCC_i . The input data to Module 1 are essentially the same as the item input data to the MSCAM model. For each of the four maintenance strategies, there are decreasing values for the expected number of backorders as the LCC_i increases. The corresponding initial base-depot stockage levels are also determined as a result of the computation in Module 1.

Module 2 - Optimum Item BO-LCC Function

The inputs to Module 2 are the data points for the item BO-LCC functions for each of the four maintenance strategies. Module 2 collapses the four discrete BO-LCC functions to one optimum function for the item, $\{\zeta_{i,n}\}$. The

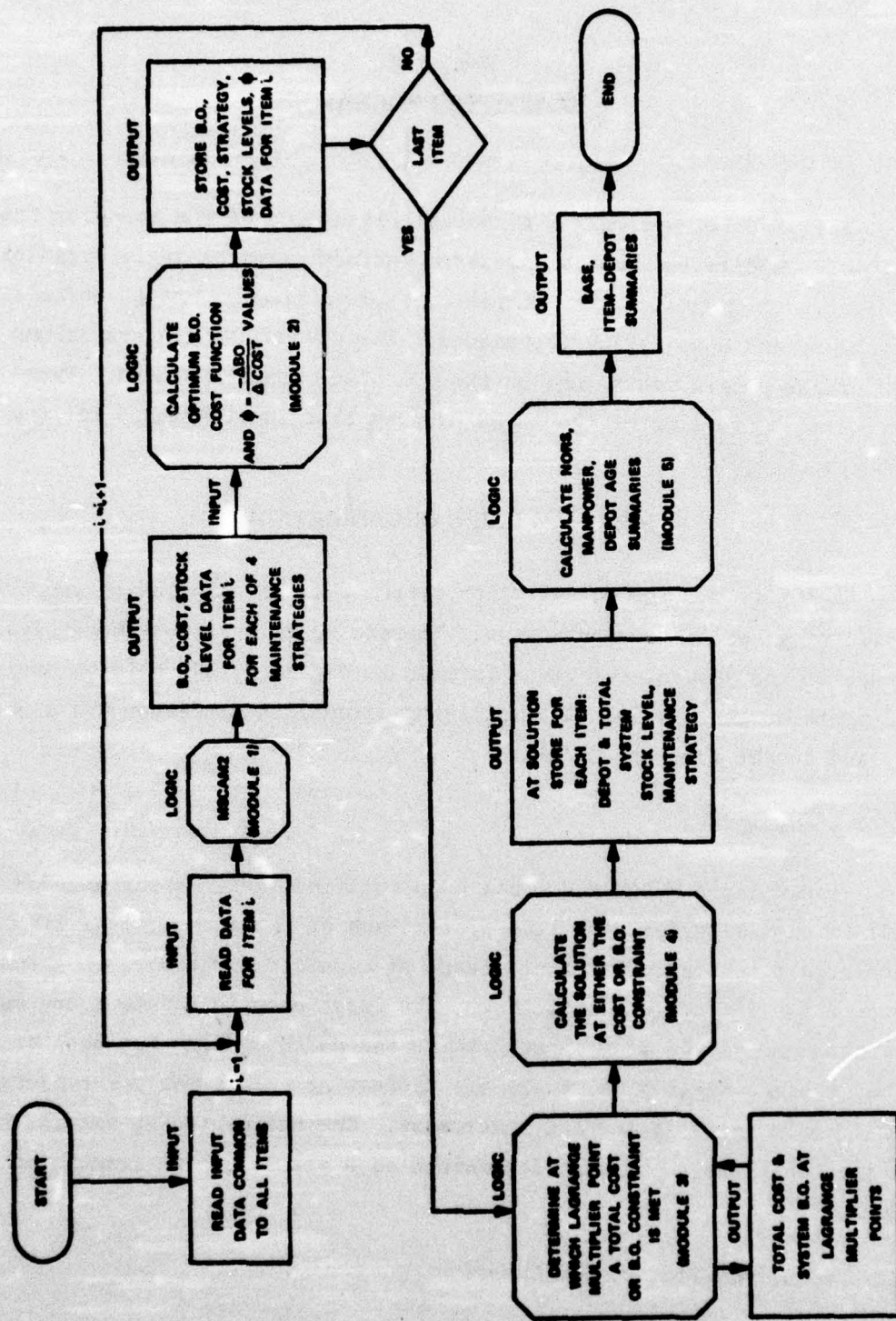

Fig. 4. ARIES Computer Program Overview Flow Diagram

resultant function defines the minimum cost (also, the maintenance strategy and the base-depot stock levels) corresponding to a given value for the item expected backorder sum.

After the $\{C_{i,n}\}$ function is computed, the ratio θ_i from equation (6) is calculated for each (BO, LCC_i) data point beyond the first. For those points that are not on the lower boundary of the convex hull, the value of θ_i is multiplied by -1 to convey a non-convexity signal and the θ_i value within one computer word. Using only those points on the lower convex hull boundary, the values of ϕ_i are computed using equation (5). The parameters θ_i and ϕ_i are used in Module 3 with the Lagrange multiplier and marginal allocation techniques. The output from Module 2 and the item input data are stored on random access disc for later usage.

Module 3 - Determination of the Region Where a Constraint is Met

Utilizing the principle of Lagrange multipliers, the smallest ϕ_i for item i that is equal to or greater than specified Lagrange multipliers λ_k , ($k = 1, 2, \dots, 15$) is noted $\phi_{i,k}$ and stored (with the corresponding $BO_{i,k}$ and $LCC_{i,k}$) for subsequent use in determining the total system expected backorders and LCC. For each λ_k , the total system expected backorder sum and LCC are computed by equations (20) and (21), respectively.

$$\begin{array}{l} \text{Total system} \\ \text{expected backorders} \end{array} = \sum_i BO_{i,k} \quad (20)$$

$$\begin{array}{l} \text{Total system} \\ \text{LCC} \end{array} = \sum_i LCC_{i,k} \quad (21)$$

Module 3 tests to determine between which two λ_k a constraint is met for either total LCC or total expected backorders, or both; call the two bounding Lagrange multipliers λ_{m-1} and λ_m . Module 3 prints out the total LCC and the total system expected backorders for each λ_k .

Module 4 - Compute Solution at Constraint

Once the region has been defined where either a cost or backorder constraint is met, the technique of marginal allocation is employed to reach the solution at the constraint. The following procedure is performed:

- (1) Initialize the sum of system backorders and total cost by summing the individual item backorders and cost at λ_p where $p = \max(1, m-1)$, and λ_m is where a constraint is met in Module 3.*
- (2) Using marginal allocation, select the item which has the largest ratio of marginal decrease in expected backorders divided by the marginal increase in LCC to obtain an expected backorder reduction (i.e., ϕ_i ; from equation (5)).
- (3) Test to see if a constraint would be violated: if yes, go to step (5); otherwise, go to step (4).
- (4) Update the total system backorders and cost by adding the additional unit of the item selected in step (2) to the system. If using ϕ_i , go to step (2); otherwise, go to step (5).
- (5) Using marginal allocation, select the item which has the largest θ_i value (i.e., from equation (6)).
- (6) Repeat steps (3) through (5) until there are no more feasible item allocations that can be added to the system with a constraint still not violated.

*The program actually has five different variations of the marginal allocation technique. (Refer to Section IV for the definitions and to Card Group IX (Table IV) for the input data format.)

The benefit of using the Lagrange multiplier technique in conjunction with marginal allocation is that a large reduction can be made in the number of calculations while a solution can be approached that is very close to optimal for the constraint.

Module 5 - Calculate Base and Item-Depot Summaries

The solution computed in Module 4 defines the item maintenance strategies $\{m_i; 1 \leq i \leq I\}$ and the base and depot stock levels $\{s_{ij}; \text{ for all } i \text{ and } j\}$. Using the item input data and the item problem solution data, modified versions of MSCAM-type submodels are employed to compute useful summary data for each base and also at the depot. Tables VI and VII (which appear later in this section) illustrate how the output data would be arranged for the base and item-depot summaries, respectively. The expected number of NORS missiles is computed for the case when complete cannibalization is assumed and for the case when there is no cannibalization.

Subroutine Structure

ARIES is composed of 17 subroutines. Figure 5 shows how the subroutines interface. Table III summarizes the function of each subroutine and gives its location in the program--i.e., overlay, overview logic module, and program execution section (discussed in the next subsection below).

Program Execution Sections and Disc Data Files

A convenient way to visualize the ARIES computer program is to consider the program as consisting of three execution sections. The first section processes the item data to generate the individual expected backorder-LCC functions, $\{S_{in}\}$. Section I corresponds to principal subroutines STOCK and CAL. The item data are stored on disc file 8 and can be treated as a permanent data file.

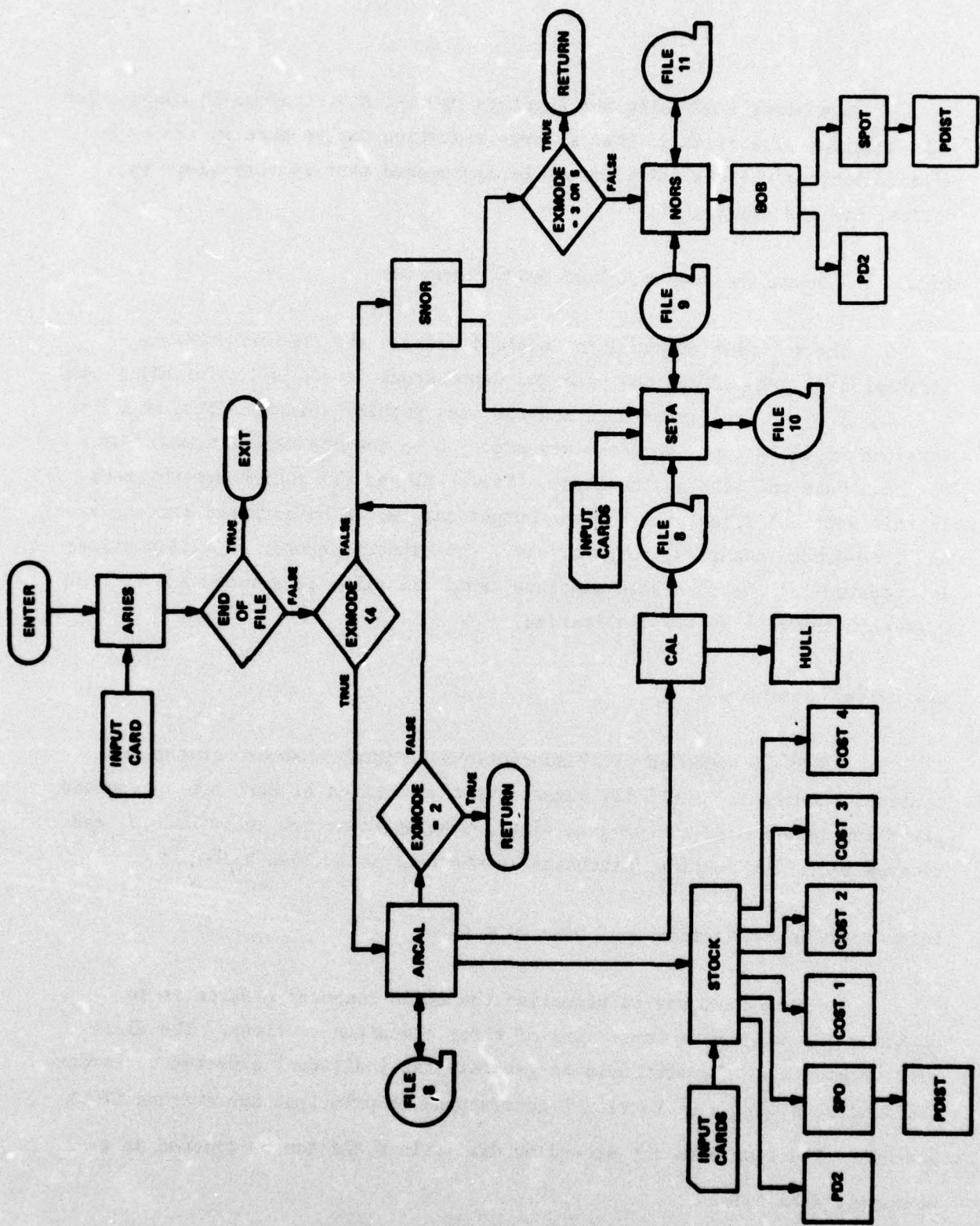

Fig. 5. Macro Flowchart of the ARIES Computer Program Subroutines

TABLE III
FUNCTIONAL DESCRIPTION OF ARIES SUBROUTINES

OVERLAY	SUBROUTINE	OVERVIEW LOGIC MODULE	PROGRAM EXECUTION SECTION	BRIEF DESCRIPTION OF FUNCTION
(ACSN, 0, 0)	ARIES	1	I, II, III	Main program control
	PDIST	1, 5	I, III	Compute expected backorders across all bases
	PD2	1, 5	I, III	Compute fraction of depot repair time delay
(ACSN, 1, 0)	ARCAL	1	I	Initialize File 8
	STOCK	1	I	Compute optimum combination of base-depot stock levels for a range of total stock values
	SPO	1	I	Compute diagonal of backorders for the base-depot stock allocation matrix
	COST1	1	I	Compute BD strategy LCC
	COST2	1	I	Compute D strategy LCC
	COST3	1	I	Compute B strategy LCC
	COST4	1	I	Compute NR strategy LCC
	CAL	2	I	Compute optimum item function $\{\xi_{in}\}$
	HULL	2	I	Compute convex item function $\{\xi_{ip}\}$
(ACSN, 2, 0)	SNOR	3	II, III	Program control for Sections II and III
	SETA	3, 4	II	Compute solution at Lagrange multiplier and constraint points
	NORS	5	III	Compute expected NORS and base, item-depot summaries
	BOB	5	III	Initialize parameters for subroutine SPOT calculations
	SPOT	5	III	Compute expected backorders for an item at each base

Execution Section II corresponds to subroutine SETA in the program. SETA reads file 8 twice. SETA generates two temporary disc files for intermediate calculations. File 9 is used to store the data from file 8 for the region where a constraint is met. File 10 is used to store the table of index values that define the individual item solutions for the fifteen Lagrange multiplier values.

Execution Section III corresponds to subroutines NORS, BOB, and SPOT. NORS reads file 9 once. NORS generates temporary file 11. File 11 is used to construct the output tables.

INPUT DATA

Table IV defines the ARIES input data requirements. The first data card defines the value of EXMODE and, hence, which sections of the program are to be executed.

<u>EXMODE</u>	<u>SECTIONS EXECUTED</u>
1	all
2	I only
3	I and II
4	II and III
5	II only
6	II and III

Whenever Section I is executed, a file 8 is either created (if there is no previous file 8) or extended with the data for new items that are under calculation with the current computer run. When there is no pre-existing file 8, set IOMODE to 0; when there is an existing file 8, set IOMODE to 1. If EXMODE equals 4, 5, or 6, a pre-existing file 8 is assumed.

EXMODE=6 differs from 4 by the fact that, with 6, the program assumes that a constraint problem has been solved prior to the case with EXMODE=6 (i.e., during the same computer run), with the same Lagrange multipliers, the same

TABLE IV
INPUT DATA FORMAT FOR THE ARIES MODEL

Card groups I through V are data that is common to all items.

Card Group I (1 card): Format (515, 2E10.4, 4, 15)

<u>Column</u>	<u>Format</u>	<u>Variable</u>	<u>Brief Explanation</u>
1-5	15	EXMODE	Execution option: 1 - execute entire program 2 - execute STOCK-CAL, do not execute SETA-NORS 3 - execute STOCK-CAL-SETA, do not execute NORS 4 - execute SETA-NORS, do not execute STOCK-CAL 5 - execute SETA only 6 - execute SETA-NORS and only after a constraint problem that used EXMODE = 3, 4, or 5
6-10	15	NITEMS	Number of items; ≤ 500 When IOMODE=1, NITEMS=number of items to be added to file 8
11-15	15	NBASE	Number of bases; ≤ 17
16-20	15	NDPTS	Number of depots; ≤ 5
21-25	15	NINP	Input device number; number of devices from which errors PROG, OST, DIST, XX, CODEA, and CODEB are to be read
26-35	E10.5	EPB1	A number $<$ last Lagrange Multiplier value; the minimum θ_j calculated for an item
36-45	E10.5	EPB2	Minimum backorder value that will be computed for each item backorder-cost function
46-50	15	IOMODE	Disk input option: 1 - File 8 is to be modified by the current run executing Section I 0 - There is no pre-existing file 8 to be modified

If EXMODE is 4, 5, or 6, skip to Card Group IX.

Card Group II (3 cards): Format (18A4)

<u>Column</u>	<u>Format</u>	<u>Variable</u>	<u>Brief Explanation</u>
1-72	18A4	FMT1	Format for writing XX(1) - XX(4), PWF
1-72	18A4	FMT2	Format for reading XX(5) - XX(31)
1-72	18A4	FMT3	Format for reading XX(1) to XX(4), PBAC, FRF, PWF

Card Group III (1 or 2 cards for each base): Format (7F10.3)

<u>Column</u>	<u>Format</u>	<u>Variable</u>	<u>Brief Explanation</u>
1-10	F10.3	PROG(I)	Total vehicle operating hours per month per base
11-20	F10.3	OST(I, J)	Order and shipping time associated with base I and depot J
21-30	F10.3	DIST(I, J)	Distance from base I to depot J
31-40	F10.3	OST(I, J)	Same as above
41-50	F10.3	DIST(I, J)	Same as above
51-60	F10.3	OST(I, J)	Same as above
61-70	F10.3	DIST(I, J)	Same as above

**TABLE IV (Cont.)
INPUT DATA FORMAT FOR THE ARIES MODEL**

Card Group III (Cont.)

Second Card (if required):

<u>Column</u>	<u>Format</u>	<u>Variable</u>	<u>Brief Explanation</u>
1-10	F10.3	OST(I, J)	Same as above
11-20	F10.3	DIST(I, J)	Same as above
21-30	F10.3	OST(I, J)	Same as above
31-40	F10.3	DIST(I, J)	Same as above

Card Group IV (2 cards): Format FMT3

<u>Format</u>	<u>Variable</u>	<u>Brief Explanation</u>
FMT3	PBAC(I)	For depot only and no repair strategies, the fraction of base AGE cost incurred for equipment type I; $1 \leq 7$
FMT3	FRF	Failure rate factor to multiple the input failure rate XX(21)
FMT3	PWF	10-Year uniform series present worth factor

Card Group V (1 card): FMT3

<u>Variable</u>	<u>Brief Explanation</u>
XX(1)	Base repair cost, \$ per man-hour
XX(2)	Depot repair cost, \$ per man-hour
XX(3)	Shipping cost, \$/ton/mile
XX(4)	Packaging cost, \$/shipment

Card Groups VI through VIII are repeated for each item.

Card Group VI (Usually 5 cards): Format FMT2

<u>Variable</u>	<u>Brief Explanation</u>
XX(5) to XX(7)	Item ID
XX(8)	Factor denoting the number of times the base repair man-hours exceed the base man-hours to detect/remove/replace an item (i.e., exceed XX(19))
XX(9)	Depot index corresponding to J in Card Group III
XX(10)	Number of end-item units per vehicle
XX(11)	AGE installation and set-up cost, \$
XX(12)	Number of pages of technical data
XX(13)	Annual operating and maintenance cost per AGE, \$
XX(14)	Cost of an end-item, \$
XX(15)	End-item shipping weight, lb

**TABLE IV (Cont.)
INPUT DATA FORMAT FOR THE ARIES MODEL**

Card Group VI (Cont.)

XX(16)	Expected NRTS rate; < 1.0
XX(17)	Condemnation rate; < 1.0
XX(18)	Average base repair turnaround time, days
XX(19)	Man-hours per job to detect/remove/replace at base
XX(20)	Man-hours per job to repair at depot
XX(21)	Failures per 100 effective operating hours
XX(22)	Weight of base AGE, lb/unit
XX(23)	Cost of depot AGE, \$/unit
XX(24)	Procurement lead time, days
XX(25)	Base repair parts cost, \$/repair
XX(26)	Depot repair parts cost, \$/repair
XX(27)	Number of base manpower skills; ≤ 9
XX(28)	Base AGE cost, \$/unit
XX(29)	Average depot repair turnaround time, days
XX(30)	Average hours/repair depot AGE is required
XX(31)	Equipment type index I corresponding to PBAC(I)

Card Group VII (1 card): Format (9(1X, 13, A2)

<u>Column</u>	<u>Format</u>	<u>Variable</u>	<u>Brief Explanation</u>
3-6	13, A2	Code A(1), Code B(1)	Base manpower skill codes
8-12	13, A2	Code A(2), Code B(2)	Base manpower skill codes
14-18	13, A2	Code A(3), Code B(3)	Base manpower skill codes
20-24	13, A2	Code A(4), Code B(4)	Base manpower skill codes
26-30	13, A2	Code A(5), Code B(5)	Base manpower skill codes
32-36	13, A2	Code A(6), Code B(6)	Base manpower skill codes
38-42	13, A2	Code A(7), Code B(7)	Base manpower skill codes
44-48	13, A2	Code A(8), Code B(8)	Base manpower skill codes
50-54	13, A2	Code A(9), Code B(9)	Base manpower skill codes

Card Group VIII (1 card): Format (9F5.2)

<u>Column</u>	<u>Format</u>	<u>Variable</u>	<u>Brief Explanation</u>
1-5	F5.2	PNTSKL(1)	Fraction of job repair man-hours per base manpower skill (e.g., inputs vary between 0 and 1)
6-10	F5.2	PNTSKL(2)	
11-15	F5.2	PNTSKL(3)	
16-20	F5.2	PNTSKL(4)	
21-25	F5.2	PNTSKL(5)	
26-30	F5.2	PNTSKL(6)	
31-35	F5.2	PNTSKL(7)	
36-40	F5.2	PNTSKL(8)	
41-45	F5.2	PNTSKL(9)	

**TABLE IV (Cont.)
INPUT DATA FORMAT FOR THE ARIES MODEL**

Card Group IX (2 cards): Format (2E15.7, 415/2014)

<u>Column</u>	<u>Format</u>	<u>Variable</u>	<u>Brief Explanation</u>
1-15	G15.7	DMAX	Cost constraint
16-30	G15.7	EPS	Backorder constraint
31-35	I5	MP	Maximum number of data points per item on file 8; ≤ 300
36-40	I5	DLETNO	Number of items residing on file 8 that are to be deleted from the current execution of SETA; ≤ 10
41-45	I5	IOPT	Allocation algorithm; IOPT = 1, 2, 3, 4, or 5. See Section IV for definitions. Generally, IOPT = 3 is used.
46-50	I5	IZ	For IZ=IOPT, base summaries are printed out For IZ \neq IOPT, base summary printout is suppressed

Second card:

<u>Column</u>	<u>Format</u>	<u>Variable</u>	<u>Brief Explanation</u>
1-4	I4	NV(1)	Number of vehicles at base 1
5-8	I4	NV(2)	Number of vehicles at base 2
9-12	I4	NV(3)	Number of vehicles at base 3
.	.	.	.
.	.	.	.
65-68	I4	NV(17)	Number of vehicles at base 17

Card Group X (3 cards): Format (5G15.7)

<u>Column</u>	<u>Format</u>	<u>Variable</u>	<u>Brief Explanation</u>
1-15	G15.7	LM(1)	Lagrange multiplier values in strictly monotonically decreasing order
16-30	G15.7	LM(2)	
31-45	G15.7	.	
46-60	G15.7	.	
61-75	G15.7	.	

If DLETNO is zero, deck is complete and, thus, Card Group XI is skipped

Card Group XI (1 card for each item deleted): Format (3A4)

<u>Column</u>	<u>Format</u>	<u>Variable</u>	<u>Brief Explanation</u>
1-12	3A4	(DELET (I, J), I = 1, 3)	Item-ID of item residing on file 8 to be deleted from current execution of SETA and NORS

End of DATA DECK

number of vehicles per base, and the same items that are going to be used for the current constraint problem.

For the CDC 6600 computer, the control card "CATALOG, TAPE8, ARIES, CY = RP = 999." is used to retain the original generation of a file 8. The control card "EXTEND, TAPE8." is used to extend a pre-existing file 8 with modified item data or additional item data and to retain it permanently.

The capability exists to suppress items on file 8 from the optimization calculations in Section II and III by use of the input variables DLETNO and DELET. The parameter DLETNO (Card Group IX) indicates the number of records of file 8 that are to be deleted; the item-IDs of the items to be deleted are placed in array DELET (Card Group XI). A maximum of ten items from file 8 may be deleted on a given computer run.

Unlike the modifications which result from extending file 8, use of DLETNO and DELET does not cause a "physical" change in file 8 (i.e., there are no records actually removed from the file). The actual effect is that records with item-IDs appearing in DELET are ignored during the current calculations in SETA; they remain in file 8 and are accessible for subsequent executions of SETA.

TYPICAL PROGRAM USAGE

ARIES is written in extended FORTRAN IV language. The program uses 106₈K central memory words and takes approximately 18 seconds to compile. The central processor time to generate the item expected backorder-LCC functions for the example problem discussed in Section IV is approximately 90 seconds. It takes 0.062 seconds of c.p. time to execute Sections II and III of the program for a constraint in the example problem; the I/O time is approximately 31 seconds. The I/O time is relatively high, since the CDC algorithm for disc I/O time incorporates a large fixed time for each instance in which the disc is called in addition to the variable time relating to the number of words transferred.

A typical way to use ARIES would be to generate file 8 with EXMODE=1, a low backorder constraint, and a cost constraint that would likely fall within the range of the data for the 15 Lagrange multiplier points. Upon examining the output, note the upper and lower limits of the total system LCC for the range of 15 Lagrange multipliers. Using EXMODE=4 for the first constraint and EXMODE=6 thereafter, submit another run with sets of data for total cost constraints spaced over the noted cost interval to derive the curve for expected NORS (availability measurement) versus LCC. The program is written to execute new data sets until an end-of-file card is encountered.

The item input data cards (Card Groups V through VIII) are same as those for the Calspan version of the MSCAM model with the exception that XX(9) for MSCAM is the "expected sum of item backorders across all bases" instead of the "depot index corresponding to J in Card Group III." This high degree of commonality facilitates continuity of operation between the two models.

DEFINITION OF VARIABLES

Since ARIES is a large program, it would be too voluminous to define here each FORTRAN variable. Table V presents some of the principal variable definitions, along with their locations in the program. The input data requirements (Table IV) also define program variables.

OUTPUT DISPLAYS

ARIES is written to print out several formal tables and several intermediate calculations which are helpful for checking that the results are logical and consistent. The content of two of the formal tables is illustrated by Tables VI and VII, which show the base and item-depot summaries, respectively.

In each table, the term "Not Operationally Ready - Supply" (NORS) is listed. For the base summary output table, the expected number of NORS missiles attributable to a particular item is defined to be the expected back-order value, divided by the number of units of that item which are used on a

TABLE V
DEFINITIONS OF SOME OF THE VARIABLES APPEARING IN ARIES

FORTRAN NAME	DEFINITION	EXECUTION SECTION
EXMODE	Execution option parameter	I, II
NITEMS	Number of items	all
NBASE	Number of bases	all
NDPTS	Number of depots	all
NINP	Input device number	I
EPS1	Control to stop calculations in STOCK	I
EPS2	Control to stop calculations in STOCK	I
IOMODE	Disk input option parameter	I
PROG(I)	Total base operating hours per month	all
OST(I, J)	Order and shipping time	all
DIST(I, J)	Distance from base I to depot J	all
BRCST, XX(1)	Base repair cost, \$ per man-hour	I
DRCST, XX(2)	Depot repair cost, \$ per man-hour	I
SHPCST, XX(3)	Shipping cost/ton/mile, \$	I
PAKCST, XX(4)	Packaging cost/shipment, \$	I
SETCST, XX(11)	Installation and AGE setup cost	I
DATCST, XX(12)	Number of pages of technical data	I
OPCST, XX(13)	Annual operating and maintenance cost per unit AGE	I
ENDCST, XX(14)	Cost of end-item	I
ENDWT, XX(15)	Shipping weight of end-item	I
EXNRTS, XX(16)	Expected NRTS rate	I, III
CNDMX, XX(17)	Condemnation rate	I, III
BRTIME, XX(18)	Average base repair time, days	I, III
BMANHR, XX(19)	Man-hours per job to fix at base	I, III
DMANHR, XX(20)	Man-hours per job to fix at depot	I, III
FAILRT, XX(21)	Failures per 100 effective operating hours	I, III
BAGEWT, XX(22)	Weight of base-AGE	I
DAGCST, XX(23)	Cost of depot-AGE	I
DLDTME, XX(24)	Procurement lead time	I, III
BPTCST, XX(25)	Repair parts cost at base	I
DPTCST, XX(26)	Repair parts cost at depot	I
NSKIL, XX(27)	Number of different skills to repair this item at base	I, III
BAGCST, XX(28)	Cost of base-AGE	I
DRTIME, XX(29)	Average repair time at depot	I, III
DAGEHR, XX(30)	Average hr/repair Depot AGE is required	I, III
NITS	Number of items to be processed by SETA-NORS	II, III
ITEM	Index no. for ARCAL do loop	I

TABLE V (cont.)

DEFINITIONS OF SOME OF THE VARIABLES APPEARING IN ARIES

FORTRAN NAME	DEFINITION	EXECUTION SECTION
CODEA(1), CODEB(1)	Labor skill codes symbols	I, III
PNTSKL	Percentage repair per labor skill	I, III
DEMLT	Average demand during lead time	I, III
BOF(J), J = 1, 2	Backorders at random point in time; BOF(1) is backorders with one less unit of stock than BOF(2)	I, III
BOD(J)	Average delay at depot given depot stock (J-1)	I, III
MP	Upper limit for item total stock	all
M	MP-1	I
DIST(I, J)	Distance (miles) between depot J and base I	I
GS(J, 1)	Sum of base level stock for case J = 1, ..., 4	I
GS(J, 2)	Depot stock level for case J = 1, ..., 4	I
BO	Backorder array as returned by STOCK	I
C	Cost array as returned by STOCK	I
BNJ	Backorder array as returned by CAL	I, II
DNJ	Cost array as returned by CAL	I, II
BNJSTR	Backorder array passed from SETA to NORS	II, III
DNJSTR	Cost array passed from SETA to NORS	II, III
BKOR	Backorder array as returned from BOB	III
BB(I)	Backorder array at base I as returned from SPOT	III
KNJ	Maintenance strategy array	I, II
PHI	ϕ array	I, II
NDX	Index counter for file 8	I, II
REC	Index counter for file 8 record number	I, II
ZZ	Current value of minimum cost that satisfies θ_1 and θ_2	I
T	Diagonal array of backorders from the base-depot allocation matrix	I
NB(I, L)	Number of units of stock at base I for L-1 total units of stock	I
TABLE	Array with ID-names of the items on file 8	I, II
BT(K)	Total expected backorders at Lagrange multiplier K	II
LCC(K)	Total LCC at Lagrange multiplier K	II
XBT	Total expected backorders at constraint point	II
XLCC	Total LCC at constraint point	II
KJ(K)	Index counter denoting the position on file 8 where a Lagrange multiplier point is met for the item under current calculation	II
ENORS	Expected NORS assuming cannibalization	III
EN	Expected NORS assuming no cannibalization	III
XMNYR(K)	Number of man-years for labor skill K	I, III

TABLE VI
SAMPLE OUTPUT FORMAT FOR THE ARIES BASE SUMMARY DATA
SUMMARY FOR BASE _____

ITEM	STOCK LEVEL	STRATEGY	BACKORDER	NORS*	MANPOWER
1 SUM	6	BD	0.653	0.327	3.257
SKILL A					1.056
SKILL B					0.087
SKILL C					2.114
SKILL D					
SKILL E					
2 SUM	5	B	0.764	0.764	4.672
SKILL A					2.672
SKILL B					2.000
•		•			•
•		•			•
•		•			•
500 SUM	9	BD	0.564	0.282	2.541
SKILL A					2.541
TOTAL	2186		6.573	0.764**	28.456

* Not Operationally Ready-Supply
 ** Maximum item NORS value; corresponds to the complete cannibalization case

TABLE VII
SAMPLE OUTPUT FORMAT FOR THE ARIES ITEM-DEPOT SUMMARY DATA

ITEM AND DEPOT(S) SUMMARY

ITEM NO.	STOCK LEVELS			STRATEGY	EXPECTED BACKORDERS	EXPECTED NORS INDEX	DEPOT MANPOWER	NO. OF DEPOT AGE	TOTAL LOCC(M), \$
	DEPOT	BASES	TOTAL						
1	44	52	96	BD	2,066	1,028	3,201	1.	\$168,566.
2	35	105	140	B	1,763	1,763	2,746	7.	75,968.
•					•				•
•					•				•
•					•				•
500	37	96	123	BD	2,182	1,091	1,872	2.	97,836.
TOTAL	1,905	2,480	4,285		54,721	35,863*	98,456	425.	\$65,865,427.

• Sum of expected NORS at all bases; corresponds to the complete cannibalization case.

missile. The number of NORS missiles for each base is equal to the maximum value for an "item NORS" when parts are consolidated through the practice of cannibalization. NORS missiles will be constrained by the item in shortest supply. The expected NORS index for each item listed in the item-depot summary is the item expected backorder value, divided by the number of units of the item that are used on the missile. The expected NORS value listed at the bottom of the table is the sum of the maximum expected NORS values from all bases (the sum of the "total" NORS from the base summaries).

The value for expected NORS missiles assuming no cannibalization is also computed and printed out separately.

A table is printed out to define the index counter value for the BO-LCC function for the solution for each item at each Lagrange multiplier point. This table provides a useful indication of how the item stockage levels are distributed over the range of system expenditure levels.

A table is printed out to show the total system expected backorders and the LCC for each of the 15 Lagrange multiplier points. This table is useful for determining how total cost constraints should be set to derive the total expected NORS versus total LCC function.

COMPUTATION TECHNIQUES

This subsection discusses some of the special computation techniques that are employed in the ARIES program.

Subroutines STOCK and SPO

For each item, the BO-LCC function must be computed for each of the four alternative maintenance strategies. SPO computes the diagonal of a matrix, (a_{kp}) , where each element a_{kp} is an optimal allocation of k units of stock among all the bases and p units of stock at the depot. The a_{kp} allocation is performed by iteratively selecting the next unit of stock for a base that

will maximize the reduction in the sum of expected backorders at all the bases. STOCK searches the diagonal of constant total stock (i.e., $k+p = \text{constant}$) for the base-depot stockage level combination that will provide the minimum expected backorder sum. The program terminates the calculations for an item maintenance strategy when any of the following conditions are satisfied:

- (1) The strategy under current calculation is the first one for the item (i.e., base-depot), and the expected backorder value is $\leq \epsilon_1$, and $\phi_i \leq \epsilon_2$, where ϵ_1 and ϵ_2 are input parameters; or
- (2) The total number of units of stock > 300 ; or
- (3) The strategy under calculation is not the first one (i.e., it is D, B, or NR), and there is a previously calculated strategy that has a maximum LCC (at the point of satisfying ϵ_1 and ϵ_2) which is lower than the current value for LCC for the strategy under computation. Stated analytically, there is a point beyond which the strategy is dominated by at least one other strategy.

Subroutines PDIST and PD2

An efficient recursive computational technique is used in PDIST and PD2 to compute the expected backorder values. This procedure is discussed in the appendix of Section IV.

Subroutine HULL

The basic procedure employed to derive the convexified item expected backorder-LCC function, $\{\xi_{i,p}'\}$, involves the iterative testing (starting from the leftmost point) to see where the next point to the right lies that has the minimum slope between it and the last point found on the convex hull. If the

point found is not adjacent, then a concave region exists; this region is identified in the program by multiplying the ϕ_i in this region by -1.

PROGRAM CHECKOUT

The ARIES computer program was checked out with two extensive test cases. The first test case is the example problem discussed in Section IV. The input data and sample output displays for this test case are given in Supplement A.

The second test case involved SRUs that have more than one unit used per missile (i.e., $u_i > 1$ for some i). The input data and sample output displays for this test case are presented in Supplement B.

Supplement A

EXAMPLE PROBLEM INPUT AND OUTPUT DATA

This supplement presents the input data and sample output displays for the example problem discussed in Section IV.

INPUT DATA

The input data for the example problem are summarized below.

Card Group I

EXMODE=1	NDPTS=1	EPS2=2.5x10 ⁻²
NITEMS=16	NINP=5	IOMODE=0
NBASE=17	EPS1=5x10 ⁻⁸	

Card Group II

(6F10.2)
(3A4/(6F10.0))
(7F10.2)

Card Group III

<u>I</u>	<u>PROG(I)</u>	<u>OST(I,1)</u>	<u>DIST(I,1)</u>
1	490.	25.	850.
2	490.	25.	900.
3	490.	25.	850.
4	490.	25.	700.
5	252.	25.	1500.
6	252.	25.	1100.
7	252.	25.	250.
8	252.	25.	250.
9	490.	25.	800.
10	490.	25.	700.
11	252.	25.	1200.
12	252.	25.	750.
13	490.	25.	1200.
14	490.	25.	600.
15	252.	25.	400.
16	252.	25.	900.
17	252.	25.	1200.

Card Group IV

<u>1</u>	<u>1</u>	<u>2</u>	<u>3</u>	<u>4</u>	<u>5</u>
PBAC(I)	0.90	0.95	0.10	0.20	0.05

FRF=3. ; PWF = 10.

Card Group V

<u>1</u>	<u>1</u>	<u>2</u>	<u>3</u>	<u>4</u>
XX(I)	11.	22.	0.5	200.

Card Group VI

See Table VIII

Card Groups VII and VIII

100AA }
1.0 } for each item

Card Group IX

D_{MAX} = 93.5x10⁶, 94x10⁶, ..., 110x10⁶; D_{MAX} is varied for each new constraint problem.

EPS = 1.0, MP = 300; DLETNO = 0; IOPT = 3; IZ = 0

<u>I</u>	<u>NV(I)</u>	<u>I</u>	<u>NV(I)</u>	<u>I</u>	<u>NV(I)</u>	<u>I</u>	<u>NV(I)</u>
1	70	6	36	10	70	14	70
2	70	7	36	11	36	15	36
3	70	8	36	12	36	16	36
4	70	9	70	13	70	17	36
5	36						

TABLE VIII
EXAMPLE PROBLEM INPUT DATA FOR THE XX-ARRAY (CARD GROUP VI)

VARIABLE	ITEM															
	1	2	3	4	5	6	7	8	9	10	11	12	13	14	15	16
XX(8) to XX(7)	ITEM 1	ITEM 2	ITEM 3	ITEM 4	ITEM 5	ITEM 6	ITEM 7	ITEM 8	ITEM 9	ITEM 10	ITEM 11	ITEM 12	ITEM 13	ITEM 14	ITEM 15	ITEM 16
XX(8)	5	5	5	5	5	5	5	5	5	5	5	5	5	5	5	5
XX(9)	1	1	1	1	1	1	1	1	1	1	1	1	1	1	1	1
XX(10)	1	1	1	1	1	1	1	1	1	1	1	1	1	1	1	1
XX(11)	584	504	504	504	504	504	504	582	2208	2208	1471	1471	1471	1471	1471	1471
XX(12)	38	38	38	38	38	38	38	38	180	180	67	67	67	67	67	67
XX(13)	3886	3886	3886	3886	3886	3886	3886	3886	6800	17000	11333	11333	11333	11333	11333	11333
XX(14)	63789	3880	7300	2400	14700	12200	6100	33800	31650	31650	12800	15800	63500	64700	65800	15000
XX(15)	970	34	85	80	73	46	113	156	37	37	21	15	50	46	38	10
XX(16)	.15	.15	.15	.15	.15	.15	.15	.15	.25	.25	.15	.15	.15	.15	.15	.15
XX(17)	.01	.01	.01	.01	.01	.01	.01	.05	.01	.01	.01	.01	.01	.01	.01	.01
XX(18)	10	10	10	10	10	10	10	10	10	10	10	10	10	10	10	10
XX(19)	6	6	6	6	6	6	6	7.5	9	9	6	6	6	6	6	6
XX(20)	180	180	180	180	180	180	180	100	135	135	80	80	80	80	80	80
XX(21)	.027	.027	.027	.027	.027	.027	.027	.186	.117	.117	.083	.083	.083	.083	.083	.083
XX(22)	57	57	57	57	57	57	57	100	250	250	167	167	167	167	167	167
XX(23)	100000	100000	100000	100000	100000	100000	100000	100000	500000	500000	117000	117000	117000	117000	117000	117000
XX(24)	180	180	180	180	180	180	180	180	180	180	180	180	180	180	180	180
XX(25)	1274	72	146	48	294	244	122	678	633	633	256	316	1270	1294	1312	300
XX(26)	1147	65	131	43	285	220	110	610	570	570	230	284	1143	1165	1181	270
XX(27)	1	1	1	1	1	1	1	1	1	1	1	1	1	1	1	1
XX(28)	38857	38857	38857	38857	38857	38857	38857	68000	170000	170000	113333	113333	113333	113333	113333	113333
XX(29)	42	42	42	42	42	42	42	42	42	42	42	42	42	42	42	42
XX(30)	12	12	12	12	12	12	12	1	12	12	20	20	20	20	20	20
XX(31)	4	4	4	4	4	4	4	3	2	2	1	1	1	1	1	1

Card Group X

<u>I</u>	<u>LM(I)</u>	<u>I</u>	<u>LM(I)</u>	<u>I</u>	<u>LM(I)</u>
1	9.16227766x10 ⁻¹	6	6.309573445x10 ⁻⁶	11	1.995262315x10 ⁻⁶
2	1.99526231x10 ⁻⁵	7	5.011872336x10 ⁻⁶	12	1.584893192x10 ⁻⁶
3	1.258925412x10 ⁻⁵	8	3.981071706x10 ⁻⁶	13	1.0x10 ⁻⁶
4	1.x10 ⁻⁵	9	3.16227x10 ⁻⁶	14	6.630957x10 ⁻⁷
5	7.943282347x10 ⁻⁶	10	2.51186x10 ⁻⁶	15	3.162278x10 ⁻⁷

Card Group XI

Not needed for this problem.

SAMPLE OUTPUT DISPLAYS

Table IX, X, and XI show sample printout displays for the example problem. Table IX shows the total system sum of expected backorders and LCC corresponding to the 15 Lagrange multipliers.

TABLE IX
TOTAL SYSTEM SUM OF EXPECTED BACKORDERS AND LCC
FOR THE EXAMPLE PROBLEM

<u>K</u>	<u>LAMBDA(K)</u>	<u>BT(K)</u>	<u>LCC(K)</u>
1	.8162278E+01	.1526232E+03	.9349321E+08
2	.1995252E-04	.8171959E+02	.9517979E+08
3	.1258925E-04	.5761964E+02	.9665153E+08
4	.1000000E-04	.4319078E+02	.9733556E+08
5	.7943282E-05	.4034299E+02	.9820220E+08
6	.6309573E-05	.2518840E+02	.1003501E+09
7	.5011872E-05	.2345794E+02	.1006497E+09
8	.3981072E-05	.1532369E+02	.1025260E+09
9	.3162278E-05	.1338597E+02	.1030477E+09
10	.2511886E-05	.1074207E+02	.1040251E+09
11	.1995262E-05	.8178189E+01	.1052560E+09
12	.1584893E-05	.5774326E+01	.1068334E+09
13	.1000000E-05	.3499816E+01	.1079692E+09
14	.6309573E-06	.2769050E+01	.1088624E+09
15	.3162278E-06	.8754258E+00	.1129705E+09

Table X is a tabulation of the KJ variable for each item for each of the 15 Lagrange multipliers. KJ is an index counter corresponding to π_i for item i in Equation (6). Thus, KJ reflects the sequence number for the original item functions $\{f_{i,n}\}$ that represent the item solution at each Lagrange multiplier value. The value of KJ is often close to representing to total number of units of stock for the item that is allocated between the bases and the depot; however, it may be different when the item maintenance strategy changes as the item resource expenditure level is increased.

Table XI shows the item and depot(s) summary printout for a LCC constraint of \$98 M.

TABLE X
SAMPLE PRINTOUT OF THE KJ-ARRAY FOR THE EXAMPLE PROBLEM

	LAGRANGE MULTIPLIER NUMBER															
	1	2	3	4	5	6	7	8	9	10	11	12	13	14	15	
FOR ITEM 1	1	1	1	1	1	1	1	2	2	9	10	10	18	14	15	
FOR ITEM 2	1	22	22	23	23	24	24	30	31	31	10	10	40	40	19	
FOR ITEM 3	1	9	10	19	18	18	19	19	19	19	31	27	27	27	41	
FOR ITEM 4	1	67	48	49	49	49	56	55	56	57	57	65	65	66	36	
FOR ITEM 5	1	1	2	3	10	10	18	18	18	19	19	19	19	27	72	
FOR ITEM 6	1	2	9	10	10	18	18	18	19	19	19	19	26	27	27	
FOR ITEM 7	1	10	18	19	18	19	19	19	19	19	26	27	27	27	36	
FOR ITEM 8	1	13	23	30	31	32	32	33	47	48	49	49	51	65	67	
FOR ITEM 9	1	7	15	24	24	31	32	33	33	34	42	48	50	51	65	
FOR ITEM 10	1	7	15	24	24	31	32	33	33	34	42	48	50	51	65	
FOR ITEM 11	1	20	21	29	28	29	29	30	30	38	39	45	46	47	48	
FOR ITEM 12	1	12	20	21	28	29	29	29	30	30	38	39	45	46	47	
FOR ITEM 13	1	1	2	3	3	11	12	20	20	21	28	28	29	30	45	
FOR ITEM 14	1	1	2	3	3	11	11	20	20	21	21	28	29	30	45	
FOR ITEM 15	1	1	2	3	3	11	11	20	20	21	21	28	29	30	45	
FOR ITEM 16	1	12	21	21	28	28	29	29	30	38	38	45	46	46	47	

TABLE XI
ITEM AND DEPOT(S) SUMMARY PRINTOUT DISPLAY FOR THE EXAMPLE PROBLEM
 (The solution is for a LCC constraint of \$98 M.)

ITEM ID.	STOCK LEVELS		STRATEGY	ITEM AND DEPOT(S) SUMMARY		DEPOT MANPOWER	NO. OF DEPOT AGE	TOTAL LCC(M), \$
	DEPOT	TOTAL		EXPECTED RECORDERS	EXPECTED NOXS INVEY			
ITEM 1	1	0	F1	2,449	2,449	1,249	1.	2374011.
ITEM 2	6	17	F1	.174	.174			2047709.
ITEM 3	1	17	F0	.194	.194	1,249	1.	2336733.
ITEM 4	7	17	F1	.150	.150			1902552.
ITEM 5	2	8	F0	.904	.904	1,249	1.	2415606.
ITEM 6	2	9	F0	.904	.904	1,249	1.	2357713.
ITEM 7	1	17	F0	.184	.184	1,249	1.	2278643.
ITEM 8	6	25	F0	2,960	2,960	5,473	1.	10936340.
ITEM 9	7	17	F0	3,279	3,279	8,116	1.	1271293.
ITEM 10	7	17	F1	3,279	3,279	9,116	1.	1271293.
ITEM 11	4	25	F0	.613	.613	2,294	1.	6506405.
ITEM 12	4	17	F0	1,600	1,600	2,294	1.	6597770.
ITEM 13	3	0	F0	9,123	9,123	2,294	1.	8553416.
ITEM 14	3	0	F0	9,123	9,123	2,294	1.	860261.
ITEM 15	3	0	F0	9,123	9,123	2,294	1.	8653475.
ITEM 15	4	17	F0	1,600	1,600	2,294	1.	6543339.
TOTAL	61	202		42,549	8,1238	41,711	14.	97999358.

#SUM OF EXPECTED NOXS AT ALL BASES (FOR THE COMPLETE CANNIBALIZATION CASE)

Supplement B

TEST CASE WITH SOME SRUs THAT REQUIRE MORE THAN ONE UNIT PER VEHICLE

This supplement presents the input data, solution results summary, and sample output displays for a model test case that has some SRUs that require more than one unit per vehicle.

INPUT DATA

The input data for this test case are summarized below.

Card Group I

EXMODE=1 NDPTS=3 ESP2=0.025
NITEMS=15 NINP=1 IMODE=0
NBASE=17 ESP1=5x10⁻⁶

Card Group II

(5F10.2)
(3A4/F12.0, 2F4.0, 6F10.2/7F10.2/8F10.2)
(7F10.2)

Card Group III

<u>I</u>	<u>PROG(I)</u>	<u>OST(I,1)</u>	<u>DIST(I,1)</u>	<u>OST(I,2)</u>	<u>DIST(I,2)</u>	<u>OST(I,3)</u>	<u>DIST(I,3)</u>
1	160	25	850	30	900	20	800
2	160	25	900	30	1000	20	3000
3	160	25	850	30	1000	20	450
4	160	25	700	30	800	20	700
5	160	25	1500	30	700	20	800
6	160	25	1100	30	600	20	900
7	160	25	250	30	2000	20	700
8	160	25	250	30	1000	20	800
9	160	25	800	30	1500	20	900
10	160	25	750	30	600	20	700
11	160	25	1200	30	800	20	1200
12	160	25	750	30	700	20	1000
13	160	25	1200	30	1000	20	800
14	160	25	600	30	500	20	700
15	160	25	600	30	1000	20	900
16	160	25	900	30	1200	20	500
17	160	25	1200	30	900	20	1100

Card Group IV

<u>I</u>	<u>1</u>	<u>2</u>	<u>3</u>	<u>4</u>	<u>5</u>
PBAC(I)	0.95	0.5	0.2	0.8	0.1

FRF=2. ; PWF=10.

Card Group V

<u>I</u>	<u>1</u>	<u>2</u>	<u>3</u>	<u>4</u>
XX(I)	9.	22.	.5	100.

Card Group VI

See Table XII

Card Groups VII and VIII

100AA } for each item
1.0 }

Card Group IX

DMAX=71.x10⁶, ..., 89x10⁶; DMAX is varied for each new constraint problem.

EPS = 1.0; MP = 300; DLETNO = 0; IOPT = 3; IZ = 0;

NV(I) = 60 for I = 1, 2, ..., 17

Card Group X

<u>I</u>	<u>LM(I)</u>	<u>I</u>	<u>LM(I)</u>	<u>I</u>	<u>LM(I)</u>
1	9.16227766x10 ⁻¹	6	6.309573445x10 ⁻⁶	11	1.995262315x10 ⁻⁶
2	1.99526231x10 ⁻⁵	7	5.011872336x10 ⁻⁶	12	1.584893192x10 ⁻⁶
3	1.258925412x10 ⁻⁵	8	3.981071706x10 ⁻⁶	13	1.0x10 ⁻⁶
4	1.x10 ⁻⁵	9	3.16227x10 ⁻⁶	14	6.630957x10 ⁻⁷
5	7.943282347x10 ⁻⁶	10	2.51186x10 ⁻⁶	15	3.162278x10 ⁻⁷

TABLE XII
TEST CASE (WITH SOME $u_i > 1$) INPUT DATA FOR THE XX-ARRAY (CARD GROUP VI)

VARIABLE	ITEM														
	1	2	3	4	5	6	7	8	9	10	11	12	13	14	15
XX(6) to XX(17)	ITEM 1	ITEM 2	ITEM 3	ITEM 4	ITEM 5	ITEM 6	ITEM 7	ITEM 8	ITEM 9	ITEM 10	ITEM 11	ITEM 12	ITEM 13	ITEM 14	ITEM 15
XX(8)	3	3	3	3	3	3	3	3	3	3	3	3	3	3	3
XX(9)	1	1	1	1	2	3	3	1	2	1	3	1	2	1	2
XX(10)	1	1	1	4	2	1	2	1	2	1	2	1	2	1	1
XX(11)	3000	3000	50000	900	1000	5000	5000	5000	6000	6000	1200	900	1000	2000	500
XX(12)	130	130	150	100	100	120	150	150	200	150	150	120	100	150	150
XX(13)	1300	1300	5000	500	1500	2000	5000	10000	20000	900	1200	600	2000	900	500
XX(14)	1800	12000	50000	25000	50000	40000	35000	80000	60000	30000	2000	4000	40000	90000	5000
XX(15)	5000	5000	800	300	250	300	500	300	400	100	600	700	100	400	100
XX(16)	.15	.15	.10	.05	.1	.2	.2	.3	.25	.2	.2	.1	.1	.2	.1
XX(17)	.1	.1	.05	.02	.05	.02	.05	.05	.05	.1	.1	.05	.05	.05	.05
XX(18)	40	15	20	8	30	8	10	20	20	15	60	5	15	20	5
XX(19)	20	50	20	10	60	20	30	40	30	30	20	8	20	15	8
XX(20)	20	20	40	20	160	60	60	100	80	40	40	50	40	60	40
XX(21)	.05	.10	.15	.05	.1	.15	.1	.05	.1	.3	.15	.25	.1	.2	.3
XX(22)	3000	3000	2000	2000	1000	600	1000	1000	600	300	2000	200	200	700	300
XX(23)	500000	800	50000	19000	50000	50000	50000	60000	50000	60000	300000	500000	50000	50000	500000
XX(24)	130	130	180	180	180	180	180	180	150	180	180	180	150	180	180
XX(25)	100	100	1000	500	9000	900	1900	600	900	800	2000	50	2200	700	100
XX(26)	100	100	2000	900	1500	2000	3000	1000	800	1000	5000	1500	5000	2000	2000
XX(27)	1	1	1	1	1	1	1	1	1	1	1	1	1	1	1
XX(28)	500000	120000	9000	6000	90000	50000	50000	50000	40000	40000	400000	2000	40000	40000	3000
XX(29)	130	50	60	45	12	45	70	60	60	60	100	180	60	45	160
XX(30)	20	.25	2	3	3	5	5	3	3	5	3	5	2	2	3
XX(31)	5	5	3	4	5	3	5	1	3	4	3	3	1	4	5

Card Group XI

Not needed for this problem.

ANALYSIS RESULTS SUMMARY

The analysis results from solving a range of LCC constraints problems for the test case are summarized in Tables XIII and XIV. The five allocation algorithms and column headings in Tables XIII and XIV are the same as those previously given for the example problem discussed in Section IV. The results for this test case are, in general, analogous to the results for the previous example problem. However, if one examines the $E(\text{NORS})_c$ column in Table XIV, he finds (1) that the values for algorithms 4 and 5 are not monotonically decreasing (at a constraint of \$ 78 M); and (2) at two constraints (\$ 80 M and \$ 89 M), algorithm 3 has a value lower than the values of algorithms 4 and 5. This can be explained by the heuristic nature of the algorithms, and by the fact that allocations are being made from the non-convex regions of the item functions, $\{g_{i,n}\}$. Despite an occasional small reversal, if one applies a little decision theory (either maximin or expected value), he would prefer to use algorithms 4 and 5 instead of algorithms 1, 2, or 3 to estimate the minimum value for $E(\text{NORS})_c$.

SAMPLE OUTPUT DISPLAYS

Tables XV, XVI, and XVII show sample printout displays for the test case. Table XV shows the total system sum of expected backorders and LCC corresponding to the fifteen Lagrange multipliers.

Table XVI is a tabulation of the KJ variable for each item for each of the 15 Lagrange multipliers. The definition of KJ was previously discussed in Supplement A. Table XVII shows the item and depot(s) summary printout for a LCC constraint of \$ 89 M.

TABLE XIII
COMPARISON OF ALLOCATION ALGORITHMS FOR MINIMIZING THE SUM OF
EXPECTED BACKORDERS FOR THE TEST CASE WITH SOME $u_i > 1$

COST CONSTRAINT \$, M	SUM OF EXPECTED BACKORDERS			MAXIMUM PERCENT POSSIBLE REDUCTION FOR SOLUTION			E(NORS) _{nc}		
	1	2	3	1	2	3	1	2	3
70.954	240.9	240.9	240.9	0.0525	0.0525	0.0525	226.5	226.5	226.5
71.	107.3	106.9	106.9	0.4326	0.0667	0.0667	104.2	103.8	103.8
72.	76.8	76.1	76.1	0.9522	0.0367	0.0667	75.2	74.6	74.6
73.	63.6	62.3	62.2	2.3775	0.1813	0.1086	62.5	61.2	61.2
74.	53.2	52.4	52.4	1.8653	0.1555	0.1660	52.4	51.7	51.7
76.	37.6	37.2	37.1	1.0499	0.1597	0.0221	37.2	36.9	36.3
78.	25.6	25.1	25.1	2.1895	0.1623	0.2271	25.4	24.9	24.9
80.	17.1	16.3	16.3	5.3138	0.5541	0.5389	17.0	16.2	16.2
82.	10.2	10.1	10.1	1.2058	0.1705	0.1705	10.2	10.1	10.1
84.	8.60	7.22	6.97	24.5728	4.7079	1.0027	8.58	7.21	6.96
86.	5.07	4.71	4.59	11.1557	3.1542	0.6919	5.06	4.70	4.59
89.	2.17	2.04	2.03	7.7145	1.4632	0.7391	2.17	2.04	2.03

TABLE XIV
COMPARISON OF ALLOCATION ALGORITHMS FOR MINIMIZING THE SUM OF
EXPECTED NORS WHEN CANNIBALIZING FOR THE
TEST CASE WITH SOME $u_i > 1$

COST CONSTRAINT \$, M	E(NORS) _c					TOTAL NUMBER OF UNITS OF STOCK			Δ LCC UNDER CONSTRAINT, \$		
	1	2	3	4	5	1	2	3	1	2	3
70.954	53.9	53.9	53.9	53.9	53.9	15	15	15	380,240	380,240	380,240
71.	14.9	14.8	14.8	10.6	10.6	177	178	178	5,855	855	855
72.	10.5	10.5	10.5	10.1	9.34	281	284	284	44,770	770	770
73.	9.92	9.92	9.92	8.04	8.65	311	319	319	142,415	515	395
74.	9.06	9.06	9.06	7.94	7.10	388	343	344	106,497	1,597	1,573
76.	9.06	9.06	9.06	6.25	5.22	383	391	387	55,485	4,503	1,377
78.	8.04	8.04	8.04	7.16	5.58	457	473	471	122,768	1,375	543
80.	2.40	2.32	2.31	2.61	2.77	489	516	502	208,152	309	1,834
82.	2.07	2.07	2.07	2.05	2.02	575	584	584	69,285	1,385	1,385
84.	2.07	2.07	1.77	1.65	1.34	592	633	614	1,098,855	1,648	1,816
86.	1.63	1.63	1.55	1.13	0.85	646	686	686	525,289	1,589	1,053
89.	0.29	0.29	0.29	0.31	0.33	719	746	725	242,708	909	489

TABLE XV

TOTAL SYSTEM SUM OF EXPECTED BACKORDERS AND LCC FOR THE
TEST CASE WITH SOME $u_i > 1$

K	LA48DA(K)	BT(K)	LCC(K)
1	.9132278E+00	.2409246E+03	.7059376E+08
2	.1935262E-04	.8026935E+02	.7175433E+08
3	.1238925E-04	.6512454E+02	.7272058E+08
4	.1000000E-04	.5581871E+02	.7361050E+08
5	.7943282E-05	.4825514E+02	.7449591E+08
6	.6309573E-05	.3302227E+02	.7657591E+08
7	.5011872E-05	.2684659E+02	.7760575E+08
8	.3991072E-05	.1546232E+02	.8018220E+08
9	.3152278E-05	.1441885E+02	.8046705E+08
10	.2511886E-05	.1063240E+02	.8172781E+08
11	.1935262E-05	.1029115E+02	.8189371E+08
12	.1584893E-05	.8595054E+01	.8290134E+08
13	.1000000E-05	.5549581E+01	.8498272E+08
14	.6309573E-06	.1720900E+01	.8945831E+08
15	.3152278E-06	.1224174E+01	.9066321E+08

TABLE XVI
SAMPLE PRINTOUT OF THE KJ-ARRAY FOR THE TEST CASE
WITH SOME $u_i > 1$

	LAGRANGE MULTIPLIER NUMBER														
	1	2	3	4	5	6	7	8	9	10	11	12	13	14	15
FOR ITEM 1	1	31	32	33	33	34	34	34	47	47	48	48	49	50	51
FOR ITEM 2	1	24	26	25	27	28	28	23	23	42	43	43	44	45	47
FOR ITEM 3	1	1	1	1	2	2	18	13	13	19	19	19	20	35	36
FOR ITEM 4	1	1	1	1	1	17	17	19	19	18	18	18	19	34	35
FOR ITEM 5	1	1	4	13	23	21	21	22	22	37	38	38	39	54	55
FOR ITEM 6	1	1	2	3	3	3	4	13	13	19	20	20	20	21	36
FOR ITEM 7	1	4	5	5	5	21	21	22	22	23	23	24	24	39	40
FOR ITEM 8	1	1	1	1	1	1	2	2	2	3	3	3	18	19	20
FOR ITEM 9	1	1	4	3	3	20	21	22	23	23	24	30	39	40	41
FOR ITEM 10	1	6	22	22	23	24	24	33	33	40	40	41	42	56	58
FOR ITEM 11	1	147	150	151	133	154	155	155	155	167	168	169	172	174	185
FOR ITEM 12	1	26	27	27	28	28	29	42	42	43	43	44	44	45	46
FOR ITEM 13	1	1	2	2	19	18	19	13	13	20	20	20	36	36	37
FOR ITEM 14	1	1	1	1	2	3	3	13	13	20	20	21	21	37	38
FOR ITEM 15	1	28	29	29	33	43	43	44	44	45	45	46	47	48	61

TABLE XVII
ITEM AND DEPOT(S) SUMMARY PRINTOUT DISPLAY FOR THE
TEST CASE WITH SOME $u_j > 1$

(The solution is for a LCC constraint of \$89 M.)

ITEM ID.	STOCK LEVELS		STRATEGY	ITEM AND DEPOT(S) SUMMARY			NO. OF DEPOT AGE	TOTAL LCC(M), \$
	DEPOT	BASES		TOTAL	EXPECTED BACKORDERS	EXPECTED MORS INDEX		
ITEM 1	14	34	MR	.012	.012	.548	1.	2862757.
ITEM 2	10	34	0	.075	.075	.347	1.	3756066.
ITEM 3	8	34	80	.175	.175	.119	1.	6007507.
ITEM 4	1	17	90	.331	.083	5.780	1.	2073807.
ITEM 5	5	44	0	.314	.157	1.073	1.	11710252.
ITEM 6	4	23	30	.165	.165	1.387	1.	4.003000.
ITEM 7	7	25	90	.328	.164	1.387	1.	7992031.
ITEM 8	1	17	80	.215	.215	2.312	1.	5816922.
ITEM 9	5	34	80	.396	.178	1.314	1.	11023142.
ITEM 10	7	46	30	.172	.172		1.	7594655.
ITEM 11	102	68	MR	.024	.012			6390093.
ITEM 12	18	34	8	.025	.025			1733387.
ITEM 13	2	31	80	.316	.158	.462	1.	6983468.
ITEM 14	5	39	80	.162	.162	1.387	1.	8689603.
ITEM 15	13	34	B	.042	.042			2344094.
TOTAL	186	514	708	2.712	.328	15.596	11.	88998633.

SUM OF EXPECTED MORS AT ALL BASES (FOR THE COMPLETE CANNIBALIZATION CASE)