

AD-A035 339

TELEDYNE GEOTECH GARLAND TEX
OPERATION OF THE TONTO FORES SEISMOLOGICAL OBSERVATORY. (U)
AUG 76

F/G 17/10

UNCLASSIFIED

TR-76-7

F08606-74-C-0007

NL

1 of 2

AD
A035339



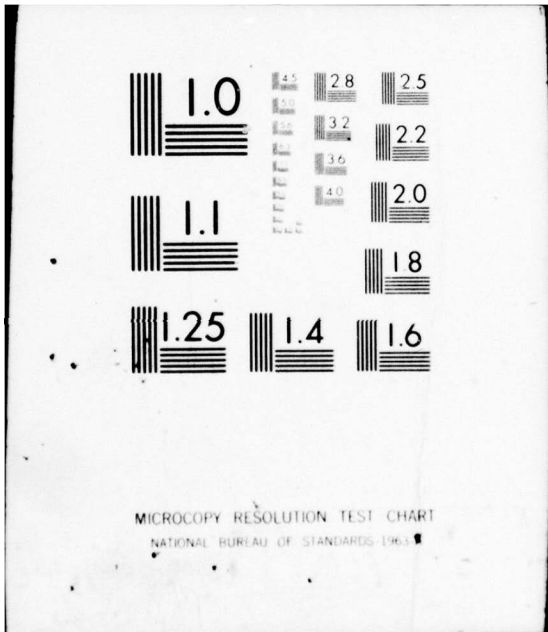

TR 76-7

ADA 035339



TECHNICAL REPORT NO. 76-7

OPERATION OF THE
TONTON FOREST SEISMOLOGICAL OBSERVATORY
FINAL REPORT, PROJECT VT/4704
CONTRACT F0606-74-C-0007
JULY 1959 THROUGH 12 JUNE 1976

DDC
RECEIVED
FEB 6 1977
RESULTS

APPROVED FOR PUBLIC RELEASE
UNCLASSIFIED

Unclassified

SECURITY CLASSIFICATION OF THIS PAGE (When Data Entered)

REPORT DOCUMENTATION PAGE		READ INSTRUCTIONS BEFORE COMPLETING FORM	
1. REPORT NUMBER 6	2. GOVT ACCESSION NO. 9) Final rept. 1 Jul 73-14 Jun 76	3. RECIPIENT'S CATALOG NUMBER 14 Jun 76	
4. TITLE (and Subtitle) Operation of Tonto Forest Seismological Observatory, Final Report, Project VT/4704, 1 July 1973 through 14 June 1976		5. TYPE OF REPORT & PERIOD COVERED Final. 1 July 1973 through 14 June 1976.	
7. AUTHOR(s) Geotech Staff		6. PERFORMING ORG. REPORT NUMBER 14) TR-76-7	
		8. CONTRACT OR GRANT NUMBER(s) 15) F08606-74-C-0007	
9. PERFORMING ORGANIZATION NAME AND ADDRESS Teledyne Geotech 3401 Shiloh Road Garland, Texas 75041		10. PROGRAM ELEMENT, PROJECT, TASK AREA & WORK UNIT NUMBERS VELA T/4704 describes: (4)	
11. CONTROLLING OFFICE NAME AND ADDRESS Advanced Research Projects Agency Nuclear Monitoring Research Office Arlington, VA 22209		12. REPORT DATE 11) 2 Aug 76	
		13. NUMBER OF PAGES 112	
14. MONITORING AGENCY NAME & ADDRESS (if different from Controlling Office) 12) 116p.		15. SECURITY CLASS. (of this report)	
		15a. DECLASSIFICATION/DOWNGRADING SCHEDULE	
16. DISTRIBUTION STATEMENT (of this Report) Approved for Public Release. Distribution Unlimited.			
17. DISTRIBUTION STATEMENT (of the abstract entered in Block 20, if different from Report)			
18. SUPPLEMENTARY NOTES			
19. KEY WORDS (Continue on reverse side if necessary and identify by block number) Long-Period Array Short-Period Array Seismograph Operating Parameters Multichannel Filter			
20. ABSTRACT (Continue on reverse side if necessary and identify by block number) This is a report of the work accomplished on Project VT/4704 from 1 July 1973 through 14 June 1976. It describes the operation, evaluation, and improvement of the Tonto Forest Seismological Observatory (TFSO), located near Payson, Arizona, the research and test functions carried out at the TFSO; and the research tasks performed by the Geotech staff in Garland, Texas, using TFSO data. Actual operation of the Observatory was terminated on 28 February 1975. (cont on p1473B) ←			

DD FORM 1473 EDITION OF 1 NOV 65 IS OBSOLETE

405770

SECURITY CLASSIFICATION OF THIS PAGE (When Data Entered)

Cont HP 1473A)

Unclassified

SECURITY CLASSIFICATION OF THIS PAGE(When Data Entered)

20. Retrieval and disposition of spiral-4 cable and junction boxes from the field and final disposition of government-furnished property were completed by 14 June 1976.

A

1473B

SECURITY CLASSIFICATION OF THIS PAGE(When Data Entered)

White Section	<input checked="" type="checkbox"/>
Buff Section	<input type="checkbox"/>
UNCLASSIFIED	<input type="checkbox"/>
CLASSIFIED	<input type="checkbox"/>
CLASSIFICATION CODES	
CLASSIFICATION SPECIAL	

A

TECHNICAL REPORT NO. 76-7
 OPERATION OF THE
 TONTO FOREST SEISMOLOGICAL OBSERVATORY
 Final Report, Project VT/4704
 Contract F08606-74-C-0007
 1 July 1973 through 14 June 1976

Sponsored by

Advanced Research Projects Agency
 Nuclear Monitoring Research Office
 ARPA Program Code No. 3F10

Neither the Advanced Research Projects Agency nor the Air Force Technical Applications Center will be responsible for information contained herein which has been supplied by other organizations or contractors, and this document is subject to later revisions as may be necessary. The views and conclusions presented are those of the authors and should not be interpreted as necessarily representing the official policies, either expressed or implied, of the Advanced Research Projects Agency, the Air Force Technical Applications Center, or the U. S. Government.

TELEDYNE GEOTECH
 3401 Shiloh Road
 Garland, Texas 75041

DDC
 RECEIVED
 FEB 8 1977
 RECEIVED
 D

2 August 1976

DISTRIBUTION STATEMENT A
 Approved for public release;
 Distribution Unlimited

CONTENTS

	<u>Page</u>
1. INTRODUCTION	1
1.1 Authority	1
1.2 History	1
1.3 Work of Project VT/4704	3
2. SUMMARY	3
3. OPERATION OF THE TONTO FOREST SEISMOLOGICAL OBSERVATORY	4
3.1 General	4
3.2 Seismograph systems operated during Project VT/4704	4
3.2.1 Nineteen-element array	4
3.2.2 Seven-element array of three-component long-period seismographs	4
3.2.3 Broad-band seismograph	6
3.3 Standard seismograph operating parameters	6
3.4 Data channel assignments	6
3.5 Quality control	6
3.5.1 Quality control of 16-millimeter film seismograms	6
3.5.2 Quality control of analog FM magnetic-tape seismograms	12
3.5.3 Quality control of ASDAS magnetic-tape seismograms	12
3.5.4 Quality control of DGRDAS magnetic-tape seismograms	13
3.7 Calibration of test equipment	14
3.8 Emergency power generator	14
3.9 Security inspection	14
3.10 Government property inspection	15
3.11 Facility maintenance	15
3.12 Spiral-4 transmission circuits	16
3.13 Five-element station	16
3.14 Energy conservation	17
4. MAINTENANCE AND MODIFICATION OF TFSO INSTRUMENTATION	18
4.1 Lightning protection	18
4.2 Short-period seismograph array	18
4.2.1 General	18
4.2.2 Lightning protection	21
4.2.3 Close outer ring	21
4.3 Long-period seismograph array	23
4.3.1 General	23
4.3.2 LP2 and LP3 Drainage	24
4.3.3 Tank Vault Tests at LP6	24
4.3.4 LP field equipment retrofit	28
4.3.5 LP radio telemetry systems	28
4.3.5.1 General	28
4.3.5.2 Design	30
4.3.5.3 Description of equipment	30
4.3.5.4 Performance	46
4.4 Broadband seismograph	46

CONTENTS, Continued

	<u>Page</u>
4.5 Astrodata seismic digital acquisition system	48
4.5.1 Recording time schedule	48
4.5.2 Recording format	48
4.5.3 Operation and maintenance	49
4.6 Digital gain-ranging data acquisition system	49
5. INSTRUMENT EVALUATION	50
5.1 Multichannel filter	50
5.2 Hygrometer	50
5.3 Gravity feed chemical supply system	50
5.4 Field instrument power systems	51
5.4.1 General	51
5.4.2 Solar power	51
5.4.2.1 Solar power at LP5 telemetry site	54
5.4.2.2 Solar power at LP5 sensor site	54
5.4.2.3 Solar power at LP7 telemetry site	54
5.4.3 Wind power	59
5.5 Operation of thermoelectric generators on butane-propane mixture	59
6. FACILITIES AND ASSISTANCE PROVIDED TO OTHER GROUPS	62
6.1 Texas Instrument	62
6.2 Sandia Base	63
7. OBSERVATORY CLOSE-OUT	63
7.1 General	63
7.2 Disposition of government-furnished property	64
7.3 Retrieval and disposal of spiral-4 cable and junction boxes	71
7.3.1 General	71
7.3.2 Retrieval of spiral-4 cable	72
7.3.3 Retrieval of junction boxes	72
7.3.4 Disposal of materials	77
7.4 Real property	80
7.4.1 General	80
7.4.2 Spiral-4 cable and other field materials	81
7.4.3 Transfer of LP1 site to the U. S. Forest Service	81
7.4.4 Rehabilitation of cable trails, access roads, and field installations	81
7.4.5 Disposition of buildings, facility equipment, and miscellaneous items	81

APPENDICES

ILLUSTRATIONS

<u>Figure</u>		<u>Page</u>
1	Location of the Tonto Forest Seismological Observatory	2
2	Vault locations in the 19-element short-period array, and the 7-element long-period array at TFSO	5
3	Normalized response characteristics of standard seismographs at TFSO	7
4	Monthly distribution of lightning storms in TFSO area	19/20
5	TFO channel performance (Sheet 1 of 2) TFO channel performance (Sheet 2 of 2)	21/22 23/24
6	Modifications to short-period array data and calibration lightning protection circuits	26
7	Power spectra of long-period horizontal seismograph noise sensed in three different tank vaults at LP6 during a quiet period	30
8	Power spectra of long-period horizontal seismograph noise sensed in three different tank vaults at LP6 during a noisy period	31
9	Coherence between long-period horizontal seismic noises sensed in a 14414 (with bottom) tank vault and those sensed in a bottomless tank vault at LP6 during a quiet period	33
10	Profile chart for path between Chalk Mountain and LP1 (19.5 miles)	35
11	Profile chart for path between LP7 and LP1 (10.0 miles)	36
12	Major terminals of the TFSO LP radio telemetry circuits	37
13	LP telemetry antenna azimuths	38
14	TFSO LP telemetry system	39
15	Power for LP telemetry circuits	40
16	LP1 radio telemetry circuits	41
17	LP5 and LP7 telemetry circuits	42
18	Radio telemetry installation near LP7	44

ILLUSTRATIONS (Continued)

<u>Figure</u>		<u>Page</u>
19	Telemetry equipment box base of antenna tower, propane tanks, and thermoelectric generator at LP7 telemetry site	45
20	LP7 telemetry site equipment box open, showing repeater, duplexer, and lightning protection and control circuits	46
21	Radio telemetry installation at Chalk Mountain, LP5	47
22	Plat of existing installation at LP1 with antenna tower superimposed	48
23	Radio telemetry installation at LP1	49
24	Response of LP7 telemetry system	51
25	Schematic of Chalk Mountain solar power supply	56
26	Chalk Mountain telemetry station with solar power supply	57
27	Solar power system for LP5 sensor circuits	59
28	Structure built at the LP5 sensor site to support and house components of the solar power system	60
29	*Solar power system installed at the LP7 telemetry site	61
30	Interior view of the enclosure built to house and support components of the solar power system	62
31	Vaporizer assembly with cover removed to show interior	64
32	Thermoelectric Generator and Vaporizer Assembly, Model 34505, and butane/propane fuel tanks installed at LP7 site - TFSO	65
33	Dismantled data switching unit and cabling from the subfloor at TFSO	69
34	Dismantled calibration console at TFSO	69
35	The TFSO data patch unit in process of dismantling	70
36	Loading spiral-4 cable on pallet at TFSO for shipment to 1155th	70
37	Spiral-4 cable being loaded into truck with fork lift at TFSO	71

ILLUSTRATIONS (Continued)

<u>Figure</u>		<u>Page</u>
38	Packaged items to be shipped to USGS, Albuquerque, New Mexico	73
39	Packaged items to be shipped to 1155th, McClellan AFB	73
40	Packaged items to be shipped to Project VT/4703, SDCS, Garland, Texas	74
41	A portion of TFSO test equipment and other property after tagging by various agencies	74
42	The LP5 Chalk Mountain Generator Shack being dismantled	75
43	Partial lot of reeled spiral-4 cable retrieved from the TFSO arrays	77
44	Spiral-4 cable attached to truck prior to dragging to cleared area from brush entanglement	77
45	Spiral-4 cable being reeled onto metal spools using a power reeler	78
46	Empty surplus metal spools	78
47	Spiral-4 cable hocks	79
48	Approximately 30 miles of unreeled spiral-4 cable retrieved from within the TFSO arrays	79
49	Approximately 7 miles of multiconductor cable coiled in various lengths	80
50	A typical multiple cable trail junction box installation	80
51	Approximately 600 assorted sizes junction boxes retrieved from within the TFSO arrays	82
52	Wooden materials used in junction box installations along the multiple cable trails	83
53	Ground rods used in junction box installations along the multiple cable trails and fence poles used in the installations along the single cable trails	83

TABLES

<u>Table</u>		<u>Page</u>
1	Operating parameters and tolerances of standard seismographs at TFSO	8
2	Frequency response norms and tolerances for TFSO short-period seismographs	9
3	Frequency response norms and tolerances for TFSO long-period seismographs	9
4	Frequency response norms and tolerances for TFSO broad-band seismographs	9
5	Data channel assignments for TFSO 16-millimeter film seismograms made during Project VT/4704	10
6	Data channel assignment for TFSO FM magnetic tape seismograms made during Project VT/4704	11
7	Key to the designations used in the data channel assignments at TFSO	11
8	Spiral-4 transmission circuit failures	16
9	Solid-state amplifiers damaged by lightning	18
10	Astrodata Seismic Digital Acquisition System recording formats used at the TFSO from 1 July 1973 through 28 February 1975	52
11	Summary of the disposition of retrieved salvageable materials at TFSO	81

OPERATION OF THE
TONGO FOREST SEISMOLOGICAL OBSERVATORY
Final Report, Project VT/4704
Contract F08606-74-C-0007
1 July 1973 through 14 June 1976

1. INTRODUCTION

1.1 AUTHORITY

The research described in this report was supported by the Advanced Research Projects Agency, Nuclear Monitoring Research Office, and was monitored by the Air Force Technical Applications Center (AFTAC) under Contract F08606-74-C-0007, dated 1 July 1973. The Statement of Work for Project VT/4704 is included as Appendix 1 to this report.

1.2 HISTORY

The Tonto Forest Seismological Observatory (TFSO), located near Payson, Arizona, as shown in figure 1, was constructed by the United States Corps of Engineers in 1963. TFSO was designed to record seismic events and to be used as a laboratory for testing, comparing, and evaluating advanced seismograph equipment and recording techniques. The instrumentation was assembled, installed, and operated until 30 April 1965 by United Electrodynamics (UED) - later Earth Sciences, A Teledyne Company - under Contract AF 33(657)-7747. In March 1964, the Long-Range Seismic Measurements (LRSM) Program provided eight mobile seismic recording vans to extend the existing instrument arrays at TFSO. On 1 May 1965, Geotech assumed the responsibility of operating TFSO. The LRSM vans were phased out of the TFSO operation on 3 October 1965. During the 20-month period from 1 May 1965 through 31 December 1966, the operation of TFSO under Project VT/5055 was closely allied with the work performed at the Blue Mountains, Uinta Basin, and Wichita Mountains Seismological Observatories under Projects VT/1124, VT/4054, and VT/5054. When reasonable, operating procedural changes, observatory instrumentation improvements, and special research investigations were accomplished simultaneously at all observatories. In other instances, improvements, modifications, and/or procedures that had been developed and proven at another observatory were incorporated into the TFSO operation. During 1967, under Contract AF 33(657)-67-C-0091, Project VT/7702, a 37-element, short-period array and a 7-element long-period array were designed and installed.

From 1967 until operation of the Observatory was shut down on 28 February 1975, seismic data were recorded routinely from both short-period and long-period arrays under Projects VT/8702, VT/9702, VT/0704, VT/2704, VT/3704, and VT/4704. Facilities were provided for testing and evaluating a variety of new seismic instruments, including the triaxial seismometer and the K-S force-balance seismometer system.

After shutdown, the Observatory's technical equipment and other materials were distributed as directed and retrieval and disposition of spirai-4 cable and

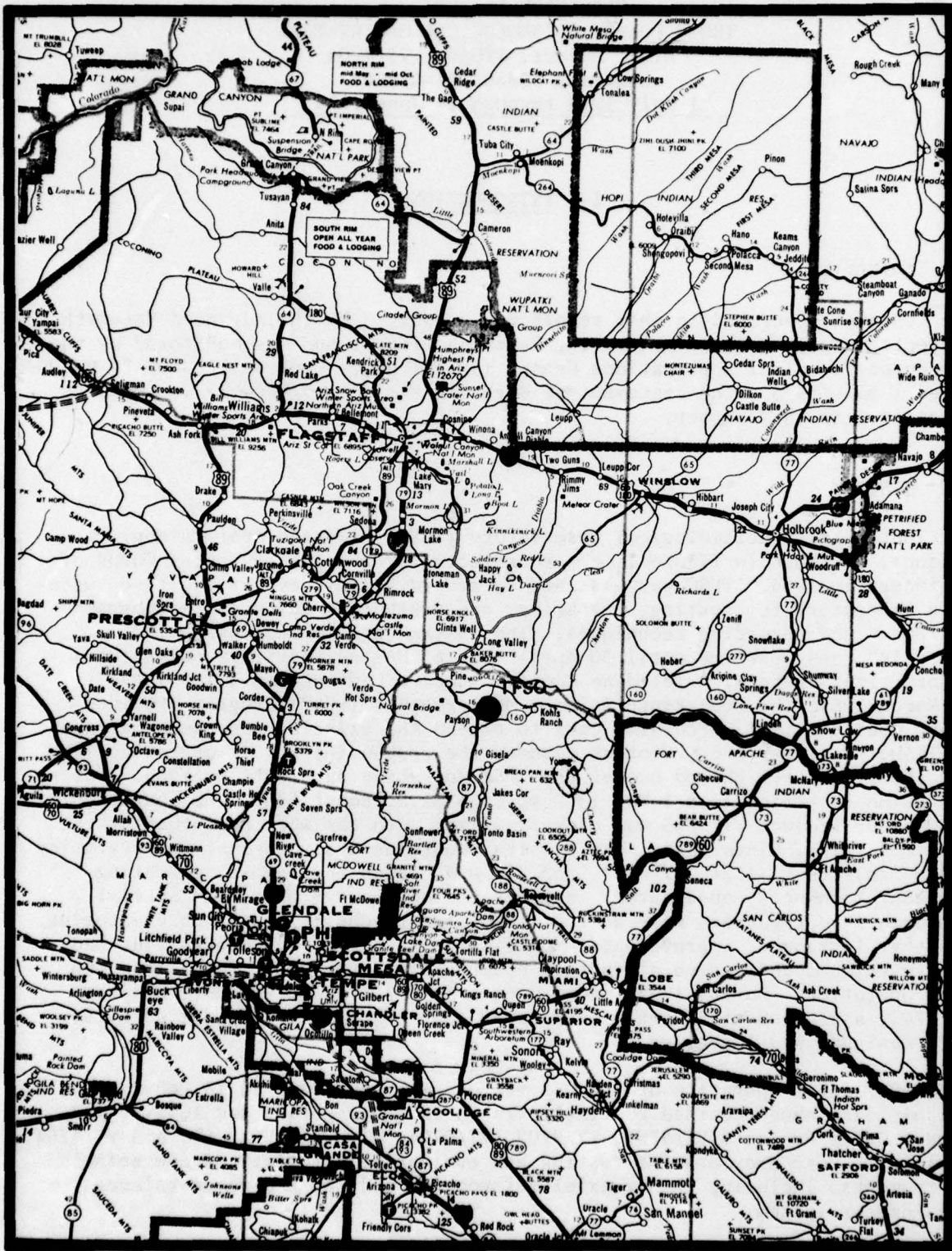

Figure 1. Location of the Tonto Forest Seismological Observatory

G 4970

junction boxes from the field were accomplished. The Corps of Engineers handled disposition of the Real Property, including all buildings.

R. K. Rasmussen was manager of TFSO from May 1965 until his transfer to the Garland office in December 1969. Gayle M. Stanfill then assumed the managerial assignment and continued in this capacity until the Observatory was closed.

B. B. Leichliter was program manager from May 1965 until the Observatory closed, except for the period from February 1974 to May 1975 when M. G. Gudzin was assigned as the program manager.

1.3 WORK OF PROJECT VT/4704

The work of Project VT/4704 was a continuation of the work of earlier TFSO projects. The work of this project can be divided into the following general categories:

- a. Continued operation of TFSO;
- b. Evaluation and improvement of the standard instrumentation to provide a more efficient and effective observatory;
- c. Field testing of newly developed and experimental instrumentation;
- d. Analysis of resulting seismometric data;
- e. Incorporation of new equipment into the systems operating at the TFSO;
- f. Termination of operation and disposal of all instrumentation and materials as directed.

2. SUMMARY

Three seismograph systems were operated continuously at the TFSO from 1 July 1973 through 28 February 1975. The short-period seismograph array system, originally established with 37 elements, was operated as a 19-element array. The 7-element, 3-component long-period array system was operated continuously, except for interruptions required to install radio telemetry links and 3 solar power systems, and to retrofit the remote site instrumentation. The vertical broadband seismograph was operated continuously except for calibration and maintenance.

Equipment was installed and tested to determine the feasibility of fueling a thermoelectric generator with a butane-propane mixture.

The performance of three types of tank vaults was operationally tested at the LP6 site.

Recording of seismic data ended on 28 February 1975, and as directed by the Project Office, all technical equipment was shipped to assignees. Removal and disposition of spiral-4 cable and junction boxes from the field installations completed the close-out task. Real Property was assigned to the Corps of Engineers for disposal.

3. OPERATION OF THE TONTO FOREST SEISMOLOGICAL OBSERVATORY

3.1 GENERAL

Data normally were recorded continuously at the TFSO. Maintenance times, calibration times, and recording film or tape change times were staggered so that data recording was interrupted in only one system at a time.

The Observatory was manned by two personnel shifts, an early one and a late one. From 1 July through 29 October 1973, and from 6 May through 30 September 1974, the early shift hours were from 7:00 a.m. to 4:00 p.m., MST. During the other months of the operational portion of the contract, the early shift hours were from 8:00 a.m. to 5:00 p.m. The late shift hours were always from 9:30 a.m. to 6:00 p.m.

The early shift, worked Mondays through Fridays, except holidays, was the regular work shift for all personnel. The late shift, worked every day, including Saturdays, Sundays, and holidays, was staffed by one man on a rotational basis. The Observatory operated unmanned during the remainder of the time. Technical work was handled by a full-time staff of five people. Secretarial work was handled by one half-time person.

3.2 SEISMOGRAPH SYSTEMS OPERATED DURING PROJECT VT/4704

3.2.1 Nineteen-element Array

A 37-element array of short-period vertical seismographs was installed under Project VT/7702. Under Project VT/8702, this array was evaluated from the standpoint of reliability, beam-steering capability, and detection capability. Operation of this array continued under Projects VT/9702, VT/0704, and VT/2704 until 15 October 1971 when operation of the outer ring of elements was discontinued. The remaining elements were recorded as a 19-element array, figure 2, from 15 October 1971 through February 1974.

When operation of the outer ring of elements was discontinued, the instrumentation was left intact in the event it might be returned to service. During Project VT/4704, it was decided that reuse of the outer ring was not necessary, so the instrumentation was removed and the sites closed.

3.2.2 Seven-Element Array of Three-Component Long-Period Seismographs

A 7-element array of 3-component long-period seismographs was installed during Project VT/7702. Under Project VT/8702, operational difficulties were experienced with seismographs in this array and the major efforts were directed toward

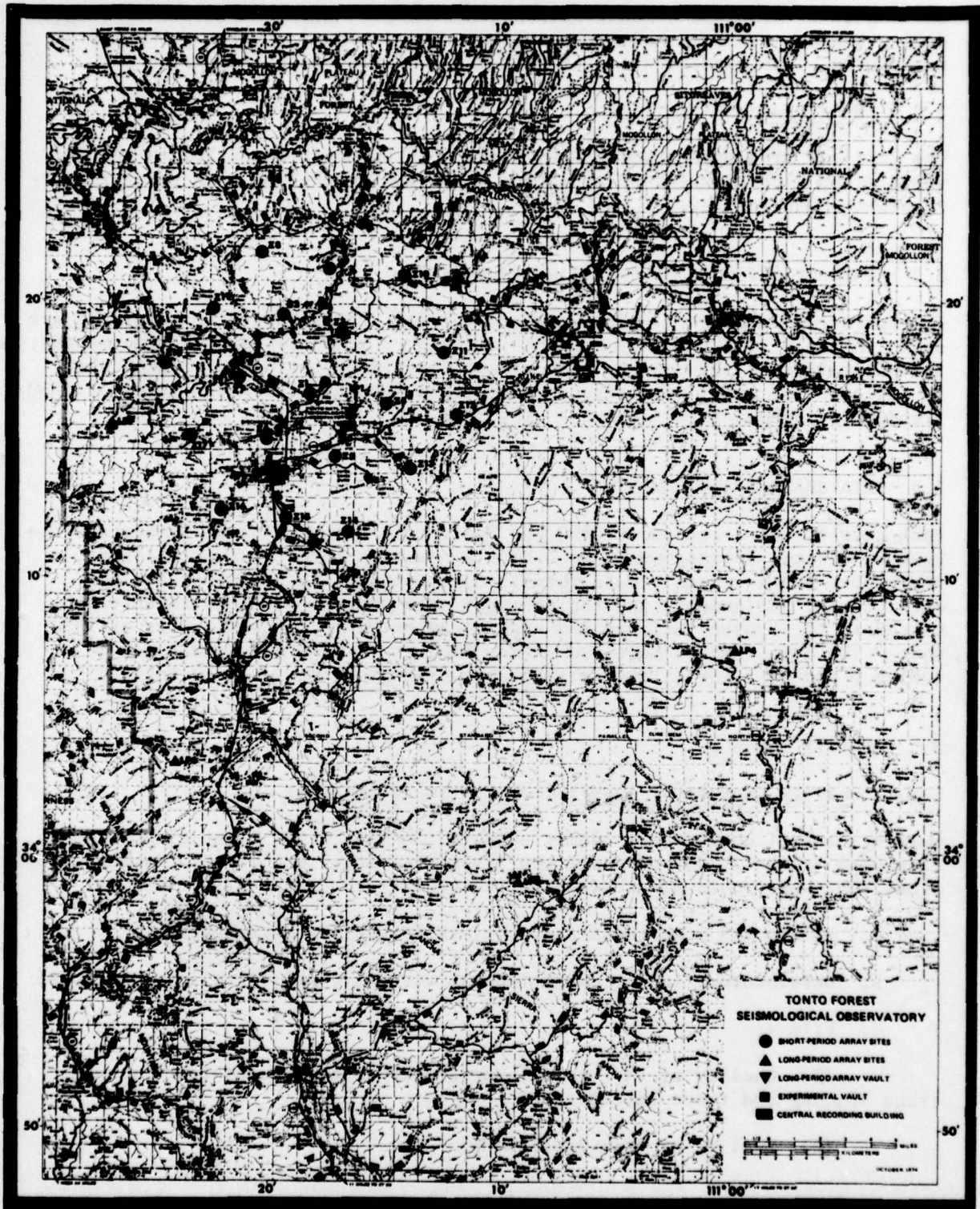

Figure 2. Vault locations in the 19-element short-period array, and the 7-element long-period array at TFSO

solving these problems. Modifications and changes were made to the seismographs during Project VT/9702, and its operation was continued until the Observatory was closed. The configuration of this array is also shown in figure 2.

3.2.3 Broad-Band Seismograph

The vertical broadband seismograph, using a seismometer installed in the LPI vault along with a phototube amplifier installed in the CRB, had the frequency response shown in figure 3.

3.3 STANDARD SEISMOGRAPH OPERATING PARAMETERS

The operating parameters and tolerances for the TFSO standard seismographs are shown in table 1. Frequency response tests were scheduled every three months; the parameters of seismograph systems not conforming to the tolerances shown in tables 2, 3, and 4 were reset. Normalized response characteristics of TFSO standard seismographs are shown in figure 3.

3.4 DATA CHANNEL ASSIGNMENTS

Each data format recorded at TFSO was assigned a number (format number in the case of digital seismograms); each time a new data format was established, a new number was assigned. Data format change notices showing both the new data channel assignments and the previous data channel assignments were submitted to the Project Officer and were distributed to frequent users of TFSO data. The data formats recorded during Project VT/4704 are summarized in tables 5 and 6; a key to the seismograph designators is given in table 7.

3.5 QUALITY CONTROL

3.5.1 Quality Control of 16-Millimeter Film Seismograms

Quality control checks of randomly-selected 16-millimeter film seismograms from Data Trunks 2, 4, and 8 and the associated logs were made in Garland. Items that were routinely checked by the quality control analyst include:

- a. Film boxes - neatness and completeness of box markings;
- b. Develocorder logs - completeness, accuracy, and legibility of logs;
- c. Film -
 - (1) Quality of the overall appearance of the record (for example, trace spacing and trace intensity);
 - (2) Quality of film processing.

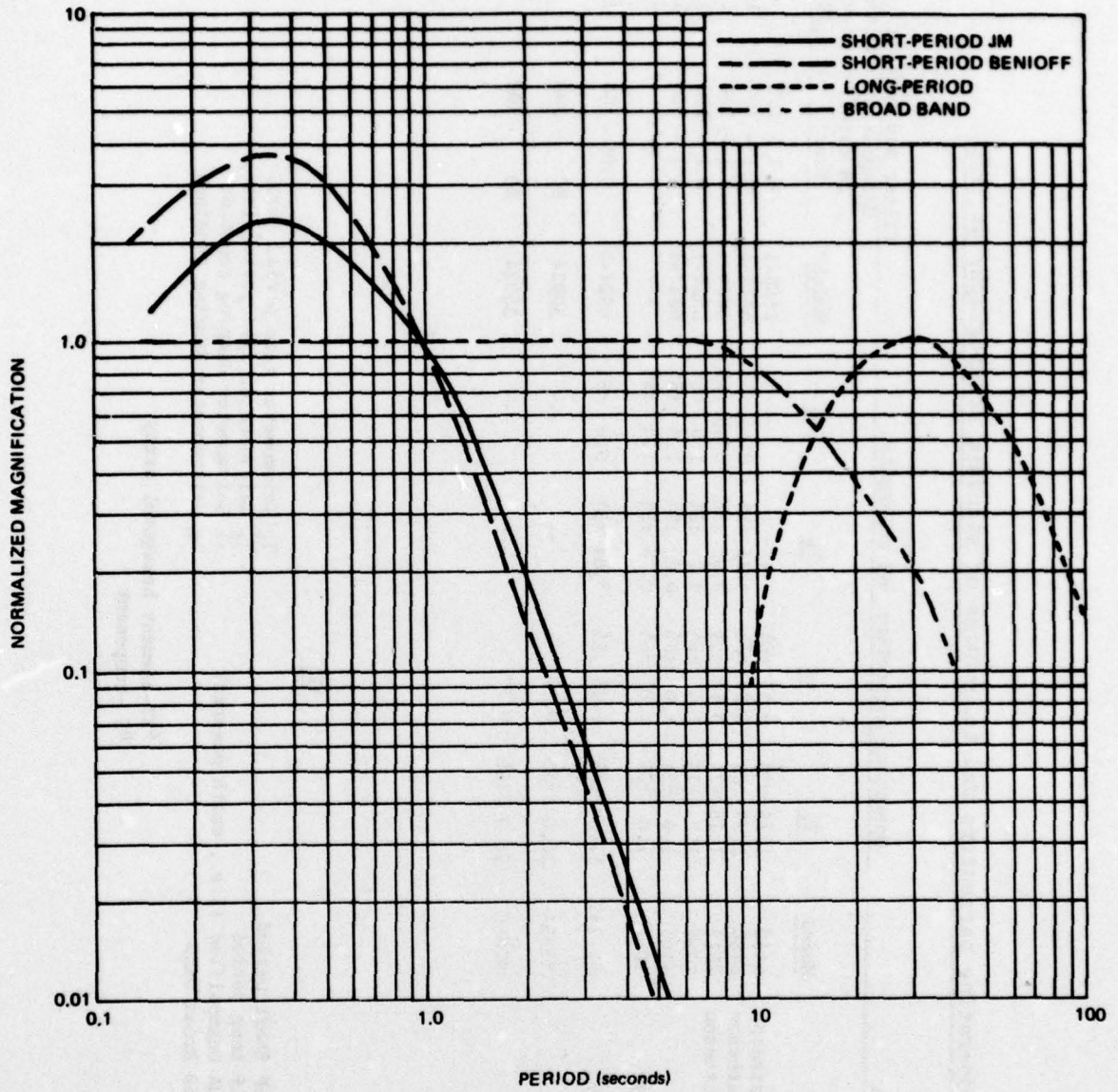

Figure 3. Normalized response characteristics of standard seismographs at TFSO

G 5048

Table 1. Operating parameters and tolerances of standard seismographs at TFSO

Seismograph		Operating parameters and tolerances					Filter and settings		
System	Comp	Type	Model	T _s	λ _s	T _g	λ _g	Bandpass at 3 dB cutoff (sec)	Cutoff rate at SP side (dB/oct)
SP ^a	Z	Johnson-Matheson	6480	1.25 ±2%	0.54 ±5%	---	---	0.2 - 1.0	6
SP ^b	Z	Johnson-Matheson	6480	1.25 ±2%	0.54 ±5%	0.33 ±5%	0.65 ±5%	0.1 - 100	12
SP ^b	H	Johnson-Matheson	7515	1.25 ±2%	0.54 ±5%	0.33 ±5%	0.65 ±5%	0.1 - 100	12
SP	Z	Benioff	1051	1.0 ±2%	1.0 ±5%	0.2 ±5%	1.0 ±5%	0.1 - 100	12
SP	H	Benioff	1101	1.0 ±2%	1.0 ±5%	0.2 ±5%	1.0 ±5%	0.1 - 100	12
SP	Z	UA Benioff	1051	1.0 ±2%	1.0 ±5%	0.75 ±5%	1.0 ±5%	---	---
BB	Z	Press-Ewing	SV-282	12.5 ±5%	0.45 ±5%	0.64 ±5%	9.0 ±5%	0.05 - 100	12
LP	Z	Geotech	7505A	20.0 ±5%	0.77	---	---	80 - 300	6
LP	H	Geotech	8700C	20.0 ±5%	0.77	---	---	80 - 300	6

KEY

SP Short period
 LP Long period
 UA Unamplified (i.e., earth powered)
 BB Broad band

T_s Seismometer free period (sec)
 T_g Galvanometer free period (sec)
 λ_s Seismometer damping constant
 λ_g Galvanometer damping constant

^a37-element hexagonal array
^b3 -component

Table 2. Frequency response norms and tolerances for TFSO
short-period seismographs

T (sec)	f (Hz)	Tolerance (percent)	Relative Amplitude		
			Norm	Max	Min
5.0	0.2	10	0.0118	0.013	0.0106
2.5	0.4	7.8	0.0988	0.106	0.0916
1.25	0.8	5.0	0.68	0.714	0.646
1.00	1.0	0	1.00	1.00	1.00
0.67	1.5	5.2	1.55	1.63	1.47
0.50	2.0	5.1	1.97	2.07	1.87
0.33	3.0	7.3	2.30	2.47	2.13
0.25	4.0	12.2	2.05	2.30	1.80
0.167	6.0	20.3	1.38	1.66	1.10

Table 3. Frequency response norms and tolerances for TFSO
long-period seismographs

T (sec)	f (Hz)	Tolerance (percent)	Relative Amplitude		
			Norm	Max	Min
100	0.01	20	0.135	0.162	0.108
80	0.0125	20	0.278	0.333	0.222
60	0.0167	15	0.485	0.558	0.412
50	0.02	15	0.644	0.741	0.548
40	0.025	10	0.874	0.961	0.787
30	0.033	5	1.03	1.082	0.978
25	0.04	0	1.00	1.00	1.000
20	0.05	5	0.825	0.866	0.784
15	0.0667	10	0.470	0.517	0.423
10	0.1	20	0.110	0.132	0.0879

Table 4. Frequency response norms and tolerances for TFSO
broad-band seismographs

T (sec)	f (Hz)	Tolerance (percent)	Relative Amplitude		
			Norm	Max	Min
25.0	0.04	20	0.104	0.125	0.0832
16.7	0.06	20	0.350	0.420	0.280
12.5	0.08	15	0.775	0.891	0.659
10.0	0.1	10	0.950	1.04	0.855
5.0	0.2	5	1.00	1.05	0.950
2.5	0.4	5	1.00	1.05	0.950
1.25	0.8	0	1.00	1.00	1.00
0.625	1.6	5	1.00	1.05	0.950
0.312	3.2	10	1.00	1.10	0.900
0.156	6.4	15	0.98	1.13	0.833

Table 5. Data channel assignments for TFSO 16-millimeter film seismograms made during Project VT/4704. Dates without asterisks are start dates; dates with asterisks are stop dates.

DEVELOCORDERS

Fast Speed, 30 mm/minute

Channel	Data Group 7299					
	Data Group 7240	21 Oct 70	Data Group 7301	Data Group 7304	Data Group 7309	Data Group 7312
	14 Nov 67 28 Feb 75*	26 Feb 71* 4 Mar 71 9 Aug 73*	30 Mar 71 28 Feb 75*	15 Oct 71 12 Dec 73*	12 Dec 73 7 Feb 74*	7 Feb 74 28 Feb 75*
1	TCDMG	TCDMG	TCDMG	TCDMG	TCDMG	TCDMG
2	Z1	BS 0	MS	Z15	Z15	Z15
3	Z2	BS 1	BFV	Z16	Z16	Z16
4	Z3	BS 2	Z60SP	Z17	Z17	Z17
5	Z4	BS 3	N60SP	Z18	Z18	Z18
6	Z5	BS 4	E60SP	Z19	Z19	Z19
7	Z6	BS 5	Z60LL	Z20	Z20	MS
8	Z7	BS 6	N60LL	ZSH	MS	Wi
9	Z8	BS 7	E60LL	MS	Wi	Z47BF
10	Z9	BS 8	Z60SL	Wi	Z47BF	N47BF
11	Z10	BS 9	N60SL	Z47BF	N47BF	E47BF
12	Z11	FSH	E60SL	N47BF	E47BF	WWV
13	Z12	FTH	Wi	E47BF	WWV	-
14	Z13	WWV	WWV	WWV	-	-
15	Z14	-	-	-	-	-
16	WWV	-	-	-	-	-

Slow-Speed, 3 mm/minute

Channel	Data Group 7276	Data Group 7285	Data Group 7286	Data Group 7303	Data Group 7305	Data Group 7306	Data Group 7307	Data Group 7308
	23 Jan 69 12 Dec 73*	21 May 69 12 Dec 73*	26 Jul 69 12 Dec 73*	19 Aug 71 12 Dec 73*	12 Dec 73 28 Feb 75*	12 Dec 73 28 Feb 75*	12 Dec 73 28 Feb 75*	12 Dec 73 28 Feb 75*
1	Z4LP	Z6LP	Z2LP	TCDMG	TCDMG	Z2LP	Z4LP	Z6LP
2	N4LP	N6LP	N2LP	ML	ML	N2LP	N4LP	N6LP
3	E4LP	E6LP	E2LP	E1LP	Z1LP	E2LP	E4LP	E6LP
4	Z5LP	Z7LP	Z3LP	N1LP	N1LP	Z3LP	Z5LP	Z7LP
5	N5LP	N7LP	N3LP	Z1LP	E1LP	N3LP	N5LP	N7LP
6	E5LP	E7LP	E3LP	ZXLP	MS	E3LP	E5LP	E7LP
7	ML	Z39BB	eZLP	MS	Z1LL	WWV	WWV	Z39BB
8	Wi	ML	ML	ZXLL	N1LL	-	-	WWV
9	WWV	Wi	Wi	Z1LL	E1LL	-	-	-
10	-	WWV	WWV	N1LL	Wi	-	-	-
11	-	-	-	E1LL	WWV	-	-	-
12	-	-	-	WWV	-	-	-	-
13	-	-	-	-	-	-	-	-
14	-	-	-	-	-	-	-	-
15	-	-	-	-	-	-	-	-
16	-	-	-	-	-	-	-	-

Table 6. Data channel assignment for TFSO FM magnetic tape seismograms made during Project VT/4704. Dates without asterisks are start dates; dates with asterisks are stop dates.

FM TAPE RECORDERS						
	Data Group 7239	Data Group 7241	Data Group 7265	Data Group 7302	Data Group 7310	Data Group 7311
	16 Nov 67	15 Nov 67	25 May 68	30 Mar 71	7 Feb 74	7 Feb 74
Channel	28 Feb 75*	7 Feb 74*	28 Feb 75*	7 Feb 74*	28 Feb 75*	28 Feb 75
1	TCDMG	TCDMG	TCDMG	TCDMG	TCDMG	TCDMG
2	Z1	Z13	Z1LP	Z5LP	Z5LP	Z13
3	Z2	Z14	N1LP	N5LP	N5LP	Z14
4	Z3	Z15	E1LP	E5LP	E5LP	Z15
5	Z4	Z16	Z2LP	Z6LP	Z6LP	Z16
6	Z5	Z17	N2LP	N6LP	N6LP	Z17
7	Comp.	Comp.	Comp.	Comp.	Comp.	Comp.
8	Z6	Z18	E2LP	E6LP	E6LP	Z18
9	Z7	Z19	Z3LP	Z7LP	Z7LP	Z19
10	Z8	Z20	N3LP	N7LP	N7LP	-
11	Z9	Z21	E3LP	E7LP	E7LP	-
12	Z10	Z22	Z4LP	εZLP	-	-
13	Z11	Z23	N4LP	-	-	-
14	Z12	Z24	E4LP	Z37	-	-

Table 7. Key to the designations used in the data channel assignments at TFSO

TCDMG	Time Code Data Management Generator
Z	Amplified vertical seismograph from site identified by number
N	North-south horizontal seismograph
E	East-west horizontal seismograph
SP	Short-period seismograph
WWV	Radio time from National Bureau of Standards Radio Station WWV (WWV, STS, and Voice on tape)
BF	Seismograph using Benioff seismometer
LL	Low, low magnification (short-period) or low magnification long-period seismograph
MS	Short-period microbarograph
V	Unamplified (earth-powered) vertical seismograph
SL	Low magnification short-period seismograph
Wi	Wind indicator
LP	Long-period seismograph
BB	Broad-band seismograph
Comp	Tape recorder wow and flutter compensation channel
BS	Beam steer
MCF	Multi-channel filter
FSH	Fisher process

3.5.2 Quality Control of Analog FM Magnetic-Tape Seismograms

Each week, quality control checks of three randomly-selected magnetic tape seismograms were made in Garland and at TFSO to assure the recordings meet specified standards. The following items were checked:

- a. Tape and box labeling;
- b. Accuracy, completeness, and neatness of logs;
- c. Adequate documentation of logs by voice comments on tape where applicable;
- d. Seismograph polarity;
- e. Level of the microseismic background noise;
- f. Level of calibration signals;
- g. Relative phase shift between array seismographs;
- h. Level of system noise;
- i. Oscillator alignment;
- j. Quality of recorded WWV signal where applicable;
- k. Time-pulse carrier;
- l. Binary-coded digital time marks.

3.5.3 Quality Control of ASDAS Magnetic-Tape Seismograms

Quality control checks of ASDAS tapes were made routinely. One tape from each of the two transports was checked weekly for the following items:

- a. Neatness and accuracy of the associated logs;
- b. Polarity errors;
- c. Recording level of each channel;
- d. Fidelity of reproduction;
- e. Presence of header record and correct record length;
- f. Tape parity errors;
- g. Timing information.

3.5.4 Quality Control of DGRDAS Magnetic-Tape Seismograms

Quality control checks of DGRDAS tapes were made routinely. One tape was checked each week for items listed under section 3.5.3 and, in addition, for the following items:

- a. Field transmission parity errors;
- b. Central digital system parity errors;
- c. Gain code errors.

3.6 COMPLETION AND SHIPMENT OF DATA

Two ASDAS digital tapes were shipped each week from TFSO to the Garland laboratory for quality control. All other ASDAS tapes were held at the Observatory for a period of about eight weeks and then recycled if not requested by the SDAC. The following is a list of digital tapes sent to the SDAC.

<u>Run Number</u>	<u>Date</u>	<u>Time</u>	<u>Tape I.D.</u>
73-172	21 June 73	1413:11Z-1625:48Z	14247
73-178	27 June 73	0212:44Z-0425: ~Z	14280
73-179	28 June 73	1850:22Z-2106:14Z	14289
73-191	10 July 73	0000:10Z-0218:44Z	14350
73-197	16 July 73	1639:10Z-1856:08Z	14387
73-204	23 July 73	0000:30Z-0241:05Z	14422
73-209	28 July 73	2053:04Z-2304:43Z	14456
73-227	15 Aug 73	0213:38Z-(unknown due to power failure)	14551
73-230	18 Aug 73	1710:19Z-1924: ~Z	14571
73-230	18 Aug 73	1924: ~Z-2138: ~Z	14572
73-236	24 Aug 73	1630:48Z-1843:46Z	14603
73-236	24 Aug 73	1843:46Z-2057:35Z	14605
73-240	28 Aug 73	0245:06Z-0500: ~Z	14624
73-240	28 Aug 73	1712:30Z-1923:59Z	14626
73-256	13 Sept 73	1415:10Z-1629:24Z	14715
73-262	19 Sept 73	0215:06Z-1430: ~Z	14748
73-285	12 Oct 73	1415:01Z-1625:45Z	14879
73-285	12 Oct 73	1625:45Z-1841:15Z	14880
73-299	26 Oct 73	0242:55Z-0455:00Z	14958
73-332	28 Nov 73	1445:20Z-1701:23Z	15141
73-347	13 Dec 73	1501:10Z-1638:22Z	15219
73-353	19 Dec 73	0215: ~Z-0430: ~Z	15249
73-353	19 Dec 73	1459:30Z-1715:12Z	15250
73-365	31 Dec 73	0230: ~Z-0445: ~Z	15312
74-170	19 June 74	1407:10Z-1622:40Z	16228
74-176	25 June 74	0234:48Z-0500: ~Z	16260
74-188	7 July 74	1635:01Z-1848:16Z	16328
74-188	7 July 74	2106:44Z-2320:54Z	16330
74-191	10 July 74	0212:42Z-0425: ~Z	16344
74-191	10 July 74	1415:01Z-1626:39Z	16345

<u>Run Number</u>	<u>Date</u>	<u>Time</u>	<u>Tape I.D.</u>
74-226	14 Aug 74	1405:01Z-1621:15Z	16540
74-241	29 Aug 74	1403:30Z-1616:06Z	16626
74-242	30 Aug 74	1410:10Z-1626:25Z	16632
74-256	13 Sept 74	0245:08Z-0500:00Z	16709
74-257	14 Sept 74	1845:50Z-2100:58Z	16717
74-268	25 Sept 74	1411:41Z-1625:31Z	16777
74-269	26 Sept 74	1400:10Z-1610:43Z	16783

All Digital Gain Ranging Data Acquisition System (DGRDAS) tapes were sent to the SDAC, except that one per week was sent to Garland for quality control checks.

Four analog FM magnetic-tape units were used to record data for the AFTAC VELA Seismological Center (NYV). FM tapes for six days of each week were sent directly to SDAC. The tapes for the seventh day were sent to our Garland laboratory for quality control inspection, then forwarded to SDAC.

All Develocorder (16-millimeter film) seismograms, except quality control copies, were routinely shipped to SDAC. One seismogram for each Develocorder was sent each week to Garland for quality control, then forwarded to SDAC.

Copies of calibration and operational logs accompanied all data shipments.

3.7 CALIBRATION OF TEST EQUIPMENT

Test instruments were routinely calibrated at TFSO during the contract period and calibration logs were maintained for all such instruments.

The Honeywell Metrology Service of Phoenix, Arizona, was engaged to provide calibrations, repairs, and materials for all test equipment. A calibration recall system and proper labeling of instruments, along with pickup and delivery service, were also provided.

3.8 EMERGENCY POWER GENERATOR

During this report period, the emergency power generator was operated a total of 211.8 hours. It was operated 45.5 hours during loss of commercial power, 15.7 hours during tests under full load, and 150.6 hours to furnish fluctuation-free power during operational test of the Texas Instruments Station Processor.

3.9 SECURITY INSPECTION

Mr. Kenneth G. Ozbolt, Chief, Industrial Security, Phoenix, Arizona, conducted security inspections at the TFSO on 9 October 1973, 24 June 1974, and 17 March 1975.

During his last visit, Mr. Ozbolt explained the procedures we should follow for administrative termination of our facility security clearance. In Appendix 2 are the following:

a. Copy of Geotech's Security Officer's request for administrative termination dated 25 March 1975;

b. Copy of letter from Ken Ozbolt, Industrial Security Officer, to Gayle Stanfill, dated 9 April 1975, reporting that during the 17 March inspection all security requirements were met, and acknowledging receipt of termination request;

c. Copy of letter from B. W. Tanner, Regional Security Officer, to TFSO, dated 24 April 1975, advising that facility clearance had been administratively terminated.

3.10 GOVERNMENT PROPERTY INSPECTION

Government property inspections were conducted on 24 August 1973 by Mr. Lewis R. Madden, DCASD, Phoenix, Arizona, and on 6 June 1974 and 17 March 1975 by Messrs. B. R. Lucart and R. K. Greiner, both from DCASD, Phoenix, Arizona. All items inspected were found to be in order during each visit. During the 17 March visit, groundwork for transferring property was discussed; however, at that time no decisions were reached on disposition of Government Furnished Property or Real Property.

3.11 FACILITY MAINTENANCE

The TFSO facilities were maintained in accordance with sound industrial practices throughout the report period. This work included pest extermination, work area cleaning, and lubrication and cleaning of heating and air conditioning equipment.

The Arizona State Department of Health inspected the Observatory water and sewage systems late in June 1973 and submitted a letter report on their findings in July. These findings, together with system changes they recommended, were discussed with Mr. R. C. Hofferth of the Arizona State Department of Health by the Project Officer, the TFSO Station Manager, and the Program Manager. It was agreed that operation of the TFSO water and sewage systems could remain unchanged, except that the aeration unit should be bypassed and water samples should be submitted twice a month to the State Health Department for analysis. A program of sample submission was begun in August 1973. All checks indicated that the water quality was satisfactory.

In compliance with State regulations, an employee was certified as the chief operator of the TFSO water system.

Mr. R. L. Frey, of the Arizona State Department of Health, inspected the Observatory sewage system on 17 April 1974. His inspection report recommended that the treatment plant area be posted, the treatment plant be bypassed, and the lagoon be kept weed-free. The evaporation lagoon was cleaned and graded and waterproofed with 20 tons of Bentonite to stop water seepage.

State legislation was passed that required operators of waste water systems to be licensed by 1975. Our operator obtained the required license after successfully completing a course in "Domestic and waste water system operation" at the Eastern Arizona College in Payson.

The following other work was performed during the report period to maintain the Observatory facilities. The roads and the parking lots in the vicinity of the Central Recording Building (CRB) and the roads to the walk-in vaults were repaired. Drain tile was installed and covered with sand at two places in the main access road between the State highway and the CRB. Twenty-five miles of cable trails were graded to improve their accessibility. The warehouse and shop building roofs were repaired by coating them with 1-inch thick urethane foam and covering this with a white vinyl sheet. This has not only stopped leaks in the roof, but has also significantly reduced daytime temperatures in the warehouse. The air-handling-unit cooling coil was repaired, and the emergency power generator batteries were replaced.

3.12 SPIRAL-4 TRANSMISSION CIRCUITS

Two hundred nine spiral-4 cable failures were detected and repaired during the report period. The cables were accidentally cut by road repair machinery, deteriorated by exposure to the elements, shot or chopped by vandals and destroyed by lightning. One cable hock failed when its contacts became corroded. Repairs were accomplished by replacing quarter-mile sections of cable, cutting out short damaged sections and splicing together the good sections, and by cleaning one cable hock. Table 8 shows a breakdown of cable failures and repairs during each quarter of the report period.

Table 8. Spiral-4 transmission circuit failures

Cause of failure	Number of failures in each quarter							Totals
	Jul- Sep 73	Oct- Dec 73	Jan- Mar 74	Apr- Jun 74	Jul- Sep 74	Oct- Dec 74	Jan- Feb 75	
Accidental cuts	5	1	4	5	5	1	1	22
Deterioration	17	6	29	12	28	59	8	159
Vandalism	6	2	1	4	2	1	1	17
Lightning	6	0	1	0	0	0	0	7
Corroded hock	0	1	0	0	0	0	0	1
Accidental burn	0	0	0	0	0	3	0	3
Totals	34	10	35	21	35	64	10	209

Repair technique	Number of repairs in each quarter							Totals
	Jul- Sep 73	Oct- Dec 73	Jan- Mar 74	Apr- Jun 74	Jul- Sep 74	Oct- Dec 74	Jan- Feb 75	
Replace cable section	26	5	32	16	28	60	8	174
Splice cable	8	4	3	5	7	4	2	33
Clean hock	0	1	0	0	0	0	0	1
Totals	34	10	35	21	35	64	10	209

3.13 FIVE-ELEMENT STATION

The short-period, five-element station, installed and tested during FY71, was left intact when testing was completed. All materials from the five-element station sites were retrieved during April, 1974. The casings were

cut off at ground level, plugged, and covered with rock. In addition, the three sites that previously were linear array sites were graded to restore original land contours.

3.14 ENERGY CONSERVATION

In response to the energy problems that were faced by the nation, Teledyne Geotech initiated measures directed toward the conservation of energy. These measures included, but were not limited to the following:

- a. Hallway lighting within all facilities were reduced by 50%.
- b. Heating thermostats were inspected, calibrated and set at 68°F.
- c. Cooling thermostats were inspected, calibrated and set at 78°F.
- d. All boilers and air-conditioning units were inspected, cleaned and adjusted to operate at maximum efficiency.
- e. Supervisory personnel were directed to eliminate any unnecessary use of electrical energy in office and laboratory areas.
- f. Custodial personnel routinely monitored working areas to shut off all unnecessary lighting at the close of the workday.
- g. Beginning March 4, 1974, the Garland facility operated on one shift rather than two staggered shifts. This consolidation of the workday resulted in maximum utilization of facilities over a shorter period of time, thus reducing the consumption of energy.
- h. Lunch periods at the Garland facility were reduced to 30 minutes. This was in keeping with the consolidated workday. An indirect savings in gasoline was achieved since most employees are eating lunch at the facility rather than driving to an outside food service.
- i. Car-pooling was encouraged among all employees.
- j. Travel by employees was restricted to only the most essential trips by a minimum number of people.

The foregoing measures were undertaken at all Teledyne Geotech facilities. In addition, the following specific measures were undertaken at the TFSO:

- a. The CRB air conditioning system was modified to reduce electrical power consumption during the colder months and fuel oil consumption during the warmer months.
- b. Lighting in the CRB was reduced by more than 50%.

After these conservation measures were instituted, the monthly electrical power consumption dropped by more than 30%.

4. MAINTENANCE AND MODIFICATION OF TFSO INSTRUMENTATION

4.1 LIGHTNING PROTECTION

The lightning activity in the array area during FY 1974 and FY 1975 was much less than during the previous four years, but the distribution remained very nearly the same. Activity was the greatest during mid-summer and the least during mid-winter. Data for fiscal years 1969 through February 1975 are presented in figure 4.

Table 9 presents historical information about short-period and long-period seismograph array amplifier failures. All amplifiers listed are believed to have been damaged by lightning-induced voltage surges. Amplifiers known to have failed for other reasons are not included. The reason for the small incidence in long-period amplifier failures during FY 1973 cannot be explained.

Table 9. Solid-state amplifiers damaged by lightning

FY Year	Lightning days	Number of Failures		Failures per lightning day	
		SP	LP	SP	LP
1969	32	37	37	1.16	1.16
1970	63	33	17	0.52	0.27
1971	63	25	10	0.40	0.16
1972	90	18*	10	0.20	0.11
1973	81	14	1	0.17	0.012
1974	44	7	5	0.16	0.11
1975	47	8	2	0.17	0.043

*Maintenance in the short-period array was performed on 37 channels during FY1969, 1970, and 1971, and on 19 channels during FY1972, 1973, and 1974.

4.2 SHORT-PERIOD SEISMOGRAPH ARRAY

4.2.1 General

Data from the short-period seismograph array channels Z1 through Z19 were recorded throughout the report period, and data from Z20 was recorded from 1 July 1973 until 7 February 1974. Performance of these channels is shown in figure 5. The following is a list of major component failures that interrupted array channel operation.

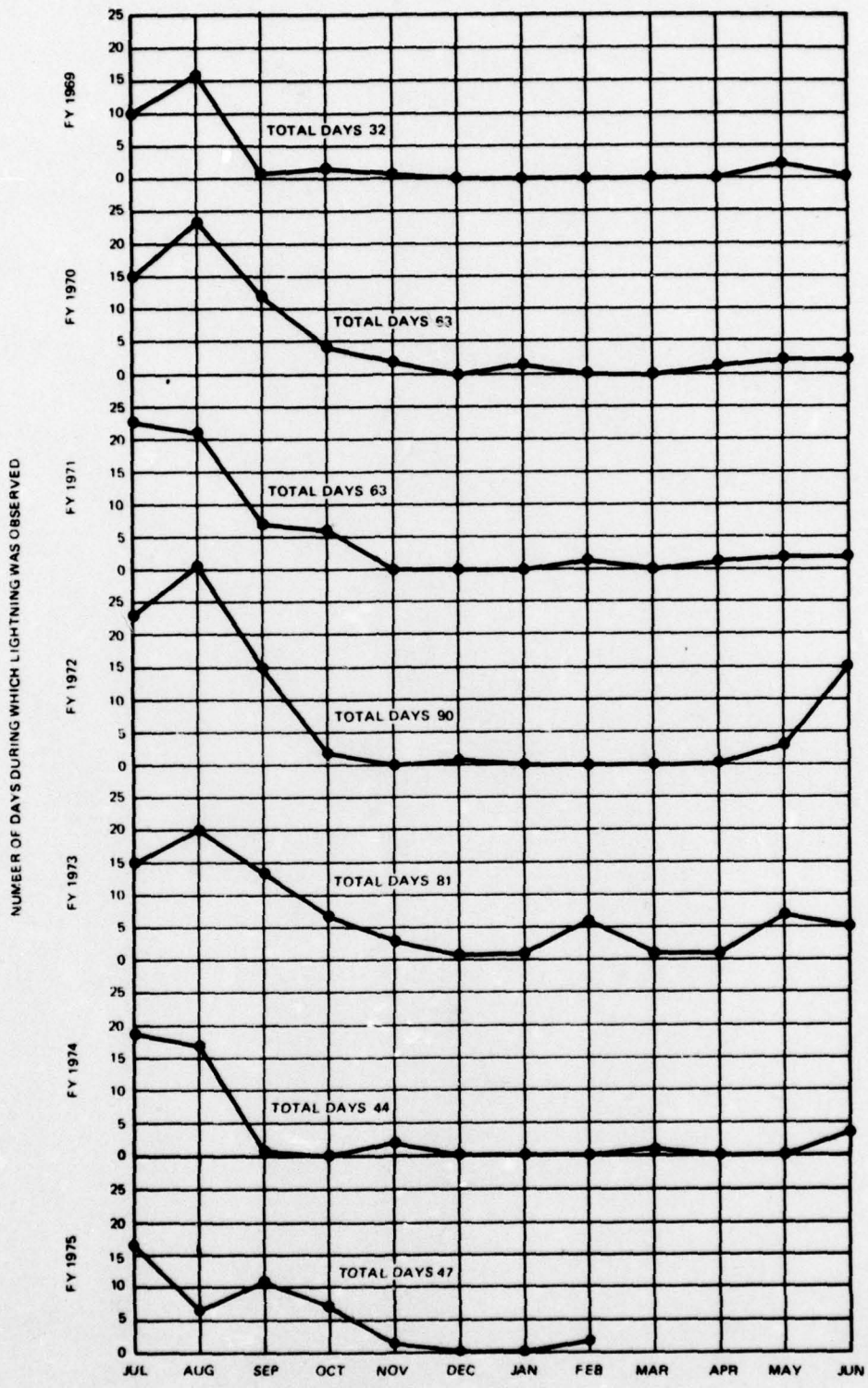

Figure 4. Monthly distribution of lightning storms in TFSO area

L OUTAGE
CHANNEL

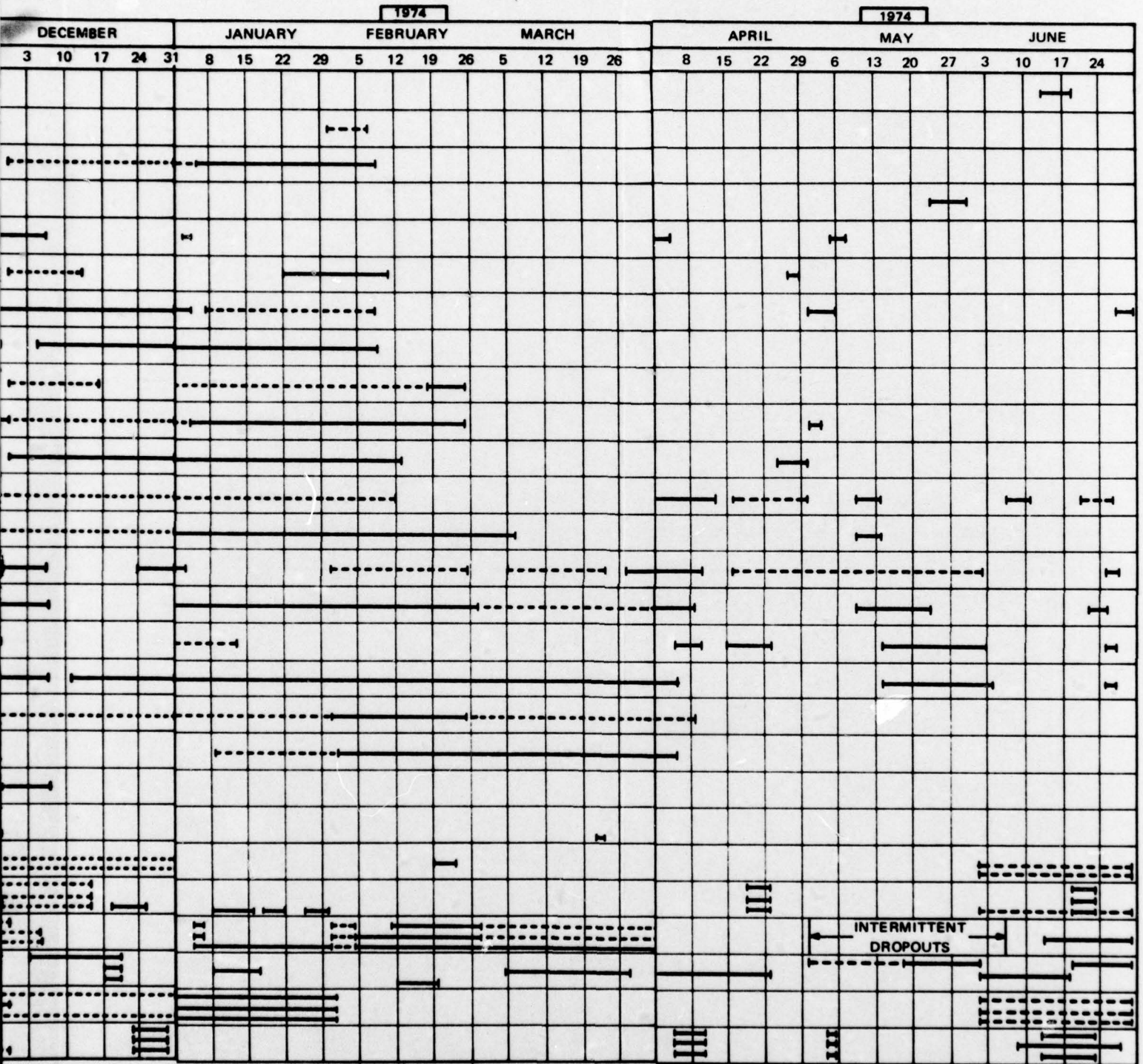
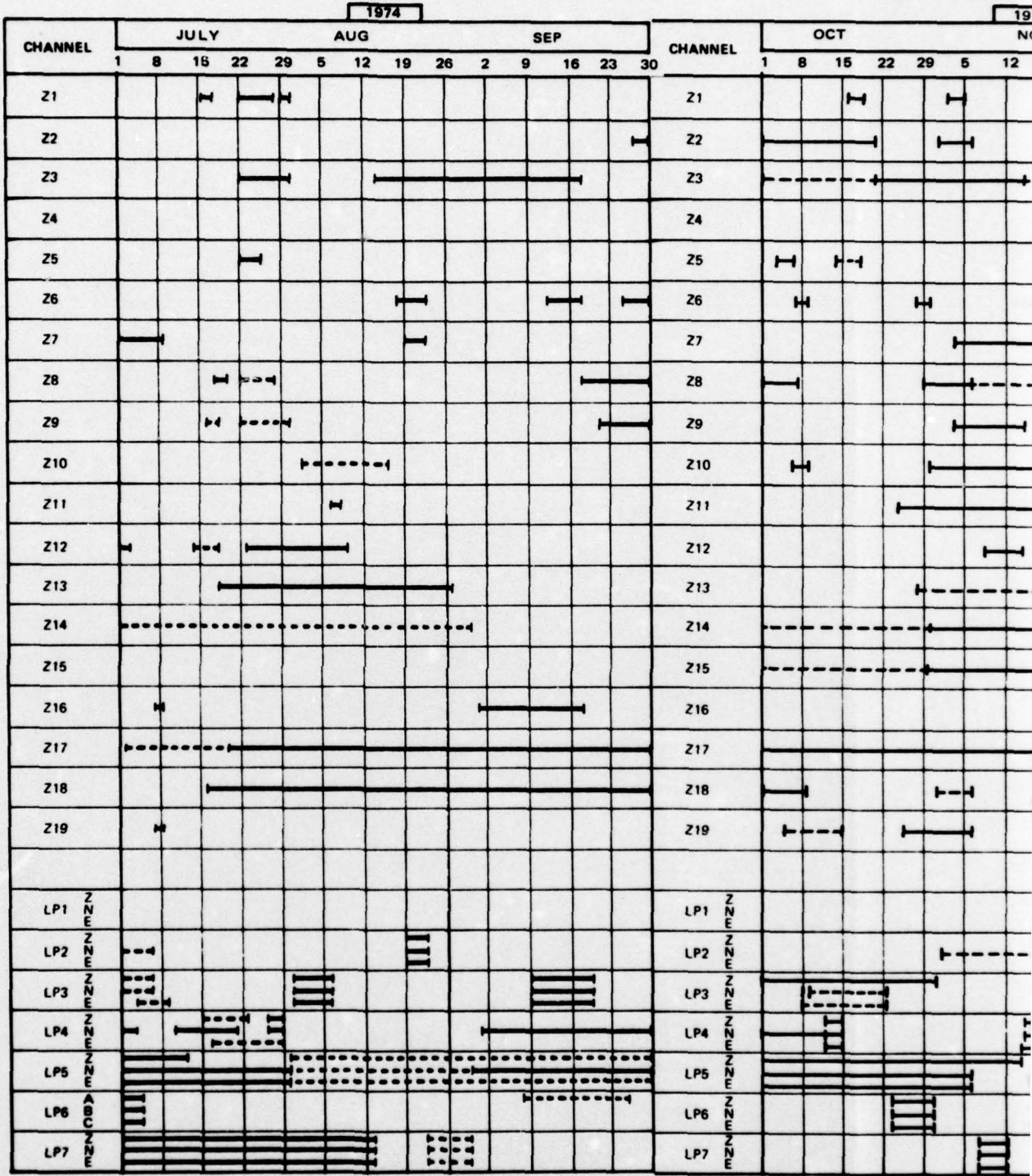
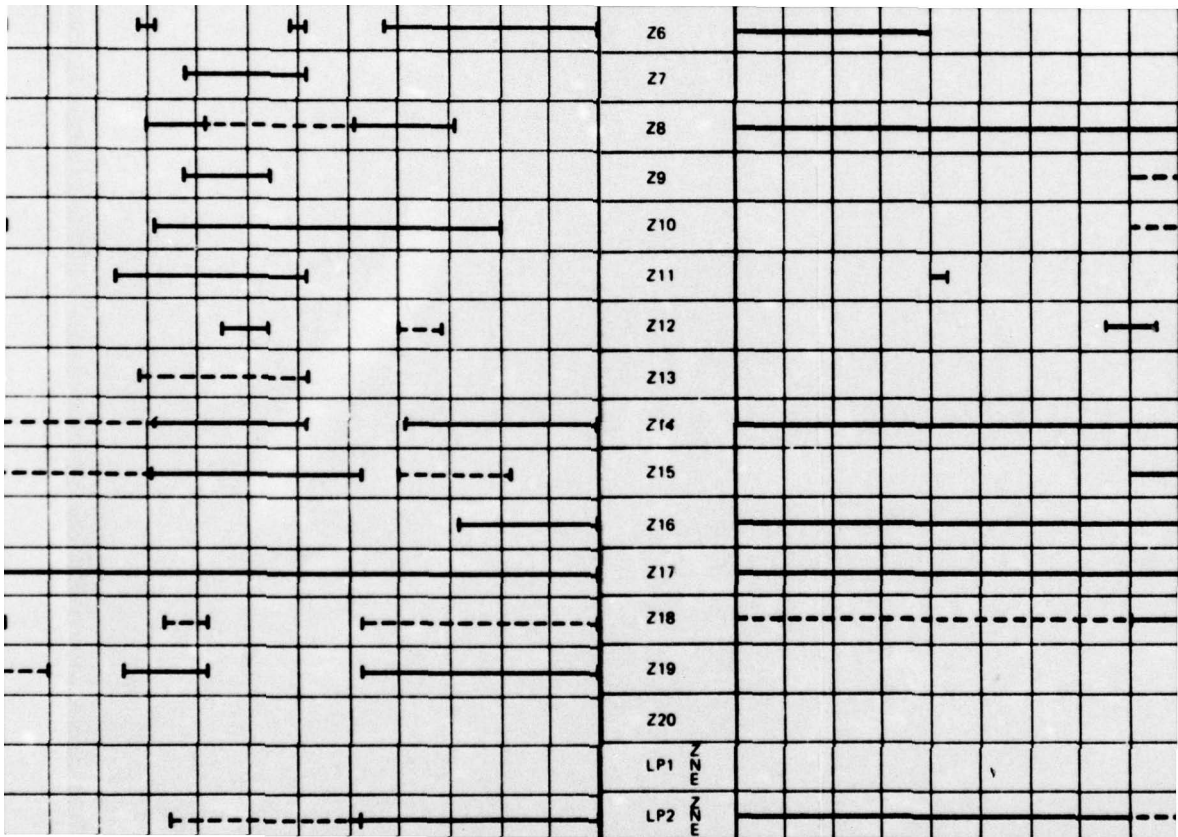

Figure 5. TFO channel performance
(Sheet 1 of 2)

2

SOLID LINE INDICATE
DASH LINE INDICATE





<u>Component</u>	<u>Number of Outages</u>
Spiral-4 cable	95
Amplifier (remote)	21
Isolation filter	11
Wet vault	4
Junction box	1
Calibration circuit	1
Unknown	17

All of the amplifier failures are believed to have been caused by lightning-induced voltage surges. One amplifier failed while its lightning protection circuit was inoperative.

Most outages attributed to cable failures were caused by the failure of several sections of cable. That is, it was necessary to replace 175 sections of cable, perform 33 splices, and clean one hock to restore 95 outages.

4.2.2 Lightning Protection

Modifications to the short-period seismograph array lightning protection circuits, started during FY 73, were completed during July 1974. Figure 6 shows the circuit before and after modification.

4.2.3 Close Outer Ring

The recording of channels Z21 through Z37 was discontinued on 15 October 1971, when only one of these channels was still operational. Maintenance of these channels was discontinued in July 1971 to permit the reduced Observatory work-force to keep the short-period array inner rings and the long-period array operational.

On 19 September 1973, information was assembled and sent to the Project Officer to inform him about the effort that would be required to completely deactivate the outer ring of instruments in the short-period array. This information considered the work that would be required to remove the remote site instrumentation, pick up the spiral-4 cable to these sites, and restore the remote sites and their access roads.

Task Change Proposal No. P1-2244 was submitted on 15 November 1973. It recommended that the work required under Task 4.1 of this contract be increased to include the closure of the outer ring of short-period seismometers and the removal of the cables which linked LP6 and LP7 to the CRB.

Contract Modification No. 3, received on 8 January 1974 authorized accomplishment of this work in four tasks:

Task 1 - Retrieval of Instrumentation and Material from Short-Period Array Sites.

Task 2 - Retrieval of Cable for Short-Period Array Sites in Outer Ring.

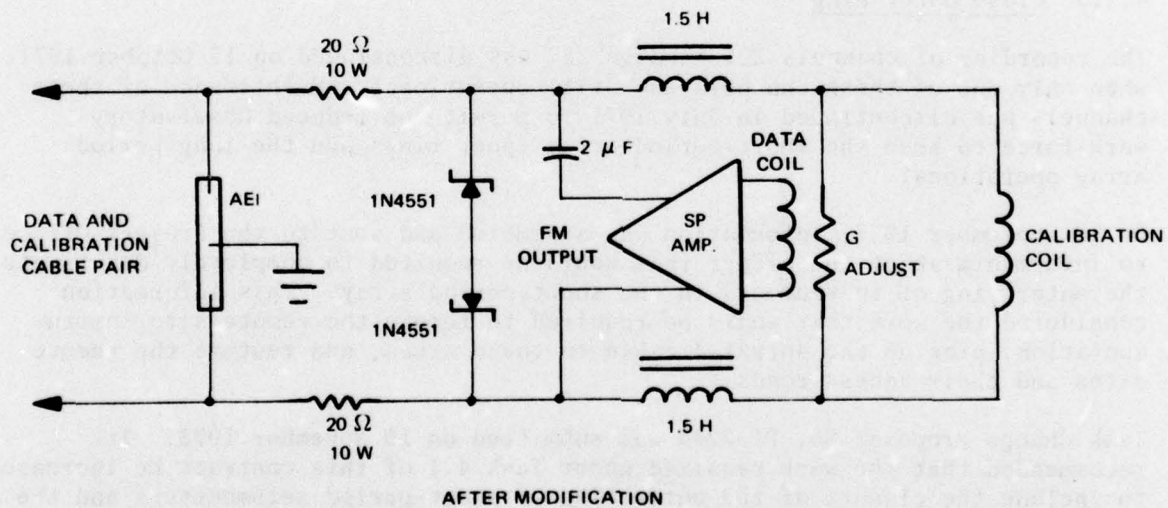
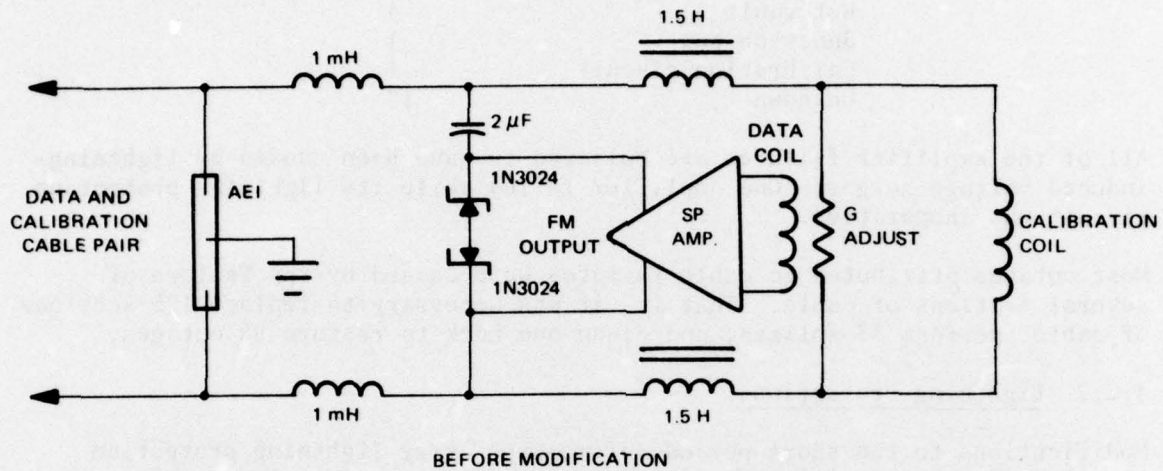

Figure 6. Modifications to short-period array data and calibration lightning protection circuits

G 7206A

Task 3 - Rehabilitation of Short-Period Array Sites in Outer Ring.

Task 4 - Retrieval of Cable to LP6 and LP7.

All tasks were completed by June 1974, and a total of 554 sections of defective spiral-4 cable were picked up and stored in the CRB compound. The instrumentation and material from short-period array sites Z20 through Z37 were retrieved, and the land used for cable trails, access roads, and the sites was rehabilitated.

The cable, plus hocks, empty spools, and fencing materials and miscellaneous salvage materials that had accumulated at TFSO, were transferred to the Navajo County Highway Department as directed by the Plant Clearance Office, DCASD.

4.3 LONG-PERIOD SEISMOGRAPH ARRAY

4.3.1 General

Data from the long-period seismograph array were recorded throughout the report period. The operational status of each channel is shown chronologically in figure 5. The following list shows the major components that failed and interrupted channel operation.

<u>Component or Cause</u>	<u>Number of Failures</u>
Seismometer mass against stop	31
Mass position motor	2
Spiral-4 cable	10
Thermoelectric generator	7
Witte generator	1
Blown fuse	11
Telephone circuit	15
Amplifier	8
Power regulator	2
Vault retrofit	1
Loss of propane fuel	4
Junction box relay failure	3
Radio telemetry transmitter failure	3
Vandalism	2
Free period relay	2
Seismometer	5
Commercial power	5
Wet vault	1
Discriminator	2
Calibration control	2

During this contract, the leading cause of operational interruptions was horizontal seismometer mass drift, the same as it was in previous contracts. Changing ground water levels continued to tilt instrument vaults and cause seismometer masses to move against their stops, disabling the instruments until the masses were recentered.

An oversensitive crowbar circuit in the new radio telemetry power supply at LP1 was responsible for the large number of blown fuses. No fuses blew after that circuit was modified.

4.3.2 LP2 and LP3 Drainage

Trenches were dug at LP2 and LP3 from each tank vault to a lower elevation, drain pipes were installed on gravel poured in the trenches, and the trenches were covered with earth to restore the original land contour.

The work, completed in June 1974, provided a drainage system which prevented tank vaults at these sites from flooding and which improved horizontal instrument mass position stability.

4.3.3 Tank Vault Tests at LP6

During FY 73, under the authorization of Amendments 7 and 8 to Contract F33657-72-C-0800, the location of long-period array site LP6 was changed to improve its operational performance. The old site was noisy and unstable, causing horizontal seismometer masses to drift against their stops frequently. The new site provided a better bedrock foundation for the vaults and exhibited lower noise and greater stability.

During the relocation of LP6, a tank vault experiment was initiated to compare the performances of identical long-period seismograph systems using three different types of tank vaults to house the system sensors. This was facilitated by the installation of the three different types of tank vaults in a common excavation on separate but identical concrete piers. A Lamont-Dougherty tank vault was installed on one pier, a 29060 tank (bottomless) on another, and a 14414 tank (with a meter bottom) on the third. A common wooden structure was installed over all three. One long-period horizontal seismometer was installed with an east-west orientation in each tank. The bottom of each seismometer was approximately eight feet below the earth's surface.

During August and September 1973, insulation of the vault and the individual tanks was completed, the tank seals were tested and found acceptable, and three instruments were put into routine operation. Data were collected during the remainder of FY74.

The performance of the three different tank vaults was evaluated by studying the power density spectra of data from seismographs whose sensors were located in the three different tank vaults.

The method used to compute power density spectra was the very efficient one suggested by Welco (1967)¹. The data were divided into M segments, and each segment was identified by a subscript from 1 to M. Each segment of K data points was transformed into the frequency domain by the use of the Fast Fourier transform.

¹Welch, P.D., 1967, The use of Fast Fourier transform for the estimation of power spectra: Trans. IEEE, AU-15, 70-73.

$$S_m (f) = \sum_{k=0}^{K-1} t_m(k) \exp \left[\frac{-2\pi i k f}{K} \right]$$

The spectral estimates were then obtained by averaging over a number of

$$P_{mn} (f) = \frac{1}{M} \sum_{j=1}^M S_{mJ} (f) \cdot S_{nj}^* (f)$$

segments where the asterisk denotes a complex conjugate, the P_{nn} are spectra of the multiple time series, and the P_{mn} are cross spectra. The number of segments used determines the reliability of the results. For example, using 10 segments is equivalent to taking 10 percent lags using the autocorrelation method. In this study, 18 segments were used.

The coherence was defined as

$$K_{mn} (f) = \frac{|C_{mn} (f) + iQ_{mn} (f)|^2}{P_{mn} (f) \cdot P_{nn} (f)}$$

where C_{mn} and Q_{mn} denoted the real and imaginary parts of the cross-power spectra.

In this study, it was recognized that most of the noise recorded by low-noise, long-period seismographs at periods greater than 20 seconds consists of earth motion caused by atmospheric pressure variations¹ providing that the seismograph system noise is sufficiently low, and that the seismometer mass is well isolated from atmospheric pressure changes. Both these conditions appear to be fulfilled by the instruments used in this study.

Power spectra of the background noise were computed for several samples of both windless (quiet) and windy (noisy) data from all three seismographs. Because the anemometer was located several miles from LP6, accurate data for site wind velocities were not available.

Figure 7 shows the noise spectra on a quiet day. The spectra for periods between 10 and 30 seconds were the same within statistical confidence limits. On either side of this range, the differences in noise level were small and could be attributed to small differences in system responses.

Figure 8 shows the spectra under noisier and presumably quite windy conditions. Note that the noise increased to the point where neither the 8 nor 16 sec

²Sorrells, G. G., McDonald, J. A. Der, Z., and Herrin, E., 1971. Earth motion caused by local pressure changes: Geoph. Jour. 26, 83-98.

18432 SAMPLES, 1024 BLOCK SIZE, 2 SPS
CHANNEL 5 MODEL 14414 (WITH BOTTOM)
CHANNEL 6 BOTTOMLESS
CHANNEL 8 LAMONT DOUGHERTY

9 APRIL 1974
0320/0554

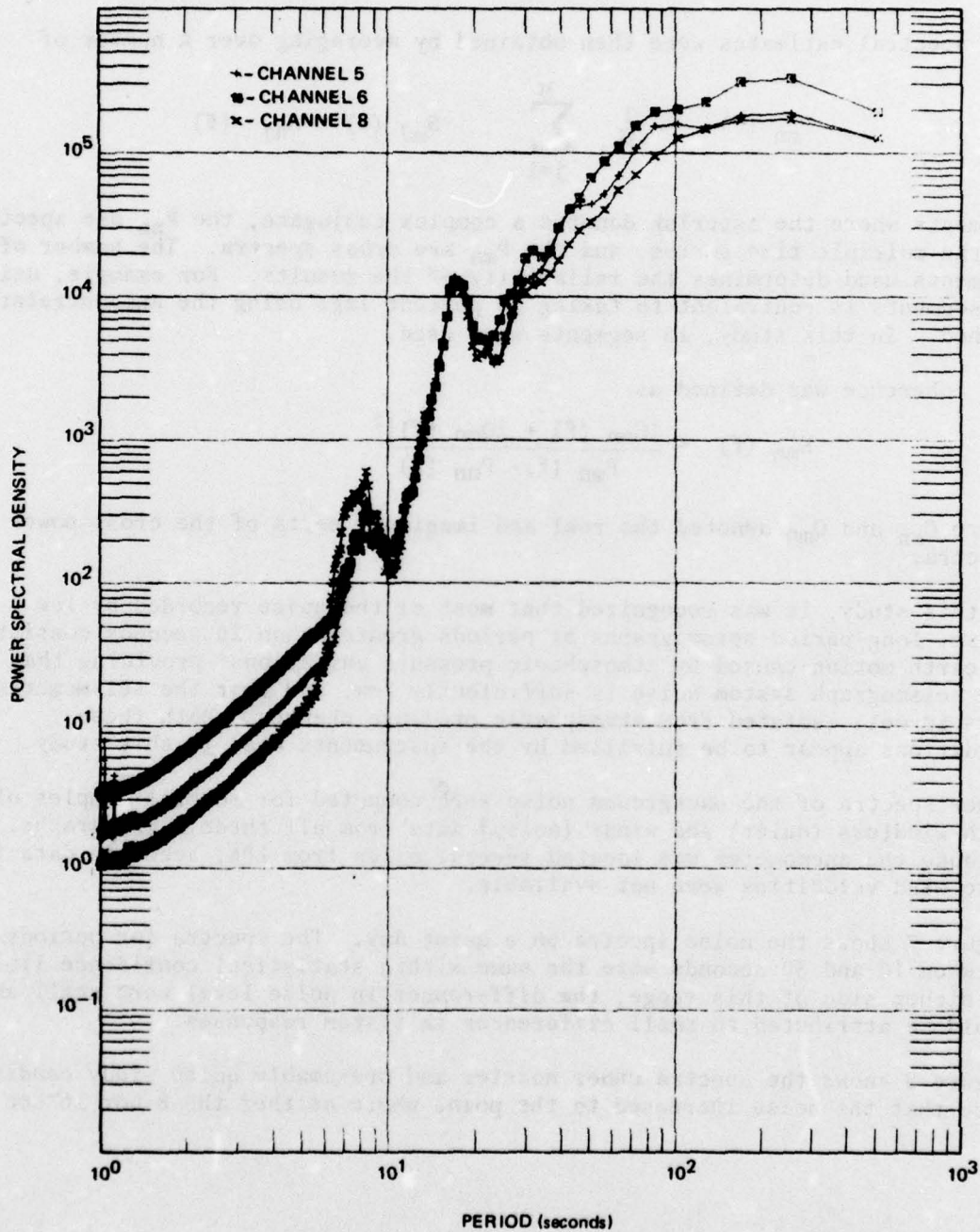

Figure 7. Power spectra of long-period horizontal seismograph noise sensed in three different tank vaults at LP6 during a quiet period

G 7804

11 APRIL 1974
2300/0134

18432 SAMPLES, 1024 BLOCK SIZE, 2 SPS
CHANNEL 5 MODEL 14414 (WITH BOTTOM)
CHANNEL 6 BOTTOMLESS
CHANNEL 8 LAMONT DOUGHERTY

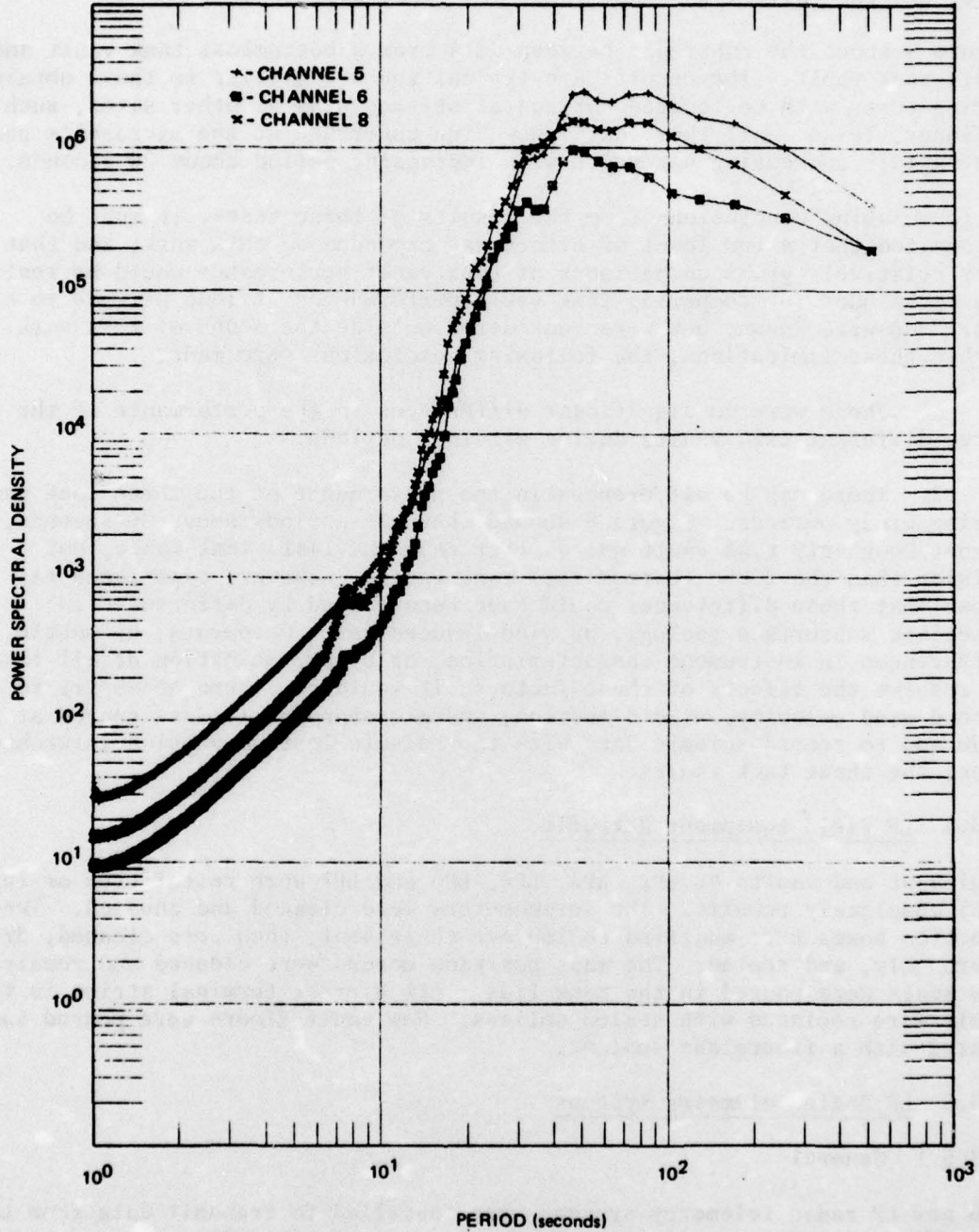

Figure 8. Power spectra of long-period horizontal seismograph noise sensed in three different tank vaults at LP6 during a noisy period

G 7805

microseisms are apparent in the spectra. The noise level on all three systems increased about the same amount, except for the periods greater than 30 seconds. The Lamont tank vault appears to have been the most affected by wind-induced noise and the bottomless tank vault the least affected.

Figure 9 shows the coherence between data from a bottomless tank vault and a 14414 tank vault. The results are typical and are similar to those obtained during tests with co-located horizontal seismographs at other sites, such as McKinney, Texas. All these data show high coherence at the microseism peaks and rapidly decreasing coherence with increasing period about 20 seconds.

In formulating conclusions from the results of these tests, it must be recognized that a low level of effort was expended on this work, and that only relatively gross comparisons of tank vault performance would be realized. The techniques for comparing tank vault performances at long periods to within 1 or 2 dB were known, but were considered outside the scope of this work. Within these limitations, the following conclusions were made.

1. There were no significant differences in the performance of the three different tank vaults during windless periods.

2. There may be differences in the performance of the three tank vaults during windy periods. Figure 8 showed that, at periods above 50 seconds, the Lamont-Dougherty tank vault was quieter than the 14414 tank vault, but noisier than the 29060 (bottomless) tank vault. However, experience has shown that these differences could have been caused by differences in immediate subsurface geology, by wind-induced earth movements, by subtle differences in instrument characteristics, or by a combination of all three. To resolve the effects of these factors, it would have been necessary to record wind velocity, wind direction, and microbarometric data sensed at the side and to record seismic data with the seismic instrumentation interchanged among the three tank vaults.

4.3.4 LP Field Equipment Retrofit

Equipment and vaults at LP2, LP3, LP4, LP6 and LP7 were retrofitted or (as in LP6) completely rebuilt. The seismometers were cleaned and checked. The junction boxes were modified to improve their seal, then were cleaned, dried thoroughly, and sealed. The mass position motors were cleaned and repaired. New seals were poured in the tank lids. All barrier terminal strips in the vault were replaced with sealed splices. New vault floors were poured and coated with a fiberglass sealant.

4.3.5 LP Radio Telemetry Systems

4.3.5.1 General

Two new LP radio telemetry systems were installed to transmit data from LP5 and LP7 to the CRB via relay equipment located at LP1. These new systems replaced the long spiral-4 cable line between LP7 and the CRB and the outdated, two-link radio system between LP5 and the CRB.

Field site preparation was begun after receipt of the executed copy of Amendment No. 9 to the Memorandum of Understanding No. LA-1412 between the

18432 SAMPLES, 1024 BLOCK SIZE, 2 SPS
CHANNEL 6 X 8

9 APRIL 1974
0320/0654

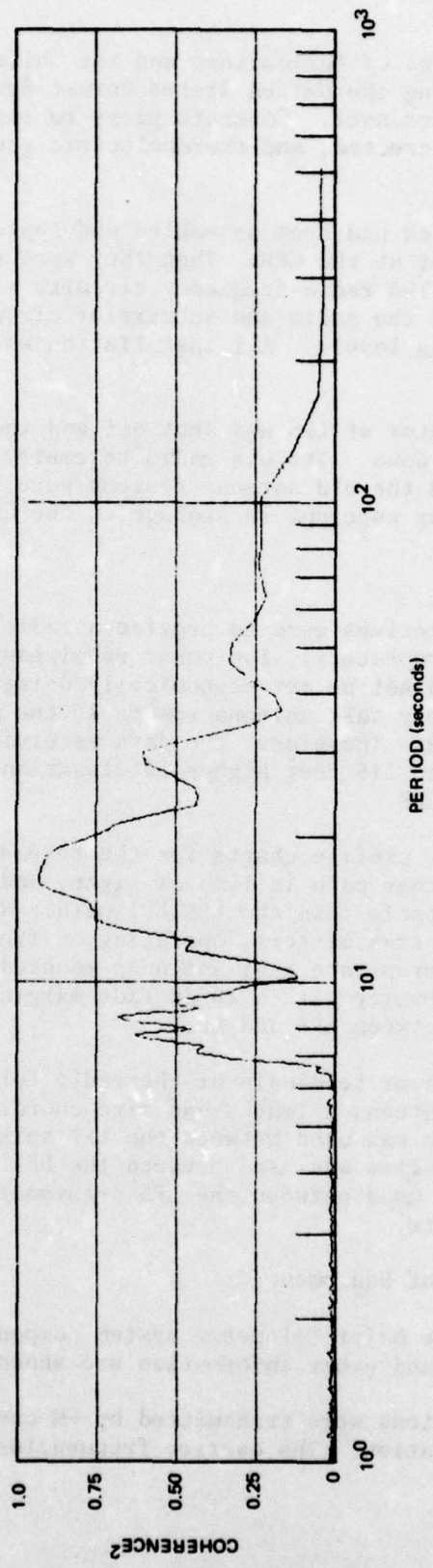

Figure 9. Coherence between long-period horizontal seismic noises sensed in a 14414 (with bottom) tank vault and those sensed in a bottomless tank vault at LP6 during a quiet period

G 7806

United States Department of Agriculture and the United States Air Force, and after coordination among the United States Forest Service, the Project Officer, and the Observatory personnel. Concrete piers to support the equipment were poured, antennas were erected, and thermoelectric generator power systems were installed.

The radio systems, which had been assembled and tested in Garland, were given a final laboratory test at the CRB. Then they were transported to the field sites and installed. The radio-frequency circuits were trimmed and tuned for maximum efficiency and the audio and subcarrier circuits were adjusted to their correct operating levels. All installation work was completed on 27 November 1973.

The Witte power generator at LP5 was shut off and the old dish antenna reflectors were taken down. The old radio telemetry equipment at Diamond Point was shut off and the old antenna systems were removed from the tower on 22 April 1974. They were put in storage at the CRB.

4.3.5.2 Design

The system design objectives were to provide a radio telemetry system with single-hop links (no repeaters), low power requirements, and good reliability. These objectives could not be met economically using commercially available equipment and reasonably tall antenna towers if the data receiving terminal were placed at the CRB. Therefore, the data receiving terminal was established at LP1, which is 115 feet higher in elevation than the CRB and is 1-1/4 miles from the CRB.

Figures 10 and 11 show profile charts for the telemetry system transmission paths. Note that neither path is line-of-sight, and that the LP7-LP1 path has a much larger obstacle than the LP5-LP1 path. Nevertheless, calculations predicted that 2-watt transmitters, operating on frequencies of approximately 140 MHz, and using appropriate Yagi antennas mounted on towers 40 to 50 feet high, would provide service with a 29 dB fade margin between LP7 and LP1 and a 43 dB fade margin between LP5 and LP1.

Figure 12 shows the major terminals of the radio telemetry circuits and figure 13 shows the antenna azimuths and site coordinates. Note that 0.4 mile of spiral-4 cable was used between the LP7 seismometer site and the LP7 telemetry site; 1.25 miles was used between the LP1 telemetry site and the CRB, and 1.0 mile was used between the LP5 seismometer site and the Chalk Mountain telemetry site.

4.3.5.3 Description of Equipment

A block diagram of the major telemetry system components is shown in figure 14. System circuits and other information are shown in figures 15 through 17.

All data and calibrations were transmitted by FM carriers that were deviated ± 5 kHz for 100% modulation. The carrier frequencies used are as follows:

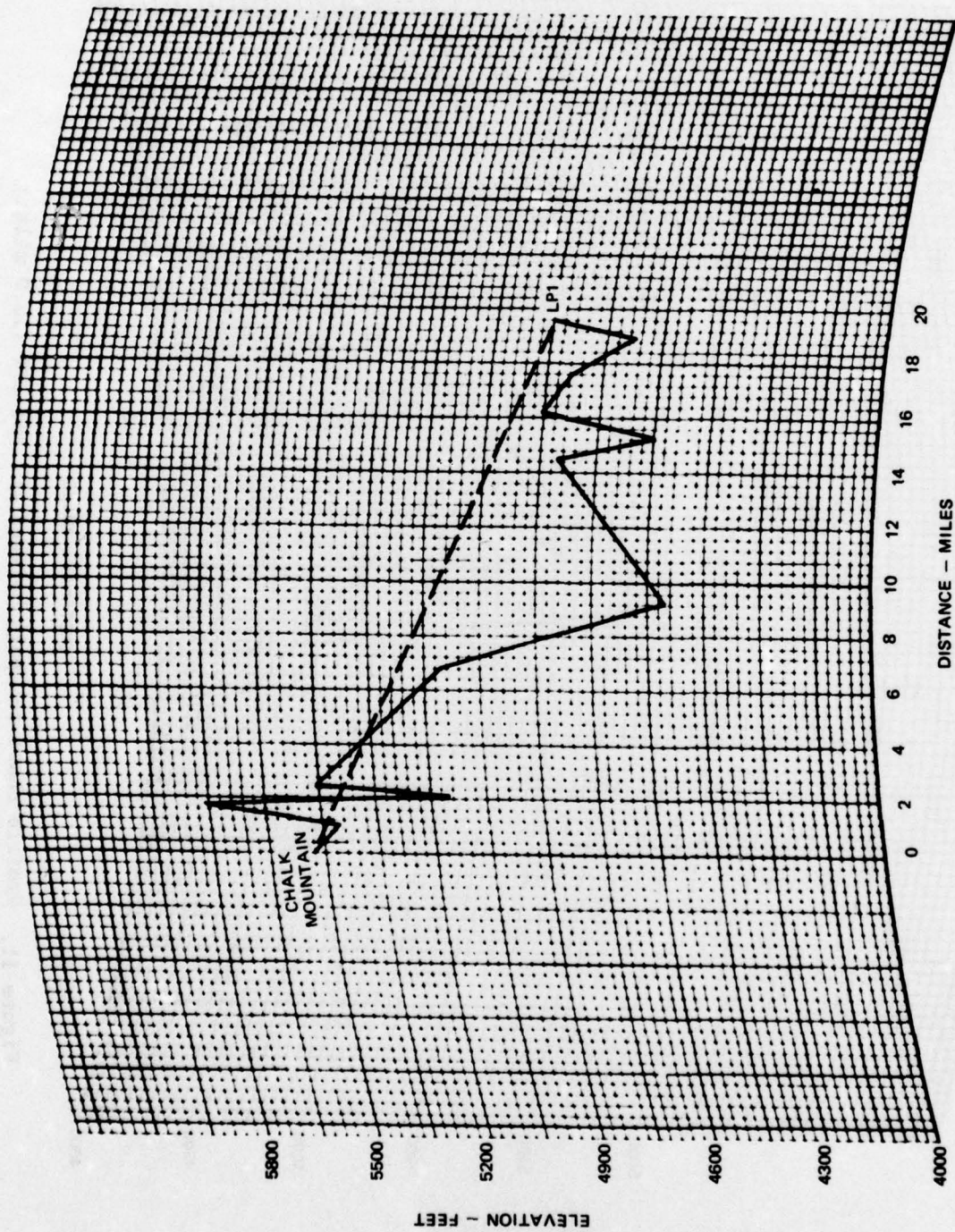

Figure 10. Profile chart for path between Chalk Mountain and LP1 (19.5 miles)

G 7442

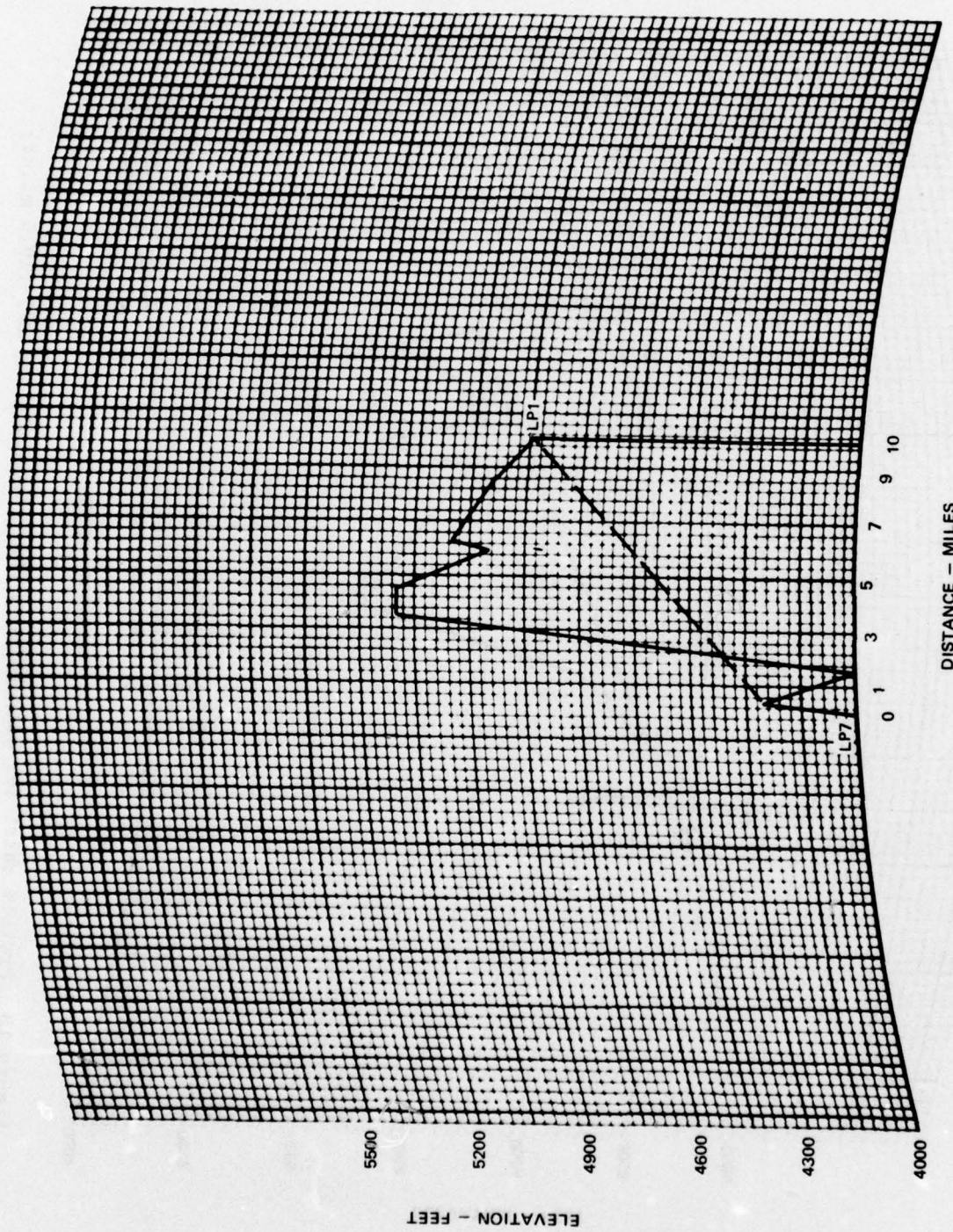

Figure 11. Profile chart for path between LP7 and LP1 (10.0 miles)

G 7443

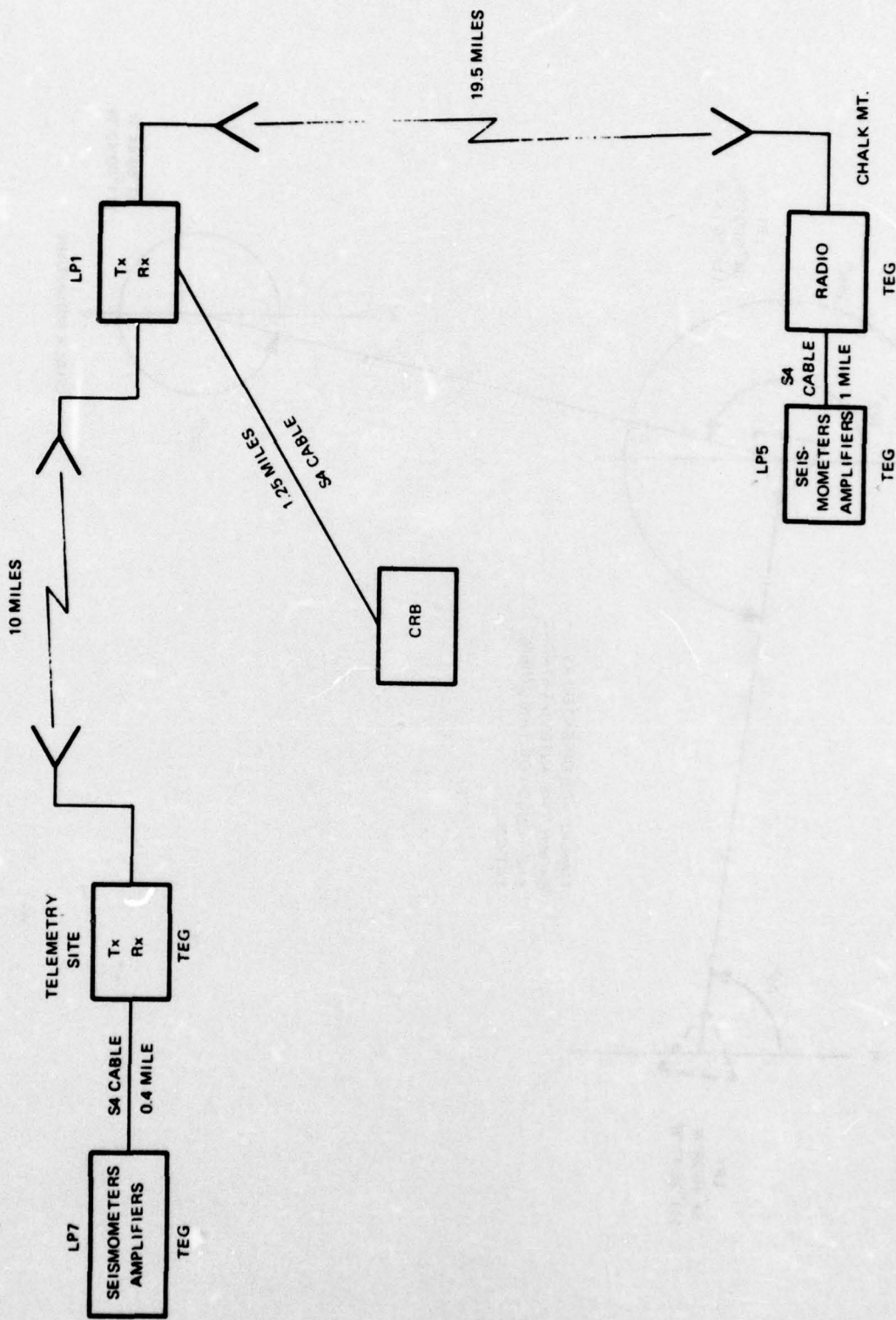

Figure 12. Major terminals of the TFSO LP radio telemetry circuits

G 7444

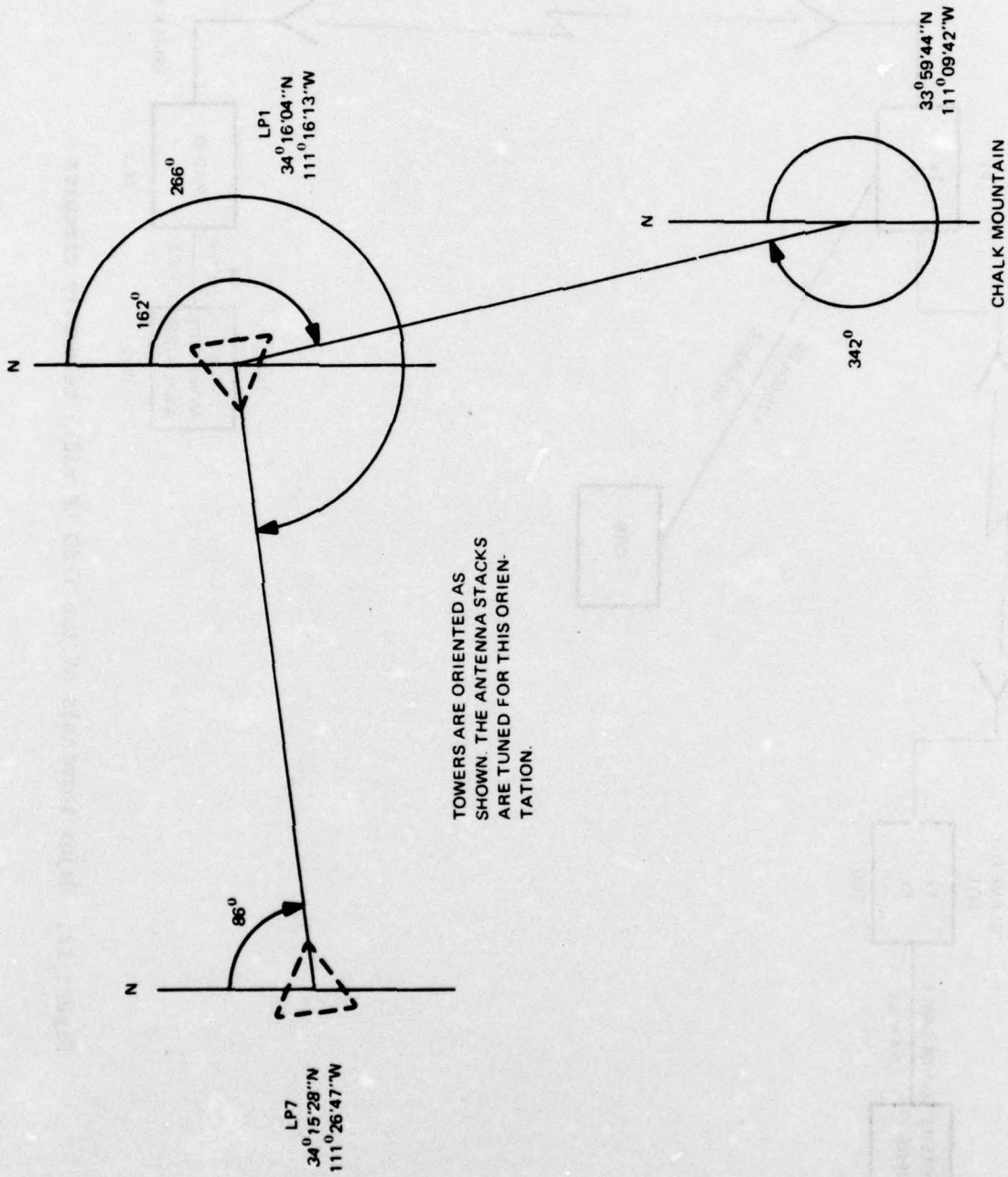

Figure 13. LP telemetry antenna azimuths

G 7445

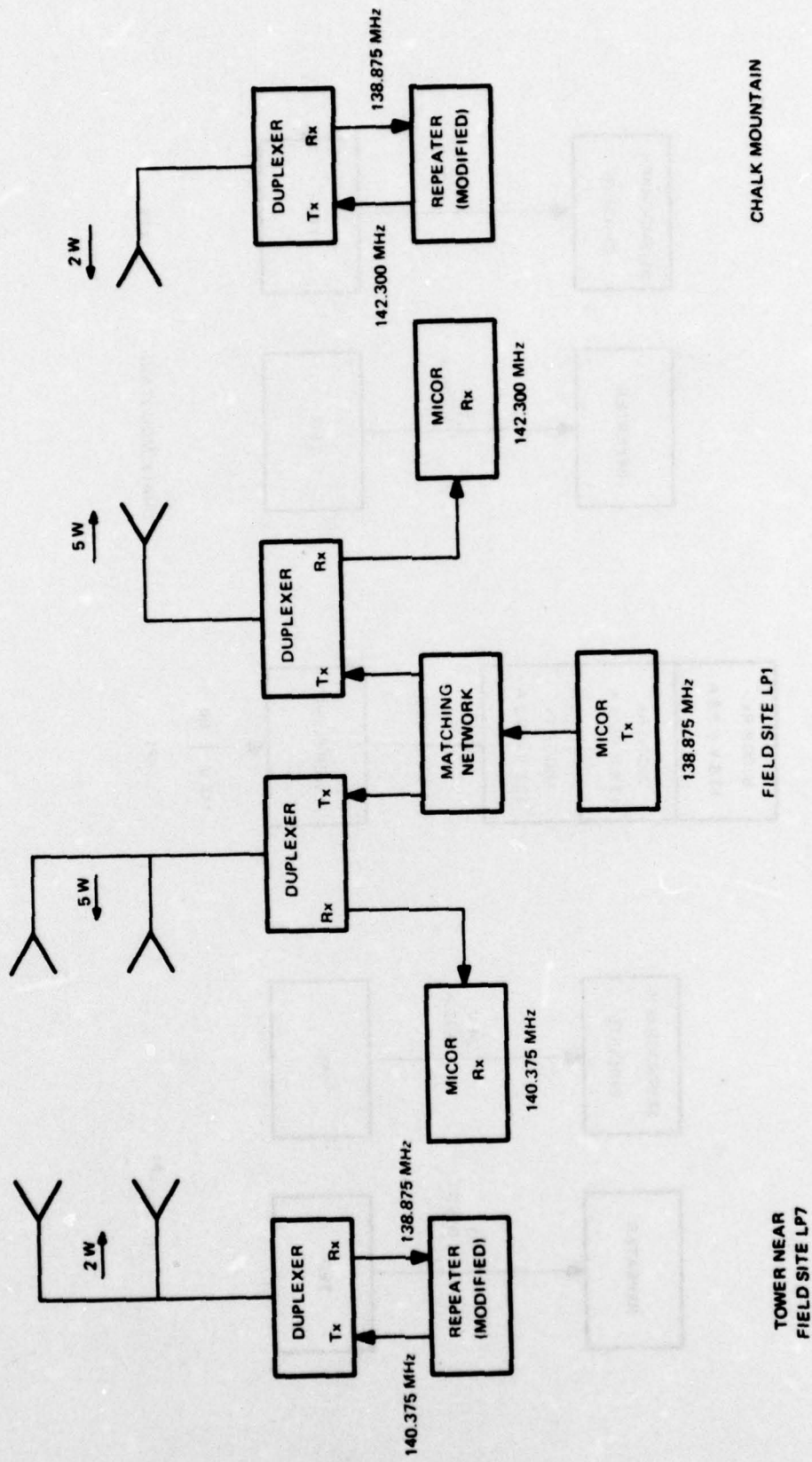

Figure 14. TFSO LP telemetry system

G 7446

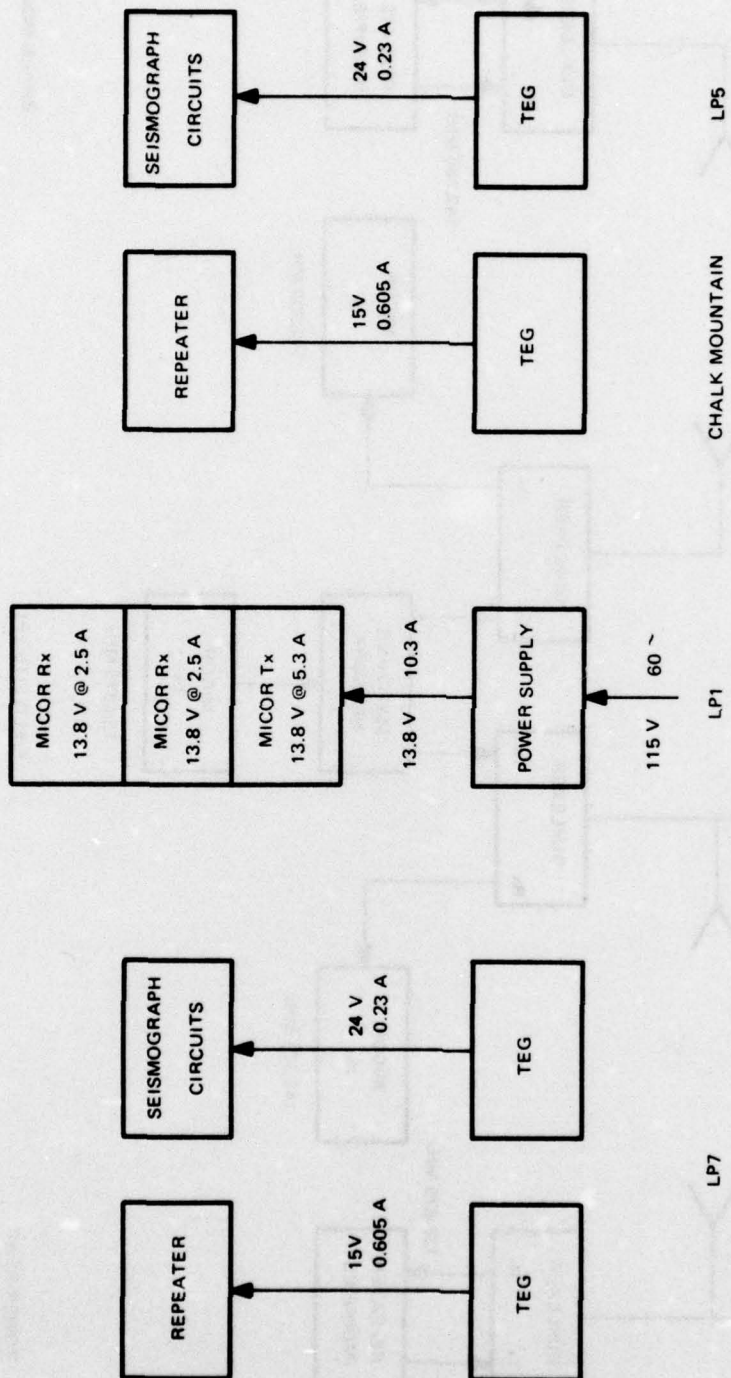

Figure 15. Power for LP telemetry circuits

G 7447

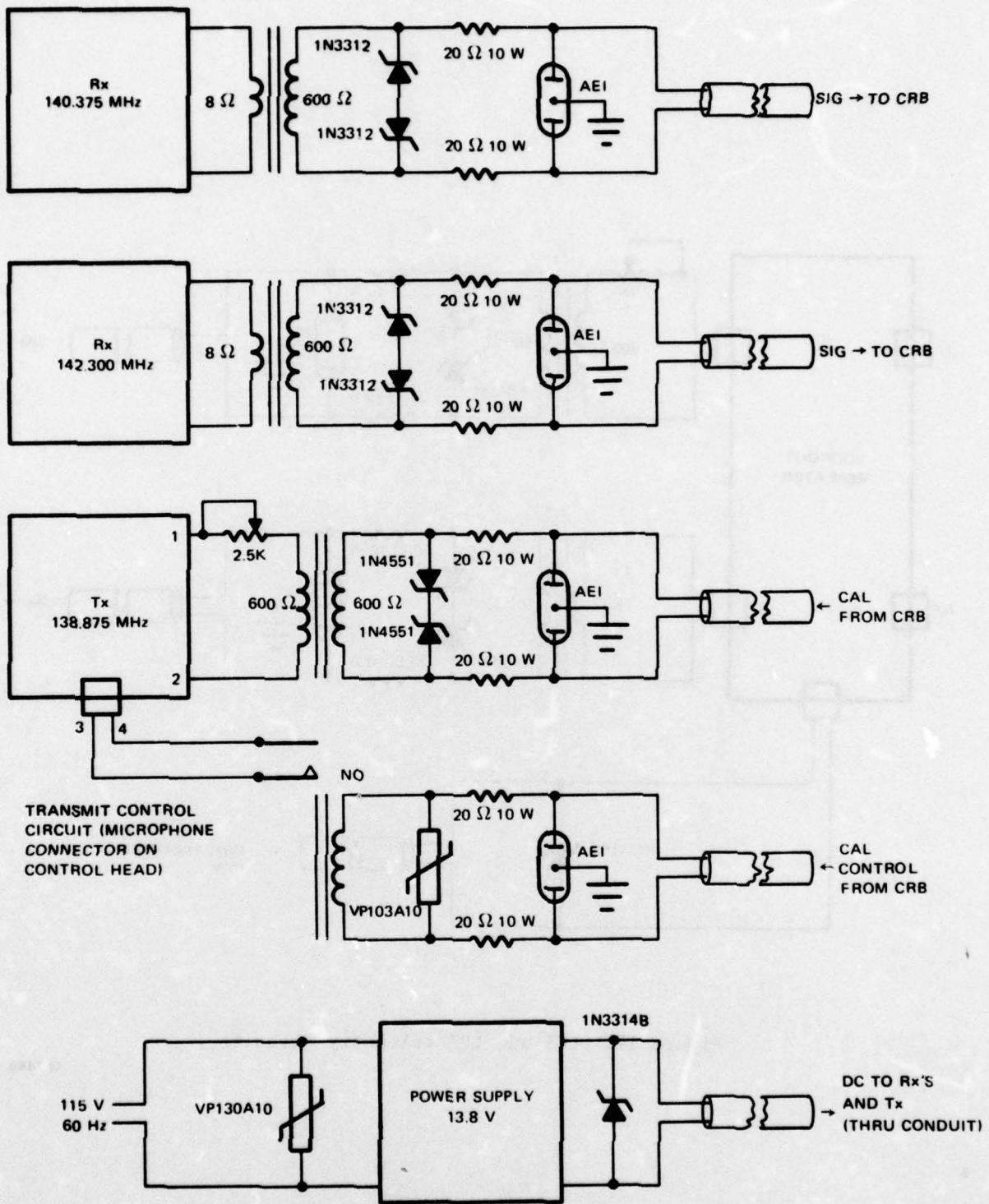

Figure 16. LPI radio telemetry circuits

G 7448

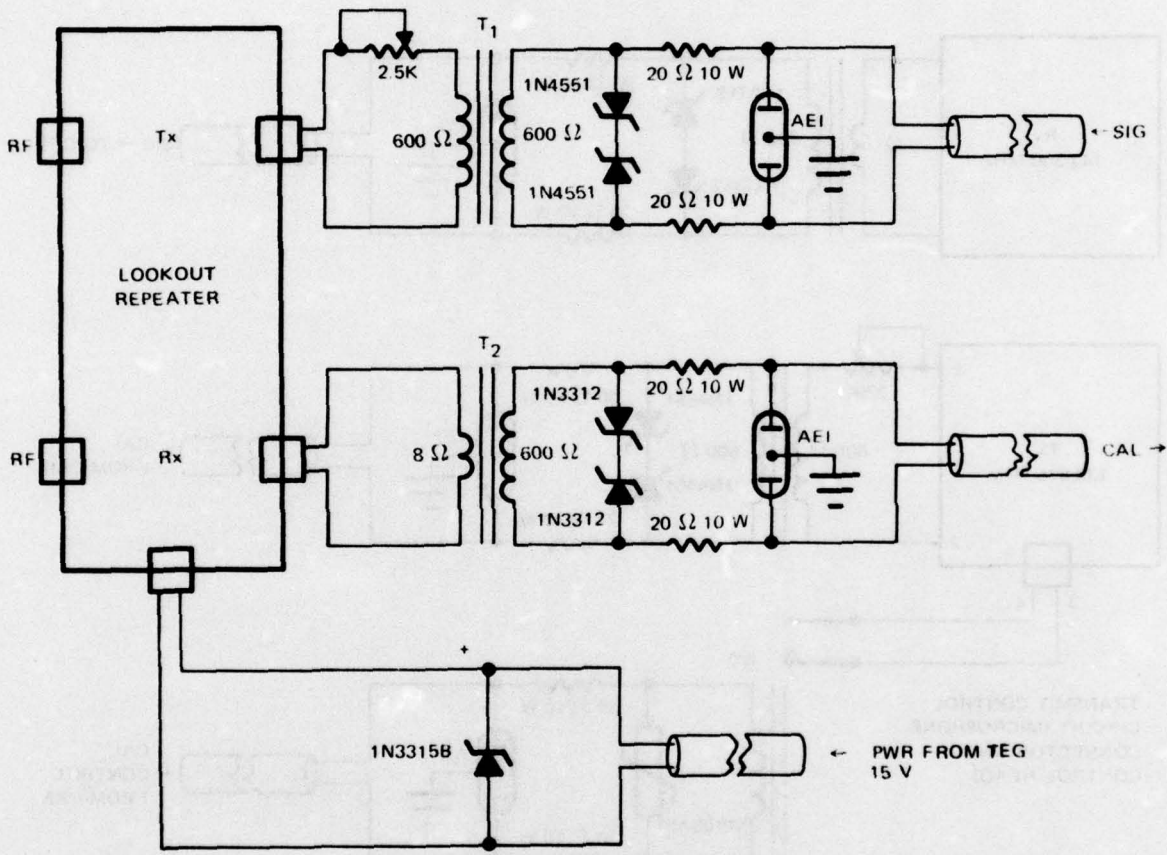

Figure 17. LP5 and LP7 telemetry circuits

G 7449

<u>From</u>	<u>To</u>	<u>Use</u>	<u>Frequency in MHz</u>
LP7	LP1	Data	140.375
Chalk Mountain	LP1	Data	142.300
LP1	LP7	Calibrations	138.875
LP1	Chalk Mountain	Calibrations	138.875

A Motorola Model 35134 Repeater, modified to permit simultaneous transmission and reception of separate data channels, was used at the LP7 telemetry site. The transmitter (Tx) output was rated at 2 watts, and the receiver (Rx) sensitivity was 0.5 μ V for 20 dB quieting. The Tx output and the Rx input were connected to the same antenna system through a Sinclair Model Q2B17G duplexer, which isolated the two circuits from each other and permitted full duplex operation. Signals were radiated and received by an antenna system made up of two stacked 6-element vertical Yagi antennas, Lone Star Electronics Model 138-144-6-U matched and phased with a quarter-wave line. The upper 6-element section was mounted on a Rohn 25G tower approximately 40 feet above the ground. The lower section was approximately 33 feet above the ground. The antenna system was protected from lightning by its supporting pole, which extended 2 feet above the top of the upper antenna. Voltages induced into the tower were bled off through a ground rod connected to the base of the tower.

As installed, an Isotopes Model 2TP12CL Thermoelectric Generator (TEG) furnished power for the LP7 telemetry equipment and a 3M Model 515 TEG furnished power for the LP7 seismograph circuits.

Figures 18 through 20 show the LP7 telemetry installation, the equipment at the tower base, and the equipment box interior.

On 14 November 1974, the power source for the LP7 telemetry equipment was changed from a TEG to a solar power source.

The radio telemetry installation at LP5, Chalk Mountain, was identical to that at LP 7 except as follows:

- a. A single 6-element vertical Yagi antenna, Lone Star Electronics Model 138-144-6-U, was mounted on top of the existing 30-foot tower.
- b. The radio equipment box was installed inside the existing wood frame shelter.

Figure 21 shows a photograph of the installation at Chalk Mountain.

The radio telemetry installation at LP1 used three Motorola Model T43RTN1100 Micor Mobile Radios. One unit received data from LP7, another received data from Chalk Mountain (LP5), and the third transmitted calibration data to both sites. The single Tx was connected to both antennas through a quarter-wave matching line and through duplexers which permitted simultaneous transmission and reception through both antenna systems. All radio equipment was installed in two weatherproof equipment boxes, which were mounted back-to-back on a supporting framework near the base of the tower. A plat of the LP1 fenced enclosure and the antenna tower is shown in figure 22. A photograph of the installation is shown in figure 23.



Figure 18. Radio telemetry installation near LP7

G 7450

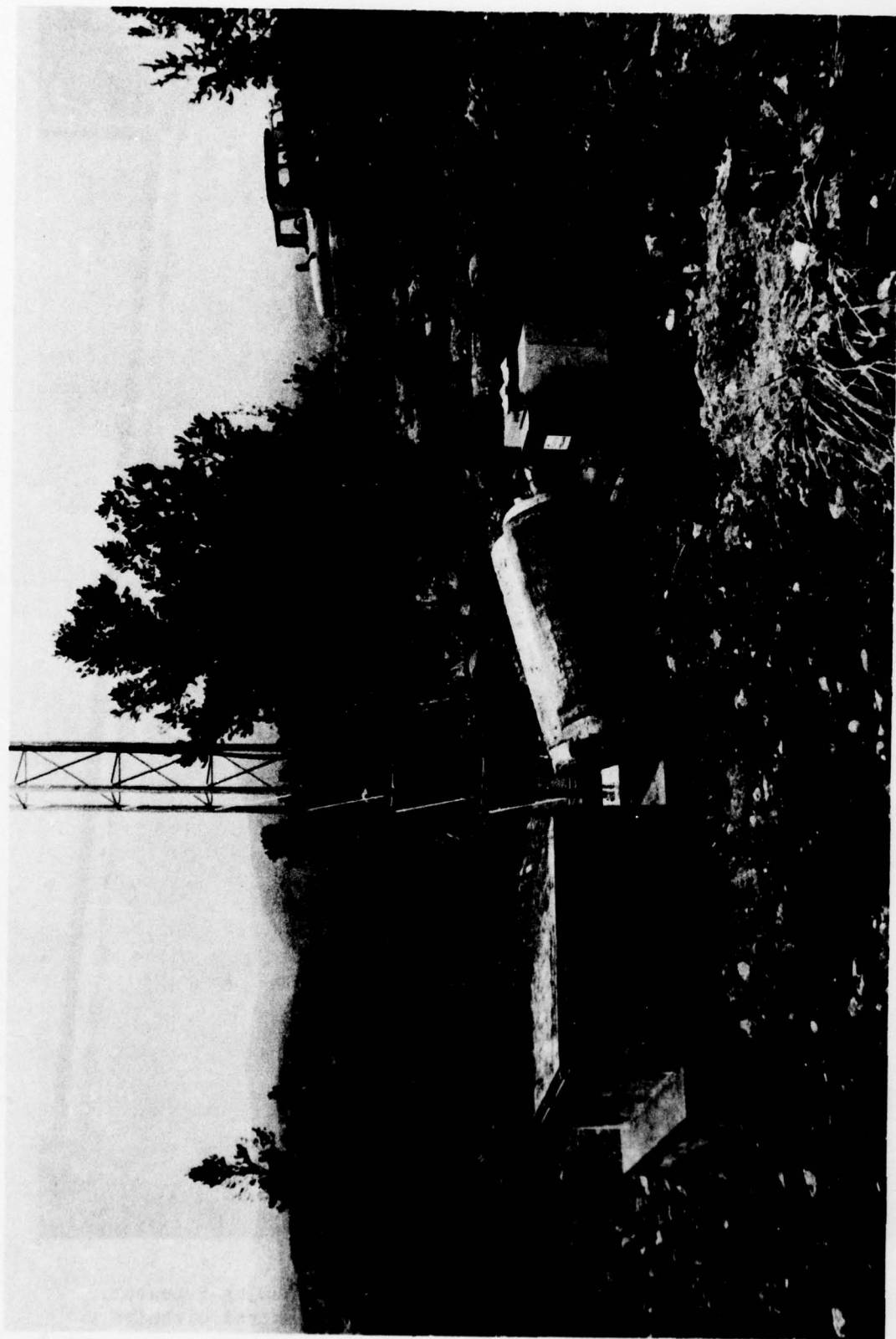

Figure 19. Telemetry equipment box base of antenna tower, propane tanks, and thermoelectric generator at LP7 telemetry site

G 7451

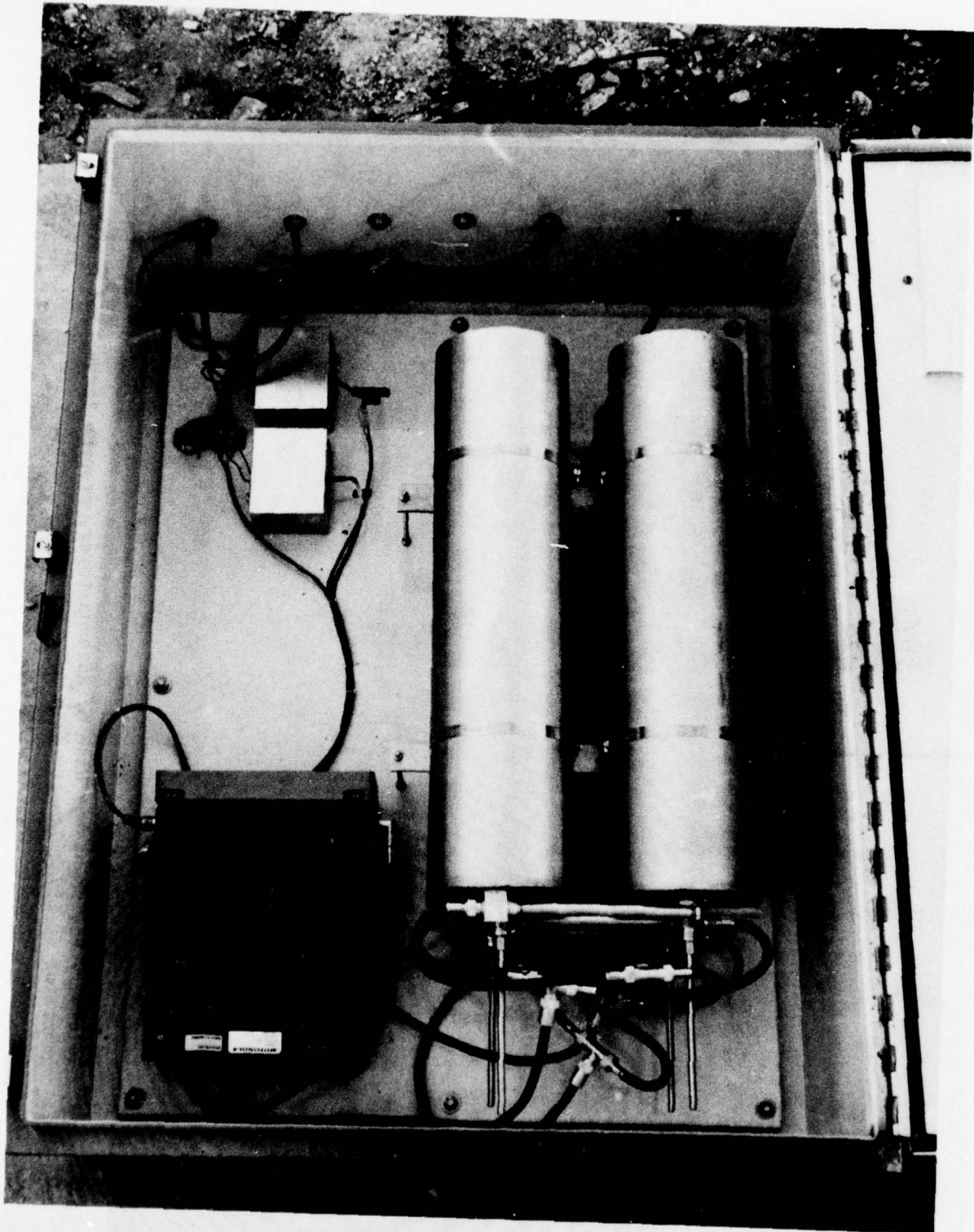

Figure 20. LP7 telemetry site equipment box open, showing repeater, duplexer, and lightning protection and control circuits

G 7452

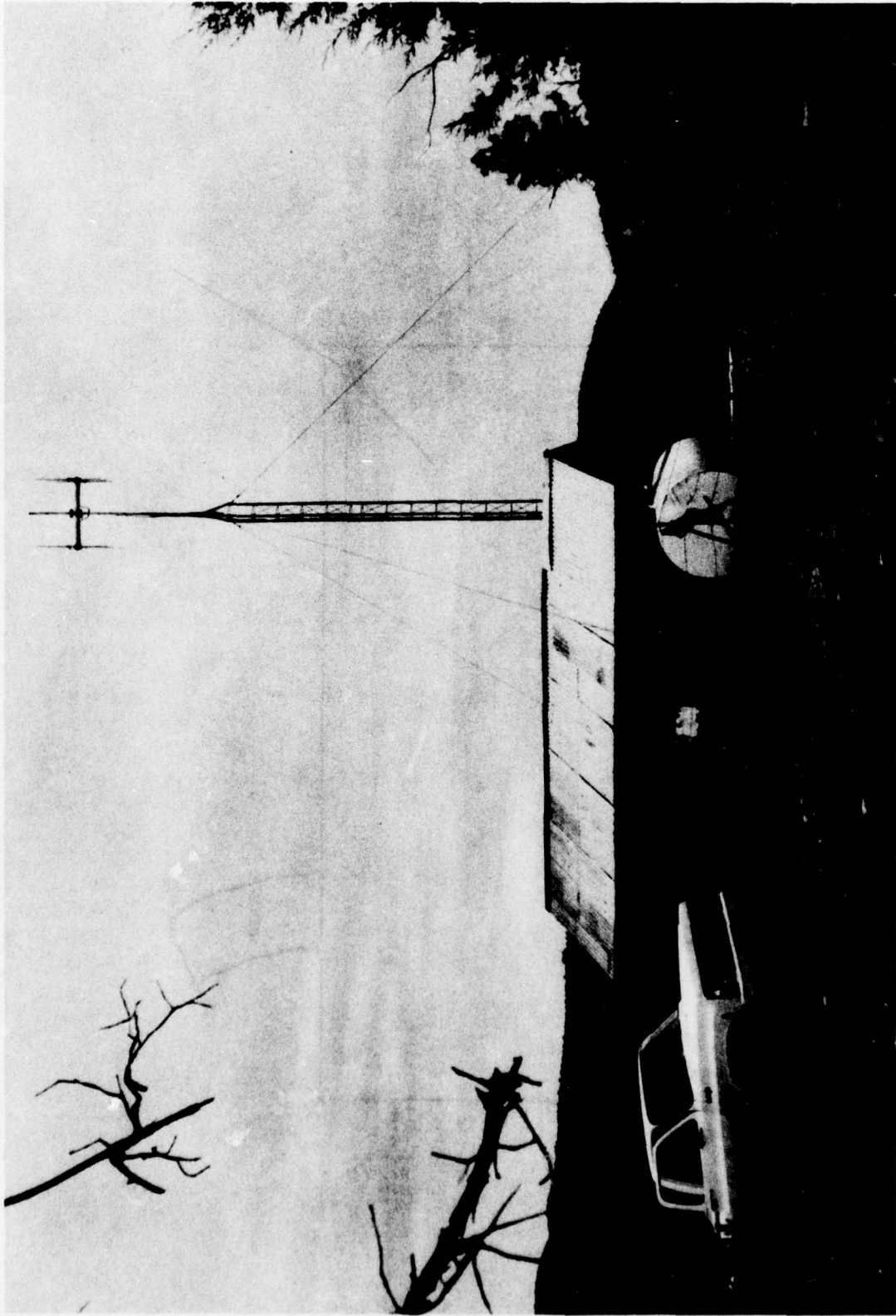

Figure 21. Radio telemetry installation at Chalk Mountain, LP5

G 7453

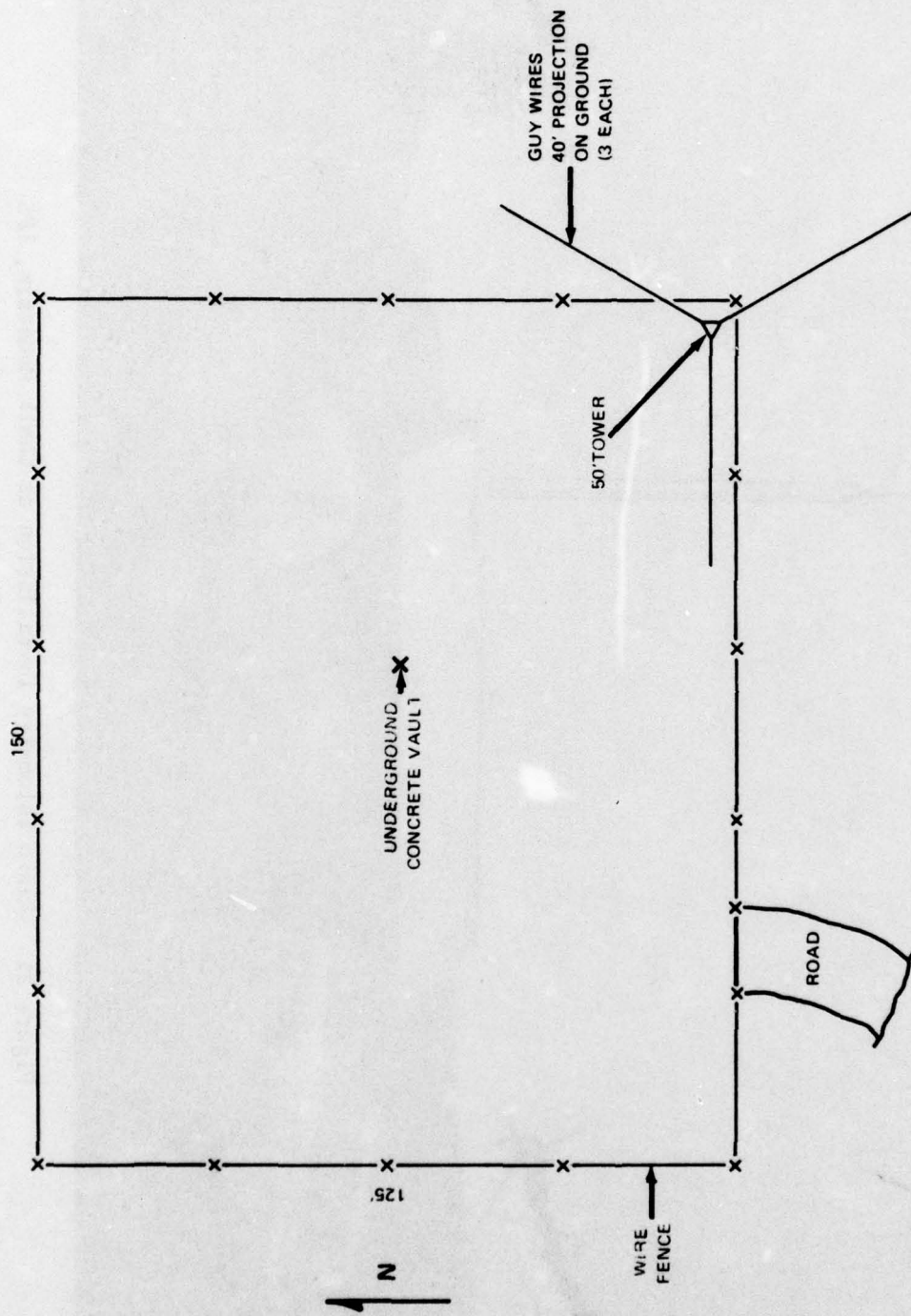

Figure 22. Plat of existing installation at LP1 with antenna tower superimposed

G 7454

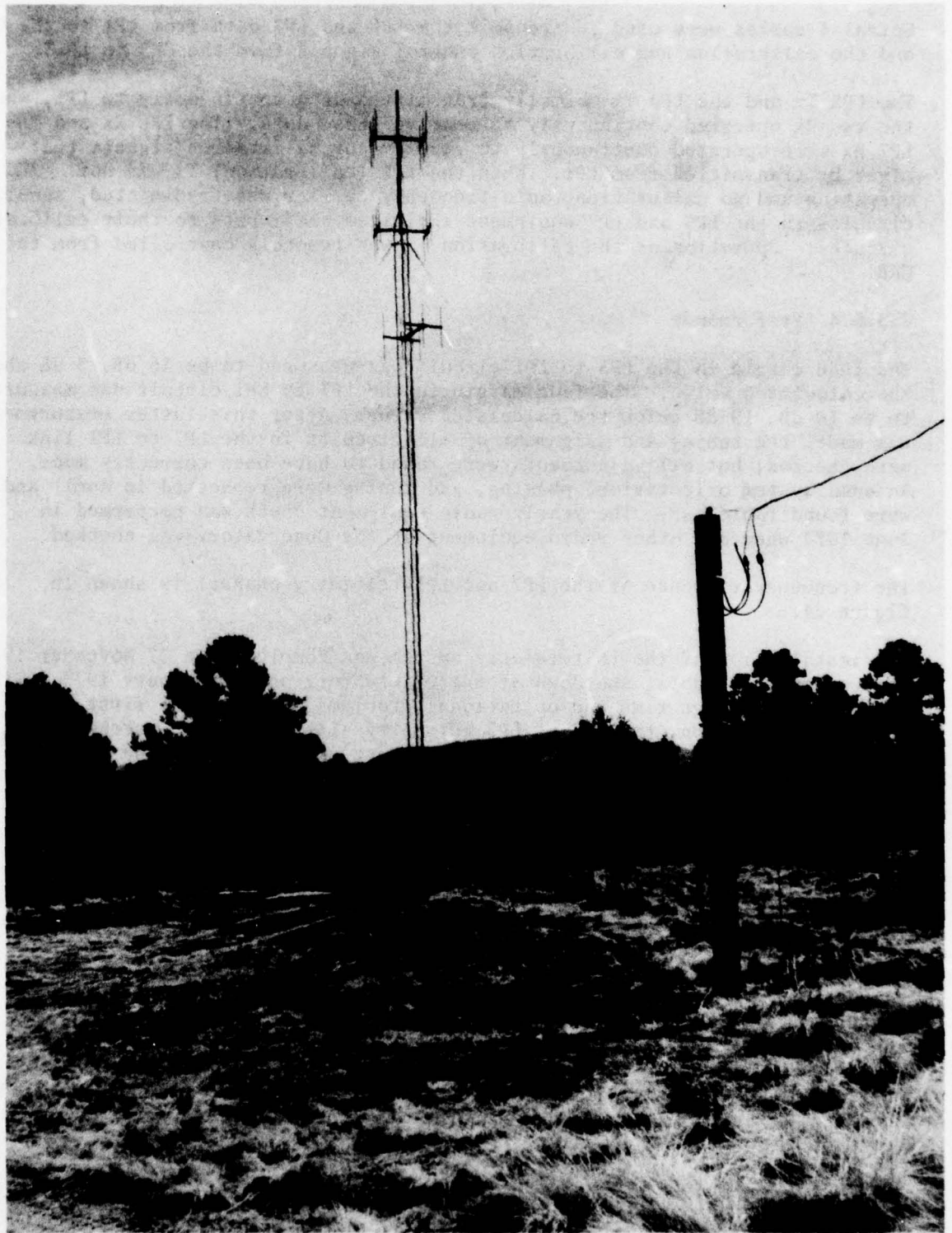

Figure 23. Radio telemetry installation at LP1

Spiral-4 cables were used to transmit the LP5 and LP7 data from LP1 to the CRB, and the calibration and calibration control signals from the CRB to LP1.

The LP5 Tx and the LP7 Tx normally transmitted data continuously to LP1, where the two Rx operated continuously to receive those data. The LP5 Rx and the LP7 Rx were operated continuously to receive any calibration signals that might be transmitted from LP1. When the LP1 (calibration) Tx was not operating and no calibration radio-frequency carrier was transmitted, squelch circuits in the LP5 and LP7 equipment inhibited all inputs to their calibration circuits. Operation of the calibration Tx was remotely controlled from the CRB.

4.3.5.4 Performance

The fade margin in the LP5 to LP1 circuit was measured to be 46 dB, 3 dB above the calculated value. The fade margin in the LP7 to LP1 circuit was measured to be 10 dB, 19 dB below the calculated value. After this latter measurement was made, the tuning and alignment of all circuits in the LP7 to LP1 link were checked, but all adjustments were found to have been correctly made. Antenna system orientation, phasing, and tuning were rechecked in April and were found faultless. The yearly radio equipment check was performed in June 1974 when all other radio equipment at the Observatory was checked.

The frequency response of the LP7 and LP1 telemetry channel is shown in figure 24.

The installation of the LP telemetry system was completed on 27 November 1973 and was operated until shutdown of the Observatory on 28 February 1975, with a minimum of outage time and operational problems. During the first few months of operation, the TEG at LP5 telemetry site flamed out several times because of water in the lines and once because a leak drained the fuel supply. The ac/dc power supply at LP1 blew fuses until its overvoltage protector circuit was modified.

In August of 1974, the radio telemetry transmitter at LP7 failed and was repaired by Canyon States Communications Company. A malfunction in the LP7 radio receiver located at LP1 was corrected by wiring around a faulty antenna switch on 14 August 1974. A check of the LP7 radio signal strength at the LP1 receiver indicated an increase of approximately 20 dB over previous levels measured. The gain in signal strength was probably due to repairs made on both the LP7 transmitter and receiver. The most recent measurements show signal strength at the LP5 receiver to be +14 dB and the LP7 signal to be +10.5 dB.

On 12 February 1974, the power source at the LP5 telemetry site was changed from TEG to a solar power system in order to conduct operational field tests of the new power system.

4.4 BROADBAND SEISMOGRAPH

After operating for several years without test or adjustment, the vertical broadband seismograph (Z39BB) was inspected and tested on 31 May 1974. A

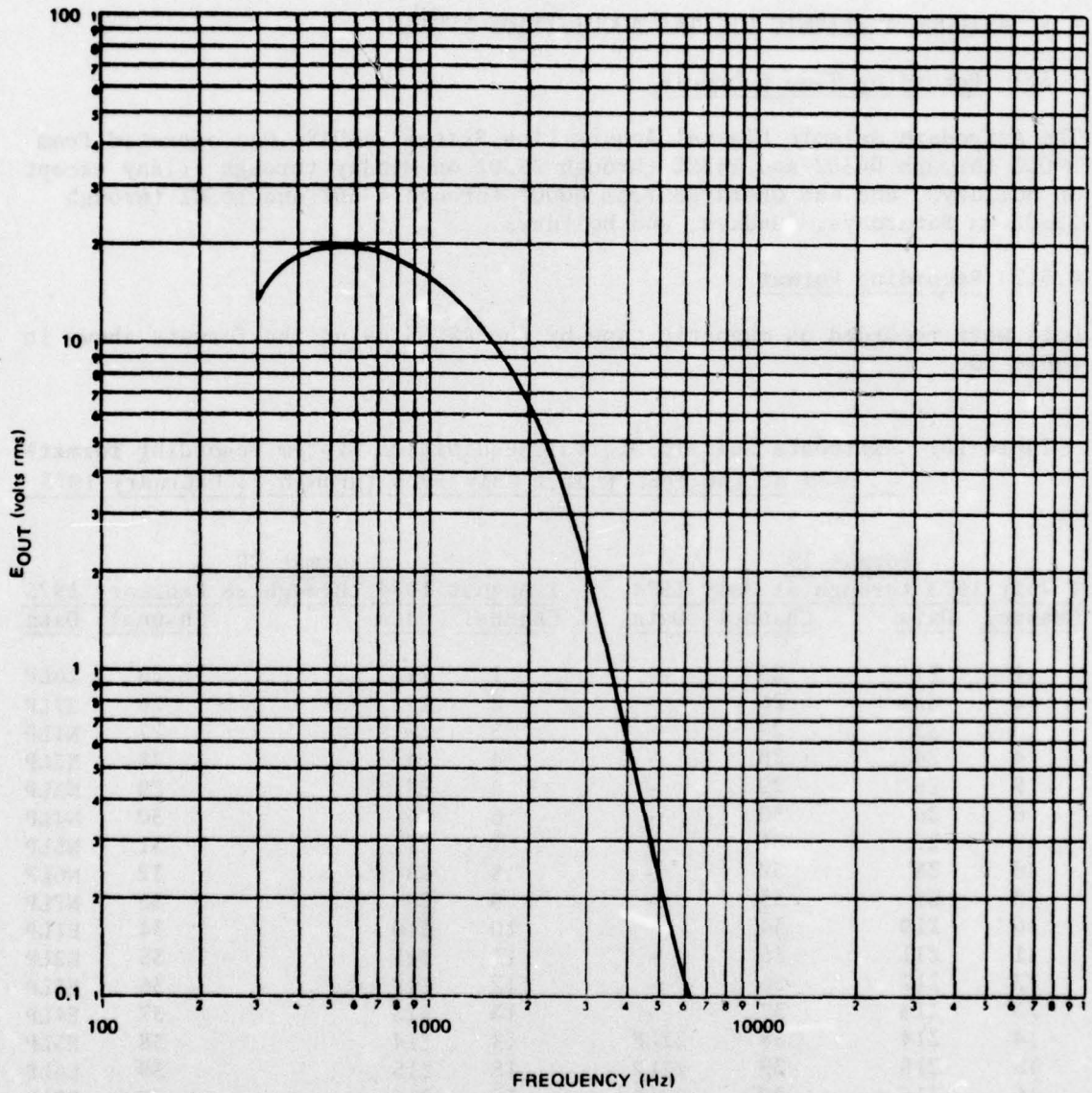

Figure 24. Response of LP7 telemetry system

G 7456

broken hinge was found and replaced. The instrument motor constant, initially measured as 0.176 N/Z, was adjusted to 0.184 N/A. The seismometer natural period was set to 12.5 seconds. On June 13, after tests showed that the channel frequency response was out of tolerance, the seismometer free period was changed to 12.0 seconds. This brought the frequency response into tolerance.

4.5 ASTRODATA SEISMIC DIGITAL ACQUISITION SYSTEM

4.5.1 Recording Time Schedule

The Astrodata Seismic Digital Acquisition System (ASDAS) was operated from 0000Z through 0430Z and 1425Z through 2330Z on Monday through Friday except on holidays, and was operated from 0000Z through 0430Z and 1630Z through 2230Z on Saturdays, Sundays, and holidays.

4.5.2 Recording Format

Data were recorded on magnetic tape by the ASDAS using the formats shown in table 10.

Table 10. Astrodata Seismic Digital Acquisition System recording formats used at the TFSO from 1 July 1973 through 28 February 1975

<u>Format 19</u>				<u>Format 20</u>			
<u>1 July 1973 through 31 July 1974</u>		<u>1 August 1974 through 28 February 1975</u>		<u>1 August 1974 through 28 February 1975</u>		<u>1 August 1974 through 28 February 1975</u>	
<u>Channel</u>	<u>Data</u>	<u>Channel</u>	<u>Data</u>	<u>Channel</u>	<u>Data</u>	<u>Channel</u>	<u>Data</u>
1	Z1	25	-	1	Z1	25	Z6LP
2	Z2	26	-	2	Z2	26	Z7LP
3	Z3	27	-	3	Z3	27	N1LP
4	Z4	28	-	4	Z4	28	N2LP
5	Z5	29	-	5	Z5	29	N3LP
6	Z6	30	-	6	Z6	30	N4LP
7	Z7	31	-	7	Z7	31	N5LP
8	Z8	32	-	8	Z8	32	N6LP
9	Z9	33	-	9	Z9	33	N7LP
10	Z10	34	-	10	Z10	34	E1LP
11	Z11	35	-	11	Z11	35	E2LP
12	Z12	36	-	12	Z12	36	E3LP
13	Z13	37	-	13	Z13	37	E4LP
14	Z14	38	Z1LP	14	Z14	38	E5LP
15	Z15	39	Z2LP	15	Z15	39	E6LP
16	Z16	40	Z3LP	16	Z16	40	E7LP
17	Z17	41	Z4LP	17	Z17	41	-
18	Z18	42	Z5LP	18	Z18	42	-
19	Z19	43	Z6LP	19	Z19	43	-
20	Z20	44	Z7LP	20	Z1LP	44	-
21	-	45	ZXLP	21	Z2LP	45	-
22	-	46	BS 9	22	Z3LP	46	-
23	-	47	FSH	23	Z4LP	47	ML-1
24	-	48	STS	24	Z5LP	48	STS

4.5.3 Operation and Maintenance

The ASDAS was operated routinely with interruptions only for tape change, scheduled maintenance, and repairs. Adjustments were made to vacuum controls, the capstan rollers, and the head alignment. Components requiring replacement included vacuum motor brushes, capstan drive belts, switches, and several electronic components.

4.6 DIGITAL GAIN-RANGING DATA ACQUISITION SYSTEM

The operation of the Digital Gain-Ranging Data Acquisition System (DGRDAS) was normally interrupted during this report period for record change, scheduled maintenance, and for troubleshooting the system. Two types of operational faults occurred intermittently, but only on specific channels. One involved the clipping of calibration signals, and the other involved channels becoming inoperative and assuming random dc levels for short periods of time. Both malfunctions were found to be related to out-of-specification performance of the binary-gain-ranging amplifier and its associated multiplexer and A/D converter.

During July 1974, these malfunctions increased and the quality of the magnetic-tape records deteriorated to a point where the data were unreliable. Intermittent maintenance was performed to return tape record lengths and interrecord gap lengths to their correct values, and routine operation was maintained until 29 August 1974 when it was taken off line for modifications.

A new Control and Acquisition Subsystem (CAS) incorporated a modern multiplexer (MUX), binary-gain amplifier (BGA), analog-to-digital converter (ADC), and level shift interfacing circuits. These were installed to replace old experimental circuits which were state-of-the-art in 1968, and which had deteriorated sufficiently to make the DGRDAS inoperative. In the old circuits, the MUX used unprotected MOS transistors, which were easily damaged, the BGA was marginally stable at best, and the ADC was overly sensitive to spurious noise spikes. The new CAS had none of these deficiencies.

A long elapsed time was spent in debugging the new CAS because a relatively low priority of effort was applied to the task. During debugging work, one defective integrated circuit was replaced, the circuit was modified to better utilize the functions available from the remainder of the DGRDAS, and the power supply and interface threshold voltage were adjusted. Debugging was completed in February 1975.

5. INSTRUMENT EVALUATION

5.1 MULTICHANNEL FILTER

The multichannel filter (MCF) was operated routinely until 9 August 1973, when it failed. When simple circuit tests did not locate the component failure, extensive troubleshooting was deferred until the advent of bad weather, when outdoor work could not be undertaken. In March 1974, all operations with the MCF were discontinued and the instrument was disconnected from the Observatory circuits.

5.2 HYGROMETER

On 23 January, a hygrometer was installed in the CRB main operating room near the recording thermometer. Relative humidity readings were taken and recorded three times per day. These data provided information concerning the environment in which the CRB instrumentation operated.

5.3 GRAVITY FEED CHEMICAL SUPPLY SYSTEM

The gravity-feed chemical supply system for the Observatory Developocorders was operated throughout the report period. The following is a listing, by month, of the chemical flow failures and the chemical usage rates:

<u>Month</u>	<u>Number of failures</u>		<u>Chemical usage - diluted gallons</u>		
	<u>Developer</u>	<u>Fixer</u>	<u>LP Developer</u>	<u>SP Developer</u>	<u>Fixer</u>
July 1973	0	0	8	8	15
August	0	0	8	8	15
September	0	0	5	6	11
October	0	0	5	8	9
November	0	0	6	7	11
December	0	0	6	7	12
January 1974	0	1	8	8	12
February	0	1	9	13	15
March	1	3	10	12	15
April	0	1	8	9	18
May	0	0	10	12	12
June	0	0	8	9	19
July	0	0	7	12	12
August	0	0	7	9	12
September	0	0	6	12	13
October	0	0	8	9	12
November	0	0	13	6	12
December	0	0	11	9	18
January 1975	0	0	7	7	15
February	0	0	6	6	15
Totals	1	6	156	177	273

Masses of what appeared to be algae appeared occasionally in the fixer lines and were flushed away before they interrupted the flow of chemicals. All system failures appear to have been caused by deposition of a whitish precipitate in the flow rate control valves.

5.4 FIELD INSTRUMENT POWER SYSTEMS

5.4.1 General

Most remote sensor sites at the TFSO and other seismological observatories have used power generated by commercial electric companies. The remaining sites, those in extremely isolated areas, have used power generated by fossil-fueled generators located at the sites. The generators have included propane-fueled thermoelectric generators, diesel-motor driven generators, and gasoline-motor driven generators. In view of the recent fossil-fuel crisis, the future usefulness of these generators has become questionable and alternate sources of power for field instrumentation have been investigated.

5.4.2 Solar Power

One of the more promising devices, a solar power supply, was procured for test and evaluation. A version appropriate for powering the telemetry system at Chalk Mountain was chosen because this site was difficult to supply with fuel, and because a suitable shelter was available there for supporting the light energy converter (LEC) and housing the storage batteries used in the supply.

Figure 25 shows a schematic diagram of the power system installed at Chalk Mountain. The LEC, the battery, and the regulator comprised the Solar Power Supply, Model 18-3.3-W200, furnished by the Spectrolab Division of Textron. The 1-ohm resistor and the Zener diode were added later to limit battery charge.

The LEC was specified to produce 3.3 amperes when illuminated with 100 mW/cm² of sunlight at a temperature of 25°C. It consisted of an array of plastic-encased photovoltaic semiconductor cells mounted in an aluminum frame equipped with hinged, adjustable supports. The array was pointed south with the angle between the array plane and true horizontal set equal to the installation latitude. At Chalk Mountain, this was installed on the shed roof as shown in figure 26. Coincidentally, the roof peak ran east-west, making the LEC orientation simple. The array tilt was adjusted to 34° above horizontal.

The battery consisted of nine, 2-volt, lead-acid cells with a 220 ampere-hour capacity. These were charge-retaining cells which had a standing loss of only 15% of capacity per year at 80°F. To provide performance over long periods in adverse environments such as cloudy days, dirt and heavy snow on the LEC array, and low temperatures, the solar power supply had a large reserve capacity. Under ideal conditions (temperature = 25°C, sunlight = 100mW/cm², and clean LEC's), the LEC could fully charge the battery in 80 sunlight hours while powering the radio telemetry equipment. A fully charged battery could power the radio-equipment for more than 350 hours of darkness. The battery was installed inside the shed on the concrete floor. It was protected against cold with fiber-glass insulation, and against rain by a plastic sheet cover.

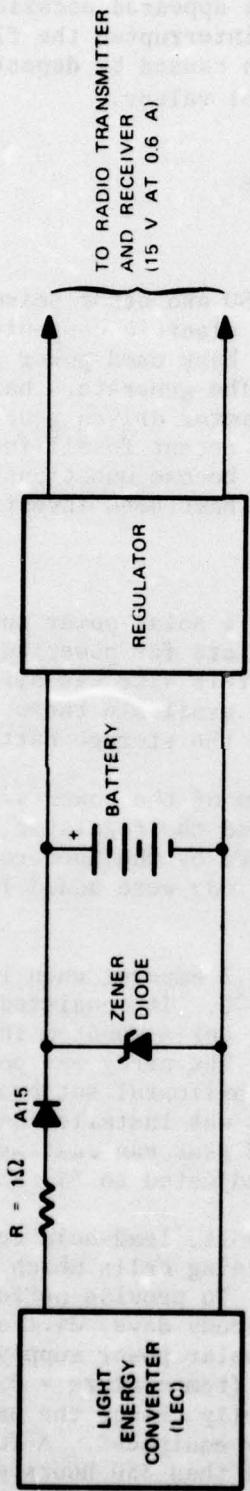

Figure 25. Schematic of Chalk Mountain solar power supply

G 7457

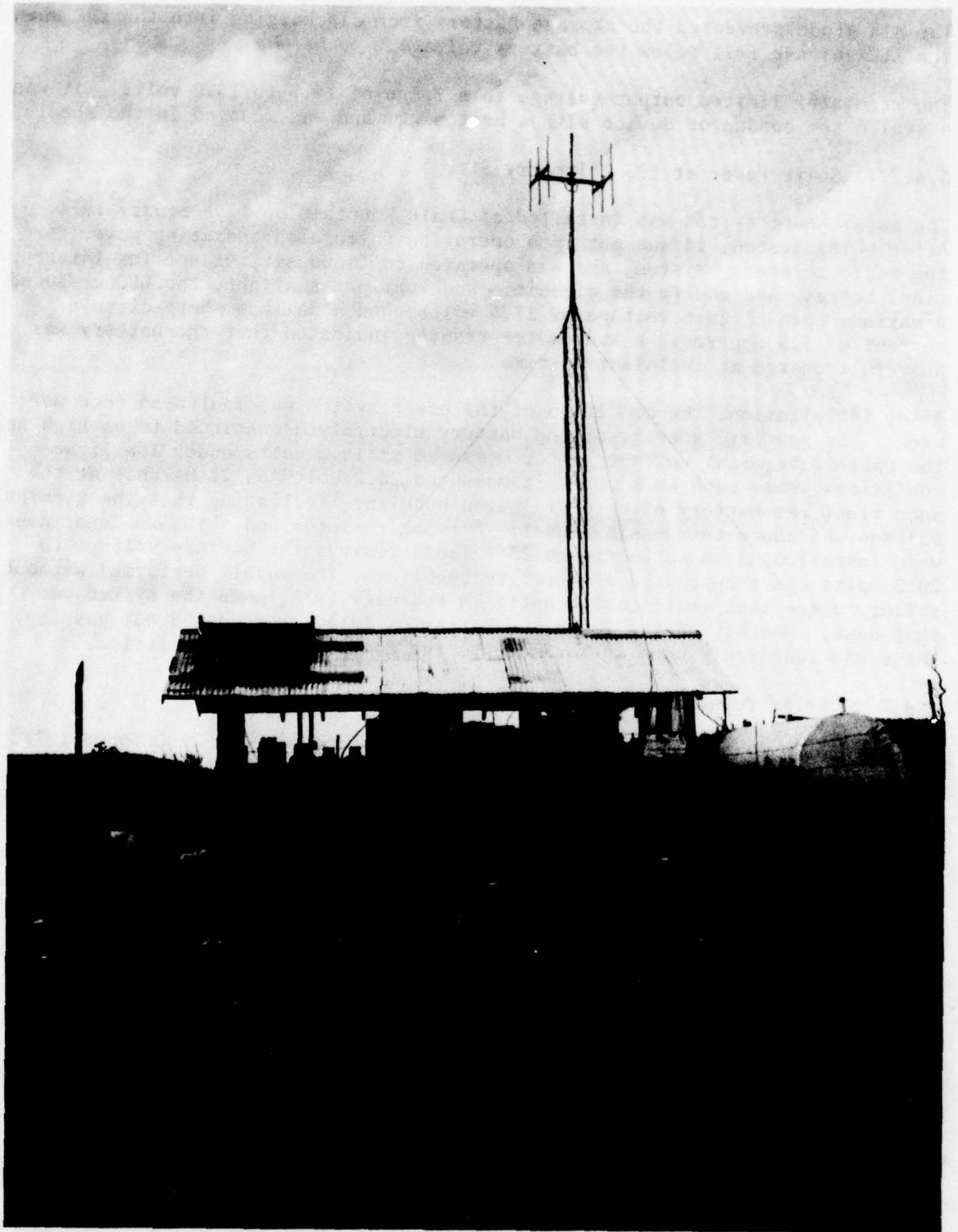

Figure 26. Chalk Mountain telemetry station with solar power supply

G 7458

The A15 diode prevented the storage battery from discharging into the LEC when the LEC voltage fell below the battery voltage.

The regulator limited output voltage to a range of 14.5 to 15.0 volts. It was a sealed semiconductor device with a heat sink, and was mounted in the shed.

5.4.2.1 Solar Power at LP5 Telemetry Site

The solar power system was installed at Chalk Mountain on 12 February 1974. After being tested, it was put into operation to furnish operating power for the radio telemetry system, and was operated continuously, except for interruptions to test and modify the circuit. Under bright sunlight, the LEC produced a maximum open-circuit voltage of 37.5 volts, and a maximum short-circuit current of 3.5 amperes. A hydrometer reading indicated that the battery was near full charge at installation time.

After installation, the condition of the power system was monitored once per week. The specific gravity of the battery electrolyte continued to be high and the battery terminal voltage, first measured at 18.2 volts under low light conditions, rose each week until it measured 24.2 volts on 22 March. At the same time, the battery electrolyte began bubbling, indicating that the terminal voltage was above the gassing level. A 1-ohm resistor and a 1N3320 Zener diode were installed as shown in figure 25. These limited the battery voltage to 20.5 volts and stopped the electrolyte bubbling. The supply performed without failure since that modification until 28 February 1975, when the system was shut down. Monthly checks found the batteries fully charged and not gassing. Water was added only once in November to the center group of batteries.

5.4.2.2 Solar Power at LP5 Sensor Site

A solar power system was installed at the LP5 sensor site on 22 October 1974, and was identical to that at the LP5 telemetry site, except that its solar converter array was furnished in two panels, Model LECA 30-0.9. The system operated without a failure through the remainder of the year.

Figure 27 shows a schematic of the LP5 solar power system for the sensor circuits, and figure 28 shows the structure which supported and housed components of the solar power system.

5.4.2.3 Solar Power at LP7 Telemetry Site

A solar power system was installed at the LP7 telemetry site on 14 November 1974, and was identical to that installed at the LP5 telemetry site, except that its solar converter array was furnished in three panels instead of one. The zener diode originally installed had too high a breakdown voltage and permitted the battery to overcharge and boil off water. A lower voltage diode was substituted to correct this condition. The system operated without failure and was shut down on 28 February 1975. Figure 29 shows the solar power system installed at the LP7 telemetry site. Figure 30 shows an interior view of the structure built to house and support components of the system.

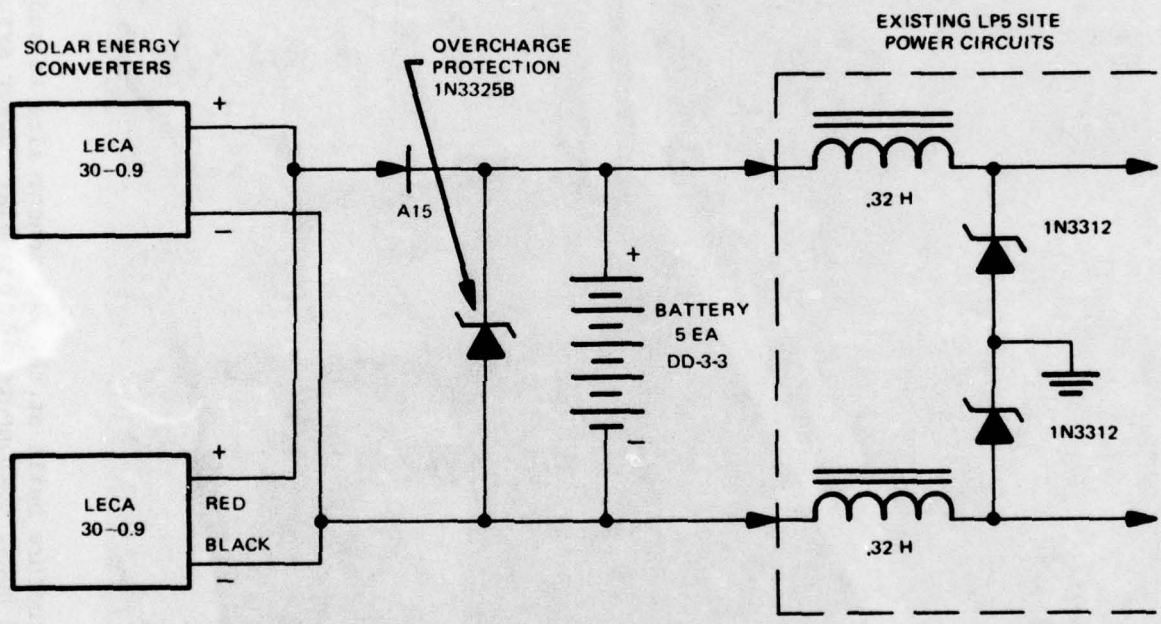

Figure 27. Solar power system for LP5 sensor circuits

G 7937



Figure 28. Structure built at the LP5 sensor site to support and house components of the solar power system

G 7938

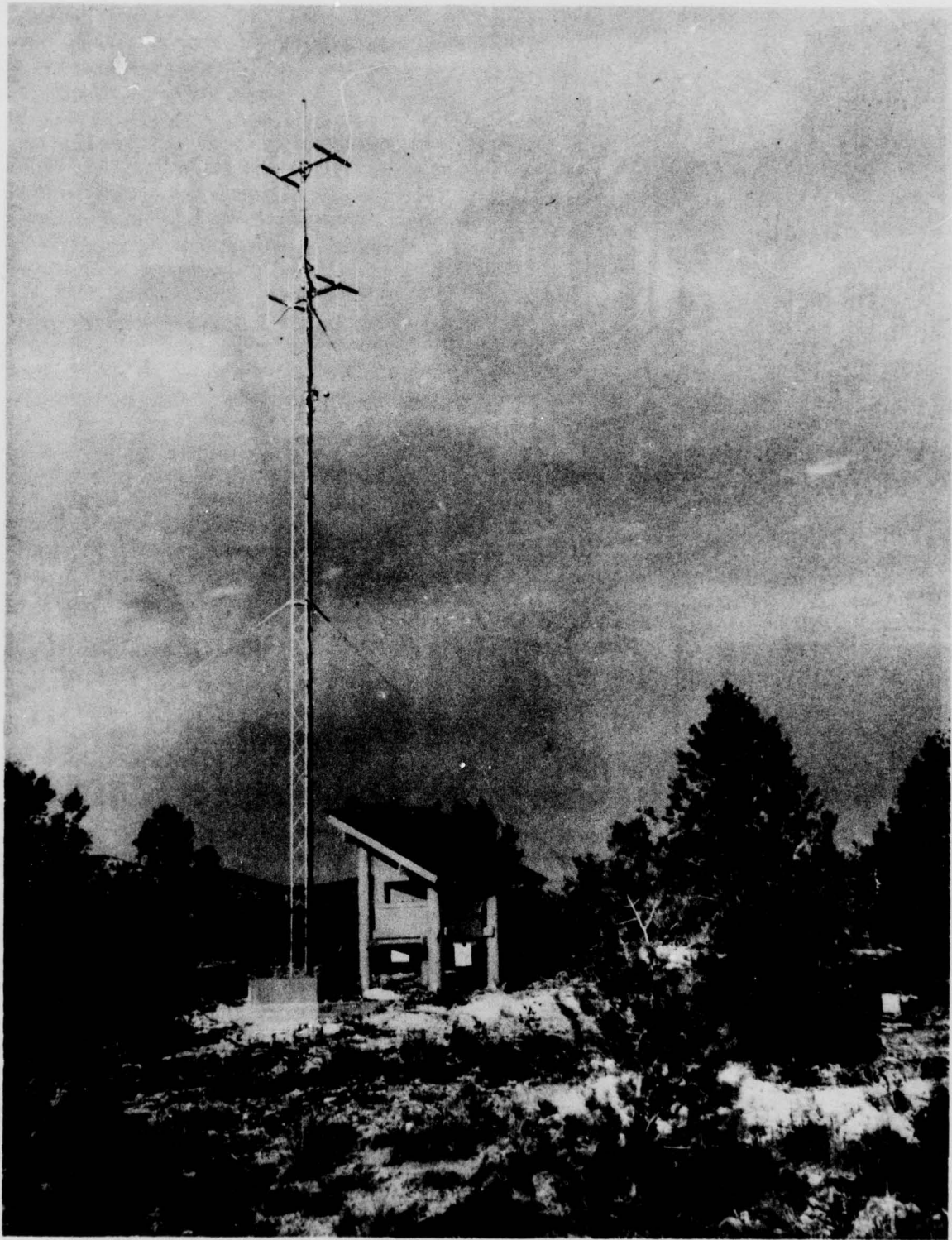

Figure 29. Solar power system installed at the LP7 telemetry site

G 7939

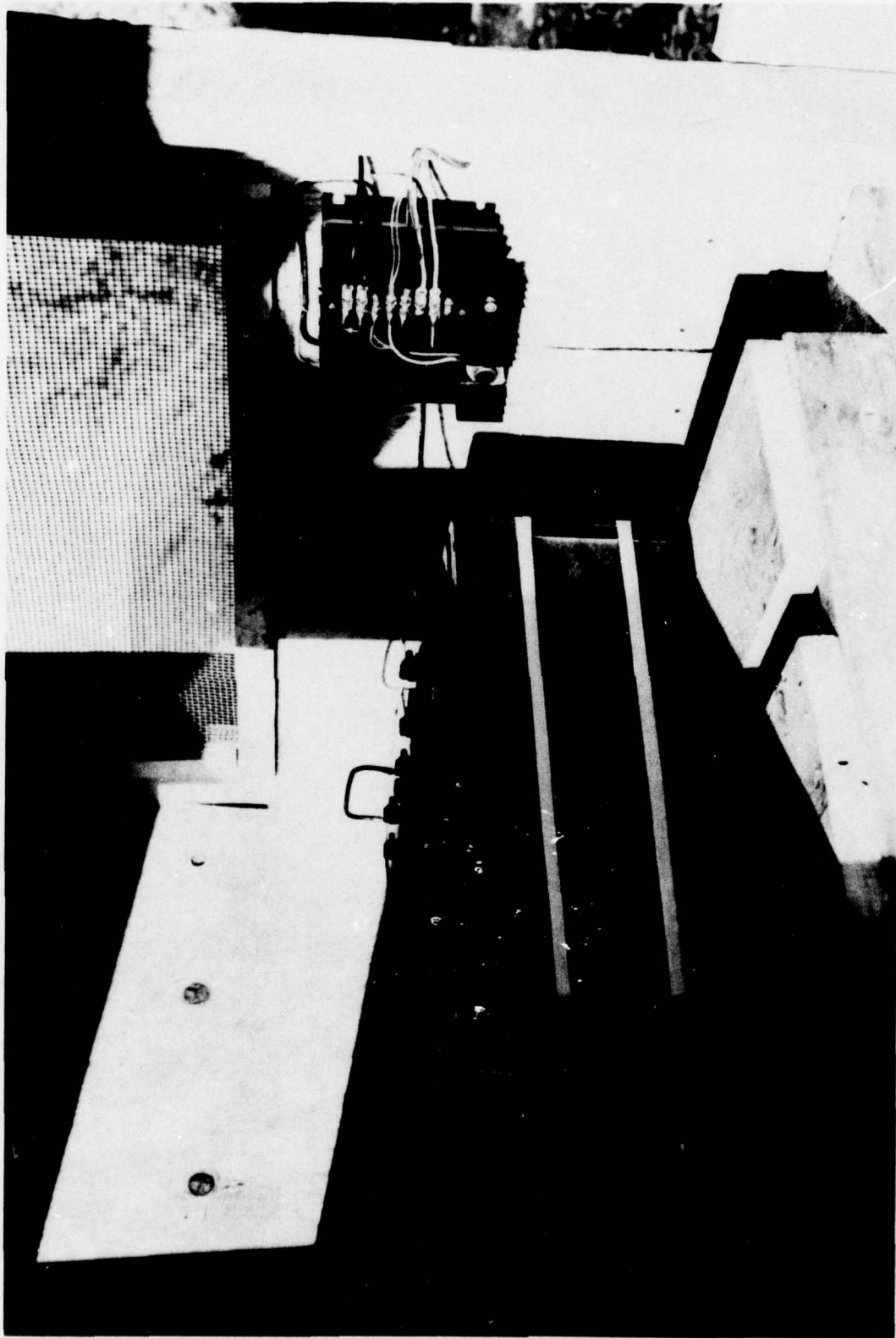

Figure 30. Interior view of the enclosure built to house and support components of the solar power system

G 7940

5.4.3 Wind Power

Technical data as well as price and delivery, information that was needed to determine the feasibility of powering remote seismograph and telemetry equipment with wind-driven generators was collected at TFO.

Wind velocities were measured from 16 April to 20 August 1974 at the LP7 telemetry site. The anemometer was located 30 feet above ground level. The daily wind velocity ranged from 2.5 to 9.2 mph. The maximum and minimum velocities for a 1-hour sample were 14 mph and 0, respectively. The overall average was 5.2 mph.

After reviewing the wind velocities and the wind patterns, it did not appear practical to continue the study.

5.5 OPERATION OF THERMOELECTRIC GENERATORS ON BUTANE-PROPANE MIXTURE

All thermoelectric generators (TEG's) used in Observatory field instrumentation systems have been fueled by propane because it will vaporize and maintain a usable pressure (20 psig) at ambient temperatures above -10°F , whereas butane will not vaporize and maintain a usable pressure unless the ambient temperature is 40°F or above. Because the scarcity of propane and the availability of butane in some areas of the world has promoted an interest in operating TEGs from an 80% butane/20% propane mixture, a program was undertaken at TFSO to evaluate the feasibility of such operation under TFSO field conditions. The test plan shown in appendix 3 was written; parts for one Thermoelectric Generator and Vaporizer Assembly, Model 34505, were fabricated; and 800 lbs of a butane-propane mixture were procured.

Early in March 1974, all materials were shipped to the TFSO where they were assembled and tested, then installed at the LP7 sensor site. The system was put into operation of 27 March 1974.

Figure 31 shows a photograph of the vaporizer assembly with its cover removed. Figure 32 shows the overall installation at LP7, sensor site with vaporizer mounted atop the TEG.

The system was operated from March 1974 through February 1975 with only minor outages and operational problems.

During December, a good temperature test was obtained when the air temperature dropped below zero on one day and fell below 10°F several other days.

Operational problems encountered and corrective actions taken are described in the following paragraphs.

Between 27 March and 11 April, the TEG burner flamed out several times. The automatic shutoff valve was closing because its sensing thermocouple was too tightly coupled to the heat source. This condition caused both the tip and body of the thermocouple to become heated and prevented the correct temperature differential from being established between these parts. Therefore, the valve shut off when the burner came up to its correct operating temperature. This

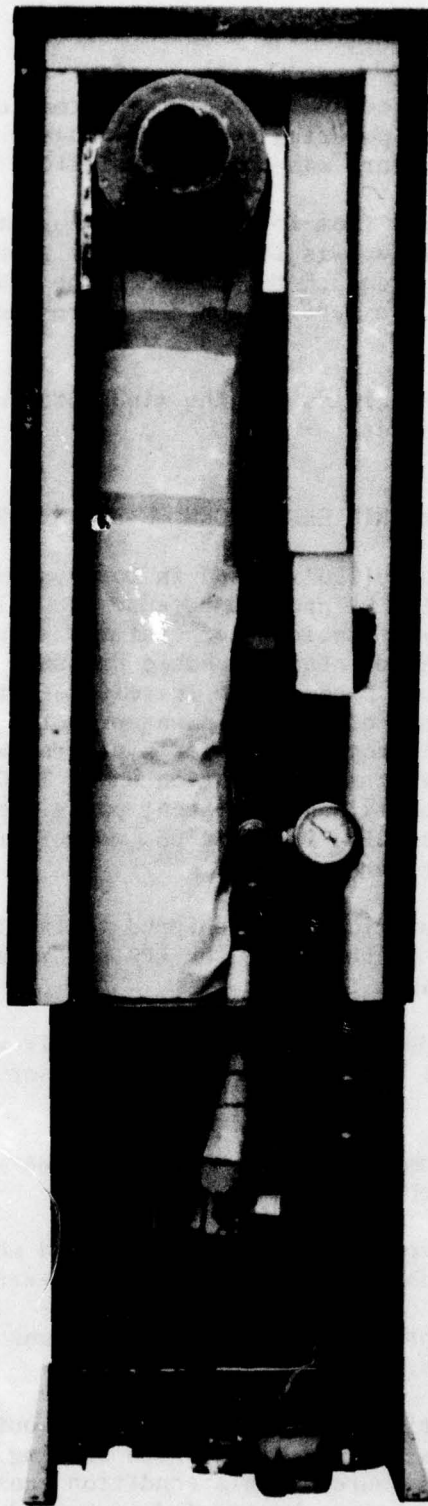

Figure 31. Vaporizer assembly with cover removed to show interior

G 7459

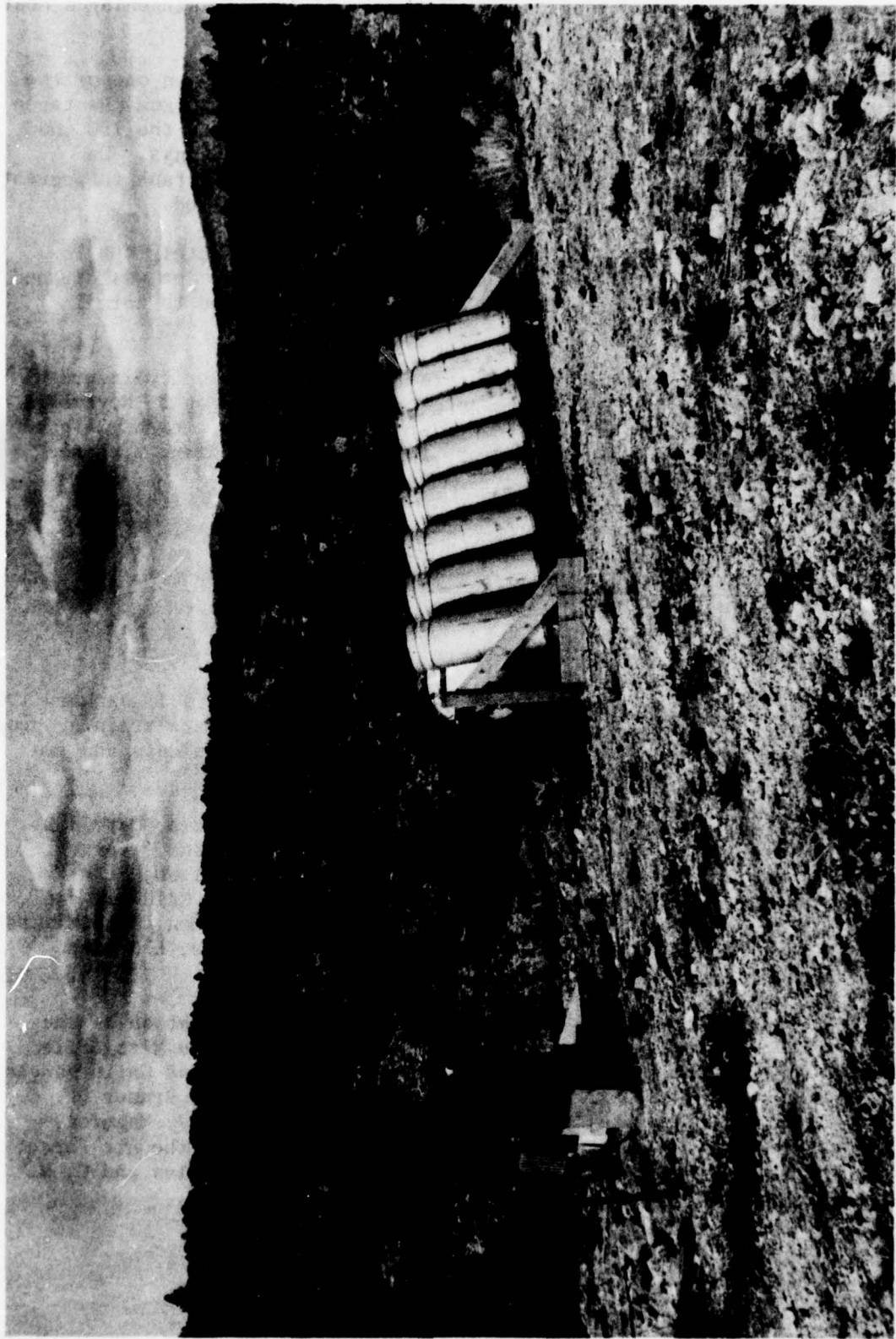

Figure 32. Thermoelectric Generator and Vaporizer Assembly, Model 34505, and butane/propane fuel tanks installed at LP7 site - TFSO

G 7460

condition was corrected by relocating the thermocouple and by attaching a heat sink to the thermocouple body.

On 4 May, the overpressure safety valve (pop-off valve) failed on one of the butane-propane tanks at LP7. This caused the loss of all fuel from the three 25-gallon tanks that were manifolded together to supply fuel to the TEG and vaporizer assembly. These tanks were replaced with two full tanks. On 28 May, a check valve was installed in the fuel line from each tank to prevent fuel loss from all manifolded tanks when one safety valve failed.

On 22 November, the TEG power output was found to be approximately 40% low. This was caused by a partially clogged burner jet. After the jet was cleaned, the TEG power output returned to normal, and the site returned to normal operation.

On 24 November, the TEG system ran out of fuel. Four 25-gallon cylinders of fuel, approximately 90 gallons, were connected to the system on 25 November, the TEG burner was ignited and normal operation was restored. Eight 25-gallon tanks were sent to Garland where they were filled with the butane-propane mixture and returned to the TFSO.

6. FACILITIES AND ASSISTANCE PROVIDED TO OTHER GROUPS

6.1 TEXAS INSTRUMENTS

The TI signal processor was at TFSO from 13 November 1973 until 17 January 1975, and during this time operational tests of the unit, as well as a training program on its operation, were conducted. TFSO made available station data and two Develocorders.

Personnel visiting TFSO in connection with the tests were Messrs. Harold D. Beck, Donald C. Douglass, Lonnie Pope, John Jubin, Harold Ingemi, George Herman, Jerry Kunkel, Tom McCullough, Charles Cooper, Bill Wilson, Stan Lenhart, J. Chris Vaughn, and Robert Frink of TI; Major L. R. Caldwell and Messrs. James Davern, Curtis Riggs, Ted Devorak, William Stephen, John Mazurek, Kenneth Lensing, Thomas Ertz, Richard Rubincam, James Rutledge, and Glenn Wright of the United States Air Force.

TI personnel conducted the 6-week training program on the operation of the processor from 8 July to 16 August 1974. The participants were Miss Effie Georgas and Messrs. J. R. Kunkle, K. C. Anderson, Bob Frink, and Chris Vaughn of TI; Messrs. E. P. Willison, C. J. Daigle, F. W. King, A. E. Brauer, P. C. Murphy, M. B. Horrell, Jr., R. E. Dalton, R. Evans, R. Feyen, J. Mazurek, C. Riggs, D. R. Kesselring, W. A. Stephan, and F. C. Bryan of the Air Force; Mr. D. G. Whitehead with O.M.S. of Canada; and Messrs. Phil Selva and C. M. McDonald of Teledyne Geotech.

6.2 SANDIA BASE

Mr. A. J. Smith, from the Sandia Base Military Reservation, delivered a specialized lightning protector to the TFSO for field test. The protector was wired into a 3-foot length of spiral-4 cable which was terminated in a standard hock at each end. It was installed during June 1974 in the Z18 spiral-4 cable at the first hock west of State Highway 87.

7. OBSERVATORY CLOSE-OUT

7.1 GENERAL

Verbal instructions were received to terminate the operation of TFSO at 2400Z on Friday, 28 February 1975.

Requests from the local news media for information concerning the closing were directed to the Project Office, and Dr. Carl F. Romney of ARPA gave a formal news release to the local paper, The Payson Roundup. A copy of the article from the paper is included in Appendix 4.

At the request of the Project Officer, the local Forest Service Ranger was notified of the close-up prior to the publication of the notice in the newspapers.

On 5 March 1975, a TWX was received from Joseph W. Gibbons, Contracting Officer, R&D, Patrick AFB, confirming the verbal instructions to stop routine operations. The TWX also requested that within 30 days an inventory of all technical equipment, including the operational condition of each item, be prepared, and that we dismantle and prepare for shipment all technical equipment of the observatory.

The TWX also stated that "No action should be taken by the Contractor for the close-out of Real Property, Spiral-4 Data cables on the ground, vaults, or roads."

As requested, we submitted the required information on the close-out in our TCP, P-2473, for Contract F08606-74-C-0007 on 13 March 1975. A copy of the TWX confirming the verbal instruction for the close-out is included as Appendix 5.

Our TCP, P-2473, is included as Appendix 6.

A target date of 30 June 1975 was set for completion of the close-out, but was not met due to some delays in obtaining distribution approvals for material items classed as "excess." However, representatives from the Plant Clearance Office, DCASD, Phoenix, were at TFSO and completed their reconciliation of the TFSO inventory by the end of September 1975.

It was originally planned to sell the estimated 1000 miles of spiral-4 cable used for data transmission at TFSO or give the cable to a responsible party for its retrieval and removal. When this plan did not materialize, Geotech

submitted an estimate to accomplish the task and was awarded the job. The U.S. Forest Service was awarded a contract to close roads, trails, and vaults used by the Observatory. The U. S. Forest Service was offered all Observatory buildings and associated facilities; however, the offer was not accepted because they could not justify their use. Eventually the buildings were assigned to the Gila County Highway Department.

7.2 DISPOSITION OF GOVERNMENT-FURNISHED PROPERTY

Retrieval of all field equipment was begun in March 1975 and completed during May 1975, with the exception of the radio antenna located at Diamond Point which was dismantled during June 1975. All property was stored either in the TFSO buildings or within the CRB compound. Figures 33, 34, and 35 show equipment being dismantled at the Observatory.

The Project Officer and the Station Manager visited the DCASD office in Phoenix on 28 April 1975 to coordinate the transfer of TFSO property. The DCASD personnel attending the meeting included Carl Whalen, Property Branch Supervisor; Skip Griener, Property Administrator; Ben Lucart, Plant Clearance Officer; and Charles Beck, Transportation Officer. Discussed during the meeting were the Contractor's responsibilities, transfer of property on DD Form 1149, residual property, and participation of DCASD in the overall property disposition.

After submitting a complete property inventory to the Project Office, a letter addressed to DCASR/DCRT/COM-26 T/Mr. Johnny A. White, ACO, furnished by the Project Office on 28 May 1975, listed the Observatory inventory and distribution lists for various agencies within the organization. Also, furnished was a listing of the excess Government property at the Observatory which had been screened by the originator of the letter. A further request stated that equipment transfers be expedited wherever possible so that the actions could be completed during FY 1975. A draft of this letter had been given to the Observatory earlier so sorting and preparation of the equipment for distribution could begin.

On 2 June 1975, prior to receipt of official notice of approval, we were advised to start shipment of about 1000 reels of unused spiral-4 cable to McClellan AFB. The cable was to have been sent by motor freight to Luke AFB in Phoenix, Arizona, and transshipped from there by air; however, the first truckload of 171 reels was rejected by Luke AFB and eventually all the cable was sent to McClellan AFB by motor freight.

Figures 36 and 37 show cable being loaded into trucks with fork lift.

A letter dated 4 June 1975 was received from the ACO granting approval for the physical transfer of property as requested in the letter of 28 May 1975. Packing instructions and GBLs for shipments were obtained from the Phoenix DCASD office. The shipping schedule follows:

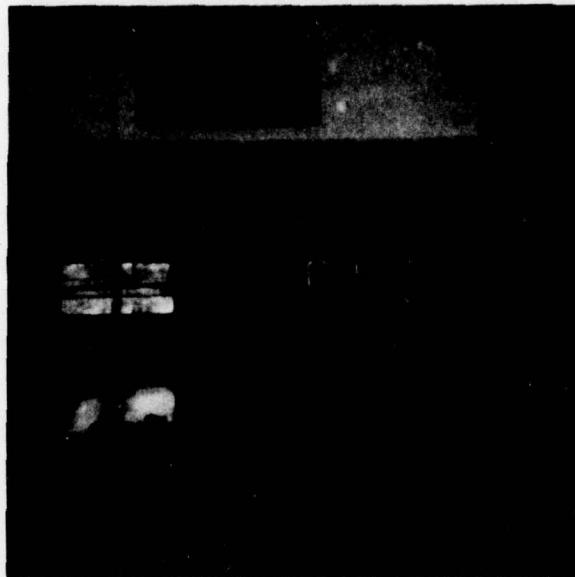

Figure 33. Dismantled data switching unit and cabling
from the subfloor at TFSO

G 9156



Figure 34. Dismantled calibration console at TFSO

G 9157

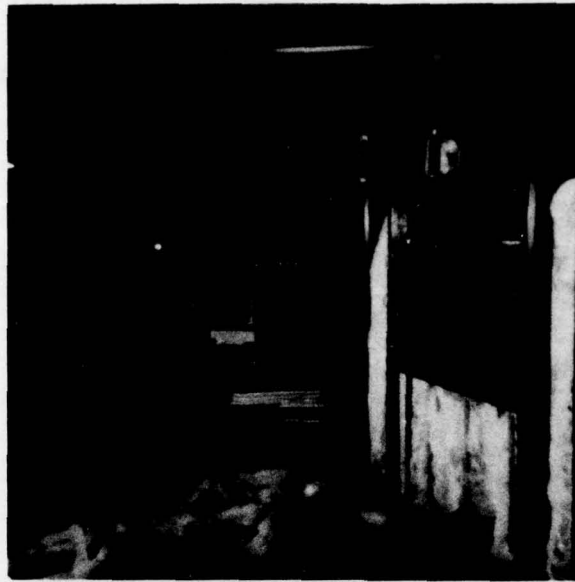

Figure 35. The TFSO data patch unit in process of dismantling

G 9158



Figure 36. Loading spiral-4 cable on pallet at TFSO
for shipment to 1155th

G 9159



Figure 37. Spiral-4 cable being loaded into truck
with fork lift at TFSO

G 9160

To McClellan AFB -

Shipped complete amplifiers, field power components and FM discriminator housings on 23 May by first-class mail.

Shipped 171 reels of spiral-4 cable on 3 June by motor freight.

Shipped 873 reels of spiral-4 cable on 27 June by motor freight.

Shipped remaining requested Government-Furnished Property by air-ride van on 28 June.

To SDCS, Garland, Texas -

Shipped the requested Government-Furnished Property on 26 June by motor freight.

Transferred the property already located in Garland, Texas on Form DD 1149 in June.

To SDAC, Alexandria, Virginia -

Shipped property by motor freight on 26 June.

To LASA, Billings, Montana -

Shipped property by motor freight on 26 June.

To Contract F08606-75-C-0021, Garland, Texas -

Shipped property by motor freight on 26 June.

USGS -

Picked up by USGS personnel 1 July.

Figures 38, 39 and 40 show the packaged shipments for USGS, 1155th, and SDCS, respectively.

The Government-Furnished Property remaining after the distribution assignments by the Project Office were fulfilled was considered residual or excess property. On 30 June 1975, DD 534 Forms listing the excess property were hand-carried to the Property Administrator in Phoenix, Arizona. When it became apparent that we would not receive approval to dispose of the excess items by the originally scheduled date, a letter requesting that the "Close out of TFO" be extended until the end of September was submitted to the AFETR/PMRA on 19 June 1975. The letter stated that funds already allocated in the contract were sufficient to accomplish the task.

The request for extension was granted.

On 24 July 1975, Carl Whalen, Chief, DCASD; Ben Lucart, Plant Clearance Officer; and R. K. Greiner, Property Administrator, DCASD, were at TFSO and provided useful information and help in preparing the remainder of the inventory for disposal. DCASD, Phoenix, was urged to provide us approved distribution lists in time for us to meet the new schedule of 30 September 1975.

On 6 and 7 August, Mr. Ben Lucart, Plant Clearance Officer, DCASD, Phoenix, Arizona, assisted by H. E. Lashlee, GSA, Tucson, Arizona, was at TFSO to supervise the selection and tagging of the remaining excess Government property by 16 personnel from the following agencies.

- University of Utah,
- USGS, Flagstaff, Arizona,
- USGS, Menlo Park, California,
- University of Arizona, Tucson, Arizona,
- Interstate Commerce Commission, San Francisco, California,
- Interstate Commerce Commission, Phoenix, Arizona,
- State of Arizona (State Surplus), Phoenix, Arizona,
- Concho School District, Concho, Arizona,
- DCASD, Phoenix, Arizona.

The Arizona State Surplus people were last on the list to select and tag property and they tagged all items not taken by the other agencies.

Figure 41 shows test equipment and other property after tagging by various agencies. Figure 42 shows the LP5, Chalk Mountain Witte generator shack during dismantling.

Mr. Dennis Dillinger and Mrs. Kate Smith, DCASD, Phoenix, visited the Observatory on 2 September to coordinate carting and shipping of three DIPEC items from the shop.

Mr. Ben Lucart, Plant Clearance Office, DCASD, Phoenix, was at TFSO 24 through 27 September. Reconciliation of the inventory was made and instructions were given regarding finalizing the property.

On 20 September 1975, the complete TFSO inventory of instrumentation and materials had been officially transferred. All items were removed from the

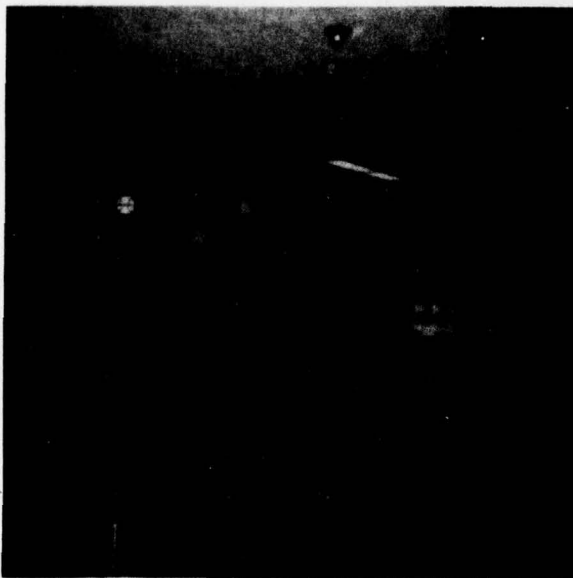

Figure 38. Packaged items to be shipped to USGS,
Albuquerque, New Mexico

G 9161

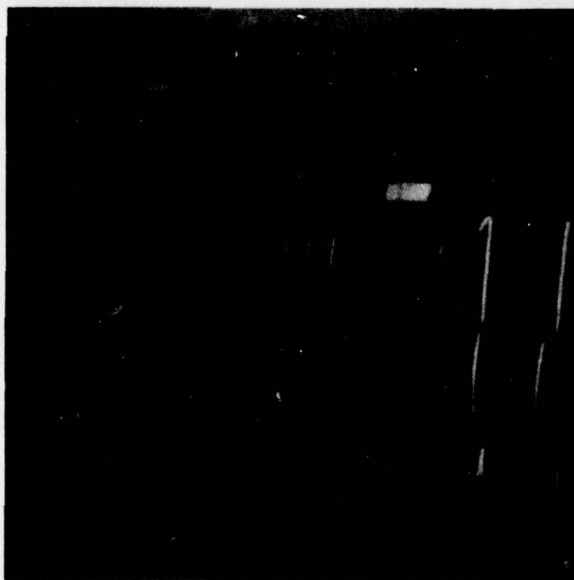

Figure 39. Packaged items to be shipped to 1155th,
McClellan AFB

G 9162

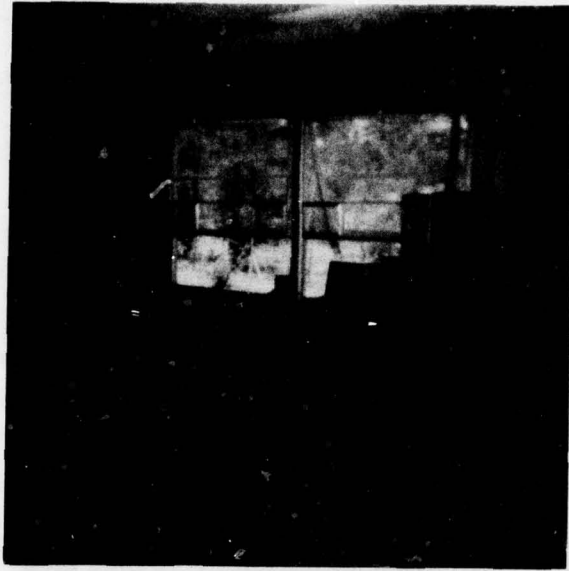

Figure 40. Packaged items to be shipped to Project VT/4703,
SDCS, Garland, Texas

G 9163

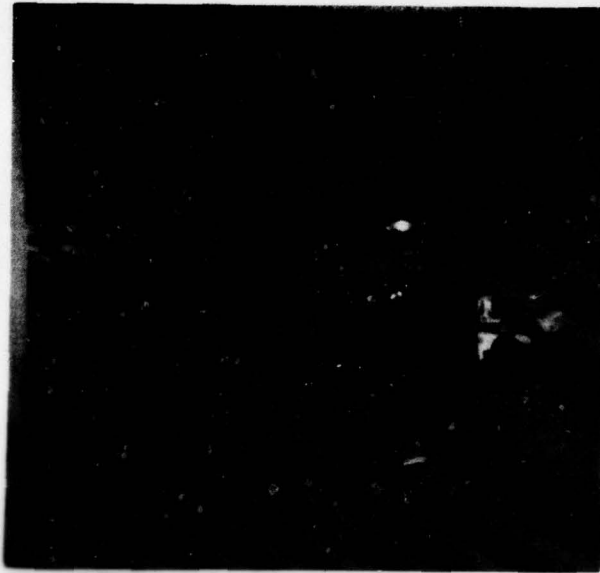

Figure 41. A portion of TFSO test equipment and other
property after tagging by various agencies

G 9164

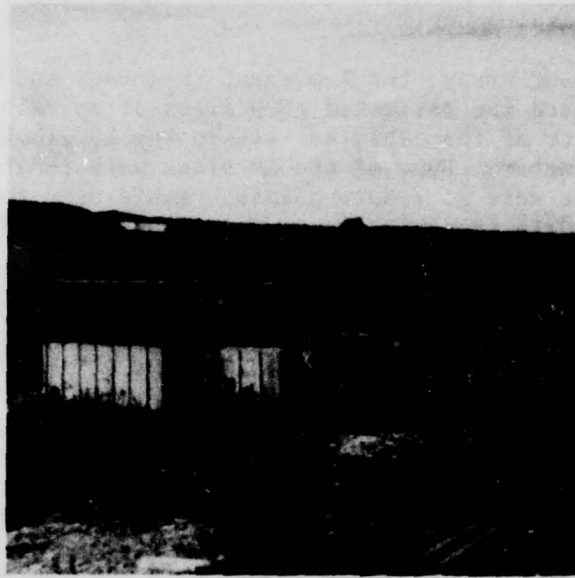

Figure 42. The LP5 Chalk Mountain Generator Shack being dismantled

G 9165

facility except for a Witte generator and three shop items. The Witte generator was sold on site to the high bidder and removed from Chalk Mountain area. The three crated DIPEC shop items were shipped motor freight on a GBL.

7.3 RETRIEVAL AND DISPOSAL OF SPIRAL-4 CABLE AND JUNCTION BOXES

7.3.1 General

Geotech's proposal for the retrieval and disposal of an estimated 1000 miles of spiral-4 cable and approximately 600 junction boxes from the SP and LP arrays was approved and work commenced on 14 October 1975. Our plan was to reel the cable onto metal spools where feasible and to either drag or haul the remaining cables by truck to burial pits to be buried along with the reeled cable. Three burial sites were approved by Payson District Ranger, Hugh Thompson, with the U. S. Forest Service.

However, at the request of Mr. Tom Brock, Real Estate Office, Corps of Engineers, Phoenix, Arizona, excavation of burial sites was postponed due to the materials having possible salvage value. Prospective buyers were located by Mr. Brock and it was decided to reel all the spiral-4 cable where possible and to discontinue the plan to bury the cable. Retrieval of the spiral-4 cable and junction boxes was completed during February 1976.

7.3.2 Retrieval of Spiral-4 Cable

Cable from the 19-element array, the 7-element LP array, and the radio tower on Diamond Point constituted the estimated 1000 miles of spiral-4 cable to be retrieved. The majority of the cable was within the 19-element array which was about 20 km in diameter. Four of the LP sites were located inside the 19-element array; three were at remote points. Cable used for power and telephone hookups and data transmission to relay towers was the only cable remaining at the three remote LP sites.

Nine hundred thirty-four miles of spiral-4 cable were reeled on 2,492 metal spools and stored at an inconspicuous site near the CRB. Figure 43 shows some of the stored spiral-4 cable.

It was impossible to reel the cable in the normal continuous quarter mile lengths due to cable being entangled in brush and dirt. Cables were cut and dragged by vehicles into cleared areas where they were reeled onto the metal spools. Figure 44 exhibits cable tied to vehicle for dragging to a cleared area and figure 45 shows cable being reeled on spools by power reeler. Cable segment lengths depended upon the amount of entanglement involved in various areas. Also, because of a shortage of metal spools, approximately three-eighths of a mile of cable was reeled onto each spool rather than the normal quarter mile. There was a surplus of sixty metal spools as shown in figure 46 at the completion of the job.

To expedite cable pickup, hocks were cut from the cable prior to reeling. Approximately 1000 hocks were recovered for salvage purposes. Figure 47 shows the hocks located at the storage area.

In addition to the reeled spiral-4 cable, approximately 60 miles of unreeled cable was hauled from the field to the storage area. This cable was so tangled that it was not practical to attempt reeling it. Most of the entangled cable was due to slack left at each junction box during initial installation. Figure 48 shows approximately one-half of the retrieved unreeled cable. Quantities of cables and hocks retrieved are listed in table 11.

In addition to the spiral-4 cable, approximately 7 miles of multiconductor cable was retrieved. Since spools with capacity to reel cable onto were not available, the cables were cut, coiled, and hauled by truck to the storage area. Figure 49 shows the coiled multiconductor cable.

7.3.3 Retrieval of Junction Boxes

Approximately 600 assorted sizes of junction boxes were retrieved from the field installations. The junction boxes located along multiple cable trails were mounted on wooden cross members attached to wooden poles and included a ground rod. The junction boxes installed along single cable trains were mounted on metal fence poles. Figure 50 shows a typical junction box installation along a multiple cable trail.

The junction boxes were dismantled by sawing the cross members and pulling the wooden poles and the metal pole installations were dismantled by unbolting the



Figure 43. Partial lot of reeled spiral-4 cable
retrieved from the TFSO arrays

G 9166



Figure 44. Spiral-4 cable attached to truck prior to dragging
to cleared area from brush entanglement

G 9167



Figure 45. Spiral-4 cable being reeled onto metal spools using a power reeler

G 9168



Figure 46. Empty surplus metal spools

G 9169

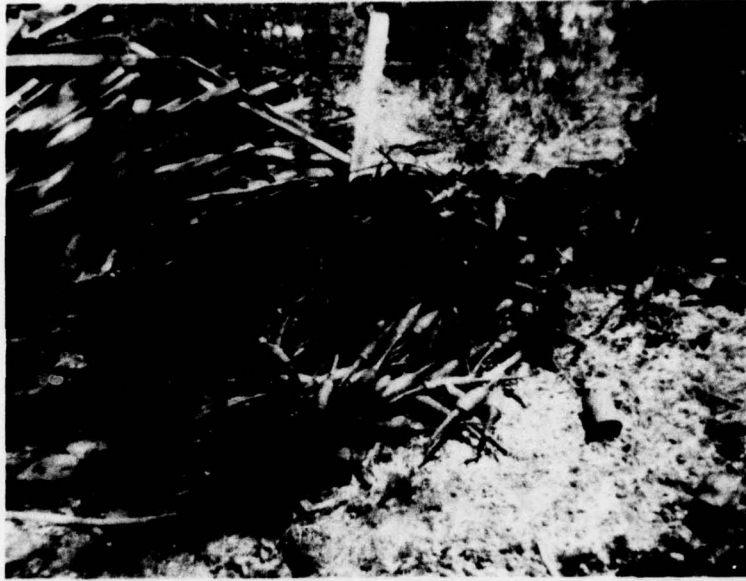

Figure 47. Spiral-4 cable hocks

G 9170



Figure 48. Approximately 30 miles of unreeled spiral-4 cable
retrieved from within the TFSO arrays

G 9171



Figure 49. Approximately 7 miles of multiconductor cable coiled in various lengths

G 9172



Figure 50. A typical multiple cable trail junction box installation

G 9173

Table 11. Summary of the disposition of retrieved salvageable materials at TFSO

<u>Assignee</u>	<u>Materials List</u>	<u>Date of Transfer</u>
White River Apache Tribe	25 reels spiral-4 cable (approx 9 mi)	29 March 1976
University of Arizona	80 reels spiral-4 cable (approx 30 mi)	29 April 1976
New Mexico Institute of Mining and Engineering	40 reels spiral-4 cable (approx 15 mi) approx 1000 brass hooks approx 60 copper coated ground rods approx 30 fence poles approx 60 metal spools	5 May 1976
Gila County, Arizona	20 reels spiral-4 cable (approx 7.5 mi)	7 May 1976
Northern Arizona University	40 reels spiral-4 cable (approx 15 mi)	13 May 1976
White Mountain Apache Enterprise	20 reels spiral-4 cable (approx 7.5 mi)	19 May 1976
Smashmobile George W. Power	2,267 reels spiral-4 cable (approx 850 mi) Unspooled spiral-4 cable (approx 60 mi) Coiled multi-cond. cable (approx 7 mi) Assorted size J and H boxes (about 500)	18 May - 3 June 1976

the junction boxes and then the poles were pulled from the ground. Figure 51 shows the junction boxes located at the storage area. Figure 52 shows the wooden material used in the junction box installations and figure 53 shows the metal fence poles and ground rods.

7.3.4 Disposal of Materials

At the request of the Corps of Engineers, the Phoenix DCASD office assumed the responsibility for disposition of the salvageable property. DD Form 543, listing the property items, along with photographs of each item, were submitted to the Corps of Engineers in February 1976. The Corps of Engineers then forwarded the Form 543 to the Phoenix, Arizona, DCASD office with their request for DCASD to process the disposition of the salvageable property. Notice of acceptance of inventory, DD Form 1637, was received from the DCASD Plant Clearance Officer, Mr. Ben Lucart, on 24 March 1976.

The DCASD office circulated the list of property to various agencies prior to offering the property for sale. Mr. Arch Penrod, Department of Commerce,

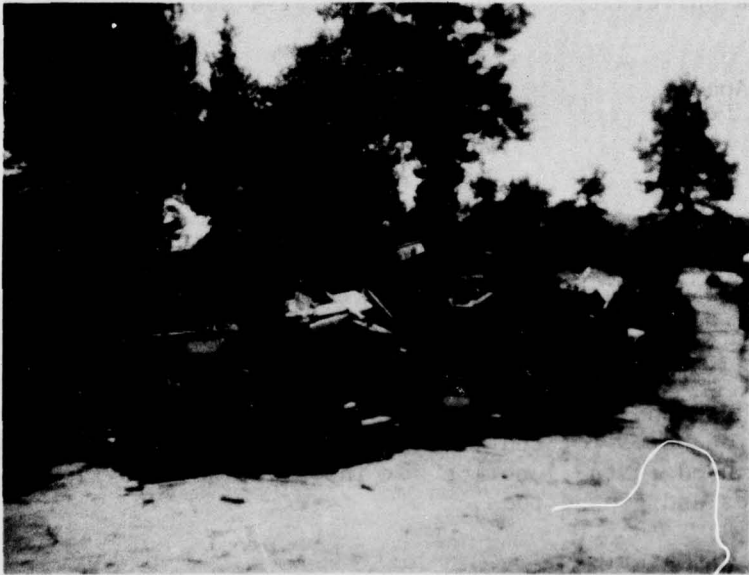

Figure 51. Approximately 600 assorted sizes junction boxes retrieved from within the TFSO arrays

G 9174

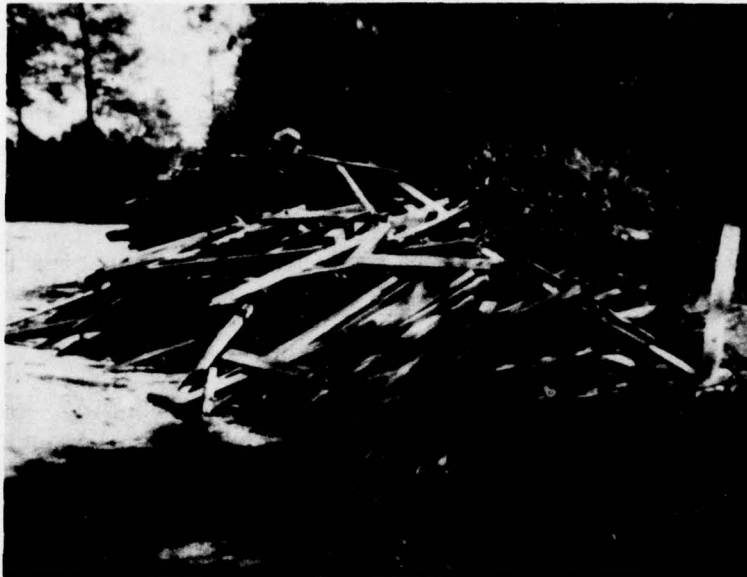

Figure 52. Wooden materials used in junction box installations along the multiple cable trails

G 9175

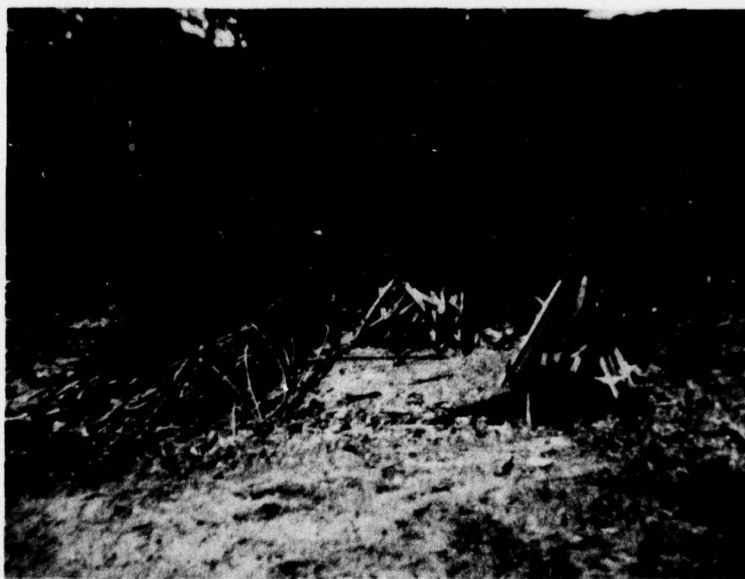

Figure 53. Ground rods used in junction box installations along the multiple cable trails and fence poles used in the installations along the single cable trails

G 9176

Four Corners Regional Commission, Albuquerque, New Mexico, requested through the DCASD office various amounts of reeled spiral-4 cable and other items for several agencies.

Notice to solicit bids on the TFSO salvage items was received from the DSA Plant Clearance Officer, Mr. Ben Lucart, on 20 April. Included with the notice was a list of 15 prospective bidders and an abstract for keeping record of bidder's response. Procedures to solicit bids were coordinated with Mr. Lucart and the invitation to bid forms were sent to prospective bidders on 30 April. To assure that all the prospective buyers had received notice of the sale, each was contacted by phone on 5 May 1976. We were unable to contact one prospect who was apparently out of the country.

Four sealed bids were received by 14 May, the date of opening, and Mr. B. R. Lucart was in Payson for the opening. The high bid in the amount of \$5,736.84 was submitted by George W. Power, Smashmobile, 6201 S. 123rd Street, Tolleson, Arizona 85353. Mr. Lucart declared Mr. Power the successful bidder.

As requested, Mr. Power presented the station manager a cashier's check for the amount of sale payable to DCASR, Dallas, Texas. The check was sent to Mr. Lucart in Phoenix via certified mail for transmittal to DCASR, Dallas, where credit for the sale amount would be given Contract F08606-74-C-0007. Mr. Power removed all the materials he purchased by 3 June 1976.

Table 11 shows the disposition of all salvageable materials retrieved.

7.4 REAL PROPERTY

7.4.1 General

On 1 May 1975, a meeting was held at TFSO to review the status of Real Property at the Observatory and plan for its closeout. Attending the meeting were Thomas Brock, Corps of Engineers; Thomas Muir, Real Property Officer; Major Edward Moore III, USAF, Civil Engineer, Patrick AFB; Lt. Michael J. Shore, Project Officer, VELA; Robert Tippiconnic, Forest Ranger and Charles J. Brandt, Assistant Forest Ranger, U.S. Forest Service, Payson District; B. B. Leichliter, Program Manager, Geotech; and Gayle Stanfill, Observatory Manager, TFSO.

Mr. Brock explained the major items of real property and presented a plan to the Forest Service, which he hoped would be acceptable to all parties. Under this arrangement, all buildings and facilities would be transferred to the Forest Service for their use, including the spiral-4 cable on the ground, the two walk-in-type vaults, the tank-type vaults, and the cable trails which the Observatory was responsible for closing. The Real Property Officer stated he was prepared to sign the transfer papers on the spot if the Forest Service were agreeable. The Forest Service representative said he would like time to conduct feasibility studies and to coordinate with his superiors. The Ranger did say that if the Forest Service decided not to accept the building and facilities they would have to be removed. Mr. Brock commented that the buildings could readily be sold and would compensate to a large degree for removal of cable and closing of trails.

When the Ranger was asked for an estimate of rehabilitation costs for the area, he said an on-site inventory requiring approximately 20 mandays by one of their experienced engineers would be necessary. Mr. Brock agreed to provide funds to conduct this survey if the Ranger would request the funds in a letter to the Corps of Engineers.

During this meeting, the Project Officer approved a request by the Forest Service to use the LPI site for a heliport.

7.4.2 Spiral-4 Cable and Other Field Materials

The spiral-4 cable, junction boxes and other related field materials were transferred back from the Real Property to Government-Furnished Property.

7.4.3 Transfer of LPI Site to the U. S. Forest Service

As approved by the Project Officer, the U. S. Forest Service constructed a heliport adjacent to the LPI compound during May 1975. Field offices were moved within the LPI compound and obstacle courses were constructed for fire fighting training purposes. In addition, the earth was excavated from the north side of the walk-in vault and an entranceway was installed. The vault was then used for classrooms and for storage area.

The Forest Service used the area from May through September 1975 when the installation was disbanded for a more advantageous location near the Forest Service Ranger Station.

7.4.4 Rehabilitation of Cable Trails, Access Roads, and Field Installations

As requested by Mr. Tom Brock during the May meeting, the Forest Service submitted to his office in August 1975 a preliminary cost estimate report for the rehabilitation of the TFSO cable trails, access roads, and field installations. The report was forwarded to the TFSO station manager by the Corps of Engineers for evaluation. The review revealed that only about 40 percent of the cable trails referenced in the report were actually constructed by the Observatory, and the remainder had been in existence prior to the Observatory installation. Maps of cable trails were color-coded to give a visual presentation of the comparison between the two interpretations and copies were supplied to the Project Officer and to Mr. Tom Brock. Based on the evaluation, the original cost estimate of about \$74,000 was reduced to about \$47,000.

The Forest Service began the rehabilitation work in June 1976.

7.4.5 Disposition of Buildings, Facility Equipment, and Miscellaneous Items

Mr. Tom Brock, U. S. Army Corps of Engineers called a meeting on 9 February 1976 at the TFSO. Attending were Thomas Muir, Real Property Officer, Williams AFB, Arizona; Major Edward S. Moore, II, AFTAC/LGD; Michael J. Shore, Project Officer, AFTAC/VSC; Ranger Hugh C. Thompson, U. S. Forest Service, Payson District; John P. Haynes, Engineer, Tonto National Forest; B. B. Lechliter, Program Manager; and Gayle M. Stanfill, Teledyne Geotech.

The purpose of the meeting was to coordinate the final phase-out of the TFSO. The Forest Service agreed to submit a cost proposal to Mr. Brock for rehabilitation of short-period and long-period vaults; removal of asphalt roads, culverts, guard rails, wells, walk-in vaults; resotation of the CRB-complex area; and removal of the TFSO-owned power lines. Also to be incorporated into the proposal was the previously submitted cost estimate for rehabilitation of the access roads and cable trails.

The cost proposal, along with a description of the work to be accomplished, was furnished Mr. Brock on 25 February 1975. The proposal was evaluated by Geotech and returned with only minor corrections by 9 March 1975. The Forest Service estimate was itemized in such a manner that should the buildings be given to someone on-site, the close-out costs could be adjusted accordingly.

Several school districts were interested in obtaining the buildings and Gila County wanted the buildings on-site for county vehicle maintenance and storage yard. The Forest Service at first refused to permit the building to remain on the Forest Service land, and according to the original letter of understanding, the Air Force was responsible for their removal. However, during April, Mr. Brock advised us that the buildings would be given to Gila County and that the County had made a land trade with the Forest Service that would permit the buildings to remain on-site.

On 22 April 1975, the Real Property inventory was checked with Mr. Carmen Corso, a Gila County representative. All items were found to be in order.

Routine checks of the Observatory buildings and grounds were conducted until 14 June. Mr. Brock was contacted on 8 June 1976 to coordinate the transfer of the TFSO facilities. Mr. Brock stated that there had been no final action taken to transfer the buildings and requested that the facilities keys be left with the Payson Forest Service Ranger. Gate and building keys were given to Ranger Hugh Thompson on 11 June 1976. At that time Ranger Thompson said that the transfer of buildings had not been made.

APPENDIX 1 to TECHNICAL REPORT NO. 76-7

STATEMENT OF WORK

AD-A035 339

TELEDYNE GEOTECH GARLAND TEX
OPERATION OF THE TONTO FORES SEISMOLOGICAL OBSERVATORY. (U)
AUG 76

F/G 17/10

UNCLASSIFIED

TR-76-7

F08606-74-C-0007

NL

2 OF 2

AD
A035339



END

DATE
FILMED
3-77

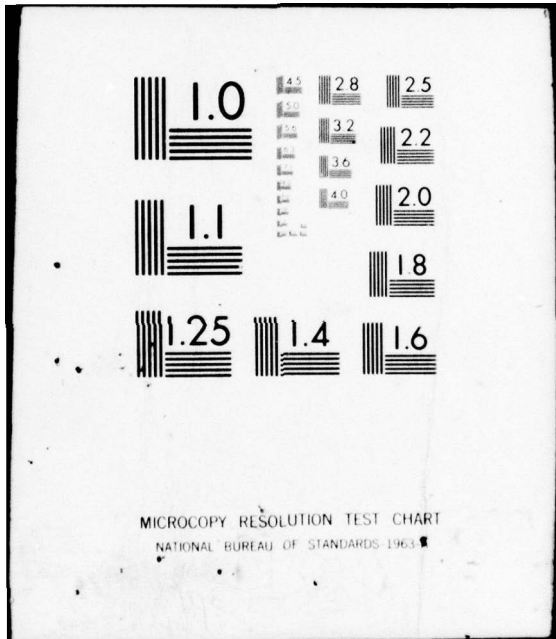

MICROCOPY RESOLUTION TEST CHART
NATIONAL BUREAU OF STANDARDS-1963-A

6 Feb 73

STATEMENT OF WORK TO BE DONE
(AFTAC Project Authorization No. VELA T/4704/B/ETR)

1.0 Objectives: The work called for under this project is being undertaken in response to the Defense Advanced Research Projects Agency's (ARPA) objective of improving the nation's capability in the detection and identification of underground nuclear explosions. This program includes investigation of state-of-the-art hardware, systems, and data reduction techniques utilizing various seismic detection system configurations. Because the Tonto Forest Seismological Observatory (TFSO) possesses a unique low level of background seismic noise and is well equipped as a research center, being equipped with various film, paper, and analog and digital recorders, a shake table, a large walk-in vault for instrument evaluation, and assorted test and measurement equipment, the TFSO provides a valuable contribution to the ARPA objectives.

2.0 Scope: This project will have a 12-month duration. The purpose of this project is to operate this observatory as a source of high-quality seismological data for use in government-sponsored research projects, to use the TFSO as a field test site for evaluation of new seismological instrumentation and procedures, and to support other research projects as directed by the project officer. This project should require a total manning level of approximately 5 man-years.

3.0 General Background: This project is part of a continuing effort in which the TFSO was constructed in 1963 under Project VT/070 and is presently operating under Project VT/3704. Data from this array are presently being provided to the scientific community through the Seismic Data Laboratory and Seismic Array Analysis Center, and are being used in evaluation of the ARPA large arrays, LASA, ALPA, and NORSAR. Additionally, results of hardware and system tests at TFSO are provided to the seismological community and have been incorporated into various modifications in both civilian and government systems.

4.0 Tasks:

4.1 Operation:

4.1.1 The contractor will continue operating the TFSO according to established procedures (Standard Operating Procedures for TFSO, 1 Nov 70), providing standard recorded data to the government.

4.1.2 The contractor will quality control the data acquisition systems and evaluate the seismic data recorded to determine optimum operating characteristics and perform research to improve operating parameters to provide the most effective observatory practicable. Major reconfigurations in equipment, those requiring more than 48 hours to remove, are subject to prior approval by the project officer.

4.1.3 The contractor will provide use of observatory facilities and seismological data to requesting organizations and individuals as identified by the project officer.

4.1.4 The contractor will maintain, repair, protect, and preserve the facilities of TFSO in good physical condition in accordance with sound industrial practice.

4.2 Research:

4.2.1 The contractor will evaluate the performance characteristics of experimental equipment identified by the project officer. This work includes investigation of the operational capability of dry film recorders and station processors with real time full duplex data transmission between TFSO and Patrick AFB, Florida. Additional investigations will be initiated by the contractor as problems requiring investigation are identified.

4.2.2 It is anticipated that periodic recording of special data will be required. These special data requirements will be identified by the project officer and will include, but not be limited to, recording signals from special events at the Nevada Test Site, and supplying beamformed or multichannel filtered data for use in evaluation of the effectiveness of the ARPA long-period arrays.

4.2.3 The total level of effort on the research task will not exceed one man year.

4.3 Upon identification and prior to the disposition of any equipment determined to be excess to the needs of the project the contractor shall notify the project officer.

5.0 Data: The contractor shall assure that technical reports, manuals, handbooks, drawings, specifications, or other data required by this contract are prepared and delivered in accordance with contractual requirements. This includes assuring conformance to requirements for style, format, legibility, technical coverage, content, accuracy, adequacy, and delivery.

REPRODUCTION

APPENDIX 2 to TECHNICAL REPORT NO. 76-7

ADMINISTRATIVE TERMINATION OF
TFSO FACILITY SECURITY CLEARANCE

TELETYPE
GEOTECH

3401 SHILOH ROAD

GARLAND, TEXAS 75040

(214) 271-2561 TELEEX 732394

MAIL P.O. BOX 28277, DALLAS 75226

25 March 1975

Defense Contract Administrative Service,
Region; Los Angeles
Office of Industrial Security
Phoenix Field Office
3800 North Central Ave.
Phoenix, Arizona 85012

Attention: Mr. Kenneth G. Ozbolt

Reference: Facility Clearance
Tonto Forest Seismological Observatory
Payson, Arizona (2 Miles Northeast)

Dear Mr. Ozbolt:

Confirming telephone discussions of 17 March and 24 March as regards
the the REFERENCE, Facility Clearance.

As the result of closed contracts and the discontinued operation of
the REFERENCE Facility, please accept this correspondence as authority
to administratively terminate the REFERENCE Facility Clearance, without
prejudice.

Futher, the following conditions exist and actions are in process:

- a. All observatory operations were discontinued 28 Feb 1975
- b. There is no CLASSIFIED Material to be disposed of
- c. The employees clearances will be transferred to the facility at:
3401 Shiloh Road
Garland, Texas 75041

We appreciate your cooperation in the matter, the manner in which you
have serviced this facility for the past several years, and hope we may
have the opportunity to work with your office again.

Respectfully,

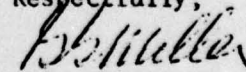

G. G. Miller
Security Officer

cc: DCASR, Dallas, attn: R.A. Massey
Teledyne Inc: Mr. J.C. Stewart
TFSO: Mr. G.M. Stanfill
M.G. Gudzin
G.C. Skipworth
E. Stephens

GGM/am *L. S. H. K. - 6 11-76*



DEFENSE SUPPLY AGENCY
DEFENSE CONTRACT ADMINISTRATION SERVICES REGION, LOS ANGELES
OFFICE OF INDUSTRIAL SECURITY PHOENIX FIELD OFFICE
3800 NORTH CENTRAL AVENUE
PHOENIX, ARIZONA 85012

9 April 1975

IN REPLY
REFER TO

DCRL-10X

Mr. Gayle M. Stanfill, Manager
Telcdyne Industries, Inc.
Geotech Division
P. O. Box F
Payson, AZ 85541

Dear Mr. Stanfill:

An industrial security inspection was conducted at your facility on 17 March 1975, by the undersigned.

Inasmuch as we received your written request for administrative termination of your facility security clearance, a final security inspection was conducted. This letter acknowledges receipt of your Letter of Notification of Facility Security Clearance, DSA Form 381-R. During the inspection, it was found your facility has met all requirements of the Department of Defense Security Agreement.

I would like to express my appreciation for the manner in which you have conducted your Security Program during our association. It is our hope that, in the future we can be of assistance to you, your staff or Geotech.

Notification of the termination of your facility clearance will be forthcoming from the Region headquarters.

Sincerely,

KENNETH G. OZBOLT
Industrial Security
Representative-in-Charge



DEFENSE SUPPLY AGENCY
DEFENSE CONTRACT ADMINISTRATION SERVICES REGION, LOS ANGELES
11099 SOUTH LA CIENEGA BOULEVARD
LOS ANGELES, CALIFORNIA 90045

APR 28 1975

62927

IN REPLY
REFER TO

DCRL-IF (D. O. KUHN/643-0178/di)

24 April 1975

Teledyne Industries, Inc.
Geotech Division
ATTN: Security Officer
P. O. Box F
Payson, AZ 85541

Gentlemen:

Please be advised that this office has today administratively terminated the facility clearance granted 9 February 1966 in accordance with your request.

This action is the result of your letter dated 25 March 1975 requesting termination of your facility security clearance.

Please be assured that this action in no way reflects upon your past ability to safeguard classified information, and your facility security clearance may be reprocessed when the occasion and need arise for you to perform on classified work.

Sincerely,

B. W. TANNER
Chief, Facilities Division
Office of Industrial Security

Handwritten notes:
B. W. Tanner
B. W. Tanner

APPENDIX 3 to TECHNICAL REPORT NO. 76-7

TEST PLAN
OPERATION OF THERMOELECTRIC GENERATOR
ON BUTANE-PROPANE MIXTURE

7 March 1974
M.G. Gudzin

TEST PLAN
OPERATION OF THERMOELECTRIC GENERATOR
ON BUTANE-PROPANE MIXTURE

1. PURPOSE

In some world areas, propane is expected to become scarce, while butane is expected to become more plentiful. Thermoelectric generators (TEG's), used in these areas, will be forced to operate on a mixture of 80% butane and 20% propane. Work under this test plan will be carried out to determine the feasibility of operating a conventional TEG on such a mixture.

2. DESCRIPTION OF EQUIPMENT

The typical TEG's we use will operate equally as well on butane or propane provided that the fuel is fed to the TEG in a gaseous or vapor state, not a liquid state. This normally is no problem when propane is used because propane boils (changes from a liquid to a gas) at -44°F at normal atmospheric pressure and boils at -30°F at 8 psi, the normal pressure inside a TEG. Butane, however, boils at $+32^{\circ}\text{F}$ under normal atmospheric pressure and boils at $+53^{\circ}\text{F}$ at 8 psi. Therefore, during most of the year at many field sites, butane must be heated to vaporize it.

In this test, eight tanks of butane-propane will be manifolded as shown in figure 1, and connected through a liquid line filter to a Thermoelectric Generator and Vaporizer Assembly, Model 34505. The tanks will be installed upside-down in a rack so that the propane, which has become a gas, will push the liquid butane down through the connecting lines and the filter into the vaporizer. The vaporizer will heat the liquid butane until it boils, providing gaseous butane to the TEG, where it will be burned.

3. ASSEMBLY AND TEST

Assemble one Thermoelectric Generator and Vaporizer Assembly using the 3M TEG Model 515 now at LP7 and the parts shipped from Garland. Follow the instructions given on the enclosed drawings and in the Instruction Manual M34505. It is recommended this work be done near the CRB, where a variety of tools and the machine shop are available.

Fabricate a wooden rack to support the eight fuel supply tanks. The tanks will be placed on the rack with their outlet valves down.

Assemble the entire system in the CRB area. Check all plumbing for leaks and reseal as required.

Light the TEG burner, following instructions in Manual M34505. The 3M TEG requires no special jets for butane operation but should be adjusted as follows:

Adjust fuel-air mixture for maximum no-load thermopile output voltage (V_o). At the same time adjust fuel pressure to keep V_o at its rated value (as stamped on the TEG nameplate). DO NOT ALLOW IT TO REACH 8.0 V. This will burn the thermopile.

Dummy load the TEG with a 100 Ω , 20 W resistor and operate over night.

4. INSTALLATION

Install the tested system at the LP7 vault site, and recheck all pipe and valve connections for leaks. Light the TEG. Check the voltage and current furnished after TEG operation has stabilized. Readjust fuel-air mixture and fuel pressure, if required.

5. OPERATIONAL TEST

Use the system to routinely furnish power to the LP7 seismograph equipment. For the first month of operation, visit the site weekly to inspect the system and to check TEG thermopile voltage. Thereafter, make these checks once per month.

6. REPORTS AND DATA

Record all measurements made during the assembly, test, installation, and operational test and furnish these to the Program Manager with each monthly report.

Take 4 x 5 photos of the test setup at the CRB and of the installation at LP7 and send these to the Program Manager.

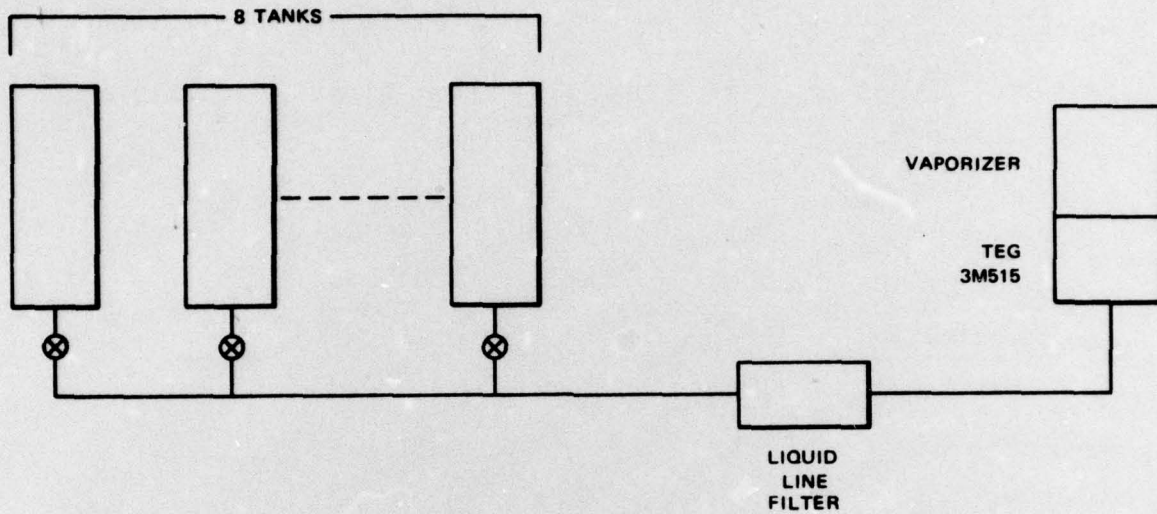

Figure 1. System block diagram

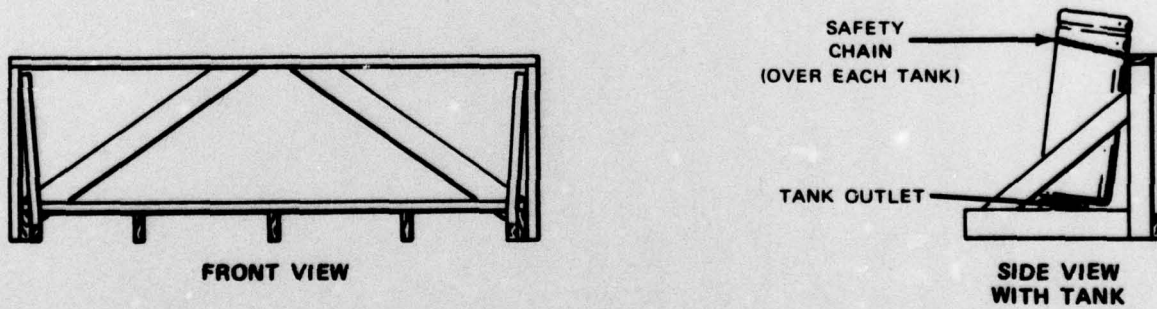

Figure 2. Suggested tank rack

APPENDIX 4 to TECHNICAL REPORT NO. 76-7

ARTICLE FROM THE PAYSON ROUNDUP ON THE
CLOSING OF TFSO

Payson Roundup

THE NEWSPAPER OF THE MOGOLLON RIM AREA

Vol. 30 No. 17

PAYSON, ARIZONA

March 6, 1975

15c

Forest Seismology Observatory is being shutdown after 10 years

by R. Robertson

The closing of the Tonto Forest Seismological Observatory has been announced by the Federal Government. The operation will be phased out quickly because "they have completed the research for which the station was intended" according to a spokesman.

Dr. Carl Romney, assistant director of the nuclear monitoring research office of the Defense Advanced Research Projects Agency in Washington, D.C., told the Roundup that the station was one of five under government contract that has been closed.

The facility is located east of Payson about one mile north of Highway 260 between here and Star Valley.

"The station was designed to test some concepts and develop techniques of the detection of nuclear explosions in line with the national test ban problems," Romney said.

This is the last station to be shut down of the five. It was termed "the best in operation."

The observatory had sensors located within several miles around Payson that detected movements of the earth. Earthquakes were pin-pointed as a part of the project. Over 1,000 miles of cable connected the field stations to the main facility. Banks of computers and recorders continuously monitored for underground disturbances.

Much of the work done at the observatory was "classified information" according to the government and even authorized tourists were not allowed to photograph the inside.

A congressional committee began studying Payson as a possible site for the seismograph in early 1961 and ground was broken for the building on April 6, 1963. The role of the seismograph at the time of its construction was described as a research tool for "probing the important secrets of nature, such as the origins of earthquakes."

Dr. Frank Press, a national leader in seismology, spoke at the formal ceremonies here in 1963 and said the problems of interference of the static unrest of the earth, originating in wind and wave, and the need to improve seismic signals were being considered.

Adrian Sanford Fisher, deputy director of the U. S. Arms Control and Disarmament Agency, stressed the need of a nuclear test ban treaty and the talked of the role the seismograph would play in its enforcement.

The Cuban Missile Crisis was at its peak six months prior to the dedication of the Payson facility.

Dr. Charles Bates, of the Department of Defense, said at the groundbreaking, "This experimental observatory is the finest of its kind ever built for the pursuit of seismology. It is the direct consequence of a decision made just four years ago at the White House (by President Eisenhower) that the United States must develop an advanced seismological research facility where technology, rather than cost or real estate problems, was the limiting factor."

The "christening" of the facility was done with a charge of dynamite set off by Bob Schmidt, president of the Payson Chamber of Commerce.

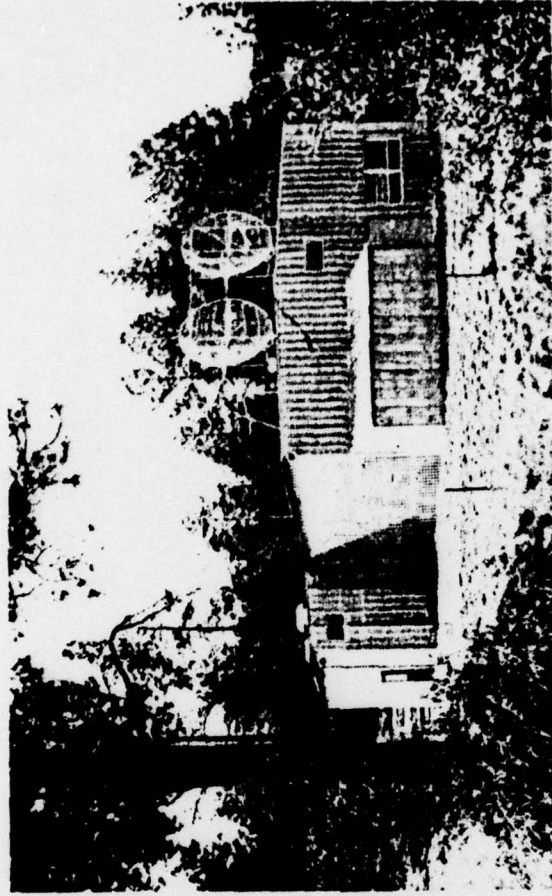

Roundup Photo

Tonto Forest Seismological Observatory

An open house was held and attended by 800 persons.

Payson's first notification of its being considered as the site of the observatory was met with mixed reactions; as reported in the July 28, 1961, edition of The Roundup:

"A recent announcement out of Washington told of a new Air Force installation scheduled for Payson. The news item (of July 19) lacked just enough detail to start the usual wild rumors around town. As an example, we heard the rumor involving atomic contamination and another had it that the installation would employ thousands of people."

The article reported the project would cost 10 million to build, would employ relatively few persons and those it did employ would be highly trained persons, no local. At present there are five em-

ployed at the site, at one time, as many as 25 were working there.

When the project began, the government awarded the contract to United Electrodynamics, Inc. (UED) of Alexandria, Va., and then to Teledyne Corp. It was later awarded to Geotech. Teledyne purchased UED and Geotech and was awarded the contract by the government. It still has the contract through July 1. It's home office, in Garland, Tex., is expected to set up the closing schedule for the facility.

Plant Manager Gayle Stanfill said the closing may take as much as a year. Romney reported that the facility may be sold like two other observatories. One of those sites, in Vernal, Utah, was taken over by the University of Utah.

The government will advertise the buildings and equipment it intends to dispose of.

APPENDIX 5 to TECHNICAL REPORT NO. 76-7

TWX CONFIRMING VERBAL REQUEST OF T.C.P.

TWX CONFIRMING VERBAL REQUEST OF T.C.P.

GEOTECH GARL

PATPRO PAFB

TLX8 PATRICK AFB FL MAR 5 11:11 A M

MSG NBR 3-70

FM: BASE PROCUREMENT OFC PATRICK AFB FL

TO: TELEDYNE GEOTECH

ATTN: J. SCHIRARD

3401 SHILOH ROAD

GARLAND TX 75040

SUBJECT: TONTO FOREST SEISMOLOGICAL OBSERVATORY TFSO

1. CONFIRMING OUR TELECON 28 FEB 75 THE PROJECT OFFICE HAS ADVISED THAT ARPA HAS DETERMINED THAT THE OPERATION OF THE TFSO IS NO LONGER REQUIRED. ALL WORK IN ACCORDANCE WITH TASKS 4.1.1, 4.1.2, 4.1.3 and 4.2 OF THE STATEMENT OF WORK FOR PROJECT VT/4704 IS TO BE DISCONTINUED AS OF 28 FEB 75.

2. THE PROJECT OFFICE HAS FURTHER ADVISED THAT THE FOLLOWING SHOULD BE ADDED TO THE STATEMENT OF WORK AS TASK 4.4:

"4.4 OBSERVATORY CLOSE-OUT.

4.4.1 - WITHIN 30 DAYS, THE CONTRACTOR SHALL PREPARE AN INVENTORY OF ALL TECHNICAL EQUIPMENT, INCLUDING THE OPERATIONAL CONDITION OF EACH ITEM.

4.4.2 - THE CONTRACTOR SHALL DISMANTLE AND PREPARE FOR SHIPMENT ALL TECHNICAL EQUIPMENT OF THE OBSERVATORY. NO ACTION SHOULD BE TAKEN BY THE CONTRACTOR FOR THE CLOSE-OUT OF REAL PROPERTY, SPIRAL-4 DATA CABLES ON THE GROUND, VAULTS, OR ROADS."

THE WORK INDICATED ABOVE SHOULD BE COMPLETED BY 30 JUN 75 AND IT IS DEEMED THAT THE FUNDS PRESENTLY AVAILABLE ON THE CONTRACT ARE SUFFICIENT FOR THIS ACTION. REQUEST YOUR COMMENTS BE FURNISHED WITH REGARD TO THE SCHEDULING AND FUNDING IN ORDER THAT A SUPPLEMENTAL AGREEMENT MAY BE ISSUED TO THE SUBJECT CONTRACT.

JOSEPH W. GIBBONS, CONTRACTING OFFICER R & D DIV

GEOTECH GARL

APPENDIX 6 to TECHNICAL REPORT NO. 76-7

TASK CHANGE PROPOSAL, P-2473 FOR CONTRACT F08606-74-C-0007

TASK CHANGE PROPOSAL		TCP NUMBER
		DATE 13 March 1975
		PAGE 1 OF 7 PAGES
TITLE Close-out of the Tonto Forest Seismological Observatory		
ITEM AFFECTED (Identify contracts and references, systems, subsystems, and, when possible software items affected by proposal) Contract F08606-74-C-0007 Affected items: Tasks 4.1.1, 4.1.2, 4.1.3, 4.2, 4.4.1 and 4.4.2.		
NEED FOR TASK CHANGE (Explain how and when need was recognized, impact of not making change, and how change will improve system) The decision of the Air Force to stop operation of the TFSO and to dismantle and prepare for shipment all technical equipment used there requires that Contract F08606-74-C-0007 be changed to accommodate this decision.		
DESCRIPTION OF PROPOSED CHANGE (Enter a detailed description of the proposed task, including man-hours and any special equipment required) See attached paragraphs, same subject.		
ALTERNATIVES TO PROPOSED CHANGE (Explain reasons for/against each alternative, and its cost) See attached paragraphs, same subject.		
COST ESTIMATE (Contract cost adjustment required for the task) See attached paragraph, same subject.	TASK SCHEDULE (Enter schedule for completing work and, when applicable, date for submittal of results) See attached sheet, same subject.	
URGENCY CONSIDERATIONS (When applicable, describe any condition bearing on the urgency of obtaining approval for change) None		

DESCRIPTION OF PROPOSED CHANGE

On 28 February 1975, we stopped the routine operation of the TFSO and propose to do no further work under the following tasks:

- Task 4.1.1 Operate TFSO
- Task 4.1.2 Quality Control Data
- Task 4.1.3 Provide Facilities and Assistance
- Task 4.2 Conduct Research Work

We propose to continue work of maintaining facilities under Task 4.1.4 and the work of fulfilling Contract Data Requirements under Task 5.0.

Rollup of technical equipment will be undertaken as called for in the following new tasks to be added to the Statement of Work for the subject contract.

TASK 4.4 OBSERVATORY CLOSE-OUT

- 4.4.1 Within 30 days, the contractor shall prepare an inventory of all technical equipment, including the operational condition of each item.
- 4.4.2 The contractor shall dismantle and prepare for shipment all technical equipment of the observatory. No action should be taken by the contractor for the close-out of real property, spiral-4 data cables on the ground, vaults, or roads.

All technical equipment will be removed from the array field sites and brought to the Central Recording for temporary storage before being packed and shipped to destinations designated by the Project Officer. The technical equipment will include items like seismometers, amplifiers, thermoelectric generators, radio telemetry sets, antennas and radio towers. Real property items, spiral-4 cable, vaults and cable junction boxes will not be picked up. No remote site, access road, cable trail nor other land restoration will be undertaken. The type of packaging provided for the technical equipment will depend upon its destination, and can vary from wood crates to cardboard cartons to no packaging (if a shipment is to be made by furniture van).

The objective of the proposed work will be to effect an orderly, well-documented pickup and distribution of the observatory technical equipment.

ALTERNATIVE TO PROPOSED CHANGE

The Air Force could terminate its operation of the TFSO by turning over the observatory and all related properties to an educational or research institution. The economics and feasibility for such an action cannot be assessed by the contractor.

COST ESTIMATE

The total funds presently available on the contract are sufficient to accomplish this work. (This includes both R&D and O&M funds.)

TASK SCHEDULE

All work will be scheduled to permit withdrawal of all personnel from the observatory by 30 June, 1975, as shown in table 1. It should be noted, however, that timely information concerning disposition of all items must be received from the Project Office if this schedule is to be met.

The preparation and submission of the final report on this contract will be accomplished by 30 August 1975.

Table 1. Task schedule

TASK	1975					
	Mar	Apr	May	Jun	Jul	Aug
4.1.4 Maintain Observatory						
4.4.1 Inventory						
4.4.2 Dismantle and Prepare						
5.0 Data						