

AD-A035 433

INTERNATIONAL HARVESTER CO HINSDALE ILL MFG SERVICES F/G 11/6  
ISOTHERMAL HEAT TREATMENT FOR HIGH STRENGTH DUCTILE IRON CASTIN--ETC(U)  
JUN 76 C J CARTER, R E WAHLSTROM DAAE07-73-C-0308

UNCLASSIFIED

TACOM-TR-12167

NL

1 of 1  
ADAO35433

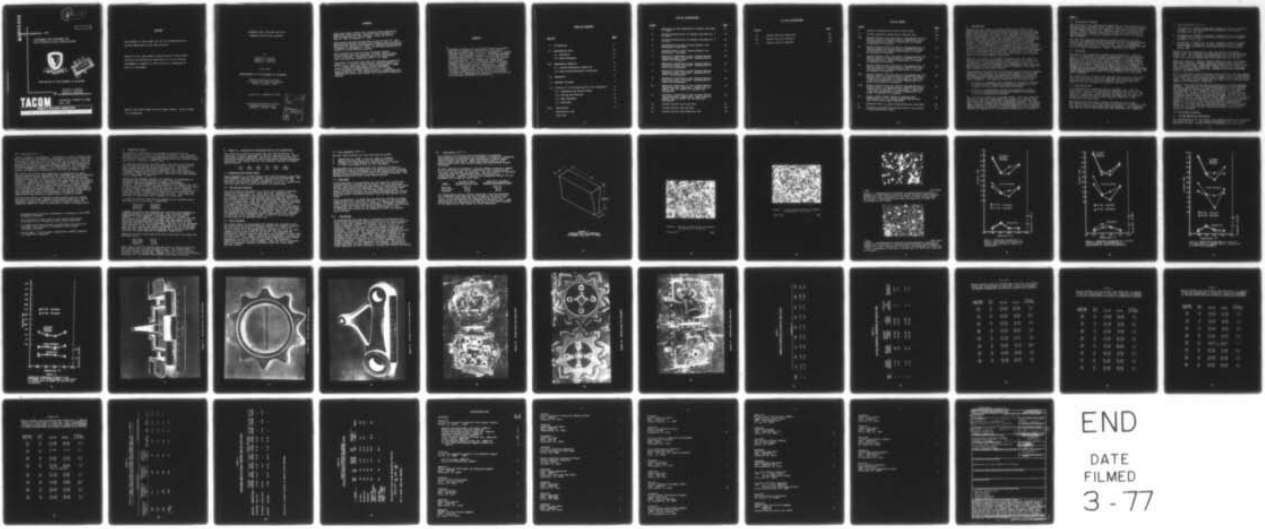

END  
DATE  
FILMED  
3 - 77

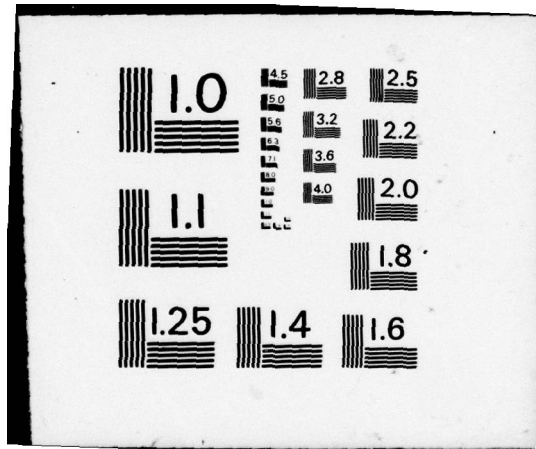

ADAO35433

(18) (12)  
NW

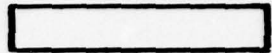

TECHNICAL REPORT NO. 12167

ISOTHERMAL HEAT TREATMENT FOR  
HIGH STRENGTH DUCTILE IRON CASTINGS



Distribution of this document is unlimited.

by

Clarence J. Carter  
Robert E. Wahlstrom  
Raymond A. Cellitti

**TACOM**

Contract No. DAAE07-73-C-0308  
June, 1976

**MOBILITY SYSTEMS LABORATORY**

U.S. ARMY TANK AUTOMOTIVE COMMAND Warren, Michigan

See Form 1493

NOTICES

The findings in this report are not to be construed as an official Department of the Army position.

Mention of any trade names or manufacturers in this report shall not be construed as advertising nor as an official indorsement or approval of such products or companies by the U. S. Government.

Destroy this report when it is no longer needed. Do not return it to originator.

ISOTHERMAL HEAT TREATMENT FOR HIGH  
STRENGTH DUCTILE IRON CASTINGS

by

Clarence J. Carter  
Robert E. Wahlstrom  
Raymond A. Cellitti

June 1976

**Distribution of this document is unlimited.**

Mobility Systems Laboratory  
U.S. Army Tank Automotive Command  
Warren, Michigan 48090

Contract No. DAAE07-73-C-0308

International Harvester Company  
Manufacturing Services  
Hinsdale, Illinois 60521

ACCESSION FOR	
NTIS	White Section <input checked="" type="checkbox"/>
DDC	Buff Section <input type="checkbox"/>
UNANNOUNCED	<input type="checkbox"/>
JUSTIFICATION	<input type="checkbox"/>
BY _____	
DISTRIBUTION/AVAILABILITY CODES	
Dist.	AVAIL. AND/OR SPECIAL
A	

## FOREWORD

This final report covers work performed under Contract No. DAAE07-73-C-0308 entitled "Isothermal Heat Treatment for High Strength Ductile Iron Castings" during the period June 27, 1973 to November 17, 1975.

This project has been accomplished as part of the U.S. Army Manufacturing Methods and Technology Program which has as its objective the timely establishment of manufacturing processes, techniques or equipment to insure the efficient production of current or future defense programs.

This contract with International Harvester Company, Manufacturing Services, Hinsdale, Illinois, was initiated by U.S. Army Tank - Automotive Command and accomplished under the technical direction of Mr. G. B. Singh.

The project activities were under the technical guidance of Messrs. R. A. Cellitti, Metallurgical Services Manager and R. P. O'Shea, Supervisor Metal Process Development. Other areas of technical responsibility were provided by R. E. Wahlstrom, Research Associate and C. J. Carter, Research Associate. The authors gratefully acknowledge the assistance of other staff members who contributed substantial efforts.

### ABSTRACT

↓ Austempered ductile iron containing nickel was investigated as an economical substitute for alloy steel forgings currently used as critical components in armored vehicles (M113 personnel carrier). An optimum austemper treatment evolved which resulted in a cast ductile iron which delivered 135 ksi ultimate, 97 ksi yield strength and 11% elongation. Low temperature (-40F) impact toughness was 3 ft-lbs and rotational bending fatigue strength was 62.5 ksi at room temperature. A quantity of select components namely, suspension arm, sprocket and track shoe were cast, heat treated and finished machined to demonstrate the applicability of the manufacturing process as well as the service performance of these cast components when subjected to field testing under extreme environmental conditions. ↗

## TABLE OF CONTENTS

<u>Section</u>	<u>Page</u>
I. Introduction	1
II. Experimental Work	2
2.1 Materials	2
2.2 Heat Treatments	2
III. Experimental Results	3
3.1 As-Cast Mechanical Properties	3
3.2 Heat Treated Mechanical Properties	4
IV. Discussion	5
V. Economic Analysis	7
VI. Production of Prototype Ductile Iron Components	8
6.1 Components and Pattern Molds	8
6.2 Melting and Treating	8
6.3 Heat Treatment	8
6.4 Machining	9
VII. Conclusions	9
Distribution List	
1473 Form	

## LIST OF ILLUSTRATIONS

<u>Figure</u>		<u>Page</u>
1.	Configuration and Dimensions of Nodular Iron Cast "Y" Block	11
2.	As-Cast Microstructure of Nodular Iron Heat No. 1 (0.75 Ni)	12
3.	As-Cast Microstructure of Nodular Iron Heat No. 2 (1.5 Ni)	13
4.	Microstructure of Heat Treated Nodular Iron Containing 0.75% Nickel	14
5.	Microstructure of Heat Treated Nodular Iron Containing 1.5% Nickel	14
6.	Mechanical Properties of Heat Treated Nodular Iron Containing 0.75% Nickel, Austenitized at 1600°F and Austempered	15
7.	Mechanical Properties of Heat Treated Nodular Iron Containing 0.70% Nickel, Austenitized at 1650°F and Austempered	16
8.	Mechanical Properties of Heat Treated Nodular Iron Containing 1.5% Nickel, Austenitized at 1600°F and Austempered	17
9.	Mechanical Properties of Heat Treated Nodular Iron Containing 1.5% Nickel, Austenitized at 1650°F and Austempered	18
10.	Mechanical Properties of Heat Treated Nodular Iron Containing 1.5% Nickel, Austenitized at 1600°F, Held at 1350°F for One Hour and Austempered	19
11.	Mechanical Properties of Heat Treated Nodular Iron Containing 0.75% Nickel, Austenitized at 1600°F, Held at 1350°F for One Hour and Austempered	20
12.	As-Cast Ductile Iron Track Shoe	21
13.	As-Cast Ductile Iron Sprocket	22
14.	As-Cast Ductile Iron Suspension Arm	23

LIST OF ILLUSTRATIONS

<u>Figure</u>		<u>Page</u>
15.	Pattern Mold for Track Shoe	24
16.	Pattern Mold for Sprocket	25
17.	Pattern Mold for Road Arm	26

LIST OF TABLES

<u>TABLE</u>		<u>PAGE</u>
I.	Chemical Composition of Ductile Iron Alloys	27
II.	As-Cast Mechanical Properties of Ductile Iron	28
III.	Tensile Property Data for Ductile Iron Containing 0.75 Percent Nickel and Austenitized at 1600°F for 1 Hour and Austempered at Various Temperatures for Either 30 Minutes or 60 Minutes	29
IV.	Tensile Property Data for Ductile Iron Containing 1.5 Percent Nickel and Austenitized at 1600°F for 1 Hour and Austempered at Various Temperatures for Either 30 Minutes or 60 Minutes	30
V.	Tensile Property Data for Ductile Iron Containing 0.75 Percent Nickel and Austenitized at 1650°F for 1 Hour and Austempered at Various Temperatures for Either 30 Minutes or 60 Minutes	31
VI.	Tensile Property Data for Ductile Iron Containing 1.5 Percent Nickel and Austenitized at 1650°F for 1 Hour and Austempered at Various Temperatures for Either 30 Minutes or 60 Minutes	32
VII.	Tensile Property Data for Ductile Iron Containing 0.75 Percent Nickel and Austenitized at 1600°F for 1 Hour, Transferred to and Held in a Salt Bath at 1350 F for 1 Hour and Austempered at Various Temperatures for Either 30 Minutes or 60 Minutes	33
VIII.	Tensile Property Data for Ductile Iron Containing 1.5 Percent Nickel and Austenitized at 1600°F for 1 Hour, Transferred to and Held in a Salt Bath at 1350°F for 1 Hour and Austempered at Various Temperatures for Either 30 Minutes or 60 Minutes	34
IX.	Charpy V-Notch Impact Values at Selected Test Temperatures for 0.75 Percent Nickel Ductile Cast Iron Given Various Heat Treatments	35
X.	Estimated Costs to Supply Selected Ductile Iron Parts	36
XI.	Mechanical Properties of Various Ductile Iron Grades at Room Temperature (80°F)	37

## I. Introduction

Ductile iron is a family of ferrous alloys which combines the fabrication ease and economical benefits of gray iron (low melting points, good fluidity and castability, excellent machinability and good wear resistance) with many of the engineering advantages of steel (high strength, ductility, hot workability and hardenability). As with most ferrous alloys, the strength and plasticity of ductile iron is contingent upon heat treat methods as well as alloying additions. Increased strength results in decreased ductility. Further, as the temperature of the operating or service environment is decreased, the plasticity and toughness of ductile iron are also adversely affected. Thus conventionally processed ductile irons have not found acceptance in applications that encounter high loading and low temperatures of nil-ductility. Accordingly, ductile cast irons have not been employed interchangeably with steel components owing to the aforementioned limitations.

Vehicular components are required to operate in a wide range of temperatures ranging from possibly 125°F to -65°F and as such must be fabricated in materials capable of providing the required engineering properties throughout this temperature range. Thus the use of ductile iron for critical vehicular components subjected to high loading has been quite limited.

The purpose of this work was to investigate the influence of various aspects of heat treatment of ductile iron castings to secure high strengths in conjunction with improved low temperature ductility and toughness and thereby provide a cost effective alternative to steel components. The specific objectives of the program were:

1. To evolve an isothermal heat treatment and chemistry influence of ductile iron to improve the mechanical properties of the component for use in low temperature environment.
2. To evolve a manufacturing process with sufficient quality control for reproducible and constant mechanical properties of items processed by this method.

The program was staged as a two-phase effort. The first phase was primarily focused on ascertaining the influence of chemistry and isothermal heat treat variables in obtaining a ductile cast iron with acceptable strength and low temperature toughness. The second phase sought to utilize the information generated in phase one and explore further the production, heat treatment and field evaluation of selected components in the preferred metallurgical conditions.

## PHASE I

### II. Experimental Program

The objective of the experimental program was to develop ductile iron alloys and heat treatments which would be capable of providing improved low temperature ductility and toughness at the required high strength levels. These alloys and heat treatments were to be compatible with foundry and heat treatment operations so that full exploitation in the manufacture of vehicular components could be made if the program were successful.

The Phase One experimental program utilized Y-blocks as the test approach for assessing chemical composition and heat treatment effects on mechanical properties of ductile irons. In all, approximately 230 Y-blocks were cast in two ductile iron alloys and twenty-four heat treatments were investigated. Figure 1 typifies the Y-block.

#### 2.1 Materials

Two ductile iron alloys were selected for investigation. The constraints in specifying the chemical composition were to maintain the silicon level below 2.75 percent consistent with a suitable carbon equivalent and to utilize two levels of nickel as alloying elements. The reason for controlling the silicon content to a low level is to minimize the effects of raising the impact transition temperature at high silicon levels. Nickel was selected as an alloying element because it has no known deleterious effects and because of its potential to increase hardenability, strength and toughness in ductile iron. The target compositions for nickel of two iron alloys were 0.75 percent and 1.50 percent.

One hundred and ten Y-blocks were produced from each heat (220 total). To further quantify the as-cast properties, metallographic samples were examined and two 0.505-inch diameter tensile specimens were prepared from the Y-blocks and tested for each heat.

#### 2.2 Heat Treatments

The isothermal heat treatments were an austemper type. That is, austenitize, quench to an intermediate temperature at which bainite would form, hold until transformation is complete and air cool. The austemper (isothermal quench) approach was undertaken because this type of treatment tends to produce improved toughness at high strengths in ferrous alloys.

One hundred and forty-eight Y-blocks (74 from the 0.75 nickel heat and 74 from the 1.50 nickel heat) were sectioned to produce 1 inch by 1 inch by 6 inch test coupons for heat treatment. Test specimens from each of the two heats were given the following heat treatments.

## 2.2 Heat Treatments (Cont'd.)

1. Austenitize at 1600°F for one hour, isothermal quench: (austemper) to 600°F, 700, 800 and 900°F for 30 minutes and 60 minutes, followed by an air cool.
2. Austenitize at 1650°F for one hour, isothermal quench (austemper) to 600°F, 700°F, 800°F and 900°F for 30 minutes and 60 minutes, followed by an air cool.
3. Austenitize at 1600°F for one hour, isothermal quench to 1350°F for one hour, followed by a second isothermal quench to 600°F, 700°F, 800°F and 900°F for 30 minutes and 60 minutes followed by air cool.

Austenitizing was conducted in a salt bath furnace containing a neutral salt. All austenitizing temperatures were controlled within a 5°F range. The isothermal transformations were also performed in molten salt bath and temperatures were within  $\pm 10^\circ\text{F}$  of the aim.

After heat treatment, Brinell hardness tests were taken and Standard ASTM A536 0.505 inch diameter tensile bars were machined from the heat treated specimens. After machining the specimens, tensile tests were conducted at room temperature. Charpy V-notch test bars were machined in "coupons" which were heat treated in preferred conditions based on the tensile data.

Review of the heat treat experimental matrix indicates that the results of the program will discern the effect of nickel control, austenitizing temperature, two stage isothermal quench versus single stage isothermal quench, isothermal quench temperature and time of the isothermal quench temperature on mechanical properties.

Figures 4 and 5 show typical microstructures of the 2-stage austemper treatment. Examination of these photomicrographs clearly indicates the hardenability effects of nickel in ductile iron. The two-stage heat treatment of the 0.75 percent nickel ductile iron specimen indicates that one hour 1350°F is sufficient time to complete transformation from austenite to ferrite and pearlite. Whereas with the 1.5 percent nickel ductile iron, holding at 1350°F for one hour is not sufficient to start transformation at this temperature. The subsequent quench to 700°F and holding for 1 hour resulted in transforming the austenitic to bainite. This effect of nickel to significantly shift the continuous cooling transformation curve of ductile iron is noteworthy and allows for the potential application of austempering to produce 100 percent bainite structures in parts having rather thick cross sections.

## III. Experimental Results

### 3.1 As-Cast Mechanical Properties

The compositions of the two ductile iron alloys produced for this study are listed in Table I. The carbon equivalent of Heat 1 is 4.29 and for Heat 2 is 4.24. Review of Table I indicates that the nominal

### 3.1 As-Cast Mechanical Properties (Cont'd.)

nickel aims of 0.75 percent and 1.50 percent were reasonably well met, namely 0.70 percent and 1.48 percent, respectively.

Figures 2 and 3 show the as-cast microstructure of the two ductile irons. The microstructure in both cases consisted of graphite spheroids surrounded by ferrite in a pearlitic matrix. The graphite morphology is predominately nodular Type I, ASTM A247.

Tensile bars were machined from Y-blocks poured in the 0.75 percent Ni and 1.5 percent Ni ductile irons. Duplicate 0.505-inch diameter tensile bars were prepared and tested from each heat. Also Brinell hardnesses were taken prior to machining the tensile bars. These data are listed in Table II. It was anticipated that a scatter in the as-cast hardness and tensile properties may be present in the test bars machined from the various Y-blocks. This apparent difference in properties is attributed to variations in shakeout time of the Y-blocks after casting. Y-blocks which were shaken out in a relatively short period of time after being poured would exhibit higher strengths and hardnesses than those allowed to in-mold cool for a longer period of time.

### 3.2 Heat Treated Mechanical Properties

As previously discussed, test coupons were machined from Y-blocks and a variety of isothermal heat treatments were performed. For each heat treatment two 1-inch by 1-inch by 6-inch test specimens were secured. After heat treatment, Brinell hardness determinations were made and standard 0.505-inch tensile bars were fabricated and tested. Tables III through IX list the tensile properties. Figures 6 through 11 depict these data. Ultimate tensile strength and yield strength appear to undergo a minimum in the austemper range of 700°F to 300°F. Elongation exhibits a maximum in the same temperature range.

A limited series of impact tests was conducted to typify and compare the low temperature toughness properties of the single stage and two-stage isothermal transformation heat treatments. The 0.75 percent nickel alloy was selected as the candidate material. The treatments which were selected were the ones exhibiting high strengths and ductilities, namely the 1650°F austenitizing and 700°F isothermal transformation for the single stage isothermal treatment and the 1600°F austenitizing with 1350°F intermediate treatment and 600°F isothermal treatment for the two stage treatment.

Impact tests were conducted at room temperature, 0°F, -20°F and -40°F. The test results are listed in Table IX. The impact properties range from approximately 5 to 8 ft-lbs at room temperature to 3 to 4 ft-lbs at -40°F. Examination of the fracture surfaces indicated that the room temperature tests were 100% fibrous whereas the -40°F tests were 0 percent fibrous. Accordingly, it can be assumed that the -40°F impact values are below the transition temperature and represent a plane strain failure.

#### IV. Discussion

A number of observations can be made from the data which have been presented. Included in these are:

1. Strength properties appear to go through a minimum in the 700-800°F range of isothermal transformation.
2. Ductility as measured by elongation exhibits a maximum in the 700-800°F temperature isothermal transformation.
3. The dependence of mechanical properties on the time of isothermal transformation is less sensitive for the 0.75 percent nickel ductile cast iron than with the 1.5 percent nickel ductile cast iron.
4. There is an effect of austenitizing temperature on the time/temperature transformation characteristics. Within the confines of the experimental matrix, this effect is more pronounced with the 0.75 percent nickel ductile cast iron.
5. The single-stage treatment exhibits higher strength characteristics than the two-stage treatment.
6. In comparing the single-stage treatment with the two-stage treatment, maximum strength with reasonably good ductility can be achieved via the single-stage route.
7. The optimum combination of high strength and high ductility appears to be attained at the 60 minute 700°F single-stage isothermal treatment.
8. With the 700°F isothermal heat treatment, the 0.75 percent nickel ductile cast iron has equivalent mechanical properties of the 1.5 percent nickel ductile cast iron.

The majority of the above observations can readily be explained in terms of the continuous cooling transformation curves for ductile cast irons. Apparently at 900 F the 60-minute isothermal treatment is not a sufficient length of time to form intermediate transformation products and quenching to room temperature produces substantial amounts of martensite. This metallurgical structure has high strength and low ductility. The isothermal transformation at 700-800°F produces a bainitic structure which has relatively high strength and good ductility. The isothermal treatment at 600°F probably induces a transformation to bainite and martensite which has higher strength but less ductility than the 700-800°F treatment.

Insofar as the time effects on the 0.75 percent nickel and 1.5 percent nickel ductile cast irons are concerned, during the isothermal treatments, the high nickel content is shifting the time/transformation curves to longer times. This shift is sufficient to influence the

#### IV. Discussion (Cont'd.)

amount of material transforming. Accordingly, in some instances there is a difference in the mechanical properties for the iron treated for 30 minutes as compared to the irons treated for 60 minutes. With the 0.75 percent nickel ductile cast iron, the time transformation curve appears to be situated at an intermediate time span and treatment for 30 minutes apparently completes the transformation. The treatment for the additional 30 minutes, in the 60 minutes treatment, does not produce any significant differences in the test bar section size.

The effects of austenitizing temperature on properties are again directly related to the time/temperature transformation characteristics. Austenitizing at 1650°F assures that the alloying elements go more readily into solution in the austenite than the 1600°F austenitizing treatment. Therefore the time/temperature characteristics are slightly shifted to longer times at 1650°F than at 1600°F. The more pronounced effect for the 0.75 percent nickel ductile cast iron merely reflects the sensitivity of the hardenability of this material when measured at 30 minutes or 60 minute intervals. The 1.5 percent nickel ductile cast iron has sufficient hardenability so that measured properties of iron isothermally treated for 60 minutes or 30 minutes is not significantly influenced by austenitizing at 1650 F or 1600 F.

The following factors predicated on test results favor an optimum selection of 0.75 nickel, 1650°F austenitizing temperature, and an isothermal treatment at 700°F for 1 hour in order to attain the properties sought for Phase II production of select prototype parts.

1. Optimum strength-ductility combination is effected at the 700°F isothermal treatment.
2. The 0.75 percent nickel ductile cast iron has equivalent properties as the 1.5 percent nickel ductile cast iron.
3. The single-stage heat treatment yields higher strengths with moderately high ductility as compared to the 2-stage isothermal treatment.
4. Longer times (1 hr) at higher temperatures (1650°F) improved low temperature toughness.

## V. Economic Analysis

The utility of isothermal heat treatment of ductile iron is dependent upon two factors, namely the capability of the processed material to meet the necessary mechanical property requirements and the relative economics of producing isothermally heat treated ductile iron parts as compared to steel parts.

The preceding discussion has shown that isothermally heat treated ductile iron has the potential capability for the manufacture of parts having appreciable strength and ductility. The final applicability of this approach to component parts would be to fabricate candidate parts and to field test them under controlled conditions. This type of evaluation, fabrication and field testing, will be undertaken in Phase II.

Insofar as the economic analysis is concerned, the comparison of isothermal heat treated ductile iron parts with steel components should be determined in terms of differences in costs: For the purposes of this analysis it is assumed that the difference in cost factors associated with the two alternatives occurs in the production of a part prior to machining and/or induction hardening. This assessment therefore concerns only a comparison of costs differences of producing a forged and heat treated part with isothermally heat treated ductile cast iron parts. Any induction hardening and machining cost is assumed to be the same.

In order to undertake this type of analysis three candidate parts were selected for evaluation. These were:

Track Shoe	K11646782
Sprocket	8673353
Road Arm	K10875006

A number of ductile iron foundries were contacted and requested to submit quotations for the above parts. Only one major foundry responded to these requests. The quoted costs are listed in Table X. If it is assumed that 50,000 sprockets, 100,000 road arms and 100,000 track shoes were purchased, the approximate as-cast costs per item would be \$15.37 for the road arms, \$8.88 for the track shoe and \$17.71 for the sprockets. The cost for the isothermal heat treatment is \$0.10 per pound. The weights are 36 lbs for the road arm, 19.6 lbs for the track shoe and 23.5 lbs for the sprocket. Thus the heat treat costs would be \$3.60, \$1.96 and \$2.35 for the road arm, the track shoe and the sprocket, respectively.

Combining the heat treat costs with the as-cast costs the prices are estimated to be:

Road Arms	\$18.97
Track Shoe	10.84
Sprocket	20.06

These costs should be compared with the costs of similar forged and heat treated (not induction hardened) parts. The International Harvester Company has not been able to secure these cost data from suppliers of these components. However, the U.S. Army can quite readily determine this information from current procurement contracts.

## VI. Phase II - Production of Prototype Ductile Iron Components

This phase was primarily concerned with the cost production and processing of select components of the M113 armored vehicle. During this phase, patterns were made, preliminary casts were poured and pattern molds were reworked to modify and correct casting dimensional tolerances. The nominal ductile iron chemistry (percent by weight) was as follows:

<u>C</u>	<u>Si</u>	<u>Mn</u>	<u>Cr</u>	<u>Ni</u>	<u>Mg</u>
3.40	2.60	0.60	0.10	0.75	0.058

### 6.1 Components and Pattern Molds

Three components of the M113 vehicle were selected namely, track shoe P/N K11646782, sprocket P/N 8673353, and road arm P/N k10875006. The cast parts are pictorially shown in Figures 12, 13 and 14. The patterns are pictorially shown in Figures 15, 16 and 17, respectively. All parts were cast in green sand molds with shell cores.

### 6.2 Melting and Treating

The charge make up was melted in a silica lined coreless induction furnace of 20 tons capacity. After melt down, chemistry and temperature adjustments, the molten metal was transferred (ladle) to a channel induction 50-ton holding furnace where the temperature was adjusted to maintain the desired range and chemistry (C, Si, S and Cu) was monitored. From the holding furnace the metal was poured into a treatment ladle (4000 lbs). The treatment comprised additions of ceramic coated pure magnesium, 75% Ferrosilicon, rare earth silicides and mischmetal. Following treatment, the metal was poured into a transport ladle (600 lbs) where nickel and final inoculations of 75% Ferrosilicon were added. A temperature aim of 2400 F to 2500 F was maintained during pouring into the molds. Wedge chill specimens and chemistry were continuously checked immediately after treatment or additions to the treatment ladle. A total of 418 track shoes, 20 road arms and 10 sprockets were cast.

### 6.3 Heat Treatment

The initial phase had established the optimum heat treatment cycle for conferring the required strength coupled with adequate ductility. The heat treat cycle was an austenitic treatment at 1650 F for 1 hour followed by an isothermal quench and hold for 1 hour at 700 F. Inasmuch as the section size of the initial test specimens was significantly smaller than the cast parts, an adjustment of hold time at quench was made to assure a complete transformation to bainite for the cast parts. The holding time at quench temperature was extended accordingly to provide 1 hour of hold time at the isothermal temperature per inch of part thickness. This plan was in conformity with the isothermal treatment previously given the 1-inch thick specimen coupons.

### 6.3 Heat Treatment (Cont'd.)

The heat treat schedule for cast parts was as follows:

1. Austenitize at 1650F, 1 hour per inch of thickness
2. Quench in molten neutral salt at 700F for 1/2 hour
3. Transfer to a draw furnace at 700F and hold for balance of time to correspond with the part thickness.

The sprockets and track shoes were also induction hardened at preferential sites as designated by the appropriate specifications. The pattern of induction hardened sites was inspected by sectioning several parts and measuring the extent of localized hardening. The sectioned areas were noted to meet specifications.

### 6.4 Machining

Finish machining of the sprockets and road arms were carried out routinely with no attendant difficulties. With the track shoes, however, some difficulties were encountered in positioning the shoes for accurate location and subsequent drilling of track pin holes using a production fixture for drilling forged steel shoes. A solution to this difficulty was provided by redesigning the fixture which permitted a referenced location from the cast surface of the gusset.

Prior to machining, the shoes were examined for flatness to assure compatibility with production tooling. A number of the shoes were rejected due to an "out-of-flat" condition. Subsequent attempts to cold or warm-straighten these parts resulted in cracks and fractures. Consequently, as a result of the above difficulties, a total of 136 shoes were rubberized and assembled to meet the required specifications.

## VII. Conclusions

An investigation was undertaken to determine the feasibility of substituting isothermally treated ductile iron for certain critical forged alloy steel components currently used in the M113 armored vehicle personnel carrier. An economic analysis as well as material behavior study under static and dynamic conditions were conducted. The cast ductile iron material with an appropriate isothermal or austemper heat treatment delivered acceptable tensile strength and ductility. Low temperature (-40F) toughness and fatigue properties were considerably improved in contrast to conventional ductile iron grades. Low temperature toughness of the isothermal grade does not achieve the toughness capabilities of forged alloy steel. However, it is felt that toughness is not a primary requisite for the components investigated. The material properties which are more relevant to the intended application of these components are wear resistance, strength and fatigue resistance.

VII. Conclusions (Cont'd.)

While several difficulties were encountered in processing (straightening and machining) the prototypes, it should be recognized that production tooling and layout methods were oriented toward current forged steel parts. Other less severe areas or minor contributing factors were pattern design and miscellaneous foundry techniques.

An exact comparative economical analysis between producing a forged, heat-treated steel part and an isothermally heat-treated ductile iron part was difficult to ascertain. The cost incurred in machining a prototype part is considerably higher than machining a production part. However, a partial cost comparison between the two processes can be made as listed below.

<u>Item</u>	<u>As-Cast &amp; Heat-Treated Ductile Iron</u>	<u>Completely Processed Forging (Approximate Cost)</u>
Road Arm	\$18.97	\$100.00
Track Shoe	10.84	20.00
Sprocket	20.06	80.00

The forged parts contain tooling, machining, induction hardening and inspection costs which are not included in the ductile iron parts. It is anticipated that these production costs will be approximately the same with the exception of machining cost. Less machining will be encountered with the ductile iron parts inasmuch as the parts can be cast closer to finish dimensions.

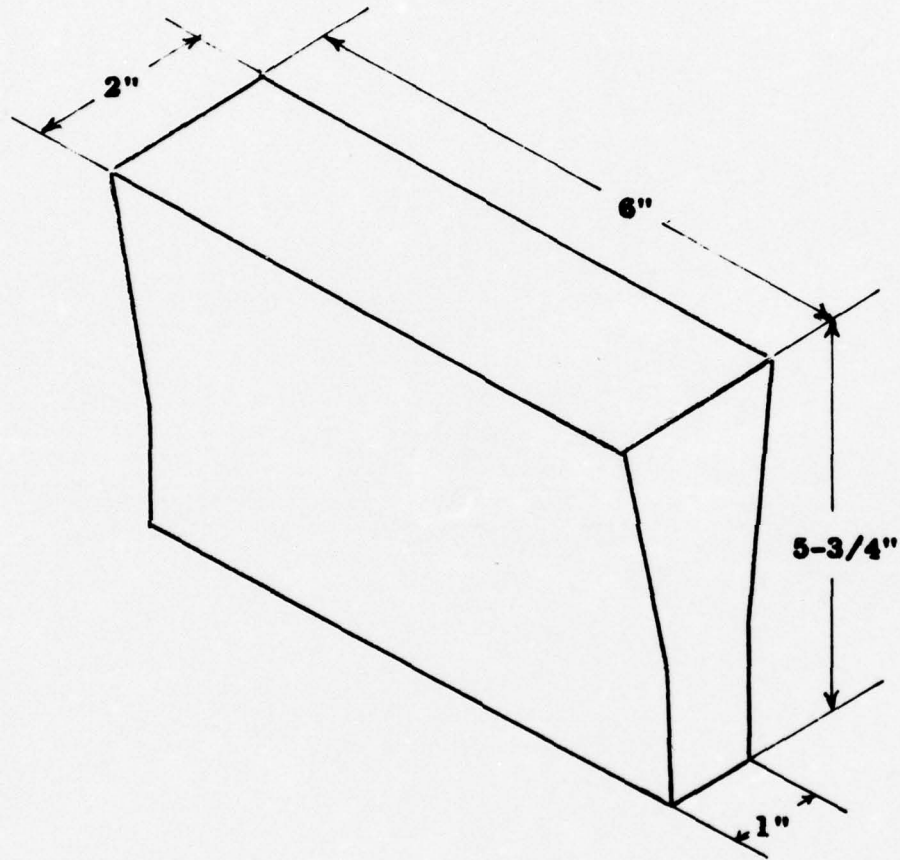

**Figure 1**  
**Configuration and Dimensions**  
**of Medular Iron Cast "Y" Block**

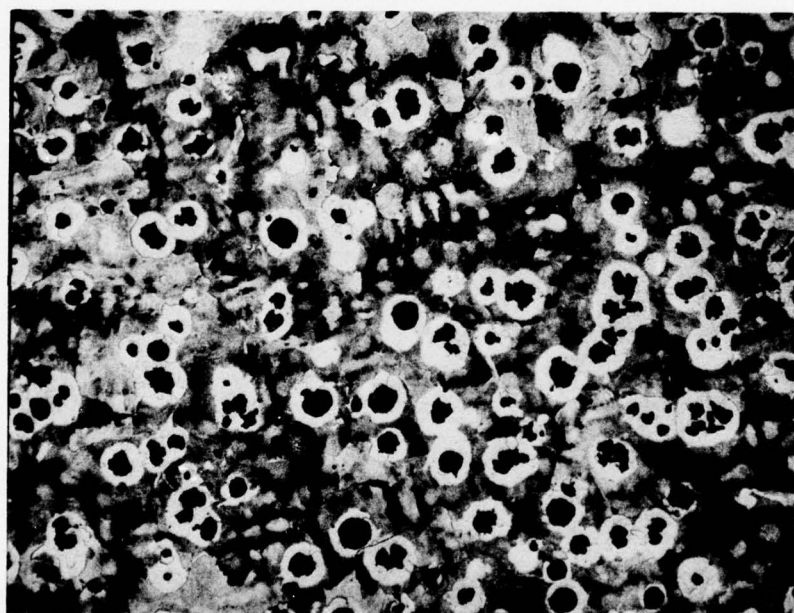

Figure 2 As-Cast Microstructure of Nodular  
Iron Heat No. 1 (0.75 Ni)

Nital Etch

100X

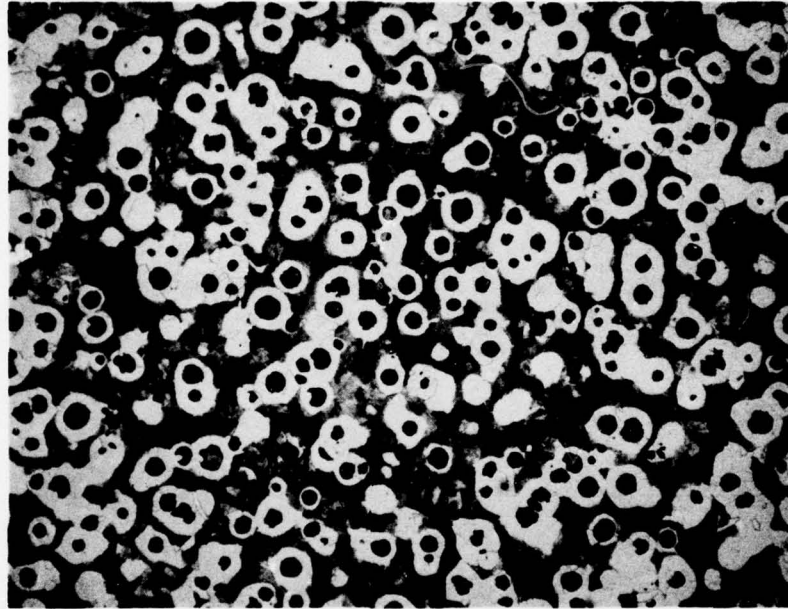
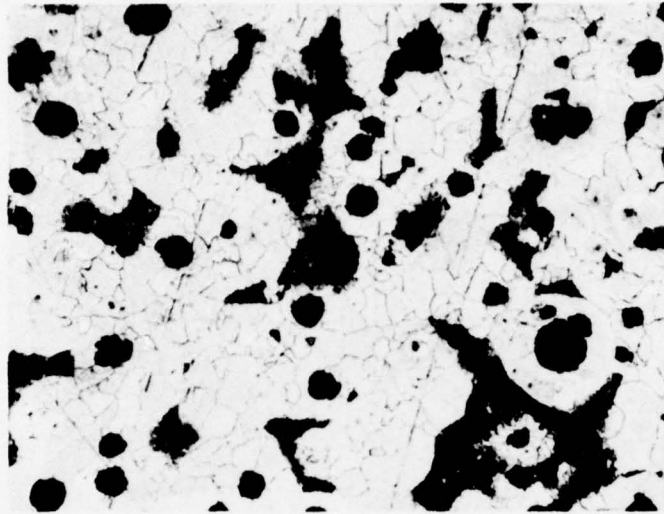

Figure 3 As-Cast Microstructure of Nodular  
Iron Heat No. 2 (1.5 Ni)

Nital Etch

100X



100X

Nital Etch

Figure 4. Photomicrograph depicting the metallurgical structure of ductile iron containing 0.75 percent Nickel which was austenitized at 1600°F for 1 hour, transferred to and held in molten salt at 1350°F for one hour, transferred to and held in molten salt at 600°F for 30 minutes and air cooled.

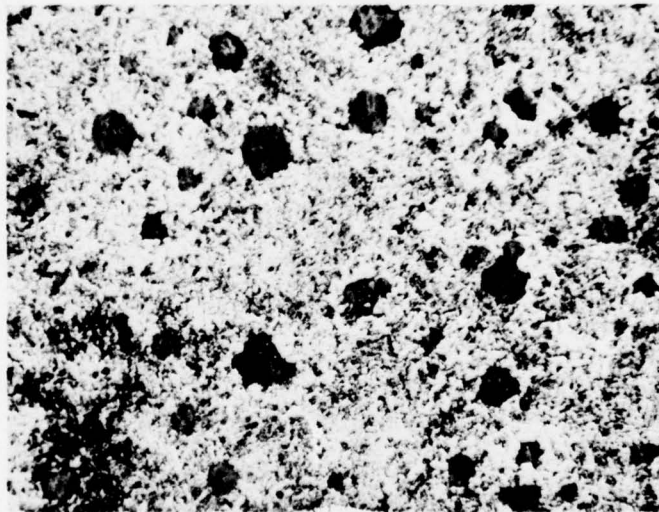

100X

Nital Etch

Figure 5. Photomicrograph depicting the metallographic structure of ductile iron containing 1.5 percent Nickel which was austenitized at 1600°F for 1 hour, transferred to and held in molten salt at 1350°F for 1 hour, transferred to and held in molten salt at 700°F for 1 hour and air cooled.

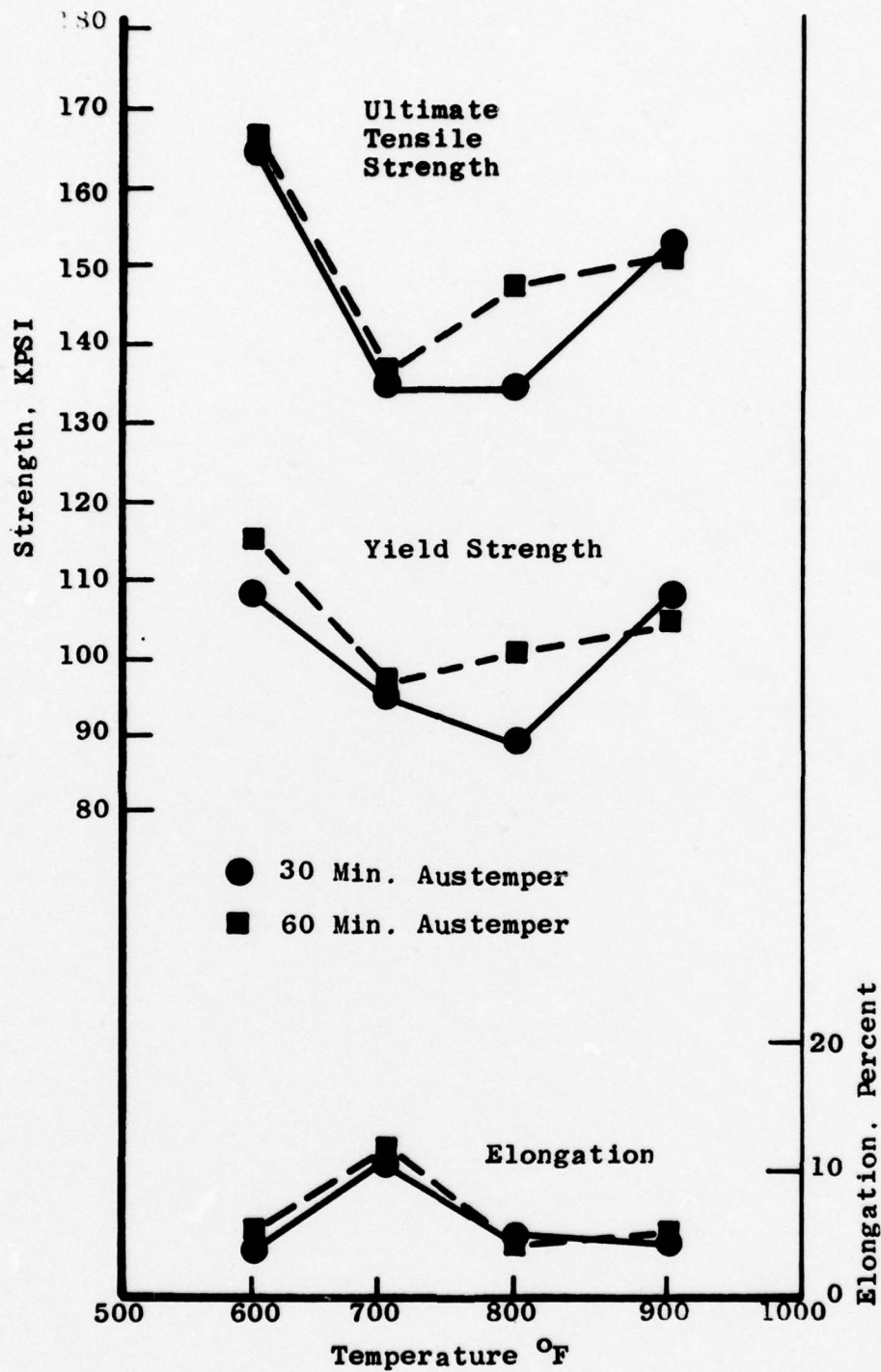
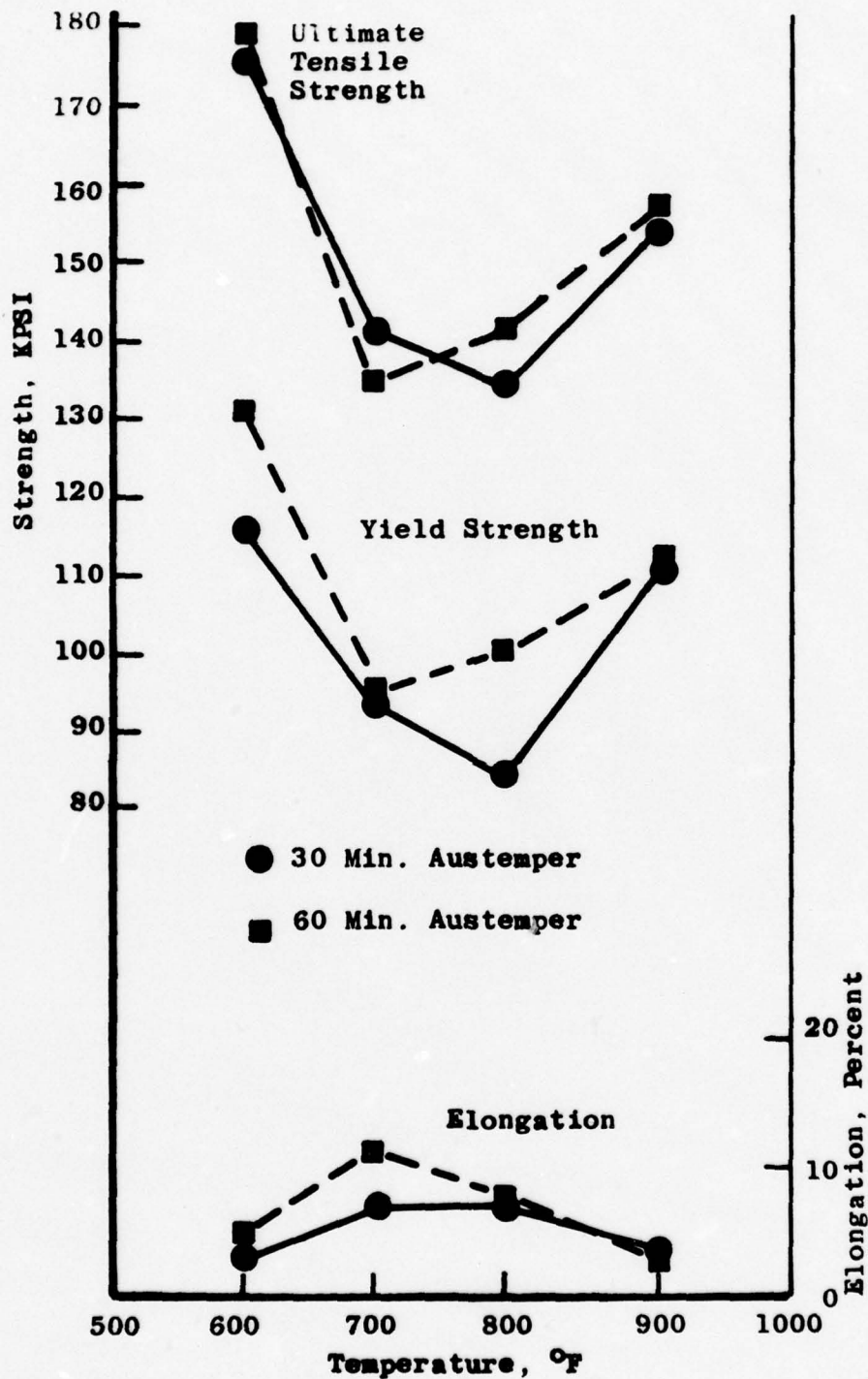

Fig. 6 Mechanical Properties of a Ductile Iron Containing 0.75 Percent Nickel, Austenitized at 1600°F and Austempered.



**Figure 7 Mechanical Properties of a Ductile Iron Containing 0.75 Percent Nickel, Austenitized at 1650°F and Austempered**

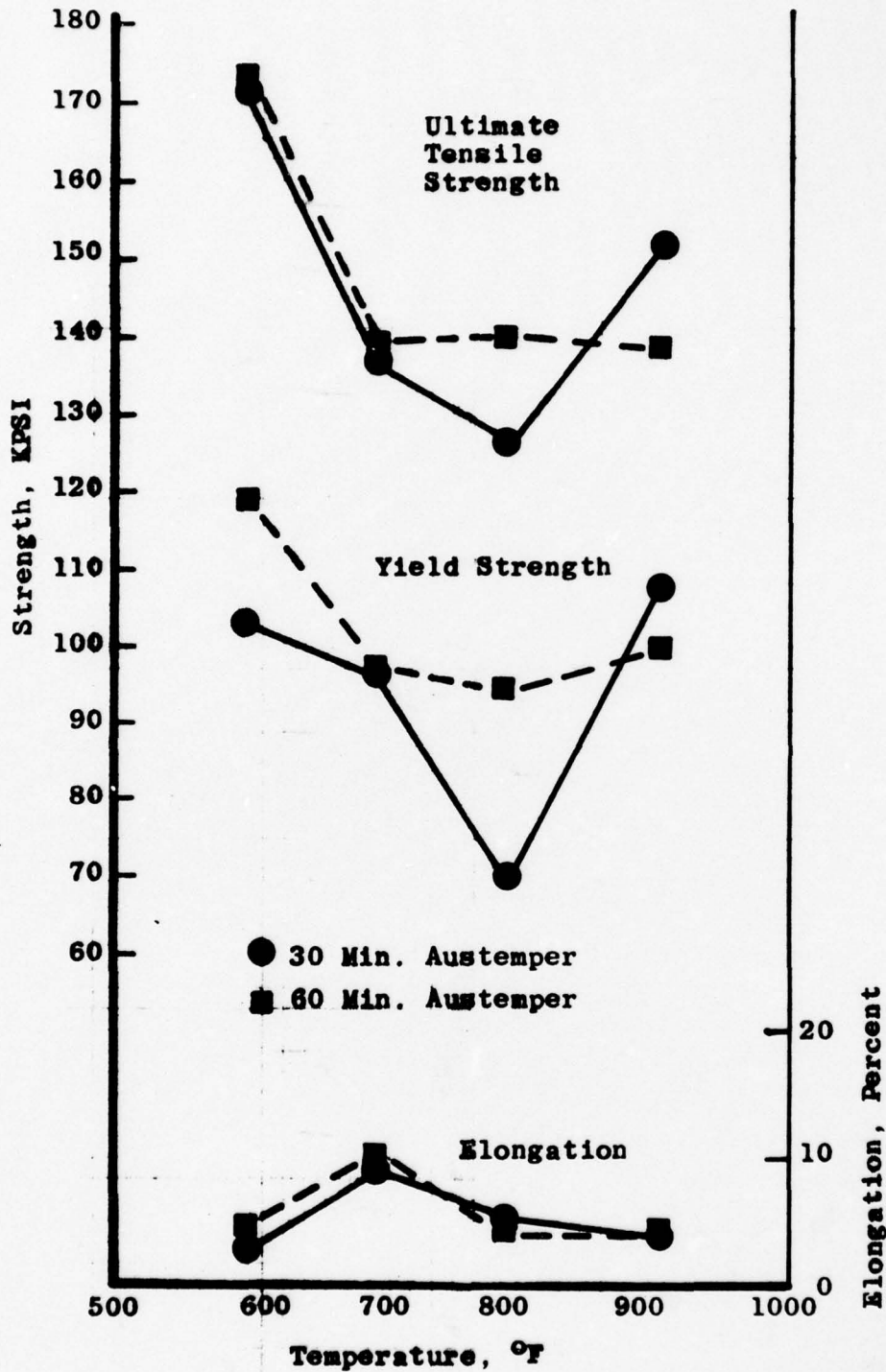
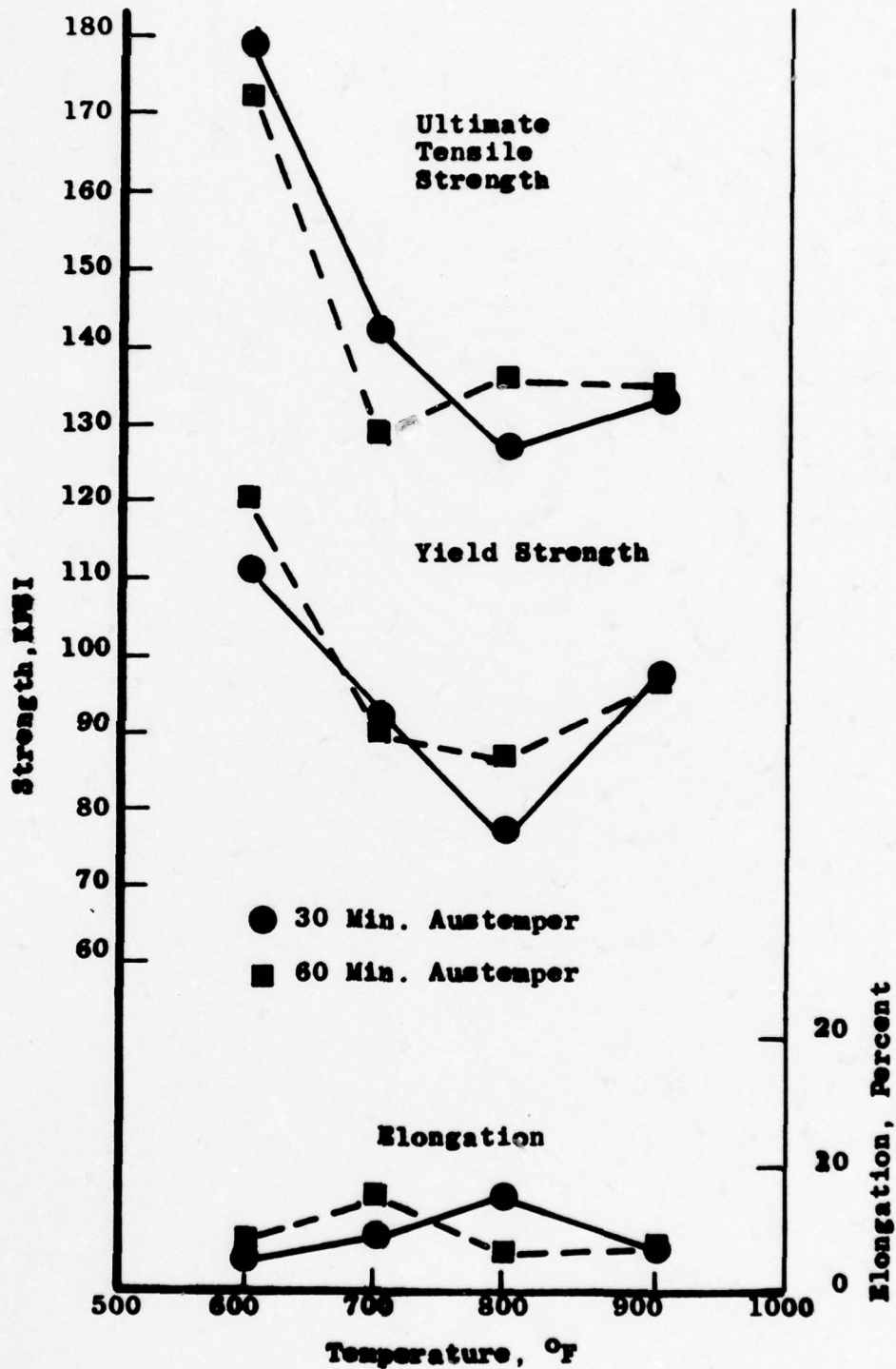

Figure 8 Mechanical Properties of a Ductile Iron Containing 1.5 Percent Nickel, Austenitized at 1600 F and Austempered



Mechanical Properties of a Ductile Iron Containing 1.5 Percent Nickel, Austempered at 1650°F and Austempered.

Figure 9

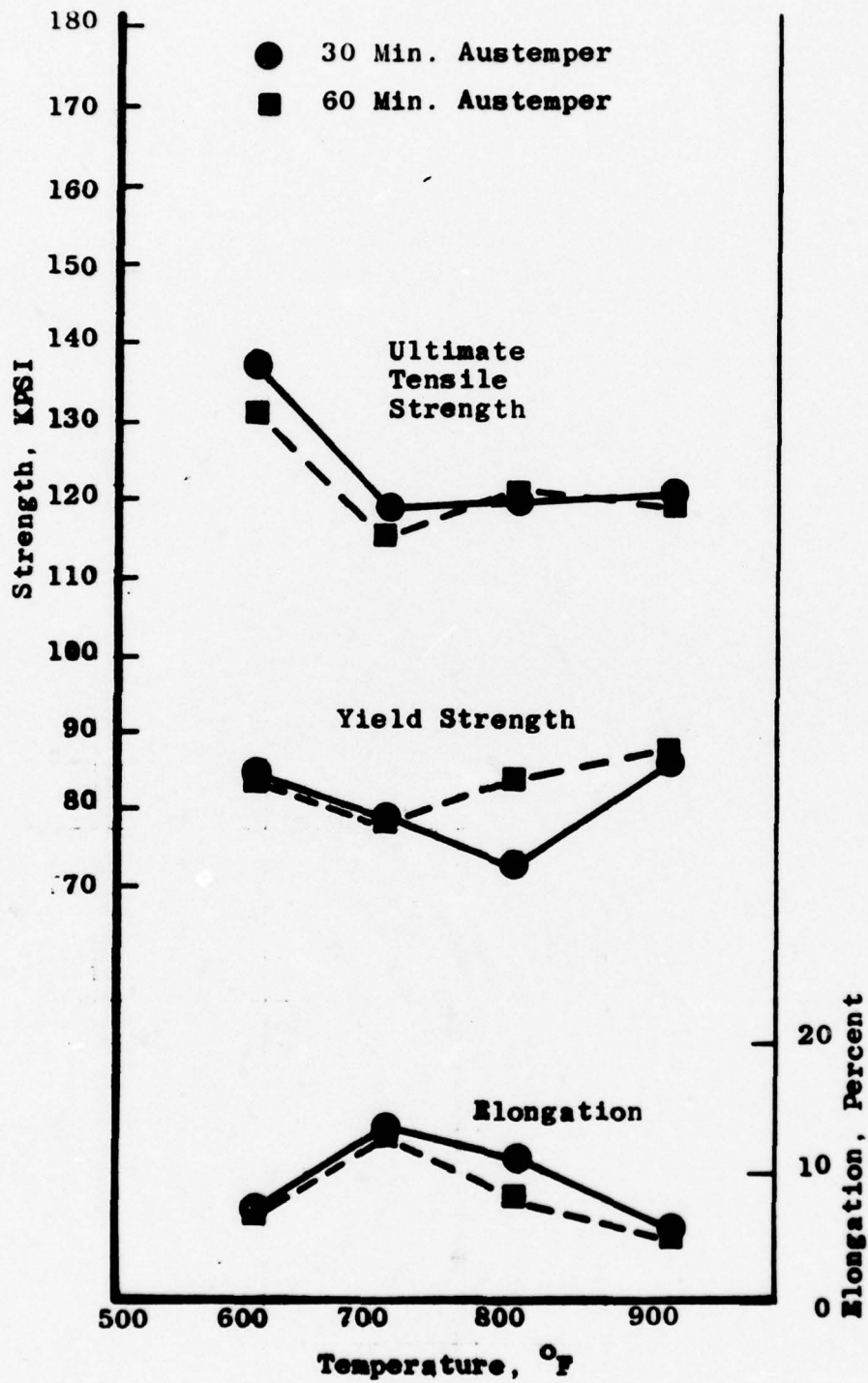

Figure 10 Mechanical Properties of a Ductile Iron Containing 1.5 Percent Nickel, Austenitized at 1600°F, Held at 1350°F For One Hour and Austempered.

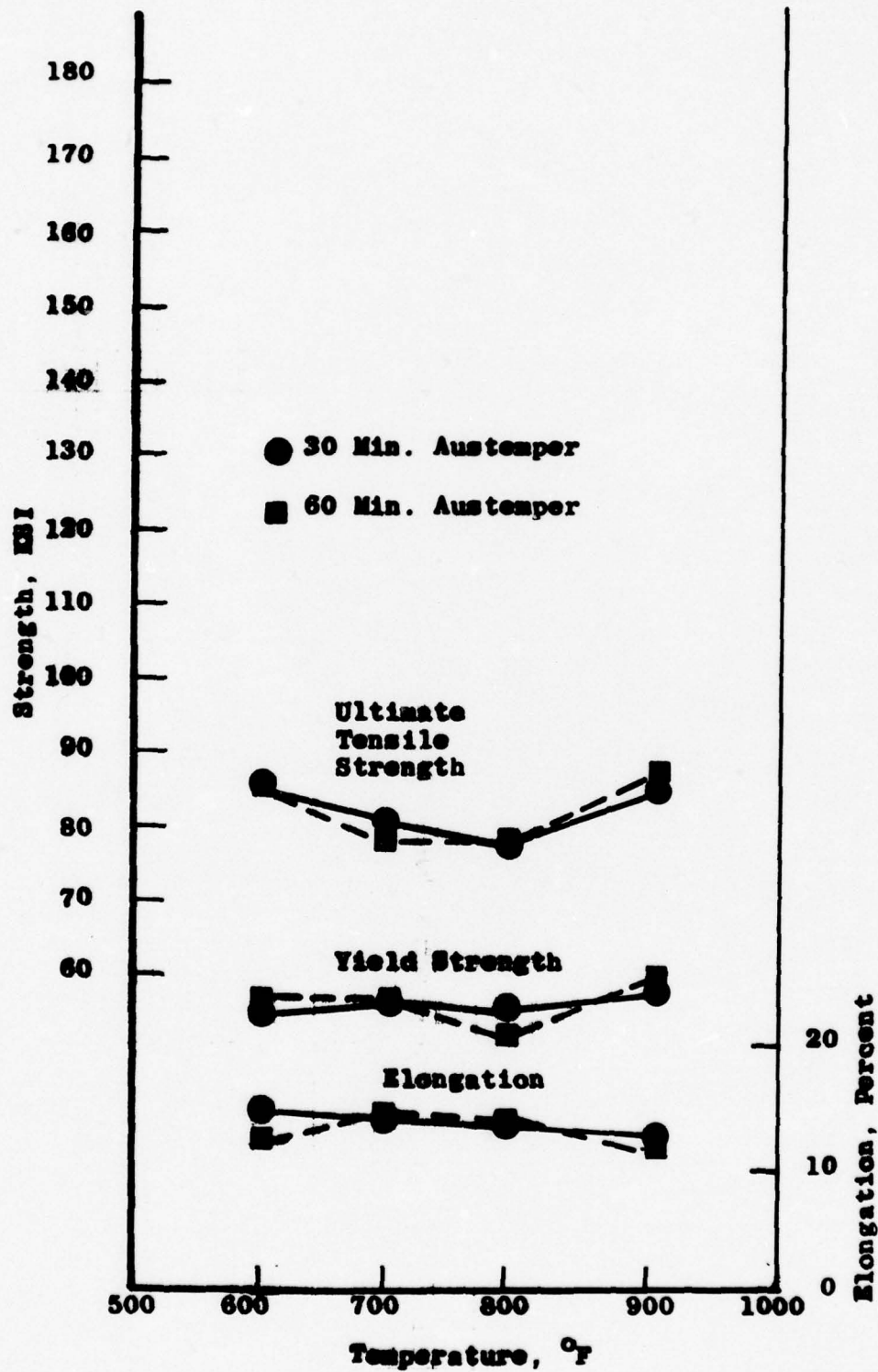

Figure 11

Mechanical Properties of Ductile Iron Containing 0.75 Percent Nickel, Austenitized at 1600°F, Held at 1350°F for One Hour and Austempered.

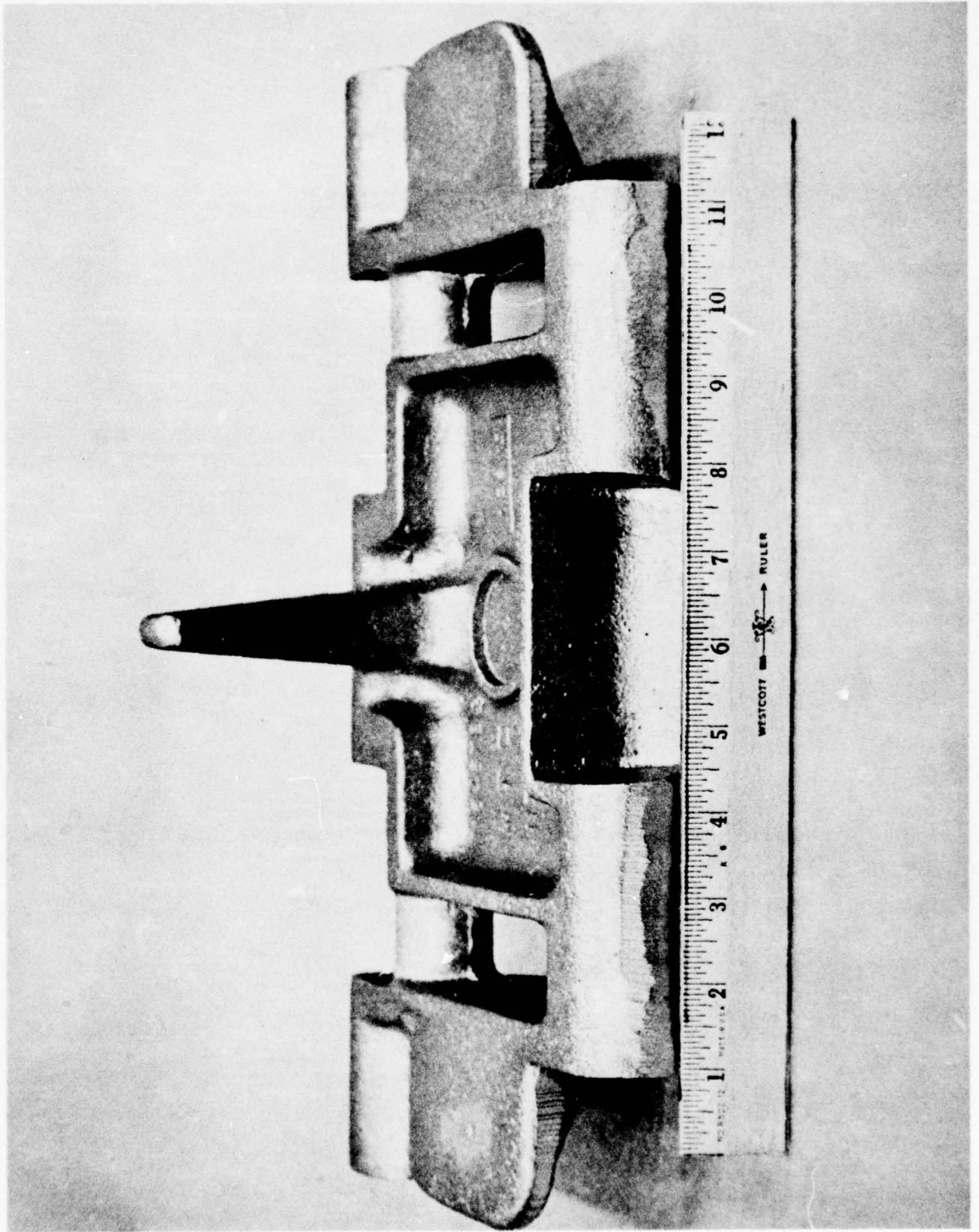

Figure 12. As-Cast Ductile Iron Track Shoe

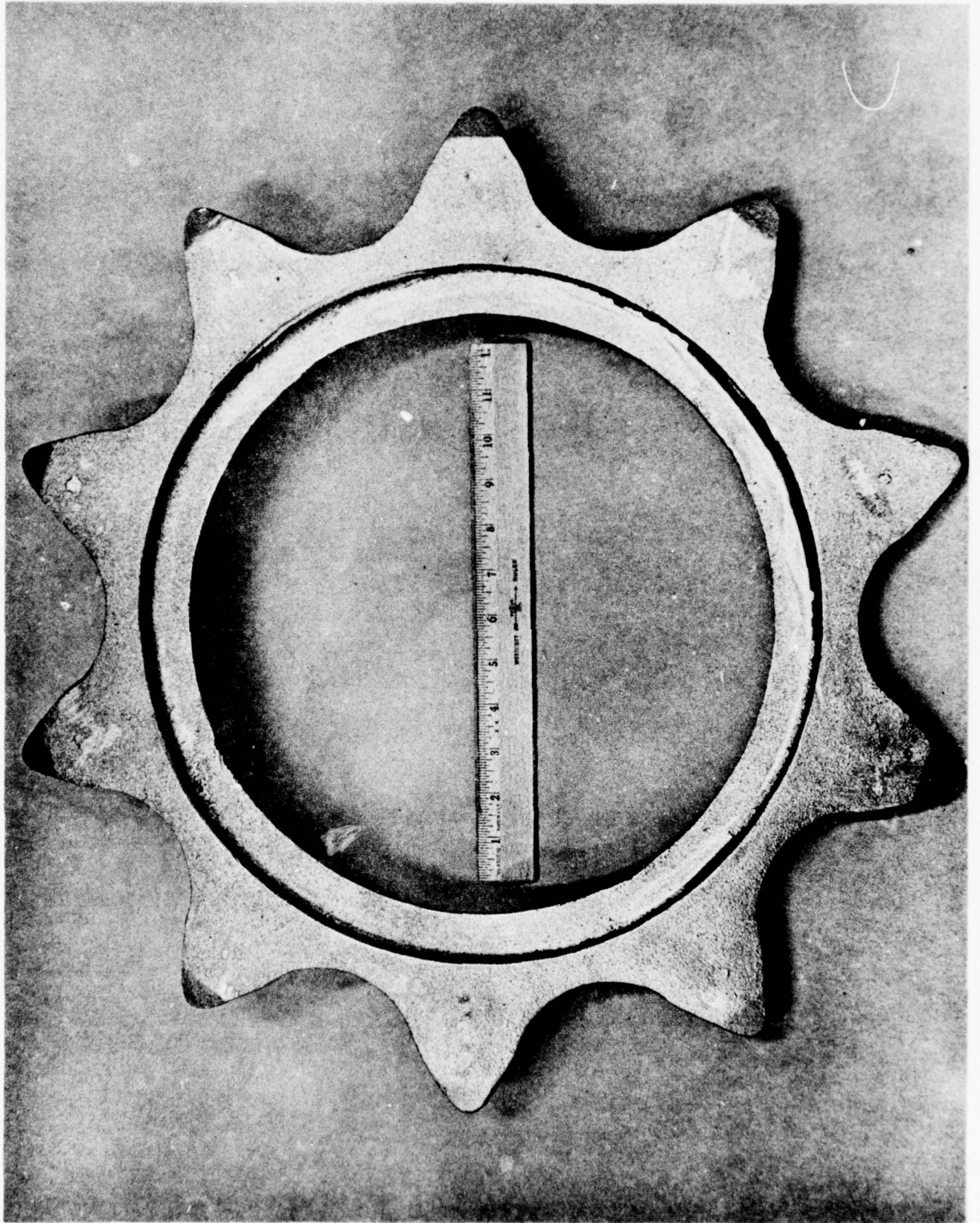

Figure 13. As-Cast Ductile Iron Sprocket

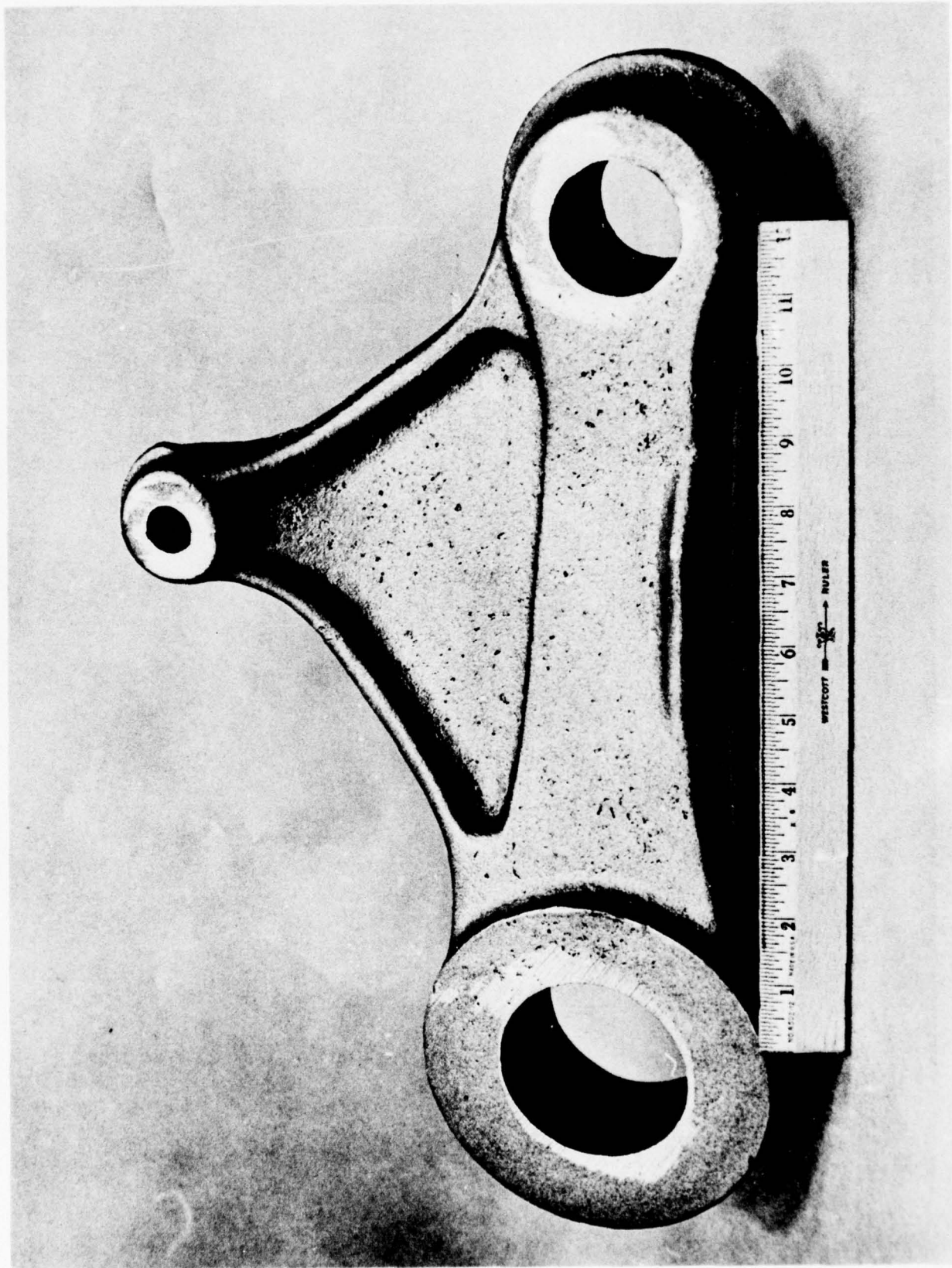

Figure 14. As-Cast Ductile Iron Suspension Arm

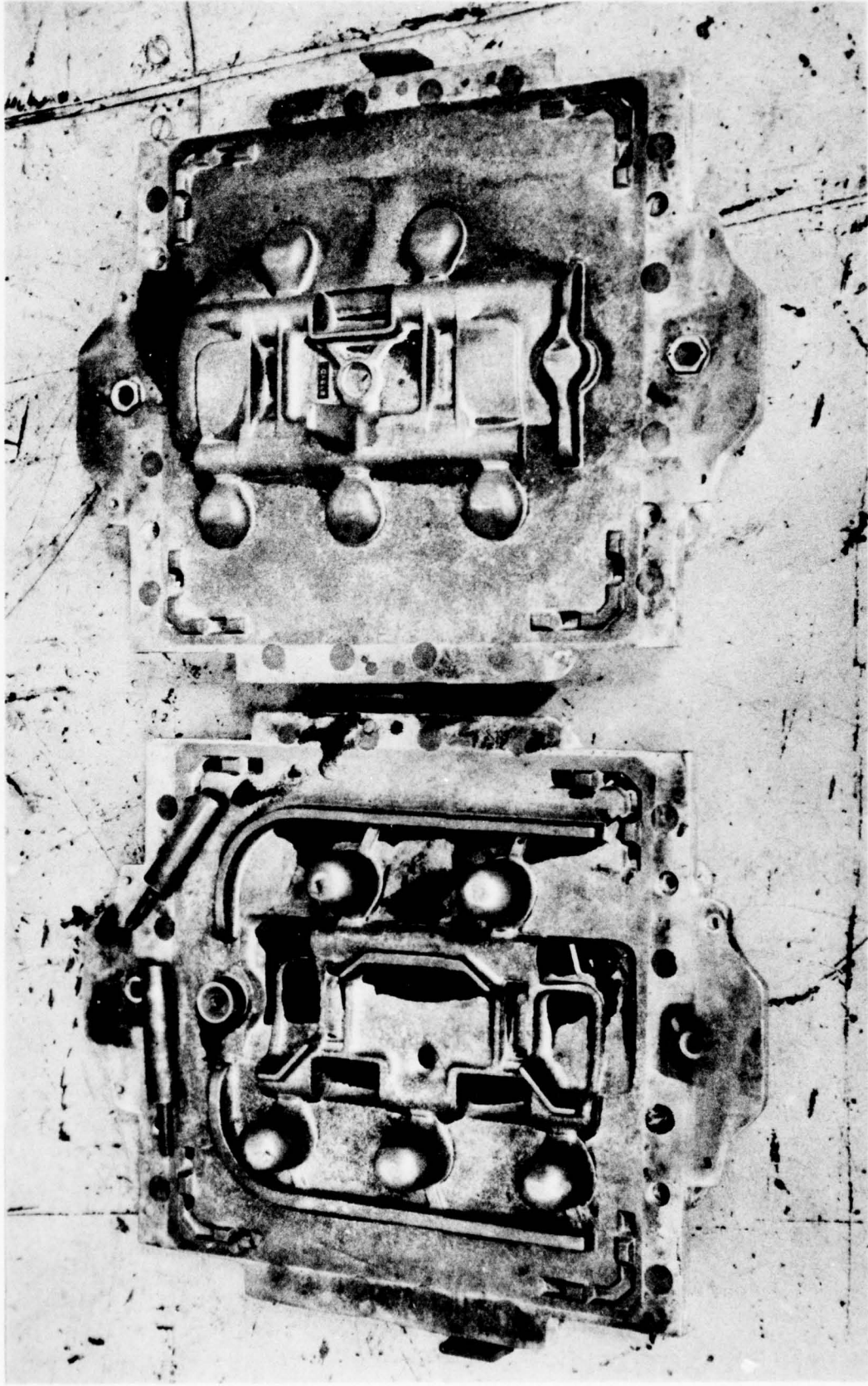

Figure 15. Pattern Mold for Track Shoe

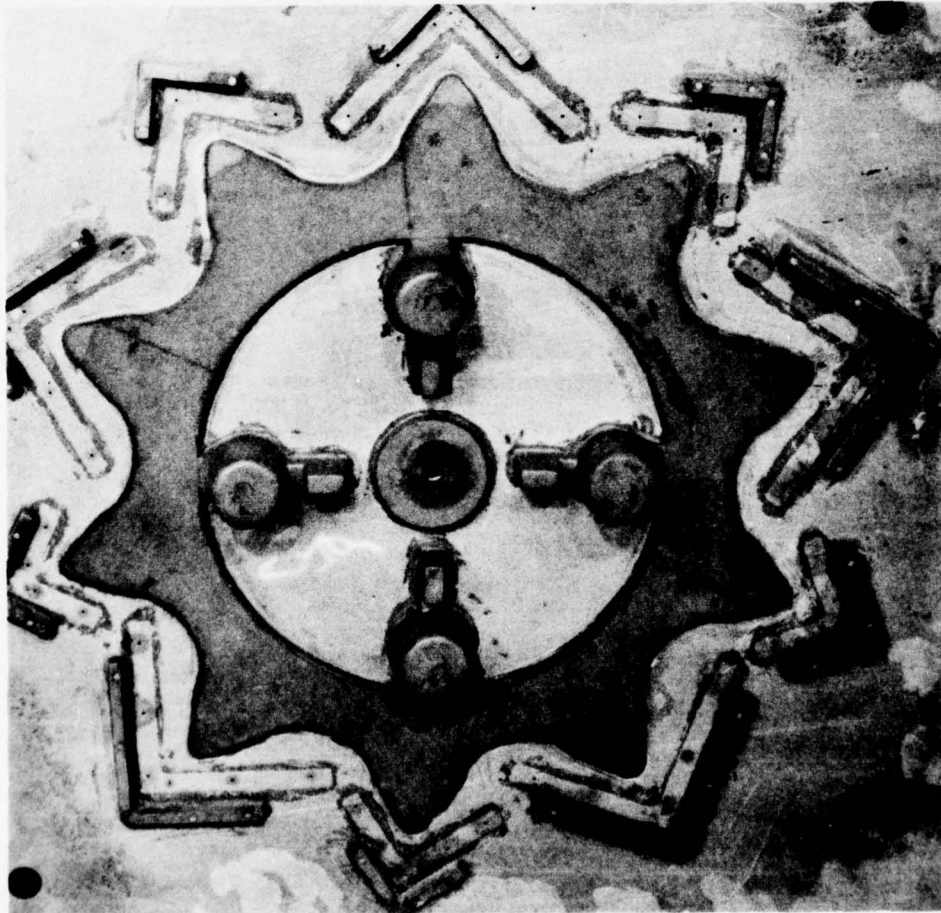
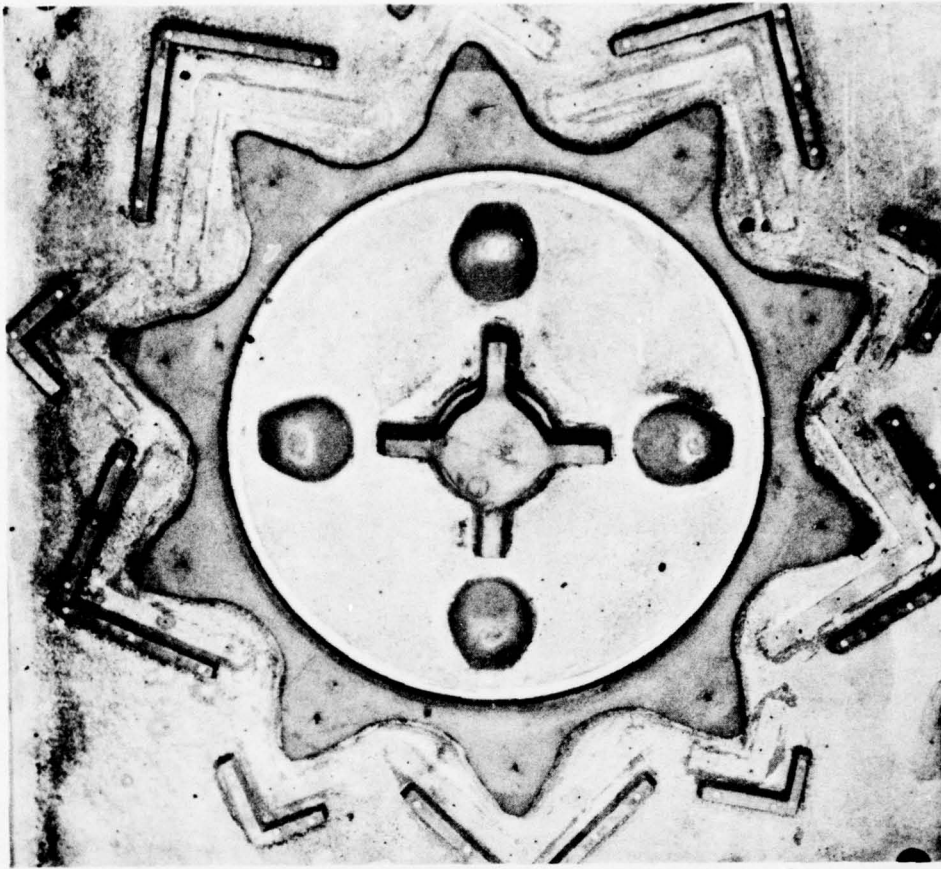

Figure 16. Pattern Mold for Sprocket

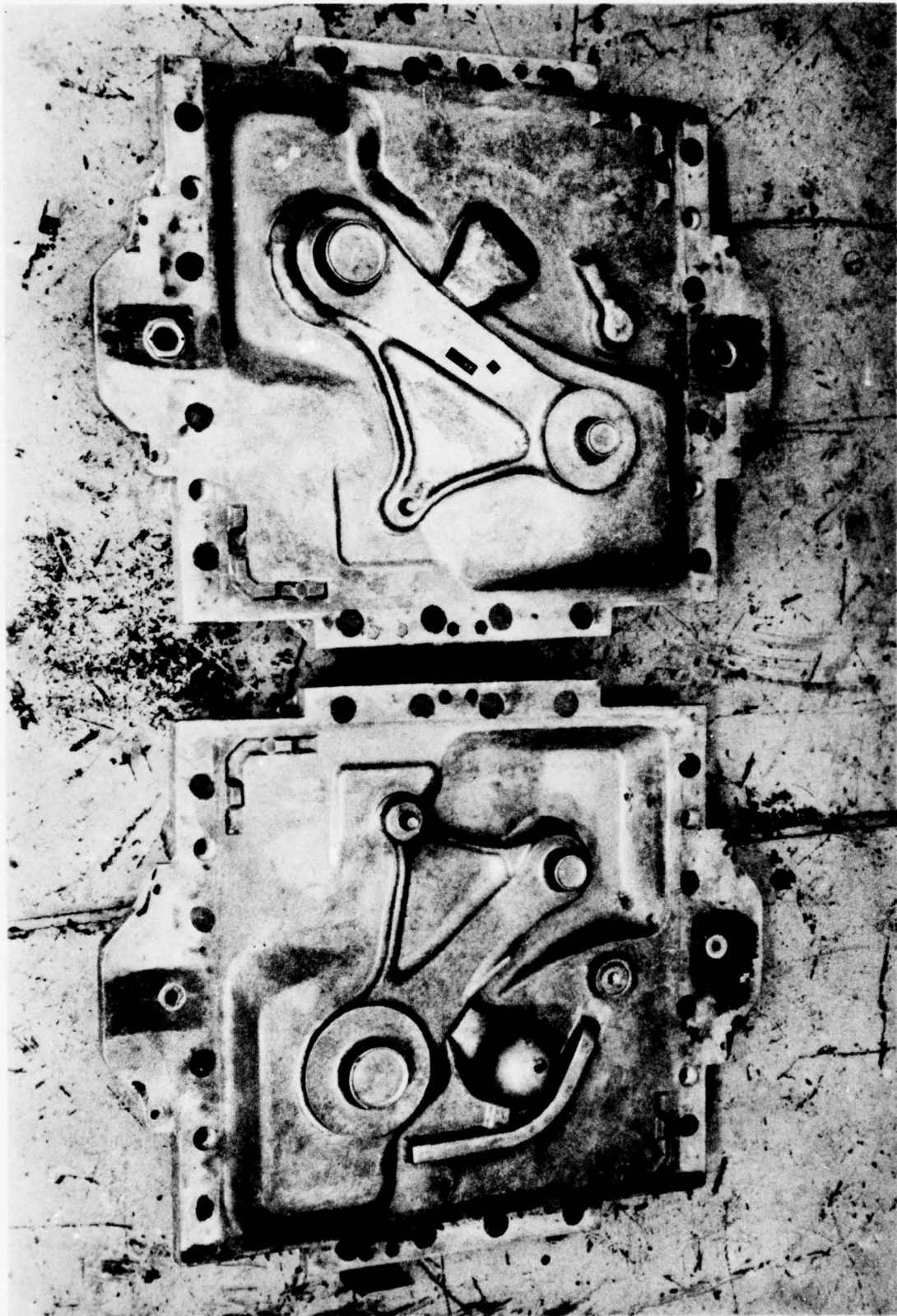

Figure 17. Pattern Mold for Road Arm

TABLE I  
CHEMICAL COMPOSITION OF DUCTILE IRON ALLOYS

<u>Heat</u>	<u>Elements, %</u>									
	<u>C</u>	<u>Mn</u>	<u>S</u>	<u>Si</u>	<u>Cr</u>	<u>Ni</u>	<u>Cu</u>	<u>Mg</u>	<u>Fe</u>	
1	3.41	0.50	0.02	2.64	0.10	0.70	0.12	0.058	Bal.	
2	3.45	0.50	0.02	2.36	0.10	1.48	0.13	0.060	Bal.	

**TABLE II**  
**AS-CAST MECHANICAL PROPERTIES OF DUCTILE IRON**

<u>Heat No.</u>	<u>Nickel Content (Percent)</u>	<u>Brinell Hardness Number</u>	<u>Ultimate Tensile Strength (PSI)</u>	<u>Yield Strength (PSI)</u>	<u>Reduction in Area (Percent)</u>	<u>Elongation (Percent)</u>
1	0.70	229	98,600	58,200	8	10.0
1	0.70	269	124,300	78,000	5	6.0
2	1.50	277	119,400	77,400	4	3.5
2	1.50	311	127,800	85,100	3	3.0

TABLE III

TENSILE PROPERTY DATA FOR DUCTILE IRON CONTAINING 0.75 PERCENT NICKEL AND AUSTENITIZED AT 1600°F FOR 1 HOUR AND AUSTEMPERED AT VARIOUS TEMPERATURES FOR EITHER 30 MINUTES OR 60 MINUTES

<u>Austemper Temp. °F</u>	<u>Time, Min.</u>	<u>UTS,psi</u>	<u>YS,psi</u>	<u>% Elong. in 2 Inch</u>
600	30	164,000	106,900	3.5
600	30	166,600	110,500	4.5
700	30	136,500	95,300	12.0
700	30	134,700	94,600	10.0
800	30	135,200	91,500	4.5
800	30	134,400	86,300	5.5
900	30	151,200	108,600	4.5
900	30	155,300	108,700	5.0
600	60	167,000	117,400	6.0
600	60	164,500	114,600	5.5
700	60	135,400	97,000	12.0
700	60	134,100	96,400	10.5
800	60	147,000	98,800	4.5
800	60	149,900	105,100	4.0
900	60	154,300	105,200	5.5
900	60	150,200	104,000	5.0

TABLE IV

TENSILE PROPERTY DATA FOR DUCTILE IRON CONTAINING 1.5 PERCENT NICKEL AND AUSTENITIZED AT 1600°F FOR 1 HOUR AND AUSTEMPERED AT VARIOUS TEMPERATURES FOR EITHER 30 MINUTES OR 60 MINUTES

<u>Austemper Temp. °F</u>	<u>Time, Min.</u>	<u>UTS, psi</u>	<u>YS, psi</u>	<u>% Elong. in 2 Inch</u>
600	30	176,000	105,700	2.5
600	30	167,000	99,300	3.0
700	30	139,300	96,000	10.0
700	30	135,100	96,800	9.0
800	30	131,200	68,800	6.0
800	30	124,600	72,200	5.5
900	30	154,400	108,100	5.0
900	30	151,500	107,900	4.0
600	60	173,400	122,200	1.5
600	60	173,300	120,800	4.5
700	60	138,100	98,300	9.0
700	60	136,200	95,300	11.5
800	60	141,700	101,900	4.5
800	60	139,800	88,800	4.0
900	60	139,600	102,200	4.0
900	60	138,000	99,700	4.0

TABLE V

TENSILE PROPERTY DATA FOR DUCTILE IRON CONTAINING 0.75 PERCENT NICKEL AND AUSTENITIZED AT 1650°F FOR 1 HOUR AND AUSTEMPERED AT VARIOUS TEMPERATURES FOR EITHER 30 MINUTES OR 60 MINUTES

<u>Austemper Temp. °F</u>	<u>Time, Min.</u>	<u>UTS, Psi</u>	<u>YS, Psi</u>	<u>% Elong. in 2 Inch.</u>
600	30	174,100	115,700	2.5
600	30	178,900	118,800	3.5
700	30	145,100	95,000	7.5
700	30	136,600	92,800	6.5
800	30	132,600	82,500	5.0
800	30	133,100	86,000	9.5
900	30	151,300	109,100	3.5
900	30	160,800	113,200	4.0
600	60	179,500	132,500	5.0
600	60	Flaw in Fracture		
700	60	135,700	94,600	11.5
700	60	134,400	94,600	11.5
800	60	141,000	100,800	3.5
800	60	142,600	101,500	4.0
900	60	154,200	108,300	3.0
900	60	161,900	114,400	4.0

TABLE VI

TENSILE PROPERTY DATA FOR DUCTILE IRON CONTAINING 1.5 PERCENT NICKEL AND AUSTENITIZED AT 1650°F FOR 1 HOUR AND AUSTEMPERED AT VARIOUS TEMPERATURES FOR EITHER 30 MINUTES OR 60 MINUTES

<u>Austemper Temp. °F</u>	<u>Time, Min.</u>	<u>UTS, psi</u>	<u>YS, psi</u>	<u>% Elong. in 2 Inch</u>
600	30	174,200	106,200	2.0
600	30	184,300	116,800	2.5
700	30	139,400	90,800	3.5
700	30	145,400	93,600	5.0
800	30	126,100	80,500	9.0
800	30	128,900	72,200	6.0
900	30	135,300	98,400	3.0
900	30	137,000	97,400	3.0
600	60	170,300	120,500	4.0
600	60	174,100	119,600	4.0
700	60	126,800	89,700	5.0
700	60	131,600	90,700	10.0
800	60	139,600	87,700	3.5
800	60	133,100	85,800	2.5
900	60	133,600	99,000	2.5
900	60	136,500	97,600	4.0

TABLE VII

TENSILE PROPERTY DATA FOR DUCTILE IRON CONTAINING 0.75 PERCENT NICKEL AND AUSTENITIZED AT 1600°F FOR 1 HOUR, TRANSFERRED TO AND HELD IN A SALT BATH AT 1350°F FOR 1 HOUR AND AUSTEMPERED AT VARIOUS TEMPERATURES FOR EITHER 30 MINUTES OR 60 MINUTES

<u>Austemper Temp. °F</u>	<u>Time, Min.</u>	<u>UTS, Psi</u>	<u>YS, Psi</u>	<u>% Elong. in 2 Inch.</u>
600	30	89,300	55,600	11.5
600	30	77,800	55,100	17.5
700	30	83,500	57,800	13.5
700	30	80,400	55,700	15.0
800	30	75,700	58,400	17.5
800	30	80,700	53,700	11.0
900	30	85,100	58,700	13.5
900	30	85,000	57,200	12.5
600	60	84,500	55,600	13.5
600	60	87,700	55,800	12.0
700	60	75,800	55,800	16.5
700	60	81,400	56,200	14.0
800	60	78,700	51,700	12.0
800	60	75,200	53,300	16.5
900	60	82,900	57,600	13.0
900	60	90,400	63,100	9.5

TABLE VIII

TENSILE PROPERTY DATA FOR DUCTILE IRON CONTAINING 1.5 PERCENT NICKEL AND AUSTENITIZED AT 1600°F FOR 1 HOUR, TRANSFERRED TO AND HELD IN A SALT BATH AT 1350°F FOR 1 HOUR AND AUSTEMPERED AT VARIOUS TEMPERATURES FOR EITHER 30 MINUTES OR 60 MINUTES

<u>Austemper Temp. °F</u>	<u>Time, Min.</u>	<u>UTS, Psi</u>	<u>YS, Psi</u>	<u>% Elong. in 2 Inch</u>
600	30	134,500	82,000	7.0
600	30	140,800	86,800	7.0
700	30	118,200	79,300	13.5
700	30			
800	30	121,300	70,000	11.0
800	30	118,200	75,400	9.5
900	30	122,000	86,400	7.0
900	30	119,100	86,600	4.5
		Flaw in Fracture		
600	60	131,400	85,200	6.5
600	60	131,900	84,200	7.5
700	60	115,500	79,200	14.0
700	60	114,400	78,600	12.5
800	60	121,800	83,500	8.0
800	60	122,700	84,300	8.0
900	60	120,100	86,500	6.5
900	60	118,900	89,400	4.0

TABLE IX

CHARPY V-NOTCH IMPACT VALUES AT SELECTED TEST TEMPERATURES FOR 0.75 PERCENT NICKEL DUCTILE CAST IRON GIVEN VARIOUS HEAT TREATMENTS

Austenitizing Temperature °F	Identification			Impact Energy Ft-Lbs			
	Temperature of Intermediate Treatment °F	Temperature of Isothermal Treatment °F	Time of Isothermal Treatment Min.	R.T. (80°F)	0°F	-20°F	-40°F
1650	N.A.	700	30	4.7	2.9	2.8	2.6
1650	N.A.	700	60	7.3	3.4	2.9	2.9
1600	1350	600	30	5.6	5.3	4.5	3.0
1600 (1.5 N1)	1350	700	60	8.1	6.1	4.5	4.2

TABLE X  
ESTIMATED COSTS TO SUPPLY SELECTED DUCTILE IRON PARTS

<u>Part No.</u>	<u>Nomenclature</u>	<u>Tooling Costs Dollars</u>	<u>Cost, Dollars</u>									
			<u>1000 Pieces</u>	<u>2000 Pieces</u>	<u>3000 Pieces</u>	<u>4000 Pieces</u>	<u>5000 Pieces</u>	<u>10,000 Pieces</u>	<u>25,000 Pieces</u>	<u>50,000 Pieces</u>		
K10875006	Road Arm	4,265	16.35	15.92	15.32	15.52	15.32	--	--	--	--	--
K11646782	Track Shoe	19,327	--	9.27	--	--	9.02	8.91	8.80	8.69	--	--
8673353	Sprocket	7,855	18.72	18.23	18.00	17.72	17.55	--	--	--	--	--

Supplied by a major producer of ductile iron castings.

TABLE XI  
MECHANICAL PROPERTIES OF VARIOUS  
DUCTILE IRON GRADES AT ROOM TEMPERATURE (80°F)

Grade	UTS Ksi	YS Ksi	Charpy Energy Ft-Lbs	KIC Ksi in*	Fatigue ** Strength Ksi	Ratio
As Cast	80	55	2.6	14.0	34	.43
Normalized	100	65	2.5	13.6	36	.36
Annealed	65	43	5.7	27.6	-	-
Isothermal .75 Ni, 1650F → 700°F (1 Hr)	135	95	7.3	34.9	62.5	.46
Isothermal 1.5 Ni, 1600F → 1350F → 700F (1 Hr) (1 Hr)	115	79	8.1	40.5	-	-

\*Calculated values using Barson-Rolfe Relation

$$\left( \frac{K_{IC}}{\sigma_y} \right)^2 = \frac{5}{\sigma_y} \left( \text{CVN} - \frac{\sigma_y}{20} \right)$$

\*\*R. R. Moore (Rotation Bending)

DISTRIBUTION LIST

<u>ADDRESSEE</u>	<u>NO. OF COPIES</u>
Commander US Army Tank-Automotive Research & Development Command Warren, MI 48090      ATTN:	
Research and Development Laboratory, DRDTA-R	1
Systems Development Division, DRDTA-RE	1
Foreign Tech-International Affairs Off, DRDTA-NF	1
Propulsion Systems Division, DRDTA-RG	1
Technical Library Branch, DRDTA-UL	3
Armor, Material Application & Tech Func, DRDTA-RKA	22
Vehicle Branch, DRDTA-JE	1
US Army Weapons Command Liaison Off, DRSWE-LCV	1
US Army Combat Developments Command Liaison Off, CDCLN-A	2
Commander US Army Tank-Automotive Materiel and Readiness Command Warren, MI 48090      ATTN:	
Chief Scientist, DRSTA-CL	1
Engineering Directorate, DRSTA-G	1
Commander US Army Materiel Development and Readiness Command ATTN: DRCRD-EA Washington, DC 22333	6
Commander US Army Natick Laboratories ATTN: Technical Library Natick, MA 01762	1
Commander Picatinny Arsenal ATTN: SMUPA-RT-S Dover, NJ 07801	1
Commander Rock Island Arsenal ATTN: SARRI-LR Rock Island, Ill 61201	1
Commander US Army Aviation Systems Command ATTN: AMSAV-ERE St. Louis, MO 63166	1

Director  
US Army Materials & Mechanics Research Center  
ATTN: AMXMR-M  
Watertown, MA 02172 1

Commander  
Letterkenny Army Depot  
ATTN: AMXLE-M  
Chambersburg, PA 17201 1

Commandant  
US Marine Corps  
ATTN: Code AX  
Washington, DC 20380 1

Commander  
Air Force Materials Laboratory  
Wright-Patterson Air Force Base  
Dayton, OH 45433 1

Defense Materials Information Center  
Battelle Memorial Institute  
505 King Avenue  
Columbus, OH 43201 1

Commander  
Harry Diamond Laboratory  
ATTN: AMXDO-PP  
Connecticut Ave & Van Ness Street  
Washington, DC 20438 1

Commander  
Seneca Army Depot  
ATTN: AMXSE-SE  
Romulus, NY 14541 1

Commander  
Tooele Army Depot  
ATTN: AMXTE-SEN  
Tooele, UT 84074 1

Commander  
Red River Army Depot  
ATTN: AMXRR-MM  
Texarkana, TX 75501 1

Commander  
US Army Missile Command  
ATTN: AMSMI-IIE  
Redstone Arsenal, AL 35809 1

Commander  
Defense Documentation Center  
Cameron Station  
Alexandria, VA 22314 12

Office of Chief of Research & Development  
Department of the Army  
ATTN: CRDCM  
Washington, DC 20310 1

Quality Evaluation Laboratory  
Naval Ammunition Depot  
ATTN: Code 3031, Dr. Robert Klausmeier  
Crane, IN 47522 1

Commander  
Frankford Arsenal  
ATTN: SMUFA-L7000  
Philadelphia, PA 19137 1

Commander  
Pueblo Army Depot  
ATTN: AMXPU-ME  
Pueblo, CO 81001 1

Director  
US Army Production Equipment Agency  
ATTN: AMXPE-MT  
Rock Island, IL 61201 10

Commander  
US Army Combat Developments Command  
Combat Arms Group  
ATTN: Materiel Division  
Ft. Leavenworth, KS 66027

Commander  
US Army Combat Developments Command  
Combat Service Support Group  
ATTN: Materiel Division  
Ft. Leavenworth, KS 66027 1

Commander  
US Army Combat Developments Command  
Combat Service Support Group  
ATTN: Materiel Division  
Ft. Lee, VA 23801 1

Commander  
Watervliet Arsenal  
ATTN: SARWV-PPP-WP, LAJ  
Watervliet, NY 12189 2

Commander  
Army Research Office (Durham)  
Box CM, Duke Station  
Durham, NC 27706 1

Commander  
Blue Grass Army Depot  
ATTN: AMXLX-SE-1  
Lexington, KY 40507 1

Commander  
New Cumberland Army Depot  
ATTN: AMXNC-SM, MT-E  
New Cumberland, PA 17070 2

Air Airce Armament Laboratory  
ATTN: Mr. A. Lopez, DLGZ  
Product Assurance Division  
Eglin AFB, FL 32542 1

Air Force Materials Laboratory  
ATTN: Mr. L. Clark, AFML/LTM  
Manufacturing Technology Division  
Wright-Patterson AFB, OH 45433 1

Commander  
Materials Research Laboratory  
Ft. Belvoir, VA 22060 1

Commander  
US Army Test & Evaluation Command  
ATTN: AMSTE-BB  
AMSTE-TA  
Aberdeen Proving Ground, MD 21005 1  
1

Commander  
Anniston Army Depot  
ATTN: AMXAN-DM  
Anniston, AL 36201

1

Commander  
Atlanta Army Depot  
ATTN: AMXAT-MP  
Forest Park, GA 30050

1

Commander  
UW Army Troop Support Command  
ATTN: AMSTS-PLC  
4300 Goodfellow Blvd.  
St. Louis, MO 63210

1

Commander  
US Army Electronics Command  
ATTN: AMSEL-PP/P-IM  
225 S. 18th Street  
Philadelphia, PA 19103

1

Director  
Naval Research Laboratory  
Anacostia Station  
ATTN: Technical Information Center  
Washington, DC 20390

1

Unclassified

SECURITY CLASSIFICATION OF THIS PAGE (When Data Entered)

<b>(19) (TACOM) REPORT DOCUMENTATION PAGE</b>		<b>READ INSTRUCTIONS BEFORE COMPLETING FORM</b>
<b>1. REPORT NUMBER</b> TR-12167	<b>2. DOWNT ACCESSION NO.</b>	<b>3. RECIPIENT'S CATALOG NUMBER</b>
<b>4. TITLE (and Subtitle)</b> Isothermal Heat Treatment for High Strength Ductile Iron Castings.		<b>5. TYPE OF REPORT &amp; PERIOD COVERED</b> Final 6/27/73 - 11/17/75
<b>7. AUTHOR(s)</b> Clarence J. Carter, Robert E. Wahlstrom Raymond A. Cellitti		<b>6. PERFORMING ORG. REPORT NUMBER</b>
<b>9. PERFORMING ORGANIZATION NAME AND ADDRESS</b> International Harvester Company Manufacturing Services Hinsdale, Illinois		<b>8. CONTRACT OR GRANT NUMBER(s)</b> DAAE07-73-C-0308 new
<b>11. CONTROLLING OFFICE NAME AND ADDRESS</b> U.S. Army Tank - Automotive Research & Development Command Warren, Michigan 48090		<b>10. PROGRAM ELEMENT, PROJECT, TASK AREA &amp; WORK UNIT NUMBERS</b> 12/46p.
<b>14. MONITORING AGENCY NAME &amp; ADDRESS (if different from Controlling Office)</b>		<b>12. REPORT DATE</b> 11 Jun 76
		<b>13. NUMBER OF PAGES</b> 37
		<b>15. SECURITY CLASS. (of this report)</b> Unclassified
		<b>15a. DECLASSIFICATION/DOWNGRADING SCHEDULE</b>
<b>16. DISTRIBUTION STATEMENT (of this Report)</b> Distribution of this document is unlimited		
<b>17. DISTRIBUTION STATEMENT (of the abstract entered in Block 20, if different from Report)</b>		
<b>18. SUPPLEMENTARY NOTES</b>		
<b>19. KEY WORDS (Continue on reverse side if necessary and identify by block number)</b> Bainitic Ductile Iron Heat Treatment V-Notch Impact Tensile Properties Fatigue Strength		
<b>20. ABSTRACT (Continue on reverse side if necessary and identify by block number)</b> Austempered ductile iron containing nickel was investigated as an economical substitute for alloy steel forgings currently used as critical components in armored vehicles (M113 personnel carrier). An optimum austemper treatment evolved which resulted in a cast ductile iron which delivered 135 ksi ultimate, 97 ksi yield strength and 11% elongation. Low temperature (-40F) impact toughness was 3 ft-lbs and rotational bending fatigue strength was 62.5 ksi at room temperature. A quantity of select components namely suspension arm, sprocket and track shoe were cast, heat treated and finished machined to demonstrate the applicability of the manufacturing process as well as the service performance of these cast components when subjected to field testing under extreme environmental conditions.		

DD FORM 1 JAN 73 1473

EDITION OF 1 NOV 65 IS OBSOLETE

406 588

SECURITY CLASSIFICATION OF THIS PAGE (When Data Entered)

Unclassified

mt