

AD-A035 435

COMMUNICATIONS RESEARCH CENTRE OTTAWA (ONTARIO)
THE CCS-280 OPTICAL-FIBER LINK TASK. (U)
DEC 76 E H HARA, H C FRAYN, A WATANABE
CRC-1296

F/G 20/6

UNCLASSIFIED

DRB-TELS-40

NL

| of |
ADA035435



END

DATE
FILMED
3 - 77

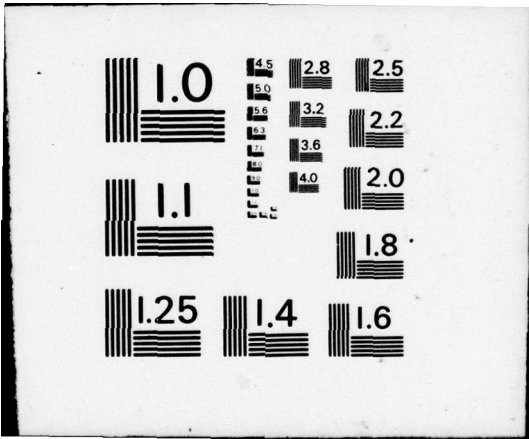

NTIS REPRODUCTION
BY PERMISSION OF
INFORMATION CANADA

3

J

Communications Research Centre

AD A035435

THE CCS-280 OPTICAL-FIBER LINK TASK FINAL REPORT

by

Elmer H. Hara, H. Claire Frayn and Akira Watanabe

DDC
RECEIVED
FEB 10 1977
B

DEPARTMENT OF COMMUNICATIONS
MINISTÈRE DES COMMUNICATIONS

CRC REPORT NO. 1296

This work was sponsored by the Department of National Defence, Research and Development Branch under Project No. 28-03-24, Task No. PCN-35C19.

CANADA

DISTRIBUTION STATEMENT A
Approved for public release;
Distribution Unlimited

OTTAWA, DECEMBER 1976

COMMUNICATIONS RESEARCH CENTRE

DEPARTMENT OF COMMUNICATIONS
CANADA

⑨ Final Rept.

⑧

THE CCS-280 OPTICAL-FIBER LINK TASK •
FINAL REPORT

by

⑩

Elmer H. Hara, H. Claire Frayn and Akira Watanabe

(Technology and Systems Branch)

⑪ Dec 76

⑭ CRC-1296

⑫ 34p.

⑮ DRB

⑰ TELS-40

ACCESSION for	
NTIS	White Section <input checked="" type="checkbox"/>
DDC	Soft Section <input type="checkbox"/>
UNANNOUNCED	<input type="checkbox"/>
JUSTIFICATION	
BY	
DISTRIBUTION/AVAILABILITY CODES	
SER.	Acq. and/or SPECIAL
A	

CRC REPORT NO. 1296
TELS REPORT NO. 40

Received November 1976
Published December 1976
OTTAWA

This work was sponsored by the Department of National Defence, Research and Development Branch under Project No. 28-03-24, Task No. PCN-35C19.

CAUTION

The use of this information is permitted subject to recognition of proprietary and patent rights.

404957

VB

TABLE OF CONTENTS

ABSTRACT.	1
1. INTRODUCTION.	1
2. FORMULATION OF THE OPTICAL-LINK TASK.	2
3. DESIGN AND IMPLEMENTATION OF THE OPTICAL-FIBER LINK	5
4. INSTALLATION AND TESTING OF THE OPTICAL LINK AND COMPONENTS	16
5. CONCLUSIONS	17
6. ACKNOWLEDGEMENT	17
7. REFERENCES.	18
APPENDIX A - The CCS-280 Cable-Breakage Problem	19
APPENDIX B - Advantages of Optical-Fiber Waveguides	20
APPENDIX C - Task Description	23
APPENDIX D - Acceptance Tests for the Optoelectronic Plug-In Units.	25
APPENDIX E - Testing of the Multiplexing-Demultiplexing System and Optoelectronic Units	28
APPENDIX F - Acceptance Tests for the Optical Link.	31

THE CCS-280 OPTICAL-FIBER LINK TASK
FINAL REPORT

by

Elmer H. Hara, H. Claire Frayn and Akira Watanabe

ABSTRACT

✓ The development of an experimental optical-fiber link for the Command and Control System 280 (CCS-280) of the DDH-280 Destroyer Escorts of the Canadian Forces is described. The objective of the task was to demonstrate the application of optical-fiber transmission links in a land-based CCS-280, and thereby alert and inform the armed forces of the advantages of optical-communications technology in military systems. The Task was planned and managed by the Department of Communications on behalf of the Department of National Defence, while the design and implementation of the optical link were accomplished through industrial contracts. All test conditions set by the Directorate of Maritime Combat Systems were satisfied by the experimental optical-fiber link.

1. INTRODUCTION

The Department of Communications (DOC) was approached early in 1973 by the Action Information Systems Section of the Directorate of Maritime Combat Systems (DMCS7) of the Department of National Defence (DND) with regard to a breakage problem in the cable system for the Command and Control System 280 (CCS-280). Since the cables carrying digital signals were large and stiff, movement of the chassis during maintenance placed stress on the cable, with the result that connector pins within the plugs were broken on a number of occasions. Such failures could result in a severe reduction of the combat

readiness of the DDH-280 class destroyer escorts. CRC was consulted on possible solutions to the problem, and several conventional remedies were recommended (c.f. Appendix A).

Also, DMCS7 indicated a desire to demonstrate the application of optical-fiber links as alternatives to coaxial-cable systems, particularly in action data systems such as the CCS-280, in order to alert and inform the armed forces of the advantages of optical-communications technology in military systems. Demonstration of the faithful transmission of complex digital signals, ranging from near DC to megabit-per-second pulse rates with fast rise and fall times, would demonstrate the feasibility of employing optical links in such military applications.

Since the coaxial cable systems of the CCS-280 currently under operation do not experience problems with electro-magnetic interference, crosstalk and ground loops, the use of optical-fiber cables in this system would not demonstrate their advantages (c.f. Appendix B) to the fullest. Nevertheless, the importance of demonstrating the operation of optical-fiber links in military applications was recognized, and the CCS-280 Optical-Link Task was formally approved by DOC and DND in October 1973. The Task was completed in January 1976 with the installation and successful operation of the optical link in the CCS-280 located at the Canadian Forces Fleet School. This report summarizes the activities on the Task and also contains a technical description of the experimental system.

2. FORMULATION OF THE OPTICAL-LINK TASK

The objective of the Task was to demonstrate the application of optical-fiber transmission links in a combat action data system. Demonstration on a land-based system was deemed to be satisfactory by DND, in order to avoid the complications of scheduling and carrying out shipboard tests. It was therefore decided to install and test the optical link in the CCS-280 located at the Canadian Forces Fleet School in Halifax. The duration of the Task was set at 29 months and the Task budget was \$195,000.00. The Task Description is summarized in Appendix C.

The Task was carried out at the Communications Research Centre (CRC) by the Optical Systems Research Program of the Directorate of Communications Techniques and Equipments Research. CRC was responsible for overall Task planning and management, while the design, construction, installation and testing of the optical link were accomplished through industrial contracts that were monitored by CRC. Figure 1 shows the management structure for the Task. Two government departments, DND and DOC, and two industrial firms, Bell-Northern Research Ltd. (BNR) and Litton Systems (Canada) Ltd. (LSL) were the principal parties involved in the Task.

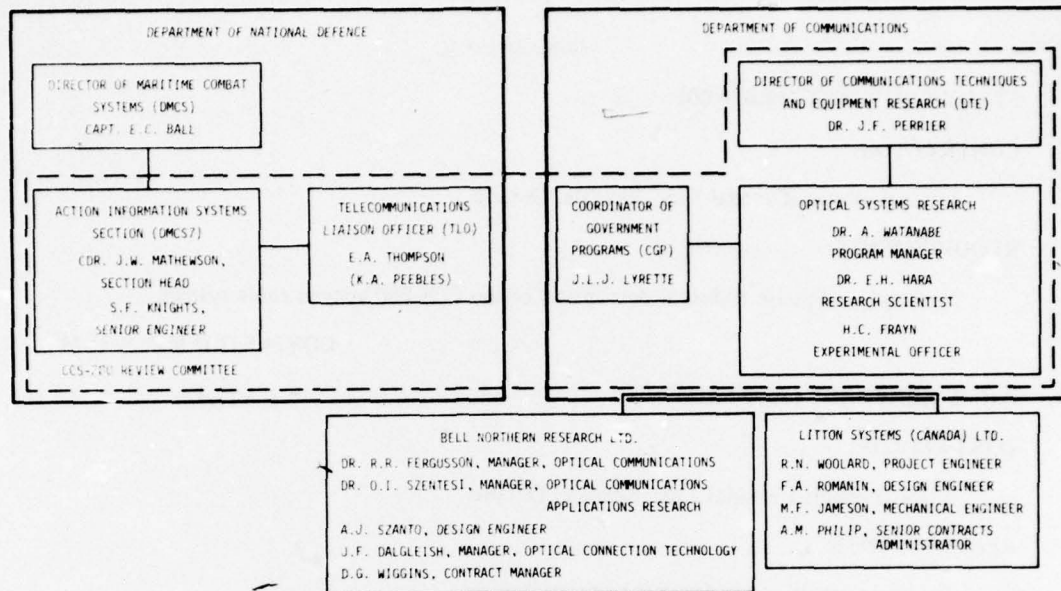

Figure 1. Management Structure of the Task.

Department of Supply and Services provided supervision on the details of contract performance. The CCS-280 Review Committee met at regular intervals in order to review progress on the Task and to expedite the flow of information through the managerial chain.

Three contracts were issued, a Study Contract, A Prime Contract, and an Optoelectronic Components contract. Table 1 summarizes the three contracts[†] for the Task. The Study Contract was issued to obtain a concise technical description of the CCS-280 coaxial cable system^{††}. The description was used to provide a guide in the design of the optical-fiber link for the bidders on the prime contract.

A general request for proposals on the prime contract to design, construct and install the optical-fiber link was first distributed to companies indicating an interest in the Task. The proposals were then evaluated according to a point-score system devised by the Department of Supply and Services in consultation with CRC. As a result, Litton Systems (Canada) Ltd. was selected as the prime contractor on the basis of technical design, cost and capability. Since the contract was basically a development contract, no specifications were defined for the physical dimensions of the component units of the optical link.

[†] Copies of the contracts are filed at Central Registry, CRC under the title "Contract Documentation: Optical Link for the CCS-280", file No. 6040-5-1. They may be viewed on a need-to-know basis.

^{††} A summary of the CCS-280 Cable System is contained in "Data Package Regarding CCS-280 Data Cables and Signal Characteristics", a report prepared by Litton Systems (Canada) Limited in March 1974. This document is available on a need-to-know basis from DND.

TABLE 1

Task Contracts

1. STUDY CONTRACT (\$1,070.00)

CONTRACTOR:

Litton Systems (Canada) Ltd., Rexdale, Ontario.

REQUIREMENTS:

To supply a concise technical description of the CCS-280 coaxial cable system.

COMPLETED March, 1974

2. PRIME CONTRACT (\$97,500.00)

CONTRACTOR:

Litton Systems (Canada) Ltd., Rexdale, Ontario.

REQUIREMENTS:

To design, construct and test the optical link by

- i) designing and fabricating the multiplexing and demultiplexing units,
- ii) testing and debugging the multiplexing and demultiplexing units through a hardwire link,
- iii) integrating the optoelectronic units into the system,
- iv) testing and debugging the optical link,
- v) installing, testing and debugging the optical link at the Canadian Forces Fleet School in Halifax and
- vi) providing technical assistance during the Acceptance Tests.

COMPLETED January, 1976

3. OPTOELECTRONIC COMPONENTS CONTRACT (\$63,000.00)

CONTRACTOR:

Bell-Northern Research Ltd., Ottawa, Ontario

REQUIREMENTS:

To design, construct and test optoelectronic components consisting of 32 sets of

- i) transmitter units which contain,
 - a) LED drivers with TTL compatible input,
 - b) Burrus-type LEDs,
 - c) fiber couplers and
- ii) receiver units which contain,
 - a) fiber couplers,
 - b) PIN photodiodes and
 - c) post-detection amplifiers with TTL compatible output, and

to design, construct and test an optical fiber cable 4m in length containing a minimum of 31 transmission channels.

COMPLETED October, 1975

The final Acceptance Authority was assigned to qualified observers appointed by DMCS7, who were the sponsors of the Task. Full cooperation was received from LSL during the course of the contract and their experience with the existing CCS-280 proved to be invaluable in bringing the task to a successful conclusion.

Bell-Northern Research Ltd. was selected as the supplier of the optoelectronic components based on the results of competitive bidding. The extensive experience of BNR in the development of optical fibers, fiber couplers, light-emitting diodes (LED) and optoelectronic circuitry proved to be invaluable. In particular, their development work in high-brightness Burrus-type LEDs and fiber couplers was probably the most advanced at the time the contract was signed.

Despite the developmental nature of the optoelectronic components, a firm-price contract of \$63,000.00 was agreed upon. Aside from the cost factor, extended negotiations were required on the length of the guarantee period and delivery dates.

Since the optoelectronic components were to be developed from experimental devices, detailed dimensional specifications were not imposed in order not to hinder application of good electronic engineering practices. Only electronic performance specifications given by the prime contractor, Litton Systems (Canada) Ltd., and the optical cable length (4 m) were stated in the contract. The design of the optoelectronic units was revised several times upon consultation with LSL and the Design Authority after the contract was signed. The cooperation between BNR and LSL was excellent throughout the task.

3. DESIGN AND IMPLEMENTATION OF THE OPTICAL-FIBER LINK

The BNR design, based on the single-fiber-per-channel approach, was chosen over the conventional bundled-fiber designs because it would provide a smaller cable, and BNR was known to possess the full technical capability to develop the components for the single-fiber design. Also, it was felt that the single-fiber design would become the accepted industry standard in the future.

A block diagram of the CCS-280 is shown in Figure 2. The situation display consoles (SDC) are connected to the computer through the electronic marker generator. Each SDC (c.f. Figure 3) has a large cathode ray tube (CRT) that displays the combat situation and a small CRT that displays file information. An operator monitors the displays and provides input to the central computer for action. An analogue and digital signal-cable system interconnects the SDCs in "daisy-chain" fashion. The multiplicity of connections to an SDC is clearly seen in Figure 4; each SDC has attached to it an input and an output digital plug along with analogue and other cables. Each digital plug combines two 78-pin connectors, and terminates two 1.25" diameter cables comprising a total of 70 coaxial cables and 14 copper wires. A close-up of the input and output digital plugs is shown in Figure 5. The optical link was placed in between SDCs No. 5 and No. 6 in order to allow ready disconnection of the link without disturbing the remainder of the system.

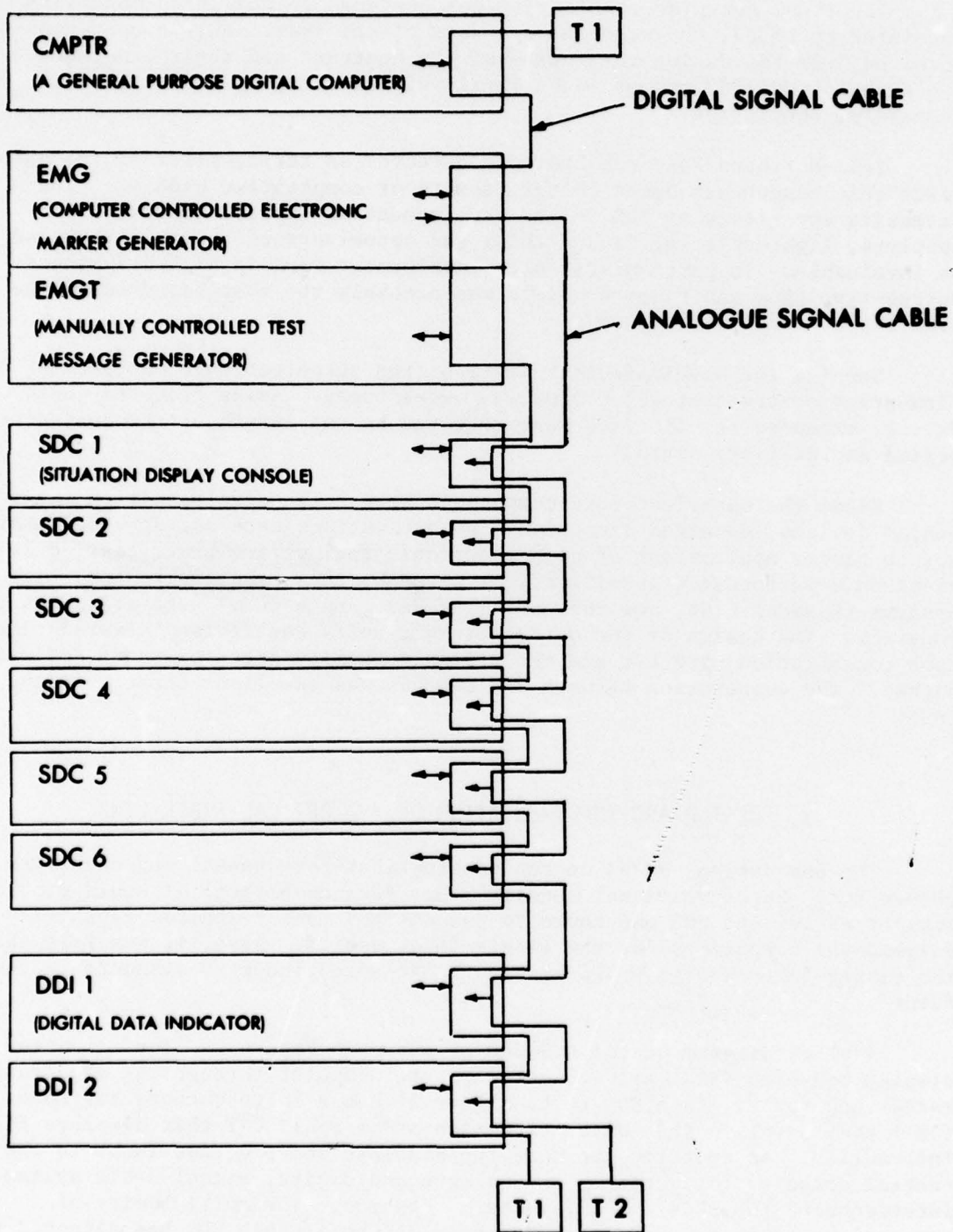
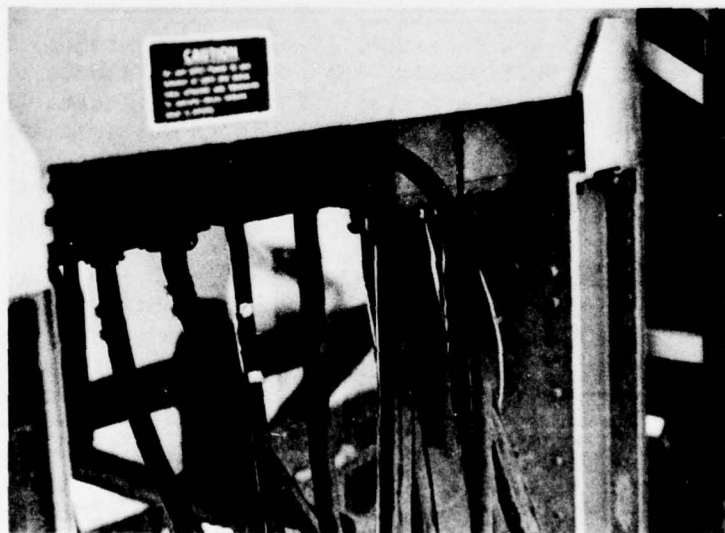

Figure 2. Block Diagram of the CCS-280 Display Subsystem.
An analogue and digital signal cable system was used in the CCS-280.



*Figure 3. Situation Display Consoles.
Three Situation Display Consoles located at the Canadian Forces Fleet School are shown.
The consoles have 12" diameter and 5" (diagonal) cathode ray tubes.*



*Figure 4. SDC Interconnecting Cables.
The two digital coaxial-cable plugs are seen on the right hand side. Two grounding straps are located next to the digital plugs. The two analogue-signal cable plugs are on the left hand side.*

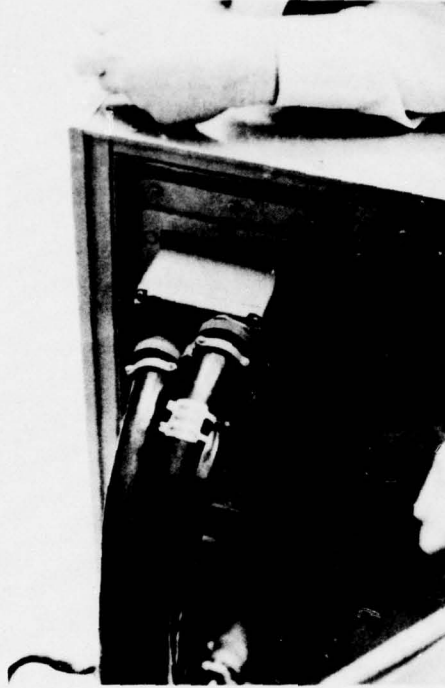

Figure 5. A Close-up of the CCS-280 Digital Coaxial Cable. Two cables each containing 35 coaxial cables are connected to a single plug. The photograph shows two plugs aligned vertically at the back of the EMG.

The coaxial cables transmit data and control signals in digital form. Among the 54 lines that are used actively, there are 32 bidirectional data lines. Since bidirectional optical-fiber links are impractical to construct at present, some degree of multiplexing was required to reduce the number of transmission lines to a manageable number. The number of data lines was reduced to 10 (5 in each direction) by time-division multiplexing. The control lines were not multiplexed because of the random nature of their pulse timing. Table 2 summarizes the functions of the resultant 31 optical transmission lines.

Examples of the pulse timings are shown in Figure 6. A clock rate of 10 Mb/s was chosen for the multiplexing/demultiplexing (MUX/DEMUX) system in order to take advantage of the readily available transistor-transistor logic (TTL) technology. Although the maximum bit rate was set at 10 Mb/s, rise and fall times of 10 ns were required to preserve the relative positions of the leading and trailing edges of the critical timing pulses. The stringent timing condition also imposed another difficult requirement on the system, namely, that the skewness between any two lines be 20 ns or less. The requirements of the input and output pulses of the optoelectronic units are shown in Figure 7. Due to the random nature of the control pulses of the CCS-280, where certain logic states are maintained for periods in excess of

100 μ s, the optoelectronic system was required to be not only TTL compatible, but also DC coupled. The electronic specifications for the optoelectronic system are listed in Table 3.

TABLE 2

Number of Optical Transmission Lines

FUNCTION	OPTICAL TRANSMISSION LINES
Output Data/Parity	5
Output Controls	6
Symbology Output	10
Reset, Synchronization	3
Input Data/Parity	5
Input Controls	1
Light-Pen Interrupt	1
TOTAL	31

TABLE 3

Electronic Specifications for the Optoelectronic Units

Maximum bit rate	10 Mb/s
Rise and fall times	< 10 ns
Error rate	< 1 in 10^9 bits
Skewness between any two channels	\leq 20 ns
DC Coupled, TTL compatible	

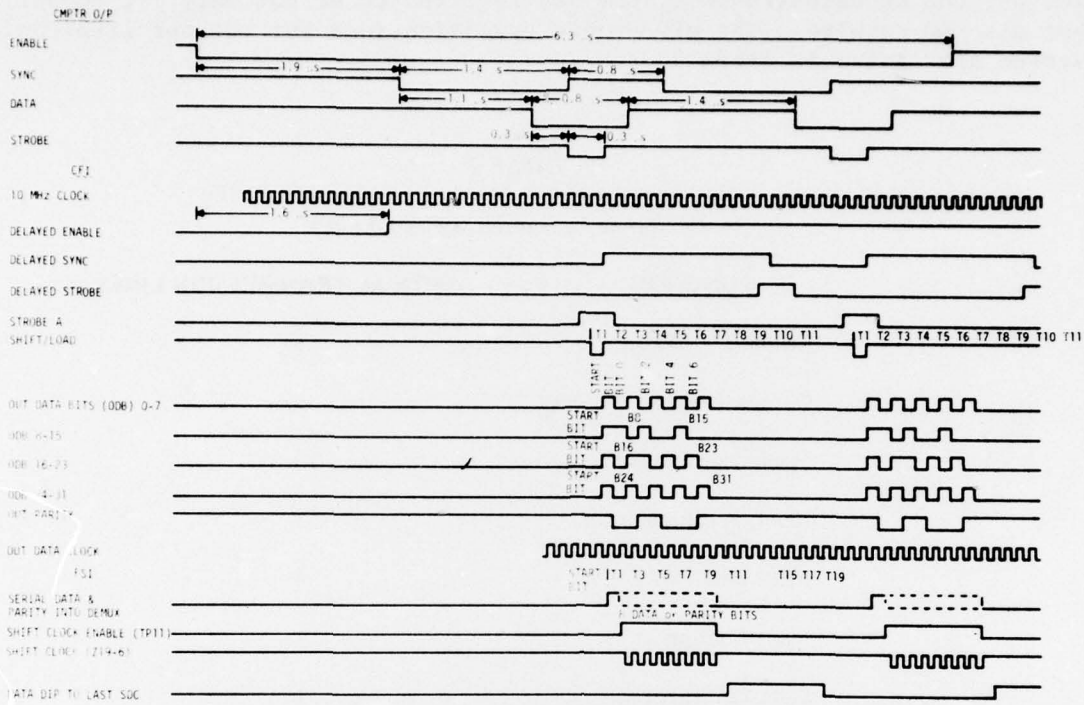

Figure 6. Multiplexing-Demultiplexing System Signals. An example of timing relations between various signals is shown.

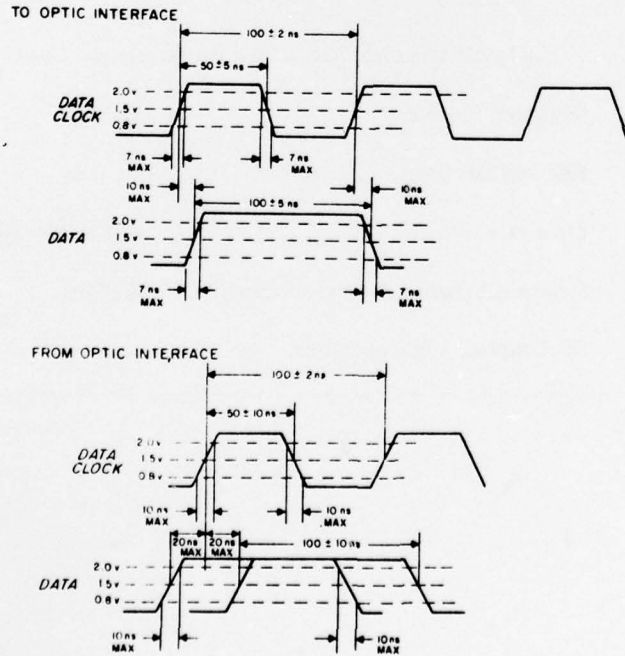

Figure 7. Timing Requirements for the Optoelectronic Units. The rise- and fall-times are less than 10 ns. "Skewness" between any two channels is less than 20 ns.

The general assembly of the optical link is shown in Figure 8. The optoelectronic components[†] are housed with the multiplexing and demultiplexing system in two cabinets, as shown. The coaxial-cable transmission system is terminated at a J box contained in the coax-fiber-interface cabinet. A block diagram of the optical-fiber link^{††} is shown in Figure 9, and the functional diagram of the multiplexed optical link is given in Figure 10.

[†] Details of the electronic and mechanical design of the optoelectronic components are contained in the Instruction Manual entitled "Optical Fiber Link Components of the Command and Control System 280" prepared by Bell-Northern Research Ltd. This document is available on a need-to-know basis from DND.

^{††} Engineering details of the optical link are contained in the report "Documentation for the Experimental Fiber Optical Fiber Link for the Command and Control System 280 (SK 8660-3)" prepared by Litton Systems (Canada) Ltd.. This document is available on a need-to-know basis from DND.

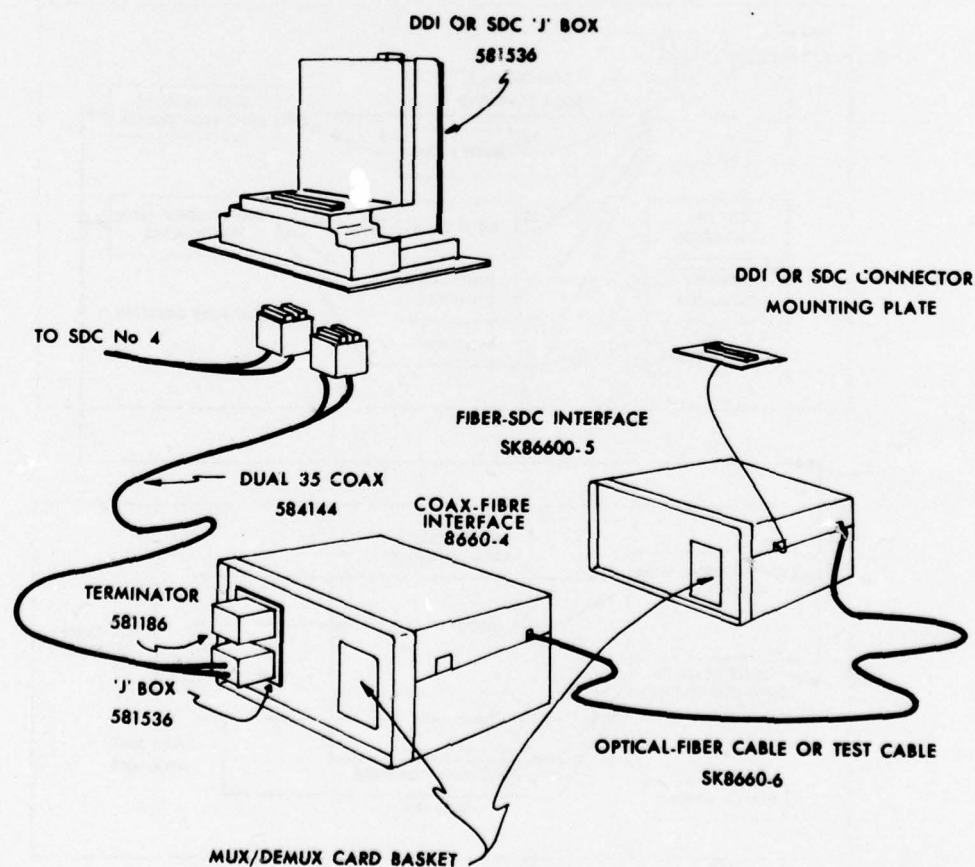

Figure 8. General Assembly of the Optical-Fiber Link.
The dimensions are not to scale. The cabinets are approximately 12" x 34" x 56" in size.

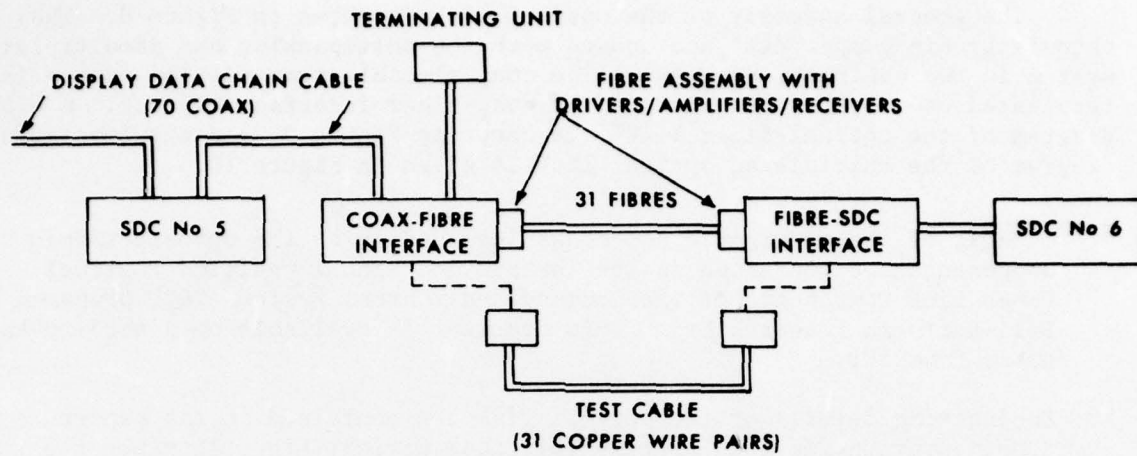

Figure 9. Block Diagram of the Optical-Fiber Link.
 A test cable consisting of 31 twisted copper wire pairs was used to test the multiplexing and demultiplexing (MUX/DEMUX) system.

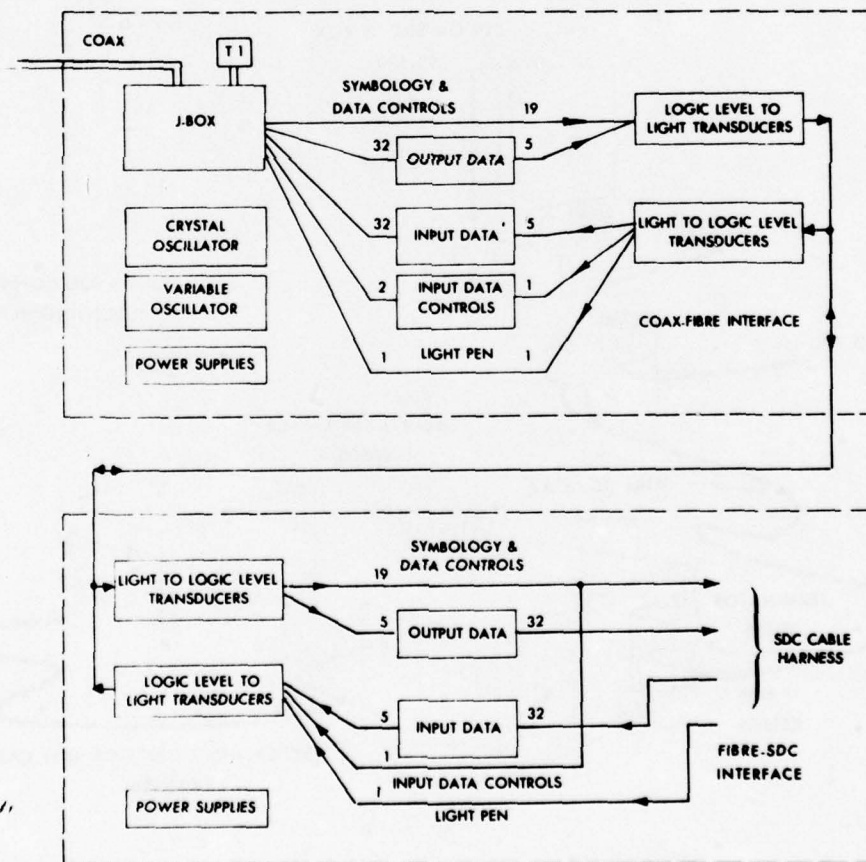

Figure 10. Functional Diagram of the Optical-Fiber Link.
 Only the 32 data lines were multiplexed to 10 lines, 5 lines in each direction.

Figure 11 shows a transmitter and receiver pair, along with a short optical-fiber used for testing the units. A schematic diagram of the optical cable and connections to the optoelectronic units is shown in Figure 12. The optical cable contained 11 spares in addition to 31 active lines. Its length was 4 m, but could have been several hundred meters long without changes in the basic design of the optical link.

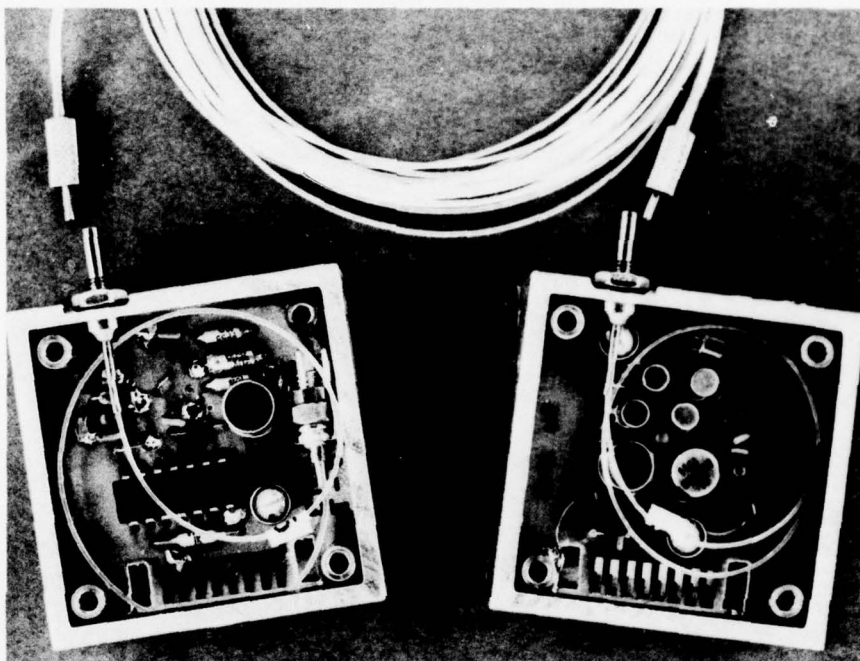

Figure 11. Optoelectronic Plug-In Units.

The fiber connectors are disconnected. Dimensions of the cases are 0.9" x 2" x 2". The transmitter is on the lefthand side. A stud-mounted light-emitting-diode (LED) is used in this example. The CCS-280 units used LEDs mounted in TO-18 transistor headers.

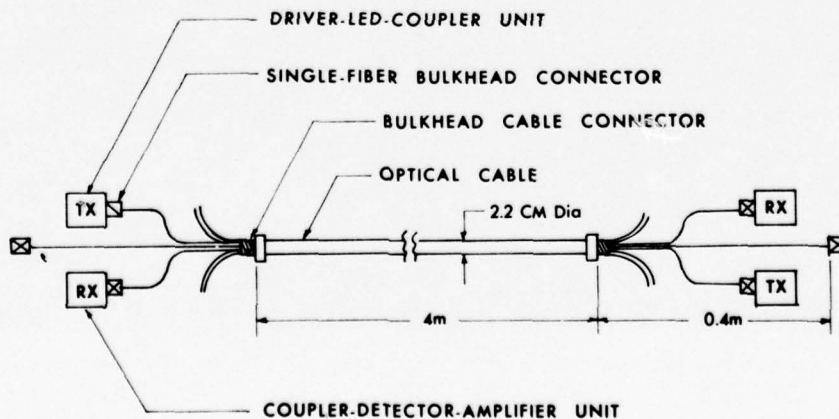

Figure 12. Optical Fiber Cable Connections.

Thirty-four fibers out of a total of 42 were terminated with single-fiber bulkhead connectors.

The cabinet containing the optoelectronic units, MUX/DEMUX system and power supplies is shown in Figure 13. The plug-in box on the front panel is a termination unit for the coaxial cables. The optical cable is connected to the right of the cabinet and the multitude of optical fibers can be seen at the centre of the figure.

Figure 14 shows the array of optoelectronic units in position. The layout of the optical fibers from the optical cable on the right to each optoelectronic plug-in unit is seen. The cage at the lower righthand side of the figure contains the MUX/DEMUX system.

In order to test the performance of the MUX/DEMUX circuitry independently the optical-fiber system was replaced by a hard-wire (twisted-wire pair) cable, 1 m long. Figure 15 shows the test cable interconnecting the two cabinets. The plug to the optoelectronic system is seen disconnected on the lefthand side of the figure. The black cable curving upwards from right to left in the figure is the optical cable.

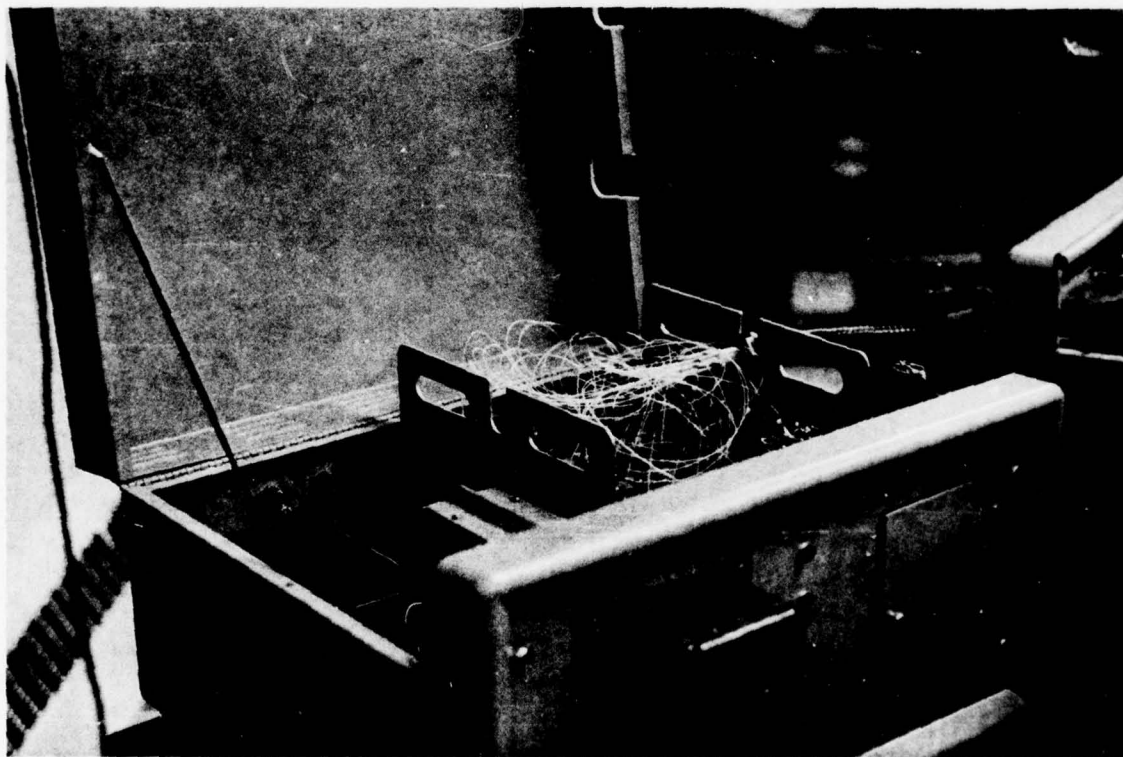

*Figure 13. Optical Link Cabinet.
The cabinet dimensions are approximately 12" x 34" x 56".*

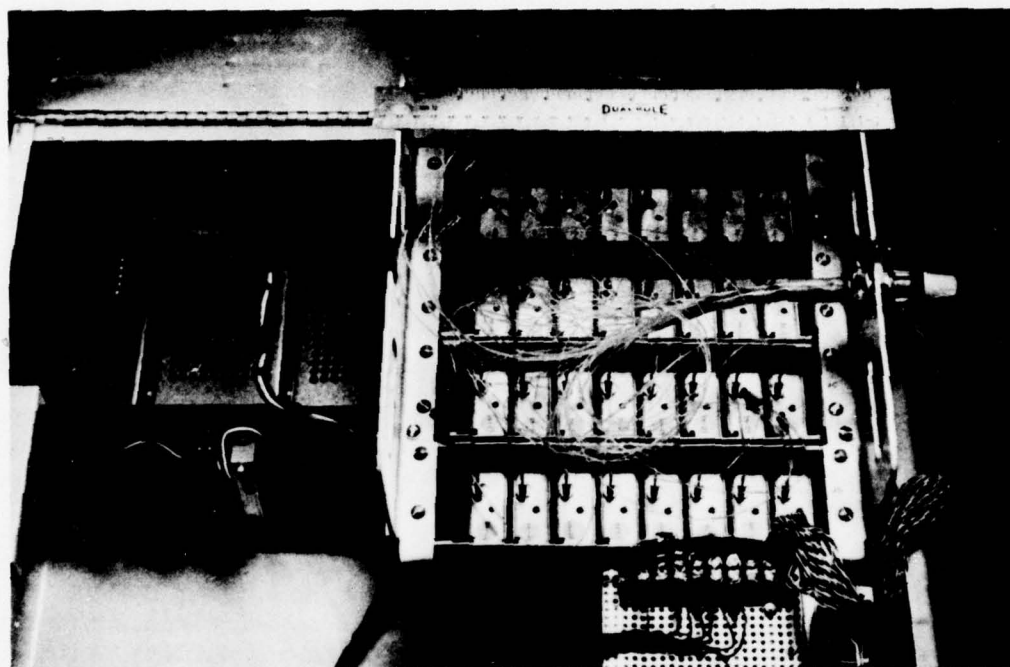

*Figure 14. Optoelectronic Plug-In Units.
The units are housed in a large cabinet in order to avoid difficulties that may arise in a closely packed system.*

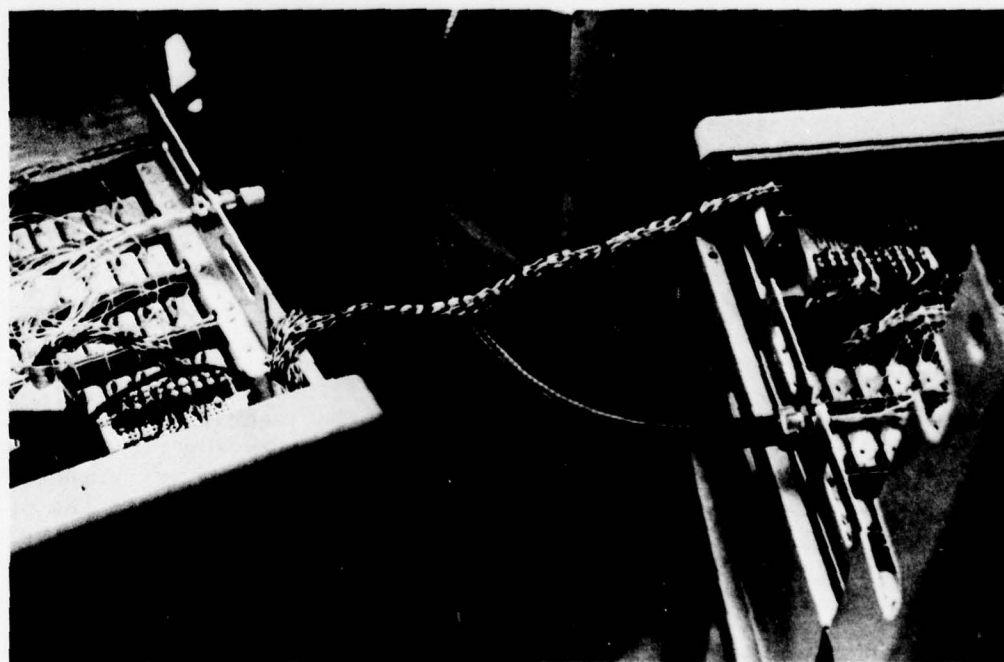

*Figure 15. Hard-Wire Test Cable for the MUX/DEMUX System.
The cable consists of twisted copper wire pairs.*

4. INSTALLATION AND TESTING OF THE OPTICAL LINK AND COMPONENTS

The method of testing and the results of the acceptance tests for the optoelectronic units are summarized in Appendix D. All electronic specifications were met according to the test procedures outlined in the Appendix. After installation of the units, some desirable modifications became apparent. Several improvements, such as the use of a stud-mounted LED, better quality potentiometers and improved layout, have already been incorporated into optoelectronic units manufactured currently by BNR. These improvements were considered not be necessary for the present application because the basic function of the units was not affected significantly.

The multiplexing-demultiplexing system and optoelectronic units were tested at Litton Systems (Canada) Ltd., following the test procedures described in Appendix E. The tests revealed only one system fault, namely, that the output pulse width varied with a change in duty cycle. This problem was eliminated by increasing the current flow through the zener coupling diodes in the receiver units.

The optical link was then installed and operated between the 5th and 6th SDCs of the CCS-280 located at the Canadian Forces Fleet School, Combined Support Division (CSD) in Halifax, N.S. In order to accommodate the extra delay time of 1.6 μ s necessary for the multiplexing and demultiplexing of data signals, a minor modification was performed on the electronic marker generator (EMG). Changes in circuitry[†] were made on two spare printed-circuit boards, which were installed in place of the original boards in the EMG. The modification introduced a 1 μ s delay to most of the "symbol/character/vector" control signals and to all of the analogue signals. The generation of the "Ready" signal was also inhibited. However, the operation of the CCS-280 was not affected because a substitute "Ready" signal was generated in the demultiplexer.

The Acceptance Criterion for the optical link was specified in the contract with LSL. Tests devised for the acceptance of the optical link were basically identical to the system performance tests. The Acceptance Tests were passed with zero defects and the optical link was judged by DMCS7 to exceed specifications. An account of the Acceptance Tests can be found in Appendix F.

After completion of the Acceptance Tests, the Optical Link was disconnected and the CCS-280 returned to its original state. The link was reinstalled by CRC and LSL in January 1976 for the technical evaluation (Tech-Val) of the Optical Link which was carried out by the Combined Support Division on behalf of DMCS7. After the voltage and timing adjustments were completed, some initial breakdown problems were encountered with the optoelectronic units. With the replacement of the defective units the operation of the optical link was found to be satisfactory. Details of the Tech-Val will be contained in a report to be issued by DND.

[†] Details of the modifications are found in the "Documentation for Experimental Fiber Optical Link for the Command and Control System 280 (SK 866-3)" supplied by LSL. This document is available on a need-to-know basis from DND.

5. CONCLUSIONS

The CCS-280 Optical-Link Task has demonstrated that optical-fiber transmission systems can be used effectively in action data systems where complex digital signals ranging from DC to 10 Mb/s, and with fast rise and fall times, are transmitted. The single-fiber-per-channel design was shown to be satisfactory and no difficulties were experienced in handling the optoelectronic components during installation and testing. Multiplexing of the data lines was accomplished despite the stringent timing requirements imposed by the CCS-280. The multiplexing and demultiplexing system was also shown to operate satisfactorily when interconnected by the hard-wire cable. The digital cable connectors can therefore be simplified by reducing the number of required transmission lines through multiplexing.

The demonstration link was designed to be connected externally to the existing components of the CCS-280, in order to allow the system to be returned conveniently to its original state. A considerable simplification of the cable system could be accomplished by integrating the optical link into the overall system design.

The expected spin-off from contracting the development and installation of the optical link to private industry was also realized. The contract with BNR contributed in part to their development of optoelectronic system components. Experience and familiarity gained by LSL in the application of optical-fiber transmission systems has provided a basis for their involvement in future optical-link projects. Applications of optical-communications technology to military communication systems are expected to increase in the coming years. In view of the number of advantages, such as immunity to EMI and small size, optical-fiber transmission links will no doubt be considered in applications such as the transmission of radar-video and sonar signals, and transducer signals generated by temperature, pressure, rpm and volume sensors, as well as in action data-systems.

6. ACKNOWLEDGEMENT

The authors acknowledge the support of Cdr. J.W. Mathewson, and Mr. S.F. Knights of the Action Information Systems Section, Directorate of Maritime Combat Systems, Department of National Defence. The prime impetus for the CCS-280 Optical-Link Task was provided by S.F. Knights, who worked with the Department of Communications and the contractors throughout the Task, from inception to completion. His technical contributions and encouragement are also gratefully acknowledged. We also wish to thank Cdr. C.G. McIntyre of the Combined Support Division, Canadian Forces Fleet School, for his cooperation during the acceptance tests.

The support and guidance provided by Dr. J.F. Perrier, Director of Communication Techniques and Equipment Research, is gratefully acknowledged.

7. REFERENCES

1. Miller, S.E., E.A.J. Marcatili and Tingye Li, *Research Toward Optical-Fiber Transmission Systems Part I: The Transmission Medium*, Proceedings of the IEEE, Vol. 61, No. 12, Dec. 1973, pp. 1703-1726.
2. Miller, S.E., Tingye Li and E.A. J. Marcatili, *Research Toward Optical-Fiber Transmission Systems Part II: Devices and System Considerations*, Proceedings of the IEEE, Vol. 61, No. 12, Dec. 1973, pp. 1726-1751.
3. Thiel, F.L., and W.B. Bielawski, *Optical Waveguides Look Brighter than Ever*, Electronics, Vol. 47, No. 6, March 21, 1974, pp. 89-96.
4. *Fiber-Optic System Carries Voice, TV and Data Signals*, Electronics, Vol. 48, No. 21, October 16, 1975, pp. 29-30.
5. Compton, R.D., *Fiber Optics Puts it All Together*, Electro-Optical Systems Design, Vol. 7, No. 6, June 1975, pp. 14-24.
6. Elson, B.M., *Fiber Optics Technology Pushed*, Aviation Week & Space Technology, Vol. 100, No. 23, June 10, 1974, pp. 41-46.
7. Andrews, R.A., A. Fenner Milton and Thomas G. Giallorenzi, *Military Applications of Fiber Optics and Integrated Optics*, IEEE Transactions on Microwave Theory and Techniques, Vol. MTT-21, Dec. 1973, pp. 763-769.
8. Stickley, C.M., D.J. Albares, H.F. Taylor, T.G. Giallorenzi and A.F. Milton, *Anticipated Uses of Fiber Optics and Integrated Optics in the Defense Department*, Invited paper presented at the Topical Meeting on Integrated Optics, Optical Society of America, January 21-24, 1974, at New Orleans, Louisiana, U.S.A.
9. *Fiber Optic Interconnections for Electronic Systems of 2000-ton Surface Effect Ships (2KSES)* NELC/TD333, Electro-Optics Technology Division (Code 2500), Naval Electronics Laboratory Centre, San Diego, California U.S.A., 28 June, 1974.
10. Martin, W.E. and D.J. Albares, *Fiber- and Integrated-Optic Communication Technology*, NELC/TR1891, 24 August 1973, Naval Electronics Laboratory Center, San Diego, California, U.S.A.
11. Allard, F.C., *A Fiber Optics Sonar Link*, Electro-Optical Systems Design, Vol. 8, No. 2, Feb. 1976, pp. 32-35.
12. Munn, R.E. and T.A. Meador, *Fiber-Optics Remote Link for AN/PPS-18 Radar*, NELC/TD314, Naval Electronics Laboratory Center, San Diego, California, U.S.A., 5 August, 1974.
13. Albares, D.J., L.U. Dworkin and K.C. Trumble, *Prospective Applications for Fiber Transmission in the Military*, Invited paper presented at the Topical Meeting on Optical Fiber Transmission, January 7-9, 1975, Williamsburg, Virginia, U.S.A.

APPENDIX A

The CCS-280 Cable-Breakage Problem

A chronic pin-breakage problem was encountered in the CCS-280 digital cable system during routine maintenance procedures. The problem occurred in the interface between the coaxial cables and the connector pins. Each cable was soldered to a twisted pair and the other ends of the twisted pair were soldered to the connector pins. Any twist or strain on the outer armour of the cable placed an undue stress on the twisted pairs, thus causing either a failure at the soldered joint or the pulling of a pin from the plug.

CRC undertook to examine the possibility of applying optical-communications technology to solve the CCS-280 cable breakage problem and arrived at the following conclusions:

- A. The problem could be solved by the following conventional remedies:
 - i) Redesign the cable clamping structure on the connector casing to clamp the cable securely so that the mechanical strain will be born fully by the protective outer-casing of the cable.
 - ii) Develop a cable using much smaller coaxial cables such as RG-178u in order to make a lighter and more flexible cable system.
 - iii) Develop a multiplexed system to reduce the number of transmission lines.
- B. The use of an optical-fiber transmission system is not particularly advantageous in the CCS-280 for the following reasons:
 - i) Not all of the advantages of optical-fiber links (c.f. Appendix B) are put to use effectively in this application.
 - ii) At present, optical-fiber links are difficult to operate bidirectionally. Since the CCS-280 data lines are bidirectional, one-to-one replacement of coaxial cables with optical fibers would increase the number of required transmission lines.
 - iii) A multiplexing scheme to reduce the number of transmission lines would also be more effective with coaxial cables than with optical cables if the data lines are operated bidirectionally.

The conclusions were discussed with DMCS7, who confirmed that a new cable clamping system and a multiplexing system were under consideration. However, no action had been taken by DND on the multiplexing problem because of prior commitment to higher priority tasks.

APPENDIX B

Advantages of Optical-Fiber Waveguides

The optical-fiber waveguide (1), (2), (3), (4), (5) is being considered for military applications with increasing frequency over the past few years (6). Table B-1 summarizes the advantages and disadvantages of the optical fibers for military applications.

TABLE B-1

Advantages and Disadvantages of Optical-Fiber Waveguides for Military Applications

ADVANTAGES

- i) Elimination of electromagnetic interference and crosstalk
- ii) Improvement of security through elimination of RF leakage
- iii) Elimination of ground loop problems
- iv) Reduction of size and weight
- v) High-temperature stability
- vi) No sparking
- vii) No corrosion

DISADVANTAGES

- i) Technology not well established
- ii) Requires additional upconversion and downconversion interface units
- iii) Bidirectional operation difficult to implement at present
- iv) No power transmission capability

One significant advantage of optical fibers is their immunity to electromagnetic interference (EMI) (7). The optical frequencies are of the order of 10^{14} Hz while EMI frequencies are generally much lower than 10^{10} Hz. In other words, the optical fiber is essentially transparent to EMI because the constituent material is glass, a good dielectric material, and no interference is picked up by an optical-fiber waveguide placed in a high EMI environment.

The leakage of optical power from an optical fiber is readily blocked by a suitable plastic coating that absorbs light. Crosstalk between optical-fiber transmission lines can therefore be eliminated.

The absence of crosstalk also makes eavesdropping of signals transmitted by optical fibers extremely difficult unless the fibers themselves are "tapped". An optical-fiber transmission system can be designed so that appropriate alarms or discontinuance of transmission occur whenever an attempt is made to "tap" the fiber.

Since the optical fiber is an insulating dielectric, no electrical current can flow through an optical-fiber transmission system. Therefore, troublesome ground loop problems can be eliminated completely.

Because of the small size of the optical fiber, typically 150 μm diameter, optical-fiber cables can be designed to carry many transmission lines through a given conduit size. The reduction in size compared to the coaxial cable will also result in significant savings in terms of weight.

The optical fiber itself has a high melting point because of the glass material and remains stable at high temperatures, even when the plastic jacket reaches melting temperature. Therefore, fibers can be used in areas where there is a possibility of exposure to high temperatures.

In some applications, short circuiting of coaxial cables can cause sparking and trigger an explosion in a hazardous atmosphere. Optical fibers do not produce such sparking and can be used safely in such atmospheres.

The optical fiber is fabricated from glass or fused quartz. Therefore, unlike coaxial cables, optical-fiber cables are not as susceptible to corrosion when exposed to sea water and other corrosive environments.

The optical-fiber technology is a new technology that is being developed and no standards have been established yet. In comparison, transmission media such as the coaxial cable has a well established technological standard and their properties are well understood. More development work is needed to establish the optical-fiber technology as a viable alternative to other transmission technologies.

The optical fiber requires circuitry to convert the electronic signal to an optical frequency and back to an electronic signal again. The extra circuitry could introduce additional complexity in a system.

At present the optical fiber cannot be used readily to transmit signals bidirectionally. Two separate fibers therefore will be required to replace a single bidirectional transmission line.

Copper cables can carry DC and AC power required for operating terminals and repeaters in addition to the electronic signals. In contrast, since the optical fiber is a dielectric waveguide, it cannot transmit such power. Local power sources or copper wire pairs will be required to energize repeater and terminals.

On the whole, in military applications, the optical fiber waveguides have many advantages in comparison to coaxial cables. The advantages such as weight reduction and immunity to EMI make the optical fiber an attractive transmission line for aircraft and naval vessels. For example, an optical-transmission system is being tested in the navigation and weapon delivery system of an A-7D attack aircraft of the United States Navy⁽⁸⁾. The optical fiber can also be applied to data-bus systems which carry many different multiplexed signals and serve a number of widely separated communication terminals⁽⁹⁾⁽¹⁰⁾.

The absence of crosstalk, ground loop problems and immunity to EMI make the optical fiber an ideal medium for point-to-point signal transmission. Experimental optical links for submarine sonar arrays⁽¹¹⁾ and battlefield radar⁽¹²⁾ have been developed. Also, resistance to corrosion together with the small size and light weight make the optical fiber an attractive candidate for tow cables for undersea platforms⁽¹³⁾. The application of optical-fiber waveguides to military communication systems is expected to increase further in the future.

APPENDIX C

Task Description

The Task was defined as the construction and testing of an experimental optical-cable link with a total budget of \$195,000.00. This amount was reduced by DND to \$180,000.00 in October 1975. No unforeseen difficulties were encountered in the tests and debugging, and the Task was completed within budget and 3 months ahead of schedule.

The monthly reports submitted by the prime contractor, Litton Systems (Canada) Ltd., Rexdale, Ontario, were substituted as the reports on completion of each work phase. The work schedule determined by LSL was 2.5 months shorter than that in the Task Description, allowing for some contingencies. Table C-1 summarizes the Task Description.

TABLE C-1

Task Description Summary

TITLE: OPTICAL LINK FOR THE CCS-280 SYSTEM

SPONSOR: DGMEM/DMCS 7 (AI)

PROJECT OFFICER: Mr. S.F. Knights (992-3673)

BACKGROUND: The Command and Control system (CCS-280) consists of 20 units which are connected together by data information cables. These form two bundles each containing 35 coaxial lines and 7 copper wires and, together with associated connectors, produce serious interruption of the command and control system during maintenance and under operational conditions. Such interruptions could result in severe reduction of combat effectiveness. In addition these cables present ground-loop problems and are susceptible to radio frequency interference.

AIM: To design, construct and test a prototype optical-cable link by the application of optical communications techniques. The intent is to reduce the number of data carrying conductors, eliminate ground-loop problems, reduce radio interference and improve cable flexibility.

SECURITY CLASSIFICATION OF TASK: UNCLASSIFIED

RESOURCES TO BE SUPPLIED BY SPONSOR: \$195K for studies and capital equipment. \$1.5K in FY 73/74, \$14K in FY 74/75 and \$179.5K in FY 75/76. FE's to terminate *only* on completion of task or full expenditure of funds.

REQUESTED START DATE: 1 October, 1973 – Revised 1 April, 1975.

COMPLETION ACTION: Successful operation of prototype equipment on the CCS-280 located at the Combined Support Centre, Halifax.

DND RESEARCH ESTABLISHMENT: DREO/Communications Research Centre (CRC)

PROJECT SCIENTIST: Dr. A. Watanabe/Dr. E. Hara

WORK PLAN:

1. System engineering study (FSR)* and optical link component evaluation (CRC).
2. Serializing (FSR), optical cable (FSR), optical link and mechanical systems design (CRC & FSR).
3. Serializing unit construction (FSR), optical cable fabrication (contract) and optical-link construction (CRC & FSR).
4. Integration and test followed by installation into combined support centre for initial operational test (CRC & FSR).

* *Field Service representative, industrial company.*

SCHEDULE: 1. Oct. 73 to April 74 2. May 74 – June 75 3. June 75 –
3. June 75 to Dec. 75 4. Jan. 76 – Mar. 76

REPORTING PLANS: DREO Quarterly Progress Report and on completion of each work plan phase.

APPENDIX D

Acceptance Tests for the Optoelectronic Plug-In Units

The test configuration for optoelectronic plug-in units is shown in Figure D-1. Table D-1 lists the step-by-step test procedure, which was prepared by BNR. The test bench was wired to accept six optical-fiber links, one of which was the Reference Channel. Pseudo-random pulses were generated by a Hewlett-Packard 3760A Data Generator and errors were detected by an HP 3761A Error Rate Detector. Initially, the performance of the Reference Channel was measured, and then the other five links were connected and tested. The procedure was repeated in groups of six until all the units were tested.

Table D-2 lists the results of the Acceptance tests. The electronic specifications were met and no errors were detected in 10^9 pulses. In particular, the transmission delay times of each set did not differ from each other by more than 20 ns as specified by the "skewness" requirement.

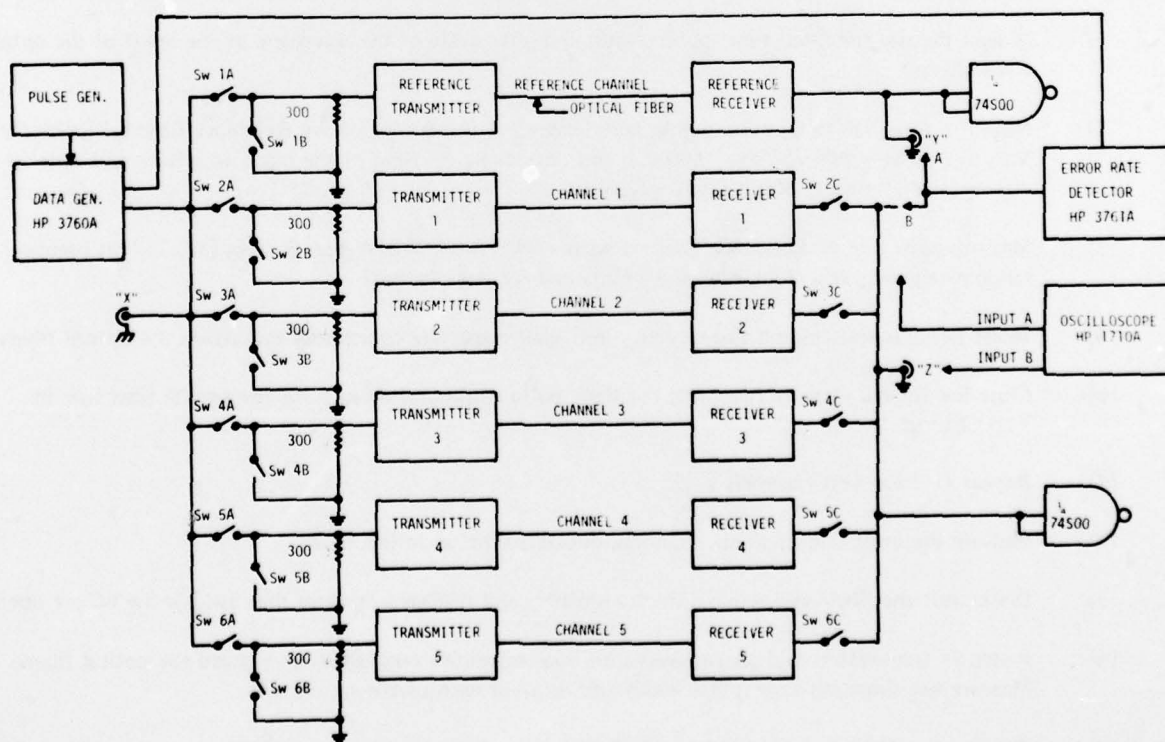

Figure D-1. Test Arrangement for the Optoelectronic Plug-In Units.
The units were tested in batches of 6.

TABLE D-1

Test Procedure for the Optoelectronic Units

The purpose of the test procedure is to ensure that the optical fiber link components meet the specifications outlined in the contract. These specifications for the input and output of the DC coupled, TTL compatible system are:

- 1) Maximum bit rate = 10 Mbs.
- 2) Rise and fall times < 10 ns.
- 3) Error rate less than 1 in 10^9 .
- 4) The skewness between any two channels \leq 20 ns.

TEST PROCEDURE

- 1) Distribute the input to the six optical transmitter connectors by closing switches Sw 1A – Sw 6A.
- 2) Ensure that switches Sw 1B – Sw 6B and switches Sw 2C – Sw 6C are in the open position.
- 3) Insert a transmitter and receiver into their respective Reference Channel connectors and attach the optical fiber.
- 4) Turn on power supplies and adjust data input level to 3V.
- 5) Connect Channel A input of the oscilloscope to the point marked "x", and Channel B input to the point marked "y" (Figure D-1).
- 6) Adjust the rise time, fall time, pulse width, and duty cycle of the waveform at the input of the optical transmitters.
- 7) Note rise time, fall time, pulse width, and delay τ_d at the output of the Reference Channel (point "y"). Vary the pulse width, (50 ns – 500 μ s), and duty cycle (1–50%) of the input waveform and note its effects on the output. Reset input waveform.
- 8) Measure error rate of Reference Channel with a HP 3760A/3761A Test System (32, 767-bit pseudo-random sequence at a clock rate of 10 Mb/s and RZ data format).
- 9) Insert five transmitters and five receivers into their respective connectors and attach the optical fibers.
- 10) Close Sw 2C and measure rise time, fall time, pulse width and delay τ_d of the optical fiber link in Test Channel 1.
- 11) Repeat (12) for Test Channels 2–5.
- 12) Measure the error rate of all six channels, one at a time, as in (8) above.
- 13) Disconnect the fibers and remove the transmitters and receivers. Ensure that Sw 2 – Sw 6C are open.
- 14) Insert six transmitters and six receivers into their respective connectors and attach the optical fibers. Measure rise time, fall time, pulse width and delay of each of the six units.
- 15) Repeat steps (12), (13), and (14) until all the components have been tested.

TABLE D-2

Optoelectronic Unit Acceptance Tests

Plug-in Units: Tx/Rx Serial Nos.	Output Pulse Width (ns)	Transmission Delay (ns)	Error in 10 ⁹ pulses	Pulse Rise Time (0.7V to 2V) (ns)	Pulse Fall Time (2V to 0.7V) (ns)
1/1	48.5	85	0	4	3
2/2	52	85	0	5.5	3
3/3	54.5	80	0	5	3
5/5	48	94	0	3.5	4
6/6	50	88	0	5	3
7/7	51	86.5	0	3.5	3.5
8/8	54.5	85	0	4.5	4
9/9	55.5	80	0	4	3
10/10	54	82	0	4	4
11/11	54	82	0	4	3
15/15	51	88	0	4	4
16/16	50	81	0	4	3
18/18	48.5	82.5	0	5	3
19/19	50	83	0	3.5	4
20/20	51	85	0	4	5
21/21	46	84	0	4	3
22/22	50	81	0	3.5	3
24/24	51.5	84.5	0	4	4
25/25	52	78	0	4	3
26/26	59	80	0	5.5	4
27/27	53	85	0	4	5
28/28	55	80	0	3.5	3
29/29	53	81	0	4	3
30/30	55	80	0	3.5	3
31/31	45	92	0	4	3
32/32	45.5	93	0	3.5	3.5
33/33	55	86	0	4	3
34/34	52	84	0	5	3
36/36	50	92	0	4	4
37/37	57	83	0	4	3
38/38	56	80	0	4	3.5
40/40	50.5	84	0	3.5	3
41/41	48	87	0	4.5	4
42/42	52	84	0	5	3

APPENDIX E

Testing of the Multiplexing-Demultiplexing System and Optoelectronic Units

The CCS-280 Task consisted of two major sub tasks, the multiplexing and demultiplexing of the data lines and the replacement of the coaxial cable lines by an optical-fiber system. The block diagrams of the multiplexing/demultiplexing (MUX/DEMUX) systems are shown in Figures E-1 and E-2. The system was designed to allow ready replacement of the optical-fiber system with a twisted-pair cable for test purposes. The operation of the MUX/DEMUX system was checked using the Radar Video Test (RVT) set. First, the accuracy of data transfer and the effects of some timing-signal delays were examined by using the twisted-pair interconnecting cable in place of the optical-fiber system. Next, the optical-fiber system was installed, and its performance compared with the previous results using the twisted-pair cable. With this arrangement, a quick check on the system operation was possible, and, if problems occurred, the fiber or MUX/DEMUX systems could be checked separately to determine the problem area. Required modifications were incorporated before installation in Halifax.

The test procedure employed by LSL in testing the MUX/DEMUX and optoelectronic units is contained in a document issued by LSL[†]. The tests were followed through, step-by-step, and malfunctions were corrected as they were uncovered. Only a few minor changes in circuits were found to be necessary. Some of the optical plug-in units were found to need individual adjustments because the required levels of LED output power and detector threshold differed from that of the Optoelectronic Acceptance Tests. The need arose primarily from the different directions of transmissions through the optical-fiber cable that was dictated by the system configuration.

During the testing the optical units were found to degrade the pulse width, when 50 nsec width pulses with a 50% duty cycle were applied. This problem was caused by insufficient current through the zener diode used for DC coupling in the receiver. It was corrected by increasing the current through the zener diode and then resetting the receiver thresholds and transmitter diode current. The pulse width was then adjusted by the threshold potentiometer at the receiver, and if the width was too wide at the potentiometer minimum, the drive current through the transmitter LED was decreased. It was noted that all optical units needed to be operated for at least five minutes to stabilize the pulse width. The net decrease in pulse width was 7 to 10 nanoseconds, with a 50 nsec pulse and a 50% duty cycle at a 10 Mb/s rate, from turn-on until the five minute warm-up was completed.

The tests at LSL plant were completed successfully according to the test plan and the optical link was shipped to Halifax for final installation.

[†] The document "Acceptance Test Procedure: Experimental Fiber Optic Link for the Command and Control Systems 280 (SK8660-2)" is filed at Central Registry, CRC under the title "Contract Documentation: Optical Link for the CCS-280", file No. 6040-5-1. They may be viewed on a need-to-know basis.

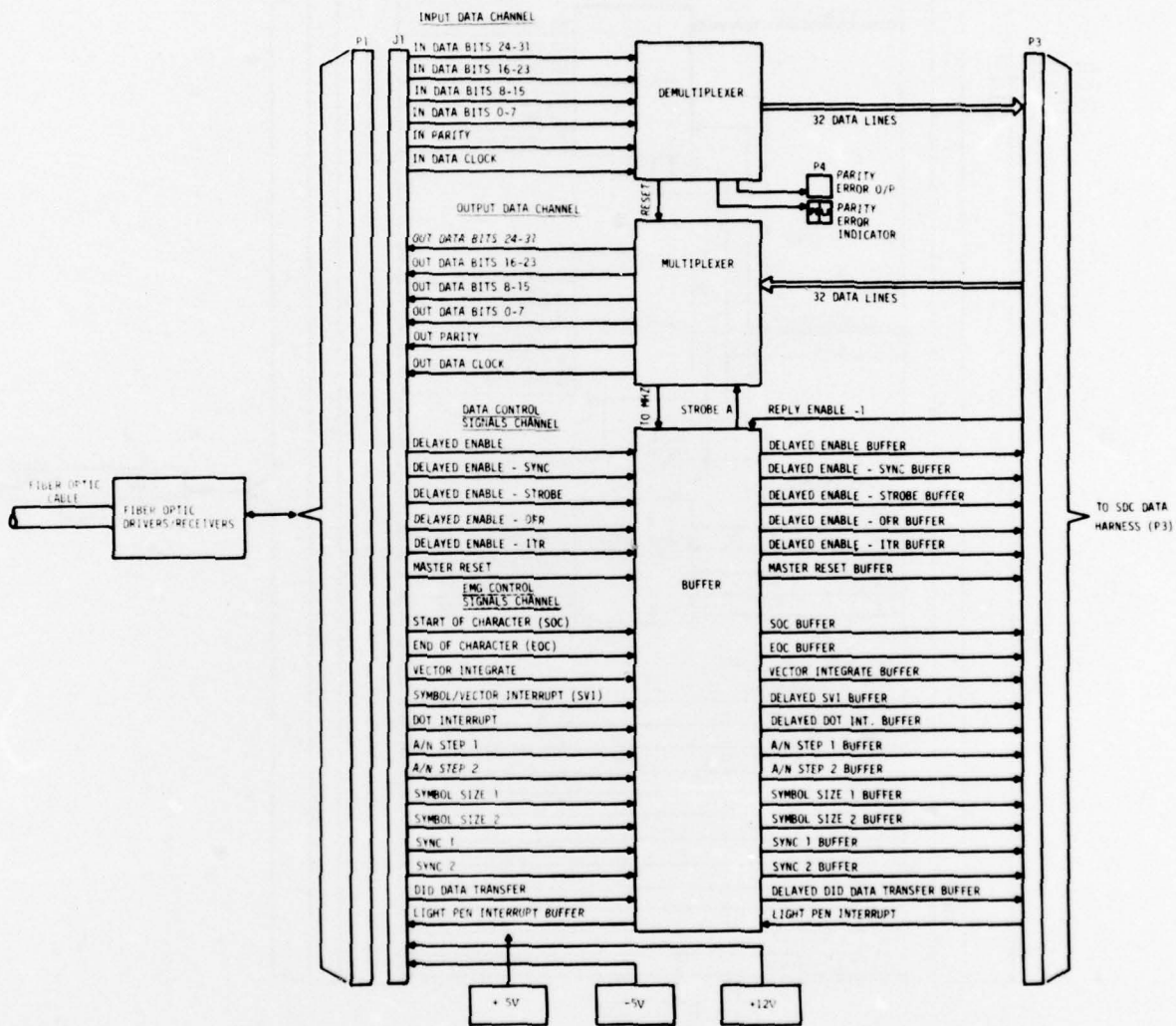

Figure E-1. Block Diagram of the MUX/DEMUX System: Input.

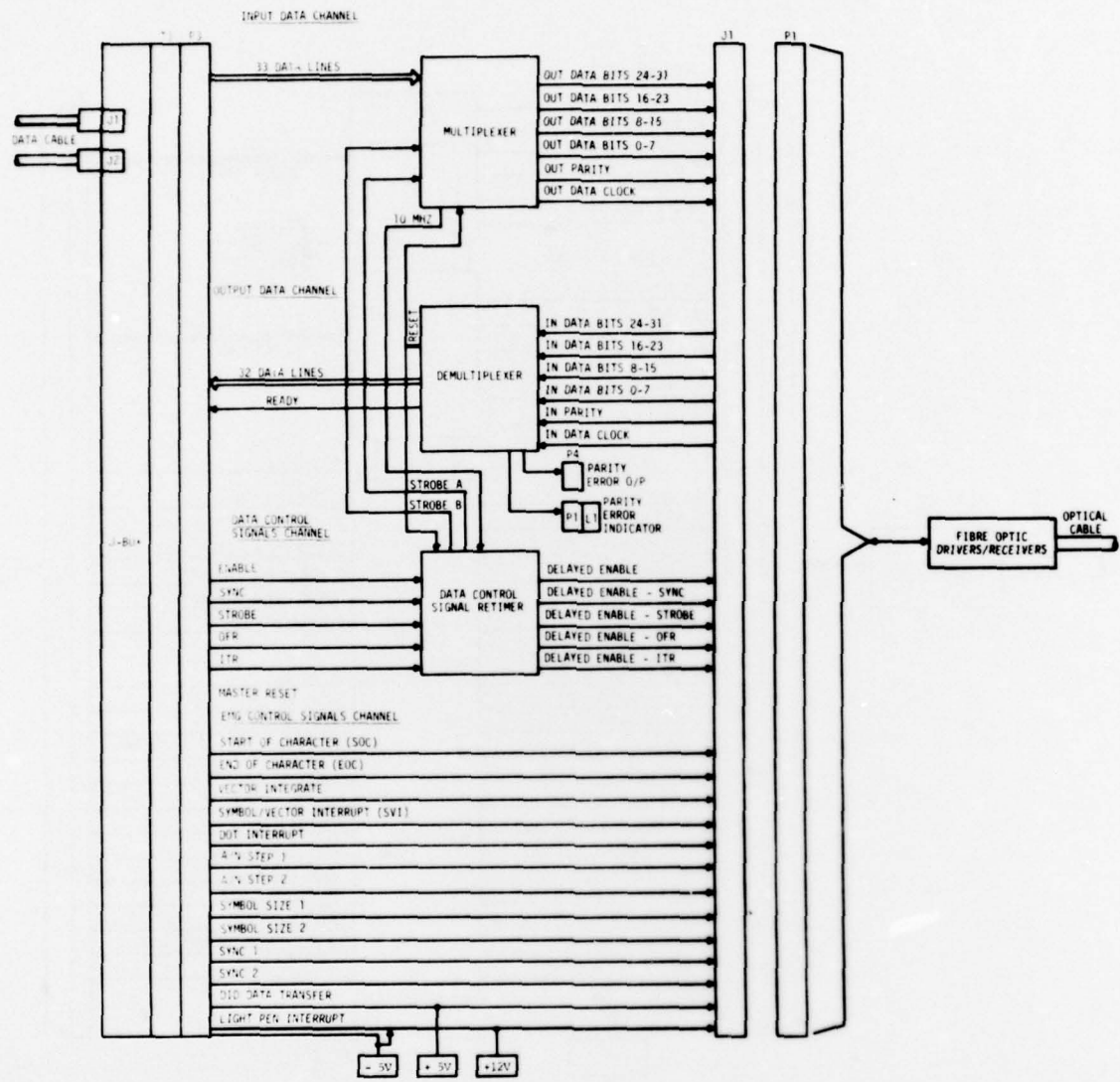

Figure E-2. Block Diagram of the MUX/DEMUX System: Output.

APPENDIX F

Acceptance Tests for the Optical Link

The final installation and tests of the optical link were carried out at the Canadian Forces Fleet School in Halifax during December 1975, approximately 1 month ahead of LSL's schedule. Initial operation of the MUX/DEMUX system, using the twisted-pair interconnecting cable, produced random displays of data on the SDC because of timing errors. These errors were corrected by following the SDL signals to the common point between the interface and SDC signals and then by adjusting the pulse delays. The delays were implemented by using 8-bit shift registers and the 10 MHz clock in the multiplexer. This gave a total delay of 0.8 μ s per register. Each delay was advanced 100 ns at a time and the results noted on the display. The two extremes of delay (too much and too little) were noted and the shift registers were set to the mid-point.

When the optical-fiber system was connected into the system, one optical transmitter proved to be temperature-sensitive and locked up the parity line, resulting in a false indication of continuous data errors. The transmitter was replaced with a spare. Two receiver thresholds were adjusted to remove threshold instabilities. The intermittent flashing on a multivector display was corrected by also adjusting the receiver threshold on the sync optical-line. A close examination of the SDC display showed that the forced "DOT Interrupt" was not functioning and the problem was cured by changing the delay of the interrupt-timing signal.

The final Acceptance Tests were carried out by the official examiner appointed by DMCS 7 (Mr. Kevin Chadwick). Step-by-step tests[†] were followed and test conditions were satisfied with zero defects. No flicker nor degradation of any kind was detectable on the display. The tests were carried out one step further into a simulated operational mode, and the optical link functioned without fault.

[†] The Acceptance Criterion and Test Procedures are filed in Central Registry at CRC under "Contract Documentation: Optical Fiber Link for the CCS-280". It is available for viewing on a need-to-know basis.