

AD-A035 488

OREGON STATE UNIV CORVALLIS SCHOOL OF OCEANOGRAPHY

F/G 8/10

EXPOSURE. A NEWSLETTER FOR OCEAN TECHNOLOGISTS, VOLUME 4, NUMBE--ETC(U)

JAN 77 J ANDERSON, A MAGNUSON, D A BYRNE

N00014-67-A-0369-0007

NL

UNCLASSIFIED

| of |
ADA035488



END

DATE
FILMED
3-77

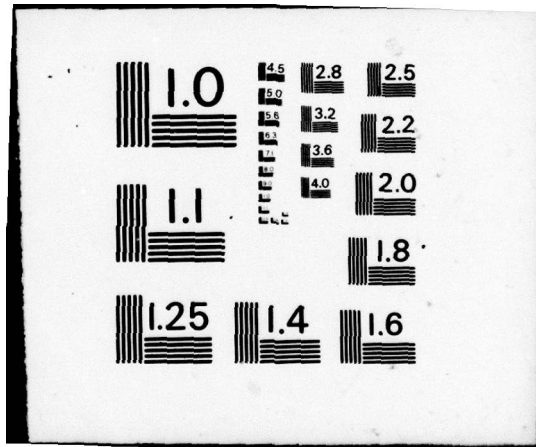

ADA 035488

15) NADA 14-67-A-0369-0007

9
p-50
12

EXPOSURE

vol. 4 no. 6

a newsletter for ocean technologists

John/Anderson, Albert/Magnuson,
David A./Byrne Robert C./Mitiguy

Volume 4, Number 6

CUBE-- A Simple, Low Cost Call-Up Buoy

12 12p.

Important Memorandum
On Page Eleven!

DDC
RECEIVED
FEB 10 1977
C.

Polar Research Laboratory, a Santa Barbara, California firm, carries out extensive programs in Arctic and SubArctic seas. As part of this work, instrumentation installations are made in areas such as the shallow marginal seas and continental shelf portions of the Arctic Ocean and the Bering Sea. Both cable-to-shore systems and self-contained instrumentation packages carrying their own data recorders are used. A major problem associated with instrumentation of these types is recovery of equipment for maintenance or for data retrieval. A simple, rugged marker buoy system capable of operation in water depths to about 600 ft, and with cost held to about \$1000, was required for the application. A buoy that could be called to the surface on command was necessary in order to survive storm seas and the advance and retreat of pack ice. Instrumentation packages including the call-up buoy have to be lightweight and compact because frequently only small craft such as Eskimo oomiaks are available for system installation and recovery. Retrieval system life has to be in excess of one year since many areas are accessible only a few weeks out of the year during the annual retreat of the pack ice.

11 January 1977

COPY AVAILABLE TO DDC DOES NOT PERMIT FULLY LEGIBLE PRODUCTION

272 268

4B

A call-up buoy system which fills the above requirements has been developed over the past four years through a number of evolutionary steps. The system includes a surface float which carries a radio beacon, a nylon buoy tether line, an anchor, a retaining strap secured by an explosive bolt for releasing the buoy and the electronics, and a power source for sensing a coded call-up signal and activating the explosive bolt.

The system can be configured in many ways but for purposes where work is in high current areas which are often covered by ice, the compact, low-profile package shown in Figure 1 was chosen. When the unit is in the "bottom" configuration all components are nested in a channel-shaped anchor. For marking heavy instrument packages or underwater cables, the anchor is tied to the unit to be marked by a heavy nylon line at least as long as the water is deep so that the anchor can be pulled to the surface before retrieving the bottom equipment.

The surface float, made of a low cost syntactic foam, is cast at

PRL using a mixture of micro and macroballoons in a polyester resin matrix. Floats of this type can be made for any depth and are simple, rugged, and leak proof. Earlier buoys using PVC tubes with end caps cemented or welded on showed occasional instances of leakage or crushing by ice contact.

A PVC tube sealed at the ends with O-ring seals is cast into the foam float and houses a 100 mW CB radio beacon transmitter built on a single PC card, antenna, batteries, a magnetic reed switch for activating the transmitter, and ballast to stabilize the buoy. The beacon switch is held open by a magnet attached to the anchor so that the beacon is activated upon call-up. The buoy is located after surfacing by steering toward the null of a hand-held loop antenna coupled to a portable CB radio receiver.

The nylon buoy tether line is pretwisted and reeled into a compact bale housed in a section of PVC pipe. The pretwisting prevents hockling when the line pays out as the buoy surfaces. The present buoy design uses 1000 lb

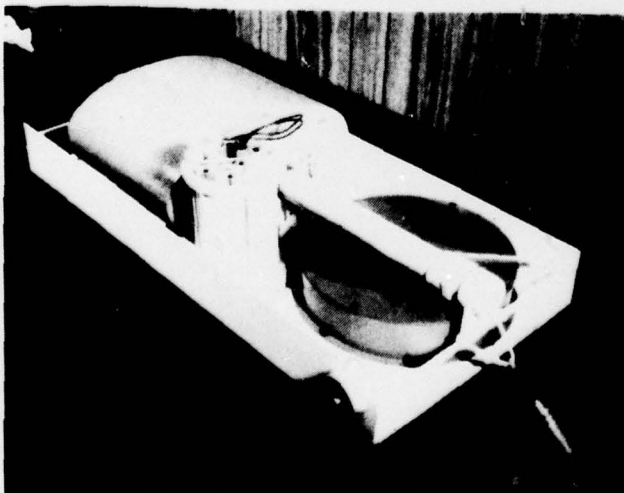

figure 1.

ACCESSION for		White Section	<input checked="" type="checkbox"/>
NTIS		Buff Section	<input type="checkbox"/>
DIC			
UNANNOUNCED JUSTIFICATION			
BY DISTRIBUTION/AVAILABILITY CODES			
Dist. Avail. and/or SPECIAL			
A	200		

test nylon anchor line. The current required to pull the buoy under is about 2 knots.

The buoys currently used are called to the surface by firing two precisely timed shots in the water. Call-up range is dictated by the size of the shots. For a buoy designed for a 200-ft depth, a call-up range of about 100 yd can normally be attained using standard blasting caps. Range can be conveniently increased by using booster sleeves on the caps. Any larger explosive can also be used. The U.S. Geological Survey has tried seismic air gun arrays for call-up but these do not work even at short range. Total energy output of the gun is greater than

that of a blasting cap but the electronics used requires the rapid rise time and high peak pressure of the explosive shock wave to trigger the circuit.

The sensor used in the call-up circuit is a bender hydrophone which consists of an aluminum disk with a piezoelectric ceramic bonded to it. A pulse from the bender triggers a timing circuit which generates a time window for receiving a second pulse. If a second pulse falls within the preset time window, the explosive bolt circuit will be activated. The combination of a narrow time window and the sharp pulses required produces a very low false alarm rate. Benders for shallow

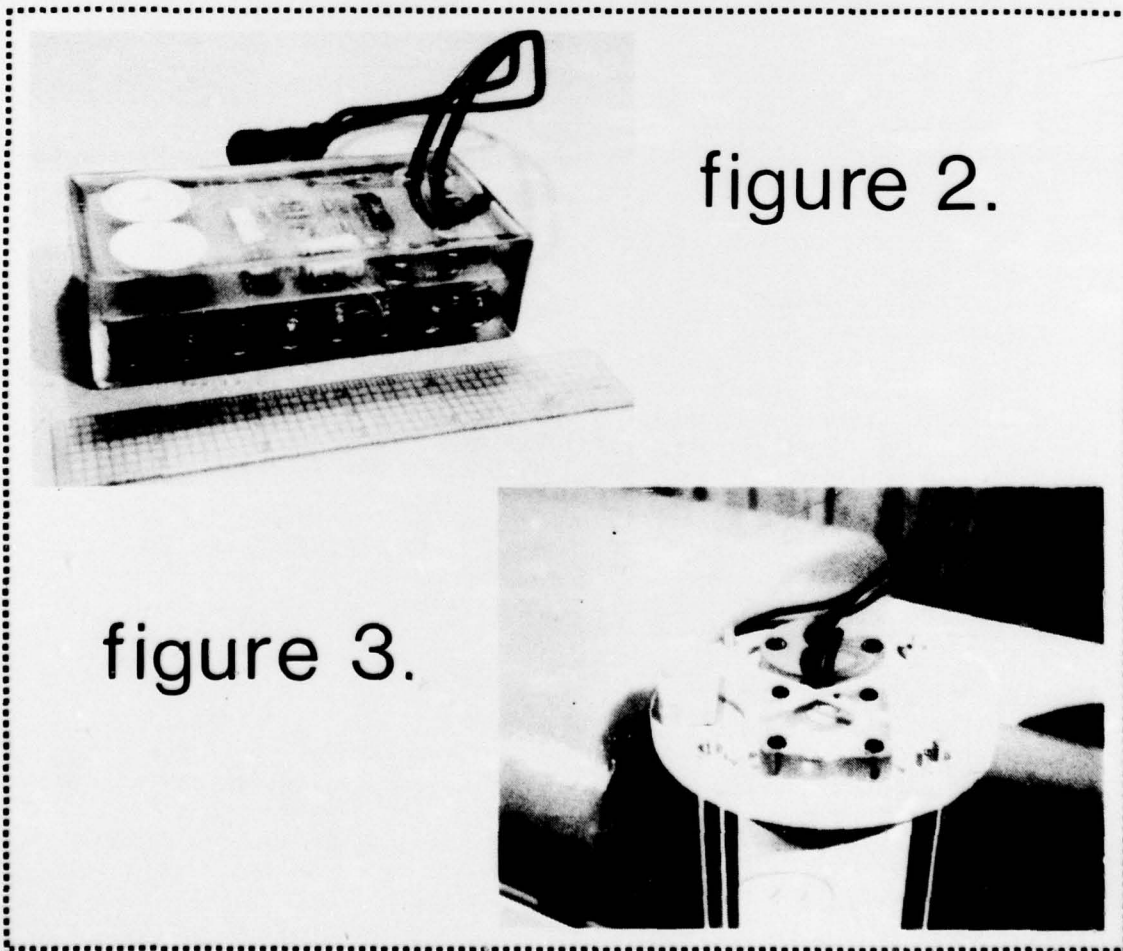

water are relatively sensitive but to prevent collapse as water depth increases, the disks must be stiffened thus reducing response. The practical depth limit for a bender with no amplifier is probably around 600 ft. Beyond this depth, to achieve reasonable call-up ranges, an amplifier is required which significantly increases power requirements.

For shallow water applications, the call-up electronics can be potted as shown in Figure 2. The batteries included in this package are sufficient for a five-year life. In more recent buoys, the electronics are housed in a chamber as shown in Figure 3. This will permit retrofitting them with a low cost system currently being completed that uses a very narrow band single tone projected from a boat unit for call up. Different center frequencies for narrow-band filters in the buoys will provide selective call-up of the buoys. This unit will permit a call-up range of several miles and will eliminate the need for explosives which are becoming increasingly difficult to obtain at remote sites. The chamber can be used in deep water, allows batteries to be easily charged, and allows the option of using redundant call-up approaches, i.e., any combination of explosive, CW or timed call-up. For deep water, cylindrical or spherical hydrophones will be substituted for benders.

FOR FURTHER INFORMATION, CONTACT:

John Anderson/Al Magnuson
Polar Research Laboratory, Inc.
123 Santa Barbara Street
Santa Barbara, CA 93101

Telephone (805) 963-1929



Al Magnuson

John Anderson

John Anderson, Vice President, Mechanical Engineering, PRL, received his BS degree in Mechanical Engineering from the Michigan Technological University in 1951 after which he joined General Motors Research Staff. He received a MS in Engineering Mechanics from Wayne State University in 1960. At GM Research Staff for 10 years he provided consulting services to the GM Divisions until 1961 when he transferred to GM's Defense Research Laboratory in Santa Barbara, Calif., where he worked until the formation of PRL in 1973. He has been involved in ocean engineering and Arctic work since 1965 specializing in design of buoy and undersea equipment.

ALBERT (AL) MAGNUSON, Vice President, Electronic Engineering, PRL, received his BS degree from Oregon State University in 1957. He worked with Phillips Petroleum and Raytheon, where he was responsible for a number of projects with emphasis on digital and servo-systems. He moved to GM's Defense Research Laboratory in 1965 where he worked until PRL was founded in 1973. Since 1965 he has specialized in design and development of acoustic signal processing systems for use in the open ocean and Arctic Seas.

explosive bolts as separation devices for pop-up instruments

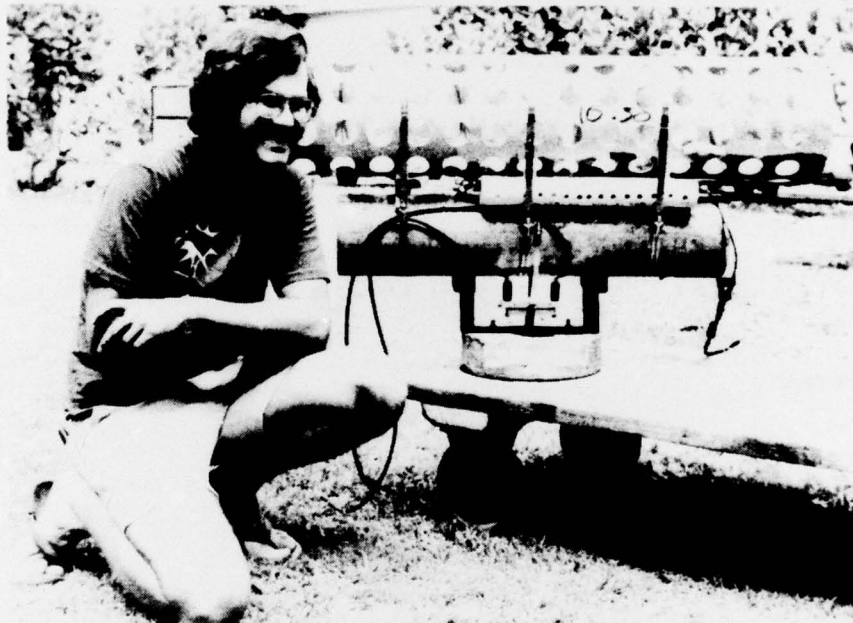

Co-Author Dave Byrne and Instrument with Explosive Bolts.

The seismic group at the Hawaii Institute of Geophysics (HIG), University of Hawaii, started development of a pop-up ocean bottom seismometer (POBS) during the spring of 1975 (Kasahara and Harvey, 1976). Explosive bolts were chosen for the ballast separation device because of their dependability, strength and low cost. The Horex #2504-13 explosive bolt (1/4-28 x 1.4") originally designed for aerospace applications was selected.

To adapt the bolt for oceanic operations, it must be waterproofed. The edges of the bolt head are roughened with #240 abrasive cloth, then cleaned with methyl ethyl ketone (MEK). The original wires are cut short and an Electro Oceanics (EO) connector (51F2M) is soldered to them. During the cutting and soldering process the bolt is placed in a thick-walled pipe. The tip of the soldering iron is grounded, the EO connector is shorted, and heat sinks are clipped to the wires on the bolt side of the solder joint. The soldered wires are looped 360° to provide stress relief and to fit the mold (Figure 1). After the soldering, the wires and bolt head

are again cleaned with MEK. A split polyethylene multiple bolt mold (Figure 1, (4)) is used to form a 1.9-cm casting (3) of Scotchcast #11 around the bolt head and leads. Scotchcast #11 is used because of its excellent potting properties. A rubber washer (5) on the bottom of the bolt seals the bottom of the mold. The mold is then assembled and a spacer (6) is placed on each bolt shaft and tightened against the mold with a nut (8). The Scotchcast is then poured into the mold and allowed to cure for 24 hours. After the bolts are removed from the mold, silastic sealant (Dow Corning 732RTV) is placed around the degreased EO pigtail and

FIGURE 1.

*Potting method
for Horex
explosive bolts.*

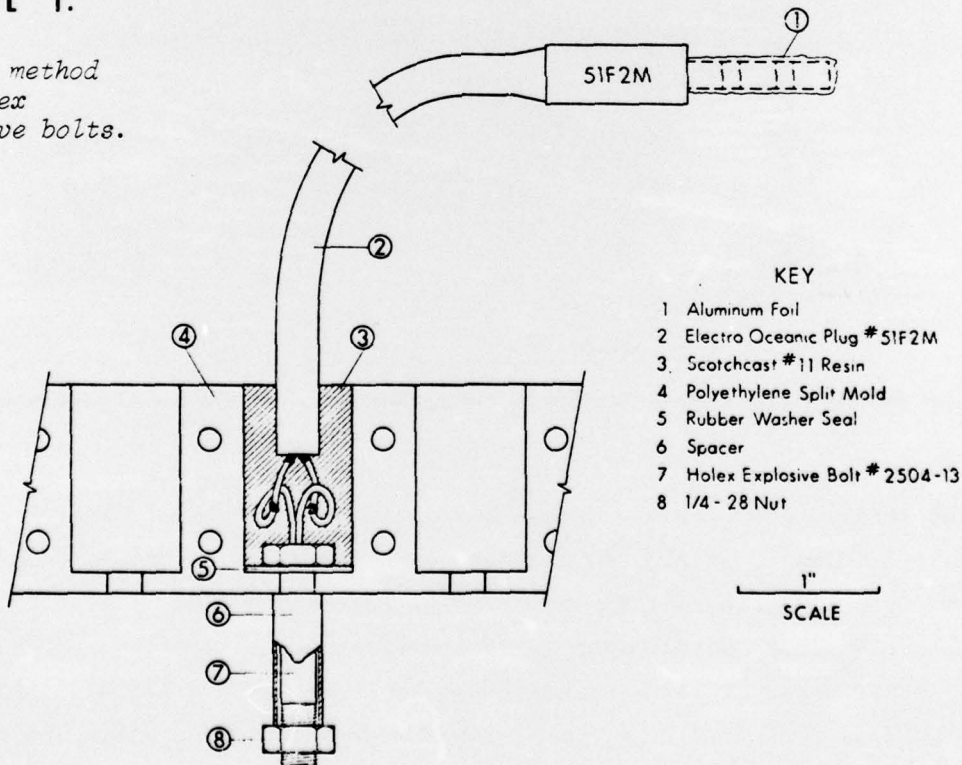

upper part of the casting. This sealant ensures that the pigtail will not separate from the Scotchcast due to movement of the pigtail or compression of the insulation with pressure. The EO connector can be reused, but if it is not available at the time of casting, the original wires can be used and the connector spliced on at a later time using standard waterproof splicing techniques. The finished bolts and mold are shown in Figure 4.

One application of the cast bolts is the double release POBS mechanism shown in Figures 2 and 3. The explosive bolts (Figure 2, (4)) are attached to the anchor coupling (1) by the fall-away lower crosspiece

(2). A half-hole is machined at each end of this piece. When either bolt fires, the lower crosspiece (2) falls away and the anchor coupling (1) is dropped.

Tension is placed on the explosive bolt by the hose clamp (7) that goes around the instrument pressure case (8) and upper crosspiece (3). Just before the explosive bolts are placed in the upper crosspiece (3) silastic sealant is applied around the lower flat of the bolt head to further ensure the watertight integrity of the bolt. Explosive safety shields are placed around the upper crosspiece. The entire release is retrieved except for the ballast, anchor coupling, and lower crosspiece.

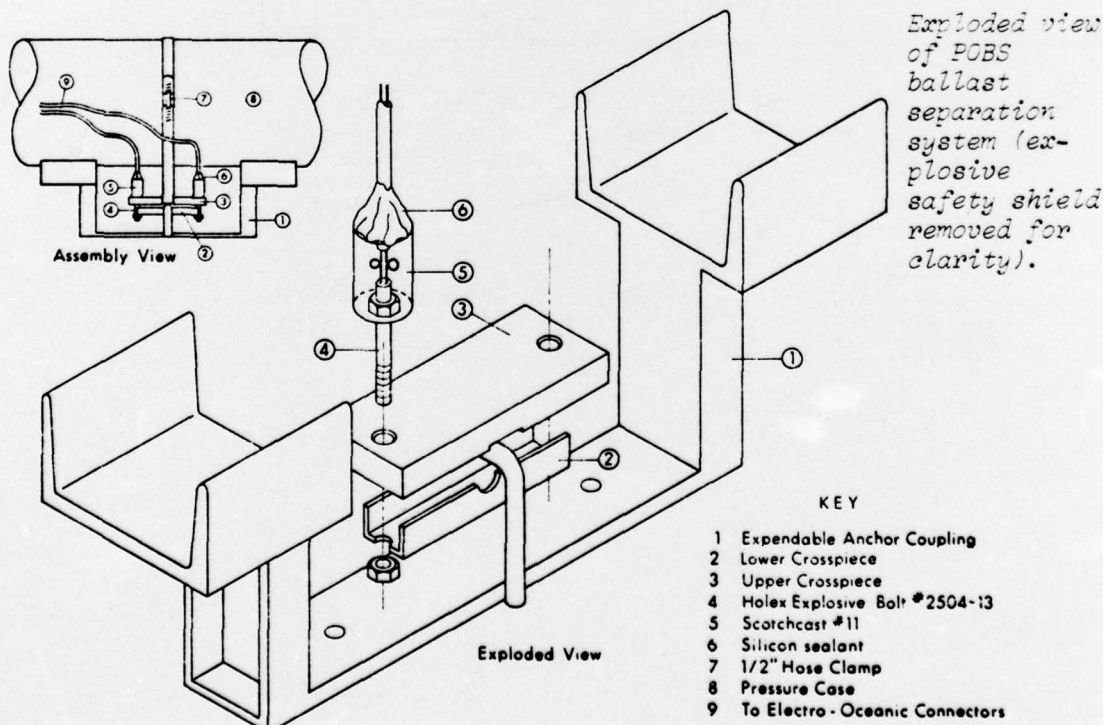

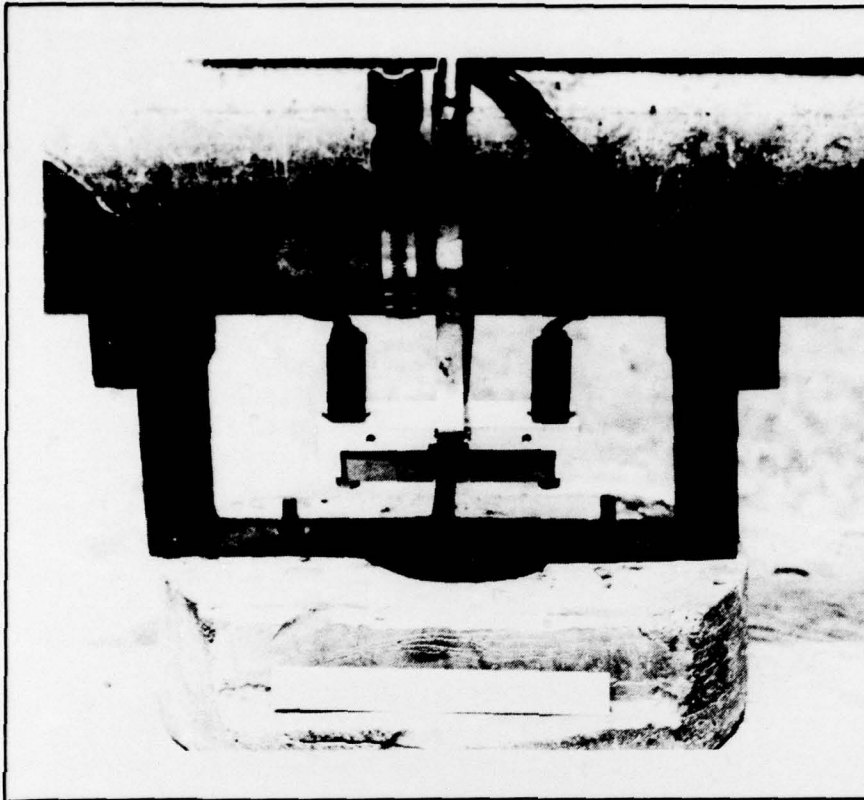

FIGURE 3.

POBS anchor assembly attached to pressure case with 100-lb free fall core weight as ballast (explosive safety shields removed for clarity).

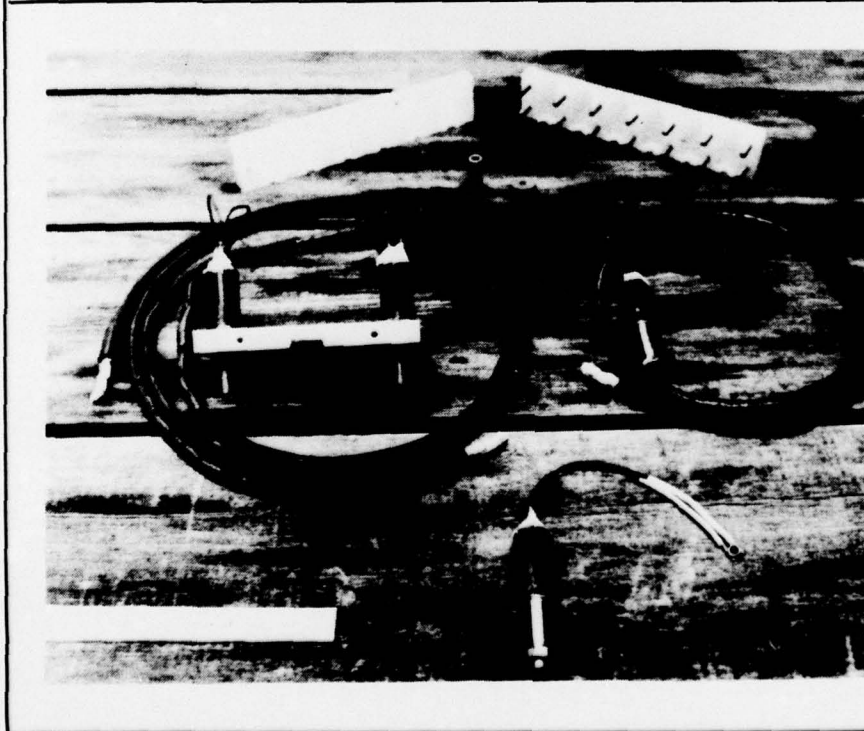

FIGURE 4.

Upper left to right: Multiple polyethylene split-mold, spacer, rubber washer, explosive bolts insulated in upper cross-piece, explosive bolt with EO connector, explosive bolt with original wires.

The "All-Fire" current of the bolt is greater than 3.5 A, with a recommended current of 10 A or more. The "No-Fire" current is less than 1.0 A, although the bolt resistance is only 0.2 ohm. The release circuitry in the present HIG POBS (Sutton et al., in press) consists of two independent firing circuits. The primary circuit is driven by the master clock of the POBS. The information from the POBS clock counter is compared to the settings of the preset primary release time select switches. When the counter content equals that selected on the switch, an SCR is triggered and the primary release bolt is effectively shorted across four previously unused alkaline "D" cells connected in series. The 0.2 ohms resistance of the bolt, the resistance of the EO connector, the voltage drop across the SCR (1 V at 5 A) and the internal resistance of the fresh alkaline "D" cell (0.15 ohms at 0°C) combine to provide 5.6 A of bolt firing current 40 percent greater than the guaranteed "All-Fire" current of the bolt.

A completely independent secondary release uses a simple 18.641-kHz crystal oscillator and divider stage to produce 1 pulse per hour. This pulse advances a 3-decade BCD counter. The content of this counter (000-999) is compared with the secondary release time select switches and when equal, the secondary release SCR is fired. This applies 6 V (different from the primary release 6 V) across the secondary release explosive bolt.

The reliability of the explosive bolts has been excellent. The only two confirmed instances in which the explosive bolts failed to fire when they received the proper firing current occurred when quality

control was inadequate during the potting procedure. One instrument loss may be attributed to this factor. Other instrument losses (four instruments) were almost certainly due to failure of the radio beacons, and failure of the ship to be on station at the time.

Per deployment, the cost is approximately \$95.20 for expendable supplies, which include two potted explosive bolts, a portion of the reuseable connector, anchor coupling, ballast, hardware, lower crosspiece and batteries.

This work was supported by the Office of Naval Research.



References:

- (1) J. Kasahara and R. Harvey, "Ocean Bottom Seismometer Study of the Kuril Trench Area," *Hawaii Inst. Geophysics Report*, HIG-76-9, 1976, 24 pp.
- (2) G. Sutton, J. Kasahara, W. Ichinose, and D. Byrne, "Ocean Bottom Seismograph Development at Hawaii Institute of Geophysics," *Marine Geophysical Researches*, in press.

FOR FURTHER INFORMATION, CONTACT:

David A. Byrne or Robert C. Mitiguy
Hawaii Institute of Geophysics
University of Hawaii, Manoa
2525 Correa Road
Honolulu, Hawaii 96822

Telephone: (808) 948-8910
948-8711



(Picture on page 5).
David A. Byrne is project coordinator for the OBS effort at the Hawaii Institute of Geophysics. He received an Associate degree in Electrical Technology from the State University of New York at Morrisville and a B.S. in geology and geophysics from the University of Hawaii. He has been involved in design, development, and testing of ocean equipment and instrumentation since 1972.

Robert Mitiguy has been designing instruments for the Hawaii Institute of Geophysics for the past eight years. Previously he was a design engineer for Hazeltine Corporation in Braintree, Massachusetts, designing submarine acoustic communications and sonar systems. He is presently involved with the mechanical design of the Hawaii Institute of Geophysics ocean bottom seismometer systems at their prototype lab facility.

Table Of Contents

Page	Article	Author
1	CUBE--A Simple, Low Cost Call-Up Buoy; and	Anderson/Magnuson
5	Explosive Bolts As Separation Devices For Pop-Up Instruments	Byrne/Mitiguy

MEMORANDUM

TO: EXPOSURE Readers
FROM: Rod Mesecar, Editor

Your assistance is needed to update the mail list for the EXPOSURE newsletter. Please take a few minutes, while your attention is directed to the request, to fill out the form on this page and return it for my files. If the form is not returned by April 1977, I will assume the EXPOSURE newsletter is not reaching you and I will adjust the mail list accordingly. } note!

When properly folded, the reverse side of this page is a self-addressed envelope--please staple, stamp, and mail it.

Thank you for your cooperation.



Comments: _____

-
- We (I) wish to remain on your mail list.
 Please delete our (my) name from your mail list.

Please Print:

NAME _____
ADDRESS _____

ZIP _____
TELEPHONE (area code) _____

Please add the following name(s) to the mail list: