

AD-A035 514

GERMANTOWN LABS INC PHILADELPHIA PA
CHEMICAL RELEASE PAYLOADS FOR THE WINTER ANOMALY PROGRAM (1976)--ETC(U)
OCT 76 C S STOKES, W J MURPHY, E W SMITH F19628-76-C-0056

F/G 4/1

AFGL-TR-76-0312

NL

UNCLASSIFIED

| OF |
AD
A035514



END
DATE
FILMED
3-77

FG.

12

ADA035514

AFGL-TR-76-0312

CHEMICAL RELEASE PAYLOADS FOR
THE WINTER ANOMALY PROGRAM (1976),
ICE CAP PROGRAM (1976) AND
OPERATION HARSES (1976)

Charles S. Stokes
William J. Murphy
Edward W. Smith

Germantown Laboratories, Inc.
4150 Henry Avenue
Philadelphia, Pa. 19144

30 October 1976

Final Report for Period - 1 October 1975 to 30 September 1976

Approved for public release; distribution unlimited

**COPY AVAILABLE TO DDC DOES NOT
PERMIT FULLY LEGIBLE PRODUCTION**

AIR FORCE GEOPHYSICS LABORATORY
AIR FORCE SYSTEMS COMMAND
UNITED STATES AIR FORCE
HANSCOM AFB, MASSACHUSETTS 01731

DDC
RECEIVED
FEB 14 1977
D
[Handwritten signature]

1473

Qualified requestors may obtain additional copies from the Defense Documentation Center. All others should apply to the National Technical Information Service.

ACKNOWLEDGEMENT

The authors wish to thank Mr. W. Kenneth Vickery and Mr. Martly F. Mellow, both of Air Force Geophysics Laboratory for their direction and help on the design, assembly and field service support to the programs reported herein.

TABLE OF CONTENTS

	<u>PAGE</u>
I. Winter Anomaly Program (1976)	6
II. Ice Cap Program (1976)	12
III. Operation Harses (1976)	12

INTRODUCTION

This report covers the work performed in support of the chemical payloads for the Winter Anomaly Program, January 1976 launch series from NASA Wallops Station, Virginia, the Ice Cap program spring 1976 launch series and the two launch series of May 1976 and July 1976 for Operation Harses from White Sands Missile Range, New Mexico.

These operations included design, fabrication, assembly and launch services for chemical payloads containing trimethyl aluminum and/or titanium tetrachloride-methanol/water.

ACCESSION for	
DTIS	White Section <input checked="" type="checkbox"/>
GRS	Buff Section <input type="checkbox"/>
CHARGENCED	<input type="checkbox"/>
JUSTIFICATION.....	
BY.....	
RESTRICTION/AVAILABILITY CODES	
REF. #, OR SPECIAL	
A	

D D C
RECEIVED
 FEB 14 1977
RECEIVED
 D

I. Winter Anomaly Program

A. Program

The purpose of the program was to measure the transport parameters in the mesosphere and lower thermosphere during a period of anomalous radiowave absorption. (1)

B. Description of Experiment

A rocket-borne titanium tetrachloride ($TiCl_4$) tracer was deposited in the altitude region 70 to 90 km, and a trimethyl-aluminum (TMA) vapor trail continued from 90 to 130 km altitude. Optical observations of these trace element trails resulted in (1) the winds from 70 to 130 km, (2) the turbulent parameters--rate of occurrence and intensity of turbulence below the turbopause and (3) the molecular parameters--diffusion coefficients and density above the turbopause. Two dusk flights were planned, one on a standard day and one on an anomalous day.

C. Payload Description

A Schematic of the payload is shown in Figure 1. It contains 2 piston tanks for the release of titanium tetrachloride (FM) and 36% water/64% methanol mixture (WM). The piston tanks are charged with 68 pounds of FM and 59 pounds of WM. They are released simultaneously by appropriate valving with the piston tank pressurized to 100 psig nitrogen. The nose cone contains a small piston tank with appropriate plumbing for releasing 4.5 pounds of trimethyl aluminum (TMA).

Figure 2 shows the payload dimensions and other data and Figure 3 gives the chemical release description. This type of payload has been previously flown except for the incorporation of the TMA release system in the nose cone. Two payloads were provided by AFGL for the launch series.

D. Programmer Description

The FM/WM module uses a type 12-308 programmer which is shown schematically in Figure 4. Figure 5 gives the schematic of the programmer, type 5-107, which is used for the TMA module.

E. Launch Operations

The two empty chemical payloads A08.608-1 and A08.608-2 were received from AFGL in early December 1975. The payloads were identical. The cylindrical section contained two piston tanks for the release of titanium tetrachloride (FM) and 36% water/64% methanol mixture (WM). The nose cone contained a small piston tank for releasing 3.25 pounds of trimethyl aluminum (TMA)

DYNAMICS PAYLOAD FOR D&E REGION MOTIONS

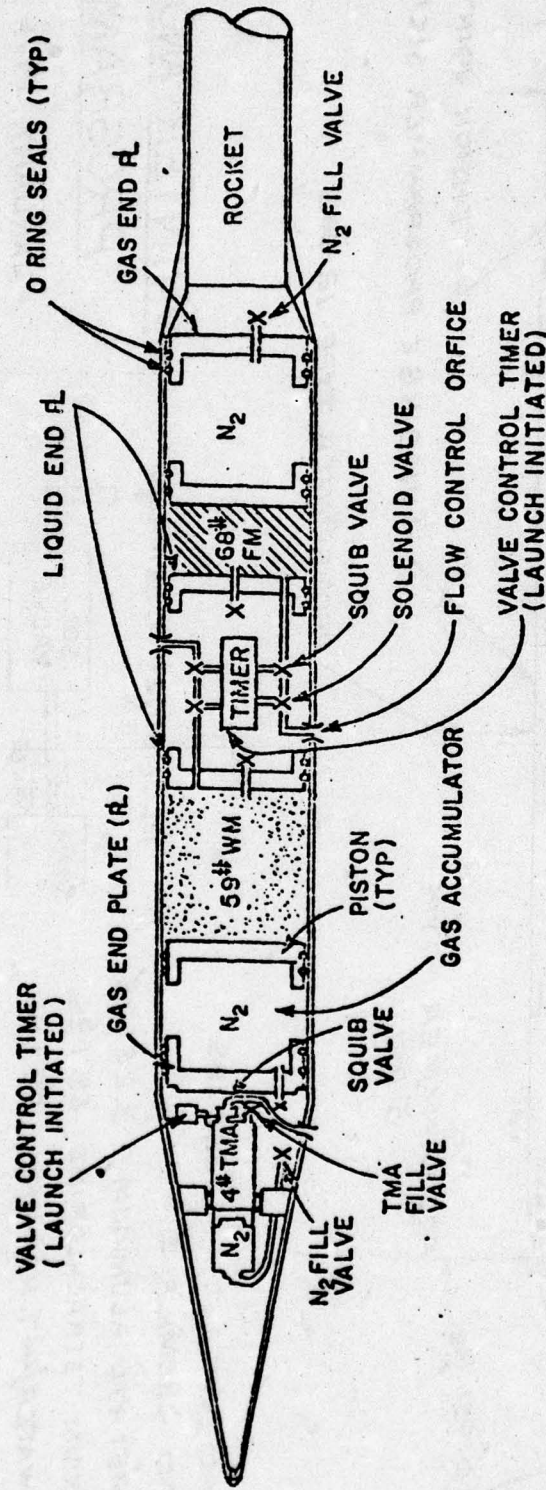
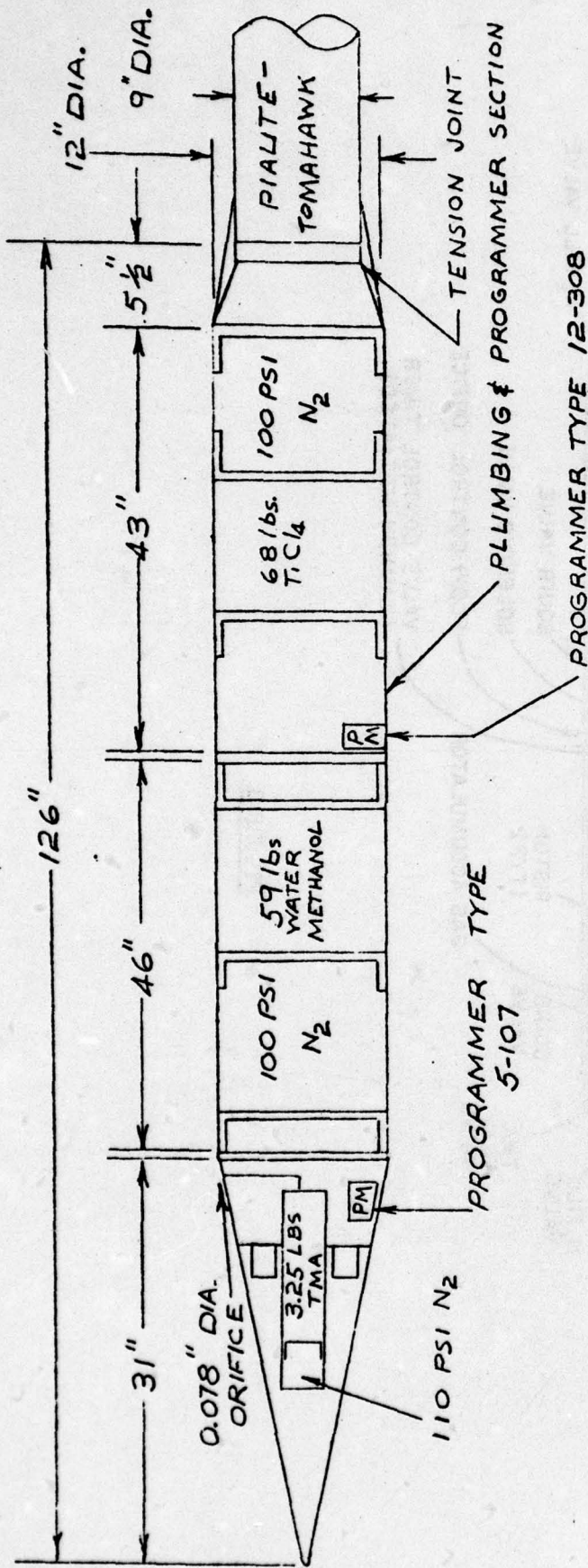

FIGURE 1



PAYLOAD WT. 350 LBS

PAYLOAD CHEMICALS

TRIMETHYL ALUMINUM 3.25 LBS.

TITANIUM TETRACHLORIDE 68 LBS.

36% WATER/64% METHANOL 59 LBS.

WINTER ANOMALY
PROGRAM

JANUARY 1976

PAYLOAD NOS.

A 08.608-1

A 08.608-2

PLUMBING SCHEMATIC

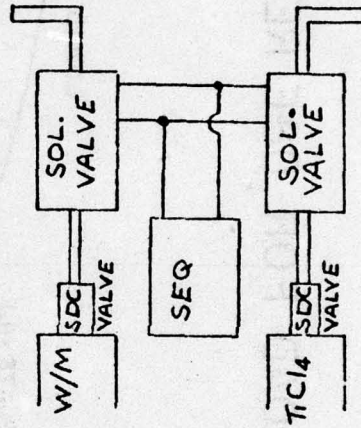

FIGURE 2

WINTER ANOMALY PROGRAM

RELEASE SEQUENCE

$TiCl_4$ - CH_3OH/H_2O PUFF RELEASES
 3 EACH 4 SEC DURATION PUFFS
 8.5 lbs $TiCl_4$, 7.4 lbs WM PER PUFF
 8 SEC DUTY CYCLE

 TMA TRAIL
 TMA WEIGHT 3.25 lbs
 TMA ORIFICE .078"
 RELEASE DURATION 50 SEC
 RELEASE RATE 35 gm./SEC
 TANK PRESSURE 110PSIA

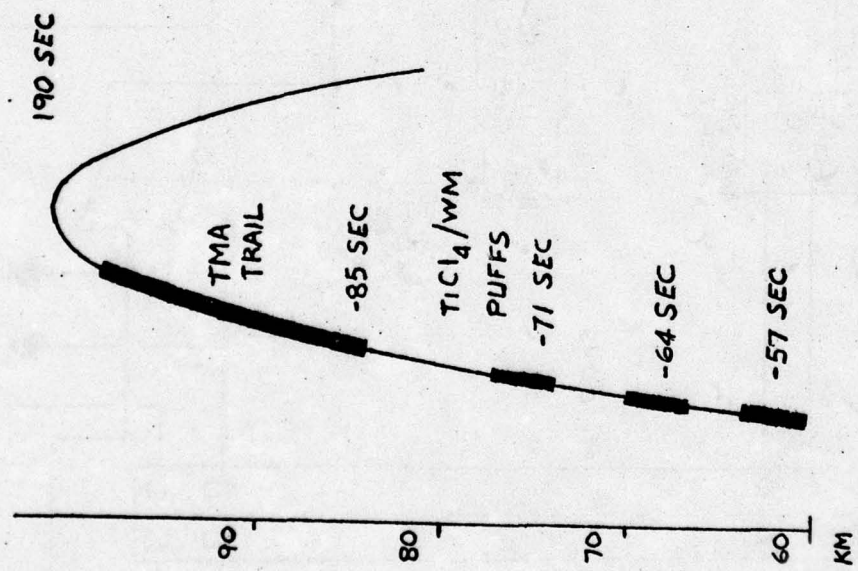
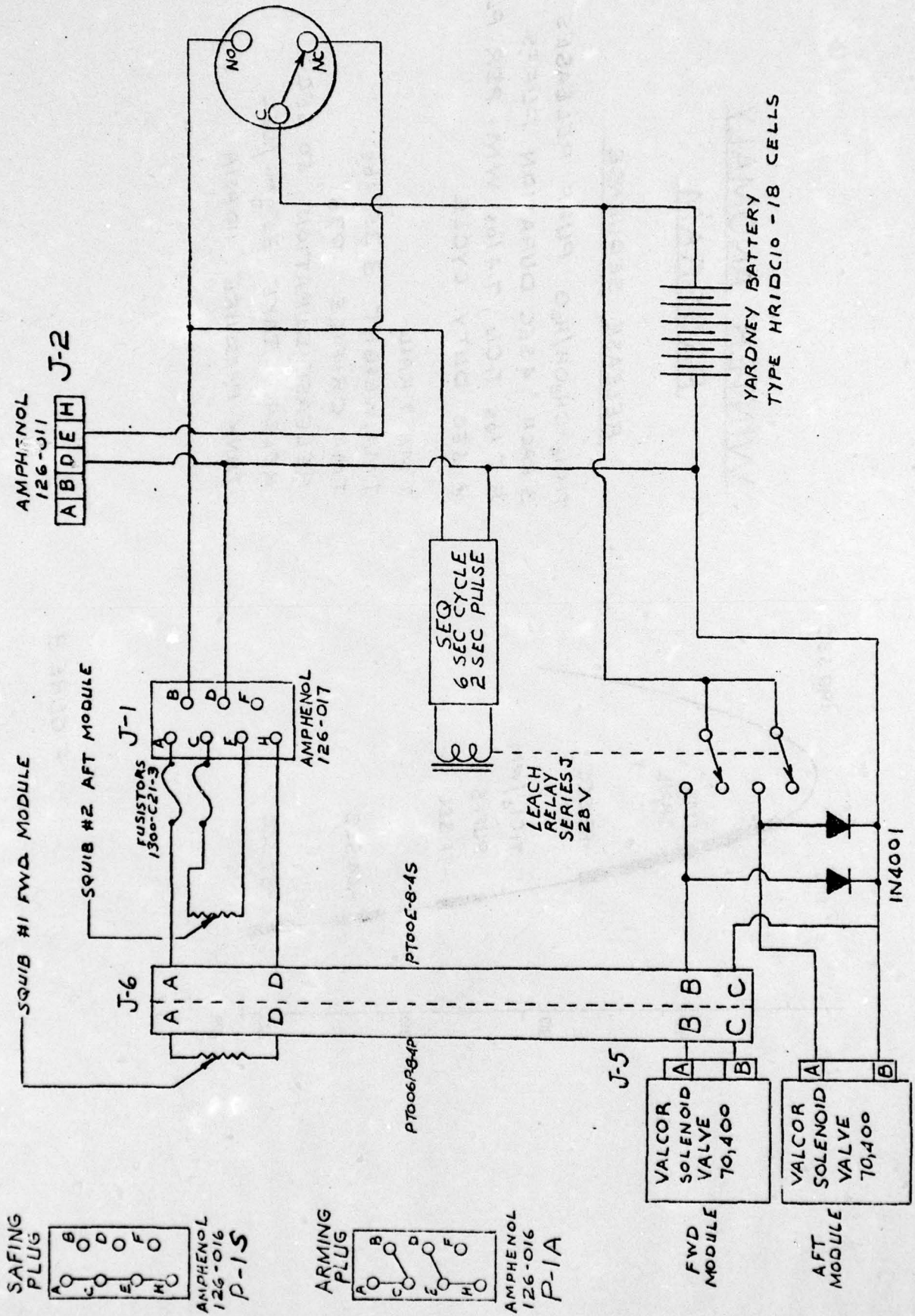
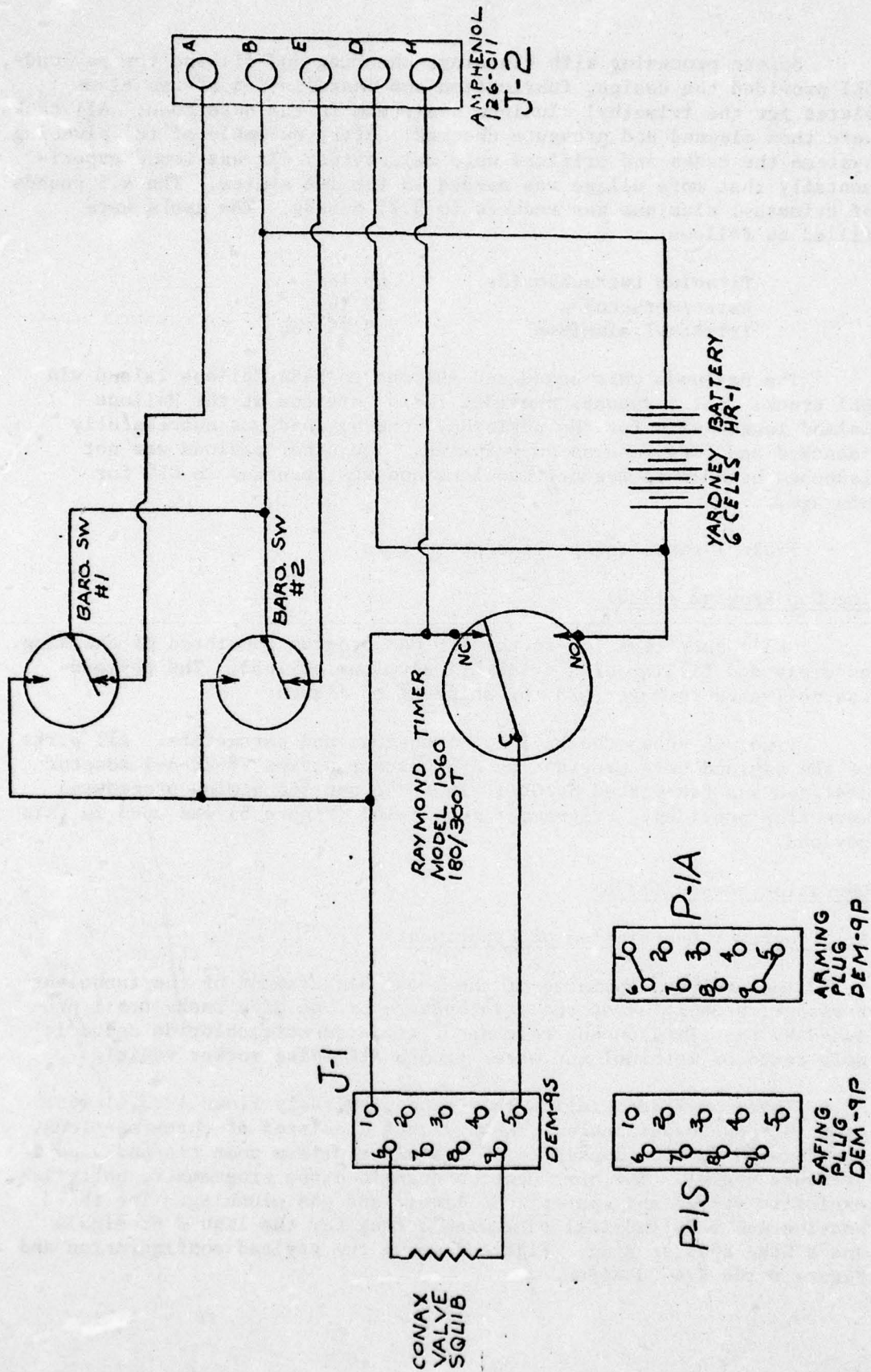

FIGURE 3



PROGRAMMER TYPE 12-308
FIGURE 4

MS 3106B10SL-4S/P



PROGRAMMER TYPE 5-107 SINGLE SQUIB PYRO CIRCUIT

FIGURE 5

Before proceeding with cleaning, checking and filling the payloads, GLI provided the design, fabrication and installation of two clamp plates for the trimethyl aluminum canisters in the nose ne. All tanks were then cleaned and pressure checked. After assembly of the plumbing systems the tanks and orifices were calibrated. It was found experimentally that more ullage was needed in the TMA system. The 4.5 pounds of trimethyl aluminum was reduced to 3.25 pounds. The tanks were filled as follows:

Titanium tetrachloride	68 lbs.
Water/methanol	59 lbs.
Trimethyl aluminum	3.25 lbs.

The payloads were boxed and shipped to NASA Wallops Island via GLI truck. GLI personnel provided field services at the Wallops Island launch site for the payloads. One payload was successfully launched and performed as anticipated. The other payload was not launched because of weather problems and was returned to GLU for storage.

Table I gives the payload parameters.

II. Ice Cap Program (1976)

GLI's participation in the ICE CAP program consisted of checking, assembly and filling of a trimethyl aluminum payload. The payload was delivered to Dover AFB for shipment to Alaska.

Figure 6 shows the payload dimensions and parameters. All parts of the payload were provided by AFGL except a type 28-22-A-1 adaptor designed and fabricated by GLI. The checkout and aiming procedures were also provided. Programmer type 5-107 (Figure 5) was used in this payload.

III. Operation Harses (1976)

A. Program & Description of Experiment

The program consisted of the local measurement of the turbulent transport properties of the stratosphere by use of a smoke trail produced by the simultaneous release of titanium tetrachloride and a 1:1 mole ratio of methanol and water from a Nike-Nike rocket vehicle.

Three payloads similar to a type previously flown (2,3,4) were used in these experiments. The payloads consisted of three sections. The forward section consisted of a small aluminum nose tip and a conical pressure vessel. The next section contained the programmer, batteries, explosive valves and appropriate liquid and gas plumbing. The third section was a cylindrical tank with a tank for the liquid chemicals and a Nike adapter ring. Figure 7 shows the payload configuration and Figure 8 the flow diagram.

TABLE I
WINTER ANOMALY PROGRAM - PAYLOAD DATA

Payload No.	A08.608-1	A08.608-2
Vehicle Type	Paiute Tomahawk	
<u>Module No. 1</u>	Trimethyl Aluminum	
Position	Nose Cone	
Chemical Weight (lbs)	3.25	
Programmer Type	5-107	
Module Pressure (PSIA)	110	
<u>Module No. 2</u>	Water-Methanol	
Position	Forward	
Chemical Weight (lbs)	59	
Module Pressure (PSIA)	100	
<u>Module No. 3</u>	Titanium Tetrachloride	
Position	Aft	
Chemical Weight (lbs)	68	
Module Pressure (PSIA)	100	
Programmer Type	12-308	
Total Payload Weight (lbs)	354	354
Total Payload Length (in.)	126	126
Center of Gravity from Aft Joint (in.)	$46\frac{3}{4}$	47½
Launch Date	Jan. 23, 1976	Not Launched
Remarks	Successful	Weather Problem Returned to GLI

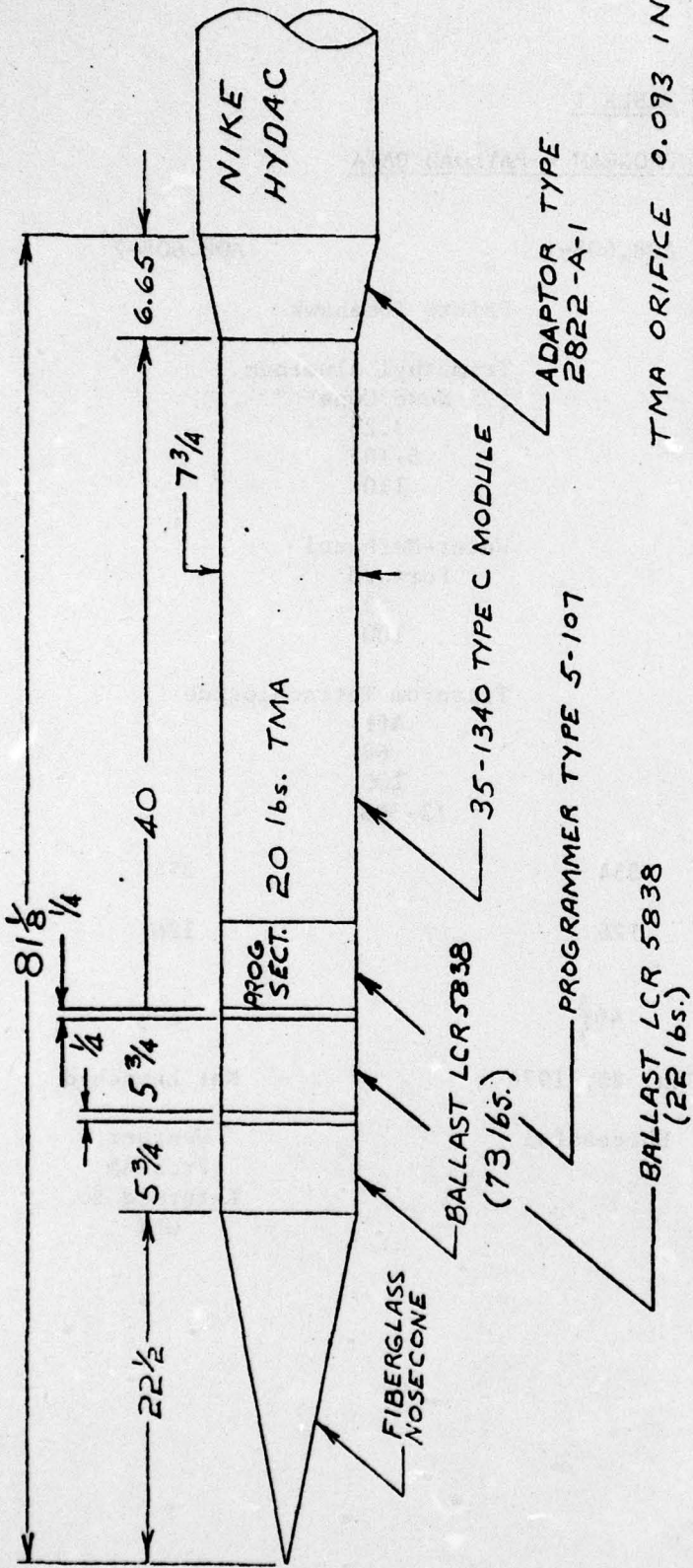

TMA ORIFICE 0.093 IN
 TANK PRESSURE 125 PSIA
 RELEASE TIME 118 SECONDS
 TIMER SET 63.5 SECONDS

TOTAL WEIGHT - 160 lbs
 CHEMICAL - TRIMETHYL ALUMINUM, 20 lbs.
 PROGRAMMER TYPE - 5-107

ICE CAP 76

FIGURE 6

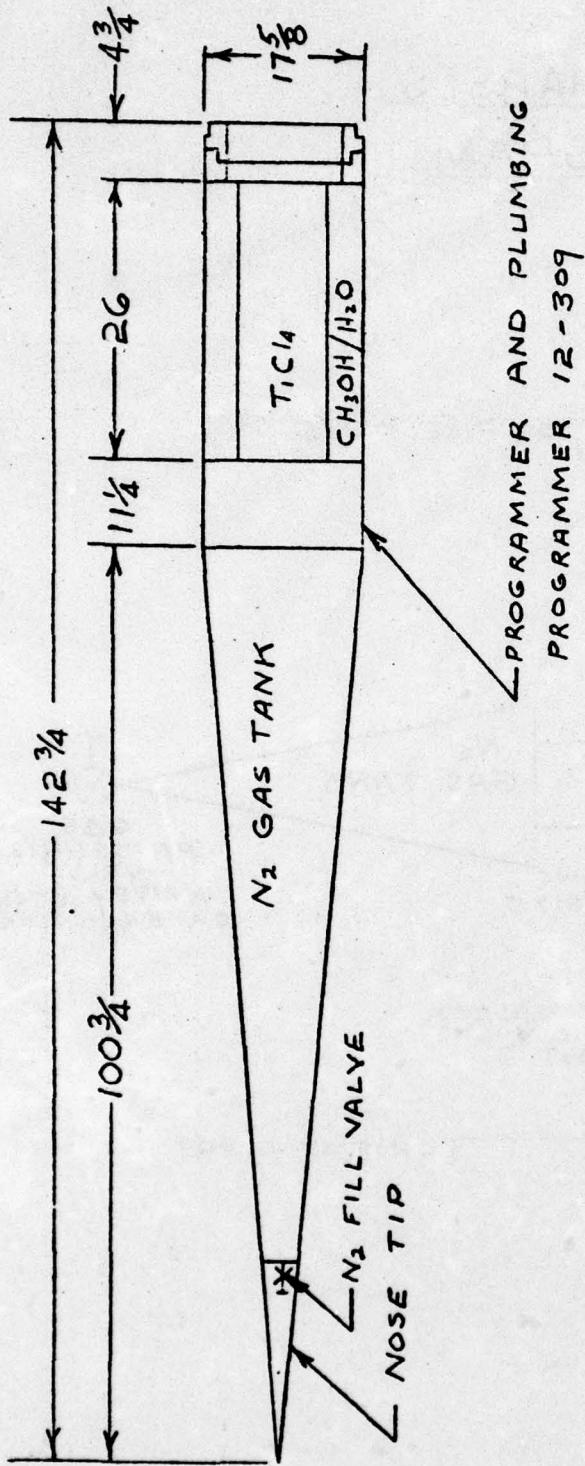

OPERATION HARSES 1976

PAYLOAD No 023
024
025

PAYLOAD WT 548 lbs

PAYLOAD CHEMICALS

TITANIUM TETRACHLORIDE 135 lbs

36% WATER / 64% METHANOL 118 lbs

FIGURE 7

OPERATION HARSES
FLOW DIAGRAM

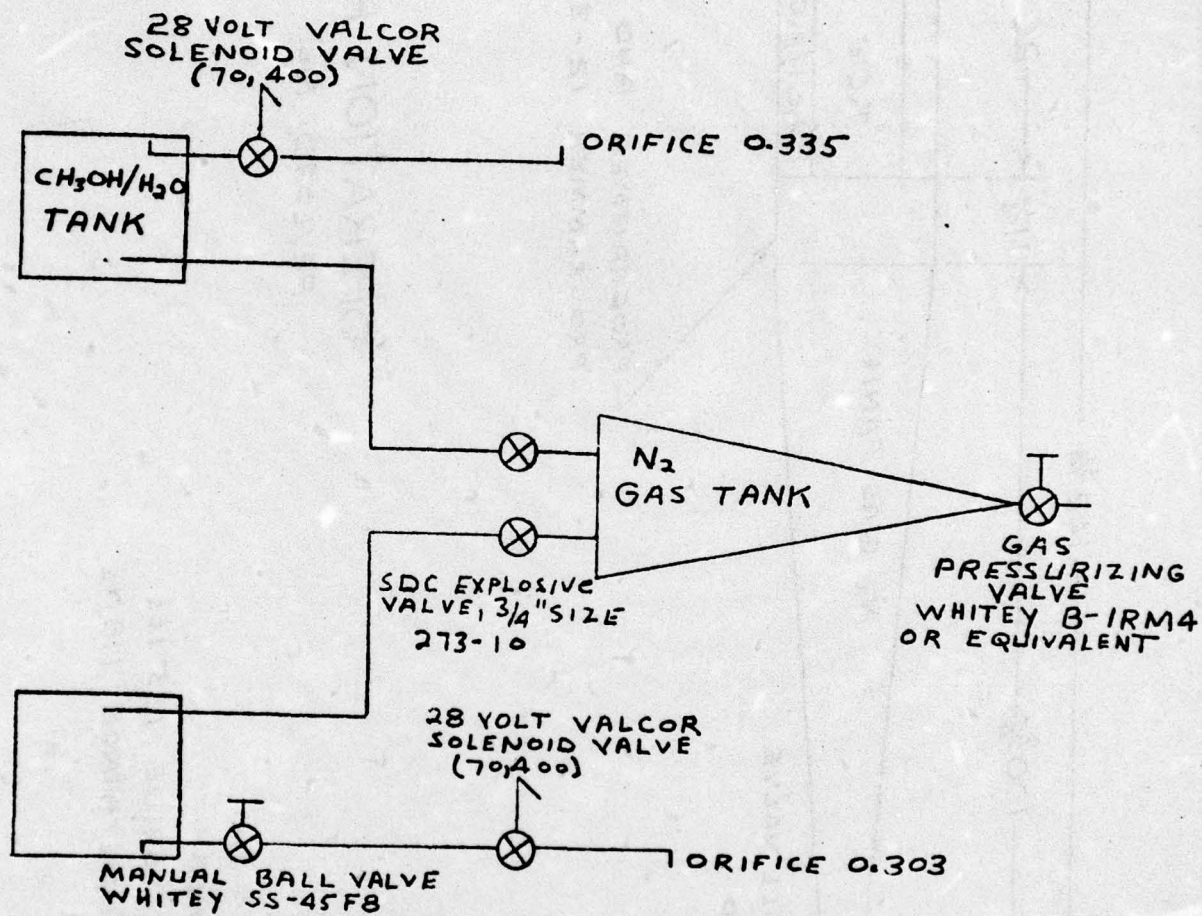

FIGURE 8

The release system used for these payloads was changed from the previously flown type to permit eight separate trail releases. This was accomplished by using 28 volt solenoid valves (1 inch size) on each tank for chemical release. The tanks were pressurized from the nose cone pressure tank through two explosive valves.

Table II lists the programmer release times and Table III, the payload parameters. A schematic of the programmer (type 12-309) is shown in Figure 9.

B. Launch Operations

The payloads were received by GLI unassembled. Plumbing buildup and component assembly was accomplished before shipping to White Sands Missile Range (WSMR). When the payloads arrived at WSMR the tankage was flushed again with dry nitrogen and pressure checked.

A 125 lb. container of $TiCl_4$ was set up out of doors with appropriate filling and pressure lines ($\frac{1}{4}$ " copper tubing) and attached to the fill fittings of the tank of the payload. The $TiCl_4$ was pressed into the payload. The operation took approximately 1 hour to fill the tank.

A 1:1 mole mixture of methanol-water was made up in a filling tank of approximately 6 gallon capacity. The mixture was then pressurized into the tank of the payload.

While tankage was being filled other personnel were making final programmer adjustments, and final electrical connections.

The payload was then taken to the launch area and mated to the Nike. The payload was pressurized on the launch rail as part of the flight checkout procedures.

One payload was shipped to WSMR in April 1976 for a test launch of the NIKE-NIKE smoke release system since the payload was larger than the previous type (4) and had never been flown on the NIKE-NIKE vehicle. The flight test took place on May 20, 1976 with a successful launch and satisfactory payload performance.

The remaining two payloads were shipped to WSMR on June 1976 for a July 1976 launch series. The No. 024 smoke payload was successfully launched on July 28, 1976 with satisfactory payload performance. The No. 25 payload was not launched due to weather problems and was subsequently returned to GLI, cleaned and stored for future use.

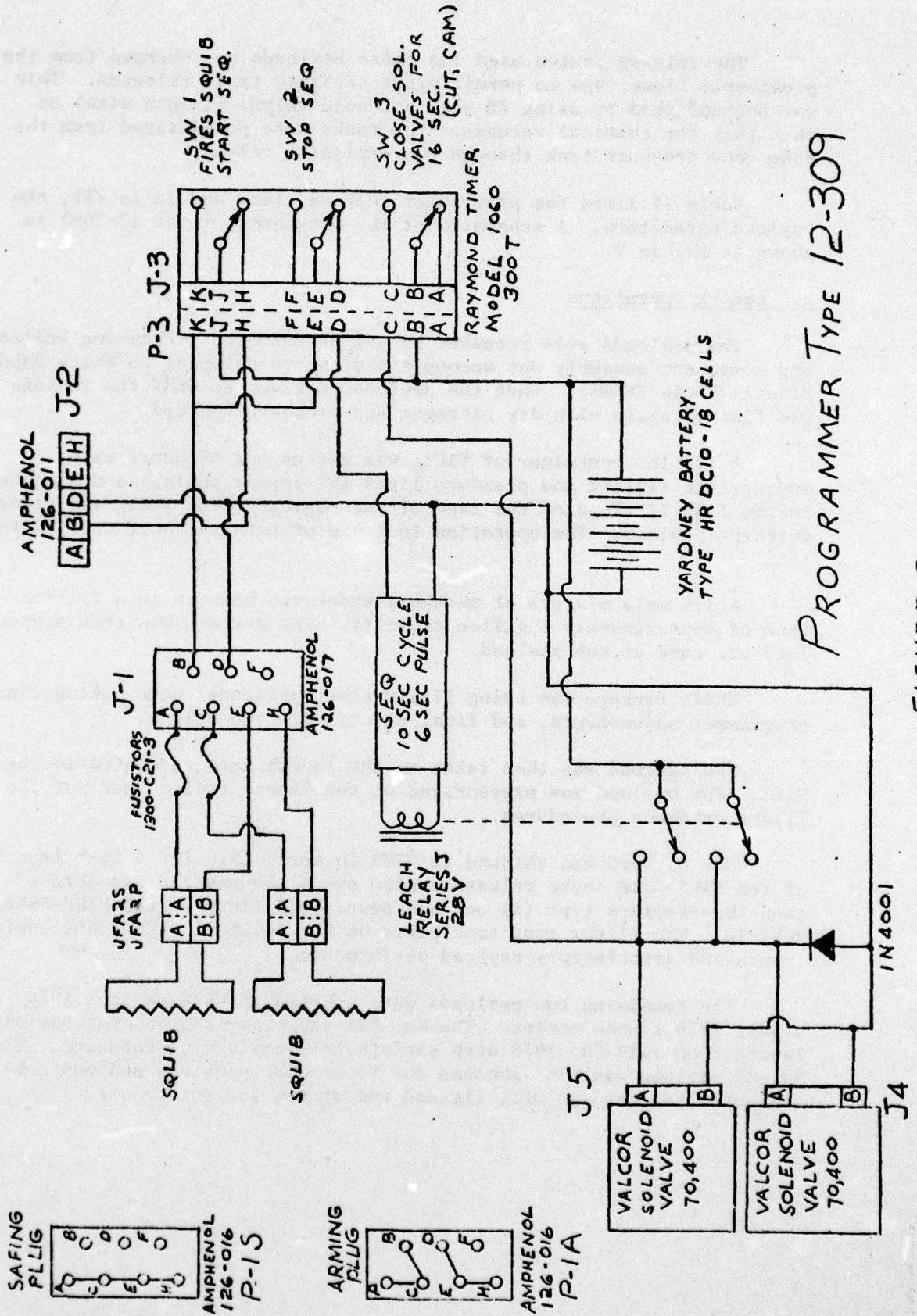

PROGRAMMER TYPE 12-309

FIGURE 9

TABLE II
PROGRAMMER TIMING - TRAIL RELEASE
NIKE-NIKE SMOKE SYSTEM

Titanium Tetrachloride Orifice	0.303 in.
Tank Pressure	100 psia
Air Flow Rate	2.28 lbs/sec.

Methanol/Water Orifice	0.335 in.
Tank Pressure	100 psia
Air Flow Rate	2.00 lbs/sec.

<u>Trail No.</u>	<u>Start Second</u>	<u>End Second</u>
1	30	36
2	40	46
3	50	56
4	60	66
5	70	76
6	80	86
7	90	96
8	105	120

Programmer type 12-309

TABLE III
PAYLOAD PARAMETERS, NIKE-NIKE SMOKE SYSTEM

Payload No.	023	024	025
Vehicle	NIKE-NIKE	NIKE-NIKE	NIKE-NIKE
CH ₃ OH/H ₂ O Aft Tank			
Wt. Chem. (lbs)	118	118	118
Orifice (in.)	0.335	0.335	0.335
TiCl ₄ Fwd Tank			
Wt. Chem (lbs)	135	135	135
Orifice (in.)	0.303	0.303	0.303
Nose Cone			
Pressure (PSIA)	100	100	100
Total Payload Wt. (lbs)	548	547	547
CG, in. from Nike Joint	23 $\frac{1}{4}$	23 $\frac{1}{2}$	23 $\frac{3}{4}$
Launch Date	May 20, 1976	July 28, 1976	Not Launched
Remarks	Successful Apogee 198K ft.	Successful	Weather Problem Shipped back to GLI

C. Design of a 685 Pound Smoke Release Payload

Based on the flights of the two smoke release payloads described above and data generated from the flight tests, AFGL requested an enlarged design weighing 685 pounds of the above type be investigated. Figure 10 shows schematically the redesigned smoke payload. A complete set of engineering drawings for this design were transmitted to AFGL.

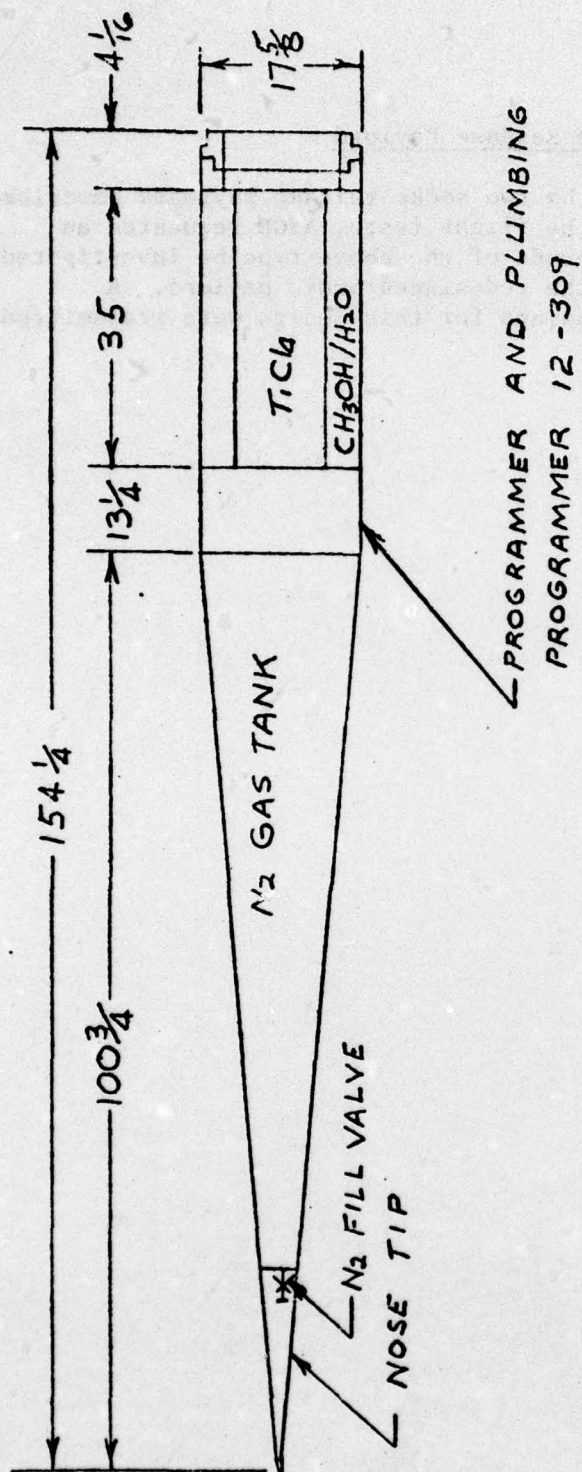

NIKE-NIKE SMOKE
685 lb PAYLOAD

PAYLOAD WT 685 lbs
 PAYLOAD CHEMICALS
 TITANIUM TETRACHLORIDE 184 1/3 lbs
 36% WATER / 64% METHANOL 161 1/3 lbs.

FIGURE 10

REFERENCES

- (1) Anon., AFCRL Dynamics Experiment for the Winter Anomaly Program, Wallops Island, Va., January 1976.
- (2) Stokes, C. S., Murphy, W. J. and Smith, E. W., Experimental and Flight Evaluation of the Titanium Tetrachloride-Water Methanol System for the Production of Smoke Trails, Final Report, Germantown Laboratories, Inc., AFCRL-TR-74-0496, June 30, 1974.
- (3) Vickery, W. K., Techniques for Depositing Visible Smoke Trails in the Stratosphere for Measurement of Winds and Turbulence, AFCRL-TR-75-0221, April 21, 1975.
- (4) Stokes, C. S., Murphy, W. J., and Smith, E. W., Chemical Release Payloads for Operation Post Aladdin 74, Operation Aeolus and Operation Harses (Smoke II), Final Report, Germantown Laboratories, Inc., AFCRL-TR-75-0625, August 31, 1975