

AD-A035 574

COAST GUARD RESEARCH AND DEVELOPMENT CENTER GROTON CONN F/G 13/10
INVESTIGATION OF RECREATIONAL BOAT STEERING AND CONTROL SYSTEMS--ETC(U)
APR 76 J R TAYLOR
COR/DC-8/76

USCG-D-119-76

NL

UNCLASSIFIED

1 of 2
AD
A035574



Report No. CG-D-119-76

J
JK

ADA035574

**INVESTIGATION OF RECREATIONAL BOAT
STEERING AND CONTROL SYSTEMS**

**John R. Taylor
USCG Research and Development Center
Avery Point
Groton, CT 06340**



April 1976

Final Report

Document is available to the public through the
National Technical Information Service,
Springfield, Virginia 22161

**DDC
RECEIVED
FEB 14 1977**

Prepared for

**DEPARTMENT OF TRANSPORTATION
UNITED STATES COAST GUARD
Office of Research and Development
Washington, D.C. 20590**

JR

**COPY AVAILABLE TO DDC DOES NOT
PERMIT FULLY LEGIBLE PRODUCTION**

NOTICE

This document is disseminated under the sponsorship of the Department of Transportation in the interest of information exchange. The United States Government assumes no liability for its contents or use thereof.

The United States Government does not endorse products or manufacturers. Trade or manufacturers' names appear herein solely because they are considered essential to the object of this report.

The contents of this report reflect the views of the Coast Guard Research and Development Center, which is responsible for the facts and accuracy of data presented. This report does not constitute a standard, specification or regulation.

1. Report No. 18 USC6 CG-D-119-76	2. Government Accession No.	3. Recipient's Catalog No.	
4. Title and Subtitle 6 INVESTIGATION OF RECREATIONAL BOAT STEERING AND CONTROL SYSTEMS		5. Report Date 11 APR 1976	6. Performing Organization Code 15 141pa
7. Author(s) 10 John R. Taylor	8. Performing Organization Report No. 14 CGR DC-8/76		9. Contract or Grant No. 765300E.02
9. Performing Organization Name and Address U. S. Coast Guard Research and Development Center Avery Point Groton, Connecticut 06340		10. Work Unit No. (TRAIS) 5260.3	11. Type of Report and Period Covered 9 Final Report
12. Sponsoring Agency Name and Address Department of Transportation U. S. Coast Guard Office of Research and Development Washington, DC 20590		14. Sponsoring Agency Code	
15. Supplementary Notes			
16. Abstract This report represents an in-depth study of the hazards and problems associated with outboard recreational boat steering and control systems. Emphasis is placed on the steering systems. Problem identification work is documented with a review of Coast Guard accident statistics and defect notification files. In addition, manufacturer warranty and liability files are summarized along with a field survey of suspect steering systems, accident investigations, and interviews with marine mechanics. Operational tests have been performed with instrumented test boats to document the level of loadings placed on a steering system both during normal operation and extreme maneuvering situations. Results of laboratory tests on steering systems and their accessories are discussed. Finally, the effectiveness and reliability of steering systems are assessed and compared to the industry-developed standard for outboard steering systems.			
17. Key Words recreational boat, steering system		18. Distribution Statement Document is available to the public through the National Technical Information Service, Springfield, VA 22161	
19. Security Classif. (of this report) UNCLASSIFIED	20. Security Classif. (of this page) UNCLASSIFIED	21. No. of Pages 141	22. Price 408 730

METRIC CONVERSION FACTORS

Approximate Conversions to Metric Measures

Symbol	When You Know	Multiply by	To Find	Symbol
LENGTH				
in	inches	2.5	centimeters	cm
ft	feet	30	meters	m
yd	yards	0.9	kilometers	km
mi	miles	1.6		
AREA				
sq in	square inches	6.5	square centimeters	cm ²
sq ft	square feet	0.09	square meters	m ²
sq yd	square yards	0.8	square meters	m ²
sq mi	square miles	2.6	square kilometers	km ²
acres	acres	0.4	hectares	ha
MASS (weight)				
oz	ounces	28	grams	g
lb	pounds	0.45	kilograms	kg
	short tons (2000 lb)	0.9	tonnes	t
VOLUME				
tblsp	tablespoons	5	milliliters	ml
fl oz	fluid ounces	15	milliliters	ml
c	cup	30	milliliters	ml
pt	pint	0.24	liters	l
qt	quart	0.47	liters	l
gal	gallon	0.96	liters	l
cu ft	cubic feet	3.8	liters	l
cu yd	cubic yards	0.03	cubic meters	m ³
		0.76	cubic meters	m ³
TEMPERATURE (exact)				
°F	Fahrenheit temperature	5/9 (after subtracting 32)	Celsius temperature	°C

Symbol	When You Know	Multiply by	To Find	Symbol
LENGTH				
mm	millimeters	0.04	inches	in
cm	centimeters	0.4	inches	in
m	meters	3.3	feet	ft
m	meters	1.1	yards	yd
km	kilometers	0.6	miles	mi
AREA				
cm ²	square centimeters	0.16	square inches	in ²
m ²	square meters	1.2	square yards	yd ²
km ²	square kilometers	0.4	square miles	mi ²
ha	hectares (10,000 m ²)	2.5	acres	acres
MASS (weight)				
g	grams	0.005	ounces	oz
kg	kilograms	2.2	pounds	lb
t	tonnes (1000 kg)	1.1	short tons	
VOLUME				
ml	milliliters	0.03	fluid ounces	fl oz
l	liters	2.1	pints	pt
l	liters	1.06	quarts	qt
l	liters	0.26	gallons	gal
m ³	cubic meters	36	cubic feet	ft ³
m ³	cubic meters	1.3	cubic yards	yd ³
TEMPERATURE (exact)				
°C	Celsius temperature	9/5 (then add 32)	Fahrenheit temperature	°F

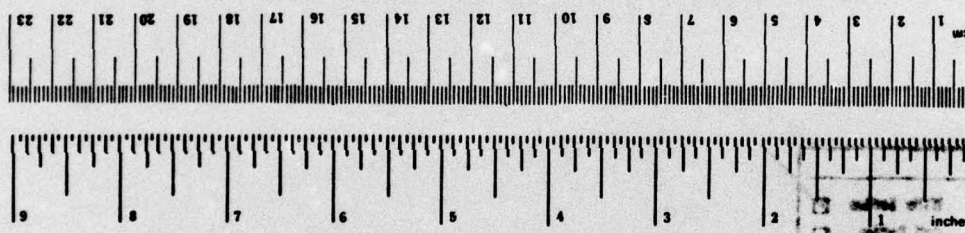

*1 in = 2.54 (exactly). For other exact conversions and more detailed tables, see NBS Misc. Publ. 286, Units of Weights and Measures, Price \$2.25, SO Catalog No. C13.10-286.

TABLE OF CONTENTS

	<u>Page</u>
1.0 INTRODUCTION	1
2.0 OBJECTIVES	1
3.0 CONSTRAINTS/CONDITIONS	1
4.0 R&DC RESEARCH	2
4.1 Method of Approach	2
4.2 Results	2
5.0 INDUSTRY SYSTEM TESTS	5
5.1 Laboratory Cyclic Tests	10
5.2 Other Industry Tests	12
5.3 Comparison to ABYC P-17 Standard	16
6.0 CONCLUSIONS	17
7.0 RECOMMENDATIONS	17
APPENDIX A - STEERING AND CONTROL SYSTEM DEFECT NOTIFICATIONS CAMPAIGN SUMMARY	A-1
APPENDIX B - REQUIREMENTS FOR THE DOCUMENTATION OF RECREATIONAL BOAT STEERING AND CONTROL SYSTEMS	B-1
APPENDIX C - EXCERPTS FROM "FINDINGS FROM A SURVEY OF MARINE MECHANICS REGARDING STEERING SYSTEM FAILURES"	C-1
APPENDIX D - OUTBOARD MOTOR REMOTE STEERING SYSTEMS, ABYC PROJECT P-17	D-1
APPENDIX E - RECREATIONAL BOAT STEERING SYSTEM TESTING, OUTBOARD MARINE CORPORATION	E-1

LIST OF ILLUSTRATIONS

<u>Figure</u>		<u>Page</u>
1	Steering Load Traces from Full Motor Angle Accelerated Turns	6
2	Steering Load Traces Showing Effect of Trim Tab Adjustment	7
3	Motor Angle Drift with No Trim Tab	8
4	Speed, RPM, Steering Load Traces While Striking Submerged Object	9
5	Steering System Efficiency Envelopes	11
6	Output Load vs. Input Torque Envelopes	13
7	System Backlash vs. Input Torque	14

1.0 INTRODUCTION

The initial investigation into the hazards and problems associated with steering and control systems on recreational boats was initiated by the Office of Boating Safety's TSR of 24 May 1973. Due to the complex nature of the systems (i.e., involvement of steering system, boat, engine, and accessory manufacturers) a great deal of industry cooperation ensued. As a result of industry/R&DC staff meetings, R&DC Center participation in the BIA Steering Task Force, and R&DC contracts, a considerable amount of industry instrumented boat tests and laboratory system tests were performed to complement the testing conducted at the R&DC Center. Active industry involvement was obtained from Outboard Marine Corporation, Mercury Marine, Morse Controls, Teleflex, Incorporated, Marmac, American Chain and Cable, Detroit Marine, Glastron, Attwood, and Sheller-Globe Corporation. Analysis of test results has shown that recreational boat steering systems (single outboard mechanical push-pull) are effective, reliable, and efficient in handling the load levels imposed by operational testing if properly installed and maintained. Furthermore, the safety standard developed by the BIA Steering Task Force (proposed ABYC P-17) sets realistic strength requirements from a safety standpoint and more importantly addresses the areas of corrosion, installation, and standardization of parts.

2.0 OBJECTIVES

The objectives of this task may be summarized as follows:

- a. To determine the exact steering and control hazards and their causes.
- b. To determine the actual loading to which a steering system is subjected and the parameters affecting this loading.
- c. To determine the effectiveness of current production steering systems in meeting the loads determined in (b), and the parameters affecting cable fatigue.
- d. To determine the efficiency and reliability of various steering systems in meeting the requirements of (b) and (c).
- e. And finally, to analyze all data and determine the need for Federal standards in these areas.

3.0 CONSTRAINTS/CONDITIONS

It was felt that in order to accomplish this task within the desired time frame, two important considerations were: (1) a limitation of scope, and (2) considerable cooperation between the Coast Guard and industry. As to the former, this initial work was limited to mechanical push-pull steering systems as they are used in conjunction with single engine outboard powered craft. Through the efforts of the R&DC and Commandant (G-BBT) personnel, an excellent rapport was developed with the industry which led to membership on the BIA Task Force on steering

systems. A considerable amount of industry test data and equipment was thereby acquired to complement R&DC tests. Since most of this data was acquired at no cost to the Government, there is the additional constraint that much of the information is proprietary in nature.

4.0 R&DC RESEARCH

This section presents the procedures and results of the R&DC's cause identification work and instrumented boat tests.

4.1 Method of Approach

The identification of the exact steering and control hazards and their causes was separated into various levels of effort. These were:

a. A review of the boating accident report files and the defect notification files associated with steering and control systems.

b. Discussion and review of industry warranty and liability claim files.

c. Investigation of steering and control system associated accidents.

d. A field survey of boat mechanics and marine facilities to collect failed steering systems for a failure mode and effect analysis.

The procedures and maneuvers carried out during the instrumented boat tests were twofold in purpose. First to document the normal operating loads on a recreational boat steering system and, secondly, to document the maximum loads that may result under extreme maneuvering conditions or misadjusted geometry.

4.2 Results

4.2.1 BAR Files and Defect Campaigns

Of the defect campaigns that existed at the time of project initiation and those that occurred since then, very few were related to design oriented problems. Of the 24 campaigns investigated, only seven were remotely connected with design defects that a performance oriented standard would address. The vast majority of these defects resulted from poor dealer/manufacturer communications and quality control procedures. Additionally, over the past four years, according to the BAR files, a total of approximately 250 accidents have been attributed to steering system failures resulting in approximately 36 deaths and over \$60 thousand in property damage. The amount of information, or lack of it, in Coast Guard Headquarters boating accident report files made it extremely difficult to document cases of clear-cut design deficiencies. (Appendix A contains a summary of the defect campaigns underway during this study.)

4.2.2 Warranty and Liability Claim Files

Results of discussions with industry concerning the review of warranty and liability claim files were inconclusive in identi-

ifying the exact hazards that exist. Warranty files, as a general rule, for steering systems are minimal. This is due to the fact that there is an extremely low percentage of return of warranty cards on accessory equipment. (One company estimated their return at 0.1%.) As for liability files, the manufacturers are very cautious as to what information is released and therefore it probably does not reflect the entire picture. Those cases that were mentioned were not of a design oriented nature. It is unfortunate that these cases which are mainly improper installation or part substitution, lack of maintenance, or operator misuse are not verified by court decisions. Each manufacturer, without exception, indicated very few, if any, of the liability cases ever go to trial. For economic and publicity reasons most are settled out of court.

4.2.3 Accident Investigations and Field Survey

During the work, enough information was collected to adequately document five accidents in addition to the nine systems which were collected during the field survey. A brief description of this is given below.

<u>PROBLEM</u>	<u>NUMBER</u>
Circumferential cracking of cable outer cover and subsequent corrosion of wire conduit near output end.	4
Corrosion of ball joint and ball stud severe enough to prevent relative motion of the joint.	3
System frozen at output end from corrosion, salt/dirt buildup. Failure in helm assembly from excessive torque in wheel.	3
Broken steering rod caused by engine striking submerged object and being thrown to full tilt position.	1
Steering rod failure due to stress corrosion cracking through thread root internal to rod end connection.	1
Loss of steering due to cable hub nut vibrating and backing off.	1
Improper tension in cable over pulley system caused cable to jump off helm assembly drum.	1

The above cases compared favorably with the recommendations of marine mechanic interviews. These problems were:

- a. The need for adequate preventive maintenance (periodic lubrication and visual inspection).
- b. The need for better anti-corrosion protection of exposed steering parts.

c. The need for standardization of parts and improved installation instructions to eliminate improper installations and part substitutions.

d. The need for lubrication seals, especially on steering cable rods, support tubes, and engine tilt tubes.

e. The need for improved lubricants to aid in preventing the hardening up and "freezing" of a system due to salt and dirt buildup.

Appendix B presents the requirements for the proper documentation of recreational boat steering and control systems as was developed within the framework of this study. It is intended to serve as a guideline for future hazard/problem identification and accident investigation efforts.

Appendix C presents further information concerning the field survey and marine mechanic interviews.

4.2.4 Instrumented Boat Tests

Instrumented boat tests were conducted by R&DC and three industry manufacturers. The range of loads typical to single engine outboards corresponding to the maneuvers involved are shown below. The loads are all given in pounds force normal to the motor tiller arm and in the plane of motion of the tiller arm.

<u>AVERAGE LOAD (lbs)</u>	<u>MANEUVER</u>
30-50	Normal operation in smooth water; no drastic maneuvers.
80-150 w/peaks up to 180	Quick acceleration DIW to full throttle with full motor angle; changing direction of turn while accelerating; tight turns and figure 8's in 6" to 1' chop.
200-300	Tight turns at approximately 20 MPH in 2' seas; striking submerged object throwing motor out of water.
200-250	Impact loads from propeller re-entry with 0° motor angle.
400-430	Impact loads from propeller re-entry with starboard motor angle and port yaw on boat or vice versa.

Steering wheel torques for the above maneuvers varied between 3 and 9 foot pounds. Assuming a 15-inch diameter wheel these loads translate to approximately 5 to 15 pounds wheel effort, which is well within an operator's normal capability. The highest wheel torque in any of the testing was 24 foot pounds (38.4 lb. wheel effort). This was recorded on a reentry with the

boat in a port yaw attitude with starboard motor angle. Additionally, it was found that lower unit trim tab and engine tilt setting have a significant effect on steering loads. Steering arm loads have been found to vary in RMS average as much as 100 pounds due to misalignment of the trim tab. The tilt setting will alter steering loads and wheel torques since this setting controls the amount of underwater hull form of the boat. Each individual boat/motor combination must be "water tested" to insure optimum adjustment.

Figures 1 through 4 show sample plots of the data from some of these typical maneuvers. In Figure 1 the steering load measured normal to the motor tiller arm is shown during accelerated turns. In this maneuver the boat is "dead in the water" with full motor angle and then full throttle is suddenly applied. Due to propeller cavitation this condition can be maintained for only the short durations shown. On a typical recreational boat steering installation, the high tensile loads are placed on the steering rod when it is extended (i.e. starboard motor angle) and the compressive loads occur on the retracted rod. It is important to note that the system design and geometry prevents a more critical condition from occurring (i.e. compressive loads placed upon an extended steering rod).

Figure 2 shows a comparison of the steering loads which exist during a straight course acceleration from zero to full speed with optimum and misadjusted lower unit trim tab setting. In the upper tract the effect of the transition to planing mode is evidenced by the reversal of steering loads as the wetted surface and hull forces change. The lower trace shows that the trim tab setting can account for upwards of a 100-pound increase causing the boat, in this case, to pull violently to starboard.

Figure 3 is included to show the importance of the trim tab to balance the torque produced by the outboard. With no trim tab installed and the boat being operated in a "hands off" condition the motor angle is shown to continuously drift off center. While at steady state speeds this change in motor angle is relatively slow, it could be more drastic under conditions of quick acceleration or rough water conditions.

Figure 4 shows traces of boat speed, engine rpm, and steering load which were recorded when the lower unit of the outboard struck a submerged object causing the propeller to be thrown out of the water. As may be seen from the time reference, at the point of contact, the rise in steering load is accompanied by a reduction in boat speed and a significant increase in engine rpm. The twin peak in the rpm trace is in all likelihood a false reading resulting from an interference signal caused by the closing of the engine kill switch circuit.

5.0 INDUSTRY SYSTEM TESTS

In order to document the efficiency, effectiveness, and reliability of current production steering systems various industry tests were conducted under requests from the R&DC and/or the BIA Steering Task Force.

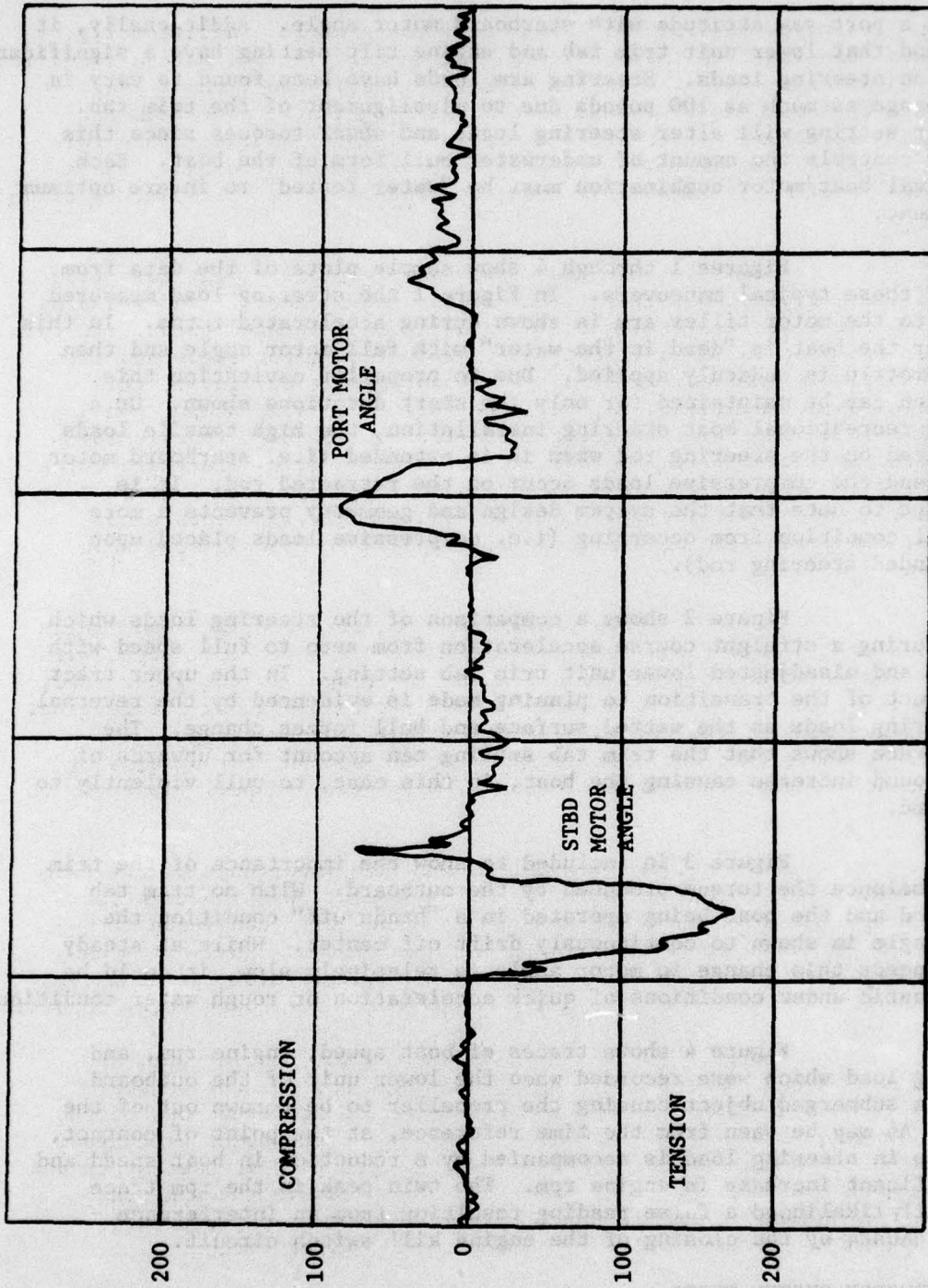

TIME (4 sec/div)

Figure 1. Steering Load Traces from Full Motor Angle Accelerated Turns

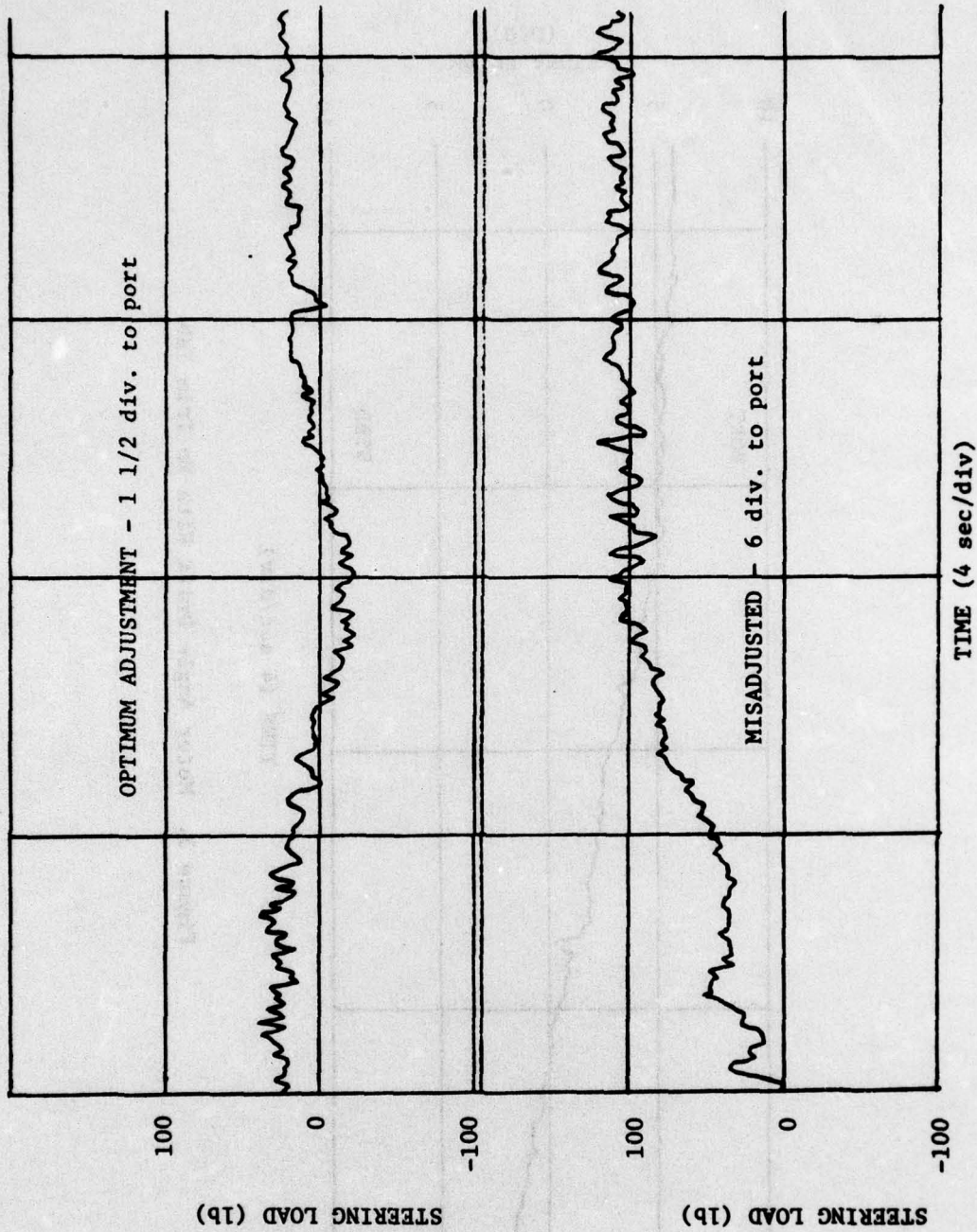

Figure 2. Steering Load Traces Showing Effect of Trim Tab Adjustment

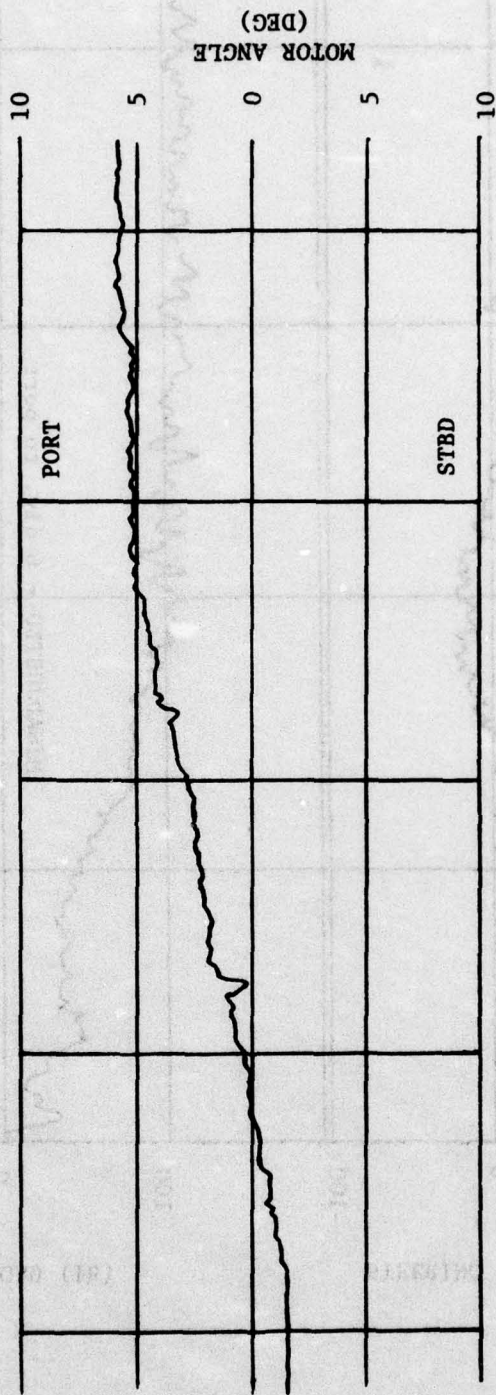

Figure 3. Motor Angle Drift With No Trim Tab

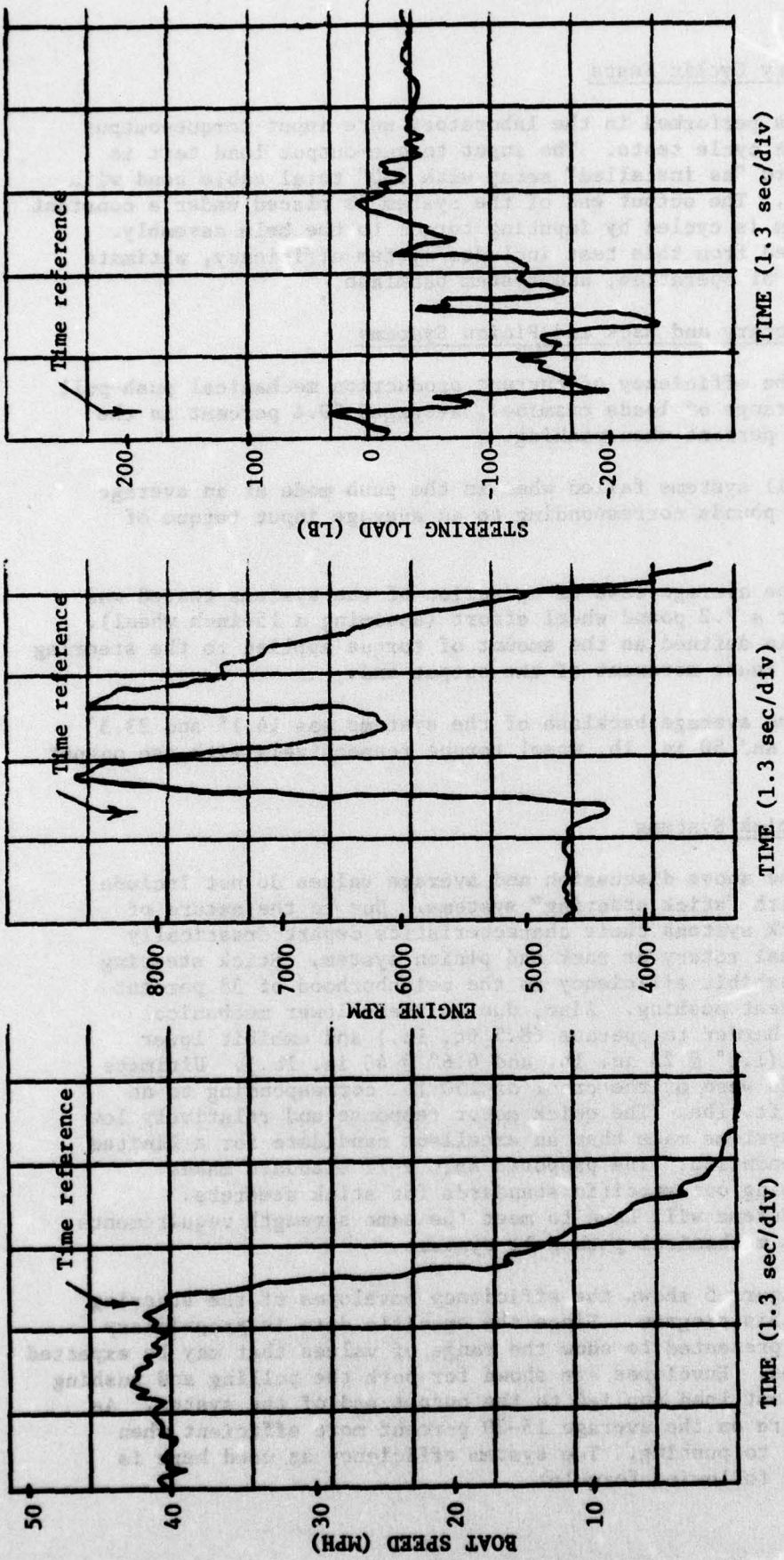

Figure 4. Speed, RPM, Steering Load Traces While Striking Submerged Object

5.1 Laboratory Cyclic Tests

The tests performed in the laboratory were input torque-output load tests and life cycle tests. The input torque-output load test is run under a standard "as installed" setup with 270° total cable bend with 10-inch bend radii. The output end of the system is placed under a constant load and the system is cycled by inputting torque to the helm assembly. Information received from this test includes system efficiency, ultimate failure load, ease of operation, and system backlash.

5.1.1 Rotary and Rack and Pinion Systems

The efficiency of current production mechanical push-pull systems, over the range of loads examined, averaged 50.4 percent in the pull mode and 41.4 percent when pushing.

All systems failed when in the push mode at an average output load of 590 pounds corresponding to an average input torque of 59.8 foot pounds.

The average ease of operation of the systems tested was 1.38 foot pounds or a 2.2 pound wheel effort (assuming a 15-inch wheel). Ease of operation is defined as the amount of torque applied to the steering wheel necessary to cause movement of the output end.

The average backlash of the systems was 14.1° and 23.5° under a 25 in. lb. and 50 in. lb. wheel torque respectively with the output end locked.

5.1.2 Stick Systems

The above discussion and average values do not include those associated with "stick steering" systems. Due to the nature of application of stick systems their characteristics depart drastically from the conventional rotary or rack and pinion system. Stick steering systems generally exhibit efficiency in the neighborhood of 38 percent pulling and 29 percent pushing. Also, due to their lower mechanical advantage they are harder to operate (8.5 ft. lb.) and exhibit lower backlash figures. (1.1° @ 25 in. lb. and 6.6° @ 40 in. lb.). Ultimate failure output loads were of the order of 150 lb. corresponding to an input torque of 26 ft. lbs. The quick motor response and relatively low strength of these systems make them an excellent candidate for a limited application recommendation. The proposed ABYC P-17 standard makes no attempt at singling out specific standards for stick steerers. Therefore, these systems will have to meet the same strength requirements as the conventional mechanical push-pull systems.

Figure 5 shows the efficiency envelopes of the steering systems tested in this program. Since the specific data is proprietary to industry, it is presented to show the range of values that may be expected with current systems. Envelopes are shown for both the pulling and pushing mode versus a constant load applied to the output end of the system. As expected, systems are on the average 15-20 percent more efficient when pulling as compared to pushing. The system efficiency as used here is determined from the following formula:

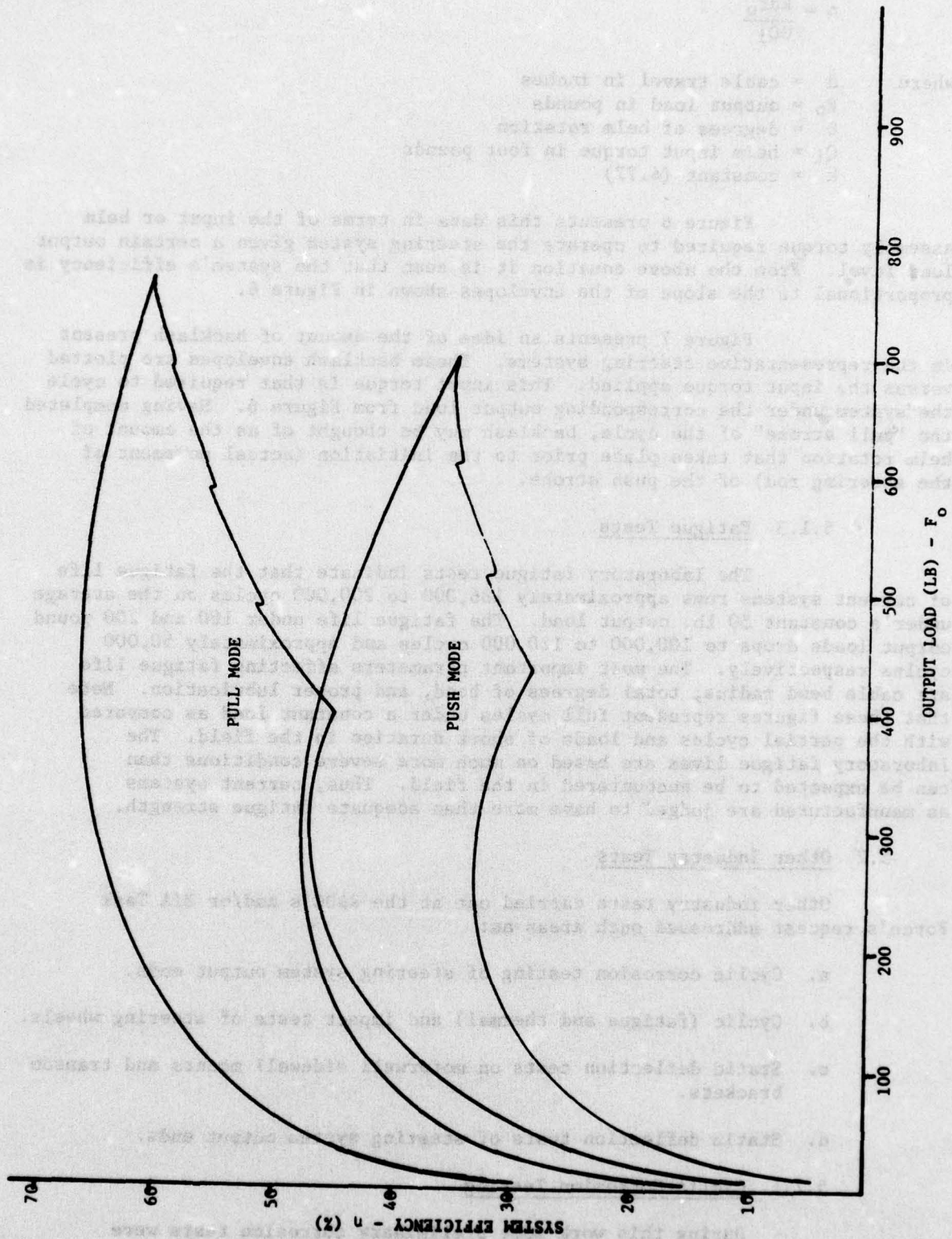

Figure 5. Steering System Efficiency Envelopes

$$\eta = \frac{kdF_0}{\theta Q_1}$$

where

- d = cable travel in inches
- F₀ = output load in pounds
- θ = degrees of helm rotation
- Q₁ = helm input torque in foot pounds
- k = constant (4.77)

Figure 6 presents this data in terms of the input or helm assembly torque required to operate the steering system given a certain output load level. From the above equation it is seen that the system's efficiency is proportional to the slope of the envelopes shown in Figure 6.

Figure 7 presents an idea of the amount of backlash present in the representative steering systems. These backlash envelopes are plotted versus the input torque applied. This input torque is that required to cycle the system under the corresponding output load from Figure 6. Having completed the "pull stroke" of the cycle, backlash may be thought of as the amount of helm rotation that takes place prior to the initiation (actual movement of the steering rod) of the push stroke.

5.1.3 Fatigue Tests

The laboratory fatigue tests indicate that the fatigue life of current systems runs approximately 186,000 to 200,000 cycles on the average under a constant 50 lb. output load. The fatigue life under 100 and 200 pound output loads drops to 100,000 to 120,000 cycles and approximately 50,000 cycles respectively. The most important parameters affecting fatigue life are cable bend radius, total degrees of bend, and proper lubrication. Note that these figures represent full cycles under a constant load as compared with the partial cycles and loads of short duration in the field. The laboratory fatigue lives are based on much more severe conditions than can be expected to be encountered in the field. Thus, current systems as manufactured are judged to have more than adequate fatigue strength.

5.2 Other Industry Tests

Other industry tests carried out at the R&DC's and/or BIA Task Force's request addressed such areas as:

- a. Cyclic corrosion testing of steering system output ends.
- b. Cyclic (fatigue and thermal) and impact tests of steering wheels.
- c. Static deflection tests on motorwell sidewall mounts and transom brackets.
- d. Static deflection tests of steering system output ends.

5.2.1 Cyclic Corrosion Testing

During this work some preliminary corrosion tests were conducted by the industry in order to aid the BIA Task Force in developing

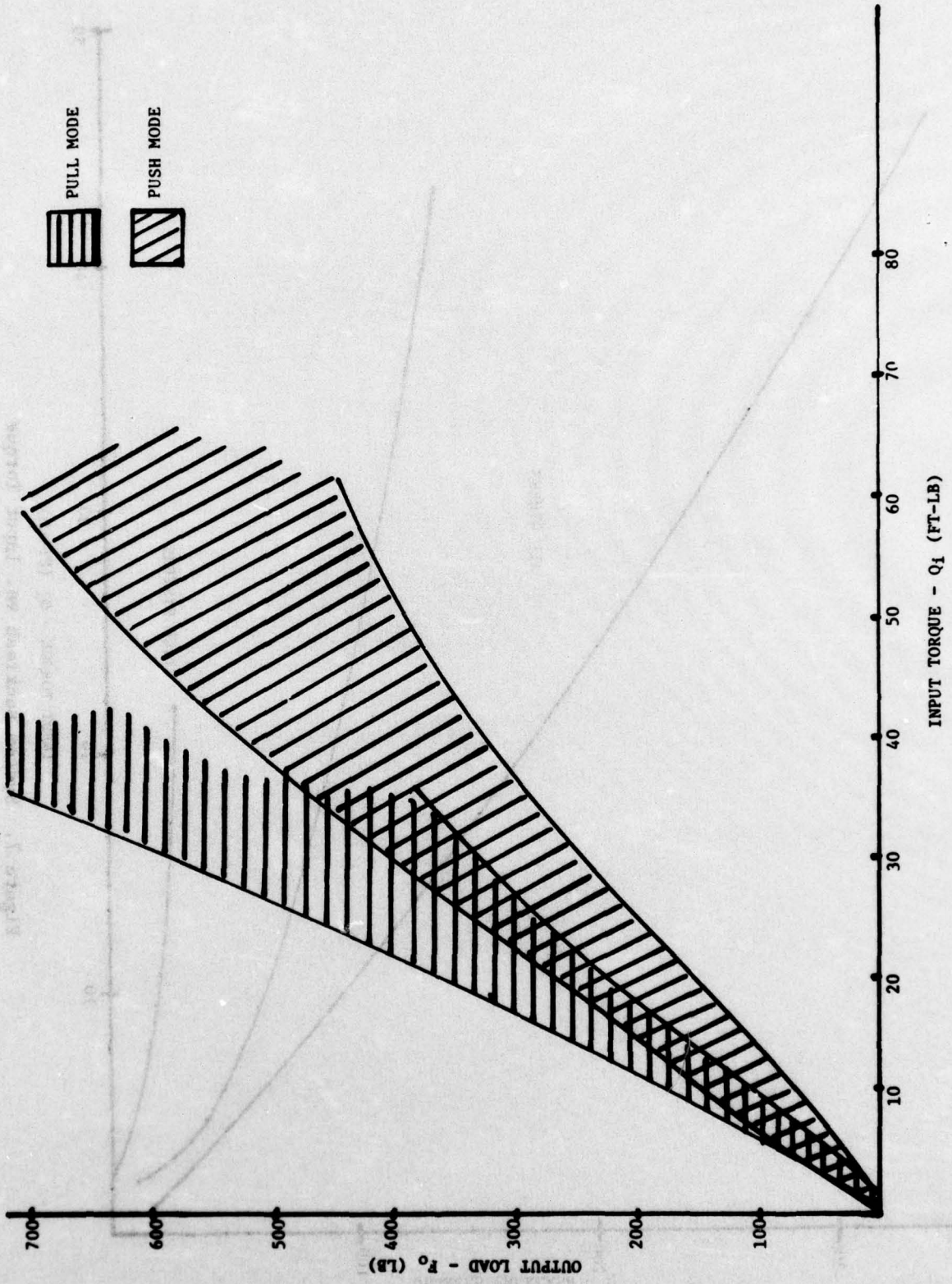

Figure 6. Output Load vs. Input Torque Envelopes



Figure 7. System Backlash vs. Input Torque

a corrosion test program for outboard steering systems. Although specific results are not given here, the industry has demonstrated its capability to produce a steering system able to withstand this test and retain its original function. That is, efficiency, backlash, and amount of travel do not depart from their original design values. Basically, the corrosion test procedure involves pre-test ultraviolet exposure of the output end (including cable sheathing and seals) of the steering system. Followed by a cyclic salt spray test. The latter is conducted in accordance with ASTM B 117-73 (ANSI Z118.1) Standard Method of Salt Spray (Fog) Testing.

Notwithstanding the above discussion, there still remains some concern among industry with respect to the proposed test. It is felt that the evaluation of test results listed in Section P-17.8C.(2) of Appendix D leaves too much interpretation to the evaluator. Thus, the industry feels that problems could arise. As an example, a strict interpretation could fail a system utilizing a stainless steel output ram due to no more than "cosmetic" corrosion while a liberal interpretation could allow a weaker system; i.e. cadmium-plated carbon steel ram, to pass the test.

The current ABYC P-17 standard is scheduled to become effective in August of 1977. As a result, there is a strong possibility that prior to this standard taking effect, the corrosion test itself, along with the evaluation of test results, will be revised. Current plans call for the revision to be more strict. This will be accomplished, in all likelihood, by increasing the number of exposure hours in the salt spray chamber. By utilizing a stricter requirement the interpretive element is removed from the test result evaluation.

5.2.2 Steering Wheel Tests

Some testing has been performed on "insertless" plastic steering wheels. Although the data is again proprietary, the following summary is provided. Current insertless wheels seem to have no problem in passing combined torsion and bending cyclic tests adapted from the automotive industry. All wheels withstood in excess of 50,000 cycles of fatigue testing without failure. The same may be said for static deflection tests conducted under a load of 150 pounds at sub-zero temperatures. Under the 200 foot-pound impact test (Appendix D) all wheels suffered some damage. The extent of this damage varied from only minor blishes to complete shattering of the spoke and rim. The wheels underwent two additional tests. First, 15 complete alternating cycles of 150 to 160 pound axial loading and second, three thermal cycles of -40°F to 180°F . After both of these tests the wheels were tested to destruction statically. In all cases, the wheels failed at load levels higher than the previously mentioned 150 pound static deflection test.

5.2.3 Static Deflection Tests on Motorwell Sidewall Mounts and Transom Brackets

At the request of the BIA Task Force a series of tests were conducted to investigate the strength of steering system anchorages attached to boats. Basically there are two types of boat mounted steering systems. The steering cable is anchored to the boat either by passing it

through a transom bracket mounted to the transom or a gimbal mount connected directly to the motorwell sidewall. These are shown in Figure 3 of Appendix D. The proposed industry standard, developed by the BIA Task force requires an "as installed" test which places 750 pounds along the axis of the output steering ram. Since this is an "as installed" test the mounting devices must also withstand these loads. Both the sidewall and transom-mounted systems were tested and included products from a wide range of manufacturers. In summary, all anchorages were found to be adequate for sustaining the 750-pound load without failure or structural damage. In general, the motorwell sidewall mounts will withstand higher load levels and display smaller deflections. With transom-mounted systems, it was discovered that a good amount of deflection can result from crushing of the transom plywood rather than bending of the bracket itself.

5.2.4 Static Deflection Tests of Steering System Output Ends

These tests were conducted as part of the work conducted by Outboard Marine Corporation under contract to the R&D Center. Since this report is shown in its entirety in Appendix E, only a brief summary is discussed here. The static tests were structured so as to define the steering system geometry that would place a maximum load on the member of the system that will fail initially under increasing loads. Critical deflections were measured under various loads to determine the level of loading that causes the onset of permanent deflection and that which causes failure of the system to function throughout its normal range. Whenever possible, the systems were misadjusted to ascertain the worst possible condition.

It should be noted that Appendix E also contains dynamic tests conducted with instrumented boats. These tests were designed to measure the steering loads under the most severe conditions such as wave jumping with high speed prop reentry and high speed turns including total spinouts. In anticipation of future work these tests were conducted with twin outboard, single I/O, and twin I/O powered craft.

5.3 Comparison to ABYC P-17 Standard

Whereas the systems tested proved effective in meeting the strength requirements established by operational tests there are several areas which will need improvement in order for them to meet all requirements of the proposed ABYC P-17 standard. These are:

- a. Corrosion of ball joints, drag links and support brackets.
- b. Fractures of "insertless" steering wheels under impact and thermal cycling.
- c. Deflection of drag links under static deflection tests.
- d. Excessive deflection in transom-mounted bracket systems.

The P-17 Standard is shown in Appendix D.

6.0 CONCLUSIONS

The primary conclusions of this work are:

- a. The loads experienced by a recreational boat steering system for single engine outboards equipped with mechanical push-pull systems are not considered excessive.
- b. Current systems are of adequate efficiency, effectiveness and reliability to meet these loads if properly installed and maintained.
- c. The industry has demonstrated its capability to self regulate. The proposed ABYC P-17 standard developed by the BIA Steering Task Force addresses the correct problems and sets realistic strength requirements from a safety standpoint.
- d. The predominant problems with recreational boat steering systems result from lack of preventive maintenance, improper lubrication, improper installations because of non-standardized parts and/or sufficient installation instructions, and environmental degradation from salt water and ultraviolet exposure.
- e. The number of lives lost and level of property damage documented in Coast Guard BAR files is insufficient to justify a need for a Federal standard for outboard steering systems.

7.0 RECOMMENDATIONS

Therefore, the following recommendations are made:

- a. That there is no necessity to develop a Federal safety standard for mechanical push-pull steering systems now used with single outboard engine recreational boats at this time.
- b. That the Coast Guard strongly encourage the industry's compliance to the proposed ABYC P-17 standard in that ABYC P-17 standardizes parts, provides for corrosion protection, and establishes strength requirements which are realistic.
- c. That the Coast Guard, through the use of the Boating Safety Circular and educational efforts stress the importance of such areas as:
 - (1) Proper lubrication and preventive maintenance (especially at the beginning of the boating season).
 - (2) The need for improved, clearly defined installation instructions.
 - (3) The use of self-locking threaded fasteners in critical points of the steering system.
 - (4) The importance of proper lower unit trim tab and engine tilt adjustment.

d. That the Coast Guard be aware that, upon publishing of the ABYC P-17 standard, there is a three-year compliance period. Care will have to be taken so as not to compound the non-standardization problems as engine, steering system, and accessory manufacturers make their changeovers. The Coast Guard must also be aware that this is a voluntary program on the part of the industry. The proposed ABYC P-17 standard is slated to take effect in August of 1977. This same P-17 standard has been adopted by the BIA as part of its 1977 BIA Certification Handbook which takes effect August 1976. (NOTE: Due to the likelihood that the corrosion test section of the P-17 standard will be revised, this portion will be "advisory only" for BIA certification until August of 1977.)

e. That the Coast Guard remain active in its participation with the BIA Task Force as it progresses to twin outboard, I/O, and cable-over-pulley systems.

REFERENCES

Boating Industry Association (BIA) Steering Task Force Meetings,
various minutes and memoranda.

Boating Statistics (CG-357), U. S. Coast Guard, 1970, 1971, 1972, 1973.

Miller, James M., Human Factors Application in Boating Safety,
The University of Michigan, Ann Arbor, MI, September 1973.

Plantec, Peter, Findings From a Survey of Marine Mechanics Regarding
Steering System Failures, Operations Research, Inc., Silver Spring, MD,
October 1974.

Steering Malfunctions, 1972, A Study of Boat Accident Report Data
for the Boating Standards Division, Office of Boating Safety,
U. S. Coast Guard.

APPENDIX A

STEERING AND CONTROL SYSTEM DEFECT NOTIFICATION CAMPAIGN SUMMARY STEERING SYSTEM DEFECTS*

DESIGN RELATED

- a. Mechanical push-pull steering with inboard-outboard engine. Apparently the ball joint used to connect steering rod to outdrive fails after a few weeks in service. There was some uncertainty as to the actual problem and cause; however, salt water corrosion was a strong possibility.
- b. An aluminum steering bracket manufactured for I/O installation was felt to be questionable in its ability to hold up under turning loads. At the time of investigation the bracket was being replaced with cadmium steel.
- c. Hydraulic push-pull steering system for use on I/O installation. Steering arm between the hydraulic cylinder and outdrive tiller arm unscrews. Easily remedied by means of a pin.
- d. Steering yoke failures on twin V-8 I/O installations. This failure occurred on twin installations only and at high speeds (45+ mph). Was attributed to the high impact loadings placed on the steering system when the propellers reenter the water after having been airborne. New parts were made utilizing stainless steel to provide more strength. Also addressed was a speed governor to limit propeller rpm.
- e. Continuation of (d) above. This time the steering arm was suspected and, although there were no failures, it was replaced by a stronger unit.

OTHER THAN DESIGN RELATED

- f. Mechanical push-pull system for 65HP outboard. In this installation the dealer must cut the transom well hole and place the transom bracket in the proper location. As the hole location varies with the boat no template is provided as an installation guide. The installer misplaced the bracket thereby causing a bending load to be placed on the stainless shank at the outer cable hub when the engine is tilted.
- g. The steering lever on certain I/O installations became loose after a period of service. Cause attributed to lack of quality control in that steering lever fasteners were not properly torqued.
- h. Mechanical push-pull steering on certain I/O installations. The steering system manufacturer provides a jam nut with the ball joint connection kit. The I/O manufacturer supplies a special extension adaptor to be used in lieu of the jam nut. In order to provide adequate strength in the connection the extension adaptor must be threaded until bottomed. Due to a mix-up in instruction bulletins, the jam nuts were not being removed prior to installation of extension adaptor. This left the adaptor only partially threaded causing a high probability of failure at the fitting.

*Specific manufacturer names (i.e., steering system, boat, and engine) have been omitted.

i. Mechanical push-pull stick steering system. The steering this installation is held in place by means of a clamping bolt. The bolt could not be overtorqued due to a designed thread failure. The supplier changed to a higher grade bolt without steering manufacturers' knowledge. Results were that bolt could now be overtorqued causing hub failure and subsequent loss of steering.

j. Transom bracket mount for mechanical push-pull system. The boat manufacturer in this case fastened the mounting bracket to the transom with lag screws. The screws were too short and would pull out of the transom. The manufacturer subsequently replaced with longer lag screws. (Note: It would appear that thru-bolting would have been a much better solution.)

k. Steering arm-engine connection. In this case the boat manufacturer installed the clevis bolt upside down. This is the bolt that connects the steering output arm to the motor tiller arm. Vibration would cause the nut to loosen, back off and fall in the bilge causing a potentially hazardous situation.

7 Mechanical push-pull steering. Steering cable

e. Outboard motor throttle control. This is a single case and was somewhat unclear as the investigation was still on-going. The problem was that the motor would stick at wide open throttle. There was evidence, however, of owner abuse in that the engine would be placed in gear at a high rpm causing jamming problems with the clutch dogs.

f. Throttle cable. This was a clear case of improper installation. The throttle cable was installed with a 45° bend (included angle) at the control head and another 45° bend at the motor connection. This led to excessive force required to effect throttle changes.

g. Jet drive. In this case the reverse gate pivot pin bolts were insufficiently torqued causing improper operation of the gate.

h. Outboard motor shift rod assembly. The motor manufacturer was obtaining shift rod hydraulic plungers from five different vendors. One vendor was supplying these plungers with improper machine grooves resulting in shift problems.

i. Motor control head. This again was a single case occurrence. It involved a report of excessive binding in the control head making throttle and shift operation difficult. Result was that the binding was due to excessively tight adjustment on the control head friction adjustment. Simply backing off on the friction adjustment solved the problem.

What was the identified problem? What components involved?

What caused the problem:

- Improper design
- Insufficient strength
- Improper installation
- Excessive loads
- Misuse
- Excessive use (normal wear)
- Corrosion
- Improper maintenance

How remedied?

Type 3 -

What component(s) appear suspect? Why?

- Corrosion of functional surfaces
- Bent or deformed components
- Improper/altered installation
- Mismatched systems
- Age of system
- Other (specify)

Comments:

Section 2.2 is aimed primarily at the marine/dealer mechanic who has knowledge of the day-to-day problems associated with steering and control systems.

1.2 Practices and Procedures. Questions to be answered include:

- 1) Are installation instructions always available? If so, are they clear and specific?
- 2) Are installation instructions followed? To what degree?
- 3) How are motorwell wall cutouts and access holes located?
- 4) How are transom brackets located?
- 5) What percentage of time spent on installation of systems?
- 6) Is the system performance tested upon installation? (I.e., motor arc, engine trim tab, engine tilt, position, etc.)
- 7) What amount of systems are returned to manufacturer? Why--warranty, overstock, etc.
- 8) What are the most frequent failures and complaints concerning steering and control systems and what are their causes?

Failure/problem

Cause

1., etc.

- 9) Is the responder willing to keep a running total of his answer to question 8 over a period of time?
- 10) Is there a definite correlation between steering and control problems and specific manufacturers? If so, what?

2.0 SURVEY DOCUMENTATION

This section covers in detail the documentation required for a complete analysis of the boat/engine/steering and control systems. While it is anticipated that every sampled system under investigation will not allow completion of all the following, every effort should be made to complete as much as possible from the various sources available. The information is broken down in four categories. These are:

- 2.1 Boat
- 2.2 Engine
- 2.3 Steering System
- 2.4 Control System

2.1 Boat

Mfg _____ Model _____ Yr Mfg _____ HIN _____
Length _____ Beam _____ Weight _____
Type: _____ Outboard _____ I/O _____ Jet _____
Hull form: _____ Deep Vee _____ Semi-Vee _____ Tri-Hull _____
_____ Flat Bottom _____ Round Bottom _____ Tunnel _____
_____ Pontoon _____ Other _____
Hull material: _____ Fiberglass _____ Aluminum _____ Wood _____ Other _____
Transom cutout: _____ Yes _____ No _____
Motorwell: _____ Yes _____ No _____
Certification: _____ BIA _____ Mfg compliance label _____
Max HP _____ Max Wt Cap _____ Max persons cap _____
Transom height _____ Transom thickness _____
Motorwell width _____ Transom angle _____°

Dimensional sketch of stern including transom cutout and motorwell, also showing size and location of motorwell access holes.

- Photos: 1) Bow
2) Stern
3) Profile
4) Overhead, looking forward
5) Overhead, looking aft
6) Others as deemed necessary

2.2 Engine

Mfg _____ Model _____ Serial # _____
Yr mfg _____ Mfg HP _____ Weight _____ lb

2.2.1 Outboards

Power trim/tilt: _____ Yes _____ No
of tilt pin positions _____ Position being used _____
Single engine centered on transom _____ Yes _____ No
Twin engine centerline spacing _____
Max motor angle _____° Stbd _____° Port _____
Engine attachment _____ Tiller arm _____ Tilt pin _____
If tiller arm has two holes, which is being used for steering: _____ forward _____ aft
Tiller arm radius _____ in.
Dimensional location of tilt pin or tiller arm with reference to top fwd corner of transom and boat centerline.

2.2.2 Inboard/Outboard or Jet

Drive Mfg _____ Model _____ Serial # _____
Power trim/tilt: Yes _____ No _____
Drive attachment: _____ Tiller arm _____ Thru transom _____
Worm gear _____
Max drive angle: _____° Stbd _____° Port _____
Photo documentation as necessary.

2.3 Steering System

The recreational boat mechanical steering system can be broken into four categories:

- 1) Steering wheel
- 2) Helm assembly
- 3) Cable assembly and integral fittings
- 4) Engine connection kit

2.3.1 Steering Wheel

Mfg _____ Model _____
Diameter _____ Inserted: Yes _____ No _____
Hub attachment: _____ Round taper _____ Square taper _____
Spline _____
Total rotation stop to stop _____°
Inspect for cracks; deformation; interference with boat, driver, controls; excessive steering effort; and proper installation.

2.3.2 Helm Assembly

Mfg _____ Model _____
Type: _____ Rotary _____ Rack and pinion _____
Single _____ Dual _____
Inspect for corrosion, excessive backlash, excessive endplay, tightness of cable attachment nut, proper installation.

2.3.3 Cable Assembly and Integral Fittings

Mfg _____ Type _____ Cable length _____ ft
Total degrees of bend _____°
Cable radii _____ in. at helm _____ in. at transom _____ in. at (other, specify) _____
Max cable travel _____ in.
Diagram of routing showing measurements for cable length.

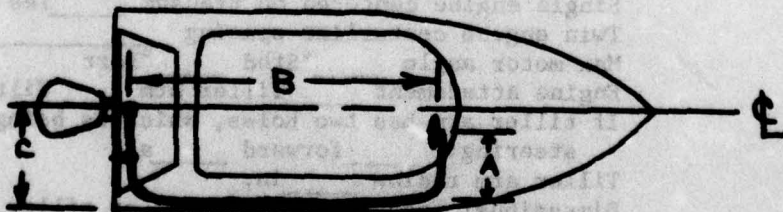

Inspect cable for corrosion of end fittings and steering rod; evidence of moisture or lack of lubrication; permanent deflection of steering rod; cuts, gouges, or other damage to cable; proper installation.

2.3.4 Engine Connection Kit

Mfg _____

Type: _____ Engine mounted (thru tilt pin)
_____ Boat mounted _____ Transom bracket
_____ Splash well mount

2.3.4.1 For boat mounted:

Location of transom bracket or splash well mount pivot point:

- a) Distance from engine centerline to pivot _____ in.
- b) Distance of pivot fwd of transom _____ in.
- c) Height of pivot above or below transom _____ in.

Total degree of articulation in pivot _____
Inspect cable hub nut attachment to transom support tube for tightness and corrosion.

Inspect transom support tube for interference-free pivoting.

Inspect seals for cracks, aging effects, etc.

Type of engine attachment:

- _____ Quick release ball joint and ball stud
- _____ Ball joint with threaded fastener
- _____ Integral ball joint/stud
- _____ Clevis

If dual installation, is there a tie bar? _____ Yes _____ No

2.3.4.2 For engine mounted (thru tilt pin):

Inspect cable hub nut attachment to engine for tightness and evidence of corrosion.

Total steering rod extension _____ in.

Type of drag link steering rod connection:

- _____ Thru steering rod hole
- _____ Thru threaded connector

Type of engine attachment:

- _____ Quick release ball joint and ball stud
- _____ Ball joint with threaded fastener
- _____ Integral ball joint/stud
- _____ Clevis

If dual installation, is there a tie bar? _____ Yes _____ No

2.3.4.3 For both types of mount:

Inspect system for interference throughout the entire steering arc in both the run and tilt positions. Inspect connection kit for compliance with installation procedures.

3.0 CONTROL SYTEM (THROTTLE AND SHIFT)

Mfg _____ Model _____

Cable length _____ ft

Start-in-gear protection: _____ Yes _____ No

Single lever _____ Double lever _____

Inspect for excessive force to effect movement, evidence of binding, integrity of cable fittings and attachments, and corrosion.

Inspect for interference with steering wheel, boat, or driver.

Diagram of cable routing and cable bend radii.

Does it comply with recommended installation practices? _____ Yes _____ No

APPENDIX C

EXCERPTS FROM "FINDINGS FROM A SURVEY OF MARINE MECHANICS REGARDING STEERING SYSTEM FAILURES"

It must be borne in mind that much of the information in this appendix comes from direct interviews with marine mechanics. The views and opinions included are those of the mechanics only. References to specific manufacturers of brand names have been deleted.

PURPOSE

This survey is a study of the nature and types of steering failures in two categories of power boats:

1. Outboard motor boats
2. Inboard/outboard motor boats

More specifically, the survey attempts to indicate if the relationship between steering failures and boating accidents is significant enough to warrant further research.

PROCEDURES

There are two parts to the survey: (1) interviews with 34 boat mechanics and (2) the collection of 50 defective steering systems. The scope of the survey is limited primarily to marinas, dealers, and service centers in the Baltimore-Washington-Annapolis area with several interviews in Miami, Florida, presented separately. Interviews were conducted during the second week in May, the last week in July and the first week in August, 1974.

Several interview techniques were used which required probing for depth of answers. Probes were used with the utmost care to avoid leading the respondent. In some cases unobtrusive measures were used, such as stimulating a conversation about steering mechanisms between two mechanics and then recording the relevant output. In general the interviews were low profile, informal affairs, designed to fit into the mechanic's routine as much as possible. Coast Guard involvement was not emphasized, nor was it hidden.

I. CLASSIFICATION OF STEERING SYSTEMS

Defective systems have been classified into one of the following types:

Type I: System failure has already occurred leaving the system inoperative unless repaired or replaced.

Type II: System which has some type of damage or wear leading to a reduction in original capability, but which still operates in a limited capacity (e.g., customer complaints of "squeaks" or "hard steering").

Type III: System which has not failed nor prompted owner to seek correction but nevertheless appears suspect for various reasons (e.g., corrosion of functional surfaces, bent or deformed components, improper or altered installation, mismatched systems, excessive age or use).

Each defective system was to be further documented by interviews with the owners of the boats and with the mechanics who replaced or repaired the system. These interviews focus on the circumstances of the failure or partial failure of the system.

In addition to the interviews concerned with specific instances of failure, more general interviews with mechanics were also undertaken. Specific questions were asked during interviews but the responses and format were open-ended. These interviews had the flavor of informal discussions with mechanics, designed to elicit information about steering systems. For example, in some instances responses were recorded after the interview was completed, in order to keep the anxiety level of the mechanics at a minimum.

II. COMPILATION OF RESPONSES FROM MECHANIC INTERVIEWS AND SAMPLE ANSWERS

A profile of the 34 mechanics interviewed can be made from the responses given to Questions 3-5 on the Mechanic Interview Questionnaire. The responses given to Questions 6-10 were all nearly the same and therefore a breakdown of answers is not given. Instead, representative responses from the questionnaire are quoted. Questions 1 and 2, Name and Place of Employment, are not included.

Question 3 - Years of Experience

Years of experience ranged from 2 years to 30 years. A breakdown of mechanic experience follows:

<u>Years of Experience</u>	<u>No. of Mechanics</u>
1-5	16
6-10	4
11-15	3
16-20	7
21-30	4
Total	34

Question 4 - What percentage of small boat repairs that you do is concerned with steering mechanisms?

The most frequently given answer to this question was less than one percent. One answer given, "Ten percent in April and May," is rather hard to interpret since the respondent did not answer the question in its entirety. For the tally purpose, this answer will not be counted.

<u>Percentage of Steering Repairs</u>	<u>No. of Mechanics</u>
Less than 1%	29
Less than 5%	1
5%	1
No answer	2
Total	33

Question 5 - How many steering mechanisms do you repair in the course of a year?

The answers to this question ranged from "none in past year" to "50." The breakdown is shown below.

<u>No. of Repairs</u>	<u>No. of Mechanics</u>
1-5	20
6-10	6
11-15	1
16-20	1
21-30	3
40-50	2
None in past year	1
	Total 34

Question 6 - Do you know of any steering failures that caused accidents or near accidents? If yes, what are the details.

Only three mechanics answered yes to this question. All other 31 respondents answered no. Of those three who answered yes, no in-depth details were given. The answers are listed below.

"Tiller system failed - boat capsized - no one hurt."

"Loss of steering but no accident. Boat sustained minor damage. The quick couple on the post broke."

"Tiller arm pin sheared off leading to an accident."

Question 7 - Are there any systems which seem to have significantly more problems than others?

"Tiller type cable systems which use pulleys are the least satisfactory - pulley comes loose - cables twist - cables seem to rust up quicker."

"All systems OK when properly maintained. Mechanical systems better than tiller on boats over 40 h.p."

"Mechanical systems are the best. Old tiller type more prone to rust, twisted cable or broken cable. No good on boats over 40 h.p. anyway."

"Cable systems have more problems than telescopic systems."

Question 8 - Describe specific types of steering mechanism failures that you are familiar with.

"Most failures result from corrosion of components and rust, twisted cables, cables that are too long. Trim tab adjustments also account for failures."

"The most frequent type of failure occurs at the beginning of the boating season. The stern end of the cable freezes up due to rust and corrosion. All other types of failures are extremely rare."

"Tiller type systems - cables rust or snap. They can snap if they are twisted and this could lead to an accident. Mechanical steering freezes up from rust caused by lack of lubrication."

Question 9 - What improvements could be made in steering mechanisms to reduce the probability of failure?

"Reroute cable so it stays away from manifold."

"More grease fittings on cable, the use of non-corrosive material for cables. All steering arms should be brass or stainless steel, tighter seals to prevent water from getting inside cables."

"The use of brass or stainless steel components where corrosion is a factor, i.e., ball joints and telescopic units - better seals. All systems work well if properly installed and adjusted, and maintained."

Question 10 - Are there any problems installing systems?

"Improperly designed transom makes steering hookup difficult. Some standardization of parts needed."

"Replacement of system could be made easier if accessibility to cables were better. Cables are frequently embedded in styrofoam making replacement difficult and sometimes results in poor installation because cable tension is not proper."

"Difficult to get proper parts. Manufacturer often makes improper substitutions, i.e., smaller gauge cables - cables that are too long."

III. SUMMARY OF MIAMI, FLORIDA, INTERVIEWS

Sixteen marina mechanics were interviewed at widely spaced locations in the Miami, Key Biscayne area. The questions asked follow, with a discussion of responses:

1. Do you know of any accidents caused by steering failure?

Yes - 2 people

In one case, a boater in a 6-month-old 18-foot runabout rammed into a bulkhead when a nut came loose on his steering system. No serious damage occurred.

In the second case, a young boater hit a bridge after corrosion had limited the steering range. The boat would not steer fast enough to make a sharp turn and avoid collision.

Note: Four people mentioned that shift cables failed when the boat operator thought he was in forward, but actually was in reverse, or vice versa.

2. What improvements would you like to see made on steering mechanisms?

Sixty percent said they would like to see improvements in the following order of priority.

- a. Corrosion-proof fittings
- b. Better lubrication seals
- c. More lubrication fittings
- d. Better location for lubrication fittings (i.e., on end sleeves)
- e. Improved, non-hardening lubricant
- f. Stronger, better-designed motor connections and ball joints for larger tandom mounts.

4. Do you have any problems installing systems?

Yes - 75%

Problems listed in order or prevalence are:

- a. Inadequate part substitutions by manufacturer - often cables are too long or too light.
- b. Non-standard nature of many steering systems often forces mechanic to search for hard-to-find parts and thus he will use a less than ideal substitute part. This causes hard steering and excessive cable wear.
- c. If one part is bad, but cannot be located, it is sometimes necessary to change most of the system at great relative expense in order to get the system functioning properly. Customers tend to put pressure on dealers/mechanics to make repairs the cheapest way possible, and mechanics often worry about what the consequences may be.

A number of mechanics noted that steering units last, on the average, only two or three years under normal use. Few people are concerned with maintaining them or even giving the unit annual lubrication. Six interviewees admitted that they replace steering units in part or whole for a number of wealthier customers as a normal part of yearly service.

It appears that in Miami the attitude of boaters is to generally ignore steering mechanisms until they fail, and then replace them. Failures rarely result in accidents of any consequence, so boaters don't seem to worry about it. Most failures appear to happen directly after periods of disuse. The potential failure is usually discovered by an owner or mechanic before placing the boat in the water and it is repaired then.

IV. TYPE I FAILURES

Two complete failures are documented. Both are mechanical systems in which the steering cables had to be replaced since rust and corrosion made it impossible to steer the boat. Corrosion and rust seem to be greatest where the cable forms the steering arm at the stern of the boat. This is the area where exposure to water and weather are greatest. Another factor which contributes to deterioration of the cable at this point in outboard motor boats is the removal of the motor from the water when the boat is not in use. In some instances, tilting the motor up puts an undue strain on the steering cable causing the outer covering to tear or pull loose, consequently subjecting the inner cable to the elements. However, design modifications make it less likely that some of the newer systems will bind up in this manner.

All mechanics surveyed indicated that rust or corrosion was the principal cause of steering failure. There was also unanimous agreement that such failures could be substantially reduced by regular lubrication of the system, i.e., at least at the beginning and end of the boating season. Periodic visual inspection of the system was also recommended by eight mechanics. Freeze-ups of the steering due to rust or corrosion are common after long periods of storage. For example, most steering failures of this type occur in the early spring after the boat has been stored for the winter. Failures due to rust or corrosion rarely lead to accidents because the owner must have the condition corrected before the boat can be used.

V. TYPE II FAILURES

One partial failure is documented in this survey. A defective system does not accompany this documentation because only a minor adjustment to the system was required to correct the condition.

VI. TYPE III FAILURES

No Type III failures are documented.

VII. FAILURES THAT RESULTED IN ACCIDENTS OR NEAR ACCIDENTS

No documented incident of a steering failure that caused an accident or near accident is included in this survey. Failures of mechanical systems that result in accidents are apparently extremely rare. One mechanic reported a case where the steering cable broke nearly causing an accident. Two mechanics reported incidents where quick couplers on steering arms failed and minor accidents resulted. One mechanic reported that he knew of several instances in the past 25 years where cables on tiller/cable systems snapped causing the boat to veer sharply to one side or even capsize. One such accident in Georgia involved a fatality. The other mechanics interviewed did not know of any accidents or near accidents caused by steering failure and it was their opinion that operator error, not mechanical failure, was the greatest single factor in boating accidents.

VIII. OTHER TYPES OF STEERING FAILURE OR PARTIAL FAILURE

The survey indicated five other types of failure or partial failure. These are listed below.

1. In an effort to free a "frozen system" the operator turns the steering wheel with sufficient force to break the gears in the helm assembly or snap the steering cable.
2. "Hard steering" resulting from rust or corrosion of the steering cable. This condition can be corrected by lubrication of the unit; however, if left unattended, the result is usually total system failure.
3. Improper installation of the steering system by boat manufacturer can result in steering failure. The result is a less responsive system; total steering system failure can occur if the cable binds under these conditions.
4. Tiller/cable systems are more prone to failure than mechanical systems because they are more complex. For example, tension of the steering cables must frequently be adjusted. If the cables are too tight, the pulleys give way. Conversely, if there is insufficient tension, the cables step off the pulleys causing the steering to bind and sometimes snap the cable. Further, the entire system is more exposed, thus increasing the likelihood of rust or corrosion.
5. Partial steering failure can be the result of improperly adjusted trim tabs.

IX. MECHANICS' RECOMMENDATIONS

The mechanics interviewed made the following recommendations:

1. Periodic lubrication of the steering systems will substantially reduce rust and corrosion and the probability of steering failures. Systems should be lubricated according to use and conditions, but always at the beginning and the end of the boating season.
2. Components exposed to salt water or weather should be made of brass or stainless steel whenever possible.
3. When not made of corrosion-proof metal, the exposed parts of the mechanism should be covered with grease or rinsed with clear water.
4. Cables should be kept away from the exhaust manifold since heat speeds deterioration.
5. The system should be inspected visually each time the boat is used.
6. Steering system parts should be standardized within the boating industry. This would eliminate poor substitutions.

7. **Manufacturers should improve quality control on factory-installed systems. A large number of systems are poorly installed, and often with wrong-part substitutions.**
8. **Trim tab adjustment can greatly affect the way a boat steers. Adjustment is often overlooked or avoided as it can be time consuming and is usually made by trial and error. A better trim tab adjustment methodology should be developed.**
9. **Improved lubrication seals could be an important way of increasing required service intervals.**
10. **Lubricants often harden due to salt and dirt buildup. There appears to be an actual chemical change in most grease after a period of disuse. The material becomes so hard that it can freeze up a system which is not otherwise very corroded. Perhaps improved silicone lubricants could be tested to see if they harden.**

APPENDIX D

OUTBOARD MOTOR REMOTE STEERING SYSTEMS
ABYC PROJECT P-17

LIST OF ILLUSTRATIONS

<u>Figure</u>		<u>Page</u>
1	Motor Mounted Steering	D-6
2	Steering Output Ram	D-7
3	Boat Mounted Steering	D-8
4	Steering Shafts and Steering Wheel Hubs	D-9
5	Wheel Description	D-10
6	Steering Wheel Impact Test Fixture	D-10

OUTBOARD MOTOR REMOTE STEERING SYSTEMS

PROJECT P-17 (PROPOSED OCTOBER 21, 1974)

ABYC P-17-74

Based on ABYC's assessment of the state of existing technology and the problems associated with achieving the requirements of this standard, ABYC recommends compliance with this standard by August 1, 1977.

P-17.1. PURPOSE

These standards and recommended practices, establish minimum strength requirements of remote steering systems and the major component items thereof, and are to facilitate safe connection of boat steering systems to outboard motors.

P-17.2. SCOPE

These standards and recommended practices apply to remote steering systems used with single outboard motor installations of 20 horsepower to and including 150 horsepower. These standards and recommended practices do not apply to cable over independently mounted pulley steering systems.

P-17.3. DEFINITIONS

- a. *Steering System* – An assembly including all components necessary to transmit remote manual effort to and including the steering output ram.
- b. *Minimum Steering Ability* – Steering capability after test such that the steering system must turn the outboard motor, under static conditions, through an arc of at least 5 degrees each side of the mid-position with no more than 20 foot-pounds of torque at the helm exerted through the wheel or other normal control. These limits are not meant to define a condition under which a boat can or cannot be safely operated, but are intended to provide quantitative limits for design and testing purposes.
- c. *Total Steering Loss* – Complete loss of the ability to steer the boat from the helm position by application of manual effort to the wheel or other helm control provided.

P-17.4. REQUIREMENTS – IN GENERAL

- a. This standard provides requirements for two steering systems with respect to the attachment at the output end:
 - (1) Motor mounted steering system.
 - (2) Boat mounted steering system.
- b. The steering system selected shall be installed in accordance with this standard.
- c. The interface between the outboard motor and the steering system shall be the attachment point at the output end as shown in Figure 2.
- d. Steering system threaded fasteners, the integrity of which is necessary to the maintenance of steering control, shall have a locking feature to prevent loosening which should be of a type that will preclude accidental omission during field installation or maintenance.

P-17.5. REQUIREMENTS – OUTBOARD MOTORS

- a. The steering stops on the outboard motor shall permit at least 30 degrees of angular movement either side of center.

(P-17.5)

- b. Outboard motors where applicable shall incorporate the dimensional requirements indicated in Figure 1.
- c. The outboard motor shall include the necessary fittings to attach to the steering output ram as shown in Figure 2.
- d. The outboard motor shall be designed so there shall be no damaging interference between the motor, its accessories, and both the boat mounted system installed as shown in Figure 3 and the motor mounted system, provided the motor is designed for both systems. Appropriate written information and installation instructions shall be provided, clearly indicating the type of steering system(s) that should be used. Motors may be designed for special steering systems providing the non-standard components are provided with the motor along with the necessary installation information.
- e. Outboard motors shall be designed with geometry to insure that a static load of 750 pounds, applied at the steerer connection point normal to the steering arm in its normal place of operation, throughout the maximum steering arc, will not result in steering output ram loadings greater than those specified in ABYC P-17.8.b.(1).

P-17.6. REQUIREMENTS - STEERING SYSTEM

- a. Motor mounted steering systems shall incorporate the dimensional requirements indicated in Figure 2.
- b. Boat mounted steering systems shall incorporate the dimensional requirements indicated in Figures 2 and 3.
- c. Quick-disconnect fittings relying upon spring force for connection integrity shall not be used.
- d. Steering cables shall be marked with a steering system length which shall be the length from the center of the steering wheel shaft to the end of the steering output ram at the mid-travel position.
- e. Steering helm manufacturers shall indicate the maximum diameter and deepest dish wheel, (See Figure 5) which may be used with the helm, in appropriate written information, including installation instructions. In addition, this information shall be permanently marked on the helm assembly so as to be visible when the helm is installed with the wheel removed.

P-17.7. REQUIREMENTS - INSTALLATION

- a. Steering System installers shall select either the Motor Mounted Steering System or the Boat Mounted Steering System unless the installation is specifically intended for outboard motors having special requirements.
- b. When installing Motor Mounted Steering Systems in outboard boats, steering cables shall be selected which, as installed, at mid-travel position, will reach at least 10 1/2 inches beyond the motor centerline.
- c. When installing Boat Mounted Steering Systems in outboard boats, steering cables shall be selected which, as installed, at mid-travel position, will reach at least to the motor centerline. The cable shall be attached to the boat so as to position the cable anchor swivel with respect to the transom motor centerline as specified in Figure 3.
- d. Steering cable bend radii and total degrees of bend, as installed, shall comply with cable manufacturer's recommendation.

(P-17.7.)

- e. Steering System installers shall select matching steering wheels and heim shafts. Current fit configurations are shown in Figure 4.

P-17.8. **REQUIREMENTS - TESTING**

- a. *As Installed Tests* - These tests are intended to establish the acceptability of the strength of steering systems, as installed, in a boat to the interface with the outboard motor as defined in ABYC P-17.4.c.

- (1) Steering systems shall withstand static loads in either direction of 750 pounds applied at the connection hole of the steering output ram along the axis of the steering output ram without deformation that, following this test, will cause any loss in steering capability or cause dimensional change that will result in non-compliance with Figure 3. The permanent deformation shall not exceed .25 inches measured along the axis of the output ram.
- (2) Steering systems shall withstand tangential loads in either direction of 100 pounds applied at any point on the steering wheel rim, and separate axial loads of 150 pounds in either direction, distributed over 4 inches of rim at any location maintaining minimum steering ability.

- b. *Component Tests* - These tests are intended to establish acceptable minimum design criteria for components of steering systems.

- (1) Steering output and cable assemblies (including boat mounted system hardware) and their integral fittings shall withstand a load of 2000 pounds in tension and compression, applied at the connection hole of the steering output ram, throughout the travel range without severance of components. A separate cantilever load of 200 pounds shall be applied at the centerline of the hole in the steering output ram with at least 7 1/2 inches of the ram unsupported without more than .05 inches of permanent deflection at the ram hole.
- (2) Steering output assemblies of steering systems not using push-pull cables, or cable over independently mounted pulley systems, shall withstand the same loadings specified in ABYC P-17.8.b.(1).
- (3) Helm assemblies shall incur no loss of operating function after the following tests when equipped with the largest diameter and deepest dish steering wheel for which the helm is rated.
 - (a) **Axial Load Test** - A 150 lbs. push-pull load shall be applied for 10 cycles at a duration of 5 seconds per loading, applied at any location on the rim of the wheel in a direction parallel to the axis of the steering shaft.
 - (b) **Tangential Load Test** - A 100 lbs. push-pull load shall be applied tangentially in the plane of the steering wheel for 10 cycles at a duration of 5 seconds per loading, applied at any location on the rim of the wheel at any point in its total steering range.

- (4) Steering wheels shall be subjected to 3 cycles of thermal conditioning before mechanical tests are performed. 1 cycle of thermal conditioning is defined as:

3 hours at 70° ± 3°F (21° ± 2°C)

3 hours at -30° ± 3°F (-34° ± 2°C)

3 hours at 70° ± 3°F (21° ± 2°C)

3 hours at 160° ± 3°F (71° ± 2°C)

At the conclusion of the thermal cycling, parts shall exhibit no visible degradation of structural components, except for minor cracking of plastic.

[P-17.8.b.(4)]

At a temperature of 68°-75°F (20°-24°C), for at least 3 hours, the wheels shall then in sequence withstand the following mechanical tests.

- (a) **Axial Test** - A 150 lbs. push-pull load, distributed over 4 inches of the rim at any location shall be applied for 10 cycles at a duration of 5 seconds per loading without fracture or permanent deformation in excess of 1 inch at the rim.
- (b) **Tangential Load Test** - A 100 lbs. push-pull load at any location on the rim shall be applied tangentially in the plane of the steering wheel for 10 cycles at a duration of 5 seconds per loading without fracture.
- (c) **Impact Load Test No. 1** - Wheels shall withstand a single impact of 120 foot lbs. at any location on the rim without propagation of any cracks induced by thermal cycling, appearance of new cracks or deformation that would cause loss of minimum steering ability when installed on a steering system. [See ABYC P-17.8.b.(5) and Figure 6 for impact test fixture. (h = 8.25 inches)]
- (d) **Impact Load Test No. 2** - Wheels shall withstand a single impact of 200 foot lbs. at any location on the rim without sustaining total steering loss when installed on a steering system. [See ABYC P-17.8.b.(5) and Figure 6 for impact test fixture. (h = 13.75 inches)]
- (5) The impact test fixture shall comprise a leather bag of 10" diameter completely filled with 175 pounds of lead shot suspended on a free swinging cable such that the center of mass shall be 90 ± 6 inches below the supporting pivot. The impact face of the bag shall be a 10 inch diameter end. The bag shall be elevated through sufficient arc to impart the desired value of impact upon a rigidly mounted steering wheel by swinging the bag as indicated in Figure 6. Other devices than that specified, such as a falling weight bag, may be used providing equivalency can be verified.

c. **Corrosion Testing** - This test is intended to establish acceptable minimum corrosion resistance for steering systems. Tests shall be conducted on 5 feet of the output end of an assembled steering system under cyclic test conditions. Assemblies shall be lubricated according to steering system manufacturer's specifications and installation instructions, but no additional lubrication may be used after commencement of testing.

(1) **Test Procedure** -

- (a) Exposed elastomer sheathing and seals shall be subjected to radiation with an intensity of 60 - 75 microwatt per square centimeter at 340 nanometer wave length for 200 hours prior to corrosion testing.
- (b) The cable assembly with the output end shall be placed in the test chamber in a horizontal position with all covers or protective sleeves in place.
- (c) The environmental test shall be conducted and prepared for evaluation in accordance with ASTM B117-73 (ANSI Z118.1) Standard Method of Salt Spray (Fog) Testing.
- (d) The length of the test shall be a minimum of 200 hours.

[P-17.8.c.(1)]

- (e) The cyclic sequence for operation of the steering system during salt spray testing shall be 4 hours of 4 to 6 cycles per minute of at least 6 inches of cable travel during every 24 hour period under a minimum compression load of 50 lbs.
 - (f) At the conclusion of the 200 hour exposure period, the individual components shall be examined for evidence of corrosion, binding or other functional problems.
- (2) Evaluation of Test Results – Corrosion failure is defined as the appearance of pitting, scaling or surface buildup visible to the unaided eye at the normal reading distance on internal or external surfaces that have relative motion during operation or installation. Components shall perform their functions as originally designed.

© 1974 American Boat and Yacht Council, Inc.

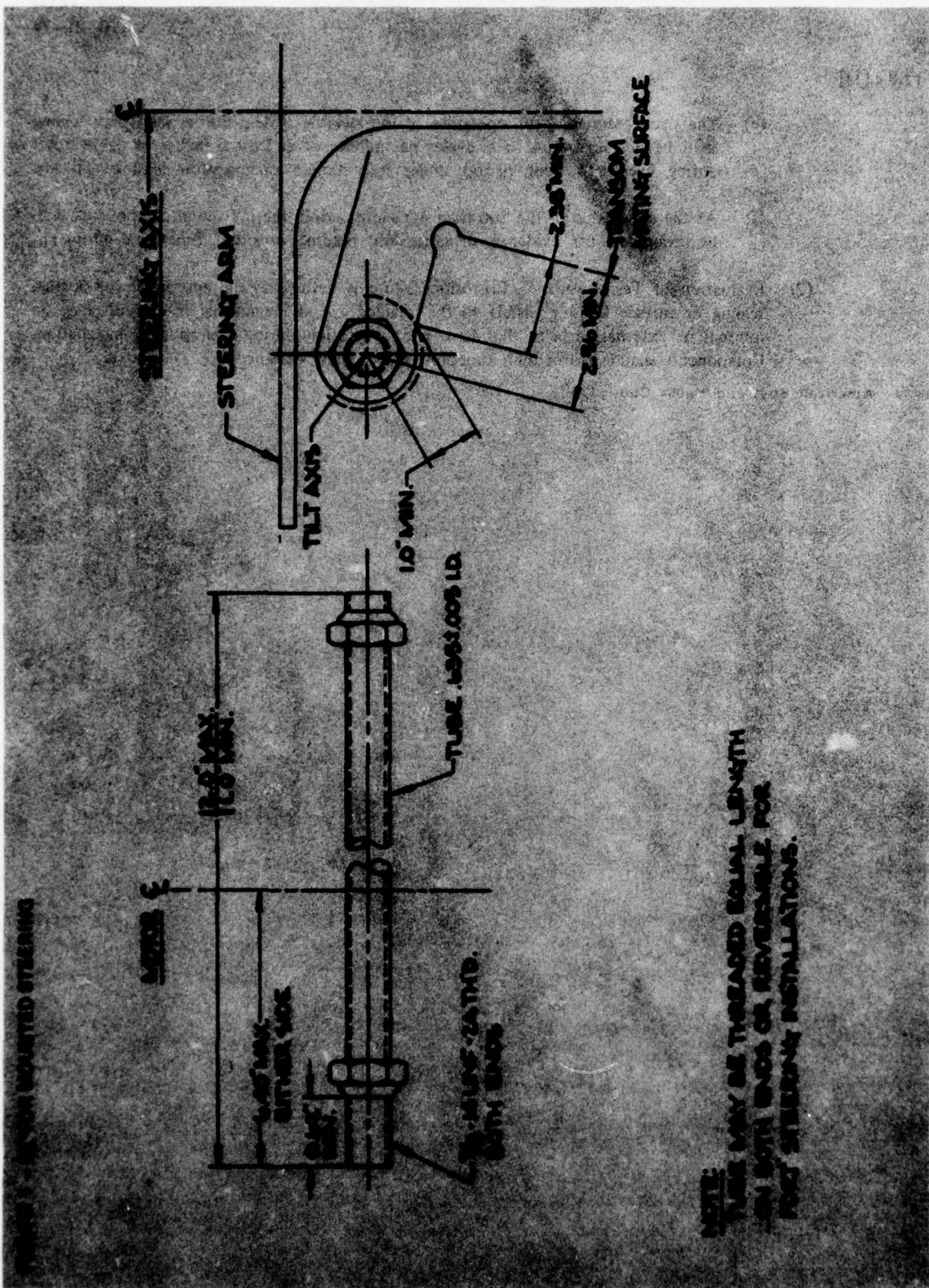

NOTE:
TUBE MAY BE THREADED EQUAL LENGTH
ON BOTH ENDS OR REVERSIBLE FOR
PORT STEERING INSTALLATIONS.

P-17 (1)
10-21-74

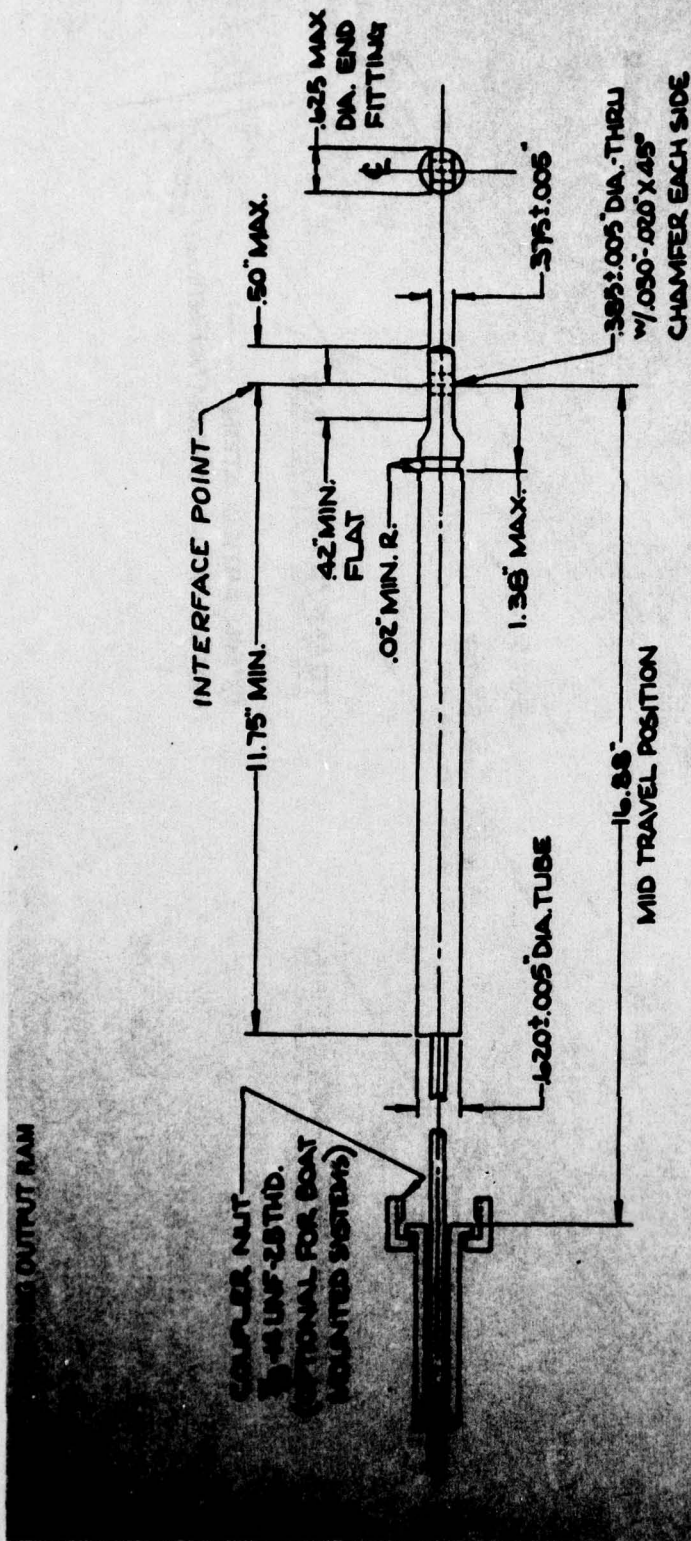

NOTE:

TRAVEL TO BE 8.5 ± 0.5"
MIN. TRAVEL 4.00" EACH SIDE
 OF MID TRAVEL POSITION
MAX. TRAVEL 4.50" EACH SIDE
 OF MID TRAVEL POSITION.

RAM OUTPUT RAM

COUPLER NUT
 3/8 UNF-25 THD.
 (OPTIONAL FOR BOAT
 MOUNTED SYSTEMS)

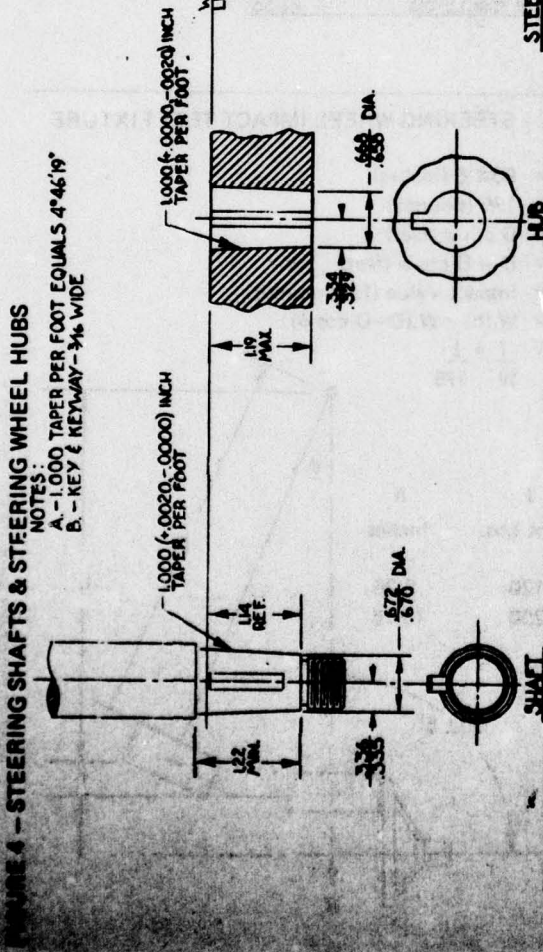
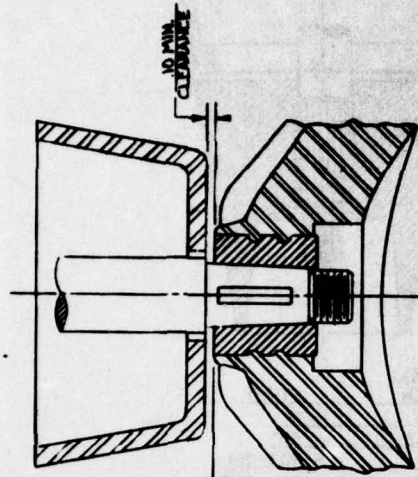
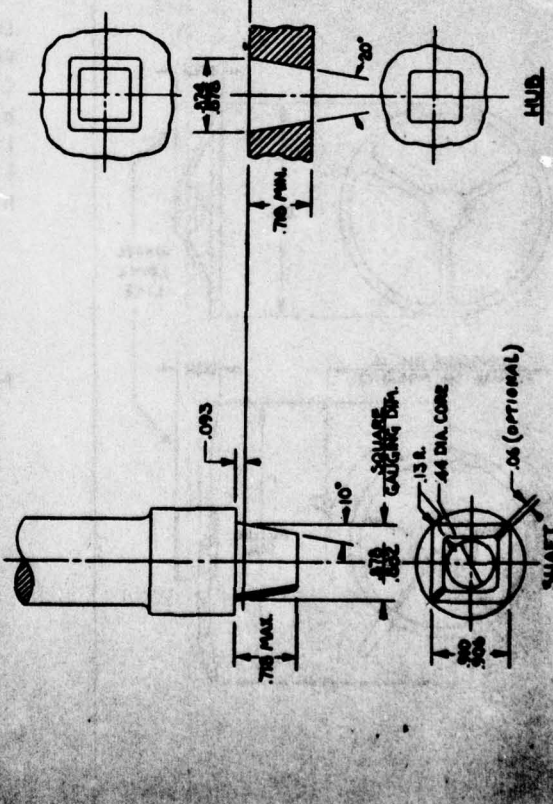
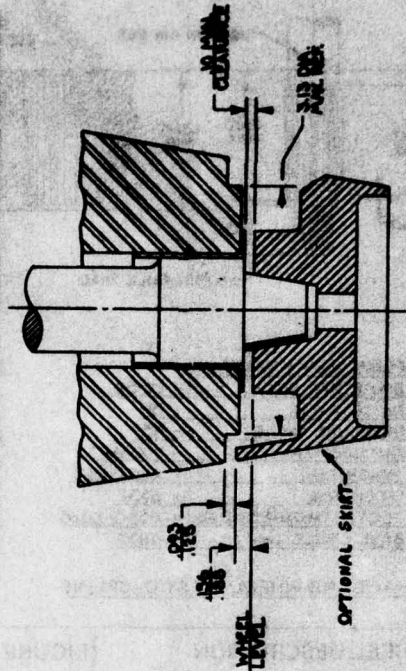

FIGURE 4 - STEERING SHAFTS & STEERING WHEEL HUBS

NOTES:

- A. - 1.000 TAPER PER FOOT EQUALS 4" 46' 19"
- B. - KEY & KEYWAY - 3/16" WIDE

STEERING SHAFT AND WHEEL FIT STD. 1.00 INCH/FOOT TAPER



STEERING SHAFT AND WHEEL FIT STD-TAPERED SQ.

FIGURE 4 CONTINUED ON PAGE 10

FIGURE 4 - (CONTINUED)

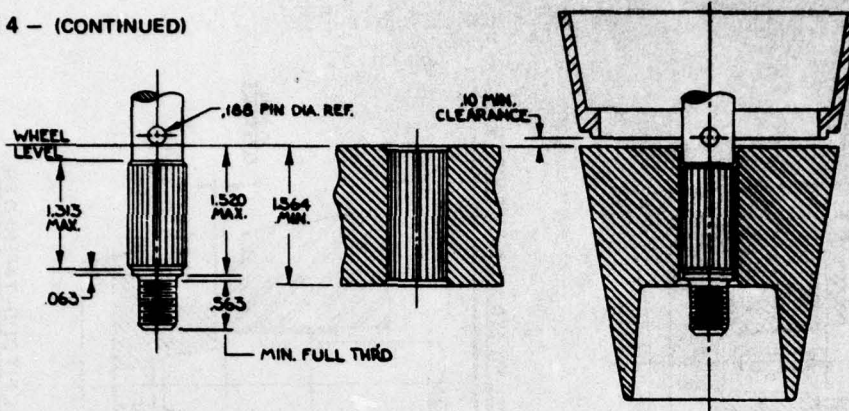

SPLINE DATA - SHAFT:

DIAMETRAL PITCH	- 29-36
NO. OF PITCH	- 19
PRESSURE ANGLE	- 45°
OUTSIDE DIA.	- 700-687
MINOR DIA.	- 6207-6167
PITCH DIA.	- 6552
TOOTH THICKNESS @ P.D.	- 0580-0565
BASE CIRCLE DIA.	- 4633

SPLINE DATA - WHEEL:

DIAMETRAL PITCH	- 29-36
NO. OF TEETH	- 19
PRESSURE ANGLE	- 45°
OUTSIDE DIA.	- 703-701
MINOR DIA.	- 636-630
PITCH DIA.	- 6552
TOOTH THICKNESS @ P.D.	- 0660-0652
BASE CIRCLE DIA.	- 4633

STEERING SHAFT AND WHEEL FIT ST'D-SPLINE

FIGURE 5 - WHEEL DESCRIPTION

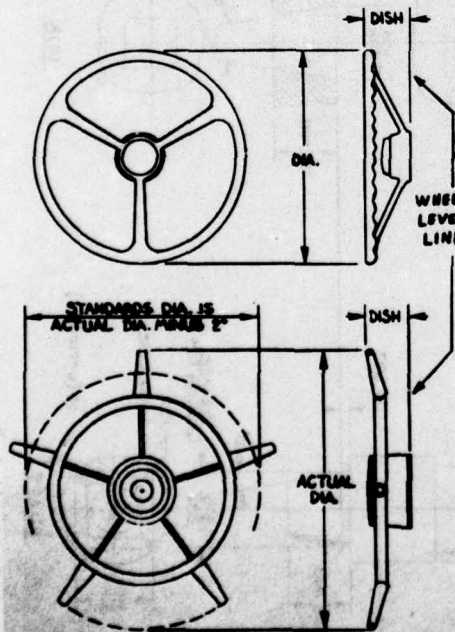
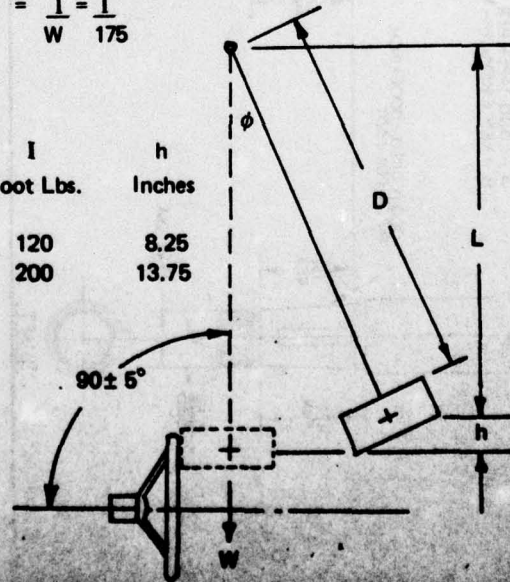

FIGURE 6 - STEERING WHEEL IMPACT TEST FIXTURE

- D = 90 ± 6 (inches)
- W = 175 (pounds)
- L = D cos φ (feet)
- h = D - D cos φ (feet)
- I = Impact Value (foot pounds)
- I = W (h) = W (D - D cos φ)
- $h = \frac{I}{W} = \frac{I}{175}$

I	h
Foot Lbs.	Inches
120	8.25
200	13.75



APPENDIX E

**RECREATIONAL BOAT
STEERING SYSTEM TESTING**

M. L. Vande Steeg

**Prepared for
U. S. COAST GUARD
Contract DOT-CG-81-74-1098**

**OUTBOARD MARINE CORPORATION
Marine Engineering - Engine Section**

August 1974

ABSTRACT

This project was initiated in response to a Coast Guard Procurement Request #81-0713-74. Current OMC push-pull steering systems were tested both dynamically and statically. Steering loads under actual operating conditions were measured using the following boat-engine configurations:

1. 19-foot Evinrude boat equipped with dual 135 hp outboards
2. 19-foot Evinrude boat equipped with a single 225 hp inboard/outboard
3. 24-foot Wellcraft boat equipped with dual 165 hp inboard/outboards

Static loads were applied to the following steering systems:

1. thru-tilt single 50 hp
2. thru-tilt single V-4
3. transom mounted single V-4
4. thru-tilt dual 50 hp
5. thru-tilt dual V-4

Critical deflections were recorded along with the level of loading that caused system failure.

CONTENTS

Abstract	ii
List of Illustrations	iv
List of Tables	v
I. INTRODUCTION	1
II. DYNAMIC TEST PHASE	2
A. Equipment	2
B. Results	8
C. Discussion	12
III. STATIC TESTING	13
A. Equipment	13
B. Results	13
1. Single V4 Transom Mounted	13
2. Single 50 hp Thru-Tilt	15
3. Dual 50 hp Thru-Tilt	17
4. Single V4 Thru-Tilt	19
5. Dual V4 Thru-Tilt	24
6. Dual Engine Single Cable	27
7. Static Vs. Simulated Impact Loads	28
C. Discussion	31
IV. SUMMARY	32
APPENDIX A - Dynamic Test Data	34
APPENDIX B - Static Test Data	53
APPENDIX C - Steering System Load Analysis	70

LIST OF ILLUSTRATIONS

<u>Figure</u>		<u>Page</u>
1	Dual 135 hp Outboard	3
2	Steering Arm Load Cell	4
3	Stern Drive Steering Bracket Load Cell	5
4	Stern Drive Steering Bracket	6
5	Peak Dynamic Loads	11
6	V4 Swivel Brackets with Loading Arms	14
7	Steering Assembly	21
8	Steering Load Vs. Ram Deflection	22
9	Simulated Impact Steering Loads - Compression	29
10	Simulated Impact Steering Loads - Tension	30

LIST OF TABLES

<u>Table</u>		<u>Page</u>
1	Dynamic Test Data	9
2	Dual 50 hp Steering Load Distribution	18
3	Cable Extension/Compression	23
4	Ram Bending	23
5	Dual V4 Steering Load Distribution	26

I. INTRODUCTION

The project on which this report is based had a dual purpose. It included making dynamic measurements of the loads induced in recreational boat steering systems and testing certain steering systems under static loads to determine the level of loading that would cause impairment or failure of the system.

The dynamic tests were designed to measure the steering loads under the most severe conditions. Driver safety was a factor in determining the types and severity of maneuvers performed with each boat; however, in general they included wave-jumping with high-speed prop re-entry and high-speed turns including total spin-outs. All of the test runs would be considered abusive-type driving. In addition, the 135 hp outboards were operated with a misadjusted trim geometry.

The static tests were structured so as to define the steering system geometry that would place a maximum load on the member of the system that will fail initially under increasing loads. Critical deflections were measured under various loads to determine the level of loading that causes the onset of permanent deflection and that which causes failure of the system to function throughout its normal range. Whenever possible, the systems were misadjusted to ascertain the worst possible condition.

II. DYNAMIC TEST PHASE

A. Equipment

The following boat-engine configurations were tested:

1. 19-foot Evinrude equipped with dual 135 hp outboards
2. 19-foot Evinrude boat equipped with a single 225 hp inboard/outboard
3. 24-foot Wellcraft boat equipped with dual 165 hp inboard/outboards

The dual outboard installation was rigged with dual push-pull steering cables and a tie-bar. Figure 1 is a photograph showing the dual thru-tilt steering system that was used. The steering loads were measured using a strain gage bending bridge mounted on machined sections of the steering arms, as shown in Figure 2. This arrangement allowed steering torque to be determined directly from the load cells.

The dual inboard/outboard installation was rigged with a single push-pull cable and a tie-bar. The steering bracket that mounts on the outdrive was replaced with one that was designed to accommodate a strain gage bending bridge. This load cell is shown schematically in Figure 3. It was designed in such a manner that the steering load would be measured as a torque about the outdrive swivel axis.

The single inboard/outboard was equipped with an external push-pull steering system. The same load cell that was used for the dual installation was mounted on the outdrive. Figure 4 is a photograph of the bracket. Again, the steering load was measured as a torque about the outdrive swivel axis.

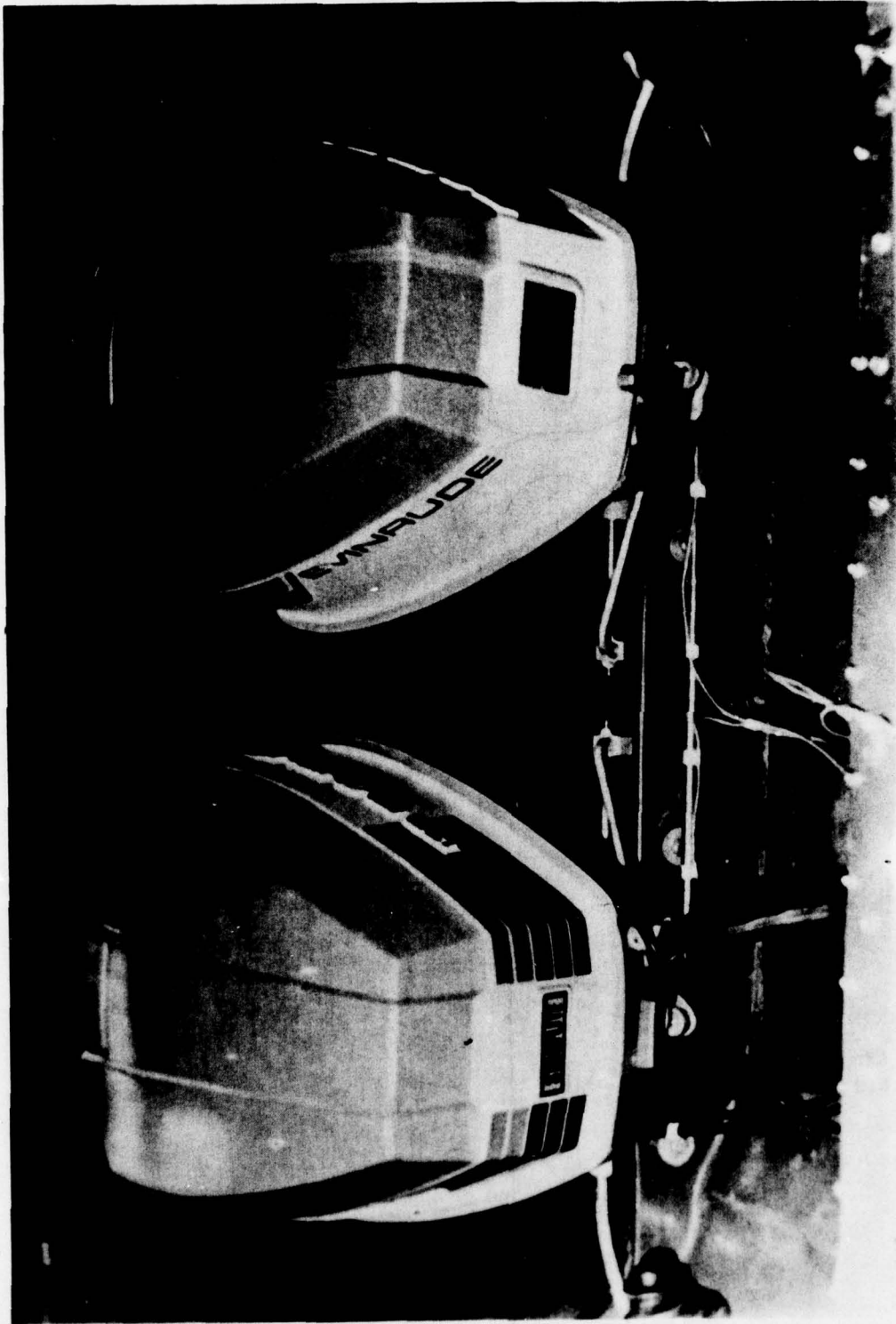
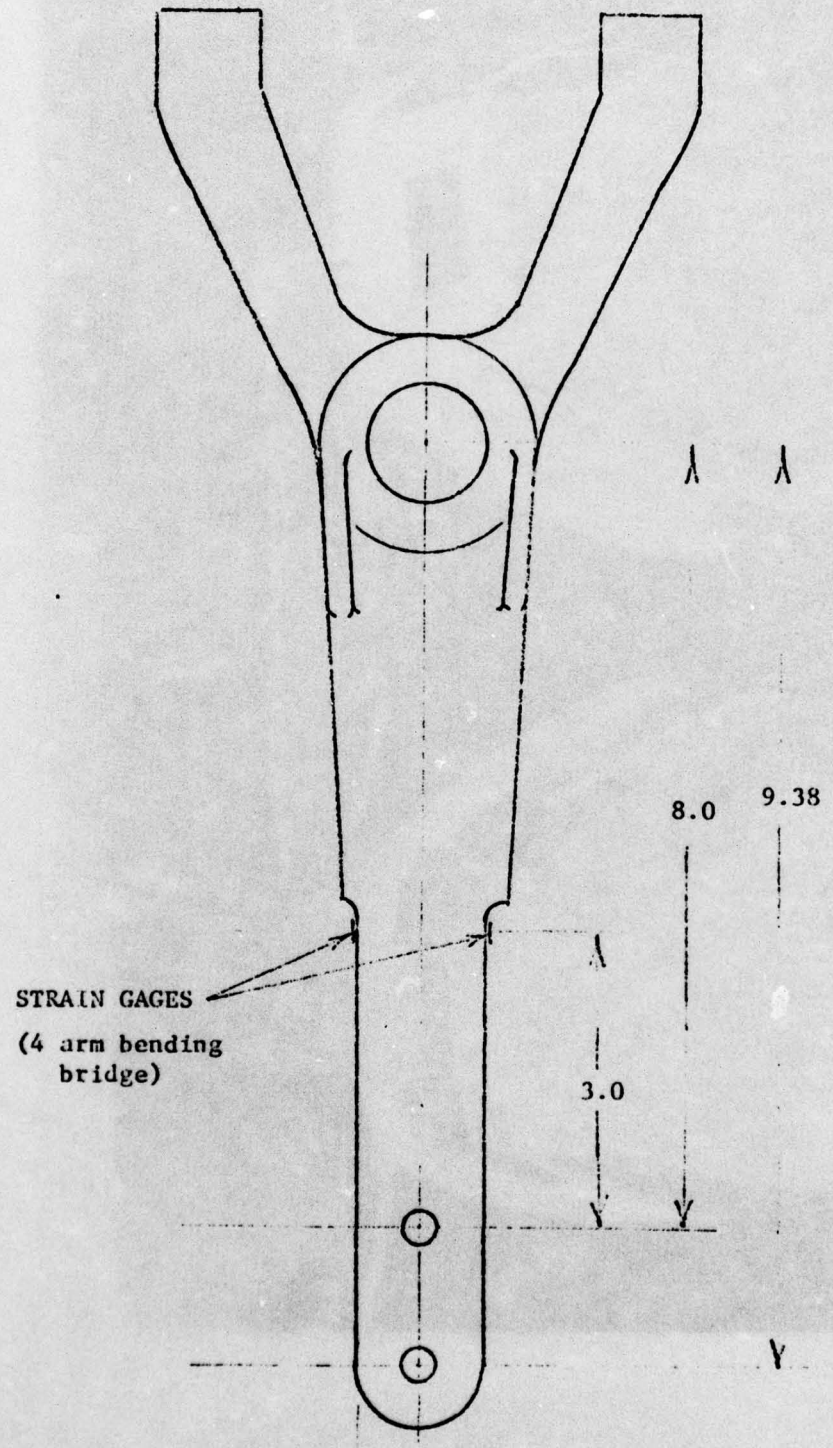

FIGURE 1. Dual 135 hp Outboards.

STEERING ARM LOAD CELL



< 1.29 >

E-10

FIGURE 2

STERN DRIVE STEERING BRACKET LOAD CELL

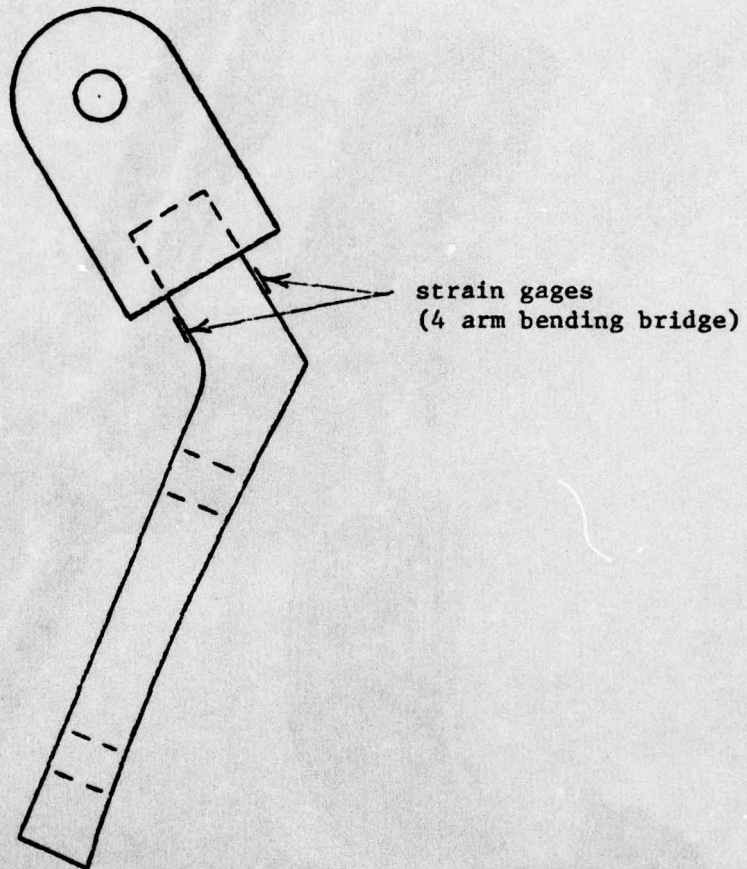

stern drive swivel axis

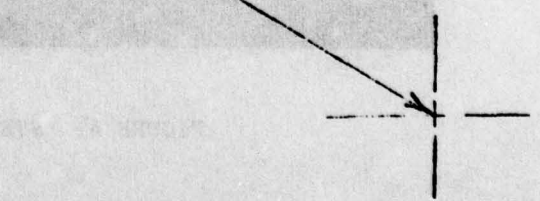

FIGURE 3
E-11

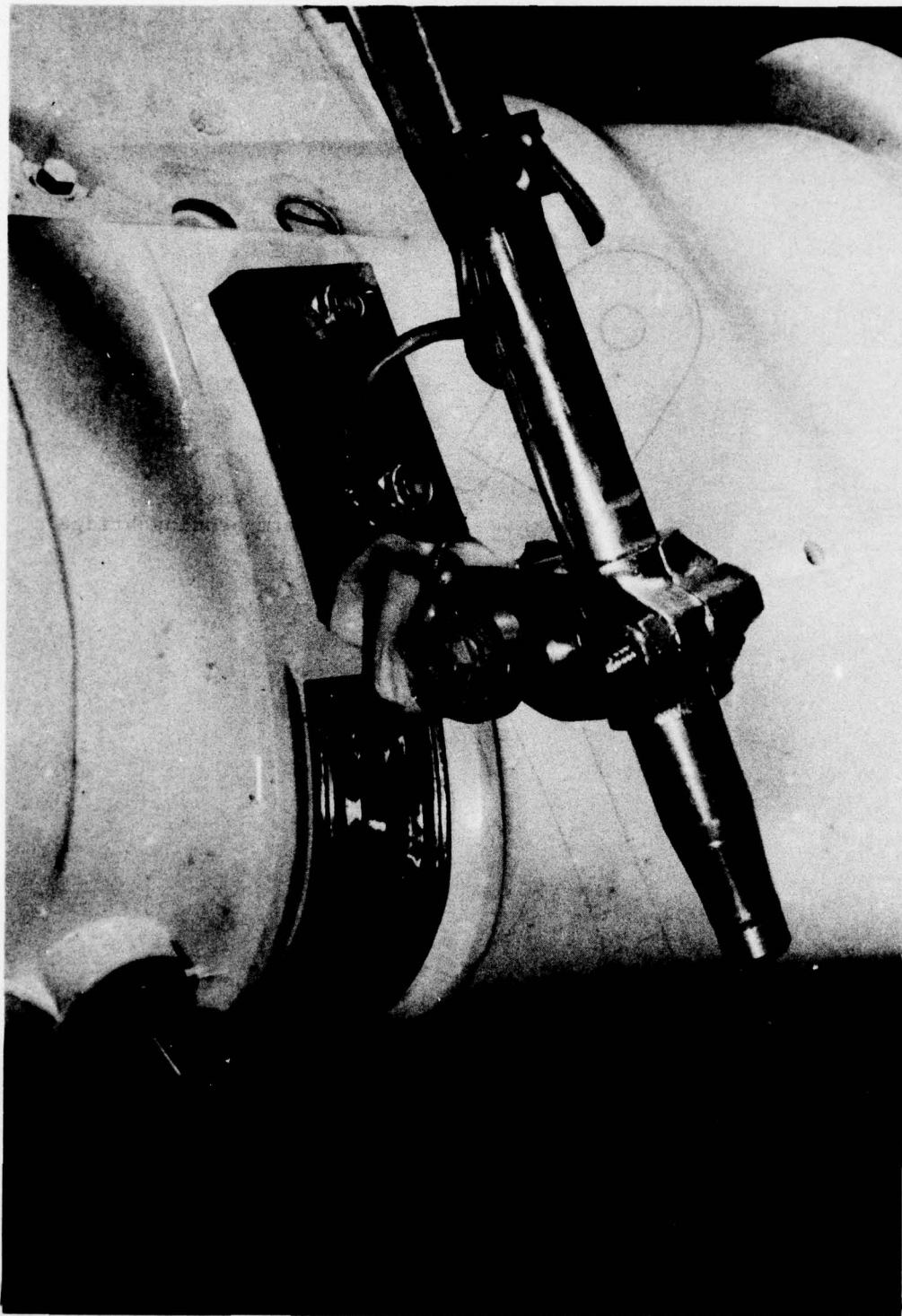

FIGURE 4. STERN DRIVE STEERING BRACKET.

II. DYNAMIC TEST PHASE

A. Equipment (continued)

A portable power supply that operates from a 12-volt auto battery was used to power the strain gage bridges and Dana amplifiers that condition the bridge signals.

A magnetic pick-up that sensed the armature magnets in the flywheel was used to provide engine rpm data for the outboard engines. On the inboard engines, an attenuated signal from the ignition coil was used to provide the engine speed data.

On all of the boats, a rotary potentiometer was coupled to the steering wheel shaft. It was wired into a bridge-type circuit powered by a 9-volt battery and used to record the steering wheel position.

A pitot tube and gauge provided the operator with boat speed information.

A portable Lockheed magnetic tape recorder was used to record all of the data. In addition, a headset was utilized to allow the driver to record on the voice track any information that he felt was pertinent to the testing.

II. DYNAMIC TEST PHASE (continued)

B. Results

The dynamic test data was recorded on magnetic tape and later played back into a Visicorder. Appendix A contains a number of sample Visicorder traces, along with pertinent calibration information. Table 1 lists the maximum load for each boat and the conditions under which the loading occurred.

The steering loads are indicated as being in foot-pounds of torque. This is the torque caused by the engine or outdrive about its swivel axis. Indicating the load in this manner eliminates the need for relating a force to its moment arm and to the angle that it forms with a line normal to the steering arm or bracket. Due to the tie-bar and single steering cable, the torque of the dual inboard/outboard installation was automatically summed at the load cell. The torques produced by dual outboards were recorded individually and then summed electronically during playback.

The dual outboards were initially tested in a normal tilt position. The engines were then tilted out past the normal operating range. As shown in Table 1, the maximum steering load increased from 505 foot-pounds to 600 foot-pounds. When an outboard engine is tilted out past the optimum tilt position, the boat tends to "porpoise," which accentuates the wave-jumping action. If the boat is turned at the same time as it is porpoising, the steering loads are very high.

DYNAMIC TEST DATA

BOAT	ENGINE HP	AMBIENT			TYPE OF DRIVING	MAXIMUM LOAD FT-LBS	BOAT SPEED MPH	ENGINE RPM	STEERING POSITION	TILT ANGLE
		WIND MPH	TEMP. °F	WATER*						
19'	DUAL 135	0-5	40	MODERATE	WAVE JUMPING	505	42	5000	0°	-2°
19'	DUAL 135s	0-5	40	MODERATE	WAVE JUMPING	600	45	5400	10° STBD	9°
19'	I/O 225	10	30	MODERATE TO LIGHT	HARD TURN	285	45	5400	22° STBD	0°
24'	DUAL 165 I/O	0-10	36	MODERATE TO HEAVY	WAVE JUMPING	360	45**	4800	0°	-3°

* moderate water condition indicating 2 to 3-foot swells

** estimated

TABLE 1

II. DYNAMIC TEST PHASE

B. Results (continued)

The 24-foot Wellcraft was tested in relatively rough water. The boat could readily be jumped out of the water; however, the boat did not lend itself to hard turns of any type. The driver's seat was elevated and had little side support. Also, a fuel tank and motor mount were torn from their supports during the testing. Adding any side impacts to the testing maneuvers would undoubtedly have caused additional damage to the boat. The maximum load on the steering system was 360 foot-pounds of torque. The maximum load on the single inboard/outboard steering system, 285 foot-pounds, occurred during a high speed turn. The boat nosed down while entering the turn, causing the rear of the boat to raise up and spin around. As the rear of the boat dropped back into the water, it caused a high side impact on both the boat and outdrive.

The maximum loads on the steering systems are of relatively short duration. Figure 5 shows the peak loads on the same time axis to illustrate the impact nature of the loads. The short duration of the peak loads, combined with the friction and mechanical advantage of the system, causes little (if any) of the load to be felt at the steering wheel.

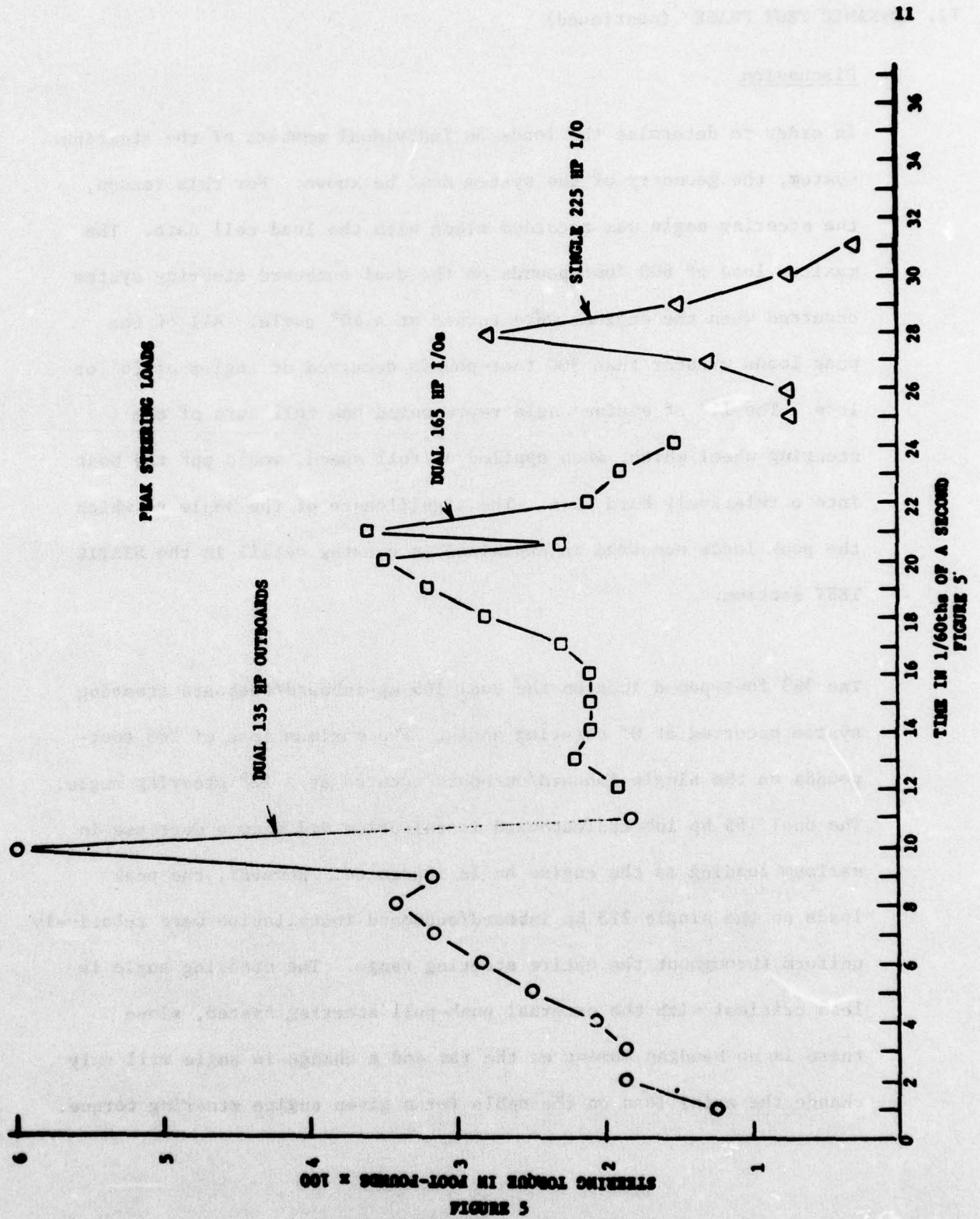

II. DYNAMIC TEST PHASE (continued)

C. Discussion

In order to determine the loads on individual members of the steering system, the geometry of the system must be known. For this reason, the steering angle was recorded along with the load cell data. The maximum load of 600 foot-pounds on the dual outboard steering system occurred when the engines were turned at a 10° angle. All of the peak loads greater than 300 foot-pounds occurred at angles of 16° or less. The 16° of engine angle represented one full turn of the steering wheel which, when applied at full speed, would put the boat into a relatively hard turn. The significance of the angle at which the peak loads occurred is explained in greater detail in the STATIC TEST section.

The 360 foot-pound load on the dual 165 hp inboard/outboard steering system occurred at 0° steering angle. The maximum load of 285 foot-pounds on the single inboard/outboard occurred at a 22° steering angle. The dual 165 hp inboard/outboard installation did show a decrease in maximum loading as the engine angle increased. However, the peak loads on the single 225 hp inboard/outboard installation were relatively uniform throughout the entire steering range. The steering angle is less critical with the external push-pull steering system, since there is no bending moment on the ram and a change in angle will only change the axial load on the cable for a given engine steering torque.

III. STATIC TESTING

A. Equipment

All of the static steering systems testing utilized a 19-foot Evinrude boat. The steering systems were installed in a normal manner, except that the steering wheel was replaced with a steel bar to facilitate locking the system at various engine angles.

The stern and swivel bracket assemblies, with the engines removed, were used in the static testing. Steel bars were bolted to the steering arms to apply the torque, which normally is transmitted through the engine. Figure 6 is a photograph of the dual V4 thru-tilt steering system with the arms used to load the system attached.

The torque input to the steering system was measured using a Dillon spring scale in line with the loading force. An axial load bridge was placed on the tie-bar to allow measurement of the load transmitted through the tie-bar on the dual installations.

B. Results

1. Single V4 Transom Mounted

The swivel bracket was placed in the 2° tilt position and loaded at various angles and all four elevations. Appendix B contains a complete listing of all of the data. Using a load of 560 ft-lbs, the only measurable deflection occurred in the push-pull cable. Depending upon the load direction, it would elongate or compress approximately .5 inch. There were no permanent deflections at this level of loading.

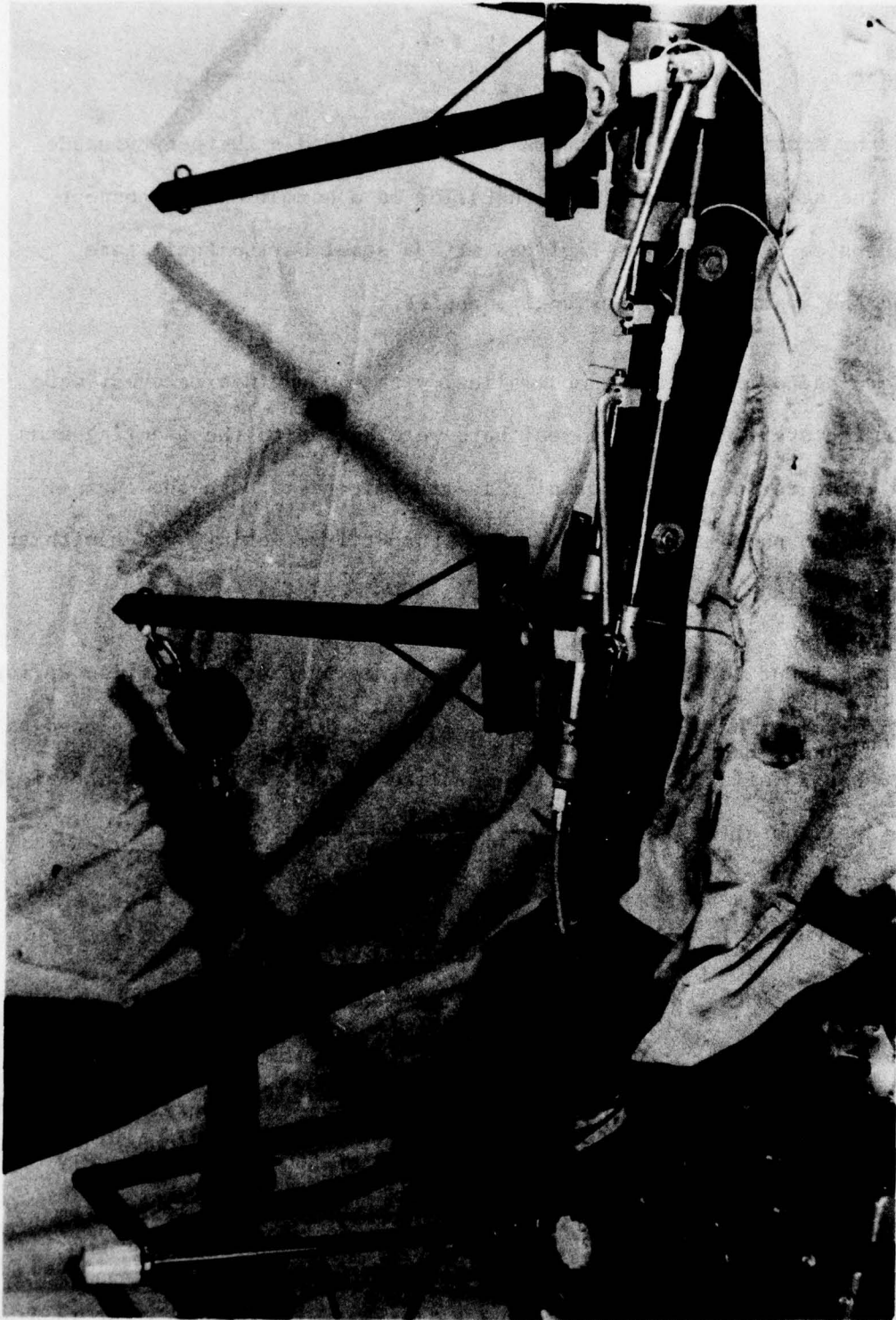

FIGURE 6. V4 SWIVEL BRACKETS WITH LOADING ARMS.

III. STATIC TESTING

B. Results

1. Single V4 Transom Mounted (continued)

To define the failure point, the ram was placed in its most vulnerable position. The engine was turned to a 32° angle, and the stern bracket was moved to the uppermost elevation. The torque was applied in a clockwise direction, which placed the steering ram in compression. The load was increased to 890 ft-lbs. At that point, the ram buckled, rendering the steering system inoperable. In addition, the transom bracket that supports the swivel ball had begun to separate under load.

2. Single 50 hp Thru-Tilt

The steering arm deflections were measured by attaching a pointer to the arm at the engine pivot point and directing it to a scribed point midway between the drag link and tie-bar attachment points. The steering arm deflection for all loads up to 620 ft-lbs was less than .06 inch.

The extended length of the ram measured both loaded and unloaded would be indicative of any compression or elongation of the cable. The cable compressed and elongated approximately .5 inch while under load.

The most critical loading in the system is the bending moment on the ram. According to an analysis of the 50 hp thru-tilt system, as outlined in Appendix C, the ram will have a maximum bending moment for a given torque when the engine angle is at 15°. The following fore-aft deflections of the ram were recorded:

III. STATIC TESTING

B. Results

2. Single 50 hp Thru-Tilt (continued)

<u>LOAD</u> <u>ft-lbs</u>	<u>DEFLECTIONS UNDER LOAD</u> <u>inches</u>	<u>PERMANENT DEFLECTIONS</u> <u>inches</u>
388	.75	.12
484	.75	.12
542	1.00	.19

The .12 and .19 inch permanent deflections caused a drag on the steering system. However, it was still operable throughout its entire range of travel. The ram appeared to be strain-hardening at this point. Therefore, it was replaced with a new ram and cable assembly. The engine angle was selected so that under loaded conditions, it would be at approximately 15°. The system was loaded to 620 ft-lbs. The ram deflected 1.5 inches under load with .62 inch permanent deflection. A permanent deflection of the ram of .38 inch or greater was considered a failure of the system since it could not be readily operated throughout its full range of travel. The amount of permanent deflection of the ram that a system can tolerate and remain operable may vary from engine to engine dependent upon the condition of the tilt-tube. A worn tilt-tube with rounded edges would be more tolerant of a bent ram than a new tilt-tube with less clearance.

III. STATIC TESTING

B. Results (continued)

3. Dual 50 hp Thru-Tilt

The dual engine dual cable system with the tie-bar is a statically and mathematically indeterminate system. If the fraction of the total load that each cable is bearing can be determined, the cable, ram, and drag link can be expected to respond as if they were a single engine carrying that particular load. The axial load cell on the tie-bar provided the lateral force acting on each steering arm. This force could be resolved into an axial force and a normal force for any steering angle. Knowing the normal force and the torque input into the system, the load on each assembly could be calculated. Table 2 illustrates the load distribution of the dual 50 hp installation.

The maximum load that either cable supports is 66% in either tension or compression. Using the information gained from the single 50 hp testing, this would indicate that the total loading on the system would have to exceed 500 ft-lbs before any permanent deflection of the ram would occur. This is indeed the case, as it took 775 ft-lbs to permanently deflect a ram .12 inch. Another factor that became apparent during this test series is the fact that as the total load is increased, it becomes more evenly shared between the cables. This tends to increase the load necessary for both the initial yielding and the point of failure. Obviously,

DUAL 50 HP STEERING
LOAD DISTRIBUTION

ENGINE LOADED	ENGINE ANGLE	LOAD FT-LBS	LOAD DIRECTION*	% OF TOTAL LOAD	
				18' CABLE	20' CABLE
STBD	0°	484	+	48	52
STBD	0°	484	-	66	34
PORT	0°	484	+	60	40
PORT	0°	484	-	46	54
STBD	25°	484	+	66	34
STBD	25°	484	-	51	49
PORT	25°	484	+	36	64
PORT	25°	484	-	58	42
STBD	-25°	484	+	60	40
STBD	-25°	484	-	36	64
PORT	-25°	484	+	51	49
PORT	-25°	484	-	64	36

*LOAD DIRECTION

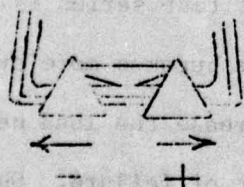

TABLE 2

E-24

III. STATIC TESTING

B. Results

3. Dual 50 hp Thru-Tilt (continued)

the point of failure is greater than 775 ft-lbs, and the information gained from the single 50 hp combined with the load-sharing data would indicate that the load necessary to fail the dual cable system is in excess of 1000 ft-lbs.

Subsequent to obtaining the dual 50 hp data, it was determined analytically that the maximum bending moment on the ram occurs at 17° for the single 50 hp under a given steering load. The steering angle at which the dual 50 hp data was recorded was 25°; however, the analysis showed that the difference in the bending moment between 17° and 25° was less than 3.5 percent. Since in a dual system the ram in tension receives a greater share of the load as the steering angle increases, the critical angle for the dual 50 hp installation would in all probability be closer to the 25° steering angle.

4. Single V4 Thru-Tilt

The V4 thru-tilt steering system geometry is different than the 50 hp in that the tilt tube centerline is displaced away from the attachment point on the steering arm. Appendix C illustrates the differences in loading that this causes. The cable force loading varies substantially as the ram moves from full extension to full retraction. Because of the increased drag link force component normal to the ram,

III. STATIC TESTING

B. Results

4. Single V4 Thru-Tilt (continued)

the bending moment on the ram is increased. These effects can be seen in the data listed in Tables 3 and 4.

As Table 4 shows, the ram begins to deform plastically when loaded with 400 ft-lbs and exceeds the failure deflection of .38 inch when loaded at 500 ft-lbs. In order for this to occur, the engine must be at a 25° angle and the loading must be such that it places the cable in compression. The critical angle was derived from the analysis in Appendix C and verified with the static test data. The criteria that the load must place the cable in compression and not in tension is due to the system geometry, which is sketched in Figure 7. As shown, the force along the drag link can be resolved into two components at the pinned connection with the block. The force F_1 with moment arm d creates a couple at the end of the ram that forms part of the bending moment. Whenever this force acts in the $-x$ direction, the bending will occur in the $-y$ direction, decreasing d . If d passes through zero and is deflected to the other side of the centerline of the ram, the bending moment created by F_1 will oppose the bending moment created by F_2 . Figure 8 illustrates this with a plot of the load versus the actual total (elastic and plastic) deflection of the end of the ram.

STEERING ASSEMBLY

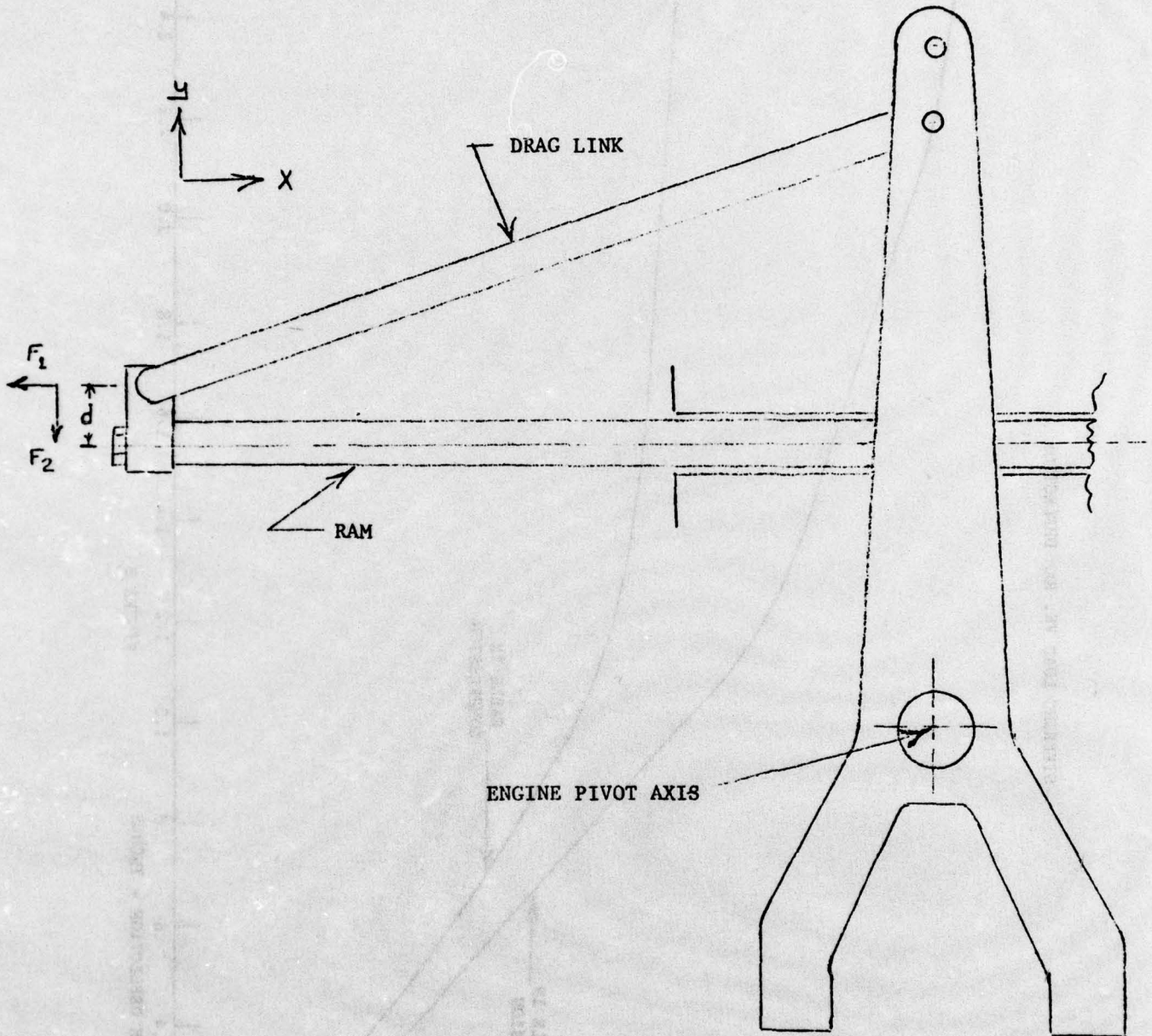

FIGURE 7

E-27

STEERING LOAD VS. RAM DEFLECTION

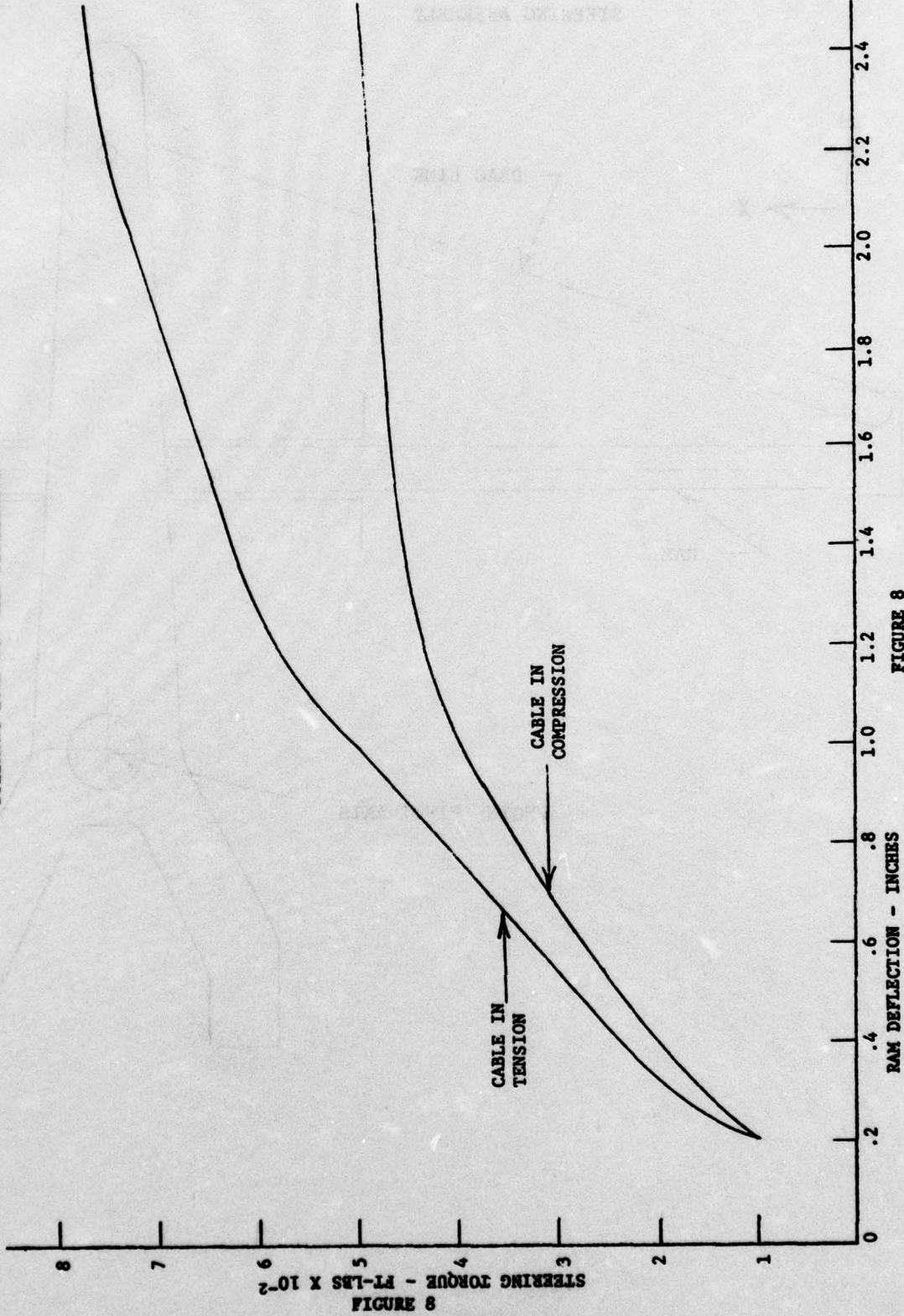

FIGURE 8

CABLE EXTENSION/COMPRESSION

<u>ANGLE</u>	<u>LOAD FT-LBS</u>	<u>EXTENSION INCHES</u>	<u>COMPRESSION INCHES</u>
-25°	460	.5	.6
0°	460	.4	.2
25°	500	.2	.2

TABLE 3

RAM BENDING

<u>LOAD FT-LBS</u>	<u>ANGLE</u>	<u>DEFLECTION</u>	
		<u>LOADED</u>	<u>PERMANENT</u>
460	- 25°	.19	.06
460	0°	.56	.25
400	25°	.75	.12
500	27°	1.75	.62

TABLE 4

III. STATIC TESTING

B. Results (continued)

5. Dual V-4 thru-tilt

The dual installation dual cable with tie-bar system is again statically indeterminate. In the case of a dual V-4 installation, however, the load is not shared as evenly as in the dual 50 hp system. Table 5 lists the load distributions for various angles and loads. There are 5 apparent factors that affect the load distribution:

- a. Cable in tension or compression - in all cases, the cable in tension carries the larger share of the load.
- b. Ram extended or retracted - as noted previously, when the ram is retracted, a given engine torque will create a higher load on the cable than when the ram is extended. This causes an extended ram to carry a larger proportion of the load.
- c. Cable length - the two-foot difference in cable length can be seen by comparing two values with reversed geometry. The 18-foot cable carries a greater load than the 20-foot cable under similar circumstances. There apparently is a difference in elasticity due to the difference in length.
- d. Amount of loading - as the level of loading increases, the cable loads tend toward equalization.

III. STATIC TESTING

B. Results

5. Dual V4 Thru-Tilt (continued)

- e. Engine angle - the geometry of the thru-tilt steering system is such that a given cable movement causes a greater change in steering angle when the ram is retracted than when the ram is extended. In a dual engine dual cable installation, the engines are locked together with a tie-bar so that a steering angle change is the same for both engines. When the engines are turned away from the straight-ahead position, this causes the cable-tie-bar system to be placed in tension. With a properly installed steering system, the dual cable installation can assume as much as 150 pounds tensile force in the tie-bar when turned to a maximum steering angle. With this tension preload, the cable in tension will assume an additional proportion of the steering load.

Table 5 shows that in one case, a cable assumed 92% of a 500 ft-lb load. The cable was in tension, the ram was extended, the cable was the shorter of the two, and the engines were turned at a 24° angle. In this case, the load was sufficient to cause .06 inch of permanent deflection. The system failed when the same ram assumed a .38-inch permanent offset due to a total load of 700 ft-lbs.

DUAL V4 STEERING
LOAD DISTRIBUTION

ENGINE LOADED	ENGINE ANGLE	LOAD FT-LBS	LOAD DIRECTION*	% OF TOTAL LOAD	
				18' CABLE	20' CABLE
STBD	0°	500	+	72	28
STBD	0°	500	-	44	56
PORT	0°	500	+	69	31
PORT	0°	500	-	44	56
STBD	24°	500	+	92	8
STBD	24°	500	-	26	74
PORT	24°	500	+	91	9
PORT	24°	500	-	24	76
STBD	-26°	500	+	77	23
STBD	-26°	500	-	19	81
PORT	-26°	500	+	74	26
PORT	-26°	500	-	16	84
PORT	-26°	550	-	18	82
PORT	-26°	600	-	19	81
PORT	-26°	650	-	21	79
PORT	-26°	700	-	22	78
STBD	28°	700	+	22	78

*LOAD DIRECTION

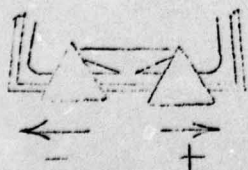

TABLE 5

III. STATIC TESTING

B. Results

5. Dual V4 Thru-Tilt (continued)

Since the cable loads in a dual cable system become more disparate when the system is placed in tension, an attempt was made to determine if one cable could be made to carry the entire load. By placing 130 pounds of tension on the system in the straight-ahead position, the cable in tension was forced into carrying essentially 100 per cent of the load. It should be noted, however, that the system was installed in a manner contrary to the installation instructions and it required a concerted effort to place that amount of tension on the system.

Due to the number of factors involved in determining the load on a single ram in a dual engine installation, as an additional test the engines were locked at a realistic steering angle of 15° and loaded in the direction that they would be during actual operation. Under these circumstances, which were dynamically feasible, the load necessary to fail the system was in excess of 1,200 ft-lbs steering torque.

6. Dual Engine Single Cable

Dual engine installations were not tested using only one cable although requested by the task order and specification sheet. Owner's manuals supplied with the engines and installation instructions, supplied with the steering systems include safety warnings which state that dual installations must utilize a twin cable system. In addition, it was

III. STATIC TESTING

B. Results

6. Dual Engine Single Cable (continued)

determined that the ram was the critical member of the thru-tilt steering system and it will fail at a certain level of loading independent of whether the load is supplied by one engine or by two engines connected with a tie-bar.

7. Static Vs. Simulated Impact Loads

In order to relate the static and dynamic data produced in this project, an attempt was made to reproduce the wave shape of the peak loads that were measured dynamically by impacting the lever arms used to load the steering systems statically. A V4 single installation was used for this simulated impact testing. Figures 9 and 10 show the results at the critical angle in both tension and compression. There was virtually no difference between the simulated impact loading required to permanently deflect and fail the ram and the level of loading that would do this statically. The time duration of the simulated impact was generally 2-4 times longer than the duration of the measured dynamic loads. Therefore, it would be conservative, however not unrealistic, to assume that the level of loading which will cause failure is similar for static and dynamic loading as recorded during actual testing.

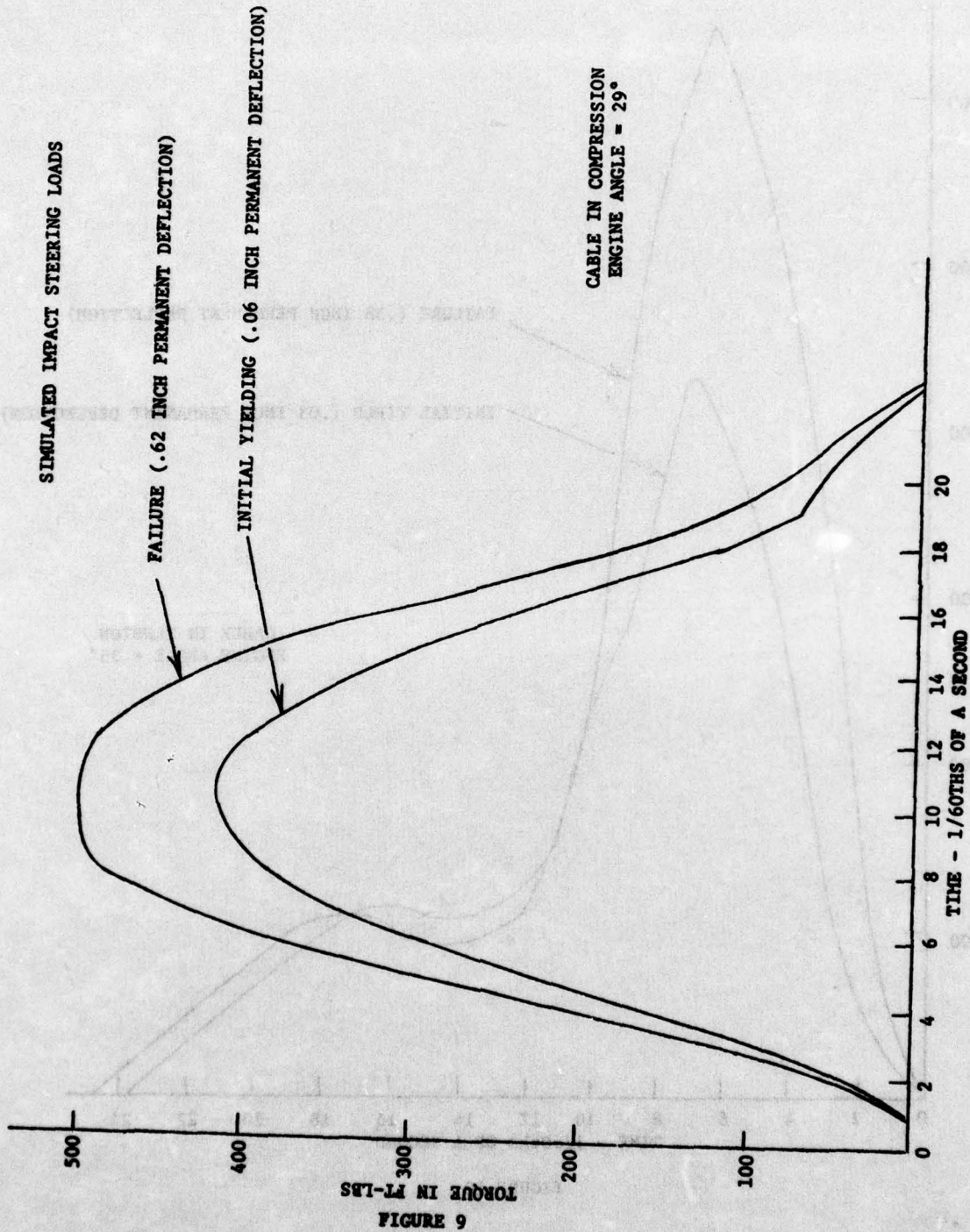

FIGURE 9

FIGURE 9

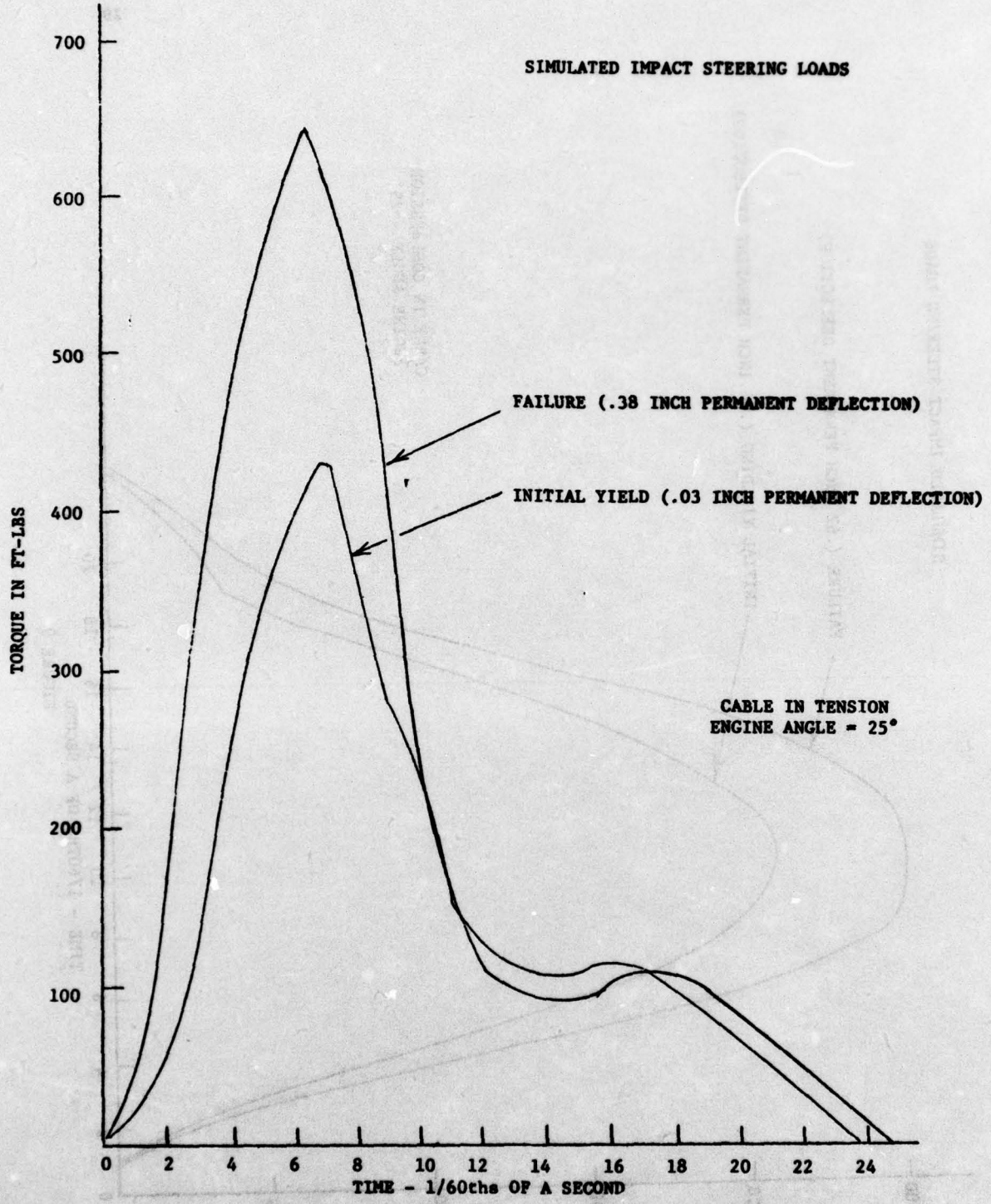

FIGURE 10

III. STATIC TESTING (continued)

C. Discussion

The transom-mounted steering system is attached to both the engine and the transom with ball joints. For this reason, the load on the steering ram will only be axial. It is capable of withstanding relatively high loads before it buckles under a compressive load.

In the thru-tilt steering system, the drag link places a bending load on the ram. The ram is therefore the most critical member in the steering system. During the static testing, the engines were turned to a certain angle and loaded so as to place the cable in compression. This was the most critical geometry of the thru-tilt system, and the minimum failure points were recorded in these positions. In actual dynamic loading, however, this configuration would be virtually impossible to obtain. Whenever the engine is turned so as to extend the ram, the load on the side of the gearcase will be on the side that will place the steering cable in tension. As noted in the static test results, this factor increases the load necessary to cause permanent deflection of enough magnitude to fail the system.

The same directional limitation applies to the dynamic loading of the dual thru-tilt steering system. If the engines are turned so as to extend one of the rams, the load will be in the direction that will place that ram in tension. Also, the peak loads obtained during the dynamic testing of dual outboards occurred at relatively low engine angles. The total load on a dual cable system is more evenly distributed at low engine angles than at the extremes.

IV. SUMMARY

During the dynamic test phase, the test boats were subjected to a variety of maneuvers intended to place maximum loads on the push-pull steering systems. In addition, the trim geometry of the dual V4 outboards was intentionally mis-adjusted. The peak loads, measured at the engine pivot point, were as follows:

Dual 135 outboards	600 ft-lbs at 10° steering angle
Dual 165 inboard/outboards	360 ft-lbs at 0° steering angle
Single 225 inboard/outboard	285 ft-lbs at 22° steering angle

The static test phase involved applying static loads to both transom-mounted and thru-tilt steering systems. The transom-mounted steering system became inoperable after a load of 890 ft-lbs was applied at the engine pivot point. The ram is the most critical member of the thru-tilt steering system and, for a given torque, will deflect to a greater extent when the cable is in compression than when it is in tension. The angle is also critical in that the maximum bending moment on the ram occurs at a 17° steering angle for the 50 hp and at a 25° steering angle for the V4 geometry. Under these conditions, the 50 hp and V4 rams become inoperable when loaded with 620 ft-lbs and 500 ft-lbs, respectively.

The dual engine, dual cable systems with the tie-bar pose a mathematically statically indeterminate problem. The amount of total load that a single cable in a dual cable system can carry is 66% for the 50 hp system. A single cable in a dual V4 system can carry as much as 92% if that ram is extended and loaded in tension. At lower angles, the load is more evenly distributed. Critical system configurations were defined in the static testing, along with the level of loading that would cause failure under those specific

IV. SUMMARY (continued)

conditions. The peak dynamic loads cannot be compared directly with the minimum failure loads of the static tests, since under boating conditions the maximum loads do not occur at the most critical geometry. Engine angle and direction of loading are critical to determining the point of failure of the system.

and linear. The peak dynamic load occurs at approximately 1000 Hz with the
 maximum strain rate of the order of 1000 in./in./sec. after about 1000 cycles
 the maximum load is not over 10% of the static strength. The strain rate
 and direction of loading are related to the direction of the force applied
 to the system.

APPENDIX A

DYNAMIC TEST DATA

DYNAMIC TEST DATA

Figures A-1 through A-14 are copies of Visicorder traces taken from the dynamic data. They are intended to show the variety of maneuvers and types of loading that occurred.

Figure A-15 is a calibration curve for the 135 hp outboard engine steering arm load cell. In a dual engine dual cable arrangement, the force applied by the drag link and that applied by the tie-bar do not coincide. This means that a given torque counteracted only by the tie-bar causes a different bending moment at the location of the bending bridge than the same torque counteracted only by the drag link. The calibration curves for the torque supported by the drag link only and by the tie-bar only are shown in Figure A-15 as lines A and C, respectively. Since the static testing showed that the strain indications were generally very close to the median line B, that curve was used to reduce the dynamic data. The maximum error introduced by using this line would be ± 10 per cent and would occur only if the total load were supported by a single cable.

The calibration curve for the stern drive steering bracket is shown in Figure A-16. The tie-bar axial load calibration curve is shown in Figure A-17.

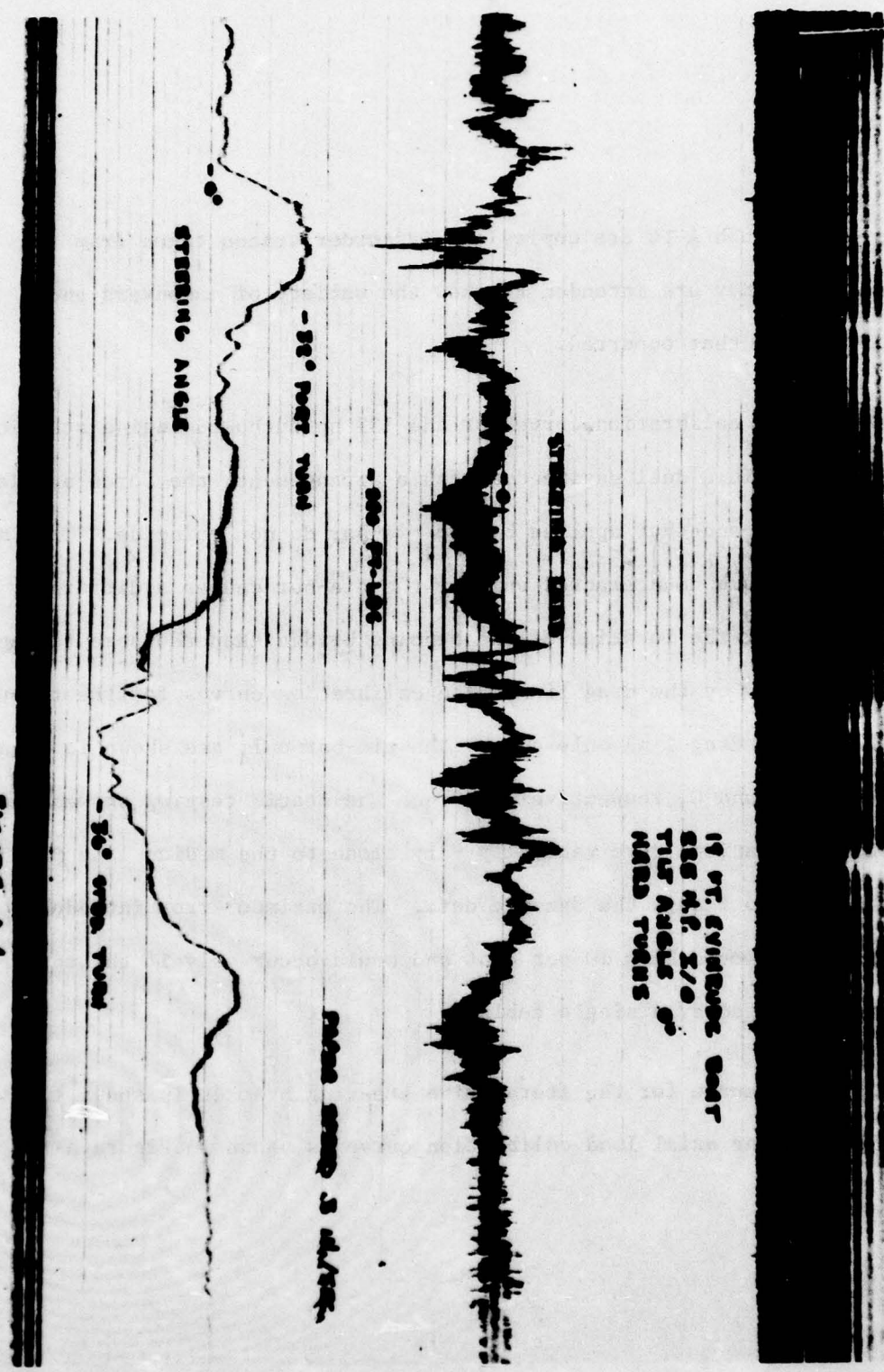

STEERING ANGLE

- 30° PORT TURN

- 000 PR-100

STEERING RATE

19 PT. EVINRUDE BOAT
 SER. N.P. 210
 TURN ANGLE 90°
 HARD TURNS

- 30° STARBOARD TURN

0000 0000 3 44/00

Figure A-1

19 FT. EVINRUDE BOAT
225 H.P. I/O
TILT ANGLE 0°
FISH TAILING

225 H.P. I/O

STEERING TORQUE

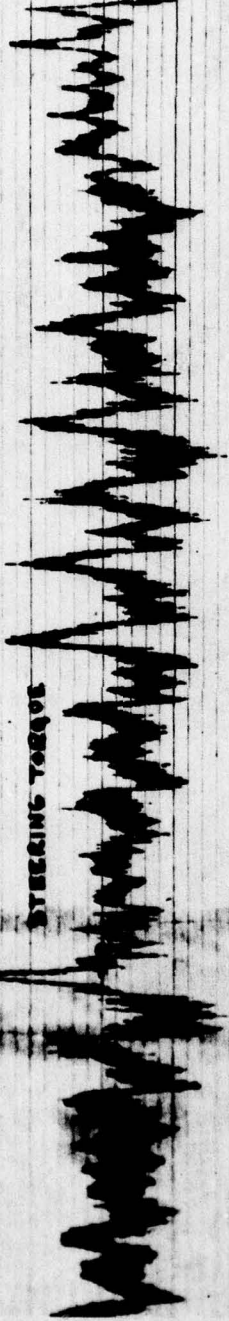

STEERING ANGLE

-10° P/P



PAPER SPEED .3 IN./SEC

FIGURE A-3

AD-A035 574

COAST GUARD RESEARCH AND DEVELOPMENT CENTER GROTON CONN F/G 13/10
INVESTIGATION OF RECREATIONAL BOAT STEERING AND CONTROL SYSTEMS--ETC(U)
APR 76 J R TAYLOR

UNCLASSIFIED

CGR/DC-8/76

USCG-D-119-76

NL

2 OF 2
AD
A035574

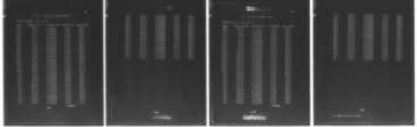
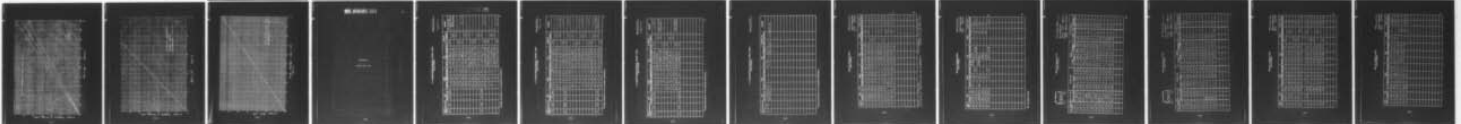
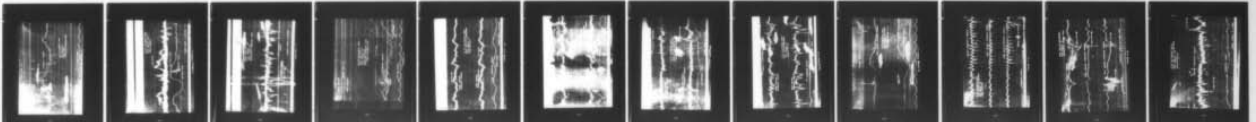

END

DATE
FILMED
3-77

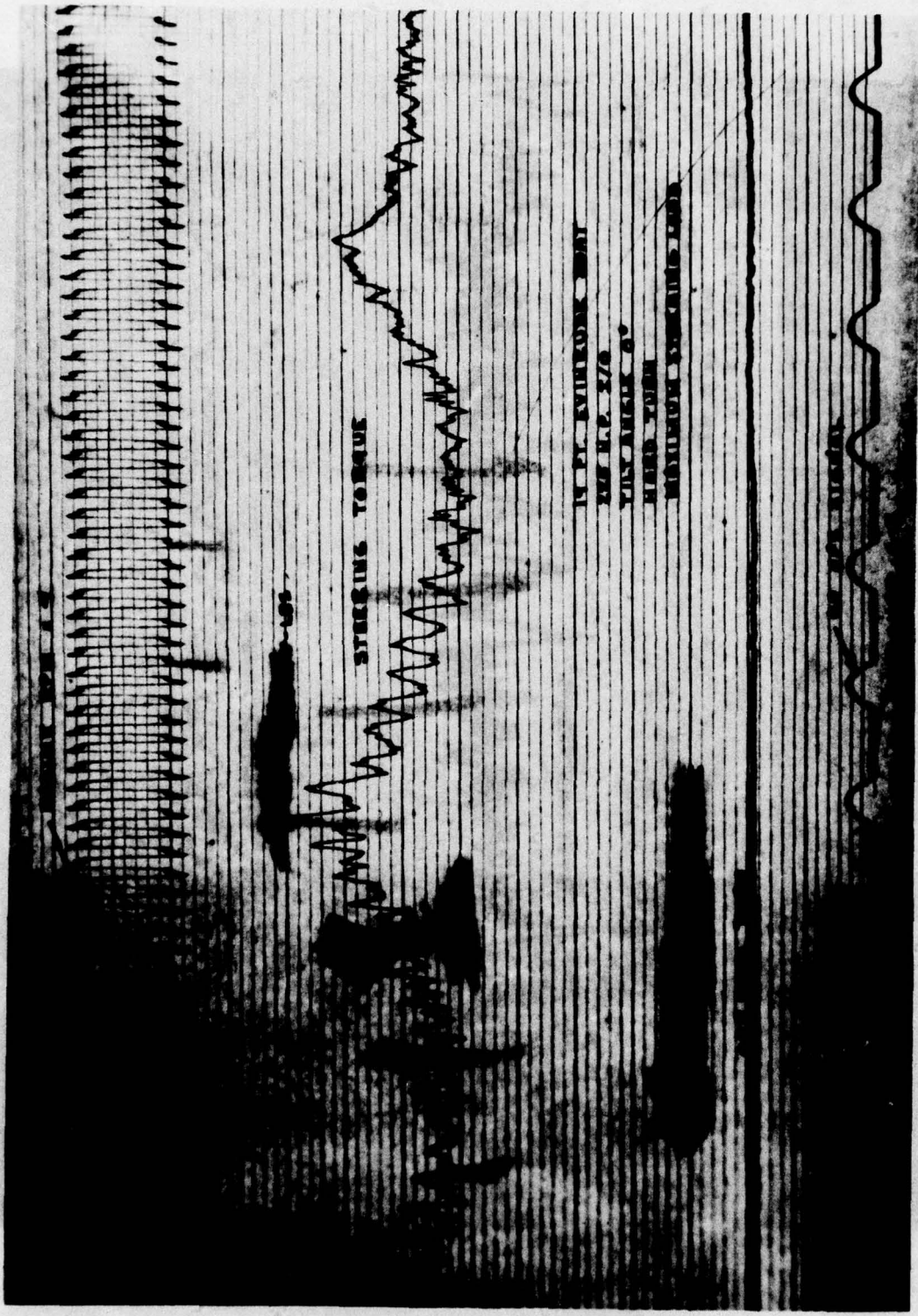

14 FT. WALKWAY BRAT
DUAL 155 HP. 170'S
TILT ANGLE 23°
RATED TURBS

- 265 FT-LBS



PAPER 3100 3 11/71

FIGURE A-4

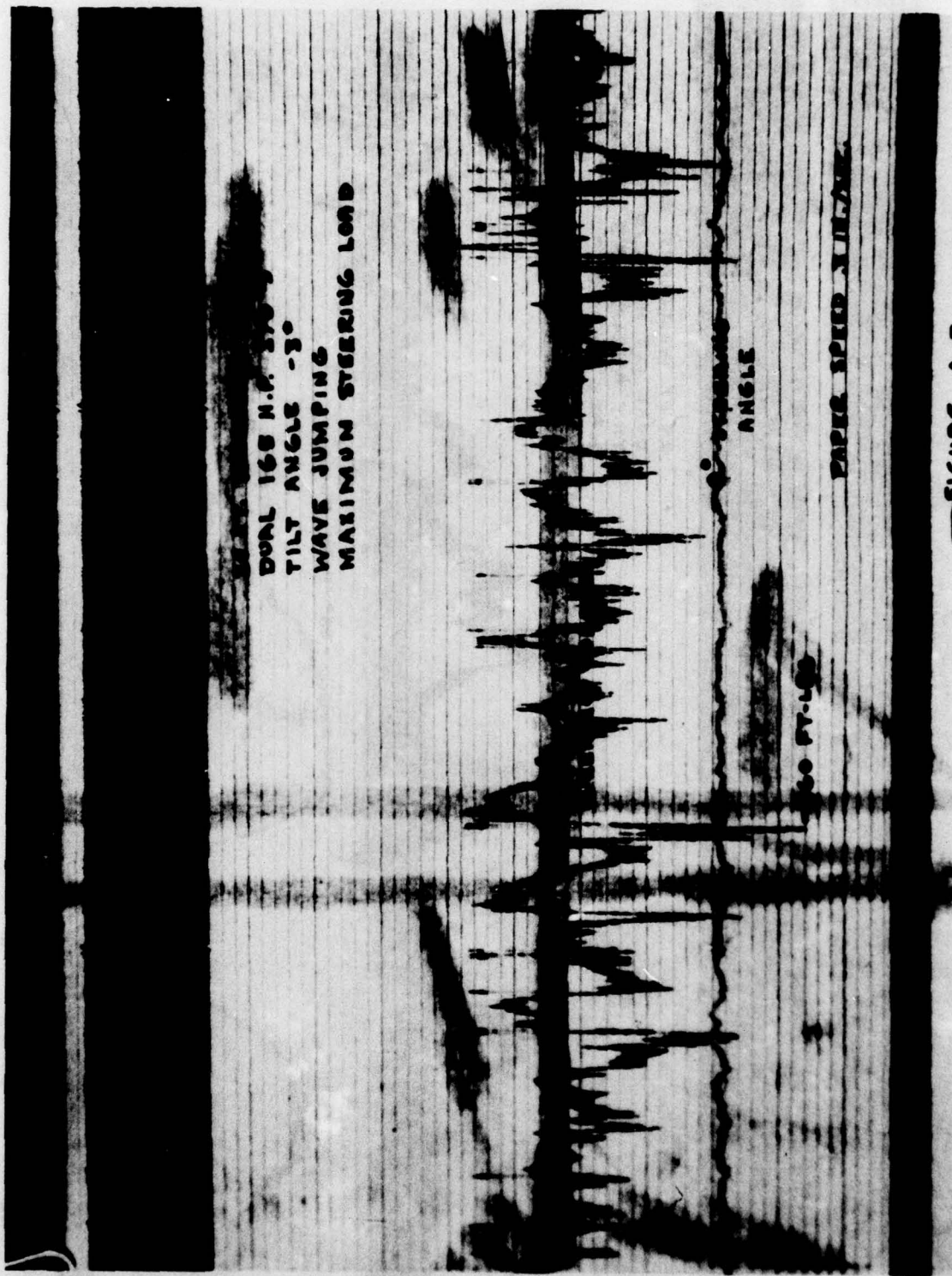
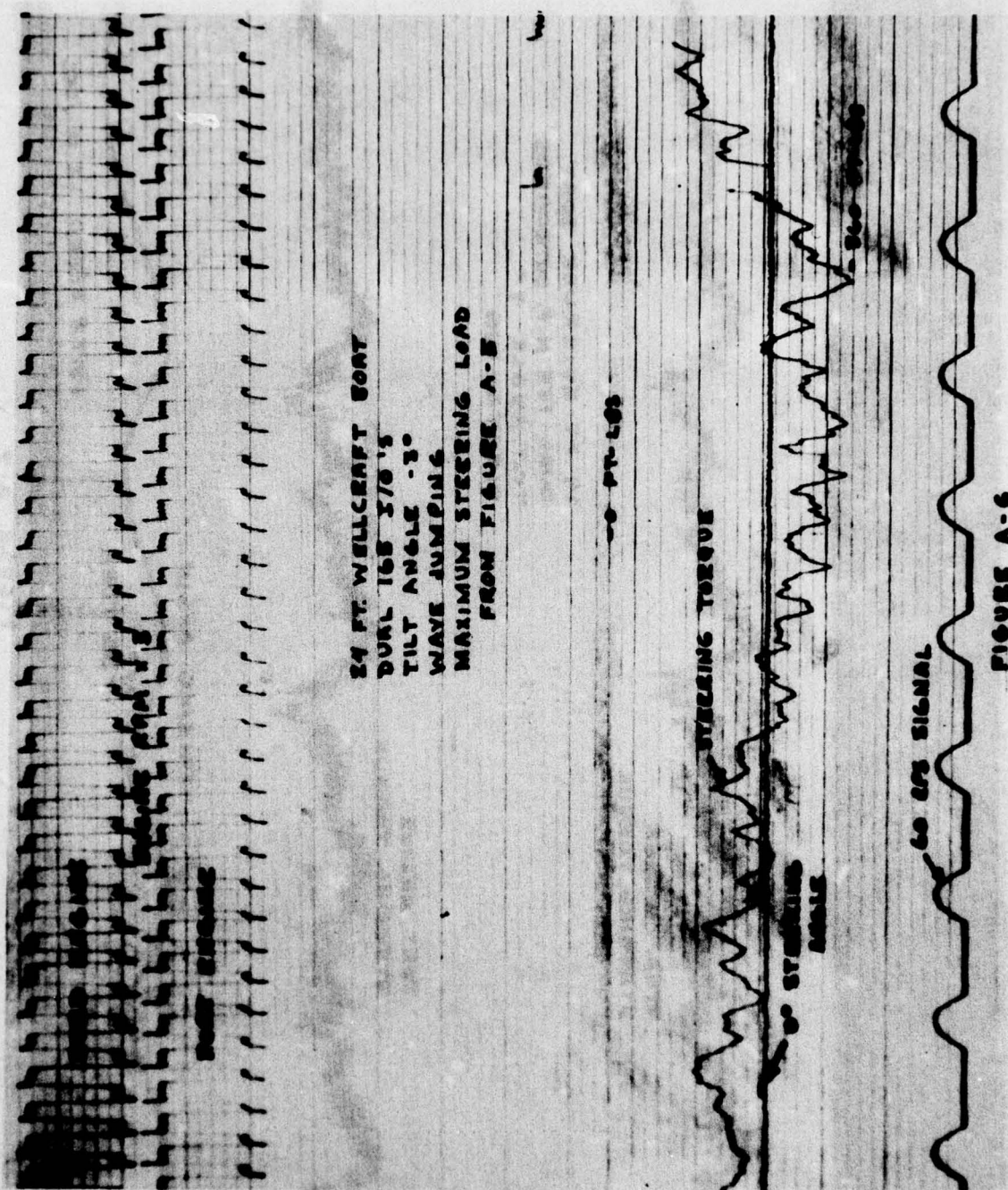

FIGURE A-6



24 FT. WELLCRAFT BOAT
 DURL 168 3/8'S
 TILT ANGLE -3°
 WAVE JUMPING
 MAXIMUM STEERING LEAD
 FROM FIGURE A-5

100 FT-LBS

STEERING TORQUE

60 CPS SIGNAL

FIGURE A-6

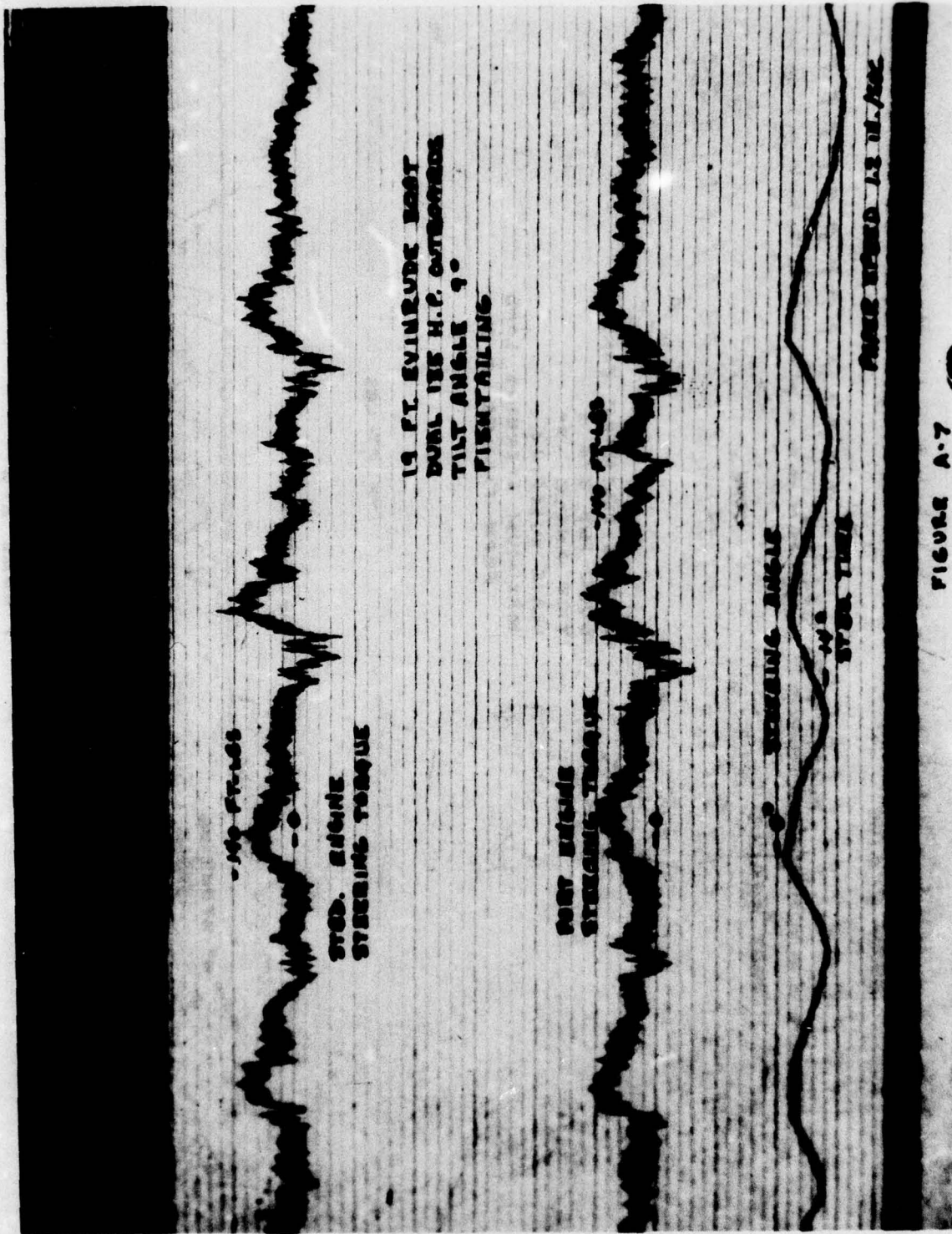
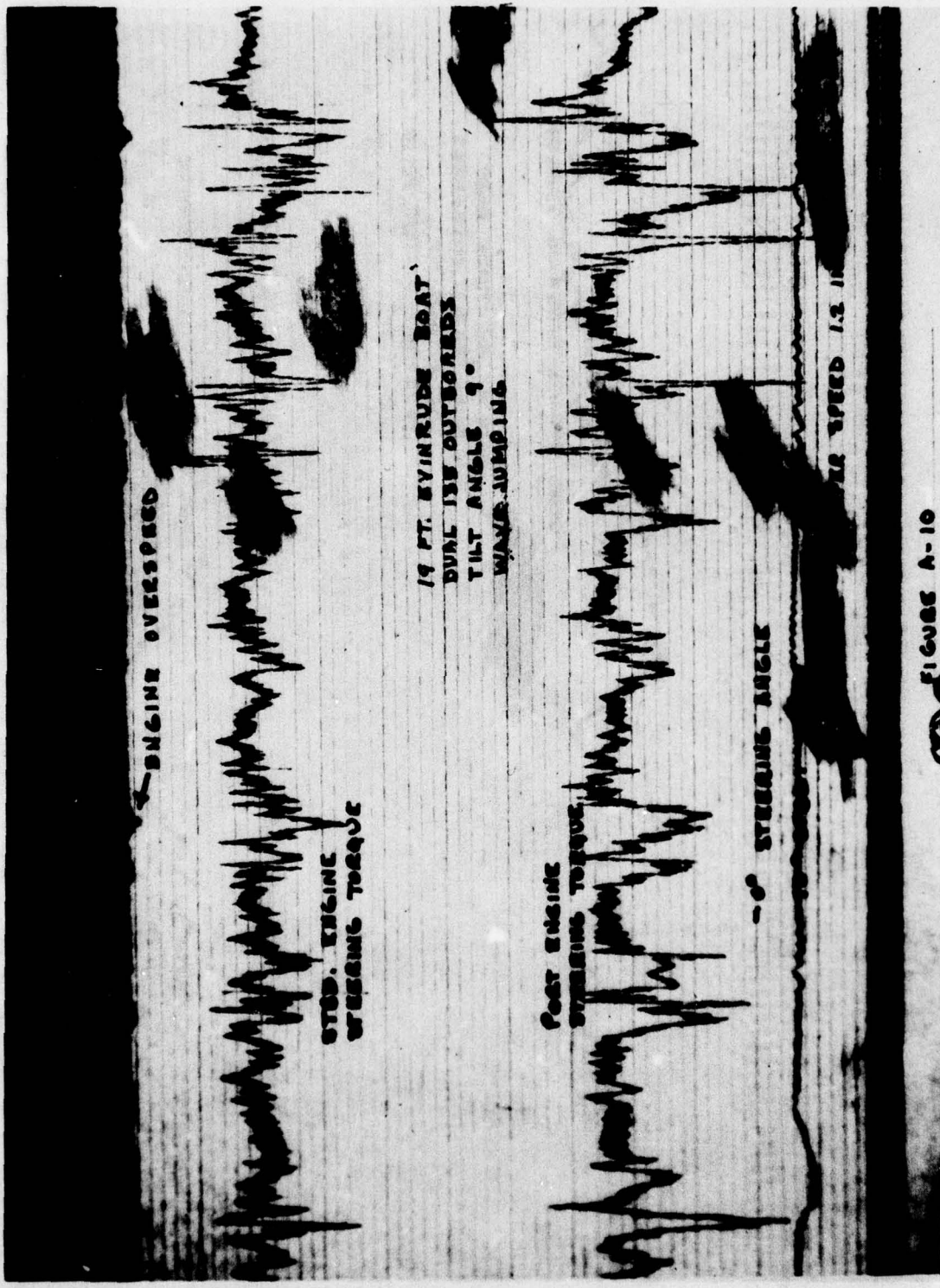

FIGURE A-7







19 FT. EYINRUDE BOAT
 DUAL ICE OUTFRIGS
 TILT ANGLE 9°
 WAVE JUMPING

ICE SPEED 1.3 IN

FIGURE A-10

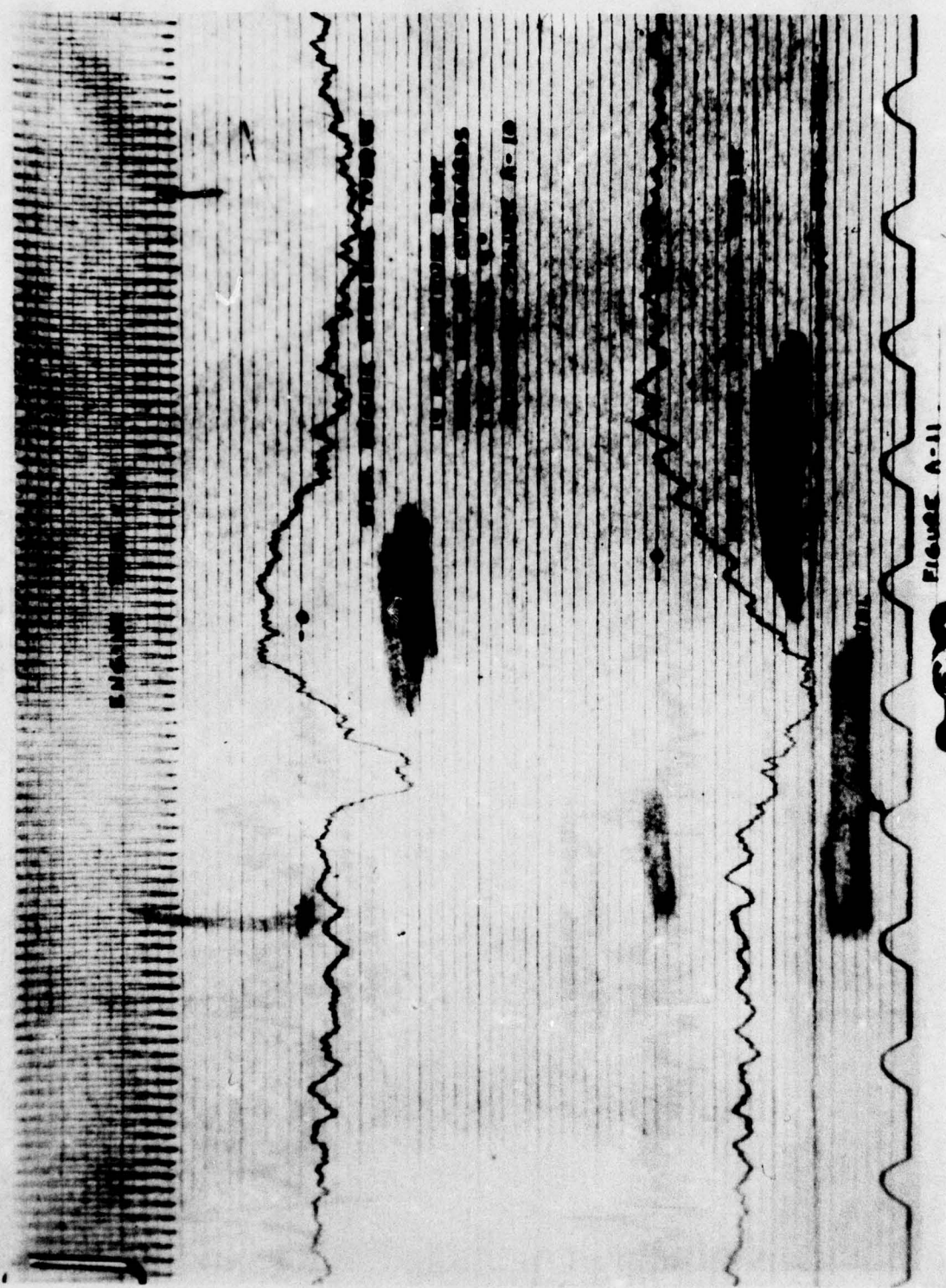

FIGURE A-11

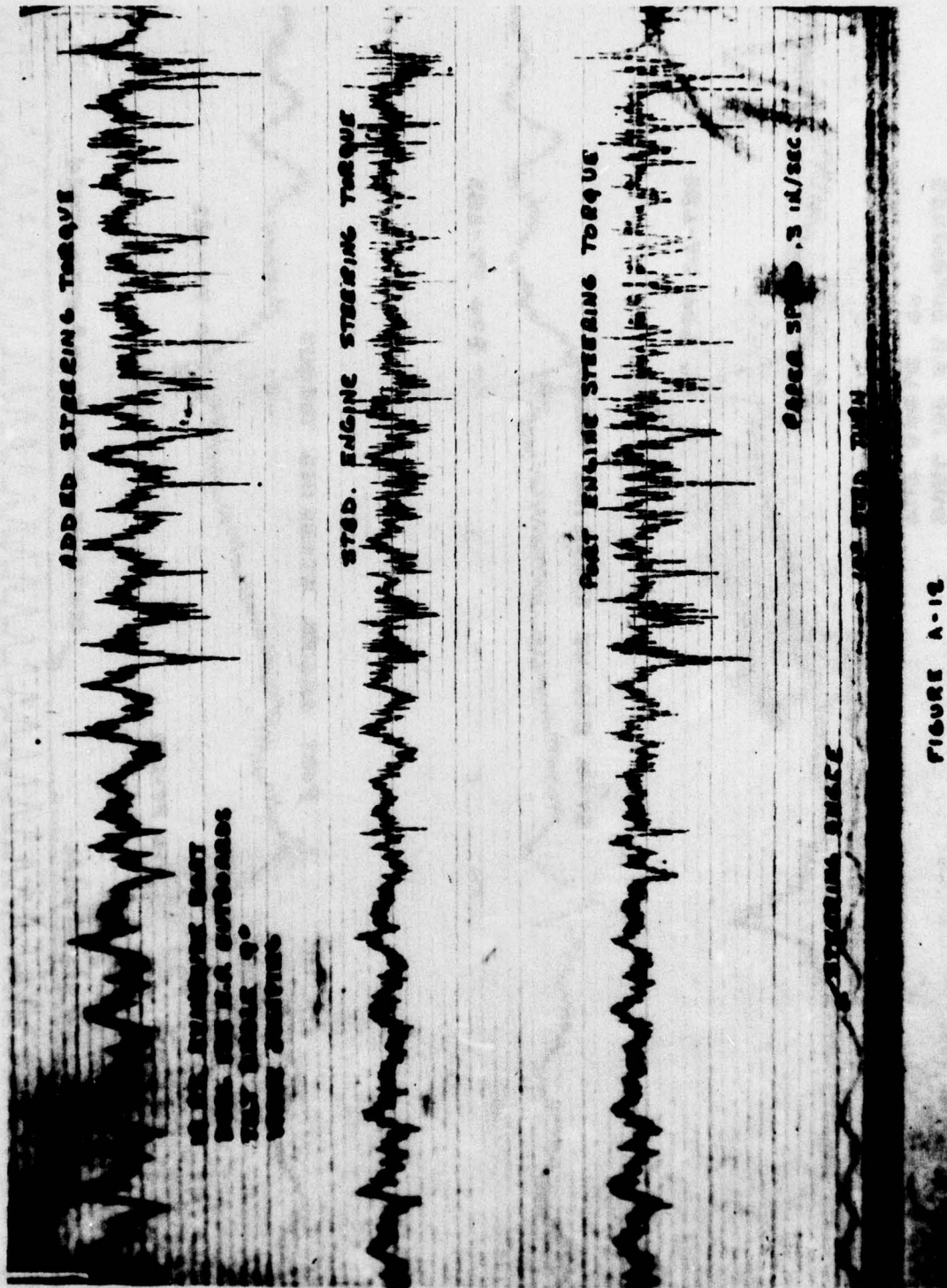

FIGURE A-12

DUAL 175 H.P. OUTBOARDS
TILT ANGLE 9°
REFERENCE POINTS A-D

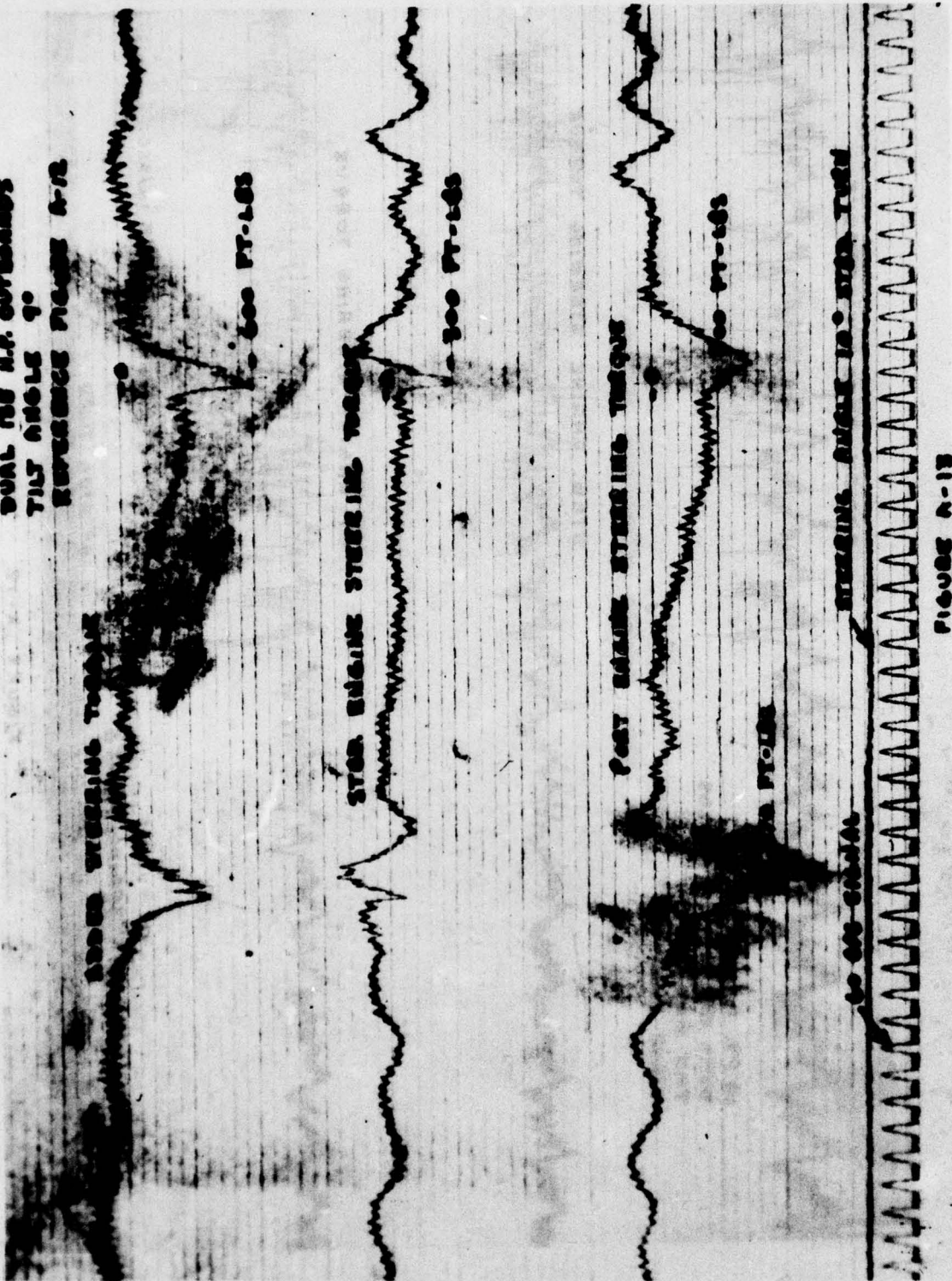
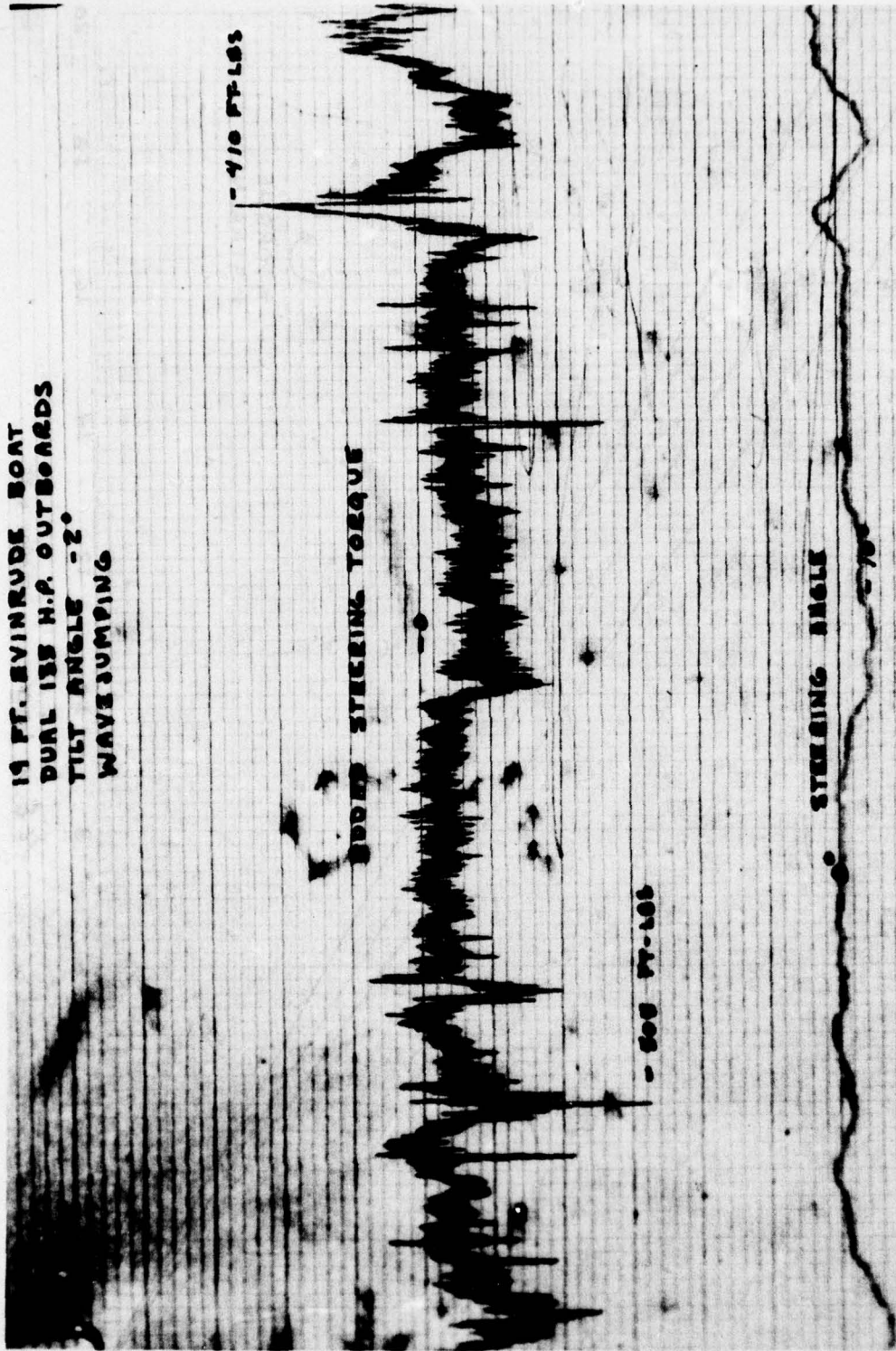

FIGURE A-13

19 FT. EVINRUDE BOAT
DUAL 135 H.P. OUTBOARDS
TILT ANGLE -2°
WAVEJUMPING



- 4/10 FT-LS

TORQUE

STEERING ANGLE

PAPER SPEED .3 IN./SEC.

- 600 FT-LS

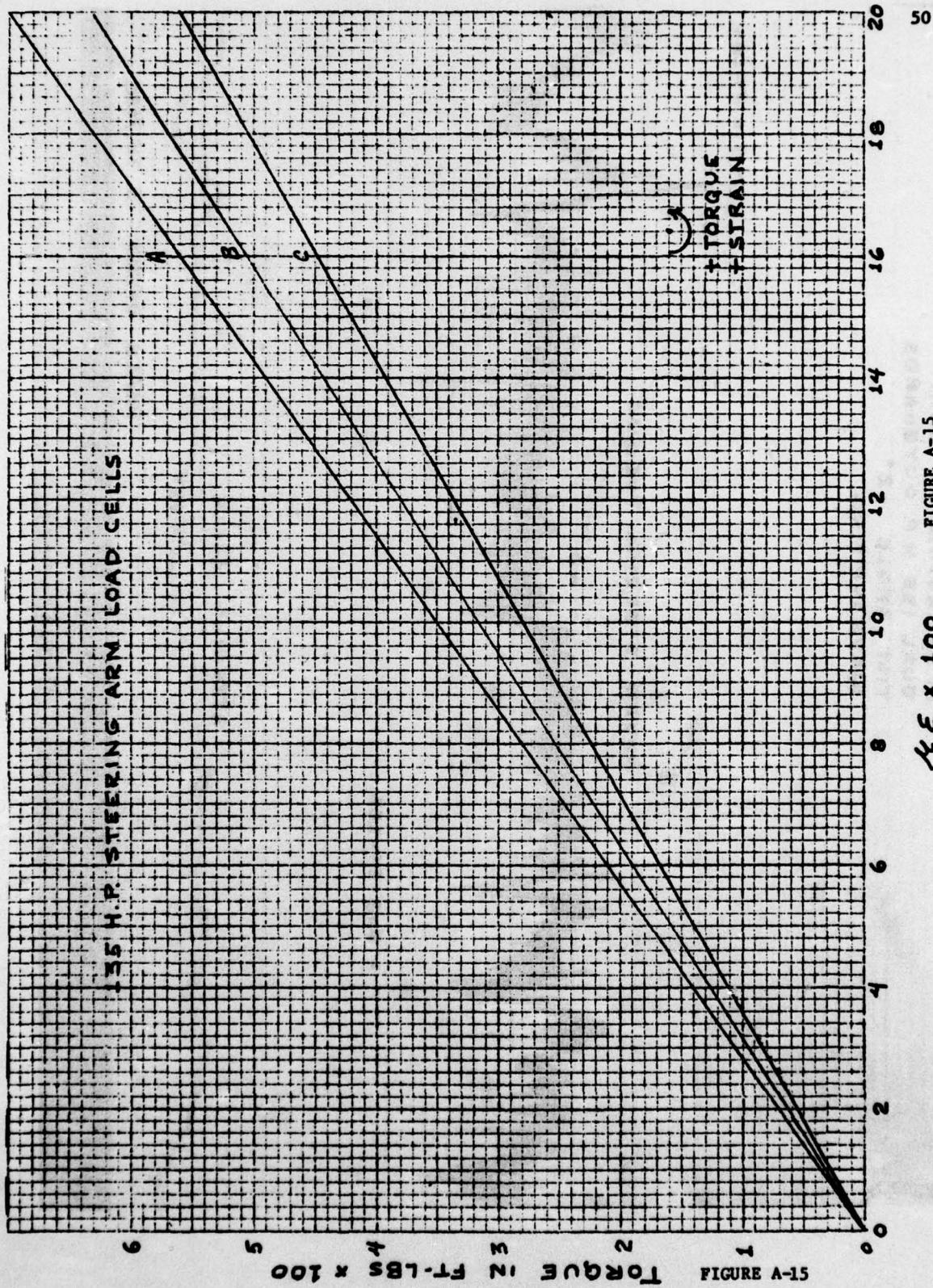

50

FIGURE A-15

KE x 100

FIGURE A-15

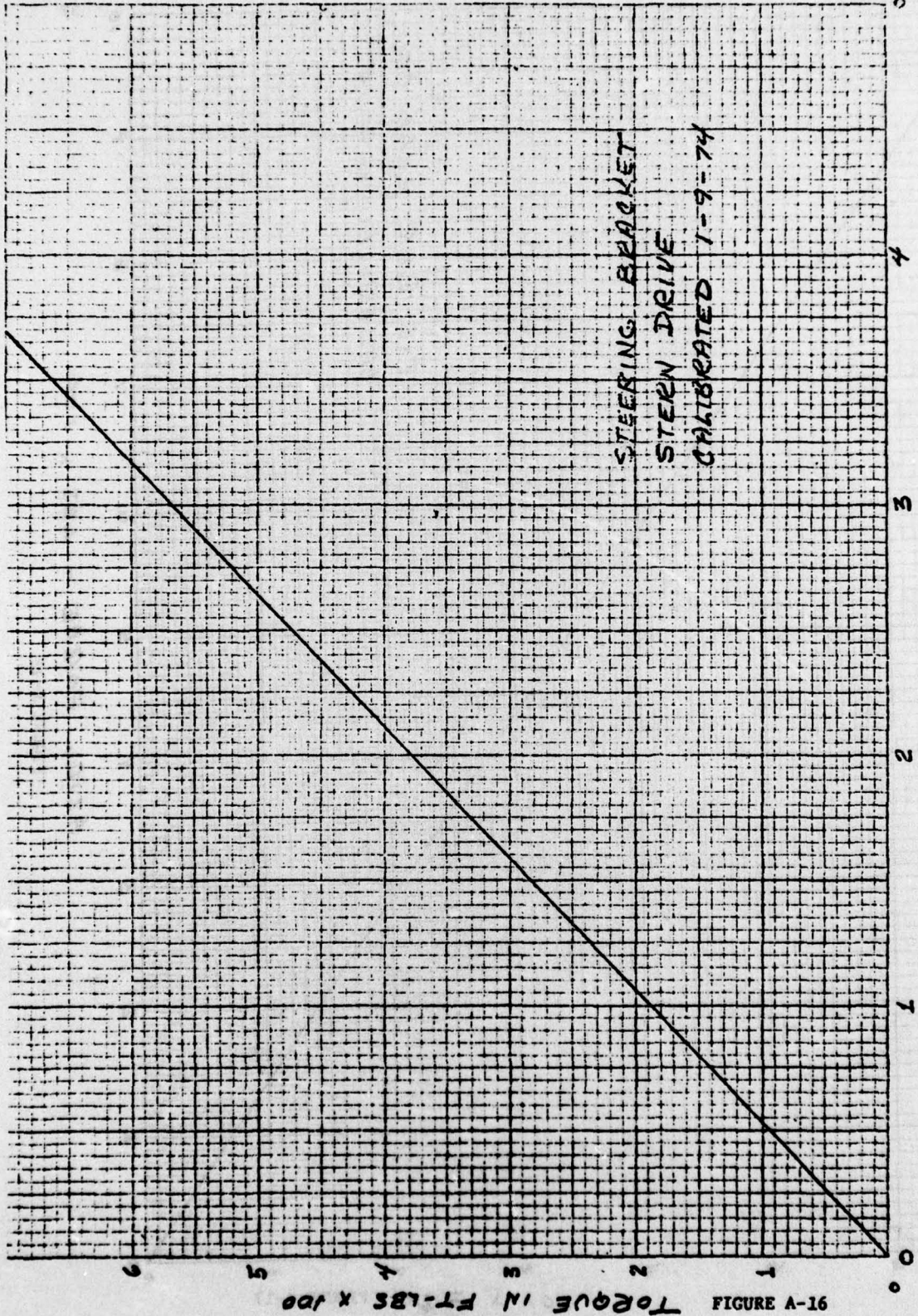
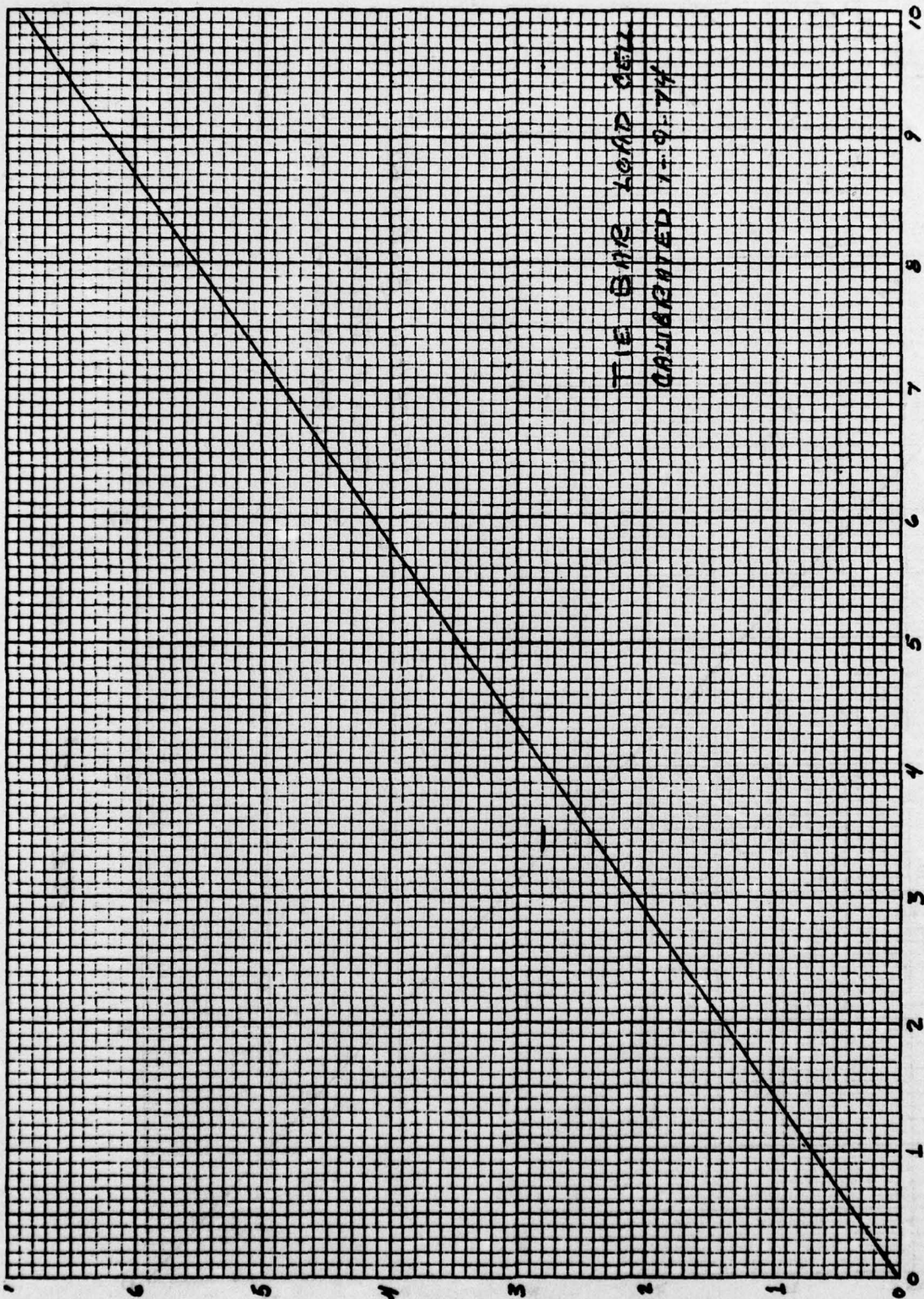

FIGURE A-16
TORQUE IN FT-LBS x 100

FIGURE A-16

AE x 10³



THE SHIP LOAD CELL
CALIBRATED 1-9-74

AXIAL FORCE - LBS x 100

FIGURE A-17

KE x 100

This data was generated by the instrument described in the following report:

WATER	TEMPERATURE	DEPTH	TIME	DATE	LOCATION	INSTRUMENT	REMARKS
1	18.0	1	0	020	000	020	020
0	14.0	0	0	032	000	020	020
12	16.0	12	0	040	000	020	020
12	18.0	12	0	050	000	020	020
22	20.2	22	0	055	000	020	020
50	20.0	50	0	065	000	020	020
50	20.0	50	0	075	000	020	020
50	20.0	50	0	085	000	020	020
50	20.0	50	0	095	000	020	020
50	20.0	50	0	105	000	020	020
50	20.0	50	0	115	000	020	020
50	20.0	50	0	125	000	020	020
50	20.0	50	0	135	000	020	020
50	20.0	50	0	145	000	020	020
50	20.0	50	0	155	000	020	020
50	20.0	50	0	165	000	020	020
50	20.0	50	0	175	000	020	020
50	20.0	50	0	185	000	020	020
50	20.0	50	0	195	000	020	020
50	20.0	50	0	205	000	020	020
50	20.0	50	0	215	000	020	020
50	20.0	50	0	225	000	020	020
50	20.0	50	0	235	000	020	020
50	20.0	50	0	245	000	020	020
50	20.0	50	0	255	000	020	020
50	20.0	50	0	265	000	020	020
50	20.0	50	0	275	000	020	020
50	20.0	50	0	285	000	020	020
50	20.0	50	0	295	000	020	020
50	20.0	50	0	305	000	020	020
50	20.0	50	0	315	000	020	020
50	20.0	50	0	325	000	020	020
50	20.0	50	0	335	000	020	020
50	20.0	50	0	345	000	020	020
50	20.0	50	0	355	000	020	020
50	20.0	50	0	365	000	020	020
50	20.0	50	0	375	000	020	020
50	20.0	50	0	385	000	020	020
50	20.0	50	0	395	000	020	020
50	20.0	50	0	405	000	020	020
50	20.0	50	0	415	000	020	020
50	20.0	50	0	425	000	020	020
50	20.0	50	0	435	000	020	020
50	20.0	50	0	445	000	020	020
50	20.0	50	0	455	000	020	020
50	20.0	50	0	465	000	020	020
50	20.0	50	0	475	000	020	020
50	20.0	50	0	485	000	020	020
50	20.0	50	0	495	000	020	020
50	20.0	50	0	505	000	020	020
50	20.0	50	0	515	000	020	020
50	20.0	50	0	525	000	020	020
50	20.0	50	0	535	000	020	020
50	20.0	50	0	545	000	020	020
50	20.0	50	0	555	000	020	020
50	20.0	50	0	565	000	020	020
50	20.0	50	0	575	000	020	020
50	20.0	50	0	585	000	020	020
50	20.0	50	0	595	000	020	020
50	20.0	50	0	605	000	020	020
50	20.0	50	0	615	000	020	020
50	20.0	50	0	625	000	020	020
50	20.0	50	0	635	000	020	020
50	20.0	50	0	645	000	020	020
50	20.0	50	0	655	000	020	020
50	20.0	50	0	665	000	020	020
50	20.0	50	0	675	000	020	020
50	20.0	50	0	685	000	020	020
50	20.0	50	0	695	000	020	020
50	20.0	50	0	705	000	020	020
50	20.0	50	0	715	000	020	020
50	20.0	50	0	725	000	020	020
50	20.0	50	0	735	000	020	020
50	20.0	50	0	745	000	020	020
50	20.0	50	0	755	000	020	020
50	20.0	50	0	765	000	020	020
50	20.0	50	0	775	000	020	020
50	20.0	50	0	785	000	020	020
50	20.0	50	0	795	000	020	020
50	20.0	50	0	805	000	020	020
50	20.0	50	0	815	000	020	020
50	20.0	50	0	825	000	020	020
50	20.0	50	0	835	000	020	020
50	20.0	50	0	845	000	020	020
50	20.0	50	0	855	000	020	020
50	20.0	50	0	865	000	020	020
50	20.0	50	0	875	000	020	020
50	20.0	50	0	885	000	020	020
50	20.0	50	0	895	000	020	020
50	20.0	50	0	905	000	020	020
50	20.0	50	0	915	000	020	020
50	20.0	50	0	925	000	020	020
50	20.0	50	0	935	000	020	020
50	20.0	50	0	945	000	020	020
50	20.0	50	0	955	000	020	020
50	20.0	50	0	965	000	020	020
50	20.0	50	0	975	000	020	020
50	20.0	50	0	985	000	020	020
50	20.0	50	0	995	000	020	020

APPENDIX B
STATIC TEST DATA

NATIONAL BUREAU OF STANDARDS
 4-1 APPROXIMATE MASS ACCURACY ESTIMATED FROM
 WEIGHT MEASUREMENTS

F-4 TRANSONIC-MOUNTED MECHANICAL STEERING SYSTEM
 STATIC TESTING

DATE 2/14/74

SHEET #1

YELT ANGLE	ELEVATION	LOAD		ANGLE		RAH			CABLE		REMARKS*	
		FT-LBS	KG	INITIAL	LOADED	UNLOADED	INITIAL	LOADED	UNLOADED	EXT.		COMP.
2°	1ST	560	1780	0	3°	0	7.06	7.48	7.06	.12		KEY INDICATES - CABLE TENSION
				-1°	-3.5°	-1°	7.06	6.38	6.56		.68	+ RAM R. HORIZONTAL
				-15°	-18°	-15°	4.00	3.50	4.00		.50	+
				-16°	-13°	-16°	4.12	4.75	4.12	.63		-
				-26°	-23°	-25°	2.31	2.88	2.62	.67		- .31 EXT
				-26°	-29°	-26°	2.25	1.75	2.25		.50	+
				15°	10°	15°	8.62	8.12	8.62		.50	+
				16°	20°	16°	8.88	9.25	8.88	.37		-
				26°	30°	26°	10.32	10.88	10.32	.56		-
				24°	20°	24°	10.12	9.62	10.12		.50	+
2°	2ND	560	1780	24°	20°	24°	10.12	9.62	10.12		.50	+
				25°	30.5°	26°	10.32	10.88	10.38	.56		- .06 EXT
				16°	20°	16°	8.88	9.38	8.88	.50		-
				15°	11°	15°	8.75	8.19	8.69		.56	+
				0	-4°	0	6.38	5.88	6.38		.50	+
				1	5°	1°	6.50	7.00	6.56	.50		- .06 EXT

* Include description of any permanent deformation

V-4 TRANSOM-MOUNTED MECHANICAL STEERING SYSTEM
 STATIC TESTING

DATE 2/14/74

SHEET #2

TILT ANGLE	ELEVATION	LOAD		ANGLE		RAM			CABLE		REMARKS*	
		FT-LBS	μs	INITIAL	LOADED	UNLOADED	INITIAL	LOADED	UNLOADED	EXT.		COMP.
2°	2 ND	560	1780	15.5°	19°	15.5°	8.75	9.19	8.75	.44		-
				13.5	8°	13.5	8.50	8.00	8.50	.50		+
				25°	20°	25°	10.19	9.75	10.25	.44		+
				26°	31°	27°	10.38	11.00	10.50	.62		-
2°	3 RD	560	1780	27°	31°	27°	10.50	11.00	10.50	.50		-
				26°	20°	25°	10.31	9.75	10.25	.56		+
				15°	12°	15°	8.81	8.31	8.81	.50		+
				16°	21°	17°	9.00	9.44	9.00	.56		-
				0	5°	0	6.44	6.94	6.50	.50		-
				0	-4°	-1°	6.31	5.75	6.19	.56		+
				-16°	-20°	-16°	3.81	3.31	3.81	.50		+
				-15°	-10°	-14°	3.94	4.44	4.00	.50		-
				-24°	-21°	-24°	2.38	2.81	2.38	.43		-
				-25°	-30°	-26°	2.25	1.75	2.19	.50		+
2°	4 TH	560	1780	-26°	-31°	-27°	2.19	1.75	2.25	.56		+
				-26°	-20°	-25°	2.38	2.88	2.38	.50		-

* Include description of any permanent deformation

V-4 TRANSON-MOUNTED MECHANICAL STEERING SYSTEM
 STATIC TESTING

DATE 2/14/74

SHEET #3

TILT ANGLE	ELEVATION	LOAD		ANGLE			RAM			CABLE		REMARKS*
		FT-LBS	KG	INITIAL	LOADED	UNLOADED	INITIAL	LOADED	UNLOADED	EXT.	COMP.	
2°	4TH	560	1780	-14°	-11°	-14°	4.00	4.44	3.94	.14		- .06 AMP 2
				-15°	-20°	-16°	3.88	3.25	3.81		.63	+
				0	-4°	0°	6.38	5.88	6.38		50	+ RAM 5° FROM HORIZONTAL
				1°	5°	2°	6.50	7.06	6.56	.56		-
				16°	20°	16°	8.88	9.38	8.88	.50		-
				15°	10°	14°	8.75	8.19	8.75		.56	+
				24°	19°	23°	10.19	9.62	10.12		.56	+
				25°	30°	26°	10.25	10.88	10.31	.53		- RAM ANGLE 4° FROM HOR.
2	4TH	630	2000	26°	31°	26°	10.31	10.88	10.31	.56		

* Include description of any permanent deformation

THRU-TILT STEERING SYSTEM
STATIC TESTING

DATE 3-1-74

SINGLE INSTALLATION

V4 50 HP

TILT ANGLE	LOAD ***		ANGLE			RAM			CABLE		RAM DEFL.	
	FT-LBS	MC	INITIAL	LOADED	UNLOADED	INITIAL	LOADED	UNLOADED	TENSION	COMPRESSION	LOADED	UNLOADED
-5°	388	1920	-26°	-31°	-26°	2.56	2.00	2.38		.56	0	0
12°	388	1920	-26°	-32°	-26°	2.62	2.12	2.56		.50	0	0
-5°	388	1860	-24°	-19°	-23°	2.75	3.25	2.62	.50		.12	0
12°	388	1860	-24°	-20°	-24°	2.81	3.19	2.31	.38		.12	0
-5°	388	2090	0°	5°	0°	6.00	6.50	6.00		.50	.12	0
-5°	388	1820	-1°	-6°	-2°	5.38	5.88	5.75		.50	.25	.12
-5°	388	2130	26°	32°	25°	9.75	10.12	9.62	.37		.75	.12
-5°	388	2100	24°	19°	24°	9.62	9.25	9.50		.37	.50	0
-5°	434	2620	24°	19°	24°	9.50	9.25	9.50		.25	.75	.12
-5°	542	2860	24°	13°	24°	9.50	9.19	9.62		.31	1.00	.19

* DRAG ON STEERING
** STEERING IMPAIRED BUT NOT INOPERABLE
*** STEERING ARM DEFLECTION WAS 0.06 IN FOR ALL LOADS

THRU-TILT STEERING SYSTEM
STATIC TESTING

DATE 3-7-74

SINGLE INSTALLATION

V4 50 HP

TILT ANGLE	LOAD		ANGLE			RAK			CABLE		RAM DEFL.	
	FT-LBS	KG	INITIAL	LOADED	UNLOADED	INITIAL	LOADED	UNLOADED	TENSION	COMPRESSION	LOADED	UNLOAD
-5°	232	1250	20°	17°		8.88	8.75			.13		.25
-5°	310	1670		15°	20°		8.62	8.88		.13		.38
-5°	388	2200	20°	15°		8.88	8.81			.07		.50
-5°	466	2490		14°			8.56			.25		.75
-5°	543	2980		12°			8.50			.06		1.0
-5°	620	3400		11°	17°		8.62	8.88				1.5
												.62 *

*

* INOPERABLE

LOAD DIRECTION



THRU-TILT STEERING SYSTEM
STATIC TESTING

DATE 3-2-74

DUAL INSTALLATION

ENGINE: V-4 50 HP

STEERING CABLE: DUAL SINGLE

TILT ANGLE	ENGINE ANGLE	LOAD (FT-LBS)		TIE-BAR LOAD		CABLES				RAM DEFLECTION					
		PORT	STBD	DIR	AXIAL	TORQUE	%	TORQUE	%	STARBOARD	TORQUE	%	PORT	STARBOARD	
												LOADED	UNLOADED	LOADED	UNLOADED
-5°	0°	0	484	+	-320	250	52	250	48	234	25	0	.25	0	0
-5°	0°	484	0	+	250	195	40	289	40	195	.12	0	.12	0	0
-5°	0°	484	0	-	-335	262	54	222	54	262	.25	0	.25	0	0
-5°	0°	0	484	-	215	168	34	168	66	316	.12	0	.25	0	0
-5°	25°	0	484	+	-230	163	34	163	66	321	0	0	.75	0	0
-5°	25°	484	0	+	435	308	64	176	64	308	0	0	.50	0	0
-5°	25°	0	484	-	335	237	49	237	51	247	0	0	.38	0	0
-5°	25°	484	0	-	-290	305	42	279	42	305	.06	0	.50	0	0
-5°	25°	484	0	-	-230	163	34	321	34	163	.12	0	0	0	0
-5°	25°	0	484	-	435	308	64	308	36	176	.50	0	0	0	0
-5°	25°	0	484	+	-275	175	40	195	60	237	.38	0	.12	0	0
-5°	25°	484	0	+	335	237	49	247	49	237	.38	0	.12	0	0

LOAD DIRECTION



THRU-TILT STEERING SYSTEM
STATIC TESTING

DATE 3-4-74

DUAL INSTALLATION
ENGINE: V-4 50 HP
STEERING: DUAL SINGLE
CABLE

TILT ANGLE	ENGINE ANGLE	LOAD (FT-LBS)		TIE-BAR LOAD		CABLES				R.M. DEFLECTION			
		PORT	STBD	AXIAL	TORQUE	%	TORQUE	%	TORQUE	PORT LOADED	PORT UNLOADED	STARBOARD LOADED	STARBOARD UNLOADED
-5°	-23°	0	434	-260	187	39	187	61	297	0	0	0	0
-5°	-23°	0	581	-320	230	40	230	60	351	0	0	0	0
-5°	-23°	0	775	-490	353	45	353	55	422	0	0	0	0
-5°	-27°	0	434	-260	181	37	181	63	303	0	0	0	0
-5°	-27°	0	581	-330	230	40	230	60	351	0	0	0	0
-5°	-27°	0	675	-370	272	40	272	60	406	0	0	0	0
-5°	-27°	0	775	-490	341	44	341	56	424	0	0	0	0
-5°	-27°	484	0	-230	160	33	324	33	160	75	75	0	0
-5°	-27°	531	0	-300	209	36	372	36	209	75	75	0	0
-5°	-27°	678	0	-380	265	39	413	39	265	75	75	0	0
-5°	-27°	775	0	-495	302	39	472	39	302	75	75	0	0

THRU-TILT STEERING SYSTEM
STATIC TESTING

DATE 2-26-74

SINGLE INSTALLATION

V4 50 HP

TILT ANGLE	LOAD		ANGLE		RAM			CABLE		RAM DEFL.		
	FT-LBS	μC	INITIAL	LOADED	UNLOADED	INITIAL	LOADED	UNLOADED	TENSION	COMPRESSION	LOADED	UNLOADED
-2°	460	1430	-24°	-19°	-24°	1.75	2.19	1.75	.44		.12	
-2°	460	1430	-26°	-31°	-26°	1.62	1.06	1.62		.56	.12	
2°	460	1430	-26°	-31°	-26°	1.62	1.12	1.62		.50	.06	
2°	460	1430	-25°	-30°	-24°	1.75	2.19	1.75	.44		.06	
13°	460	1430	-24°	-20°	-24°	1.75	2.25	1.75	.50		.12	
13°	460	1430	-26°	-32°	-26°	1.62	1.12	1.62		.50	.19	.06
-2°	8460	1430	0°	-4°	0°	5.00	4.75	5.00		.25	.38	0
-2°	"	1430	1°	5°	1°	5.00	5.38	5.06	.38		.50	.12
2°	"	1430	1°	5°	1°	5.06	5.33	5.06	.32		.44	0
2°	"	1430	0°	-4°	0°	5.00	4.75	4.94		.25	.50	.19
13°	"	1430	0°	-4°	0°	4.94	4.75	4.94		.19	.38	0
13°	"	1430	1°	5°	2°	5.06	5.38	5.12	.32		.56	.25

LOAD DIRECTION

THRU-TILT STEERING SYSTEM
STATIC TESTING

DATE 2-27-74

DUAL INSTALLATION

ENGINE: V-4 50 HPSTEERING CABLE: DUAL SINGLE

TILT ANGLE	ENGINE ANGLE	LOAD (FT-LBS)		TIE-BAR LOAD		CABLES				RAM DEFLECTION			
		PORT	STHD	AXIAL	TORQUE	%	TORQUE	%	TORQUE	%	PORT LOADED	PORT UNLOADED	STARBOARD LOADED
-2°	1°	0	500	-180	141	23	141	72	359	.12	0	.25	0
-2°	1°	0	500	-360	281	56	281	44	219	.12	0	.06	0
-2°	-4°	0	500	-200	156	31	344	31	156	.25	0	.12	0
-2°	2°	0	500	-360	281	56	219	56	281	.12	0	.25	0
-2°	28°	0	500	-60	41	3	41	92	459	0	0	.62	.06
-2°	27°	0	500	650	453	11	47	91	453	.06	0	.62	.06
-2°	20°	0	500	-160	117	24	332	24	117	0	0	.50	.06
-2°	21°	0	500	-510	372	74	372	26	127	0	0	.50	0
-2°	-23°	0	500	-160	115	23	115	77	385	.38	0	0	0
-2°	-22°	0	500	510	367	74	130	74	369	.38	0	0	0
-2°	-30°	0	500	-115	78	16	422	16	78	.75	.06	0	0
-2°	-30°	0	500	595	403	81	403	19	97	.62	0	0	0
-2°	-30°	0	500	-145	98	18	452	18	98	.50	0	.25	0
-2°	-30°	0	600	-165	112	19	488	19	112	.75	0	.12	0
-2°	-31°	0	650	-200	134	21	516	21	134	.83	.06	.12	0

LOAD DIRECTION



THRU-TILT STEERING SYSTEM
STATIC TESTING

DATE **3-1-74**

DUAL INSTALLATION

ENGINE: V-4 50 HP

STEERING CABLE: DUAL SINGLE

NOTE: TIE BAR INSTALLED IN TENSION
130 LBS. AXIAL

TILT ANGLE	ENGINE ANGLE	LOAD (FT-LBS)		TIE-BAR LOAD		CABLES				RAY DEFLECTION					
		PORT	STBD	DIR	AXIAL	TORQUE	%	PORT % TORQUE	STARBOARD % TORQUE	LOADED	UNLOADED	LOADED	UNLOADED		
-2°	0°	0	400	+	15	12		-	-	100+	412	.12	0	.19	0
-2°	0°	0	400	-	465	363		91	363	9	37	.25	0	.12	0
-2°	0°	400	0	-	-30	23		94	377	6	23	.25	0	.12	0
-2°	0°	400	0	+	510	399		0	1	100	399	.12	0	.25	0
-2°	24°	160	160	+	290	207		-	-	100+	367	0		.50	
-2°	24°	200	200	+	335	239		-	-	100+	439	0		.50	
-2°	24°	240	240	+	350	250		-	-	100+	490	0	0	.62	.12
-2°	24°	300	300	+	420	300		0	0	100	600	0	0	1.12	.38

LOAD DIRECTION



THRU-TILT STEERING SYSTEM
STATIC TESTING

DATE: 4-11-74

DUAL INSTALLATION

ENGINE: V-4 50 HP

STEERING: DUAL SINGLE

TILT ANGLE	ENGINE ANGLE	LOAD (FT-LBS)		TIE-BAR LOAD			CABLES				RAM DEFLECTION				
		PORT	STBD	DIR	AXIAL	TORQUE	%	PORT TORQUE	%	STARBOARD TORQUE	%	PORT LOADED	PORT UNLOADED	STARBOARD LOADED	STARBOARD UNLOADED
-2°	15°	300	0	+	260	176	65	35	104	65	196	.12	.12	.12	.12
					290	219	63	37	131	63	219	.12	.12	.12	.12
					325	245	61	39	155	61	245	.12	.12	.12	.12
					355	268	60	40	182	60	268	.12	.12	.12	.12
					390	294	59	41	206	59	294	.12	.12	.12	.12
					420	317	58	42	233	58	317	.12	.12	.12	.12
					465	354	58	42	249	58	354	.12	.12	.12	.12
					495	374	57	43	276	57	374	.12	.12	.12	.12
					535	403	58	42	297	58	403	.12	.12	.12	.12
					595	449	60	40	301	60	449	.12	.12	.12	.12
					625	472	59	41	323	59	472	.12	.12	.12	.12
					655	495	58	42	355	58	495	.12	.12	.12	.12
					740	558	58	42	402	58	558	.12	.12	.12	.12
					770	581	58	42	419	58	581	.12	.12	.12	.12
					810	612	56	44	488	56	612	.12	.12	.12	.12

* ROLLED END OF STEEL RAM LOOSE - ALLOWED .12 IN. DEFLECTION

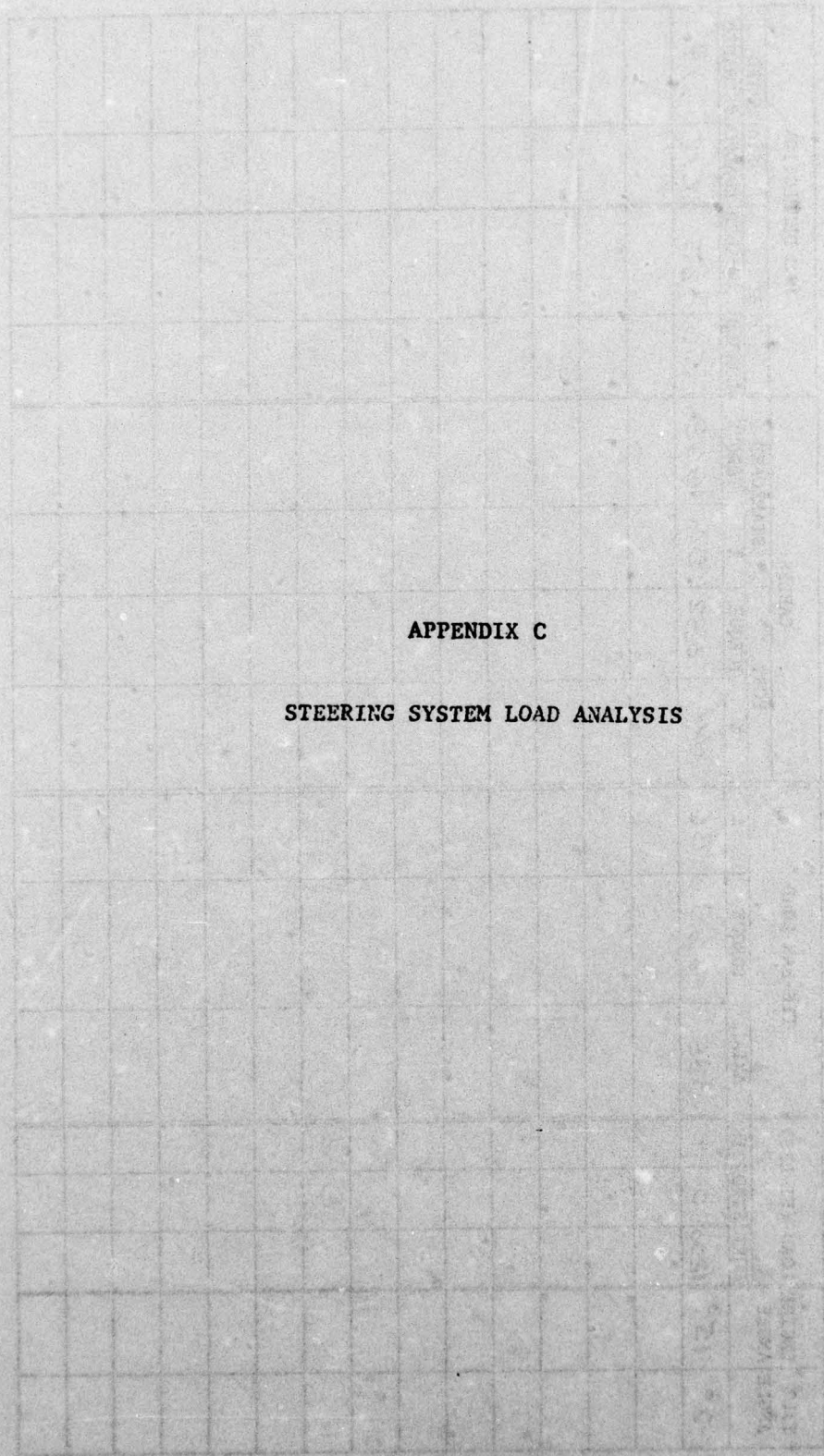

APPENDIX C

STEERING SYSTEM LOAD ANALYSIS

ANALYSIS OF THE LOADS PRODUCED
ON A THRU-TILT STEERING SYSTEM

A computer program was developed that would calculate the bending moment on the ram, the maximum stress due to this bending moment, the deflection of the end of the ram, and the force induced in the cable for any given engine steering torque. The program iterates in one degree increments through the entire range of engine travel.

The geometry of the system is shown in Figures 1 and 2. "O" is the pivot point of the engine. "O₁" is the point at which the drag link connects to the steering arm. "O₂" is a point on the ram at which it enters the tilt tube. This is the point that will have the maximum bending moment, M.

Following is the derivation of the equations used for the range of travel as shown in Figure 1, i.e. θ varies from 0° to 32°.

$$\begin{aligned} M &= M_1 + M_2 \\ M_1 &= F_1 x \\ F_1 &= F_D \cos \phi \\ \textcircled{1} M_1 &= x F_D \cos \phi \end{aligned} \qquad \begin{aligned} M_2 &= F_2 (d \cos \phi + a \sin \theta - y) \\ F_2 &= F_D \sin \phi \\ \textcircled{2} M_2 &= F_D \sin \phi (d \cos \phi + a \sin \theta - y) \end{aligned}$$

$$F_T = T \left(\frac{12}{a} \right)$$

$$\cos \rho = \frac{F_T}{F_D}$$

$$F_D = \frac{F_T}{\cos \rho}$$

$$\rho = 90 - \phi - (90 - \theta) = \theta - \phi$$

$$F_D = \frac{\frac{12T}{a}}{\cos(\theta - \phi)}$$

$$\text{From } \textcircled{1} M_1 = (x \cos \phi) \left(\frac{\frac{12T}{a}}{\cos(\theta - \phi)} \right)$$

$$\text{From } \textcircled{2} M_2 = \left(\frac{\frac{12T}{a}}{\cos(\theta - \phi)} \right) \sin \phi (d \cos \phi + a \sin \theta - y)$$

To determine $\phi = f(\theta)$

$$\sin \phi = \frac{a \cos \theta - x - z}{d}$$

$$\phi = \arcsin \left(\frac{a \cos \theta - x - z}{d} \right)$$

$$M_1 = \left[x \cos \left(\arcsin \left(\frac{a \cos \theta - x - z}{d} \right) \right) \right] \left[\frac{\frac{12T}{a}}{\cos \left(\theta - \arcsin \left(\frac{a \cos \theta - x - z}{d} \right) \right)} \right]$$

$$M_2 = \left[\frac{\frac{12T}{a}}{\cos \left(\theta - \arcsin \left(\frac{a \cos \theta - x - z}{d} \right) \right)} \right] \left(\frac{a \cos \theta - x - z}{d} \right) \\ \left[d \cos \left(\arcsin \left(\frac{a \cos \theta - x - z}{d} \right) \right) + a \sin \theta - y \right]$$

In Figure 2, θ varies from -32° to 0° . In this case, $\rho = \theta + \phi$ rather than $\theta - \phi$. However, since θ is negative:

$$\rho = -\theta - \phi \text{ and } -\rho = \theta + \phi$$

Since we are using the cosine of ρ , and the angle is $<90^\circ$, the $-\rho$ does not change the results. Also, the moment arm of F_2 is

$$d \cos \phi - a \sin \theta - y \text{ rather than } \\ d \cos \phi + a \sin \theta - y$$

Since θ is negative and less than 90° , the sign of $a \sin \theta$ will automatically be negative. Therefore, the same equations can be used for a negative θ .

The maximum stress is calculated from the bending moment using an equation of the form:

$$\delta = \frac{Mc}{I}$$

The deflection of the end of the ram is calculated by superimposing the deflections due to each of the moments M_1 and M_2 .

or:
$$\delta_1 = \frac{M_1 L^2}{2EI} \quad (L = \text{exposed length of the ram})$$

$$\delta_2 = \frac{F_2 L^3}{3EI}$$

and:
$$\delta = \delta_1 + \delta_2$$

The cable force is simply equal to F_1 .

The following assumptions apply to this program:

1. All motion is in the plane of rotation.
2. All stresses are within the elastic limit of the material.
3. Only small deflections occur.
4. There is no clearance between the ram and tilt-tube.

Due to these assumptions, the absolute values produced by the program are valid only under low loads; however, the program is valuable for determining relative values for the various parameters under higher loads as well.

The program must be run in FORTRAN on Cyphernetics. It will ask for the steering torque, which is the torque measured at the engine pivot. Attached is a program listing and a sample run for both the V-4 and 50 hp geometry.

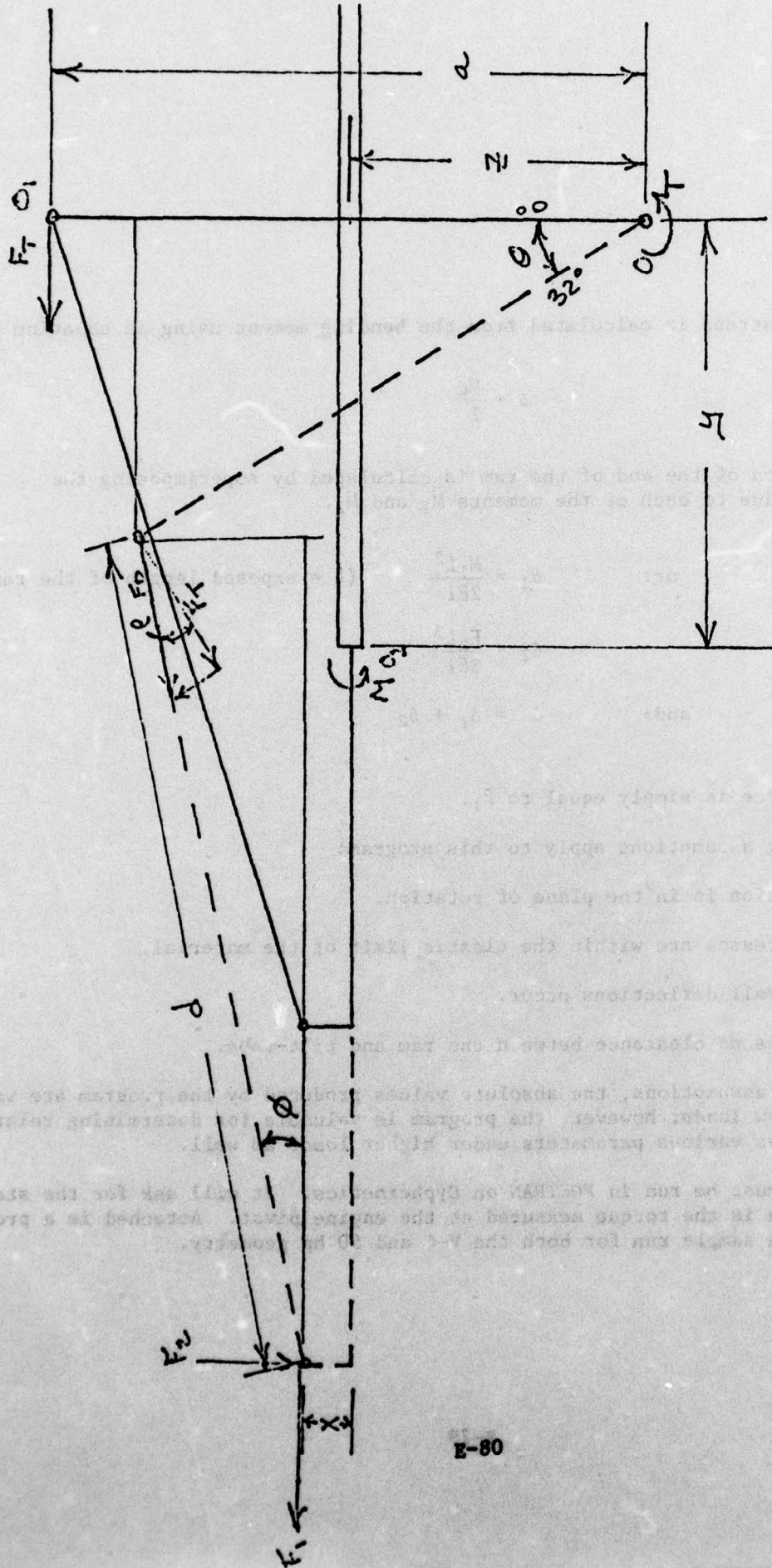

```

000000 1974 50 H.P. STEERING SYSTEM LOADS
000010 THIS PROGRAM CALCULATES THE STEERING LOADS ON THE THRU-TILT
000020 STEERING SYSTEM FOR A GIVEN STEERING TORQUE MEASURED AT THE
000030 ENGINE PIVOT POINT. -MVS
00090 REAL I,M1,M2,LL
00100 A=9.0
00110 Z=5.19
00120 X=.615
00130 D=11.15
00140 C=.310
00150 F=.2275
00160 E=30*10**6
00170 PI=3.141592
00180 Y=5.5
00200 THETA=-.5582
00220 I=(PI*(C**4-F**4))/4
00230 CC=1/(E*I)
00300 TYPE 10
00310 10 FORMAT(' ENTER STEERING TORQUE IN FT-LBS')
00320 20 ACCEPT 30,T
00330 30 FORMAT(1F)
00335 TYPE 15
00336 15 FORMAT('///18X,50 H.P. THRU-TILT STEERING LOADS')
00400 TYPE 40,T
00410 40 FORMAT('///,18H STEERING TORQUE =,F6.1,7H FT-LBS)
00420 TYPE 45
00430 45 FORMAT(' ANGLE BENDING MOMENT MAXIMUM STRESS
00431 ' DEFLECTION CABLE FORCE')
00440 TYPE 50
00450 50 FORMAT(3X,'DEG',9X,'FT-LBS',12X,'PSI',12X,'IN',10X,'LBS')
00500 60 AA=((A*CC*(THETA))-Z-X)/D
00510 BB=(12*T/A)/(CC*(THETA-ASIN(AA)))
00520 M1=(X*CC*(ASIN(AA)))*BB
00525 F1=CC*(ASIN(AA))*BB
00530 M2=BB*AA*(D*CC*(ASIN(AA))+A*SIN(THETA)-Y)
00540 BEND=(M1+M2)/12
00550 STRESS=(BEND*12*C)/I
00560 LL=D*CC*(ASIN(AA))+A*SIN(THETA)-Y
00570 PP=BB*AA
00580 DELTA1=(M1*(LL**2)*CC)/2
00590 DELTA2=(PP*(LL**3)*CC)/3
00595 DELTA=DELTA1+DELTA2
00596 ANGLE=THETA*180/PI
00600 PRINT 65,ANGLE,BEND,STRESS,DELTA*F1
00610 65 FORMAT(F6.1,5X,F10.2,6X,E11.3,3X,F10.3,7X,F6.1)
00700 IF(THETA.GT..5382) GO TO 80
00710 THETA=THETA+.017453292
00730 GO TO 60
00800 80 STOP
00810 END

```

```

000000 V-4 STEERING SYSTEM
000010 THIS PROGRAM CALCULATES THE STEERING LOADS ON THE THRU-TILT
000020 STEERING SYSTEM FOR A GIVEN STEERING TORQUE MEASURED AT THE
000030 ENGINE PIVOT POINT. -MVS
000090 REAL I,M1,M2,LL
00100 A=8.0
00110 Z=3.938
00120 X=.615
00130 D=11.44
00140 C=.310
00150 F=.2275
00160 E=30*10**6
00170 PI=3.141592
00180 Y=5.5
00200 THETA=-.5582 ;
00220 I=(PI*(C**4-F**4))/4
00230 CC=1/(E*I)
00300 TYPE 10
00310 10 FORMAT(' ENTER STEERING TORQUE IN FT-LBS')
00320 20 ACCEPT 30,T
00330 30 FORMAT(1F)
00335 TYPE 15
00336 15 FORMAT('//20X, V-4 THRU-TILT STEERING LOADS')
00400 TYPE 40,T
00410 40 FORMAT('//,18H STEERING TORQUE =,F6.1,7H FT-LBS)
00420 TYPE 45
00430 45 FORMAT('// ANGLE BENDING MOMENT MAXIMUM STRESS
00431% 'DEFLECTION CABLE FORCE')
00440 TYPE 50
00450 50 FORMAT(3X, 'DE5',9X, 'FT-LBS',12X, 'PSI',12X, 'IN',10X, 'LBS')
00500 60 AA=(A*COS(THETA)-Z-X)/D
00510 BB=(12*T/A)/COS(THETA-ASIN(AA))
00520 M1=(X*COS(ASIN(AA)))*BB
00525 F1=COS(ASIN(AA))*BB
00530 M2=BB*AA*(D*COS(ASIN(AA))+A*SIN(THETA)-Y)
00540 BEND=(M1+M2)/12
00550 STRESS=(BEND*12*C)/I
00560 LL=D*COS(ASIN(AA))+A*SIN(THETA)-Y
00570 PP=BB*AA
00580 DELTA1=(M1*(LL**2)*CC)/2
00590 DELTA2=(PP*(LL**3)*CC)/3
00595 DELTA=DELTA1+DELTA2
00596 ANGLE=THETA*180/PI
00600 PRINT 65,ANGLE,BEND,STRESS,DELTA,F1
00610 65 FORMAT(F6.1,5X,F10.2,6X,E11.3,3X,F10.3,7X,F6.1)
00700 IF(THETA.GT..5582) GO TO 80
00710 THETA=THETA+.017453292
00730 GO TO 60
00800 80 STOP
00810 END

```

50 H.P. THRU-TILT STEERING LOADS

STEERING TORQUE = 500.0 FT-LBS

ANGLE DEG	BENDING MOMENT FT-LBS	MAXIMUM STRESS PSI	DEFLECTION IN	CABLE FORCE LBS
-32.0	57.39	0.415E+05	0.004	935.8
-31.0	58.42	0.422E+05	0.005	927.7
-30.0	59.52	0.430E+05	0.005	919.7
-29.0	60.71	0.438E+05	0.006	911.7
-28.0	61.96	0.446E+05	0.007	903.9
-27.0	63.27	0.457E+05	0.008	896.2
-26.0	64.64	0.467E+05	0.010	888.6
-25.0	66.07	0.477E+05	0.011	881.1
-24.0	67.55	0.488E+05	0.012	873.8
-23.0	69.07	0.499E+05	0.014	866.6
-22.0	70.64	0.510E+05	0.015	859.5
-21.0	72.24	0.522E+05	0.017	852.6
-20.0	73.87	0.534E+05	0.019	845.9
-19.0	75.52	0.546E+05	0.021	839.3
-18.0	77.20	0.558E+05	0.023	832.8
-17.0	78.90	0.570E+05	0.026	826.6
-16.0	80.61	0.582E+05	0.028	820.5
-15.0	82.33	0.595E+05	0.031	814.6
-14.0	84.06	0.607E+05	0.034	808.8
-13.0	85.79	0.620E+05	0.037	803.3
-12.0	87.51	0.632E+05	0.040	797.9
-11.0	89.23	0.645E+05	0.044	792.7
-10.0	90.94	0.657E+05	0.048	787.8
-9.0	92.63	0.669E+05	0.052	783.0
-8.0	94.31	0.681E+05	0.056	778.5
-7.0	95.96	0.693E+05	0.060	774.1
-6.0	97.59	0.705E+05	0.064	770.0
-5.0	99.19	0.717E+05	0.069	766.1
-4.0	100.75	0.728E+05	0.074	762.4
-3.0	102.29	0.739E+05	0.079	758.9
-2.0	103.78	0.750E+05	0.085	755.7
-1.0	105.23	0.760E+05	0.090	752.7
0.0	106.63	0.770E+05	0.096	750.0
1.0	107.98	0.780E+05	0.102	747.5
2.0	109.28	0.790E+05	0.109	745.2
3.0	110.52	0.799E+05	0.115	743.2
4.0	111.70	0.807E+05	0.122	741.5
5.0	112.82	0.815E+05	0.129	740.0
6.0	113.87	0.823E+05	0.136	738.8
7.0	114.86	0.830E+05	0.143	737.9
8.0	115.76	0.836E+05	0.150	737.3

continued

9.0	116.59	0.842E+05	0.159	737.0
10.0	117.34	0.843E+05	0.165	737.0
11.0	118.01	0.852E+05	0.173	737.3
12.0	118.58	0.857E+05	0.181	737.9
13.0	119.06	0.860E+05	0.189	738.8
14.0	119.45	0.863E+05	0.197	740.1
15.0	119.72	0.865E+05	0.205	741.7
16.0	119.91	0.866E+05	0.213	743.7
17.0	119.93	0.867E+05	0.221	745.0
18.0	119.93	0.868E+05	0.229	748.8
19.0	119.76	0.865E+05	0.237	751.9
20.0	119.47	0.863E+05	0.245	755.5
21.0	119.04	0.860E+05	0.253	759.4
22.0	118.48	0.856E+05	0.260	763.9
23.0	117.77	0.851E+05	0.267	768.8
24.0	116.92	0.848E+05	0.274	774.2
25.0	115.90	0.837E+05	0.281	780.1
26.0	114.72	0.829E+05	0.287	786.5
27.0	113.36	0.819E+05	0.293	793.6
28.0	111.81	0.808E+05	0.299	801.2
29.0	110.07	0.795E+05	0.304	809.4
30.0	108.12	0.781E+05	0.308	818.4
31.0	105.96	0.765E+05	0.311	828.0
32.0	103.56	0.748E+05	0.314	838.4

V-4 THRU-TILT STEERING LOADS

STEERING TORQUE = 500.0 FT-LBS

ANGLE DEG	BENDING MOMENT FT-LBS	MAXIMUM STRESS PSI	DEFLECTION IN	CABLE FORCE LBS
-32.0	78.57	0.553E+05	0.005	1009.7
-31.0	78.52	0.554E+05	0.007	998.1
-30.0	80.13	0.579E+05	0.008	986.8
-29.0	82.01	0.598E+05	0.009	975.5
-28.0	83.94	0.606E+05	0.010	964.6
-27.0	85.93	0.621E+05	0.012	953.9
-26.0	87.97	0.635E+05	0.013	943.3
-25.0	90.05	0.651E+05	0.015	932.9
-24.0	92.18	0.666E+05	0.017	922.8
-23.0	94.34	0.682E+05	0.019	912.8
-22.0	96.53	0.697E+05	0.021	903.1
-21.0	98.76	0.713E+05	0.023	893.6
-20.0	101.00	0.730E+05	0.025	884.3
-19.0	103.27	0.746E+05	0.028	875.3
-18.0	105.55	0.763E+05	0.031	866.5
-17.0	107.84	0.779E+05	0.034	857.9
-16.0	110.15	0.796E+05	0.037	849.6
-15.0	112.45	0.812E+05	0.041	841.4
-14.0	114.76	0.829E+05	0.044	833.6
-13.0	117.06	0.846E+05	0.048	826.0
-12.0	119.36	0.862E+05	0.052	818.6
-11.0	121.65	0.879E+05	0.057	811.4
-10.0	123.93	0.895E+05	0.062	804.5
-9.0	126.18	0.912E+05	0.067	797.9
-8.0	128.42	0.928E+05	0.072	791.5
-7.0	130.64	0.944E+05	0.077	785.4
-6.0	132.83	0.960E+05	0.083	779.6
-5.0	135.00	0.975E+05	0.089	774.0
-4.0	137.13	0.991E+05	0.096	768.6
-3.0	139.23	0.101E+06	0.103	763.5
-2.0	141.29	0.103E+06	0.110	758.7
-1.0	143.31	0.104E+06	0.117	754.2
0.0	145.29	0.105E+06	0.125	749.9
1.0	147.22	0.106E+06	0.133	745.9
2.0	149.10	0.108E+06	0.141	742.2
3.0	150.94	0.109E+06	0.150	738.8
4.0	152.72	0.110E+06	0.159	735.6
5.0	154.44	0.112E+06	0.168	732.8
6.0	156.11	0.113E+06	0.177	730.2
7.0	157.72	0.114E+06	0.187	727.9

continued

E-86

8.0	159.27	0.115E+06	0.197	725.9
9.0	160.75	0.116E+06	0.208	724.2
10.0	162.16	0.117E+06	0.219	722.8
11.0	163.50	0.118E+06	0.230	721.8
12.0	164.77	0.119E+06	0.241	721.0
13.0	165.96	0.120E+06	0.253	720.6
14.0	167.08	0.121E+06	0.264	720.5
15.0	168.11	0.121E+06	0.276	720.7
16.0	169.06	0.122E+06	0.289	721.3
17.0	169.93	0.123E+06	0.301	722.2
18.0	170.70	0.123E+06	0.314	723.5
19.0	171.39	0.124E+06	0.326	725.1
20.0	171.97	0.124E+06	0.339	727.2
21.0	172.46	0.125E+06	0.352	729.6
22.0	172.85	0.125E+06	0.365	732.4
23.0	173.13	0.125E+06	0.378	735.7
24.0	173.30	0.125E+06	0.391	739.4
25.0	173.38	0.125E+06	0.404	743.5
26.0	173.30	0.125E+06	0.416	748.1
27.0	173.11	0.125E+06	0.429	753.2
28.0	172.80	0.125E+06	0.442	758.8
29.0	172.35	0.125E+06	0.454	764.9
30.0	171.76	0.124E+06	0.466	771.6
31.0	171.03	0.124E+06	0.478	778.9
32.	170.14	0.123E+06	0.489	786.8