

AD-A035 601

BOEING COMMERCIAL AIRPLANE CO SEATTLE WASH
ADHESIVE BONDED AEROSPACE STRUCTURES STANDARDIZED REPAIR HANDBO--ETC(U)
MAY 76 J E MCCARTY, R E HORTON, M C LOCKE F33615-73-C-5171
AFML-TR-76-65 NL

F/G 1/3

UNCLASSIFIED

1 of 1
ADA035601

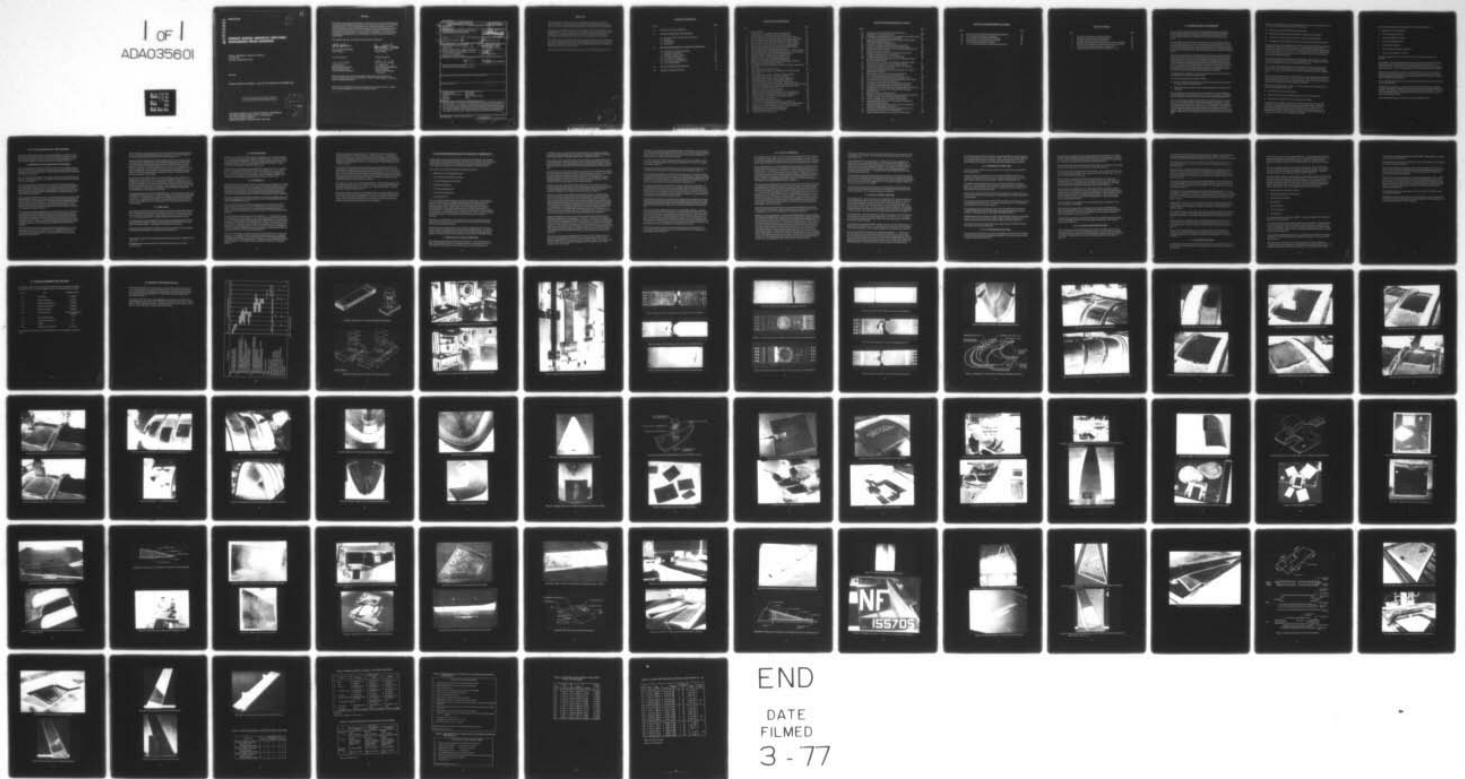

END

DATE
FILMED
3 - 77

ADA 035601

AFML-TR-76-65

(1)

FB

ADHESIVE BONDED AEROSPACE STRUCTURES STANDARDIZED REPAIR HANDBOOK

*BOEING COMMERCIAL AIRPLANE COMPANY
P.O. BOX 3707
SEATTLE, WASHINGTON 98124*

MAY 1976

PHASE III REPORT FOR PERIOD 1 JANUARY 1975 THROUGH 30 SEPTEMBER 1975

Approved for public release; distribution unlimited

DDC
REGISTERED
FEB 14 1977

A
1473

AIR FORCE MATERIALS AND FLIGHT DYNAMICS LABORATORIES
AIR FORCE WRIGHT AERONAUTICAL LABORATORIES
AIR FORCE SYSTEMS COMMAND
WRIGHT-PATTERSON AIR FORCE BASE, OHIO 45433

NOTICE

When Government drawings, specifications, or other data are used for any purpose other than in connection with a definitely related Government procurement operation, the United States Government thereby incurs no responsibility nor any obligation whatsoever; and the fact that the Government may have formulated, furnished, or in any way supplied the said drawings, specifications, or other data, is not to be regarded by implication or otherwise as in any manner licensing the holder or any other person or corporation, or conveying any rights or permission to manufacture, use, or sell any patented invention that may in any way be related thereto.

This technical report has been reviewed and is approved for publication.

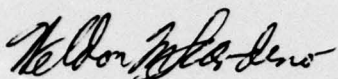

W. M. Scardino (AFML/MXE)
Project Engineer

For the Commander

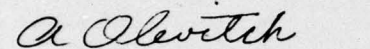

A. Olevitch, Chief
Materials Engineering Branch
Systems Support Division
Air Force Materials Laboratory



H. Croop (AFFDL/FBS)
Project Engineer

For the Commander

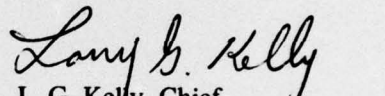

L. G. Kelly, Chief
Structural Development Branch
Structures Division
Air Force Flight Dynamics
Laboratory

This report has been reviewed by the Information Office (IO) and is releasable to the National Technical Information Service (NTIS). At NTIS, it will be available to the general public, including foreign nations.

Copies of this report should not be returned unless return is required by security considerations, contractual obligations, or notice on a specific document.

UNCLASSIFIED

SECURITY CLASSIFICATION OF THIS PAGE (When Data Entered)

19 REPORT DOCUMENTATION PAGE		READ INSTRUCTIONS BEFORE COMPLETING FORM
1. REPORT NUMBER AFMLTR-76-65 ✓	2. GOVT ACCESSION NO.	3. RECIPIENT'S CATALOG NUMBER 9
4. TITLE (and Subtitle) ADHESIVE BONDED AEROSPACE STRUCTURES STANDARDIZED REPAIR HANDBOOK ✓		5. TYPE OF REPORT & PERIOD COVERED Phase III Report 1 Jan 1975 through 30 Sep 1975 6. PERFORMING ORG. REPORT NUMBER on Phase 3
7. AUTHOR(s) J. E. McCarty, R. E. Horton, et al. M. C. Locke B. D. Parashav (15)		8. CONTRACT OR GRANT NUMBER(s) F33615-73-C-5171 ✓
9. PERFORMING ORGANIZATION NAME AND ADDRESS Boeing Commercial Airplane Company P.O. Box 3707 Seattle, Washington 98124 (17) 06, 02		10. PROGRAM ELEMENT, PROJECT, TASK AREA & WORK UNIT NUMBERS Project 73810677 (AFML) Project 13680213 (AFFDL)
11. CONTROLLING OFFICE NAME AND ADDRESS Air Force Materials and Flight Dynamics Laboratory Air Force Systems Command Wright-Patterson AFB, Ohio 45433 (11)		12. REPORT DATE May 76
14. MONITORING AGENCY NAME & ADDRESS (if different from Controlling Office) (12) 75 p.		13. NUMBER OF PAGES 66
		15. SECURITY CLASS. (of this report) Unclassified
16. DISTRIBUTION STATEMENT (of this Report) Approved for public release; distribution unlimited.		
17. DISTRIBUTION STATEMENT (of the abstract entered in Block 20, if different from Report)		
18. SUPPLEMENTARY NOTES 62102 F 62201 F		
19. KEY WORDS (Continue on reverse side if necessary and identify by block number) Adhesive bonding Metal bonding Standardized repair handbook Aircraft repair Sandwich Bonded aerospace structure Honeycomb Repair Handbook		
20. ABSTRACT (Continue on reverse side if necessary and identify by block number) This report covers the third phase of a five-phase program to develop a standardized handbook for the repair of bonded aircraft structure. Tasks include the standardization of small repairs that are now covered by the various aircraft technical orders as well as general instructions for large repair work, including component rebuilding. Work completed in Phase III included the fabrication and test of small area repair specimens. Repair methods were demonstrated on seven military aircraft components. This work will serve as a base for procedures to be designated in the handbook.		

390 145

net

TABLE OF CONTENTS

Section		Page
1.0	INTRODUCTION AND SUMMARY	1
2.0	EVALUATION OF SMALL AREA REPAIRS	4
	2.1 Description of The Test Specimens and Program	4
	2.2 Fabrication	5
	2.3 Test Procedures	6
	2.4 Test Results	6
3.0	REPAIR DEMONSTRATION ON AIRCRAFT COMPONENTS	8
	3.1 Simulated C-141 Wing Leading Edge	8
	3.2 C-141 APU Access Panel	11
	3.3 T-38 Main Landing Gear Door	12
	3.4 T-38 Horizontal Stabilator	13
	3.5 F-111 Titanium Fuselage Panel	13
	3.6 C5-A Aileron Trailing Edge Panel	14
	3.7 A-6 Vertical Fin Panel	15
4.0	REPAIR HANDBOOK PREPARATION	18
5.0	PHASE IV FOLLOW-ON PLANS	19

LIST OF ILLUSTRATIONS

Figure		Page
1	Program Schedule	20
2	Configuration of the Small Area Repair Test Specimens	21
3	Exploded View of the Small Area Repair Test Specimens	21
4	Small Area Repair Control Specimen Mounted for Tensile Testing	22
5	Small Area Repair Control Specimen Mounted for Compression Testing	22
6	Small Area Repair Control Specimen Mounted for Fatigue Testing	23
7	Repaired Aluminum Specimen After Tensile Test—AF127-3 Adhesive	24
8	Repaired Titanium Specimen After Tensile Test—FM400 Adhesive	24
9	Titanium Compression Control Specimen Showing Edge Crippling	24
10	Titanium Compression Repair Specimen After Test	25
11	Typical Fatigue Failure—Repaired Aluminum Specimen—AF127-3 Adhesive	25
12	Typical Fatigue Failure—Repaired Aluminum Specimen—AF130 Adhesive	25
13	Base Metal Failure—Repaired Titanium Fatigue Specimen	26
14	Repair Area Failure—Titanium Fatigue Specimen (3-7)	26
15	Repair Area Failure—Titanium Fatigue Specimen (3-8)	26
16	Simulated C-141 Wing Leading Edge After Fabrication	27
17	Breakdown of the Simulated C-141 Wing Leading Edge Construction	27
18	Removing Core With the High Speed Cutter	28
19	Core Removed With Bare Metal Areas to Demonstrate Surface Preparation Techniques	28
20	Profit of Replacement Honeycomb Core	29
21	Start of Hand Anodize Procedure—Phosphoric Acid Applied to Bare Metal Surface	29
22	Gauze Applied Over Acid Gel—Additional Gel Being Applied	30
23	Stainless Steel Screen in Place—Anodizing in Progress	30
24	Anodizing Complete—Surface Ready for Primer Application	31
25	Surface Preparation of the Second Bay With PasaJell 105	31
26	Surface Preparation of the Third Bay With 2% Hydrofluoric Acid	32
27	Application of Alodine 1200 to the Third Bay Surface After Acid Treatment	32
28	Application of EC3921 Adhesive Primer Using a Preval Power Unit	33
29	Application of the AF127-3 Adhesive Film	33
30	Application of the Core Splicing Compound	34
31	Replacement Core Installed—Assembly Ready for First-Stage Cure	34
32	Repaired C-141 Wing Leading Edge Ready for the First-Stage Cure	35
33	Details for Repair of a Void in the Leading Edge Assembly	35
34	Completed Repair of Void Area	36
35	C-141 Wing Leading Edge After Rebuild	36
36	C-141 APU Access Panel Received From Warner Robins ALC	37
37	Damaged Access Panel and Molded Fiberglass Bond Assembly Jig (BAJ)	37
38	Exploded View of Repair Details for the C-141 APU Access Panel	38
39	Damaged Removed and the Repair Details Shown	38
40	Roto-Peening the Patch Plate to Proper Contour	39
41	Cutting the Adhesive Film to Size	39

LIST OF ILLUSTRATIONS (Continued)

Figure		Page
42	Attachment of the Fiberglass BAJ to the Panel Surface	40
43	Installation of the Core Splice Adhesive	40
44	Positioning the Stainless Steel Screen for Anodizing the Metal Bond Surface	41
45	C-141 APU Access Panel Repair—Cure in Progress	41
46	Inspection of the Repaired C-141 APU Access Panel—Water Coupled Through Transmission Ultrasonics	42
47	C-141 APU Access Panel—Repaired Panel	42
48	T-38 Main Landing Gear Door Received From Nellis AFB	43
49	Removal of Delaminated Doubler and Simulated Edge Damage	43
50	Exploded View of Repair Details for the T-38 Main Landing Gear Door	44
51	Repair Details Prior to Assembly	44
52	T-38 Main Landing Gear Door After Bonding the Repair Details	45
53	T-38 Main Landing Gear Door—Repaired Panel	45
54	T-38 Horizontal Stabilator Received From Kelly AFB	46
55	T-38 Horizontal Stabilator Showing Simulated Trailing Edge Damage Removed and Repair Details	46
56	Cross Section of the T-38 Horizontal Stabilator Trailing Edge Repair	47
57	Anodizing the Patch Plates for the T-38 Stabilator Repair	47
58	Closeup of the T-38 Horizontal Stabilator Repair After Bonding	48
59	T-38 Horizontal Stabilator After Repair	48
60	Damaged Aircraft Parts Received From Nellis AFB (F-111 Titanium Fuselage Panel at Bottom)	49
61	Repair Details for F-111 Titanium Fuselage Panel Section	49
62	F-111 Titanium Fuselage Panel Section After Repair	50
63	C5-A Aileron Trailing Edge Panel Received From Dover AFB	50
64	Interior Condition of C5-A Aileron Trailing Edge Panel Prior to Repair	51
65	C5-A Aileron Trailing Edge Part Breakdown	51
66	Anodizing the Lower Half of the C5-A Trailing Edge Panel Skin	52
67	C5-A Aileron Trailing Edge Repair Details Ready for Bonding	52
68	Trailing Edge Panel After Collapse From Autoclave Pressure During Cure	53
69	Tooling Concept to Support the Trailing Edge Panel During the Rebuilding Cure	53
70	Rebuilt C5-A Aileron Trailing Edge Panel	54
71	Damaged A-6 Vertical Fin Received From the Norfolk Naval Air Station	54
72	Closeup of Damage to the A-6 Fin Panel Exterior Surface	55
73	Closeup of Damage to the A-6 Fin Panel Interior Surface	55
74	Cosmetically Filled Fin Panel to be Used as Base for Molding the Fiberglass Bond Assembly Jig	56
75	Metal Contour Sheet Placed Over the Panel to Provide a Surface for Molding the Fiberglass Bond Assembly Jig	56
76	Fin Panel and Fiberglass Bond Assembly Jig Being Bagged for Cure	57
77	Detail Cross-Sections of the A-6 Fin Panel Repair	58
78	Mylar Template to Define the Core Outline and Edge Recesses	59

LIST OF ILLUSTRATIONS (Concluded)

Figure		Page
79	Machining the Core With the High-Speed Surfacing Machine	59
80	A-6 Fin Repair Details Ready for Assembly	60
81	Exterior Surface of the Fin Panel After Bonding	60
82	Interior Surface of the Fin Panel After Bonding	61
83	A-6 Vertical Fin With Repair Completed	61
84	F-111 Outboard Spoiler Received From Sacramento ALC	62

LIST OF TABLES

Table		Page
1	Test Plan for Small Laboratory Repair Specimens	62
2	Materials Used in Small Area Repair Specimens	63
3	Curing Procedures for Adhesives and Primers	63
4	Procedure Used to Prepare the Aluminum Skin Surfaces for Bonding	64
5	Procedure Used to Prepare the Titanium Skin Surfaces for Bonding	64
6	Test Results for the Small Area Static Test Specimens	65
7	Fatigue Test Results for the Small Area Repairs (R = -1.0)	66

1.0 INTRODUCTION AND SUMMARY

The use of adhesive bonding in aircraft structures has expanded greatly in recent years, broadening from use in secondary structures to considerable use in primary applications. Because adhesive bonding is now being used extensively by all manufacturers, repairs involving bonded components are an important part of the military maintenance depot activity.

The rapid expansion of this technology has created many new repair requirements. Important to this repair technology is the need for improvement and standardization of the repair procedures, and providing instruction for large repair and rebuilding as well as for the small patches. Procedures must be kept up to date. If the repairs are to be accomplished efficiently, procedures must be consistent for repairing similar types of structure on various manufacturers' aircraft.

At the present time, procedural coverage for adhesive bonded structure repair meeting these requirements is lacking. Instructions for large repairs are quite limited. Repair documents, technical orders (T.O.), typically cover only small repairs and are developed by each manufacturer using his own preferred manufacturing methods and materials. This creates difficulties, especially since an individual depot may repair several different models or types of aircraft. A mechanic may repair similar damage on several types of aircraft and be instructed to use different materials and methods on each. In addition to the procedural confusion, the situation results in an unnecessarily large material inventory. Keeping the many T.O.'s up to date with current methods and materials development is also difficult.

This program has been undertaken to remedy these situations and to increase the efficiency of repairing bonded components on military aircraft.

The major goals of this program are defined as follows:

- Develop a standardized material list and standardized repair and inspection procedures for small area repairs on military aircraft
- Provide a repair guide for major repairs or rebuilding of large areas of bonded aircraft components

This five-phase program is to be performed over a 3-year period. The tasks and program schedule defined for each phase are shown in figure 1. The first three phases of this program have been completed. This document reports on the work accomplished during Phase III.

Phase I was accomplished during the initial 6 months of the program, starting on 1 October 1973. The work consisted primarily of information gathering and cataloging. A comprehensive review was made of pertinent Air Force T.O.'s. Repair geometries were cataloged, and material lists were extracted for various service and cure temperatures. In addition, visits were made to several military and commercial repair depots and airframe manufacturers' facilities. Insight was obtained into such areas as to types of damage incurred, current repair materials and procedures used, availability of facilities and equipment, and level of personnel skills.

Phase II was accomplished over the 9-month period from 1 April 1974 to 31 December 1974. The tasks performed in Phase II consisted of the following:

- Definition of the handbook outline and repair criteria
- Definition of the small area repair methods to be included in the handbook
- Evaluation of candidate adhesive systems and surface preparation methods
- Participation in a joint military/industry repair handbook workshop at Dayton, Ohio

Eighteen adhesive systems and approximately 16 surface preparation methods were evaluated during Phase II. With the exception of some of the new generation epoxy systems, the adhesives were largely those currently used at the repair depots and included systems curing at room temperature, 250°F, and 350°F. The surface preparation methods included solvent and acid hand cleaning and acid tank cleaning. Development work was done using a phosphoric acid hand-cleaning procedure.

Test results confirmed the superiority of the new generation epoxy systems, the elevated temperature curing adhesives, and the acid-cleaning methods. The suitability of a particular cleaning method depends greatly on the specific adhesive system.

Phase II of the program was terminated with a joint military/industry workshop held at Dayton, Ohio. The workshop afforded an opportunity to review the handbook program status and to incorporate the suggestions from aircraft manufacturers and future handbook users.

Basically, the handbook will contain specific instructions for accomplishing small repairs and general instructions for large repairs. The goal is that the repairs restore the structure to its original strength. Repairs will be of a permanent quality. Design objectives are to minimize weight and cost while giving maximum emphasis to durability.

Phase III of the program began 1 January 1975 and was completed on 30 September 1975. The work was conducted in three areas:

- Repair and test of small repair specimens
- Repair and evaluation of components furnished by the Air Force and Navy
- Preparation of initial drafts of several of the handbook sections

Evaluation of the small repairs involved the fabrication of 30 sandwich test specimens. Two-thirds of the specimens were aluminum and one-third were titanium. Half of the specimens were damaged simulating a hole through both surfaces. These were then repaired and a comparison made between the repaired and undamaged controls. The adhesives used were those currently being used for the repair of Air Force aircraft. The specimens were tested in tension, compression, and fatigue.

Repair method demonstrations included repair of the following components:

1. Simulated C-141 wing leading edge
2. F-111 fuselage panel (titanium)
3. T-38 main landing-gear wheel door
4. C5-A aileron trailing-edge panel
5. T-38 horizontal stabilator
6. C-141 double-contoured APU access panel
7. A-6 vertical fin (supplied by the Navy)

An eighth component, an F-111 outboard spoiler, will be repaired and tested during Phase IV.

The simulated C-141 wing leading-edge component was fabricated during Phase II. During Phase III, a major part of the component was rebuilt simulating work being done at the Warner Robins ALC. This included removal and replacement of the outer skin and a major portion of the core. The use of three different acid-type cleaning methods was investigated.

Repair work was completed on the other six components listed. The F-111 titanium fuselage panel was repaired using PasaJell 107 as the surface preparation method for bonding. Surface preparation for the aluminum components was done using the phosphoric acid hand-anodize method developed in Phase II.

The accomplished repair work was successful in giving an important insight into procedure to be used in the handbook.

In addition to the repair work, a significant part of the repair handbook was completed in Phase III. This included the subjects of materials, surface preparation, small area repair, and nondestructive inspection. This preparation work will continue during Phase IV. Other work to be accomplished in Phase IV will be the repair and test of an F-111 spoiler. The handbook will be finalized in Phase V.

The various Phase-III tasks are discussed in detail in the following sections.

2.0 EVALUATION OF SMALL AREA REPAIRS

The work to evaluate small area repairs gave important information on the effect of these types of repairs on structural strength. The work also afforded an opportunity to evaluate adhesive systems currently used by the Air Force and to demonstrate application of the newly developed phosphoric acid hand-anodize surface treatment for aluminum.

2.1 DESCRIPTION OF THE TEST SPECIMENS AND PROGRAM

This work was limited to the evaluation of small area repair in the center region of a sandwich panel. Repair of the sandwich structure gave information that was applicable for both sandwich and metal laminate construction. Typical edge repair techniques were subsequently demonstrated on components.

One type of small repair configuration was evaluated, the repair of a hole through both sandwich faces. A flush repair was made on one surface with a nonflush patch plate on the other. This can be seen in figure 2.

This type of repair is the most involved of the small repairs in the center panel region; i.e., more involved than a repair to one surface only or a repair accomplished by the installation of two symmetrical nonflush patch plates. The flush surface patch also requires that a larger size hole be cut in the skin for a particular damage size. As such, this repair should be most critical from a strength standpoint. Any indications of strength loss should be conservative for other repair types.

Thirty specimens were fabricated and tested. The types of specimens can be seen in the brief test plan in table 1. There were six tension, six compression, and 18 fatigue specimens. Of these, half were fabricated with repairs. The other half were straight undamaged sandwich specimens and were used as comparative controls. The specimens included sandwich with aluminum and titanium skins and the use of three different adhesive systems. A more detailed description of the test specimens including the material identification can be seen by the combination of figure 3 and table 2.

The static tension and fatigue specimens were 6.0 in. wide and 24 in. long. A 6.0-in. minimum width was required to accommodate the width of the circular patch plates. This width also allowed the use of standard test grips that were already available. The 24.0 in. length allowed for installation of bonded end doublers and distance for the end loads to feed gradually into the repair area. The specimen length was shortened to 16.0 in. for the compression specimens. This was because the end doublers were not required for compression testing and also to prevent the specimens from failing prematurely from general instability.

The three adhesives selected are currently being used in the fleet for repair. AF 127-3 is being used for repair of the C-5A, AF130 for the F-111, and FM400 for the F-15. The curing temperature for AF127-3 is 250°F. AF130 and FM400 cure at 350°F. These adhesives were evaluated during Phase II of this program. Results from previous work were used in the repair design.

The face thicknesses were selected so that the faces would be within the strength capabilities of the AF130 and FM 400 adhesive systems. This is based on test values obtained for the adhesives during Phase II and included in the Phase II report (ref. 1).

The typical ultimate strength for the 2024-T3 aluminum is 70 ksi (ref. 2). Based on this, 0.020-in. faces were selected giving a typical strength of 1400 pounds per inch of width. The strength versus overlap tests previously obtained for AF130 gave almost a constant strength of 1500 lb/in. of width for overlaps from 0.5 to 2.0 in. (ref. 1). Because the adhesive is quite brittle, a two-stepped laminate patch was used for the large hole. The first lamina was 0.010 with a 1.25-in. overlap. The second lamina was 0.010 with an 0.75-in. overlap. The patch for the small hole was considered less critical. A single-layer 0.020 patch was used with a 1.00-in. overlap.

By contrast to the AF130, the strength of the AF127-3 adhesive was not critical. The strength previously obtained for a 1-in. overlap was approximately 3700 lb/in. (ref. 1). The strength increased appreciably with the overlap length. This indicated that much thicker sandwich faces could be successfully patched with this adhesive system than with the AF130. For these tests, 0.020 faces were used to provide a direct comparison to those repaired with the AF130 system. A patch with a 1-in. overlap was used in accordance with previous criteria established to ensure adequate panel sealing.

The titanium specimens were bonded with FM400 adhesive. Typical ultimate strength of the annealed 6Al-4V titanium is 145 ksi. An 0.012 face thickness was used giving a face strength of 1740 lb/in. The strength obtained in Phase II for FM400 was approximately 2000 lb/in. of width (ref. 1). Again, similar to the AF130, this was almost constant over the 0.50- to 2.00-in. overlap length range. An 0.12 thick patch with a 1.00-in. overlap length was used for both surfaces.

2.2 FABRICATION

Since these were small repairs, the procedures used were planned to typify field repair conditions. The surfaces were hand cleaned. The adhesives were cured at the minimum temperatures considered to be acceptable. Vacuum bags were used for curing rather than an autoclave. The curing procedures for the adhesives and primer systems are given in table 3.

The aluminum surfaces were prepared for bonding using the phosphoric acid hand-anodize method developed in Phase II. The procedure is listed in table 4. PasaJell 107 was used to prepare the titanium surfaces. The PasaJell 107 procedure is listed in table 5.

All specimens were nondestructively inspected after fabrication using C-scan water coupled through transmission ultrasonics. No significant defects were noted.

¹ Adhesive Bonded Aerospace Structures Standardized Repair Handbook, Phase II Report, AFML-TR-75-158, August 1975.

² MIL-HDBK-5, Military Standardization Handbook, Metallic Materials and Elements for Aerospace Vehicle Structures.

2.3 TEST PROCEDURES

All tests were conducted at ambient laboratory temperature in air. The static specimens were tested with a standard setup in a Baldwin 120,000-lb capacity universal test machine. The rate of loading was 4000 lb/min. Load versus machine head travel curves were automatically recorded on a Satec x-y plotter through a PD-1M deflectometer. Typical mountings of the specimens are shown in figures 4 and 5.

Fatigue tests were accomplished in a Sonntag SF-10-U equipped with a 2-to-1 load multiplier. The cyclic load rate was 1800 cpm. All tests were conducted at a stress ratio of $R = -1.0$. A typical test setup is shown in figure 6. The load levels were adjusted in an attempt to obtain failure of the control specimens between 50,000 and 100,000 cycles. This represents a reasonable ground-air-ground cycle life with a factor of 4.0.

2.4 TEST RESULTS

Results of the static tests are given in table 6. In general, the static strengths of the repaired specimens were quite close to those of the controls. Some results, both higher and lower than the controls, were expected due to normal scatter. Also there is some tendency of the adhesive bond to fail slightly lower than the ultimate metal strength because of the high plastic metal deformation. This is especially the case for bonds to highly ductile metals such as 2024-T3 aluminum and the 6Al-4V annealed titanium used in this program.

It should be noted that these results are applicable to only the skin thicknesses tested. For thicker skins, the strength of the adhesive may be critical. This is particularly true for the AF130 and FM400 adhesive systems.

The test value for the repaired aluminum tensile specimen (1-5) bonded with AF127-3 adhesive was 6% lower than the control. The failing load for the specimen represents a stress of 62,300 psi in the aluminum. The metal showed appreciable necking at this stress, and the skin essentially peeled from under the patch. The failed specimen is shown in figure 7.

The repaired titanium tensile specimen (3-5) also failed low: i.e., 12% below the control. The failed specimen is shown in figure 8. The stress in the annealed 6Al-4V titanium was in excess of 130 ksi; the metal was beginning to yield. FM400 adhesive is quite brittle and will tolerate very little plastic metal deformation prior to failure. Also, at failure the load was 1570 lb/in. of skin width. This is probably not unrepresentative of the strength of an FM400 bond to hand-cleaned titanium. No tests were made on titanium during Phase II; however, the strength of FM400 on tank-cleaned aluminum was approximately 2000 lb/in. It was appreciably less on hand-cleaned aluminum (ref. 1).

In the case of the titanium compression specimens, the repaired specimen was appreciably stronger. It is concluded that the control specimen failed prematurely due to crippling of the skin at the panel edge. This can be seen in figure 9. A more representative failure was obtained with the repaired specimen as seen in figure 10; hence, the specimen attained a higher failing load. It was concluded that the repair did not degrade the compression properties.

Results of the fatigue tests are given in table 7. The first of the control specimens was used to adjust the load to obtain failures in the desired cycle range; i.e., approximately 50,000 to 100,000 cycles. After an initial load adjustment, the aluminum specimens were tested with a maximum skin stress of 22 ksi. The results indicated that the repair did not degrade the fatigue properties. Failures were in the base metal. Typical failures are shown in figures 11 and 12.

The initial titanium control specimen was tested with a maximum stress of 40 ksi. The testing machine, equipped with an automatic recorder and shutoff, was left to cycle into the weekend. Consequently, the specimen accumulated an excess of 7×10^6 cycles with no failure. This test value was then used with a plot of standard titanium S-N curves to re-adjust the load to obtain a lower acceptable cyclic life. This resulted in the maximum stress for the remaining two control specimens being set at 60 ksi. As indicated, the failure times were 46,000 and 48,000 cycles and considered acceptable.

The 60-ksi stress was then used for the repaired specimens. The first specimen failed in the base metal on the initial cycle. This is shown in figure 13. The remaining two specimens failed in the repaired area after short cyclic lives; i.e., 1000 and 3000 cycles. The failed specimens are shown in figures 14 and 15.

Discounting the failure of the first of the repaired specimens on the base metal, the cyclic lives of the remaining two repaired titanium specimens were considerably lower than those of the controls. The failures were adhesive (i.e., in contrast to cohesive) from the skin surface. The data indicate that additional work is required on hand-surface preparation methods for titanium if effective repairs are to be accomplished.

3.0 REPAIR DEMONSTRATION ON AIRCRAFT COMPONENTS

Repair methods were demonstrated on seven components during Phase III. This provided an opportunity to work out repair problems that would not have otherwise been encountered. It also provided an opportunity to demonstrate the use of processing methods on larger, more complex parts than were used in the Phase II laboratory development studies.

The parts that were repaired consisted of the following components:

1. Simulated C-141 wing leading-edge section
2. C-141 double-contoured APU access panel
3. T-38 main landing-gear wheel well door
4. T-38 horizontal stabilator
5. C5-A wing trailing-edge panel
6. F-111 titanium fuselage panel
7. A-6 vertical fin panel

The C-141 wing leading-edge component was fabricated during Phase II. An attempt had been made earlier to obtain a damaged leading-edge section from Warner Robins ALC. However, because of limited inventories, all of these parts were being repaired for immediate return to service. Repair work on the C-141 leading-edge was considered especially desirable. It represented a significant part of the repair work being done at Warner Robbins. It additionally provided a large area for demonstration of surface preparation techniques, core removal methods, etc. Because of this, a review was made of Boeing's bonding tool inventory. A suitable bonding tool was found in stock and the part fabricated.

Other parts were obtained from various repair depots. Some excess parts were received. These have been turned over for use in another Air Force contract (F33615-74-C-5065) devoted to bond durability evaluation.

The parts selected for repair represent a variety of repair conditions and several aircraft models. Work on the program has been concentrated on bonded aluminum. One titanium panel was repaired. Repair procedures for titanium will be included in the repair manual. Details of the repairs to the particular components are described in the following sections.

3.1 SIMULATED C-141 WING LEADING EDGE

This component is shown after initial fabrication in figure 16. The component is 54 in. long. It has an 0.040-in. 2024-T3 bare aluminum outer skin. The inner skin is 0.025 in. The lengthwise 45° edge closeouts are formed aluminum. The radial edge closeouts

are fiberglass. The core is 2.00 in. thick 3-15N 5052 aluminum. It has ribs of densified honeycomb running radially at the one-third points. The general construction is illustrated in the sketch in figure 17. Bonding was with 250° F curing AF126 adhesive.

Service damage to this component typically can involve outer skin denting and penetration or edge delamination. This is followed by the entry of moisture into the panel and subsequent core corrosion. The repair demonstrated here was for this type of damage. The work included removal and replacement of the outer skin and the major part of the honeycomb core.

In the procedure, dry ice was used to chill the outer skin to lower the adhesive peel strength. The outer skin was then peeled and removed from the edge members and core. The undensified core sections were subsequently removed using an abrasive disk mounted in a high-speed drill motor. The process is shown in figure 18. The densified core sections at the panel periphery and those used to form the two radial ribs were left intact. These densified sections are not usually part of the corrosion problem.

Following rough core removal with the abrasive disk, the core was moved down to the adhesive surface with a nylon abrasive wheel. Additionally, an area in each bay was cleaned to the bare aluminum skin. These areas were later used to demonstrate metal surface preparation techniques. The component at this stage is shown in figure 19.

The next step consisted of preparing the replacement core details. A nylon fabric was adhesively bonded to one surface of the core. This nylon skin was then used to hold the core in a vacuum chuck while machining to the proper thickness. After machining, the nylon was peeled from the core surface. The core was then formed to the proper curvature using pyramid rolls. Precautions were taken to minimize cell wall distortion, cell crippling, or core crushing. This was done by sandwiching the core between metal caul plates during the rolling operation. A forming cushion was used between the plates and the core. This cushion was made of 181 fiberglass cloth impregnated with Depcoat 5020 plastic film. This sheet was air dried and baked before use. After forming, the core sections were prefit to ensure their proper fit and size. The prefitting operation is shown in figure 20.

Figures 21 through 26 show the procedures used to prepare the bare metal surfaces for bonding; three methods were demonstrated. The first bay was treated by the phosphoric hand-anodize method developed during Phase II. In figure 21, a dam has been made around the bare metal area with aluminized tape. The surface has been coated with the phosphoric acid paste. Layers of gauze have been placed over the acid paste in figure 22. The gauze is being troweled into the paste with a teflon spatula. Figure 23 shows the stainless steel screen in place and the anodizing in progress. The stainless steel screen was used as the cathode. The anodizing was done at 4 volts for 10 minutes. The final prepared surface is shown in figure 24.

The second bay was prepared using PasaJell 105 conversion coating. Again, as shown in figure 25, the aluminum foil was used as a barrier to contain the acid. After 10 to 12 minutes, the PasaJell 105 was removed and the area cleaned thoroughly with distilled water and cheese cloth. The area was then wiped lightly with cheese cloth to remove excess moisture. It was then air dried.

The third bay, shown in figure 26, was prepared using 2% hydrofluoric acid. After etching, the surface was cleaned with distilled water and air dried. Next, Alodine 1200 was applied as shown in figure 27. Surplus material was removed with cheese cloth and distilled water. A golden-brown colored surface remained for bonding.

The cleaned surfaces are shown being primed in figure 28. The primer is EC3921. Application was with a Preval power unit and container. Application of the AF127-3 adhesive film is shown in figure 29.

The potting compound used for splicing the core is shown being applied in figure 30. This is EC3439 which is heat activated. The core sections are shown in place in figure 31.

Curing of the part was done in two stages. In the first stage, the core was bonded in place. The outer skin was rebonded in the second stage. The two-stage process allows intermediate visual inspection for such occurrences as voids in the core splice adhesive, shifting of the core during cure, or the surface of the core not being of the proper level. If these do occur, corrections can be made before the panel is closed in the second bond cycle.

The first-stage cure procedure consisted of covering the assembly with parting film. The outer skin was placed over the core to act as a caul plate. The part was then placed in the bonding tool for cure. The cure was at 250°F for 60 minutes. The autoclave pressure was 35 psi. The part is shown bagged and in the bonding tool in figure 32. After cure, the part was debagged, the core splice material was inspected for adhesion to the core edges, and the surface of the core was examined for proper contour.

In preparation for the final cure, the outer skin was cleaned in the phosphoric acid anodize tanks. The edge details on the component had the original adhesive on their surfaces. This was lightly abraded and solvent wiped. The core surface was also solvent wiped. The film adhesive and the skin were then fitted in place and the part returned to the tool for final cure.

After removal from the bonding tool, the part was ultrasonically inspected. As a result, a void was found between the inner skin and core next to the edge at the radius apex. This measured approximately 4 in. long radially and was about 3 in. wide. It was caused during the first-stage repair bond. The female production bond tool had been used (see fig. 16). The core was positioned next to the tool surface and then covered by the inner skin. The inner skin had been preformed but using the same tool that was used for forming the outer skin. Reliance was on the bonding pressure to push the skin to the tighter inner radius. The bonding pressure used was not sufficient to do this and hence the void.

The part was repaired by removing the skin in the delaminated area and patching. The repair details and the finished patch are shown in figures 33 and 34. The completed part after painting is shown in figure 35.

3.2 C-141 APU ACCESS PANEL

This component, shown in figure 36, was received from the Warner Robins ALC. The part has a double-contoured surface. As received, the part was undamaged. It was decided to use the part to demonstrate the repair of a puncture through both skin surfaces. The outer surface would be smooth to the original contour. The inner patch plate would be nonflush.

Prior to damaging the part, a 16-ply fiberglass laminate was molded to the contour of the exterior surface in the repair area. The laminate was a high temperature prepreg with 181 fiberglass fabric. It was initially cured at 200°F for 2 hours. Subsequent postcure was for 2 hours at 350°F. The contoured laminate was used to shape the repair patches and as a jig to maintain proper part contour during bonding. Normally on a damaged part, this jig would be made after the damage was temporarily filled and cosmetically smoothed or would be made on an undamaged duplicate part. The part with the induced damage and the fiberglass bond assembly jig (BAJ) are shown in figure 37.

After fabricating the fiberglass BAJ, the damaged area was cutout using a high-speed router. An exploded view of the repair is shown in the sketch in figure 38. The details consisted of the flush filler plate, the internal patch plate providing for a minimum 1.00-in. bonded overlap around its edges, the core, and the nonflush patch plate for the inner concave surface. The metal skin patch details were cut to size using standard shop practice. The core detail was surface machined to proper thickness. A mylar template was made and used to define the core shape. These pieces are shown in figure 39. The materials for the repair matched those of the part. The skins were 0.020 2024-T3 aluminum. These were formed to proper contour using a Roto-Peen technique. The plastic BAJ was used to define the proper shape. This process is shown in figure 40. The core was 3-15N 5052 aluminum. Preforming the core was not required.

After forming, the metal patch details were hand cleaned by phosphoric acid anodizing and primed with EC3921 primer. When the primer had dried, the patch plates were used as templates to cut the AF127-3 adhesive film. This is shown in figure 41.

Bonding was a two-stage procedure. Layup procedures began with first a layer of parting film and then the fiberglass BAJ being attached to the exterior surface as shown in figure 42. The part was then inverted. The interior bond surface, which had the original adhesive, and the core edges were solvent wiped. A double-wipe procedure was used. First the area was wet wiped and then dry wiped to pick up any solids; it was then air dried. After drying of the solvent, layup proceeded with the metal patch plug, adhesive film, the internal metal patch plate, and a second layer of adhesive film. As a next step, the core splice adhesive, thermofoam 3050-250, was placed around the edge of the core. This is shown being accomplished in figure 43. Note that all handling of adhesives and contact with cleaned surfaces involves the use of white gloves. Next, the previously cleaned core was pressed into place and the assembly prepared for initial bonding. This was done by placing parting film over the core. The internal patch plate was used as the covering metal caul plate, and the assembly was vacuum bagged and cured. The cure was for 2 hours at 200°F.

Following the first-stage cure, the core area was inspected to ensure that a satisfactory bond was obtained at the core edges. The core surface was checked for levelness with the outer surface of the skin.

Surface preparation for the second-stage cure consisted first of solvent wiping the core surface. The area around the metal surface area to be cleaned was then masked with polyester tape. This included masking of the core cavity. The tape overlapped the metal at the edge of the cavity by approximately 0.060 in. The unmasked area was then phosphoric acid anodized similar to the area prepared for the wing leading-edge section, described previously in section 3.1. The stainless steel screen is being positioned for the anodizing process in figure 44.

After the surface was prepared, the masking tape was removed. The adhesive film and splice plate were secured in position and the assembly prepared for cure. A vacuum bag was used on each surface to obtain pressure. The temperature was obtained through the use of heating blankets covered with asbestos insulating sheet. The cure is shown in progress in figure 45. The cure was again for 2 hours at 200° F.

After curing, the part was inspected using water coupled ultrasonic through transmission. Inspection of the component is shown in figure 46. This indicated that the quality of the repair was satisfactory. The completed part is shown in figure 47.

3.3 T-38 MAIN LANDING GEAR DOOR

The landing gear door that was repaired is shown in figure 48. The door was received from Nellis Air Force Base. Upon receipt, the part was nondestructively inspected. This indicated a sizable delamination under a tear drop doubler on the inner surface. It was decided that this would be removed and rebonded. A repair would also be made to simulated damage at the door edge. The doubler is shown removed in figure 49. The simulated damage area has also been removed with a high-speed router in preparation for replacement of the repair details. An exploded view of the edge repair sequence is shown in figure 50.

The materials used in the repair matched those used in the initial part. The outer skin plug, internal patch plate, and inner skin patch were 0.025-in. thick 7075-T6 clad. A doubler strip was used at the edge to match edge buildup left on the original part by chem-milling. The details are shown in figure 51.

The original part was bonded with FM47 adhesive. The core was 2-07P 5052 aluminum. A slightly denser nonperforated core, 3-15, was substituted for the repair. AF127-3 was used for the film repair adhesive. The core splicing adhesive used was Thermofoam 3050-250.

The sheet metal details were prepared for bonding using phosphoric acid anodize tanks. The bare metal on the part's inner skin was prepared by hand anodizing. Polyester tape was used to mask the adjacent skin and core areas to prevent contamination from the acid. The interior bond surface on the exterior skin, coated with the original FM47 adhesive, was lightly abraded. This surface and the adjacent edges of core were then wiped with methylketone (MEK). The replacement core detail was cleaned with trichloroethylene.

The details were then assembled for bonding. The entire assembly was vacuum bagged and cured in a single stage in an oven for 2 hours at 200° F. After cure, the repaired component was nondestructively inspected. The quality of the repair was satisfactory. The repair after bonding is shown in figure 52; the component after painting is shown in figure 53.

3.4 T-38 HORIZONTAL STABILATOR

The T-38 horizontal stabilator is shown in figure 54. The component was obtained from Kelly Air Force Base.

An initial nondestructive inspection of the part revealed no significant damage. The simulated-type damage selected for repair was crushing of the trailing edge. The trailing-edge closeout consists of the skins laminated in a metal-to-metal bond at the tip.

The stabilator with the damaged area removed and with the repair details is shown in figure 55. A sketch showing the repair cross section is given in figure 56. Nonflush patch plates were used for the repair. The surface of the replacement core was machined to be flush with the component outer skin surface.

The skin for the stabilator is 7075-T6 and tapers from 0.036 in. at the tip to 0.096 in. at the root. The core is 2-07P 5052 aluminum. The original adhesive was FM47 manufactured by Bloomingdale.

The patch plates were fabricated from 0.040 7075-T6 aluminum. The replacement core was 3-15 nonperforated 5052 aluminum. The adhesive film used was AF127-3. Thermofoam 3Q50-250 was used as the core splice adhesive.

The bonding surfaces of the skin patches and those on the stabilator were prepared for bonding using phosphoric acid hand anodizing. Anodizing of the patch plates is shown in figure 57. The replacement core was cleaned with trichloroethylene.

Following bond surface preparation, the details were assembled and the part vacuum bagged for cure. The cure was in an oven for 2 hours at 200° F. A closeup of the repair after bonding is shown in figure 58; the total finished component is shown in figure 59.

After curing, the part was inspected using water coupled ultrasonic through transmission. The quality of the repair was satisfactory.

3.5 F-111 TITANIUM FUSELAGE PANEL

The fuselage panel was received in a shipment of damaged parts from Nellis Air Force Base. A photo of the several parts received is given in figure 60. The titanium panel is the three-bay haunch-shaped panel at the bottom.

The panel had been scrapped because of being damaged beyond repairable limits. Damage included extensive delamination, core deterioration, and torn and twisted skin. In order to keep the repair effort within reasonable limits, it was decided to repair only the larger panel bay. This was cut from the rest of the panel for handling convenience.

Repair required replacement of a major part of the inner skin, core, and edge closeout details. It required only minor rework to the formed and chem-milled outer skin.

The panel internal skin and edge members were quite thin. The skin thickness was 0.012 in., and the edge details were 0.008 in. The material was 6Al-6V-2Sn titanium alloy. The core was 4.5- and 6.1-lb/ft³ 5052 aluminum.

Where possible, the damaged metal details on the panel were removed, cleaned, and straightened for reuse. The damaged core was replaced with new core. The replacement core details were cut to maintain the same splice lines as in the original part. The panel with the damaged area removed and with repair details is shown in figure 61.

After fabrication and straightening, the details were assembled in a prefitting operation. The parts were then disassembled and cleaned for bonding. The sheet metal details and the bonding surfaces on the panel were prepared with PasaJell 107. The procedure for this was the same as that used earlier for the small area repair specimens. This was described in table 5. Polyester tape was used on the panel during cleaning to mask areas that might become contaminated by the acid.

The core details were vapor degreased in a trichloroethylene tank. Cleaning of the core edges in the panel was with MEK.

After the surfaces were prepared for bonding, they were primed with BR400 primer. High temperature FM400 was used as the adhesive film. The core splices were made with Thermofoam 3050-350. The cure was accomplished using 23-in. Hg vacuum pressure. The cure temperature was 350°F for 1 hour.

Nondestructive inspection of the part after bonding was accomplished using water coupled through transmission ultrasonics. The repair quality was satisfactory. The completed part is shown in figure 62.

3.6 C5-A AILERON TRAILING-EDGE PANEL

This component was received from Dover Air Force Base. It is shown in the as-received condition in figure 63. The face was delaminated and corroded. When this was removed, it was evident that the panel had been repaired previously. Sections of the core surface had been potted. A large section of core on one end had been replaced. This is shown in figure 64.

A breakdown sketch of the component is shown in figure 65. Work consisted of repairing the core and replacing the skin and the longitudinal and side doublers. The skin and doublers were 0.025 and 0.020 2024-T3 aluminum, respectively. The core was 3-15N 5052 Al.

Small damaged areas in the core were repaired with Corfil 615 potting compound. The sheet metal details were cut to size. The center of the skin was then formed to the wrap-around tip radius.

Surface preparation of the sheet metal details for bonding was by phosphoric acid hand anodizing. The skin provided a large area for demonstrating the anodizing procedure. The procedure in progress is shown in figure 66. The lower part of the skin is being anodized. The anode terminal of the rectifier is attached to the skin. The cathode is attached to the stainless steel screen.

The bond areas on the part had a coating of the original adhesive. This was lightly sanded and wiped with MEK. The details were then primed and the part assembled for bonding. The primer was EC3921, and the adhesive was AF127-3. The part details are shown ready for assembly in figure 67.

The assembly was envelope bagged for cure using standard bonding procedures. Cure was accomplished in an autoclave at 200°F for 2 hours. The pressure was 35 psi. The part after cure is shown in figure 68. The assembly had collapsed due to the lateral pressure component on the core. The failure emphasized that adequate support fixtures are required for curing this type of part.

It was decided to rebuild the part. New details were fabricated. Surface preparation for bonding in this case was done in the production cleaning tanks. The sheet metal parts and the spar extrusion were phosphoric acid anodized. The core was vapor degreased with trichloroethylene.

The assembly was bonded in two stages. The first stage consisted of bonding the core block to the spar and end ribs. The core surface was then final machined using the spar and end rib surfaces for indexing. The doublers and wraparound skin were bonded in the second stage.

In both bond stages, the edges of the core were fully supported by form blocks fixed to the tool base to prevent lateral movement. The downward pressure on the core was evenly distributed by use of a caul plate. The tooling concept is illustrated by sketch in figure 69.

The cure for the two bonding stages was for 2 hours at 200°F and 23-in. Hg vacuum pressure. After curing, the repaired area was inspected using water coupled through transmission ultrasonics. The quality of the finished part was satisfactory. It is shown in figure 70.

3.7 A-6 VERTICAL FIN PANEL

A damaged A-6 vertical fin assembly was received from the Navy at Norfolk, Virginia. The fin was quite extensively damaged on the leading edge, whereas the damage was less toward the aft section.

A view of the right side of the fin is shown in figure 71. A decision was made to repair the *midside panel shown with the large diagonal gash*. The panel was removed from the fin. A closeup of the damage on the exterior face is shown in figure 72. The panel also had considerable denting in the gash area. The internal surface of the panel is shown in figure 73.

The surface of the panel was curved in the fore and aft direction. Because of this, fabrication of the BAJ was required to achieve proper contour during bonding. The contour for the BAJ was obtained by filling and smoothing the damaged panel surface. Filling was done with Corfil 615. The restored panel surface is shown in figure 74.

After the cosmetic treatment of the panel surface, a metal contour sheet was attached to the panel with double-backed tape. This is shown in figure 75. This sheet was used as a base for forming the fiberglass laminate BAJ. Parting film, followed by a multilayered prepreg laminate, was layed up on the metal sheet surface. The entire assembly was then vacuum bagged. The assembly is shown at a point where it is ready for closure and sealing of the vacuum bag in figure 76. The vacuum bagging material included the following:

1. Perforated release film (over the laminate)
2. 1500 fiberglass tooling mat (resin bleeder)
3. Osnaburg cloth (air bleeder)
4. Nylon bag film
5. Vacuum seal tape
6. Thermocouple wires
7. Vacuum probes

The laminate was precured for 2 hours at 200°F. It was then removed from the panel and postcured for 4 hours at 350°F.

Cross sections of the panel and the repair design are shown in figure 77. A trapezoidal area was cut from the panel to remove the damage. A sheet of mylar film was placed over the cutout area and marked. This was used as a template for cutting the core outline and edge recesses. The template is shown in figure 78. Machining with the high-speed core surfacing machine is shown in figure 79.

The skin patch material thicknesses and the core plug density were selected to match those of the panel. The skin repair material was 2024-T3 bare aluminum. The core was 3-10N 5052 aluminum.

The repair details are shown ready for assembly in figure 80. Surface preparation for bonding consisted of *hand phosphoric acid anodizing the sheet details and the surface of the panel interior skin that received the inner bonded patch*. The panel bond surfaces with

residual adhesive were lightly abraded and wiped with MEK. The replacement core detail was cleaned with trichloroethylene.

The film adhesive used was AF127-3 with EC3921 primer. The adhesive used for splicing the core was Thermofoam 3050-250.

The layup for bonding was quite similar to that previously described in section 3.2 for the C-141 APU access panel. Parting film and then the fiberglass BAJ were secured to the exterior panel surface over the repair area. The layup sequence then proceeded with the detail parts and interleaving adhesive.

The sequence can be noted from figure 77 view B-B starting from the top with the flush skin plug, a layer of adhesive film, the filler doublers, covering adhesive strips, and the splice doublers. The core splice adhesive was then installed, and the adhesive strips were placed over the splice doublers. The core was then slid into place; the adhesive film and finally the covering internal splice plate were added. The splice plate was secured in position with polyester tape.

The assembly was envelope vacuum bagged. The cure was for 2 hours at 200°F under 23-in. Hg vacuum pressure.

Nondestructive inspection (NDI) after the cure indicated that the repair was satisfactory. The exterior and interior repair surfaces are shown in figures 81 and 82, respectively. The finished panel after painting is shown in figure 83.

4.0 REPAIR HANDBOOK PREPARATION

A considerable amount of the effort expended in Phase III was in preparation of drafts of the handbook sections. The draft completion status of the various sections is as follows:

Section	Title	Completion status
1.0	Introduction	Complete
2.0	Damage Assessment	Complete
3.0	Repair Method Selection	Complete
4.0	Materials and Processes	Complete
5.0	Surface Preparation	Complete
6.0	Small Area Repairs	Secs. 6.0 through 6.6 Complete
7.0	Large Repair Methods	No
8.0	Equipment and Facilities	No
9.0	Tooling	No
10.0	Nondestructive Inspection	Complete

The completed draft sections have been submitted to the Air Force program monitors for review.

5.0 PHASE IV FOLLOW-ON PLANS

Work scheduled for Phase IV consists primarily of demonstrating repair procedures on an F-111 outboard spoiler and writing the handbook sections. The spoiler is shown in figure 84. The damage will be to the trailing edge starting in line with the outboard hinge fitting and extending inboard approximately 2 ft. It will extend in from the trailing edge to about 40% of the chord.

The repaired spoiler will be tested with a simulated air load similar to tests conducted by General Dynamics. The condition to be used will be with the spoiler deflected 20° . Loading will be to 150% design limit load (DLL). Tip deflections will be measured. Movie and still photo coverage are planned for the NDI, repair, and test phases.

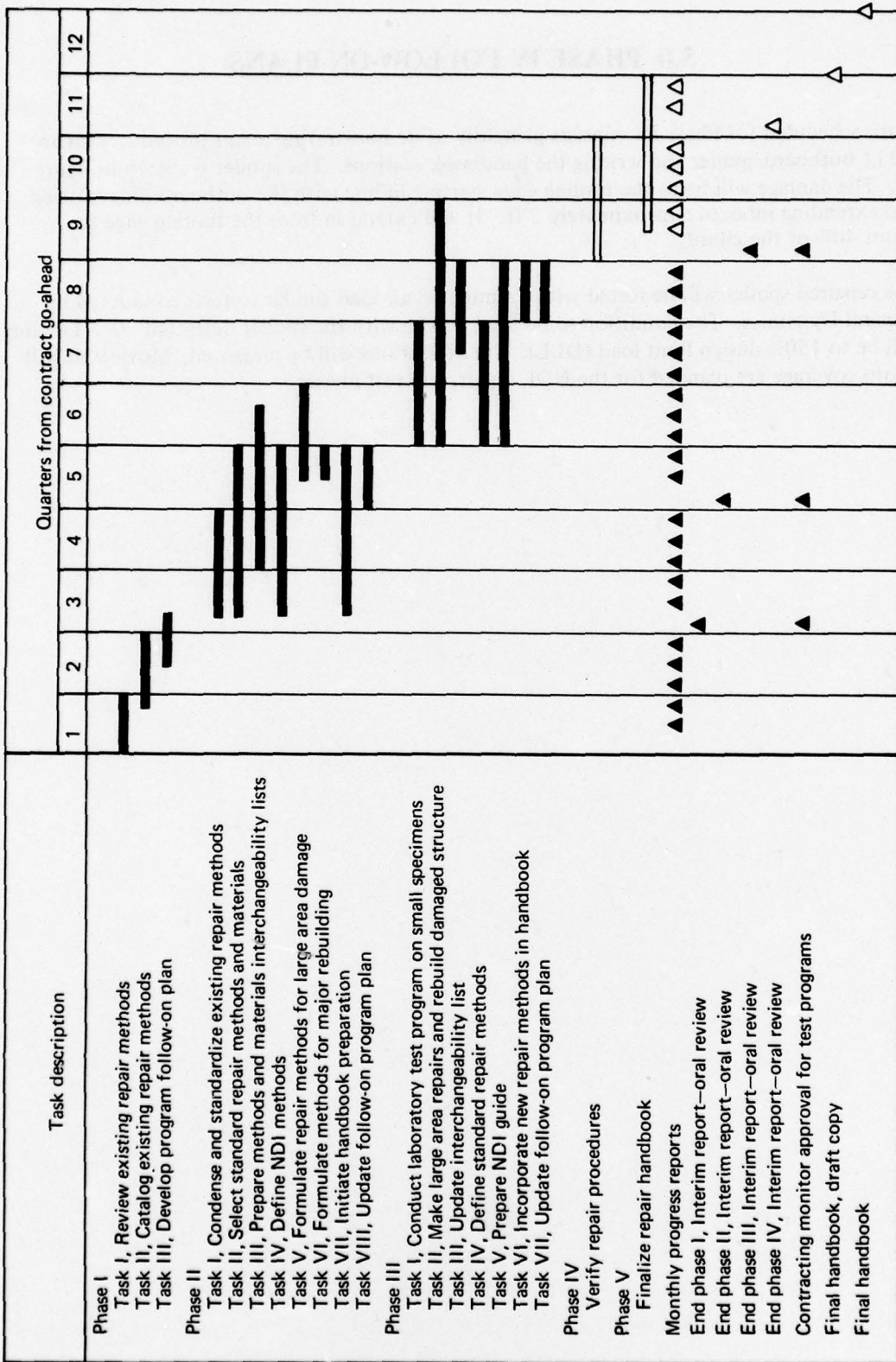

Figure 1.—Program Schedule

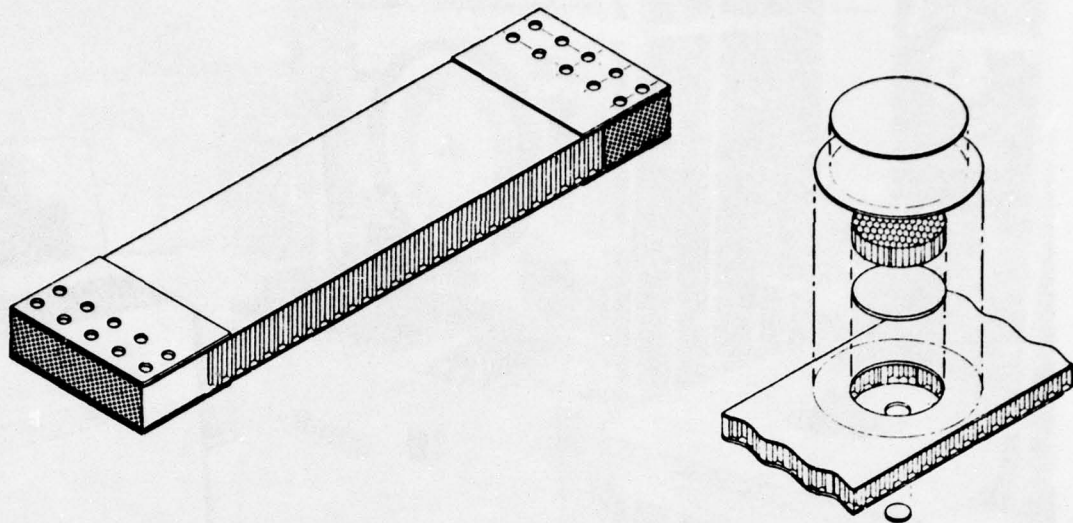
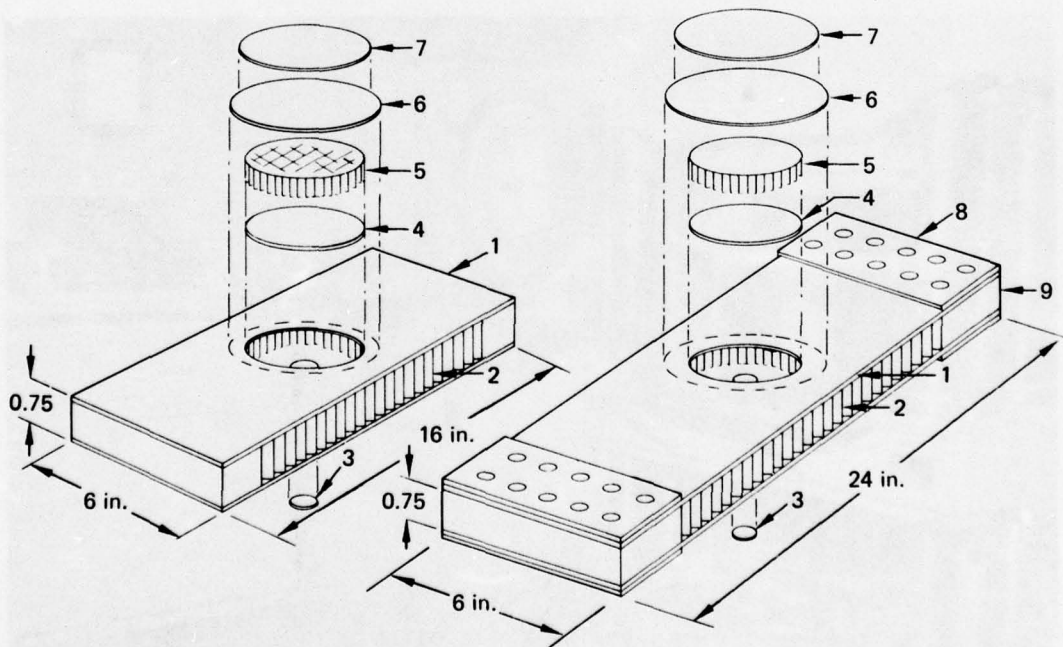

Figure 2.—Configuration of the Small Area Repair Test Specimens



Note: See Table 2.

Figure 3.—Exploded View of the Small Area Repair Test Specimens

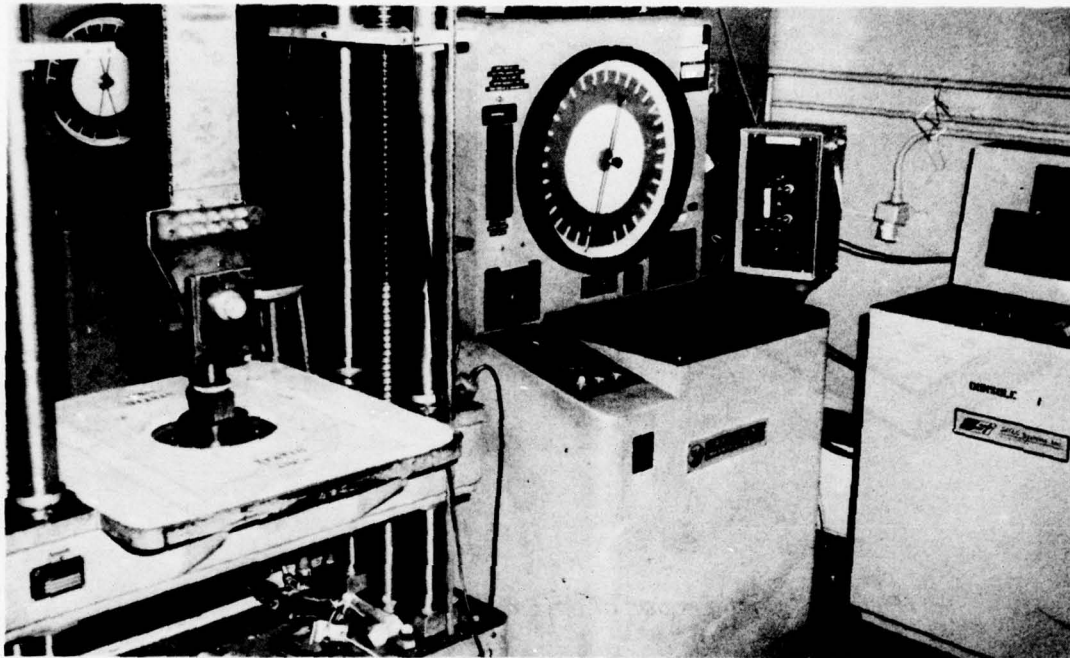

Figure 4.—Small Area Repair Control Specimen Mounted for Tensile Testing

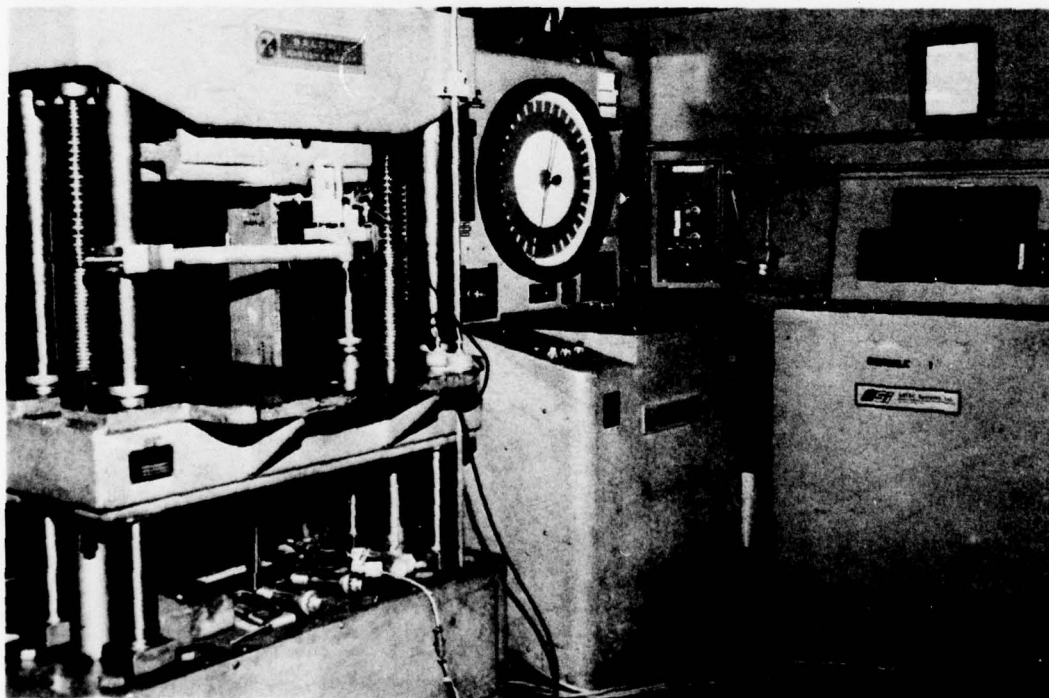

Figure 5.—Small Area Repair Control Specimen Mounted for Compression Testing

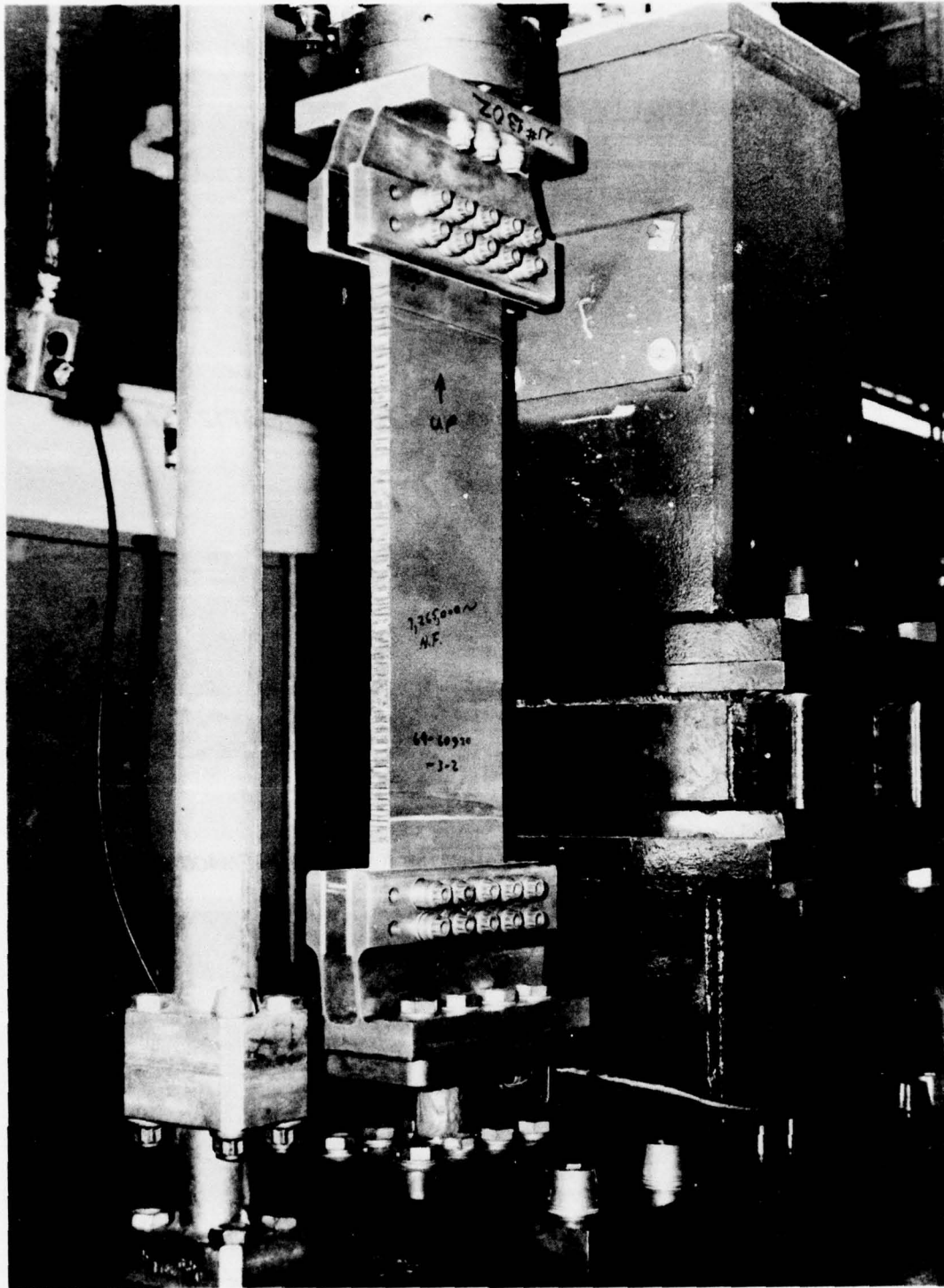

Figure 6.—Small Area Repair Control Specimen Mounted for Fatigue Testing

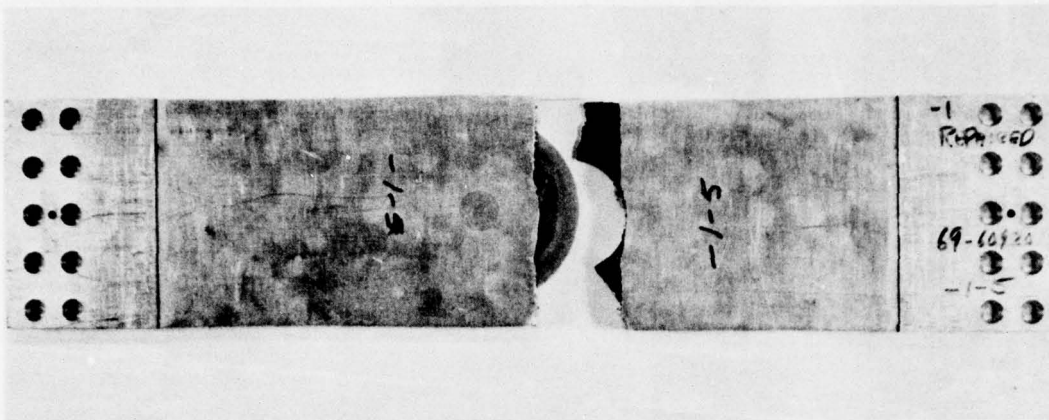

Figure 7.—Repaired Aluminum Specimen After Tensile Test—AF127-3 Adhesive

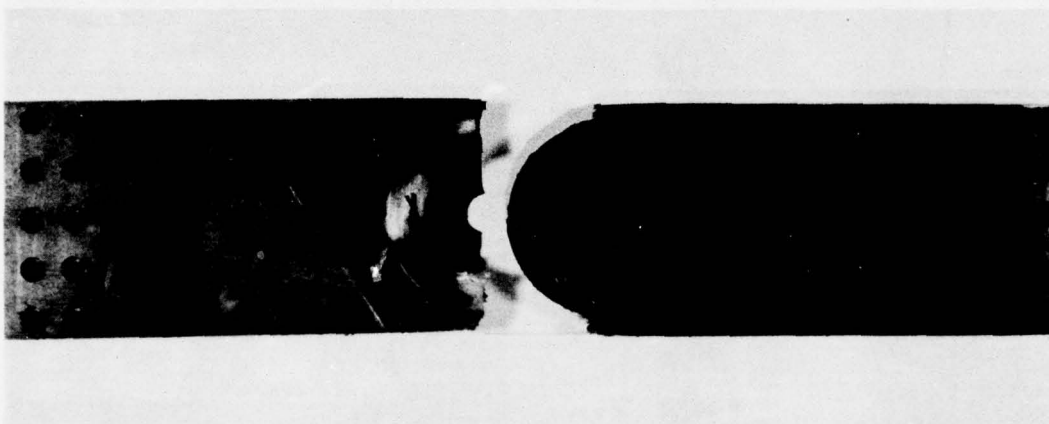

Figure 8.—Repaired Titanium Specimen After Tensile Test—FM400 Adhesive



Figure 9.—Titanium Compression Control Specimen Showing Edge Crippling

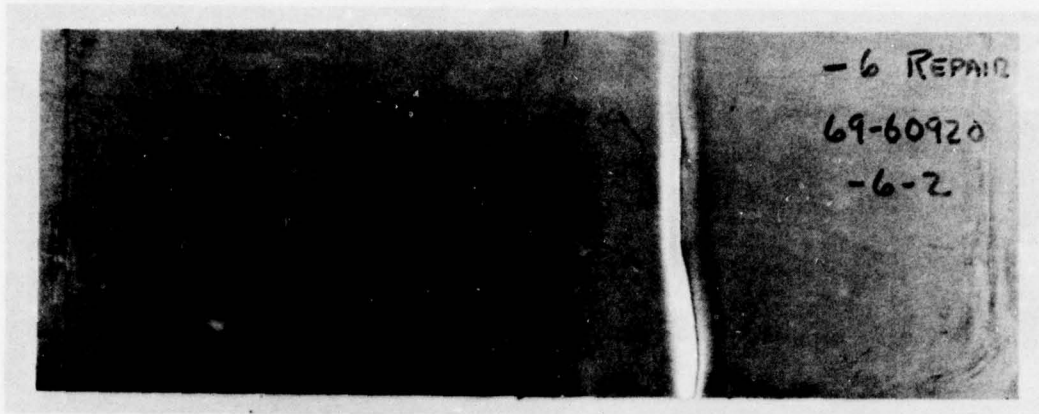

Figure 10.—Titanium Compression Repair Specimen After Test

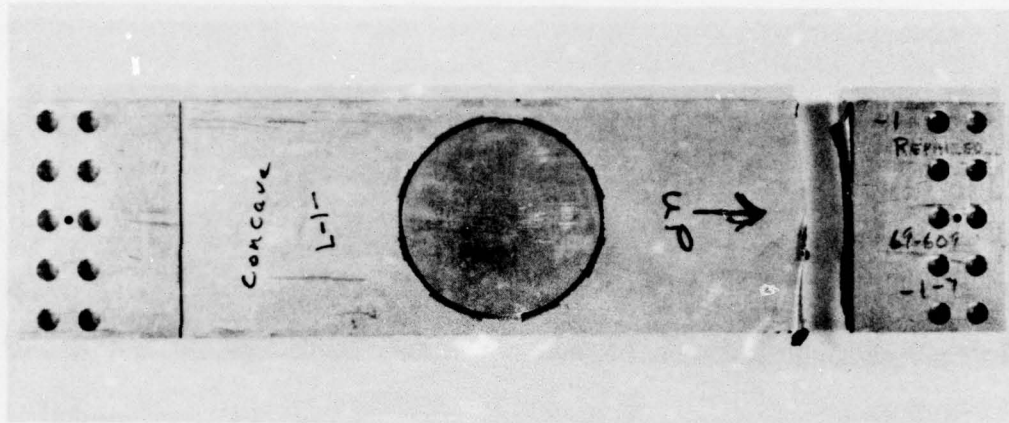

Figure 11.—Typical Fatigue Failure—Repaired Aluminum Specimen—AF127-3 Adhesive

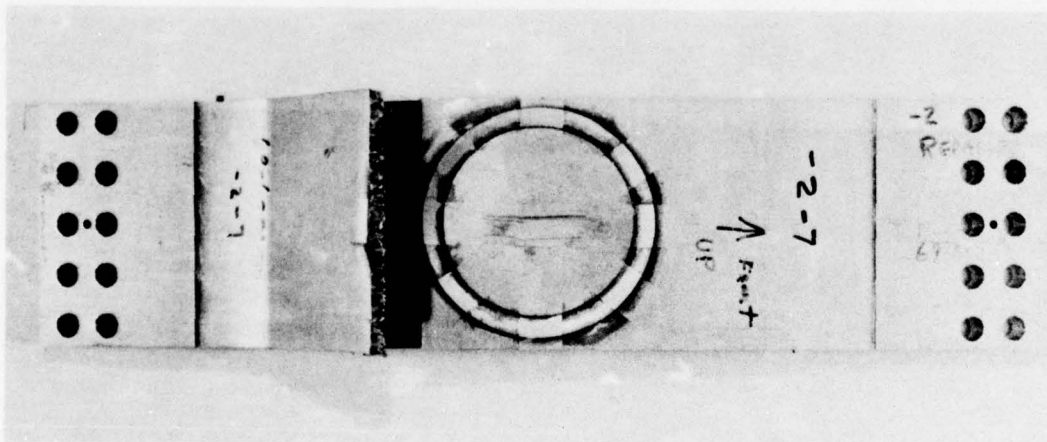

Figure 12.—Typical Fatigue Failure—Repaired Aluminum Specimen—AF130 Adhesive

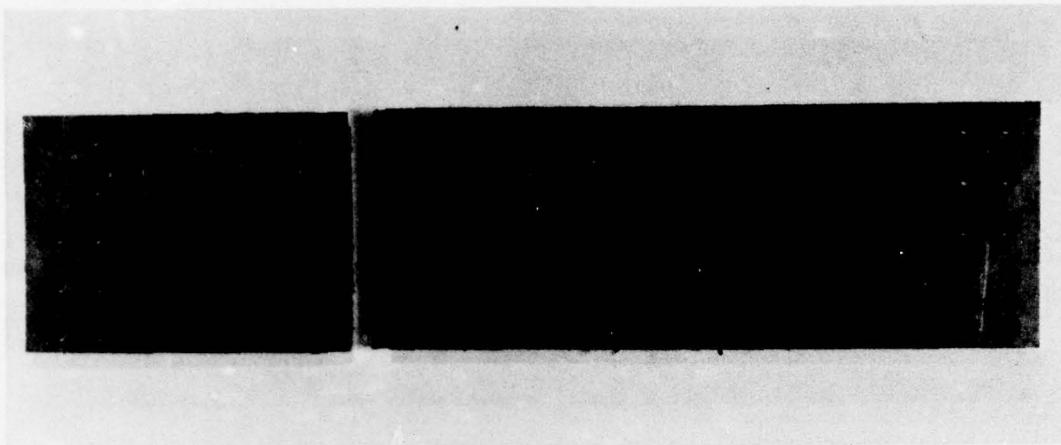

Figure 13.—Base Metal Failure—Repaired Titanium Fatigue Specimen

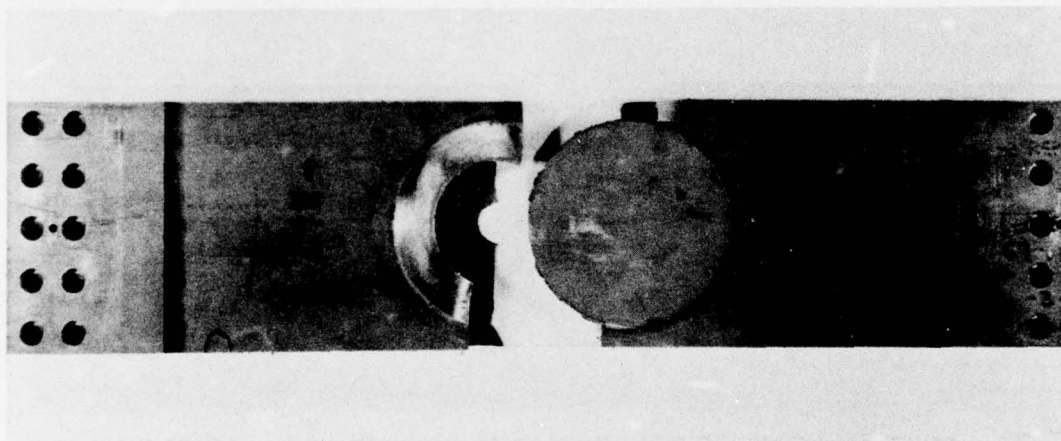

Figure 14.—Repair Area Failure—Titanium Fatigue Specimen (3-7)

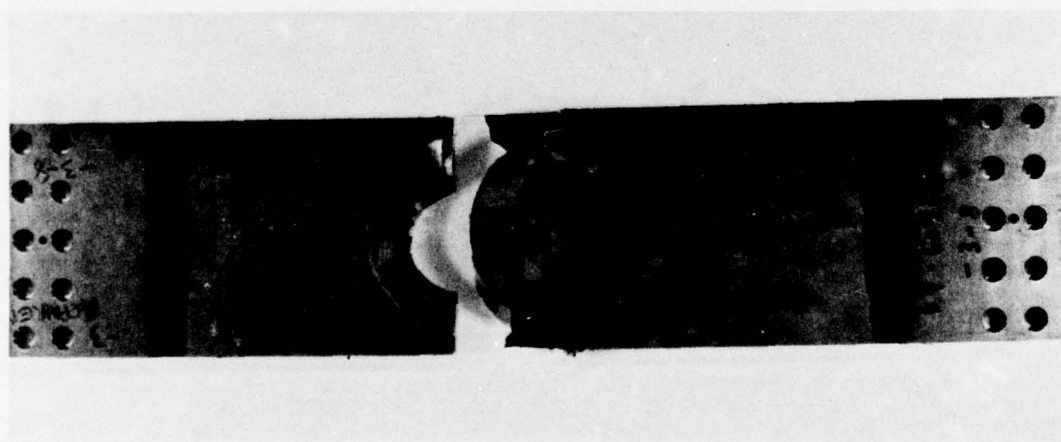

Figure 15.—Repair Area Failure—Titanium Fatigue Specimen (3-8)

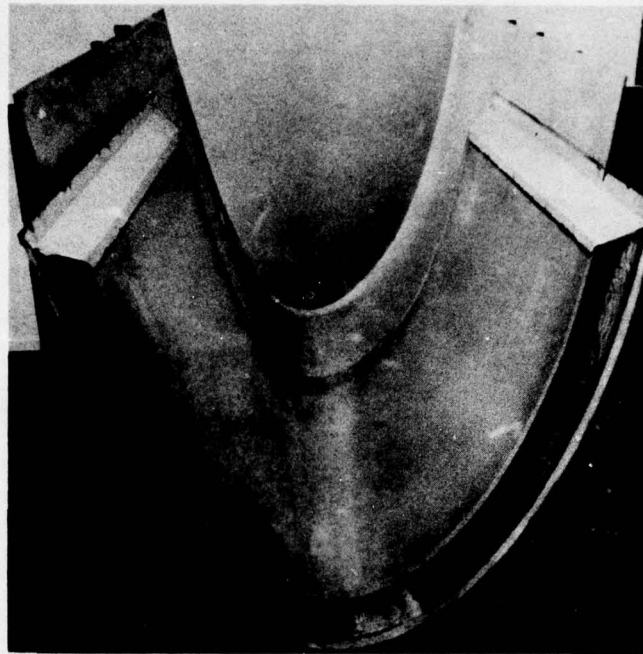

Figure 16.—Simulated C-141 Wing Leading Edge After Fabrication

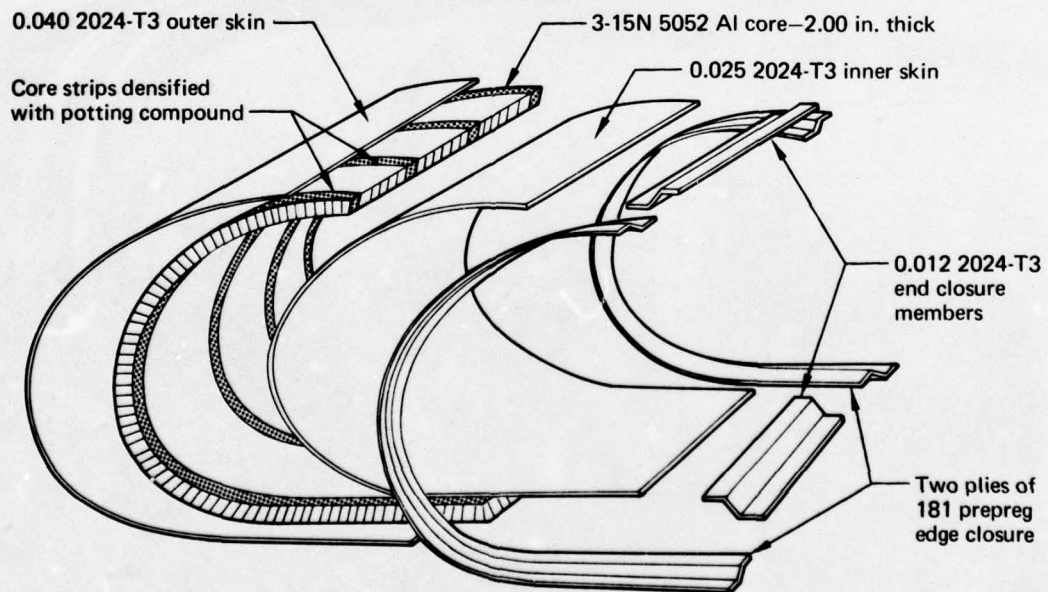

Figure 17.—Breakdown of the Simulated C-141 Wing Leading Edge Construction

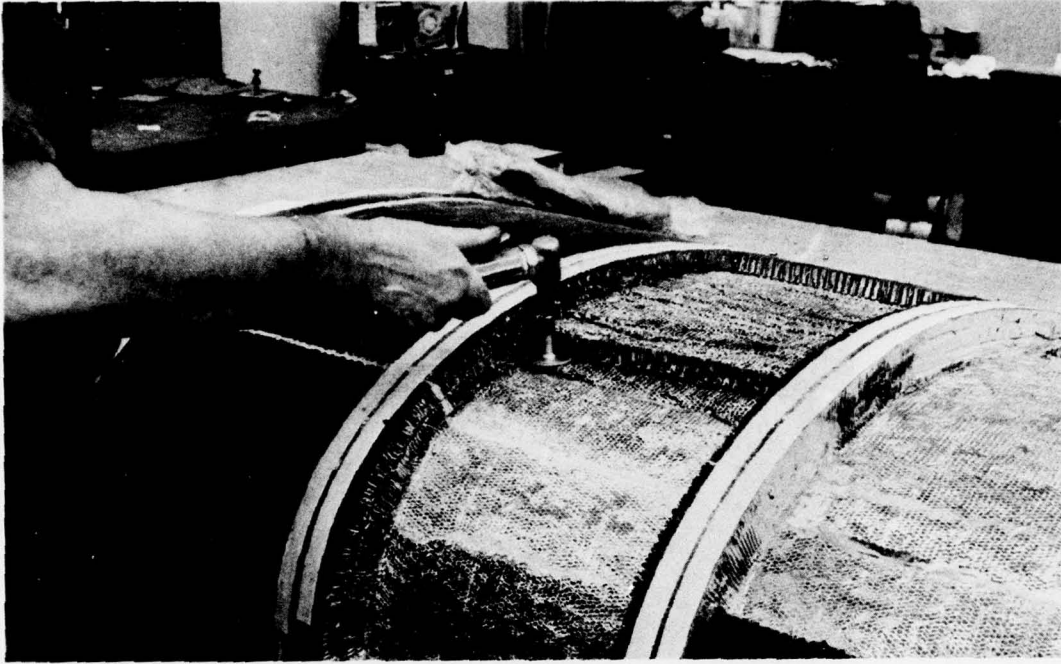

Figure 18.—Removing Core With the High Speed Cutter

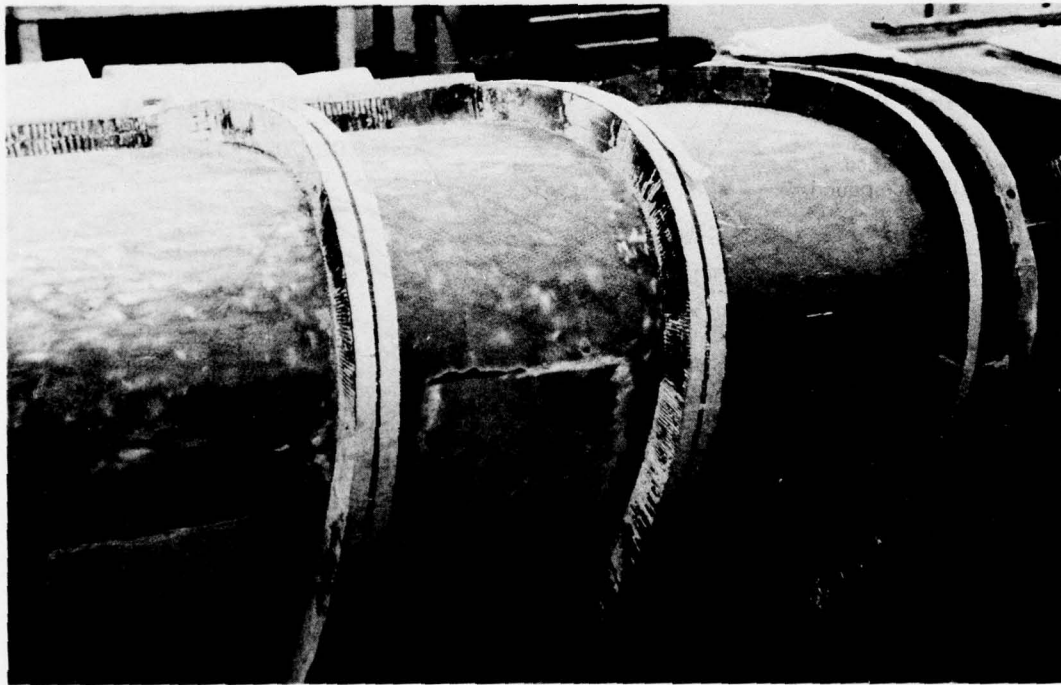

Figure 19.—Core Removed With Bare Metal Areas to Demonstrate Surface Preparation Techniques

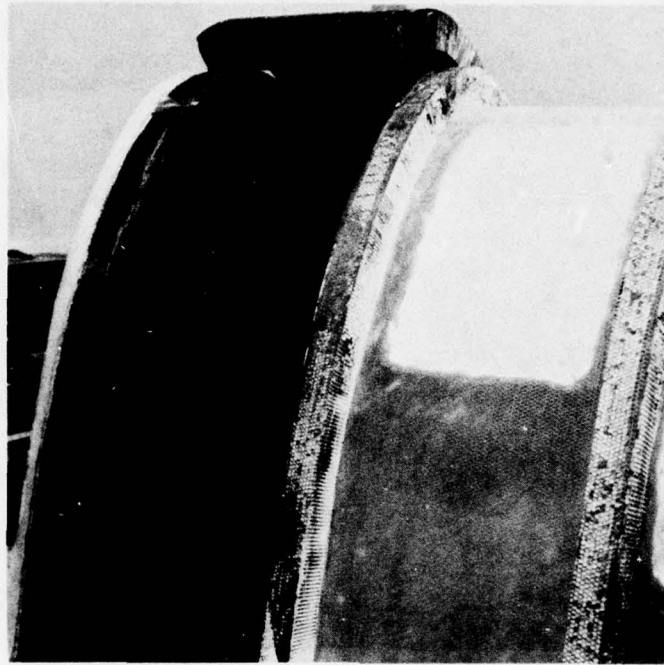

Figure 20.—Prefit of Replacement Honeycomb Core

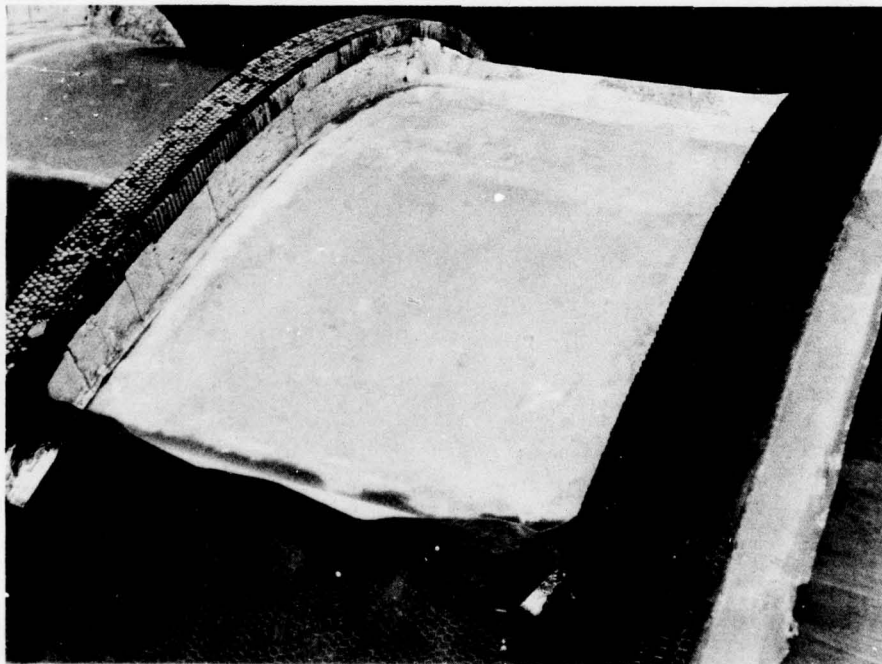

Figure 21.—Start of Hand Anodize Procedure—Phosphoric Acid Applied to Bare Metal Surface

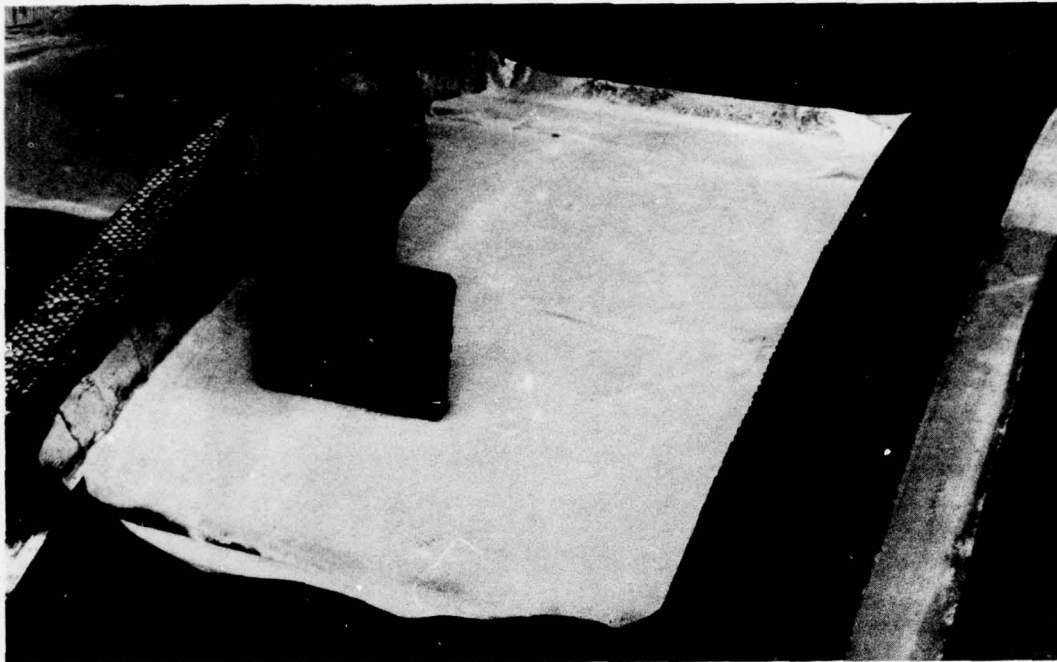

Figure 22.—Gauze Applied Over Acid Gel—Additional Gel Being Applied

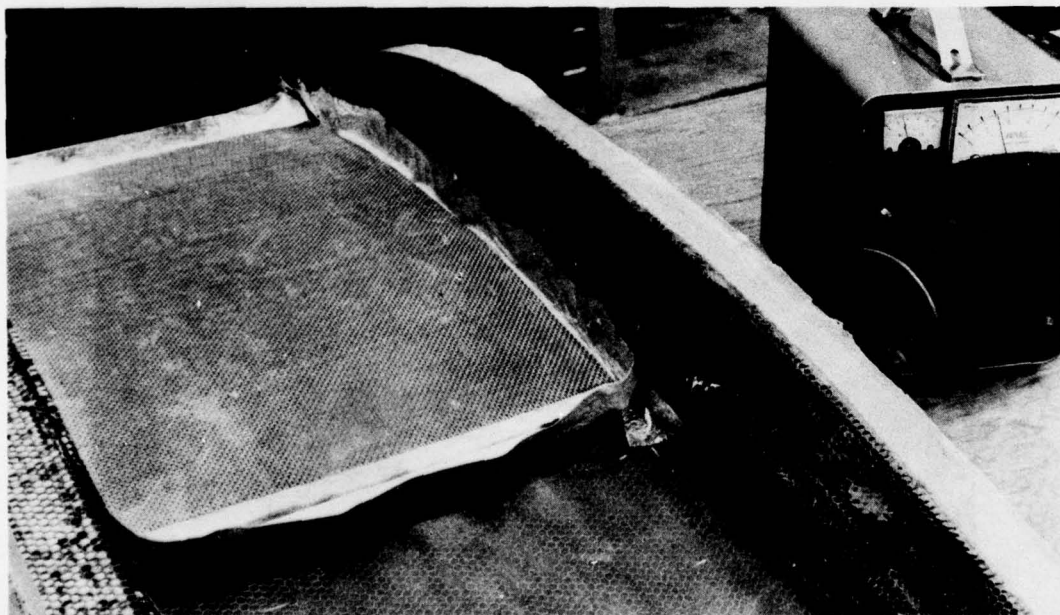

Figure 23.—Stainless Steel Screen in Place—Anodizing in Progress

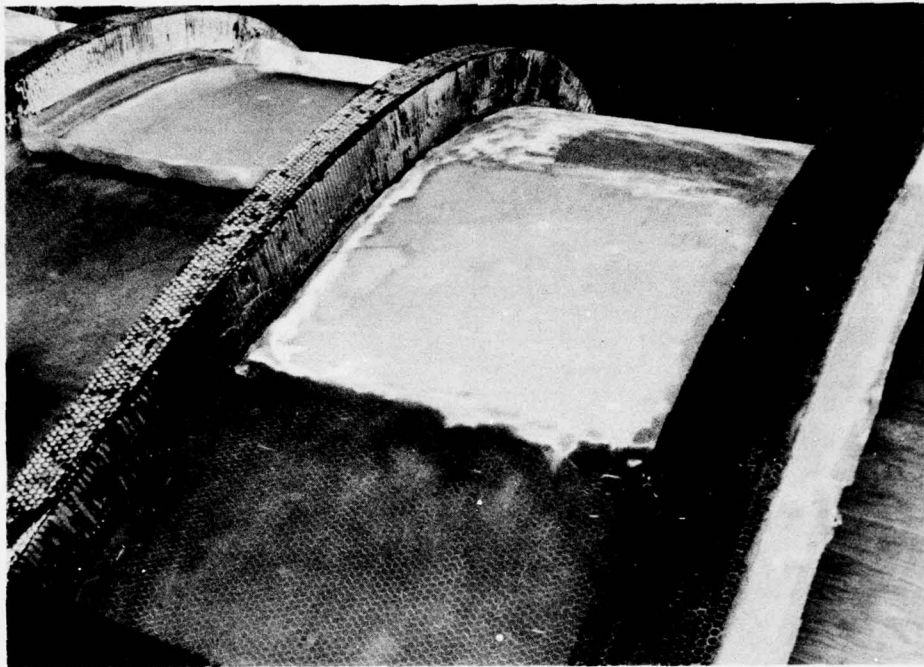

Figure 24.—Anodizing Complete—Surface Ready for Primer Application

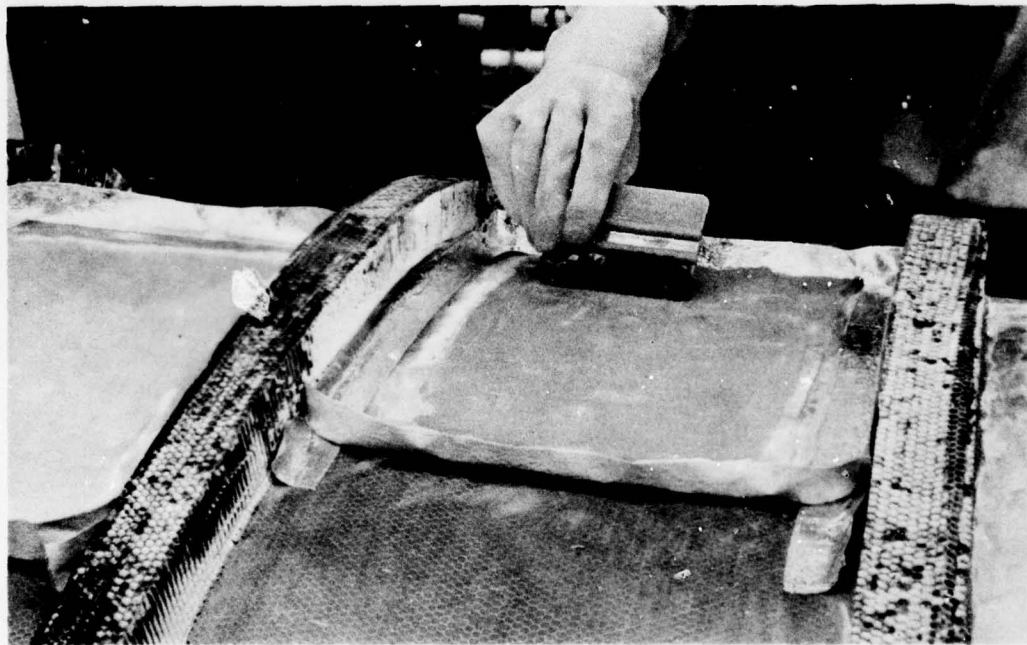

Figure 25.—Surface Preparation of the Second Bay With PasaJell 105

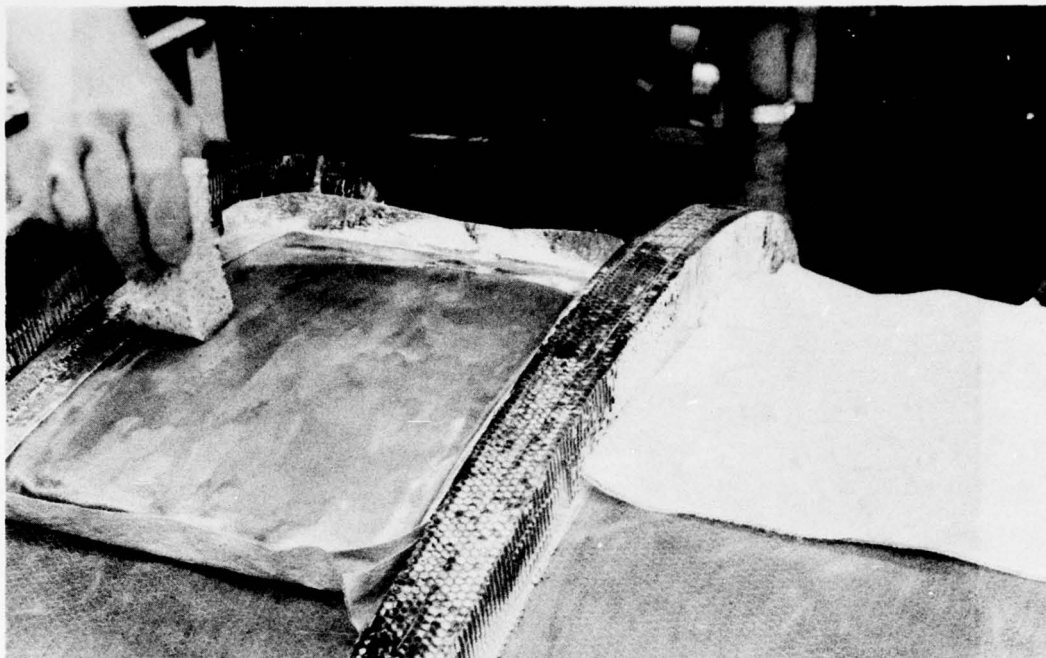

Figure 26.—Surface Preparation of the Third Bay With 2% Hydrofluoric Acid

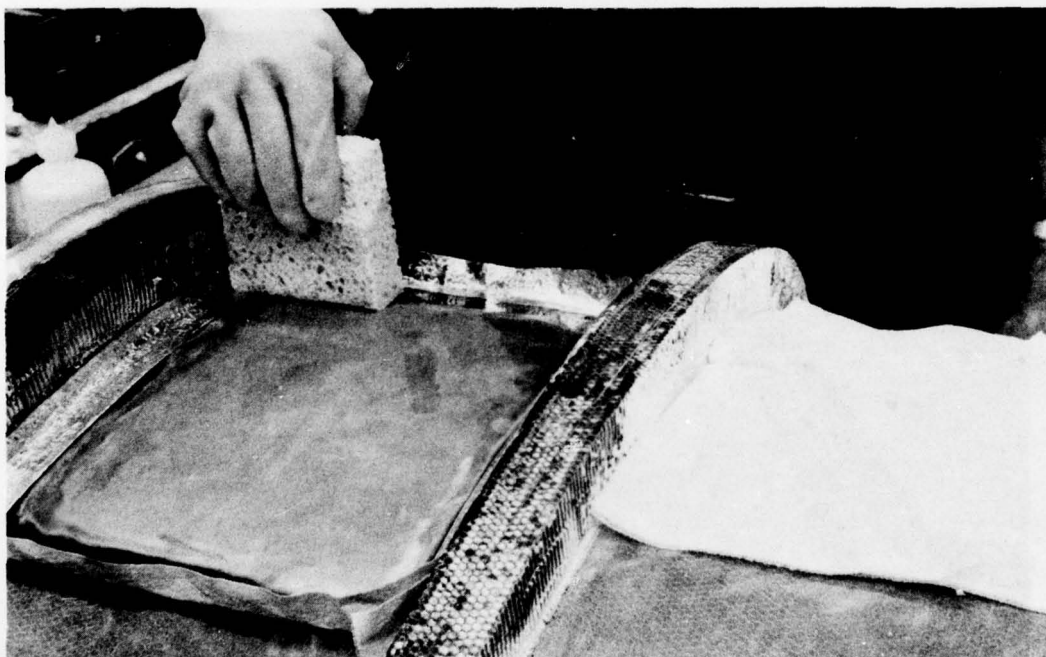

Figure 27.—Application of Alodine 1200 to the Third Bay Surface After Acid Treatment

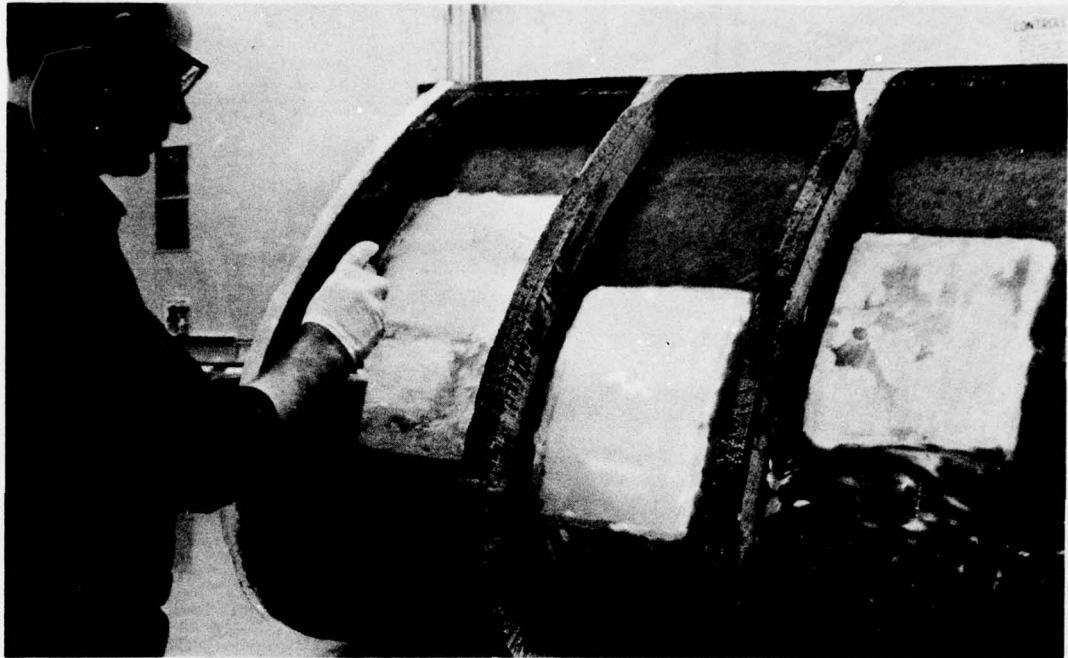

Figure 28.—Application of EC3921 Adhesive Primer Using a Preval Power Unit



Figure 29.—Application of the AF127-3 Adhesive Film

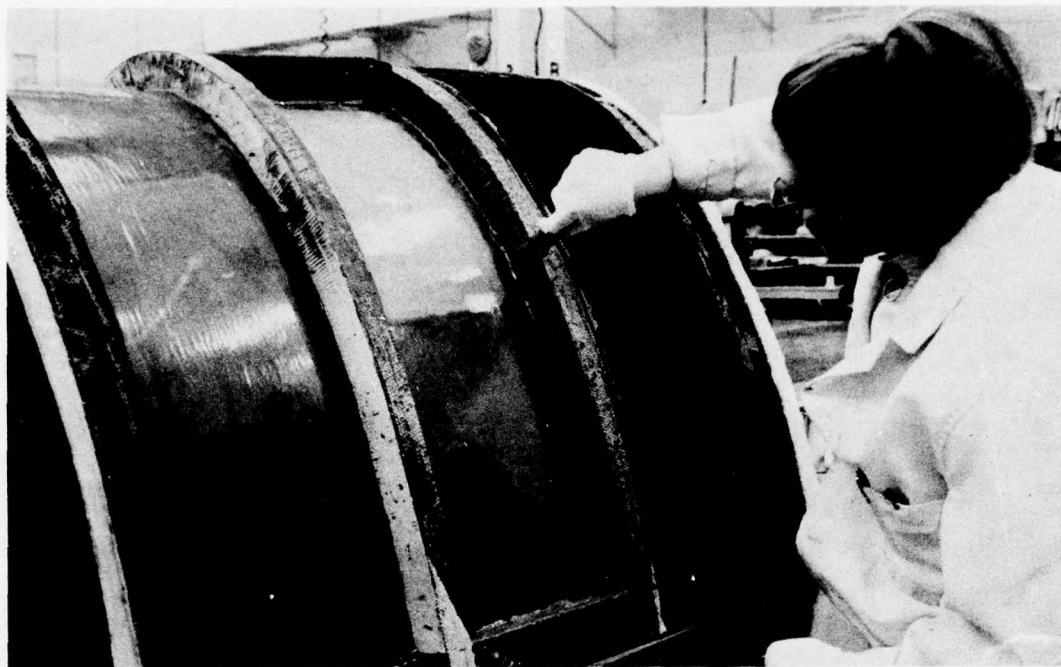

Figure 30.—Application of the Core Splicing Compound

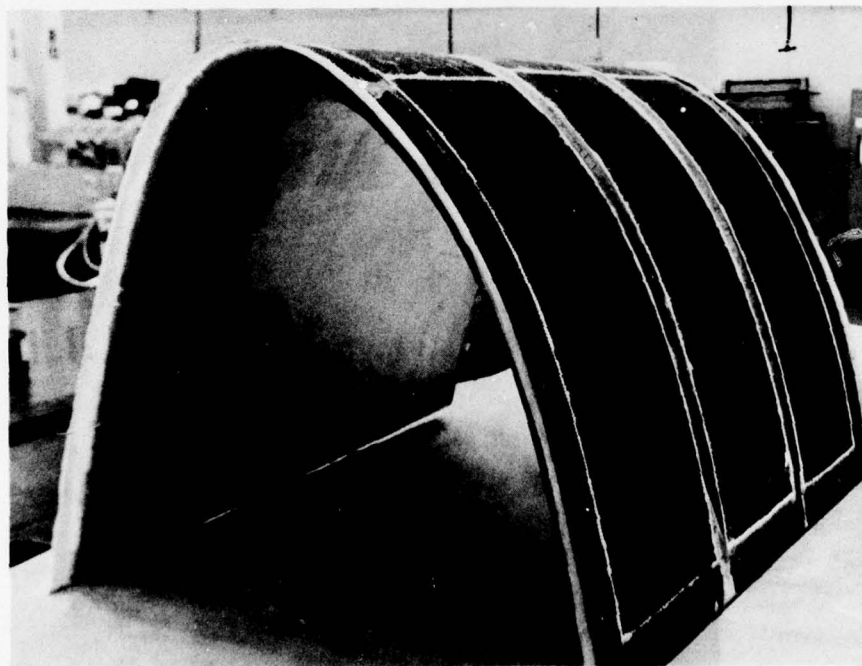

Figure 31.—Replacement Core Installed—Assembly Ready for First-Stage Cure

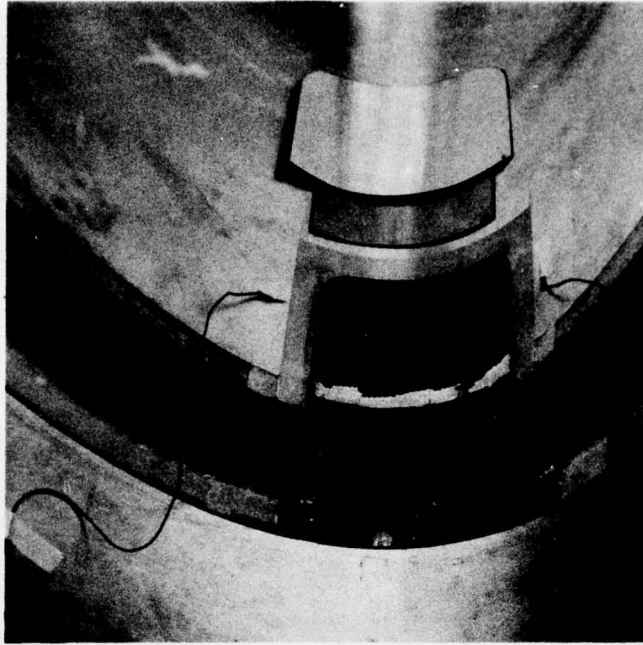

Figure 32.—Repaired C-141 Wing Leading Edge Ready for the First-Stage Cure

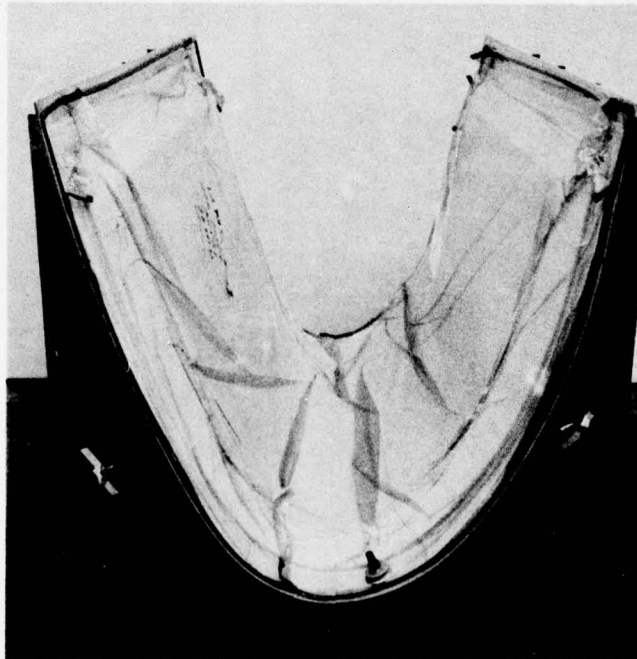

Figure 33.—Details for Repair of a Void in the Leading Edge Assembly

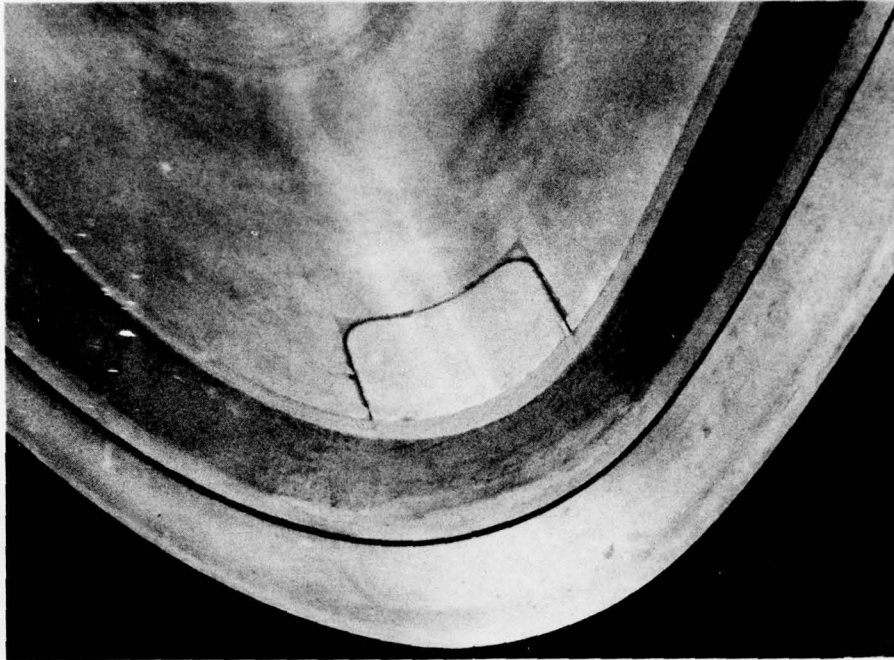

Figure 34.—Completed Repair of Void Area

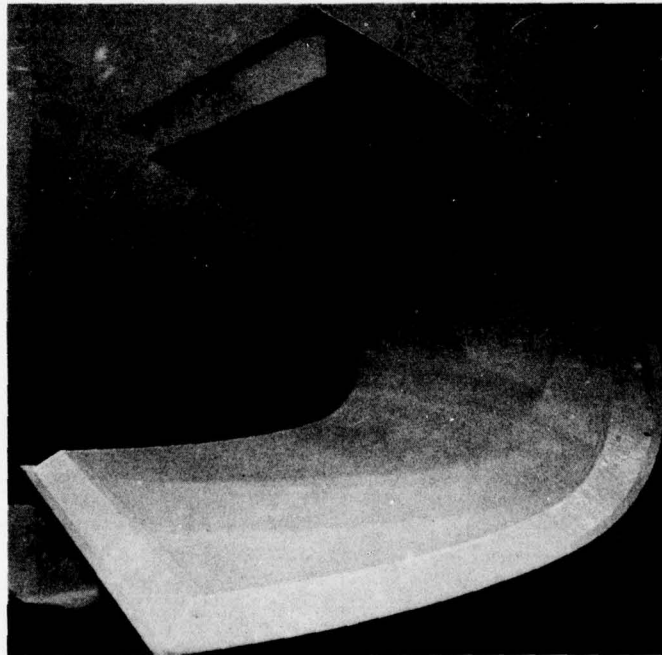

Figure 35.—C-141 Wing Leading Edge After Rebuild

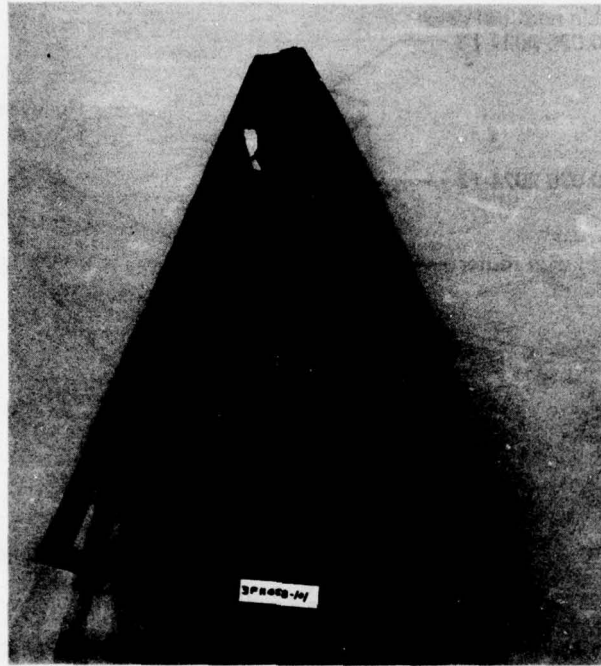

Figure 36.—C-141 APU Access Panel Received From Warner Robins ALC

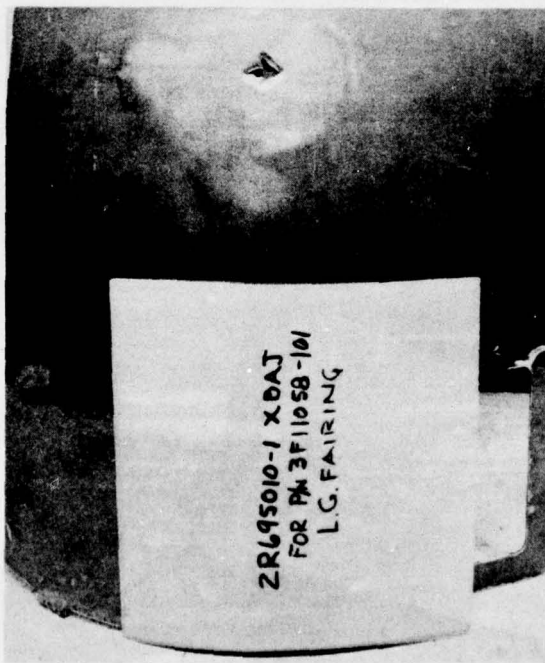

Figure 37.—Damaged Access Panel and Molded Fiberglass Bond Assembly Jig (BAJ)

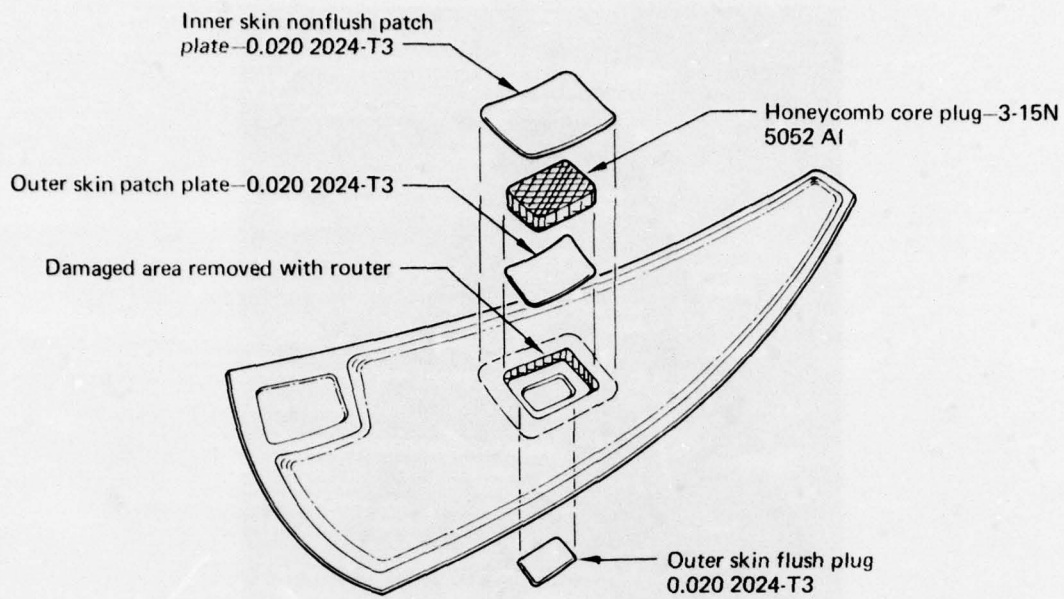

Figure 38.—Exploded View of Repair Details for the C-141 APU Access panel



Figure 39.—Damaged Removed and the Repair Details Shown

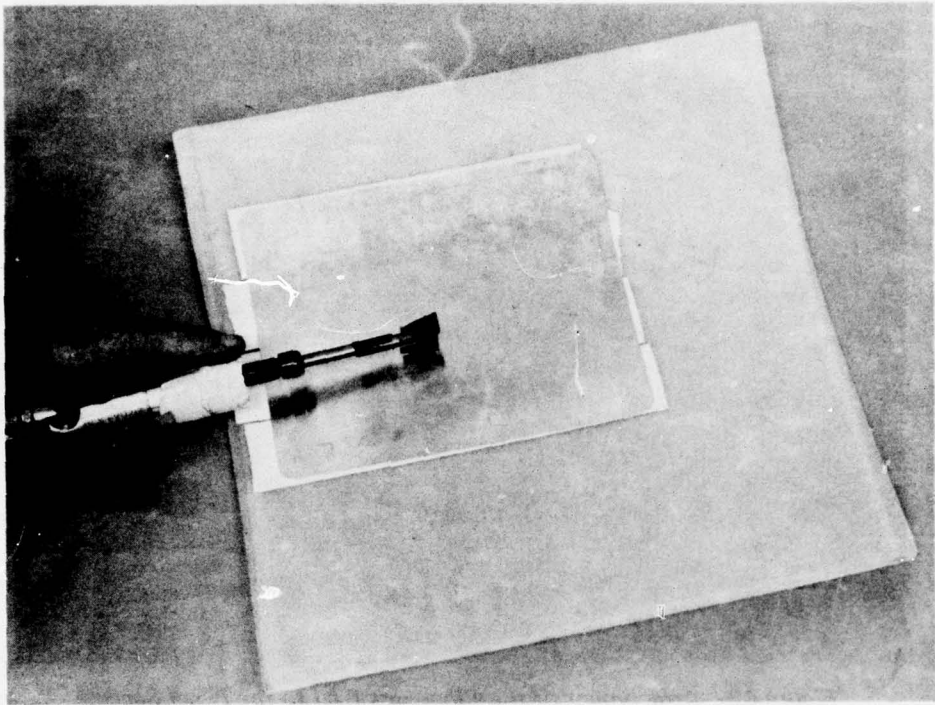

Figure 40.—Roto-Peening the Patch Plate to Proper Contour

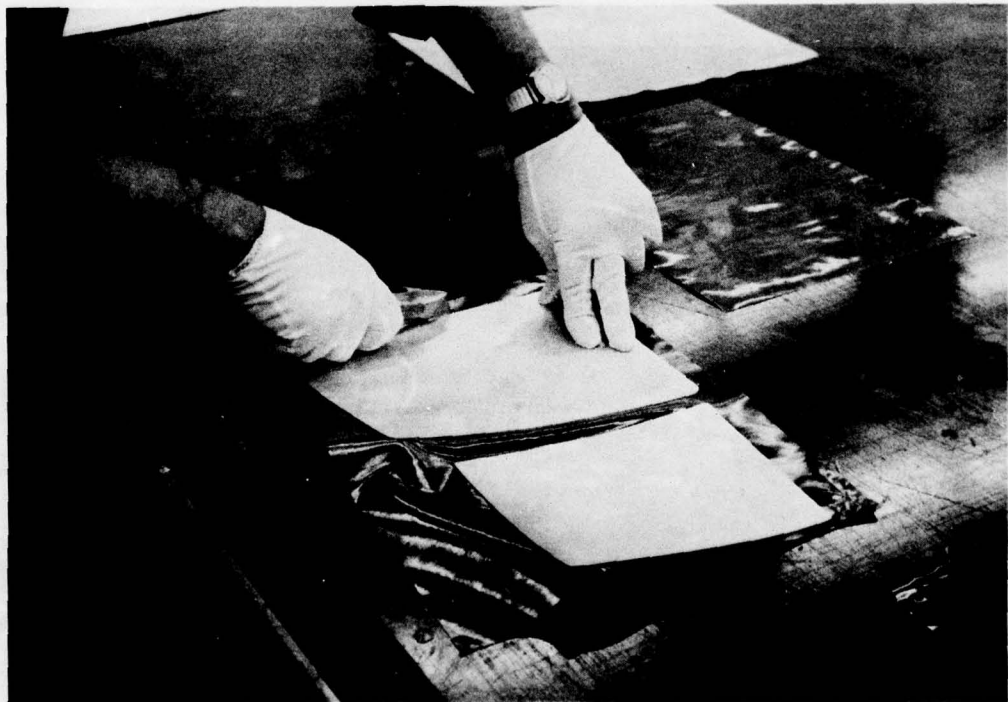

Figure 41.—Cutting the Adhesive Film to Size

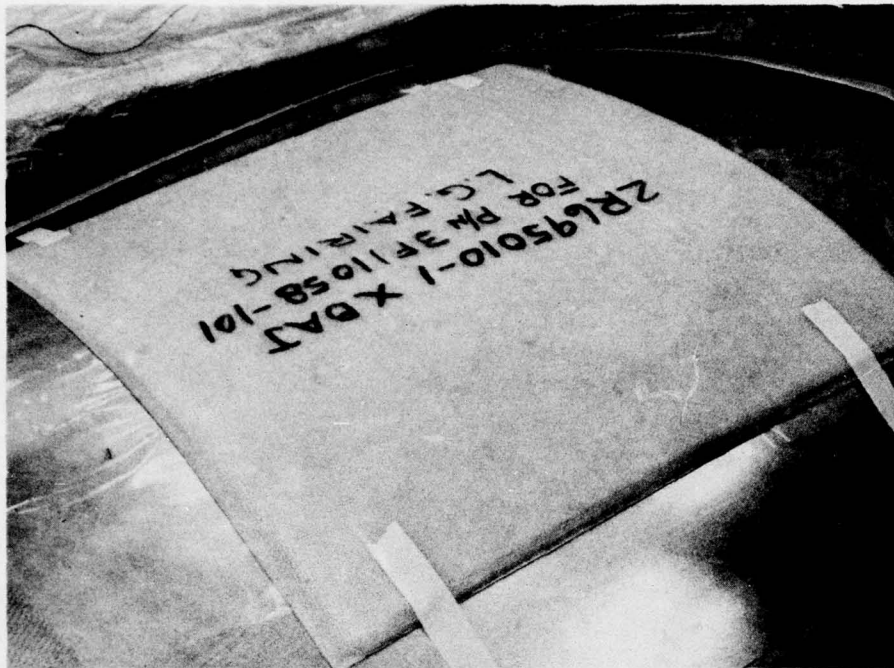

Figure 42.—Attachment of the Fiberglass BAJ to the Panel Surface



Figure 43.—Installation of the Core Splice Adhesive



Figure 44.—Positioning the Stainless Steel Screen for Anodizing the Metal Bond Surface

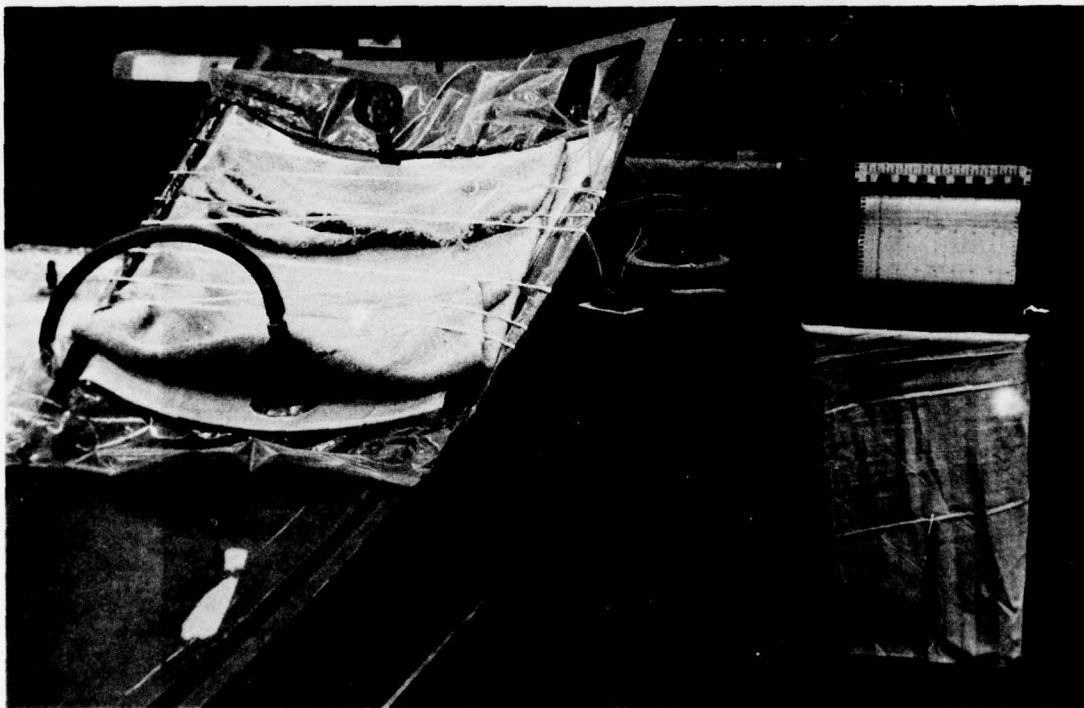

Figure 45.—C-141 APU Access Panel Repair—Cure in Progress

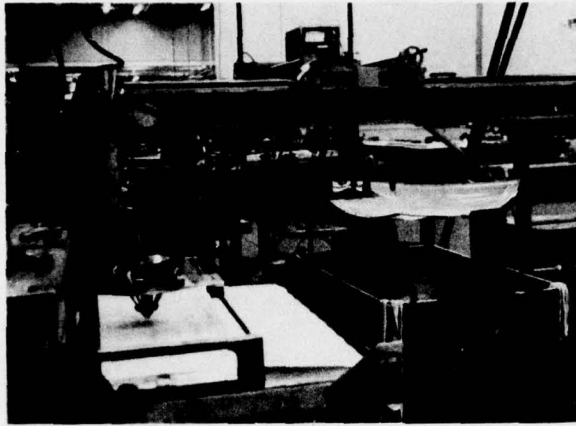

Figure 46.—Inspection of the Repaired C-141 APU Access Panel—Water Coupled Through Transmission Ultrasonics

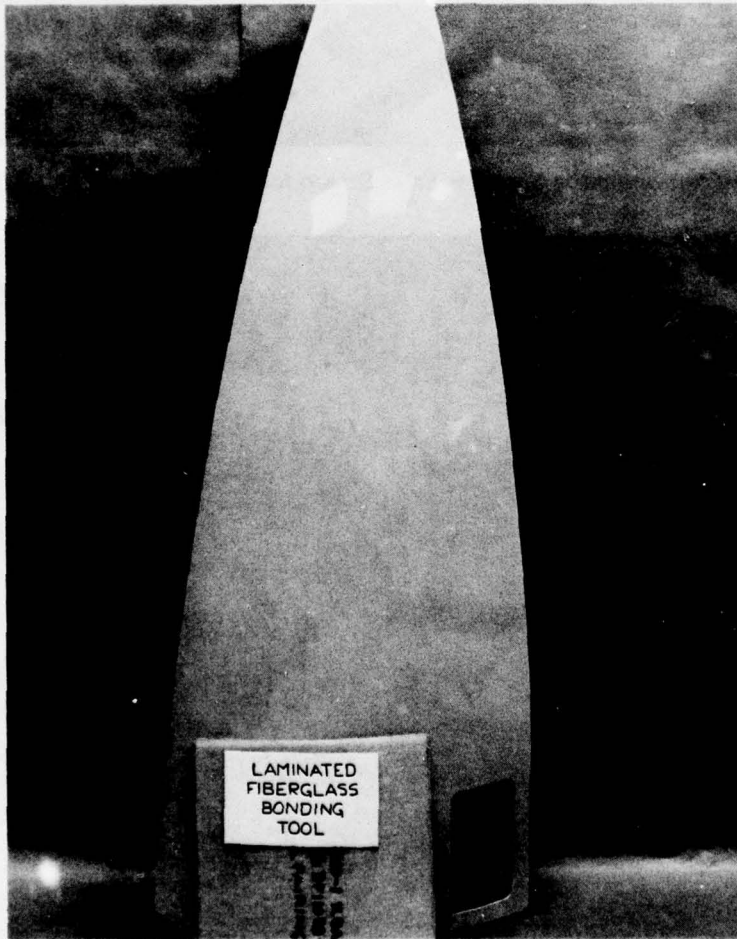

Figure 47.—C-141 APU Access Panel—Repaired Panel

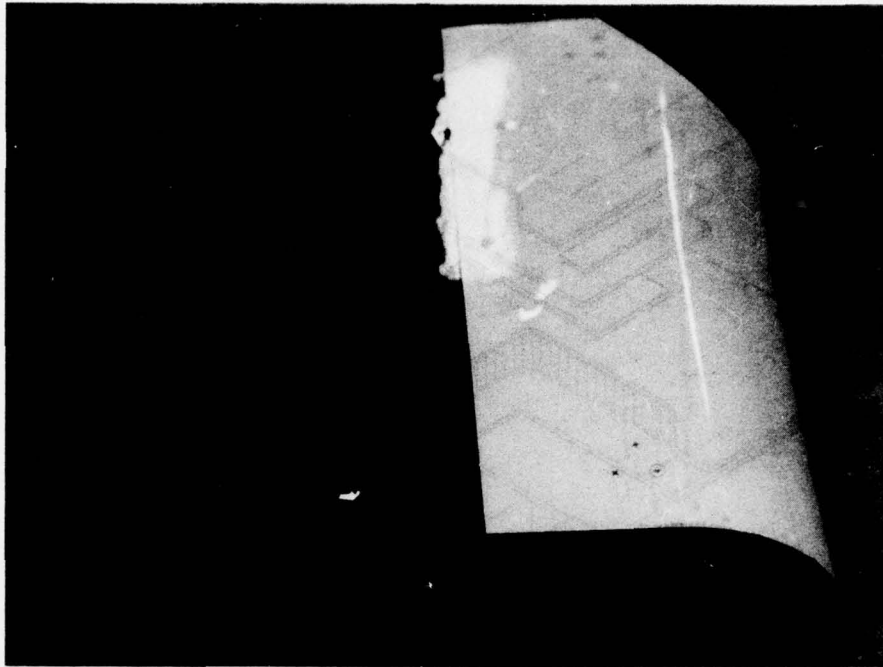

Figure 48.—T-38 Main Landing Gear Door Received From Nellis AFB

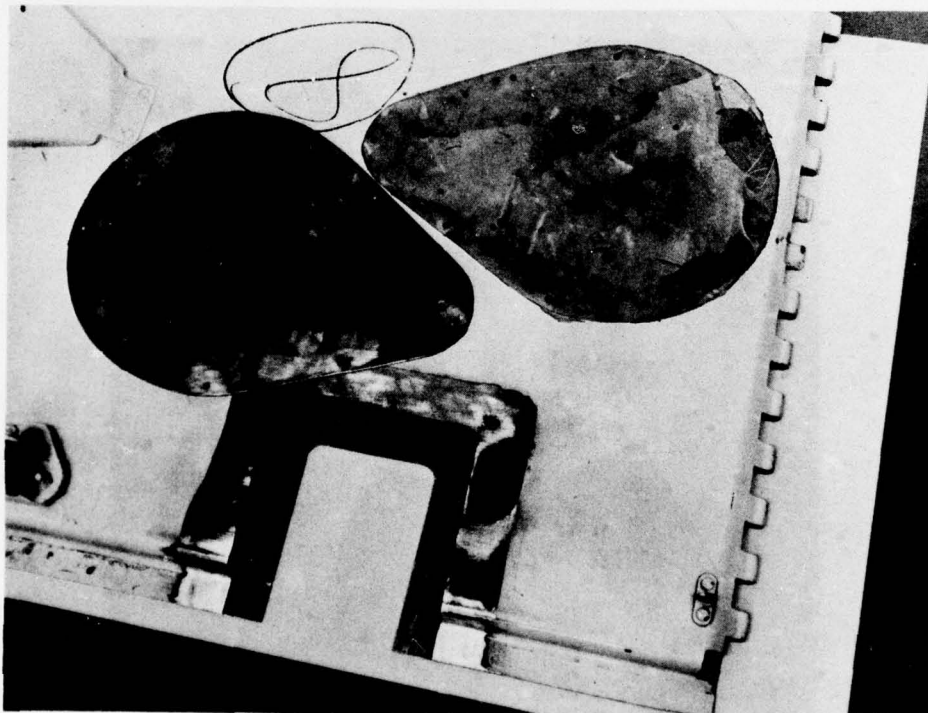

Figure 49.—Removal of Delaminated Doubler and Simulated Edge Damage

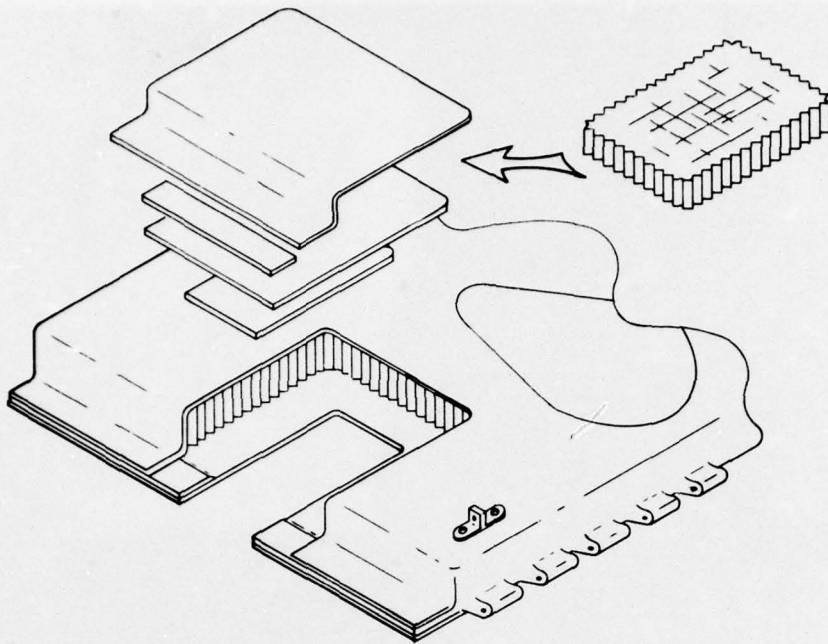

Figure 50.—Exploded View of Repair Details for the T-38 Main Landing Gear Door

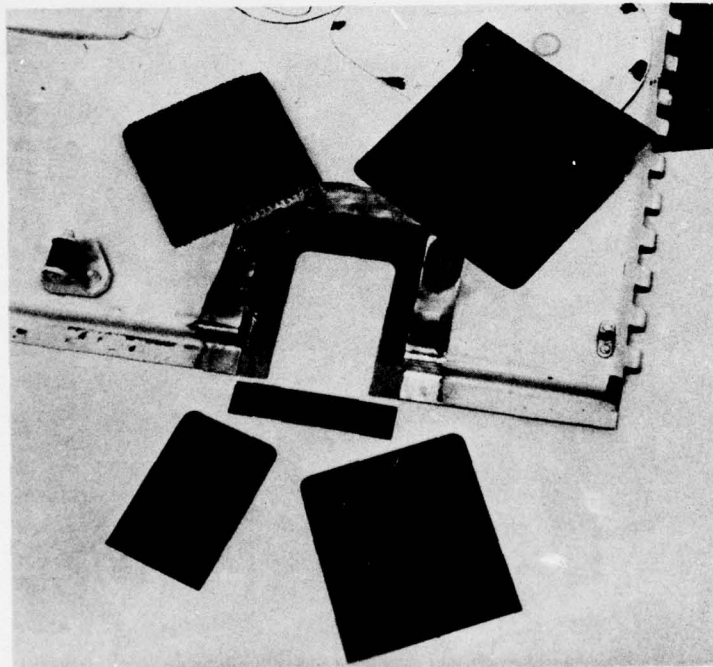

Figure 51.—Repair Details Prior to Assembly

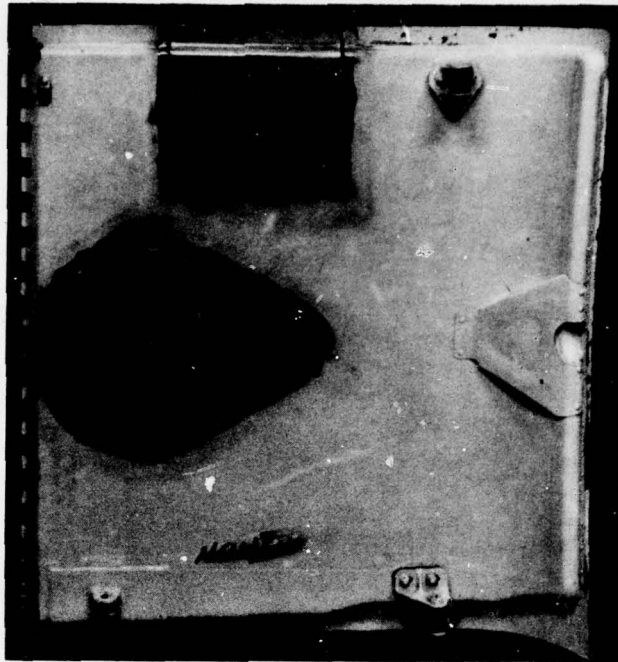

Figure 52.—T-38 Main Landing Gear Door After Bonding the Repair Details

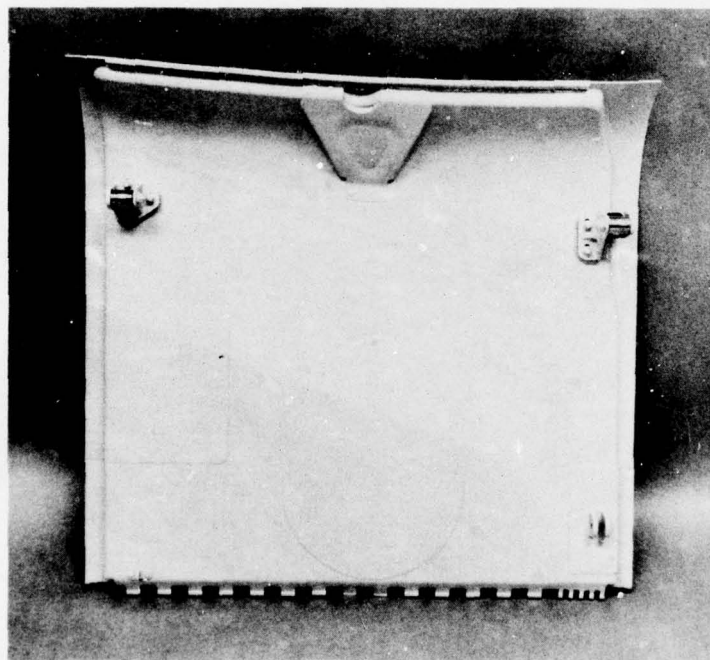

Figure 53.—T-38 Main Landing Gear Door—Repaired Panel

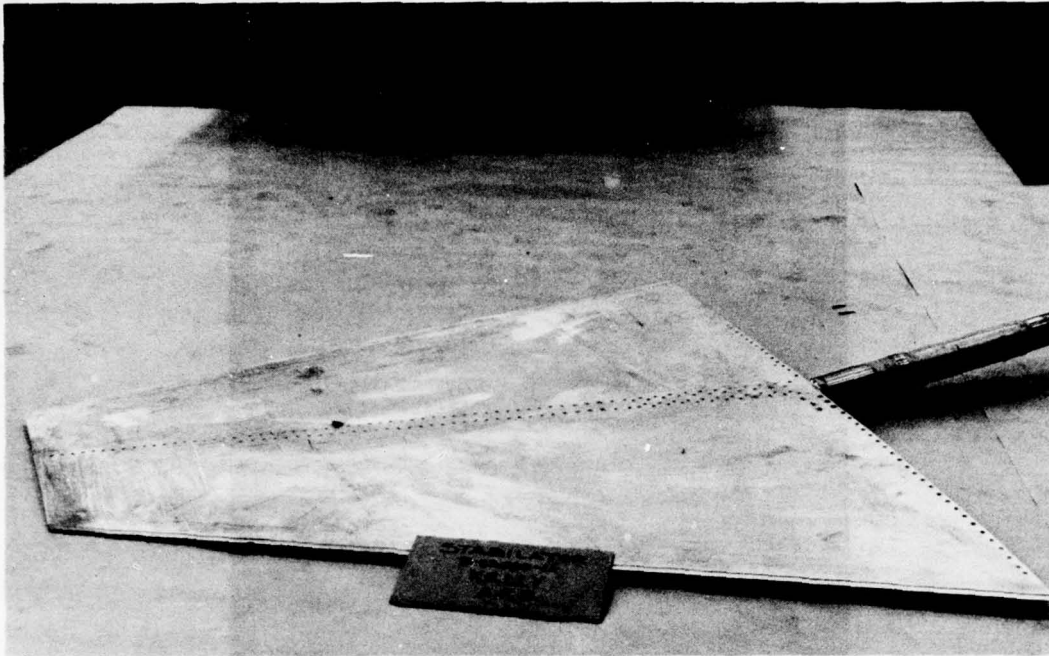

Figure 54.—T-38 Horizontal Stabilator Received From Kelly AFB

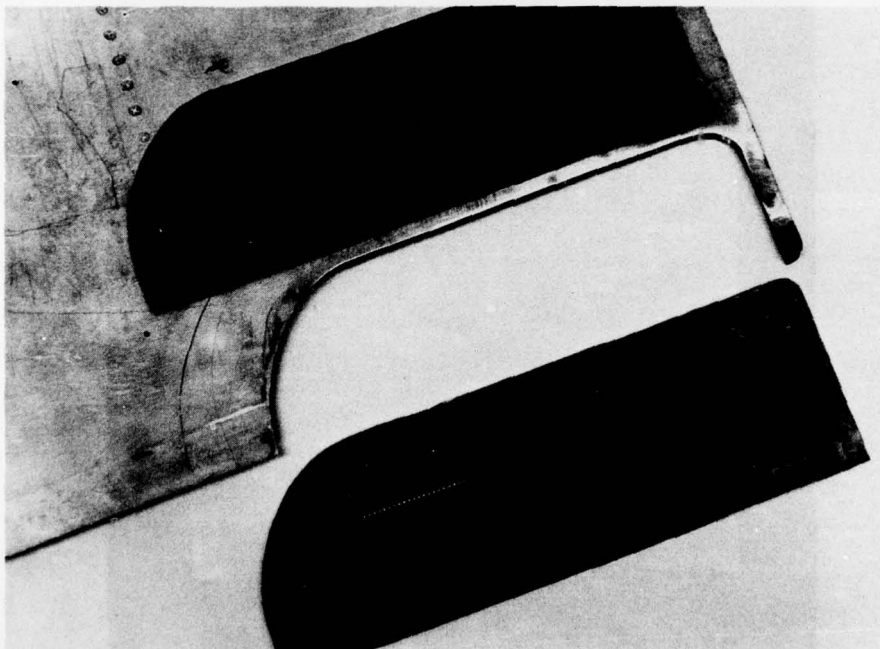

Figure 55.—T-38 Horizontal Stabilator Showing Simulated Trailing Edge Damage Removed and Repair Details

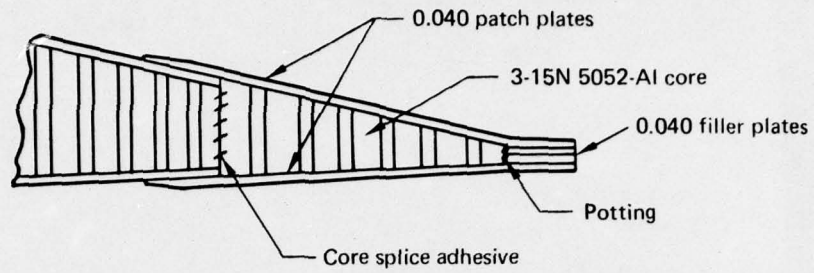

Figure 56.—Cross Section of the T-38 Horizontal Stabilator Trailing Edge Repair

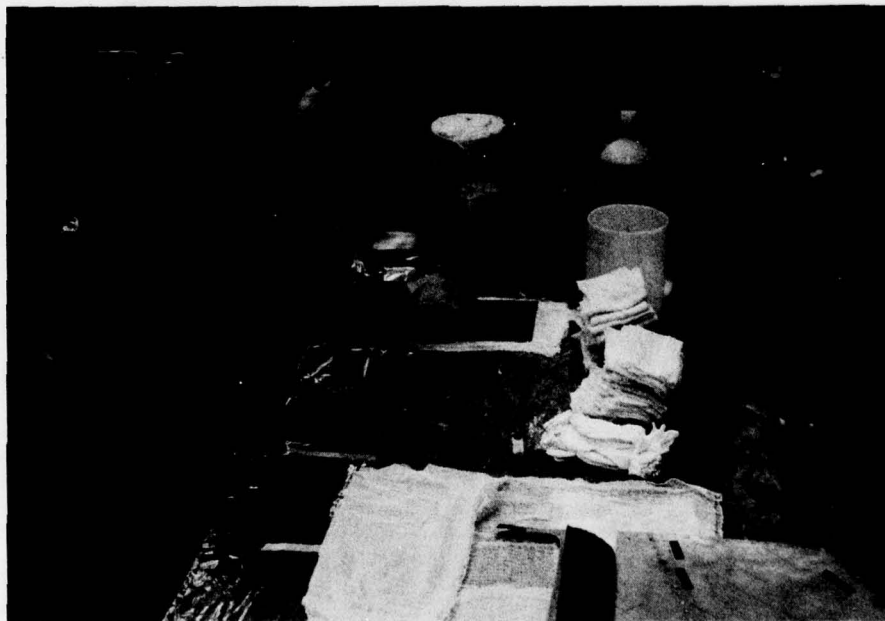

Figure 57.—Anodizing the Patch Plates for the T-38 Stabilator Repair

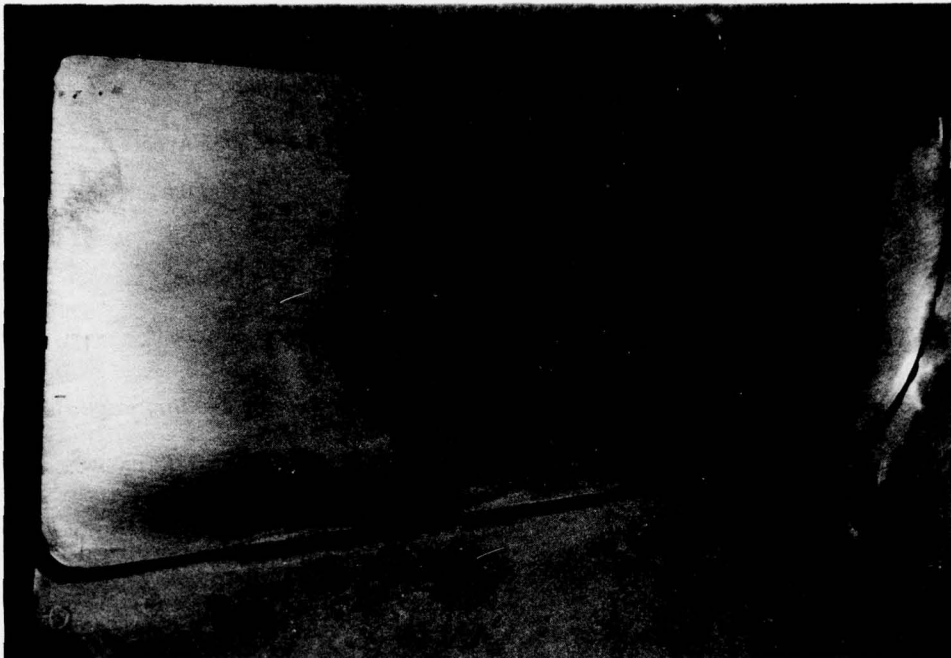

Figure 58.—Closeup of the T-38 Horizontal Stabilator Repair After Bonding

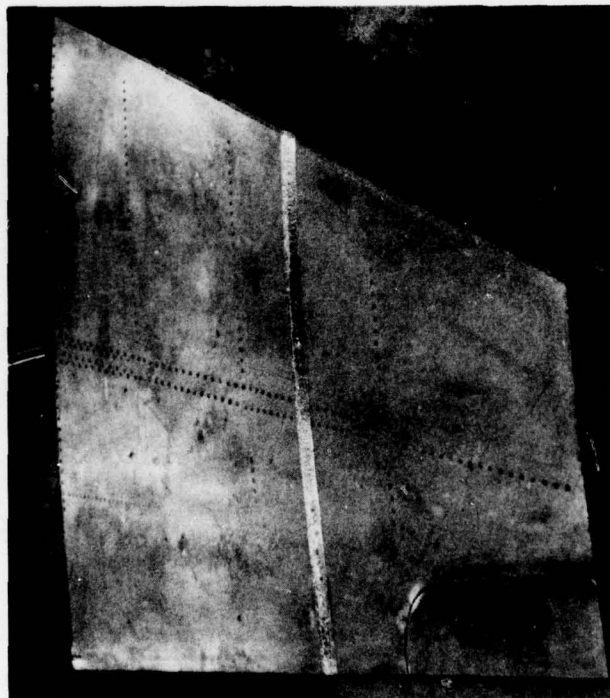

Figure 59.—T-38 Horizontal Stabilator After Repair

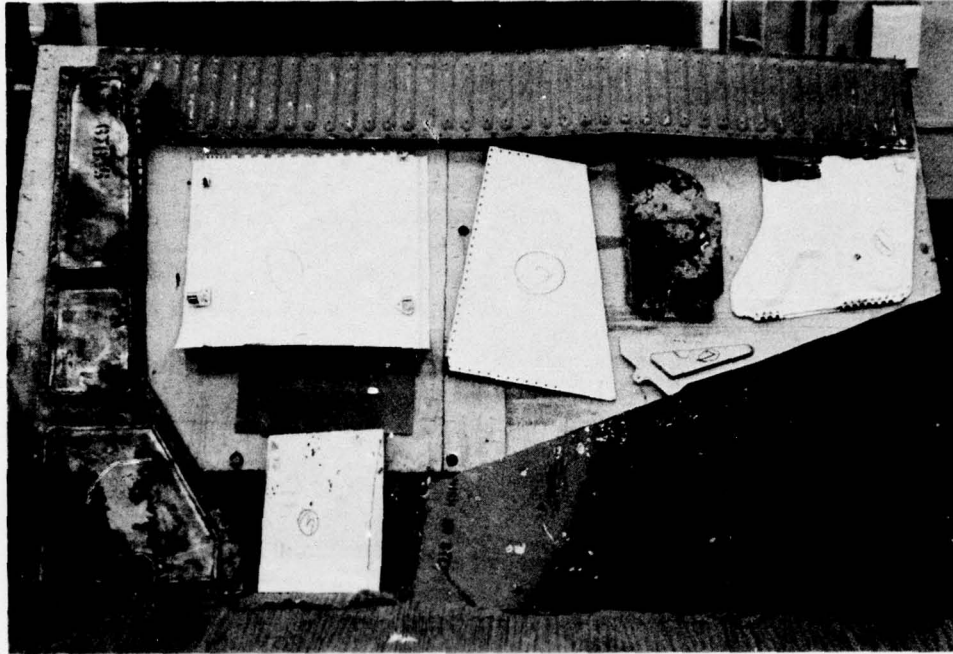

Figure 60.—Damaged Aircraft Parts Received From Nellis AFB (F-111 Titanium Fuselage Panel at Left)

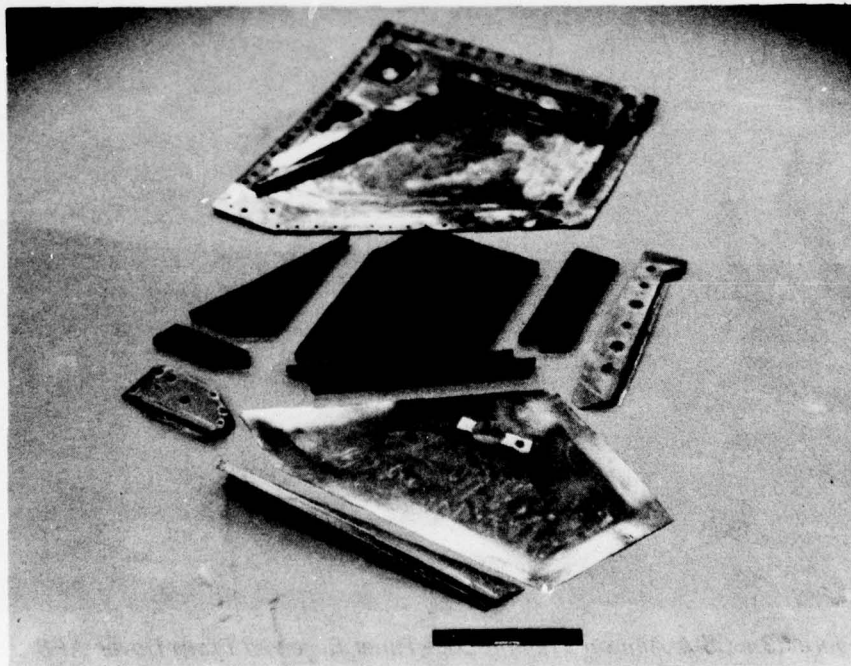

Figure 61.—Repair Details for F-111 Titanium Fuselage Panel Section

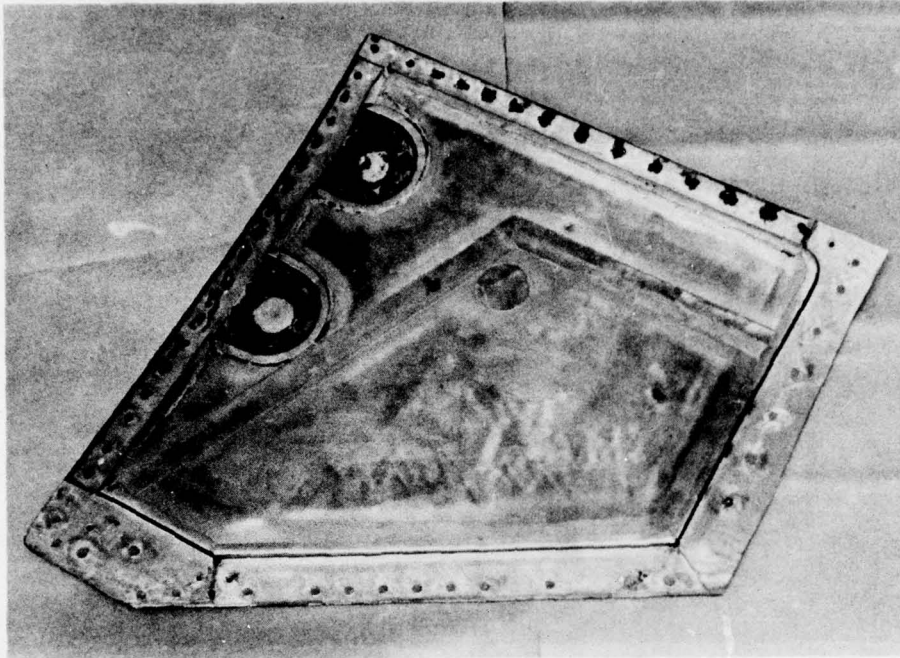

Figure 62.—F-111 Titanium Fuselage Panel Section After Repair

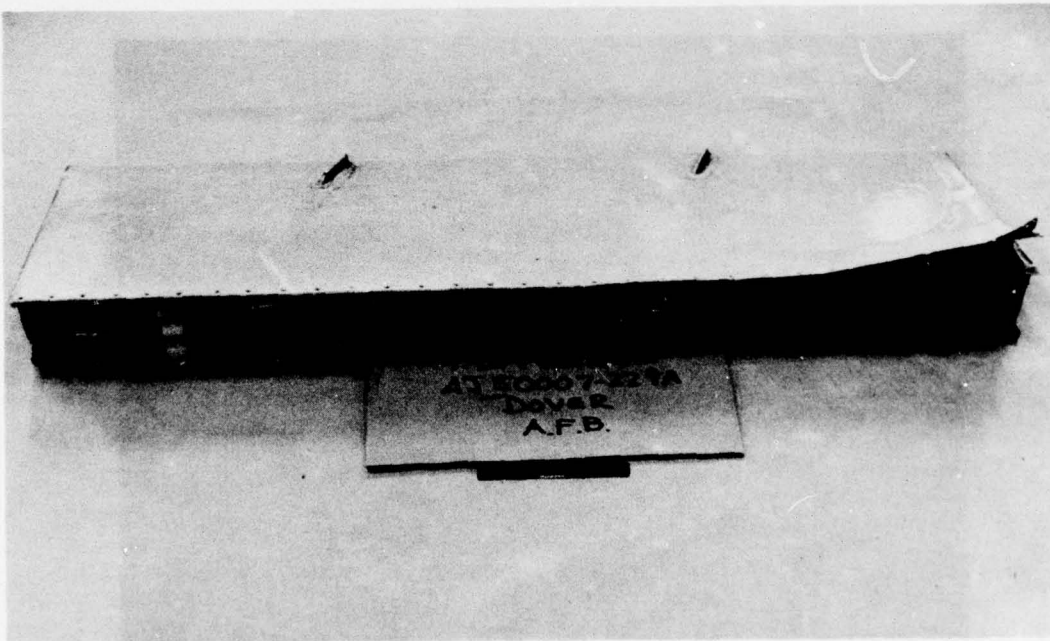

Figure 63.—C5-A Aileron Trailing Edge Panel Received From Dover AFB

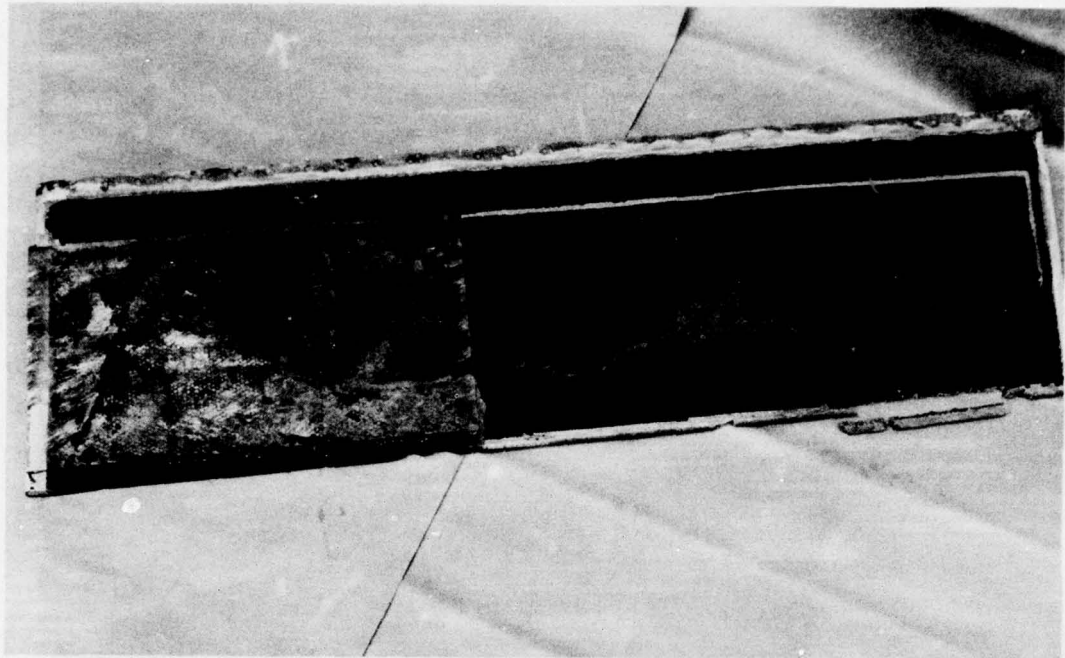

Figure 64.—Interior Condition of C5-A Aileron Trailing Edge Panel Prior to Repair

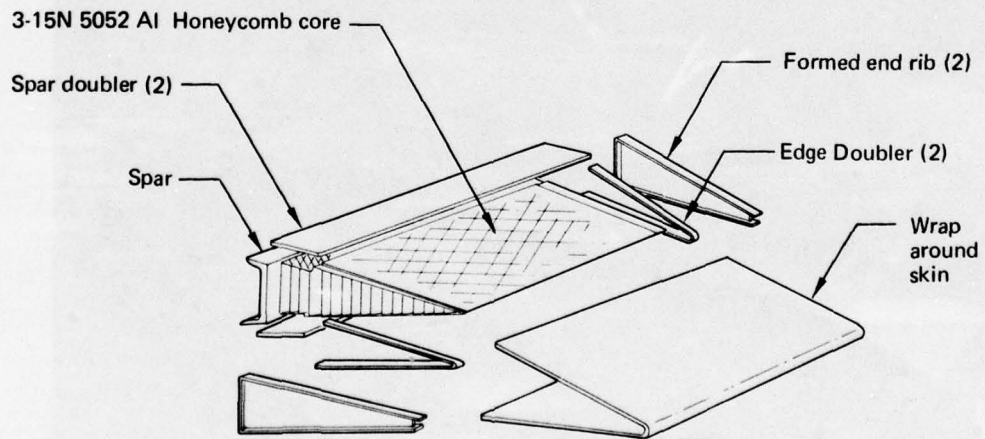

Figure 65.—C5-A Aileron Trailing Edge Part Breakdown

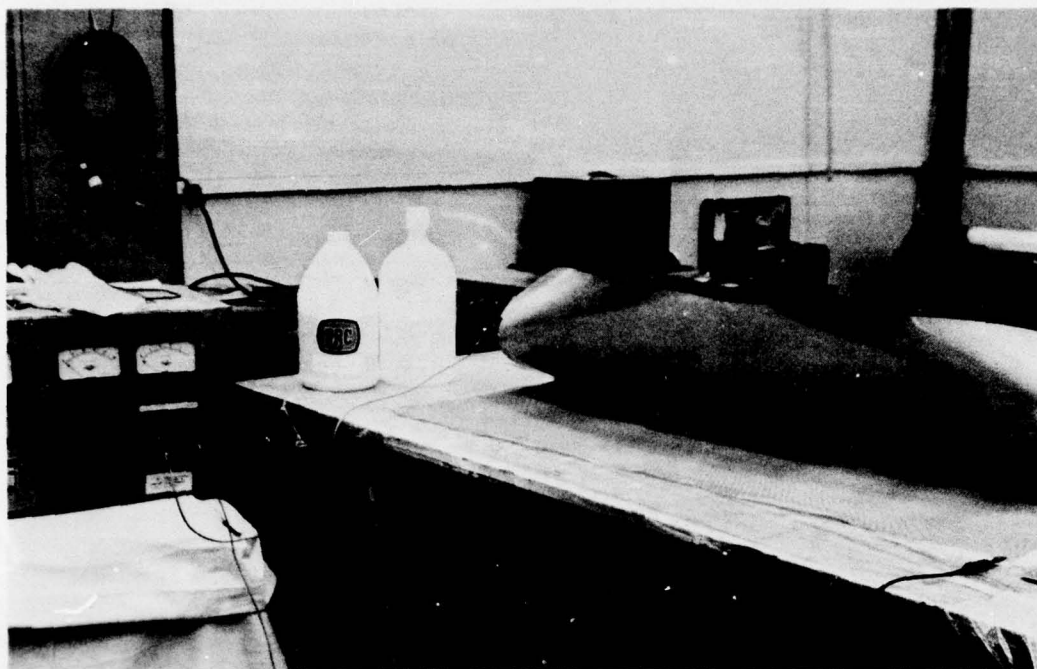

Figure 66.—Anodizing the Lower Half of the C5-A Trailing Edge Panel Skin



Figure 67.—C5-A Aileron Trailing Edge Repair Details Ready for Bonding

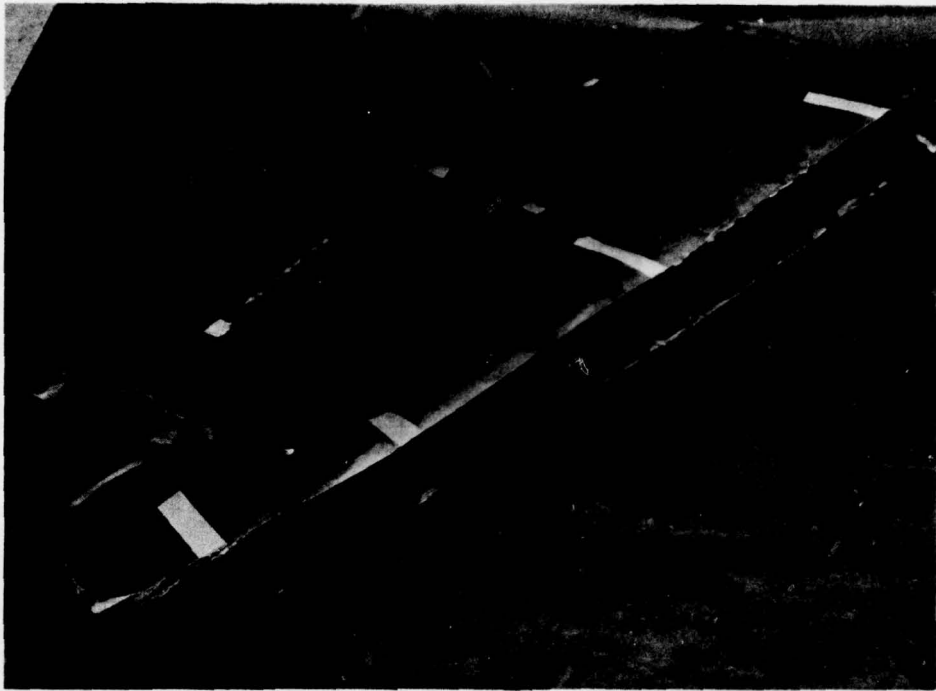

Figure 68.—Trailing Edge Panel After Collapse From Autoclave Pressure During Cure

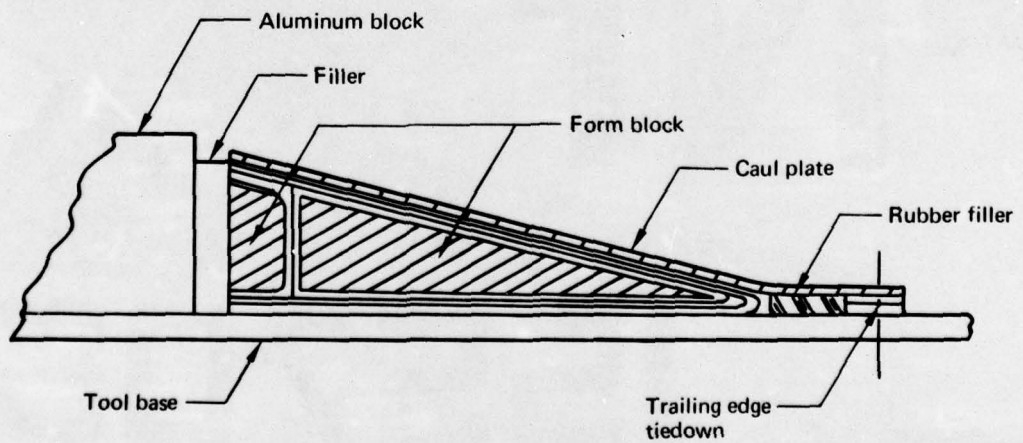

Figure 69.—Tooling Concept to Support the Trailing Edge Panel During the Rebuilding Cure



Figure 70.—Rebuilt C5-A Aileron Trailing Edge Panel



Figure 71.—Damaged A-6 Vertical Fin Received From the Norfolk Naval Air Station



Figure 72.—Closeup of Damage to the A-6 Fin Panel Exterior Surface

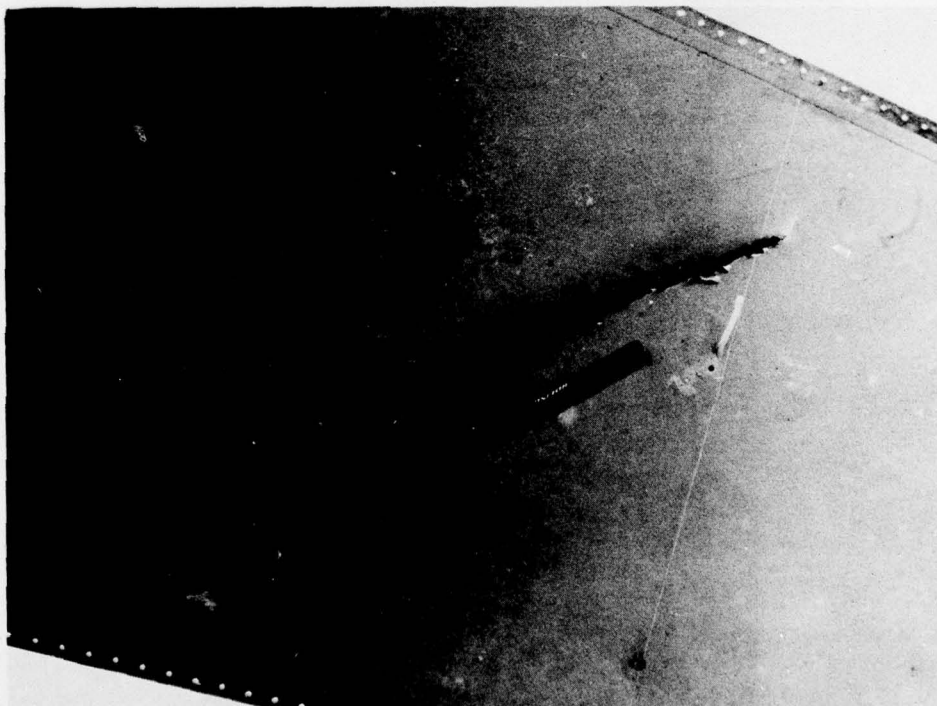

Figure 73.—Closeup of Damage to the A-6 Fin Panel Interior Surface



Figure 74.—Cosmetically Filled Fin Panel to be Used as Base for Molding the Fiberglass Bond Assembly Jig

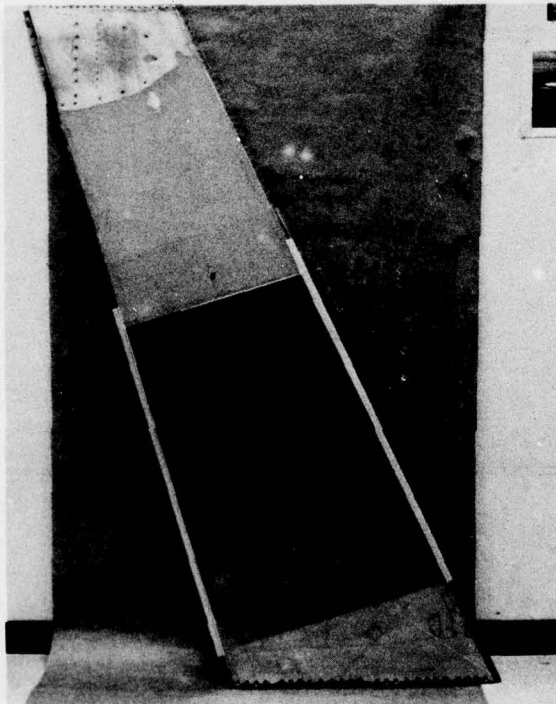

Figure 75.—Metal Contour Sheet Placed Over the Panel to Provide a Surface for Molding the Fiberglass Bond Assembly Jig

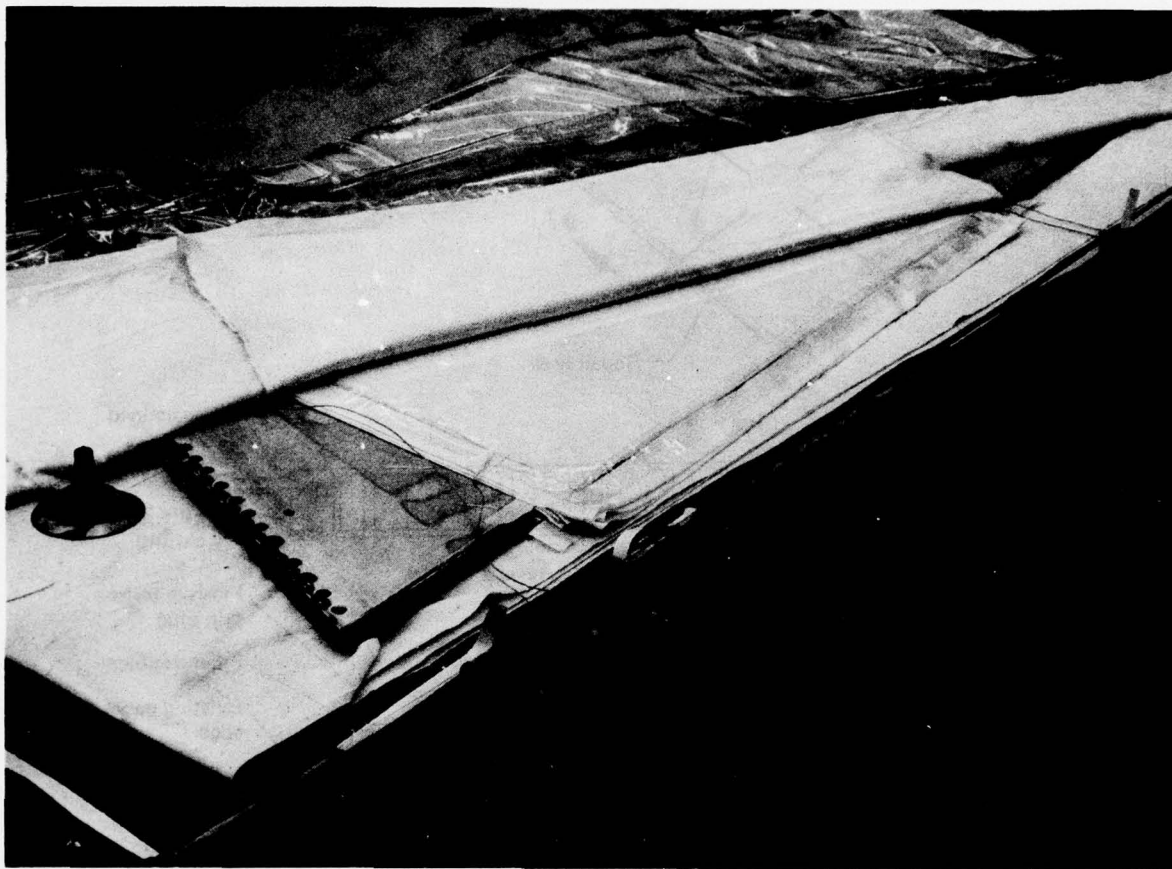

Figure 76.—Fin Panel and Fiberglass Bond Assembly Jig Being Bagged for Cure

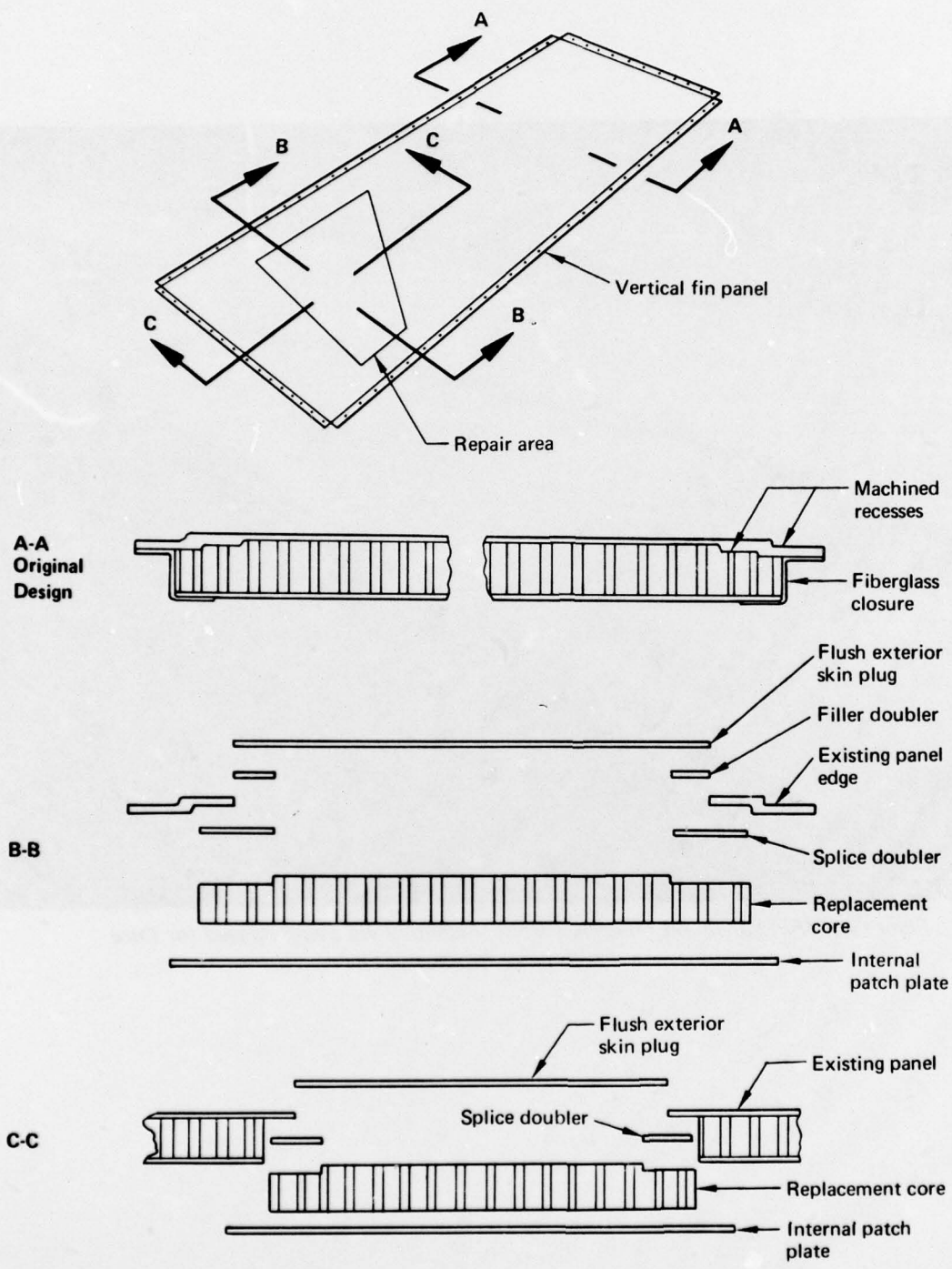

Figure 77.—Detail Cross-Sections of the A-6 Fin Panel Repair

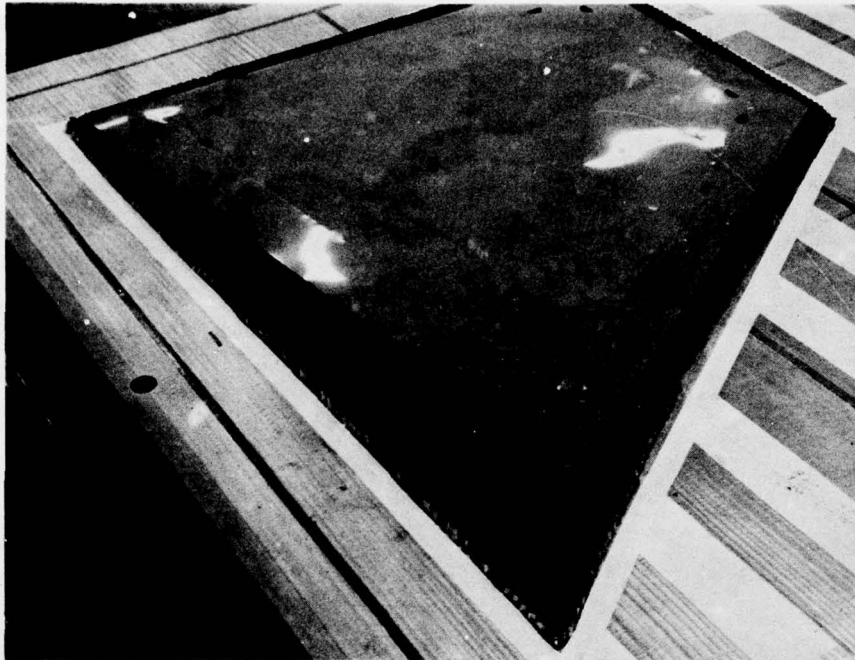

Figure 78.—Mylar Template to Define the Core Outline and Edge Recesses

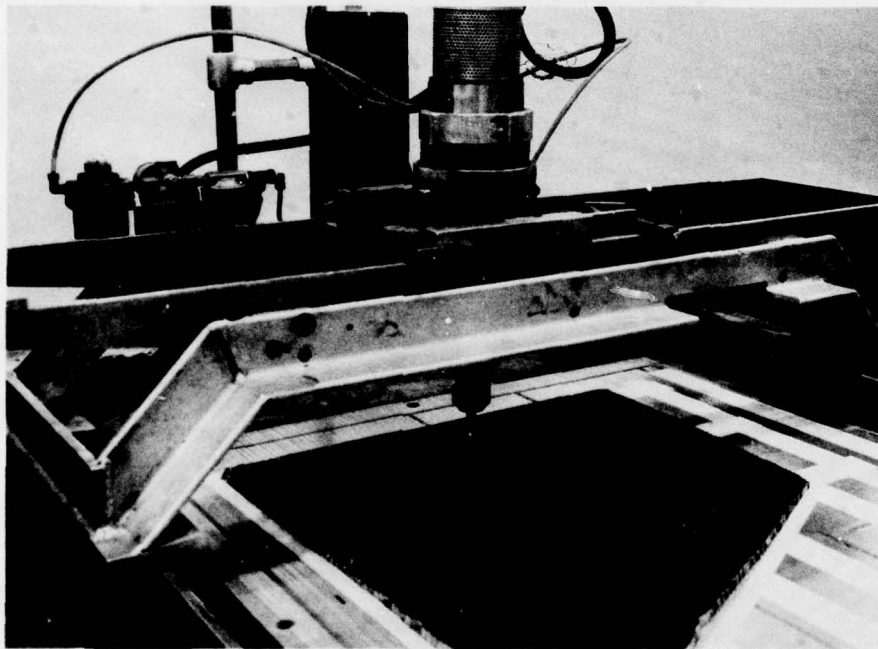

Figure 79.—Machining the Core With the High-Speed Surfacing Machine

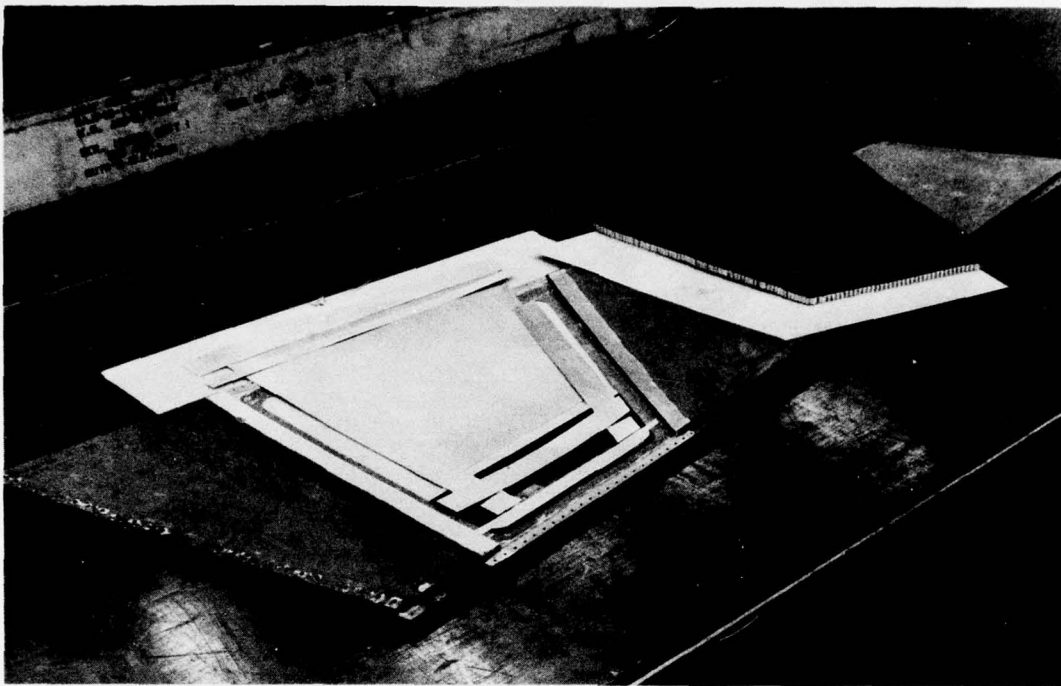

Figure 80.—A-6 Fin Repair Details Ready for Assembly

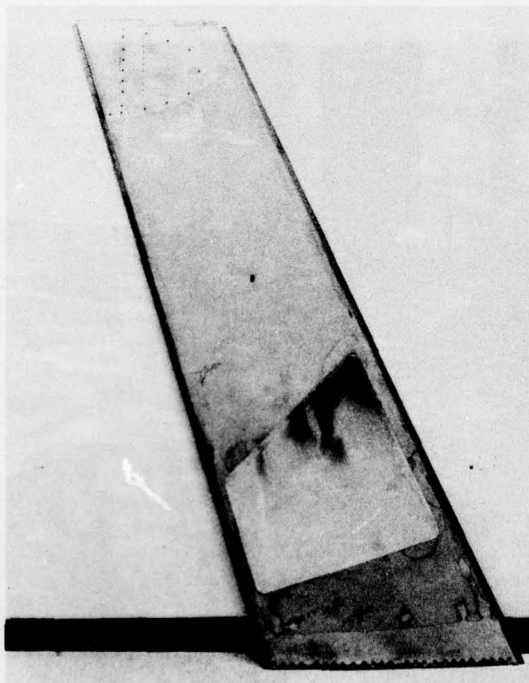

Figure 81.—Exterior Surface of the Fin Panel After Bonding

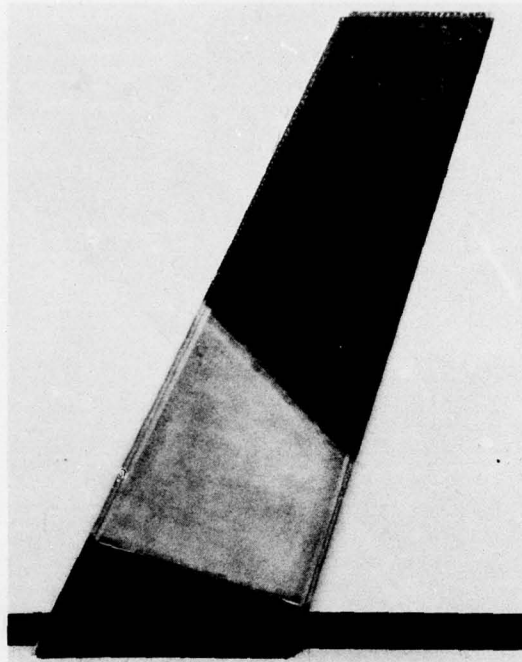

Figure 82.—Interior Surface of the Fin Panel After Bonding

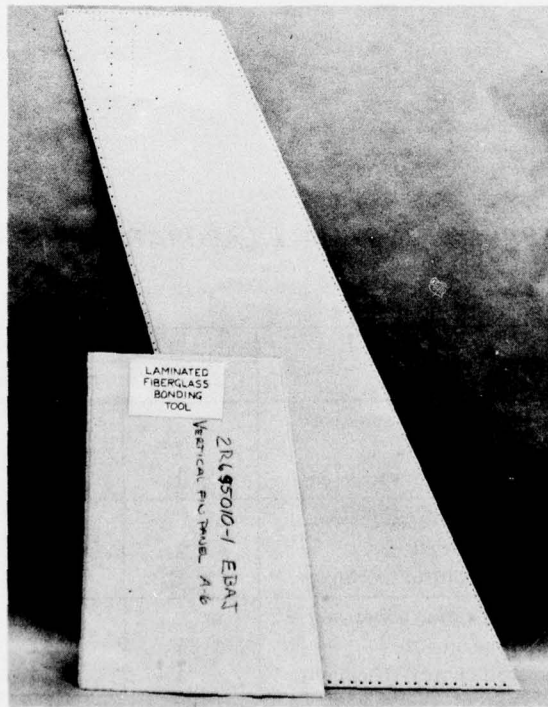

Figure 83.—A-6 Vertical Fin With Repair Completed

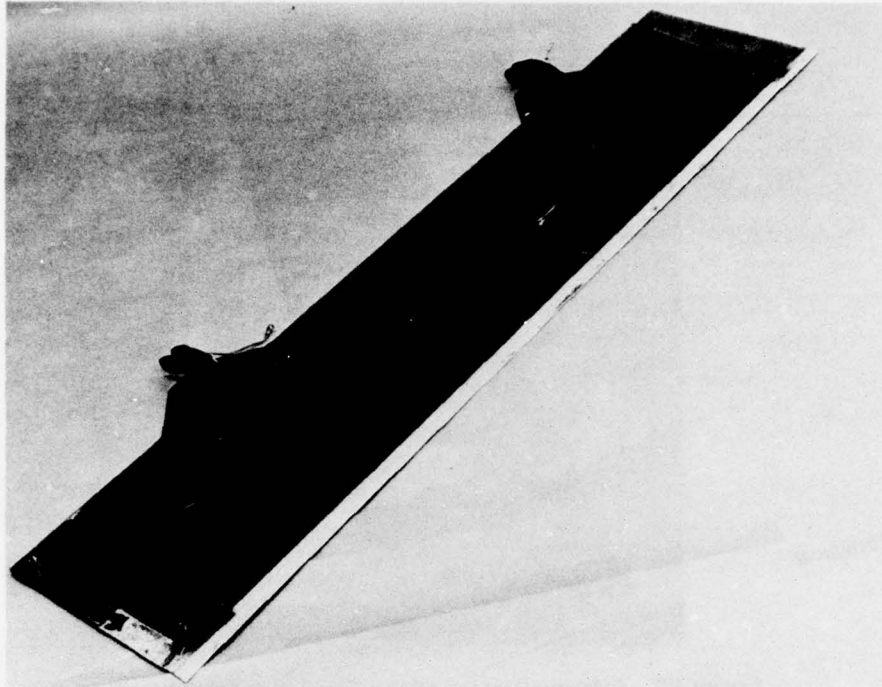

Figure 84.—F-111 Outboard Spoiler Received From Sacramento ALC

TABLE 1.—TEST PLAN FOR SMALL LABORATORY REPAIR SPECIMENS

Material type	Test type and number		
	Tension	Compression	Fatigue
Aluminum: 250° F curing adhesive			
Repaired specimens	1	1	3
Undamaged control specimens	1	1	3
Aluminum: 350° F curing adhesive			
Repaired specimens	1	1	3
Undamaged control specimens	1	1	3
Titanium: 350° F curing adhesive			
Repaired specimens	1	1	3
Undamaged control specimens	1	1	3

TABLE 2.—MATERIALS USED IN THE SMALL AREA REPAIR SPECIMENS

Item ^a	Adhesive system		
	AF127-3	AF130	FM400
1 Skins	0.020 2024-T3 clad	0.020 2023-T3 clad	0.012 6Al-4V Ti An
2 Core	3-10 5052 Al	3-10 5052 Al	3-10 5052 Al
3 Skin plug	0.020 2024-T3 clad 1 in. diameter	0.020 2024-T3 clad 1 in. diameter	0.012 6Al-4V Ti An 1 in. diameter
4 Internal patch plate	0.020 2024-T3 clad 3 in. diameter	0.020 2024-T3 clad 3 in. diameter	0.012 6Al-4V Ti An 3 in. diameter
5 Core plug	3-10 5052 Al ^b	3-10 5052 Al ^b	3-10 5052 Al ^b
6 External patch plate	0.020 2024-T3 clad 5 in. diameter	0.010 2024-T3 clad 5.5 in. diameter	0.012 6Al-4V Ti An 5 in. diameter
7 External patch plate	None	0.010 2024-T3 clad 4.5 in. diameter	None
8 End doubler	0.020 2024-T3 clad	0.020 2024-T3 clad	0.012 6Al-4V Ti An
9 Filler block core splice adhesive	2024-T3 thermofoam 3050-250	2024-T3 thermofoam 3050-350	CRS thermofoam 3050-350

^aSee figure 3.

^b3/16-in. cell size, 0.0010-in. cell foil thickness.

TABLE 3.—CURING PROCEDURES FOR THE ADHESIVES AND PRIMERS

Item	Type system		
	Moderate temperature, aluminum	High temperature, aluminum	High temperature, titanium
Adhesive film	AF127-3	AF130	FM400
Cure	200°F for 120 min, vacuum bag (24 to 27 Hg)	270°F for 120 min, vacuum bag (24 to 27 Hg)	350°F for 60 min, vacuum bag (24 to 27 Hg)
Primer	EC3921 ^a	EC2333 ^a	BR400 ^a
Cure	Room temperature 60 min, 0.0001 to 0.0002 in. thick	Room temperature 30 min, plus 160°F for 30 min, 0.0001 to 0.0003 in. thick	Room temperature 10 min, plus 200°F for 30 min, 0.0002 to 0.0005 in. thick
Core splice adhesive	Thermofoam 3050	Thermofoam 3050	Thermofoam 3050
Cure	Same as the adhesive film	Same as the adhesive film	Same as the adhesive film

^aNoncorrosion inhibiting type.

TABLE 4.—PROCEDURE USED TO PREPARE THE ALUMINUM SKIN SURFACES FOR BONDING

Phosphoric Acid Nontank Anodize Method

1. Solvent wipe with methylethylketone, trichloroethylene or equivalent
2. Abrade with Scotchbrite type A to remove surface contaminants
3. Wipe dry with clean gauze
4. Apply a uniform coat of gelled phosphoric acid (10% to 12%) PR-50^a
5. Place one or two layers of gauze over the coating
6. Apply a coat of PR-50 over the gauze
7. Secure a piece of stainless steel wire screen^b over gauze
8. Connect screen as cathode (-) and aluminum substrate as anode (+)
9. Apply a potential of 4 to 6 volts for 10 to 12 min (current density in the range of 2 to 6 amps per square foot)
10. At the end of anodizing time, open circuit, remove screen and gauze, and lightly wipe off gelled acid coating
11. Moisten clean gauze with water, lightly wipe-rinse anodize surfaces
CAUTION: Do not rub surface. Test with litmus paper to ensure that all trace of acid has been removed.
12. Air dry 30-min minimum or heat dry
CAUTION: Do not touch surface with anything.
13. Prime and bond or bond as soon as practical

^aPR-50—gelled phosphoric acid 10% to 12% from Products Research Corporation.

^bStainless steel screen, any mesh.

TABLE 5.—PROCEDURE USED TO PREPARE THE TITANIUM SKIN SURFACES FOR BONDING

Surface Preparation, Titanium; PasaJell 107 Method

1. Solvent clean with methylethylketone or equivalent using clean cloth
2. Abrade surface with 320 grit nonsilicone wet or dry sandpaper
3. Mask off area with mylar tape (Mystic 7331 or equivalent)
4. Wipe sanded area with trichloroethylene on gauze
5. Coat with PasaJell 107^a and allow to stand for 12 to 16 min
6. Flush treated surface with water to remove PasaJell 107. Test with litmus for neutrality.
7. Dry treated area (room temp or to 150°F).
8. Prime and bond

^aFrom Products Research Corporation

**TABLE 6.—TEST RESULTS FOR THE SMALL AREA REPAIR
STATIC TEST SPECIMENS**

Spec no.	Types of loading	Type of specimen	Metal adherent	Adhesive	Failing load lbs
1-1	Tension	Control	2024-T3	AF127-3	15,860
1-5	Tension	Repaired	2024-T3	AF127-3	14,960
2-1	Tension	Control	2024-T3	AF130	13,900
2-5	Tension	Repaired	2024-T3	AF130	13,980
3-1	Tension	Control	6Al-4V	FM400	21,360
3-5	Tension	Repaired	6Al-4V	FM400	18,800
4-1	Comp.	Control	2024-T3	AF127-3	12,040
4-2	Comp.	Repaired	2024-T3	AF127-3	11,750
5-1	Comp.	Control	2024-T3	AF130	11,380
5-2	Comp.	Repaired	2024-T3	AF130	12,740
6-1	Comp.	Control	6Al-4V	FM400	13,200
6-2	Comp.	Repaired	6Al-4V	FM400	16,240

TABLE 7.—FATIGUE TEST RESULTS FOR THE SMALL AREA REPAIRS (R = -1.0)

Spec. no.	Spec. type	Skin material	Adhesive	Maximum load, lb	Maximum skin stress ksi	Cycles to failure	Percent ^a control	
1-2	Control	2024-T3	AF127-3	7200	30	18 x 10 ³	101	
1-3	Control	2024-T3	AF127-3	5200	22	64 x 10 ³		
1-4	Control	2024-T3	AF127-3	5200	22	105 x 10 ³		
1-6	Repaired	2024-T3	AF127-3	5200	22	78 x 10 ³		
1-7	Repaired	2024-T3	AF127-3	5200	22	130 x 10 ³		
1-8	Repaired	2024-T3	AF127-3	5200	22	66 x 10 ³		
2-2	Control	2024-T3	AF130	5200	22	77 x 10 ³		100
2-3	Control	2024-T3	AF130	5200	22	126 x 10 ³		
2-4	Control	2024-T3	AF130	5200	22	123 x 10 ³		
2-6	Repaired	2024-T3	AF130	5200	22	136 x 10 ³		
2-7	Repaired	2024-T3	AF130	5200	22	76 x 10 ³		
2-8	Repaired	2024-T3	AF130	5200	22	114 x 10 ³		
3-2	Control	6Al-4V	FM400	5800	40	7 x 10 ⁶⁺	72.5	
3-3	Control	6Al-4V	FM400	8400	60	48 x 10 ³		
3-4	Control	6Al-4V	FM400	8400	60	46 x 10 ³		
3-6	Repaired	6Al-4V	FM400	8400	60	1 ^b		
3-7	Repaired	6Al-4V	FM400	8400	60	1 x 10 ³		
3-8	Repaired	6Al-4V	FM400	8400	60	3 x 10 ³		

^aBased on the log mean average.

^bFailure in the base metal area.