

AD-A035 774

NAVAL RESEARCH LAB WASHINGTON D C
NRL'S CENTRAL ATMOSPHERE MONITOR PROGRAM.(U)
DEC 76 F E SAALFELD, J R WYATT
NRL-MR-3432

F/G 13/10.1

UNCLASSIFIED

NL

| OF |
AD
A035774

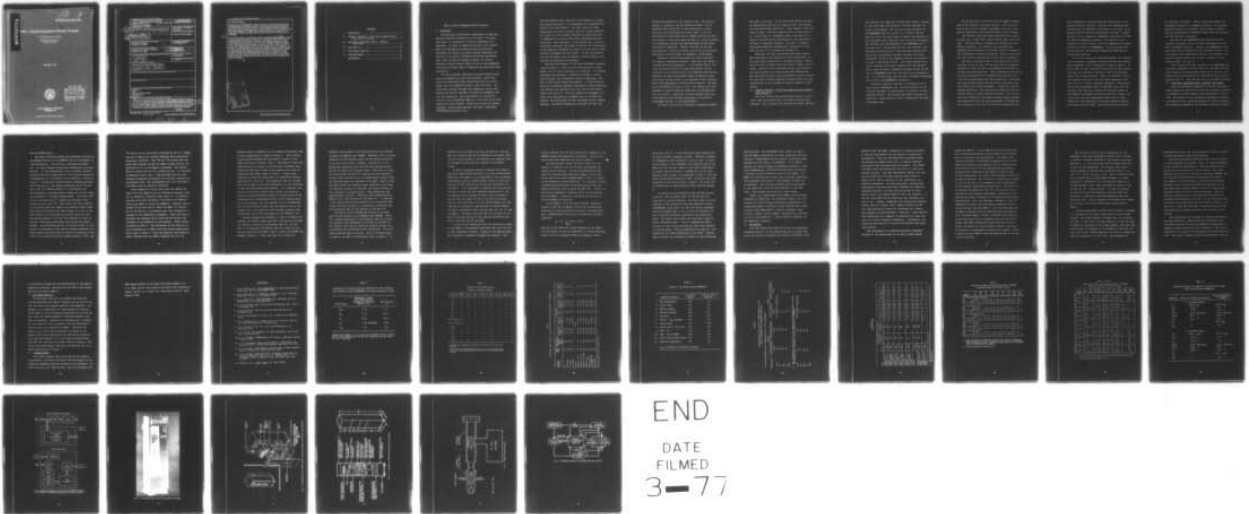

12 J

NRL Memorandum Report 3432

ADA 035774

NRL's Central Atmosphere Monitor Program

F. E. SAALFELD AND J. R. WYATT

*Physical Chemistry Branch
Chemistry Division*

December 1976



DDC
RECEIVED
FEB 18 1977
A

NAVAL RESEARCH LABORATORY
Washington, D.C.

SECURITY CLASSIFICATION OF THIS PAGE (When Data Entered)

9 REPORT DOCUMENTATION PAGE		READ INSTRUCTIONS BEFORE COMPLETING FORM
1. REPORT NUMBER NRL Memorandum Report 3432	2. GOVT ACCESSION NO.	3. RECIPIENT'S CATALOG NUMBER
4. TITLE (and Subtitle) NRL'S CENTRAL ATMOSPHERE MONITOR PROGRAM	5. TYPE OF REPORT & PERIOD COVERED Interim report on a continuing NRL problem.	
6. AUTHOR(s) F.E. Saalfeld and J.R. Wyatt	6. PERFORMING ORG. REPORT NUMBER	
7. PERFORMING ORGANIZATION NAME AND ADDRESS Naval Research Laboratory Washington, D.C. 20375	8. CONTRACT OR GRANT NUMBER(s)	
9. CONTROLLING OFFICE NAME AND ADDRESS Naval Sea Systems Command (Code 0331) Washington, D.C. 20362	10. PROGRAM ELEMENT, PROJECT, TASK AREA & WORK UNIT NUMBERS NRL Problem C07-08	
11. MONITORING AGENCY NAME & ADDRESS (if different from Controlling Office) 12 H8p.	12. REPORT DATE December 1976	
13. DISTRIBUTION STATEMENT (of this Report) Approved for public release; distribution unlimited. 14 NRL-MR-3432	13. NUMBER OF PAGES 47	
14. DISTRIBUTION STATEMENT (of the abstract entered in Block 20, if different from Report)	15. SECURITY CLASS. (of this report) UNCLASSIFIED	
15. SUPPLEMENTARY NOTES	15a. DECLASSIFICATION/DOWNGRADING SCHEDULE	
16. KEY WORDS (Continue on reverse side if necessary and identify by block number) Spectroscopy CAMS Submarine atmosphere analysis Mass spectrometry Life support		
20. ABSTRACT (Continue on reverse side if necessary and identify by block number) To meet the operational requirement of having submarines remain submerged for periods up to 90 days, it is necessary to have a pure atmosphere for the survivability of the crew. This requires some method for analyzing the submarine atmosphere. Early nuclear-powered submarines used a series of atmosphere analyzers, Mark II, Mark III, Mark IV, Mark V and the Mark VI. None of these instruments was very reliable. Therefore, in 1970, the Naval Research Laboratory (NRL) instituted an atmosphere monitoring program that has become known as the CAMS (Central Atmosphere (Continues)		

next page

DD FORM 1 JAN 73 1473

EDITION OF 1 NOV 68 IS OBSOLETE
S/N 0102-014-6601

SECURITY CLASSIFICATION OF THIS PAGE (When Data Entered)

251 950 LB

20. Abstract (Continued)

Monitor System). The CAMS program consists of three phases, the Mark I, Mark II and Mark IIB, or CAMS-I, CAMS-II and CAMS-IIB. The CAMS I is a fixed collector mass spectrometer coupled with a infrared carbon monoxide (CO) detector. CAMS-I has passed technical and operational evaluation and is the first atmosphere analyzer ever to be "service approved." However, CAMS-I can only monitor eight constituents. To monitor another constituent, which would be necessary if a new weapon system containing a potentially harmful compound is deployed, the CAMS-I would have to be redesigned.

cont.

→ The current system under development, CAMS-II, will ~~alleviate this problem by using a computer-~~ ^{use} controlled scanning mass spectrometer. Therefore, any compound that is introduced into the submarine's atmosphere can, in principle, be monitored by only a program change in the computer. CAMS-II also uses an infrared detector to monitor CO. The CAMS-IIB, an integrated life support system, is the last stage of the CAMS program. If CAMS-II is as reliable as CAMS-I, the CAMS-II computer system will be expanded to control the entire life support system of the submarine. For example, in the CAMS-IIB system, when the oxygen concentration decreases the CAMS-IIB computer automatically increases the oxygen concentration of the submarine to the desired level by adjusting the oxygen generator output. Similarly the CAMS-IIB will control the CO₂ scrubber, monitor the carbon bed status for contaminant breakthroughs, and adjust the temperature of the CO/H₂ catalytic burner. Thus, with the CAMS-IIB system it will be possible to reduce the crew needed to support the submarine life support system and also to improve the quality of the atmosphere available on the submarine.



REVISION	
NTIS	
ZDC	
UNANNOUNCED	
JUSTIFICATION	
BY	
DISTRIBUTION/AVAILABILITY CODES	
Dist.	GEN. / SPEC.
A	

CONTENTS

I. BACKGROUND 1

II. PROJECT "UPTIGHT" - The First Submarine Mass Spectrometer Analyzer..... 4

III. THE CAMS-I PROTOTYPE UNITS - PROJECT "TOO TIGHT" 8

IV. THE CAMS-II 18

V. THE FUTURE CAMS-IIB 25

VI. ACKNOWLEDGMENT 25

REFERENCES 27

NRL's Central Atmosphere Monitor Program

I. BACKGROUND

The Navy has an operational requirement to keep submarines sealed for periods of up to 90 days. To obtain this goal it is necessary to minimize atmosphere contaminants. In order to assess the status of the requirement, the atmosphere contaminants must be monitored. Throughout the history of nuclear-powered submarines the Navy has tried several atmosphere monitoring approaches. This report reviews the present program, the Central Atmosphere Monitor System (CAMS) as well as the atmosphere analyzers previously used on submarines and describes their limitations.

The Naval Research Laboratory has been analyzing submarine atmospheres for more than 30 years. Before and during the second World War contaminants such as stibine (SbH_3) from the submarine batteries were monitored. Nuclear power greatly extended the submergence time of submarines and thereby increased the need for atmosphere control and monitoring. NRL participated in a scientific cruise of the USS NAUTILUS (SSN 571), which was one of that submarine's first cruises. During this cruise gas chromatographs, infrared spectrometers, and even a laboratory

Note: Manuscript submitted December 7, 1976.

mass spectrometer were installed on the NAUTILUS to assess the atmosphere quality. The atmosphere of the NAUTILUS was "loaded" with hydrocarbons. The major source of these hydrocarbons was paint thinners, used for routine painting. As a result of this finding, painting on submarines prior to submergence and during operational deployment has been prohibited. More important, it was obvious that a routine analytical instrument was needed to monitor the contaminants in the submarine atmosphere in order to insure that a viable submarine atmosphere was maintained. It was also obvious that the instrument must be accurate, highly reliable, and operable by nonscientific personnel.

NRL began development of the first atmosphere analyzer, called the Mark I. This unit was developed by Dr. Frank Thomas, but was never installed on a submarine. A prototype developed from the Mark I, designated the Mark II atmosphere analyzer, was evaluated on several submarines. The Mark II was really several instruments. It used thermoconductivity to measure hydrogen; paramagnetic oxygen detection; and infrared (IR) sensing of CO, CO₂, and the refrigerant gases, R-11 and R-12. The first production atmosphere analyzer to be installed on a submarine was to the Mark III. However, the shortcomings of this instrument quickly became apparent. The major problems with the Mark III were the

sources and detectors of the infrared units. The sources burned out frequently and the detectors leaked. The IR detectors were susceptible to the accumulation of dust particles and interference from water vapor in the air. Seven years of improvements by Dr. Thomas advanced the Mark III analyzer to the stage where the Mark IV, a fourth generation atmosphere analyzer had been developed and was being installed on submarines. However, the Mark IV also had shortcomings: it was not reliable; and it was not versatile, monitoring a limited number of atmospheric constituents.

Therefore, the Navy considered two other techniques for possible atmosphere analyzers. These were gas chromatography and mass spectrometry. In the middle 1960's, however, the state-of-the-art of mass spectrometry was believed not to be reliable enough for submarine applications. Moreover, the mass spectrometer vendors attempted to measure CO (in the ppm level) in the presence of 80% nitrogen. While this measurement is theoretically possible - the mass N_2 and CO differ by 1 part in 2500 - the schemes that were proposed to monitor these two gases were not reliable and were very costly. Therefore, the Navy decided to use gas chromatography and undertook development of the Mark V atmosphere analyzer, a gas chromatograph.

The Mark V was the most unreliable atmosphere analyzer

ever used in the Navy. By the end of the 1960's the Mark V was experiencing downtimes in excess of 90%. The maintenance cost had become prohibitive. Some remedial action was clearly needed. The first approach was to revert back to the multiple type of instruments used on the Mark II-IV. Improved infrared sources and detectors were developed for the Mark VI atmosphere analyzer. The Mark VI, however, experienced immediate problems upon introduction to the Fleet and was not as reliable as the Mark IV.

Therefore, the Navy reconsidered mass spectrometry. Mass spectrometry had undergone a great metamorphosis in the late 1960's, mainly due to the space program. Instruments had been developed which were small, rugged, and reliable. Moreover, mass spectrometers that could operate for months without any attention had been demonstrated. NRL, which had an active mass spectrometry research program for more than 10 years, proposed a program which used mass spectrometry as the technique to analyze submarine atmospheres.

II. PROJECT "UPTIGHT" - The First Submarine Mass Spectrometer Analyzer

The first routine mass spectrometer analysis at sea used a mass spectrometer built for NASA by Perkin-Elmer Aerospace. The instrument was obtained from NASA, modified

and installed on a submarine in less than a month. Because of this very tight time schedule, the name "Uptight" was given to the program. The unit was installed aboard the USS HAMMERHEAD (SSN 663) by Mr. R. S. Olfky of NRL who made an initial five day voyage to observe the operation of the instrument and to train the crew to use the instrument. The "Uptight" unit was deployed on the HAMMERHEAD for a long sea trial. During this sea trial the "Uptight" unit operated continuously for 71 days and gave readings which agreed with the portable analyzing equipment and known atmospheric trends in the submarine such as CO₂ response to the ship's ventilation periods. The reason portable analytical readings were used to compare with the "Uptight" data is that the Mark V atmosphere analyzer failed the day that the HAMMERHEAD left port and could not be repaired at sea. It is worth noting that the Mark V had been overhauled just prior to the HAMMERHEAD's departure.

"Uptight" required no helium, no calibration gas or other unique consumables, and, with the exception of one flowrate adjustment, no maintenance, calibration or other operation actions. The flowrate adjustment consisted of operating a single throttle valve to reestablish the specified sample rate.

On the day prior to entering port the sample transport pump of the "Uptight" instrument failed. Since the pump was not part of the "Uptight" instrument, but only a temporary installation, this failure caused no major concern.

The "Uptight" mass spectrometer monitored four gases - nitrogen (N_2), oxygen (O_2), carbon dioxide (CO_2), and water (H_2O). The concentration readings were displayed on four digital voltmeters. In addition, the instrument was equipped with a multipoint switch which could be changed so that instrumental operating parameters, such as total pressure and electron accelerating voltage could be measured.

The basic assumptions made in calculating the partial pressures of N_2 , O_2 , CO_2 , and H_2O were that the atmosphere contained 1% argon and that the fragmentation patterns of the four gases were constant. These assumptions were valid; the argon concentration was independently measured to be 0.96% and as noted above, the CO_2 concentration correlated well with changes expected during surface ventilation and the operation of the CO_2 scrubbers. In addition, the H_2O readings agreed well with the partial pressures of H_2O calculated from the relative humidity readings. The O_2 concentration measured on the ship's portable oxygen analyzer also agreed well with the mass spectrometric readings and the variations in the sum of the partial pressures of the

four constituents correlated with the fluctuations in the ship's barometric readings. Moreover, the instrument was unaffected by any mechanical vibrations in the ship. As an accuracy check of the mass spectrometer analyzer, a sample was taken of the submarine's atmosphere and returned to NRL for detailed laboratory analysis. The results of the analysis are shown in Table 1 and are compared with analysis obtained at sea on the HAMMERHEAD. It was concluded that during this test the mass spectrometer had performed reliably and accurately.

It is worth noting the difference between the "Uptight" mass spectrometer atmosphere analyzer and other Navy atmosphere analyzers. Such a comparison is made in Table 2. As can be seen the most serious deficiency of the mass spectrometer was its inability to detect CO and the refrigerant gases, R-11, R-12, and R-114. Thus, the "Uptight" instrument measured only two of the five gases measured by the Mark III, IV, V, and VI atmosphere analyzers. The measurement of the refrigerant gases is important since they can decompose when they pass through the catalytic burner on the submarine and generate corrosive and toxic vapors. As noted above, the mass spectrometric detection of trace amounts of carbon monoxide is difficult because CO and N₂ have almost the same mass. This failing is not unique to

the "Uptight" instrument. Before a mass spectrometer was considered seriously as a submarine analyzer, the "Uptight" deficiencies had to be removed. These changes involved mainly the monitoring of different masses than were possible with the "Uptight" instrument.

The crew of the HAMMERHEAD also concluded that the "Uptight" instrument was not a direct replacement for the Mark V atmosphere analyzer. However, the HAMMERHEAD's crew noted that with the addition of the refrigerant gases, CO, and possibly total hydrocarbon channels, the "Uptight" unit would be clearly superior to the Mark V analyzer in all respects (Refs. 1,2, and 3).

After reviewing the data obtained on the HAMMERHEAD sea trial NRL recommended that the "Uptight" instrument be modified to monitor the refrigerant gases and CO, and that the modified unit be considered as a replacement for the Mark V analyzer (Ref. 4). This was the birth of the CAMS-I program.

III. THE CAMS-I PROTOTYPE UNITS - PROJECT "TOO TIGHT"

After the successful completion of Project "Uptight" a crash program was instituted by the Navy and NASA to develop an atmosphere analyzer based on mass spectrometric principles. The urgency of this program and pressures to develop a satisfactory unit earned the project the name "Too Tight." The program was awarded to the Aerospace Division of Perkin-

Elmer Corp. in March 1971 and the first delivery was scheduled in November 1971. However, an inspection visit to Perkin-Elmer in November of 1971, indicated that the prototype CAMS-I instrument was not ready for shipboard installation (Ref. 5). In addition, the first CAMS-I prototype still could not detect CO. Therefore, NRL agreed to supply a laboratory CO detector so that the ship would be able to monitor CO during the first test cruise. NAVSEC decided that the prototype would be installed as scheduled on the USS PINTADO (SSN 672), under the command of CDR George Holland. In order to expedite the shipboard installation of the CAMS-I unit, CDR Holland agreed to allow the prototype to be installed onboard the PINTADO for its final testing during a short shake-down cruise of the PINTADO in December of 1971, provided a NRL representative went along on the cruise.

Accordingly, Mr. R. S. Olfky of NRL, Mr. Larry Stuart and Mr. B. Bickslar of Perkin-Elmer, went aboard the PINTADO on November 26th to install the CAMS-I unit which was subsequently tested at sea. A Mine Safety Appliance Corporation Lira CO detector from NRL was used during this cruise as the CO detector. The mass spectrometer portion of the CAMS-I performed admirably. The Lira gave the only detector problems of this cruise. First, the Lira's amplifier

became sluggish; this problem was easily resolved by replacing an electron tube in the amplifier. Then the Lira exhibited an unrelated response to the rolling and pitching of the PINTADO during dive, rise and roll exercises. On the basis of these results, NRL reported that the Lira was not satisfactory for a permanent installation on a submarine and recommended that a permanent CO detector be developed and incorporated as part of the CAMS-I unit as soon as possible.

The results, other than CO measurements, obtained on this short sea cruise were in excellent agreement with other measurements taken with the ship's portable instrumentation. In addition, the atmospheric trends observed for CO₂ concentration were those expected from the normal operation of the ship. Therefore, NRL recommended that the CAMS-I unit be considered as a replacement for the Mark V atmosphere analyzer previously used on the PINTADO. As a result of the NRL recommendation, NAVSEC certified that the CAMS-I equipment was ready for OPEVAL (operational evaluation) and requested concurrent TECH/OPEVAL of the CAMS-I (Ref. 6).

In March of 1972, the second CAMS-I prototype was installed on the USS HAWKBILL (SSN 666). The installation was again supervised by Mr. R. S. Olfky and who also instructed the crew in the operation of the prototype. The installation was normal and very similar to that reported

for the PINTADO above.

The major difference between the prototype installed on the PINTADO and that on the HAWKBILL was the development of a new CO detector. This detector, developed by Andros, Inc., is a dual isotope fluorescence nondispersive infrared detector. It uses fluorescence of CO to produce infrared radiation that is an exact match to the infrared absorption of atmospheric CO. A schematic of the detector is shown in Figure 1. A broad band infrared source stimulates fluorescence radiation in a CO mixture containing 50% of ^{12}C and 50% of the ^{13}C isotopes sealed in a fluorescence cell. The fluorescence radiation passes through one of two filter cells mounted in a rotating chopper wheel. One filter contains CO with only the ^{12}C isotope and the other filter contains CO with only ^{13}C . Each filter cell when inserted in the optical path will absorb only radiation which originated from CO containing the same isotope as in the filter. This results in a single beam of infrared radiation with alternating pulses of ^{12}CO and ^{13}CO radiation of equal intensity. The pulses alternately pass through the sample chamber. Any particulate matter or moisture present in the sample or accumulated on the optical windows attenuates both pulses equally and hence does not affect the analysis. Since ~99% of all naturally occurring carbon monoxide is ^{12}CO , the

^{13}CO pulse is not significantly absorbed by the CO in sample gas and is used as an internal reference after appropriate electronic correction. The ^{12}CO and ^{13}CO signals are compared after passage through the sample chamber and the concentration of CO in the sample is measured. This method does not require the use of a calibrating gas. On the basis of exhaustive tests (Ref. 7) NRL concluded that the dual isotope fluorescence CO detector was reliable, accurate and interference free. NRL recommended that it be installed in the CAMS-I units as quickly as possible.

After completion initial tests upon the PINTADO the CAMS-I unit was removed from the PINTADO and shipped to NRL for its technical evaluation tests (Ref. 8). In addition, detailed tests were undertaken to determine the response time of the CAMS-I on board the HAWKBILL. Response time is defined as the time that it takes the CAMS-I to indicate 90% of the value of a contaminant when that contaminant is released in the submarine's atmosphere. Tests were made to determine the response time of gas from the various compartments of the submarine to the analyzer. These results are shown in Table 3. The consistency of the analysis results obtainable on a CAMS-I from the various compartments can be seen in Table 3. Since the physical flow system of CAMS-I affected both the CAMS-I response time and the

pressure drops, a schematic of the plumbing arrangement used for this installation is shown on Figure 2. Some relative total pressure readings and the pressure changes in the CAMS-I are given in Tables 3 and 4. The response times from sampling ports to analyzer of various Navy atmosphere analyzers are reported in Table 5 and compared with those obtained from the CAMS-I shown in Table 6. Unless noted otherwise all data are taken using the calibration mixture containing R-11 and R-12. The connection from the calibration gas cylinder to the port terminated in a tee connection so that the pump reading was constant. It is apparent from the data presented in Table 6 that neither the change of filters in mass spectrometry porting, nor the tuning of the instrument had an appreciable effect on the response times. It is also apparent that the response time of the HAWKBILL unit is significantly longer than the response time of the PINTADO unit. The reason for the different response times undoubtedly lies in the flow system of the PINTADO's unit.

Several comments are necessary in order to compare the response time results based upon data obtained from the Mark III analyzer on board the USS SCULPIN (SSN 590) and the Mark VI on board the USS GUITARO (SSN 665) (Table 5) with the data obtained from CAMS-I units on board the PINTADO and HAWKBILL (Table 6). First, the Mark III on board the

SCULPIN is not located in the same position as the analyzer on board the HAWKBILL and PINTADO. Therefore, only a limited comparison of the response times for the various positions in the ship can be made. Secondly, the Mark III on the SCULPIN was completely shut down when NRL representatives arrived to measure the response times. This meant an eight-hour wait before the Mark III could be put into operation. Thirdly, when the Mark III is in standby mode, several steps are required before any readings can be made. These include the hand priming the transport pump, evacuation of all Mark III channels, zeroing all channels, and finally turning on the instrument's transport pumps. These operations take approximately 4 minutes. Therefore, 240 seconds should be added to all times measured for the Mark III. In addition, if the concentrations being measured are to be valid, additional time must be spent in introducing a calibrating gas and calibrating each of the channels of the Mark III.

The Mark VI on the GUITARO was located in the same place as the monitors on the HAWKBILL and PINTADO. Therefore, a better comparison of the response times can be made. For response time measurements to be made on the Mark VI, the channels first must be zeroed by passing nitrogen into the channels and making appropriate adjustments. This procedure requires about one minute, thus, 60 seconds should be added to the Mark VI measurements shown in Table 5. In

addition to the nitrogen zero gas, the Mark VI, like the Mark III, requires the use of calibration gas before reading the various channels. Nonetheless, the response times of the Mark VI were very fast compared to the CAMS-I values.

No Mark V atmosphere analyzer response time measurements were made because the Mark V is a gas chromatograph. Therefore, the sample is not introduced to this instrument continuously, but by a batch method in which a portion of the gas is "cut" from the gas stream and introduced into the Mark V. It is impossible to measure the time required for gas to travel from the submarine compartments to the gas sampling valve, because the Mark V has no method of sensing when the sample arrives at the selector valve. Finally, since the Mark V is a gas chromatograph, the time required for analyses is approximately 15 minutes making the Mark V inherently slower than the Mark III, IV, VI, and the CAMS-I. The Mark V like the Mark III and Mark VI and Mark IV requires the use of zero gas and calibration gas before valid data can be obtained.

As part of the operational test and evaluation program of the CAMS-I, 19 evacuated flasks were left with the crew to take atmospheric samples. Fifteen of the sample flasks were returned in condition suitable for analysis. The

results compared with the data obtained for readings on the HAWKBILL during the operational evaluation. The data obtained from this comparison are given in Table 7.

The NRL analyses, except for the CO data, were obtained on a modified, CEC 21-103C mass spectrometer designed for gas analysis. The NRL CO determinations were made with the Mine Safety Appliance Company, Lira CO detector used on the early PINTADO CAMS-I. This is a standard nondispersive infrared detector. It is subject to many interferences and believed to be less accurate than the Andros CO detector used on board the CAMS unit. Argon is a significant atmospheric component and it is not monitored with the CAMS-I. Therefore a correction of the data obtained by CAMS-I is required.

In the CAMS-I, 1% of the total pressure transducer reading is fed into a summing circuit and an appropriate correction of each constituent monitored is automatically made. Mathematically the circuit performs the following operation:

$$R_i = P_i - \frac{P_i}{T.P.} (0.01 \times T.P.);$$

where R_i is the electrical signal observed on the CAMS-I for the pressure of the i th component; P_i is the electrical signal of the i th component before the summing circuit

correction; and T.P. is the electrical signal observed for the total pressure transducer reading. Equation 1 assumes the atmospheric argon correction to be 1%, thus, if argon is not present in the atmosphere the pressures read on the CAMS-I will be too low. While if the argon concentration is greater than 1% the Mark I readings will be too high. Readings from the Mark I are presented in Table 7, with the argon concentrations measured at NRL. As can be seen from comparison of the results shown in Table 7, the argon concentration does not significantly differ from the assumed 1%.

The results of the operational and technical evaluations were very successful (Ref. 9) and the unit was classified as service approved. The final report from the Commander of the Operational Test and Evaluation forces (COMOPEVFOR) stated (Ref. 10) that the Central Atmosphere Monitoring System, Mark I, for a total of 13 months, was able to provide consistent readings on the calibration gases. The report also stated that there was a need for better calibration gases. Table 8 compares the CAMS-I analysis of some calibration gases to laboratory analysis of the same gases. Minor discrepancies are apparent. The explanation for these differences is not known. However, CAMS-I exceeded the acceptance criteria of the performance

specifications. The COMOPEVFOR report (Ref. 10) states that the CAMS-I demonstrated a unique reliability and consistency of measurements and the ability to provide timely indication of the change in atmosphere. It is greatly superior to existing submarine atmosphere analyzers. With this recommendation, Perkin-Elmer Corporation was awarded a contract to build production units of the CAMS-I. The CAMS-I is installed now on more than 30 nuclear submarines. The instruments have proven to be extremely reliable and satisfactory. The only major problem that has developed in the production units was the adjustment of the leak valve. This problem was solved by a minor change.

Figure 3 is a photograph of the CAMS-I unit now being installed on submarines. As previously stated, this unit consists of a dual isotope fluorescence nondispersive infrared spectrometer to monitor carbon monoxide and a fixed collector mass spectrometer to monitor hydrogen, water, nitrogen, oxygen, carbon dioxide, refrigerant-12, refrigerant-11 or refrigerant-114. Figure 4 shows a schematic of the CAMS Mark I analyzer.

IV. THE CAMS-II

Since the CAMS-I has proven to be such an outstanding atmosphere monitor (9) the question may well be asked "Why do we need another development and another instrument?" The

answer is that the CAMS-I, because of its fixed collectors in the mass spectrometer can only monitor 8 preselected contaminants. There are two analytical instruments which can provide the needed versatility, a scanning infrared spectrometer and a scanning mass spectrometer. The former instrument lacks the sensitivity to serve as a trace contaminant detector. The mass spectrometer however, has sensitivity sufficient for trace analysis and at least in theory can be used to identify all the constituents in a submarine atmosphere. As noted previously, scanning mass spectrometers had previously been considered for submarine atmosphere monitors, but were rejected because of their fragile nature and copious amount of data they generate. It was felt that these factors would make the instrument useless at sea. However, technology has produced mass spectrometers, which are rugged, small, highly reliable and the data they generate can easily be interpreted by a modern mini-computer or micro-processor. Therefore, a mass spectrometer controlled by a computer is potentially an ideal analyzer for nuclear submarine atmospheres. Furthermore, this system has the potential to control and operate other ship-board devices.

The development of a computer-controlled atmosphere analyzer is the second phase of the Navy's CAMS program,

namely the CAMS-II. In the CAMS-II CO is still monitored by an infrared spectrometer, but the heart of the instrument is a scanning mass spectrometer. The CAMS-II continuously monitors 12 preselected components and like the CAMS-I activates an alarm system if out of tolerance conditions exist for any of the compounds being monitored. The analytical scheme does not attempt to identify the various hydrocarbons, but rather "characterizes" them by the following technique. The ion current intensities at masses 43, 57, 85, 99, and 113 are summed to give an indication of the aliphatic hydrocarbon concentration. The sum of the ion currents of masses 91, 105, 119, 133, and 147 is an indication of the aromatic hydrocarbon concentration, and mass 78 ion current intensity is the measure of the benzene concentration. Thus, the important information, which is impossible to obtain with the present submarine analyzer can be obtained from the CAMS-II. Any new constituent may be added or deleted from the compounds being monitored by only a program change. Finally, a complete mass spectrum is recorded every hour on a magnetic disc (or some other device) and these records will provide the Navy with accurate information for future medical studies on the long term effects of atmospheres on submariner's health. Figure 5 depicts how the CAMS-II could be packaged when it is completely developed.

The ability to monitor trace contaminants in the atmosphere using mass spectrometry depends upon a variety of factors. The most important is how unique is the mass spectrum, i.e., are there intensities at masses which are not part of the background? For instance, most hydrocarbons produce an intense peak at mass 43 ($C_3H_7^+$), i.e. $C_xH_y + e^- \rightarrow C_3H_7^+ + C_{x-3}H_{y-7} + 2e^-$. Thus, a signal at mass 43 is probably due to a hydrocarbon; however, it gives virtually no information as to the specific identity of the hydrocarbon. Also, other molecules do produce an ion at mass 43, for instance acetone. In order to evaluate the ability of mass spectrometry to monitor trace constituents, a laboratory mass spectrometer has been constructed at NRL. Certain aspects of the design were chosen to be similar to the mass spectrometer system used in CAMS-I.

The mass spectrometer system shown in Figure 6 consists of a quadrupole mass filter placed within a small vacuum chamber. The vacuum chamber is pumped with a 20 liter/sec ion pump. A leak valve virtually identical to the one used on CAMS-I is connected to the vacuum chamber. With the leak valve closed, the pressure in the chamber is less than 10^{-8} torr (10^{-11} atm). During sampling, the valve is adjusted so that the pressure is 2×10^{-6} torr. This pressure is

sufficiently low that the ion pump should be able to operate for two years before needing new elements.

The mass spectrometer electronics have been interfaced to a mini-computer data system. Thus, the mass spectrometer can be controlled automatically. Various programs for attaining data and analyzing it can be tested. All of the programs are written in a high-level language, FORTRAN, and are therefore straightforward to understand and modify. For example, the data system can automatically calibrate the mass scale by finding the peaks corresponding to the water and carbon dioxide (masses 18 and 44, respectively). Naturally these peaks will always be present. From the position of these peaks it can determine the position of all other peaks from mass 2 to 200. It was found that this procedure was accurate over the mass range of 2-200 to ± 0.1 mass unit. Since the instrument is operated such that the mass peaks are 0.3 mass units wide, this accuracy is sufficient.

The sensitivity of the system to various contaminants has been determined. Mass spectra were recorded of two calibrated mixtures of typical atmospheric contaminants. A summary of these results is given in Table 9. With no air admitted to the system, the ion current intensities were all zero. The column in Table 9 labelled background is the ion

current intensity when the CAMS-II is sampling clean air (ion pump pressure $\sim 2 \times 10^{-6}$ torr). The columns in Table 9 labelled 10 ppm and 100 ppm represent the intensity when mixtures of 10 ppm and 100 ppm are sampled. Each mixture contained 10 ppm and 100 ppm respectively of the following: R-12, R-113, R-114, methane, carbon monoxide, vinylidene chloride, trichloroethylene, methyl chloroform, hexane, benzene, and toluene.

Using data from Table 9, one can infer sensitivity limits for various gases. For benzene, 1 ppm is readily detectable. Greater than 200 ppb of total refrigerant gases were observable using mass 85; however, specification of a particular one would probably require 3-5 ppm. Certainly all of the species, except toluene, produce sufficient intensity to be identified at the 10 ppm level. The low sensitivity to toluene compared to benzene is believed to be due to toluene condensing on surfaces prior to entering the vacuum system. This is surprising, since the leak valve was heated to 80°C and the gas sampled was flowing through the leak valve at 500 cc/min. Another unexplained phenomenon is the background intensity. As can be seen from Table 9, column BGRD, the ion current intensity increases with increasing mass. One explanation would be that this phenomenon is due to photons striking the electron

multiplier. The photons could be produced by collisions of the ions with the quadrupole rods. At higher mass, the increased RF and DC fields of rods would produce more photons. It has to be assumed that the photons are reflected from various surfaces onto the multiplier. The evaluation of the laboratory CAMS-II unit is not completed yet.

In order for the CAMS-II unit to identify a variety of atmospheric constituents it must compare mass spectra it obtains to some type of library of mass spectra. A variety of schemes of library searches (Ref.11-13) have been developed over the last ten years. Most of them are designed to use individual mass spectra whereas the CAMS-II mass spectra will represent at best the sum of several spectra. Therefore, most of these methods are not suitable. One method has been developed specifically to analyze the mass spectra of mixtures and is called Probability Based Matching (Ref. 14).

In the PBM method the occurrence of a given peak in both the library mass spectrum of a compound and the unknown mass spectrum is weighted by a probability factor. The probability factor is based upon the probability that this peak will occur in an arbitrary mass spectrum. The sum of the probabilities for a given identification using the PBM method provides a straightforward way to assess the reliability of that particular identification. The PBM method

is now being evaluated for its effectiveness on the CAMS-II laboratory prototype. Presently we feel PBM is the method that will be used on CAMS-II.

V. THE FUTURE CAMS-IIB

We anticipate that after the CAMS-II has been completely developed, the CAMS-II computer will be used to control the entire life support system of the submarine. For example, it is unnecessary for crew personnel to observe on the CAMS-II that the oxygen concentration is too low and then start the oxygen generator to add more oxygen to the ship's atmosphere. Similarly for scrubbing CO₂, it should not be necessary to have to monitor the CO₂ concentration and then start the second CO₂ scrubber. Similarly the CAMS-II unit will be able to monitor the status of the carbon filter bed by monitoring the hydrocarbon concentration input and comparing it to the output concentrations and alert the crew when the carbon should be changed. This whole intergrated system, NRL calls the CAMS-IIB and it is shown schematically in Figure 7.

VI. ACKNOWLEDGMENT

The authors express their gratitude for the support, encouragement, and advice throughout the development of the submarine atmosphere analyzer program of our coworkers: Dr. Frank Ventriglio, Mr. Mike Littman, CAPT John Juergens, and

CAPT George Troffer of the Naval Sea System Command; Mr. P. H. Ross, and Mr. Paul Lipka of the Naval Ship Engineering Center; and Mr. R. S. Olfky, Dr. John Larkins and Dr. Frank Thomas of NRL.

REFERENCES

1. P. F. Carter, Jr., USS HAMMERHEAD ltr, SSN 663/03:DB/jig, 9650, Ser. 486 of 29 December 1970.
2. A. J. Whittle, Jr., Submarine Squadron 6 ltr, FCSS6/Ca, 9600 Ser. 40/111 of 26 January 1971.
3. E. P. Wilkinson, USS HAMMERHEAD ltr, 9600/SSN 663, Ser. N402A/1285 of 24 February 1971.
4. F. E. Saalfeld, NRL ltr rpt 6110-17:FES:vmg, Ser. 338 of 15 January 1971.
5. F. E. Saalfeld, NRL ltr rpt 6110-546:FES:vmg of 24 November 1971.
6. P. H. Ross NAVSEC ltr 6151C, Ser. 107DTD of 29 February 1972.
7. C. H. Blachly, R. S. Olfky, and F. E. Saalfeld, NRL ltr rpt 6110-138:FES:bh of 27 March 1973.
8. F. E. Saalfeld, NRL ltr rpt 6110-60:FES:vmg of 11 February 1972.
9. C. H. Brown, USS HAWKBILL ltr SSN 666/OKE:gn, 3930, Ser. 177, of 28 May 1972.
10. M. D. Carmody, COMOPTEVFOR ltr, 421:bt, 3930 Ser. 269 of 5 April 1973.
11. P. V. Fennessey, "Mass Spectrometry: Techniques and Applications," Wiley-Interscience, New York, NY, 1971.
12. R. G. Ridley, "Biochemical Applications of Mass Spectrometry," John Wiley, New York, NY, 1972.
13. S. L. Sasaki, "Determination of Organic Structures by Physical Methods," Vol. 5, F. C. Nachod and J. J. Zuckerman, Eds., Academic Press, New York, NY, 1973, p. 285.
14. Pesyna et al., Anal. Chem. 48, 1362 (1976).

Table 1

Comparison of Analysis Results Obtained on the "Uptight"
Unit Aboard the USS HAMMERHEAD and Those Obtained at NRL

Constituent	HAMMERHEAD sample 10/1/70-16:48 hrs Atmosphere Analyzer Results (%)	NRL Analysis (%)
H ₂ O	1.14	--*
N ₂	77.33	78.9
O ₂	18.93	18.71
Ar	1.00 (assumed)	0.96
CO ₂	1.60	1.61

*Sample was taken in an evacuated stainless steel cylinder and in all probability the H₂O was adsorbed on the walls of this container.

Table 2
Comparison of the Capabilities of
Submarine Atmosphere Analyzers

Constituent	Mark III	Mark IV	Mark V	Mark VI	THCA*	Uptight	CAMS-I	CAMS-II
H ₂	X	X	X	X	-	X	X	X
CH ₄	-	-	-	-	X	-	-	X
CO	X	X	X	X	-	-	X	X
N ₂	-	-	X	-	-	X	X	X
O ₂	X	X	X	X	-	X	X	X
CO ₂	X	X	X	X	-	X	X	X
Total Aromatic HC	-	-	-	-	-	-	-	X
Total Aliphatic HC	-	-	-	-	X	X	-	X
Benzene	-	-	-	-	-	-	-	X
R-11	X	X	X	X	X	-	-	X
R-12	X	X	X	X	X	-	-	X
R-113	-	-	-	-	X	-	-	X
R-114	X	X	X	X	X	-	-	X

X indicates the instrument is capable of analyzing for a given constituent.

* THCA is the total hydrocarbon analyzer; it is a gas chromatograph and uses a back flush technique to determine the total hydrocarbon content.

TABLE 3
Analysis Data, taken on CAMS-I, showing transit times from various compartments in the HAWKBILL

Submarine Compartment	Ambient Press (torr)	Total Time to Obtain Equilib. Reading on CAMS-I (sec)	Constituent:					
			CO(millitorr) transit time (sec)	H ₂ (torr) transit time (sec)	O ₂ (torr) transit time (sec)	CO ₂ (torr) transit time (sec)	R-114 (millitorr)	R-12 (millitorr)
Bow	752	197	35.1 (20)	---	157	10.9 (25)	56	52
Crew's Mess	755	150	38.9 (45)	7.5 (105)	160	11.7 (130)	70*	63
Bat. Supply	758	426	37.5 (67)	6.9 (142)	158	11.1 (142)	53	60
Bat. Exhaust	759	660	34.5 (30)	6.4 (120)	159	10.1 (120)	49	49
Fan Room				no data				
AMR #1 CO ₂ Scrub.	760	195	39.1 (45)	7.2 (76)	168	12.0 (76)	65	60
Engine Rm., Up. Lev.	740	213	38.3 (58)	7.1 (121)	165	11.6 (121)	56	57
Engine Rm., A/C Plant	804	206	38.4 (64)	7.1 (130)	168	11.8 (130)	58	60
AMR #2, Up. Lev.	746	256	37.6 (60)	6.9 (120)	156	10.9 (131)	51	56
AMR #2 CO ₂ Scrub.	745	200	38.1 (58)	6.9 ---	155	10.9 (122)	55	59
AMR #2 Ships Store Plant	806	198	38.3 (45)	7.2 (120)	169	12.0 (120)	59	62
Reactor Comp.	812	300	38.8 (18)	7.2 (86)	152	11.1 (86)	60	61

*R-11 was read for this test instead of R-114.

Table 4

Pressure Variations Aboard HAWKBILL

Sampling Location	P_{XD} Output (torr)	ΔP Rel to Mark I Ambient
1. Bow Compartment	754	-10
2. Crew's Mess	758	- 6
3. Battery Supply	754	-10
4. Battery Exhaust	745	-19
5. Fan Room	752	-12
6. AMR #1 - CO ₂ Scrubber	756	- 8
7. Engine Room	746	-18
8. Engine Room - A/C Plant	749	-15
9. EMR - UL	750	-14
10. EMR - CO ₂ Scrubber	748	-16
11. AMR - Ships Stores Plant	750	-14
12. Reactor Compartment	752	-12

P_{XD} = pressure at sampling location

Table 5

Response Times of the MK-III (SCULPIN, 590) and the
MK-VI (GUITARRO, 655) Atmosphere Analyzers

a. Gas introduced at the calibration part of the instrument.

Constituent	MK-III		MK-VI	
	Initial Response (sec)	Stabilized Reading (sec)	Initial Response (sec)	Stabilized Reading (sec)
R-12	30	110	R-12 channel inoperative	
CO	50	150	10	30
CO ₂	80	150	10	30
H ₂	80	150	10	30
R-11	-	-	10	30

b. Gas introduced at position #1 of the submarine compartment selector valve:
the torpedo room in SCULPIN; the bow compartment in GUITARRO.

R-12	45	195	R-12 channel inoperative	
CO	95	305	18	60
CO ₂	110	390	15	75
H ₂	180	230	10	45
R-11	-	-	30	75

Table 6
Response Times

Ship	Gas	Time needed for initial detection (sec)	Time needed to obtain a stable reading (sec)	P _{am} T	CO MT	H ₂ T	O ₂ T	CO ₂ T	R11 MT	R12 MT	N ₂ T
HAWKBILL (no changes in Mk-I)	CO CO ₂ /H ₂	20 160	170 270	766	32	5.7	161	9.4	54	52	575
HAWKBILL, now filter installed in the Mark-I	CO CO ₂ /H ₂	15 145	175 275	766	41	7.1	161	12.0	72	67	-
HAWKBILL, new filter installed m.s. tuned	CO CO ₂ /H ₂	18 140	185 225	766	40	7.1	160	12.1	73	68	574
HAWKBILL, new filters installed m.s. tuned 2nd filament	CO CO ₂ /H ₂	20 132	185 240	766	40	6.7	160	12.0	76	68	572
HAWKBILL, new filters installed m.s. tuned 1st filament	CO CO ₂ /H ₂	17 135	170 235	766	40	7.0	160	11.6	71	66	575
PINTADO	CO CO ₂ /H ₂	10 58	110 155	761	41	5.6	157	8.5	48	53	573
PINTADO, run with calgas from cyl. #30205	CO CO ₂ /H ₂	10 75	105 145	762	41	6.3	158	10.7	65 ^a	59	575
PINTADO, run with calgas from cyl. #30205	CO CO ₂ /H ₂	- -	- -	762	-	-	-	-	10 ^b	168	-

a. R-114 was measured in this analysis.
b. The refrigerant gas switch was changed from measuring R-114 to R-11; note the change in the R-12 concentration.

Table 7

Comparison of CAMS-I and Laboratory Analysis of HAWKBILL
Atmosphere Samples and Calibration Gases

Sample	H ₂ (%)	H ₂ O (%)	N ₂ (%)	CO (PPM)	O ₂ (%)	Ar (%)	CO ₂ (%)	R-12 (PPM)	R-11 (PPM)
No. 1, 4/12/72 Upper Level OPS									
NRL	0.14	-	77.6	16	20.6	1.1	0.96	21.9	10.1
Mark I, 1000 ^a	0.15	1.75	76.6	12.5	19.9	1 ^b	0.92	22.2	12.6
No. 2, 4/27/72 R.C.U.L.									
NRL	0.16	-	72.7	24	20.3	1.0	0.97	44	<1
Mark I, 1200 ^a	0.15	1.6	72.3	24.8	20.3	1 ^b	0.95	57	0
No. 3, 5/3/72 Batl Exh 0110									
NRL	0.25	-	77.3	2.5	20.2	1.0	1.11	36	<1
Mark I, 0100 ^a	0.5	1.6	76.2	2.5	20.9	1 ^b	0.97	40.7	1.3
No. 4, 5/12/72 AMR No. 2									
NRL	0.18	-	76.9	27	21.7	1.0	1.2	31.4	<1
Mark I, 1700 ^a	0.15	1.9	75.2	30	20.9	1 ^b	0.97	31.8	0
No. 5, 5/21/72 Bow Comp									
NRL	0.20	-	75.2	20	22.9	1.1	1.10	17.2	<1
Mark I, 1300 ^a	0.16	1.85	75.3	14	21.2	1 ^b	0.86	13	1.3

a. Mark I readings were apparently taken with the submarine compartment selector valve set to the fan room position and not to the compartment where the sample was taken. Therefore readings represent an integrated value of the submarine's atmosphere.

b. Argon concentration assumed to be 1%.

Table 7 - Cont'd.

Comparison of CAMS-I and Laboratory Analysis of HAWKBILL
Atmosphere Samples and Calibration Gases

Sample	H ₂ (%)	H ₂ O (%)	N ₂ (%)	CO (PPM)	O ₂ (%)	Ar (%)	CO ₂ (%)	R-12 (PPM)	R-11 (PPM)	R-114 (PPM)
Cyl 15950										
NRL	1.2	-	74.6	45	20.8	0.96	1.4	71.8	-	65.3
Manuf.Anal	1.05	-	77 ^a	45	20.4	-	1.35	64	-	64
Mark I	1.05	2.46	75.8	56.9	20.6	1 ^b	1.36	72.4	-	62.3
Cyl 14717 (Pintado)										
NRL	0.9	-	73.2	44	20.2	1.06	1.42	74.7	67.3	-
Manuf.Anal	1.09	-	77.15 ^a	45	20.4	-	1.36	64	66	-
Mark I	1.16	0.49	75.7	46	20.3	1 ^b	1.33	73	70 ^c	-
Cyl 14827										
NRL	1.09	-	75.2	43	21.2	0.95	1.5	71	70	-
Manuf.Anal	1.10	-	78.5 ^a	45	20.4	-	?	66	68	-
Mark I	1.08	0.58	75.7	53.7	20.5	1 ^b	1.34	76.5	72.6 ^c	-
Cyl 3123 Hawkbill										
NRL	1.02	-	72.3	55	22.0	1.05	1.69	76.1	72	-
Manuf.Anal	1.06	-	77.2 ^a	44	20.4	-	1.33	66	65	-
Mark I	1.06	0.59	73.7	54.9	22.1	1 ^b	1.65	77	69	-
Cyl 31481										
NRL	1.08	-	74.1	52	20.4	1.05	1.63	66	-	70
Manuf.Anal	1.06	-	77.2 ^a	45	20.4	-	1.39	63	-	65
Mark I	0.92	0.64	75.9	49.9	21.0	1 ^b	1.50	78.8	-	73.6
Cyl 2805										
NRL	1.62	-	73.1	47	21.6	0.99	1.43	64	-	65
Manuf.Anal	1.04	-	77.3 ^a	47	20.3	-	1.38	65	-	64
Mark I	1.11	0.04	75.96	54	20.4	1 ^b	1.34	64.7	-	73.5
Cyl 17608										
NRL	0.9	-	73.9	51	21.7	1.0	1.5	70	-	68
Manuf.Anal	1.0	-	77.2 ^a	46	20.4	-	1.36	65	-	67
Mark I	1.1	0.19	75.8	54.2	20.4	1 ^b	1.35	76.4	-	72.8

a - Manufacturer does not analyze for N₂; value obtained by difference.

b - Argon concentration assumed to be 1%.

Table 8

Analysis Results of Samples of Calibration Gases
(Data taken aboard HAWKBILL)

Compound	Value of Laboratory Analysis	Value Determined on CAMS-I
A. Cylinder #31481		
O ₂	156.4 torr	160.0 torr
CO ₂	10.65 "	11.4 "
H ₂	8.12 "	7.0 "
R-12	48.3 millitorr	60.0 millitorr
R-114	49.8 "	56.0 "
CO	34.5 "	38.9 "
N ₂	--	578 torr
H ₂ O	--	4.9 "
B. Cylinder #3123		
O ₂	156.4 torr	157.0 torr
CO ₂	10.19 "	11.7 "
H ₂	8.13 "	7.5 "
R-12	50.6 millitorr	62.0 millitorr
R-11	49.8 "	70.0 "
CO	33.73 "	39.0 "
N ₂	--	523 torr
H ₂ O	--	4.2 "

Table 9
 Ion Current for Various Contaminants Determined in
 the Laboratory CAMS-II Prototype

MASS	BGRD	10 PPM	100 PPM	SPECIES
43	640	670	1570	Hexane
57	5	65	886	Hexane
61	4	115	1511	Vinylidene Chloride
78	15	62	796	Benzene
85	17	250	2582	R-12, R-113, R-114
92	8	10	87	Toluene
95	14	36	390	Trichloroethylene
96	15	44	535	Vinylidene Chloride
97	15	34	340	Methylchloroform
101	18	98	820	R-113, R-12
130	24	34	234	Trichloroethylene
135	30	53	450	R-114
151	32	46	324	R-113

100 ~5 x 10⁻¹⁶A

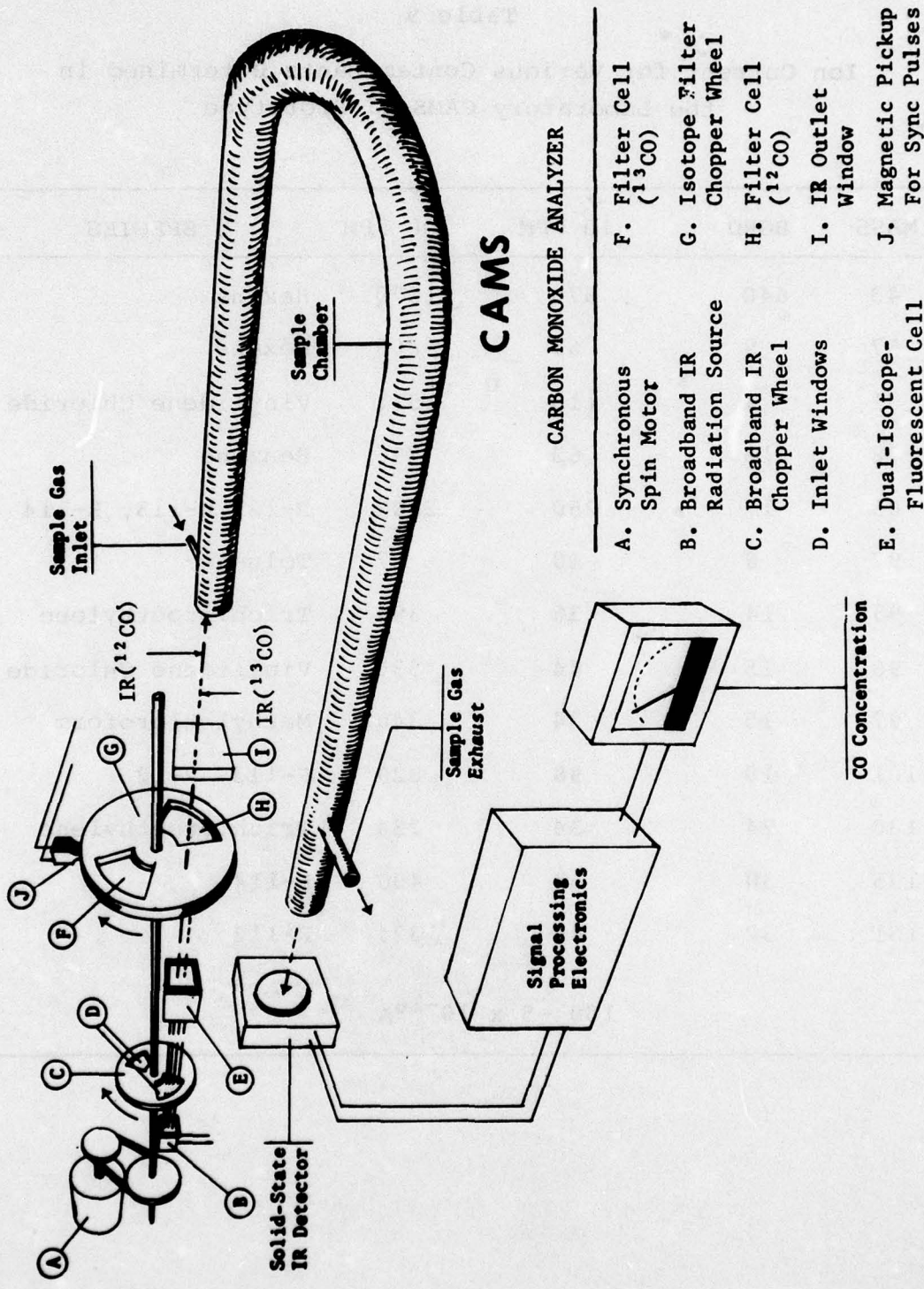

Fig. 1 — CAMS carbon monoxide analyzer

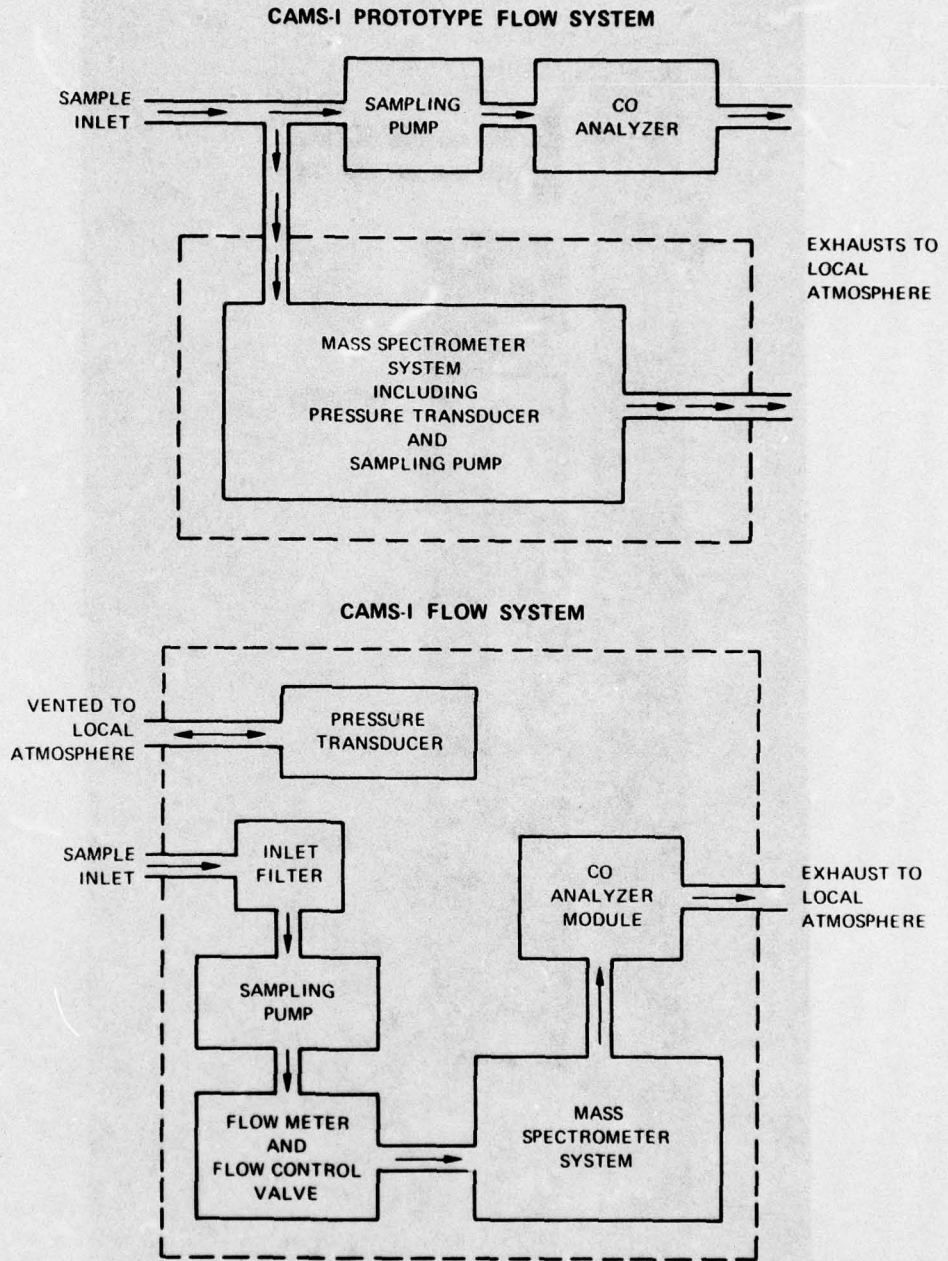

Fig. 2 — Plumbing arrangement for the prototype CAMS-I unit aboard the HAWKBILL and plumbing arrangement of production CAMS-I



Fig. 3 — The CAMS-I analyzer built by Perkin-Elmer Corporation

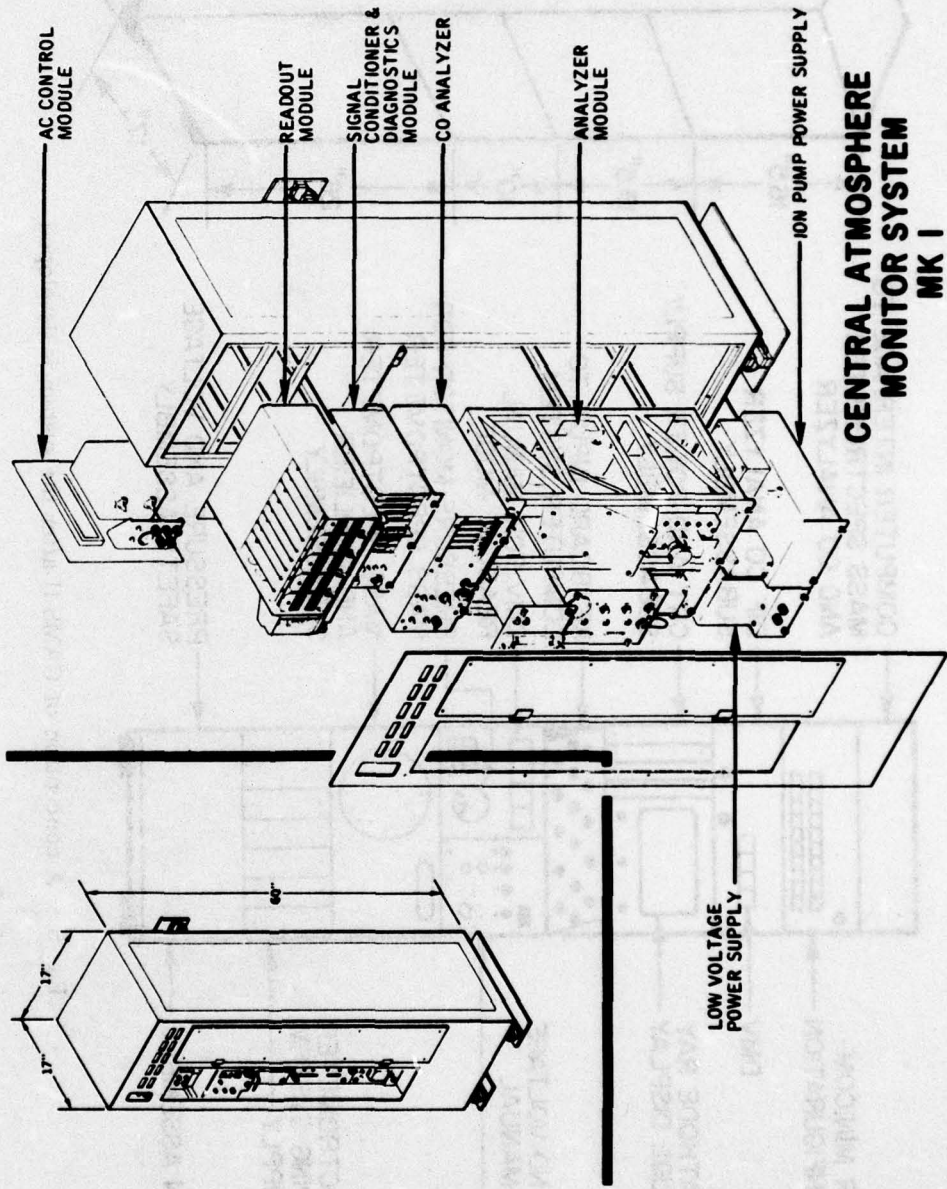

Fig. 4 — A schematic of the CAMS-I analyzer, showing the various components of the instrument

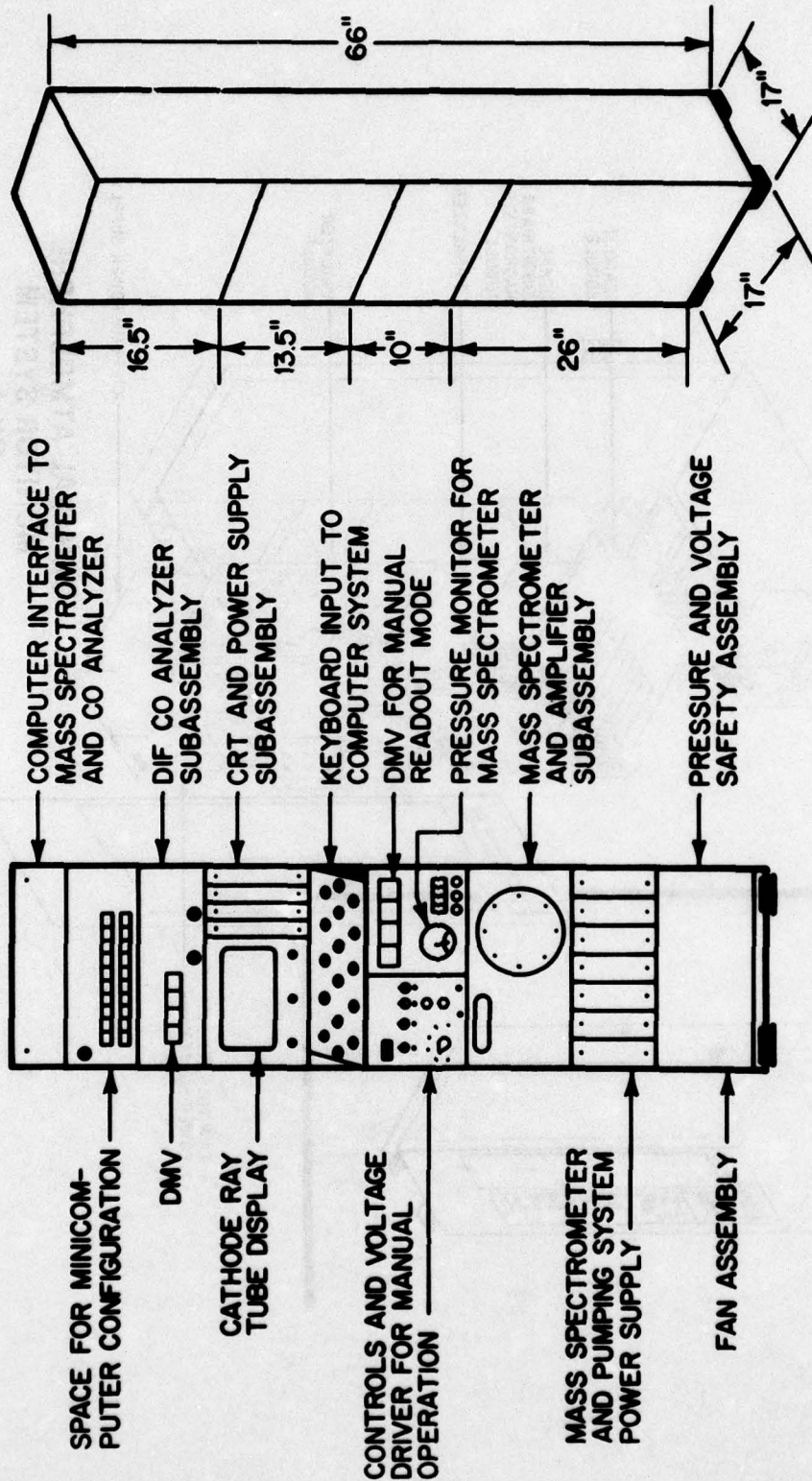

Fig. 5 - A conception of CAMS-II after the system is developed

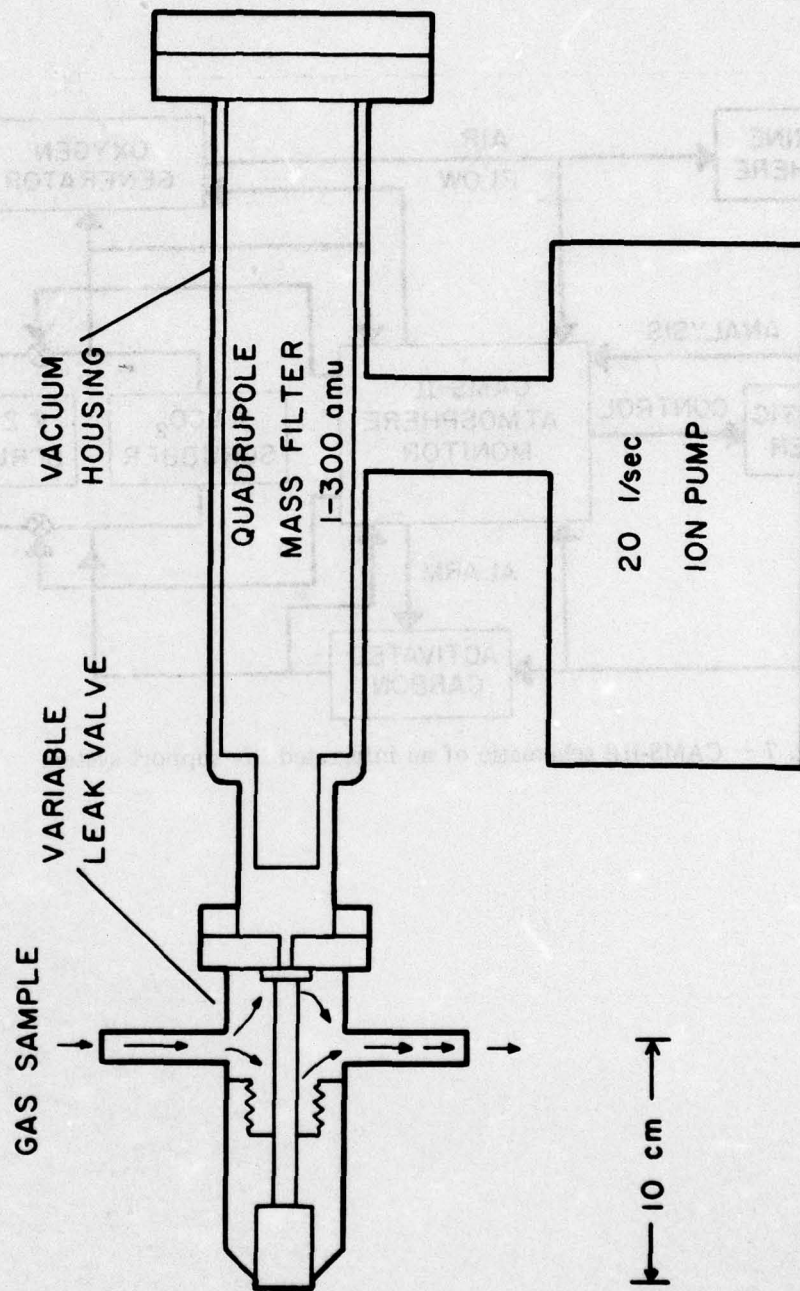

Fig. 6 - CAMS-II laboratory model

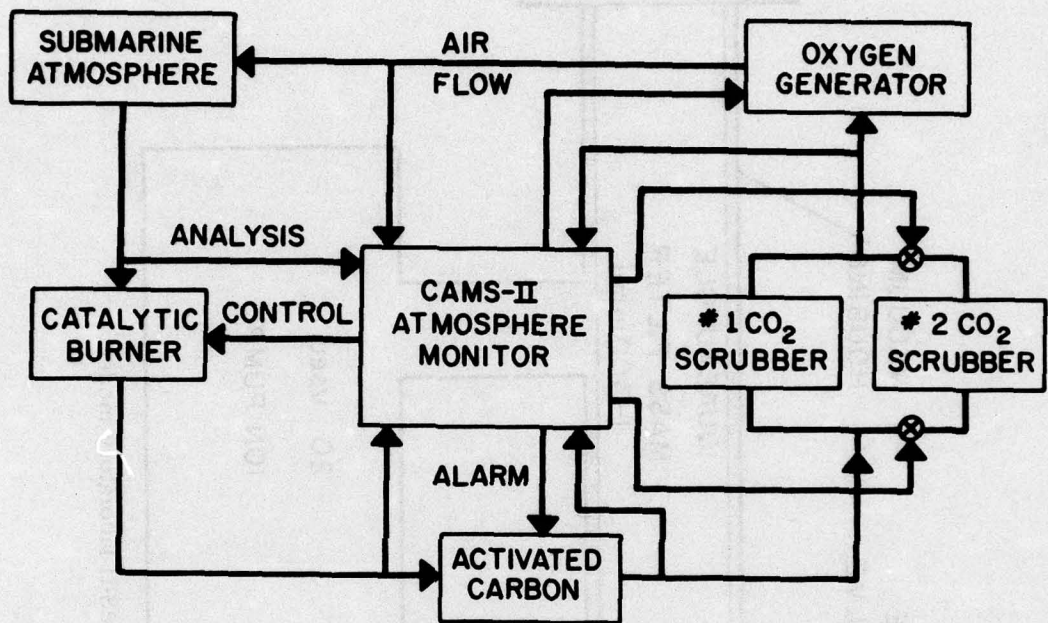

Fig. 7 - CAMS-IIB schematic of an integrated life support system