

AD-A035 801

CIVIL ENGINEERING LAB (NAVY) PORT HUENEME CALIF
A REMOTELY CONTROLLED INCREMENTAL SEAFLOOR CORER.(U)
NOV 76 M C HIRONAKA
CEL-TN-1462

F/G 13/9

UNCLASSIFIED

NL

1 OF 1
ADA035801



END
DATE
FILMED
3 - 77

ADA 035801

17
NW

Technical Note



TN no. ~~N-1462~~

title: A REMOTELY CONTROLLED INCREMENTAL SEAFLOOR CORER

author: M. C. Hironaka

date: November 1976

sponsor: NAVAL FACILITIES ENGINEERING COMMAND

program nos: WBS 3.1110
3.1110-1B

DDC
RECEIVED
FEB 22 1977
A



CIVIL ENGINEERING LABORATORY

NAVAL CONSTRUCTION BATTALION CENTER
Port Hueneme, California 93043

Approved for public release; distribution unlimited.

Unclassified

SECURITY CLASSIFICATION OF THIS PAGE (When Data Entered)

REPORT DOCUMENTATION PAGE		READ INSTRUCTIONS BEFORE COMPLETING FORM
1. REPORT NUMBER TN-1462 ✓	2. GOVT ACCESSION NO. DN944037	3. RECIPIENT'S CATALOG NUMBER 9 (rept.)
4. TITLE (and Subtitle) A REMOTELY CONTROLLED INCREMENTAL SEAFLOOR CORER .	5. TYPE OF REPORT & PERIOD COVERED Final Jul 1968 - Jun 1976 ✓	
7. AUTHOR(s) M. C. Hironaka	8. CONTRACT OR GRANT NUMBER(s)	
9. PERFORMING ORGANIZATION NAME AND ADDRESS CIVIL ENGINEERING LABORATORY Naval Construction Battalion Center Port Hueneme, California 93043	10. PROGRAM ELEMENT, PROJECT, TASK AREA & WORK UNIT NUMBERS 63713N, S4636X, WBS 3.1110, 3.1110-1B	
11. CONTROLLING OFFICE NAME AND ADDRESS Naval Facilities Engineering Command Alexandria, Virginia 22332	12. REPORT DATE November 1976	13. NUMBER OF PAGES 24
14. MONITORING AGENCY NAME & ADDRESS (if different from Controlling Office) 1227p	15. SECURITY CLASS. (of this report) Unclassified	
16. DISTRIBUTION STATEMENT (of this Report) Approved for public release; distribution unlimited 14 CEL-TN-1462		
17. DISTRIBUTION STATEMENT (of the abstract entered in Block 20, if different from Report)		
18. SUPPLEMENTARY NOTES		
19. KEY WORDS (Continue on reverse side if necessary and identify by block number) Seafloor core sampler, seafloor coring, corer, soil sampling, sediment sampling, equipment, hardware, incremental, bottom resting.		
20. ABSTRACT (Continue on reverse side if necessary and identify by block number) A bottom-resting corer has been designed that can be remotely operated from a control console located aboard a support vessel; the corer can obtain relatively undisturbed samples of the complete sediment profile to 50 feet (15 m) in water depths to 6,000 feet (1,830 m). The corer is 10 feet wide by 13 feet long (24 feet wide by 27 feet long with bearing pads extended) by 17 feet high, and weighs 26,500 pounds when submerged in seawater (30,200 pounds in air). It is operated via a combined load/power/telemetry		

DD FORM 1 JAN 73 1473 EDITION OF 1 NOV 65 IS OBSOLETE

Unclassified

SECURITY CLASSIFICATION OF THIS PAGE (When Data Entered)

391 111

LB

Unclassified

SECURITY CLASSIFICATION OF THIS PAGE(When Data Entered)

20. Continued

(electromechanical) cable to take core samples from the same hole in the sediment profile in ten increments, each sample of which is 3 inches in diameter and 5 feet long. The corer is completely self-contained, including core barrels and drill pipes necessary for sampling to 50 feet. The corer has not been evaluated at sea. Sufficient land tests have been performed to suggest that the mechanical design is functional. Problems still exist in the system, but most of these appear to be correctable and of a nondevelopmental nature.

Library Card

Civil Engineering Laboratory
A REMOTELY CONTROLLED INCREMENTAL SEAFLOOR
CORER (Final), by M. C. Hironaka
TN-1462 24 pp illus November 1976 Unclassified

1. Seafloor coring 2. Seafloor core sampler I. WBS 3.1110, 3.1110-1B

A bottom-resting corer has been designed that can be remotely operated from a control console located aboard a support vessel; the corer can obtain relatively undisturbed samples of the complete sediment profile to 50 feet (15 m) in water depths to 6,000 feet (1,830 m). The corer is 10 feet wide by 13 feet long (24 feet wide by 27 feet long with bearing pads extended) by 17 feet high, and weighs 26,500 pounds when submerged in seawater (30,200 pounds in air). It is operated via a combined load/power/telemetry (electromechanical) cable to take core samples from the same hole in the sediment profile in ten increments, each sample of which is 3 inches in diameter and 5 feet long. The corer is completely self-contained, including core barrels and drill pipes necessary for sampling to 50 feet. The corer has not been evaluated at sea. Sufficient land tests have been performed to suggest that the mechanical design is functional. Problems still exist in the system, but most of these appear to be correctable and of a nondevelopmental nature.

Unclassified

SECURITY CLASSIFICATION OF THIS PAGE(When Data Entered)

CONTENTS

	page
INTRODUCTION	1
Objective	1
Background	1
DESCRIPTION OF CORER SYSTEM	2
OPERATION PROCEDURE	12
FUNCTIONAL TESTS	14
Dry Land Tests	14
Underwater Tests	17
SUMMARY	19
REFERENCES	23

ACCESSION #		
HTS	STATE SYMBOL	<input checked="" type="checkbox"/>
DD	NAVY SYMBOL	<input type="checkbox"/>
UNANNOUNCED		<input type="checkbox"/>
JUSTIFICATION		
BY		
DISTRIBUTION/AVAILABILITY CODES		
Dist.	AVAIL.	and/or SPECIAL
A		

INTRODUCTION

Objective

The objective of this project was to develop a corer that could (a) take relatively undisturbed samples of cohesive seafloor soils from sediment depths to 50 feet (15 m), (b) operate in water depths to 6,000 feet (1,830 m), and (c) be deployed from a relatively small vessel. This report documents the results of this developmental effort.

Background

Seafloor soil samples are required for determining the physical and engineering properties of soils at particular seafloor sites of interest to the Navy. These properties are required for such applications as (a) designing safe and economical seafloor structures, (b) establishing correlation/correction factors for strengths measured in-situ and strengths measured in the laboratory, (c) tracing and extrapolating geological features important to the stability of seafloor installations, (d) analyzing operations (including trafficability) with seafloor excavators and other seafloor mobile equipment, and (e) solving problems related to object penetration and breakout. Thus, in preparation for future seafloor soil data applications as above, the Civil Engineering Laboratory (CEL) was tasked by the Naval Facilities Engineering Command under the Deep Ocean Technology Program to develop a seafloor corer with the performance criteria as specified in the objective above.

Presently, there are no corers capable of taking undisturbed samples from sediment depths of 50 feet (15 m) in water depths to 6,000 feet (1,830 m). Core samples for engineering purposes are currently being taken with various forms of oceanographic samplers, samplers used in the drill string of drilling vessels, and bottom-sitting platforms. Some of the shortcomings of oceanographic samplers are: (1) short cores, (2) location of the retrieved sample in the sediment column not always known, (3) occasionally samples are not vertically orientated, and (4) samples are disturbed (in the engineering sense) due to large area ratios, large length-to-diameter (L/D) ratios, and other factors as described by Hvorslev [1]. Penetration of these samplers into the seafloor is dependent on the energy available, characteristics of the sampler, and characteristics of the sediments; thus, samples from a required sediment depth, such as 50 feet (15 m), are often not obtainable. A piston aids in obtaining longer samples; however, the oscillations created in the cable due to release of stored elastic energy in the cable upon triggering and free falling of the corer often destroy the effectiveness of the piston. Thus, oceanographic samplers usually do not satisfy engineering requirements.

Some of the above shortcomings also apply to samplers used in the drill string of drilling vessels. However, a major disadvantage of this type of sampler is that a relatively expensive drilling vessel is required for sampling operations. There is also the possibility that a drilling vessel will not be available when it is needed. Additionally, because of the weight of the drill string and the weak surface sediments, the drill string quite often may penetrate 10 or more feet (3+m) before it is realized that the drill string has encountered the bottom. Thus, if a core was taken inside the drill string, it would not be known where in the sediment profile the sample was retrieved from. In anticipated future Navy requirements, the properties of these surface sediments will have the most importance, and these sediments are often bypassed with the drill string sampling method.

Some of the shortcomings discussed above also apply to bottom-sitting corers. Additionally, these corers possess some of the following disadvantages: (1) diver-operated and, thus, limited to shallow-water applications; (2) designed to sample hard materials, such as rock and coral, and, thus, do not necessarily obtain samples of the more prevalent weak cohesive soils; and (3) designed to operate in maximum water depths considerably less than 6,000 feet (1,830 m).

To overcome these shortcomings and to meet the objective of obtaining relatively undisturbed samples to sediment depths of 50 feet (15 m) in water depths to 6,000 feet (1,830 m) with a relatively small, readily available and inexpensive vessel, a remote-controlled, bottom-sitting corer was designed and fabricated under contract for the Navy by Ocean Science and Engineering, Long Beach, California. The use of a bottom-sitting platform has several advantages: (a) a relatively small, nonspecialized vessel can be used, thereby minimizing vessel availability problems; (b) the location in the soil profile from which each sample is taken is positively referenced with respect to the seafloor surface; and (c) sampler characteristics can be utilized for minimizing sample disturbance (as suggested by Hvorslev [1]).

Cohesive seafloor soils, particularly those at the surface, are usually weak and, thus, possess the potential for causing the most foundation/soils related problems. Since the deep ocean bottom is generally composed of cohesive fine-grained soils, the development of the corer was directed toward taking high-quality, relatively undisturbed samples of such soils as opposed to sampling coarse-grained soils, such as sand. Ideally, it would have been desirable to incorporate capabilities to sample all types of ocean bottom soils; however, due to funding limitations this was not practical.

DESCRIPTION OF CORER SYSTEM

The complete corer system as designed and fabricated includes an underwater platform (Figure 1), electromechanical handling cable (Figure 2), a deck-mounted lifting winch (Figure 3), a power unit (Figure 4), and a control console (Figure 5).

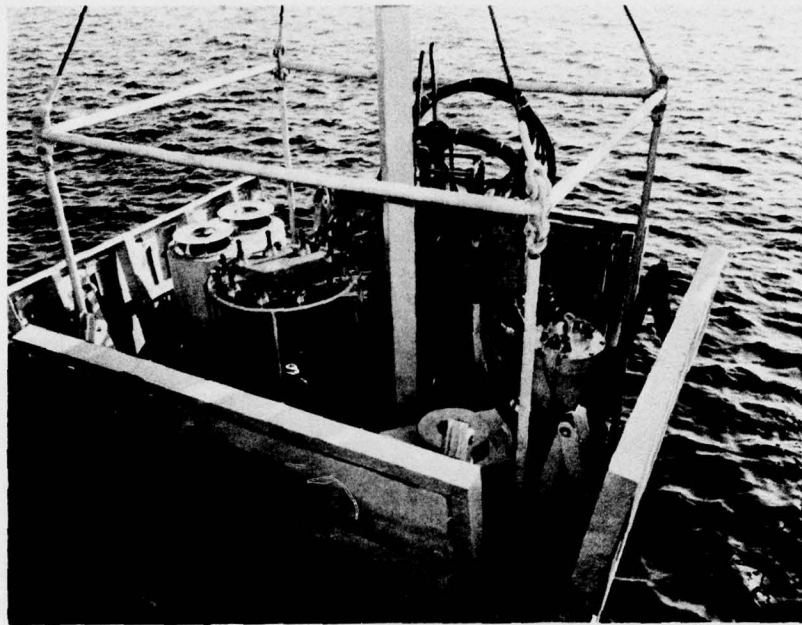

Figure 1. Seafloor corer during underwater functional tests.

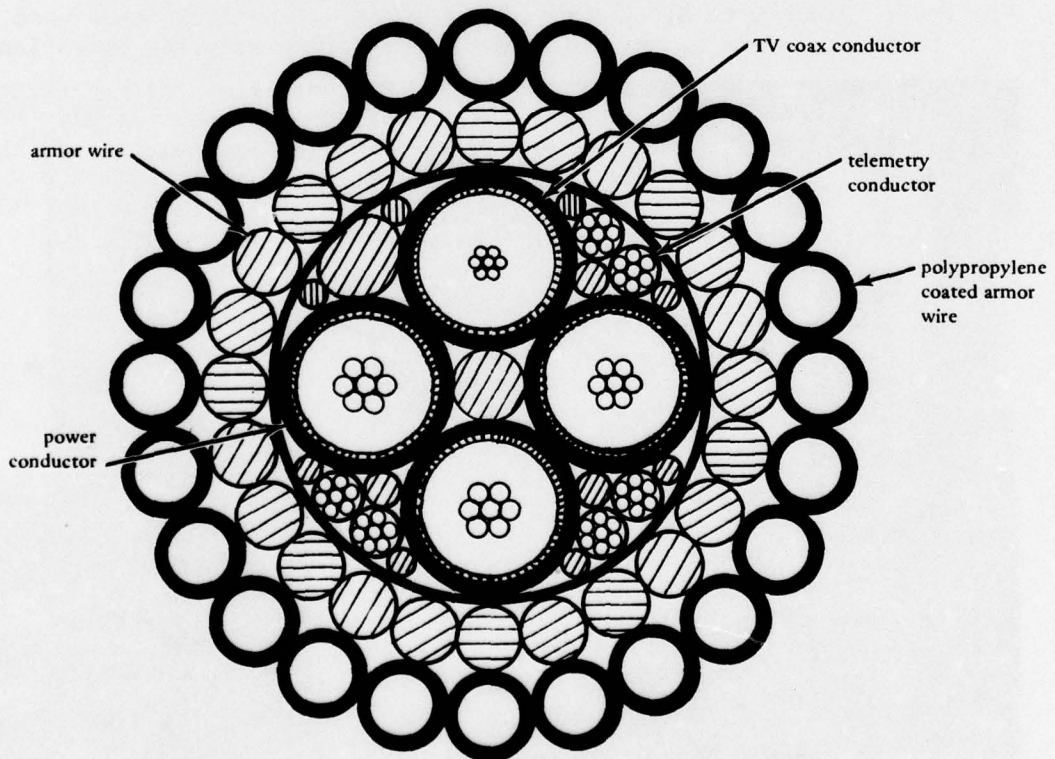

Figure 2. Cross section of the electromechanical lift cable.

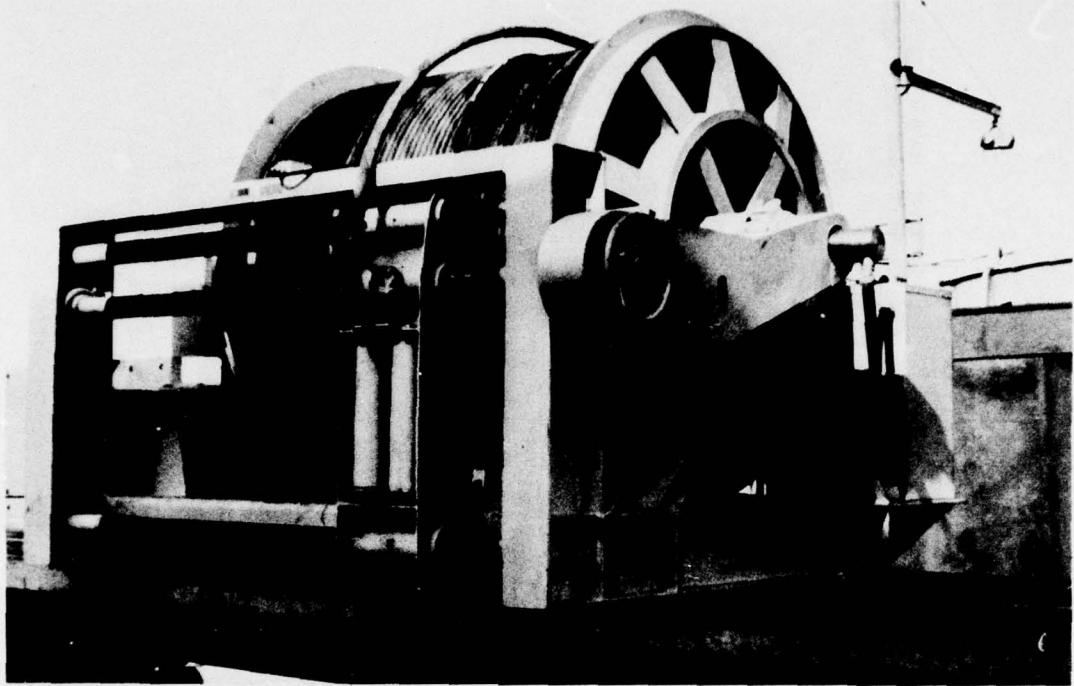

Figure 3. Winch with 8,000 feet of the electromechanical cable used to lower, operate, and raise the corer during sampling operations.

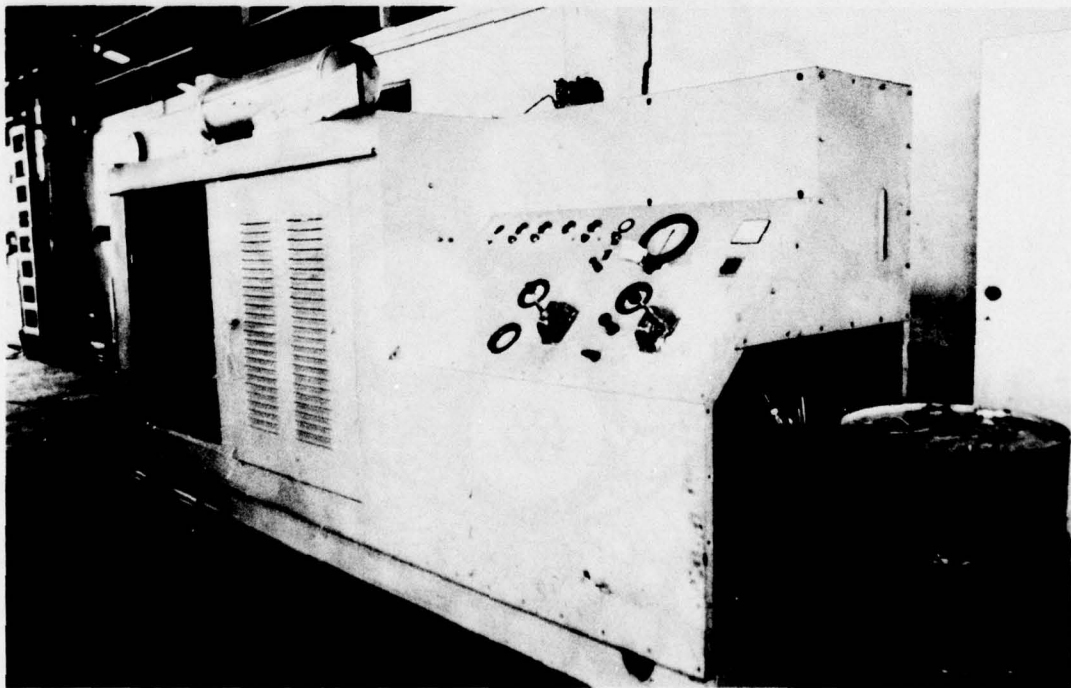

Figure 4. Power unit for providing hydraulic power to operate the lifting winch and for electrical power to operate the corer.

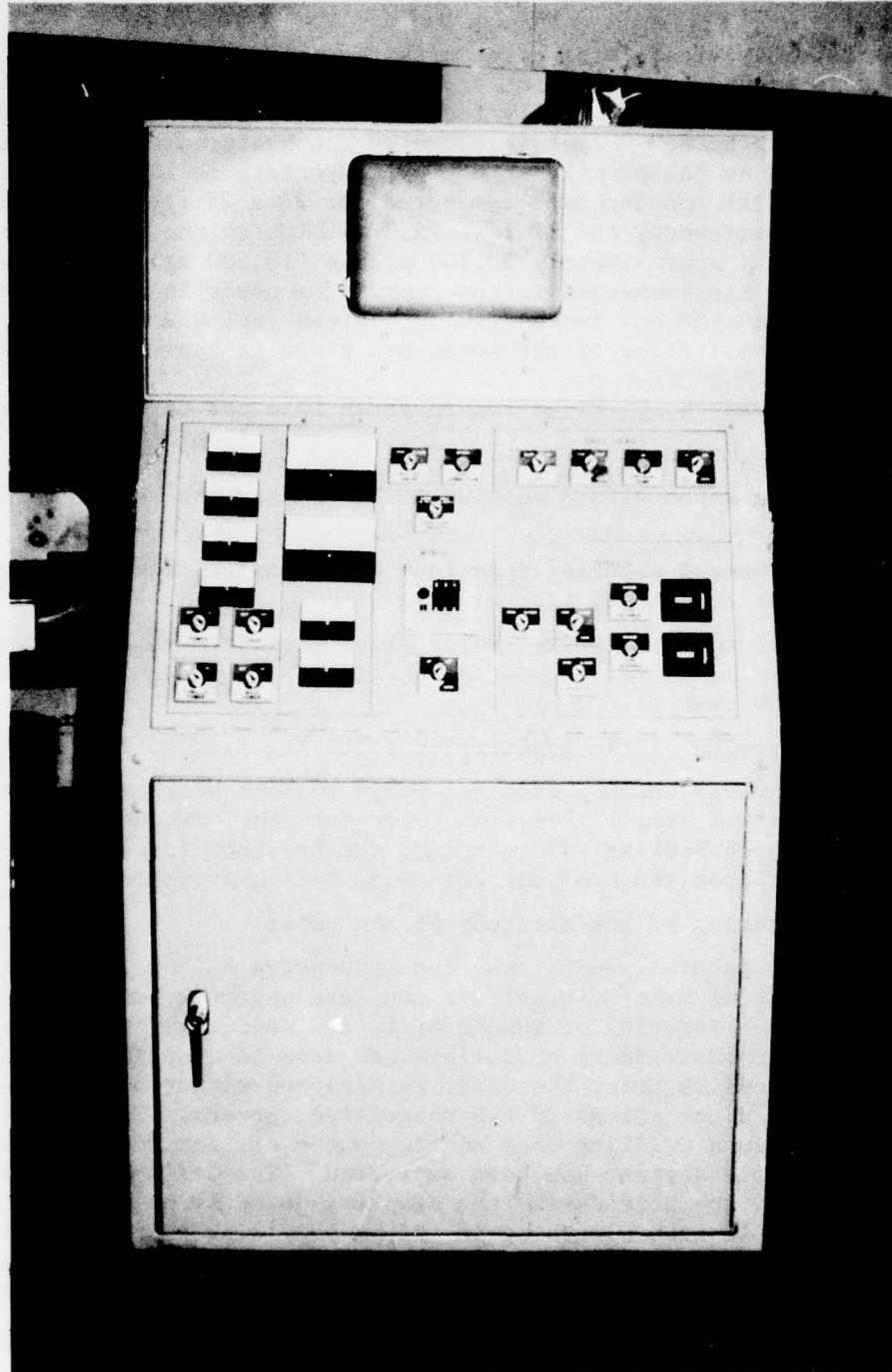

Figure 5. Control console used to remotely operate the corer from the surface support vessel.

An assembly view of the corer with the major components identified is shown in Figure 6. The corer platform contains all of the components for taking core samples remotely from sediment depths to 50 feet (15 m) in water depths to 6,000 feet (1,830 m). The basic corer platform, which utilizes steel as the primary structural material, is 10 x 13 feet (3.0 x 4.0 m) with the bearing pads retracted, or 24 x 27 feet (7.3 x 8.2 m) with the pads extended, and 17 feet (5.2 m) high to the top of the winch post. It weighs approximately 30,200 pounds (13,700 kg) in air and 26,500 pounds (12,000 kg) submerged in seawater. The corer is operated with an electrical system and two hydraulic systems (oil and water). Other physical characteristics of the corer are given in Table 1.

Features and capabilities incorporated into the corer include:

1. Fixed-piston sampling technique
2. Sample taken with a pushing action beyond the end of the drilling shoe
3. Incremental sampling technique - 10 samples, each 3 inches (7.6 cm) in diameter and 5 feet (1.5 m) long
4. Sample cohesive soils having shear strengths ranging from 0.1 to 10 psi (0.69 to 69 kPa) to sediment depths of 50 feet (15 m) in water depths to 6,000 feet (1,830 m)
5. Monitoring of the penetration force required to take each sample
6. Extendable bearing pads for large support bearing area on soft seafloor soils and hinged plates or louvres on the bottom surface of the main platform and each bearing pad to reduce the breakout force required to lift the corer from the seafloor after completion of operations
7. Monitoring of the attitude of the corer

The corer is designed to take ten successive 5-foot (1.5-m) long samples from the same hole to provide a complete sediment profile to 50 feet (15 m) with each lowering of the corer to the seafloor. Alternate coring and reaming (in that order) operations are used in sampling the soil profile. To accomplish this, the corer is equipped with ten core barrels and nine drill pipes placed in the respective turrets. The first drill pipe section has a drilling shoe on the bottom end for reaming the hole after each sample segment has been extracted. The drill string also acts as a casing for the hole during the sampling phase by preventing the sides of the hole from sloughing in and by providing a pressure-tight chamber during the driving of each core. Each core barrel is driven into the soil by high-pressure seawater, which is forced down the drill string, impinging on a piston.

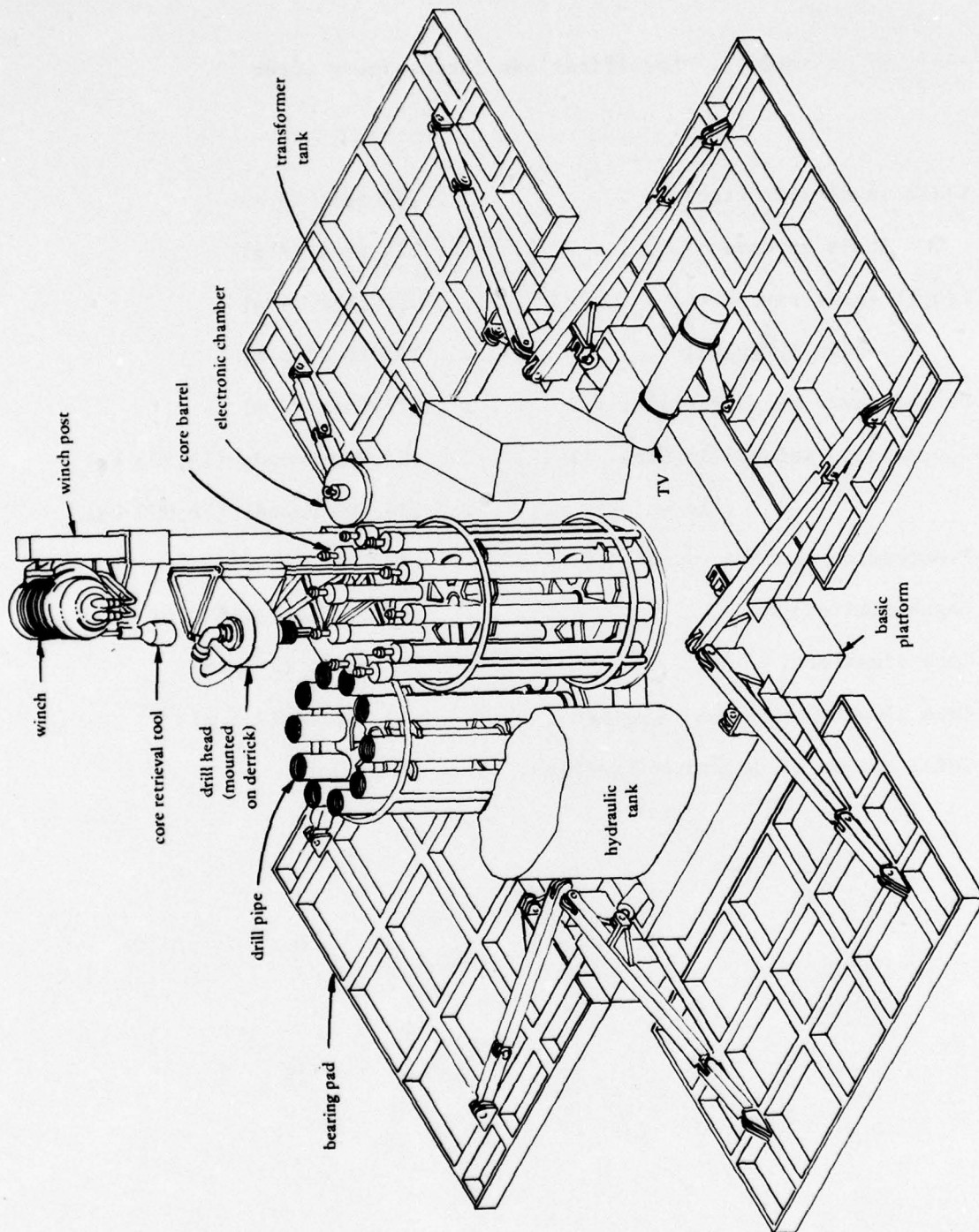

Figure 6. Major components of the seafloor corer.

Table 1. Specifications for Seafloor Corer

Width (pads retracted)10 feet (3 m)
(pads extended)24 feet (7 m)
Length (pads retracted)13 feet (4 m)
(pads extended)27 feet (8 m)
Height (over winch post)17 feet (5 m)
Approximate weight (in air)30,200 pounds (13,700 kg)
(in water)26,500 pounds (12,000 kg)
Penetration profile capability.50 feet (15 m)
Depth limitation.6,000 feet (1,830 m)
Core diameter3 inches (7.6 cm)
Core length (individual sample).60 inches (1.5 m)
Total number of sequential samples.10

The electrical control system is used to power and remotely control the corer from the surface through the electromechanical lift cable. The 75-kW, 440-volts AC, 60-Hertz, 3-phase electrical power is provided by the diesel power unit to a transformer located on the main winch. This step-up transformer converts the power to 2,300 volts AC, in which form it is transmitted through the electromechanical cable to the corer. Transformers on the corer convert this power back down to 440 volts AC to power the motors (10, 15, and 30 hp; 7.5, 11.2, and 22.4 kW) for the pumps (centrifugal water, high-pressure water, and hydraulic system) and to 115 volts AC to power the control circuits, television camera, and lights.

Both pressure-compensated and pressure vessel containers are used to house the components of the electrical control system. The transformers are contained in a pressure-compensated housing filled with transformer oil. All of the electrical controls, motor starters, and telemetering systems are contained in a one-atmosphere pressure vessel. The interconnecting electrical wiring for the transformer housing, atmospheric chamber, hydraulic reservoir, and limit switches is contained in clear flexible plastic tubes that are filled with transformer oil to produce a pressure-compensated system. The electrical connectors are also oil-filled through a bleed hole in each connector which transmits the transformer oil from the plastic conduit to the interface between the connector halves.

The corer functions are controlled by a frequency-shifted FM multiplex system. Twenty FM channels with frequencies ranging from 425 Hertz to 3,655 Hertz are used to transmit and receive signals from the corer. The transmitters and receivers are located in the control console on deck and in the atmospheric chamber on the corer. Each transmitter and receiver combination is tuned to a particular discrete frequency range. Each channel is separated by 170 Hertz to minimize cross-talk. A switch closure at the control console or the corer unit causes the appropriate transmitter to shift its output frequency. This shift in frequency is sensed by the matching receiver, which turns on a relay that causes the desired function to occur. All signal frequencies originating at the control console are transmitted to the corer through a twisted pair of signal wires in the electromechanical lift cable. A second twisted pair of signal wires is utilized for feedback signals originating from the corer unit.

The hydraulic system provides power, which is obtained from a hydraulic pump driven by the 30 hp (22.4 kW) electric motor, to perform all functional operations of the corer. The pump, motor, and all solenoid valves of the system are contained in a pressure-compensated reservoir filled with hydraulic oil (MIL-H-5606). Flexible hoses from the reservoir connect all external cylinders and motors to the control valves. These cylinders and motors perform the following operations on the corer:

1. Extend and retract the bearing pads
2. Raise, lower, and rotate the drill head
3. Index each turret and position the pipe or core barrel turret over the hole

4. Open and close gates on the pipe and core barrel turret
5. Open and close the support plate under each core barrel to drop a fresh core barrel into the hole
6. Operate the pipe breakout mechanism to break pipe connections and hold the pipe string in the hole
7. Tilt and erect the derrick and TV camera
8. Close the water bypass valve for taking a core or flushing out cuttings from the hole during reaming
9. Operate the core retrieval winch

The water system is used to drive the core barrel during sampling and flush the hole of drill cuttings during reaming operations. Water for these operations is provided from two pumps through a water swivel on the drill head. The first unit is a centrifugal pump which is used to supply low-pressure water at approximately 150 gpm (570 l/min) to the drill string for flushing out drill cuttings from the hole. The seawater that is pumped down the inside of the drill pipe during the reaming operation circulates back up and around the outside of the drill pipe to remove the drill cuttings from the hole. The second pump is a slow-speed, piston, pressure-compensated gear case type that supplies a metered flow of high-pressure (1,000 psi; 6,900 kPa) water for driving the core barrel during sampling. The outlets of these pumps are connected together, but a check valve automatically closes off the centrifugal pump line during the driving of each core. The centrifugal and piston pumps are driven by the 3,600-rpm, 15-hp (11.2-kW) and 1,200-rpm, 10-hp (7.5-kW) pressure-compensated seawater submersible electric motors.

Each core barrel is an assembly consisting of a fixed piston, a mechanism by which the sample tube is pushed to take each sample, and an attachment point for the core retrieval tool. A typical core barrel with these and other features identified is shown in Figure 7. Each core barrel assembly has the following characteristics:

Sample diameter3 inches (7.6 cm)
Sample length-to-diameter ratio20
Area ratio	18%
Inside clearance ratio	0.3%
Outside clearance ratio0.1%
Cutting edge taper	4 degrees
Penetration velocity	variable
Withdrawal velocity3/4 in/sec (1.9 cm/sec) for first 30 seconds; 4 in/sec (10 cm/sec) thereafter

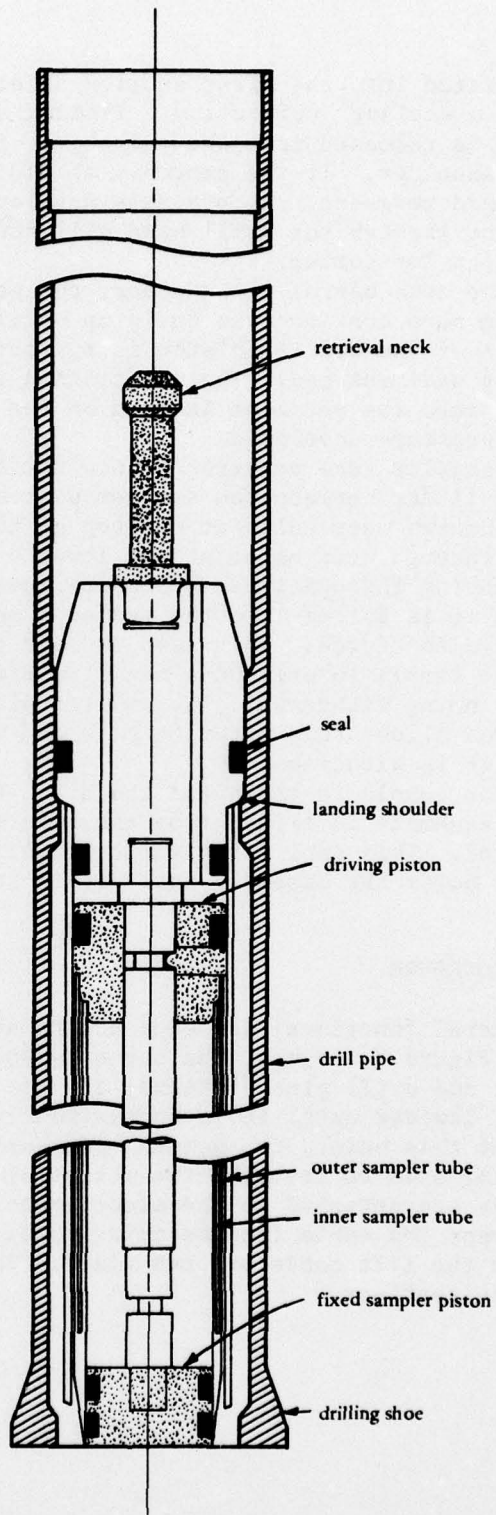

Figure 7. Typical core barrel assembly.

Incorporated into the first section of drill pipe is a replaceable bushing with a sealing surface and a landing shoulder. When the core barrel assembly is released from the turret, it falls into the pipe and stops against the shoulder. If the assembly should encounter any resistance to its downward movement, the pressure developed when water is pumped down the drill pipe through the drill head will force the assembly into the proper position for coring.

After the core barrel is in place, the seawater pressure generated by the piston pump continues to build up until the pressure being applied over the area of the driving piston is sufficient to force the sampler tube into the sediment bed. The penetration force required to push the sampler tube into the sediment is read on the control console as a function of the pressure developed.

As the sampler tube penetrates into the sediment bed, the fluid trapped in the cylinder between the sampler piston and the driving piston is forced out through weep holes at the top of the inner sampler tube, and finally out through weep holes at the lower end of the outer sampler tube. The fluid passing through these holes lubricates the outside of the sampler tube as it is forced into the sediment bed, thereby reducing the required penetration force. This same passage permits water to flow to the bottom of the sample to prevent a negative differential pressure from forming as it is being withdrawn. The smaller diameter at the lower end of the piston rod allows this water to pass and fill the void that is formed as the sampler is withdrawn.

After the sample is taken and the drill head is disconnected, the core barrel assembly is lifted from the hole by means of the winch-powered retrieval tool. This tool fits over the retrieval neck of the assembly and securely holds the assembly until it is stored.

OPERATION PROCEDURE

The general functional sequence during actual operation of the corer is shown in Figure 8. First, the corer is equipped with the necessary core barrels and drill pipe sections, and the system is checked out. Then the corer is lowered until it is approximately 100 feet (30 m) above the seafloor. At this point, the bearing pads are extended to provide additional bearing area to transmit the weight of the corer to the soil. Sub-surface buoys are attached to the electromechanical lift cable at this time to prevent the cable from becoming fouled with the corer mechanisms in the event the lift cable becomes slack. The corer is now ready to be placed on the seafloor.

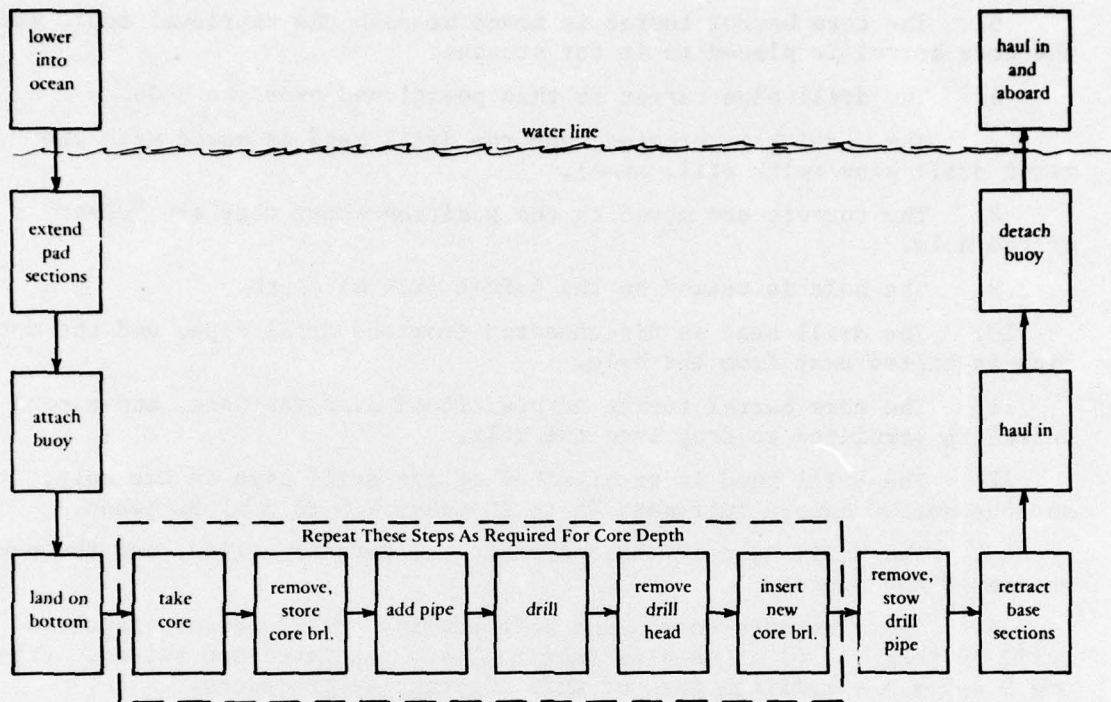

Figure 8. Function sequence diagram for seafloor corer.

Once the corer is on the seafloor, the sampling operations are performed as follows:

1. The first core barrel assembly, which was attached to the drill head onboard the surface vessel, takes the first sample increment from 0 to 5 feet (0 to 1.5 m). The first core barrel is different from the remaining nine as it has an outer sleeve to facilitate its coupling with the drill head.
2. The drill head is uncoupled from the first core barrel assembly.
3. The derrick is tilted to move the drill head out of alignment with the hole.
4. The core barrel retrieval tool picks up the first core barrel assembly.

5. The core barrel turret is moved beneath the retrieval tool, and the core barrel is placed in it for storage.

6. The drill pipe turret is then positioned over the hole.

7. The derrick is erected, and the drill head is mated with the first drill pipe (with drill shoe).

8. The turrets are moved to the position where they are "clear" of the hole.

9. The hole is reamed to the 5-foot (1.5 m) depth.

10. The drill head is disconnected from the drill pipe, and the derrick is tilted away from the hole.

11. The core barrel turret is positioned over the hole, and a core barrel is permitted to drop into the hole.

12. The drill head is re-attached to the drill pipe in the hole, and the second sample increment (5 to 10 feet; 1.5 to 3 m) is taken.

13. The drill head is disconnected, the derrick tilted, and the core retrieved and stored.

14. The alternate coring and hole reaming procedures are repeated until 50 feet (15 m) of samples (maximum) are retrieved and stored. Figure 9 shows a simplified form of this alternating procedure.

15. The corer is then brought to the surface with the pads retracted and the buoys removed from the cable. The samples are removed and new core barrels are installed on the corer for sampling at another location.

Further details on the corer system and its operation can be found in the operation and maintenance manual and vendor data for the system (References 2 and 3).

FUNCTIONAL TESTS

Both dry land and underwater tests were performed on the corer to verify functional operation and watertightness of the system. Simulated and actual coring operations in a test pit were performed.

Dry Land Tests

These tests were conducted in a pit 30 inches (76 cm) in diameter and approximately 60 feet (18 m) deep located at the contractor's (Ocean Science and Engineering, Inc.,) plant in Long Beach, California. The pit was backfilled with clay soil and compacted. Water was placed over the soil in the pit and permitted to stand for several weeks to allow permeation and simulation of underwater conditions. This cover of water was also maintained during coring tests. The corer was positioned and leveled over the test pit during this period. All components of the corer system were connected and checked in preparation for the tests.

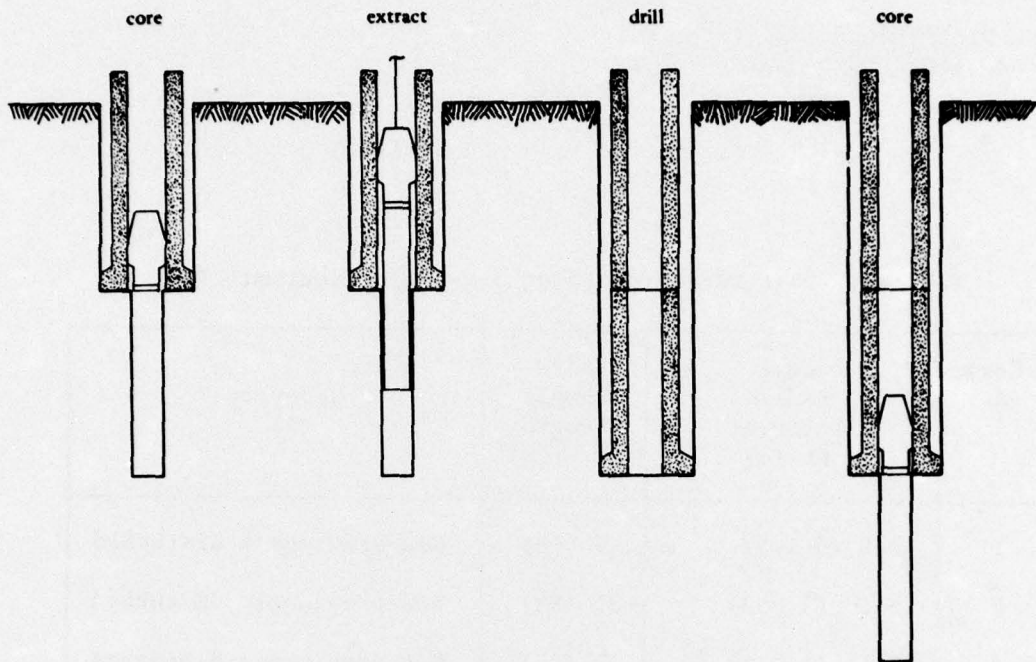

Figure 9. Simplified sampling and drilling procedure.

All tests were performed according to an established test procedure given in Appendix I of Reference 4. The water, hydraulic, and electrical control systems and mechanical components were tested. Adjustments and corrections were made as necessary to properly operate the corer during the coring tests.

Ten cores were attempted in the test pit. The major difficulty encountered in securing the ten cores involved returning the extended core barrels (containing the samples) to the core barrel turret; seven out of ten core barrels were not properly returned. Two factors caused the problem: (1) the extension of the sample beyond the end of the core barrel (three out of ten cores) eliminated the required clearance between the bottom end of the core barrel and the turret socket (2) the relative tolerance between the upper and lower portions of the core barrel assembly resulted in a less than rigid joint, thereby, causing the bottom of the core barrel to land on the upper edge of the socket rather than in it (four out of ten cores). After the test to 50 feet (15 m) was completed, the core barrels were disassembled, and the core sample lengths measured. The results of those measurements are shown in Table 2.

Table 2. Test Data From First Dry-Land Functional Tests

Core No.	Core Sample Interval ft (m)	Core Sample Length in. (cm)	Recovery (%)
1	0-5 (0-1.5)	7 (18)	N/A-previously disturbed
2	5-10 (1.5-3)	35 (89)	N/A-previously disturbed
3	10-15 (3-4.6)	12 (30)	N/A-previously disturbed
4	15-20 (4.6-6.1)	44 (112)	73
5	20-25 (6.1-7.6)	29 (74)	48
6	25-30 (7.6-9.1)	28 (71)	47
7	30-35 (9.1-10.7)	28 (71)	47
8	35-40 (10.7-12.2)	42 (107)	70
9	40-45 (12.2-13.7)	27 (69)	45
10	45-50 (13.7-15.2)	36 (91)	60

The problem of placing the core barrel assembly into the turret was corrected by installing a hydraulically operated, spring-loaded crank arm to provide a mechanical thrust against the lower end of the core barrel to insure alignment with the socket. This crank arm operated in conjunction with the core turret gate that is located at the top of the turret assembly; together they provide mechanical thrust to the upper and lower portions of the core barrel to insure proper storage.

After the above core barrel/turret return problem was corrected and the test pit was backfilled with new soil, the functional tests were repeated. The corer system functioned through all the cores. Some problems were encountered with the pick-up of core number 1 (which is slightly different from the others) with the retrieval tool and make-up of the drill head with pipe number 1 in the turret and number 2 in the hole. All ten core barrels extended properly and were stored in the core barrel turret without incident. The lengths of the core samples obtained in this functional test along with nominal penetration force and vane shear strength for some of the samples are shown in Table 3.

To solve the problems encountered in the second functional tests, the retrieval neck on core barrel assembly number 1 and drill pipe number 2 were replaced, and drill pipe number 1 was realigned in the turret. Repeated tests were made of these components to insure readiness of the system for underwater tests.

Underwater Tests

Underwater tests were performed at the contractor's facility in Long Beach and in Port Hueneme Harbor. The procedures outlined in the operation and maintenance instruction (Reference 2) were used in performing the tests.

The first underwater test of the corer was conducted in 40 feet (12 m) of water in the harbor in Long Beach. With the corer on the bottom, the system was activated and operated. The core barrels were not inserted in the drill pipes and extended because of the possibility of damaging them with metal debris in the harbor floor. Drilling operations, however, were performed through the reaming with pipe number 2 without difficulty. Problems were encountered with the limit switch that controls the stopping position of the drill head. This nullified the capability of the unit to break the pipe connection and retrieve and store the pipe sections because the pipe joint was improperly positioned in the breakout clamp system. The cause of the switch malfunctioning was pinpointed to be an improperly shaped gasket that interfered with the switching mechanism. The gasket was changed, and dry-land proofchecks were made.

Table 3. Test Data From Second Dry-Land Functional Tests

Core No.	Core Sample Interval ft (m)	Core Sample Length in. (cm)	Penetration Force lb (N)	Vane Shear Strength* psi (kPa) Taken at			
				4 in. (10cm)	8 in. (20cm)	12 in. (30cm)	16 in. (41cm)
1	0-5 (0-1.5)	0 (0)	1,000 (4,400)				
2	5-10 (1.5-3)	12 (30)	Not observed				
3	10-15 (3-4.6)	41 (104)	500 (2,200)				
4	15-20 (4.6-6.1)	31 (79)	1,200 (5,300)	0	0.4 (2.8)	0.4 (2.8)	0.8 (5.5)
5	20-25 (6.1-7.6)	0 (0)	1,000 (4,400)				
6	25-30 (7.6-9.1)	0 (0)	500 (2,200)				
7	30-35 (9.1-10.7)	55 (140)	1,200 (5,300)				
8	35-40 (10.7-12.2)	60 (152)	1,200 (5,300)	0	0	0.2 (1.4)	0.2 (1.4)
9	40-45 (12.2-13.7)	36 (91)	1,100 (4,900)				
10	45-50 (13.7-15.2)	50 (127)	1,000 (4,400)	0.8 (5.5)	0.4 (2.8)	0.4 (2.8)	0.6 (4.1)

* Vane shear measurements were made with a hand-held device at 4, 8, 12, and 16 inches (10, 20, 30, and 41 cm) from the bottom of core numbers 4, 8, and 10 only.

Two attempts were made to perform underwater functional tests of the corer in Port Hueneme Harbor as part of contract acceptance test requirements. In the first attempt, the system was located on board the CEL Warring Tug. The corer itself was submerged over the bow of the Warring Tug. The system performed smoothly through the pre-launch system checkout and coring operations through the taking of core number 1. At this point, the drill head did not uncouple from the core barrel assembly. The cause of the problem was later isolated to be in the electronic control circuitry in which relay failures occurred rather frequently. To minimize these failures, varistors across each relay contact were introduced into the circuitry.

After the above circuitry modifications were completed, a second attempt was made to perform the underwater functional tests. The system for this test was located on one of the docks at the Harbor. The corer was suspended in the water from a dockside crane. The system operated smoothly through the uncoupling of the drill head from core barrel assembly number 1. Problems were experienced at this point with the attachment of the retrieval tool onto core barrel number 1. It was later determined that the alignment of the winch post was incorrect for proper retrieval of the core barrel. The winch post was realigned, and the retrieval of the core barrel verified.

Further underwater tests were not attempted, and developmental work on the corer was concluded at this stage.

SUMMARY

Although underwater coring tests were not performed, the tests performed on land suggest that the mechanical design of the seafloor corer is functional. The development of the corer resulted in several technological advances. Some problems still exist with the system, but these problems appear to be correctable and of a nondevelopmental nature.

As demonstrated in the dry land tests, the corer has taken samples to soil depths of 50 feet (15 m). Although the core recovery rate was less than 100% (60-inch (1.5 m) long sample), it is considered that the coring technology is not deficient in this regard. The poor recovery percentages can be explained as follows: (a) the soil profile in the pit was highly disturbed during trial tests, resulting in very weak fluid-like soil layers in the column; (b) gravel (up to 33% by weight) was present in the soil profile; (c) some of the core material tended to fall out because of low friction (due to very weak sample) between the core barrel wall and the sample, and higher force (weight) in the out-of-the-water condition tending to draw the sample out of the core barrel. Sample recovery should approach 100% in undisturbed soil while coring under submerged conditions.

The major technological advances made in the development of the corer include:

1. A remotely controlled bottom-sitting incremental coring system for water depths to 6,000 feet (1,830 m). Previous systems were operated by divers or were designed to be used in shallow water.
2. A unique core barrel assembly that utilizes a truly fixed piston and optimum features that minimize sample disturbance. This core barrel assembly does not have a precedent.
3. A mechanically operated core barrel assembly retrieval tool for retrieving each assembly from the hole and returning and releasing it in the turret. This device also has no precedent.
4. A turret system that positions either a core barrel or drill pipe (or neither in the clear position) over the drill hole, plus individual turret indexing.
5. A louvre system that provides a large bearing area for supporting the corer weight on soft seafloor soils. It also minimizes breakout forces by hinging during uplift from the seafloor.

Some physical, mechanical, operational, and electrical control system problems still exist in the corer as follows:

1. The weight of 26,500 pounds (12,000 kg) submerged [30,200 pounds (13,700 kg) in air] is high. For operations in 6,000-foot (1,830-m) water depths, the safety factor of the lifting cable is only 3.5. Such a safety factor is low for at-sea operations. This problem is probably best resolved by using lighter weight structural material such as aluminum.
2. The tolerance for the alignment of the drill head with the drill pipes in the turret is small, and, therefore, alignment must be accurate in order for these parts to mate. The accumulation of tolerances in the turret system sometimes causes these parts to become misaligned. This problem may be solved by using a more tapered thread system for mating these components, by making the turret system more rigid or by substituting the turret system with a new storage system.
3. It is difficult to determine when the core barrel has fully penetrated with the present method of monitoring the penetration force. A more refined feedback system should be used.
4. It is not known when the threads on the drill head and drill pipe are completely connected or uncoupled and ready for separation. Presently, these operations are timed (10 seconds). A positive method to determine that the threads have become disengaged can be achieved by sensing with an accelerometer the sudden drop of the drill head as it passes over the beginning of each thread. Sensing the drill head rotation could reveal when the pipes are completely coupled.

5. It is not known whether the extended core barrel that contains a sample has been returned to the turret for storage. A positive feedback system, such as from a pressure switch to signal that the core barrel has been returned to the turret, is required. A load cell coupled with the core retrieval tool may also satisfactorily do the job.

6. The circuitry/components associated with the drill head rotation often malfunction. A redesign of that circuit may be required.

7. Voltages as high as 130 volts are being experienced by the components on the corer that were designed to operate at a nominal 115 volts. Item 6 above may be related to this excessive voltage. The simplest solution to this problem is to insert a voltage regulator in the power supply for these components.

8. The television picture is poor when the system is above water and indiscernible when underwater. This problem may be inherent to this particular model camera.

If further developmental work is to be performed on the corer, two major system areas are suggested for improvement - the telemetry system and the electromechanical cable. Presently, the corer functions are controlled by a frequency-shifted FM multiplex system. Approximately 750 distinct steps have to be performed in sequence by the operator to prepare the corer for landing on the seafloor, take 50 feet (15 m) of core samples, retrieve all of the drill pipes, and prepare the unit for recovery. Although a large number of operational steps are involved, the sequence is simple, straightforward, and repetitive (more than 80%). However, if an accurate log is not kept, it is possible to perform operations out of sequence (although interlocks are built into the system to prevent damage). It is, therefore, desirable to automate as much of the operational steps as possible.

The replacement of the FM multiplex system with recently developed microprocessors appears to be an excellent means for automating the operational sequence of the corer. Microprocessors would increase reliability and flexibility, and at the same time, reduce space requirements (smaller one atmosphere pressure chamber on the corer), weight, and costs.

On the present electromechanical lift cable, the outer armor wires are individually coated with a layer of polypropylene to fill up the space between the armor wires.* This polypropylene is relatively easy to abrade, and, thus, the cable requires very careful handling. In at-sea conditions, this careful handling may not always be possible. A new design is, therefore, suggested that would eliminate the polypropylene but maintain or improve the approximately torque-balanced feature of the present cable as shown in Figure 10.

*This space is inherent to this particular designed torque-balanced cable.

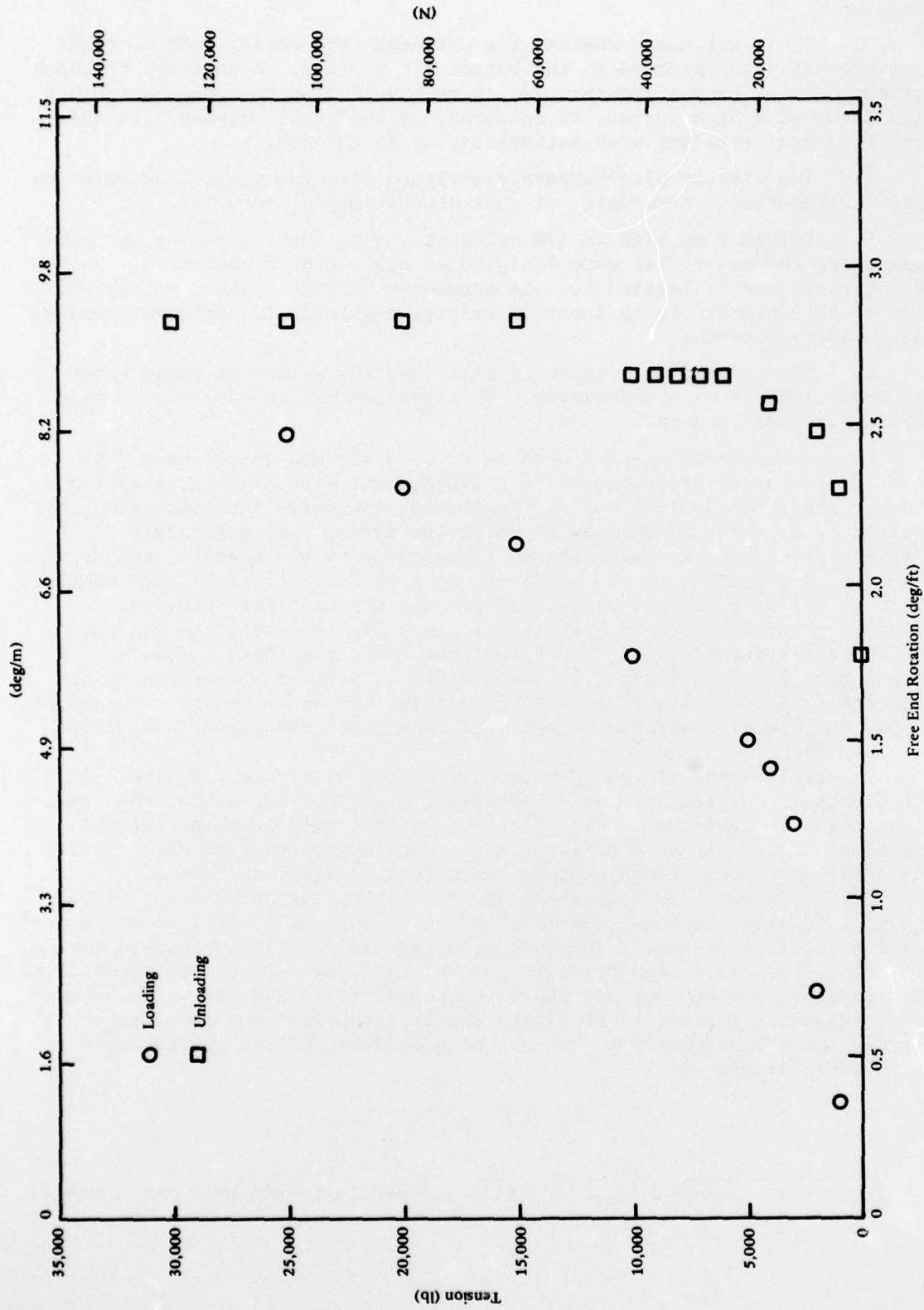

Figure 10. Rotation behavior of the sea floor corer electromechanical cable under tensile loading (After Reference 5).

REFERENCES

1. U. S. Army Engineer Waterways Experiment Station. "Subsurface exploration and sampling of soils for civil engineering purposes," by M. J. Hvorslev, Vicksburg, MS, Nov 1949.
2. Ocean Science and Engineering, Inc. Technical Manual, Volume I: Operation and maintenance instructions, Seafloor corer system. Long Beach, CA, 10 Jun 1974. (Contract N62399-71-C-0021).
3. ————. Technical Manual, Volume II: Vendor data, Sea floor corer system. Long Beach, CA, 10 Jun 1974. (Contract N62399-71-C-0021).
4. ————. Test Report 12-2007C-690-281: Fifty foot deep sea corer, by R. Berkhan. Long Beach, CA, 1 Sep 1972. (Contract N62399-71-C-0021).
5. Naval Research Laboratory. NRL Memorandum Report 2943: Tensile and torsional characteristics of electromechanical cables, by R. K. Samras, Washington, D. C., Nov 1974.

DISTRIBUTION LIST

SNDL Code	No. of Activities	Total Copies	
-	1	12	Defense Documentation Center
FKAIC	1	10	Naval Facilities Engineering Command
FKNI	6	6	NAVFAC Engineering Field Divisions
NKN5	9	9	Public Works Centers
FA25	1	1	Public Works Center
-	6	6	RDT&E Liaison Officers at NAVFAC Engineering Field Divisions
-	218	220	CEL Special Distribution List No. 11 for persons and activities interested in reports on Ocean Engineering