

AD-A035 804

NAVAL POSTGRADUATE SCHOOL MONTEREY CALIF
AN EXAMPLE OF PHASED MISSION RELIABILITY ANALYSIS FOR A HYPOTHE--ETC(U)
DEC 76 S E PILNICK

F/G 15/7

UNCLASSIFIED

NL

1 of 1
ADA035804



END

DATE

FILMED

3 - 77

ADA035804

2

J

NAVAL POSTGRADUATE SCHOOL Monterey, California



THESIS

AN EXAMPLE OF PHASED MISSION
RELIABILITY ANALYSIS FOR A HYPOTHETICAL
NAVAL WEAPONS SYSTEM

by

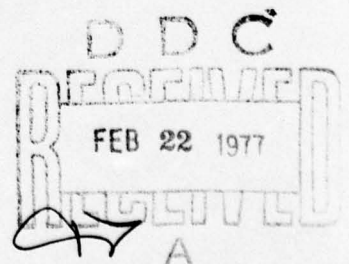
Steven E. Pilnick

December 1976

Thesis Advisor:

J. D. Esary

Approved for public release; distribution unlimited.



UNCLASSIFIED

SECURITY CLASSIFICATION OF THIS PAGE (When Data Entered)

REPORT DOCUMENTATION PAGE		READ INSTRUCTIONS BEFORE COMPLETING FORM														
1. REPORT NUMBER	2. GOVT ACCESSION NO.	3. RECIPIENT'S CATALOG NUMBER														
4. TITLE (and Subtitle) An Example of Phased Mission Reliability Analysis for a Hypothetical Naval Weapons System.		5. TYPE OF REPORT & PERIOD COVERED Master's Thesis, December 1976														
7. AUTHOR(s) Steven E. Pilnick		6. PERFORMING ORG. REPORT NUMBER														
5. PERFORMING ORGANIZATION NAME AND ADDRESS Naval Postgraduate School Monterey, CA 93940		8. CONTRACT OR GRANT NUMBER(s)														
11. CONTROLLING OFFICE NAME AND ADDRESS Naval Postgraduate School Monterey, CA 93940		10. PROGRAM ELEMENT, PROJECT, TASK AREA & WORK UNIT NUMBERS														
14. MONITORING AGENCY NAME & ADDRESS (if different from Controlling Office) Naval Postgraduate School Monterey, CA 93940		12. REPORT DATE DECEMBER 1976														
		13. NUMBER OF PAGES 43														
		16. SECURITY CLASS. (of this report) UNCLASSIFIED														
		15. DECLASSIFICATION/DOWNGRADING SCHEDULE														
16. DISTRIBUTION STATEMENT (of this Report) Approved for public release; distribution unlimited																
17. DISTRIBUTION STATEMENT (of the abstract entered in Block 20, if different from Report)																
18. SUPPLEMENTARY NOTES		<table border="1"> <tr><td colspan="2">ACCESSION for</td></tr> <tr><td>NTIS</td><td>White Section <input checked="" type="checkbox"/></td></tr> <tr><td>DDC</td><td>Buff Section <input type="checkbox"/></td></tr> <tr><td>UNANNOUNCED</td><td><input type="checkbox"/></td></tr> <tr><td colspan="2">JUSTIFICATION</td></tr> <tr><td colspan="2">BY</td></tr> <tr><td colspan="2">DISTRIBUTION STATEMENT CODES</td></tr> </table>	ACCESSION for		NTIS	White Section <input checked="" type="checkbox"/>	DDC	Buff Section <input type="checkbox"/>	UNANNOUNCED	<input type="checkbox"/>	JUSTIFICATION		BY		DISTRIBUTION STATEMENT CODES	
ACCESSION for																
NTIS	White Section <input checked="" type="checkbox"/>															
DDC	Buff Section <input type="checkbox"/>															
UNANNOUNCED	<input type="checkbox"/>															
JUSTIFICATION																
BY																
DISTRIBUTION STATEMENT CODES																
19. KEY WORDS (Continue on reverse side if necessary and identify by block number) Reliability analysis; phased mission		A														
20. ABSTRACT (Continue on reverse side if necessary and identify by block number) In a phased mission, the functional organization of the system changes during consecutive time periods, which introduces analysis complexities not present with just a single phase. This occurs since the performance of a particular component in one phase of the mission is not independent of its performance in another phase. In this paper, an example is analyzed, largely with graphical techniques and diagrams, so as to avoid the complicated mathematics which characterize much of the existing methodology.																

251450

LB

AN EXAMPLE OF PHASED MISSION RELIABILITY ANALYSIS FOR A
HYPOTHETICAL NAVAL WEAPONS SYSTEM

by

Steven E. Pilnick
Lieutenant, United States Navy
B.E., State University of New York at Stony Brook, 1970

Submitted in partial fulfillment of the
requirements for the degree of

MASTER OF SCIENCE IN OPERATIONS RESEARCH

from the
NAVAL POSTGRADUATE SCHOOL
December 1976

Author:

Steven E. Pilnick

Approved by:

James D. Esary

Thesis Advisor

Melvin B. Kline

Second Reader

Michael J. Averey

Chairman, Department of Operations Research

David A. Murray

Dean of Information and Public Sciences

ABSTRACT

In a phased mission, the functional organization of the system changes during consecutive time periods, which introduces analysis complexities not present with just a single phase. This occurs since the performance of a particular component in one phase of the mission is not independent of its performance in another phase. In this paper, an example is analyzed, largely with graphical techniques and diagrams, so as to avoid the complicated mathematics which characterize much of the existing methodology.

TABLE OF CONTENTS

I.	INTRODUCTION.....	7
II.	THE SLBM SYSTEM.....	8
III.	PROBLEM ANALYSIS.....	11
	A. PHASE SEQUENCE DIAGRAM.....	11
	B. PHASE BLOCK DIAGRAMS.....	11
	1. Cut Cancellation.....	14
	2. Transformation.....	17
	C. RELIABILITY OF PSEUDO-COMPONENTS.....	22
	1. Conditional Component Phase Reliability..	24
	2. Unconditional Component Reliability.....	24
	D. OBJECTIVE RELIABILITY.....	25
	1. Objective Block Diagrams.....	27
	2. Objective Reliability Evaluation.....	27
	E. MISSION SUCCESS.....	30
	1. Successful Mission Outcomes.....	36
	2. Mission Success Levels.....	36
	3. Expected Success.....	39
	LIST OF REFERENCES.....	41
	INITIAL DISTRIBUTION LIST.....	42
	LIST OF FIGURES.....	6

LIST OF FIGURES

1. Phase Sequence Diagram.....	12
2. Phase Block Diagrams.....	13
3. Cut Cancellations.....	15
4. Phase Block Diagrams After Cut Cancellation.....	16
5. Candidates for Pseudo-Component Expansion.....	18
6. Transformed Phase Block Diagrams.....	21
7. Transformed and Simplified Phase Block Diagrams.....	23
8. Pseudo-Component Reliabilities.....	26
9. Relevant Phases.....	28
10. Block Diagram of Objective 2.....	29
11. Pivotal Decomposition.....	33
12. Reduction Into Modules.....	35
13. Successful Mission Outcomes.....	38
14. Mission Success Levels.....	40

I. INTRODUCTION

In a phased mission, the functional organization of the system changes during consecutive time periods. Some examples of systems which are required to perform a phased mission are space vehicles, public safety systems, and military weapons systems. Reliability analysis for a phased mission encounters complexities not present with just a single phase, since the performance of a particular component in one phase of a mission is not necessarily independent of its performance in another phase. In a recent paper, Bell [1975] modified and extended existing methods for the analysis of phased missions, so as to include an operational readiness (OR) phase, during which the system functions solely to maintain its readiness for later phases of active operation. The results were then extended to systems which perform complex multi-objective missions. This type of model is particularly applicable to strategic weapons systems.

The work in this paper follows very closely the work of Bell [1975]. An example is analyzed, largely with graphical techniques and diagrams, so as to avoid the complicated mathematics which were required in the development of the methodology of phased mission reliability analysis.

II. THE SLBM SYSTEM

A hypothetical submarine-launched ballistic missile system (SLBM), which was motivated by the Navy's Fleet Ballistic Missile system, was introduced by Bell [1975]. That hypothetical system is extended in this example to include three missiles, each of which has a different objective.

The SLBM system consists of the following components:

- the submarine (S) which provides propulsion, stability, power, and household services.
- the inertial navigation subsystem (N) which provides information on platform position and orientation.
- the communication subsystem (C) which provides the link between the submarine and its command center.
- the fire control subsystem (FC) which provides trajectory information to each missile guidance computer.
- the ejection subsystems (E1,E2,E3), one for each missile, which launch the missiles from the submarine while the latter is submerged.
- the guidance component of each missile (G1,G2,G3) which computes and transmits to the rocket engines the control commands required to maintain the trajectory stored within its memory, and triggers stage separation.
- two internal power sources for each missile (VP1 and VS1, VP2 and VS2, VP3 and VS3).
- the first- and second-stage rocket engines of each missile (RF1 and RS1, RF2 and RS2, RF3 and RS3).
- two first-stage igniters for each missile (IP1 and IS1, IP2 and IS2, IP3 and IS3).
- the second-stage igniter of each missile (J1, J2,

J3).

- the warhead of each missile (W1, W2, W3).

The SLBM system has an operational readiness (OR) phase, followed by five active phases for each objective. The operational characteristics of the system can be summarized as follows:

- During the OR phase the submarine patrols its assigned area, maintaining current position information with the inertial navigation subsystem. Should the inertial component fail, then position information can be obtained periodically from a navigation satellite, which provides the data necessary for calibration after repairs are completed. The communication subsystem is used continually during this phase for routine ship-shore message traffic. The fire control subsystem is exercised periodically during the OR phase to monitor its status. Similarly, the performance of the missile power sources and guidance components are checked through routine tests. All components which are monitored can be repaired or replaced if found to be failed during the OR phase. Other failures go undetected. In order for the system to be ready to commence active operations, it must have submarine services and current navigation information available, and it must be able to receive the launch command via the communication subsystem.

- The fire control phase for the first objective commences when a launch command is received. All maintenance actions cease, and launch preparations commence. The fire control subsystem transmits trajectory data to the guidance component of the first missile, and the submarine is positioned for launch. The fire control phases for subsequent objectives proceed in succession.

- During the launch phase for each missile, the submarine is held stable while the missile is ejected, severing its link with the platform and causing it to switch to internal power. The power sources, although activated,

are not required to supply power during this phase.

- The booster phase starts when the first-stage engine ignites. This occurs as each missile breaks through the surface of the water. The missile is then boosted along its trajectory. The port igniter can be powered only by the port power source, and the starboard igniter only by the starboard power source, but one igniter is sufficient to fire the engine. The guidance component, which can take power from either source, must function throughout the phase.

- During the flight phase, the second-stage igniter, second-stage engine, guidance component, and at least one power source must function.

- Shutdown of the second-stage engine marks the beginning of the terminal phase during which the warhead follows a ballistic trajectory to its target.

III. PROBLEM ANALYSIS

There are two goals in this example. The first is to determine the reliability of the SLBM system with respect to each particular objective, that is, the probability that each target is destroyed. The second goal is to analyze the overall success of the total mission.

A. PHASE SEQUENCE DIAGRAM

As a tool in the analysis of this example, the phase sequence diagram is used. For the SLBM system, the phase sequence diagram is shown in Fig 1. It graphically depicts the organizational sequence and numbering of phases. Each phase is numbered with two digits. For example, the launch phase of the first missile, which has objective 1, and is active phase 2, is numbered phase 12. Following phase 12, the phase sequence continues simultaneously up the first branch for objective 1, and along the trunk for successive objectives.

B. PHASE BLOCK DIAGRAMS

The functional organization of components within each phase of the mission is graphically represented by a block diagram. For each phase, the block diagrams which correspond to the description of the operational characteristics of the SLBM system are shown in Fig. 2.

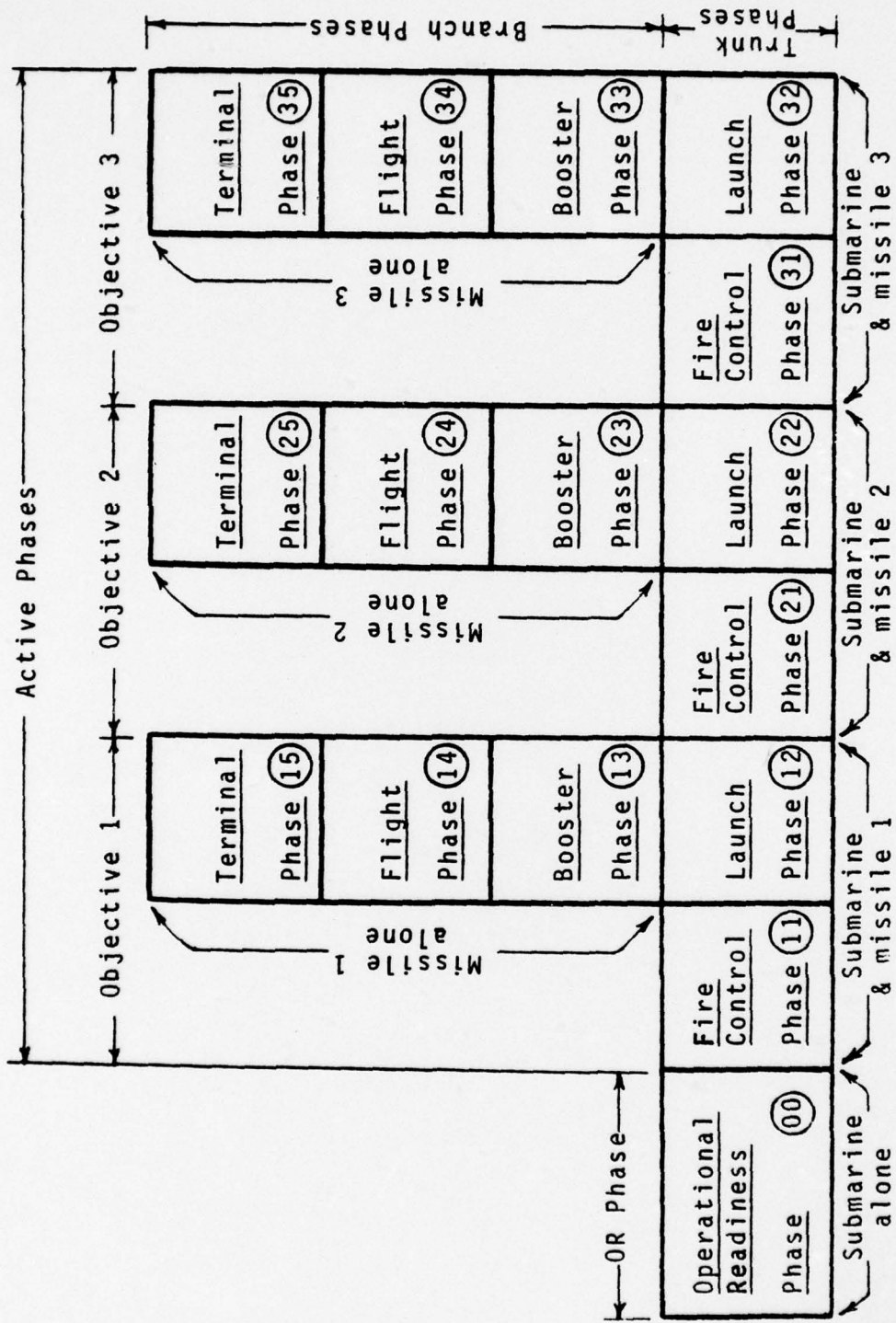


Figure 1 - PHASE SEQUENCE DIAGRAM

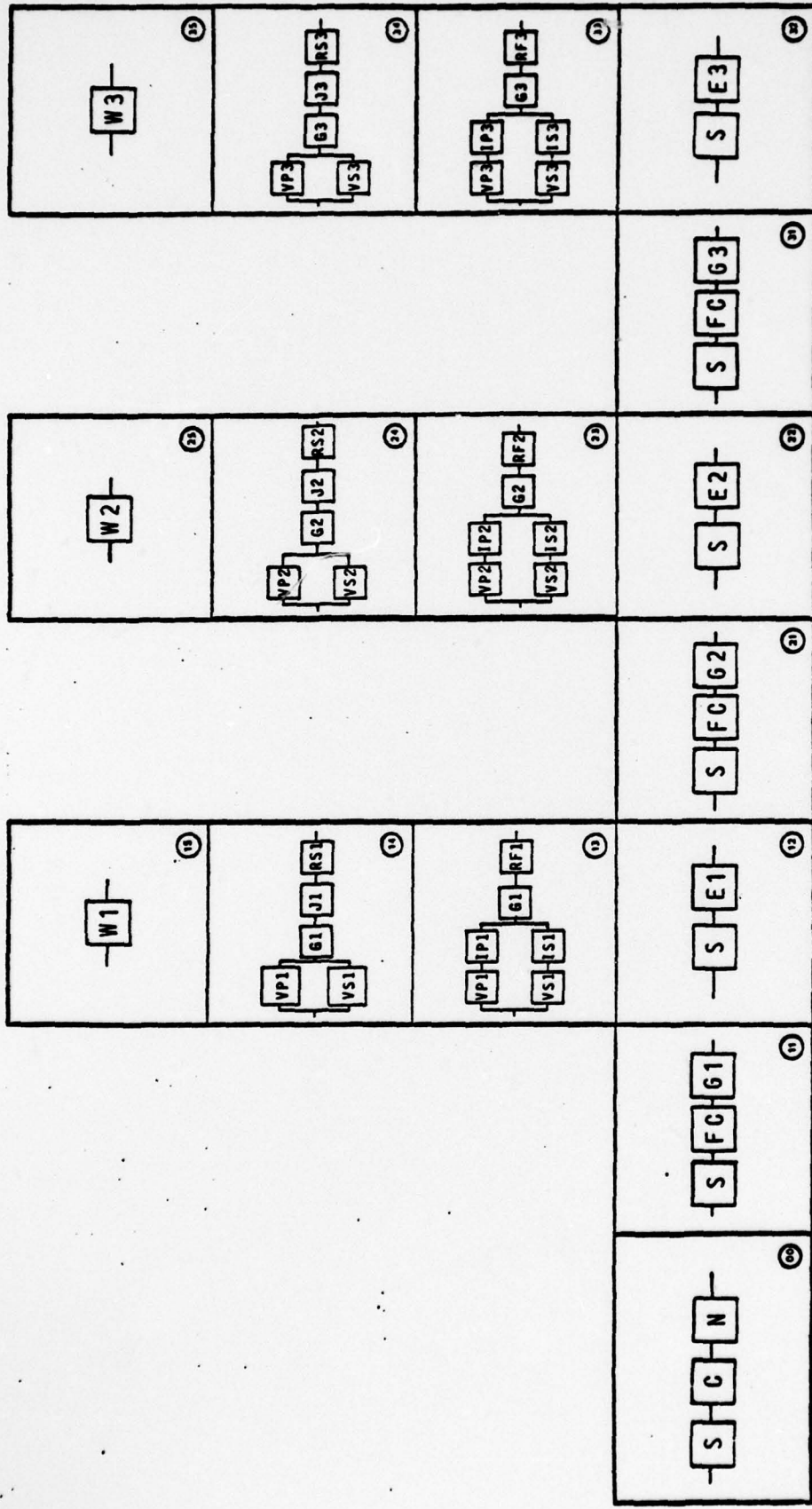


Figure 2 - PHASE BLOCK DIAGRAMS

1. Cut Cancellation

It is desirable, at this point, to simplify the block diagrams by a procedure, suggested by Rubin [1964] and Weisburg and Schmidt [1966], called **cut cancellation**. The cancellations which are permitted by this technique are shown in Fig 3. A simple rationale for these cancellations can be illustrated referring to Fig 3. For example, it can be seen that component G1 is required in the flight phase of objective 1 (phase 14), and that if it is not functioning through the end of that phase, objective 1 can not be accomplished. It can be reasoned that since the requirement that G1 functions in phase 14 includes the requirement that it does not fail in phases 11 or 13, G1 can therefore be eliminated from further consideration in those earlier phases. It is said that G1 first becomes relevant in phase 14.

A somewhat more complex situation occurs in the case of the submarine (component S), which is required for all three objectives. With respect to objective 1, S first becomes relevant in phase 12; with respect to objective 2, in phase 22; and with respect to objective 3, in phase 32. Cut cancellation is thus permitted, for component S, in phases 00, 11, 21, and 31.

The resulting block diagrams, following cut cancellation, are shown in Fig. 4.

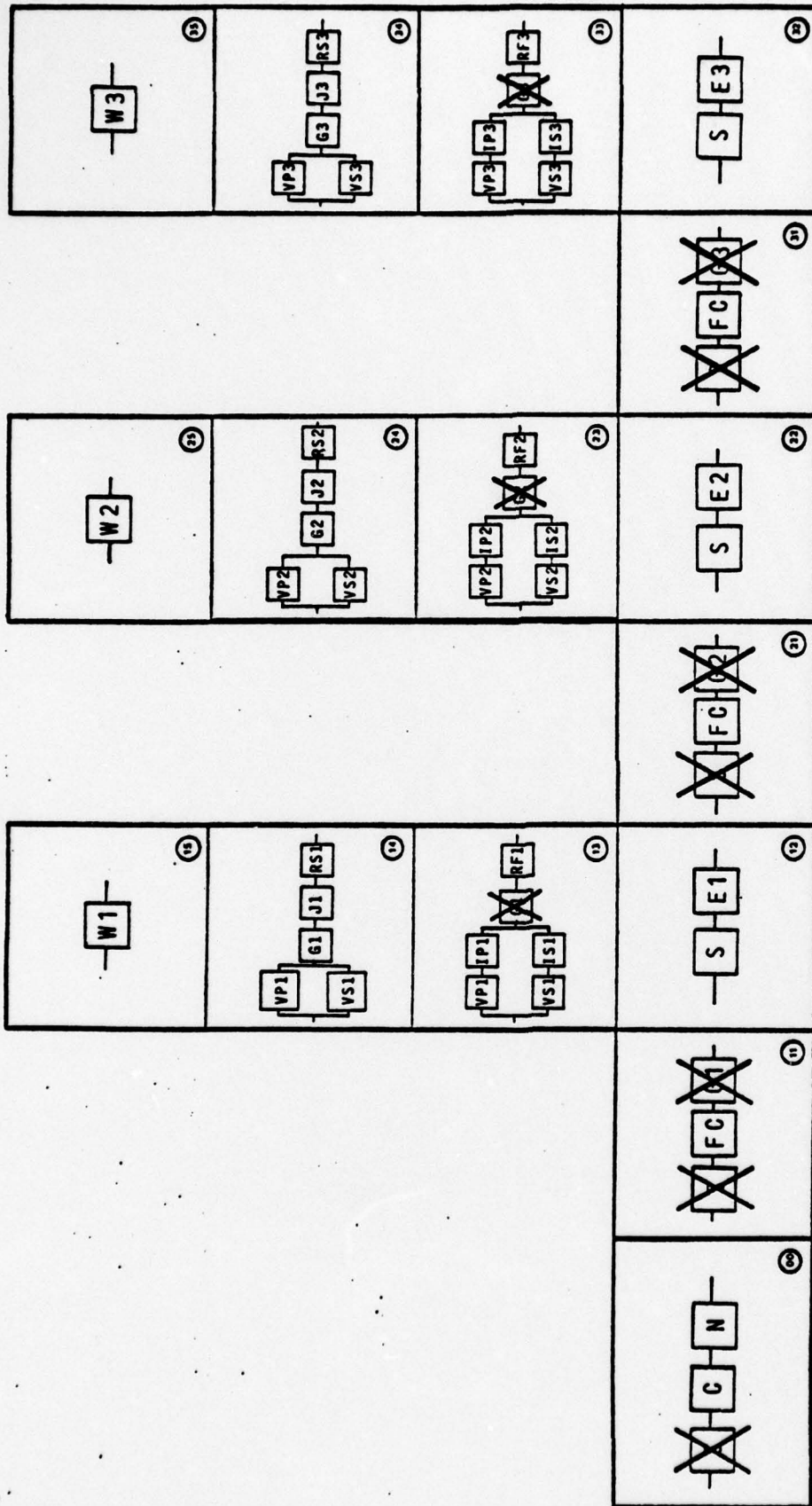


Figure 3 - CUT CANCELLATIONS

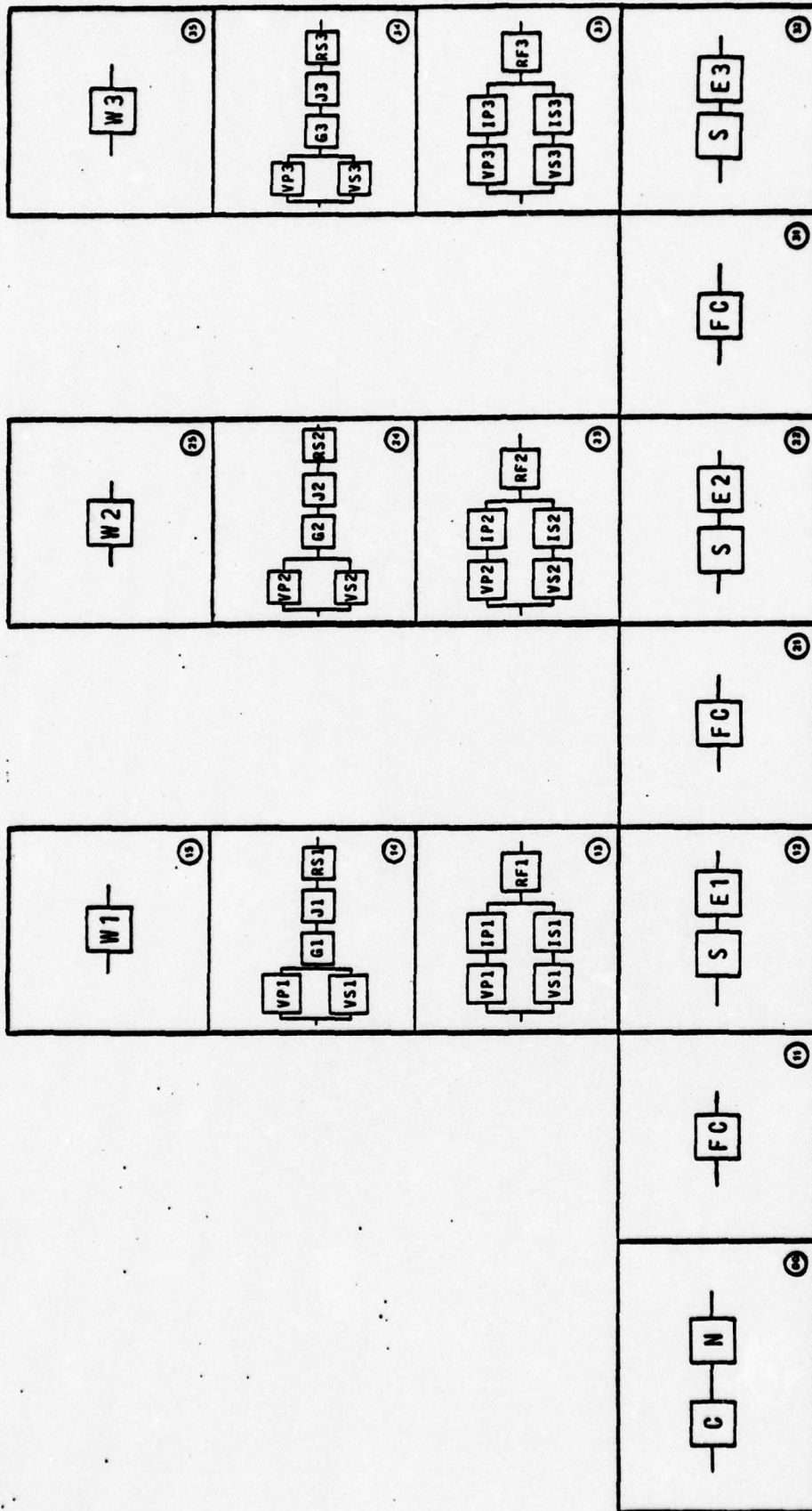


Figure 4 - PHASE BLOCK DIAGRAMS AFTER CUT CANCELLATION

2. Transformation of the Multi-phase Objective

The essence of the analysis of phased mission reliability lies in the technique, suggested by Esary and Ziehms [1975], of transforming a system with several phases into an equivalent, synthetic, single-phase system. This procedure makes it possible to compute reliability by standard methods.

In-as-much as the performance of each component in a particular phase is dependent on the performance in earlier phases, the transformation involves replacing original components with pseudo-components which represent performance in each phase independent of performance in all other phases.

A shortcoming of this technique is that the transformation generates a large number of pseudo-components, which may be unwieldy. Recognizing this, Bell [1975] suggested a procedure for the reduction of pseudo-components in a manner which retains the desirable characteristics of the transformation.

The procedures of Esary and Ziehms [1975] and Bell [1975] are modified for direct graphical application as follows:

a. Having already performed cut cancellation, which resulted in the phase block diagrams of Fig 4, identify components which appear in more than one phase. In the SLBM system, they are PC, S, VP1, VS1, VP2, VS2, VP3, and VS3. Now, as shown in Fig 5, circle the second and subsequent appearances of each of those components. These are the candidates for pseudo-component expansion.

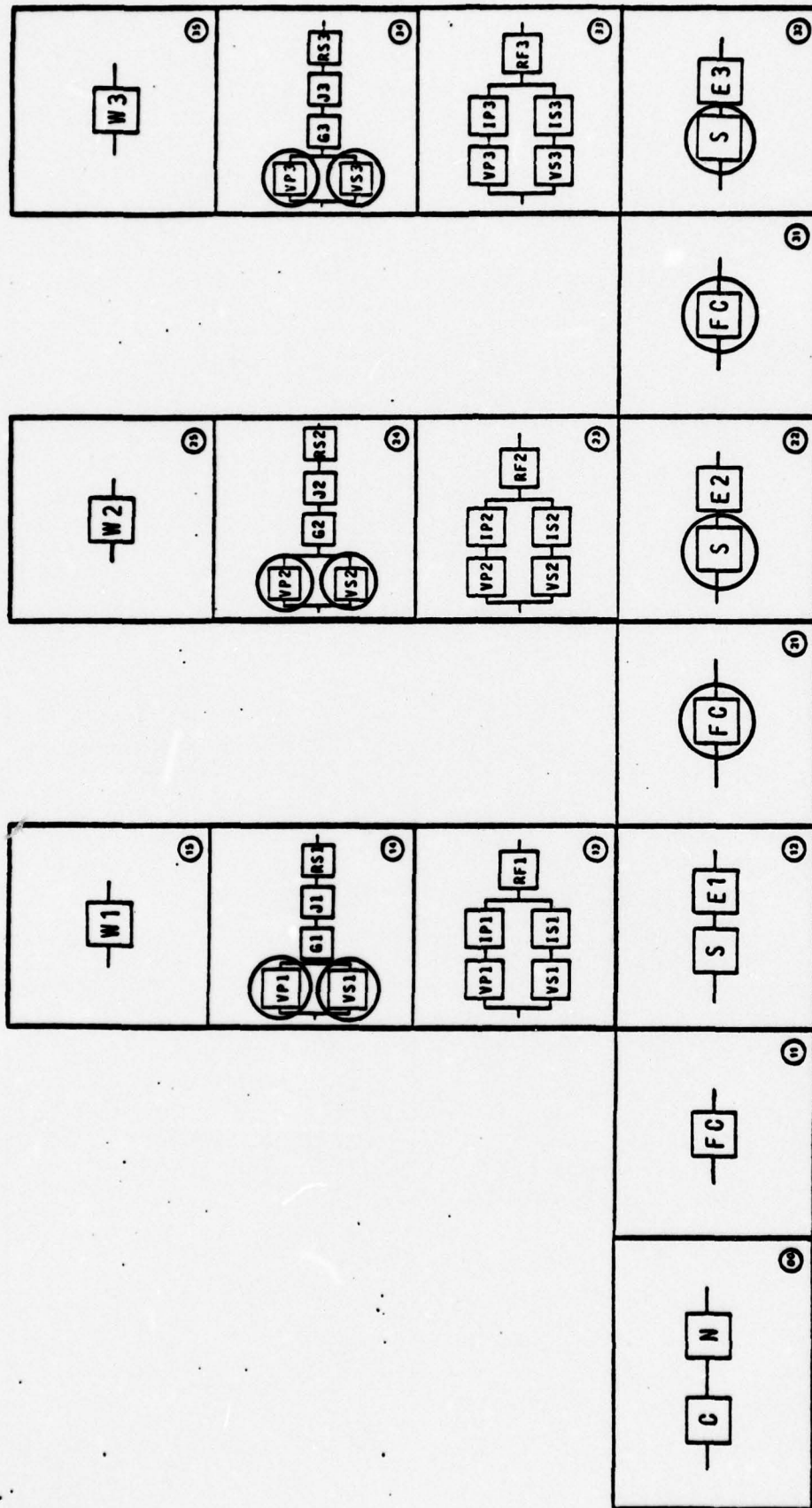
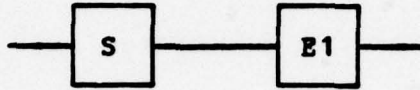


Figure 5 - CANDIDATES FOR PSEUDO-COMPONENT EXPANSION

b. Replace each of the uncircled components with a pseudo-component numbered with the phase number where it first appears. For example, replace the blocks



in phase 12, with the blocks

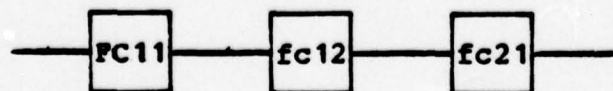


Each of these blocks now specifically represents a pseudo-component which is required to survive only through the end of the phase with which it is numbered.

c. Replace each of the circled components with an equivalent series arrangement of independent pseudo-components. Use lower case letters plus phase numbers to represent a pseudo-component which is required to function only during one phase. This step in the procedure, referred to as pseudo-component expansion, is best illustrated by the following example: The block



is replaced in phase 21 by



It should be clear that the series arrangement of FC11, which functions only through the end of phase 11, fc12, which functions only during phase 12, and fc21, which functions only during phase 21, is the equivalent, in phase 21, to the original component FC functioning through the end of that phase. It should also be clear that the pseudo-components are independent of one another. The results of transforming the phase block diagrams are shown in Fig 6.

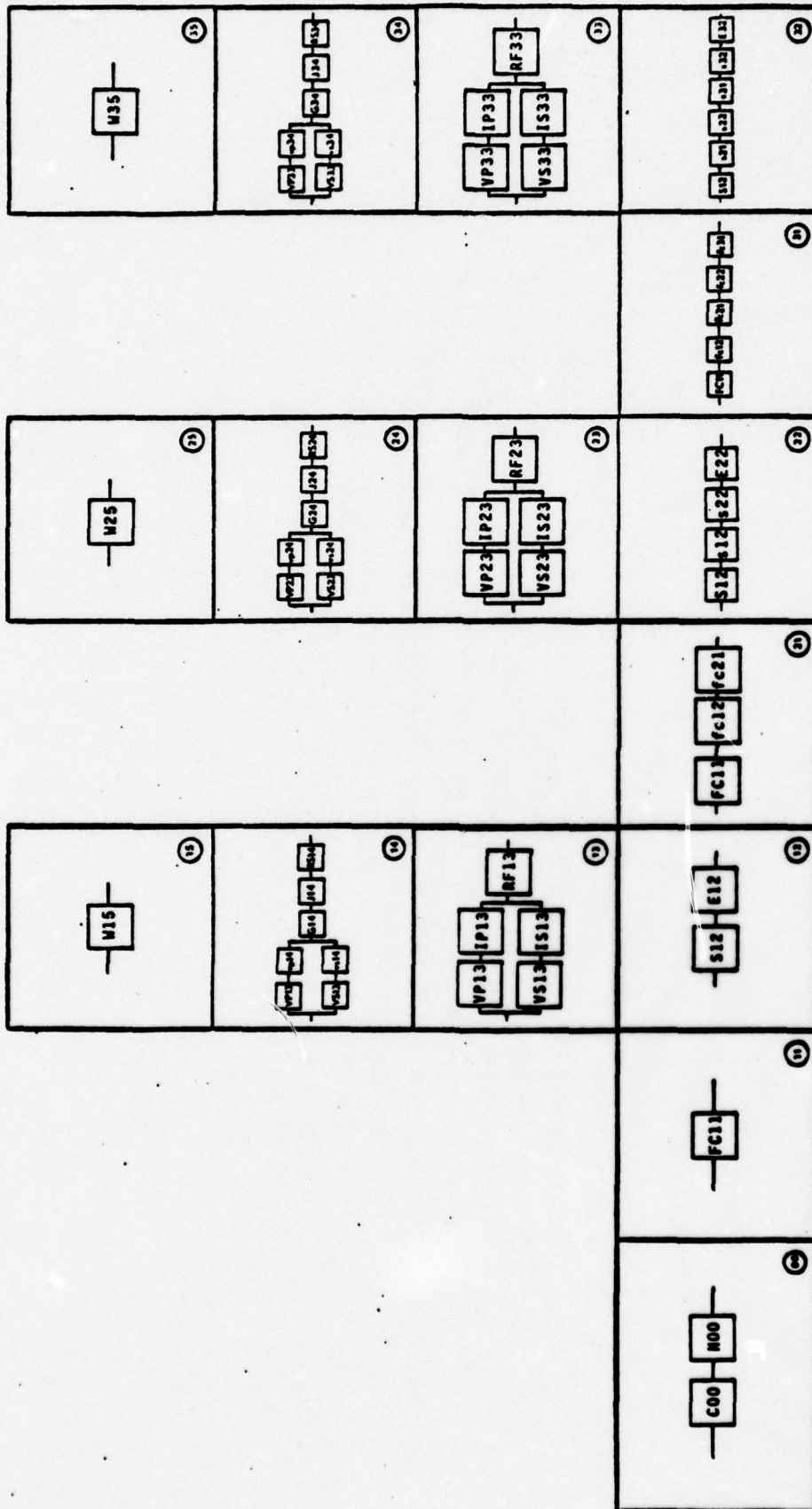
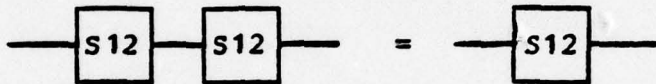


Figure 6 - TRANSFORMED PHASE BLOCK DIAGRAMS

3. Simplification

The phase block diagrams can now be connected to each other, in series, to create synthetic, equivalent, single-phase systems. However, before proceeding, it is desirable to simplify the block diagrams utilizing a procedure properly known as **idempotent cancellation**. This can be done wherever a particular block will appear in series with itself. Graphically, the idempotent law says, for example, that



The procedure for simplification is as follows:

a. Referring to Fig 6, identify those pseudo-components, and those particular groups of pseudo-components, which would be in series with themselves if successive transformed phase block diagrams were connected in series. These are candidates for simplification. In the SLBM system, they are S12, s21, s22, FC11, fc12, and fc21. Note that VP13, for example, is not a candidate since it is in distinct and different groups of pseudo-components in phases 13 and 14.

b. Remove the second and subsequent appearances of each of the candidates. The resulting transformed and simplified phase block diagrams are shown in Fig 7.

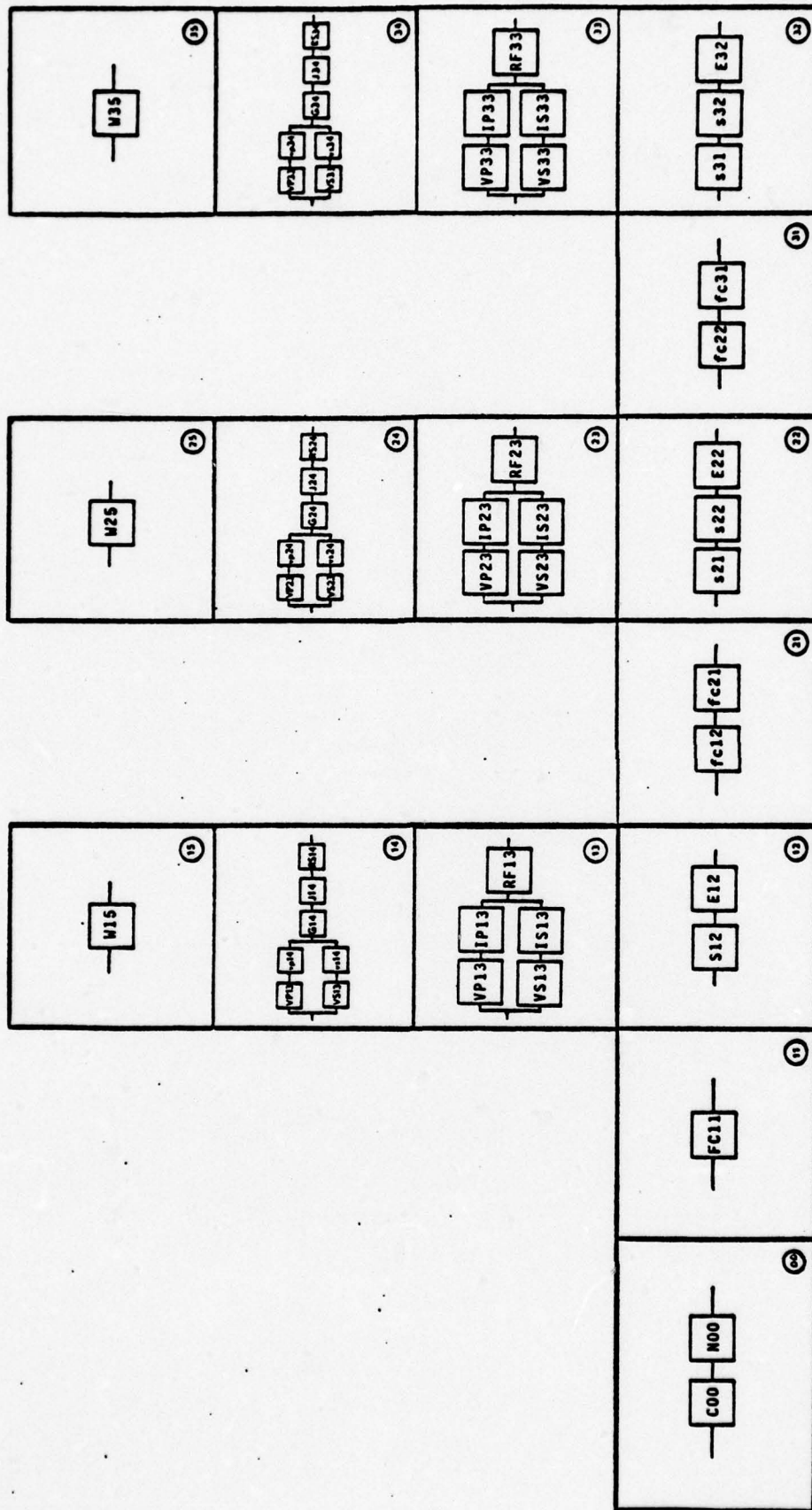


Figure 7 - TRANSFORMED AND SIMPLIFIED PHASE BLOCK DIAGRAMS

It should be noted that following this simplification, the transformed phase block diagrams are no longer, phase-by-phase, exact equivalents of the original phase block diagrams. However, when combined in series, as is done in a subsequent step, the resulting synthetic, single-phase systems are equivalent to the original multi-phase systems.

C. RELIABILITY OF PSEUDO-COMPONENTS

The first goal in this SLBM example, as stated earlier, is to determine the reliability of the system with respect to each particular objective; that is, the probability that each target is destroyed. In order to proceed, it is first necessary to discuss the reliability of the pseudo-components.

1. Conditional Component Phase Reliability

Represented by either upper case or lower case letters, the two different types of pseudo-components have reliabilities which are of different and distinct natures. For the pseudo-components represented by lower case letters, the reliability is the probability that the pseudo-component will function only during the particular phase indicated. Thought of another way, it is the conditional probability that the original component will function during that particular phase, given that it was functioning at the start of that phase. This conditional probability is referred to as conditional component phase reliability.

2. Unconditional Component Reliability

The reliability of the pseudo-components represented by upper case letters is the probability that the pseudo-component survives through the end of the particular phase indicated. This is the equivalent of the unconditional probability that the original component survives through the end of the first phase in which it is relevant. This unconditional probability is referred to as **unconditional component reliability**. It might be noted that the availability of each component at the commencement of active operations is included in the unconditional component reliability.

Hypothetical values for the reliability of each of the pseudo-components are shown in Fig 8 next to each respective block.

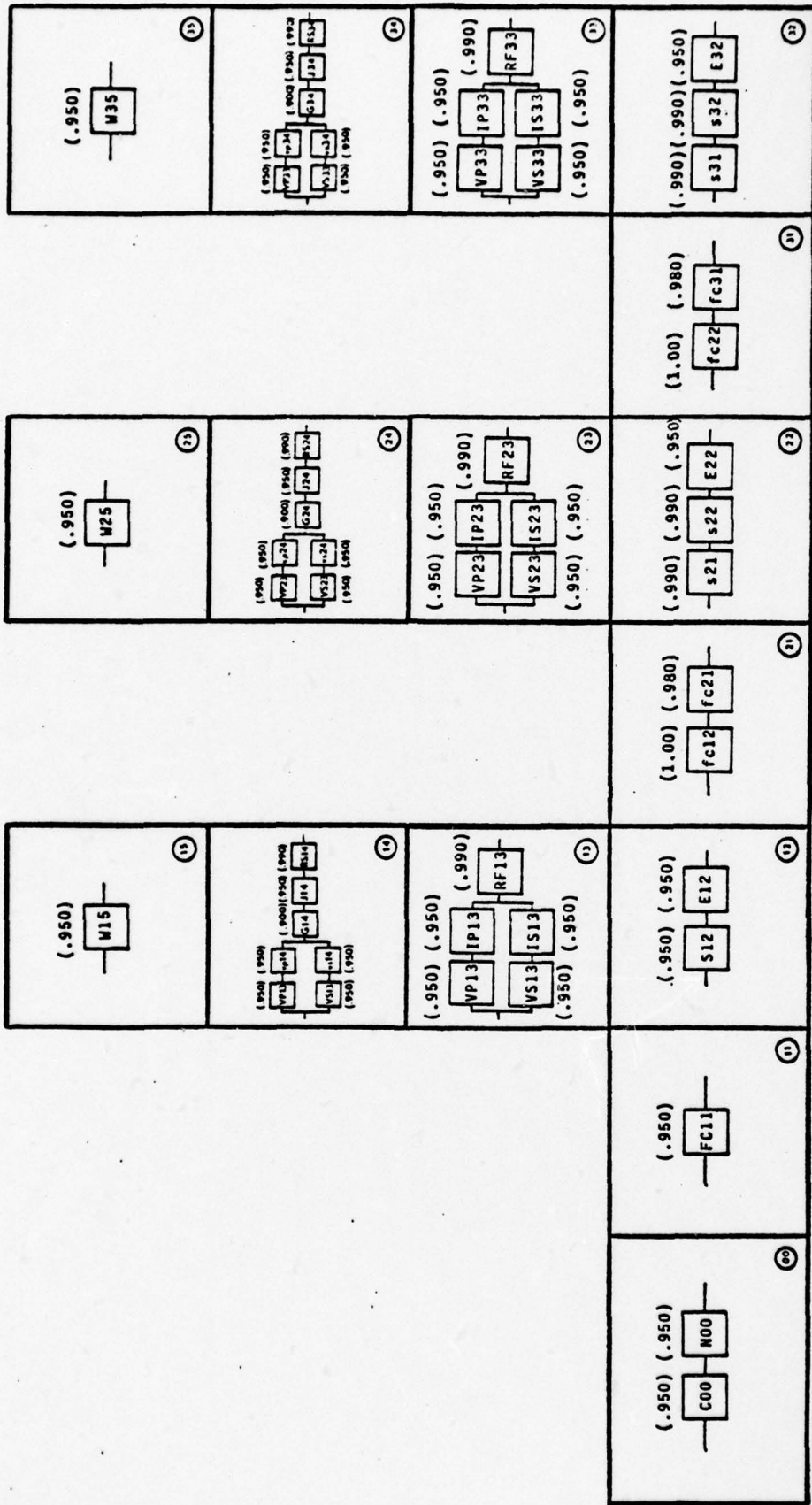


Figure 8 - PSEUDO-COMPONENT RELIABILITIES

D. OBJECTIVE RELIABILITY

The reliability of the SLBM system with respect to each objective can be determined by working with the transformed and simplified phase block diagrams of Fig 8. The procedure consists of two parts: the first is construction of the synthetic, equivalent, single-phase block diagram of pseudo-components for each objective; the second part is evaluation of the objective reliability using the block diagram and given values for pseudo-component reliabilities.

1. Objective Block Diagrams

The procedure for constructing the objective block diagrams is actually a continuation of the transformation process, and consists of the following steps:

a. Identify the sections of the phase sequence diagram which are relevant to each objective. This step is illustrated in Fig 9, the shaded portions of the phase sequence diagrams representing the relevant phases.

b. Connect, in series, the transformed phase block diagrams of all of the identified phases to form the objective block diagram. For example, the block diagram of objective 2 is shown in Fig. 10.

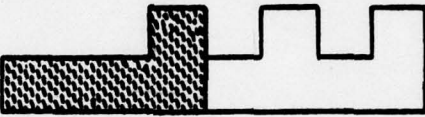
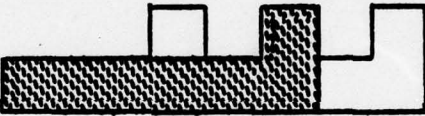
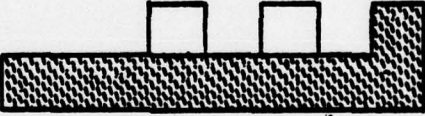
Objective	Phase Sequence Diagram
1	
2	
3	

Figure 9 - RELEVANT PHASES

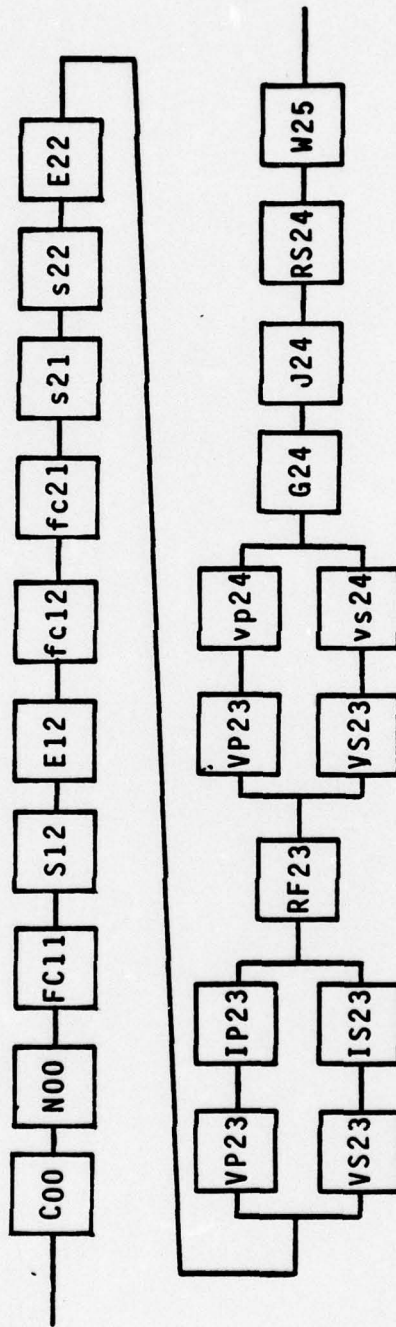


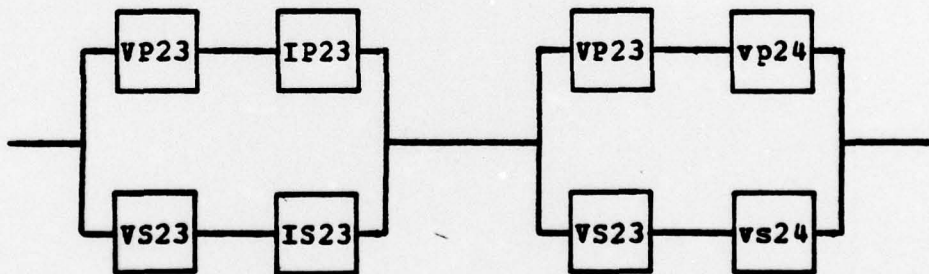
Figure 10 - BLOCK DIAGRAM OF OBJECTIVE 2

2. Objective Reliability Evaluation

Due to the presence of some pseudo-components more than once (for example, VP23 and VS23 in Fig 10), the objective block diagrams can not simply be treated as a series of independent modules, which would have made numerical evaluation straight-forward. As an alternative, it is possible to employ a well-known graphical technique of structural reliability, which is based on a procedure called pivotal decomposition (see, for example, Barlow and Proschan [1975]).

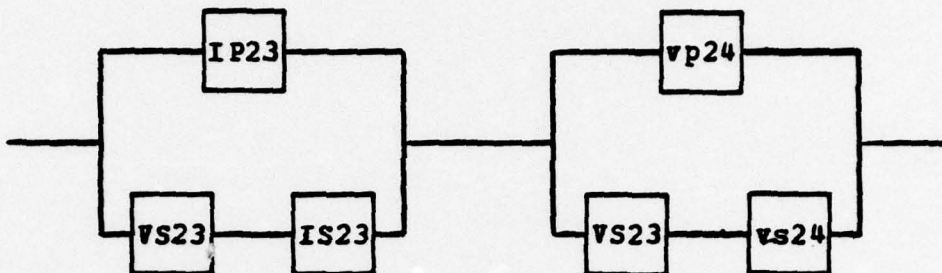
This technique is best illustrated by example, and consists of the following steps:

a. Pull all of the independent blocks to the front of the block diagram. In Fig 10, these are C00 through E22, RP23, and G24 through W25. This leaves the dependent sections, which in the case of objective 2 are



b. Pivot on one of the pseudo-components which cause the dependence, say VP23. To accomplish this, split the block diagram into two branches by considering the block diagrams which result if

(1) VP23 always functions:

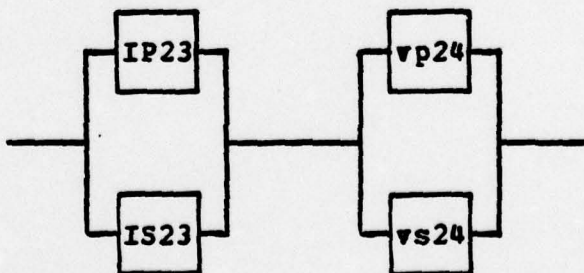


(2) VP23 always fails:



c. Since dependence still remains in the "VP23 always functions" branch, pivot again, this time on VS23. Split the "VP23 always functions" branch into two branches by considering the block diagrams which result if, in addition to VP23 always functioning

(1) VS23 always functions:



(2) WS23 always fails:



Since all branches now contain independent modules, no more pivoting is required. The result of these steps is illustrated in Fig 11. As shown in the figure, just beyond each pivot point and just below the branch lines, label each branch by a description of the event along that branch, such as "VP23 functions."

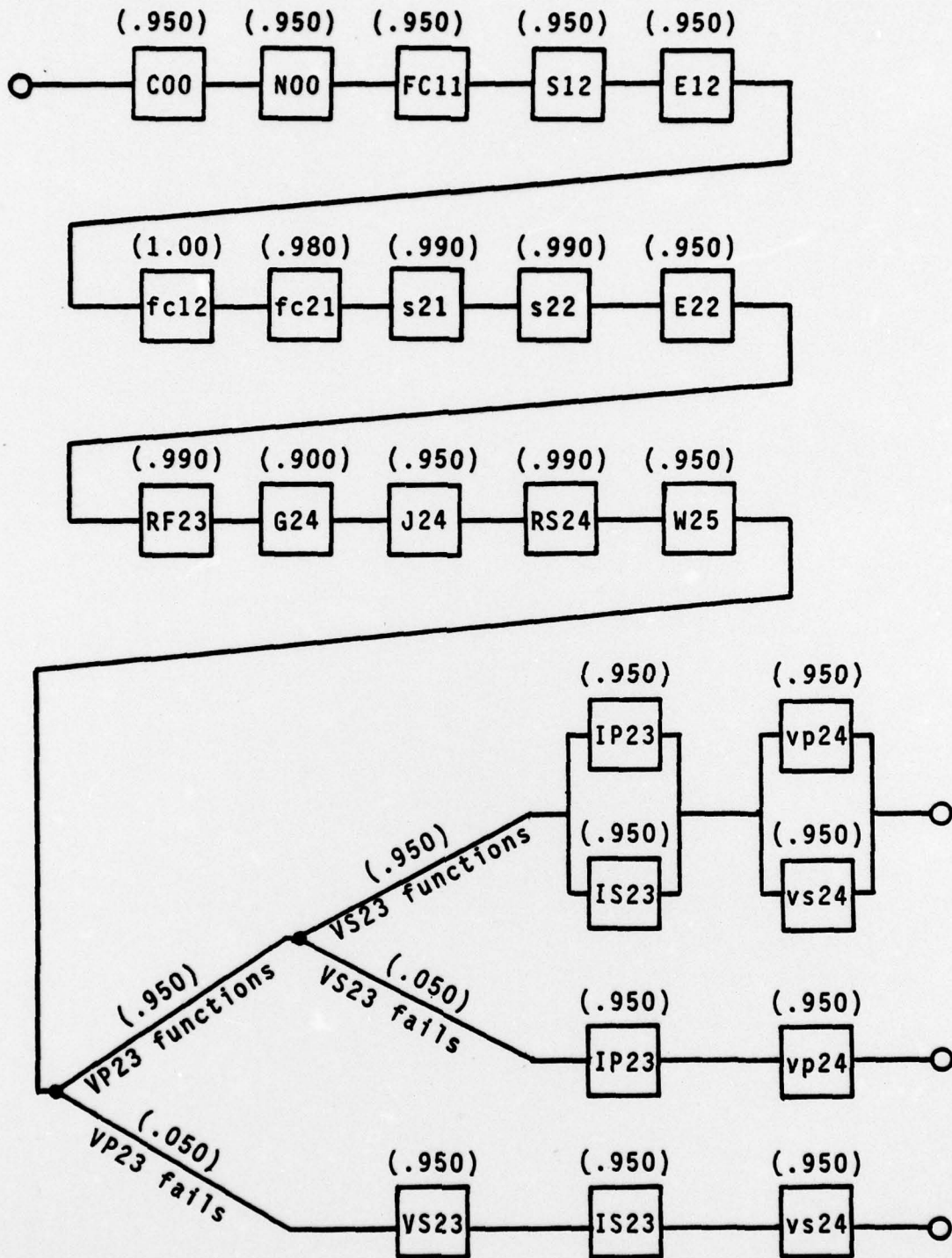


Figure 11 - PIVOTAL DECOMPOSITION OF OBJECTIVE 2
BLOCK DIAGRAM

d. Above each branch line, in parentheses, write the probability of the occurrence of the event along that branch. For example, the probability that VP23 functions is just its reliability, and the probability that it fails is one minus the reliability.

e. Above each pseudo-component block, write the probability of that block functioning' (the reliability of the pseudo-component).

f. The blocks in Fig 11 can be reduced into modules to simplify subsequent calculations. This is shown in Fig 12, where modules are indicated by dotted lines, and the reliability of each module is indicated in parentheses.

g. Multiply all of the probabilities (reliabilities) leading to the end of each branch, and write down the product. This is illustrated in Fig 12 by the numbers in brackets.

h. The reliability of objective 2, denoted by R2, can now be written down by summing the probabilities of all of the branches. Thus

$$R2 = .553$$

Similarly, the reliabilities of objectives 1 and 3 can be obtained. The results are:

$$R1 = .606$$

$$R3 = .505$$

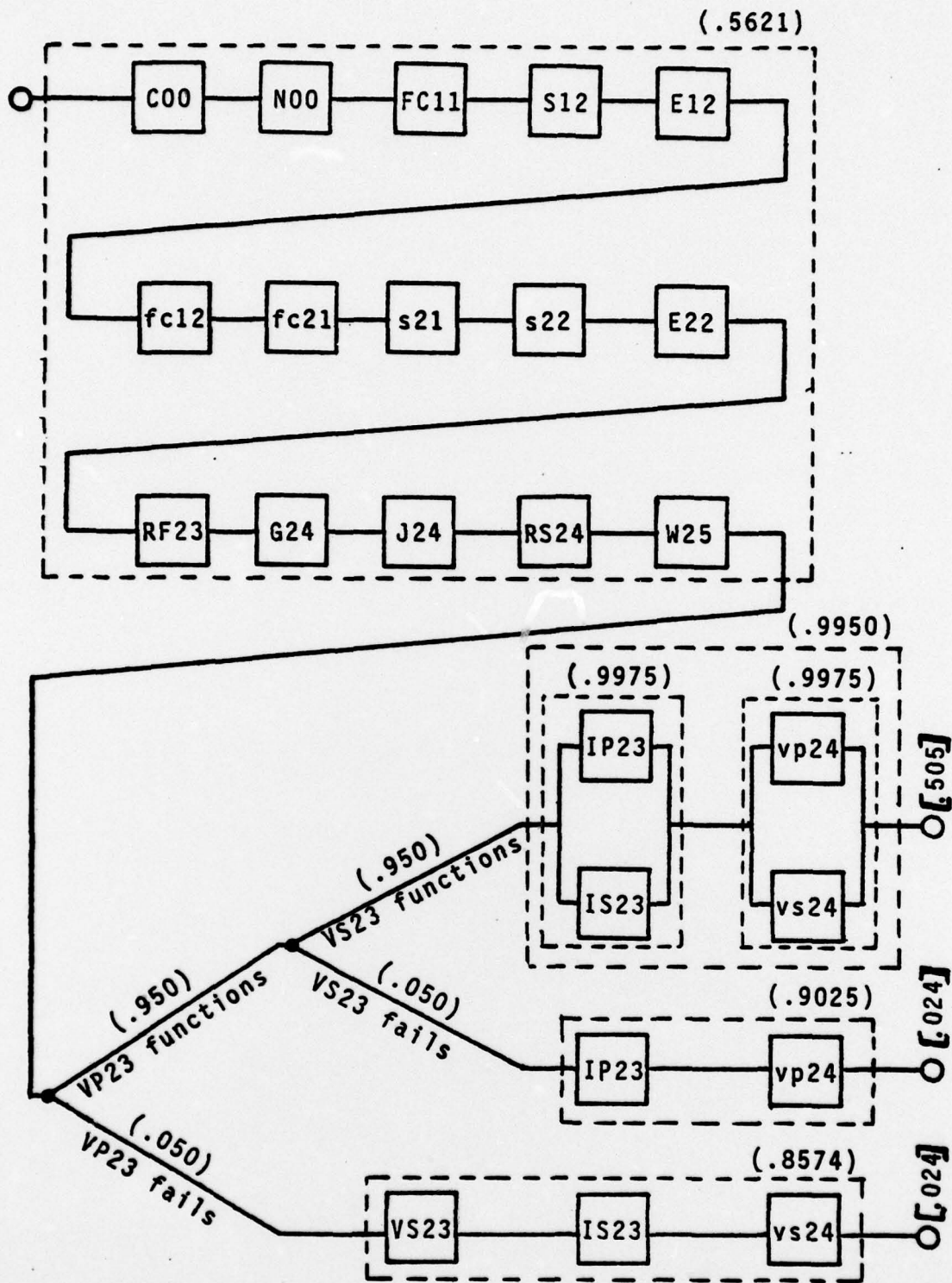


Figure 12 - REDUCTION INTO MODULES

E. MISSION SUCCESS

Having determined the reliability or probability of accomplishing each objective, the final goal is to analyze the overall success of the total mission. This aspect of the analysis may be achieved by answering the following questions:

(1) What is the probability that any particular number of objectives are accomplished on a mission?

(2) What is the expected or average number of objectives that will be accomplished per mission?

1. Successful Mission Outcomes

To begin answering these questions, first the possible successful outcomes of a mission must be considered. The accomplished objectives could be:

- objective 1 alone
- objective 2 alone
- objective 3 alone
- objectives 1 and 2
- objectives 1 and 3
- objectives 2 and 3
- objectives 1, 2, and 3

The probability of accomplishment, or reliability of each objective alone has already been determined. Following the same procedures which produced R1, R2, and R3, the joint objective reliabilities can be found. It should be noted

that in set theory terminology, the joint objectives are the intersections of the events which are single objectives. Determining joint objective reliabilities consists of the following steps:

a. Construct the joint objective block diagram by connecting, in series, the transformed and simplified phase block diagrams of the relevant phases, which in the case of joint objective 1 and 2, for example, are indicated by shading in the phase sequence diagram as follows:

b. Evaluate the joint objective reliability which is denoted in the case of joint objective 1 and 2, for example, as R_{12} .

The possible successful outcomes and the corresponding phase sequence diagrams are summarized in Fig 13. A convenient tool from set theory, the Venn diagram, is also shown for each outcome. The numerical values for objective and joint objective reliabilities in this example are also shown.

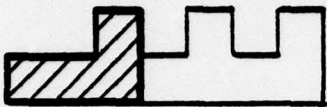

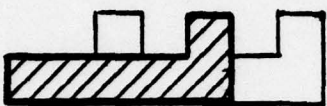
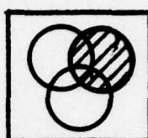

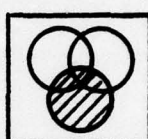
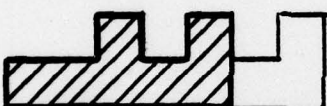

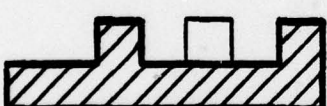
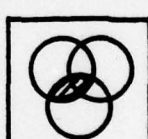

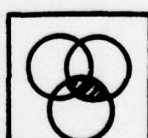

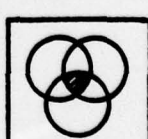
Objectives Accomplished	Phase Sequence Diagram	Reliability (Probability)		Venn Diagram
		Symbol	Numerical Value	
1		R_1	.606	
2		R_2	.553	
3		R_3	.505	
1,2		R_{12}	.433	
1,3		R_{13}	.395	
2,3		R_{23}	.395	
1,2,3		R_{123}	.309	

Figure 13 - SUCCESSFUL MISSION OUTCOMES

2. Mission Success Levels

The probability that any particular number of objectives are accomplished on a mission can be written down directly with the aid of the corresponding Venn diagrams. These quantities, which correspond to varying levels of mission success, are tabulated in Fig 14. It is noted that in a more general application, where Venn diagrams might not apply, other straight-forward approaches may be used (see Bell [1975], for example).



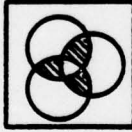

Number of Objectives Accomplished	Venn Diagram	Probability	
		In terms of (Joint) Objective Reliabilities	Numerical Value
none		$1 - (R_1 + R_2 + R_3 - R_{12} - R_{13} - R_{23} + R_{123})$.250
exactly one		$R_1 + R_2 + R_3 - 2R_{12} - 2R_{13} - 2R_{23} + 3R_{123}$.145
exactly two		$R_{12} + R_{13} + R_{23} - 3R_{123}$.296
exactly three		R_{123}	.309

Figure 14 - MISSION SUCCESS LEVELS

3. Expected Success

Using the probability of each mission success level, the average or expected number of successes per mission can be determined by weighing each number by its probability of occurrence and then adding. This is illustrated in the following result:

$$\begin{aligned} \text{Expected number} \\ \text{of objectives} \\ \text{accomplished} &= (0) (.250) + (1) (.145) \\ &\quad + (2) (.296) + (3) (.309) \\ &= \underline{1.66} \end{aligned}$$

Alternative measures of mission success could be examined in a similar manner. Particularly, objectives could be weighted as to importance, and specific combinations of accomplished objectives could be considered. Bell [1975], for example, suggested an approach which could be used in the case of a complex mission success criteria.

LIST OF REFERENCES

1. Barlow, R. E. and Proschan, F., Statistical Theory of Reliability and Life Testing. Holt, Rinehart, and Wilson, 1975.
2. Bell, Merlin G., Multi-Phase Mission Reliability of Maintained Standby Systems. NPS55Ey75121. Naval Postgraduate School, Monterey, Ca., 1975.
3. Esary, J. D. and Ziehms, H., Reliability Analysis of Phased Missions. In Reliability and Fault Tree Analysis. R. E. Barlow, J. B. Fussell, and N. D. Singpurwalla, editors. SIAM., 1975.
4. Rubin, J. C., The Reliability of Complex Networks. Proceedings of the Aero-Space Reliability and Maintainability Conference, 1964.
5. Weisburg, S. A. and Schmidt, J. H., Computer Technique for Estimating System Reliability. Proceedings of the 1966 Annual Symposium on Reliability. IEEE 7C26, 1966.

INITIAL DISTRIBUTION LIST

	No. Copies
1. Defense Documentation Center Cameron Station Alexandria, Virginia 22314	2
2. Library, Code 0212 Naval Postgraduate School Monterey, California 93940	2
3. Chairman, Code 55 Department of Operations Research Naval Postgraduate School Monterey, California 93940	2
4. Professor J. D. Esary, Code 55Ey Department of Operations Research Naval Postgraduate School Monterey, California 93940	1
5. Professor M. B. Kline, Code 54Kx Department of Administrative Sciences Naval Postgraduate School Monterey, California 93940	1
6. LT Steven E. Pilnick, USN RD 4, Box 60 Middletown, New York 10940	1