

AD-A035 812

NAVAL POSTGRADUATE SCHOOL MONTEREY CALIF
INSTRUMENT PACKAGE FOR MEASUREMENT OF SHIPBOARD RFI, (U)
OCT 76 A R SHUFF, J E OHLSON
NPS-620L76108

F/G 17/2.1

UNCLASSIFIED

NL

1 of 1
ADA035812

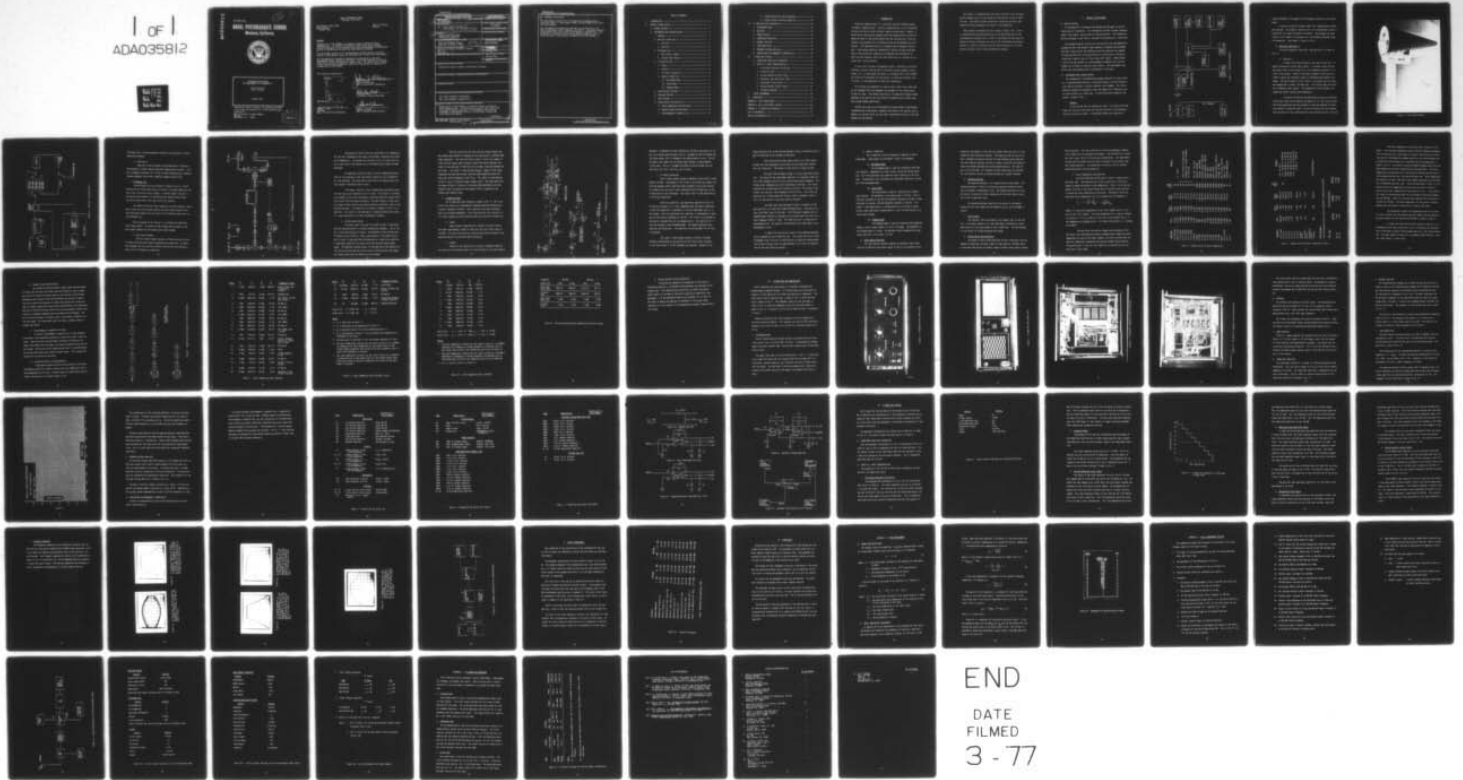

END
DATE
FILMED
3-77

ADA 035812

NPS-620L76108

Handwritten initials/signature

NAVAL POSTGRADUATE SCHOOL

Monterey, California

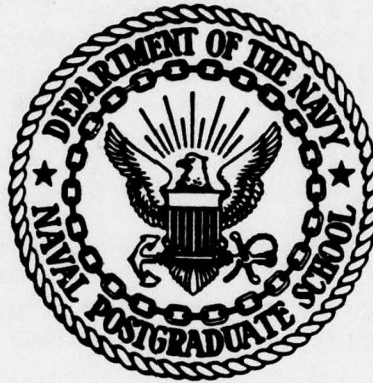

INSTRUMENTATION PACKAGE
FOR MEASUREMENT OF SHIPBOARD RFI

Allen Ray Shuff
John E. Ohlson

October 1976

Approved for public release: Distribution unlimited
A task under the Shipboard RFI in UHF SATCOM Project
Prepared for:
Naval Electronic Systems Command
PME 106
Washington, D.C. 20302

D D C
RECEIVED
FEB 22 1977
A

NAVAL POSTGRADUATE SCHOOL
Monterey, California

Rear Admiral Isham Linder
Superintendent
1 October 1976

Jack R. Borsting
Provost

ABSTRACT

Shipboard RFI to UHF SATCOM is a potential threat to effective Naval communications. To determine the extent of this threat and to develop corrective measures, it was necessary that tests be performed to characterize the RFI in the UHF band in which the Fleet Satellites operate.

The requirement existed for an instrumentation package having a low noise figure, a large dynamic range, and the capability of rapid field maintenance.

The instrumentation package was designed and constructed at the Naval Postgraduate School, Monterey, California. The design conforms to practices which lead to good electromagnetic compatibility. The design met all design criteria and has been successfully used in collecting data to characterize shipboard RFI to UHF SATCOM.

This report was prepared by:

ACCESSION NO.	
DTIC	UNCLASSIFIED
DDC	
UNANNOUNCED	
JUSTIFICATION	
BY	
DISTRIBUTION/AVAILABILITY STATEMENT	
Dist.	AVAIL. STATEMENT
A	

John E. Ohlson
Associate Professor
Dept. of Electrical Engineering

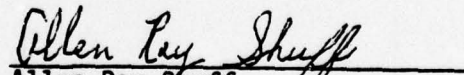
Allen Ray Shuff
Lieutenant, United States Navy

Approved by:

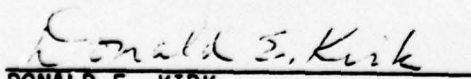
DONALD E. KIRK
Chairman
Dept. of Electrical Engineering

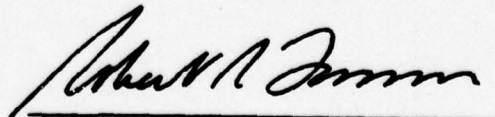
ROBERT R. FOSSUM
Dean of Research Administration

UNCLASSIFIED

SECURITY CLASSIFICATION OF THIS PAGE (When Data Entered)

REPORT DOCUMENTATION PAGE		READ INSTRUCTIONS BEFORE COMPLETING FORM
1. REPORT NUMBER NPS-620L76108	2. GOVT ACCESSION NO.	3. RECIPIENT'S CATALOG NUMBER
4. TITLE (and Subtitle) Instrument Package for Measurement of Shipboard RFI	5. TYPE OF REPORT & PERIOD COVERED Task Report	
7. AUTHOR(s) LT Allen Ray Shuff USN Prof John E. Ohlson	6. PERFORMING ORG. REPORT NUMBER	
9. PERFORMING ORGANIZATION NAME AND ADDRESS Naval Postgraduate School Monterey, California 93940	8. CONTRACT OR GRANT NUMBER(s)	
11. CONTROLLING OFFICE NAME AND ADDRESS Naval Electronic Systems Command PME 106 Washington, D.C.	10. PROGRAM ELEMENT, PROJECT, TASK AREA & WORK UNIT NUMBERS N0003976WRT9053	
14. MONITORING AGENCY NAME & ADDRESS (if different from Controlling Office)	12. REPORT DATE Oct 1976	
	13. NUMBER OF PAGES 73	
	15. SECURITY CLASS. (of this report) Unclassified	
	15a. DECLASSIFICATION/DOWNGRADING SCHEDULE	
16. DISTRIBUTION STATEMENT (of this Report) Approved for public release; distribution unlimited		
17. DISTRIBUTION STATEMENT (of the abstract entered in Block 20, if different from Report)		
18. SUPPLEMENTARY NOTES		
19. KEY WORDS (Continue on reverse side if necessary and identify by block number) RFI, Radio Frequency Interference EMC, Electromagnetic Compatibility		
20. ABSTRACT (Continue on reverse side if necessary and identify by block number) Shipboard RFI to UHF SATCOM is a potential threat to effective Naval communications. To determine the extent of this threat and to develop corrective measures, it was necessary that tests be performed to characterize the RFI in the UHF band in which the Fleet Satellites operate.		

14

6

10

1275 P.

11

(Continued)

DD FORM 1 JAN 73 1473

EDITION OF 1 NOV 65 IS OBSOLETE
S/N 0102-014-6601

UNCLASSIFIED

251 450

SECURITY CLASSIFICATION OF THIS PAGE (When Data Entered)

Contd

UNCLASSIFIED

SECURITY CLASSIFICATION OF THIS PAGE(When Data Entered)

20. ABSTRACT (Continued)

The requirement existed for an instrumentation package having a low noise figure, a large dynamic range, and the capability of rapid field maintenance.

The instrumentation package was designed and constructed at the Naval Postgraduate School, Monterey, California. The design conforms to practices which lead to good electromagnetic compatibility. The design met all design criteria and has been successfully used in collecting data to characterize shipboard RFI to UHF SATCOM.



UNCLASSIFIED

SECURITY CLASSIFICATION OF THIS PAGE(When Data Entered)

TABLE OF CONTENTS

I.	INTRODUCTION -----	3
II.	OVERALL SYSTEM DESIGN -----	5
	A. DESIGN CRITERIA -----	5
	B. INSTRUMENTATION PACKAGE DESIGN -----	5
	1. Antenna -----	5
	2. Deck Box I/Deck Box II -----	7
	a. Deck Box I -----	7
	b. Deck Box II -----	10
	3. RF/Blanker Box -----	10
	a. Main Signal Channel -----	10
	b. Blanker Gate Channel -----	12
	4. IF Amplifier Box -----	13
	a. Inputs -----	13
	b. Outputs -----	13
	c. IF Signal Processing -----	15
	d. Modes of Operation -----	17
	(1) Narrowband Mode -----	17
	(2) Record Mode -----	17
	(3) Wideband Mode -----	17
	5. Level Density Analyzer -----	17
	6. Spectrum Analyzer -----	18
	7. Oscilloscope -----	18
	8. System Design Considerations -----	18
	a. Noise Temperature Considerations -----	19
	b. Dynamic Range Considerations -----	23
	c. Electromagnetic Compatibility -----	23

d.	System Reliability and Maintenance -----	23
e.	System Internal Testing Capability -----	29
III.	IF AMPLIFIER BOX CONSTRUCTION -----	30
A.	INTERCONNECTIONS -----	30
B.	SWITCHES -----	35
C.	POWER SUPPLIES -----	35
D.	LOGARITHMIC AMPLIFIER -----	35
E.	MINIMAL LOSS PAD -----	36
F.	VIDEO AMPLIFIERS -----	36
G.	RECORDER VOLTAGE AMPLIFIER -----	38
H.	COOLING AND ELECTROMAGNETIC COMPATIBILITY -----	38
IV.	IF AMPLIFIER TESTING -----	45
A.	LOGARITHMIC AMPLIFIER CALIBRATION -----	45
B.	OUTPUT VS. INPUT CHARACTERISTICS -----	45
1.	Strip-Chart Recorder Calibration -----	45
2.	Linearity Check -----	47
3.	One dB Compression Point Check -----	47
4.	Additional Gain Amplifiers Check -----	49
5.	Selectable Filter Checks -----	49
6.	Analog Recorder Channel Checks -----	50
7.	Frequency Response -----	51
V.	ACTUAL PERFORMANCE -----	56
VI.	CONCLUSION -----	58
	APPENDIX A Noise Measurement -----	59
	APPENDIX B Daily Performance Testing -----	62
	APPENDIX C IF Operating Procedures -----	69
	LIST OF REFERENCES -----	71
	INITIAL DISTRIBUTION LIST -----	72

I. INTRODUCTION

Satellite communications is a relatively new and extremely promising mode of communications. Satellite communications is not influenced by nature as much as other long-haul communications modes. However, a factor which could greatly degrade satellite communications reliability among the ships of the United States Navy has received very little attention, as discovered by a literature survey at the beginning of this project. This degrading factor is shipboard radio frequency interference. Even though extensive shipboard RFI testing has been performed, most of the testing has centered on intermodulation problems at HF, while the UHF channels, where the fleet satellites will operate has received very little attention.

In July 1975, the Naval Postgraduate School in Monterey, California received a charter from the Naval Electronics Systems Command in Washington, D.C. to investigate and report on "Shipboard RFI in UHF SATCOM". The Principal Investigator for the project is Associate Professor John E. Ohlson, in the Department of Electrical Engineering.

This project was promoted by a need to have a definitive study made on the shipboard UHF electromagnetic environment of the surface ships of the U.S. Navy. The charter specifically included the frequency bands expected to be used by the Fleet Satellite Communications System, when that system becomes operational.

The RFI which was to be investigated included harmonic interference, intermodulation interference, wideband interference from sources such as welders or ignition noise, and any other interference falling in the band between 240 and 400 MHz.

This report is concerned with the overall design of the instrumentation package as well as the design and construction of the IF amplifier box. The overall system calibration, operation, and daily performance testing procedures are treated in the Appendices.

Other reports concerned with this project include: Ref. 1 which is concerned with the detailed design of the deck boxes used in the instrumentation package; Ref. 2, which is concerned with the detailed design of the RF and blanker box used in the instrumentation package; and Ref. 3, which is concerned with the detailed design of the level density analyzer used in the instrumentation package.

II. OVERALL SYSTEM DESIGN

A. DESIGN CRITERIA

The shipboard RFI instrumentation package was designed to provide three types of information. The information provided includes frequency domain, time domain, and statistical characterization. The information may be displayed in real time or recorded for evaluation at a later date.

The paramount design criteria was insuring that the instrumentation package had the large dynamic range necessary to measure the extremely low-level signals which the shipboard satellite receivers are capable of receiving and still not being driven into saturation by relatively large-level signals, such as line-of-sight UHF signals. Other design criteria include reliability, electromagnetic compatibility, and the capability to blank on large UHF radar signals. The requirement also exists that the system be easily maintained in the field.

B. INSTRUMENTATION PACKAGE DESIGN

The shipboard RFI instrumentation package consists of a test antenna, a superheterodyne receiver, a spectrum analyzer, an oscilloscope, a level density analyzer, a digital recorder, and a camera. The instrumentation package was designed to have the capability of adding an analog tape recorder at a later date. A simplified block diagram of the system is shown in Fig. 1.

1. Antenna

It was desired that the antenna be right - circularly polarized, since this would be consistent with the polarization of the shipboard satellite receivers antenna. A broad-band antenna was required to

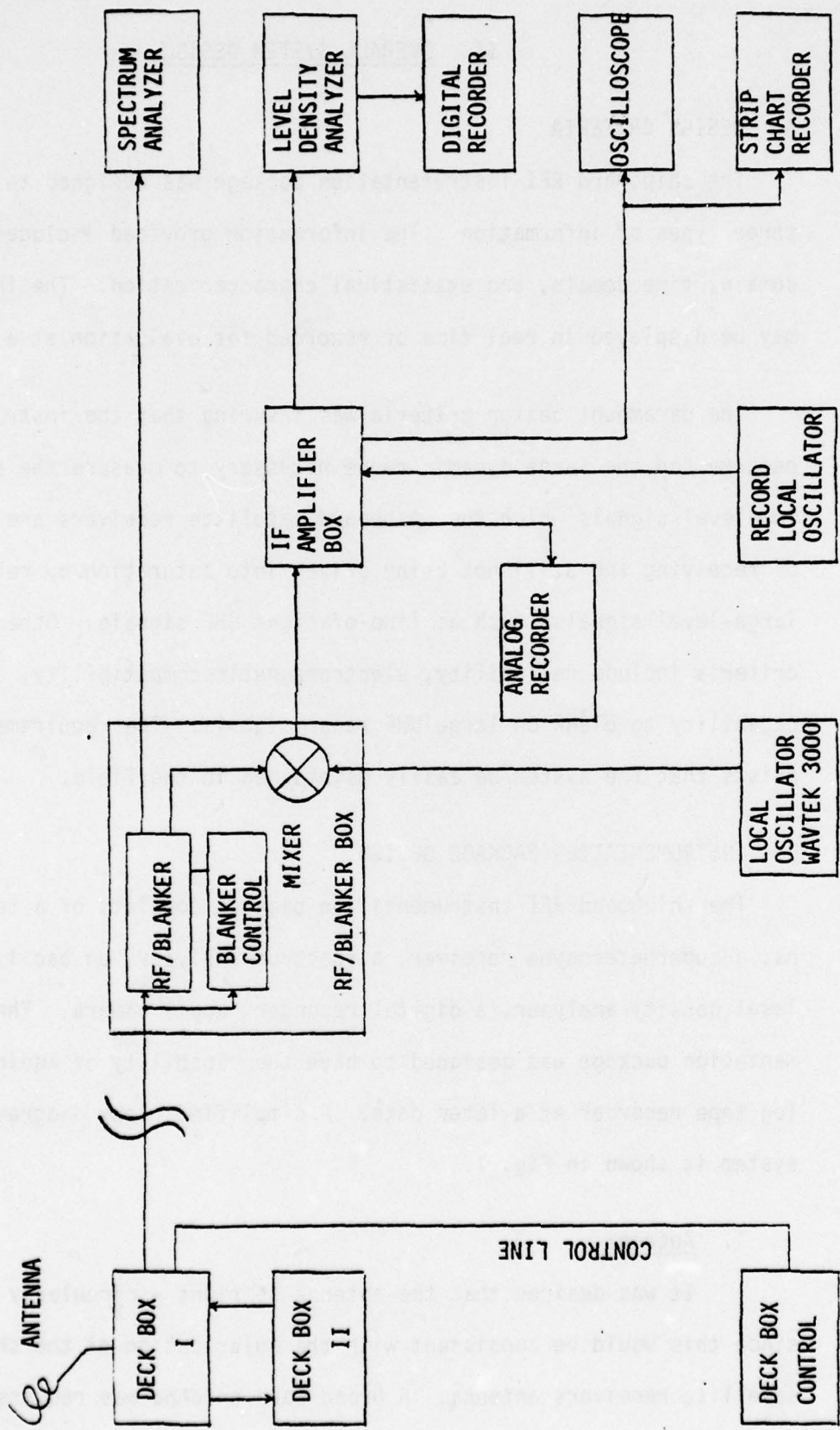

Figure 1. System Block Diagram

insure coverage of the segment of the frequency spectrum to be investigated.

A conical log-spiral antenna, Model 3101, manufactured by EMCO was procured. The antenna's mounting had to be restructured to make it durable for the rugged shipboard environment. The average 3 dB beamwidth of this antenna is 90 degrees over the 240 MHz to 400 MHz range of frequencies. The antenna is shown in Fig. 2.

2. Deck Box I/Deck Box II

The block diagram for deck box I and deck box II is shown in Fig. 3.

a. Deck Box I

A notch filter was provided at the input of deck box I to permit notching out of UHF radar signals. A transfer switch follows the notch filter to allow deck box II to be remotely switched "in" or "out" of the system. A bank of contiguous bandpass filters was provided to reduce the confusion caused by intermodulation products and images. The sole purpose for the limiter in the design was to protect the preamplifier at about a 20 dBm level. The limiter does not affect low or moderate level signals. The preamplifier was provided to decrease the overall system noise temperature.

To permit calibration and performance testing a calibrated noise diode, which can be remotely switched "in" or "out" was provided. The 10 dB attenuation pad was provided to allow the operator to determine whether an observed signal is being received by the test antenna, being picked up by the interconnecting cable between deck box I and the

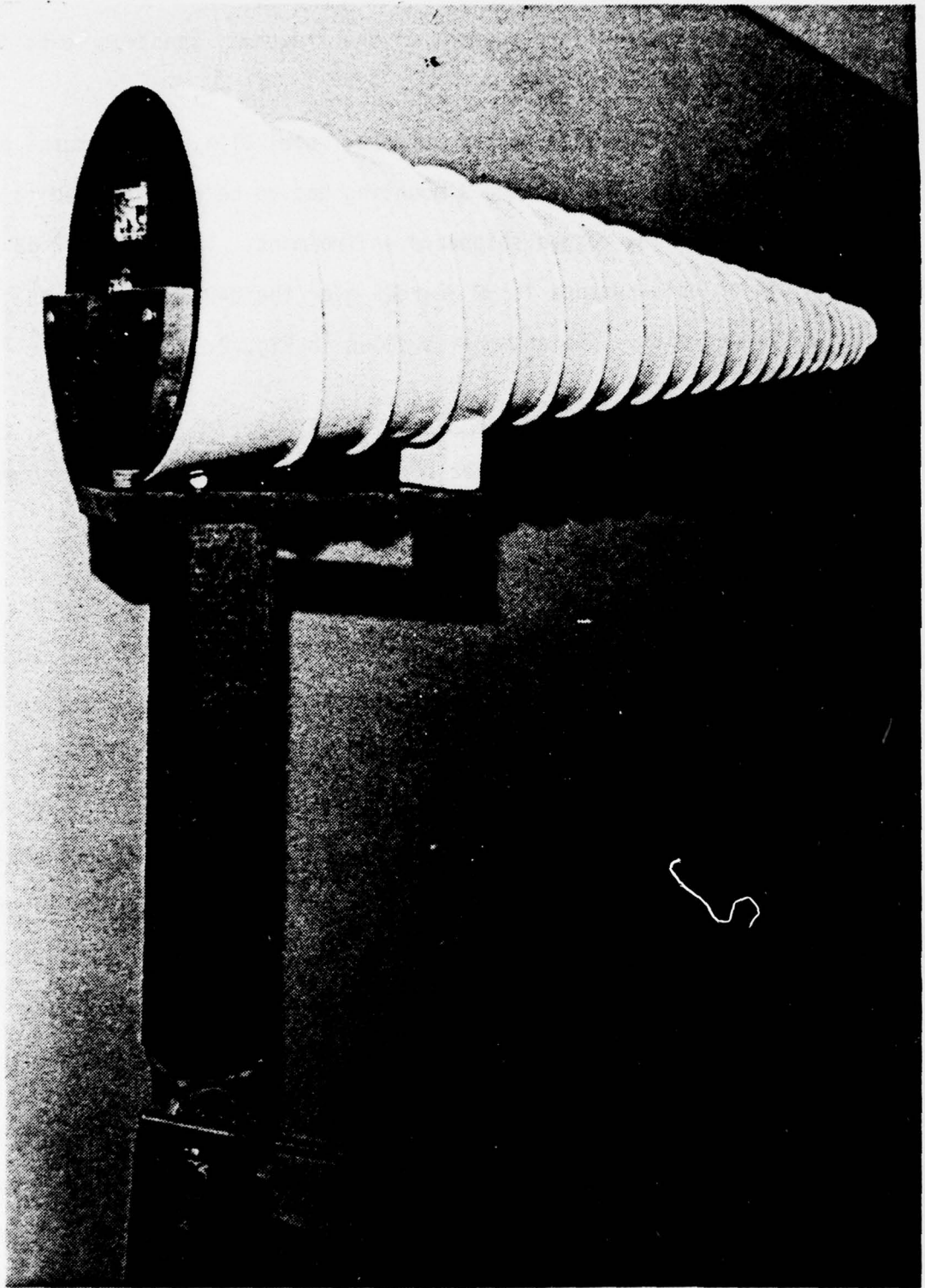

Figure 2. Test System Antenna

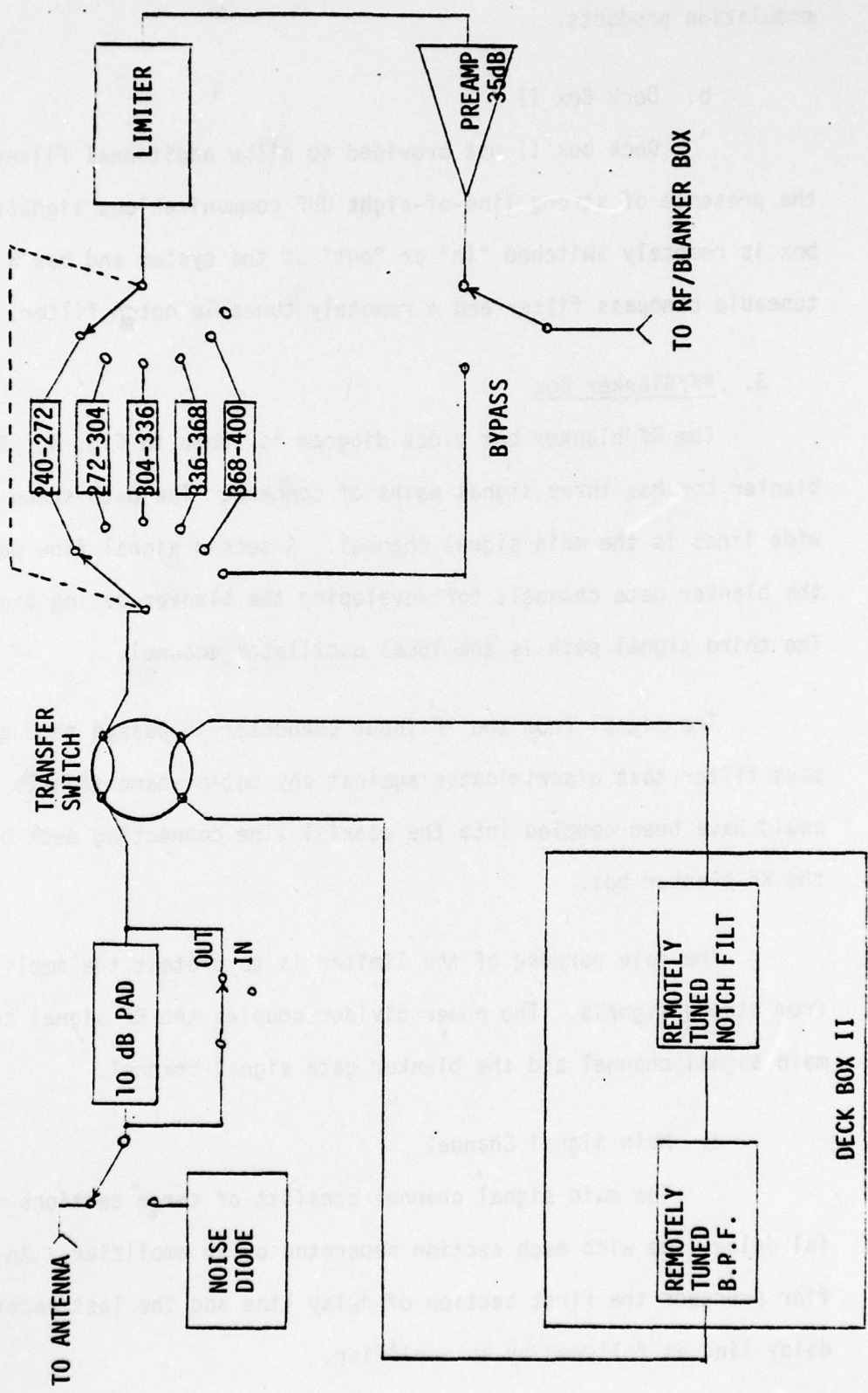

Figure 3. Deck Box I and Deck Box II

RF/blanker box, or being generated internally as the result of inter-modulation products.

b. Deck Box II

Deck box II was provided to allow additional filtering in the presence of strong line-of-sight UHF communications signals. This box is remotely switched "in" or "out" of the system and has a remotely tuneable bandpass filter and a remotely tuneable notch filter.

3. RF/Blanker Box

The RF/blanker box block diagram is shown in Fig. 4. The RF blanker box has three signal paths of concern. The path shown with the wide lines is the main signal channel. A second signal flow path is the blanker gate channel, for developing the blanker gating signal. The third signal path is the local oscillator channel.

The signal from the RF input connector is passed through a band-pass filter that discriminates against any out-of-band signals which could have been coupled into the coaxial line connecting deck box I to the RF/blanker box.

The sole purpose of the limiter is to protect the amplifiers from strong signals. The power divider couples the RF signal to the main signal channel and the blanker gate signal channel.

a. Main Signal Channel

The main signal channel consists of three sections of coaxial delay line with each section separated by an amplifier. An amplifier precedes the first section of delay line and the last section of delay line is followed by an amplifier.

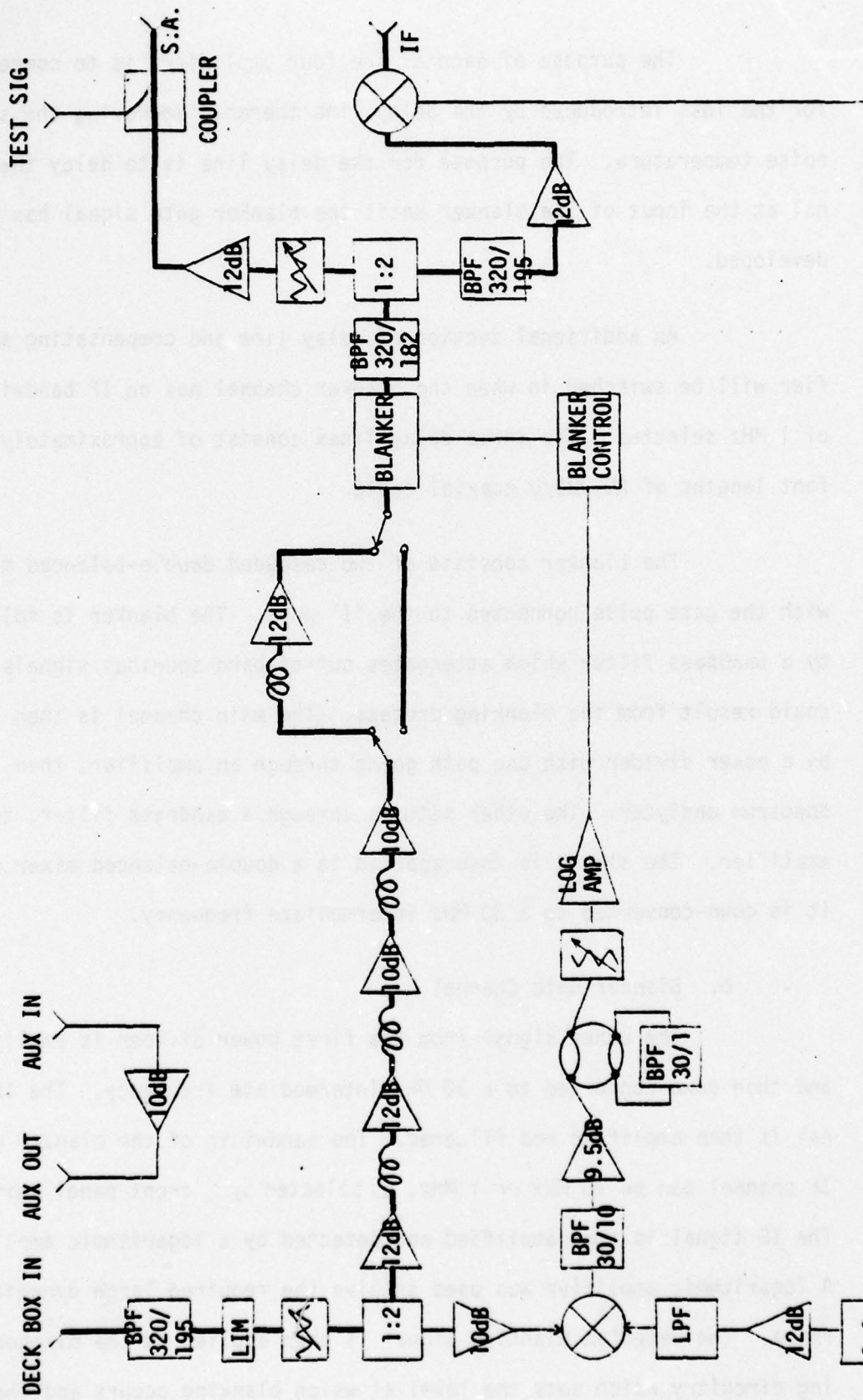

Figure 4. RF/Blanker Box Block Diagram

L.O. IN 9.0dBm

The purpose of each of the four amplifiers is to compensate for the loss introduced by the delay line thereby, improving the system noise temperature. The purpose for the delay line is to delay the signal at the input of the blanker until the blanker gate signal has been developed.

An additional section of delay line and compensating amplifier will be switched in when the blanker channel has an IF bandwidth of 1 MHz selected. The three delay lines consist of approximately 100 foot lengths of RG-223/U coaxial cable.

The blanker consists of two cascaded double-balanced mixers, with the gate pulse connected to the "I" port. The blanker is followed by a bandpass filter which attenuates out-of-band spurious signals which could result from the blanking process. The main channel is then split by a power divider with one path going through an amplifier, then to the spectrum analyzer. The other path is through a bandpass filter, to an amplifier. The signal is then applied to a double-balanced mixer where it is down-converted to a 30 MHz intermediate frequency.

b. Blanker Gate Channel

The other signal from the first power divider is amplified and then down-converted to a 30 MHz intermediate frequency. The IF signal is then amplified and filtered. The bandwidth of the blanker gate IF channel can be 10 MHz or 1 MHz, as selected by a front panel switch. The IF signal is then amplified and detected by a logarithmic amplifier. A logarithmic amplifier was used to give the required large dynamic range. The detected blanking signal is then applied to the blanker gating circuitry which sets the level at which blanking occurs and shapes the blanker gate pulse for applying to the blanker.

The local oscillator for both the main signal channel and the blanker gate channel is produced by the same source, a Wavetek 3000 signal generator. The local oscillator signal is split by a power divider with one output going through an amplifier which increases the signal to the required +17 dBm level and provides isolation between the two mixers. The signal is then passed through a lowpass filter which attenuates the spurious outputs from the signal generator which fall above the cutoff frequency of the filter. The signal is then applied to the "L" port of the main signal channel mixer. The other path from the power divider is identical to the path described above, with the exception that the output of the lowpass filter is applied to the blanker gate channel mixer.

4. IF Amplifier Box

The IF amplifier block diagram is shown in Fig. 5. The IF amplifier box contains an intermediate frequency amplifier operating at a center frequency of 30 MHz. The IF amplifier has both selectable gain and selectable bandwidth. The IF amplifier box also contains all D.C. power supplies for both the RF blanker box and the IF blanker box.

a. Inputs

Input to the IF amplifier box include 115 volts at 60 Hz for power requirements, 30 MHz IF input and local oscillator input at 29.9 MHz. An input also exists for coupling the vertical output of the spectrum analyzer to the level density analyzer.

b. Outputs

Outputs of the amplifier box include a detected video output which can be switched either to an oscilloscope or the level density

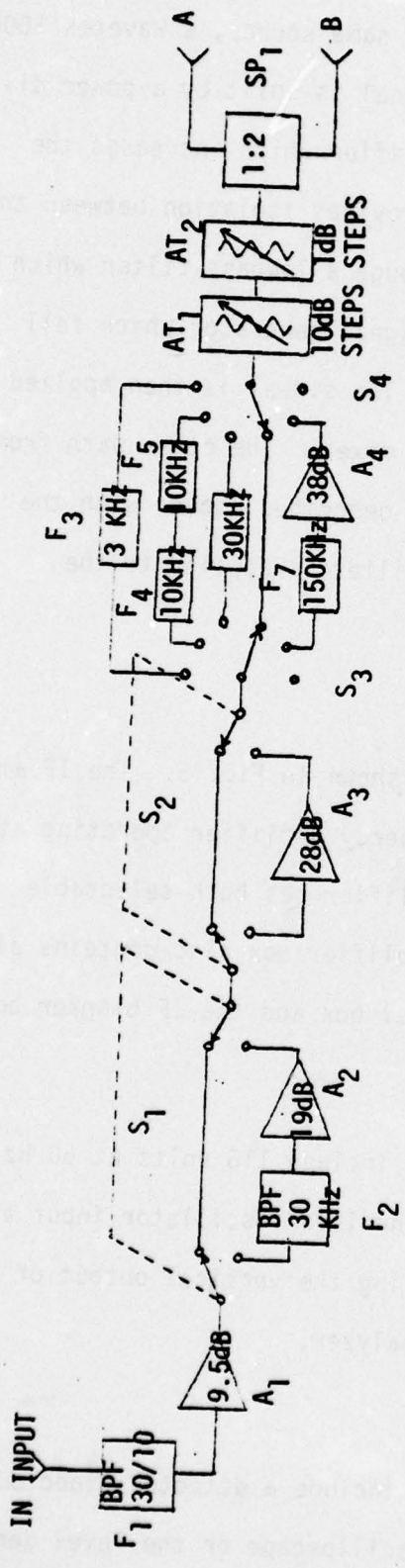

BANDPASS FILTERS

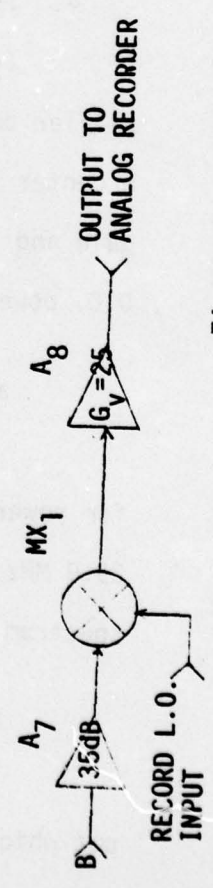
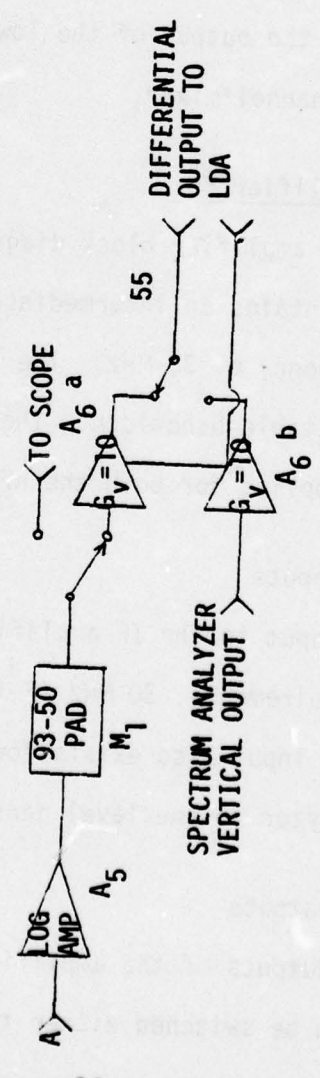

Figure 5. IF Amplifier Box Block Diagram

analyzer, a converted IF signal centered at 100 KHz to be used as an input to an analog tape recorder, and D.C. voltages for the RF blanker box. The video output level is between 0 and approximately 8 volts. The amplitude of the output for the analog tape recorder is approximately 3 volts peak. The D.C. voltages furnished to the RF blanker box are +28 volts, ± 15 volts, ± 12 volts, and +5 volts.

c. IF Signal Processing

The IF signal passes through a bandpass filter having a bandwidth of 10 MHz. The purpose of the filter is to insure any signals outside the bandpass which might have been produced in the mixing process or picked up by the coaxial cable connecting the RF blanker box to the IF amplifier box are attenuated. The signal level is then amplified by a 9.5 dB gain amplifier.

After this amplifier, two additional amplifiers may be individually switched "in" or "out" depending upon the mode of operation. If the first amplifier is switched in, 19 dB of additional gain is in the system. The first additional gain amplifier is preceded by a bandpass filter having a bandwidth of 30 KHz. This filter is to prevent saturation of the amplifier due to wideband noise. This amplifier will only be selected in the narrowband mode. The second additional gain amplifier has 28 dB gain. This amplifier can be switched "in" or "out" in any mode.

The signal is then passed through a filter or straight through as determined by the position of the filter select switches. In the record mode, a 150 KHz bandpass was required. Because of the

large insertion loss of the 150 KHz bandpass filter, an amplifier with a gain of 38 dB had to be included in that path.

After leaving the filter select switch, the signal passes through two step attenuators, which serve to give additional control over the system gain. The signal is then split by a power divider.

One path from the power divider is to the logarithmic amplifier. The output of the logarithmic amplifier is a detected video having a level between 0 and 2.5 volts, with 93 ohm output impedance. The 93 ohm output impedance had to be transformed to 50 ohms. This transformation was accomplished with a minimal loss pad. The output of the minimal loss pad was a level between 0 and 0.8 volts. This level was amplified by a voltage amplifier giving a level of between 0 and 8.0 volts for application to the level density analyzer.

The other path from the power divider is through a 35 dB gain amplifier to a high-level double-balanced mixer. The mixer has a local oscillator input of 29.9 MHz. The difference frequency which is centered about 100 KHz is selected by the voltage amplifier which has a high frequency cutoff of 1 MHz. This amplifier has a voltage gain of approximately 25. The output of the amplifier has a peak level of approximately 3 volts.

A signal from the vertical output of the spectrum analyzer can be accepted by the IF amplifier box. This signal which has a level of between 0 and -0.8 volts is amplified by an inverting voltage amplifier giving an output level of approximately 0 to 8 volts for application to the level density analyzer.

d. Modes of Operation

The IF amplifier can be configured to operate in one of three modes. These modes are narrowband, record, and wideband.

(1) Narrowband Mode

The narrowband mode is used for performing level density analysis. Bandwidths of 3 KHz, 10 KHz, and 30 KHz can be selected. The 19 dB additional gain amplifier must always be in for this mode. The maximum IF gain preceding the logarithmic amplifier is 48.8 dB in the narrowband mode.

(2) Record Mode

The record mode is used for recording on an analog tape recorder. The bandwidth in the record mode is 150 KHz. The information contained in the 150 KHz bandwidth centered at 30 MHz is down converted to provide a 150 KHz bandwidth centered at 100 KHz. This signal is then amplified by a voltage amplifier to provide a signal having a peak amplitude of approximately 3 volts for application to an analog tape recorder.

(3) Wideband Mode

The wideband mode is used for observing wide bandwidth signals, such as radar signals, on the oscilloscope. The bandwidth in the wideband mode is 10 MHz. The maximum IF gain preceding the logarithmic amplifier in this mode is 32 dB.

5. Level Density Analyzer

The level density analyzer samples the detected video signal from the IF amplifier and places counts in one of six counters corres-

ponding to the amount of time that the signal level was within a given window for that particular counter. This data can then be used to obtain a probability density function for the frequency being observed. The level density analyzer also has a counter to provide the number of times the blanker operated during the counting period. The time-of-day is also provided. All counters and the time-of-day are provided on a LED display, as well as being recorded on a digital recorder.

6. Spectrum Analyzer

The spectrum analyzer is an integral part of the system. The spectrum analyzer is used for displaying spectrum information which can be recorded on photographic film. The spectrum analyzer can also be used as a back-up for video information to the level density analyzer if the IF amplifier fails.

The spectrum analyzer used with this system is the Hewlett Packard HP 141T main frame with the 8554B RF plug-in and the 8552B IF plug-in.

7. Oscilloscope

The Tektronix 475 oscilloscope is an integral part of the test set. Its primary purpose is to view time domain information of wide-band signals at the scope output of the IF amplifier. The oscilloscope is also useful for trouble-shooting the system.

8. System Design Considerations

The design criteria established was to have a low-noise receiver capable of detecting low-level signals on the order of -130 dBm, while at the same time having the dynamic range to handle large signals without

being saturated. The test system had to have electromagnetic compatibility (EMC) with the shipboard environment. The availability of parts was also a major factor in the design considerations. The requirement existed that the system could be readily repaired in the field by the test system operators. The system was to be built with an internal system operational testing capability.

a. Noise Temperature Consideration

Low noise amplifiers which were in stock or readily available were used. The objective was to get as much gain in the early stages to reduce the overall noise temperature. Table 1 lists the components utilized in the system design and all pertinent data required in making the noise temperature calculations. Reference 4 gives the equivalent noise temperature (T_e) for a network of "N" elements as

$$T_e = T_1 + \frac{T_2}{G_1} + \frac{T_3}{G_1 G_2} + \dots + \frac{T_n}{G_1 G_2 \dots G_{n-1}}$$

where T_i is the noise temperature of the "ith" element and G_i is the gain of the "ith" element. The noise temperature for a passive element is given by $T = (L-1)T_a$, where L is the loss of the element and T_a is the temperature in degrees Kelvin. for these calculations T_a is assumed to be 290°K.

The amplifiers and passive element were arranged so that the overall gain preceding the passive element would reduce the noise temperature as seen by the input; however, not being so great that the amplifier immediately preceding the passive element would saturate. The desired goal is that the first amplifier to saturate be the last amplifier in the system.

<u>Component</u>	<u>Gain</u>	<u>Noise Figure</u>	<u>Noise Temp.</u>	<u>1dB Comp. Pt.</u>	<u>Remarks</u>
All Switches	-0.2dB	0.2dB	13.7°K	NA	
Notch Filter	-0.2dB	0.2dB	13.7°K	NA	CL 24-30
B.P.F. (256)	-1.09dB	1.09dB	82.7°K	NA	These filters all have 32 MHz bandpass and a center frequency of (XXX) MHz
B.P.F. (288)	-1.21dB	1.21dB	93.2°K	NA	
B.P.F. (320)	-1.29dB	1.29dB	100.3°K	NA	
B.P.F. (352)	-1.41dB	1.41dB	111.2°K	NA	
B.P.F. (388)	-1.53dB	1.53dB	122.5°K	NA	
Limiter	-0.5dB	0.5dB	35.4°K	NA	
Preamp	35dB	2.6dB	237.7°K	13dBm	Mfr. AEL MIC 3175 Optimax AH 4094
RF Amp	12dB	8.5dB	1763.0°K	20dBm	Avantek UAA 9662M
RF Amp	10dB	10.5dB	2963.9°K	20dBm	Watkins-Johnson 6200-303
RF Amp	28dB	3.0dB	288.6°K	20dBm	Watkins-Johnson 6200-352
IF Amp	9.5dB	5.5dB	739.0°K	15dBm	ANZAC AN102
IF Amp	19.0dB	5.5dB	739.0°K	15dBm	ANZAC AN105
IF Amp	28.0dB	5.5dB	739.0°K	15dBm	ANZAC AN108
IF Amp	38.0dB	3.0dB	288.6°K	19dBm	Watkins-Johnson 6200-363
IF Amp	35.0dB	2.6dB	237.7°K	13dBm	OPTIMAX AH 4094
Mixer	-8.5dB	9.0dB	1539.8°K	10dBm	Mini Circuits ZLW-1WH
Pwr. Divider	-3.5dB	3.5dB	359.2°K	NA	ANZAC T-1000
B.P.F.	-.55dB	.55dB	739.0°K	NA	TEXSCAN 88B320/195
B.P.F.	-.5dB	.5dB		NA	K & L

Table I. Element Gains and Noise Temperature

<u>Component</u>	<u>Gain</u>	<u>Noise Figure</u>	<u>Noise Temp.</u>	<u>1dB Comp. Pt.</u>	<u>Remarks</u>
Log IF Amp	28mv/dB	10dB	2610.0°K		RHG LLT 3010
IF B.P.F.	-2dB	2dB	169.6°K	NA	K & L 30 MHz cf 10 MHz BW
IF B.P.F.	-8.7dB	8.7dB	1859.8°K		McCoy 30 MHz cf 3 KHz BW
IF B.P.F.	-1.5dB	1.5dB	119.6°K		PIEZO 30 MHz cf 10 KHz BW
IF B.P.F.	-1.1dB	1.1dB	83.6°K		PIEZO 30 MHz cf 30 KHz BW
IF B.P.F.					K & L 30 MHz cf 150 KHz BW
IF B.P.F.	-3.0dB	3.0dB	288.6°K		30 MHz cf 1 MHz BW
Transfer Switch	-.2dB	.2dB	13.7°K		
IF Filter Switch	-.1dB	.1dB	6.8°K		
Directional Coupler					
Blankers	-8dB	-8dB	1539.8°K		(2) ZLM-IWH Mixers

Miscellaneous

Spectrum Analyzer Noise Figure 32.0dB Noise Temperature 457,088°K

<u>Coax Type</u>	<u>Loss Per 100 Feet</u>	
	200 MHz	300 MHz
RG 214	3.5dB	4.0dB
RF 223	6.7dB	8.0dB
		400 MHz
		5.0dB
		10.0dB

Table I. Element Gains and Noise Temperature (Cont.)

The noise temperature calculations are a function of frequency. The frequency dependence results from the frequency dependent loss introduced by the large amount of coaxial line utilized as delay line and for interconnection between deck box I and the RF/blanker box. A simplified block diagram for calculating the noise temperature is shown in Fig. 6. The losses of passive elements between amplifiers has been lumped into one block separating the two amplifiers. The noise temperature calculations are for worst case of 400 MHz and 200 feet of cable between the deck box I and the RF/blanker box. Noise temperature calculations for both 1 MHz and 10 MHz blanker bandwidths are provided. The IF bandwidth used was 3 KHz. The 28 dB additional IF gain is "out". The gain and noise temperature of each block are given in Table II. Table II gives the composition of each block of Fig. 6. Also given in this table is the necessary data for calculation of the noise temperature at 400 MHz. Table III gives the data required for calculation of the gain at 240 MHz. The noise temperature of the system is found by summing the contribution of each block as seen at the input.

The theoretical system noise temperature and noise figure for the IF channel and the spectrum analyzer channel and the spectrum analyzer channel for both 240 MHz and 400 MHz is given in Table IV.

It should be noted that the data listed in Table IV is as referenced to the input of deck box I and is calculated for the worst case of 200 feet of coaxial cable between deck box I and the RF/blanker box. The usual amount of cable will be between 50 and 100 feet. Also the 1 MHz blanker is rarely used.

b. Dynamic range considerations

To achieve the desired dynamic range, great care was taken to insure that the gains and losses were distributed in such a manner that the first stage to saturate would be near the end of the system. Attenuators were placed in both the RF/blanker box and the IF amplifier box to permit the operator to reduce the sensitivity in the presence of large signals which could drive the amplifiers into saturation. Both the 19 dB and 28 dB gain amplifiers can be switched in either individually or together depending upon the ambient RF environment. The main IF and the blanker IF channels have a logarithmic IF amplifier as the last stage. The logarithmic amplifiers have a dynamic range of greater than 80 dB.

c. Electromagnetic Compatibility (ECM)

To insure electromagnetic compatibility in the shipboard environment, good engineering practice as specified in Ref. 5 was followed. These practices include proper shielding, filtering of all power lines coming into the boxes, and proper grounding of each box of the system. The coaxial cable connecting deck box I to the RF/blanker box was RG-214/U which has a double braided shield. This reduces the possibility of pick-up by the cable.

d. System Reliability and Maintenance

To guarantee system reliability and provide for efficient maintenance capability, modular construction with commercially available components was utilized. An ample supply of spare parts was provided in a pack-up kit to permit repair at sea.

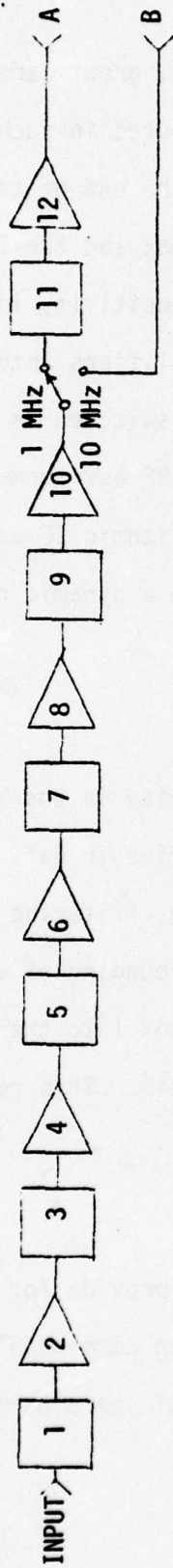

SEE TABLE II FOR
ELEMENT DESCRIPTION

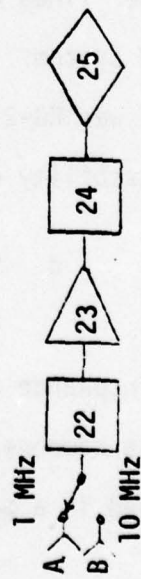

Figure 6. Simplified Block Diagram for Noise Calculations

<u>Block</u>	<u>G_i</u>	<u>T_i</u>	<u>G_c</u>	<u>T_c</u>	<u>Elements of Block</u>
1	-3.0dB	288.6°K	0.0dB	288.6°K	Notch Filter, BPF, 4 Switches & Limiter
2	35dB	237.7°K	-3.0dB	474.3°K	Preamplifier
3	-14.8dB	8467.9°K	32.0dB	5.3°K	200' RG214, SW, BPF and Limiter
4	12dB	1763.0°K	17.2dB	33.6°K	RF Amp #1
5	-10dB	2610.0°K	29.2dB	3.1°K	100' RG223
6	12dB	1763.0°K	19.2dB	21.2°K	RF Amp #2
7	-11.9dB	4201.6°K	31.2dB	3.2°K	110' RG223
8	10dB	2963.9°K	19.3dB	34.8°K	RF Amp #3
9	-10dB	2610.0°K	29.3dB	3.1°K	100' RG223
10	10dB	2963.9°K	19.3dB	34.8°K	RF Amp #4
11	-19.3dB	24,393°K	29.3dB	28.7°K	101' RG223, and 1 Switch
12	12dB	1763.0°K	10.0dB	176.3°K	RF Amp #5
13	-12.7dB	5110.1°K	22dB	32.2°K	Switch, Blanker, Splitter & 2 Band- pass Filters
14	12dB	1763.0°K	9.3dB	207.1°K	RF Amp #6
15	-8.5dB	1539.8°K	21.3dB	11.4°K	Mixer
16	-2.0dB	169.6°K	12.8dB	8.9°K	10 MHz Bandpass Filter
17	9.5dB	739.0°K	10.8dB	61.5°K	IF Amp #1
18	-1.2dB	92.3°K	20.3dB	0.9°K	Switch & 30 KHz Filter
19	19.0dB	739.0°K	19.1dB	9.1°K	IF Amp #2
20	-12.8dB	5235.8°K	38.1dB	0.8°K	Switches, 3 KHz, Filter & Splitter

Table II. Noise Temperature Data (400 MHz)

<u>Block</u>	<u>G_i</u>	<u>T_i</u>	<u>G_c</u>	<u>T_c</u>	<u>Elements of Block</u>
21	28 mv/dB	2610.0°K	25.3dB	7.7°K	Log IF Amp
22	-12.2dB	4522.8°K	22.0dB	28.5°K	Switch, Blanker and Splitter
23	28dB	288.6°K	9.8dB	30.2°K	RF Amp #6
24	-6.6dB	1035.6°K	37.8dB	0.2°K	Directional Coupler, Limiter & 6dB Pad
25	NA	457,088	31.2dB	346.7°K	Spectrum Analyzer

Block 13-31 @ 10 MHz BW $T_c = 66.2^\circ\text{K}$

Block 22-25 @ 10 MHz BW $T_c = 79.1^\circ\text{K}$

Notes:

1. G_i is total gain of block "i".
2. T_i is equivalent noise temperature of block "i".
3. G_c is cumulative gain of all block preceeding block "i".
4. T_c is contribution of block "i" to the system noise temperature as referenced to the input.
5. The data given in the table is for the blanker bandwidth of 1 MHz.
6. The noise temperature looking into the input to block 13 is 53,800°K, to reference this noise temperature to the system input for the 10 MHz blanker bandwidth case divide by the gain preceding block 13 when 10 MHz bandwidth is selected.
7. The noise temperature looking into the input to block 22 is 64290°K, to reference this to the system input for the 10 MHz blanker bandwidth case divide by the gain preceding block 22 when 10 MHz bandwidth is selected.

Table II. Noise Temperature Data (400 MHz) (Cont.)

<u>Block</u>	<u>G_i</u>	<u>T_i</u>	<u>G_c</u>	<u>T_c</u>
1	-2.59dB	236.5°K	0dB	236.5°K
2	35dB	237.7°K	-2.6dB	432.5°K
3	-8.7dB	1859.8°K	32.4dB	1.1°K
4	12dB	1763.0°K	23.7dB	7.5°K
5	-7.2dB	1231.0°K	35.7dB	0.3°K
6	12dB	1763.0°K	28.5dB	2.5°K
7	-8.6dB	4201.6°K	40.5dB	0.4°K
8	10dB	2963.9°K	31.9dB	1.9°K
9	-7.2dB	1231.9°K	41.9dB	0.1°K
10	10dB	2963.9°K	34.7dB	1.0°K
11	-13.8dB	6666.6°K	44.7dB	0.2°K
12	12dB	1763.0°K	30.9dB	1.4°K

Block 13-21 $T_c = 2.8^\circ\text{K} @ 1 \text{ MHz}; T_c = 1.8^\circ\text{K} @ 10 \text{ MHz}$

Block 22-25 $T_c = 3.3^\circ\text{K} @ 1 \text{ MHz}; T_c = 2.2^\circ\text{K} @ 10 \text{ MHz}$

Notes:

1. The noise temperature looking into the input to block 13 is 53,800°K regardless of frequency or blanker bandwidth to reference this to the system input divide by the cummutative gain prior to block 13.
2. The noise temperature looking into the input to block 22 is 64,290°K regardless of frequency or blanker bandwidth to reference this to the system input divide by the cummutative gain prior to block 22.
3. G_i , T_i , G_c and T_c are as in Table II.

Table III. Noise Temperature Data (240 MHz)

Frequency	240 MHz		400 MHz	
	1 MHz	10 MHz	1 MHz	10 MHz
Blanker BW	1 MHz	10 MHz	1 MHz	10 MHz
Spec. Anal. Noise Temp.	688.7°K	686.0°K	1512.6°K	981.1°K
IF Noise Temp.	688.2°K	685.6°K	1446.6°K	968.2°K
Spec. Anal. Noise Fig.	5.3dB	5.3dB	7.9dB	6.4dB
IF Noise Figure	5.3dB	5.3dB	7.8dB	6.4dB

Table IV. Calculated System Noise Temperature and Noise Figure

e. System Internal Testing Capability

To provide the capability to determine if the system is functioning properly, a calibrated noise generator was provided at the system input. This feature gives the ability to obtain the system noise figure in a minimum of time while requiring no additional test equipment. A 10 dB attenuation pad can be switched "in" or "out" at the input to enable the operator to determine if the signal being observed is a valid signal or an intermodulation product created within the system.

III. IF AMPLIFIER BOX CONSTRUCTION

The IF amplifier was constructed in a standard instrumentation cabinet made by Hewlett-Packard. An aluminum panel was positioned horizontally in the cabinet to facilitate the mounting of components. The front view of the IF amplifier box is shown in Fig. 7, while the rear view is shown in Fig. 8. The component layout for the top panel is shown in Fig. 9, while the component layout for the bottom panel is shown in Fig. 10. The parts list for the IF amplifier box is contained in Table V.

Modular construction was used throughout utilizing commercially available amplifier modules. This approach was used to facilitate maintenance in the field, as well as to provide for increased system reliability.

A. INTERCONNECTIONS

The RF interconnections between modules was accomplished with semi-rigid coaxial line, utilizing "SMA" fittings. Interconnections between modules and panel mounted "BNC" fittings were accomplished with RG-223/U coaxial cable.

The power lines were run using twisted pairs. The D. C. connections at all amplifiers were each fed through three ferrite beads and a 10 microfarad tantalum capacitor was installed from each of these terminals to ground. The additional filtering procedures were required to prevent oscillations resulting from power line feedback and large IF gain.

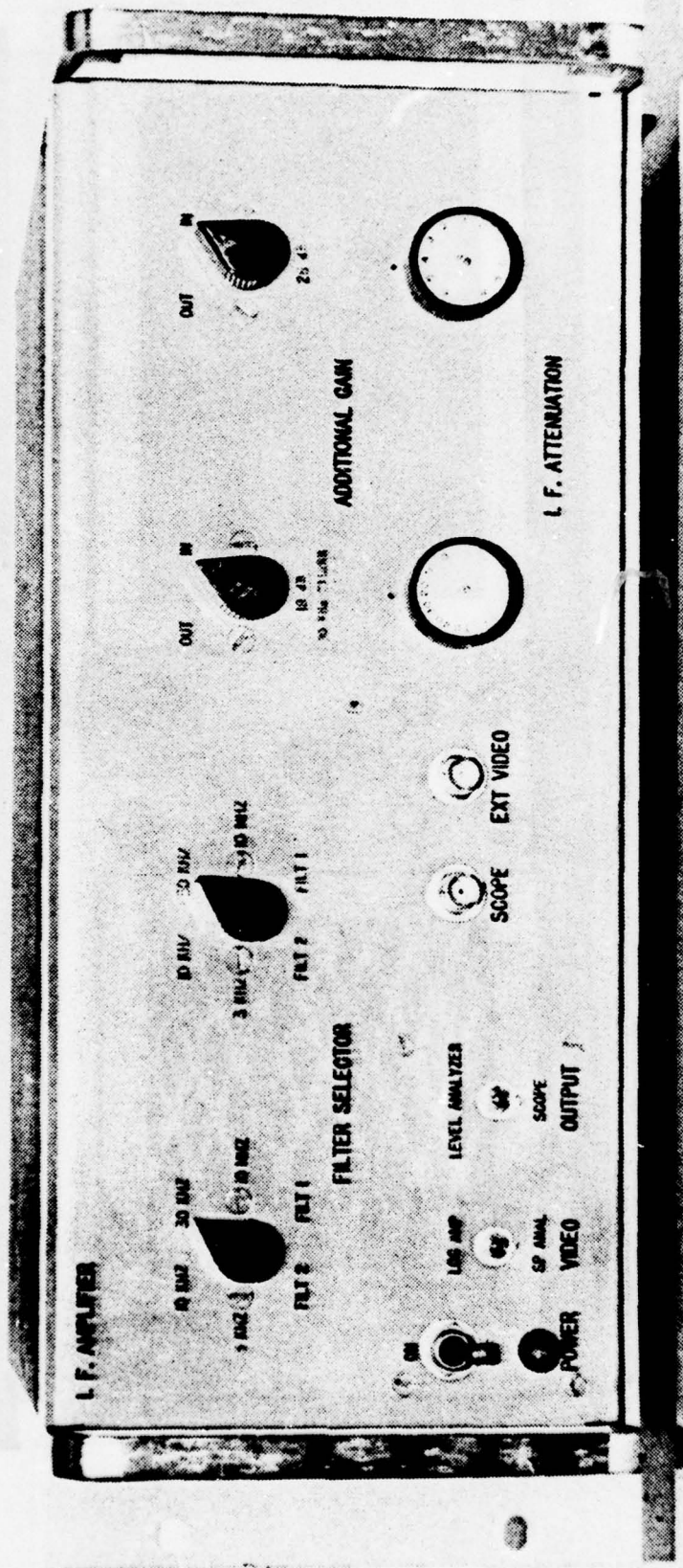

Figure 7. IF Amplifier Box (Front View)

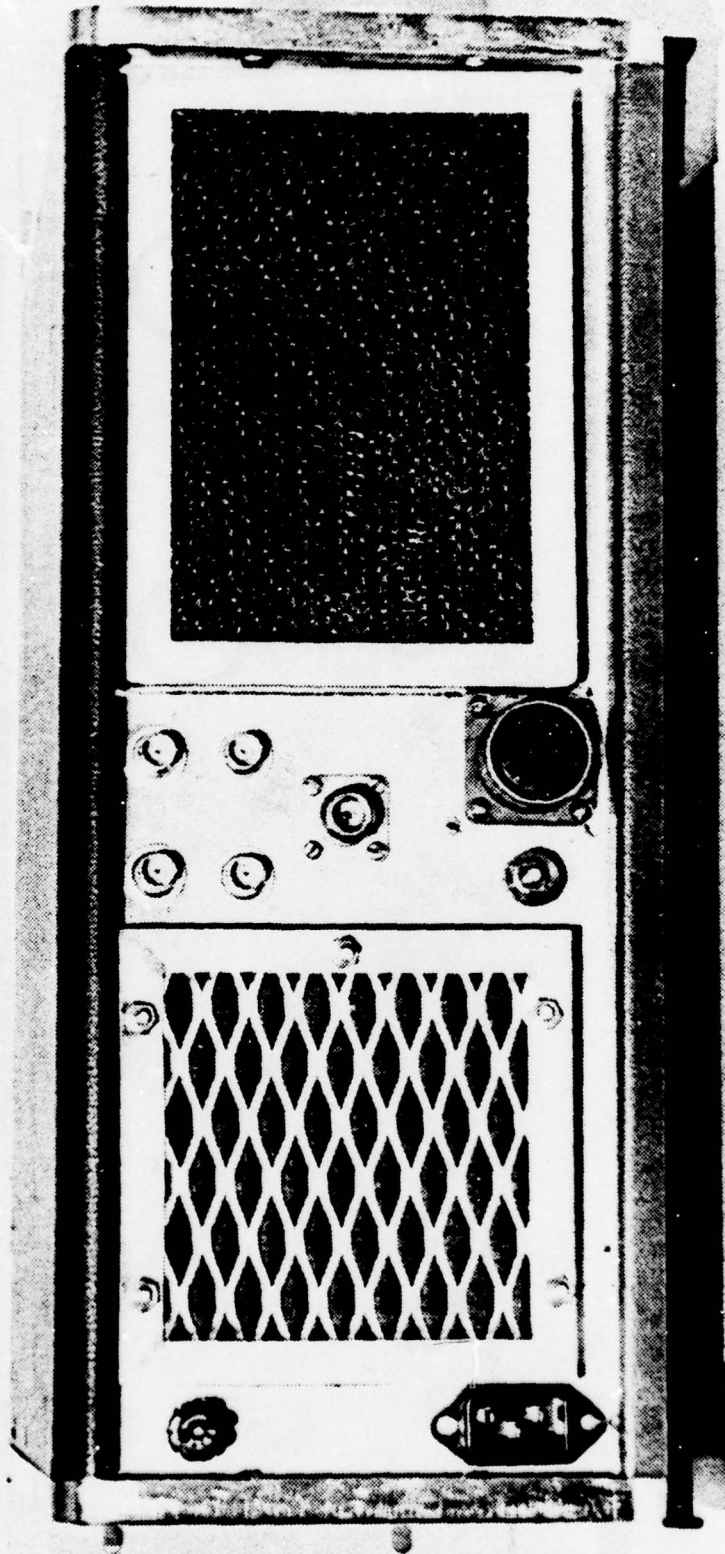

Figure 8. IF Amplifier Box (Rear View)

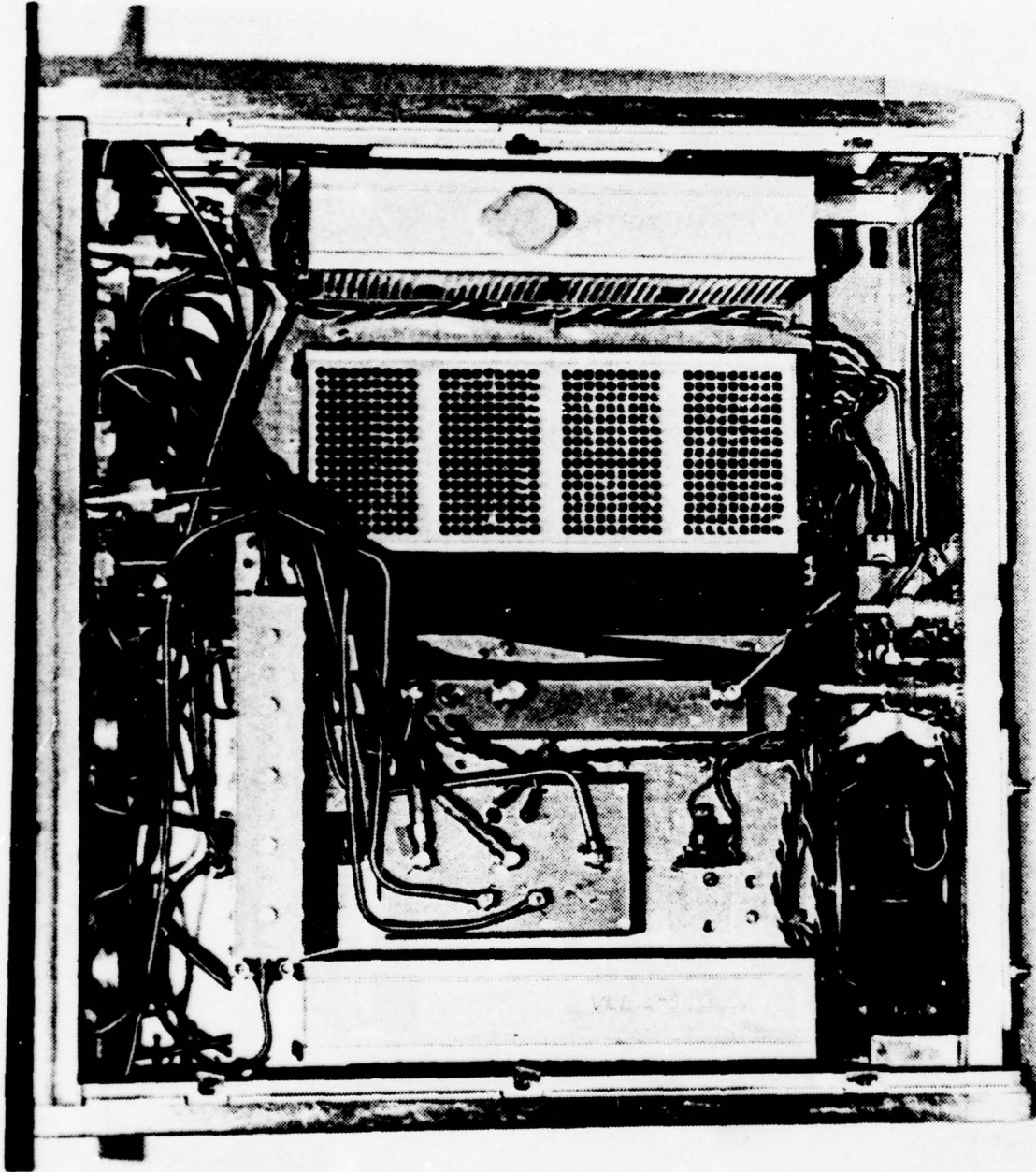

Figure 9. IF Amplifier Component Layout (Top View)

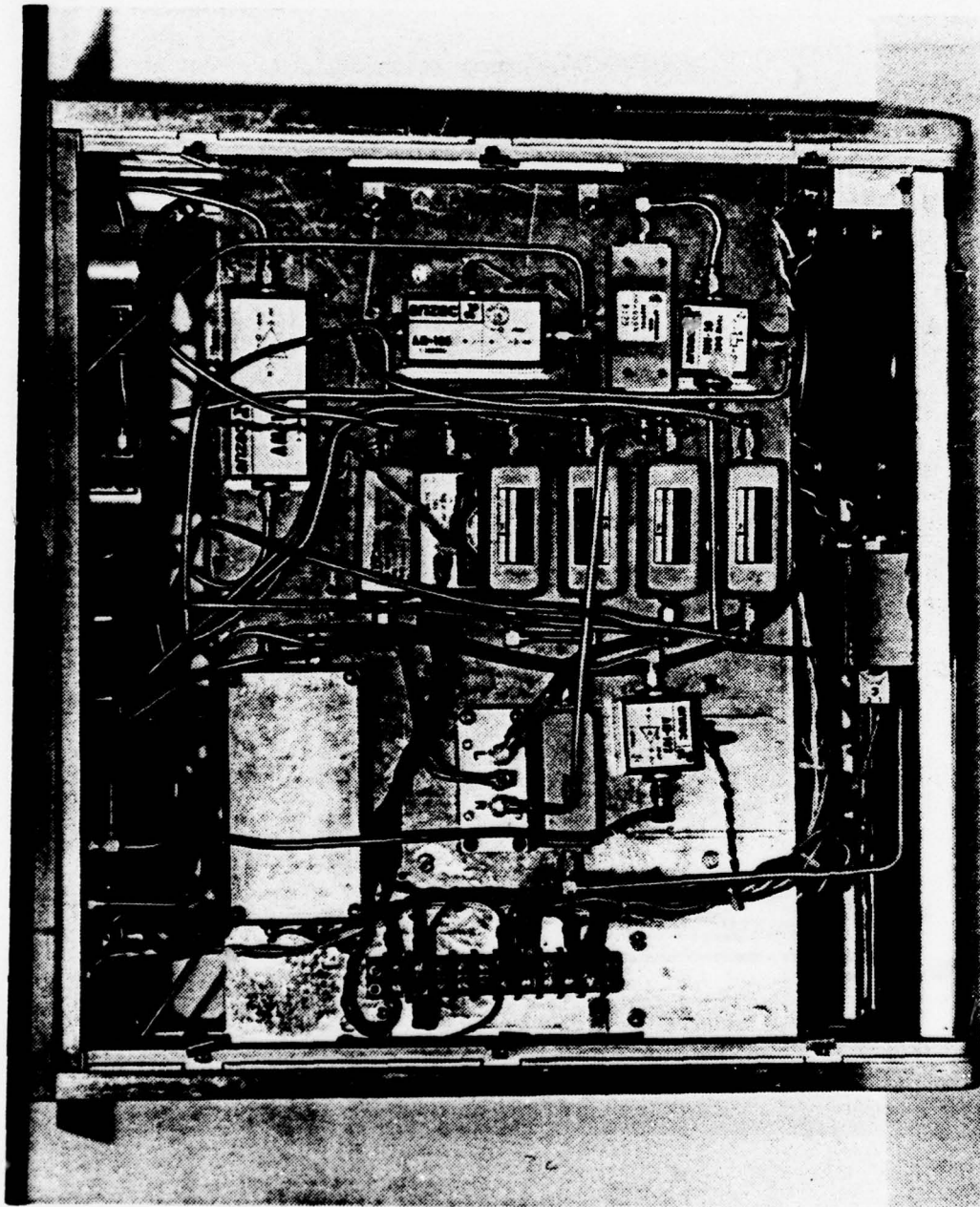

Figure 10. IF Amplifier Component Layout (Bottom View)

The video output from the voltage amplifier utilizes a differential line consisting of a pair of coaxial cables. The purpose for using a differential line was to reduce hum and noise pick-up on the interconnecting line between the IF amplifier box and the level density analyzer.

B. SWITCHES

All switches are located on the front panel. The additional gain amplifiers may be switched "in" or "out" of the system by coaxial switches S1 and S2. These switches are Texscan Model SW20, double-pole-double-throw units, with "TNC" type connectors.

The filters are selectable with coaxial switches S3 and S4. These switches are Texscan Model SW 66, one-pole-double-throw toggle switches. The "power" switch is a single-pole-single-throw toggle switch.

C. POWER SUPPLIES

Three D. C. power supplies are located on the top side of the panel. There is a ± 12 volt supply, ± 15 volt supply, and a +28 volt supply. All three supplies are manufactured by Acopian. Each supply was furnished with overvoltage protection. The +5 volts was obtained using a Fairchild $\mu A-7805$ voltage regulator which is fed from the +12 volts of the ± 12 volt supply.

D. LOGARITHMIC AMPLIFIER

The logarithmic amplifier is a model LLT 3010 manufactured by RHG Electronics. This unit has an output of 0 to 2.5 volts with an output impedance of 93 ohms. The logarithmic amplifier is mounted on the top side of the panel. Typical input vs. output characteristics of the logarithmic amplifier are shown in Fig. 11.

E. MINIMAL LOSS PAD

The interconnection between the IF amplifier box and the oscilloscope, as well as the interconnection between the IF amplifier box and the level density analyzer uses RG-223/U coaxial transmission line. The characteristic impedance of this line is 50 ohms, therefore, the 93 ohm output impedance of the logarithmic amplifier had to be transformed down to 50 ohms. To obtain this impedance match a minimal loss pad was constructed. The schematic for the minimal loss pad is shown in Fig. 12.

The values for the resistors R_1 and R_2 were determined by equations found in Ref. 6. The voltage at the output, V_2 , is given as $V_2 = 0.32V_1$, where V_1 is the voltage input of the pad. The output of the minimal loss pad will then be between 0 and 0.8 volts.

F. VIDEO AMPLIFIERS

The level density analyzer requires an input of between 0 and approximately 8 volts. To achieve this a voltage amplifier using an LM 318 operational amplifier was used in the noninverting mode. This amplifier is shown in Fig. 13.

The voltage gain of this noninverting amplifier is given by the equation $G = 1 + R_4/R_3$. To obtain the desired voltage gain of 10 with $R_4 = 10K\Omega$. R_3 was chosen to be $1.11K\Omega$. Capacitor C_1 was chosen experimentally to give a cutoff frequency of 30 KHz.

The spectrum analyzer vertical output level is between 0 and -0.8 volts, therefore an inverting voltage amplifier using an LM 318 operational amplifier was constructed having a voltage gain of -10. The schematic for this amplifier is shown in Fig. 14.

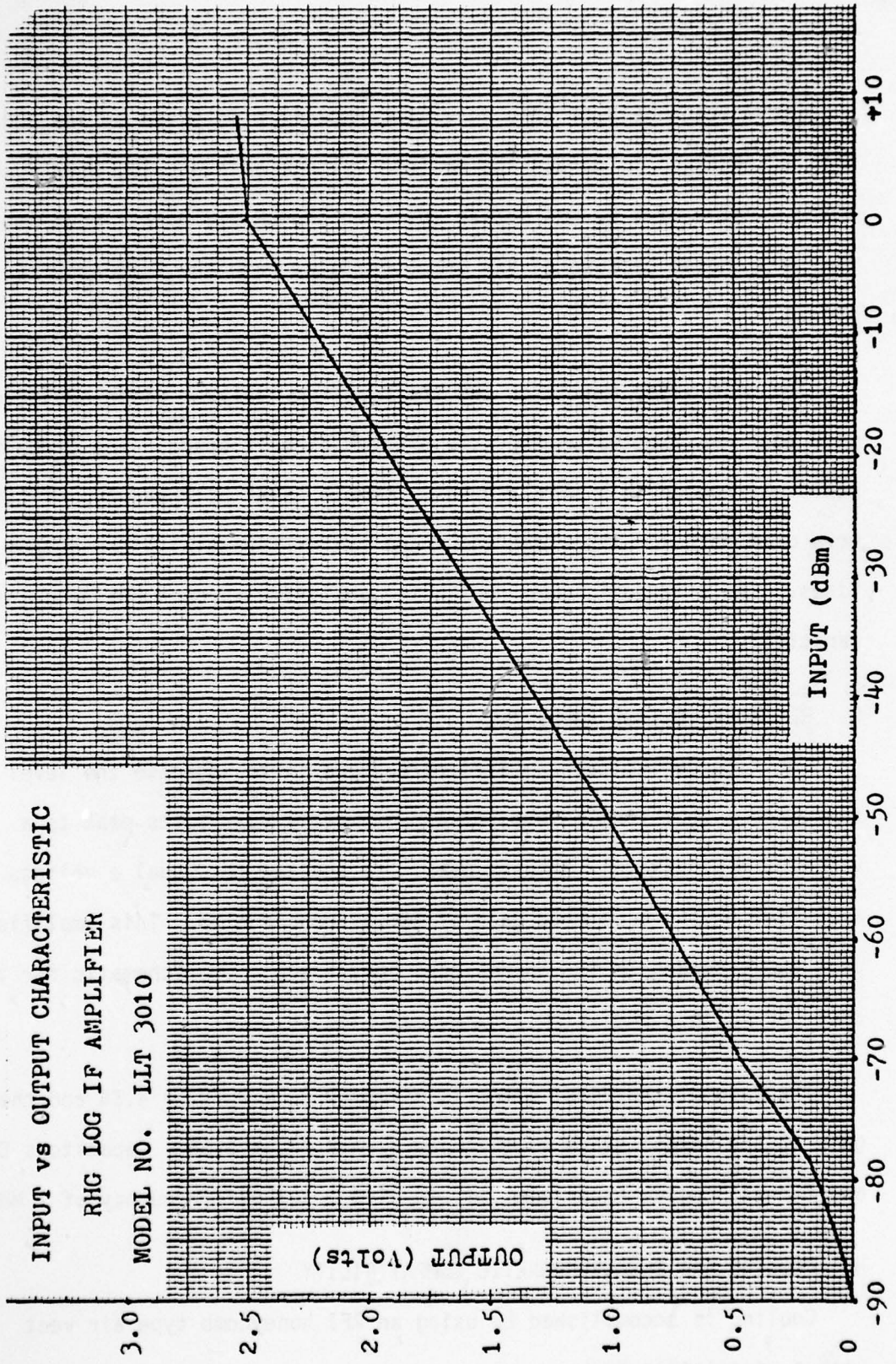

Figure 11.

The voltage gain of this inverting amplifier is given by the equation $G = R_7/R_5$. To obtain the desired voltage gain of -10, with $R_7 = 10K\Omega$, a value of $1 K\Omega$ was chosen for R_5 . The LM 318 operational amplifier was chosen because of its excellent slew rate and frequency response.

The main video amplifier and the spectrum analyzer video amplifier were both constructed on the same printed circuit board. The circuit board was housed in a shielded box. Female "SMA" bulkhead type fittings were used both for the video input and the differential video output lines. The ± 12 volts were fed to the amplifier through RFI feed-thru capacitors.

G. RECORDER VOLTAGE AMPLIFIER

The recorder voltage amplifiers purpose is to increase the level of the mixer output from a level of approximately 0.12 volts peak to a value of approximately 3 volts peak. To achieve this goal a voltage amplifier having a voltage gain of 25 was constructed. This amplifier uses two cascaded LM 318 operational amplifiers. The schematic for the recorder voltage amplifier is shown in Fig. 15.

The gain of the first stage is given by $G_v = R_2/R_1 = 4.54$ and the gain of the second stage is given by $G_v = R_4/R_3 = 5.55$. Capacitors C_1 and C_2 were chosen experimentally to give a cut-off frequency of 1 MHz.

H. COOLING AND ELECTROMAGNETIC COMPATIBILITY

Cooling is accomplished by using an RFI honeycomb type air vent with a ventilating fan.

To provide maximum electromagnetic compatibility, a commercially available RFI line filter was used. Another measure to provide good electromagnetic compatibility, was the construction of shielded enclosures around any element without RFI protection which has a shaft protruding through an outside panel. The enclosures all have RFI gasket material between the enclosure and the panel. All D. C. lines from the enclosure are through RFI feed-through capacitors and RF or video lines or through "SMA" bulkhead connectors.

<u>Item</u>	<u>Nomenclature</u>	<u>Manufacturer & Parts Number</u>
<u>Amplifiers</u>		
A1	9.5 dB gain amplifier	Anzac AM 102
A2	19.0 dB gain amplifier	Anzac AM 105
A3	28.0 dB gain amplifier	Anzac AM 108
A4	35.0 dB gain amplifier	Watkin Johnson WJ 6200-363
A5	Logarithmic amplifier	RHG LLT 3010
A6	Video amplifiers	See separate listing
A7	35.0 dB gain amplifier	Optimax AH 4094
A8	Recorder amplifier	See separate listing
<u>Filters</u>		
F1	30 MHz bandpass filter, 10 MHz bandwidth	K & L, 6B50-30/10
F2, F6	30 MHz bandpass filter, 30 KHz bandwidth	Piezo, 5152
F3	30 MHz bandpass filter, 3 KHz bandwidth	McCoy, 111B141
F4, F5	30 MHz bandpass filter, 10 KHz bandwidth	Piezo, 5151
F7	30 MHz bandpass filter, 150 KHz bandwidth	K & L, 5020-30/0.15-0
<u>Attenuators</u>		
AT1	Step attenuator 0-100 dB	Telonic 8120S
AT2	Step attenuator 0-10 dB	Telonic 8122S
<u>Switches</u>		
S1, S2	2 pole coaxial rotary switch	Texscan SW20
S3, S4	6 pole coaxial rotary switch	Texscan SW66
S5	Miniature S.P.D.T. toggle Switch	

Table V. IF Amplifier Box Parts List

<u>Item</u>	<u>Nomenclature</u>	<u>Manufacturer & Parts Number</u>
<u>Miscellaneous</u>		
PF1	Power line RFI filter	Corcom 15F2457
MX1	Mixer	Mini Circuits
SP1	Power divider	Anzac THV-50
FN1	Cooling fan	IMC Magnetics Corp. PS2107F.O.I.
<u>Power Supplies</u>		
PS1	+28V. @ 1A power supply	Acopian VA28NT80
PS2	±15V. @ 500ma power supply	Acopian VLD 15-50
PS3	±12V. @ 1A power supply	Acopian VLD 12-100
<u>Video Amplifier Assembly (A6)</u>		
A6R1	100Ω, 1/2 w. resistor	
A6R2	1 KΩ, 1/2 w. resistor	
A6R3	1.11KΩ, 1/2 w. resistor	
A6R4	10 KΩ, 1/2 w. resistor	
A6R5	1 KΩ, 1/4 w. resistor	
A6R6	1 KΩ, 1/4 w. resistor	
A6R7	10 KΩ, 1/4 w. resistor	
A6C1	150 pf, ceramic capacitor	
A6C2	0.10 μf, ceramic capacitor	
A6C3	0.10 μf, ceramic capacitor	
A6C4	150 pf, ceramic capacitor	
A6C5	0.10 μf, ceramic capacitor	
A6C6	0.10 μf, ceramic capacitor	
Q1, Q2	LM 318 operational amplifier	

Table V. IF Amplifier Box Parts List (Cont.)

<u>Item</u>	<u>Nomenclature</u>	<u>Manufacturer & Parts Number</u>
<u>Recorder Voltage Amplifier (A8)</u>		
A8R1	2.2K Ω , 1/4 w. resistor	
A8R2	10K Ω , 1/4 w. resistor	
A8R3	2.2K Ω , 1/4 w. resistor	
A8R4	1.8K Ω , 1/4 w. resistor	
A8R5	10K Ω , 1/4 w. resistor	
A8R6	1.8K Ω , 1/4 w. resistor	
A8C1	5 pf, ceramic capacitor	
A8C2	5 pf, ceramic capacitor	
A8C3	0.10 μ f, ceramic capacitor	
A8C4	0.10 μ f, ceramic capacitor	
Q1, Q2	LM 318, operational amplifier	
<u>Minimal Loss Pad</u>		
R1	63.2 Ω , 1/4 w. resistor	
R2	73.5 Ω , 1/4 w. resistor	

Table V. IF Amplifier Box Parts List (Cont.)

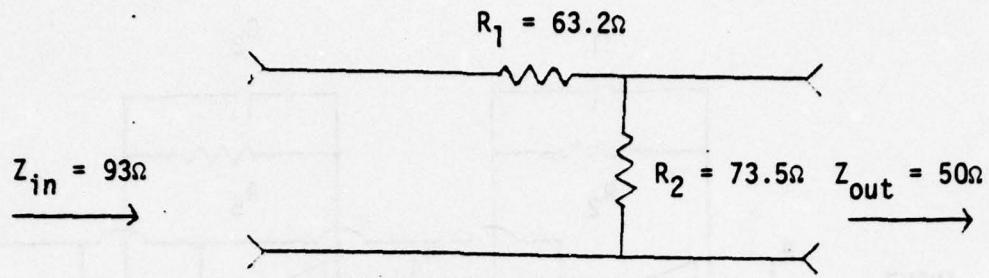

Figure 12. Minimal Loss Pad

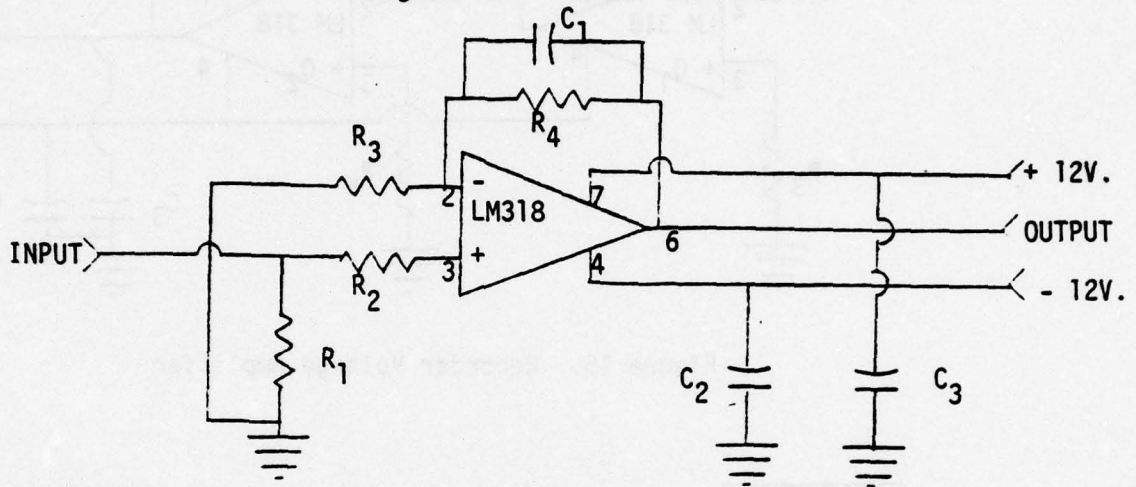

Figure 13. Main Video Amplifier A6 a

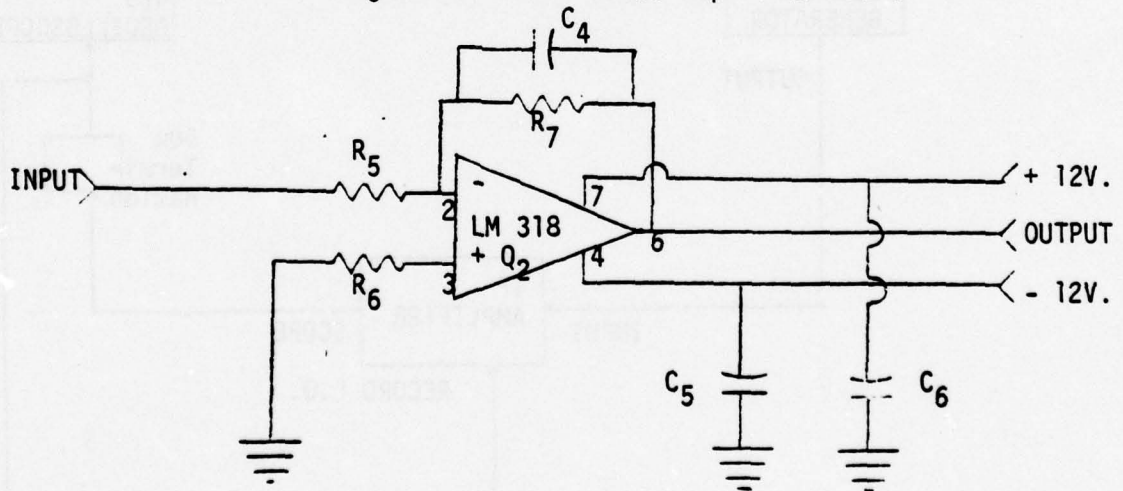

Figure 14. Spectrum Analyzer Video Amplifier A6 b

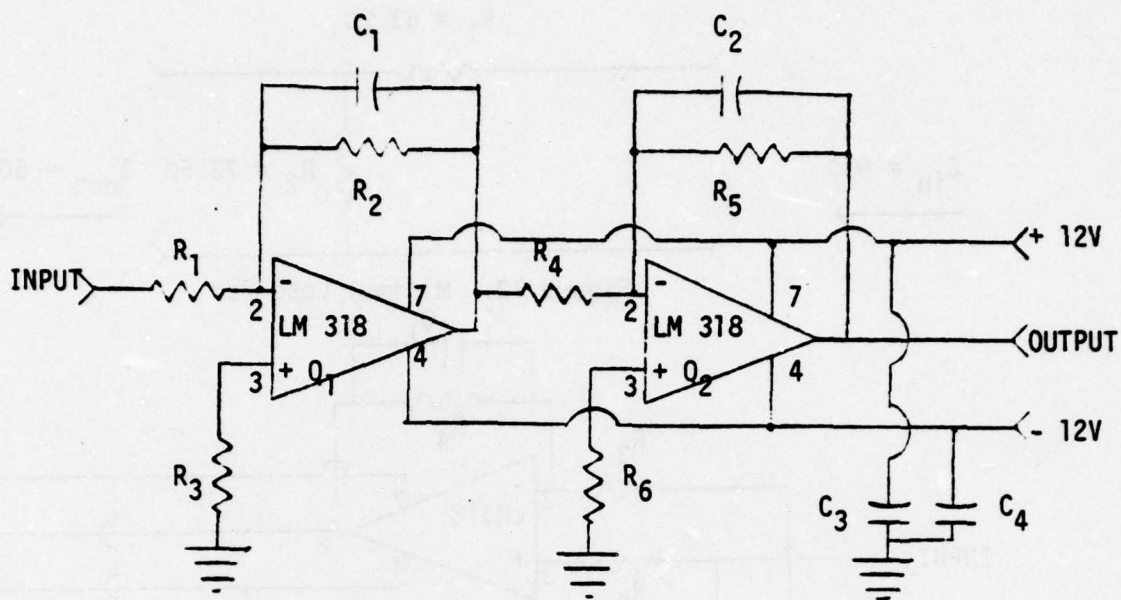

Figure 15. Recorder Voltage Amplifier

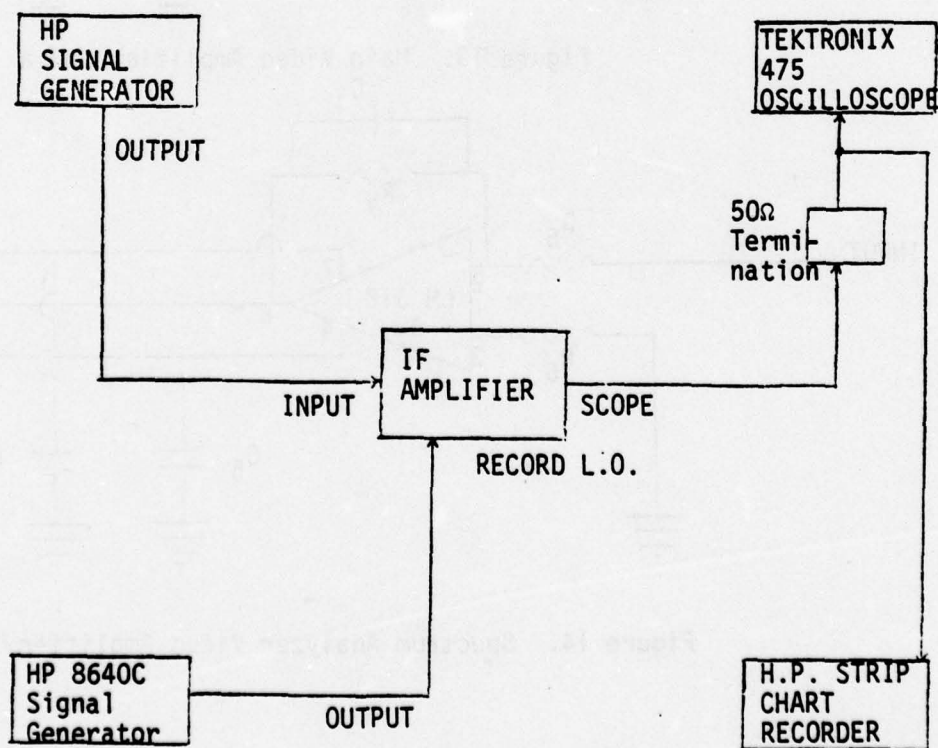

Figure 16. Equipment Configuration for IF Testing

IV. IF AMPLIFIER TESTING

The IF amplifier testing phase of the project was to verify that the IF amplifier was functioning as it was designed to function and to establish some "bench-mark" quantities for future reference to verify on a daily basis that the equipment is continuing to function as it was designed to function.

The equipment configuration for testing the IF amplifier is shown in Fig. 16. The initial control settings were as in Table VI.

A. LOGARITHMIC AMPLIFIER CALIBRATION

With the equipment configured as in Fig. 16 and controls set as in Table IV, one of the IF attenuators was set to a blank position. The "DC offset" control on the logarithmic amplifier was adjusted to give a zero volt average on the strip-chart recorder. The IF attenuators were then both set to 0 dB.

B. OUTPUT VS. INPUT CHARACTERISTICS

The purposes for this series of tests were to determine the gain and the 1 dB compression point.

1. Strip-Chart Recorder Calibration

The equipment was configured as in Fig. 16, and the controls were set as in Table VI. The signal generator was set up to provide a -3.8 dBm "CW" signal. The "sensitivity" of the strip-chart recorder was set to 50 milli-volts per division and the "amplitude adjust" was set to give eight major divisions of deflection. The IF attenuators were then set to give 60 dB of attenuation and the "zero adjust" of

<u>Control</u>	<u>Setting</u>
Power	On
Filters (both)	10 MHz
19 dB additional gain	Out
28 dB additional gain	Out
Attenuation (both)	0 dB
Video	Log Amp
Output	Level Analyzer

Table VI. Initial Control Settings for IF Amplifier Testing

the strip-chart recorder was set to give two major divisions of deflection. The IF attenuators were then set to give 20 dB of attenuation and the "amplitude adjust" of the strip-chart recorder was set to give six major divisions of deflection. The above two steps were repeated until the "amplitude" or "zero adjust" no longer required adjustment after changing the attenuation setting.

2. Linearity Check

The purpose of this test was to determine that the output of the logarithmic amplifier was a linear change when the input changed logarithmically over the entire dynamic range of the logarithmic amplifier.

The signal generator output was set at -3.8 dBm. The IF attenuator was set to give 80 dB of attenuation. The strip-chart recorder was allowed to run at 6 cm per minute. The attenuation was decreased at ten second intervals until the IF attenuation was 0 dB. A copy of the strip-chart obtained is shown in Fig. 17.

3. One dB Compression Point Check

The output of the signal generator initially set at -3.8 dBm was stepped down by 10 dB while the vernier was increased by 1 dB. The output was then stepped up by 10 dB, while the strip-chart recorder was observed to give a one major division change. The procedure was repeated until the strip-chart recorder gave only a 0.9 major division change. The signal generator output at that time was the 1 dB compression point of the IF amplifier. The 1 dB compression point was found to be -3.0 dBm in this configuration. The 1 dB compression point with

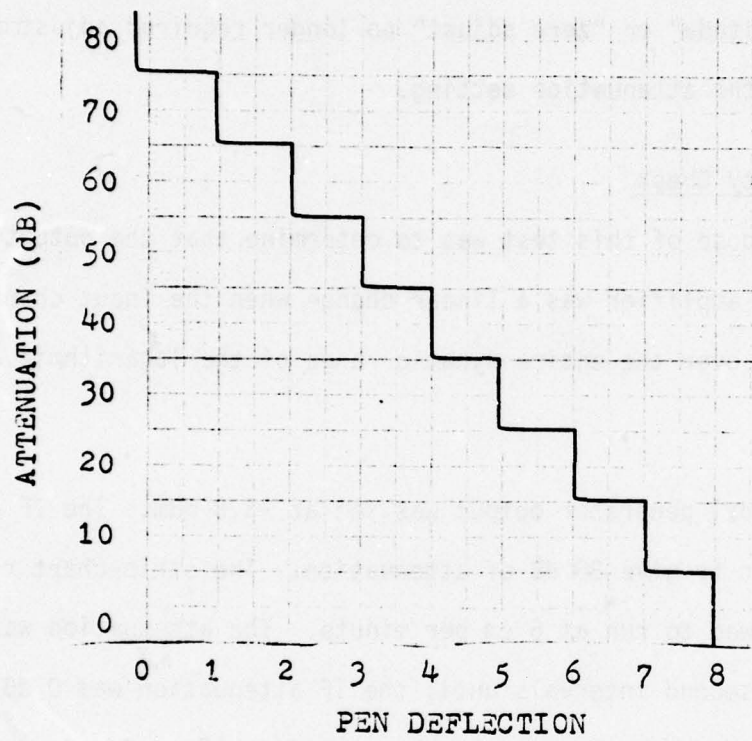

Figure 17. IF Amplifier Response to 10 dB Steps in Input Level

the additional gain amplifiers "in" were found in a similar manner. The 1 dB compression point for only the 19 dB additional gain amplifier "in" was -21 dBm. The 1 dB compression point for only the 28 dB additional gain amplifiers in was -31 dBm. The 1 dB compression point for both additional amplifiers in was -48 dBm.

4. Additional Gain Amplifiers Check

To check the 28 dB additional gain amplifier with both additional gains switched "out" the signal generator output level was decreased until the strip-chart recorder gave a deflection of five major divisions. The signal generator output level recorded was -33.8 dBm. The 28 dB gain amplifier was switched "in" and the signal generator output level was again decreased to give five major divisions. The signal generator output level recorded was -61.5 dBm. The difference between the two signal generator output levels is the actual gain of the amplifier which was 27.7 dB.

The actual gain of the 19 dB additional gain amplifier was found in the same manner as above to be 17.4 dB. The relative large difference from the 19 dB is accounted for by the insertion loss of the 30 KHz filter in that path.

The gain with both additional amplifiers "in" was found in the same manner to be 45 dB.

5. Selectable Filter Checks

To determine the insertion loss of the selectable filters, the signal generator output level was adjusted to -33.8 dBm to give five major divisions of deflection on the strip-chart recorder, when both

additional amplifiers are "out" and the filter selector switches both in the "10 MHz" position. The filter selector switches were then both switched to the "3 KHz" position and the signal generator output level was increased until the strip-chart recorder deflection was again five major divisions. The signal generator level was recorded as -25.8 dBm. The change of 8 dB is the insertion loss for the 3 KHz bandpass filter.

The insertion loss for the other selectable filters was found in the same manner. The total insertion loss for the two cascaded 10 KHz bandpass filters was found to be 4.2 dB. The insertion loss for the 30 KHz bandpass filter was found to be 1.7 dB.

6. Analog Recorder Channel Checks

The HP 8640B signal generator is used to provide a 29.9 MHz local oscillator signal at 17 dBm. With the 28 dB additional gain amplifier switched "in" and the selectable filters switches in the "Flit 1" position, the oscilloscope was connected to the recorder output jack of the IF amplifier. With a -80 dBm level CW signal at 30.0 MHz inserted at the IF input, the oscilloscope displayed a 100 KHz sine wave having a peak value of 6.8 volts.

The HP 8660C signal generator at the IF input was then placed in the sweep mode with the horizontal trace of the oscilloscope being swept by the signal generator. The frequency response is shown in Fig. 18. The center of the horizontal trace corresponds to 30 MHz, at the input. The trace represents a sweep width of 250 KHz. The presentation is a linear display of the tape output as the signal generator is swept.

7. Frequency Response

The frequency response of the IF amplifier including the log amplifier was obtained by sweeping the HP 8660C signal generator, while at the same time sweeping the horizontal trace of the Tektronix 475 oscilloscope. The frequency response for each of the IF bandwidths is shown in Fig. 19 through Fig. 22. The IF bandwidth and the scanwidth is given with each picture. The vertical deflection was adjusted to give a presentation corresponding to 10 dB per major division.

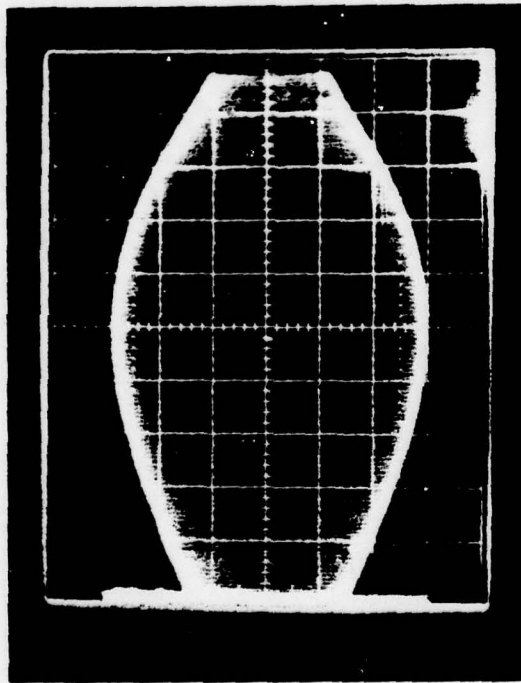

Figure 18. IF Tape Channel Frequency Response. The Center Frequency is 30 MHz, the Sweepwidth is 250 KHz, and the display is linear.

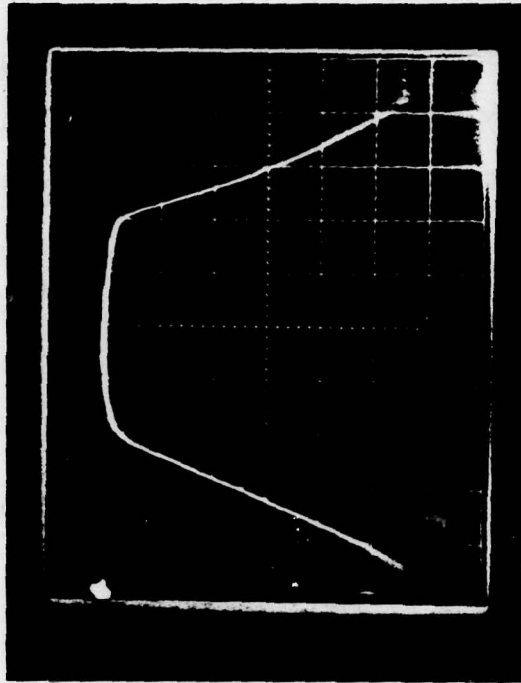

Figure 19. IF Frequency Response for 10 MHz IF Bandwidth. The Center Frequency is 30 MHz, the Sweepwidth is 25 MHz, and the Display is Set Up to Give One Major Division of Deflection for a 10 dB Change in Signal Level.

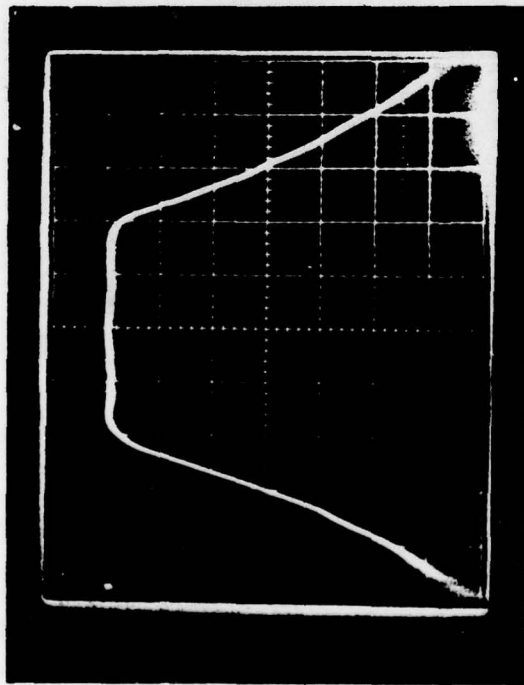

Figure 20. IF Frequency Response for 30 KHz IF Bandwidth. The center frequency is 30 MHz, the sweepwidth is 75 KHz, and the display is set up to give one major division of deflection for 10 dB change in signal level.

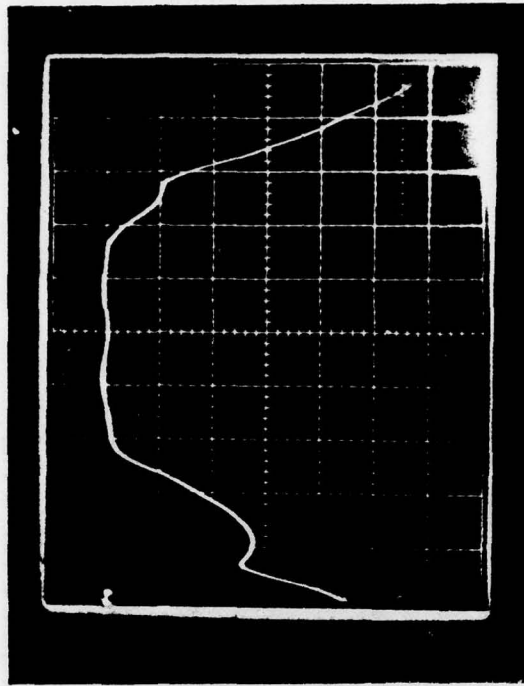

Figure 21. IF Frequency Response for 10 KHz IF Bandwidth. The center frequency is 30 MHz, the sweepwidth is 25 KHz, and the display is set up to give one major division of deflection for a 10 dB change in signal level.

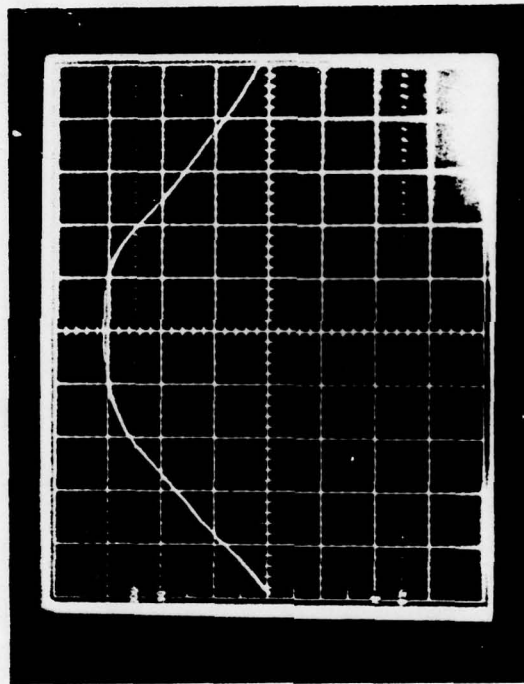

Figure 22. IF Frequency Response for 3 KHz IF Bandwidth. The center frequency is 30 MHz, the sweepwidth is 7.5 KHz, and the display is set up to give one major division of deflection for a 10 dB change in signal level.

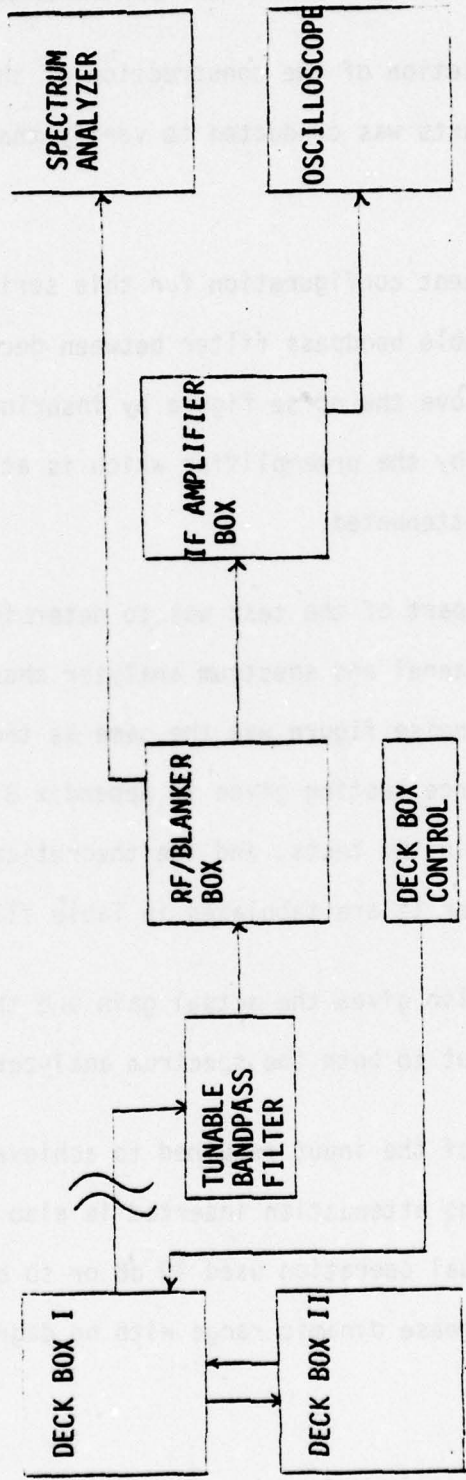

Figure 23. Equipment Configuration for System Testing

V. ACTUAL PERFORMANCE

Upon completion of the construction of the shipboard RFI test set, a series of tests was conducted to verify that the system was functioning properly.

The equipment configuration for this series of tests is as in Fig. 23. The tuneable bandpass filter between deck box I and the RF/blanker box is to improve the noise figure by insuring that that portion of the noise created by the preamplifier which is at the image frequency of the mixer is attenuated.

The first part of the test was to determine the noise figure for both the IF channel and spectrum analyzer channel. The procedure used to obtain the noise figure was the same as the procedure used in the daily performance testing given in Appendix B. The actual noise figure, as determined in the tests, and the theoretical noise figure, as calculated in chapter II are tabulated in Table VII.

Table VI also gives the actual gain and theoretical gain from the deck box I input to both the spectrum analyzer and to the IF amplifier.

The level of the input required to achieve 1 dB compression for both channels with no attenuation inserted is also given in this table. Although low, usual operation used 20 dB or so of attenuation in the RF/blanker to increase dynamic range with no degradation of noise figure.

Frequency	240 MHz		400 MHz	
	1 MHz	10 MHz	1 MHz	10 MHz
Blanker Bandwidth				
Theoretical IF Noise Fig.	5.3 dB	5.3 dB	7.8 dB	6.4 dB
Actual IF Noise Fig.	4.7 dB	4.7 dB	6.9 dB	6.9 dB
Theoretical SP. Anal. Noise Fig.	5.3 dB	5.3 dB	7.9 dB	7.9 dB
Actual SP. Anal. Noise Fig.	4.7 dB	4.7 dB	6.3 dB	6.3 dB
Theoretical gain to IF	33.7 dB	35.5 dB	12.9 dB	20.1 dB
Actual Gain to IF	35.0 dB	36.0 dB	21.0 dB	25.5 dB
Theoretical Gain to SP. Anal.	52.1 dB	53.9 dB	31.2 dB	38.5 dB
Actual Gain to Sp. Anal.	53.5 dB	54.0 dB	38.5 dB	43.0 dB
Actual 1 dB Compression (IF) *	-40.0 dBm	-40.7 dBm	-30.0 dBm	-31.2 dBm
Actual 1 dB Compression SP. Anal.	-51.7 dBm	-52.3 dBm	-35.6 dBm	-39.0 dBm

* Note: Additional Gain Amplifiers "OUT"

Table VII. System Performance

VI. CONCLUSION

Construction and testing of the shipboard RFI test package was completed during February 1976. The equipment was taken aboard the U.S. Naval Research Vessel Acania on 21 February 1976. The equipment was operated 24 hours per day while in the San Francisco harbor and while in transit from Monterey to San Francisco and return.

The purpose for this shakedown cruise was to determine if the equipment was operating properly and to develop a set of operating instructions prior to taking the equipment aboard the first ship for testing.

The results of the shakedown cruise were outstanding. The equipment operated as designed with no major changes required.

The equipment has been used to collect data from five operational ships at the time of this writing. No major problems which would have prevented data collection have occurred. The IF box has operated without any failures.

The evaluation of the data gathered will be reported upon in another report; however, it appears that the data will be very useful in characterizing shipboard RFI as it impacts UHF SATCOM and will also be of great value in developing corrective measures to overcome the shipboard RFI.

APPENDIX A. NOISE MEASUREMENT

A. THEORY AND DEFINITIONS

The thermal noise of an amplifier is usually characterized in terms of an equivalent thermal noise source by means of the equation

$$N = K T B \quad (1)$$

where, N = the noise power available at the terminals of the source in watts

K = Boltzmann's constant (1.38×10^{-23} Joules/Kelvin)

T = the equivalent temperature of the source

B = noise bandwidth of the network in Hz.

The noise power at the output of an amplifier or a receiver is given by

$$N_o = K(T_e + T_t) (G_i + G_s) B \quad (2)$$

where, N_o = the noise power available at the output terminal in watts

T_e = the equivalent noise temperature of the receiver or amplifier referenced to the input

T_t = the noise temperature of the input source

G_s = the signal channel gain

G_i = the image channel gain

B = noise bandwidth of network

B. NOISE TEMPERATURE MEASUREMENT

To measure the noise temperature of the shipboard RFI test set, a calibrated noise generator was permanently installed in deck box I.

The noise generator can be remotely switched "in" and "out" of the

system. When the noise generator is switched "in" the noise source can be turned on giving a temperature T_2 or turned off giving a temperature T_1 . The equivalent noise temperature is given by

$$T_e = \frac{T_2 - Y T_1}{Y - 1} \quad (3)$$

where Y is the change in output noise level as a power ratio (i.e., $Y = N_{o2}/N_{o1}$). Thus

$$F = \frac{\frac{T_2}{T_1} - Y \left(\frac{T_1}{T_0} \right) + 1}{Y - 1} \quad (4)$$

If the room temperature is assumed to be the standard reference temperature, (4) reduces to:

$$F = \frac{\left(\frac{T_2}{T_1} - 1 \right)}{Y - 1} \quad (5)$$

The quantity in the numerator is a standard for the noise diode and is known as the Excess Noise Ratio. The Excess Noise Ratio for the noise diode used in the test set expressed in dB is 15.3 dB. The noise figure in dB is given by

$$F_{dB} = ENR_{dB} - 10 \log_{10} (Y-1) \quad (6)$$

where Y is a power ratio.

Figure 24 is a nomograph for calculating the noise figure. To use the nomograph enter with the ENR_{dB} and Y_{dB} and the point where the line crosses the center scale is the noise figure in dB. The Y -factor is obtained by taking the difference in power output in dB when the noise diode is "on" and "off".

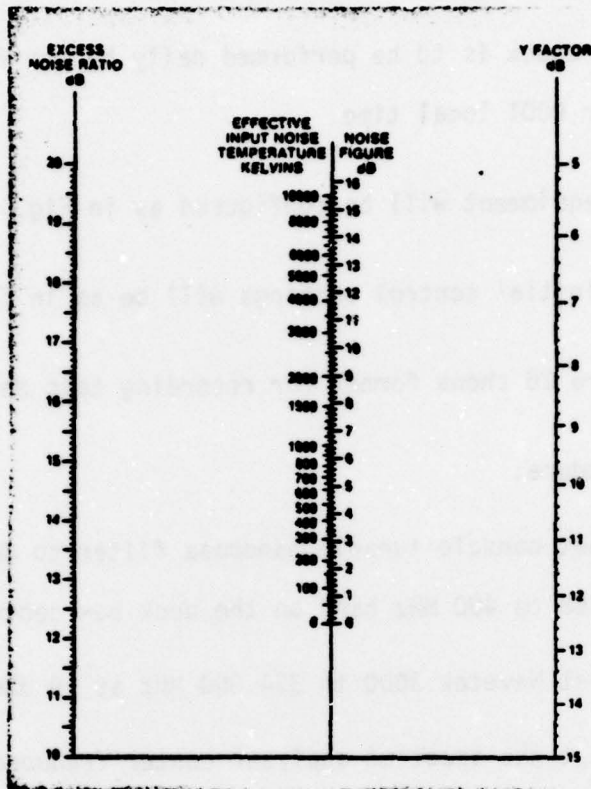

Figure 24. Nomograph for Obtaining Noise Figure

APPENDIX B. DAILY PERFORMANCE TESTING

This appendix discusses the procedure for performing a daily performance check for the overall system.

- A. This check is to be performed daily by the first watch beginning after 0001 local time.
- B. The equipment will be configured as in Fig. 5.
- C. The initial control settings will be as in Table VIII.
- D. Figure 26 shows format for recording test results.
- E. Procedure:
 - 1. Set console tunable bandpass filter to 384 MHz and select the 368 to 400 MHz band on the deck box control.
 - 2. Set Wavetek 3000 to 354.000 MHz at +9 dBm.
 - 3. Set the spectrum analyzer center frequency to 384 MHz.
 - 4. Insuring Antenna/Noise Diode switch is in the Noise Diode position and the Noise Diode is OFF, set the level adjust on the level density analyzer for a reading of 20 μ amps.
 - 5. Depress the sweep trigger on the spectrum analyzer.
 - 6. Turn Noise Diode on.
 - 7. Depress "sweep trigger" on Spectrum Analyzer.
 - 8. Record the difference in dB between the display at the center frequency for the Noise Diode ON and OFF. This is the "Y" factor for the spectrum analyzer.

9. Insert attenuation in the IF box until the meter on the level density analyzer again reads 20 μ amps.
10. The "Y" factor for the system through the IF amplifier is equal to the amount of attenuation required to get the LDA meter to again read 20 μ amps. Record this "Y" factor.
11. Set console tunable bandpass filter to 320 MHz and select the 304 to 336 MHz bank on the deck box control.
12. Set Wavetek 3000 to 290.000 MHz at +9 dBm.
13. Set spectrum analyzer center frequency to 320 MHz.
14. Perform steps 4 through 10 at 320 MHz.
15. Set tunable bandpass filter to 256 MHz and select the 240 - 272 MHz band on the deck box control.
16. Set Wavetek 3000 to 226.000 MHz at +9 dBm.
17. Set spectrum analyzer center frequency to 256 MHz.
18. Perform steps 4 through 10 at 256 MHz center frequency.
19. Switch filter bandwidth on the RF/blanker box to 10 MHz and perform steps 4 through 10 at 256 MHz center frequency.
20. Select 10 KHz filters on IF box and perform steps 4 through 10 at 256 MHz center frequency.
21. Select 3 KHz filters on IF box and perform steps 4 through 10 at 256 MHz center frequency.
22. Insuring no tape in digital recorder, depress the start button on the LDA to initiate a counting cycle.

23. Upon completion of "count period", compare data stored on test circuit board with the LED display on the LDA. Data is cycled into single LED indicator by depressing the momentary "cycle" push button.
24. The order that the data appears is as below.
 - a. code - 1 digit
 - b. time - 6 digit reading from least significant digit to most significant digit
 - c. counter #6 down through counter #1-8 digits reading from most significant to least significant digit.
 - d. blanker counter - 8 digits reading from most significant to least significant digit.

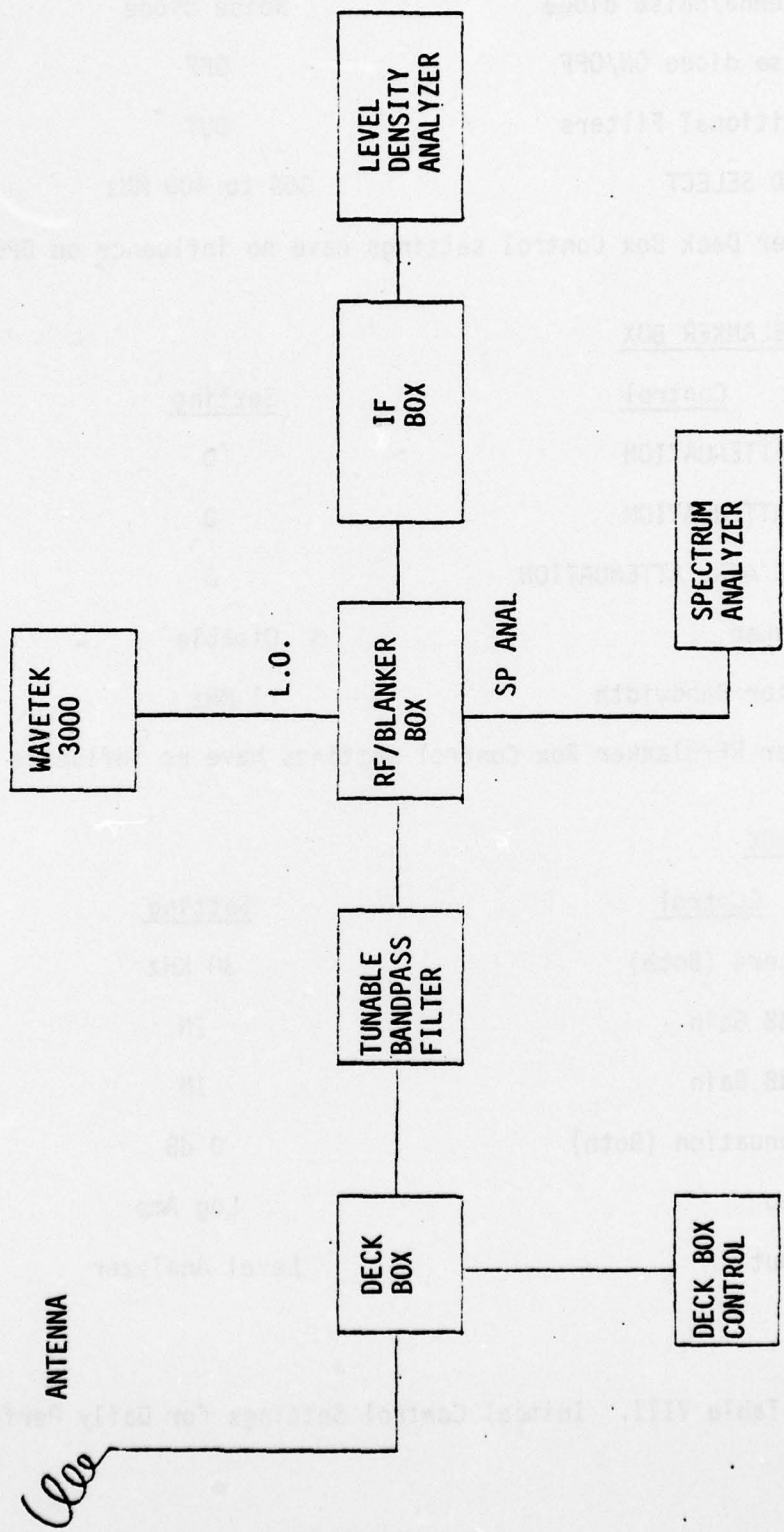

Figure 25. System Configuration for Daily Performance Check

DECK BOX CONTROL

<u>Control</u>	<u>Setting</u>
Antenna/noise diode	Noise Diode
Noise diode ON/OFF	OFF
Additional Filters	OUT
BAND SELECT	368 to 400 MHz

Other Deck Box Control settings have no influence on DPC.

RF/BLANKER BOX

<u>Control</u>	<u>Setting</u>
RF ATTENUATION	0
IF ATTENUATION	0
SPEC ANAL ATTENUATION	0
Blanker	Disable
Filter Bandwidth	1 MHz

Other RF/Blanker Box Control settings have no influence on DPC.

IF BOX

<u>Control</u>	<u>Setting</u>
Filters (Both)	30 KHz
19 dB Gain	IN
28 dB Gain	IN
Attenuation (Both)	0 dB
Video	Log Amp
Output	Level Analyzer

Table VIII. Initial Control Settings for Daily Performance Check

LEVEL DENSITY ANALYZER

<u>Control</u>	<u>Setting</u>
Auto/Manual	Manual
Meter Switch	Level
Period	100
Level Space	3 dB
Test Signal	OFF

SPECTRUM ANALYZER SETTINGS

<u>Control</u>	<u>Setting</u>
Bandwidth	100 KHz
Scanwidth	10 MHz/Div
Input Attenuation	0
Scan Time/Div	1 sec
Log Ref Level	-20 dBm
Presentation	10 dB Log
Video Filter	100 Hz
Scan Mode	Single
Scan Trigger	Auto
Writing Speed	STD
Persistence	Max
Intensity	As required

Table VIII. Initial Control Settings for Daily Performance Check (Cont)

1. 1 MHz Blanker Bandwidth

"Y" Factor

<u>BAND</u>	<u>SP ANAL.</u>	<u>LDA</u>
368-400 MHz	_____ dB	_____ dB
304-336 MHz	_____ dB	_____ dB
240-272 MHz	_____ dB	_____ dB

2. 10 MHz Blanker Bandwidth

"Y" Factor

IF Bandwidth	30 KHz	10 KHz	3 KHz
Band 240-272 MHz	_____ dB	_____ dB	_____ dB

3. Results of tape data test (circle) good/bad.

Notes: 1. The "Y" factor for the spectrum analyzer channel should be greater than 0.5 dB.

2. The "Y" factor for the LDA channel should be greater than 9.5 dB.

Figure 26. Daily Performance Test Sheet (Sample)

APPENDIX C. IF OPERATING PROCEDURES

The IF amplifier can be operated in one of three modes. These modes are wideband, narrowband, and record. Table IX giving the IF control settings for the three modes of operation is provided for ready reference.

A. WIDEBAND MODE

The wideband mode is used for observing widebandwidth signals such as radar signals. The filter select switches will be in the "10 MHz" position for this mode. The 19 dB additional gain must always be "out" for wideband operation. The 28 dB additional gain may be "in" or "out" depending upon the ambient noise level. The output switch will normally be in the "SCOPE" position for this mode.

B. NARROWBAND MODE

The narrowband mode is used for performing statistical analysis of a communications channel using the level density analyzer. The filter selector switches will be in the 3 KHz, 10 KHz, or 30 KHz position, depending upon the channel bandwidth desired. The 19 dB additional gain must be "in" and the 28 dB additional gain may be "in" or "out" depending upon the ambient noise level. The output switch will normally be in the "level analyzer" position for this mode.

C. RECORD MODE

The record mode is used for recording on an analog recorder. The filter selector switches will be in the "FILT 1" position. The 19 dB additional gain must be "out" in the record mode. The 28 dB additional gain must be "in". The output switch will normally be in the "level analyzer" position for this mode.

MODE	CONTROL		SETTINGS		Output	Video	Attenuation
	Filter Select	19dB	28dB				
WIDE	10 MHz	OUT	OUT	Note (1)	SCOPE	LOG IF	0 Note (2)
NARROW	3, 10, or 30 KHZ	IN	OUT	Note (1)	LEVEL ANAL.	LOG IF	0 Note (2)
RECORD	FILT 1	OUT	IN		LEVEL ANAL.	LOG IF	0 Note (2)

NOTES:

(1) May be in or out depending on ambient noise level of the R.F. environment in the band being observed.

(2) Normally 0 but may insert additional attenuation for large signals or if there is a high noise level.

Table IX. IF Control Settings for Various Modes of Operations

LIST OF REFERENCES

- [1] G. B. Parker and J. E. Ohlson, "Deck Boxes for UHF SATCOM Radio Frequency Interference Study", Technical Report, Naval Postgraduate School, Monterey, California, in preparation 1976.
- [2] F. E. Mace, Jr. and J. E. Ohlson, "A High Level Noise Blanker and RF Amplifier System for the UHF Band", Technical Report, Naval Postgraduate School, Monterey, California, in preparation 1976.
- [3] D. C. Arneson and J. E. Ohlson, "A Level Density Analyzer for Shipboard Measurements", Technical Report, Naval Postgraduate School, Monterey, California, in preparation 1976.
- [4] Skolnik, Merrill Ivan, Introduction to Radar Systems, New York: McGraw Hill, p. 363-366, 1962.
- [5] White, Donald R. J., Electromagnetic Interference and Compatibility, Germantown, Md, Don White Consultants, V. 3, 1971.
- [6] Reference Data for Radio Engineers, Indianapolis: Howard W. Sams & Co., Incorporated, 5th Ed., p. 10-4, 1972.

INITIAL DISTRIBUTION LIST

	<u>No. of Copies</u>
1. Defense Documentation Center Cameron Station Alexandria, VA 22314	2
2. Library, Code 0212 Naval Postgraduate School Monterey, CA 93940	2
3. Dean of Research, Code 023 Naval Postgraduate School Monterey, CA 93940	1
4. Chairman, Dept. of Electrical Engineering, Code 62 Naval Postgraduate School Monterey, CA 93940	1
5. Associate Professor J. E. Ohlson, Code 620L Naval Postgraduate School Monterey, CA 93940	25
6. LCDR C. J. Waylan, Code PME 106-111 Naval Electronic Systems Command Washington, D.C. 20360	6
7. LT Dennis C. Arneson, USN 5746 Antigua Blvd. San Diego, CA 92124	1
8. LT Frederick E. Mace, Jr., USN 7 Allen Ave. Machias, Maine 04654	1
9. LT Gary Parker, USN Box 228 Port Orchard, WN 98366	1
10. LT Allen R. Shuff, USN South Bay Towers, Apt. 41 616 G. Street Chula Vista, CA 92010	1
11. Dr. S. Bernstein M.I.T. Lincoln Laboratory P.O. Box 73 Lexington, MA 02173	1
12. Dr. J. Geist Harris Electronic Systems Division P.O. Box 37 Melbourne, FL 32901	1

No. of Copies

13. Dr. P. McAdam
Bldg. R6/1385
TRW Inc.
One Space Park
Redondo Beach, CA 90278

1