

AD-A035 884

NAVAL POSTGRADUATE SCHOOL MONTEREY CALIF
THE DESIGN, CONSTRUCTION, AND IMPLEMENTATION OF A SIMULATED PIL--ETC(U)
SEP 76 D P AYERS

F/G 6/5

UNCLASSIFIED

NL

1 of 1
ADA035884

1

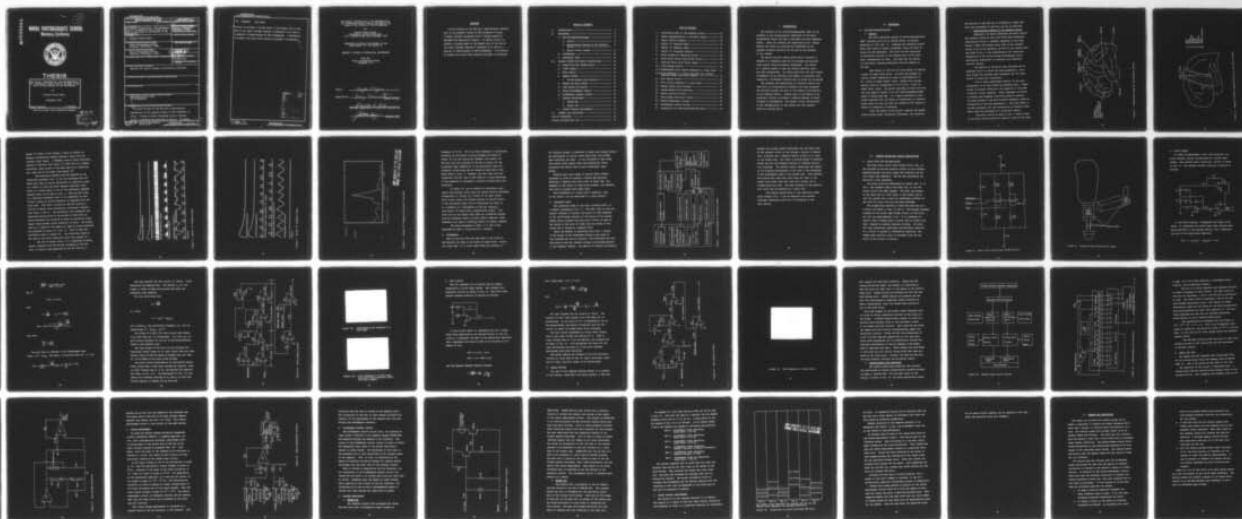

END

DATE
FILMED
3 - 77

ADA 035884

1

2

B.S.

NAVAL POSTGRADUATE SCHOOL

Monterey, California



THESIS

THE DESIGN, CONSTRUCTION, AND IMPLEMENTATION
OF A SIMULATED PILOT'S TASK TO BE USED IN THE
STUDY OF THE EFFECTS OF EEG BIOFEEDBACK

by

Douglas Pierce Ayers

September 1976

Thesis Advisor:

G. Marmont

Approved for public release; distribution unlimited.

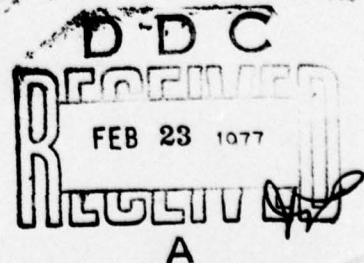

UNCLASSIFIED

SECURITY CLASSIFICATION OF THIS PAGE (When Data Entered)

REPORT DOCUMENTATION PAGE		READ INSTRUCTIONS BEFORE COMPLETING FORM
1. REPORT NUMBER	2. GOVT ACCESSION NO.	3. RECIPIENT'S CATALOG NUMBER 9
4. TITLE (and Subtitle) The Design, Construction, and Implementation of a Simulated Pilot's Task to be Used in the Study of the Effects of EEG Biofeedback		5. TYPE OF REPORT & PERIOD COVERED Master's Thesis September 1976
7. AUTHOR(s) 10 Douglas Pierce Ayers		6. PERFORMING ORG. REPORT NUMBER
9. PERFORMING ORGANIZATION NAME AND ADDRESS Naval Postgraduate School Monterey, California 93940		8. CONTRACT OR GRANT NUMBER(s)
11. CONTROLLING OFFICE NAME AND ADDRESS Naval Postgraduate School Monterey, California 93940		12. REPORT DATE 11 Sep 1976
14. MONITORING AGENCY NAME & ADDRESS (if different from Controlling Office)		13. NUMBER OF PAGES 12 55 p.
		14. SECURITY CLASS. (of this report) Unclassified
		15a. DECLASSIFICATION/DOWNGRADING SCHEDULE
16. DISTRIBUTION STATEMENT (of this Report) Approved for public release; distribution unlimited.		
17. DISTRIBUTION STATEMENT (of the abstract entered in Block 20, if different from Report)		
18. SUPPLEMENTARY NOTES		
19. KEY WORDS (Continue on reverse side if necessary and identify by block number) Simulated Pilot's Task EEG Biofeedback		
20. ABSTRACT (Continue on reverse side if necessary and identify by block number) A brief history of the EEG and a physiological explanation of the possible causes of EEG waveforms is given. A highly reliable simulated pilot's tasking system is designed and explained in detail. An analog		

251 450
499

UNCLASSIFIED

SECURITY CLASSIFICATION OF THIS PAGE(When Data Entered)

(20. ABSTRACT Continued)

→ circuit to produce a voltage equal to the square root of the sum of two input voltages squared is designed to be used as a measure of effectiveness of EEG biofeedback. A discussion of present and future data analysis programs is presented. ↗

ACCESSION for	
DTIC	DTIC Uncl. <input checked="" type="checkbox"/>
DDC	DDC Uncl. <input type="checkbox"/>
UNANNOUNCED	<input type="checkbox"/>
JUSTIFICATION	
BY	
CLASSIFICATION/AVAILABILITY CODES	
Dist.	AVAIL. CODES
A	

DD Form 1473
1 Jan 73
S/N 0102-014-6601

UNCLASSIFIED

SECURITY CLASSIFICATION OF THIS PAGE(When Data Entered)

The Design, Construction, and Implementation
of a Simulated Pilot's Task to be Used in the
Study of the Effects of EEG Biofeedback

by

Douglas Pierce Ayers
Lieutenant, United States Navy
B.S., United States Naval Academy, 1969

Submitted in partial fulfillment of the
requirements for the degree of

MASTER OF SCIENCE IN ELECTRICAL ENGINEERING

from the

NAVAL POSTGRADUATE SCHOOL
September 1976

Author

Douglas P. Ayers

Approved by:

George Marmor
Thesis Advisor

Donald E. Kirk
Chairman, Department of Electrical Engineering

J. M. [Signature]
Academic Dean

ABSTRACT

A brief history of the EEG and a physiological explanation of the possible causes of EEG waveforms is given. A highly reliable simulated pilot's tasking system is designed and explained in detail. An analog circuit to produce a voltage equal to the square root of the sum of two input voltages squared is designed to be used as a measure of effectiveness of EEG biofeedback. A discussion of present and future data analysis programs is presented.

TABLE OF CONTENTS

I.	INTRODUCTION -----	7
II.	BACKGROUND -----	8
	A. THE ELECTROENCEPHALOGRAM -----	8
	1. History -----	8
	2. Physiological Anatomy of the Cerebral Cortex -----	9
	3. Neural Circuit Design -----	12
	B. BIOFEEDBACK -----	18
	C. LABORATORY SETUP -----	19
III.	TASKING SYSTEM AND CIRCUIT DESCRIPTIONS -----	22
	A. FORCE STICK AND PREAMPLIFIERS -----	22
	B. PITCH CIRCUIT -----	25
	C. ROLL CIRCUIT -----	32
	D. RANDOM OUTPUTS -----	33
	1. Pseudo-Random Pulse Generator -----	36
	E. SAMPLE AND HOLD CIRCUIT -----	39
	F. WIEN BRIDGE OSCILLATOR -----	41
	G. RADIUS MEASUREMENT CIRCUIT -----	43
	H. BIOFEEDBACK CONTROL CIRCUIT -----	45
	I. PROGRAM DEVELOPMENT -----	45
	1. TWODET.BFB -----	45
	2. REPLAY.VAR -----	47
	J. FUTURE PROGRAM REQUIREMENTS -----	48
IV.	SUMMARY AND CONCLUSIONS -----	52
	LIST OF REFERENCES -----	54
	INITIAL DISTRIBUTION LIST -----	55

LIST OF FIGURES

1.	Functional Areas of the Cerebral Cortex -----	10
2.	Muscle Representation in the Motor Cortex -----	11
3.	Neural Circuit Diagram -----	13
4.	Neuron "A" Computer Model -----	15
5.	Neuron "B" Computer Model -----	16
6.	Neuron "B" Frequency Spectrum -----	17
7.	Block Diagram of Laboratory Setup -----	20
8.	Force Stick Strain Gage Bridge Circuit -----	23
9.	Side-Arm Force Stick Strain Gages -----	24
10.	Pitch Analog Circuit -----	30
11.A	Underdamped Pitch Circuit Response to a Step Input -	31
11.B	Pitch Response to a Step Input With the Circuit Response Almost Critically Damped -----	31
12.	Roll Analog Circuit -----	34
13.	Roll Circuit Response to a Step Input -----	35
14.	Random Output Block Diagram -----	37
15.	Pseudo-Random Pulse Generator -----	38
16.	Sample and Hold Circuit -----	40
17.	Wien Bridge Oscillator Circuit -----	42
18.	Radius Measurement Circuit -----	44
19.	Biofeedback Control Circuit -----	46
20.	Integration of Cross-Correlated EEG Data -----	49

I. INTRODUCTION

The analysis of the electroencephalogram (EEG) by the students in the bioengineering laboratory of the Naval Postgraduate School has been a continual and ever expanding effort. Under the guidance and supervision of Dr. George Marmont new ideas are proposed and researched by the graduate students working with him and by the students in his classes.

The mental activity taking place while a subject is engaged in a demanding task can be recorded and analyzed using neural signal processing techniques. The design of a tasking system to keep the subject mentally alert has been accomplished. By taking data both with and without biofeedback and by recording the degree of successful task completion, biofeedback theories may be tested and evaluated.

The redesign and construction of previous tasking systems built by bioengineering students into more permanent and reliable systems are part of the author's contribution to the research effort. Another part is the design of an electronic circuit to produce a relative measure of effectiveness of biofeedback. The author's final contribution is the implementation of the system into the research effort to analyze EEG's.

II. BACKGROUND

A. THE ELECTROENCEPHALOGRAM

1. History

The first published account of electroencephalogram (EEG) recording was done by Richard Caton, an English physician in 1875 [Ref. 1]. Although his recording instruments were crude by today's standards, Caton was able to notice two EEG phenomena. The first was the occurrence of electrical activity at the sensory area of the brain when a stimulation was made. The other was the noting of continually changing background activity present in the EEG.

Hans Berger in 1929 was the first person to publish a paper on human brain waves. He noted the presence of regular rhythmic sequences of waves at approximately 10 Hz., which he named "Alpha" waves. Berger also noticed smaller waves at frequencies of 18 to 50 Hz., which he named "Beta" waves. The entire recording of brain activity was also named by Berger to be the "Elektrenkephalogramm" which he abbreviated EEG. In a report published in 1931 Berger reported that the effect of stimulation in reducing alpha waves all over the head was related to the subject's amount of attention or alertness.

With the advent of the digital computer and modern sophisticated signal processing techniques, the recording

and analysis of the EEG has so increased in speed that real time processing of EEG data can now be realized.

2. Physiological Anatomy of the Cerebral Cortex

Reference 2 by Guyton describes the motor area of the cerebral cortex as that area which when stimulated electrically elicits a movement somewhere in the body. Figure 1 shows the primary motor area of the cerebral cortex to be in the posterior portion of the frontal lobe. The areas of Fig. 1 were determined by the electrical stimulation of the cortex during neurosurgery and by neurological examination of patients with destroyed cortical regions.

The portion of the motor area characterized by pyramidal cells is called the area pyramidalis. This area causes the greatest motor movements for the least amount of electrical stimulation.

One to three centimeters anterior to the area pyramidalis is an area called the premotor area. Longer trains of greater stimulation are required in this area to elicit a motor response. These responses are slower to develop and movements involving groups of muscles are made instead of the more discrete movements caused by stimulation of the area pyramidalis. This area seems to be more concerned with the coordination of muscular movements than with movements of a particular muscle.

The motor cortex as shown in Fig. 2 labels areas of the motor cortex related to specific areas of the body.

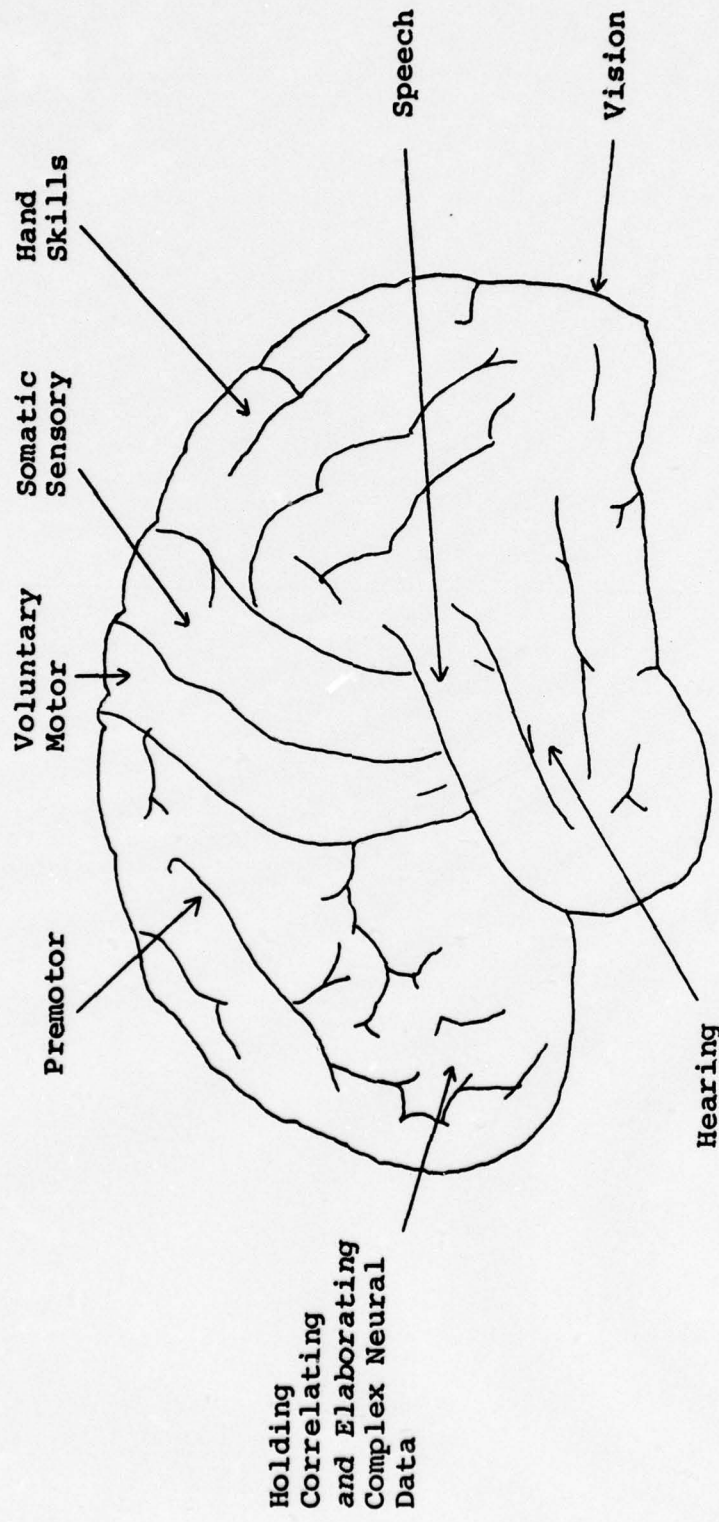

Figure 1. Functional Areas of the Cerebral Cortex.

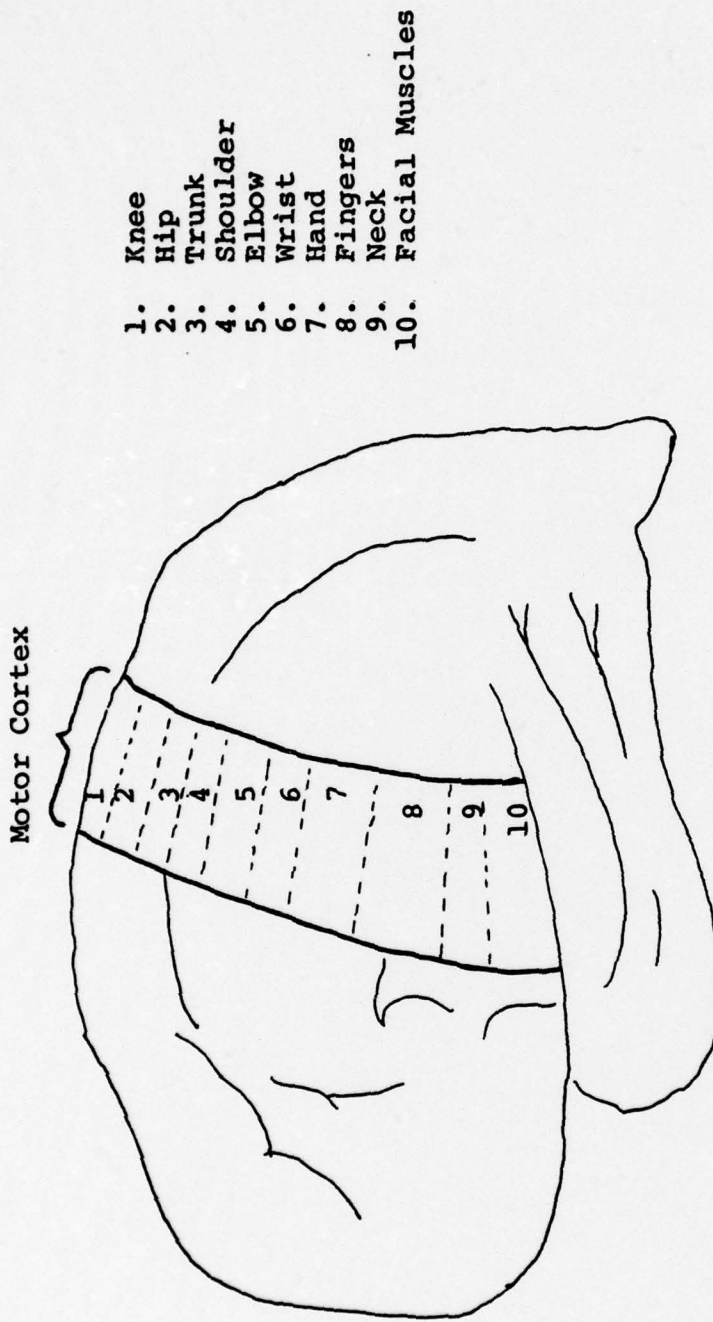

Figure 2. Degree of Muscle Representation in the Motor Cortex.

A movement in one particular part of the body will be caused by neural activity in the corresponding portion of the motor cortex.

3. Neural Circuit Design

The actual cause for brain waves to take their characteristic shapes is not known but may be theorized and a simple circuit can be modeled by computer.

The junction between one neuron and the next is termed a synapse. The three major parts of a nerve cell are the main body called the soma, the axon which conducts the output pulse to either another nerve cell or to a peripheral effector such as a muscle or gland, and the dendrites which are short projections extending from the soma. The dendrites of a neuron can receive both inhibitory and excitatory inputs. Excitatory inputs raise the membrane potential across the axon hillock which is the most sensitive part of the soma. Inhibitory inputs cause a lowering of the potential across the axon hillock. When the potential across the axon hillock is raised to approximately -60 mv., (the threshold level) from -85 mv., (the resting potential), there is a rapid depolarization of the nerve axon. This rapid depolarization is called an action potential which is conducted as an output by the axon. The potential measured across the axon hillock membrane is called the post synaptic potential.

The neural circuit diagram in Fig. 3 has a random input to neuron "A". This input causes an output from

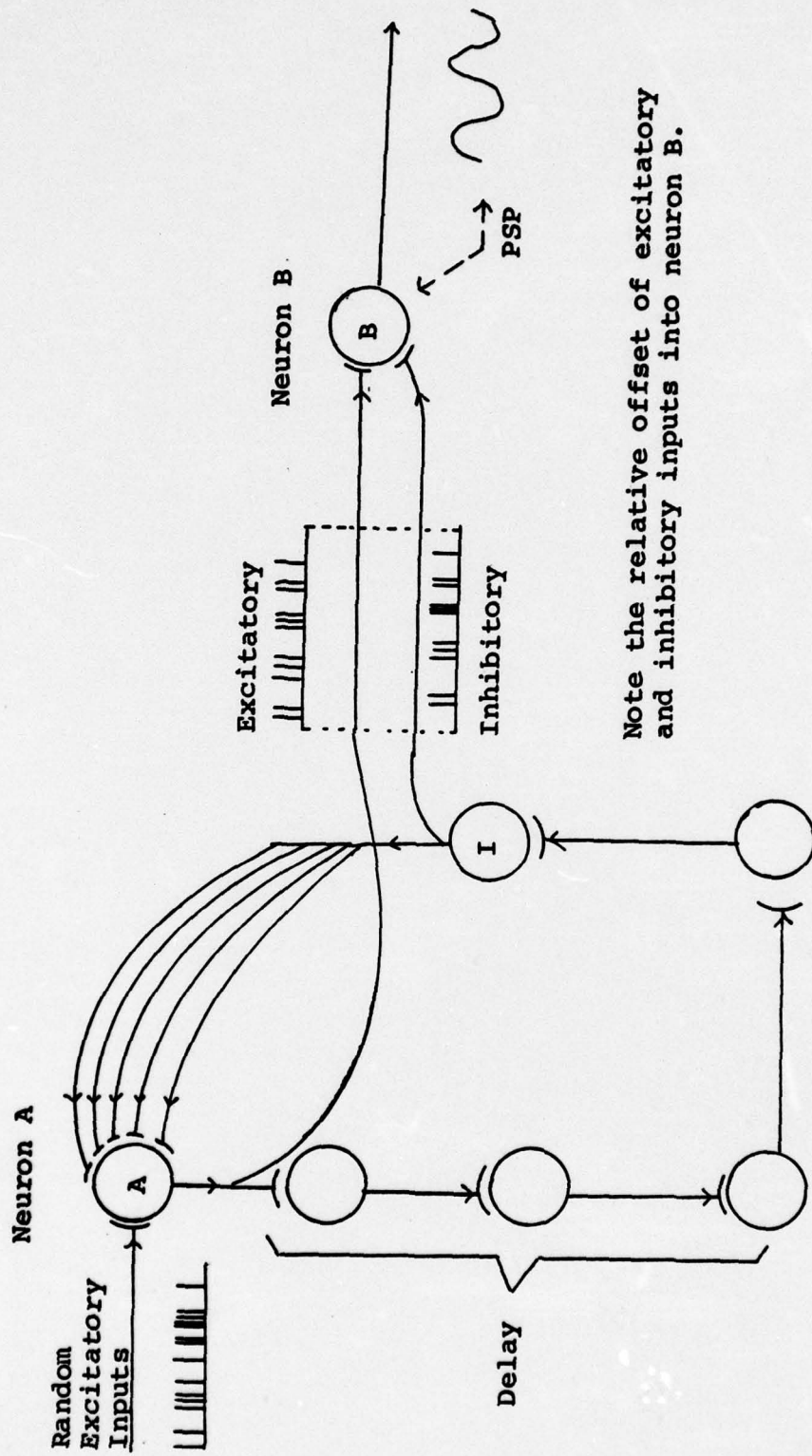

Note the relative offset of excitatory and inhibitory inputs into neuron B.

Figure 3. Neural Circuit Diagram.

neuron "A" which is fed through a train of neurons by synaptic transmission thereby causing a delay from the original input signal. A feedback loop of three inhibitory neurons is fed back into neuron "A" such that if a random excitatory input occurs at the same time as an inhibitory one, there can be no output from neuron "A".

The excitatory exponent and the negative of the inhibitory exponents [Fig. 4] are the waveforms that are added each time you get an excitatory or inhibitory input to a neuron to yield the post synaptic potential (PSP). There is a slight delay in two of the inhibitory feedback signals which can be seen in Fig. 4. When the PSP rises to a specified threshold level it is considered to have "Fired" causing an action potential to propagate down the nerve axon. This point is shown on the PSP curve by a vertical straight line followed by a horizontal straight line [Figs. 4 and 5]. The horizontal line represents the refractory period which is the period of time after an action potential has occurred in which an excitatory input cannot cause another action potential to occur. The bottom trace is a record of the number of times an action potential has occurred in neuron "A" [Fig. 4]. This is then the excitatory input to neuron "B". The inhibitory input is the same as the first inhibitory input into neuron "A".

The PSP of neuron B [Fig. 5] is recognized as being rather sinusoidal and the Fourier transform of the PSP [Fig. 6] shows a high magnitude of the PSP curve at a

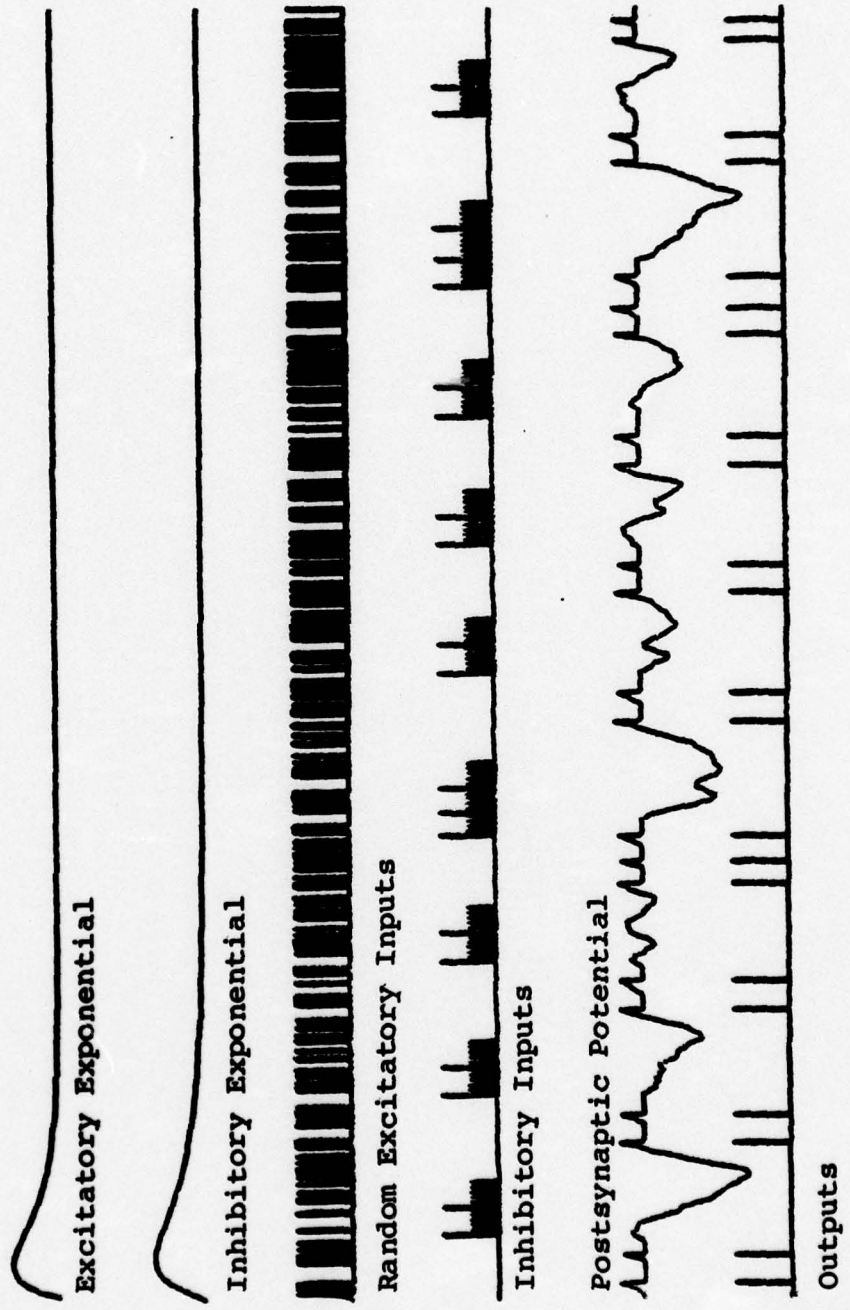

Figure 4. Neuron "A" Computer Model.

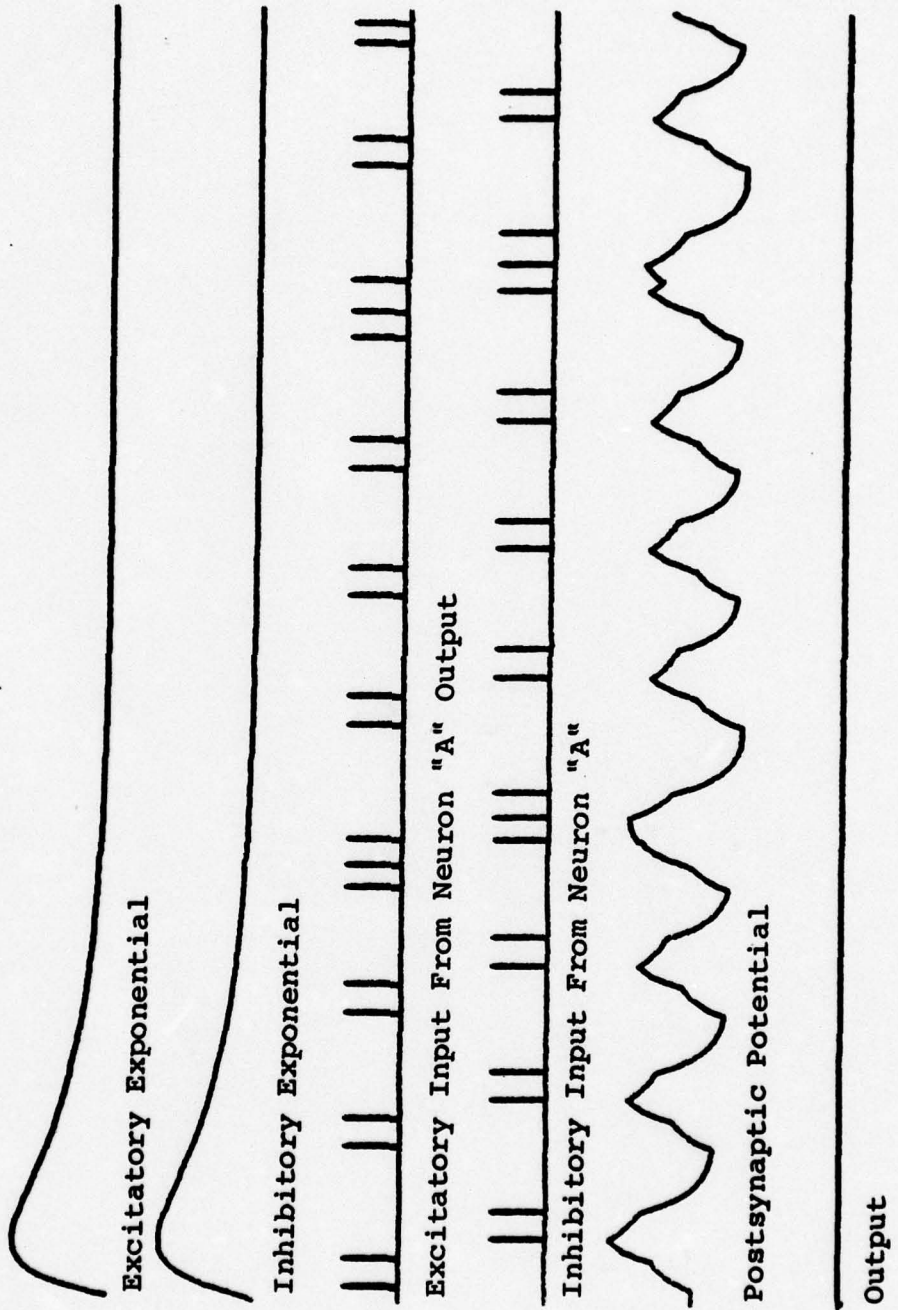
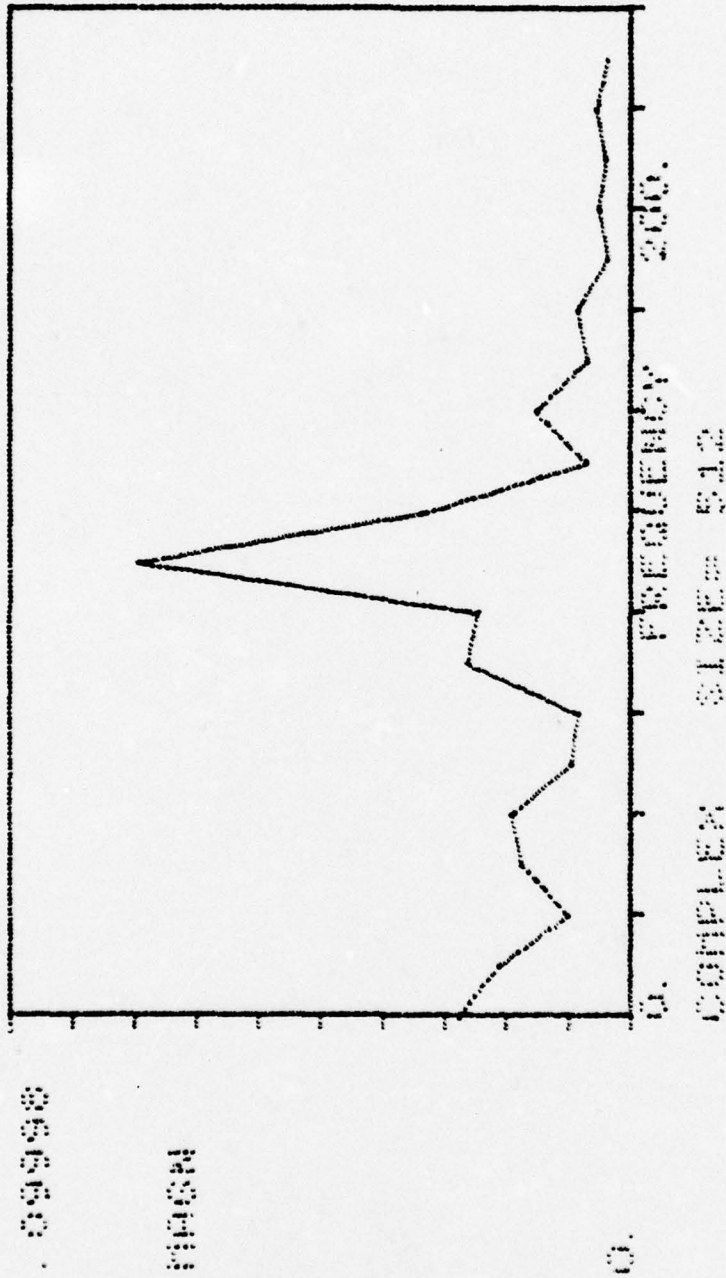

Figure 5. Neuron "B" Computer Model.



**COPY AVAILABLE TO DDC DOES NOT
PERMIT FULLY LEGIBLE PRODUCTION**

Figure 6. Neuron "B" Frequency Spectrum of the PSP.

frequency of 90 Hz. This sine wave frequency is controlled primarily by the amount of delay between the output of neuron "A" and the inhibitory feedback into neuron "A". The fact that the waveform of the PSP of neuron "B" was sinusoidal adds credibility to the postulation that the formation of EEG waves may be caused as described in the model shown in Fig. 3. However, one must take into consideration the fact that an EEG taken by a scalp electrode is the summation of thousands of neurons located below the electrode.

If neuron "B" was to receive an excitatory input signal from another source then the neuron would be extremely susceptible to "firing" as a result of an input signal which occurs during the highest portion of the PSP curve. If the excitatory input rate of occurrence was equal to or a harmonic or a subharmonic of the PSP frequency then neuron "B" would have a synchronized output. This gives rise to the theory that there are preferred frequencies for different neural circuits where a specific input frequency will cause a receiving neuron to readily respond.

The plots presented in Figs. 4, 5, and 6 were developed by LCDR J. Fricke and LT B. Cornett.

B. BIOFEEDBACK

Much of the work that has been done in the field of EEG analysis has been in the study of alpha waves. During one study [Ref. 3] in which alpha waves were present in

all subjects tested, a recording of alpha wave changes during the performance of various tasks under open- and closed-eyed conditions was made. It was concluded in that study that mental tasks reduce alpha wave production, which reinforces the belief held by most researchers since Berger.

Subjects have been taught to control their thought processes in order to produce a certain EEG waveform. Reference 4 reported that when given an audio tone bio-feedback of the amount of alpha waves present, the subjects were able to produce more alpha waves.

The biofeedback of a light bulb's intensity, used by the author, will be described in a later section.

C. LABORATORY SETUP

The laboratory setup in use while recording EEG's is a complex arrangement [Fig. 7]. The basic idea is that the subject attempts to maintain the point of light produced on the oscilloscope directly in the center of the screen. Random inputs displace the point and a record is made of the radius of the point of light from the center of the screen and is stored on a magnetic disc.

While the subject is performing this task, a record of the output of the electrodes placed on the scalp is also recorded and can be analyzed. The electrodes are also monitored on the four channel storage oscilloscope mounted in the computer console. The amount of waveform correlation

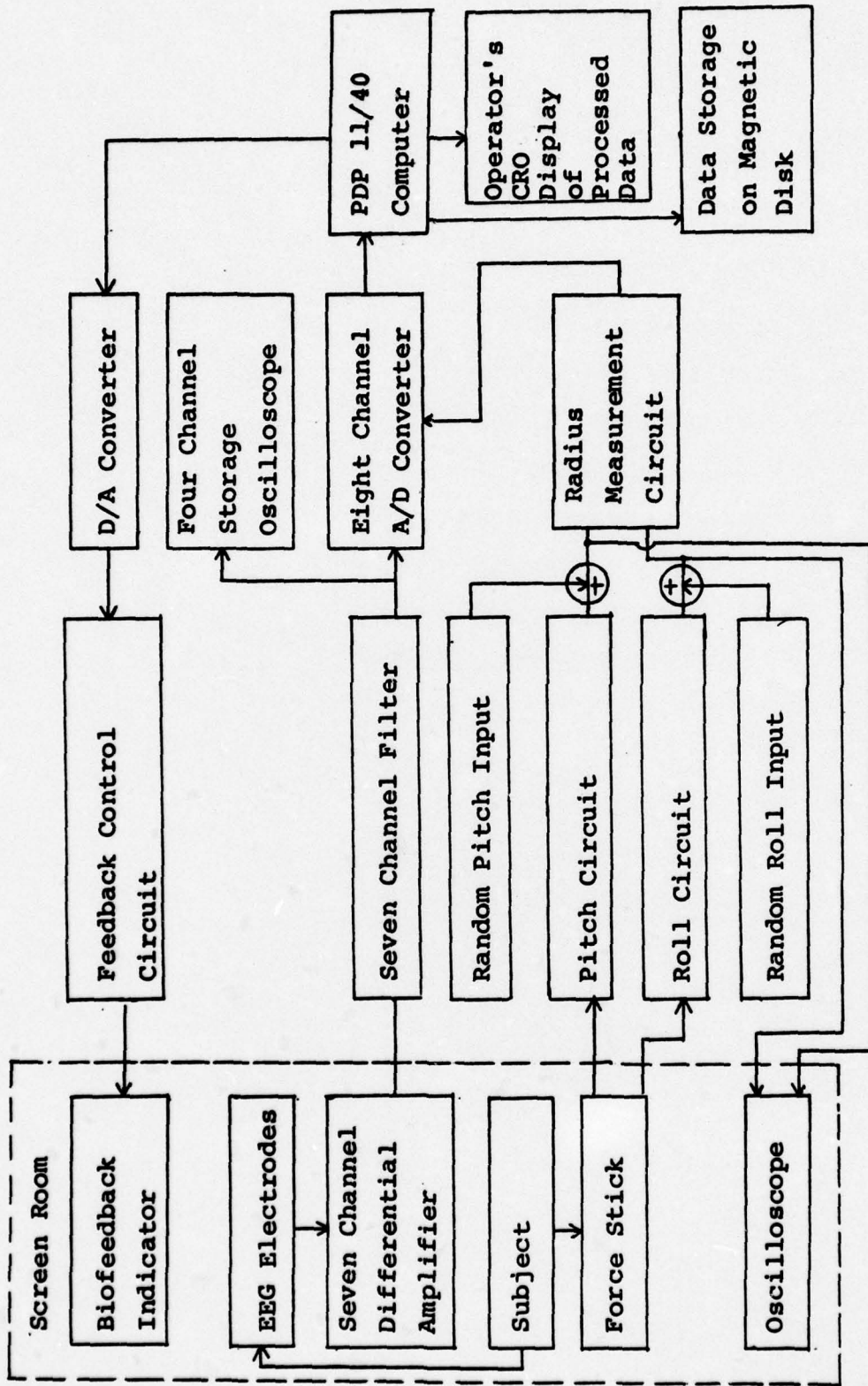

Figure 7. Block Diagram of Laboratory Setup.

between two closely spaced electrodes over the motor area of the cerebral cortex is fed through a digital to analog (D/A) converter and a feedback control circuit to a light in the screen room. The light is placed behind a diffusing screen and the room becomes brighter as waveform correlation increases. The subject readily associates the degree of his attentive performance of the task to the brightness of the biofeedback light in the screen room. Past subjects have stated that when they could keep the light in the screen room bright they felt they did a better job of accomplishing the task. The data recorded on the magnetic disc could then be examined at a later time.

The tasking system shown in the laboratory setup block diagram [Fig. 7] can be separated into several different components which will be discussed in the next section.

III. TASKING SYSTEM AND CIRCUIT DESCRIPTIONS

A. FORCE STICK AND PRE-AMPLIFIERS

The force stick strain gage bridge circuit [Fig. 8] was designed to provide accurate control of the voltages measured between the pitch output and reference and the roll output and reference. The 464 ohm resistances are precision 5 watt resistors.

The force stick was constructed by Layton [Ref. 5] in 1970. The hardware used is the same [Fig. 9] but the bridge circuit has been changed. The stick was mounted as the right arm of a soft chair in the screen room so that the subject had a rigid but comfortable platform to use while his brain activity was being recorded.

The preamplifier sections of both the pitch and roll circuits are shown in Figs. 10 and 12. The maximum voltages produced by the strain gage bridge circuit in both pitch and roll are approximately ± 1 mv. It is necessary to amplify these voltages prior to using them as inputs into their respective transfer function circuits. By using FET input operational amplifiers and precision resistors in a circuit to produce a differential amplifier, the common mode rejection ratio is extremely high and the drift of the circuit is minimal.

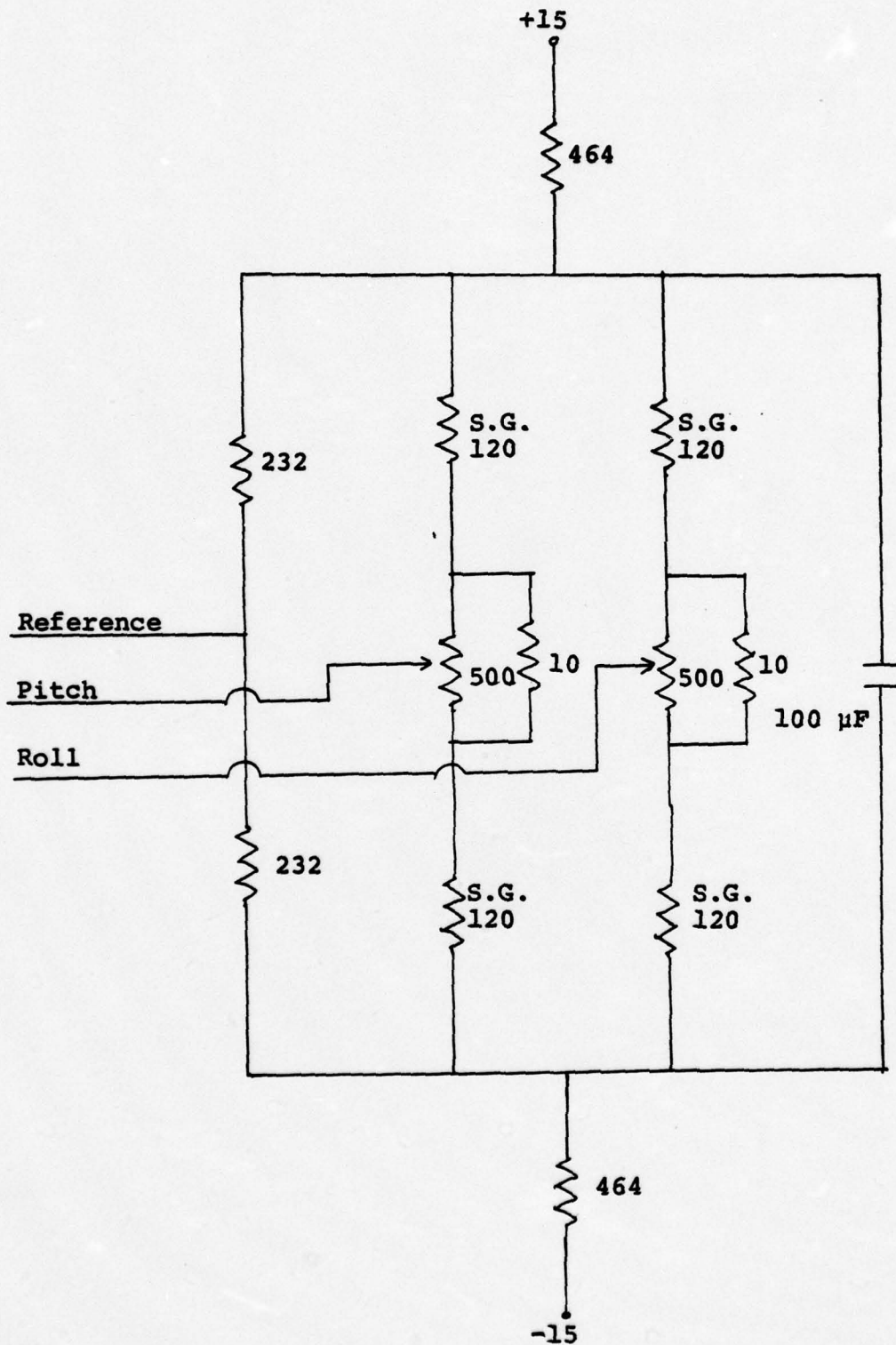

Figure 8. Force Stick Strain Gage Bridge Circuit.

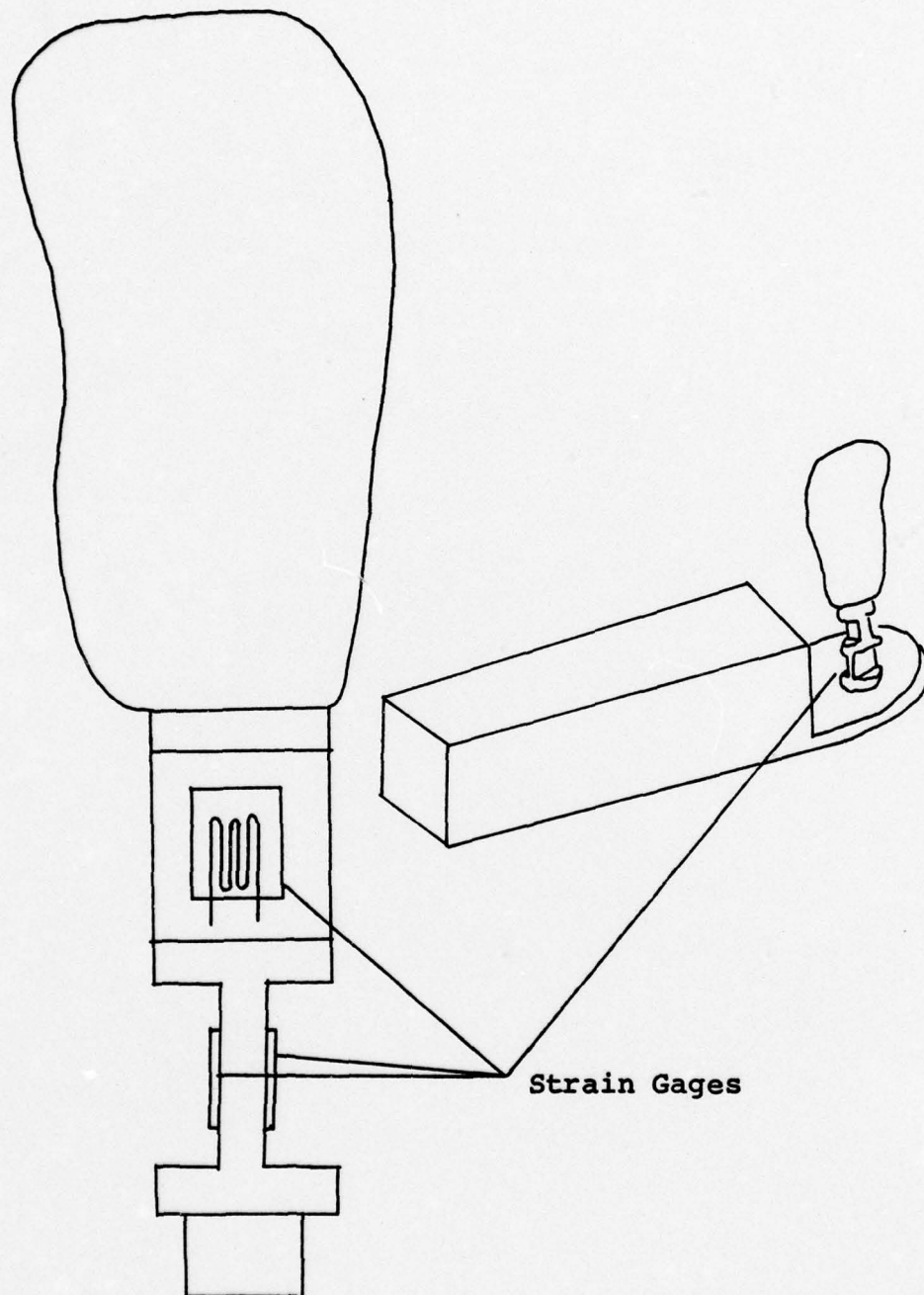
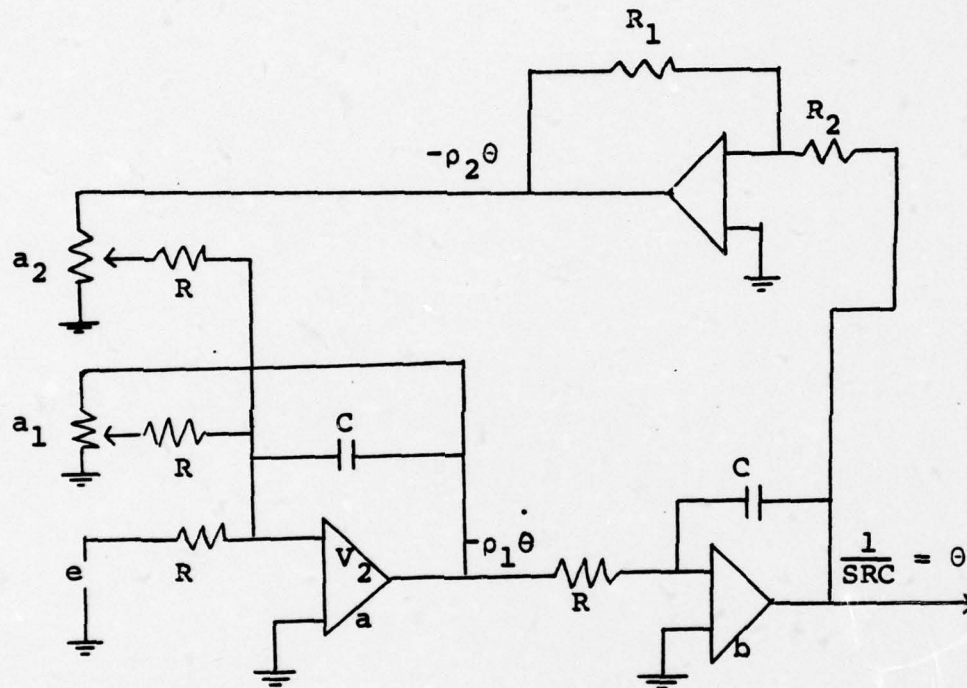

Figure 9. Side-Arm Force Stick Strain Gages.

B. PITCH CIRCUIT

In order to approximate a real life situation, the pitch transfer circuit was designed as a second order system. The aircraft pitch simulation circuit is shown in Fig. 10. The Laplace transfer function is derived as follows:



In the above diagram, θ represents the output pitch angle, "e" represents the strain gage input voltage after being amplified in the pre-amp section, and ρ represents the gain of the operational amplifier.

$$\ddot{\theta}(t) = -a_1 \rho_1 \dot{\theta}(t) - a_2 \rho_2 \theta(t) + e(t)$$

For zero initial conditions, we have

$$a_2 \rho_2 \theta(s) + \rho_1 (a_1 + SRC) \dot{\theta}(s) - E(s) = 0$$

and

$$\rho_1 \dot{\theta}(s) = SRC \theta(s)$$

$$E(s) = [a_2 \rho_2 + a_1 SRC + (SRC)^2] \theta(s).$$

The Laplace transfer function becomes

$$\frac{\theta(s)}{E(s)} = \frac{1}{(RC)^2 \left[s^2 + \frac{a_1 s}{RC} + \frac{a_2 \rho_2}{(RC)^2} \right]} = \frac{1}{(RC)^2 (s+\alpha)(s+\gamma)}$$

where

$$\alpha, \gamma = \frac{1}{2RC} (a_1 \pm \sqrt{a_1^2 - 4a_2 \rho_2}).$$

For a step function input $e(t) = E \cdot u(t)$

$$\theta(t) = \frac{E}{(RC)^2} \left[\frac{1}{\alpha\gamma} + \frac{\gamma e^{-\alpha t} - \alpha e^{-\gamma t}}{\alpha\gamma(\alpha-\gamma)} \right]$$

$$\alpha\gamma = \frac{a_2 \rho_2}{(RC)^2}, \quad \alpha - \gamma = \frac{\sqrt{a_1^2 - 4a_2 \rho_2}}{RC}$$

and let

$$\sqrt{v} = \sqrt{a_1^2 - 4a_2\rho_2} .$$

So

$$\theta(t) = \frac{E}{a_2\rho_2} \frac{1 + e^{\frac{-a_1 t}{2RC}}}{2\sqrt{v}} [(a_1 - \sqrt{v}) e^{\frac{-\sqrt{v}t}{2RC}} - (a_1 + \sqrt{v}) e^{\frac{\sqrt{v}t}{2RC}}].$$

Consider the overdamped case if

$$4a_2\rho_2 > a_1^2,$$

then

$$\theta(t) = \frac{E}{a_2\rho_2} [1 - e^{\frac{-a_1 t}{2RC}} (\cos \frac{\sqrt{-v}t}{2RC} + \frac{a_1}{\sqrt{-v}} \sin \frac{\sqrt{-v}t}{2RC})]$$

Now consider the critically damped case where

$$a_1^2 = 4a_2\rho_2,$$

then

$$\alpha = \gamma$$

so

$$\frac{\theta(s)}{E(s)} = \frac{1}{(RC)^2 (s + \alpha)^2}$$

and if

$$e(t) = E u(t)$$

with

$$\alpha = \frac{a_1}{2RC}, \quad a_1 = 2 \sqrt{a_2 \rho_2}$$

$$\theta(t) = 4E \left[\frac{1 - \left(1 + \frac{a_1 t}{2RC}\right) e^{-\frac{a_1 t}{2RC}}}{a_1^2} \right]$$

Note that

$$\frac{4E}{a_1^2} = \frac{E}{a_2 \rho_2}$$

The last case to consider is the underdamped case where $a_1^2 > 4a_2 \rho_2$ and where v is positive and $e(t) = E u(t)$

$$\theta(t) = \frac{E}{a_2 \rho_2} \left[1 - e^{-\frac{a_1 t}{2RC}} \left(\cosh \sqrt{v} + \frac{a_1}{\sqrt{v}} \sinh \sqrt{v} \right) \right]$$

The time constant for the circuit is $2RC/a_1$, which determines the damping time. The smaller a_1 is, the longer it takes to damp oscillations and reach the asymptotic step response.

For the oscillatory case

$$\omega_0 = \frac{\sqrt{-v}}{2RC}$$

or, since

$$-v = -(a_1^2 - 4a_2\rho_2),$$

for a fixed a_1 , the oscillation frequency, f_0 , will be proportional to $(4a_2\rho_2 - a_1^2)^{1/2}$.

The values of R and C for this circuit were chosen to be 215K ohms and .47 microfarads. " a_1 " and " a_2 " are gain factors obtained via the two 1K ohm potentiometers found in the feedback loop.

The final stage of the pitch circuit provides for additional random inputs or an input signal from any other source, such as from the heads up display test set [Ref. 6], to be added to the total pitch voltage.

The pitch circuit performed as an oscillatory second order system when a step input voltage was applied. When an input voltage step of .8 mv. was applied the response was shown in Fig. 11 A. The photograph in Fig. 11 B was taken with different settings on a_1 and a_2 to show that various degrees of damping can be achieved.

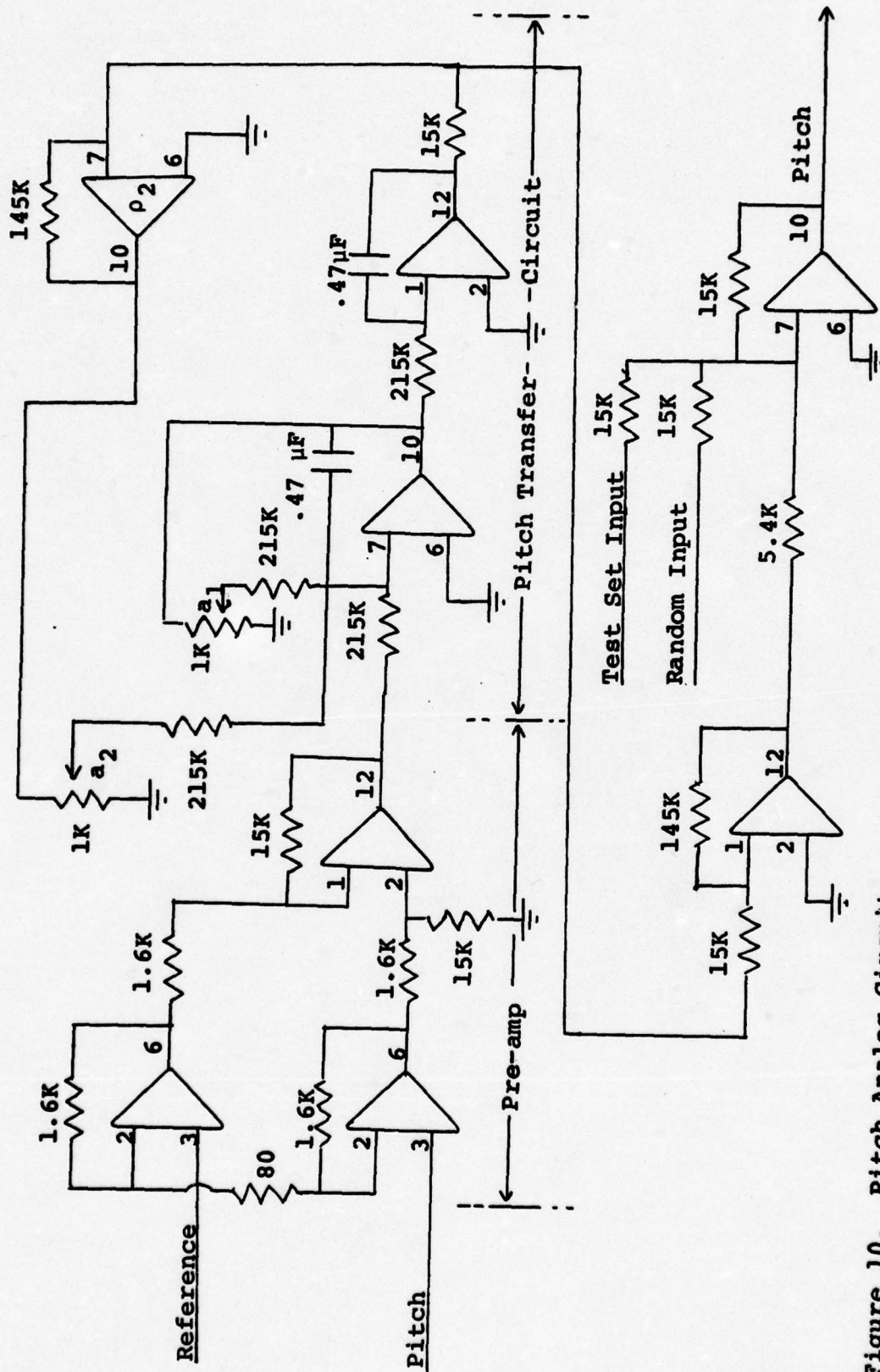

Figure 10. Pitch Analog Circuit.

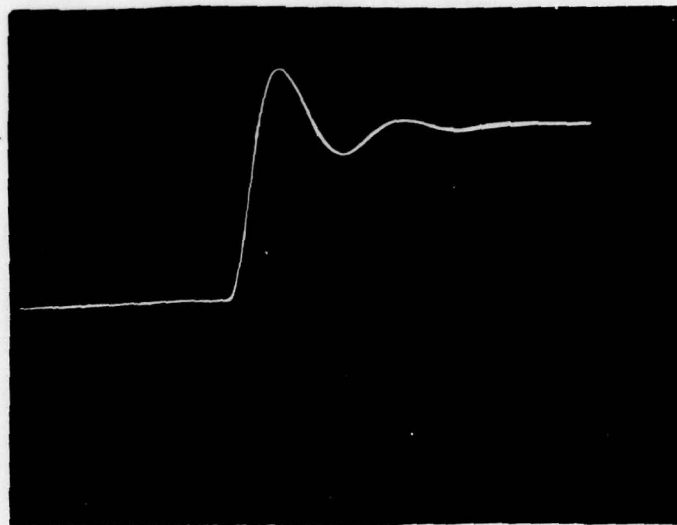

Figure 11A. Underdamped Pitch Response to a Step Input

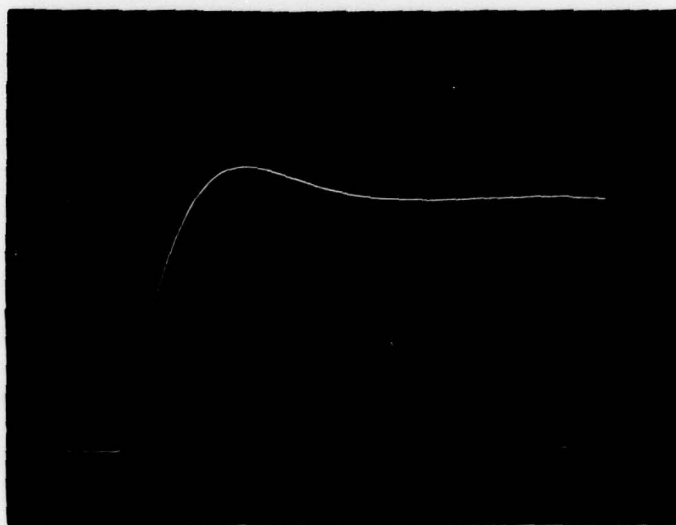
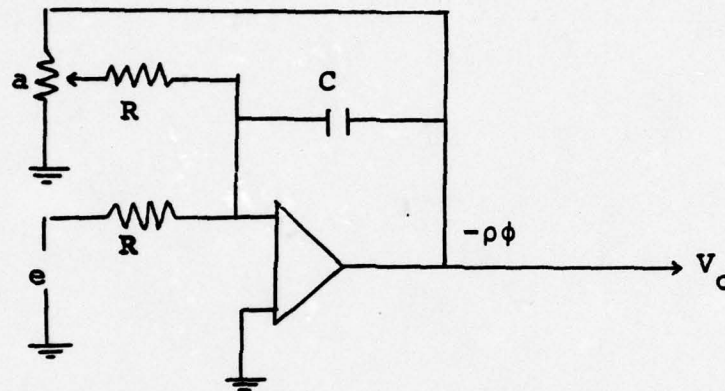

Figure 11B. Pitch Response to a Step Input with the Circuit Response Almost Critically Damped

C. ROLL CIRCUIT

The roll response of an aircraft can be closely simulated by a first order system. The aircraft roll simulation circuit is shown in Fig. 12. The first order Laplace transfer function is derived as follows:



In the circuit above "e" represents the roll voltage after being amplified by the pre-amp section of the roll circuit, ρ represents the gain of the operational amplifier, and ϕ represents the angle of bank of an aircraft or its degree of roll.

$$\dot{\phi}(t) = a \phi(t) + e(t)$$

$$E(S) = (a + SRC) \rho \phi(S)$$

and the Laplace transfer function becomes

$$-\rho \frac{\phi(S)}{E(S)} = -\frac{1}{RC} \cdot \frac{1}{S + \frac{a}{RC}} \cdot$$

For a step input $e(t) = E u(t)$,

$$V_o(s) = \frac{-E(s)}{RC} \cdot \frac{1}{s(s + \frac{a}{RC})}$$

and

$$V_o(t) = \frac{-E}{RC} \cdot \frac{1 - e^{-\frac{at}{RC}}}{\frac{a}{RC}} = -\frac{E}{a} (1 - e^{-\frac{at}{RC}})$$

The time constant for the circuit is "RC/a". The values of R and C were chosen to be 215K ohms and .47 microfarads. As the value of "a" is decreased by the 1K ohm potentiometer the amount of required time for the circuit to equal its steady state value increases.

The roll circuit performed as a first order system when a step input voltage was applied to it. When an input voltage step of .8 mv was applied, the response was as shown in Fig. 13. This photograph was made with the same oscilloscope settings as in the pitch response photographs previously mentioned.

The author applied the outputs of the roll and pitch circuits by using them as the "X" input (horizontal input) and "Y" input (vertical input) of an oscilloscope.

D. RANDOM OUTPUTS

The goal of the complete tasking system is to present to the subject, whose EEG's are being studied, a task that

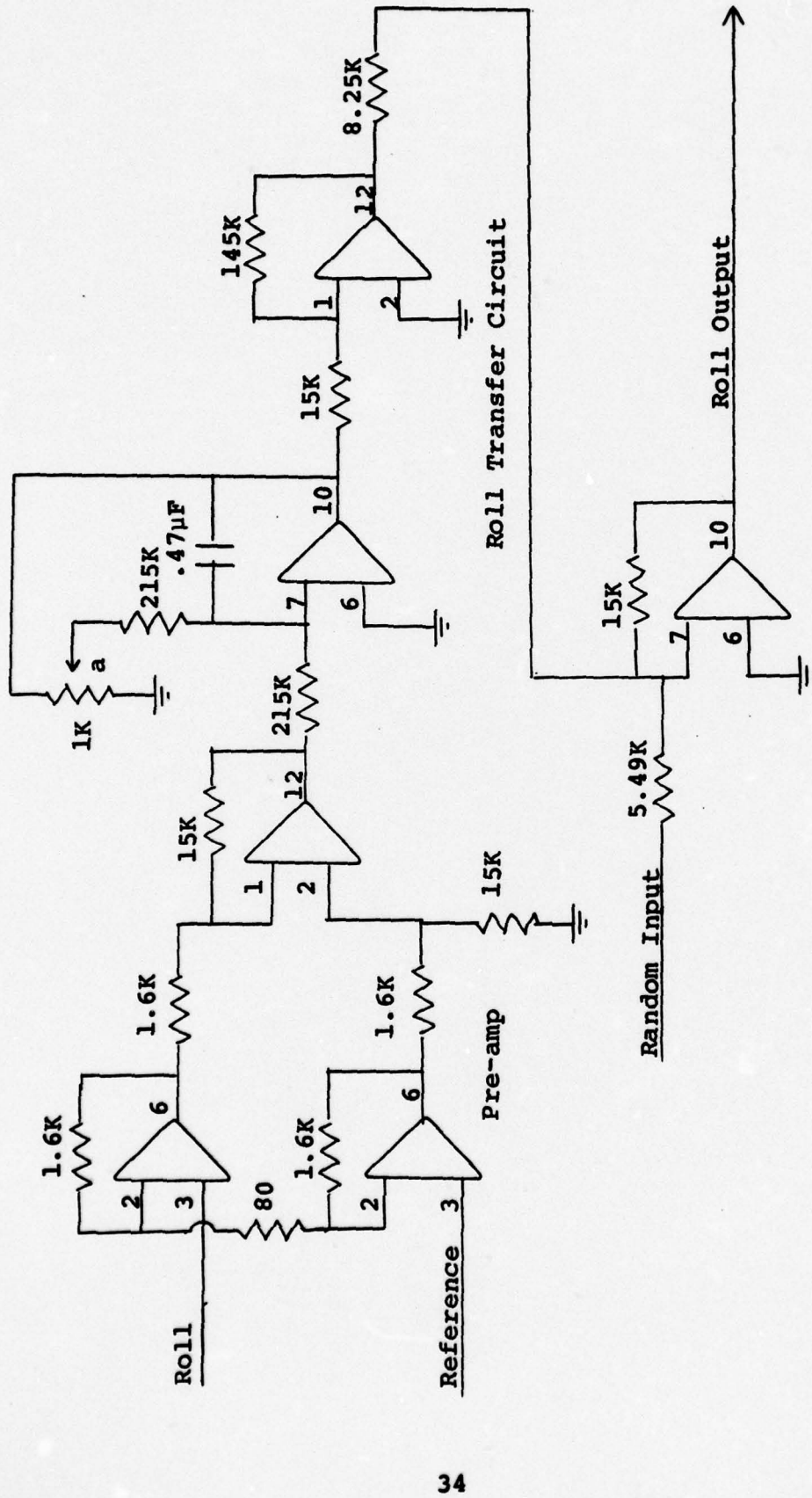

Figure 12. Roll Analog Circuit.

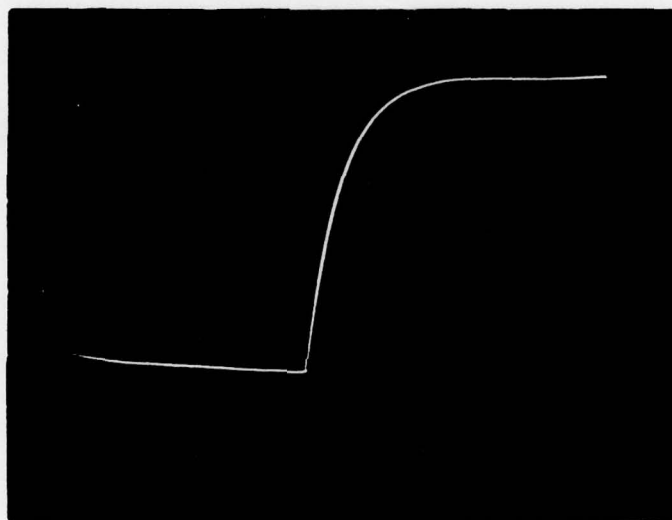

Figure 13. Roll Response to a Step Input.

will require his undivided attention. Before the EEG testing period has begun, the subject is instructed to keep the point of light (pip) in the center of the oscilloscope grid. Random outputs are produced and fed into the oscilloscope grid. Random outputs are produced and fed into the oscilloscope at seemingly random intervals to make a displacement, which the subject must correct by use of the force stick.

The block diagram of the random output subsystem [Fig. 14] gives an easily understood overview of the origin of the output. A pseudo-random binary counter is wired to a one-shot multivibrator which in turn provides a pulse to two sample and hold circuits. Upon receiving the pulse the sample and hold circuits instantaneously sample two oscillator circuits. During the EEG runs frequencies of 5 and 7 Hz were applied respectively to roll and pitch. Since these frequencies are not harmonically related the resultant perturbation of the pip appears to be random both in magnitude and angle. These samples are then added to the pitch and roll circuit values which have been produced by the force stick. Finally, the sums are fed into the oscilloscope's vertical and horizontal inputs.

1. Pseudo-Random Pulse Generator

The pseudo-random pulse generator was designed and constructed by another bioengineering graduate student, LT James L. McClane USN. The six basic parts of the design, as shown in Fig. 15, are three exclusive-or gates,

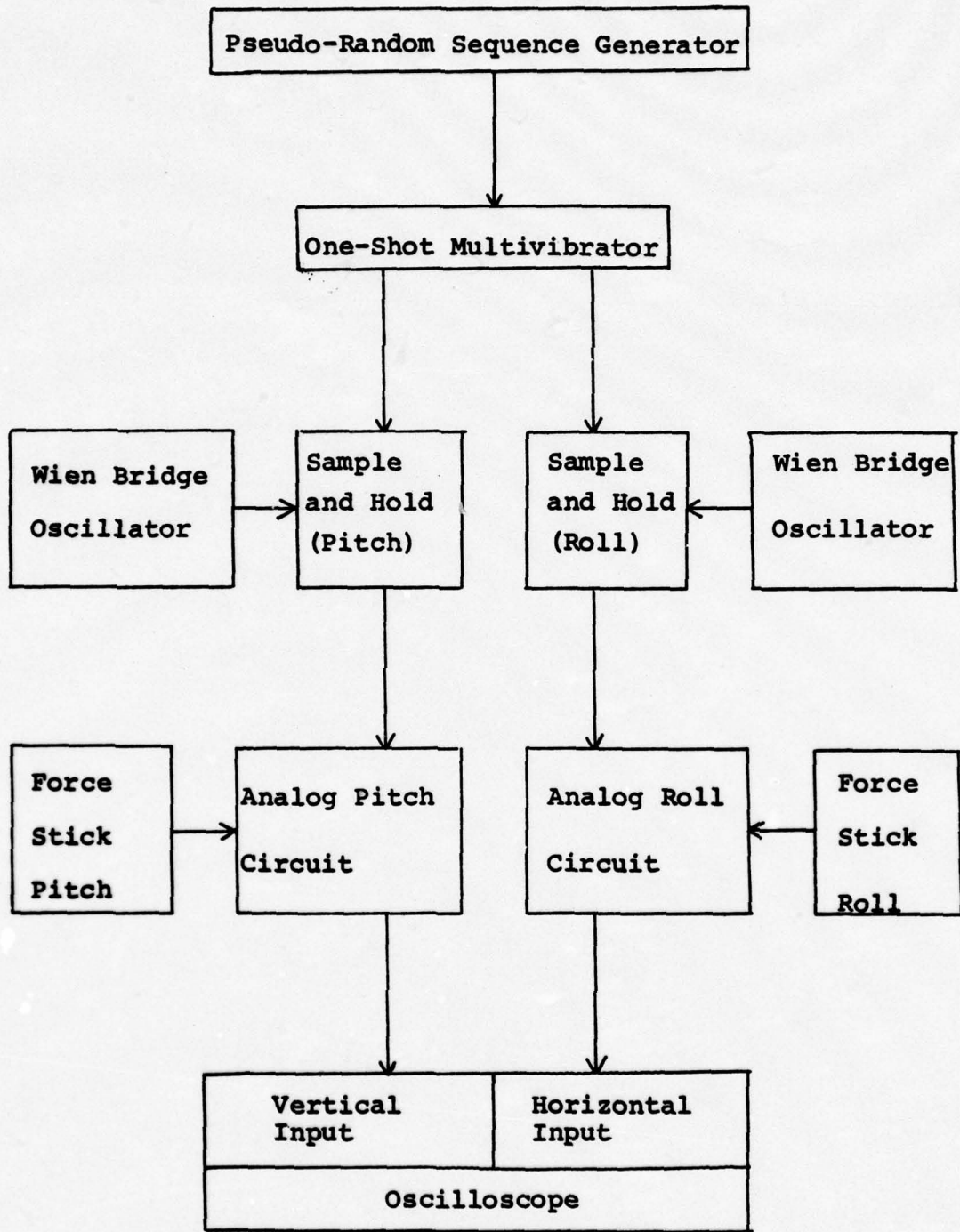

Figure 14. Random Output Block Diagram.

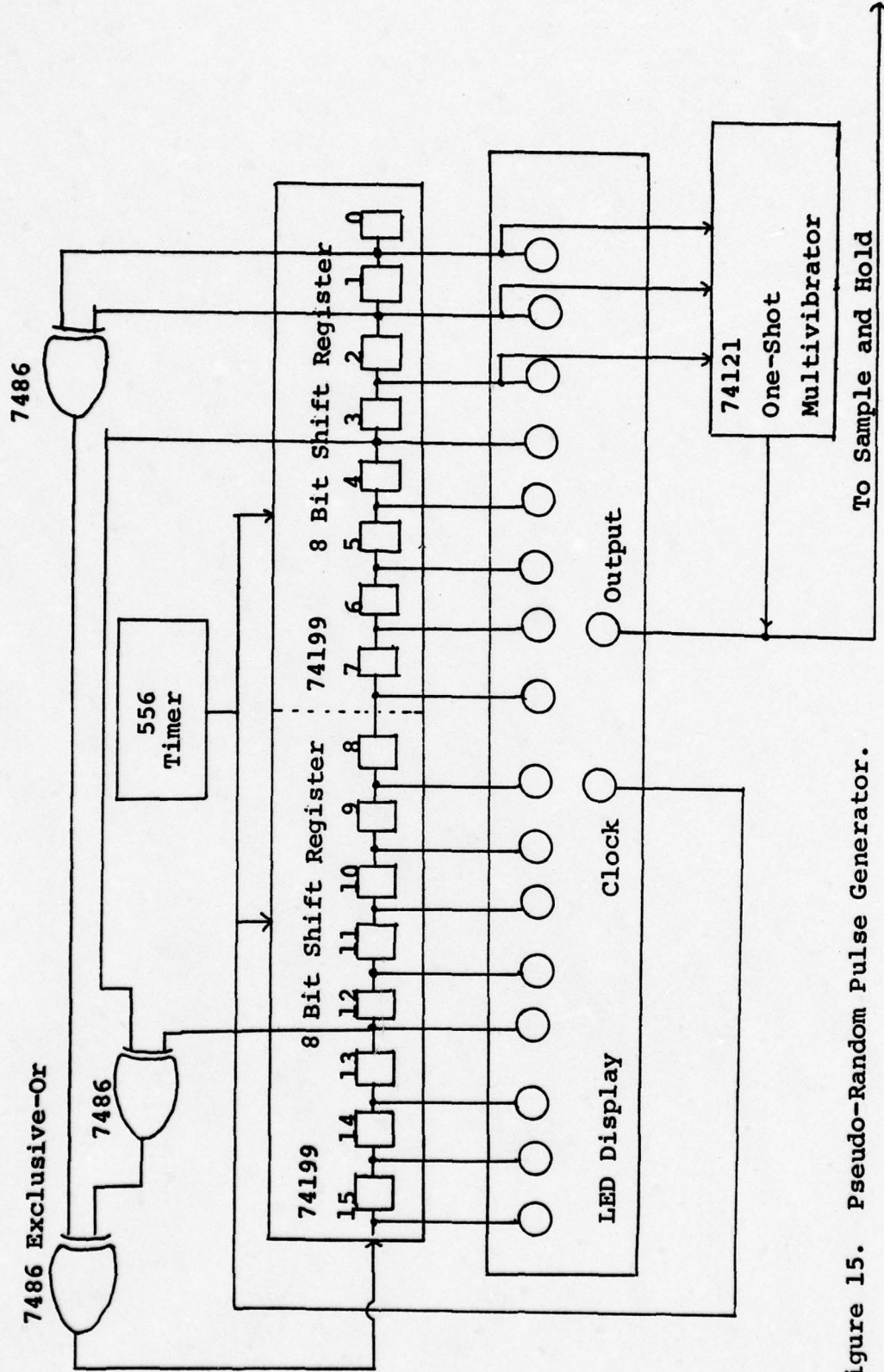

Figure 15. Pseudo-Random Pulse Generator.

a timer, two 8 bit shift registers, a monostable multivibrator, and an LED panel display.

The two 8 bit shift registers are operated serially to yield a sequence of logic states. The logic state of the last two registers, 1 and 0, are fed into an exclusive-or gate. The logic state of registers 3 and 12 are fed into another exclusive-or gate. The outputs of these exclusive-or gates are the inputs to the third exclusive-or gate which produces the input into register 15. The last three registers are fed into the one-shot monostable multivibrator to give a pseudo-random pulse.

The characteristic polynomial for this setup is $x^{16} + x^{12} + x^3 + x + 1 = 0$. This is an irreducible polynomial of degree 16, the period of which is $2^{16} - 1 = 65,535$. Thus, it will take 65,535 clock pulses before the sequence repeats itself.

The LED panel display shows the state of each shift register as well as the clock pulse and the occurrence of one-shot outputs.

E. SAMPLE AND HOLD

Two sample and hold networks were constructed [Fig. 16] by LT Allen Boutz using the example given by Marvel [Ref. 6]. One is for pitch and the other is for roll.

The operation of the circuit is described next. A strobe pulse from the one-shot multivibrator turns on the junction FET Q1. This completes the feedback loop of IC1

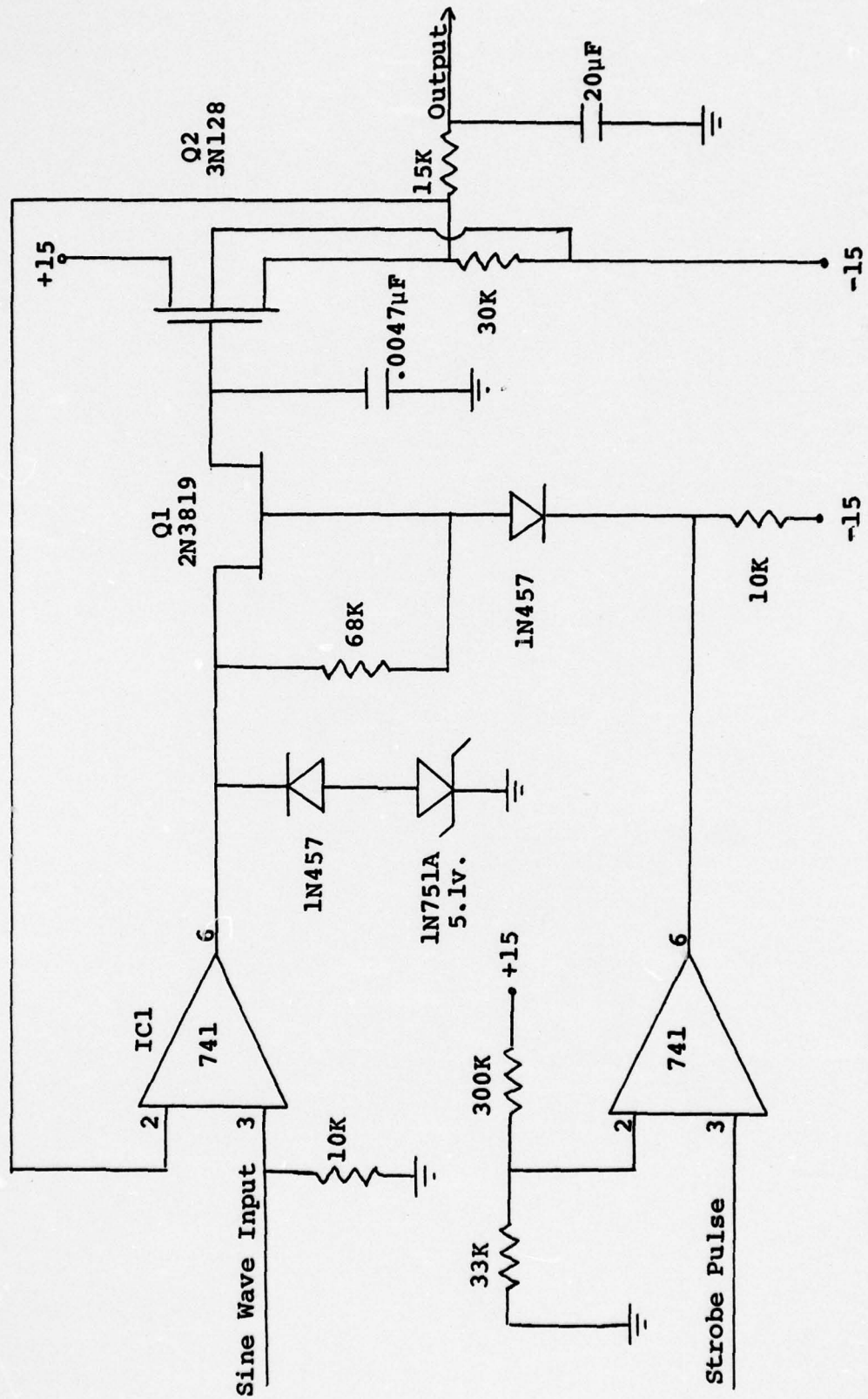

Figure 16. Sample and Hold.

(IC1, Q1, and Q2). An instantaneous sample of the sine wave input is then stored in the .0047 microfarad capacitor which charges during the time the strobe pulse is on. When the strobe pulse ends, the .0047 microfarad capacitor maintains its charge until the next random one-shot occurs.

The .0047 microfarad capacitor used in this circuit is a tantalum capacitor. The capacitor type is important because some capacitors do not retain the stored voltage, due to a polarization phenomenon which causes the stored voltage to decrease with a time constant of several seconds.

The sine wave input to the sample and hold networks are provided by two Wien bridge oscillators described in the next section.

F. WIEN BRIDGE OSCILLATORS

Two Wien bridge oscillators [Fig. 17] were constructed on the same circuit card as the two sample and hold networks. The frequency of oscillation is determined by the formula $f = 1/(2\pi RC)$. The amplitude of the circuit was stabilized by the introduction of a 2K thermistor whose resistance decreases with temperature.

Since a random output of combinations of horizontal and vertical deflections was desired, the two oscillators were chosen to oscillate at frequencies of 5 and 7 Hz. The addition of the operational amplifier was to modify the amplitude of the sine wave output if desired. The peak to peak output voltage was chosen to be 6 volts. This peak to peak voltage value was chosen because 5 volts

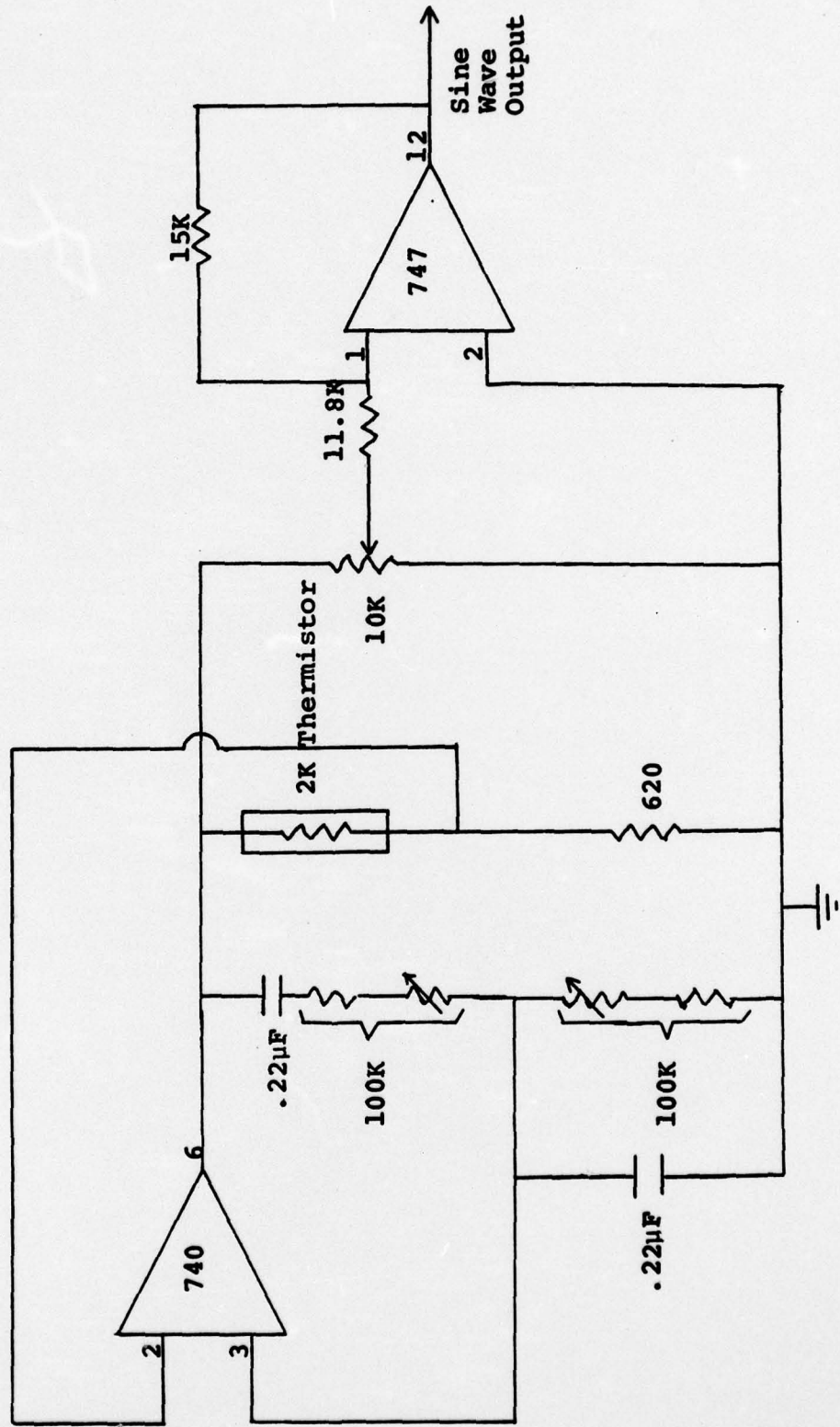

Figure 17. Wien Bridge Oscillator.

maximum can be put into the computer's A/D converter and the square root of the sum of two peak voltage samples squared (the radius) was then 4.24 volts. This radius measurement circuit is the subject of the next section.

G. RADIUS MEASUREMENT

By using two analog voltage multiplier integrated circuits (Burr-Brown 4204K's), a summing amplifier (μ A 740), and a multifunction converter (Burr-Brown 4301), a voltage equal to the square root of the sum of two input voltages squared is produced [Fig. 18]. Once again, since the input to the computer's A/D converter is limited to 5 volts, the output of this circuit has been previously limited by the random input circuit.

If the input voltage to one of the multipliers is equal to "X", then the multiplier's output voltage is equal to $X^2/10$. Likewise if the input to the other multiplier is "Y", then its output is equal to $Y^2/10$. The application of the operational amplifier is to sum its two inputs, so its output is equal to $(X^2 + Y^2)/10$. The multifunction converter is wired to produce an output voltage equal to ten times the square root of the input voltage. Thus the final output voltage is equal to $(X^2 + Y^2)^{1/2}$. The radius measurement circuit is extremely accurate and can operate well with any input which can be produced by the pitch and roll circuits.

The radius voltage measurement is converted to a digital value by the A/D converter in the computer. This

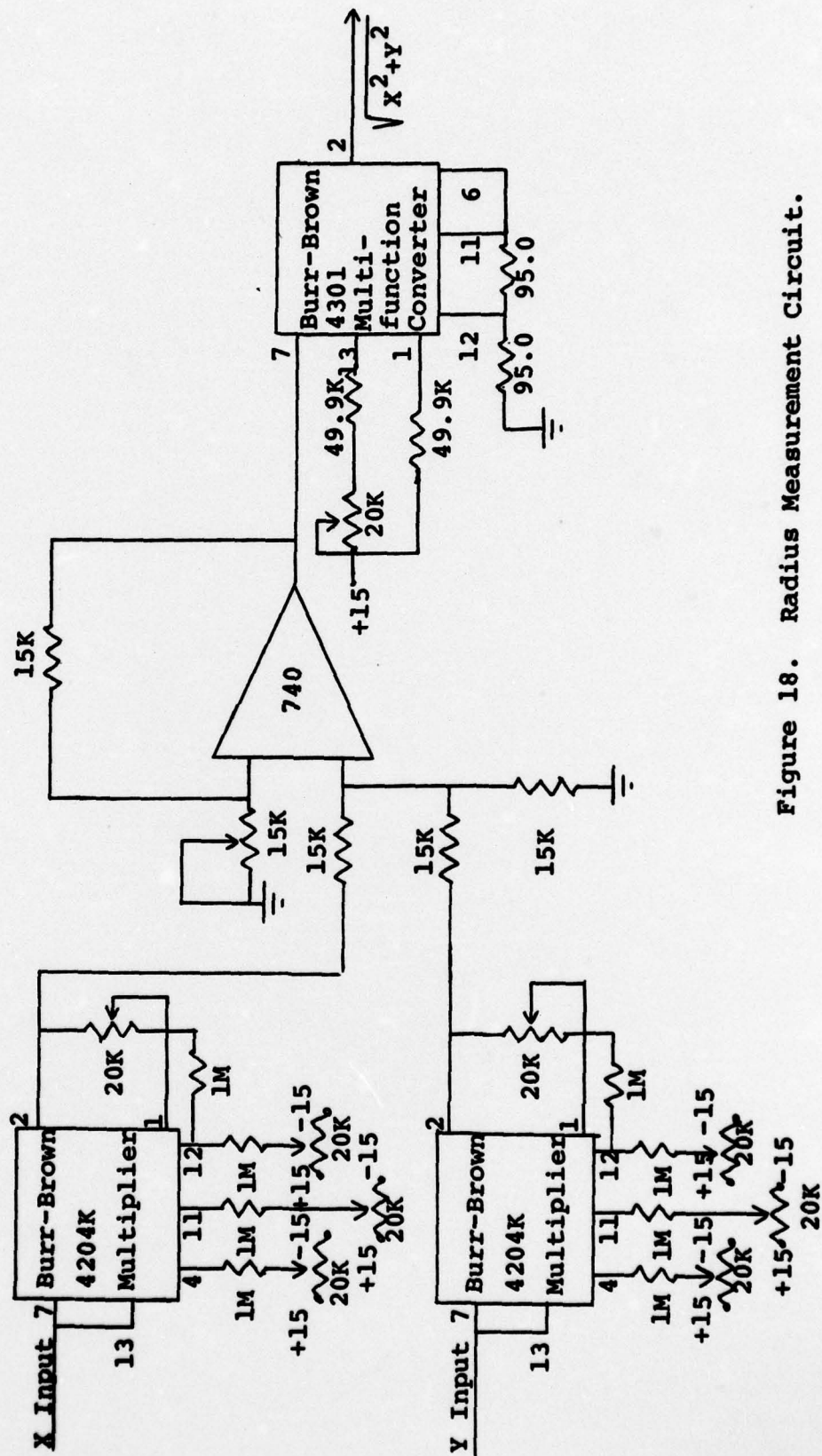

Figure 18. Radius Measurement Circuit.

digitized data may then be stored on the magnetic disc. The information on the disc is then readily available for analysis of the performance of the subject both with and without the biofeedback indicator.

H. BIOFEEDBACK CONTROL CIRCUIT

The biofeedback control circuit [Fig. 19] receives an input which is derived in the computer program TWODET.BFB and supplied through the computer's D/A converter. The output of the biofeedback control circuit is used to control the background light level in the screen room where a subject is being tested. The brightness of the light in the screened room is thus controlled by the voltage output of the computer. This, in turn, is controlled by the amount of waveform correlation between two closely spaced electrodes over the motor area of the cerebral cortex.

When no voltage is supplied by the D/A converter, the two transistors in the biofeedback control circuit are turned off and there is no current path from the light bulb to ground. Depending upon the amount of input voltage being supplied to the circuit by the D/A converter, the transistors will turn on and a corresponding amount of current will pass through the light bulb to ground.

I. PROGRAM DEVELOPMENT

1. TWODET.BFB

The computer program that processes and stores EEG data and gives a biofeedback output voltage is

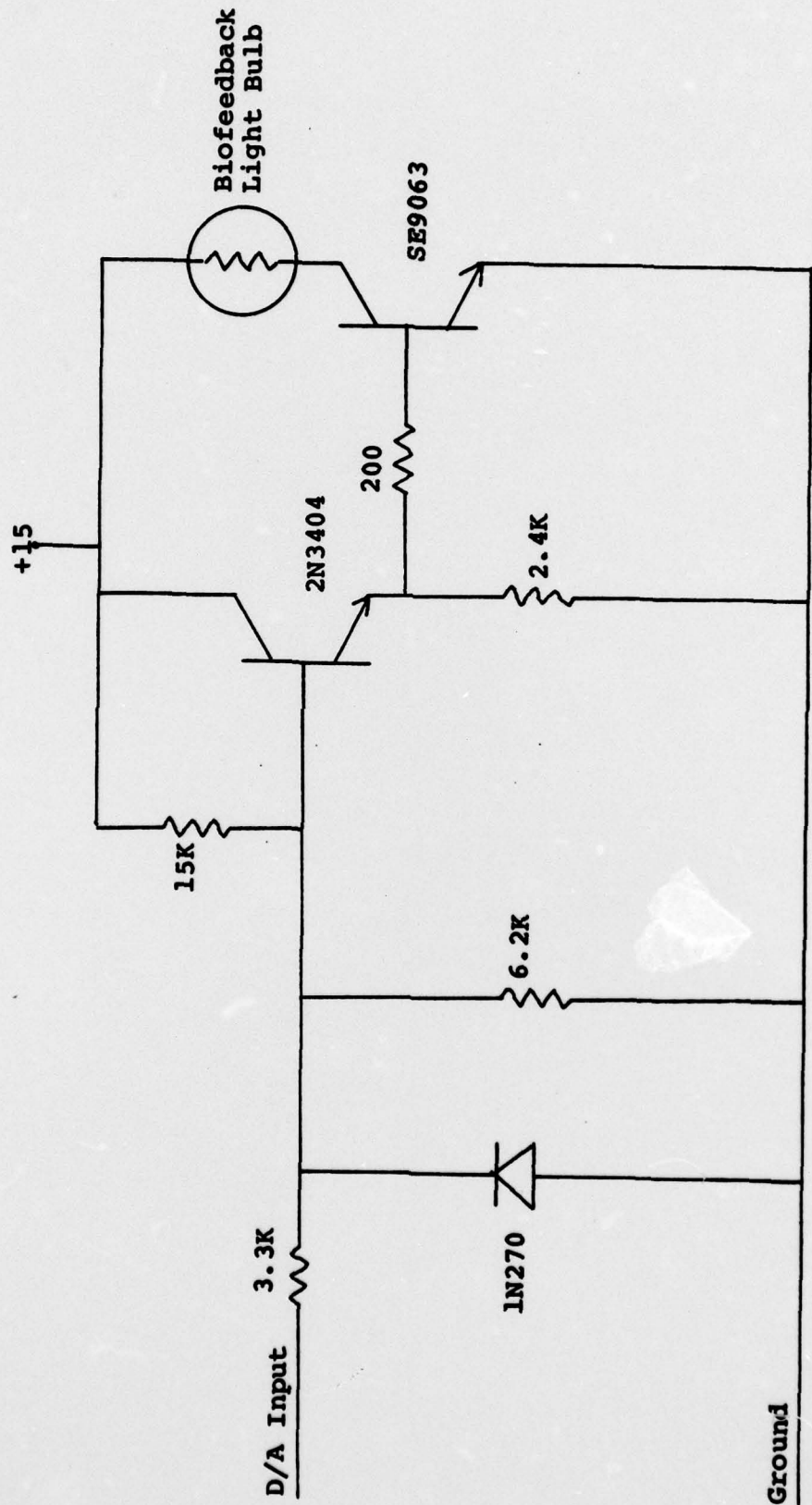

Figure 19. Biofeedback Control Circuit.

TWODET.BFB. TWODET.BFB has been edited from a previous version to include the display and storage of the output of the radius measurement circuit. The concept of TWODET.BFB is to cross-correlate two EEG electrode signals which have been band pass filtered. Prior to being bandpass filtered, seven electrode signals have been averaged and this average has been subtracted from the respective signals of two closely spaced electrodes. This is done in order to remove unwanted signals that are common to all seven electrodes. The amount of correlation is then fed back to the subject through a D/A converter to vary the intensity of a light bulb in the screen room. TWODET.BFB also stores data on a disk to be analyzed at a later date by another program. The data that is stored is the output of each of the two closely spaced electrodes, their cross-correlation, and the radius from center measurement. Each second of the above processed data is presented on the CRO display at the operators console. The biofeedback signal is updated every quarter of a second.

2. REPLAY.VAR

The program that is presently in use to analyze the data stored on the disk is REPLAY.VAR. This program allows the user to reexamine all the previously stored data on the storage oscilloscope. There may be 600 frames of data per run divided into six epochs of 100 frames each. The cross-correlation of each frame is integrated and then plotted. The mean and standard deviation for each epoch is computed and also displayed on the same plot.

An example of a plot made during an EEG run can be seen in Fig. 20. This plot was made on a subject with the TWODET bandpass filter set at 70 to 100 Hz. A description of the six epochs of Fig. 20 is as follows: In all epochs except D and E the subject was engaged in correcting pip position.

RUN A. Biofeedback light operating;
clock rate = 1.47 Hz.

RUN B. Biofeedback light operating;
clock rate = 1.47 Hz.

RUN C. Biofeedback light operating;
clock rate = 2.53 Hz.

RUN D. Biofeedback light operating;
subject involved in mental arithmetic.

RUN E. Biofeedback light operating;
subject relaxed, no task.

RUN F. Biofeedback light not operating;
clock rate = 2.53 Hz.

The subject reported that he could make the light get brighter when moving the "pip" back to the center of the oscilloscope. Upon reaching the center the light would dim. The brain had finished the assigned task and was waiting for another. The mental arithmetic proved to increase the biofeedback and the subject reported that the intensity of the light corresponded to the difficulty of the task he presented to himself.

J. FUTURE PROGRAM REQUIREMENTS

One objective of the computer analysis is to examine the results of a number of EEG runs under similar conditions and determine if there is a preferred frequency for performing

COPY AVAILABLE TO DDC DOES NOT
PERMIT FULLY LEGIBLE PRODUCTION

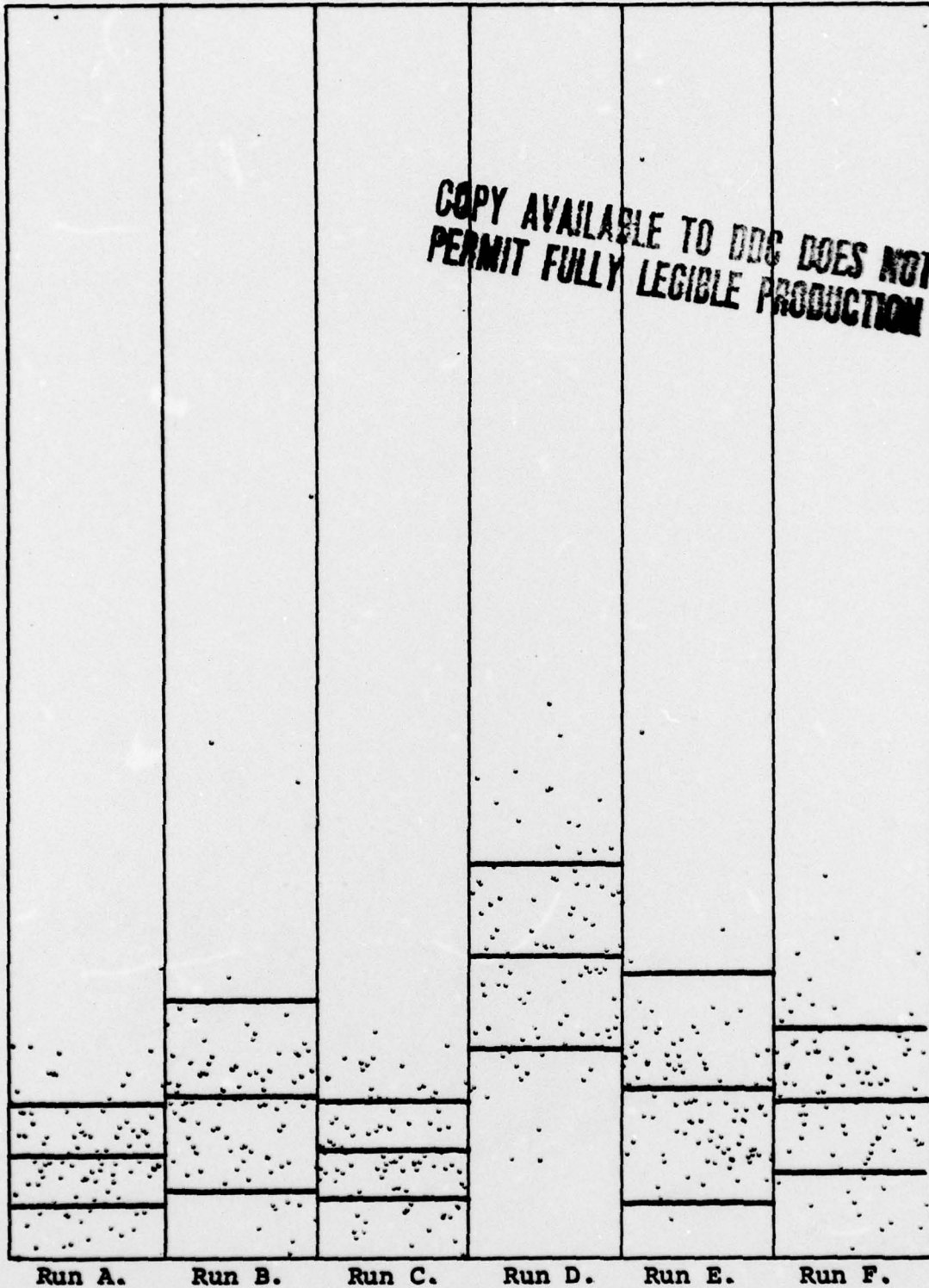

Run A. Run B. Run C. Run D. Run E. Run F.
The center lines represent the average and the top and bottom lines represent the standard deviation.

Figure 20. Integration of Cross Correlated EEG Data.

the task. If repeatable results can be obtained then one may say with a great amount of confidence that there are such things as preferred frequencies.

Another objective of the computer analysis is to determine what effect, if any, the biofeedback light has on the subject's task performance.

An analysis must be made of the stored data taken by the radius measurement circuit. This may be done in the following manner. Upon occurrence of a one-shot output, begin integrating the cross-correlation. Stop integrating when the radius measurement returns to a specified value above zero. Divide the value obtained by the amount of time elapsed between the occurrence of the output pulse and the specified minimum value. Store this result and continue this process for one epoch. Upon completing one epoch for one EEG run, average the stored results and compute the standard deviation.

Although this may have no initial meaning, over a number of runs and a number of subjects, it can be a statistically important relationship worthy of examination.

Another more simple method of analysis of the radius measurement circuit would be to find the amount of time that the radius was above a specified minimum value. When comparing epochs with the same clock rate the total number of random pulses for each epoch will be approximately equal for all epochs. Then the time above the specified value

for an epoch without feedback can be compared to the time above the specified value with feedback.

IV. SUMMARY AND CONCLUSIONS

The reason for building the tasking system was to enable a researcher to examine the higher frequency EEG's found when a subject is mentally alert and attentive to a task. The tasking system built proved itself to be extremely stable and reliable. The pitch and roll circuits gave the subject a task like a pilot would face in extremely rough weather conditions. The pseudo-random outputs which caused deflections on the oscilloscope appeared to be very random to the individual being tested. The tasking system effectively kept the subject alert and busy trying to keep the pip centered.

The results thus far indicate that the biofeedback system reinforces the idea that the amount of waveform correlation is related to the subject's amount of concentration. If analysis of the radius measurement circuit shows that when the waveform correlation is highest the subject performs a better job, then more research work in this area is warranted. If this happens to be the case then the following questions are raised:

1. Is there a distinct preferred frequency for every different type of task? If so, how many different preferred frequencies are there?
2. Is stress a factor in the amount of waveform correlation produced? By increasing the clock

rate of the pseudo-random pulse generator the task becomes extremely difficult and frustrating for the subject.

3. Is the fact that the two closely spaced electrodes were placed over the premotor area of the cerebral cortex important? What other areas of the cerebral cortex will produce the same frequencies? A thorough mapping should be done. The areas being used may not be the best ones available for the job.
4. Will the subject perform better after training? If so, how much training is necessary for the subject to reach his peak of effectiveness. It may be possible to identify one person who may be a better candidate for pilot training than another.

There is a lot of work still to be done before anyone will know the answers to any of the above questions. The tasking system will enable a subject to be tested sufficiently to do the EEG analysis work necessary to get a start at answering some of them.

LIST OF REFERENCES

1. Lindsley, Donald B. and Wicke, J. B., Bioelectric Recording Techniques, v. I-B, P. 3-79, ed. by Thompson, Richard F. and Patterson, Michael M., Academic Press, 1974.
2. Guyton, Aurthur C., Medical Physiology, p. 677-728, W.B. Saunders Company, Philadelphia, 1971.
3. Creutzfeldt, O.D., Legewie, H., and Simonova, O., "EEG Changes During Performance of Various Tasks Under Open- and Closed-Eyed Conditions," Electroencephalography and Clinical Neurophysiology, v. 27, p. 470-479, 1969.
4. Nowlic, David P. and Kamiya, J., "The Control of Electroencephalographic Alpha Rhythms Through Auditory Feedback and the Associated Mental Activity," Biofeedback and Self-Control, v. 1, p. 283-291, 1971.
5. Naval Postgraduate School, NPS-57LN70071A, A Simulator Evaluation of Pilot Performance and Acceptance of An Aircraft Rigid Cockpit Control System, by Donald M. Layton, p. 20, July 1970.
6. Marvel, D.C., A Versatile System for Interfacing Subject to Task in EEG Analysis with Biofeedback, Master's Thesis, Naval Postgraduate School, 1975.

INITIAL DISTRIBUTION LIST

	No. Copies
1. Defense Documentation Center Cameron Station Alexandria, Virginia 22314	2
2. Library, Code 0212 Naval Postgraduate School Monterey, California 93940	2
3. Department Chairman, Code 62 Department of Electrical Engineering Naval Postgraduate School Monterey, California 93940	1
4. Professor George Marmont, Code 62Ma Department of Electrical Engineering Naval Postgraduate School Monterey, California 93940	10
5. LT Douglas Pierce Ayers USN 1636 St. Marie Court Virginia Beach, Virginia 23462	1