

AD-A035 893

NAVY UNDERWATER SOUND LAB NEW LONDON CONN  
ECAP: A DESIGN REVIEW TOOL.(U)  
JUN 67 A A FILIPPINI

F/G 9/3

UNCLASSIFIED

USL-TM-2134.4-597-67

NL

1 of 1  
ADA035893



END

DATE  
FILMED  
3-77

001743  
ADA035893

21344-597-67

001743  
sp 6

MOST Project - 9

COPY NO. 1  
COPY TO NAVAL SHIPS  
PMS-87  
USL Problem No.  
1-654-00-00

COPY AVAILABLE TO DDC DOES NOT  
PERMIT FULLY LEGIBLE PRODUCTION

U. S. Navy Underwater Sound Laboratory  
Fort Trumbull, New London, Connecticut

⑥ ECAP: A DESIGN REVIEW TOOL.  
by  
⑨ ⑩ Alfred A. Filippini ⑭  
USL-TRM  
USL Technical Memorandum No. 2134.4-597-67  
⑪ 8 June 1967 ⑫ 6pp.

DDC  
FEB 23 1977  
A

INTRODUCTION

This memorandum is written to: inform Laboratory personnel that ECAP, a general purpose electronic circuit analysis program, is available for their use; describe this program; and provide instructions concerning its use. Section I is a general explanation of the function of the program, Section II contains a description of the software with which the ECAP user must be familiar, and the step-by-step computing procedure is detailed in Section III. Wherever possible in Section III, examples rather than lengthy discussions are used to demonstrate proper procedure.

No attempt has been made to duplicate completely the information in the ECAP Operators Manuals references (a), (b), and (c). Instead, an attempt has been made to present sufficient information to permit the reader to program circuit analyses after reading this document. When specific problems arise, however, the Operators Manuals should be consulted.

SECTION I: PROGRAM DESCRIPTION

The Electronic Circuit Analysis Program (ECAP) is a general purpose program which allows USL engineers to utilize the computer facilities at the Laboratory to analyze electronic circuits. The International Business Machines Corporation and the Norden Division of United Aircraft Corporation jointly developed ECAP, and TRW Systems converted it for use on USL's IBM 704 computer.

ECAP is really a combination of three analysis programs:

- (1) a DC Analysis Program,
- (2) an AC Analysis Program, and
- (3) a Transient Analysis Program

DISTRIBUTION STATEMENT A  
Approved for public release;  
Distribution Unlimited

For the DC Analysis Program the circuit must be described using ENCL (1) to USL/USN LTR No. 2134.4-597 of August, 1967

254200 LB

resistors, independent voltage sources, dependent current sources, and independent current sources. The computer will calculate and print out all the voltages and currents, power dissipation, worst case voltages, sensitivities, and standard deviations if so directed by program control cards. In addition, certain intermediate results such as current, impedance, and admittance matrices will be printed out if requested by the engineer. The circuit parameters may be modified, permitting the engineer to study the effects of component variations on circuit performance.

Only resistors, capacitors, inductors (including mutual inductors), independent voltage sources, independent current sources, and dependent current sources can be used to describe a circuit for an AC analysis. This program will compute and print out at a single frequency all voltages, currents, element power dissipations, current matrices and admittance matrices if so desired. As with the DC Analysis Program the circuit parameters (including frequency) may be varied.

The Transient Analysis Program requires that the circuit be modeled with resistors, capacitors, inductors; DC independent and time-varying independent voltage sources; DC independent, time-varying independent and dependent current sources; and logical switches. Circuit parameters can be automatically altered when branch currents reverse direction through the use of the Logical Switch. With the Transient Analysis Program all node voltages and element currents are printed out as a function of time.

ECAP is a very useful design review tool. The DC Analysis Program can be used to evaluate DC bias currents and voltage; determine stress ratios; perform worst case, statistical, or sensitivity analysis of circuits. A frequency analysis can be conducted by use of the AC Analysis Program to obtain open-loop frequency response data. With the Transient Analysis Program and piece-wise linear models of non-linear devices, actual circuit performance as a function of time can be duplicated. As a result, biasing of circuits involving non-linear devices can be studied, the step response of a circuit can be analyzed, rise and fall times can be measured and the output of a non-linear circuit for various combinations of inputs can be computed using the Transient Analysis Program.

## SECTION II: PROGRAMMING SOFTWARE

The USN/USL ECAP user must familiarize himself with only two printed forms. They are the Compilation/ Check-Out/ Production Request and the Fortran Coding Form and Data sheet. Both are available in the USL Computing Center.

The Compilation/ Check-Out/ Production Requests properly completed for each type of analysis, are shown in figures 1, 2, and 3. Because the request form is returned to the ECAP user following the execution of each analysis, the request is filled-in only once for each type of analysis. The information for items 1, 2, 4, and 5 is unique to each ECAP User; the other items on the form need not be altered.

2  
*Letter on file*  
A

Figure 4 is a Fortran Coding Form and Data Sheet. The information in the heading is self-explanatory and the body of the form is used to describe the punched cards required by the ECAP user.

The punched cards necessary to utilize ECAP are grouped into six categories:

- (1) Time Cards,
- (2) Comment Cards,
- (3) Command Cards,
- (4) Data Cards,
- (5) Solution Control Cards, and
- (6) Output Specification Cards.

Computer Center Personnel punch the Time Card (see figure 5) from the Compilation/ Check-Out/ Production Request. When submitted with the program deck, it will be retained by the Computer Operator.

Comment Cards are characterized by a C in column 1 and a message in the data field which extends from column 7 to column 72. These cards serve no useful programming function; the message is simply reproduced on the output data sheet. Cards with only a C in column 1 cause line spaces in the print-out.

Each analysis program deck should begin with Comment Cards which identify the output data. The format for these Identification Cards has been established by the author and has proved useful to the author and computer center personnel.

Three identification cards are used:

- (1) A Program Description Card,
- (2) A Circuit Description Card, and
- (3) A Date Card.

The information for these cards is demonstrated in figure 6. The first card identifies the program, the computer, the program user, his code, and his extension. The circuit Description Card identifies the circuit being analyzed and the third card identifies the run number, and date.

There are five cards in the Category Command Cards. They are:

- (1) AC Analysis,
- (2) DC Analysis,
- (3) Transient Analysis,
- (4) Execute, and
- (5) Modify Cards.

The data for these cards is shown in figure 7. Only one Analysis

Card is used per program deck. Modify cards may only be used with the AC and DC Analysis Programs. An Execute Card is paired with the Analysis Card and every Modify Card.

There are five types of Data Cards:

- (1) B-Cards,
- (2) T-Cards,
- (3) M-Cards,
- (4) S-Cards, and
- (5) Source Cards.

The Standard Branch written into ECAP is shown in figure 8. The directions of positive currents and the polarities of positive voltages are shown on the figure. Reversed directions and polarities must be indicated by negative values on the Data Cards.

The B-Card is used to describe the initial and final nodes, the linear element, the time-invariant independent voltage source, the time-invariant independent current source, and initial conditions. Figure 9 demonstrates the relationship between the B-Card and the Standard Branch.

The Branch number is written in columns 1 through 5 of the data card and the remainder of the data must appear in columns 7 through 72. The node numbers are put on the data card in sequence, the initial node first. Therefore, the directions of positive currents and the polarities of positive voltages are established by the users selection of the initial node. Ground nodes are assigned the number 0. Following the node numbers the parameter values appear separated by commas. Initial conditions (i.e., voltage across capacitors and currents through inductors at the initial time of a Transient Analysis) are established by EO and IO statements. Note that any Fortran coding of numbers is acceptable to describe parameter values. For those not familiar with the coding of scientific notation,  $1.2 \times 10^3$  is written in Fortran 1.2 E3.

The T-Card describes the dependent current source in each branch. Like the B-Card, Columns 1 through 5 are used only for the number of the dependent source. The control and source branch numbers, in that order, and the current gain which relates the element current of the control branch to the source current appear in the data field. Examples of the use of the T-Card may be found in figure 10.

The mutual inductance between two branches containing inductors is described by the M-Card. The format of this card is similar to that of the T-Card. However, the order of the branch numbers is unimportant. The application of M-Cards is demonstrated in figure 11.

The logical switch operation is controlled by the S-Card. Like the other cards discussed so far, the S-Card number is put in columns

1 through 5. The element current of a branch is sensed and when that current is zero or negative, the switch is off; when the current is positive, the switch is on. As the state of the switch changes, the values of circuit parameters may be changed. Look at the Fortran statement for the S-Card in figure 12. The S-Card causes the element current of branch 2 to be sensed. When the current changes, branches 2, 3, and 4 will be affected. Initially the state of the switch is off (i.e., the current in branch 2 is zero or negative). With S1 in the off state, the resistance of branch 2 is 500, the capacitance of branch 3 is 2 $\mu$ f, and the beta of the dependent current source is 100. When S1 goes on (i.e., branch 2 current goes positive), the resistance of branch 2 goes to 550 $\Omega$ , the capacitance of branch 3 goes to 3 $\mu$ f, and the beta of T1 goes to 125. Note that the beta of T1 is altered by having the switch action affect branch 4 (the control branch), not branch 1 (the source branch). Should the current return to zero or go negative, the parameters would return to their initial values.

To describe time-varying independent voltage and current sources, three types of Source Cards are used:

- (1) Non-Periodic,
- (2) Periodic, and
- (3) Sinusoidal.

The Non-Periodic Source Card data is shown on line 2 of figure 13. Columns 1 through 5 of the card define the type of source (current or voltage) and the number of the branch in which it is positioned. In the data field, the number of time steps between changes in source values appears in parentheses, and the voltages or currents at each increment of time beginning at start time appear separated by commas. The Time Step on line 3 indicates the interval at which circuit performance is computed. A linear change in amplitude between time increments is assumed and the value of the final entry is maintained until final time is reached. The number of voltage entries is limited to 126.

Figure 14 demonstrates a Periodic Source Card. Except for the addition of a P in the data field to designate a periodic function, the data entries are identical to those of the Non-Periodic Source Card. The first and last value of voltage or current should be equal because the function is periodic. As for the Non-Periodic source the maximum number of entries is 126.

A Sinusoidal Source Card is described in figure 15. Columns 1 through 5 are used to describe the type of source and branch number as with the Non-Periodic and Periodic Source Cards. In the data field, however, SIN is used to indicate that a sinusoidal source is desired and the period in seconds is put in parentheses. The peak value, the DC average value, and the initial time shift follow, separated by commas.

For an AC Analysis, B-Cards, T-Cards, and M-Cards; for a DC Analysis, only B-Cards and T-Cards; and for a Transient Analysis, B-Cards, T-Cards, S-Cards, and Source Cards are used.

Continuation Cards may be used if the data is in excess of the data field of one card. A Continuation Card is characterized by an asteric in column 6. The data field of the Continuation Card can then be considered an extension of the previous Data Card.

The number of Data Cards is limited to:

200 B-Cards (limited to 50 inductors if M-Cards are used)  
200 T-Cards, and  
200 S-Cards.

In addition, the circuit must contain no more than 50 nodes.

The data cards used with Modify-Execute Card pairs have a modified format. First, the data field of the card need only describe the parameter to be changed. Second, multiple variations of a parameter may be written into one statement which defines the initial value, the number of steps (in parentheses), and the final value. Examples of these Data Cards can be found in figure 16. No more than 50 parameter changes in one parameter modification are allowed.

Solution Control cards are unique to the type of Analysis being performed. Figures 17, 18, and 19 lists the Fortran statements for Solution Control Cards.

If the AC Analysis Program is being used there is only one Solution Control Card and this card must appear in the program card deck to specify frequency. When the Frequency Card is used to control the initial computation, only one value of frequency may be specified. When the Frequency Card is used with a Modify-Execute Card Pair, a single value, and arithmetic progression, or a geometric progression may be specified. See figure 17. For an arithmetic progression the initial value, the number of evenly spaced steps, and the final value are written. The number of steps must appear in parentheses with a plus sign. For a geometric progression, the ratio is specified in parentheses instead of the number of steps. The lack of a plus sign indicates a geometric progression.

Three Solution Control Cards may be used if a DC Analysis Program is in use. If the Sensitivity Card appears in the card deck, the partials and sensitivities of each node voltage with respect to each resistance, beta, and source value is computed and printed out. If the Worst Case Card appears in the deck, the worst case minimum, worst case maximum, and nominal node voltages for each node specified

on the Worst Case Card are printed out. If no node numbers are written all node voltages will be printed out. For this computation the minimum and maximum values or the tolerances, in addition to the nominal parameter values, must be specified. See figures 9 and 10 for examples of how to specify the extremal values. The Standard Deviation Card causes the standard deviation of each node voltage to be printed out. For this computation, the  $\pm 3$  standard deviation values of the circuit parameters are specified with the same format that the minimum and maximum values are specified for a Worst Case Analysis.

When the Transient Analysis is being run, ten Solution Control Cards may be used. See figure 19. The Time Step Card must appear in every transient analysis. However, if any of the other 9 cards are omitted, the values listed in figure 20 are assumed. The Output Interval Card specifies the number of Time Steps between data print-outs. When the Equilibrium Card is entered in the card deck, a solution is obtained with the inductors in the circuit replaced by short circuits and capacitors by open circuits. The values of open and short circuits are specified with the appropriate Solution Control Cards. The 1-ERROR, 2-ERROR, and 3-ERROR Cards control the acceptable magnitude of the sum of the nodal current unbalances, the accuracy of the switch accutation time printed out, and the value of the time steps immediately after an initial condition solution. Reference (a) should be consulted if it is desired to use these ERROR cards.

The Output Specification Cards allow control by the ECAP User of the data printed out. See figure 21.

For the AC and DC Analysis Programs:

- (1) node voltages (NV) (VOLTAGES),
- (2) element voltages (CV),
- (3) branch voltages (BV),
- (4) element currents (CA),
- (5) branch currents (BA),
- (6) element power dissipation (BP), and
- (7) miscellaneous outputs (MI) (MISCELLANEOUS)

can be printed out. The various voltages and currents are designated on the diagram of the Standard Branch (figure 8). Element power is the product of element voltage and element current. Miscellaneous outputs are current and impedance matrices for AC Analyses; and admittance, current, and impedance matrices for DC Analyses.

For the Transient Analysis Program, the only data permitted to be printed out is:

- (1) node voltages (NV) (VOLTAGES) and
- (2) element currents (CA) (CURRENTS).

### SECTION III: COMPUTING PROCEDURE

The author recommends the computing procedure established in this section of the memorandum. Although other procedures will work as well, the author has demonstrated that delays and errors are minimized by following the steps outlined here.

To demonstrate the suggested computing procedure, the bias, frequency response, and response to a square wave of the circuit diagramed in figure 22 will be determined. The DC circuit will be subjected to a Transient Analysis to determine bias conditions; the worst case bias conditions will be determined using the DC Analysis Program once the nominal bias conditions have been established; the frequency analysis will be performed on the circuit with the AC Analysis Program; and finally, the Transient Analysis Program will be used to determine the step response of the circuit.

Figure 23 is the ECAP DC Circuit Diagram. This diagram is drawn directly from the Standard Circuit Diagram (figure 22) and differs very little from a standard dc equivalent circuit. Note, however, that care has been taken to arrange the circuit elements such that a Standard Branch (figure 8) appears between every pair of nodes, to indicate the direction of element currents, and to number the nodes and branches using consecutive numbers. Ground nodes are numbered 0.

Models for non-linear devices should be carefully selected. There is no one model which meets all applications. This is especially true of transient models. The author urges each ECAP user to select a model which duplicates with sufficient accuracy the parameters which have the greatest effect on the particular outputs desired. The models in figures 24 and 25 were carefully chosen to be only as sophisticated as they need be. Because they duplicate the  $V_{BE}$ - $I_B$  and  $V_{CE}$ - $I_C$  characteristics of the 2N930 type transistor with sufficient accuracy to determine the bias points, the complex models in figure 24 were selected. However, the simple models diagramed in figure 25 adequately represent the  $V$ - $I$  characteristics once the nominal bias points have been determined. The values of the parameters (voltage and resistance) in branches 9 and 11 are based on the results of the analysis using the models in figure 24.

To document the ECAP Data, a Compilation/ Check-Out/ Production Coding Form and Data Sheets must be filled in. Figures 26 and 27 show the Fortran sheets completed for the Transient Analysis of the DC Circuit. Note the difference between the letter  $\emptyset$  and the number 0, the letter I and the number 1.

To expedite the computation, the computer center personnel are assisted by the ECAP user. The completed forms are brought to the

Card Punch Operators' Room where they are date-stamped and left. The ECAP User is called when the cards have been punched and verified. Usually, this takes one day. When the user is called, he returns to the Card Punch Room to receive his original forms plus the punched cards. The cards are then assembled in the proper order:

- (1) Time Card
- (2) Identification (Comment) Cards,
- (3) Analysis (Command) Card,
- (4) Data Cards,
- (5) Solution Control Cards,
- (6) Output Specification Card,
- (7) Execute (Command) Card,

The cards are then submitted to the Computer Room with the Compilation/Check-Out/ Production Request in front of the deck under the elastic band. The Production Log is filled-in as shown in figure 28 and the card deck is put in the "Production" box located in the Computer Center. The output data will usually be available in 4 hours.

The output data for the Transient Analysis of the DC Circuit may be found in Appendix A. The voltages are recorded on the ECAP DC Circuit Diagram in figure 23.

Once the bias points have been determined, the dc transistor models shown in figure 25 result and a Worst Case DC Analysis can be run.

Once again a Request Form (figure 2) and a Coding Form (figure 29) are completed and submitted to the Key Punch Operators, When the punched cards are returned, appropriate cards from the Bias Point Analysis are used to assemble a deck which results in the statements appearing on page B-1 of Appendix B. A check should be made to insure that the cards are in the proper order. The extra cards required for data modifications are put in the following order:

- (1) Modification (Command) Card,
- (2) Data Cards, and
- (3) Execute (Command) Card.

The dc output data appears in Appendix B.

Knowing the bias points, the ECAP AC Circuit Diagram (figure 30) and the Transistor Model Diagrams (figure 31) are drawn. An AC Analysis Request Form (figure 1) is completed and the circuit data is transferred to the Coding Forms. Modification of AC Analysis data require that the extra cards be put in the following order:

- (1) Modification (Command) Card,
- (2) Data Cards,

- (3) Frequency (Solution Control) Card, and
- (4) Execute (Command) Card.

The input data statements and the output data appear in Appendix C. The output data is plotted in figure 32.

To determine the response to a step input function, a transient analysis was run. The Transient Circuit Diagram and Transistor Models are shown in figures 33 and 34 respectively. The input step is shown in figure 35. The input and output data are recorded in Appendix D. The output response data is plotted in figure 36. It should be noted that the initial voltage across each capacitor is specified in the input data. In addition, it should be noted that it was necessary to exclude from the transient analysis the 60 microfarad capacitor in the power supply isolation network. Until this was done the accuracy of the current computations at node 5 was inadequate.

#### SUMMARY

This memo was written to introduce the Electronic Circuit Analysis Program to the reader. The author in no way pretends that this memo thoroughly covers the use of ECAP. On the other hand, it is hoped that after reading this memo, most engineers will be able to utilize the available computational tool without reading the IBM ECAP Users Manual (Reference (a) ). However, if and when problems arise, or when additional information is needed, the appropriate reference or references listed in this memo should be consulted.

ECAP is a complex analysis program, especially useful as a design review tool. Breadboarding can be minimized or eliminated with proper use of this program.

*Alfred A. Filippini*  
ALFRED A. FILIPPINI  
Electronic Engineer

LIST OF REFERENCES

- (a) "1620 Electronic Circuit Analysis Program (ECAP) (1620-EE-02X) User's Manual," IBM Application Program, H20-0170-1, International Business Machines Corporation, New York, 1965, 188 pages.
- (b) "Electronic Circuit Analysis Program (ECAP) for IBM 704 at USN/USL." 7423-6007-TO-000, TRW Systems, California, 6 December 1965, Contract No. NOW-65-0195-d, 119 pages.
- (c) "7090/7094 ECAP," International Business Machines Corporation, New York, 18 pages.
- (d) "1620 Electronic Circuit Analysis Program ECAP) (1620-EE-02x) Operator's Manual," IBM Application Program, H20-0171-0, International Business Machines Corporation, New York, 45 pages.
- (e) Professor Cyrus O. Harbort, University of Texas, "Solid State Models for Computing," Computer Aided Solid State Circuit Design, Design Engineering Institutes, University of Wisconsin, 3-4 May 1966, 27 pages.
- (f) Randall W. Jensen, "Charge Control Transistor Model for the IBM Electronic Circuit Analysis Program," PUB-157, Hughes Aircraft Company, California, 27 December 1965, 46 pages.
- (g) Arnold S. Spitalny, "Electronic Circuit Analysis," Norden Division of United Aircraft Corporation, Connecticut, 4 April 1966, 3 pages.
- (h) "Non-Linear DC Analysis User's Manual," D36-R-0096, Norden Division of United Aircraft Corporation, Connecticut, 17 February 1966, 41 pages.
- (i) Alfred A. Filippini, "Report of Travel to the University of Wisconsin Engineering Institutes Computer Aided Solid State Circuit Design Conference," 3-4 May 1966, USL Memo Ser 934.4-564, 12 July 1966, 3 pages.
- (j) A. Filippini to Code 907, "Typical Computational Needs of the ASW Electronic Design Review Group," USL Memo Ser 934.4-523, 14 October 1965, 9 pages.
- (k) Henry Weinberg, "Circuit Analysis Program," USL Tech. Memo No. 907-148-65, 28 October 1965, 27 pages.
- (l) D. G. Mark and L. H. Stember Jr., "Variability Analysis," Science and Engineering Series No. 79, Electro-Technology, July 1965, Volume 76, Number 1, page 35, 12 pages.
- (m) F. F. Kuo, "Network Analysis by Digital Computer," Proceedings of the IEEE, June 1966, Volume 54, Number 6, page 820, 10 pages.

**CHECK-OUT/PRODUCTION REQUEST**  
3ND USNUSL-364B (REV. 7/66)

HRS. —  
MIN. 20

To Be Called

11. Estimate

A. Check-Out (2)

(CHECK APPROPRIATE BOXES)  
(COMPLETE ITEMS 1 THRU 11)

B. Production (3)

1. Requestor A. FILIPPINI      2. Tel. Ext. No. 470      3. Coded Job No. 0678  
4. Job Order No. 1-654-00-00      5. Organization Code 2134.4  
6. Open Shop       7. Fortran       8. Components Used      a. Reader       c. Mag. Drum   
(or)      (or)  
Closed Shop       S.A.P.       b. Printer       d. Punch

(Fold)

9. Sense Switches used:  
All assumed up unless checked.

SS 1.	SS 2.	SS 3.	SS 4.	SS 5.	SS 6.
-------	-------	-------	-------	-------	-------

10.

Unit No.	In-put	Out-put	WRITE TAPE IDENTIFICATION	CHECK APPROPRIATE BOXES						
				Save	Punch	Plot	Pool	List		
1			SYSTEM							1
2	X		AC ANALYSIS PROGRAM							2
3	X		INPUT CARDS							3
4		X	OUTPUT TAPE						X	4
5										5
6										6
7										7
8										8
9										9
0										0

(Fold)

B.C.D.  BINARY  GAPLESS  INPUT TAPE MODE OUTPUT BINARY  B.C.D.

Program Stops and Procedures: HPR 5,0 = Correct Halt      HPR 6,0 = Bad ID Halt

NORMAL STOP HPR (0,1)

Special Instructions: BINARY TAPES IN HONEYWELL CABINET.

FIGURE 1: AC ANALYSIS REQUEST

**CHECK-OUT/PRODUCTION REQUEST**  
3ND USNUSL-364B (REV. 7/66)

HRS. —  
MIN. 5

To Be Called

11. Estimate

A. Check-Out (2)  (CHECK APPROPRIATE BOXES)  
(COMPLETE ITEMS 1 THRU 11) B. Production (3)

1. Requestor A. FILIPPINI 2. Tel. Ext. No. 470 3. Coded Job No. 0679  
4. Job Order No. 1-654-00-00 5. Organization Code 2134.4  
6. Open Shop  7. Fortran  8. Components Used a. Reader  c. Mag. Drum   
(or) (or) b. Printer  d. Punch   
Closed Shop  S.A.P.

(Fold)

9. Sense Switches used:  
All assumed up unless checked.

SS 1.	SS 2.	SS 3.	SS 4.	SS 5.	SS 6.

10.

Unit No.	In-put	Out-put	WRITE TAPE IDENTIFICATION	CHECK APPROPRIATE BOXES						
				Save	Punch	Plot	Pool	List		
1			SYSTEM							1
2	X		DC ANALYSIS PROGRAM							2
3	X		INPUT CARDS							3
4		X	OUTPUT TAPE						X	4
5										5
6										6
7										7
8										8
9										9
0										0

(Fold)

B.C.D.  BINARY  GAPLESS  INPUT TAPE MODE OUTPUT BINARY  B.C.D.

Program Stops and Procedures: HPR 5,0 = Correct Halt HPR 6,0 = Bad ID Halt

NORMAL STOP HPR (0, 1)

Special Instructions: BINARY TAPES IN HONEYWELL CABINET.

FIGURE 2: DC ANALYSIS REQUEST

CHECK-OUT/PRODUCTION REQUEST

3ND USNUSL 364B (REV. 7/66)

To Be Called

11. Estimate 

HRS.	-
MIN.	30

A. Check-Out (2)  (CHECK APPROPRIATE BOXES) (COMPLETE ITEMS 1 THRU 11) B. Production (3)

1. Requestor A. FILIPPINI 2. Tel. Ext. No. 470 3. Coded Job No. 0680  
 4. Job Order No. 1-654-00-00 5. Organization Code 2134.4  
 6. Open Shop  7. Fortran  8. Components Used a. Reader  c. Mag. Drum   
 (or) Closed Shop  (or) S.A.P.  b. Printer  d. Punch

(Fold)

9. Sense Switches used: All assumed up unless checked.

SS 1.	SS 2.	SS 3.	SS 4.	SS 5.	SS 6.
-------	-------	-------	-------	-------	-------

10.

Unit No.	In-put	Out-put	WRITE TAPE IDENTIFICATION	CHECK APPROPRIATE BOXES						
				Save	Punch	Plot	Pool	List		
1			SYSTEM							1
2	X		TRANSIENT ANALYSIS PROGRAM							2
3	X		INPUT CARDS							3
4		X	OUTPUT TAPE						X	4
5										5
6										6
7										7
8										8
(Fold)										
9										9
0										0

B.C.D.  BINARY  GAPLESS  INPUT TAPE MODE OUTPUT BINARY  B.C.D.

Program Stops and Procedures: HPR 5,0 = Correct Halt HPR 6,0 = Bad ID Halt  
NORMAL STOP HPR(0,1)

Special Instructions: BINARY TAPES IN HONEYWELL CABINET.

FIGURE 3: TRANSIENT ANALYSIS REQUEST

FORTRAN CODING FORM AND DATA SHEET

INDUSTRIAL-283

PREPARED BY A. FILIPPINI 2134.4

DATE 11 JANUARY 1967

TITLE ECAP

(NAME AND CODE NO.)

JOB ORDER NO. 1-654-00-00

TRANSIENT

PHONE EXT. 470 PROBLEM NO. 0680

PAGE 1 OF 1

ANALYSIS

STATEMENT NUMBER	IDENTIFICATION
1	
2	
3	
4	
5	
6	
7	
8	
9	
10	
11	
12	
13	
14	
15	
16	
17	
18	
19	
20	
21	
22	
23	
24	
25	

FORTRAN STATEMENT

7 8 9 10 11 12 13 14 15 16 17 18 19 20 21 22 23 24 25 26 27 28 29 30 31 32 33 34 35 36 37 38 39 40 41 42 43 44 45 46 47 48 49 50 51 52 53 54 55 56 57 58 59 60 61 62 63 64 65 66 67 68 69 70 71 72 73 74 75 76 77 78 79 80

St. Tech. Memo  
No. 2134.4-500-00

FIGURE 4



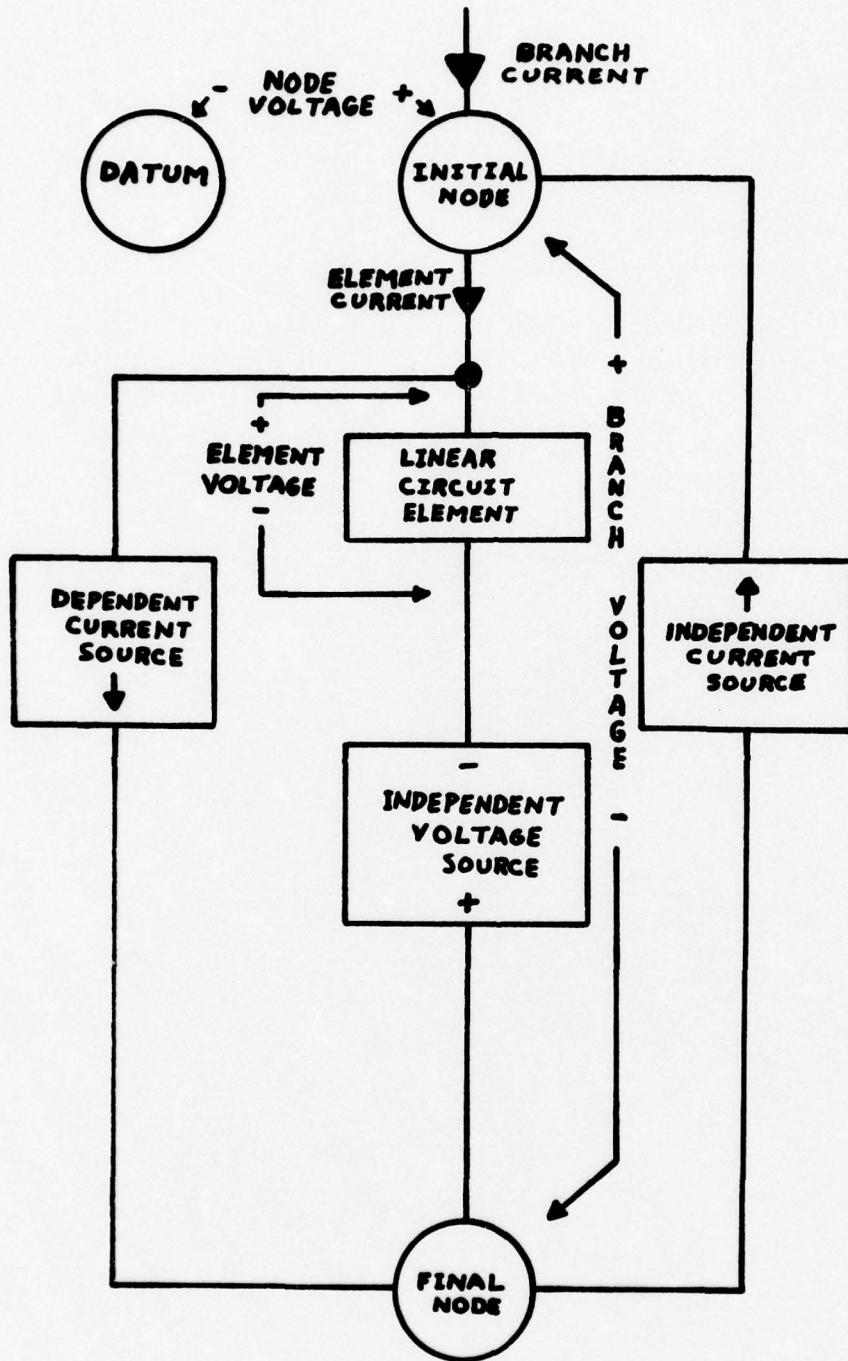

FIGURE 8: THE STANDARD BRANCH

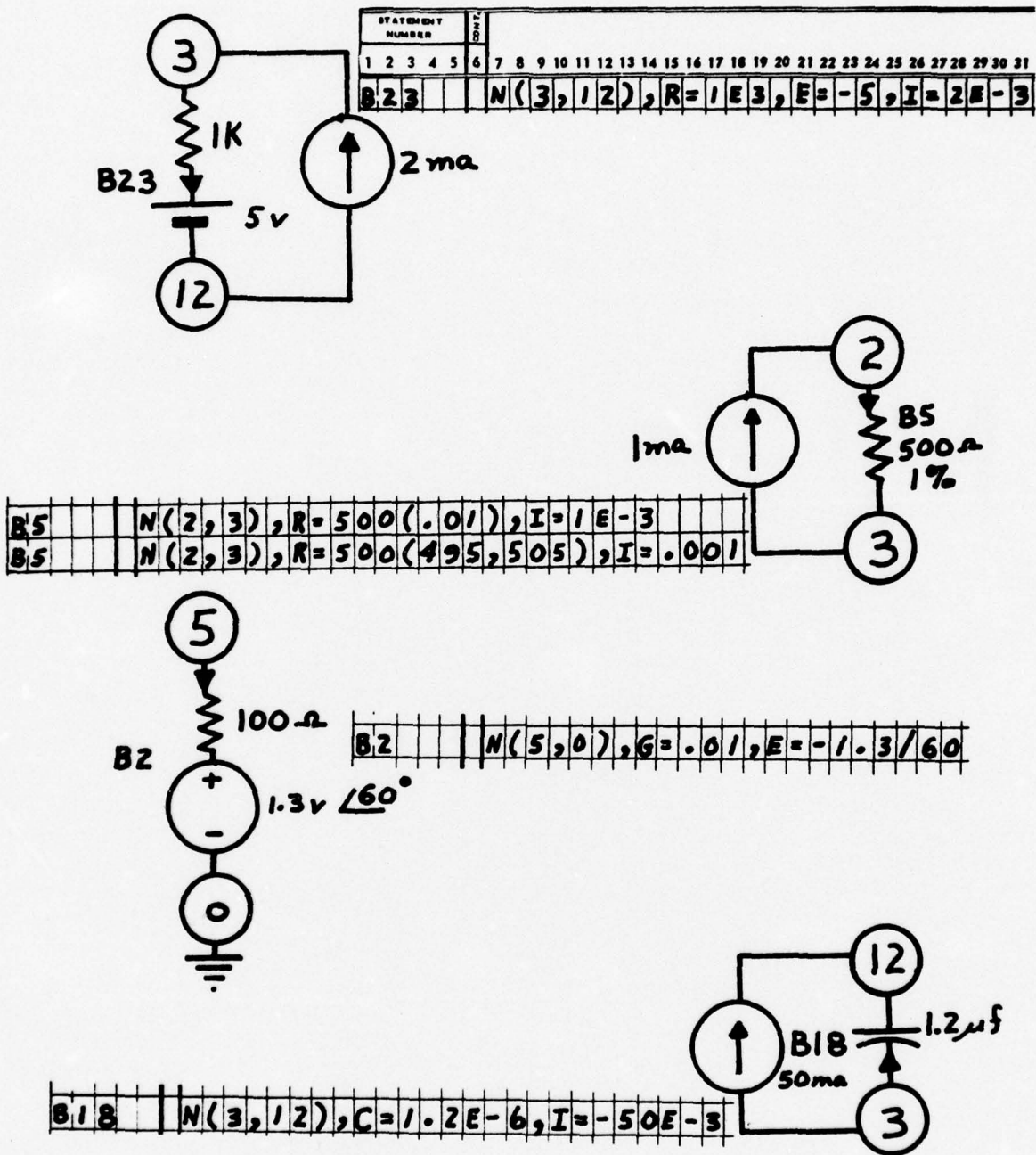
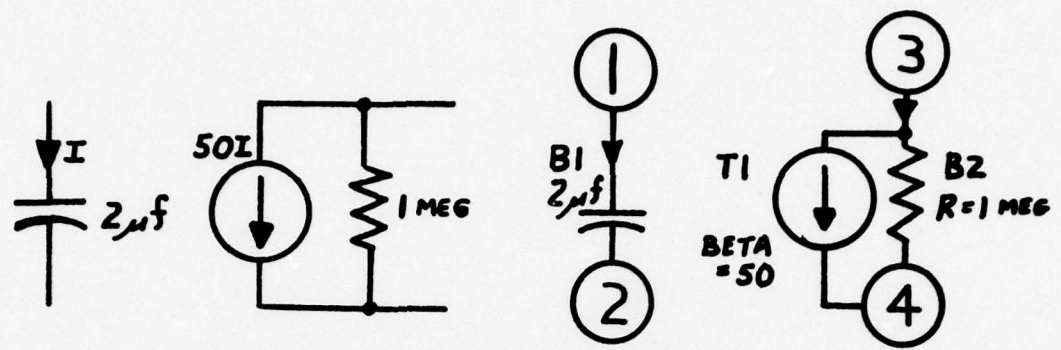
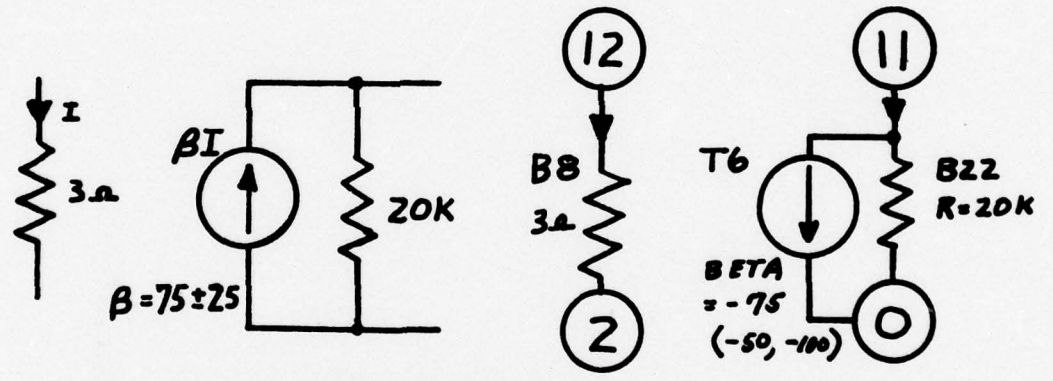

FIGURE 9 : EXAMPLES OF B-CARD DATA



	1	2	3	4	6	7	8	9	10	11	12	13	14	15	16	17	18	19	20	2
1	B1					N(1, 2),	C=2E-6													
2	B2					N(3, 4),	R=1E6													
3	T1					B(1, 2),	BETA=50													



	1	2	3	4	5	6	7	8	9	10	11	12	13	14	15	16	17	18	19	20	21	22	23	24	25	26	27	28	29	30	31	32	3
1	B8						N(12, 2),	R=3																									
2	B22						N(11, 0),	R=20E3																									
3	T6						B(8, 22),	BETA=-75																									

FIGURE 10: EXAMPLES OF T-CARD DATA

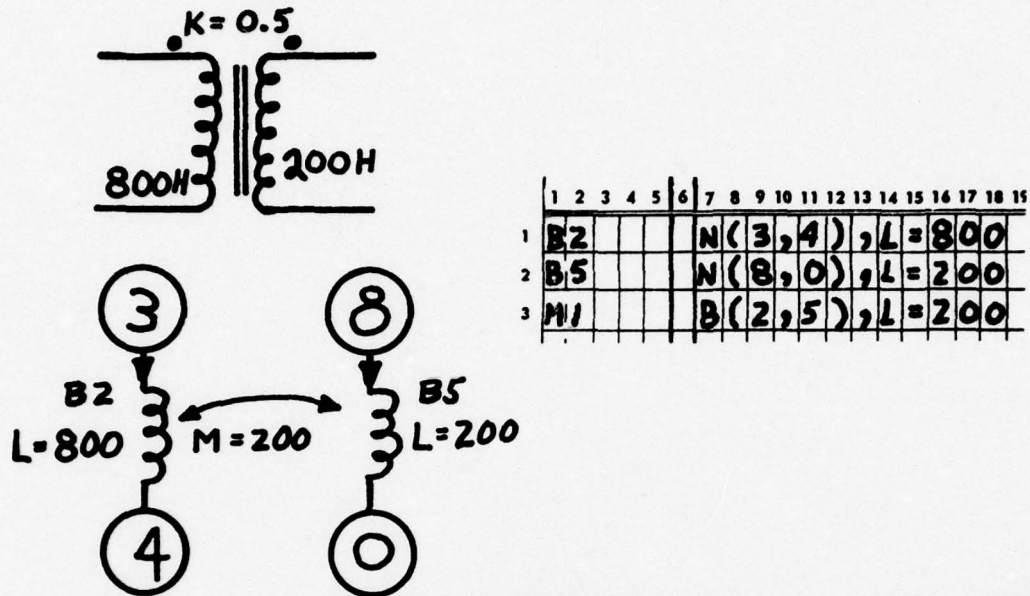

FIGURE 11: AN EXAMPLE OF M-CARD DATA

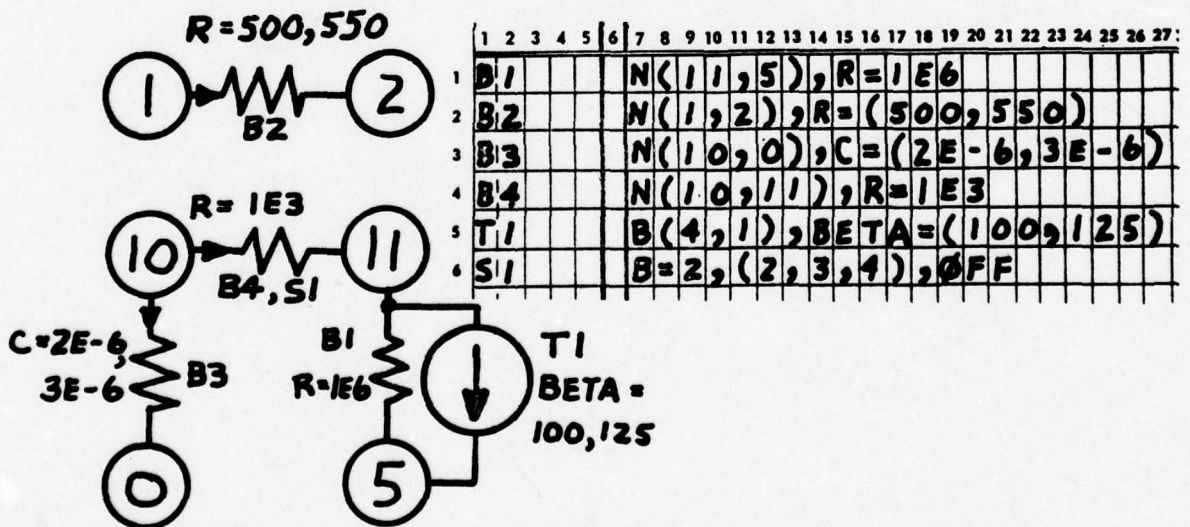

FIGURE 12: AN EXAMPLE OF S-CARD DATA

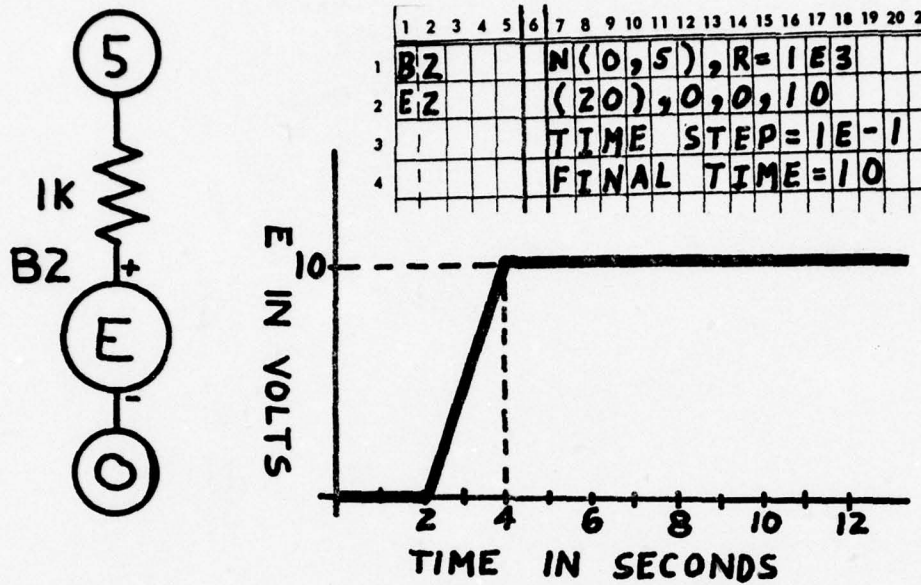

FIGURE 13: AN EXAMPLE OF A NON-PERIODIC SOURCE CARD

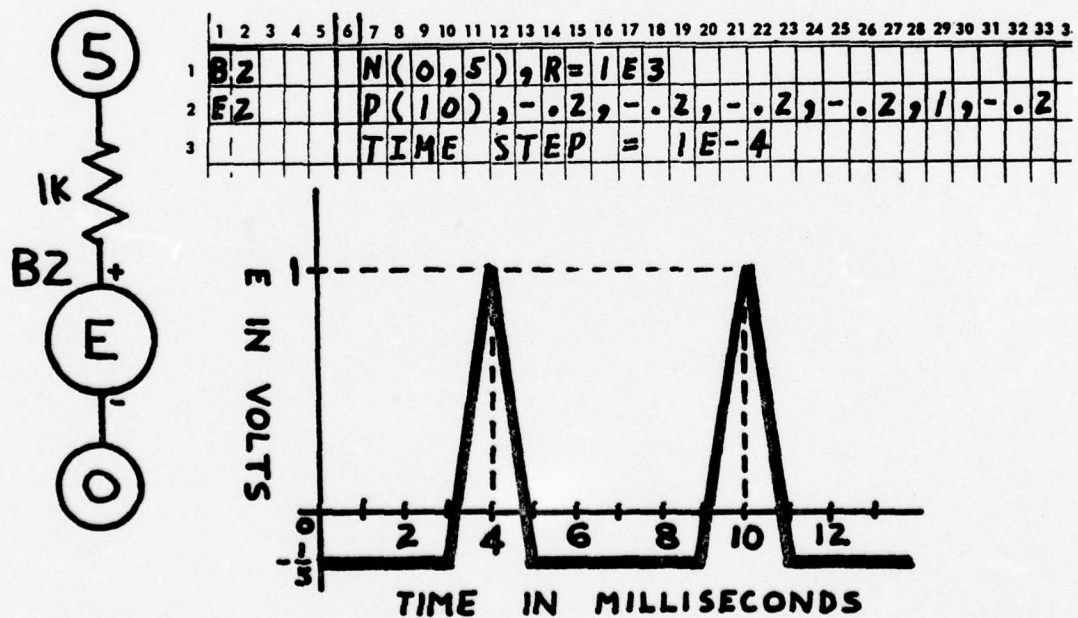

FIGURE 14: AN EXAMPLE OF A PERIODIC SOURCE CARD

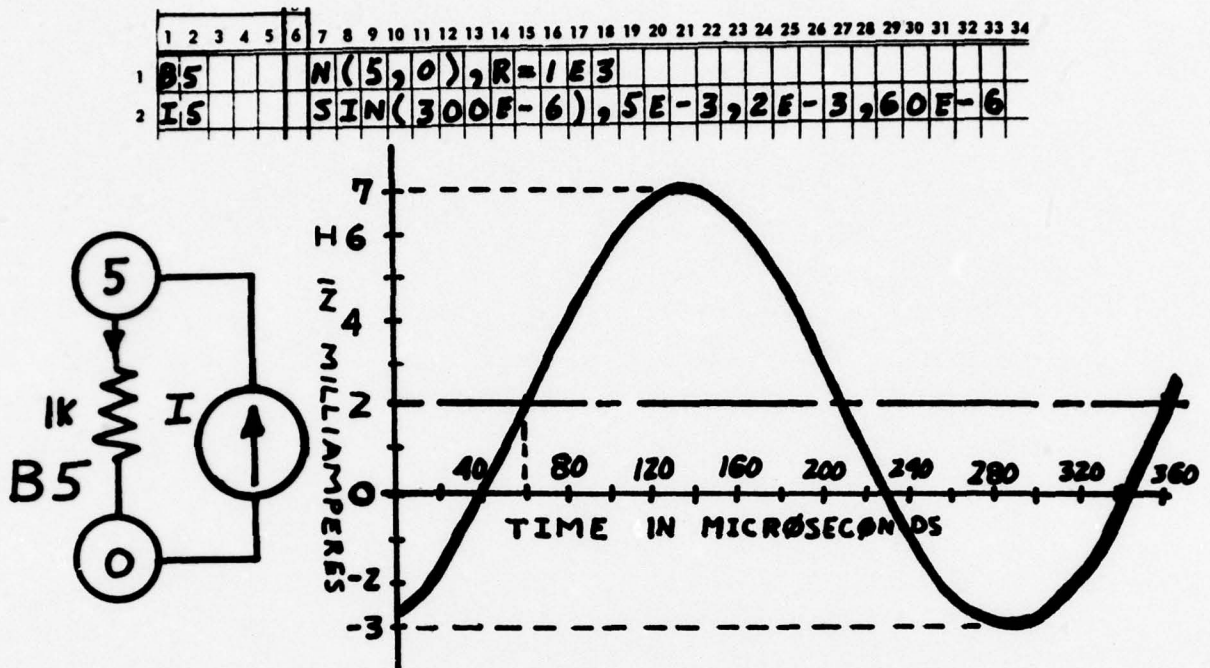

FIGURE 15: AN EXAMPLE OF A SINUSOIDAL SOURCE CARD

INDEPENDENT VOLTAGE SOURCE  
IN BRANCH B1 CHANGED TO 5V.

R = 6, 7, 8, 9, 10, 11, 12, 13, 14

8 VALUES

BETA = 100, 125, 150, 175, 200

4 VALUES

	1	2	3	4	5	6	7	8	9	10	11	12	13	14	15	16	17	18	19	20	21	22	2																
1	B1						E=5																																
2																																							
3																																							
4	B5						R=6(8)14																																
5																																							
6																																							
7	T2						BETA = 100(4)200																																

FIGURE 16: DATA FOR USE WITH MODIFY-EXECUTE CARDS



	1	2	3	4	5	6	7	8	9	10	11	12	13	14	15	16	17	18	19	20	21	22	23	24	25	26	
1							T	I	M	E	S	T	E	P	=	1	E	-	6								
2							O	U	T	P	U	T	I	N	T	E	R	V	A	L	=	5					
3							I	N	I	T	I	A	L	T	I	M	E	=	2	E	-	6					
4							F	I	N	A	L	T	I	M	E	=	5	0	0	E	-	3					
5							E	Q	U	I	L	I	B	R	I	U	M										
6							S	H	O	R	T	=	.	0	0	1											
7							O	P	E	N	=	1	0	0	E	6											
8							1	E	R	R	O	R	=	1	E	-	4										
9							2	E	R	R	O	R	=	1	E	-	4										
10							3	E	R	R	O	R	=	.	0	1											

FIGURE 19: TRANSIENT ANALYSIS SOLUTION CONTROL DATA

	1	2	3	4	5	6	7	8	9	10	11	12	13	14	15	16	17	18	19	20	21	22	23	24	25	26	
1							O	U	T	P	U	T	I	N	T	E	R	V	A	L	=	1					
2							I	N	I	T	I	A	L	T	I	M	E	=	0								
3							F	I	N	A	L	T	I	M	E	=	1	E	4	9							
4							S	H	O	R	T	=	.	0	1												
5							O	P	E	N	=	1	0	E	6												
6							1	E	R	R	O	R	=	.	0	0	1										
7							2	E	R	R	O	R	=	.	0	0	1										
8							3	E	R	R	O	R	=	1													

FIGURE 20: ASSUMED SOLUTION CONTROL DATA

	1	2	3	4	5	6	7	8	9	10	11	12	13	14	15	16	17	18	19	20	21	22	23	24	25	26	27	28	29	30	
1							P	R	I	N	T	,	C	U	R	R	E	N	T	S	,	V	O	L	T	A	G	E	S		
2							P	R	I	N	T	,	N	V	,	C	A	,	B	P											
3							P	R	I	N	T	,	B	V	,	M	I	S	C	E	L	A	N	E	O	U	S				
4							P	R	I	N	T	,	N	V	,	C	V	,	B	V											
5							P	R	I	N	T	,	B	P																	
6							P	R	I	N	T	,	B	A	,	M	I														

FIGURE 21: OUTPUT SPECIFICATION DATA

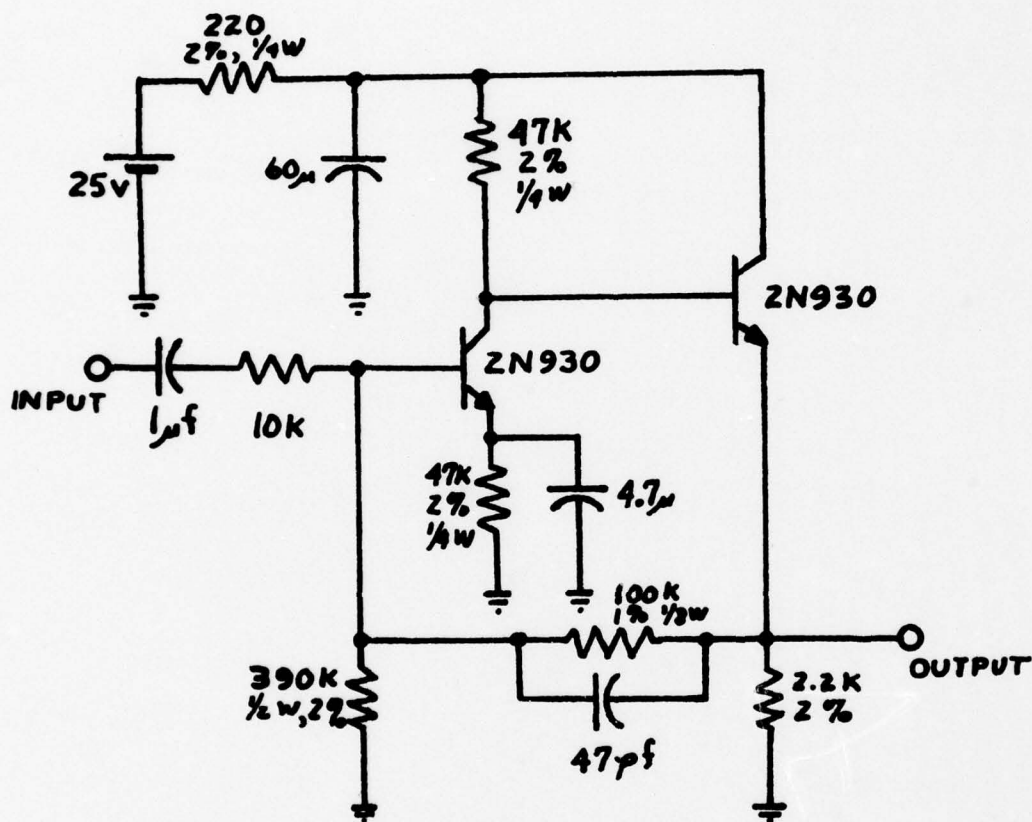

FIGURE 22: STANDARD CIRCUIT DIAGRAM

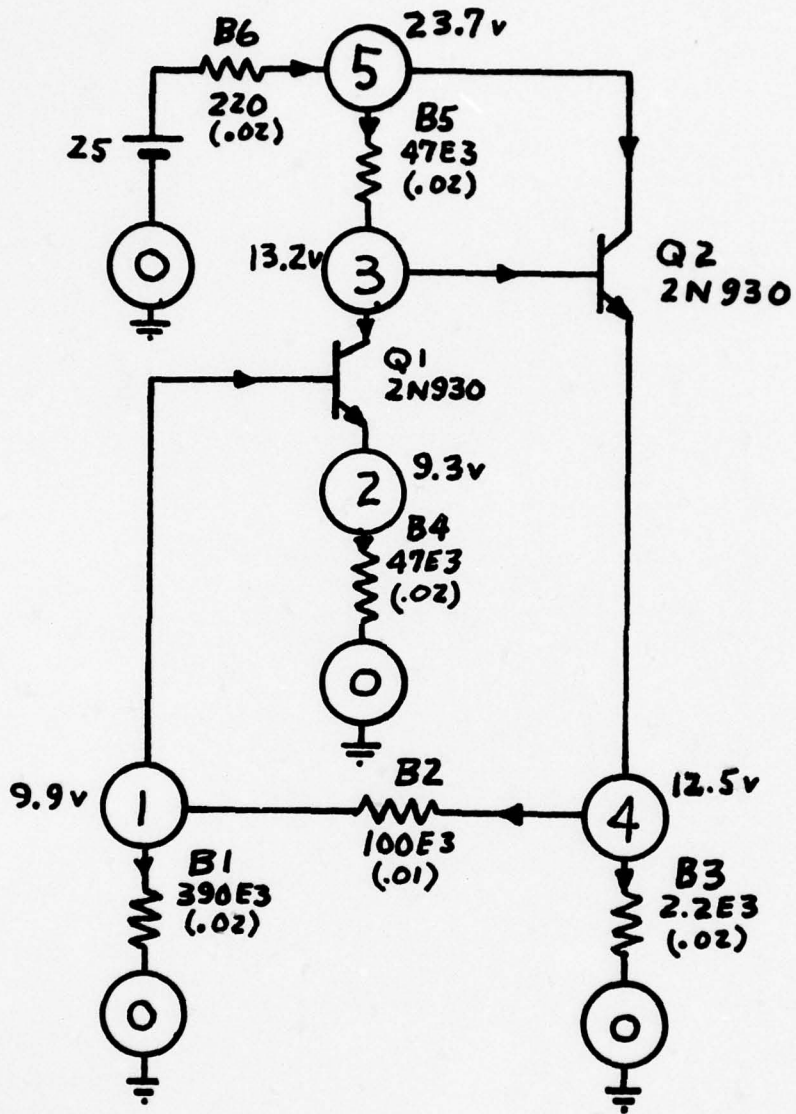

FIGURE 23: ECAP DC DIAGRAM

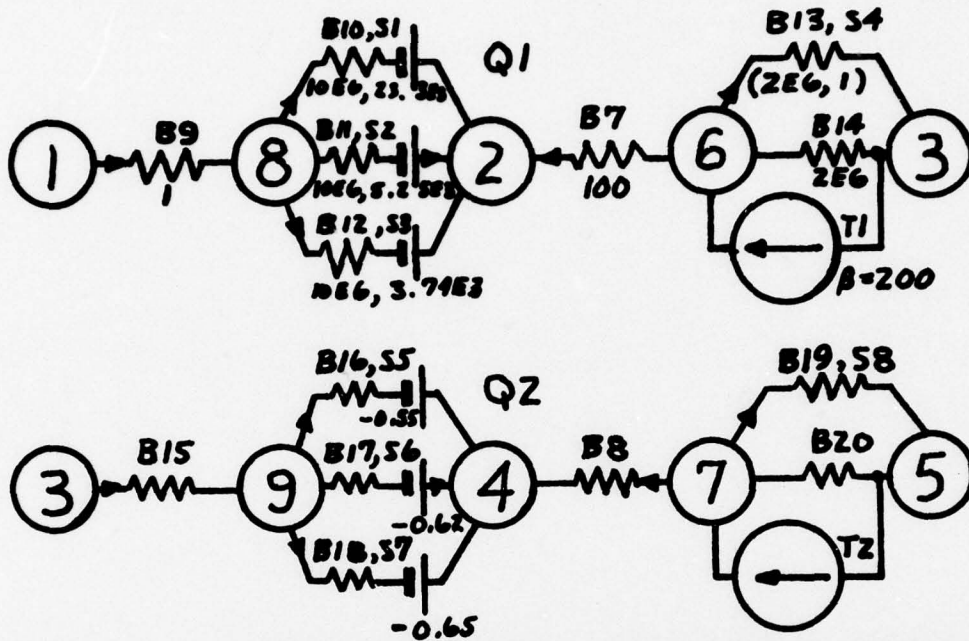

FIGURE 24: TRANSISTOR 2N930 TRANSIENT MODELS

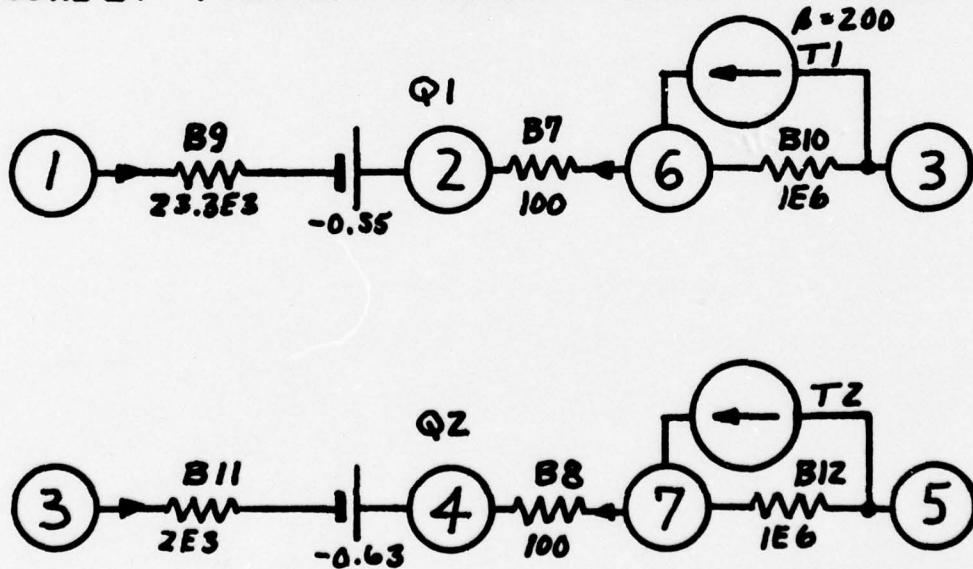

FIGURE 25: TRANSISTOR 2N930 DC MODELS

FORTRAN CODING FORM AND DATA SHEET

INDUSTRIAL-235  
 PREPARED BY ALFRED A. FILIPPINI  
 (NAME AND CODE NO.)

DATE 24 JUNE 1966 TITLE ECAP  
 JOB ORDER NO. 1-654-00-00 TRANSIENT  
 ANALYSIS

PHONE EXT. 470 PROBLEM NO. 0680  
 PAGE 1 OF 2

STATEMENT NUMBER	IDENTIFICATION
1	ECAP, IBM 704, A FILIPPINI, X4970
2	DEMONSTRATION AMPLIFIER
3	BIAS ANALYSIS
4	RUN 1, 30 JUNE 1966
5	TRANSIENT ANALYSIS 0680
6	C
7	C
8	THE CIRCUIT ELEMENTS
9	B1 N(1,0), R=390E3
10	B2 N(4,1), R=100E3
11	B3 N(4,0), R=2.2E3
12	B4 N(2,0), R=47E3
13	B5 N(5,3), R=47E3
14	B6 N(0,5), R=320
15	E6 (1), 0, 25
16	C
17	C
18	B9 Q1, 2N730
19	B10 N(1,8), R=1
20	B11 N(8,2), R=(10E6, 23.3E3), E=-0.55
21	B12 B=10, (10), OFF
22	B13 N(8,2), R=(10E6, 5.25E3), E=-0.62
23	B14 B=11, (11), OFF
24	B15 N(8,2), R=(10E6, 3.74E3), E=-0.65
25	B16 B=12, (12), OFF
26	B17 N(6,2), R=100
27	B18 N(6,3), R=(2E6, 1)

FIGURE 26: BIAS ANALYSIS DATA

ENCLOSURE 50-11490

FORTRAN CODING FORM AND DATA SHEET

NO. 00-1084-28  
 PREPARED BY ALFRED A. FILIPPINI  
 (NAME AND CODE NO.)  
 PHONE EXT. 470 PROBLEM NO. 0680

DATE 24 JUNE 1966  
 JOB ORDER NO. 1-654-00-00  
 PAGE 2 OF 2

TITLE ECAP  
TRANSIENT  
ANALYSIS

FORM NO. 100-1084-28  
 1 2 3 4 5 6 7 8 9 10 11 12 13 14 15 16 17 18 19 20 21 22 23 24 25 26 27 28 29 30 31 32 33 34 35 36 37 38 39 40 41 42 43 44 45 46 47 48 49 50 51 52 53 54 55 56 57 58 59 60 61 62 63 64 65 66 67 68 69 70 71 72 73 74 75 76 77 78 79 80

FORTRAN STATEMENT

1	S4	B=13,(13),OFF
2	B14	N(3,6),R=2E6
3	T1	B(9,14),BETA=200
4	C	
5	C	Q2,2M930
6	B15	N(3,9),R=1
7	B16	N(9,4),R=(1.0E6,23.3E3),E=-0.5
8	S5	B=16,(16),OFF
9	B17	N(9,4),R=(1.0E6,5.25E3),E=-0.62
10	S6	B=17,(17),OFF
11	B18	N(9,4),R=(1.0E6,3.74E3),E=-0.65
12	S7	B=18,(18),OFF
13	B8	N(7,4),R=100
14	B19	N(7,5),R=(2E6,1)
15	S8	B=19,(19),OFF
16	B20	N(5,7),R=256
17	TZ	B(15,20),BETA=200
18	C	
19		TIME STEP = 1E-6
20		FINAL TIME = 1E-6
21		PRINT,VOLTAGES
22		EXECUTE
23		
24		
25		

NSI Tech Memo  
 No 2134-4-607-50

FIGURE 27: BIAS ANALYSIS DATA

Less than 1 hour			PRODUCTION			Less than 1 hour				
REQUESTOR					OPERATOR					
IN		Job Code	Est. (MIN)	Requestor	Remarks	Proc. H-200	Batch Input		Prog. in 704	Output Tape
Day	Time						BIN 2	BCD 3		
6/30	1845	0680	20	A. FELIPPINE	ECAP TRANSFER					

FIGURE 28: PRODUCTION LOG



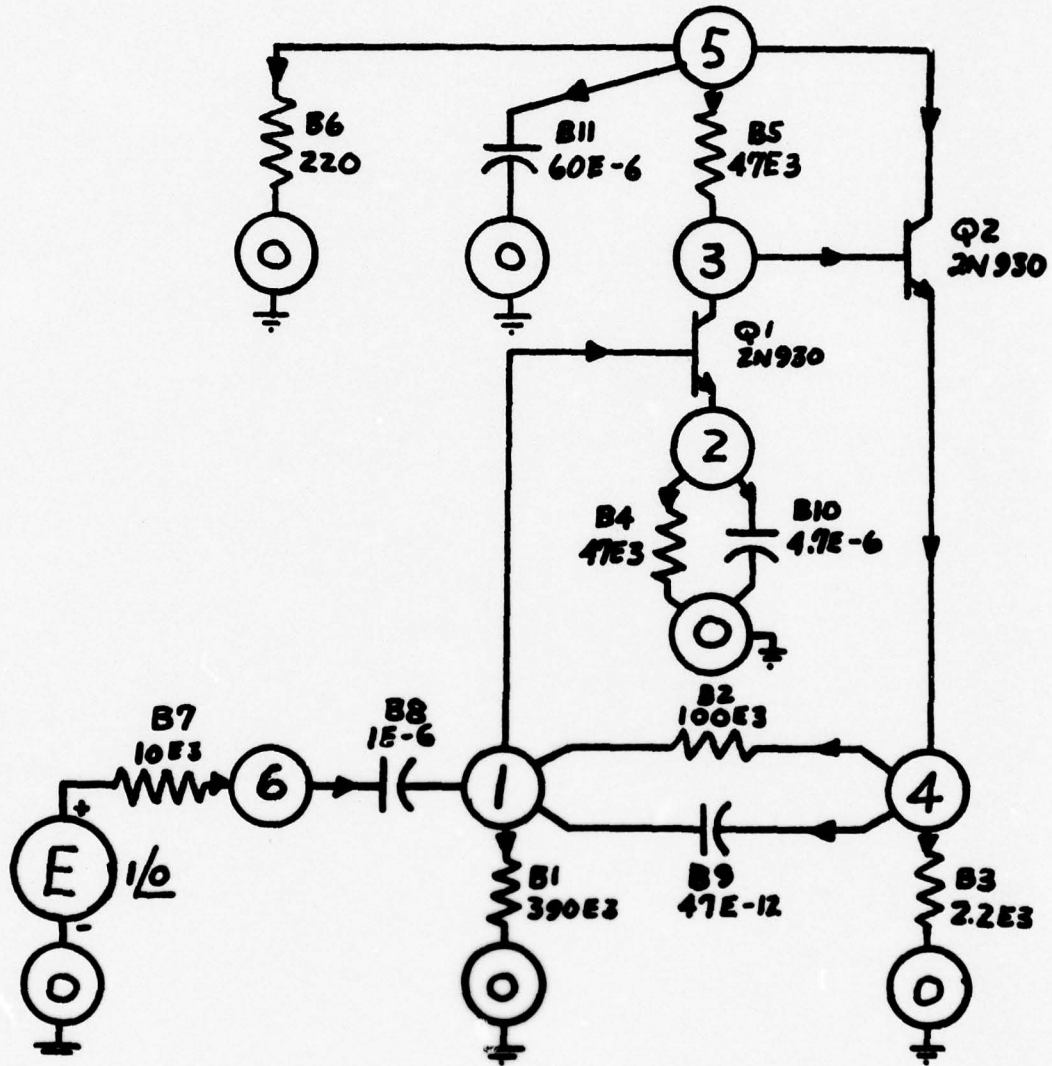

FIGURE 30: ECAP AC CIRCUIT DIAGRAM

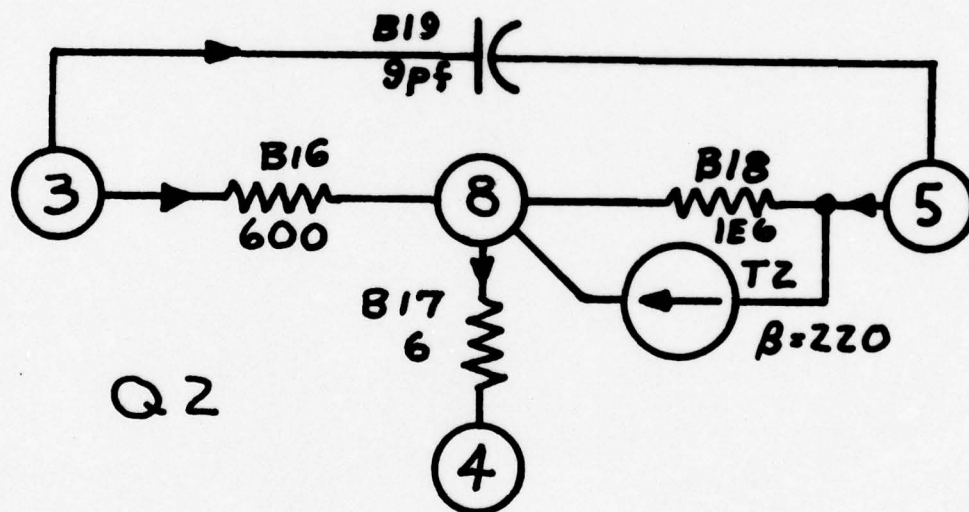
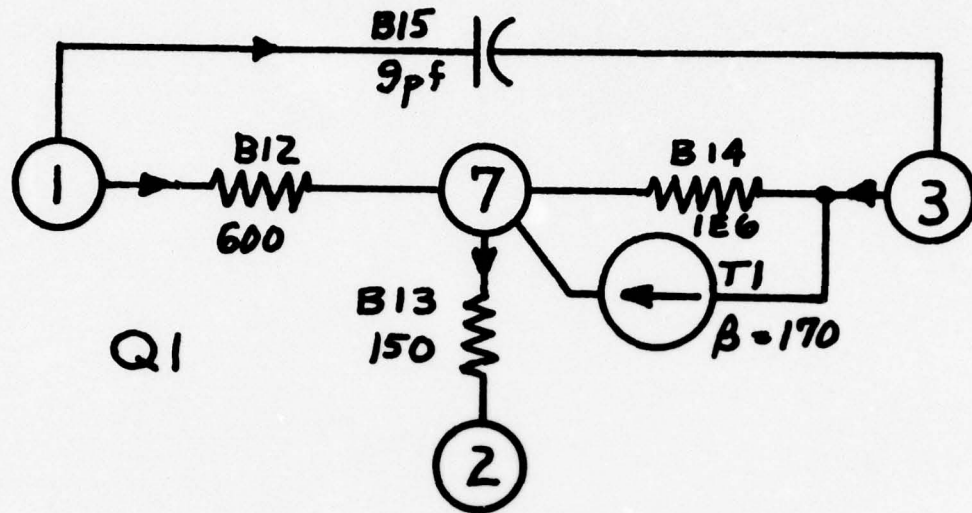

FIGURE 31: TRANSISTOR 2N930 AC MODELS

USL Tech Memo  
No 2134.4-597-67

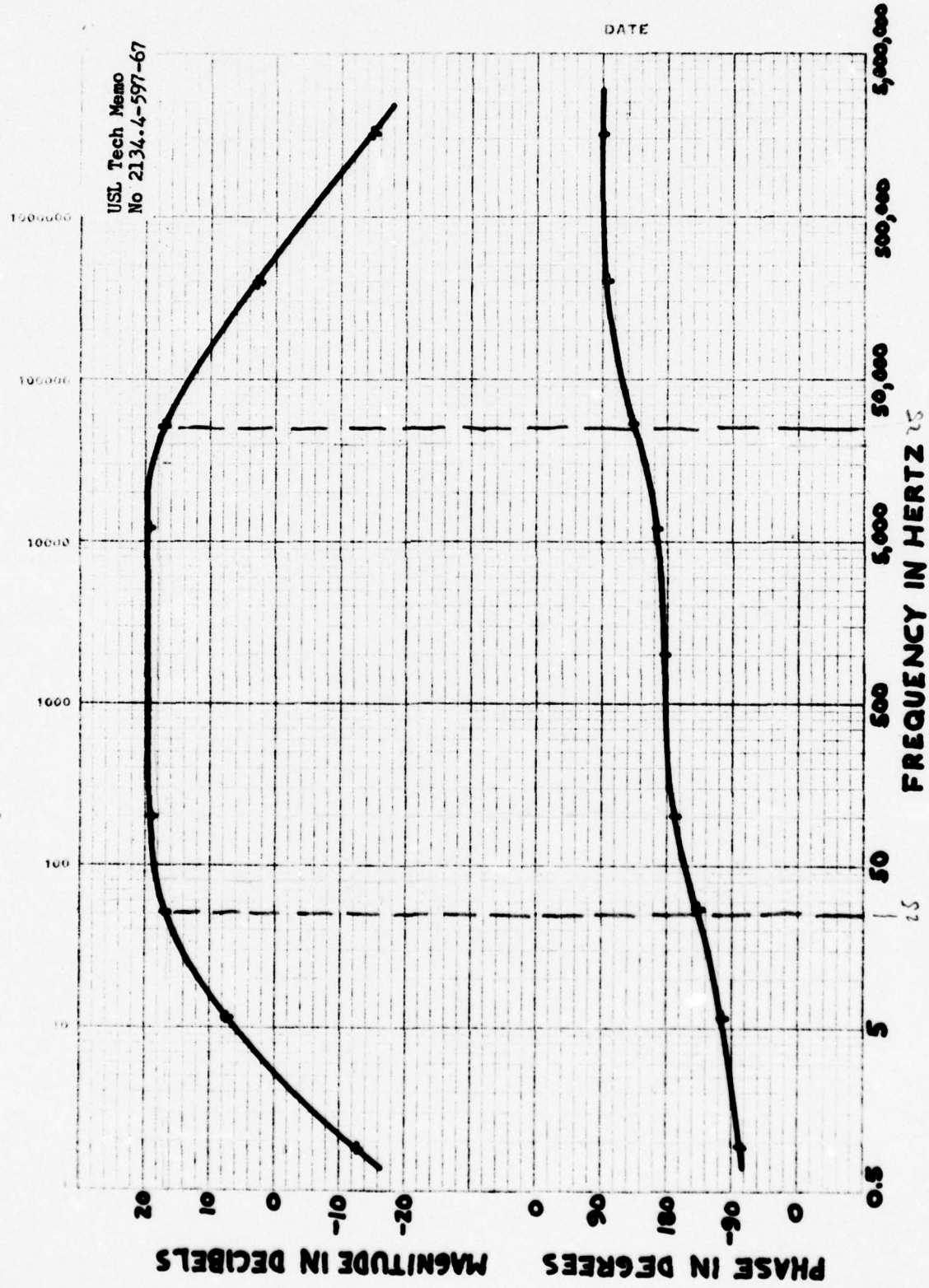

FIGURE 32 : DEMONSTRATION AMPLIFIER GAIN VERSUS DRIVING SOURCE FREQUENCY

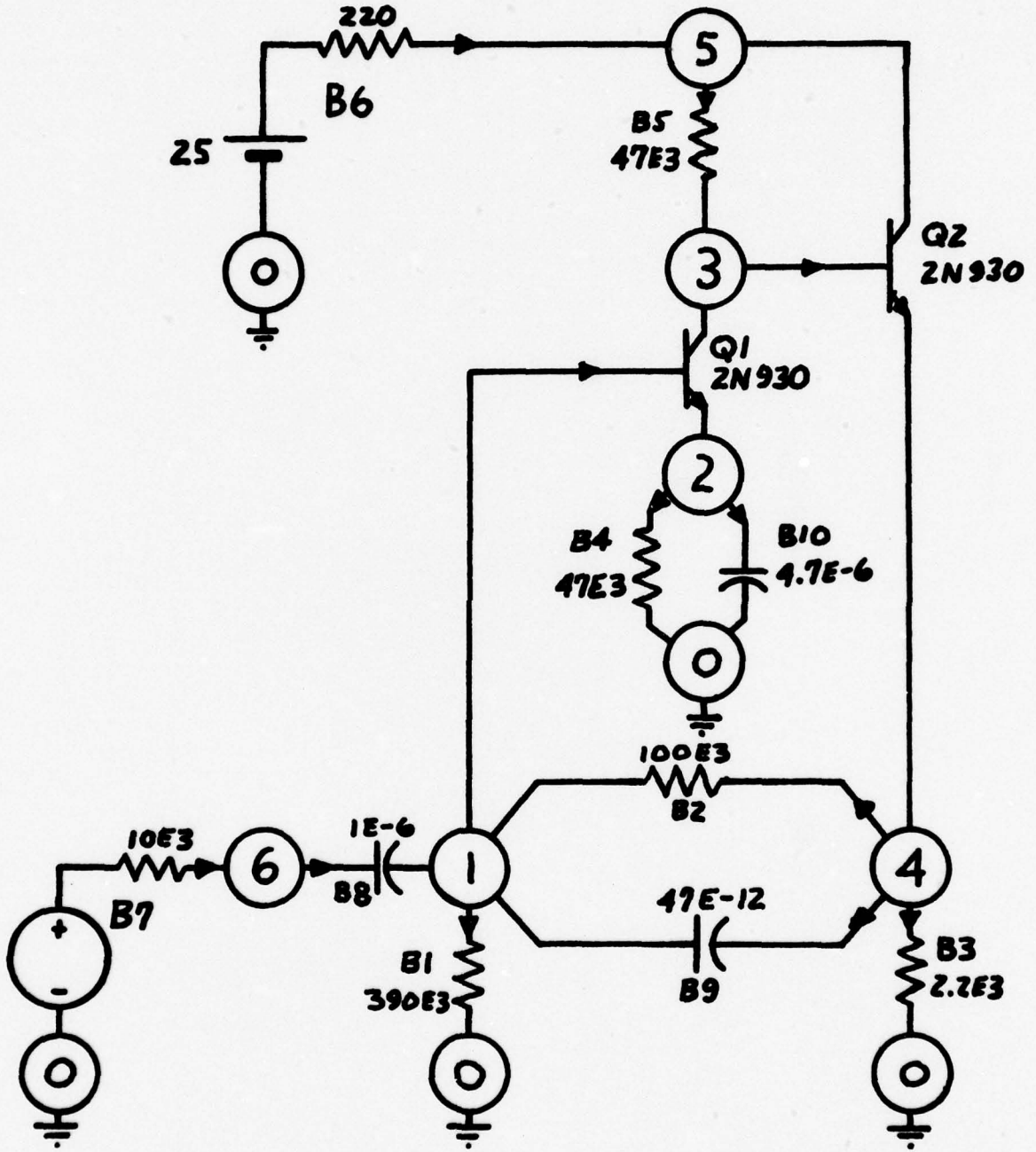

FIGURE 33: ECAP TRANSIENT DIAGRAM

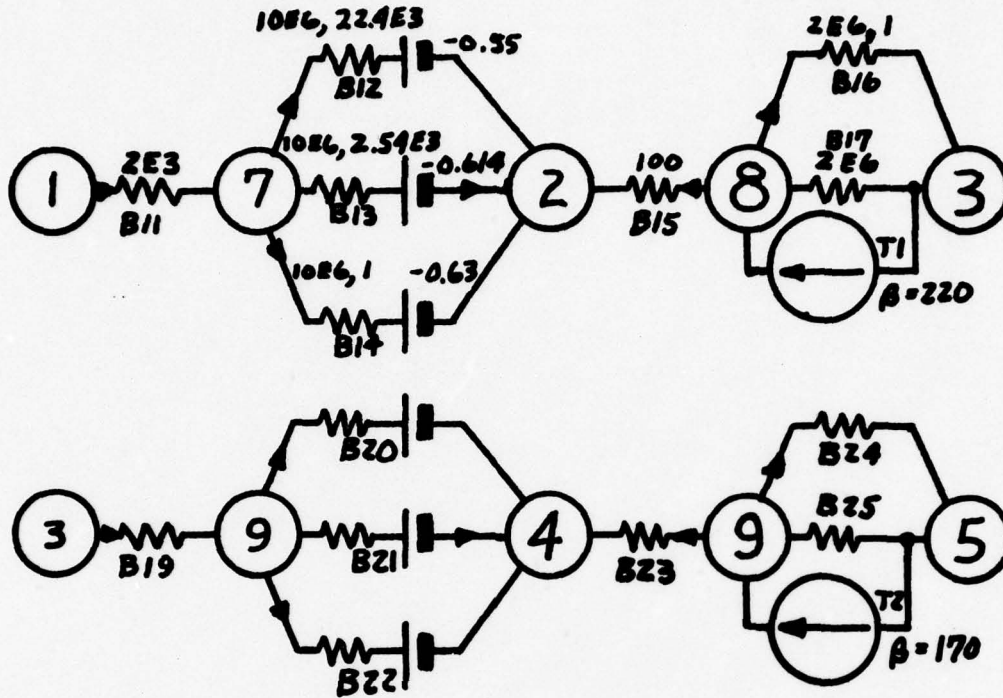

FIGURE 34: TRANSISTOR 2N930 TRANSIENT MODELS

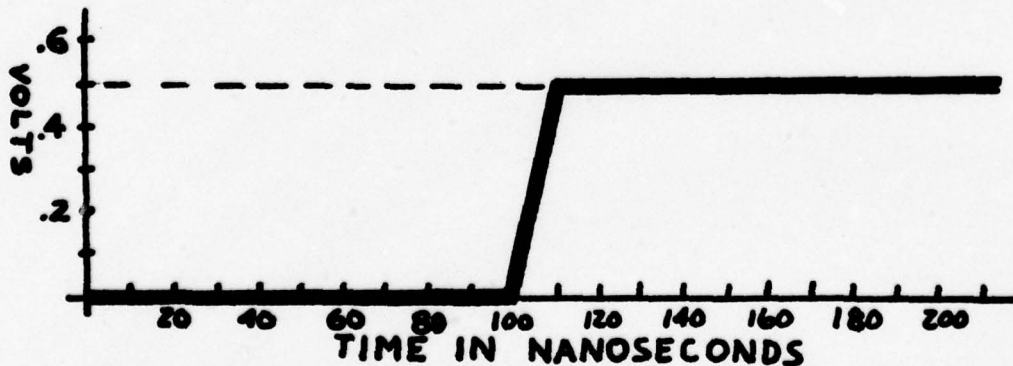
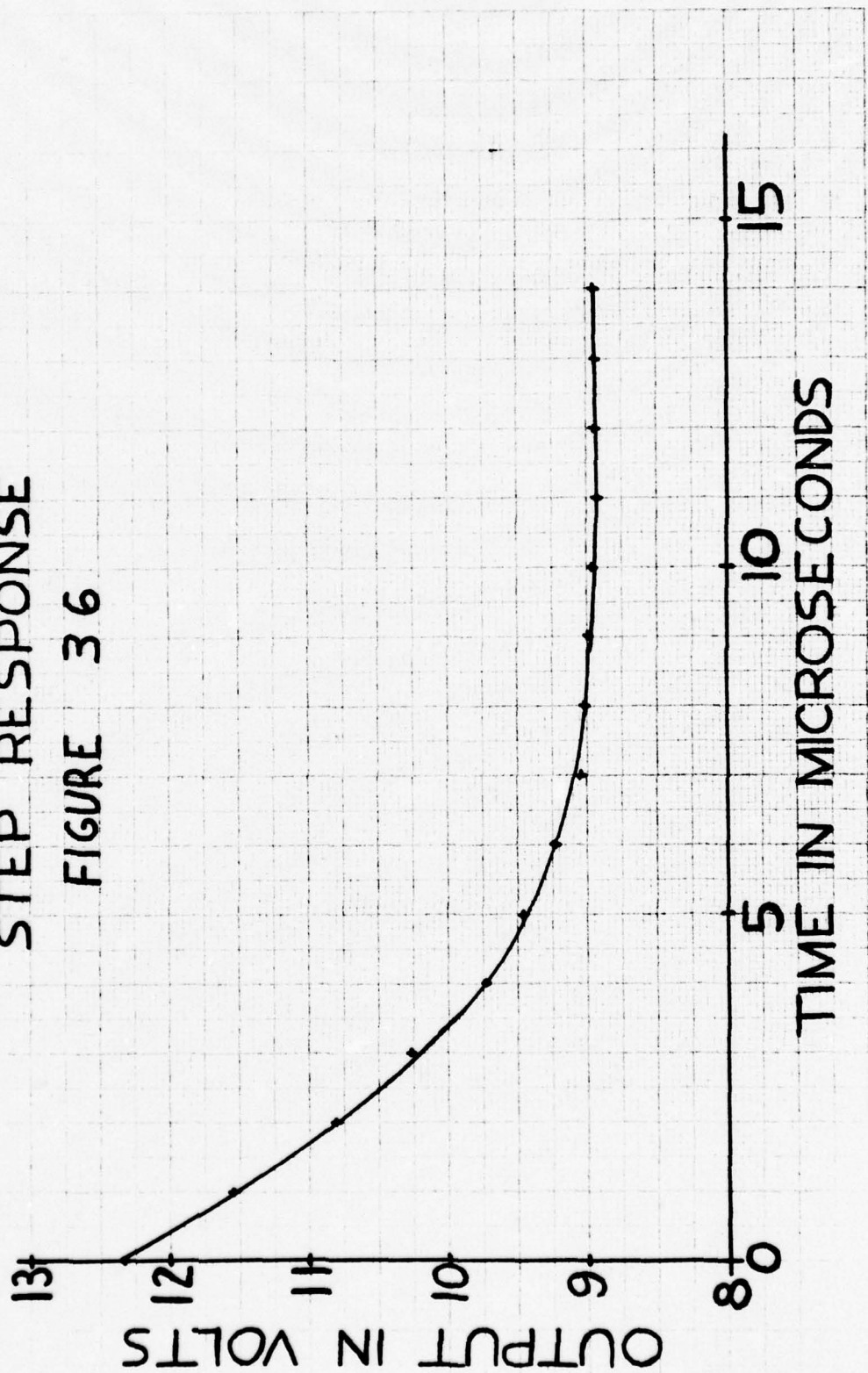

FIGURE 35: INPUT STEP FUNCTION

# DEMONSTRATION AMPLIFIER STEP RESPONSE FIGURE 36



# APPENDIX A

USL Tech Memo  
No 2134.4-597-67

C ECAP, IBM 704, A FILIPPINI, CODE 934.4, X 470  
C DEMONSTRATION AMPLIFIER  
C BIAS ANALYSIS  
C RUN 1, 30 JUNE 1966  
C

TRANSIENT ANALYSIS 0680

C THE CIRCUIT ELEMENTS

B1 N(1,0),R=390E3  
B2 N(4,1),R=100E3  
B3 N(4,0),R=2.2E3  
B4 N(2,0),R=47E3  
B5 N(5,3),R=47E3  
B6 N(0,5),R=220  
E6 (1),0.25

C  
C G1, 2N930  
B9 N(1,8),R=1  
B10 N(8,2),R=(10E6,23.3E3),E=-0.55  
S1 B=10,(10),OFF  
B11 N(8,2),R=(10E6,5.25E3),E=-0.62  
S2 B=11,(11),OFF  
B12 N(8,2),R=(10E6,3.74E3),E=-0.65  
S3 B=12,(12),OFF  
B7 N(6,2),R=100  
B13 N(6,3),R=(2E6,1)  
S4 B=13,(13),OFF  
B14 N(3,6),R=2E6  
T1 B(9,14),BETA=200

C  
C G2, 2N930  
B15 N(3,9),R=1  
B16 N(9,4),R=(10E6,23.3E3),E=-0.55  
S5 B=16,(16),OFF  
B17 N(9,4),R=(10E6,5.25E3),E=-0.62  
S6 B=17,(17),OFF  
B18 N(9,4),R=(10E6,3.74E3),E=-0.65  
S7 B=18,(18),OFF  
B8 N(7,4),R=100  
B19 N(7,5),R=(2E6,1)  
S8 B=19,(19),OFF  
B20 N(5,7),R=2E6  
T2 B(15,20),BETA=200

C  
TIME STEP=1E-6  
FINAL TIME=1E-6  
PRINT,VOLTAGES  
EXECUTE

T = 0.

NODES	VOLTAGES			
1- 4	-0.15363346E-01	-0.44727094E-00	0.45212407E-00	-0.24493132E-01
5- 8	0.45265925E-02	-0.44821733E-00	-0.25611684E-01	-0.15363295E-01
9- 9	0.45212413E-00			

T = 0.2929687E-08

NODES		VOLTAGES			
1-	4	-0.97963133E-02	-0.44292166E-00	0.51959780E 00	-0.17481074E-01
5-	8	0.77040417E-01	-0.44385883E-00	-0.18281265E-01	-0.97962619E-02
9-	9	0.51959784E 00			

SWITCH 5 IS ON

T = 0.2929687E-08

NODES		VOLTAGES			
1-	4	-0.15550839E-01	-0.44651127E-00	0.52468302E 00	-0.24756540E-01
5-	8	0.77786834E-01	-0.44745601E-00	-0.25886927E-01	-0.15550837E-01
9-	9	0.52468308E 00			

T = 0.3311443E-07

NODES		VOLTAGES			
1-	4	0.32121038E-00	-0.22741430E-00	0.97287805E 00	0.40073721E-00
5-	8	0.78861658E 00	-0.22789641E-00	0.41893829E-00	0.32121041E-00
9-	9	0.97287714E 00			

SWITCH 1 IS ON

T = 0.3311443E-07

NODES		VOLTAGES			
1-	4	0.32167733E-00	-0.22825555E-00	0.97348746E 00	0.40131570E-00
5-	8	0.78856195E 00	-0.22873920E-00	0.41954306E-00	0.32167736E-00
9-	9	0.97348655E 00			

T = 0.1058197E-06

NODES		VOLTAGES			
1-	4	0.10229366E 01	0.47079632E-00	0.19096031E 01	0.12900408E 01
5-	8	0.25136025E 01	0.47179047E-00	0.13486478E 01	0.10229366E 01
9-	9	0.19096002E 01			

SWITCH 6 IS ON

T = 0.1058197E-06

NODES		VOLTAGES			
1-	4	0.10227955E 01	0.47065694E-00	0.19097744E 01	0.12898630E 01
5-	8	0.25136194E 01	0.47165079E-00	0.13484622E 01	0.10227965E 01
9-	9	0.19097715E 01			

T = 0.3511953E-06

NODES		VOLTAGES			
1- 4	0.34408688E 01	0.24811011E 01	0.50044944E 01	0.43544181E 01	
5- 8	0.83287373E 01	0.28871907E 01	0.45522577E 01	0.34408685E 01	
9- 9	0.50044745E 01				

SWITCH 7 IS ON

T = 0.3511953E-06

NODES		VOLTAGES			
1- 4	0.34408967E 01	0.24811305E 01	0.50044653E 01	0.43544535E 01	
5- 8	0.83287448E 01	0.28872201E 01	0.45522960E 01	0.34408964E 01	
9- 9	0.50044554E 01				

T = 1.0000000E-06

NODES		VOLTAGES			
1- 4	0.98514202E 01	0.92714269E 01	0.13166136E 02	0.12478881E 02	
5- 8	0.23702452E 02	0.92910255E 01	0.13045865E 02	0.98514194E 01	
9- 9	0.13166107E 02				

# APPENDIX B

```

C  PCAP, IFC 704, A FILIPPINI, CODE 934.4, X 470
C  DEMONSTRATION AMPLIFIER
C  PLAN 1, 12 JULY 1966
C
C  DC ANALYSIS 0679
C
C  THE CIRCUIT ELEMENTS
B1  N(1,0),R=390E3(.02)
B2  N(4,1),R=100E3(.01)
B3  N(4,0),R=2.2E3(.02)
B4  N(2,0),R=47E3(.02)
B5  N(5,3),R=47E3(.02)
B6  N(0,5),R=220(.02),E=25
C
C  Q1, 2N930
B9  N(1,2),R=23.3E3,E=-0.55
B7  N(6,2),R=100
B10 N(3,6),R=1E6
T1  R(9,10),BETA=200
C
C  Q2, 2N930
B11 N(3,4),R=2E3,E=-.63
B8  N(7,4),R=100
B12 N(5,7),R=1E6
T2  R(11,12),BETA=200
C
C  WORST CASE, 1,2,3,4,5
C  PRINT,CURRENTS,RP
C  EXECUTE
    
```

## ELEMENT CURRENTS

BRANCHES	CURRENTS			
1- 4	0.25239929E-04	0.26202131E-04	0.56653570E-02	0.19725858E-03
5- 8	0.22456087E-03	0.58878519E-02	0.19629239E-03	0.56632851E-02
9- 12	0.96219131E-06	0.19629779E-03	0.28262797E-04	0.56632339E-02

## ELEMENT POWER LOSSES

BRANCHES	POWER LOSSES			
1- 4	0.24845107E-03	0.68655168E-04	0.70611795E-01	0.18288145E-02
5- 8	0.23700966E-02	0.76266959E-02	0.38530705E-05	0.32072799E-02
9- 12	0.21571422E-07	0.75761691E-03	0.15975714E-05	0.60452522E-01

## WORST CASE SOLUTIONS FOR NODE VOLTAGES

NODE	WCMIN	NOMINAL	WCMAX
1	0.96191663E 01	0.98435725E 01	0.10069151E 02
2	0.90468474E 01	0.92711534E 01	0.94966333E 01
3	0.12884086E 02	0.13150311E 02	0.13417452E 02
4	0.12197650E 02	0.12463785E 02	0.12730835E 02
5	0.23633743E 02	0.23704672E 02	0.23772508E 02

T1 MODIFY  
T2 PETA=150  
PETA=150  
EXECUTE

ELEMENT CURRENTS

BRANCHES	CURRENTS			
1- 4	0.24767275E-04	0.26021074E-04	0.55733385E-02	0.19319198E-03
5- 8	0.22894789E-03	0.57912912E-02	0.19193649E-03	0.55623434E-02
9- 12	0.12538192E-05	0.19193902E-03	0.37009779E-04	0.55623750E-02

ELEMENT POWER LOSSES

BRANCHES	POWER LOSSES			
1- 4	0.23923299E-03	0.67709628E-04	0.68336625E-01	0.17541877E-02
5- 8	0.24636056E-02	0.73785920E-02	0.36839616E-05	0.30939665E-02
9- 12	0.36629057E-07	0.74206451E-03	0.27394474E-05	0.60676259E-01

# APPENDIX C

C ECAP, IBM 704, A FILIPPINI, CODE 934.4, X 470  
 C DEMONSTRATION AMPLIFIER  
 C RLN 1, 13 JULY 1966  
 C

AC ANALYSIS 0678

C THE CIRCUIT ELEMENTS

B1 N(1,0) \*R=390E3  
 B2 N(4,1) \*R=100E3  
 B3 N(4,0) \*R=2.2E3  
 B4 N(2,0) \*R=47E3  
 B5 N(5,3) \*R=47E3  
 B6 N(0,5) \*R=220  
 B7 N(0,6) \*R=10E3 \*E=1  
 B8 N(6,1) \*C=1E-6  
 B9 N(4,1) \*C=47E-12  
 B10 N(2,0) \*C=4.7E-6  
 B11 N(5,0) \*C=60E-6

C  
 C G1, 2N930  
 B12 N(1,7) \*R=600  
 B13 N(7,2) \*R=150  
 B14 N(3,7) \*R=1E6  
 T1 R(12,14) \*BETA=170  
 B15 N(1,3) \*C=9E-12

C  
 C G2, 2N930  
 B16 N(3,8) \*R=600  
 B17 N(8,4) \*R=6  
 B18 N(5,8) \*R=1E6  
 T2 R(16,18) \*BETA=220  
 B19 N(3,5) \*C=9E-12

C  
 FREQUENCY=1E3  
 PRINT,VOLTAGES  
 EXECUTE

FREQ = 0.99999999E 03

	NCDES	NODE VOLTAGES			
MAG	1- 4	0.35193714E-01	0.75729779E-02	0.95088840E 01	0.94705141E 01
PHA		-0.12766499E 02	-0.90298733E 02	0.17943960E 03	0.17943946E 03
MAG	5- 8	0.11080429E-01	0.41701452E-01	0.34395122E-01	0.94969132E 01
PHA		-0.89836828E 02	-0.33704266E 02	-0.13059527E 02	0.17943956E 03

MODIFY  
FREQUENCY=.1(2)52  
EXCLTF

FREQ = 0.99999999E-01

		NODES				NODE VOLTAGES			
MAG	1- 4	0.29921338E-01	0.29823735E-01	0.24234424E-01	0.24831239E-01				
PHA		0.84738354E 02	0.84712443E 02	-0.87310762E 02	-0.87309933E 02				
MAG	5- 8	0.24628855E-02	0.99979306E 00	0.29918920E-01	0.24902228E-01				
PHA		0.92006992E 02	-0.35900725E-00	0.84737742E 02	-0.87310503E 02				

FREQ = 0.20700000E-00

		NODES				NODE VOLTAGES			
MAG	1- 4	0.59164153E-01	0.58973136E-01	0.50691719E-01	0.50482222E-01				
PHA		0.79552501E 02	0.79500675E 02	-0.84837802E 02	-0.84836232E 02				
MAG	5- 8	0.49997230E-02	0.99918994E 00	0.59161371E-01	0.50626349E-01				
PHA		0.93819924E 02	-0.71223165E 00	0.79551274E 02	-0.84837313E 02				

FREQ = 0.39999999E-00

		NODES				NODE VOLTAGES			
MAG	1- 4	0.11331765E-00	0.11294783E-00	0.10710716E-00	0.10666637E-00				
PHA		0.69677076E 02	0.69573427E 02	-0.81123766E 02	-0.81121187E 02				
MAG	5- 8	0.10513610E-01	0.99701495E 00	0.11330848E-00	0.10696962E-00				
PHA		0.96330763E 02	-0.13828718E 01	0.69674623E 02	-0.81122964E 02				

FREQ = 0.79999999E 00

		NODES				NODE VOLTAGES			
MAG	1- 4	0.19639584E-00	0.19575395E-00	0.24292622E-00	0.24193461E-00				
PHA		0.52986435E 02	0.52779137E 02	-0.78789926E 02	-0.78786913E 02				
MAG	5- 8	0.23403912E-01	0.99088413E 00	0.19637991E-00	0.24261681E-00				
PHA		0.96661030E 02	-0.25343711E 01	0.52981531E 02	-0.78788990E 02				

FREQ = 0.16000000E 01

		NODES	NODE VOLTAGES			
MAG	1- 4	0.27763262E-00	0.27671977E-00	0.56100322E 00	0.55872971E 00	
PHA		0.31637273E 02	0.31222683E 02	-0.82321507E 02	-0.82319245E 02	
MAG	5- 8	0.53746834E-01	0.98070297E 00	0.27760985E-00	0.56029382E 00	
PHA		0.89571081E 02	-0.43592455E 01	0.31627464E 02	-0.82320801E 02	

FREQ = 0.31999999E 01

		NODES	NODE VOLTAGES			
MAG	1- 4	0.31833018E-00	0.31725867E-00	0.12074625E 01	0.12025844E 01	
PHA		0.12085848E 02	0.11256709E 02	-0.90231179E 02	-0.90229888E 02	
MAG	5- 8	0.11244901E-00	0.96918606E 00	0.31830298E-00	0.12059404E 01	
PHA		0.74638402E 02	-0.77386997E 01	0.12066231E 02	-0.90230775E 02	

FREQ = 0.63999999E 01

		NODES	NODE VOLTAGES			
MAG	1- 4	0.32245015E-00	0.32126407E-00	0.24303360E 01	0.24205264E 01	
PHA		-0.44886366E 01	-0.61465853E 01	-0.10060769E 03	-0.10060703E 03	
MAG	5- 8	0.20678278E-00	0.94485337E 00	0.32241804E-00	0.24272751E 01	
PHA		0.51372855E 02	-0.14613809E 02	-0.45278639E 01	-0.10060748E 03	

FREQ = 0.12799999E 02

		NODES	NODE VOLTAGES			
MAG	1- 4	0.29377698E-00	0.29232989E-00	0.45151708E 01	0.44969501E 01	
PHA		-0.21620170E 02	-0.24933373E 02	-0.11574287E 03	-0.11574254E 03	
MAG	5- 8	0.29859127E-00	0.86420756E 00	0.29373089E-00	0.45094857E 01	
PHA		0.17595067E 02	-0.27384673E 02	-0.21698509E 02	-0.11574277E 03	

FREQ = 0.25549999E 02

		NODES				NODE VOLTAGES			
MAG	1- 4	0.22422507E-00	0.22201126E-00	0.70230606E 01	0.69947210E 01				
PHA		-0.39763315E 02	-0.46367864E 02	-0.13607385E 03	-0.13607369E 03				
MAG	5- 8	0.28998535E-00	0.66606383E 00	0.22413822E-00	0.70142188E 01				
PHA		-0.20789763E 02	-0.45435550E 02	-0.39918631E 02	-0.13607380E 03				

FREQ = 0.51199999E 02

		NODES				NODE VOLTAGES			
MAG	1- 4	0.13944293E-00	0.13540547E-00	0.86642677E 01	0.86293058E 01				
PHA		-0.52104613E 02	-0.65142863E 02	-0.15484248E 03	-0.15484241E 03				
MAG	5- 8	0.19190548E-00	0.41015550E-00	0.13926572E-00	0.86533600E 01				
PHA		-0.51549301E 02	-0.61229800E 02	-0.52403796E 02	-0.15484245E 03				

FREQ = 0.10240000E 03

		NODES				NODE VOLTAGES			
MAG	1- 4	0.79905955E-01	0.72270773E-01	0.92811273E 01	0.92436763E 01				
PHA		-0.52305789E 02	-0.77156746E 02	-0.16700297E 03	-0.16700295E 03				
MAG	5- 8	0.10489667E-00	0.22138733E-00	0.79568193E-01	0.92694430E 01				
PHA		-0.70263936E 02	-0.68569621E 02	-0.52826514E 02	-0.16700296E 03				

MODIFY  
FREQUENCY=100(4)98F3  
EXECUTE

FREQ = 0.99999999E 02

NODES		NODE VOLTAGES			
MAG	1- 4	0.81396223E-01	0.73921674E-01	0.92701083E 01	0.92327021E 01
PHA		-0.52513401E 02	-0.76850143E 02	-0.16669182E 03	-0.16669179E 03
MAG	5- 8	0.10724716E-00	0.22631206E-00	0.81045180E-01	0.92584382E 01
PHA		-0.69792741E 02	-0.68473229E 02	-0.53026033E 02	-0.16669181E 03

FREQ = 0.39999999E 03

NODES		NODE VOLTAGES			
MAG	1- 4	0.39229669E-01	0.18915925E-01	0.95000089E 01	0.94616748E 01
PHA		-0.26213040E 02	-0.87281664E 02	-0.17734505E 03	-0.17734510E 03
MAG	5- 8	0.27665004E-01	0.67036746E-01	0.38515512E-01	0.94880492E 01
PHA		-0.85600285E 02	-0.56080253E 02	-0.26799357E 02	-0.17734507E 03

FREQ = 0.16000000E 04

NODES		NODE VOLTAGES			
MAG	1- 4	0.34665667E-01	0.47297422E-02	0.95020253E 01	0.94636834E 01
PHA		-0.96634780E 01	-0.91795272E 02	0.17776721E 03	0.17776698E 03
MAG	5- 8	0.64203722E-02	0.37633502E-01	0.33855870E-01	0.94900634E 01
PHA		-0.91749703E 02	-0.24196494E 02	-0.98518427E 01	0.17776714E 03

FREQ = 0.63999999E 04

NODES		NODE VOLTAGES			
MAG	1- 4	0.33453641E-01	0.11581337E-02	0.93025134E 01	0.92649767E 01
PHA		-0.12159725E 02	-0.10017825E 03	0.16802720E 03	0.16802626E 03
MAG	5- 8	0.16938418E-02	0.34263654E-01	0.32853332E-01	0.92908027E 01
PHA		-0.10166661E 03	-0.16084793E 02	-0.12205043E 02	0.16802691E 03

FREQ = 0.2560000CF 05

NODES		NODE VOLTAGES			
MAG	1- 4	0.26234575E-01	0.22583416E-03	0.72031499E 01	0.71740842E 01
PHA		-0.34127139E 02	-0.12362528E 03	0.13922098E 03	0.13921721E 03
MAG	5- 8	0.32793023E-03	0.26588344E-01	0.25610354E-01	0.71940818E 01
PHA		-0.12996284E 03	-0.35200594E 02	-0.34132287E 02	0.13921981E 03

FREQ = 0.10240000E 06

NODES		NODE VOLTAGES			
MAG	1- 4	0.10696360E-01	0.23024236E-04	0.26466995E 01	0.26360209E 01
PHA		-0.47406790E 02	-0.13726057E 03	0.10606957E 03	0.10605447E 03
MAG	5- 8	0.30162822E-04	0.10811292E-01	0.10443719E-01	0.26433679E 01
PHA		-0.16077140E 03	-0.47955360E 02	-0.47387446E 02	0.10606488E 03

MODIFY  
FREQUENCY=100E3(2)47F6  
EXECLTE

FREQ = 0.99999999E 05

		NCDES	NODE VOLTAGES			
MAG	1-	4	0.10881639E-01	0.23985025E-04	0.27051424E 01	0.26942278E 01
PHA			-0.47582083E 02	-0.13743322E 03	0.10643865E 03	0.10642391E 03
MAG	5-	8	0.31567102E-04	0.10999659E-01	0.10424544E-01	0.27017372E 01
PHA			-0.16047467E 03	-0.48132172E 02	-0.47563134E 02	0.10643407E 03

FREQ = 0.20000000E 06

		NCDES	NODE VOLTAGES			
MAG	1-	4	0.70534290E-02	0.77757490E-05	0.13955137E 01	0.13898850E 01
PHA			-0.37341851E 02	-0.12725046E 03	0.98261124E 02	0.98231626E 02
MAG	5-	8	0.81746005E-05	0.71019799E-02	0.68887670E-02	0.13937577E 01
PHA			-0.16559201E 03	-0.37847707E 02	-0.37315493E 02	0.98251960E 02

FREQ = 0.39999999E 06

		NCDES	NODE VOLTAGES			
MAG	1-	4	0.55837984E-02	0.30787217E-05	0.70345215E 00	0.70061835E 00
PHA			-0.23022410E 02	-0.11296797E 03	0.93886945E 02	0.93827954E 02
MAG	5-	8	0.20930562E-05	0.55994792E-02	0.54550592E-02	0.70256798E 00
PHA			-0.16395189E 03	-0.23394836E 02	-0.23000559E 02	0.93868619E 02

FREQ = 0.79999999E 06

		NCDES	NODE VOLTAGES			
MAG	1-	4	0.51419487E-02	0.14177517E-05	0.35245027E-00	0.35103758E-00
PHA			-0.12534908E 02	-0.10250553E 03	0.91413754E 02	0.91295779E 02
MAG	5-	8	0.55587259E-06	0.51463030E-02	0.50241101E-02	0.35200936E-00
PHA			-0.15517154E 03	-0.12749983E 02	-0.12521905E 02	0.91377103E 02

FREQ = 0.16000000E 07

		NODES		NODE VOLTAGES			
MAG	1-	4	0.50244781E-02	0.69271170E-06	0.17631731E-00	0.17562484E-00	
PHA			-0.68343458E 01	-0.96819259E 02	0.89641797E 02	0.89405923E 02	
MAG	5-	8	0.16680225E-06	0.50256713E-02	0.49095478E-02	0.17610094E-00	
PHA			-0.13891519E 03	-0.69463742E 01	-0.68275206E 01	0.89568517E 02	

FREQ = 0.31999999E 07

		NODES		NODE VOLTAGES			
MAG	1-	4	0.49934034E-02	0.34421779E-06	0.88173144E-01	0.87855329E-01	
PHA			-0.43378817E 01	-0.94330221E 02	0.87690546E 02	0.87219385E 02	
MAG	5-	8	0.62240741E-07	0.49937820E-02	0.48792411E-02	0.88073329E-01	
PHA			-0.11986873E 03	-0.43944973E 01	-0.43344271E 01	0.87544142E 02	

FREQ = 0.63999999E 07

		NODES		NODE VOLTAGES			
MAG	1-	4	0.49806108E-02	0.17166847E-06	0.44094252E-01	0.43992104E-01	
PHA			-0.39806153E 01	-0.93976703E 02	0.84588968E 02	0.83651243E 02	
MAG	5-	8	0.27871194E-07	0.49807840E-02	0.48667552E-02	0.44061081E-01	
PHA			-0.10516275E 03	-0.40090102E 01	-0.39788820E 01	0.84297321E 02	

FREQ = 0.12800000E 08

		NODES		NODE VOLTAGES			
MAG	1-	4	0.49672579E-02	0.85438742E-07	0.22059800E-01	0.22120820E-01	
PHA			-0.55917761E 01	-0.95589744E 02	0.78819873E 02	0.76980650E 02	
MAG	5-	8	0.13555177E-07	0.49577792E-02	0.48443309E-02	0.22076325E-01	
PHA			-0.95787312E 02	-0.56060059E 01	-0.55909088E 01	0.78245870E 02	

FREQ = 0.25600000E 08

NODES		NODE VOLTAGES			
MAG	1- 4	0.48758053E-02	0.42014069E-07	0.11054730E-01	0.11298616E-01
PHA		-0.98530692E 01	-0.99851977E 02	0.67758239E 02	0.64349214E 02
MAG	5- 8	0.68382866E-08	0.48759119E-02	0.47643504E-02	0.11126426E-01
PHA		-0.89215167E 02	-0.98602310E 01	-0.98526353E 01	0.66680385E 02

FREQ = 0.51199999E 08

NODES		NODE VOLTAGES			
MAG	1- 4	0.45900360E-02	0.19775819E-07	0.55743287E-02	0.60541371E-02
PHA		-0.18042608E 02	-0.10804198E 03	0.47662676E 02	0.42508867E 02
MAG	5- 8	0.36012533E-08	0.45901323E-02	0.44851134E-02	0.57186734E-02
PHA		-0.83750853E 02	-0.18046279E 02	-0.18042391E 02	0.45964981E 02



NODES		VOLTAGES			
1- 4	0.98462394E 01	0.92714269E 01	0.13160963E 02	0.12473693E 02	
5- 8	0.23697288E 02	-0.51800013E-02	0.98442239E 01	0.92939842E 01	
9- 10	0.13103711E 02	0.12961408E 02			

T = 0.9999996F-06

NODES		VOLTAGES			
1- 4	0.98464821E 01	0.92714268E 01	0.12387142E 02	0.11695328E 02	
5- 8	0.23786819E 02	-0.49108267E-02	0.98444465E 01	0.92941272E 01	
9- 10	0.12325349E 02	0.12221736E 02			

T = 0.1999999F-05

NODES		VOLTAGES			
1- 4	0.98482691E 01	0.92714268E 01	0.11658645E 02	0.10970663E 02	
5- 8	0.23854774E 02	-0.30914545E-02	0.98460864E 01	0.92956724E 01	
9- 10	0.11600682E 02	0.11464603E 02			

T = 0.2999997E-05

NODES		VOLTAGES			
1- 4	0.98494508E 01	0.92714275E 01	0.11105766E 02	0.10420665E 02	
5- 8	0.23906120E 02	-0.18819571E-02	0.98471709E 01	0.92966845E 01	
9- 10	0.11050683E 02	0.10890192E 02			

T = 0.3999994E-05

NODES		VOLTAGES			
1- 4	0.98508728E 01	0.92714275E 01	0.10631614E 02	0.99490780E 01	
5- 8	0.23951691E 02	-0.42974949E-03	0.98484759E 01	0.92979258E 01	
9- 10	0.10579094E 02	0.10396821E 02			

T = 0.4999989E-05

NODES		VOLTAGES			
1- 4	0.98513377E 01	0.92714275E 01	0.10300975E 02	0.96201170E 01	
5- 8	0.23981788E 02	0.78082085E-04	0.98489025E 01	0.92983145E 01	
9- 10	0.10250133E 02	0.10053636E 02			

T = 0.5999984E-05

NODES		VOLTAGES			
1- 4	0.98521334E 01	0.92714275E 01	0.10036411E 02	0.93569901E 01	
5- 8	0.24007225E 02	0.92089176E-03	0.98496326E 01	0.92990089E 01	
9- 10	0.99870047E 01	0.97783557E 01			

T = 0.6999979E-05

NODES		VOLTAGES		
1- 4	0.98522616E 01	0.92714275E 01	0.98476982E 01	0.91691850E 01
5- 8	0.24023513E 02	0.10905266E-02	0.98497504E 01	0.92991079E 01
9- 10	0.97991993E 01	0.95828641E 01		

T = 0.7999972E-05

NODES		VOLTAGES		
1- 4	0.98529601E 01	0.92714275E 01	0.98207664E 01	0.91425133E 01
5- 8	0.24027519E 02	0.18339157E-02	0.98503914E 01	0.92997351E 01
9- 10	0.97725275E 01	0.95540047E 01		

T = 0.8999962E-05

NODES		VOLTAGES		
1- 4	0.98529541E 01	0.92714275E 01	0.98208122E 01	0.91425570E 01
5- 8	0.24027542E 02	0.18726587E-02	0.98503858E 01	0.92997321E 01
9- 10	0.97725712E 01	0.95540506E 01		

T = 0.9999951E-05

NODES		VOLTAGES		
1- 4	0.98517643E 01	0.92714275E 01	0.98219490E 01	0.91434628E 01
5- 8	0.24024597E 02	0.72705746E-03	0.98492941E 01	0.92986539E 01
9- 10	0.97734770E 01	0.95569271E 01		

T = 0.1099994E-04

NODES		VOLTAGES		
1- 4	0.98518203E 01	0.92714275E 01	0.98263016E 01	0.91477937E 01
5- 8	0.24024101E 02	0.82802773E-03	0.98493453E 01	0.92987059E 01
9- 10	0.97778079E 01	0.95614742E 01		

T = 0.1199993E-04

NODES		VOLTAGES		
1- 4	0.98517635E 01	0.92714275E 01	0.98220482E 01	0.91435602E 01
5- 8	0.24024528E 02	0.81598759E-03	0.98492933E 01	0.92986543E 01
9- 10	0.97735743E 01	0.95570289E 01		

T = 0.1299992E-04

NODES		VOLTAGES		
1- 4	0.98524883E 01	0.92714275E 01	0.97993889E 01	0.91211402E 01
5- 8	0.24028061E 02	0.15865564E-02	0.98499584E 01	0.92993093E 01
9- 10	0.97511544E 01	0.95326164E 01		

T = 0.1399991F-04

NODES	VOLTAGES			
1- 4	0.98518A93E 01	0.92714275E 01	0.97840538E 01	0.91057754E 01
5- 8	0.24028213E 02	0.10335445E-02	0.98494089E 01	0.92987610E 01
9- 10	0.97357896E 01	0.95174989E 01		

T = 0.1499990F-04

NODES	VOLTAGES			
1- 4	0.98531505E 01	0.92714275E 01	0.97554855E 01	0.90775874E 01
5- 8	0.24033691E 02	0.23413897E-02	0.98505661E 01	0.92999011E 01
9- 10	0.97076014E 01	0.94860803E 01		

T = 0.1599989F-04

NODES	VOLTAGES			
1- 4	0.98527297E 01	0.92714275E 01	0.97127303E 01	0.90349531E 01
5- 8	0.24036369E 02	0.19689798E-02	0.98501800E 01	0.92995153E 01
9- 10	0.96649669E 01	0.94424483E 01		

T = 0.1699988E-04

NODES	VOLTAGES			
1- 4	0.98528096E 01	0.92714275E 01	0.96852645E 01	0.90076334E 01
5- 8	0.24039070E 02	0.20977259E-02	0.98502535E 01	0.92995859E 01
9- 10	0.96376473E 01	0.94138676E 01		

T = 0.1799987E-04

NODES	VOLTAGES			
1- 4	0.98533887E 01	0.92714275E 01	0.96773224E 01	0.89998522E 01
5- 8	0.24041221E 02	0.27261972E-02	0.98507846E 01	0.93001106E 01
9- 10	0.96298661E 01	0.94047540E 01		

T = 0.1899986E-04

NODES	VOLTAGES			
1- 4	0.98528350E 01	0.92714275E 01	0.96769103E 01	0.89993218E 01
5- 8	0.24039795E 02	0.22224188E-02	0.98502767E 01	0.92996089E 01
9- 10	0.96293356E 01	0.94051707E 01		

T = 0.1999985E-04

NODES	VOLTAGES			
1- 4	0.98522653E 01	0.92714275E 01	0.95807212E 01	0.90029976E 01
5- 8	0.24037903E 02	0.17024279E-02	0.98497538E 01	0.92990921E 01

9- 10 0.96330115E 01 0.94099881E 01

T = 0.2000984E-04

NODES

VOLTAGES

1- 4	0.98528981E 01	0.92714275E 01	0.96812820E 01	0.90036649E 01
5- 8	0.24039169E 02	0.23356676E-02	0.98503346E 01	0.92996643E 01
9- 10	0.96336788E 01	0.94097313E 01		

APPENDIX E

Outline of this Memorandum

- I INTRODUCTION
  - A. Contents of Memo
  - B. Purpose of Memo
- II SECTION I: PROGRAM DESCRIPTION
  - A. Purpose of ECAP
  - B. Three Programs in One
    - 1. DC Analysis Program
    - 2. AC Analysis Program
    - 3. Transient Analysis Program
  - C. Usefulness of ECAP
- III SECTION II: PROGRAMMING SOFTWARE
  - A. Two Forms are used
    - 1. Production Request
    - 2. Fortran Coding Form
  - B. Punch Cards Used
    - 1. Time Cards
    - 2. Comment Cards
      - a. Line Spaces, etc.
      - b. Identification Cards
    - 3. Command Cards
      - a. AC Analysis Card
      - b. DC Analysis Card
      - c. Transient Analysis Card
      - d. Execute Card
      - e. Modify Card
    - 4. Data Cards
      - a. The Standard Branch
      - b. B-Cards
      - c. T-Cards
      - d. M-Cards
      - e. S-Cards
      - f. Source Cards
        - (1) Non-Periodic
        - (2) Periodic
        - (3) Sinusoidal

- g. Use of Data Cards
- h. Continuation Cards
- i. Limitations on Data Cards
- j. Maximum: 50 Nodes
- k. Modified Data Cards
- 5. Solution Control Cards
  - a. For AC Analysis
    - (1) Frequency Card
    - (2) Modified Frequency Card
  - b. For DC Analysis
    - (1) Sensitivity Card
    - (2) Worst Case Card
    - (3) Standard Deviation Card
  - c. For Transient Analysis
    - (1) Time Step Card
    - (2) Output Interval Card
    - (3) Initial Time Card
    - (4) Final Time Card
    - (5) Equilibrium Card
    - (6) Short Card
    - (7) Open Card
    - (8) 1 Error Card
    - (9) 2 Error Card
    - (10) 3 Error Card
- 6. Output Specification Cards
  - a. For AC and DC Analysis
    - (1) Print Node Voltages
    - (2) Print Element Voltages
    - (3) Print Branch Voltages
    - (4) Print Element Currents
    - (5) Print Branch Currents
    - (6) Print Element Power Dissipations
    - (7) Print Miscellaneous Outputs
  - b. For Transient Analysis
    - (1) Print Node Voltages
    - (2) Print Element Currents

#### IV SECTION III: COMPUTING PROCEDURE

- A. Recommended Procedure
- B. Demonstrate Procedure
  - 1. DC Bias Point Analysis
    - a. Draw DC Diagram
    - b. Model Non-Linear Devices
    - c. Document ECAP Data
    - d. Assist Computer Center Personnel

- (1) Have Cards Punched
- (2) Assemble Card Deck
- (3) Fill in Production Log
- (4) Submit Data Cards
- (5) Retrieve Output Data

2. DC Worst Case Analysis
3. AC Analysis (Frequency Response)
4. Transient Analysis (Step Response)

V SUMMARY

- A. Restate Purpose of Memo
- B. Restate Purpose of ECAP

VI REFERENCES

VII FIGURES

VIII APPENDICES