

ADA 035952

12 70

Local, Regional and Large Scale Integrated Networks

Sixth Semiannual Techniques

VOLUME 4

LOCAL AND REGIONAL COMMUNICATION NETWORKS —
TECHNOLOGIES AND ARCHITECTURES

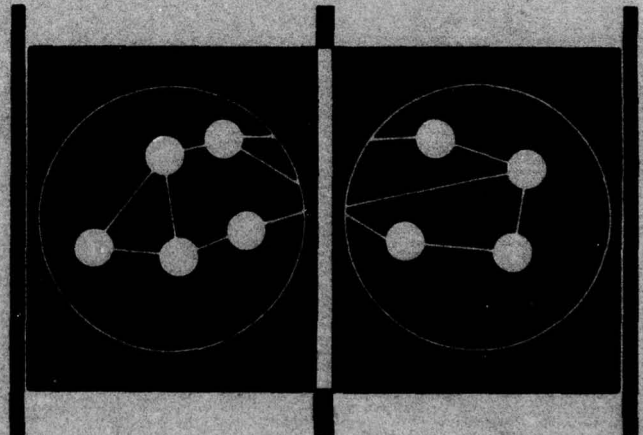

DISTRIBUTION STATEMENT 1
Approved for public release
Distribution Unlimited

DDC
RECEIVED
FEB 24 1977
B

nac

NETWORK ANALYSIS CORPORATION

9
Sixth Semiannual Technical Report . no. 6,
11 February 1976

12 166p.

For the Project

6
Local, Regional and Large Scale Integrated Networks .

VOLUME 4 .

LOCAL AND REGIONAL COMMUNICATION NETWORKS -
TECHNOLOGIES AND ARCHITECTURES .

10
Principal Investigator: Howard Frank,

Co-principal Investigators: Israel/Gitman
Richard/Van Slyke

Contractor

NETWORK ANALYSIS CORPORATION
Beechwood, Old Tappan Road
Glen Cove, NY 11542
(516) 671-9580

✓ ARPA Order # 2286

Contract No. DAHC 15-73-C-0135 ✓

15
Effective Date: 13 October 1972

Expiration Date: 30 June 1977

DISTRIBUTION STATEMENT A

Approved for public release;
Distribution Unlimited

Sponsored by

Advanced Research Projects Agency
Department of Defense

ACCESSION for	
NTIS	White Section <input checked="" type="checkbox"/>
DDC	Buff Section <input type="checkbox"/>
UNANNOUNCED	<input type="checkbox"/>
JUSTIFICATION	
BY	
DISTRIBUTION/AVAILABILITY CODES	
Dist.	AVAIL. and/or SPECIAL
A	

The views and conclusions contained in this document are those of the authors and should not be interpreted as necessarily representing the official policies, either expressed or implied, of the Advanced Research Projects Agency or the U.S. Government.

1473
389161

LB

SIXTH SEMIANNUAL TECHNICAL REPORT

TABLE OF CONTENTS

VOLUME 1

LARGE NETWORKS FOR DEFENSE COMMUNICATIONS: STRATEGIES,
PERFORMANCE MEASURES AND COST TRENDS

VOLUME 2

RECENT ADVANCES IN GROUND PACKET RADIO SYSTEMS

- CHAPTER 1 PACKET RADIO COMMUNICATION PROTOCOLS
- CHAPTER 2 PERFORMANCE EVALUATION OF PACKET RADIO SYSTEMS
- CHAPTER 3 STABILITY CONSIDERATIONS IN PACKET RADIO NETWORKS
- CHAPTER 4 RELIABILITY CONSIDERATIONS IN PACKET RADIO NETWORKS

VOLUME 3

RECENT ADVANCES IN LARGE SCALE INTEGRATED NETWORKS

- CHAPTER 1 LARGE SCALE NETWORK DESIGN: PROBLEM DEFINITION
AND SUMMARY OF RESULTS
- CHAPTER 2 MULTILEVEL NETWORK DESIGN: ALGORITHMS FOR
BACKBONE NODE SELECTION
- CHAPTER 3 IMPACT OF SATELLITE TECHNOLOGY ON THE DESIGN OF
LARGE NETWORKS
- CHAPTER 4 CHANNEL PRIORITIES AND THEIR IMPACT ON NETWORK
DESIGN AND PERFORMANCE

↓
Contents:
↓

VOLUME 4
LOCAL AND REGIONAL COMMUNICATION NETWORKS - TECHNOLOGIES
AND ARCHITECTURES

- CHAPTER 1 ↓ MULTIDROP AND LOOP ALTERNATIVES FOR TERMINAL ACCESS TO A BACKBONE NETWORK - A CASE STUDY,
- CHAPTER 2 ↘ A LOCAL DISTRIBUTION NETWORK USING THE PACKET RADIO TECHNOLOGY - A CASE STUDY,
- CHAPTER 3 ↘ AN URBAN ALTERNATIVE,
- CHAPTER 4 ↘ EXPERIMENTS ON PACKET DATA TRANSMISSION OVER CABLE VIDEO SYSTEMS,
- CHAPTER 5 COMPARISON OF ALTERNATIVE TECHNOLOGIES FOR LOCAL DISTRIBUTION

↑
VOLUME 5
COMPUTATIONAL TECHNIQUES

- CHAPTER 1 SYSTEM FOR AUTOMATIC REMOTE JOB ENTRY
- CHAPTER 2 BACKTRACKING ALGORITHMS FOR NETWORK RELIABILITY ANALYSIS
- CHAPTER 3 EXACT ALGORITHMS FOR NETWORK RELIABILITY ANALYSIS

CONTENTS NOTE
ABSTRACT
B

SUMMARY OF VOLUME 4

TECHNICAL PROBLEM

Network Analysis Corporation's contract with the Advanced Research Projects Agency has the following objectives:

- To determine the feasibility and range of applicability of new technologies for local access to nationwide packet-switched networks. Among these technologies are new configurations of conventional technologies, Packet Radio networks, and Cable Television systems.
- To determine the costs and risk associated with these new technologies.
- To compare the performance and costs of these new technologies.

GENERAL METHODOLOGY

The approach to the problem has been:

- The study of hardware configurations and protocols for Packet Radio and Cable Television systems.

- Experiments have verified that data can be sent on CATV systems at signal levels which do not contribute noticeable interference with commercial video transmission. Video transmission is feasible with negligible bit error rates.
- For the test case the costs of conventional technology, CATV systems and Packet Radio systems with dual homing, range from \$35,000 to \$65,000 per month.
- In the expected price range for hardware both the Packet Radio and CATV technology compare favorably with conventional technology.
- Conventional designs are cost-effective in areas with high population density since multiplexing, multidropping and polling techniques can reduce the cost per terminal.
- With even higher population density CATV systems reduce the cost per terminal since cost of redundant lines can be shared among the terminals.
- In urban areas the system which offers the greatest protection against ingress of noise is the Cable Television system.
- In large areas of relatively high terminal density the Packet Radio is the most economical and offers the added advantage of providing for mobile terminals.

- The experimental verification of data transmission characteristics on CATV systems.
- The application of Packet Radio, Cable Television and conventional techniques to a test case, the Washington, D. C. local area.
- The study of various conventional techniques for the Washington, D. C. local area and for the overall access to a nationwide network.

TECHNICAL RESULTS

The conclusions are:

- At present polling is not a cost-effective local access technique for the Defense Communications environment.
- In the future polling may become viable if certain trends develop, such as the installation of a large number of homogeneous terminals with incorporated polling hardware and logic.
- CATV systems provide the capability to support many thousands of terminals.

DEPARTMENT OF DEFENSE IMPLICATIONS

Many tradeoffs must be considered by DOD in a selecting local access technology. Depending upon the range, topology and population density of the local area one or more of the available technologies can be used. In this report we have outlined the considerations which must be examined in selecting these technologies.

IMPLICATIONS FOR FURTHER RESEARCH

In evaluating local access technologies the risk factor must be considered. The conventional technology is completely predictable, tariff rates are known and hardware is available. The Packet Radio technology is experimental with the first links presently being tested. Cable Television technology is well established and a number of small scale commercial data transmission systems are in operation. However, the technology for handling many thousands of terminals is still in the developmental stage. Further work must be done in modeling these systems as they become operational and in making more precise the tradeoffs considered in this study.

TABLE OF CONTENTS

	<u>PAGE</u>
1. MULTIDROP AND LOOP ALTERNATIVES FOR TERMINAL ACCESS TO A BACKBONE NETWORK - A CASE STUDY	1.1
1.1 General	1.1
1.2 The Model	1.4
1.3 Backbone Network	1.8
1.4 The Star Configuration	1.10
1.5 The Tree + Star Configuration	1.11
1.6 The Loop + Star Configuration	1.15
1.7 Summary and Conclusion	1.19
References	1.22
2. A LOCAL DISTRIBUTION NETWORK USING THE PACKET RADIO TECHNOLOGY - A CASE STUDY	2.1
2.1 Introduction	2.1
2.2 The Packet Radio Technology	2.2
2.3 Design Concepts Utilized in the Case Study	2.5
2.4 Packet Radio Designs for the Case Study	2.9
2.5 Cost Comparison of Conventional and Packet Radio Technologies	2.20
References	2.27
3. AN URBAN ALTERNATIVE	3.1
3.1 Introduction	3.1
3.2 A Typical MATV System	3.4
3.3 A Typical CATV System	3.10
3.4 Data Options on MATV and CATV Systems	3.17
References	3.22

TABLE OF CONTENTS (cont'd)

	<u>PAGE</u>
4. EXPERIMENTS ON PACKET DATA TRANSMISSION OVER CABLE VIDEO SYSTEMS	4.1
4.1 Introduction	4.1
4.2 MATV Tests	4.15
4.3 Modem Tests	4.21
4.4 System Tests	4.24
4.5 Conclusion	4.41
Appendix A: Description of Modem Operation	A.1
Appendix B: Software Operation	B.1
References	4.47
5. COMPARISON OF ALTERNATIVE TECHNOLOGIES FOR LOCAL DISTRIBUTION	5.1

TABLE OF CONTENTSFIGURES

	<u>PAGE</u>
FIGURE 1.1: BACKBONE NETWORK	1.9
FIGURE 1.2: LOCAL ACCESS STRATEGY USING MULTIDROP TREES MODEM SPEED: 1,200 bps	1.13
FIGURE 1.3: LOCAL ACCESS STRATEGY USING MULTIDROP TREES MODEM SPEED: 2,400 bps	1.14
FIGURE 1.4: LOCAL ACCESS STRATEGY USING MULTIDROP LOOPS MODEM SPEED: 1,200 bps	1.18
FIGURE 2.1: LOCATION OF NODES IN CASE STUDY	2.10
FIGURE 2.2: PRNET CONNECTIVITY AND ROUTING FOR PRU TRANS- MISSION RANGE OF 12 MILES	2.16
FIGURE 2.3: PRNET CONNECTIVITY AND ROUTING FOR PRU TRANS- MISSION RANGE OF 16 MILES	2.17
FIGURE 2.4: PRNET CONNECTIVITY AND ROUTING FOR PRU TRANS- MISSION RANGE OF 25 MILES	2.18
FIGURE 2.5: MONTHLY SYSTEM COST FOR ALTERNATIVE DESIGNS ...	2.25
FIGURE 2.6: MONTHLY SYSTEM COST FOR ALTERNATIVE DESIGNS WITH DUAL HOMING RELIABILITY	2.26

TABLE OF CONTENTS
FIGURES (cont'd)

	<u>PAGE</u>
FIGURE 3.1: TYPICAL HOTEL OR APARTMENT BUILDING MATV SYSTEM	3.5
FIGURE 3.2: TYPICAL MOTEL MATV SYSTEM	3.6
FIGURE 3.3: TYPICAL HOME MATV SYSTEM	3.7
FIGURE 3.4: MATV SYSTEM FOR MULTIPLE DWELLING	3.8
FIGURE 3.5: USE OF SINGLE CHANNEL AND BROADBAND AMPLIFIERS FOR RECEIVING DISTANT STATIONS	3.9
FIGURE 3.6: HUB SYSTEM	3.11
FIGURE 3.7: TWO-WAY AMPLIFIER	3.13
FIGURE 3.8: TWO-WAY CATV REPEATER (WITH FEEDERS)	3.14
FIGURE 3.9: DUAL TRUNK/SINGLE FEEDER STATION (SUBURBAN BOSTON CONFIGURATION)	3.15
FIGURE 3.10: NUMBER OF TERMINALS PER TRUNK VS BITS/SEC PER TERMINAL	3.19
FIGURE 3.11: SYSTEM DIAGRAM	3.21
FIGURE 4.1a: SYSTEM LAYOUT 1" = 15'	4.5

TABLE OF CONTENTS
FIGURES (cont'd)

	<u>PAGE</u>
FIGURE 4.1b: FINAL SYSTEM CONFIGURATION	4.6
FIGURE 4.1c: LEGEND FOR SYSTEM CONFIGURATION	4.7
FIGURE 4.2a: IDA45 FREQUENCY RESPONSE	} Following Page 4.18
FIGURE 4.2b: IDA45 PEAK TO VALLEY CHARACTERISTICS	
FIGURE 4.2c: IDA45 SLOPE CHARACTERISTICS	
FIGURE 4.2d: IDA45 INPUT RETURN LOSS	
FIGURE 4.2e: IDA45 OUTPUT RETURN LOSS	
FIGURE 4.3a: TRANSMITTER CLOCK (LOWER SIGNAL) AND SENT DATA (UPPER SIGNAL)	} Following Page 4.22
FIGURE 4.3b: RECEIVER CLOCK (LOWER SIGNAL) AND RECEIVED DATA (UPPER SIGNAL)	
FIGURE 4.3c: SPECTRUM OF MODEM UNMODULATED SIGNAL	Following Page 4.23
FIGURE 4.4a: STANDARD TV CHANNEL SHOWING SOUND-VIDEO CARRIER RELATIONSHIP	4.26
FIGURE 4.4b: CHANNEL 4 SOUND-VIDEO CARRIER RELATIONSHIP ...	4.27

TABLE OF CONTENTS
FIGURES (cont'd)

	<u>PAGE</u>	
FIGURE 4.5a: FULL VIDEO SPECTRUM AND DIGITAL SIGNAL		
FIGURE 4.5b: CHANNELS 2, 4, 5 WITH DATA INTERFERENCE ON CHANNEL 4		
FIGURE 4.5c: CHANNEL 2 WITH DATA ON CHANNEL 6 AND NO FILTER	} Following Page 4.28	
FIGURE 4.5d: CHANNEL 2 WITH NO DATA ON CHANNEL 6 AND CHANNEL 2		
FIGURE 4.6a: MIDBAND AND CHANNELS 7-13 WITH TV CAMERA ON		
FIGURE 4.6b: ZERO BEAT INTERFERENCE RESULTING FROM SPECTRUM IN FIGURE 4.6a		} Following Page 4.29
FIGURE 4.6c: UNMODULATED TV CAMERA SIGNAL ON CHANNEL 8 WITH OFF-THE-AIR CHANNEL 8 TRAPPED AT ANTENNA		
FIGURE 4.7a: MODEM DELAY OF 3.7 μ SEC SENT AND RECEIVED DATA 1 μ SEC/CM		
FIGURE 4.7b: CLEAR-TO-SEND (UPPER SIGNAL) 96 μ SEC AFTER REQUEST-TO-SEND (LOWER SIGNAL) 10 μ SEC/CM	} Following Page 4.33	
FIGURE 4.7c: RECEIVED DATA (UPPER SIGNAL) GOOD 100 μ SEC AFTER RTS (LOWER SIGNAL) 20 μ SEC/CM		

TABLE OF CONTENTS
FIGURES (cont'd)

	<u>PAGE</u>
FIGURE 4.8a: CLEAR-TO-SEND (UPPER SIGNAL) AND REQUEST-TO-SEND (LOWER SIGNAL) 500 μSEC/CM	} Following Page 4.34
FIGURE 4.8b: RECEIVER CLOCK (UPPER SIGNAL) AND TRANSMITTER CLOCK (LOWER SIGNAL)	
FIGURE 4.9a: RECEIVED (UPPER SIGNAL) AND SENT DATA (LOWER SIGNAL) 5000 ONES FOL- LOWED BY 5000 ZEROES, LEADING EDGE OF DATA PATTERN	} Following Page 4.35
FIGURE 4.9b: RECEIVED (UPPER SIGNAL) AND SENT DATA (LOWER SIGNAL) 5000 ONES FOL- LOWED BY 5000 ZEROES, BACK EDGE OF DATA PATTERN	
FIGURE 4.9c: FIRST ONE-BIT (UPPER SIGNAL) AFTER 5000 ZERO BITS AND RECEIVER CLOCK (LOWER SIGNAL)	
FIGURE 4.10: INTERFERENCE OF PACKETS WITH VIDEO SIGNAL WITH REDUCED TV SIGNAL AND BOOSTED DATA SIGNAL	} Following Page 4.36
FIGURE 4.11: % OF PACKETS ERRORS VS DATA SIGNAL LEVEL ON CHANNEL 6	4.39
FIGURE 4.12: MODEM, MINICOMPUTER, INTERFACES AND PAPER TAPE READER	} Following Page 4.41

TABLE OF CONTENTS
FIGURES (concluded)

	<u>PAGE</u>
FIGURE 4.13: GROUPING OF NODES FOR TYPICAL CATV SYSTEMS	4.43
FIGURE 4.A.1: MODEM INTERFACE SIGNALS	A.2
FIGURE 4.A.2: GENERAL BLOCK DIAGRAM	A.4
FIGURE 4.A.3: NAC MODEM BLOCK DIAGRAM	A.5
FIGURE 5.1: TOTAL MONTHLY SYSTEM COST VS UNIT PRICES	5.2

TABLE OF CONTENTSTABLES

	<u>PAGE</u>
TABLE 1.1: COST SUMMARY FOR ALTERNATIVE LOCAL ACCESS CONFIGURATIONS	1.20
TABLE 2.1: TRAFFIC REQUIREMENTS OF NODES IN CASE STUDY ...	2.11
TABLE 2.2: STATION TRAFFIC LOAD	2.14
TABLE 2.3: HARDWARE QUANTITIES FOR PACKET RADIO NETWORK DESIGNS	2.15
TABLE 2.4: APPROXIMATE PAIRWISE DISTANCE MATRIX IN MILES	2.19
TABLE 2.5: SAMPLE EVALUATION FOR PRNET DESIGN 1, ASSUMING PRU PURCHASE PRICE OF \$10,000	2.23
TABLE 2.6: MONTHLY COST OF CONVENTIONAL DESIGNS	2.24
TABLE 4.1: SWEEP FREQUENCY TESTING OF IDA-45 INTERNAL DISTRIBUTION FORWARD AMPLIFIER	4.19
TABLE 4.2: TELEVISION BROADCAST CHANNEL FREQUENCIES	4.28
TABLE 4.3: SYSTEM ERROR RATES	4.38
TABLE 4.4: COST OF DIGITAL CATV EQUIPMENT WITH NO REDUNDANCY	4.45
TABLE 4.5: COST OF DIGITAL CATV WITH REDUNDANCY AND DUAL HOMING	4.46

VOLUME 4

Chapter 1

**MULTIDROP AND LOOP ALTERNATIVES FOR TERMINAL ACCESS
TO A BACKBONE NETWORK: A CASE STUDY**

1. MULTIDROP AND LOOP ALTERNATIVES FOR TERMINAL ACCESS
TO A BACKBONE NETWORK - A CASE STUDY

1.1 GENERAL

In a large, integrated data network, the local access from terminals and Hosts to the high level backbone network can be implemented with a variety of different techniques. Among the alternatives we mention are:

- Dialup.
- Dedicated point-to-point lines.
- Polling on a multidrop circuit or on a loop.
- Time or frequency division multiplexing.
- Concentration (local or remote).
- Distributed ring structure.
- Distributed store-and-forward structure.
- Packet radio broadcast.
- Packet satellite broadcast.
- CATV or MATV, etc.

Of the above alternatives, only a subset is in general feasible for given user requirements (e.g., response time, reliability, security, mobility, etc.). For example, if terminals are mobile or rapidly deployable, radio or satellite broadcast are the only feasible alternatives. In the design phase, the best strategy is selected

from the set of feasible alternatives based on tradeoffs between cost, performance, and growth flexibility.

In this study, we focus on local access alternatives for the proposed AUTODIN II Network, which will integrate more than 30 Defense ADP Systems comprising some 1000 terminals and 100 Host computers. A preliminary study on that system [NAC, 1975A] had compared two local access strategies, namely:

1. Star Connection Strategy: Point-to-point connection between each user site and the nearest backbone switch. Colocated terminals may be clustered, when cost-effective, using TDMX or concentration devices.
2. Intermediate TDMX or Concentration Strategy: This is a refinement of the star strategy, and consists of connecting user sites to intermediate TDMX devices or concentrators rather than directly to the switch, when this results in line cost savings. TDMX and concentration devices are optimally located so as to maximize savings.

The local access design had to satisfy an availability requirement of 99% up time for end-to-end connections. In order to meet such requirement, the intermediate TDMX and concentration devices of Strategy 2 had to be dual homed onto backbone switches. For the Strategy 1, on the other hand, no line backup was required for reliability.

Because of the additional cost of the dual homing requirement, Strategy 2 was less cost-effective than Strategy 1. Thus, the star strategy was proposed for implementation.

In this study, we accept the star strategy as the basic preferred strategy and explore the potential benefits of combining the point-to-point star scheme with a polling scheme, where low traffic

terminals are polled from the backbone switches on multidrop circuits. Polling was not considered in the preliminary study because of the difficulty of implementing security in a polled environment. Although aware of the fact that the polling strategy may not be feasible for the Defense Communications System, we intend to evaluate the savings that such strategy can provide based solely on cost and performance considerations.

Our approach will be that of obtaining a lower bound on the cost of the integrated star and polling strategy (relaxing, if necessary, some of the constraints to simplify the cost evaluation), in order to assess the maximum savings that can be obtained. Should the savings be substantial, a more accurate investigation of feasibility and cost-effectiveness of the polling strategy is in order.

Two alternative configurations for the multidrop circuit are considered:

1. The tree structure, and
2. The loop structure.

While the former configuration provides more cost savings, the latter is more reliable.

In the sequel, we describe the model and evaluate the cost of the two alternatives in the Defense Communications environment.

1.2 THE MODEL

The population of pollable terminals is a subset of the total AUTODIN II terminal population. A pollable terminal satisfies the following requirements:

1. Transmit + Receive traffic \leq 400 bps.
2. The terminal is not at a location served by a concentrator or terminal controller.

The rationale of 1 is that it is more cost-effective to poll terminals with relatively modest traffic requirements. The rationale of 2 is that concentrators and terminal controllers can provide more savings than polling. Based on the above criteria, there are approximately 270 terminals that can be polled.

Since the terminals will, in general, be incompatible from the point of view of line speed, line discipline, protocols, etc., we assume that each terminal is equipped with a standard interface to the multidrop circuit (typically a buffer and a polling selector). The purchase price of the interface is assumed to be around \$2000, based on comparable commercial offerings. Assuming an installation charge of 20% of the base purchase price, a monthly maintenance charge of 1% of the base purchase price, and an amortization over 10 years with 10% yearly interest, the monthly cost of the device is \$50.

For the cost evaluation of star, tree and loop topologies, we assume a uniform mileage cost of \$2/mile x mo. This is a realistic average between high and low density tariff for voice grade lines.

Two types of modems are considered in the design:

1. The 1200 bps asynchronous modem, with a monthly cost of \$25.

2. The 2400 bps synchronous modem with a monthly cost of \$50.

The higher speed option generally allows more traffic (and thus more drops) on the multidrop circuit. This implies higher line cost savings, at the expense of higher modem costs.

In order to be consistent with the star local access design, in which line downtime was assumed .4%, we assume that each segment of the multidrop circuit can fail with probability .4%, and that failures of different segments on the same circuit are independent. We assume that terminal failures have the effect of leaving the line open in correspondence to the drop. We assess this terminal failure probability to be also .4%.

Based on the above data, we calculate the availability of terminals on tree and loop configurations.

For a tree of depth N , (i.e., N hierarchical levels) the availability A (defined as the probability that all the operating terminals can communicate with the backbone switch) is bounded as follows:

$$A \geq (.996)^{2N}$$

Thus, for $N = 5$, $A \geq .960$, and, for $N = 10$, $A \geq .923$.

For a loop with N drops, the availability A is bounded by the following expression:

$$\begin{aligned} A &\geq (.996)^{2N+1} + (2N+1) \times .004 \times (.996)^{2N} \\ &= (.996)^{2N} \times [.996 + (2N+1) \times .004] \end{aligned}$$

The table below shows the lower bound on A as a function of N , for $N \leq 10$.

N	A
2	.99984
3	.99966
4	.99943
5	.99913
6	.99878
7	.99837
8	.99790
9	.99738
10	.99680

Recalling that for AUTODIN II, the end-to-end availability must be $\geq .99$, we conclude that this requirement is comfortably met with loop configurations with $N < 10$, while it cannot be met with tree configurations with $N \geq 2$. Therefore, dial up back up must be provided in the tree implementation in order to obtain an acceptable level of reliability.

Defense Communications System requirements specify that the delay from terminal to backbone switch on a polled circuit be ≤ 1 sec. This delay constraint translates into a constraint on the total volume of transmit and receive traffic allowed on each circuit. Assuming that the average message length from terminal to backbone switch is 72 characters (e.g., one line of a CRT display), and assuming that sequential polling is used, it is found that the total traffic volume must be ≤ 400 bps for a 1200 bps circuit, and ≤ 1200 bps for a 2400 bps circuit.

The number of drops on the circuit also has an impact on response delay, because of the latency delay term which is linear with the number of drops. The above limits on total traffic were calculated assuming 10 drops on the circuit.

In the design of multidrop trees and loops, we will use the following constraints:

1. Number of drops \leq 10.
2. Traffic volume (sum of transmit + receive traffic):
 \leq 400 bps for a line speed of 1200 bps.
 \leq 1200 bps for a line speed of 2400 bps.

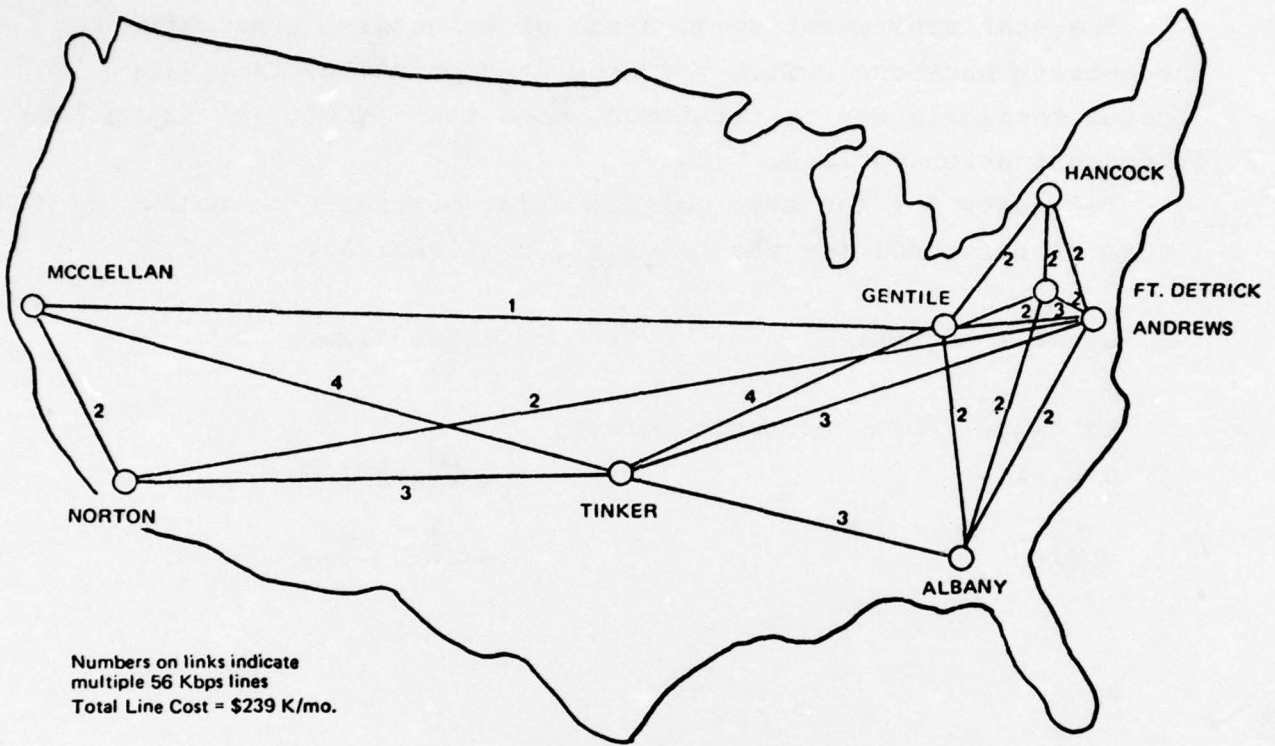

FIGURE 1.1: BACKBONE NETWORK

1.4 THE STAR CONFIGURATION

The star configuration consists of connecting user sites to the nearest backbone switch via dedicated point-to-point line. Co-located terminals may be clustered, when cost-effective, using TDMX or concentration devices.

The costs for the star configuration are reported below, as a term of reference for the other alternatives:

Lines + modems:	\$360,811/mo.
Hardware (TDMX, concentrators, etc.):	<u>\$ 85,898/mo.</u>
TOTAL	\$446,709/mo.

1.5 THE TREE + STAR CONFIGURATION

The terminals that can be polled are connected to backbone nodes via low cost multidrop trees. The remaining terminals are star connected to backbone nodes.

The assignment of pollable terminals to backbone nodes and the tree layout are both obtained with the Unified Algorithm, a very efficient tool for multipoint network design [CHOU, 1973]. The maximum number of drops allowed per circuit is 10. The maximum traffic volume allowed per circuit is 400 bps or 1200 bps depending whether 1200 bps or 2400 bps modem alternative is considered.

The costs of the various network components are the following:

1. Star Subnetwork Cost:

Lines + modems:	\$284,796/mo.
Hardware (TDMX, concentrators, etc.):	<u>\$ 78,692/mo.</u>
TOTAL STAR COST	\$363,488/mo.

2. Multidrop Subnetwork Cost: (1200 bps modem alternative)

Lines + modems:	\$ 50,070/mo.
Interface devices:	<u>\$ 13,600/mo.</u>
TOTAL MULTIDROP COST	\$ 63,670/mo.

3. Multidrop Subnetwork Cost:
(2400 bps modem alternative)

Lines + modems:	\$ 41,776/mo.
Interface devices:	<u>\$ 13,600/mo.</u>
TOTAL MULTIDROP COST:	\$ 55,376/mo.

The total cost for the 1200 bps modem configuration is \$427,158/mo. The total cost for the 2400 bps modem configuration is \$418,864/mo. The introduction of higher speed modems (2400 bps) is therefore beneficial in terms of line cost savings. However, additional cost factors such as the cost of the I/O interface at the switch and the cost of the buffer and selector device (which may differ for different line speeds) should be considered for a finer comparison of modem alternatives.

The multidrop tree configuration with up to 10 drops is not sufficiently reliable. Therefore, dial up back up equipment must be provided for each drop and dial up ports must be made available at the switches.

Figures 1.2 and 1.3 show the tree topologies for the local access to the AUTODIN II switches for 1200 bps and 2400 bps modem options, respectively.

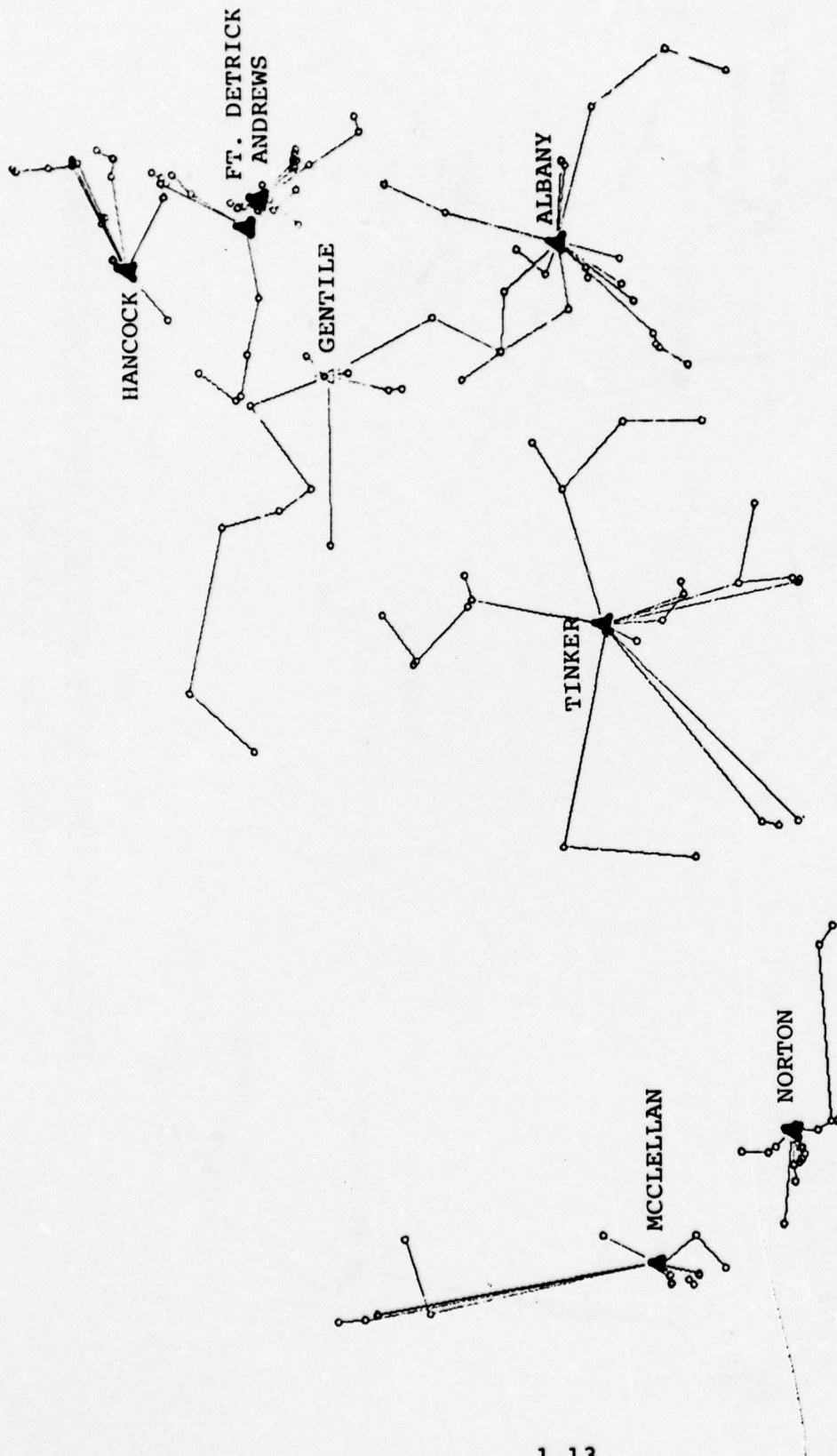

FIGURE 1.2 LOCAL ACCESS STRATEGY USING MULTIDROP TREES

MODEM SPEED: 1,200 bps

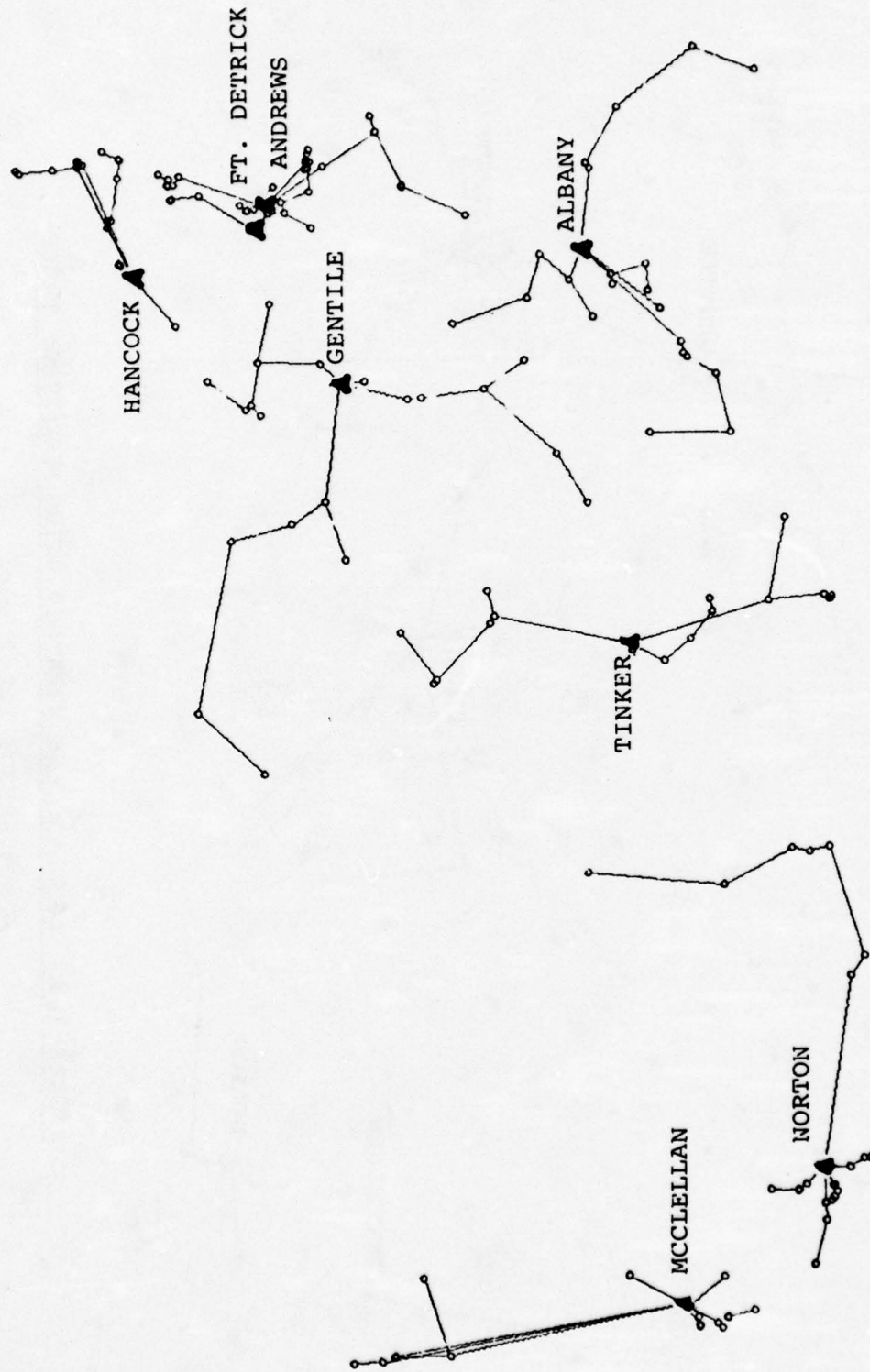

FIGURE 1.3: LOCAL ACCESS STRATEGY USING MULTIDROP TREES

MODEM SPEED: 2,400 bps

1.6 THE LOOP + STAR CONFIGURATION

In this strategy, pollable terminals are connected to a switch with a multipoint loop. The remaining terminals are connected to the switches via a star configuration.

The loop has two terminations (interfaces) connected to the switch. Only one interface is used during normal conditions (no loop failures) to poll the terminals from the switch while the other remains inactive. In this case, operations are exactly as in the standard multidrop technique. When a failure along the loop occurs, which makes some of the terminals inaccessible from the primary interface, communications between the switch and the disconnected section of the loop are re-established through the secondary interface.

The design of the low cost loop configuration consists of two steps:

1. Partitioning of pollable terminals into sets, each set associated to a backbone switch.
2. Low cost loop layout with constraints on the number of drops and on traffic volume. The loop design is performed with a computer program based on a modified Clark-Wright algorithm [NAC, 1975B].

No more than 10 drops are allowed on each loop in order to maintain adequate reliability. Traffic volume for each loop must be ≤ 400 bps (if 1200 bps modems are used) or ≤ 1200 bps (if 2400 bps modems are used).

Network costs are summarized below:

1. Star Subnet:

Lines + modems:	\$284,796/mo.
Hardware (TDMX, concentrators, etc.):	<u>\$ 78,692/mo.</u>
TOTAL	\$363,488/mo.

2. Loop Subnet:
(1200 bps modem alternative)

Line cost:	\$ 45,000/mo.
Modem cost:	\$ 8,550/mo.
Buffers and selectors:	<u>\$ 13,600/mo.</u>
TOTAL	\$ 67,150/mo.

3. Loop Subnet:
(2400 bps modem alternative)

Line cost:	\$ 33,750/mo.
Modem cost:	\$ 15,600/mo.
Buffers and selectors:	<u>\$ 13,600/mo.</u>
TOTAL	\$ 62,950/mo.

The total local access cost is therefore \$430K/mo for the loop system with 1200 bps modems. It is \$425/mo for the loop system with 2400 bps modems.

Figure 1.4 shows the loop configuration with 1200 bps modems.

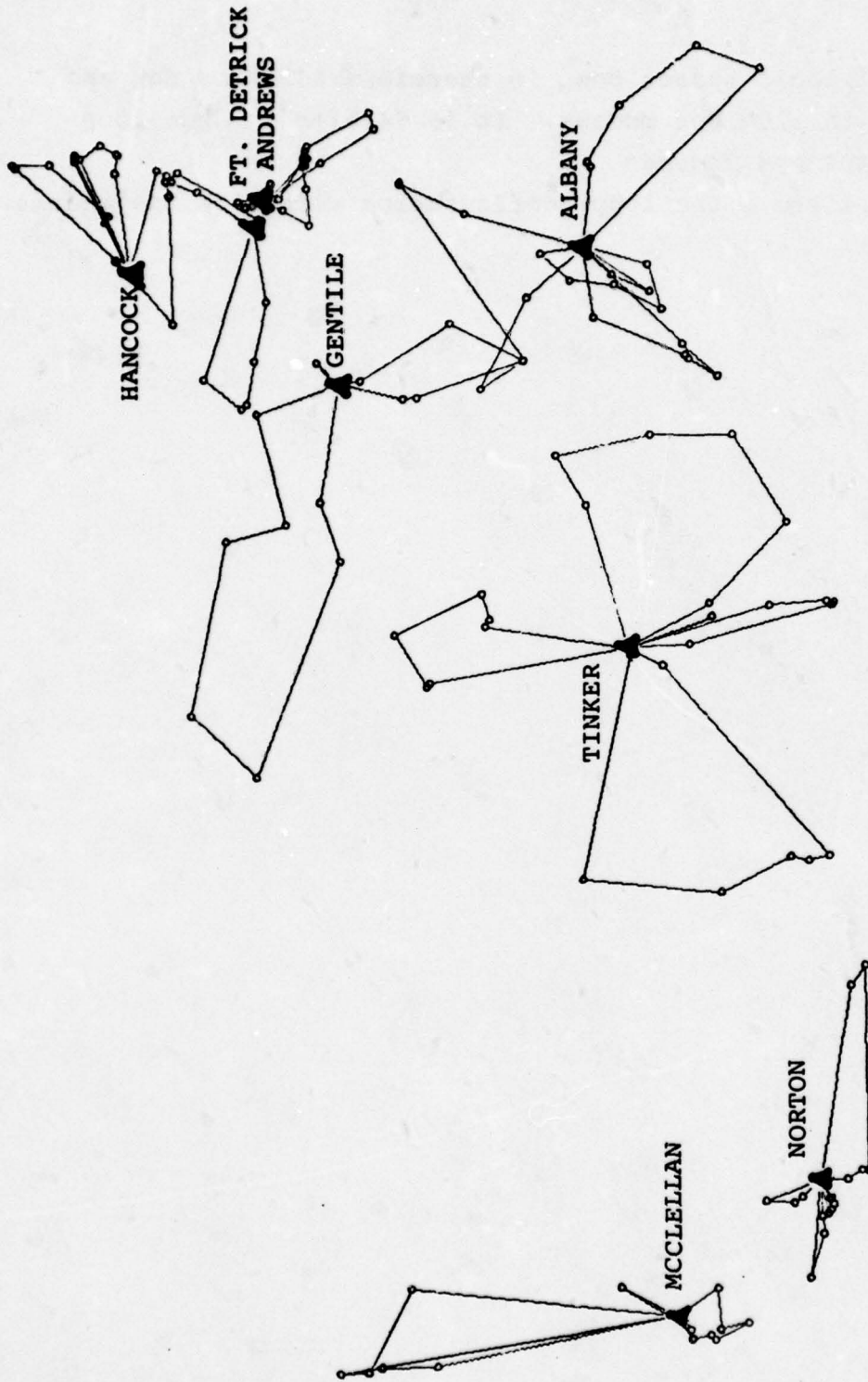

FIGURE 1.4: LOCAL ACCESS STRATEGY USING MULTIDROP LOOPS

MODEM SPEED: 1,200 bps

1.7 SUMMARY AND CONCLUSION

Table 1.1 summarizes the results of this study. The lowest cost strategy is the star + multidrop tree configuration using 2400 bps modems. We recall however that the tree structure is not sufficiently reliable, and that it requires dial up back up to meet the Defense Communications standards. The cost of providing dial up back up at 270 terminals and reserving an appropriate number of dial up ports at the backbone switches is not evaluated here, but will most likely exceed the cost difference between tree strategy and loop strategy, which is approximately \$7,000/mo.

Recalling that loops do not require dial up back up for reliability, we conclude therefore that the loop strategy is (cost-wise) the most attractive among the polling alternatives.

The cost savings obtained with the hybrid star and loop configuration with respect to the basic star configuration is \$21,000/mo, i.e., 5% of the total local access cost. This figure is actually an upper bound on the savings, considering the various assumptions made in this study. For a more accurate cost appraisal further investigation is required in the following areas:

1. Cost of polling software implementation in the switch.
2. Cost of providing security.
3. Cost of buffers and selectors to allow a standard polling procedure.
4. Failure characteristics on a multidrop circuit.
(Note: our assumption of independence between failures on different segments is not very conservative and may lead to loop reliability results better than the performance in the actual implementation.)

	<u>LINE + MODEM</u>	<u>HARDWARE</u>	<u>TOTAL</u>
Star Configuration	\$360K/mo	\$85K/mo	\$446K/mo
Star + Multidrop Tree Configuration (1200 bps modems)	335	92	427
Star + Multidrop Tree Configuration (2400 bps modems)	326	92	418
Star + Multidrop Loop Configuration (1200 bps modems)	339	92	430
Star + Multidrop Loop Configuration (2400 bps modems)	334	92	425

TABLE 1.1: COST SUMMARY FOR ALTERNATIVE LOCAL ACCESS CONFIGURATIONS

To conclude, the tradeoff between the marginal cost saving of 5% and the elements of potential technical risk and unknown cost mentioned in points 1 and 2 previously indicate that polling is not a cost-effective local access technique for the present Defense Communications environment. In the future, the polling alternative may become viable if some of the following trends develop in the Defense requirements:

1. Installation of a large number of homogeneous (compatible) terminals with incorporated polling hardware and logic.
2. Existence of a large number of isolated terminals, for which polling is more cost-effective than remote concentration or TDMX.
3. No security requirements for a large number of terminals.

REFERENCES

- [NAC, 1975A] Network Analysis Corporation, Alternative Network Strategies For Defense ADP Communications, July 1975.
- [CHOU, 1973] Chou, W. and A. Kershenbaum, "A Unified Algorithm for Designing Teleprocessing Networks," Data Networks: Analysis and Design, Third Data Communications Symposium, St. Petersburg, Florida, November 13-15, 1973, pp. 148-156.
- [NAC, 1975B] Network Analysis Corporation, "Capacitated Minimum Spanning Loop Design Algorithms," Internal Memorandum WM.033.02, September 1975.

VOLUME 4

Chapter 2

**A LOCAL DISTRIBUTION NETWORK USING
THE PACKET RADIO TECHNOLOGY – A CASE STUDY**

2. A LOCAL DISTRIBUTION NETWORK USING THE PACKET RADIO TECHNOLOGY - A CASE STUDY

2.1 INTRODUCTION

In this chapter we apply the Packet Radio (PR) Technology to a set of computers and terminals of the AUTODIN II network. The objective is to assess the applicability of the PR technology and to obtain a preliminary cost comparison between a conventional communication technology and the PR technology. The PR technology consists of interfacing radio devices to computers and terminals and using a broadcast radio channel for connecting the set of computers and terminals. The conventional technology used as a basis for comparison consists of concentrators and multiplexers for connecting low speed terminals and computers to a backbone network in a point-to-point configuration.

The Washington, D.C. area was used for the case study. The area covers a rectangle of approximately 80 by 100 miles and contains a set of 20 Host computers and 109 terminals.

This case study is preliminary in several aspects. Firstly, the PR technology has not yet been extensively tested, and its devices have not been produced on a commercial basis. Therefore, the performance of the Packet Radio Network, PRNET, assumed in this study, is based on analytical results [KLEINROCK, 1975; GITMAN, 1975] and extensive simulation studies of performance [FRANK, 1975; NAC, 1976A]. The cost of communication devices is parametrized.

Secondly, computer programs have not yet been developed for PRNET design; hence, there is no claim of optimality or minimum cost design. However, the assumptions about the performance of the PR communication devices are stated, so that one can examine the impact of the various assumptions on the design and infer on cost changes when some of the assumptions are modified.

2.2 THE PACKET RADIO TECHNOLOGY

The PR technology was primarily developed to address communication requirements of applications for which the present conventional technology is not particularly suitable [KAHN, 1975], and to provide more efficient techniques for frequency spectrum utilization. However, it became apparent that this technology can compete with conventional technologies on an economic basis for certain types of applications. The PR technology is particularly suitable for applications in which:

- a. Resources (e.g., terminals, computers) are mobile, so that a broadcast mode is necessary.
- b. Resources are located in remote or hostile locations where hardwire connections are uneconomical or not feasible.
- c. The traffic characteristics are of a bursty nature; that is, there is a high ratio of peak bandwidth to average bandwidth requirements.

The main features which distinguish the Packet Radio System from a point-to-point packet switching system (such as the ARPANET) are:

1. Devices in the system transmit packets by using a random access scheme, and
2. Devices broadcast so that packets can be transmitted to several devices simultaneously, and/or several packets can be simultaneously received by a

receiver because of independent transmissions of several devices. These features have a major impact on practically every aspect of network design.

The hardware of the PR technology is based on the Packet Radio Unit (PRU), which consists of a microprocessor with associated electronics and a radio transceiver [GARRETT, 1975]. The applications software of the technology consists of a set of novel techniques for dynamic sharing of the communication channels, for efficient and reliable packet transportation, for network initialization and reconfiguration, and techniques for real time diagnosis and control of programs and parameters in the PRU's.

There are three basic functional components of the Packet Radio System: the Packet Radio Terminal, the Packet Radio Station, and the Packet Radio Repeater. The PR Terminal consists of a common type terminal or computer interfacing to a PRU. The Repeater is a stand-alone PRU which operates as a relay switching node and provides radio connectivity to interconnect communication devices within the radio net and/or to connect to a gateway into another network. In applications in which terminals are mobile, the Repeater is considered as an area coverage device [NAC, 1974]. The PR Station consists of a minicomputer interfacing to a PRU. The Station performs such functions as PRU initialization, connectivity monitoring, global stability control functions, accounting, buffering, and directory functions for radio communication devices. When the PRNET interfaces with other networks, the Station performs the gateway functions [BURCHFIEL, 1975].

An experimental PRNET will be extensively tested during 1976 in the San Francisco area. In the present implementation, a PRU has two channels of 100 Kb/s and 400 Kb/s. The low data rate channel is used for communication between a terminal and a repeater or

a station, and the high data rate channel is used in the Repeater-Station Network. The PRU is powered by batteries and can transmit at several power levels resulting in several radio connectivity ranges. The present routing algorithm [GITMAN, 1976] implies a centralized store-and-forward architecture, in which communication between two terminals proceeds via a station.

2.3 DESIGN CONCEPTS UTILIZED IN THE CASE STUDY

There are several aspects by which the communication requirements for the case considered differ from those for which the PR technology was developed. Specifically, terminals and Hosts are not mobile, terminals and/or Hosts are colocated, the PRU or its transceiver can be placed on elevated areas, and PRU's have access to (practically) unlimited electrical power sources.

In applying the PR technology one can take advantage of the above observations; the major implications of which will be the following:

1. There is no need to interface each terminal or Host computer with a PRU. A PRU can serve as a front-end to several colocated Hosts and/or terminals.
2. A PRU can perform two functions simultaneously; operate as a front-end to a set of terminals and at the same time perform the relay functions of a repeater, providing its throughput capacity is sufficient.
3. The freedom in placing the PRU and the availability of electrical power enables the PRU to have a larger effective transmission range than in general deployment conditions.

It may be of interest to note that other results which may reduce cost and improve performance are available. In the reference, GITMAN, 1975, it is shown that directional antennas at stations may significantly increase PRNET capacity. In GITMAN, 1975, an efficient routing algorithm which enables direct PRU

to PRU packet transportation without the need to go through the station was proposed. This algorithm is particularly useful for applications of the type considered in which devices are not mobile and in which some of the origination and destination process pairs are on the radio network. The above and other available results are not utilized in this preliminary case study.

The 20 Host computers and 109 terminals in the 8000 square miles area for which the PRNET is designed are located in 25 different locations. Two of these locations contain backbone switching nodes which interface to a higher level network. We refer to a location as a node. A node includes a terminal, a Host computer, or a combination of terminals and Hosts.

The following assumptions and guidelines are used in the design.

1. Only the high data rate of 400 Kb/s will be used by the transceivers. That is, since terminals and Hosts are not mobile they will be interfaced to a PRU or Station minicomputer with a hardwired connection.
2. Two assumptions related to the number of ports to which communication devices can interface, are used:
 - a. All devices in a node can interface to a PRU.

b. At most 3 devices can interface to a PRU. Hence, if a node contains 4 or more devices, a station is provided. This station does not perform any of the control and initialization functions; its only use is to interconnect the set of terminals and/or Hosts, (Radio Concentrator, or Radio front end).

3. We assume three different effective transmission distances for a PRU: 12 miles, 16 miles, and 25 miles. The justification for the long transmission range has been discussed before; however, it appears that this is not a significant cost factor when the reliability (connectivity) requirement is low.

4. From the reliability point of view, the only requirement assumed is that every node must have a radio communication path to both backbone nodes. In the designs presented, no requirement for two (or more) independent radio paths from each node to a backbone node was used. However, in the comparison with conventional designs we state the additional hardware needs and evaluate the costs for such requirements.*

5. The maximum throughput (or the capacity) of a single station PRNET is assumed to be 25% of the channel data rate, namely 100 Kb/s. Analytical results for a single hop network in which PRU's use the non-persistent carrier sense access scheme [KLEINROCK, 1975] and for a 2-hop network in which devices use the slotted ALOHA random access scheme [GITMAN, 1975], show much higher capacity

* No reliability analysis is done in this chapter. The reader may consult reference [NAC, 1976B] for reliability analysis of PRNET's with one and two stations.

values. On the other hand multihop simulation results with overhead related to mobility demonstrate lower capacity values [NAC, 1976A].

6. It is assumed that all traffic requirements from a node are routed toward a Backbone node and the traffic to each node is routed from the Backbone node. This assumption overestimates the traffic since some of these requirements are local.

2.4 PACKET RADIO DESIGNS FOR THE CASE STUDY

Figure 2.1 shows the location of nodes considered in the case study; the nodes are categorized by the type of devices they contain. In Table 2.1 we list the number and type of devices that each node contains and the traffic requirements of each node.

The design needs to satisfy capacity requirements and connectivity requirements. It is first noted that the traffic of backbone nodes 1 and 12 need not be satisfied by the PRNET. Second, node 7 has the highest traffic requirement, the total of which (73.13 Kb/s) requires a station capacity. Hence, it is decided to connect node 7 to backbone node 1 with two parallel 56 Kb/s full duplex channels. Furthermore, since there are other nodes in the proximity of node 7, it is not needed for relaying functions and therefore no PRU is provided at its location.

The total traffic requirements of the nodes for which the PRNET is provided is 137.2 Kb/s; thus, at least two PR Stations, at a distance apart which prevents radio interference, are needed to satisfy the traffic requirements.

It was a priori decided to place PR Stations at backbone nodes 1 and 12 and to divide the traffic requirements between them to prevent station saturation. No attempt was made to optimize station locations although for example, it may have been more economical to provide a station at node 19 and connect node 19 to 12 by a point-to point channel.

Traffic and distance considerations have led to a partition of the nodes between the stations in the following way; nodes 9, 10, 11, 18, 19, 20, and 21 will be served by the station in backbone node 12, and the traffic requirements of all other nodes will be satisfied by the station in backbone node 1. We shall not describe

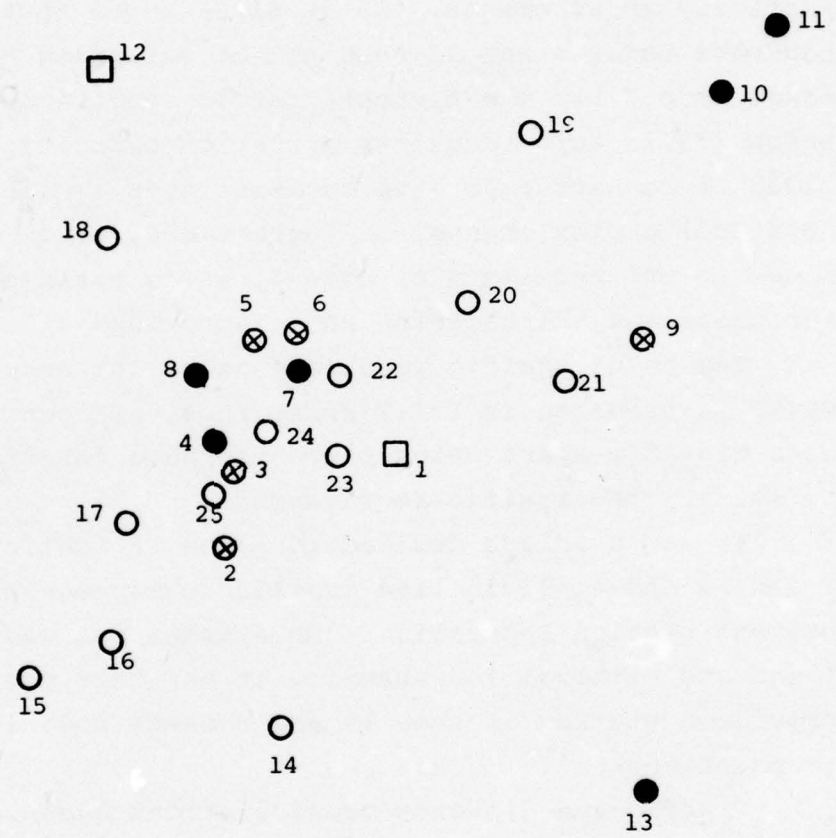

T	○	TERMINAL(S)
H	⊗	HOST(S)
HT	●	HOST (S) AND TERMINAL(S)
BN	□	BACKBONE NODE

FIGURE 2.1: LOCATION OF NODES IN CASE STUDY

NODE	CATEGORY	#H	#T	TRAFFIC IN KB/S (TRANSMIT/RECEIVE)		
				HOST TRAFFIC	TERMINAL TRAFFIC	TOTAL TRAFFIC
1	BN	1	10	29.4 , 24.6	1.303, 8.394	30.703, 32.994
2	H	1		9.85, 0.87		9.85, 0.87
3	H	1		6.8, 0.2		6.8, 0.2
4	HT	2	5	9.61, 5.9	0.82, 3.13	7.43, 9.03
5	H	1		10.4, 2.08		10.4, 2.08
6	H	1		1.33, 0.168		1.33 0.168
7	HT	7	24	40.02, 20.91	1.8, 10.4	41.82, 31.31
8	HT	1	31	2.2, 0.4	0.12, 0.57	2.32, 0.97
9	H	1		5.2, 4.3		5.2, 4.3
10	HT	1	1	13.13, 1.53	0.22, 0.12	13.35, 1.65
11	HT	1	6	12.17, 1.2	0.676, 6.814	12.846, 8.014
12	BN	1		31.24, 24.37		31.24, 24.37
13	HT	1	2	2.5, 0.5	0.007, 0.033	2.507, 0.533
14	T		1		0.004, 0.13	0.004, 0.13
15	T		1		0.002, 0.012	0.002, 0.012
16	T		1		0.29, 1.49	0.29, 1.49
17	T		2		0.22, 1.9	0.22, 1.9
18	T		1		0.004, 0.13	0.004, 0.13
19	T		4		0.18, 0.9	0.18, 0.9
20	T		1		0.004, 0.13	0.004, 0.13
21	T		2		0.006, 0.142	0.006, 0.142
22	T		12		0.059, 0.274	0.059, 0.274
23	T		1		2.7, 2.7	2.7, 2.7
24	T		3		0.13, 0.65	0.13, 0.65
25	T		1		0.22, 0.11	0.22, 0.11

TABLE 2.1: TRAFFIC REQUIREMENTS OF NODES IN CASE STUDY

the detailed considerations which led to this partition. For example, if nodes 5 and 6 were connected to backbone node 12, the transmissions of nodes 5 and 6 using omnidirectional antennas would in any event interfere with backbone node 1. Furthermore, although (as will be seen) the traffic is not equally divided among the stations, multihop PRNET analysis [GITMAN, 1975; NAC, 1976C] show that the traffic bottleneck is not always at the station. Specifically, if nodes 5 and 6 were connected to node 19 via node 20 and then connected to the station at backbone node 12 via a string of stand-alone PRU's, then the station would not be saturated but the PRU in node 19 and the string of PRU's will all be saturated.

We now present the results of the various designs. Six different designs are made based on the combinations of assumptions 2 and 3. Namely, the effective transmission range of a PRU and the number of ports assumed for hardwired connections of terminals and Hosts.

Figures 2.2, 2.3, and 2.4 show the connectivity of the resulting PRNET's for an effective PRU transmission range of 12 miles, 16 miles, and 25 miles, respectively. It is assumed that each node (apart from 7) contains either a PRU or a PR Station. In addition, stand-alone PRU's are added for packet relay purposes to provide radio connectivity to a station for communication purposes and to satisfy the requirement that each node has a radio path to both stations (see, for example, PRU 29 in Figure 2.2). However, one can see that some nodes have only a single path, in particular when PRU transmission range is 12 miles.

It is noted that when one of the stations is down, the remaining station will be traffic saturated if the traffic requirements of nodes are those of the busy hour (the values in Table 2.1). In such event, flow and stability control algorithms of the station will

limit the input traffic rate of low priority messages. Also note, for example, that PRU 27 in Figure 2.4 is placed so that there is no radio connectivity between it and nodes 5 and 6, otherwise PRU 27 may become traffic saturated during peak hour conditions.

The solid lines in Figures 2.2, 2.3, and 2.4, show the paths that will be utilized by each node for communication with its primary station. There are also the minimum hop paths to the primary station and from a partition of the nodes between the two stations for message handling. The PRU's in the network will include routing information which will enable them to transport packets to the primary station (and secondary station) along the path shown in the figures [GITMAN, 1976]. One can see from the above figures that one can model the PRNET as a one or 2-hop network (the Station at node 1) or as a string of repeaters leading to a station (the station at node 12), for obtaining detailed traffic and delay analysis.

Table 2.2 gives the traffic rates at the two stations and the effective utilization of the channel at the station PRU. These values are the same for all the designs, since the partition of the nodes between the stations is fixed. Note also that the two stations are connected through a point-to-point network for which they perform the gateway functions. Table 2.3 gives the quantities of PRU's and Stations for the six designs. The cost of the designs is parametrized and compared with conventional technology designs in the next section. The approximate pairwise distance matrix of nodes is given in Table 2.4.

	TRAFFIC TO STATION [Kb/s]	TRAFFIC FROM STATION [Kb/s]	TOTAL TRAFFIC [Kb/s]	EFFECTIVE UTILIZATION OF CHANNEL AT STATION
Station at Node 1	50.4	40.1	90.5	22.6%
Station at Node 12	31.6	15.1	46.7	11.7%

TABLE 2.2: STATION TRAFFIC LOAD

PRU TRANSMISSION RANGE [miles] PRU PORTS TOTAL NUMBER OF PRU'S TOTAL NUMBER OF PR STATIONS

Design 1	12	No Limit	30	2
Design 2	16	No Limit	27	2
Design 3	25	No Limit	24	2
Design 4	12	3	25	7
Design 5	16	3	22	7
Design 6	25	3	19	7

TABLE 2.3: HARDWARE QUANTITIES FOR PACKET RADIO NETWORK DESIGNS*

* The station is composed of a minicomputer (presently a PDP 11/45), interfacing with a PRU, as defined in Section 2. Thus, N (PRU's) and M (stations) are equivalent to (N+M) (PRU's) and M (minicomputers) and M (interfaces).

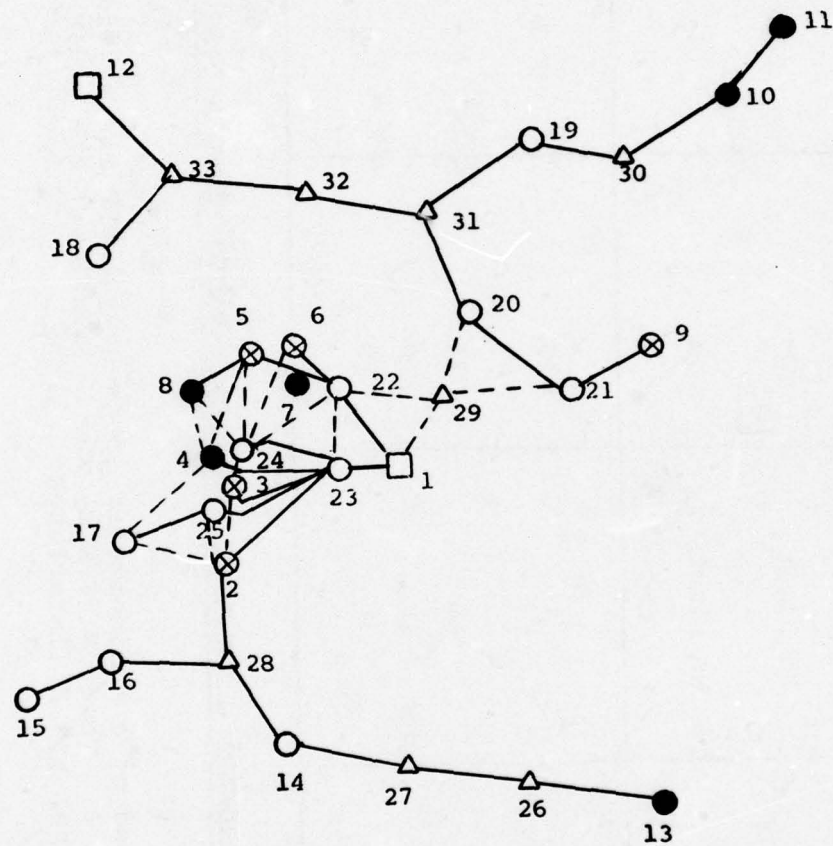

T	○	TERMINAL(S)	—————	RADIO LINK FOR ROUTING
H	⊗	HOST(S)	-----	OTHER RADIO LINKS
HT	●	HOST (S) AND TERMINAL(S)		
BN	□	BACKBONE NODE		
PR	△	PACKET RADIO UNIT (REPEATER)		

FIGURE 2.2: PRNET CONNECTIVITY AND ROUTING FOR PRU TRANSMISSION RANGE OF 16 MILES

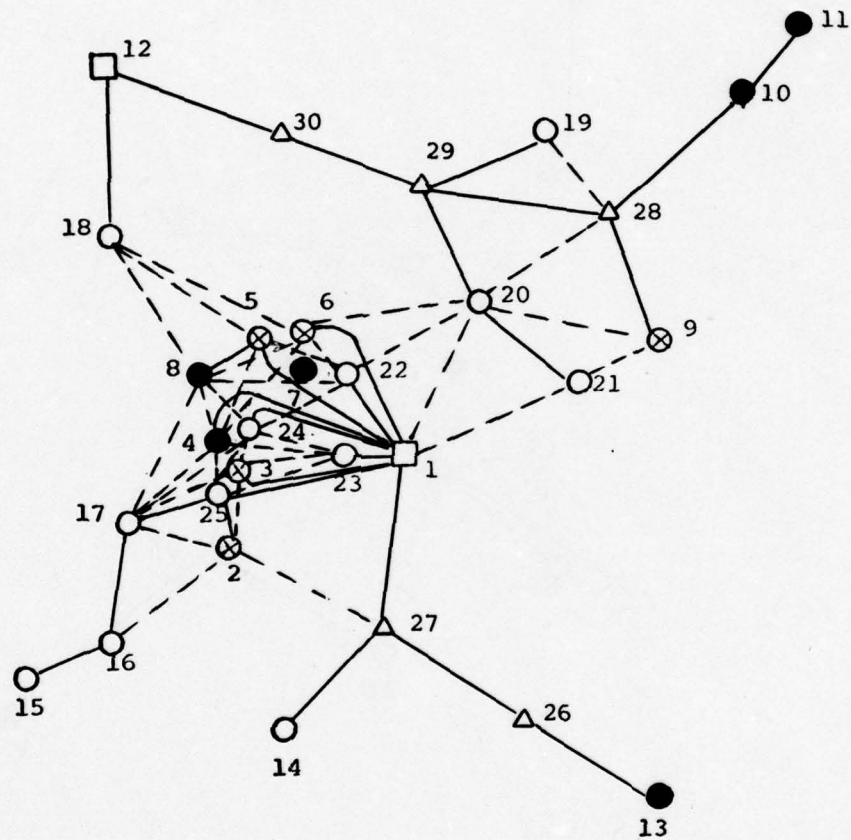

- | | | | | |
|----|---|------------------------------|-------|-------------------------|
| T | ○ | TERMINAL(S) | ————— | RADIO LINKS FOR ROUTING |
| H | ⊗ | HOST(S) | ----- | OTHER RADIO LINKS |
| HT | ● | HOST(S) AND TERMINAL(S) | | |
| BN | □ | BACKBONE NODE | | |
| PR | △ | PACKET RADIO UNIT (REPEATER) | | |

FIGURE 2.3: PRNET CONNECTIVITY AND ROUTING FOR PRU TRANSMISSION
RANGE OF 25 MILES

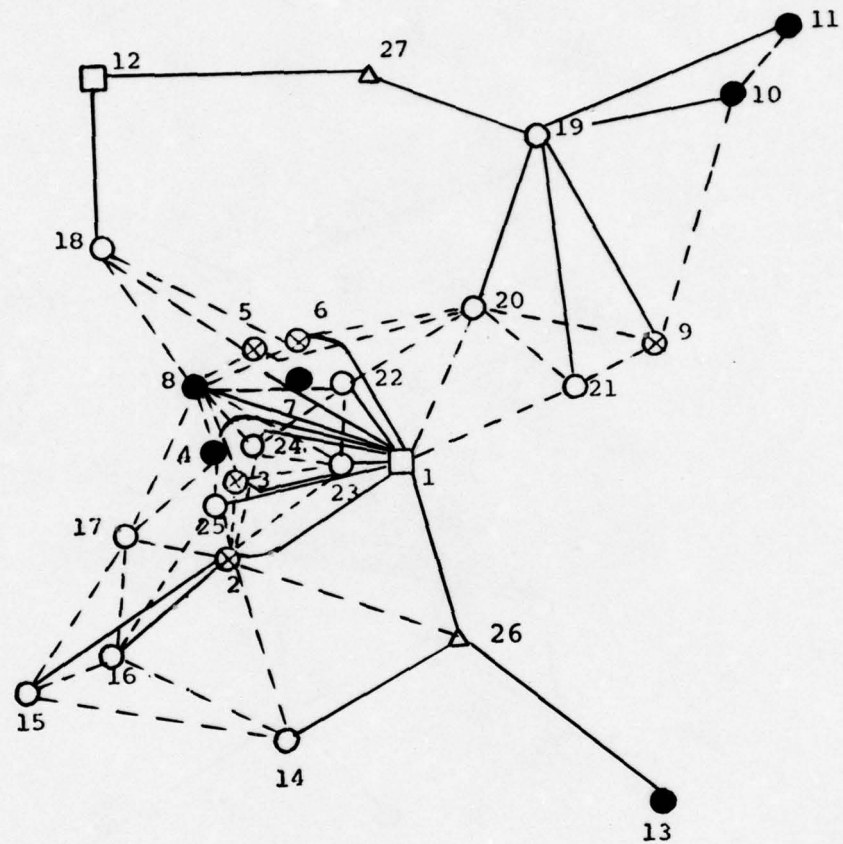

- | | | | | |
|----|---|------------------------------|-------|-------------------------|
| T | ○ | TERMINAL(S) | ————— | RADIO LINKS FOR ROUTING |
| H | ⊗ | HOST(S) | ----- | OTHER RADIO LINKS |
| HT | ● | HOST(S) AND TERMINAL(S) | | |
| BN | □ | BACKBONE NODE | | |
| PR | △ | PACKET RADIO UNIT (REPEATER) | | |

FIGURE 2.4: PRNET CONNECTIVITY AND ROUTING FOR PRU TRANSMISSION RANGE OF 25 MILES

1	2	3	4	5	6	7	8	9	10	11	12	13	14	15	16	17	18	19	20	21	22	23	24	25	
1	18	14	17	16	14	10	19	25	46	54	46	39	28	41	32	26	26	33	15	16	12	5	14	16	
2		7	10	20	21	18	16	44	64	73	48	46	18	23	14	10	32	49	32	35	19	10	10	6	
3			3	12	14	11	10	40	58	67	41	50	26	29	20	8	26	43	27	32	14	10	3	3	
4				10	13	10	6	42	59	67	38	52	27	28	20	8	22	46	27	33	14	12	3	4	
5					4	4	6	36	50	58	29	56	37	39	32	17	16	33	16	29	9	14	10	15	
6						4	10	32	46	54	31	54	38	42	34	25	19	29	16	26	5	12	12	16	
7							9	33	48	56	34	52	34	39	31	21	21	32	17	26	4	9	8	13	
8								42	56	65	31	58	35	33	26	16	16	39	26	35	14	15	8	10	
9									25	31	57	43	51	67	58	52	52	22	16	65	28	31	39	43	
10										8	58	67	74	87	78	70	59	18	30	31	39	50	56	60	
11											64	74	83	95	86	78	66	25	39	39	53	58	65	69	
12												85	65	58	55	44	16	39	41	52	37	43	37	41	
13													35	59	52	54	73	64	49	39	49	43	50	49	
14														23	17	25	50	62	45	43	34	27	27	24	
15															9	17	42	70	54	58	41	35	31	26	
16																12	38	63	47	50	31	27	22	18	
17																	27	53	38	44	21	21	19	10	
18																		41	33	44	26	30	23	26	
19																			17	24	29	35	39	44	
20																				12	14	18	26	29	
21																					21	7	11	16	
22																						8	11	16	
23																							9	12	
24																								5	
25																									

TABLE 2.4: APPROXIMATE PAIRWISE DISTANCE MATRIX IN MILES

2.5 COST COMPARISON OF CONVENTIONAL AND PACKET RADIO TECHNOLOGIES

Six PRNET designs and two designs using a conventional technology are compared in this section. The cost figure associated with a design is the monthly cost. Cost factors for the conventional designs are based on current procurement estimates for tariffed communication lines and hardware. The hardware cost factors (for both technologies) include purchase price, installation cost (20% of base price), initial support costs (67% of base price), operations and maintenance costs (47% of base cost over 10 years), and amortization over a 10 year period with 10% yearly interest.

The cost of the PRNET designs are derived as a function of the unit price cost of a PRU. Rather than having two unit cost variables, one for the PR Station and one for the PRU, the Station hardware cost is decomposed into the cost of the minicomputer PDP11/45 with an ELF operating system and 64K of core, plus the cost of a PRU (assumed together with its interface). The purchase price of the station minicomputer used in the study is \$62,200*. For example, the total monthly cost of PRNET Design 1, assuming \$10,000 purchase price per PRU is \$28,873. The monthly costs for the various hardware components of this design are shown in Table 2.5.

Two conventional minimal cost designs for the same set of computers, terminals, and backbone nodes, are used for comparison. Such designs assume the use of communications equipment (TDMX, concentrators, or terminal controllers) to merge the requirements of colocated terminals when cost-effective. Table 2.6 gives the hardware costs, line costs and total monthly costs for the conventional designs. The two designs are defined as follows:

Design C1: Each node is connected to the nearest backbone node.

* It was assumed that the cost of the PR Station is the same as the cost of a concentrator based on the same minicomputer and contains 32K of core, 64 I/O ports for low and medium speed lines, time division demultiplexing by software, and a high speed line interface to a Host computer.

Design C2: Dual homing; each node is connected to both backbone nodes.

Figure 2.5 shows the total system monthly cost for all the designs as a function of the purchase price for a PRU. It is not clear with which of the designs using conventional technology should the PRNET designs be compared. It is apparent that the PRNET designs are more reliable than Design C1, since all the nodes have radio paths to PR Stations in both backbone nodes, and routing algorithms which enable each node to communicate with both stations are available. However, PRNET designs provide less reliability than Design C2, because one PR station cannot handle all the traffic during the busy period; furthermore, the number of hops for some of the nodes when communicating with a single station is large.

Comparing PR and conventional technologies, one can see that the PR technology is more economical when the PRU purchase price is less than \$6,000 (the cost of all PRNET designs is smaller than both conventional designs). For a PRU cost of less than \$20,000, the cost of all PRNET designs are less than conventional Design C2 but some are more costly than Design C1.

Comparing the various PRNET designs shows that the total cost is not very sensitive to the different assumptions of PRU effective transmission range when PRU cost is low (say less than \$12,000). This, however, is due to the particular node distribution in the case study under consideration and the requirement that a single radio path for each node is sufficient.

To upgrade the reliability of PRNET designs to that of Design C2 it would be necessary to add several PRU's for radio connectivity, to increase backbone node capacities by using directional antennas, or to add another station in the area which does not interfere with the other stations and connected to both backbone nodes via point-to-point channels.

It is estimated that for upgrading the reliability of the PRNET designs to that of the dual homing conventional Design C2 it would be necessary to add 5 and 15 PRU's for a PRU transmission range of 25 and 12 miles, respectively. Furthermore, it is assumed that directional antennas are used in the backbone nodes to increase the capacity.

Figure 2.6 shows a comparison of Design C2 with the upgraded PRNET designs. The PRNET designs are for the two different assumptions of the number of ports per PRU and PRU transmission ranges from 12 to 25 miles. One can see that all the PRNET designs are more economical than the conventional designs for a PRU purchase price of \$15,000 or less. For a PRU purchase price of \$20,000 or less PRNET designs are more economical if the PRU transmission range is 25 miles or if a PRU has a large number of ports.

	PURCHASE PRICE [\$]	NUMBER OF UNITS	MONTHLY COST PER UNIT [\$]	TOTAL MONTHLY COST [\$]
Station Minicomputer	62,200	2	2,724	5,448
Concentrator at Node 7	62,200	1	2,724	2,724
Line Costs Node 7 - Node 1 56 Kb/s		2	972	1,944
PRU	10,000	32	585	18,720

TABLE 2.5: SAMPLE EVALUATION FOR PRNET DESIGN 1,
ASSUMING PRU PURCHASE PRICE OF \$10,000.

	TDMX MONTHLY COST [\$]	CONCENTRATOR MONTHLY COST [\$]	TERMINAL CONTROLLER MONTHLY COST [\$]	TOTAL HARDWARE MONTHLY COST [\$]	MONTHLY LINE COST [\$]	TOTAL MONTHLY SYSTEM COST [\$]
Design C1	636	3 x 2, 724	1,170	9,978	23,387	33,365
Design C2	967	3 x 2, 724	1,170	10,309	48,942	59,251

TABLE 2.6: MONTHLY COST OF CONVENTIONAL DESIGNS

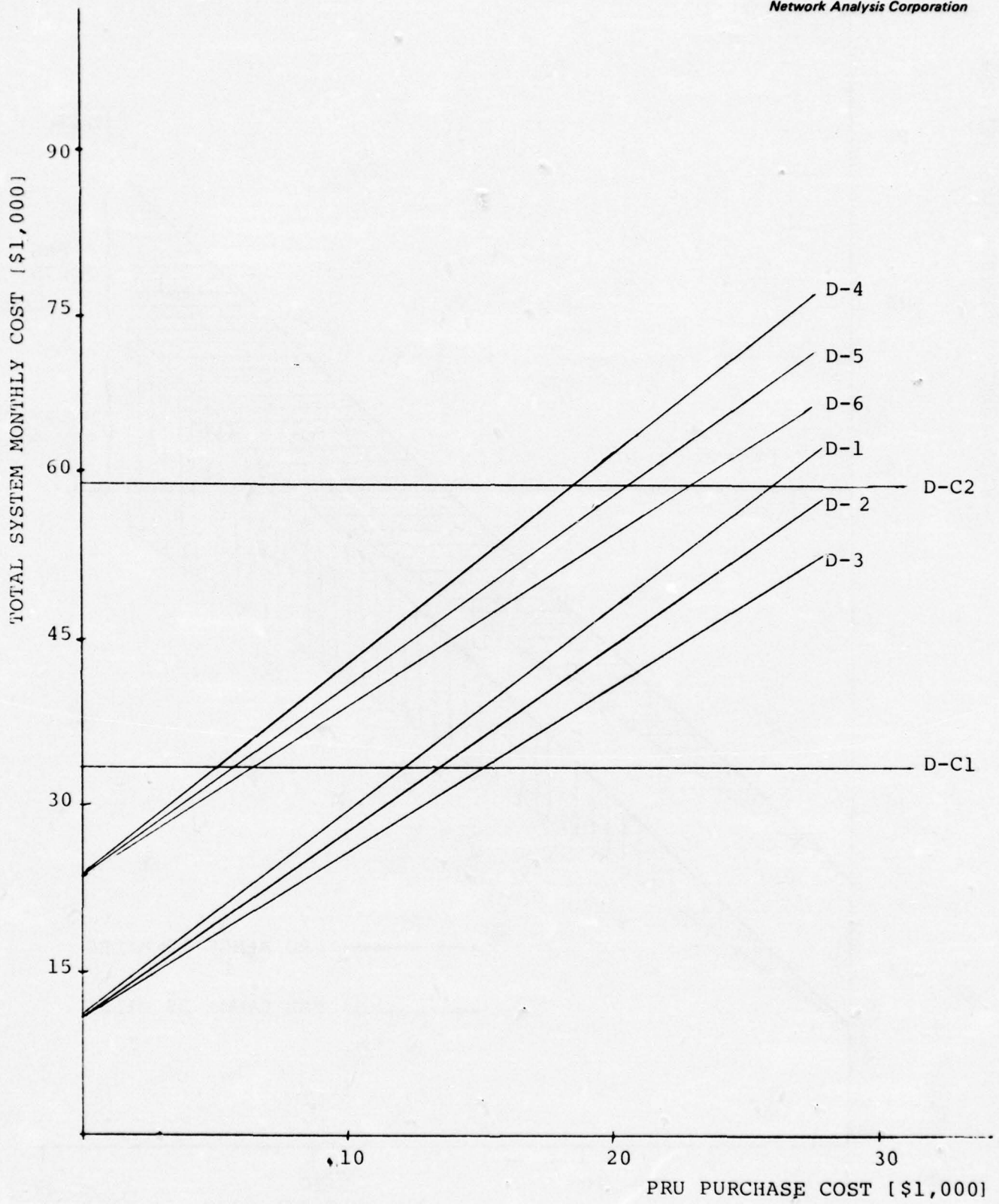

FIGURE 2.5: MONTHLY SYSTEM COST FOR ALTERNATIVE DESIGNS

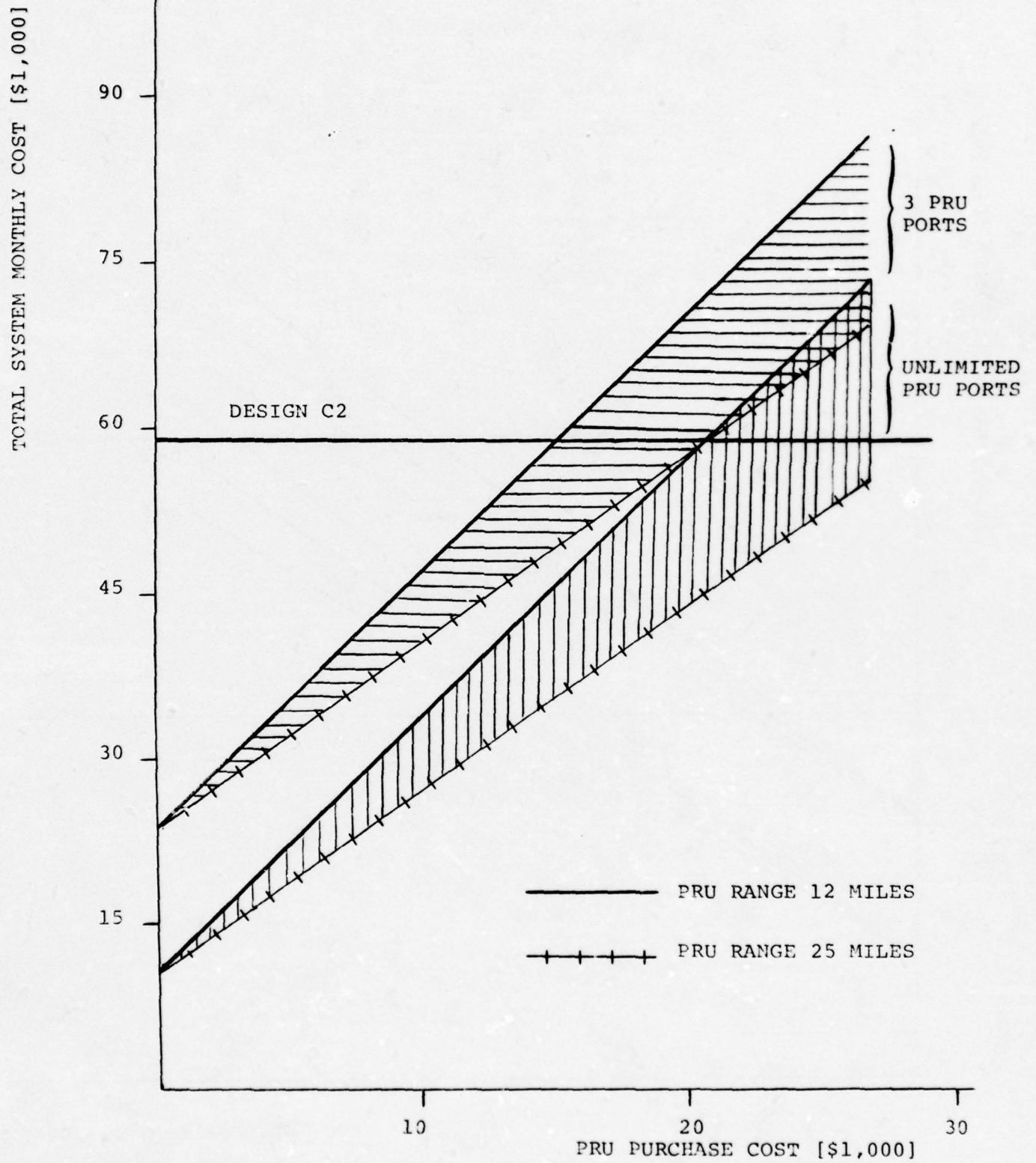

FIGURE 2.6: MONTHLY SYSTEM COST FOR ALTERNATIVE DESIGNS WITH DUAL HOMING RELIABILITY

VOLUME 4

Chapter 2

REFERENCES

REFERENCES

- [BURCHFIEL, 1975] Burchfiel, J., R. Tomlinson, and M. Beeler, "Functions and Structure of a Packet Radio Station," Proceedings of the National Computer Conference, May 1975, pp. 245-251.
- [FRANK, 1975] Frank, H., I. Gitman, and R. M. Van Slyke, "Packet Radio System - Network Considerations," Proceedings of the National Computer Conference, May 1975, pp. 217-231.
- [GARRET, 1975] Garret, J., and S. Fralick, "Technological Considerations for Packet Radio Networks," Proceedings of the National Computer Conference, May 1975, pp. 233-243.
- [GITMAN, 1975] Gitman, I., "On the Capacity of Slotted ALOHA Networks and Some Design Problems," IEEE Transactions on Communications, March 1975, Vol. COM-23, No. 3, pp. 305-317.
- [GITMAN, 1976] Gitman, I., R. M. Van Slyke, and H. Frank, "Routing in Packet Switching Broadcast Radio Networks," IEEE Trans. on Communications, August 1976.
- [KAHN, 1975] Kahn, R.E., "The Organization of Computer Resources Into a Packet Radio Network," Proceedings of the National Computer Conference, May 1975, pp. 233-243.

REFERENCES (cont'd)

- [KLEINROCK, 1975] Kleinrock, L., and F. Tobagi, "Random Access Techniques for Data Transmission Over Packet Switched Radio Channels," Proceedings of the National Computer Conference, May 1975, pp. 187-201.
- [NAC, 1974] Network Analysis Corporation, "Area Coverage by Line-of-Sight Radio," in The Practical Impact of Recent Computer Advances on the Analysis and Design of Large Scale Networks, Third Semi-annual Technical Report, June 1974, available from Defense Communication Center, Arlington, Va.
- [NAC, 1976A] Network Analysis Corporation, "Performance Evaluation of Packet Radio Networks," Recent Advances in Ground Packet Radio Systems, Sixth Semiannual Technical Report, Vol. 2, February 1976, available from Defense Communication Center, Arlington, Va.
- [NAC, 1976B] Network Analysis Corporation, "Reliability Considerations in Packet Radio Networks," Recent Advances in Ground Packet Radio Systems, Sixth Semiannual Technical Report, Vol. 2, February 1976, available from Defense Communication Center, Arlington, Va.
- [NAC, 1976C] Network Analysis Corporation, "Stability Considerations in Packet Radio Networks," Recent Advances in Ground Packet Radio Systems, Sixth Semiannual Technical Report, Vol. 2, February 1976, available from Defense Communication Center, Arlington, Va.

VOLUME 4

Chapter 3

AN URBAN ALTERNATIVE

3. AN URBAN ALTERNATIVE

3.1 INTRODUCTION

In urban areas two difficulties impede the reception of radio signals in buildings:

1. The attenuation of signals in passing through building walls; and
2. The reception of multipath signals due to reflections off buildings.

In a study of the in-building reception problem, C. H. Vandament of Collins Radio concludes,

"...signal strength environment on a city street will probably need to be 25 to 30 db higher than that previously considered if direct radiation into buildings is to be considered (i.e., no building distribution system employing amplification). This is quite unattractive since this implies either excessive transmit power and/or quite close repeater spacing." [VANDAMENT, 1973]

Both of these problems can be avoided while still retaining the main idea of using ALOHA random access multiplexing. Instead of operating in an over-the-air broadcast transmission mode, data can be sent over the existing wideband coaxial cable facilities of master antenna (MATV) and cable television (CATV) systems. Recent FCC rulings require that all new CATV systems have two-way capability. Penetrations of 40-60% of U.S. homes is projected by the end of the decade [SLOAN, 1971]. Moreover, most of the major new office buildings will have wide band communication channels built in. For example, in the New York World Trade Center, there is a system of

switched wideband communication channels. The user can select 60KHz audio channels or 15 MHz video channels and has an individual wideband cable connection to the central switch [FRIEDLANDER, 1972]. By 1980, "the wired city" will be close to reality.

Vandament, after considering radiation, telephone wires, power cables, and other special wiring schemes for the in-building problem, comes to a similar conclusion regarding the merits of coaxial cable transmission:

"...Every building will require some analysis to determine which technique is required to deliver a useable signal to a terminal inside. If the building has windows and is relatively close to a system repeater, no special techniques will be required. At greater distances, a simple repeater with directional antennas focused on specific buildings will deliver the signals to interior users by radiation. Buildings which are effectively shielded must have a simple, dedicated repeater to receive a signal and pipe it into the building over conductors of one type or another... High grade coaxial cables solve that problem nicely, but this answer would probably be prohibitively expensive for the packet radio scenario of general distribution throughout every important building in the U.S. ...Where such cables exist, they do offer an attractive solution to the in-building distribution problem." [VANDAMENT, 1973]

In the next chapter we will describe experiments to show the technical merits of MATV systems for solution of the in-building problem and CATV systems for local distribution in high density suburban and urban areas. We first describe the properties of typical modem MATV and CATV systems.

In the remainder of this chapter we describe the specifications and operation of typical modern MATV and CATV systems. We briefly review the data options available for use on cable video systems and summarize the merits of a random access packet system for the video environment as determined on a theoretical basis. For example on a typical CATV system, the Surburban Boston system, with data being transmitted in a 6MHz video band at a one Megabit per second pulse rate, about 27,000 data sets can be supported on a trunk. In other words, with a data set for every TV set, one-third of all terminals can be active at any time with a negligible bit error rate (10^{-22}) and no interference with video performance. The subject of the next chapter is the description of experimental verification of this theoretical capability.

3.2 A TYPICAL MATV SYSTEM

A master antenna television system as shown in Figure 3.1 serves a concentration of television sets such as in an apartment building, hotel, or motel. The main purpose of the MATV system, as shown in Figures 3.2, 3.3, 3.4, is to provide a usable signal to a large number of television sets fed by a local distribution network.

A number of television sets connected to the same antenna system without a signal amplifier would not provide any of the sets with a strong enough signal to produce good pictures. An all-channel master antenna amplifier is connected to one antenna (sometimes more) which provides across-the-band amplification of all television signals in the VHF band and the F. M. broadcast band.

Some MATV systems employ more than one amplifier. A separate single-channel amplifier may be used as shown in Figure 3.5, to provide greater amplification of a single channel. Generally, a separate antenna is used with a single-channel amplifier.

For reception of UHF television stations, a UHF-to-VHF translator is required.

For MATV systems with more than 100 outlets, further amplification may be required, and in a large office building cascades of two or three amplifiers might be expected. Nevertheless, compared to CATV systems - to be described in the next section - modern MATV systems are relatively uncomplicated media for data transmission. Signal to noise ratios of better than 43 dB are reasonable; there are few environmental problems, since the system is indoors; there is minimal temperature variation; and amplifier cascades are low since the wideband capabilities of 0.5 inch coaxial cable are used. In a CATV system, the signal at the building is received from a cable distribution system rather than from antennas. However, the in-building part of the system is essentially unchanged from that used for an MATV system.

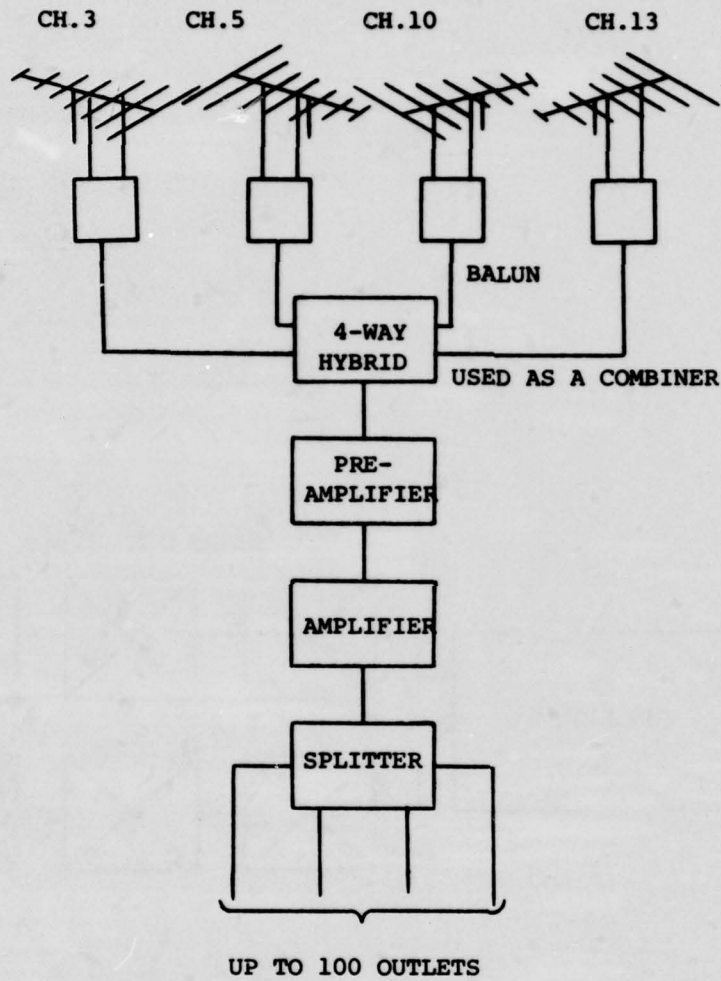

FIGURE 3.1: TYPICAL HOTEL OR APARTMENT BUILDING MATV SYSTEM

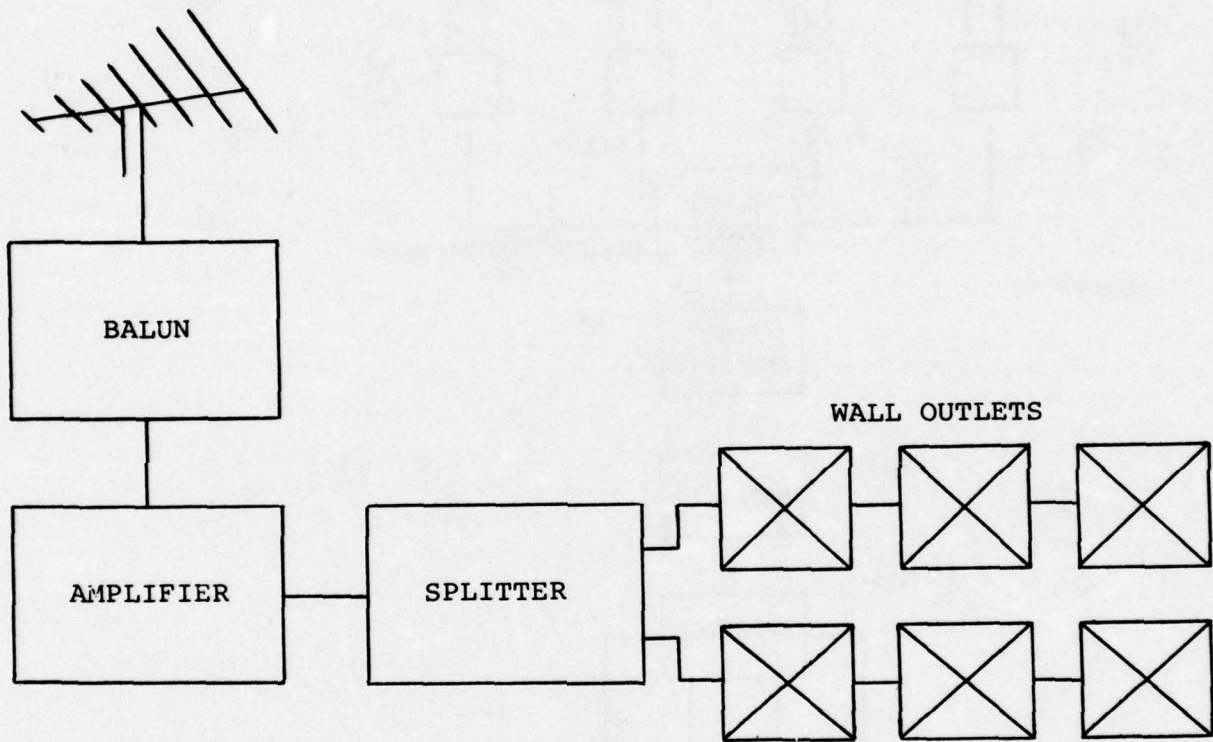

FIGURE 3.2: TYPICAL MOTEL MATV SYSTEM

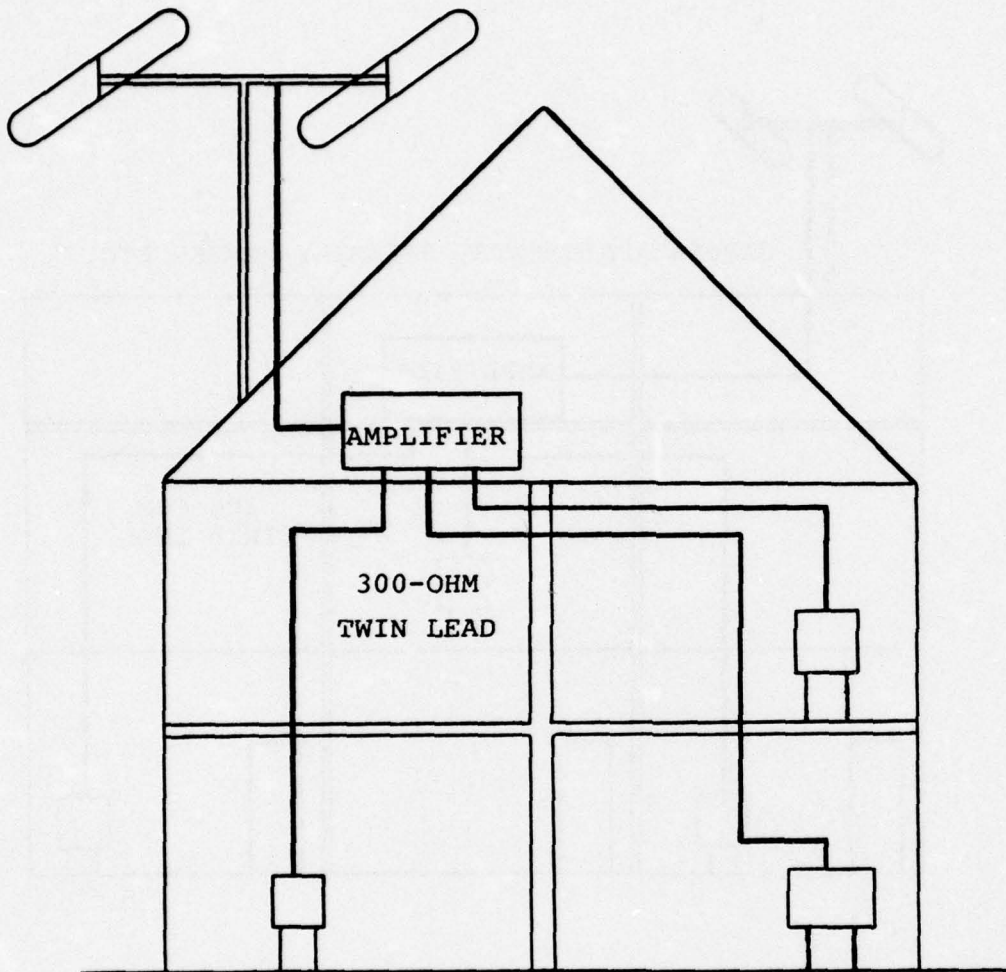

FIGURE 3.3: TYPICAL HOME MATV SYSTEM

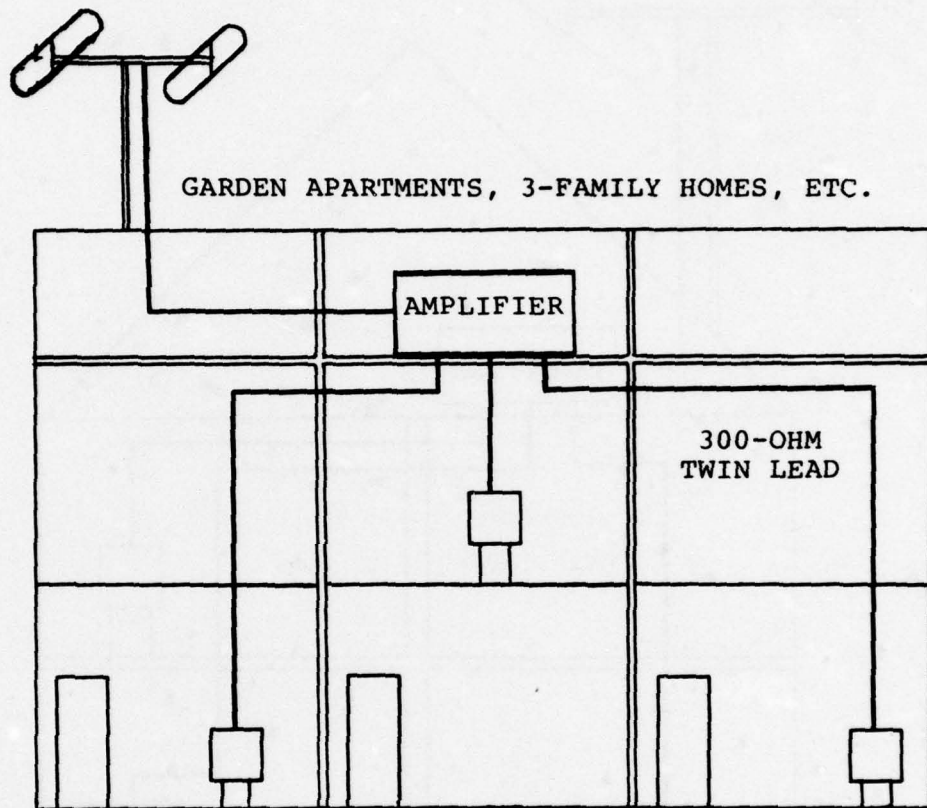

FIGURE 3.4: MATV SYSTEM FOR MULTIPLE DWELLING

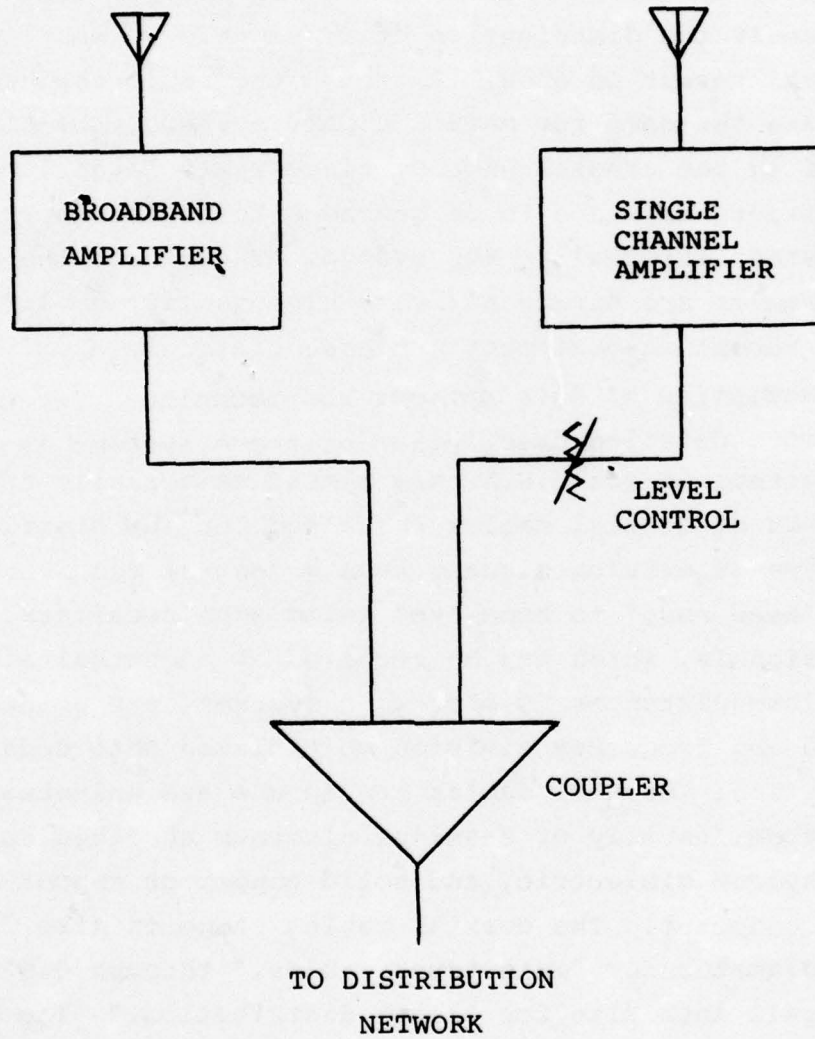

FIGURE 3.5: USE OF SINGLE CHANNEL AND BROADBAND AMPLIFIERS FOR RECEIVING DISTANT STATIONS

3.3 A TYPICAL CATV SYSTEM

CATV systems are a historical outgrowth of MATV and community antenna television systems. CATV systems perform roughly the same function for an entire town that an MATV system performs for a building, namely the distribution of TV signals to many terminals from a central reception area. Although the basic engineering strategies are the same for MATV and CATV systems, the CATV system is different in one crucial aspect; since it is larger, as many as thirty amplifiers may have to be cascaded to deliver a TV signal to the most distant terminal in the system. Therefore, the system design requirements are stringent; very high quality amplifiers and off the air reception equipment are essential. In order to motivate our description of data options and techniques for CATV systems, a somewhat more detailed description of these systems is in order.

CATV systems in the U.S.A. are almost universally tree structured networks of coaxial cables installed for the distribution of broadcast type television signals from a central receiving station, called the "head end," to home type television receivers. Different television signals, which may be received at a central site or relayed over long distances by microwave systems, are processed at the head end and frequency division multiplexed onto coaxial cable for distribution. Coaxial cables now in use are universally 75 ohm impedance types, usually of seamless aluminum sheathed construction, foam polyethylene dielectric, and solid copper or copper clad aluminum center conductor. The coaxial cables range in size from 0.75 inch outer diameter for "main trunk cables," through 0.5 inch size down to a 0.412 inch size for "local distribution." The service drop lines to the houses are usually flexible cables of about 0.25 inch diameter. The useful frequency range includes the VHF television band, 54-216 MHz, and broadband transistorized amplifiers are installed with equalizers to compensate for cable losses. Practical systems are aligned to be unity gain networks with amplifiers

spaced about 20 dB at the highest transmitted frequency.

Cable losses range from about 1 dB/100' at 220 MHz for the 0.75 inch size cable to about 5 dB/100' for the flexible service drop cables. Power division at multiple cable junctions and taps into subscribers' homes are accomplished through hybrid and directional couplers. All system components are carefully matched to 75 ohms to minimize internal signal reflections within the system.

System amplifiers are subject to rigorous linearity specifications. Amplifier overloads manifest themselves as cross-modulations between channels and as undesired second and third order intermodulation and harmonic products. Amplifier operating levels are bounded on the lower side by system signal to noise ratio objectives which are about 40 dB over a 4 MHz band for acceptable performance as a television distribution system. A typical system will have amplifier inputs at about +10 dBmV and outputs at about +30 dBmV. System operating levels are controlled by automatic gain control circuits driven by pilot carriers and thermal compensation devices.

More recent cable systems have been built using a "hub" principal in which tree structured networks originate from a number of "hubs" throughout the community serviced (see Figure 3.6). The "hubs" may contain equipment for more elaborate control of signal levels and it may be possible to perform some special switching functions such as the interconnection of sub-trunks for special purposes.

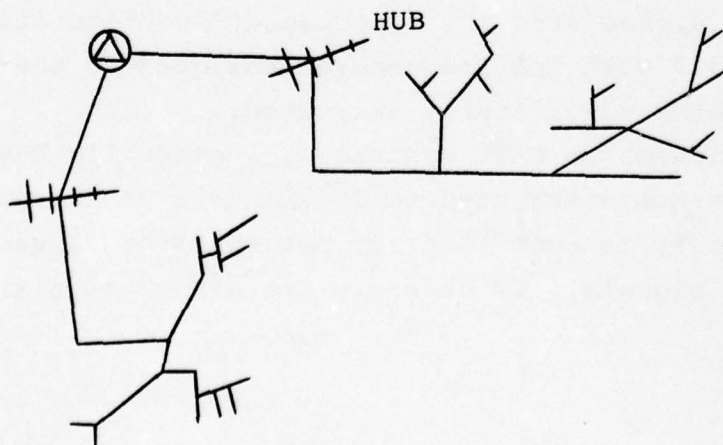

FIGURE 3.6: HUB SYSTEM

FCC regulations now require that new CATV systems must have two-way capability. Practically speaking, this does not mean that all new systems are two-way systems, but rather that amplifier units are installed with forward amplifier modules in place and with distances between amplifiers constrained so that at some future date reverse amplifier modules can be installed for two-way operation. However, a number of actual fully two-way systems are presently being built and the number is increasing rapidly. Most present two-way systems use the configuration in Figure 3.7. Filters at each end of the station separate low (L) and high (H) frequencies and direct them to amplifiers usually referred to as "downstream" from the head end and "upstream" toward the head end.

A number of possible "two-way" configurations are shown in Figures 3.7, 3.8, and 3.9 [JERROLD, 1971]. The final choice between single cable/two-way, multi-cable/two-way, and multi-cable without two-way filters will probably be made on the basis of marketing opportunities for special services.

There are no Government regulations as to minimum specifications for a system. Hence, we will base our discussion on the characteristics of a representative two-way system, the Suburban Boston complex. This system has been built in about 10 stages, and is one of the largest systems in existence in the U.S. The Boston Suburban system uses the "feedback" configuration shown in Figure 3.9 with the frequencies assigned to the upstream and downstream paths specifically indicated.

Data transmission on CATV systems will generally have to be fitted into space not being used to TV channels or for pilot frequencies. Hence, it is best to first describe the frequency allocation for video signals. TV channels are allocated six MegaHertz

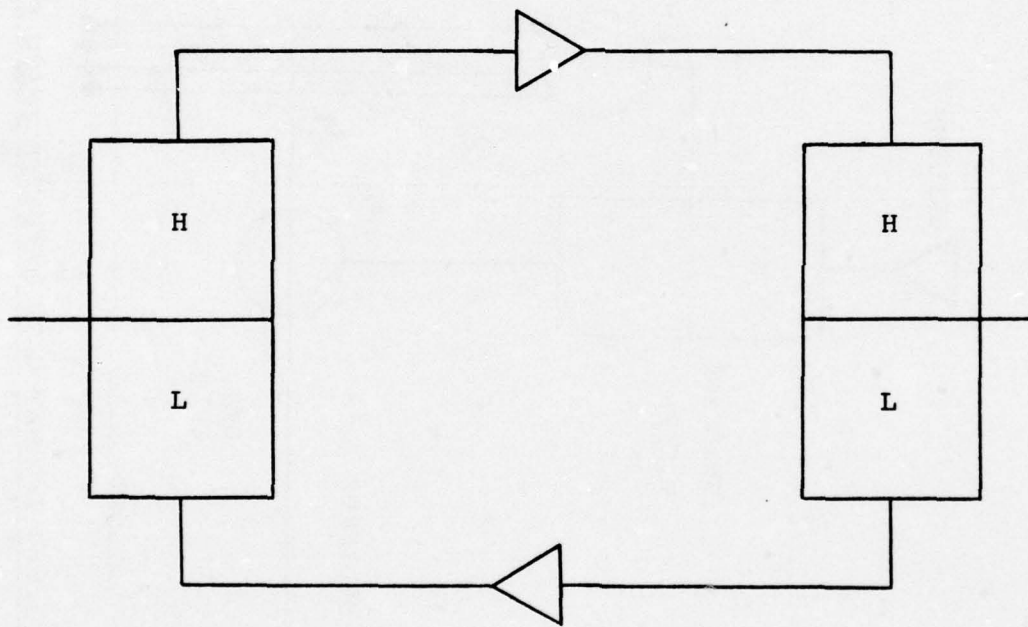

FIGURE 3.7: TWO-WAY AMPLIFIER

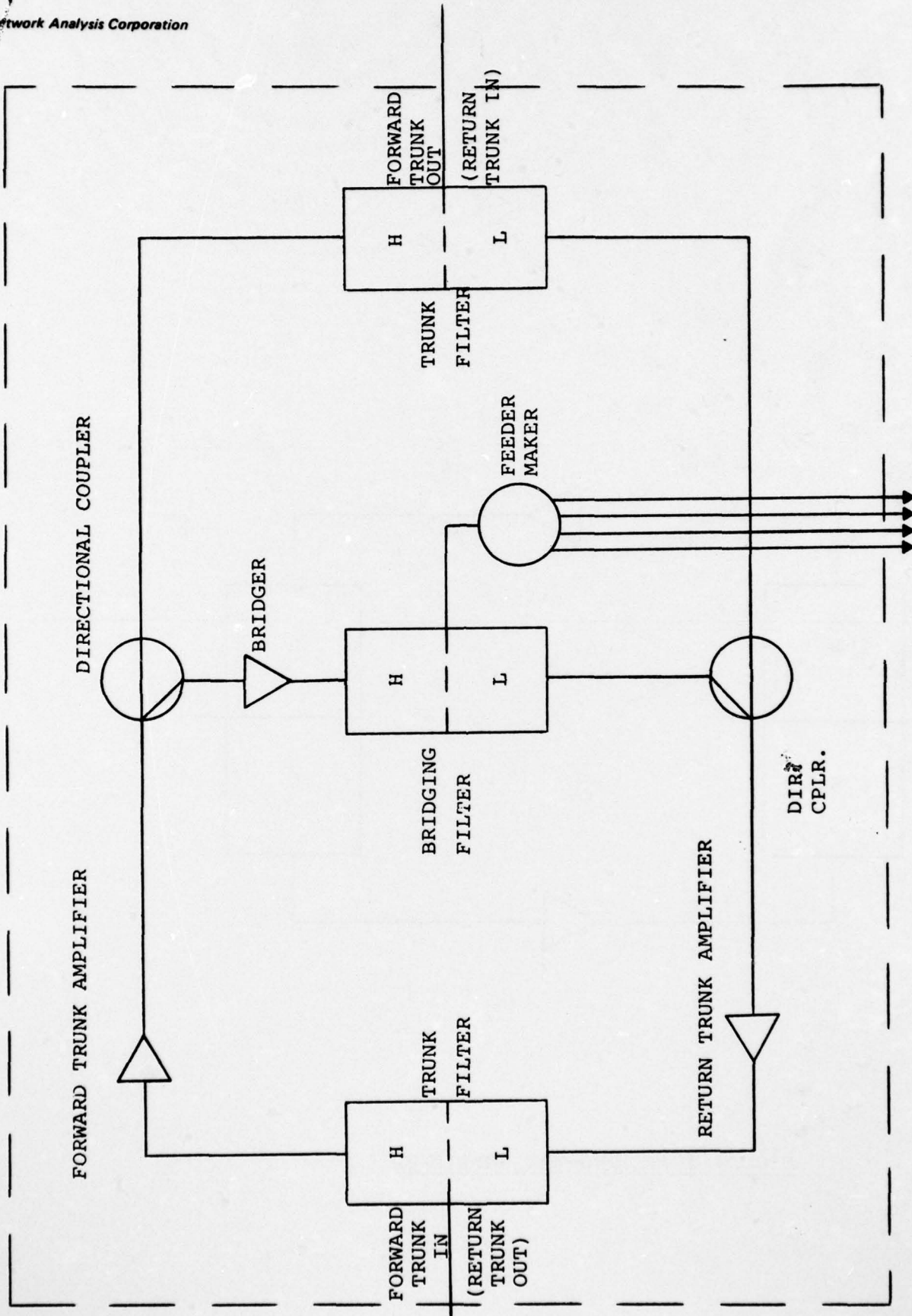

FIGURE 3.8: TWO-WAY CATV REPEATER (WITH FEEDERS)

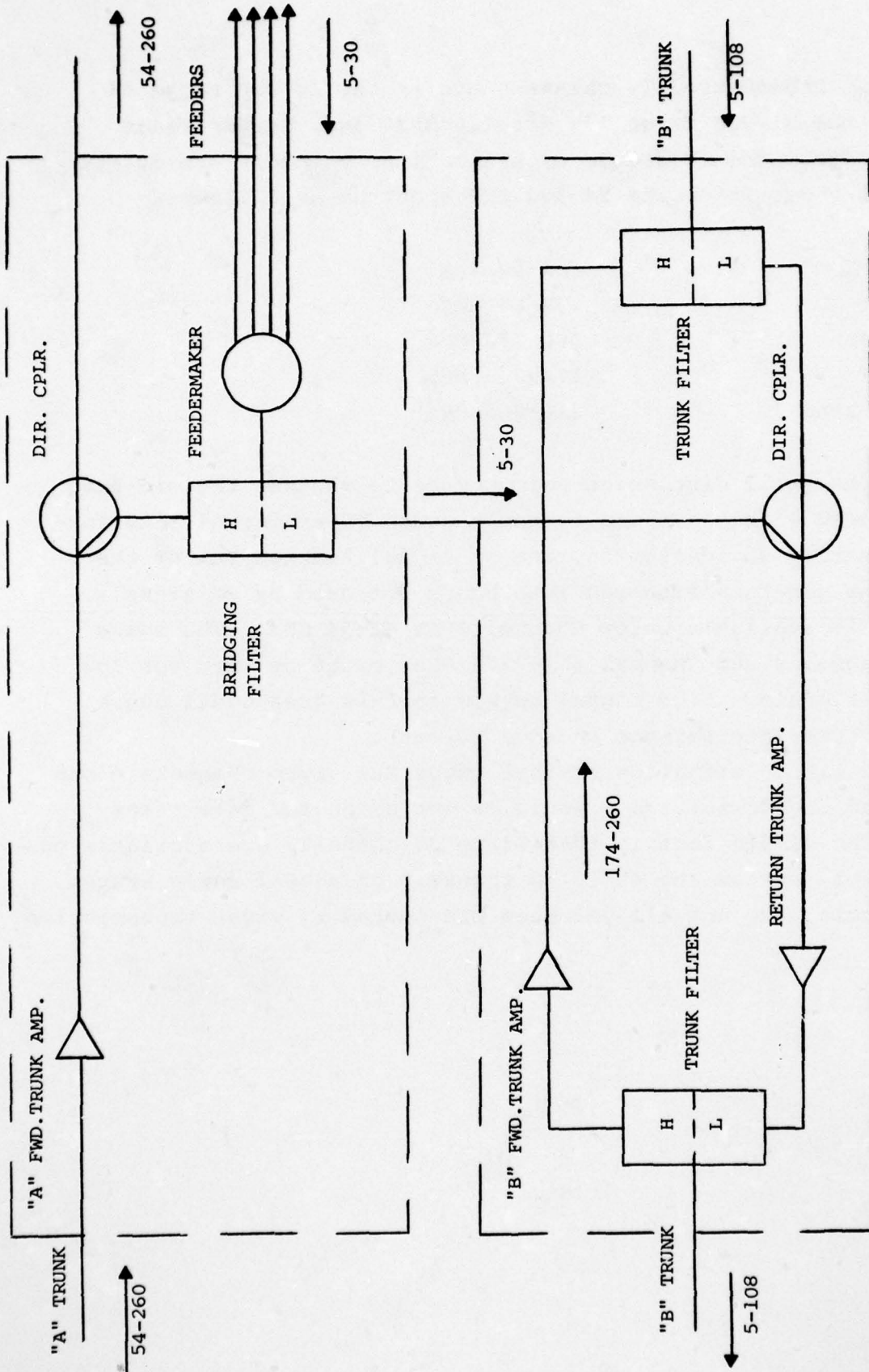

FIGURE 3.9 DUAL TRUNK/SINGLE FEEDER STATION
(SUBURBAN BOSTON CONFIGURATION)

bandwidths. Broadcasted TV channels are in the Lo-VHF range 54 MHz-88MHz, the Hi-VHF range 174 MHz-216 MHz, and the UHF range 470 MHz-890MHz. The TV frequency allocations on cable are different. They partition the 54-300 MHz spectrum as follows:

Sub-VHF	5-54 MHz
Lo-VHF	54-88 MHz
Mid-band	88-174 MHz
Hi-VHF	174-216 MHz
Super-band	216-300 MHz

There is still discussion going on as to whether the mid-band should be used within a cable system because of danger of interference to aircraft navigation in case of signal leakage out of the cable. Data might be squeezed into bands not used by TV signals. Some space is available below Channel 2 at 48-54 MHz. The space between Channel 4 and Channel 5 (72-76 MHz) might be used for low level data signals. High signal levels in this area could cause harmful picture interference on some TV sets.

A more likely situation is that two 6 MHz video channels - one upstream and one downstream - would be set aside for data transmission. The simple fact is that 21 to 30 channels are available on a single cable system and 42 to 60 channels on a dual cable system. These channels have not all yet been pre-empted by video transmission.

3.4 DATA OPTIONS ON MATV AND CATV SYSTEMS

Most two-way systems are being developed with an upstream channel designed to permit input from virtually any location in the network. The result is a large number of noise sources being fed upstream toward a common source. Individual cable television amplifiers usually have a noise figure of about 10 dB for a 6 MHz channel. Cascading amplifiers can increase effective system noise figure by 30 dB or more. Nevertheless, we shall see that system specifications on signal-to-noise ratio for CATV systems are stringent enough so that packets can be sent with existing analog repeaters, and no digital repeaters, such that bit rate error probabilities are negligible.

For example, in the Boston suburbs the worst signal-to-thermal noise ratio is limited to 43 dB and the worst cross-modulation to signal ratio is limited to -47 dB. System operators may want to limit data channel carriers to a level of 10 to 20 dB below TV operating levels in order to minimize additional loading due to the data channel carriers [SWITZER, 1972]. The cable operator, at least for the time being, is making his living by providing a maximum number of downstream television channels and will accept data channels only on a non-interfering basis.

Accepting these restrictions, in the worst case, we would be limited to 23 dB signal to thermal noise ratio and -27 dB cross-modulation to signal ratio. Let us consider both of these sets of restrictions to determine the resulting CATV system performance for random access packet transmission.

We can calculate the error rates [FRISCH, 1975] for a FSK system with incoherent detection to determine a lower bound for system performance. It is well known that for effective signal-to-noise ratios above 20 dB there is a threshold effect for error probabilities. This is born out by the fact that even for the specifications degraded by 20 dB the bit error rate is low enough for the most stringent practical data requirements, namely about 10^{-22} .

Furthermore, at a rate of 10^6 pulses/second the FSK signal will occupy the 6 MHz bandwidth [SWITZER, 1972] with negligible inter-modulation into TV channels [SCHWARTZ, 1966].

In Figure 3.10 we plot the maximum number of active terminals for a number of systems [FRISCH, 1975]. The curves labeled A, B, C, and D correspond to slotted systems. The lines labeled A', B', C', and D', are for the corresponding unslotted systems.

We can now examine Figure 3.10 to determine system performance under some typical data transmission requirements. For a data rate of 40 bits/second per terminals, a single trunk can handle 9,000 terminals with a slotted ALOHA system (1 Megabit/sec) with an error rate of 10^{-22} at a signal to noise ratio degraded by 20 dB. The average number of TV sets per trunk in Suburban Boston is approximately 27,000. Hence, the simplest modulation scheme will handle one-third of all terminals in Boston as active terminals. At 100 Kbits/second, the system will handle 900 active terminals.

In order to use the random access packet mode on an MATV or CATV system the simplest scheme shown in Figure 3.11 is, therefore, adequate. All terminals have an interface which addresses and packetizes messages, and which sends packets as soon as they are ready. The interface triggers a modem which modulates a carrier in the video band. All packets are received by a modem and interface at the head end and then passed to a minicomputer controller which sends packet back along all trunks or the appropriately addressed trunk. Those interfaces to which the packets are addressed receive them and all others ignore them. Incorrectly received packets, such as those which overlap other packets, are simply retransmitted.

The results of these theoretical studies and others described in NAC's Fourth ARPA Semiannual Technical Report indicate that commercial MATV and CATV systems are extremely promising vehicles for random access packet data transmission. Nevertheless, a number of properties of MATV and CATV systems are difficult to model

	(N_c/S)	(S/N_r)	m
A	-47dB	43dB	2
B	-47dB	43dB	4
C	-47dB	43dB	8
D	-27dB	23dB	2

N_c = CROSS MODULATING SIGNAL POWER

N_r = NOISE POWER

S = SIGNAL LEVEL

m = NUMBER OF FREQUENCY LEVELS

ALOHA SYSTEM
 1×10^6 PULSES/SEC.

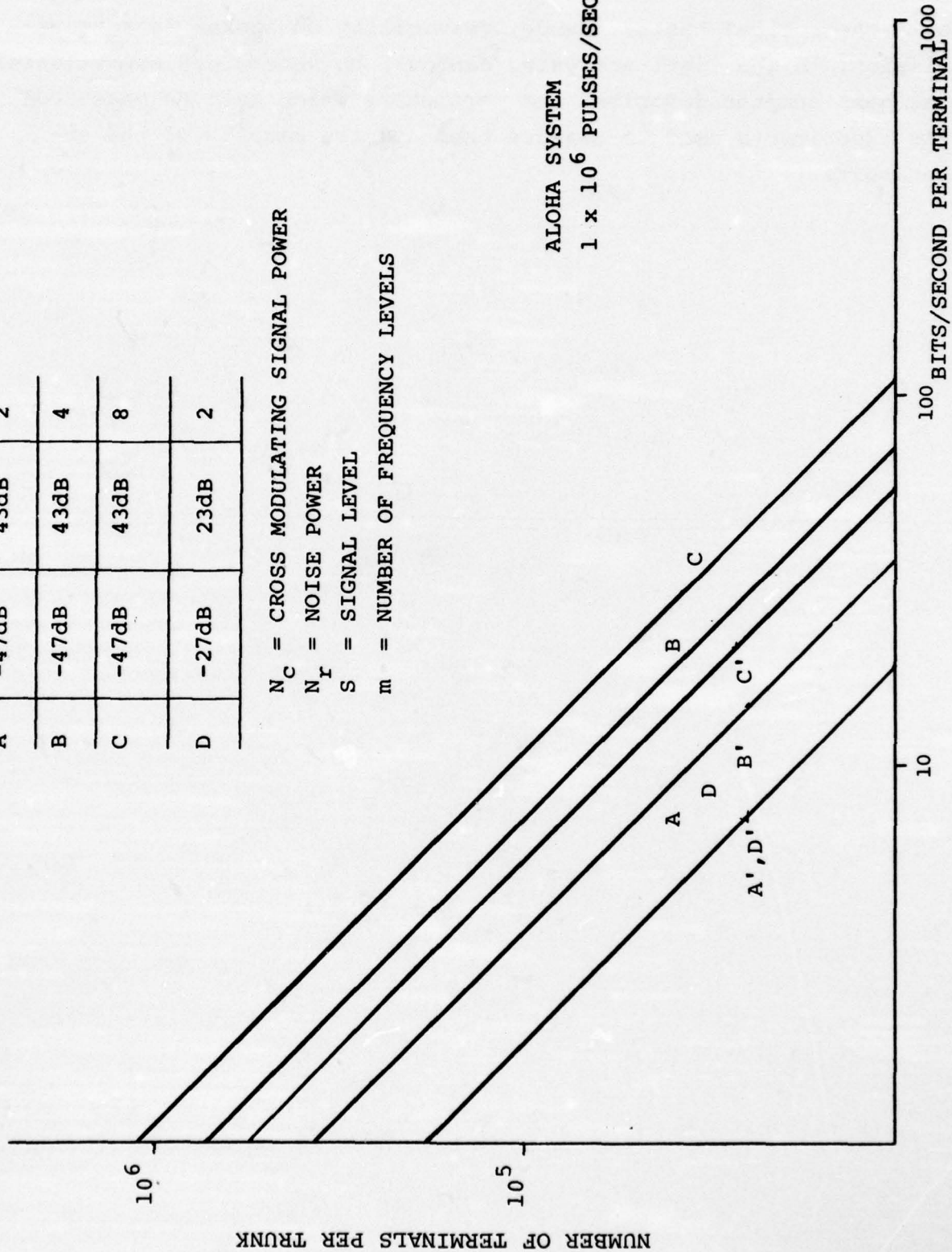

FIGURE 3.10: NUMBER OF TERMINALS PER TRUNK VS. BITS/SEC. PER TERMINAL

on a theoretical basis. Hence, feasibility of packet data transmission, in the final analysis, can only be determined experimentally. The next chapter describes the parameters which must be measured, the experiments used to measure them and the results of the experiments.

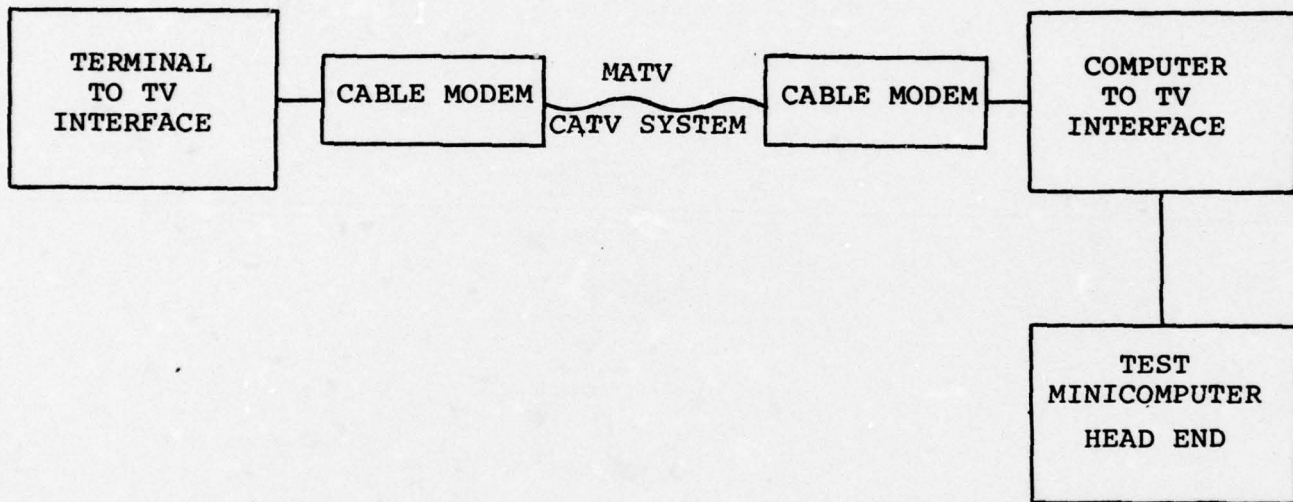

FIGURE 3.11: SYSTEM DIAGRAM

VOLUME 4

Chapter 3

REFERENCES

REFERENCES

- [FRIEDLANDER, 1972] Friedlander, G. D., "Super Communications for World Traders," IEEE Spectrum, March 1972, pp. 74-83.
- [FRISCH, 1975] Frisch, I. T., "Technical Problems in Nationwide Networking and Interconnection," IEEE Transactions on Communications, Vol. COM - 23, No. 1, January 1975, pp. 78-88.
- [JERROLD, 1971] Jerrold Electronics Corporation, "Publicity Release on Two-Way CATV Systems", National Cable Television Convention, 1971.
- [SCHWARTZ, 1966] Schwartz, M., W. R. Bennett and S. Stein, Communication Systems and Techniques, McGraw-Hill, 1966.
- [SLOAN, 1971] Sloan Commission, "On the Cable: The Television of Abundance," Report on Cable Communications, McGraw-Hill, 1971.
- [SWITZER, 1972] Switzer, I., "The Cable System as a Computer Network," Proceedings of Symposium Computer-Communications Networks and Teletraffic, Polytechnic Institute of Brooklyn, New York, April 1972, pp. 339-346.
- [VANDAMENT, 1973] Vandament, C. H., Private Correspondence.

VOLUME 4

Chapter 4

**EXPERIMENTS ON PACKET DATA TRANSMISSION OVER CABLE
VIDEO SYSTEMS**

4. EXPERIMENTS ON PACKET DATA TRANSMISSION OVER CABLE
VIDEO SYSTEMS

4.1 INTRODUCTION

The theoretical calculations in the last chapter have shown that MATV and CATV Systems should provide near ideal media for the transmission of packetized digital data. However, a number of idealizations were necessarily made in the model. The effect of these simplifications can only be judged by experiment. The purpose of the experiments described in this chapter are to verify our theoretical calculations for MATV Systems and by extrapolation to CATV Systems.

The simplifications made in the theoretical calculations were the following:

1. Interfering signals from adjacent channels were assumed Gaussian.
2. Only simple nonlinearities were assumed for amplifier characteristics.
3. Group delay variation was assumed small over an entire video band.
4. Filters, cable and passive connectors were assumed ideal.
5. Ideal modem and interface performance was assumed.
6. It was assumed that MATV equipment met all manufacturers' specifications.

The results of the experiments are that the assumptions were reasonable and that commercial MATV systems will quite readily support random access packet data transmission. We attempted to run tests under ranges of parameters corresponding to CATV systems as well. For example signal levels at the antenna and modem were reduced to reduce signal to noise ratio. Similarly amplifier performance was found to be good enough for data so that if the performance of a long cascade of amplifiers were adequate for video transmission it would be satisfactory for data transmission. Nevertheless, certain factors, such as system reliability, could only be verified for a CATV system by further testing on an actual CATV system. These additional factors are discussed in the conclusion.

The test system itself is installed at the Network Analysis Corporation. The advantages of this mode of operation are the following:

1. Since the system is at NAC, there were no initial problems of equipment transportation.
2. The system is completely local and hence, we had no initial restrictions on TV interference or picture quality.
3. There were no initial restrictions on carrier frequencies or bandwidth.
4. The initial system could be varied in structure and performance to approximate the degradation in any CATV system.
5. A final advantage of performing the tests on a high quality, well-built MATV system is that it completely proved out the viability of using MATV systems to solve the in-building distribution problem.

The MATV system meets the following general specifications:

- a. The system feeds all 38 rooms in the major building at NAC.
- b. The system receives all available off-the-air channels.
- c. The system covers the full VHF range.
- d. The head end amplifier is driven at full output capability to test significant noise and cross modulation figures.
- e. The system is two-way so that at any tap, a signal modulated by digital data can be inserted and received at any other tap.
- f. The system contains at least one leg of several hundred feet to obtain signal degradation.
- g. The system contains converters so that experiments at varied frequencies can be performed.

4.1.1 MATV System Operation

The layout of the system is shown in Figure 4.1a with most of the trunk cable running around the outside of the building between the first and second floor and about 50' feet of drop cable for each tap port, running into individual offices. A functional block diagram of the final system is given in Figure 4.1b, with a legend in Figure 4.1c. Significant points in Figure 4.1b are labelled with letters for ease of reference. Levels are in dBmV, relative to 0 dBmV as the power level due to 1 mV across 75 Ω .

The basic system operation is as follows. A high quality, log periodic antenna carries signals to point M, which are fed to the amplifier and through the system at points N and O. The amplifier contains forward and reverse modules. The forward and return signals are separated by high pass low pass filters. At Point M, there is a directional coupler so that test signals can be obtained directly from the antenna. After Point O, a splitter, with the leg Q going to test points, can be monitored by a field strength meter or a TV monitor. In the reverse direction, a TV camera can feed signals into a modulator at frequency T10* which then proceeds in the reverse direction to the amplifier from O to N and can then be fed around the loop GJL via the T10-8 converter. The signal can then be fed downstream again to any point, on Channel 8. Similarly, a digital signal can be fed through a teletype into an interface at a point such as C in band T8**. It is then fed again through the reverse amplifier from O to N, this time can pass around the loop NHIKL via the T8-6 converter and, therefore, can then be sent through the forward amplifier to any other point, on Channel 6. A switch indicated at point B allows us to bypass the MATV distribution system

* T10 covers the frequency range 23.75 to 29.75 MHz

** T8 covers the frequency range 11.75 to 17.75 MHz

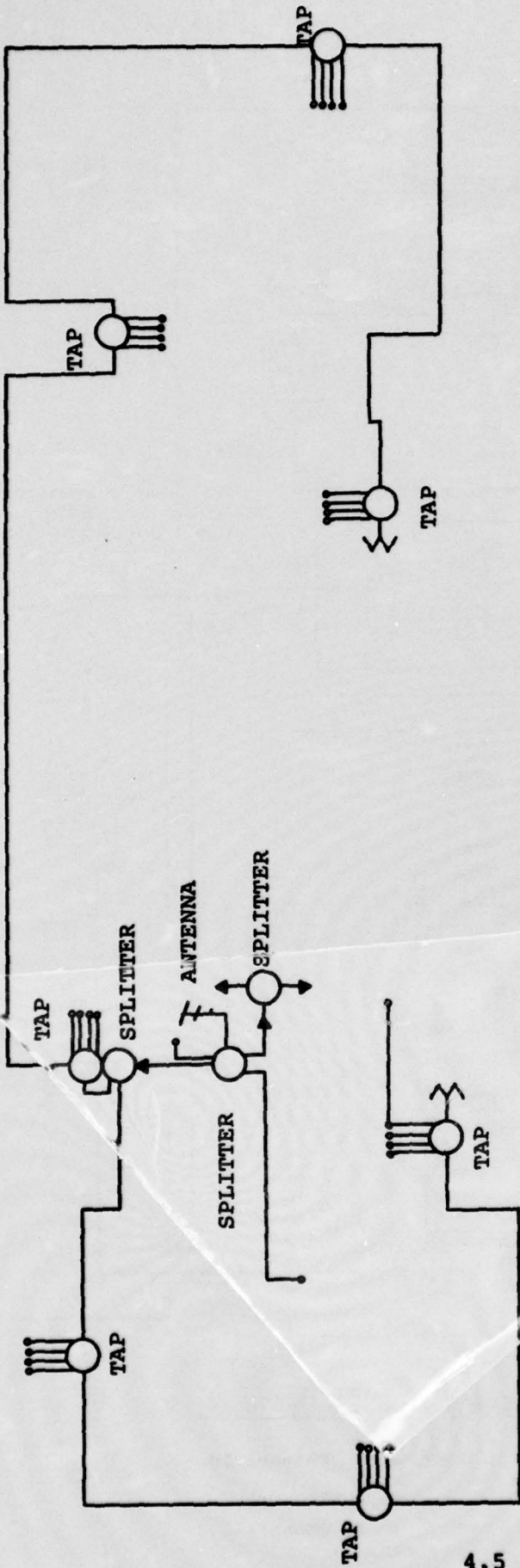

FIGURE 4.1a: SYSTEM LAYOUT 1" = 15'

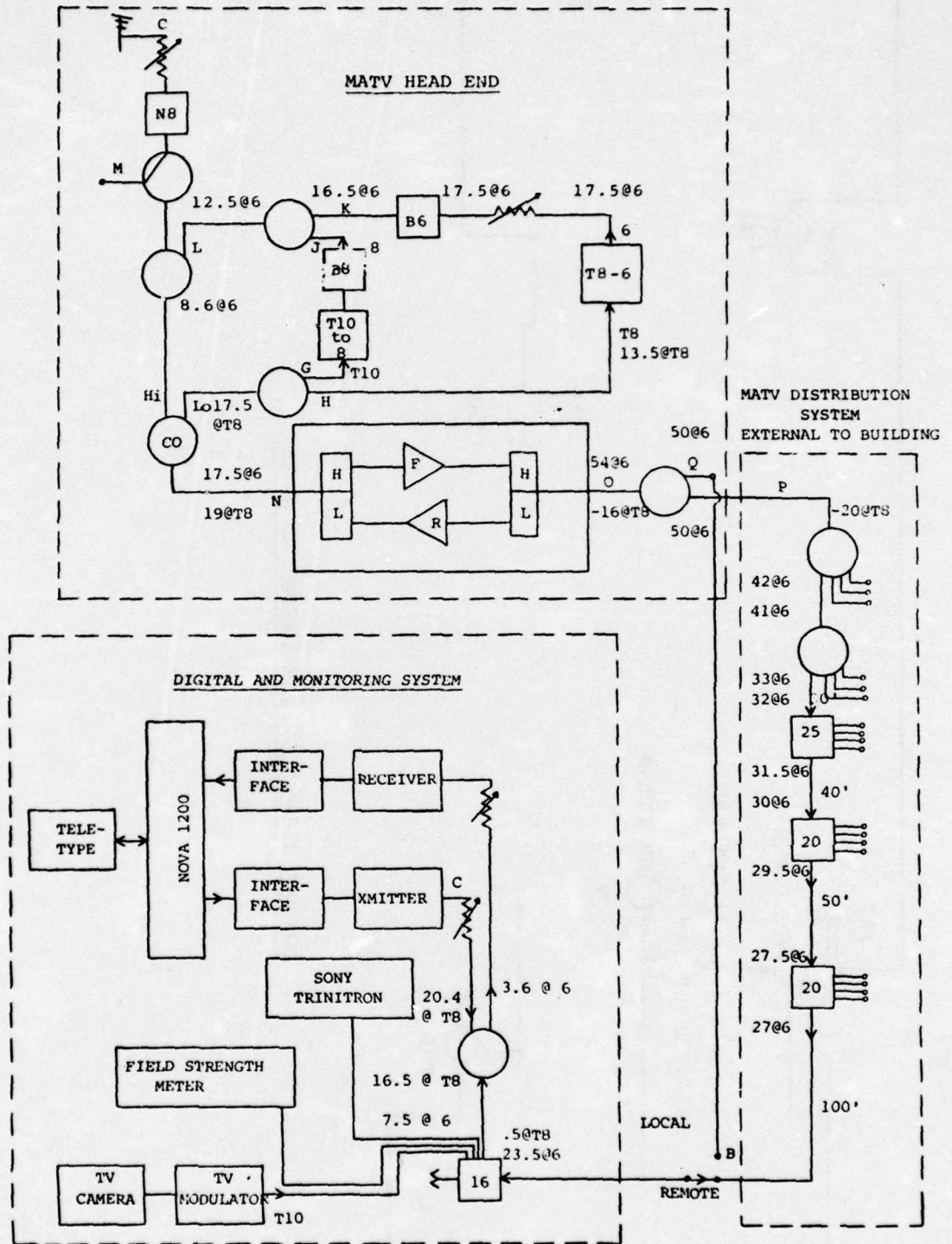

FIGURE 4.1b: FINAL SYSTEM CONFIGURATION

Singal levels in dBmV @ T8, Channel T8
 @ 6, Channel 6
 @ 8, Channel 8

LEGEND

Network Analysis Corporation

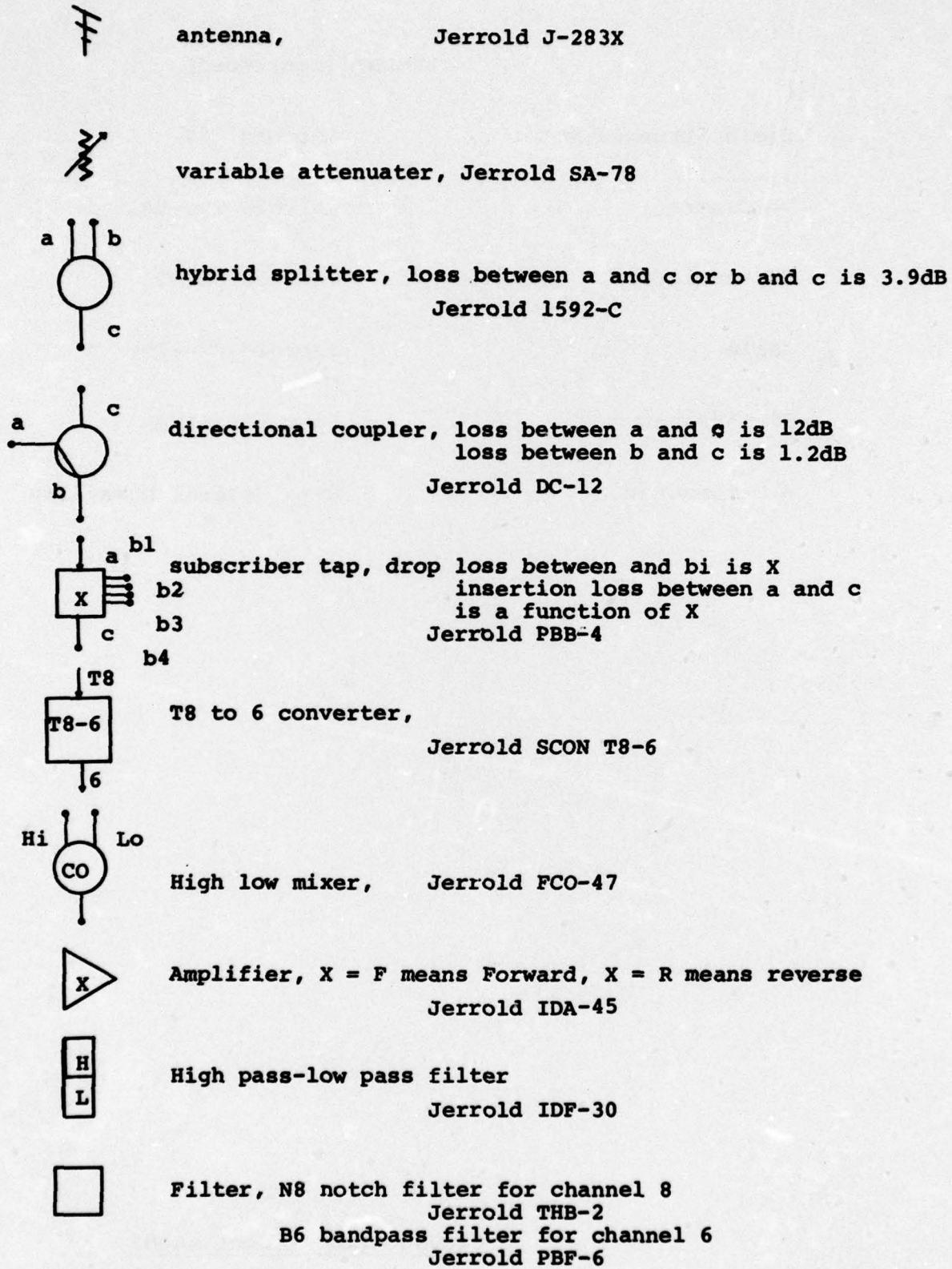

FIGURE 4.1c: LEGEND FOR SYSTEM CONFIGURATION

LEGEND (continued)

Field Strength Meter	Jerrold 727
TV Camera	Jerrold TVC-501
TV Modulator	Jerrold UMT10
Cable	Jerrold RG-6/U
TV Receiver	Sony Trinitron
Minicomputer	Data General Nova 1200

FIGURE 4.1c: (Continued)

to send and receive signals on a local loop of only a few feet. Hence, with the given configuration, we can insert video signals from off the air and from a TV camera at a number of different points, and we can insert digital data at several different points. We can run a variety of experiments in order to determine, in both the upstream and downstream directions, the interaction of digital and video signals.

4.1.2 Digital System Operation

We next describe the course taken by data in order to illustrate how the various elements of this system interrelate in performing the task of sending packet information through the cable system.

The three major elements in the data path are the minicomputer, the modem and the cable system. The computer can be further divided into software components and hardware components. The initial component in this path is a section of computer software called a 'SEND ROUTINE'. Data is then passed to another computer software element, the packet executive, where an EXECUTIVE OUTPUT ROUTINE communicates with a computer hardware device, a TRANSMIT INTERFACE. The transmit interface communicates with a TRANSMIT MODEM which passes the information to the cable modulator on Channel T8. The information is then passed through several active and passive components in the computer system to the RECEIVER MODEM. From the receiver modem, the components are utilized in the reverse order of the transmit side. The entire sequence is listed below.

1. SEND ROUTINE.
2. EXECUTIVE OUTPUT ROUTINE.
3. TRANSMIT INTERFACE.

4. TRANSMIT MODEM.
5. T8 MODULATOR.
6. CABLE SYSTEM.
7. T8 to CHANNEL 6 CONVERTER.
8. CABLE SYSTEM.
9. CHANNEL 6 DEMODULATOR.
10. RECEIVE MODEM.
11. RECEIVE INTERFACE.
12. EXECUTIVE INPUT ROUTINE.
13. INFORMATION GET ROUTINE.

The information to be sent is input on a teletype and the characters are assembled by a send routine until a complete section of information has been assembled. In the demonstration program, this was limited to one packet, but could be extended to allow multiple packet transmissions.

The executive output routine is called and this routine makes certain that there are an even number of characters in the data, and adds a DLE-STX to the front end of the message and a DLE-ETX to the end of the data. This executive output routine then initiates a core starting address, a maximum length count and the data break transfer of the character string to the transmit interface. The transmit interface signals the modem that a message is ready for transmission

and, after acknowledgement from the modem, sends out a number of SYN characters. The number of SYN characters is determined by a hardware strap on the transmit interface. The interface then initiates the direct transfer from the computer memory of the characters in the message, always keeping two characters ahead to ensure that there is no loss of synchronization. Upon detecting the DLE-ETX sequence, the transmit interface appends a checksum computed by the hardware and a final fill byte. The modem is then signalled to terminate the transmission and the executive output routine is informed of the transmit termination along with any errors which may have occurred. An external switch on the transmit interface forces an incorrect checksum computation for testing purposes.

The modem upon receiving the transmit request, signals the T8 modulator to turn on the carrier and presents the pseudo-NRZ code to the modulator. The bit sequence transmissions, which occur within the modem, are independent of character length, position or any other attribute of the data itself. When the modem receives the end of transmission signal from the transmit interface, it waits for the T8 modulator.

The T8 modulator produces a carrier with a center frequency at 14.75MHz. The modulator produces symmetric side bands which can be limited to 5 MHz without loss of information. This T8 channel signal is then introduced to the cable system and passes through the reverse amplifier into the loop-back element in the system - a T8 to CH6 converter.

The role of the T8 to CH6 converter is to simulate a head-end packet system. This converter loops back and re-introduces into the system the identical message that it received. This loop-back message is then transmitted through the cable system in a forward direction on Channel 6.

The Channel 6 demodulator operates in a conventional fashion to present a signal to the receive modem. The receive modem, upon detecting a carrier, tries to lock, in a phase lock loop of 1 MHz, to the demodulator signal. When this lock in has been successfully achieved, it raises a line (RD) to the receiver interface until the phase lock loop loses hold of the signal at the end of the transmission. The receive data (RD) comes true within 93 microseconds from initiation of the T8 modulator turn on. This ensures a packet "capture" within 100 microseconds. As with the transmit modem, the receive modem performs no operation on the data and communicates with the receiver interface on the basis of three signals: the RD previously described, the receiver clock used by the interface to sample the data, and the data itself.

The receiver interface looks for a SYN pattern on the input data at each bit time after receiving an RD from the modem. As soon as this pattern is detected, the interface searches for a number of SYN characters in sequences determined by strapping on the interface board. The interface then scans for the initial DLE-STX and when that is found, takes it off and begins passing data to the computer until the DLE-ETX sequence is determined. Immediately following this final sequence, the next three bytes of data are compared by hardware with the checksum computed by the receiver interface and if there is a mismatch, the receiver checksum error flag is set. The final fill character allows an interval between the last valid data and termination of the carrier.

The executive input routine is then notified that data is in core and checks the various error conditions from the receiver interface. Provided the data has been correctly received, it passes the information to the get routine. The get routine is the final element in the path of this packet and has an option to type out the received data on the teletypewriter.

4.1.3 Goals of Tests

The tests are partitioned into two main groups, component verification and system tests. The purpose of testing the components is to determine their precise operating characteristics. In particular they must meet design specifications but should not exceed them by so much that they become atypical of commercially operating systems. Once the operating characteristics are verified we can properly interpret the results of subsequent tests and can extrapolate the results to other system configurations. These verification tests are covered in Section 4.2 on the MATV system, and Section 4.3 on the modem.

The system tests themselves are broken into two main sections, qualitative performance verification and quantitative performance verification. In the qualitative verification the frequency assignments and signal patterns are examined to tune the system and determine proper assignments for filters, pads, converters and taps. Again the goal is to meet system specifications in a typical MATV environment and to establish some limits for system operation. In the quantitative system tests the most crucial aspects of system performance are addressed. In Section 4.6.2 we describe the timing tests and in Section 4.6.3 we consider the signal interaction tests. The timing tests are critical because we are working with a random access packet mode. At a megabaud rate of data transmission a thousand bit packet is a millisecond long. For effective operation the receiver section of the modem must be able to acquire a packet in less than a tenth of a packet, i.e., .1 msec. As will be seen the modem tests verify that this is within the capability of the modem. But it must also be verified that this performance can be achieved for a signal passing through the MATV system. In particular the amplifiers, converters and filters add amplitude distortion and even more important, group delay distortion. For the

transmission of color video signals the group delay is well controlled in MATV and CATV systems at the video carrier frequency and the color burst frequency, but is relatively poor at other frequencies.

The signal interaction tests are concerned with the ultimate measure of system performance by which one measures feasibility or infeasibility. Can the video and data signal levels be adjusted so there is no visual interference with video signals, so that bit and packet error rates are acceptable and so both signal levels are compatible in range and sensitivity with the constraints of commercial MATV and CATV systems?

4.2 MATV TESTS

The verification tests must be run on the MATV system itself. The MATV system characteristics must be determined and we must be assured they are comparable to typical commercial systems. Furthermore a precise knowledge of the characteristics are necessary in order to be able to interpret and extrapolate subsequent measurements. The key parameters are:

- . Number of video channels and signal levels.
- . Noise.
- . Amplifier characteristics.

4.2.1 Number of Video Channels and Signal Levels

The test system had eight off-the-air TV channels and FM plus the modem carrier on Channel 6. There was an additional channel from a hand-held TV camera on T10 which was converted to 8. The measured off-the-air signal levels at the antenna in dBmV were as follows:

<u>CHANNEL</u>	(dBmV) <u>SIGNAL LEVEL</u>
2	20
4	20
5	22
7	16
8	4
9	13
11	12
13	6

This channel occupancy and the signal levels are comparable to typical MATV systems. However, in a usual Metropolitan CATV system, the system is "loaded", carrying at least 20 channels. The effect of these additional channels is to create a number of beats or third order harmonics over the entire band of frequencies carried by the cable. These harmonics can be treated as wideband noise with respect to signal strength measurements. However, it is not unusual to find that, although a harmonic falls 55 dB below the picture carrier, it forms a multiple with the scan rate or color subcarrier so as to produce objectionable picture interference. These multiple beats might also increase the error rate although the modem has been specifically designed to guard against such interference.

4.2.2 Noise

One of the most critical parameters in the system is the noise level. Its characteristic "granular" or "snowy" type interference with video signals is quite noticeable in poorly designed systems and of course its logarithmic effect on bit error rates in data systems is well known. Because of its striking interference with video, noise is ordinarily one of the most carefully controlled parameters in an MATV/CATV system. Noise figures for amplifiers are usually down around 10dB and overall signal to noise ratios are about 40 to 45 dB. In our system the signal to noise ratio on all channels was measured to be better than 40dB.

The test set up included a two-way MATV amplifier with 6 subscriber taps and over a thousand feet of cable. Cascaded amplifiers will introduce additional noise into the system. However, reduction of the picture signal and modem signal was used to decrease the signal to noise ratio below the expected limits for a CATV system.

The level of impulse noise present in an urban environment is greater than that found at the test site. However, NAC has a large number of electronic devices, including card punch machines, mini-computers, data processing terminals, line printers, etc. This equipment can be expected to produce some impulse noise on the test system. In any case impulse noise is not a critical parameter for the system for two reasons. First it usually results in "flashes" on the TV screen. If these are random and do not occur too often they are far more tolerable than "snow". From the point of view of data transmission, the random access packet mode is extremely robust with respect to burst noise, since it usually results only in a retransmission of a packet.

4.2.3 Amplifier Characteristics

The most important element in the MATV distribution system is the amplifier. It provides the gain necessary for adequate signal power throughout the system. But it also is the prime contributor to system noise, cross modulation between channels due to poor rejection, intermodulation and signal distortion due to nonlinearities of gain. The characteristics of the amplifier were measured in a sweep frequency test. The results of these tests are shown in Figures 4.2a - e. The frequency response of the amplifier is shown in Figure 4.2a. The response is typical of MATV and CATV amplifiers in that the full 54 to 300 MHz is included in the pass band. Of course the gain is not constant but it contains only small variations within any 6 MHz video band, with very little variation in magnitude over the entire band. In fact, the curve is expanded vertically in Figure 4.2b to show a peak to valley deviation of less than 1/2 dB over the entire useful frequency band. The two curves represent the same measurement with the manual gain control changed by 1 dB. One point that is obvious from these figures is that if a

number of identical amplifiers with these characteristics are cascaded possible gain distortion would require an adequate automatic gain control system. Furthermore, with a cascade of amplifiers and long lengths of cable, slope compensation is required for the amplifier. This compensation was tested by adjusting the manual slope control from its minimum to maximum value giving a dynamic range of 4 dB maximum as in Figure 4.2c. This control is adequate to compensate for several hundred feet of cable with plug in equalizers compensating for the remainder.

One of the most important requirements on video electronics is that the return loss at the input and output of the amplifiers be at least 17 dB. Violation of this condition can result in "ghosts" on the TV screen and for data can result in unacceptable intersymbol interference. As seen in Figures 4.2d and e the requirement is violated above 270 MHz and below 54 MHz. Hence, the amplifier is only marginal above 270 MHz and might cause tuning and equalization problems for data sent in these bands. Even in the middle of the video band the input return loss varies greatly and at 180 MHz is just about 17 dB. The information in the figures is summarized in Table 4.2.

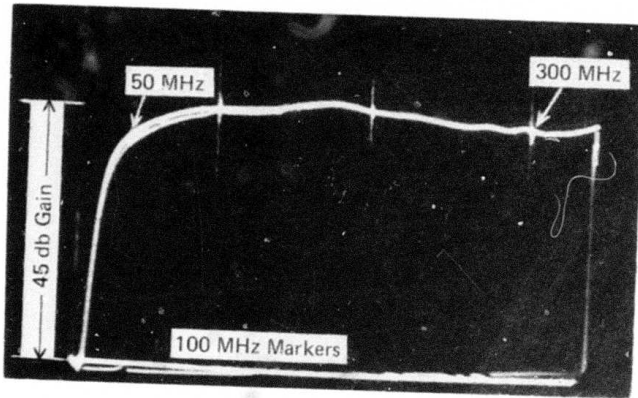

FIGURE 4.2a: IDA45 FREQUENCY RESPONSE

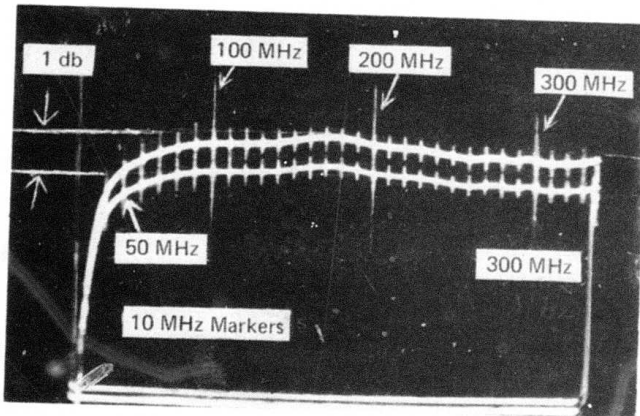

FIGURE 4.2b: IDA45 PEAK TO VALLEY CHARACTERISTICS

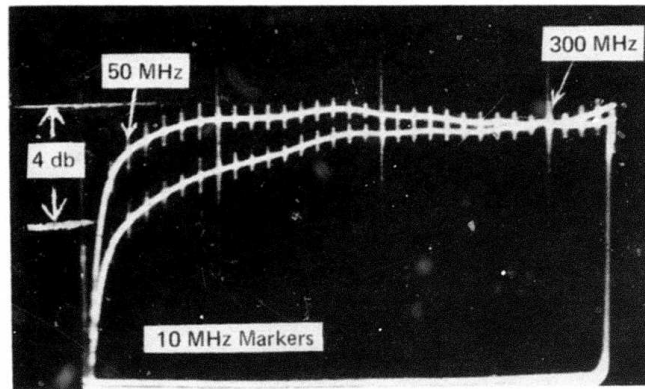

FIGURE 4.2c: IDA45 SLOPE CHARACTERISTICS

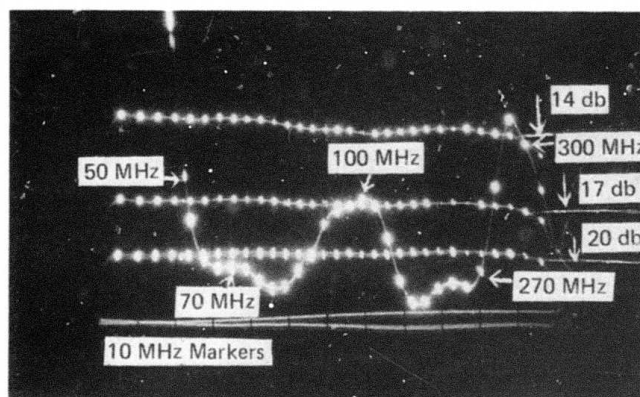

FIGURE 4.2d: IDA45 INPUT RETURN LOSS

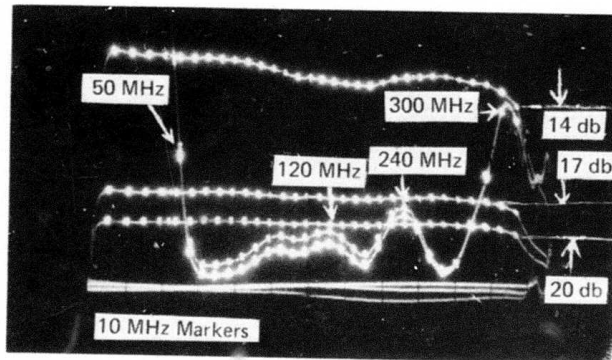

FIGURE 4.2e: IDA45 OUTPUT RETURN LOSS

Frequency Range	50 - 315 MHz
Gain Max	45 dB
Gain Control Linear	12 dB manual
Slope Control	4 dB maximum at 50 MHz
Flatness of Response	± 0.5 dB , 50 to 300 MHz
Noise figure	5db
Output Return Loss	14 dB at 300 MHz 17 dB at 240 MHz 20 dB at 120 MHz
Input Return Loss	14 dB at 300 MHz 20 dB at 272 MHz 17 dB at 180 MHz

TABLE 4.1: SWEEP FREQUENCY TESTING OF IDA-45 INTERNAL DISTRIBUTION FORWARD AMPLIFIER

Finally we should note a point of difference between MATV Systems and CATV systems which must be considered in performance evaluation. An MATV system uses unattenuated sound carriers as they are taken from the antenna; a CATV system uses approximately 15 dB attenuation of the sound carrier with respect to the video carrier. The effect of the stronger sound carrier would be to increase the error rate from the lower adjacent sound carrier, but it would also mask interference from the modem signal to the adjacent sound carrier. In our tests, we increased the modem signal 15 dB above the adjacent sound and detected no audio interference on any TV channel.

The overall conclusion of the MATV tests is that the system is in many ways typical of existing commercial systems and would provide a good test system.

4.3 MODEM TESTS

The function of the modem is to convert the digital signals presented by the interfaces into signals with characteristics matched to the 6MHz random access channel in the video bands of the MATV and CATV system. The modem is the primary determinant of digital system operation since its performance determines the data rate and the required signal levels. The parameters which must be verified are listed below.

- A. Signal Levels
 - Minimum output level
 - Input level range

- B. Timing
 - Accuracy of clocks
 - Acquisition time of less than 1/10 of a packet, i.e., .1 msec.

- C. Throughput

- D. Ability to operate at a signal to noise ratio of 40dB

- E. Bandwidth of modulated signal

Some details of the modem structure and operation are given in Appendix A. To explain our measurement suffice it to say here that the modem is designed to operate at one megabit per second using differential binary phase shift keying. The modem is constructed as a single device but the receiver portion is functionally independent

from the transmitter portion. This functional separation was further maintained by constructing the receiver computer interface on a separate board from the transmitter computer interface. The computer subroutines were, likewise, functionally separate so that the only common interchange between the receiver and transmitter was in the executive portion of the computer program. The transmit portion is carried over sub-Channel T8 with a 14.75 MHz carrier through the cable system to the head end where it is converted to Channel 6 with a 85.0 MHz carrier. This converter is functionally equivalent to a modem placed at the head end. Channel 6 is then carried in a forward direction to the same portion on the subscriber tap where T8 was introduced.

In the verification of modem operation the modem was looped back on itself through the local loop GIKL in Figure 4.1b with the switch B in local position. The signal data levels and clock pulses were monitored on an oscilloscope. Typical patterns are shown in Figures 4.3a and 4.3b for transmitted and received signals for an alternating set of zeroes and ones. Figure 4.3a shows data transmitted on the positive going edge of the clock. The measurements showed that at a megabit per second transmission rate the modulator output level was at least 30 dBmV and that the input to the demodulator could be anywhere from +20 dBmV to -36 dBmV.

The 30 dBmV output is sufficient to provide the -36 dBmV anywhere in the system for modem pickup. The input dynamic range of +20 dBmV to -36 dBmV is large enough so that a modem can be placed anywhere in an existing CATV system. Furthermore the 30 dBmV output is well below the 50 dBmV typical output from the head end amplifier. Hence, it should be quite adequate for protection of TV reception. The modem was able to transmit at the megabit data rate with signal to noise ratios well below 40 dBmV, the usual MATV environment. Finally, the spectrum of the unmodulated modem signal is shown

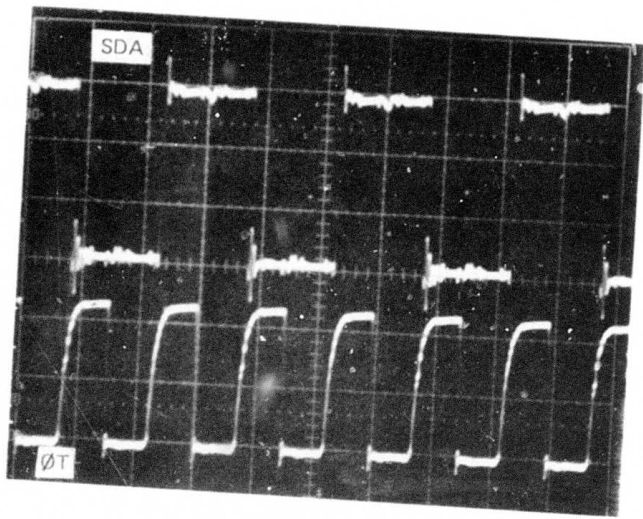

FIGURE 4.3a: TRANSMITTER CLOCK (LOWER SIGNAL)
AND SENT DATA (UPPER SIGNAL)

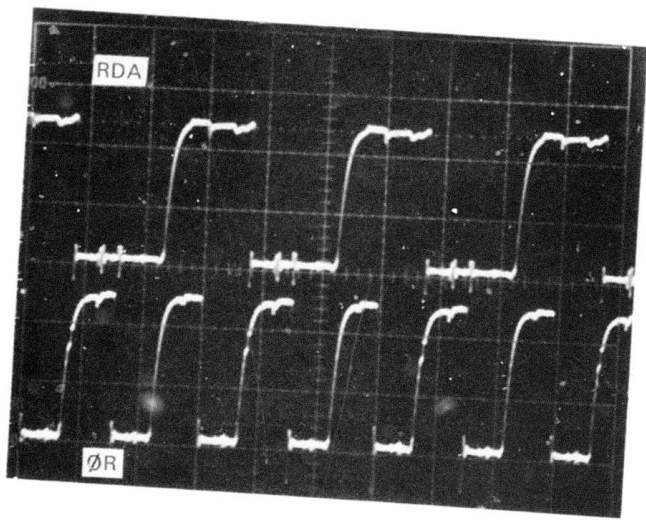

FIGURE 4.3b: RECEIVER CLOCK (LOWER SIGNAL)
AND RECEIVED DATA (UPPER SIGNAL)

in Figure 4.3c. 99% of the power is in a 4 MHz band. The two peaks at the left of the figure are the audio and part of the video signal from the adjacent Channel 5. The spectrum is sufficiently restricted to be compatible with video signals. Hence, the results of the preliminary modem tests are satisfactory. The further aspects of system timing, synchronization, acquisition, interference and error rates are covered in Section 4.4, Systems Tests.

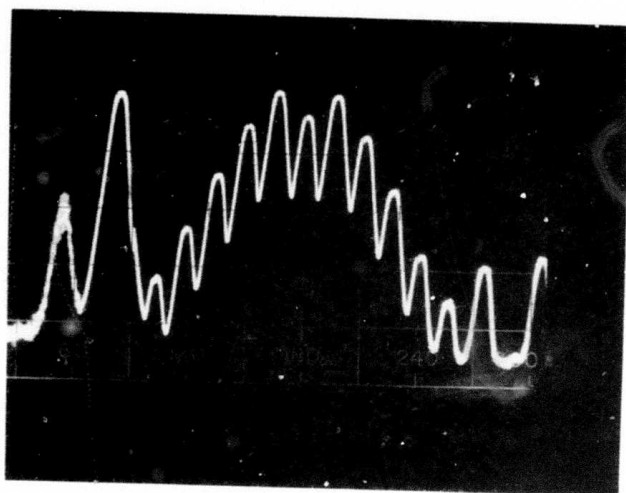

FIGURE 4.3c: SPECTRUM OF MODEM UNMODULATED SIGNAL

4.4 SYSTEM TESTS

Having completed the verification tests for the system components, three phases of system tests were performed:

- . Tests for qualitative performance verification.
- . Timing tests to verify synchronization, acquisition and delay times.
- . Testing of packet data and video interaction under a range of test conditions.

4.4.1 Tests For Qualitative Performance Verifications

The interaction of the individual components as a system involves a tuning and adjustment stage to achieve acceptable system performance. This phase is an integral part of the system design since in carrying it out we determine acceptable ranges of system operation and areas of marginal or unacceptable system performance which must be avoided or circumvented in commercial operation.

We will describe the sequence of steps taken to make the system operational and the concomitant effects on commercial operation.

The primary conclusions are:

1. The modem sensitivity to input and output signal levels is low enough so that no special precautions need be taken on commercial systems.

2. An unexpectedly strong signal was received on Channel 8, which provided unacceptable interference with the signal from the TV camera. This required the addition of a trap for Channel 8 at the antenna. Traps would probably be needed in a commercial system.

3. The performance of the frequency converters was unacceptable in that they produced undesired signals at many extraneous stray and harmonic frequencies. Additional band pass filters were required and would also be needed in a commercial system.

In order to understand the spectrum analysis of the video bandwidth one must keep in mind standard patterns for TV signals. For ease of reference these are included in Table 4.2 and Figures 4.4a and b below. In Figure 4.4b, we give the spectrum of a video signal, in Figure 4.4b we illustrate this spectrum for Channel 4 and in Table 4.2 we give the standard video frequency allocation [RHEINFELDER, 1971].

Figure 4.5a shows, at a tap, the full video spectrum from Channel 2 through Channel 13 with FM in the midband between Channels 6 and 7, and with digital data on Channel 6. Figure 4.5b shows an expanded version of Channels 2, 4 and 5. In Figure 4.5c we examine the spectrum for Channel 2 while data is being sent on Channel 6. Figure 4.5d shows the same spectrum for Channel 2 with no data being sent on Channel 6. In Figure 4.5c we can see very significant interference from the data signal into Channel 2. In fact, the picture was "unviewable" on Channel 2 under these conditions. The culprit in this case was the T8-6 converter

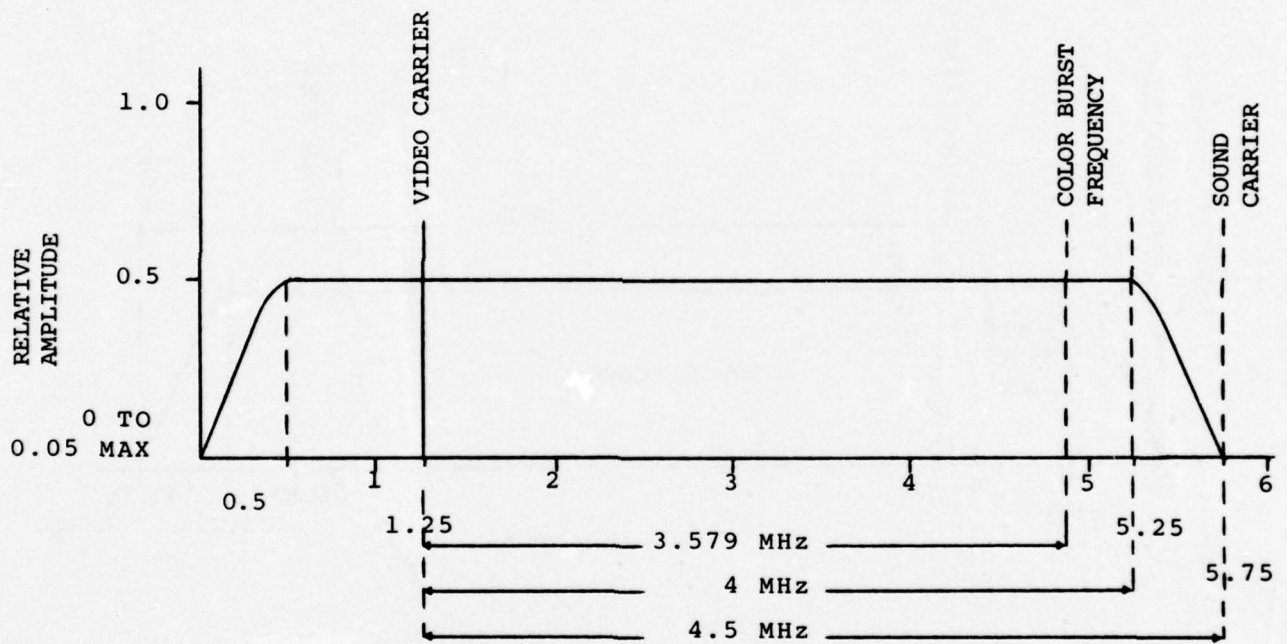

FIGURE 4.4a: STANDARD TV CHANNEL SHOWING SOUND-VIDEO CARRIER RELATIONSHIP

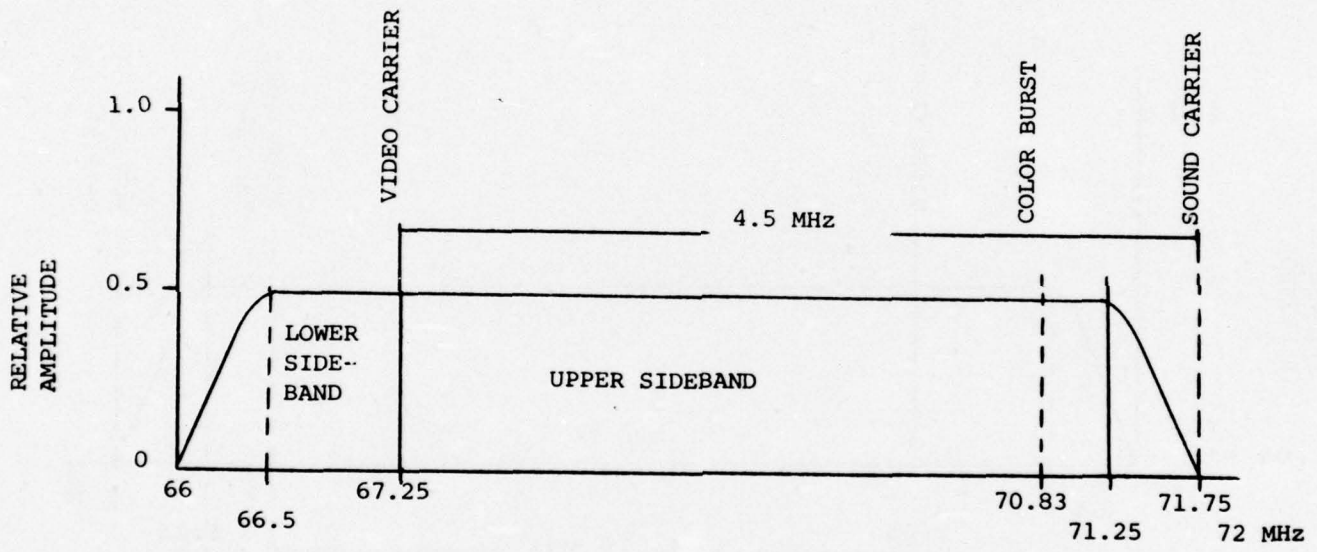

FIGURE 4.4b: CHANNEL 4 SOUND-VIDEO CARRIER RELATIONSHIP

CHANNEL	BAND	PICTURE CARRIER	SOUND CARRIER
	MHz	MHz	MHz
2	54-60	55.25	59.75
3	60-66	61.25	65.75
4	66-72	67.25	71.75
5	76-82	77.25	81.25
6	82-88	83.25	87.75
7	147-180	175.25	179.75
8	180-186	181.25	185.75
9	186-192	187.25	191.75
10	192-198	193.25	197.75
11	198-204	199.25	203.75
12	204-210	205.25	209.75
13	210-216	211.25	215.75

TABLE 4.2: TELEVISION BROADCAST CHANNEL FREQUENCIES

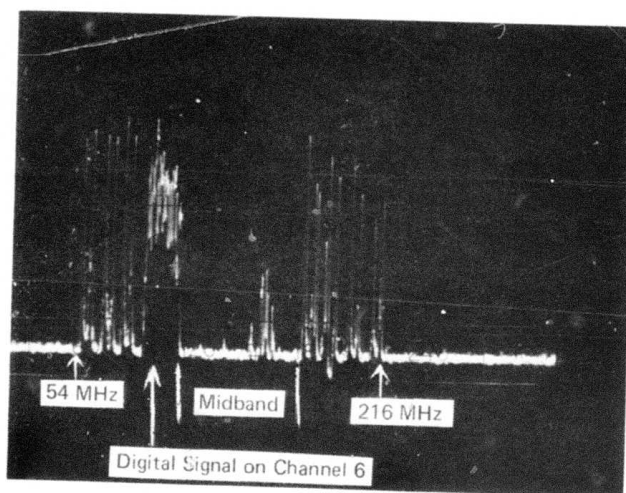

FIGURE 4.5a: FULL VIDEO SPECTRUM AND DIGITAL SIGNAL

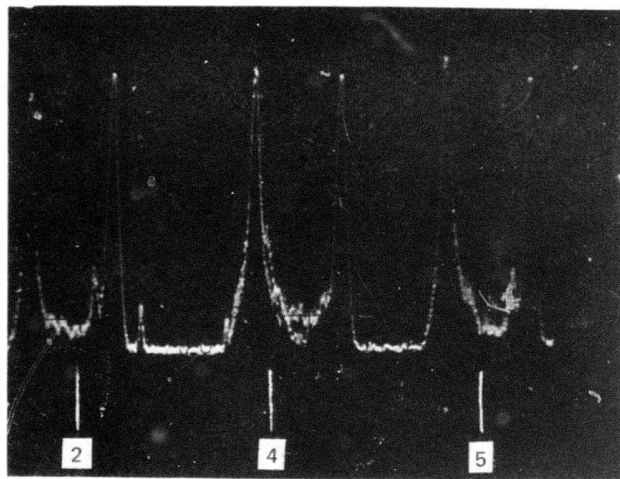

FIGURE 4.5b: CHANNELS 2, 4, 5 WITH DATA INTERFERENCE ON CHANNEL 4

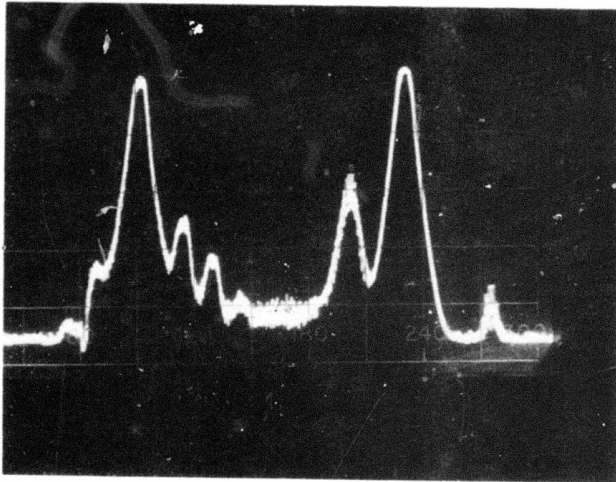

FIGURE 4.5c: CHANNEL 2 WITH DATA ON CHANNEL 6 AND NO FILTER

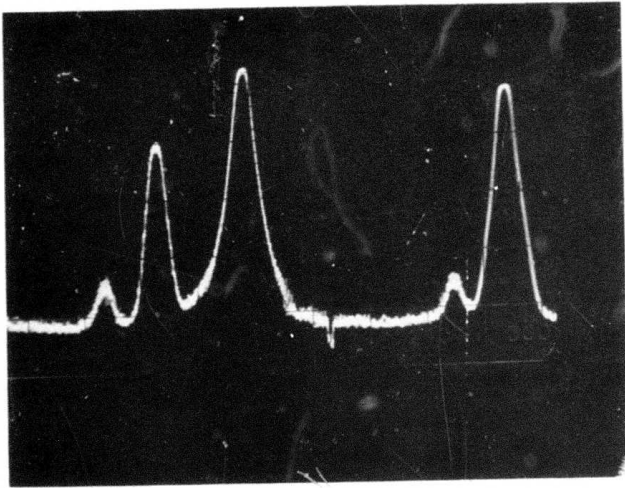

FIGURE 4.5d: CHANNEL 2 WITH NO DATA ON CHANNEL 6

which was producing signals and beats at extraneous frequencies. Channel 6 bandpass filters were inserted at the outputs of the converters. The spectrum for Channel 2 with the data on Channel 6 became identical with that shown in Figure 4.5d.

Figure 4.6a shows the spectrum for the midband and for Channels 7-13 with the TV camera and T10-8 converter on. The TV picture on Channel 8 resulting from this spectrum is shown in Figure 4.6b. It shows a "zero beat" interference, that is two signals differing in carrier frequency by, at most, a few KHz. The cause is a high input signal on Channel 8 from the antenna superimposed on the signal from the camera and the T8-6 converter. After insertion of a trap at the antenna for the off-t e-air signal on Channel 8, the resulting spectrum on Channel 8 for the unmodulated signal from the camera is shown in Figure 4.6c.

Next, the signal levels in the system were adjusted for optimal performance and the dynamic ranges for the system were determined. All signal levels were measured with a Jerrold 727 field strength meter. The measurements were checked against a spectrum analyzer at several levels both for the modem and the picture carriers.

Since the modem modulation involves a change in frequency rather than amplitude, the signal level remains constant independent of the pattern of information transmitted. The voltage used for the dBmV calculation is then the RMS value.

In the packet transmission, the modem signal is present for only a fraction of the time. For the purpose of measuring the modem signal level with the 727 field strength meter, it was necessary to enter a special computer program which transmitted an essentially continuous packet of information namely, 64,000 bit packets with a 99% duty cycle. This continuous mode was also used in determining the effects of the modem signal on the picture quality, since it represents the worst possible case.

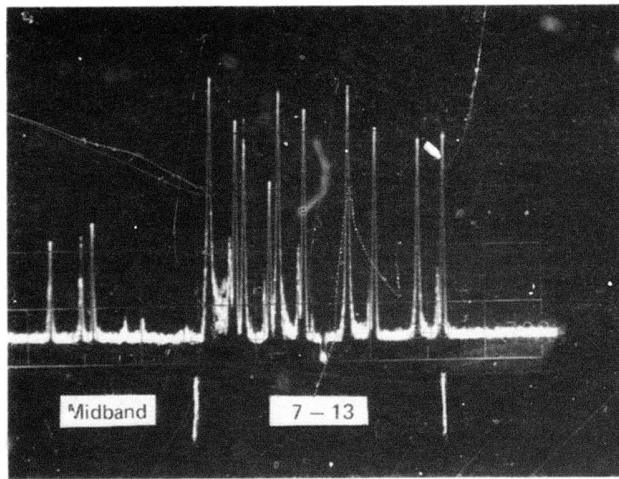

FIGURE 4.6a: MIDBAND AND CHANNELS 7-13 WITH TV CAMERA ON

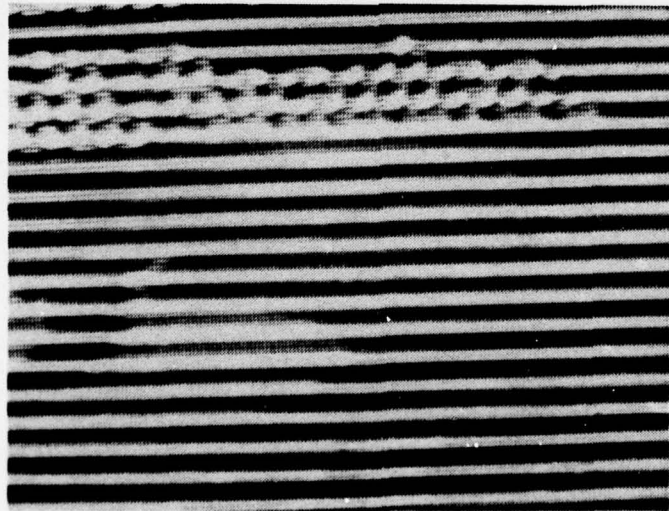

FIGURE 4.6b: ZERO BEAT INTERFERENCE RESULTING FROM SPECTRUM IN FIGURE 4.6a

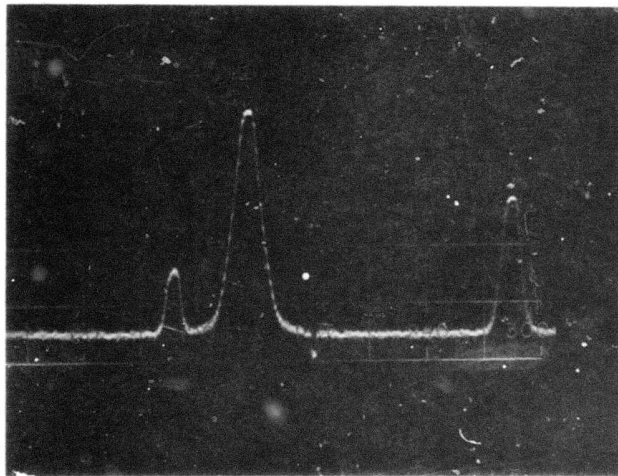

FIGURE 4.6c: UNMODULATED TV CAMERA SIGNAL ON CHANNEL 8 WITH OFF-THE-AIR
CHANNEL 8 TRAPPED AT ANTENNA

The level of the TV picture depends upon the actual information being transmitted. A largely black picture transmits considerably more energy than a relatively white picture. In order to overcome this difficulty, the industry has adopted the following standard which we found to be acceptable for comparison of the ratio of picture signal level to modem signal level. The signal level at the SYNC tips is assumed to be the maximum amplitude of a sine wave representing the picture signal level; therefore, the RMS value of the SYNC tip is used for the calculation of picture signal level.

The forward amplifier gain was adjusted to 45 dB at Channel 6 and the reverse gain was adjusted to be 35 dB at Channel T8. The signal level of the picture was changed by inserting fixed pads at the antenna input. To prevent saturation of the modem input the signal strength on the T8-6 converter was attenuated by an adjustable pad at the point where Channel 6 is introduced into the system. The final system configuration is shown in Figure 4.1b, with the modem represented by its independent receiver and transmitter sections.

With the system as shown in Figure 4.1b, video sources were turned on and packets were sent by the minicomputer through the transmitter interface and the transmitter looped through the system to the receiver, through the receiver interface and back to the modem. The packets were 512 bits in length or 512 msec and the interval between packets was uniformly distributed between 16 and 32 msec.

The packets were first looped back through the loop without the amplifier, then with the amplifier and finally through the farthest subscriber tap and back. The packets were correctly received at the given setting. A description of the software used in the tests is

given in Appendix B. Typical software outputs used to verify system performance and to carry on the subsequent detail experiments are given on the next page with the explanation of the printouts underneath. The receipt of packets and the messages under appropriate conditions, of course, comprised the ultimate functional verification of the system.

SYSTEM MESSAGES

1 ***NAC'S PACKET CABLE SYSTEM IS INITIALIZED***

2 ENTER THE TIME IN OCTAL TICS BETWEEN EACH TRANSMISSION
20

CHECKSUM ERROR

3 WORD COUNT ERROR

DESTINATION ERROR

TIMEOUT

4 THIS IS AN AUTOMATICALLY GENERATED PACKET

5 AUTOMATIC LOAD ON CABLE HAS STOPPED

ENTER THE TIME IN OCTAL TICS BETWEEN EACH TRANSMISSION
A
INPUT MUST BE OCTAL REENTER BOTH DIGITS.

6

IA
INPUT MUST BE OCTAL REENTER BOTH DIGITS.

7 ***RUBOUT***

Explanations

1. Greeting message when system is started.
2. Preempt message to begin automatic packet sending - Control T
3. Errors that are detected.
4. This is a packet that has been sent through the coaxial cable
5. Control Z
6. The input is checked for octal numeric.
7. Pressing rubout key causes this message.

4.4.2 Timing Tests

As indicated in the introduction the measurement of system timing is critical since packets must be acquired in less than a tenth of a packet. The two main goals of the measurement are to establish that the modem capabilities are adequate and the second is to measure actual timing for data signals transmitted through the system. The parameters measured are:

1. Modem delay.
2. Time between clear-to-send and request-to-send.
3. The sum of these two times.
4. Time between clear-to-send and next request-to-send.
5. Synchronization of clocks.

The significance of each measurement is explained below.

The first set of measurements were to establish the modem delay and the system delay, the sum of which would give the time to acquire a packet. Figure 4.7a shows received and sent data sent through the looped back system. With each division at 1 μ sec this shows a modem delay of 3.7 μ sec to be used for the rest of the measurements in this section. Figure 4.7b shows the delay of clear-to-send after asserting a request-to-send. Clear-to-send comes true 96 μ sec after request-to-send. This 96 μ sec plus the 3.7 μ sec modem delay gives a packet acquisition time of 99.7 μ sec. For a thousand bit packet this is 1/10 of a packet. This is confirmed in Figure 4.7c which shows the received data on the top trace and request-to-send on the bottom trace. The pattern word is one, followed

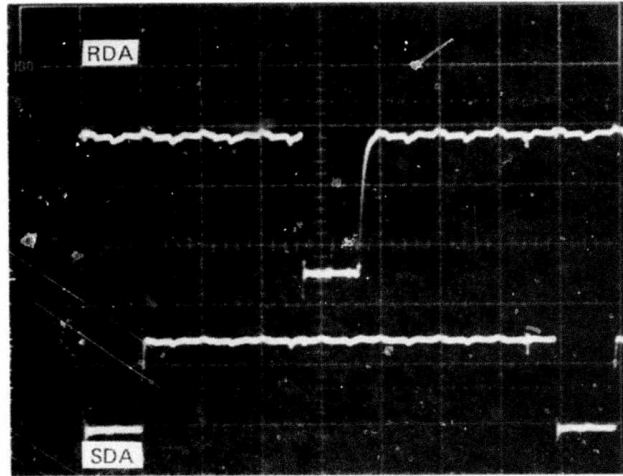

FIGURE 4.7a: MODEM DELAY OF 3.7 μSEC. SENT AND RECEIVED DATA
1 μSEC/CM.

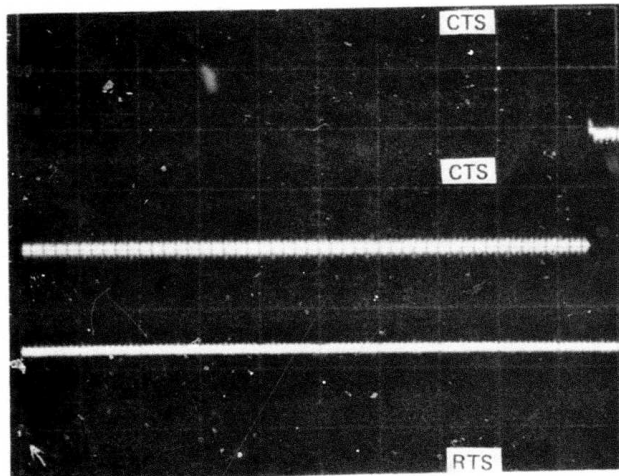

FIGURE 4.7b: CLEAR-TO-SEND (UPPER SIGNAL) 96 μSEC. AFTER REQUEST-TO-SEND (LOWER SIGNAL)
10 μSEC/CM.

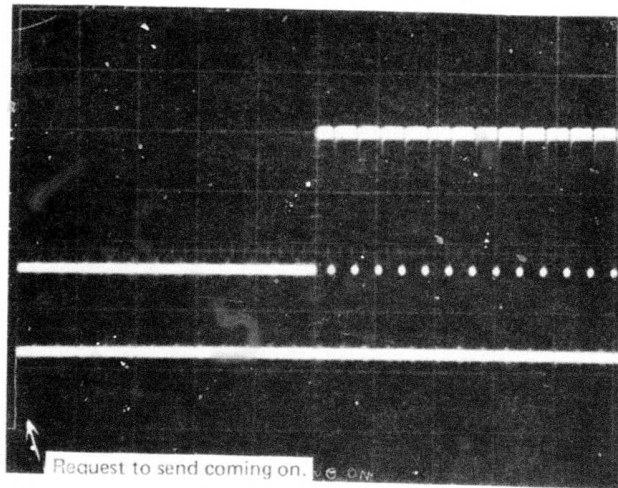

FIGURE 4.7c: RECEIVED DATA (UPPER SIGNAL) GOOD 100 μ SEC AFTER RTS (LOWER SIGNAL)
20 μ SEC/CM.

by 7 zeroes and the sweep speed is 20 μ sec per cm. This picture shows the received data is good exactly 100 μ sec after request-to-send comes true.

The purpose of the next measurement is to ascertain that the modem could send packets at a sufficiently high rate to accommodate close to a 1 megabit/sec rate. Figure 4.8a shows the clear-to-send and request-to-send at 100 nsec/division. Clear-to-send comes false 150 nsec after request-to-send. In other words, the modem is released to transmit another packet 150 nanoseconds after the completion of the previous packet. Hence for a 1 millisecond packet this is about another 15% overhead.

As a final test of system performance we examined the synchronization of the transmitter and receiver crystal clocks since this is the ultimate measure of signal resolution and system performance. Figure 4.8b shows the receiver clock and the transmitter clock. The relationship between these two clocks was observed to be within 2% at all times. It should be noted that although the picture shows the receiver clock leading the transmitter clock by approximately 280 nsecs, in actual fact this is due to a phase shift and the transmitter clock leads the receiver clock by 7.28 nsecs. An error in synchronizing the receiver clock of 10 to 15% would have been acceptable so that the stability is very well within specifications. In an actual CATV system variations in group delay might require additional compensation to guarantee synchronization. Although the requirements on a CATV system are very precise for the chroma and luminescence signals and are limited to 20-40 nanoseconds, at frequencies other than these two the group delay might well be 120 nanoseconds.

The over all conclusion of the timing tests is that the modem performs over the MATV system well within acceptable limits.

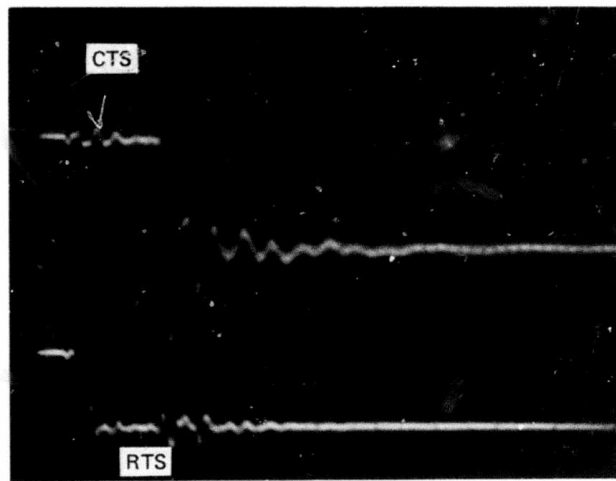

FIGURE 4.8a: CLEAR-TO-SEND (UPPER SIGNAL) AND REQUEST-TO-SEND (LOWER SIGNAL)
500 nSEC/CM.

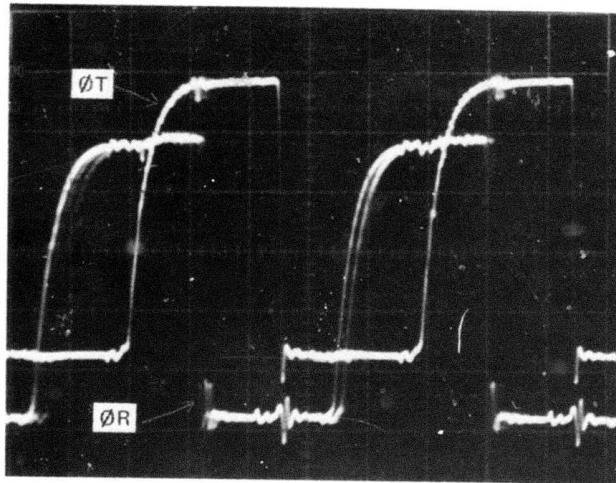

FIGURE 4.8b: RECEIVER CLOCK (UPPER SIGNAL) AND TRANSMITTER CLOCK (LOWER SIGNAL)

4.4.3 Signal Interaction Tests

The final, and most important tests were concerned with the applicability of the MATV and CATV medium for the transmission of packet data. The questions that had to be answered were the following:

- . Operating through the MATV system with constrained signal levels for "worst case" data patterns will the data signals be sufficiently undistorted for packet data transmission?
- . For a range of data signal levels which do not interfere with video transmission what are the error probabilities?
- . For data signal levels which yield acceptable error rates is there interference with reception of video signals?

In order to determine signal distortion and reception of "worst case" data patterns two data patterns were used, 5000 ones followed by 5000 zeroes and then 5000 zeroes followed by 5000 ones. These are ordinarily difficult patterns for a modem to detect because the detecting circuits tend to become biased toward zero or ones. However, the patterns were detected correctly. The sent and received patterns are shown in Figures 4.9a and b, for 5000 ones followed by 5000 zeroes. In Figure 4.9c we see the first one bit after 5000 zero bits. In all cases rise times and fall times of less than .2 μ seconds are indicated for a transmission through the MATV system.

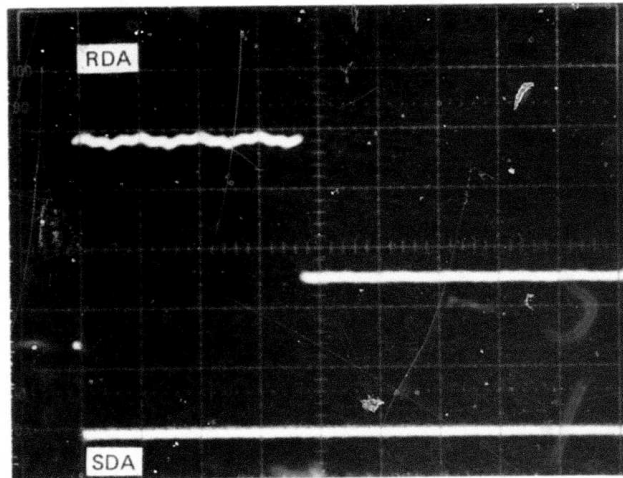

FIGURE 4.9a: RECEIVED (UPPER SIGNAL) AND SENT DATA (LOWER SIGNAL) 5000 ONES FOLLOWED BY 5000 ZEROES, LEADING EDGE OF DATA PATTERN

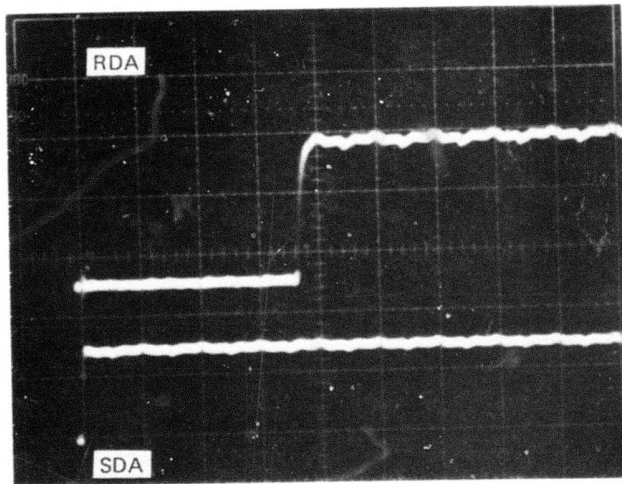

FIGURE 4.9b: RECEIVED (UPPER SIGNAL) AND SENT DATA (LOWER SIGNAL) 5000 ONES FOLLOWED BY 5000 ZEROES, BACK EDGE OF DATA PATTERN

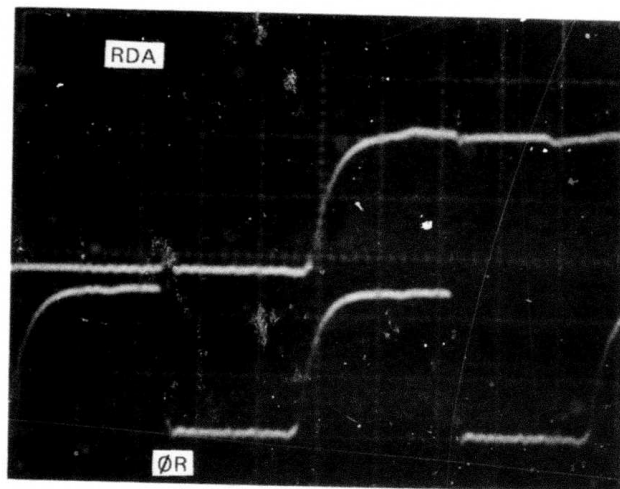

FIGURE 4.9c: FIRST ONE-BIT (UPPER SIGNAL) AFTER 5000 ZERO BITS AND RECEIVER
CLOCK (LOWER SIGNAL)

The real effect of interference on the TV signal is the decrease in picture or sound quality. In the case of the packet data transmission the interference from the data signal on Channel 6 was most apparent in the adjacent channel cross modulation visible on Channel 5. The interference pattern resulted in stripes across the screen as shown in Figure 4.10. The presence of visual disturbance was readily detected by turning the modem off and on and noting whether the interference bands appeared at all. It was determined that with a signal level for the data equal to the picture level no data interference was present. This was true for 512 bit packets as well as with almost continuous data transmission using 65,000 bit packets and a 99% duty cycle.

The modem interference is measured as the number of errors in a standardized message transmission experiment. This standardized experiment involved the transmission of 2^{16} , or 65,536 packets. Each packet had a total composition of 512 bits and was transmitted with an interval between packets that varied uniformly between 16 and 32 msec. The total time for each experiment was approximately 20 minutes.

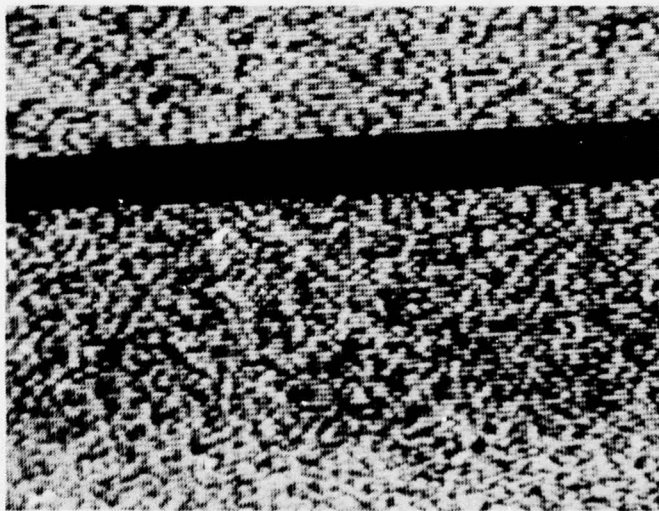

FIGURE 4.10: INTERFERENCE OF PACKETS WITH VIDEO SIGNAL WITH REDUCED TV
SIGNAL AND BOOSTED DATA SIGNAL

The composition of each packet follows:

<u>BYTES</u>	<u>FUNCTION</u>
4	SYNC
2	DLE, STX
8	Header
44	Data
2	DLE, ETX
3	Checksum
<u>1</u>	Fill
64	TOTAL BYTES

Since each byte contains 8 bits, the resulting 512 bits transmitted at 1 MBaud takes approximately 0.5 msec. This yields a transmission duty cycle of approximately 2%.

An experiment was terminated if any error count was greater than 30% of the packets indicated; otherwise, the error counts at the end of the experiment were recorded. In cases in which zero errors were counted, a special switch on the modem transmit interface was used to intentionally generate incorrect checksums in order to validate system operation. All program error counts were thoroughly checked and verified.

The signal level was measured at the adjacent subscriber's tap. An additional pad between the subscriber's tap and the modem receiver was used to vary the modem signal level. In all these measurements no deterioration in the picture quality was detectable. The results of varying picture and modem signals independently are displayed in Table 4.3 and plotted in Figure 4.11.

<u>PICTURE ON CHANNEL 5</u> (dBmV)	<u>DATA ON CHANNEL 6</u> (dBmV)	<u>% ERRORS IN 65,000 PACKETS</u>
+8	+3	0
+8	-7	0
+8	-13	.05
+8	-31	.45
+8	-33	> 20
-2	+13	0
-2	+ 3	0
-2	- 7	0
-2	-22	0

TABLE 4.3: SYSTEM ERROR RATES

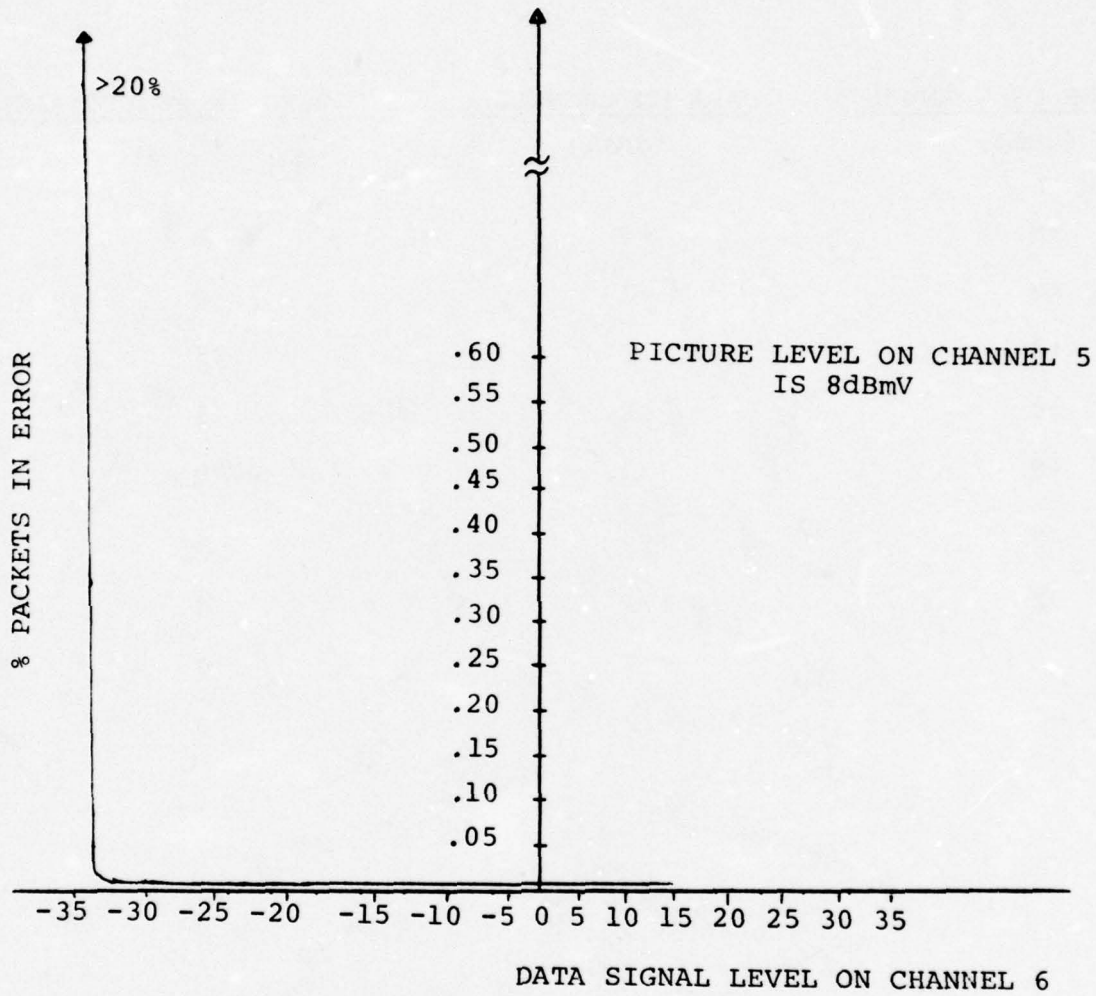

FIGURE 4.11: % OF PACKETS ERRORS VS. DATA SIGNAL LEVEL ON CHANNEL 6

The data shows that in the normal range of TV signals at the tap approximately -2 dBmV to +8dBmV the data can be kept at approximately the same level as the video or can easily be kept 20 dB below it with negligible error rates. Even with a video signal level of 8dBmV and a data signal of -33 dBmV, a 41 dB difference, the packet error rate is only .45%, resulting in negligible contribution to retransmission compared to the number of retransmissions due to overlapping packets. The bit error rate indicated by no packet errors in 65,000 packets is better than 10^{-8}

4.5 CONCLUSION

The purpose of the tests on the in-house system (Figure 4.12) was to demonstrate the viability of random access packet data transmission on MATV systems and by extrapolation to CATV systems. This extrapolation was accomplished by determining the limits of performance of the system and showing they were compatible with those of existing commercial CATV systems.

All tests run on the system gave positive results. The characteristics of individual components were well within the limits of acceptable performance in terms of allowable signal levels, timing errors, synchronization problems and performance relative to noise thresholds.

Signal levels were tested which are totally compatible with requirements set by commercial television operators. Functional performance was verified and packet error rates of better than one in 65,000 were achieved with data signal levels more than 20 dB less than video signals. Furthermore, even with signal levels (measured on a packet or continuous transmission basis) equal to video signal levels no picture interference was detected. The frequency spectrum of the present data signal peaked in the center of the Channel 6, 6 MHz band. If the center frequency were shifted closer to the band edge it would be more similar to video spectra and as a result of TV rejection bands and filters would cause even less interference in adjacent channels.

In addition to these promising results several caveats must be considered. First, the present tests were run with a very high quality TV receiver. If a poorer set were used the cross modulation would be slightly greater and data signal levels would be more restricted. But the dynamic range of the modem is so large that this would cause no problem.

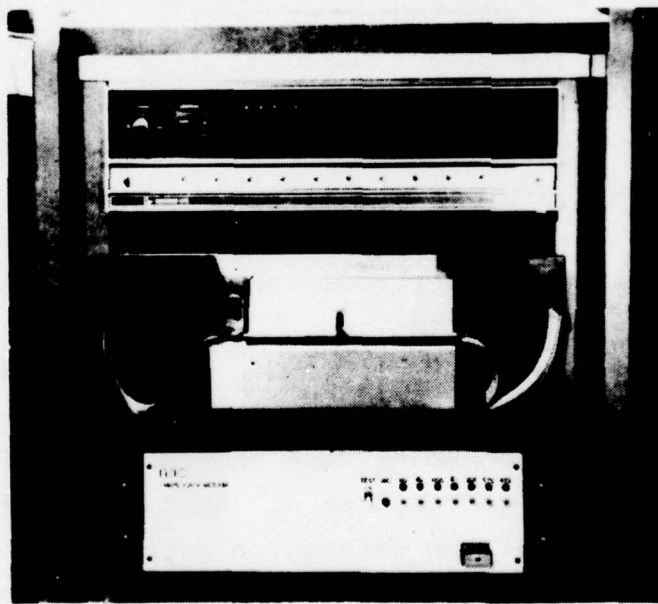
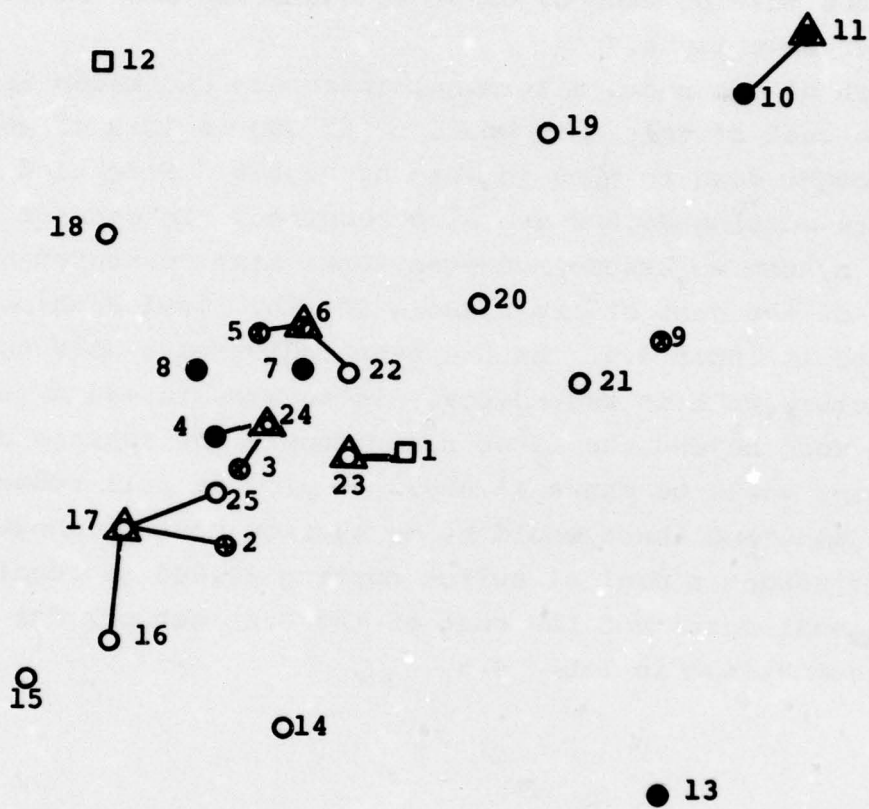

FIGURE 4.12: MODEM, MINICOMPUTER, INTERFACES, AND PAPER TAPE READER

The second caveat applies primarily to commercial MATV and older CATV systems, and is more serious. Data users may find cable system reliability quite poor when compared with the common carrier facilities that they are used to. One of the major problems with data transmission on MATV and CATV systems is that there is virtually no redundancy in these systems. Most present systems do not even have standby primary power. Alternate routings are not available in case of system "catastrophe". There are no Government or industry minimal standards for acceptable performance; hence, performance will vary from system to system. Many old systems were built to extremely loose specifications on noise and cross-modulation and have serious reflection problems because of the use of unmatched subscriber taps. Fortunately, many newer systems in large cities and new buildings are required to meet more exacting standards.

The ultimate safeguard for data transmission is the TV signal itself. The modem and interface characteristics have been shown to be so good that with a cascade of amplifiers pure video interference will be seen on the system before there is significant data interference. Hence, if the system performance is acceptable for video transmission it should be acceptable for random access packet data transmission.

The economics of data transmission on CATV can be established by considering a design for the same Washington area as considered in Chapter 2 for conventional technology and for Packet Radio. The maximum radius of a single CATV system or "hub" is about 20 miles, hence only small parts of the Washington area can be covered by CATV systems. Of the 25 terminals, 5 hubs, in typical CATV urban settings could cover 14 nodes. The groupings of the nodes are shown in Figure 4.13 with the triangles representing the head ends of the CATV hubs. The groupings and head end locations



- △ HEAD END NODE FOR HUB OF CATV SYSTEM
- T ○ TERMINAL(S)
- H ● HOST(S)
- HT ● HOST(S) AND TERMINAL(S)
- BN □ BACKBONE NODE

FIGURE 4.13: GROUPING OF NODES FOR TYPICAL CATV SYSTEMS

were determined by the probable locations of "typical" commercial CATV systems. For example, node 11 rather than 10 was chosen as a head end since it is closer to the center of a "downtown" urban area. The connections among the hubs, and the connections to the backbone nodes must be made by other technologies such as telephone lines or microwave links.

For each of the nodes a terminal interface and modem is required. The cost of this unit would be \$3,200 in lots of 200 and could be brought down to \$500 in lots of 10,000. Five head end minicomputers costing \$4,000 are also required. To connect the hubs of the CATV system we assume a conventional star connected network. The summary of the cost of the network for the local Washington area is summarized in Table 4.4. As has been indicated a CATV system is a tree structure with no redundancy. If we were to add a redundant path from a node beyond the first power supply the average cost in CATV equipment would be about \$3,000. To provide full redundancy back to the head end there would be an average cost of about \$24,000. With any redundancy a digital switch costing \$2,800 is required. These additional costs and the cost of the star network for dual homing are summarized in Table 4.5.

	PURCHASE UNIT [\\$] PRICE	NUMBER OF UNITS	MONTHLY COST [\\$]	TOTAL MONTHLY COST
TERMINAL INTERFACE AND MODEM	\$ 3,200	14	187	\$ 2,616
HEAD END MINICOMPUTER	\$ 4,000	5	234	\$ 1,170
SUB TOTAL				\$ 3,786
CONVENTIONAL STAR HARDWARE AND LINE COST				<u>\$22,400</u>
				\$26,186

TABLE 4.4: COST OF DIGITAL CATV EQUIPMENT WITH NO REDUNDANCY

	PURCHASE UNIT [\$] PRICE	NUMBER OF UNITS	MONTHLY COST [\$]	TOTAL MONTHLY COST
A. REDUNDANT CATV EQUIP- MENT FOR POWER SUPPLY BYPASS	3,000	9	175	1,575
B. REDUNDANT CATV EQUIP- MENT FOR PATH TO HEAD END	24,000	9	1,404	12,636
C. DIGITAL SWITCH	28,000	9	164	1,476
D. ADDED CONVENTIONAL STAR HARDWARE AND LINE COST FOR DUAL HOMING				18,100
A + C + D				21,151
B + C + D				32,212

TABLE 4.5: COST OF DIGITAL CATV WITH REDUNDANCY AND DUAL
HOMING

REFERENCES

- [FRISCH, 1975] Frisch, I.T., "Technical Problems in Nationwide Networking and Interconnections," IEEE Trans. on Comm., Vol. COM-23, No. 1, January 1975, pp. 78-88.
- [RHEINFELDER, 1970] Rheinfelder, W.A., "CATV System Engineering," TAB Books, Blue Ridge Summit, Pa., 1970.
- [WAX, 1975] Wax, D., "Design Considerations for the ALOHA Radio Communication Sub-System," Technical Report B75-11, The ALOHA System, University of Hawaii, February 1975.

VOLUME 4

Chapter 4

APPENDICES

PRECEDING PAGE BLANK-NOT FILMED

APPENDIX A
DESCRIPTION OF MODEM OPERATION

The modem is similar in operation to the modem in the ALOHA Radio System [WAX, 1975]. Some of the details of the NAC IMPBS modem are described in this section.

Data transmission on the VHF channels is bit synchronous and packet asynchronous. The transmit and receive bit rate clocks are provided by the modem. The transmit clock rate is crystal-controlled to an accuracy of 0.01 percent, while the receive clock rate is locked to the rate of the received data. Figure 4.A1 shows the interface signals used between the modem and the data equipment, and also between the modem and the radio transceiver. All signals between the modem and data equipment are at TTL levels, as are the control signals between the modem and the radio transceiver. The transmit and receive baseband signals between the modem and radio transceiver are analog waveforms. The RTS flag is set by the data equipment when it is ready to send data. This flag is simultaneously transferred to the transmitter by the modem to turn on the RF carrier.

The modulation scheme used in the VHF channels is FM/DBPSK, wherein the radio frequency carrier is frequency modulated by a Differential-Binary-Phase-Shift-Keyed subcarrier tone. FM is used since readily-available commercial transceivers use this type of modulation. The noise-suppression characteristic of FM is useful in channels in which S/N ratios can be maintained above receiver threshold levels. The design incorporates matched filtering of the data signal to minimize bit error rate and correlation detection of the data sub-carrier tone to minimize packet detection false-alarm rate. Since the error-probability versus S/N ratio characteristic of the modem has been measured to be about one dB above the theoretical limit for DPSK, bit errors are caused primarily by impulses produced from the receiver's FM discriminator as its S/N

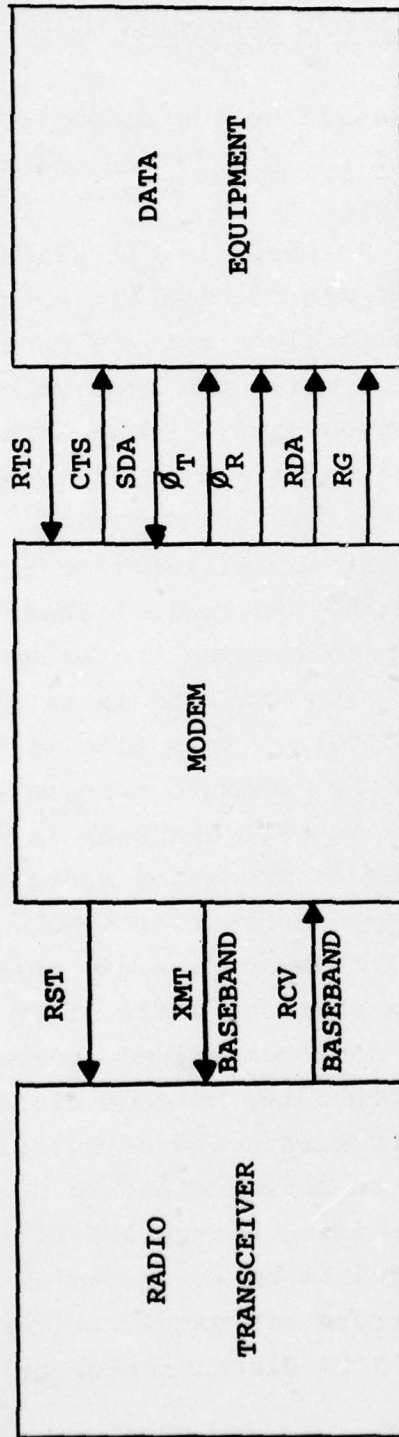

- RTS: REQUEST-TO-SEND FLAG
- CTS: CLEAR-TO-SEND FLAG
- SDA: SEND DATA
- RDA: RECEIVE DATA
- ϕ_T : TRANSMIT CLOCK
- ϕ_R : RECEIVE CLOCK
- RG: RECEIVE GATE (CARRIER ON)

FIGURE 4.A.1.1: MODEM INTERFACE SIGNALS

threshold is approached. Thus, the error-rate capability of the channel is basically FM threshold limited. A block diagram of the modem is shown in Figures 4.A.2 and 4.A.3.

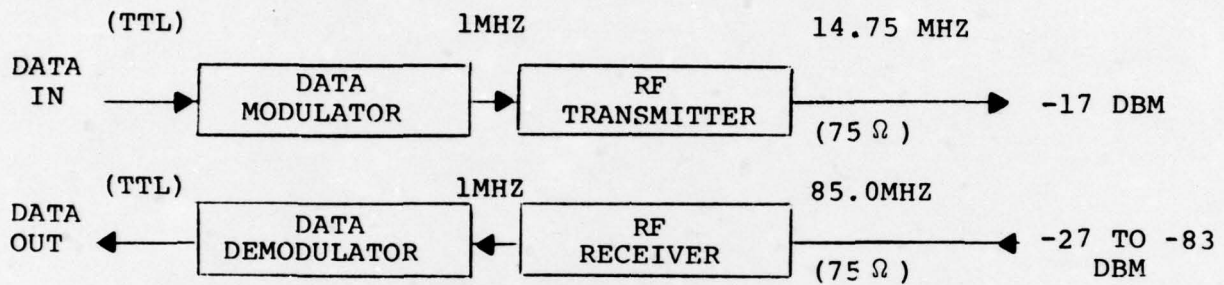

(FULL-DUPLEX CONFIGURATION)

FIGURE 4.A.2: GENERAL BLOCK DIAGRAM

APPENDIX B
SOFTWARE OPERATION

The software is written to run on Data General equipment. It is composed of system control programs, device handlers and an application program. The system has a supervisor that checks its queue of tasks to determine if a task should be activated. There is a routine that puts tasks onto this queue. Each task on the queue contains an entry address and a tic count. The tic count is decremented at each interrupt of the real time clock. When the tic count is zero then control is passed to entry address and that task is removed from the queue.

The system uses a table of pointers to a device control table for each device in the system. A device control table contains 4 items of information for each device, device code, interrupt disable mask, address of interrupt routine and the address of the open routine. Each time the system is started, control is passed to the open routine for each device in the system. This routine should set any pointers and reset any counters. The other entries in the device control table are used to service interrupts. When an interrupt occurs, control is passed to the interrupt service routine in the device control table whose device code matches the interrupting device code. If no match is found then a clear is issued for that device and a count is incremented. The interrupt handler saves the current interrupt disable mask, all the accumulators and the carry bit. It sets the interrupt disable mask from the device control table. When the device handler is finished servicing the interrupt, it should return control to interrupt return routine. This routine resets the interrupt disable mask, the accumulators and the carry bit. There is a stack of these save words. The levels of interrupts that can be nested depends on the amount of memory allocated to this stack.

The system also provides a random number generator. This routine generates a linear congruential sequence of the form $X(N+1) = (X(N)*A+C) \text{ mod } 2^{**}16$. This number is then added to a real time clock counter.

The teletype input is used to control the flow of data on the packet cable system. A control T will prompt the operator with a message to enter the time in octal between each transmission. The operator should then type in a 2 digit octal number. Messages are sent to the packet cable transmitter every XX tics of the real time clock. They will continue being sent until a control Z is typed. This will terminate this automatic transmission. If the operator types in a message up to 72 characters, followed by a return, then it will be sent to the packet cable transmitter. The operator has the option to print messages on the teletype as they are received from the packet cable receiver. The teletype output routine queues messages for print out on the teletype. It also controls output to the teletype including echo characters.

The packet cable transmitter controls all packets that are output on the coaxial cable. It has a queueing routine that queues packets for transmission. Each packet has a header that includes a retry count and a destination. A random transmission protocol similar to the ALOHA protocol is used. The time between packet transmissions is randomized over a period of 16 to 32 tics of the real time clock. The real time clock is currently in milliseconds. A count is kept of all transmissions and retransmissions.

The packet cable receiver controls incoming packets from the coaxial cable. The interface generates status for checksum and word count errors. A count is kept for each of these errors and also for successful packets. The packet destination is checked in the header. If it is zero then the packet is discarded. If it is one then it is queued for teletype output. If it is neither then an error is counted.

VOLUME 4

Chapter 5

**COMPARISON OF ALTERNATIVE TECHNOLOGIES
FOR LOCAL DISTRIBUTION**

5. COMPARISON OF ALTERNATIVE TECHNOLOGIES FOR LOCAL DISTRIBUTION

The results of the application of the three technologies, conventional, Packet Radio and CATV for the Washington, D.C. area are shown in Figure 5.1. Plotted is total monthly system cost for a complete design using each of the technologies. The lines labeled Design C1 and Design C2 represent the cost of the conventional technology designs. These costs are constant since the technology is fully developed and available tariffs are known. The other designs are either in the developmental or experimental stage. Therefore, the curves are plotted as a function of the piece of hardware contributing the major uncertainty to system cost. In the case of the Packet Radio system, this hardware is the PRU; and in the case of the CATV system, it is the modem-interface unit. For the Packet Radio nets, two designs are plotted for the cases of 3 ports and unlimited number of ports per PRU. Both Packet Radio designs provide reliability equivalent to the dual homing of conventional Design C2. For the CATV system, three designs are plotted. One corresponds to a CATV system with no added capability for redundancy. A second design corresponds to the case in which redundancy is provided so that there is an alternate path from each Host or terminal beyond the nearest power supply. Finally, the third design corresponds to the case of full redundancy in which an alternate path is provided from the Host or terminal back to the minicomputer at the head end.

For the CATV systems, the costs included are those of the digital equipment, the cost of CATV equipment to provide redundancy and the cost of the point-to-point lines to connect various CATV hubs. Not included is the rental fee charged by the commercial cable television company for use of two 6 MHz CATV channels. The cost evaluation of various technologies is done by comparison with the cost of conventional technology designs.

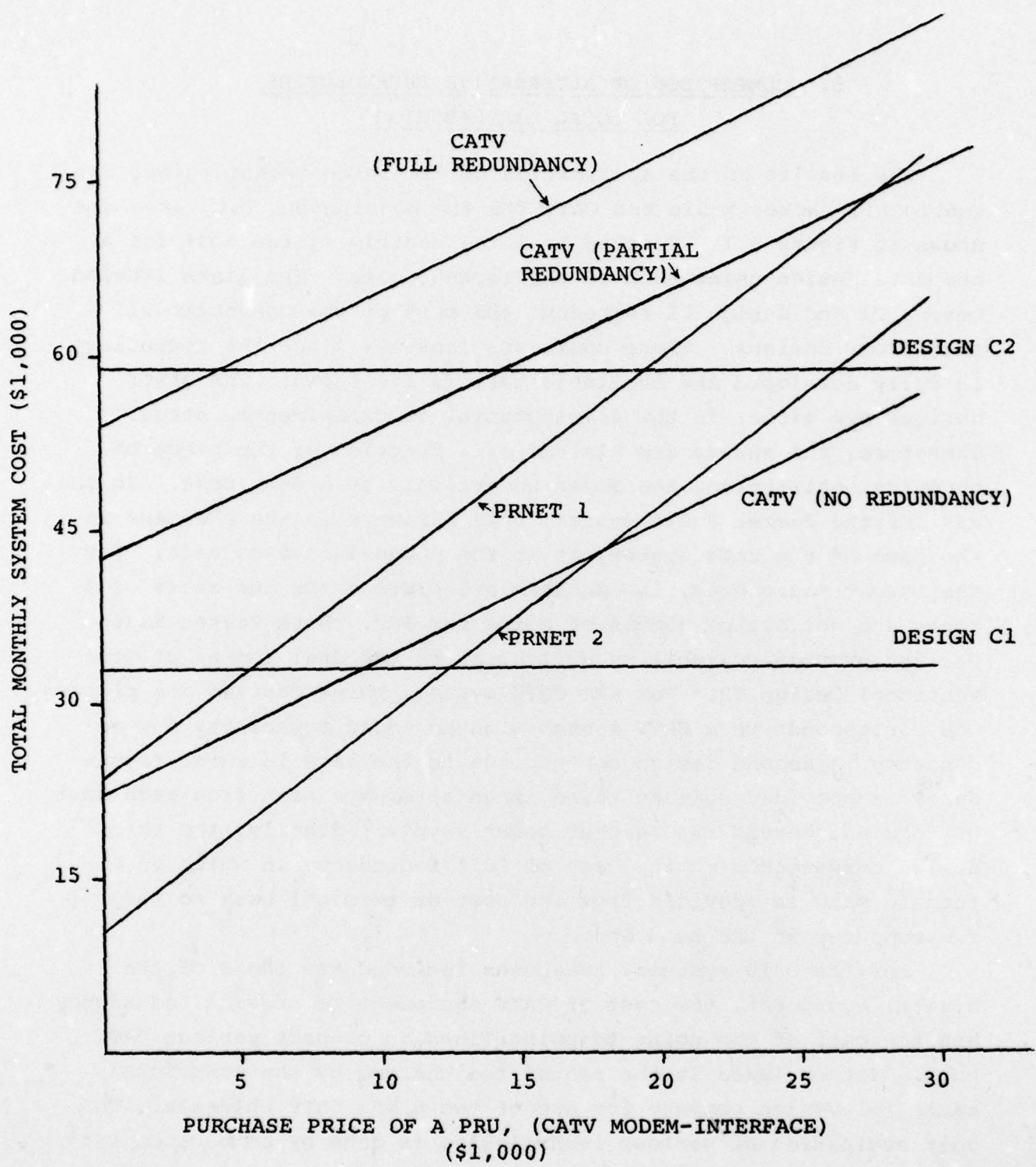

FIGURE 5.1: TOTAL MONTHLY SYSTEM COST VS UNIT PRICES

In the figure all designs correspond to dual homing except the conventional Design C1 and one of the CATV designs. We see that if a PRU could be built for less than \$12,000, the PRNET 2 would be cheaper than both conventional designs. For a PRU costing \$20,000, designs PRNET 1 and PRNET 2 would cost less than the conventional Design C2 using dual homing but more than the conventional Design C1. Since the expected cost of the PRU is less than \$20,000, the Packet Radio technology is a cost-effective alternative to the conventional technology. The expected cost of a CATV modem-interface is less than \$3,000. Hence, the CATV design with no redundancy is competitive with the single homing conventional design and the CATV design with partial redundancy is about \$15,000 per month less than the conventional design with dual homing. The conventional design with dual homing is very close in price to the cable television design with full redundancy. All of the designs with dual homing and expected hardware cost are in the price range from \$35,000 to \$60,000 per month.

The costs of the technologies are close enough so that in designing for different topologies, ranges and population densities, the tradeoffs could be turned around. The conventional technology would be more economical in areas with high population densities since multiplexing, multidropping, and polling techniques would reduce the cost per terminal. CATV systems are also cost-effective for very high density areas. In particular, as we have seen in the design for the Boston system, 100,000 terminals could be supported. Furthermore, the redundancy could be provided at a lower cost per terminal since a large number of terminals could share redundant paths. CATV systems are ideal for urban areas since the coaxial cable provides excellent shielding against urban noise. On the other hand, in urban areas the Packet Radio system would encounter technical difficulties with reflections and ghosting. Packet Radio is appropriate for large areas with small population densities and where mobile devices might be required.

Finally, in evaluating these technologies, the risk factor must be considered. The conventional technology is completely predictable, tariff rates are precise, and hardware is available. The Packet Radio technology is experimental with the first links presently being tested. Cable Television technology is well established and a number of small scale commercial data transmission operations are available. However, the technology for handling many thousands of terminals is still in the developmental stage.

DOCUMENT CONTROL DATA - R&D		
<i>(Security classification of title, body of abstract and indexing annotation must be entered when the overall report is classified)</i>		
1. ORIGINATING ACTIVITY (Corporate author) NETWORK ANALYSIS CORPORATION BEECHWOOD, OLD TAPPAN ROAD GLEN COVE, NEW YORK 11542		2a. REPORT SECURITY CLASSIFICATION Unclassified
		2b. GROUP None
3. REPORT TITLE SIXTH SEMIANNUAL TECHNICAL REPORT, FEBRUARY 1976, FOR THE PROJECT, "LOCAL, REGIONAL AND LARGE SCALE INTEGRATED NETWORKS," (VOLUMES 1 THROUGH 5)		
4. DESCRIPTIVE NOTES (Type of report and inclusive dates) SIXTH SEMIANNUAL REPORT, FEBRUARY 1976		
5. AUTHOR(S) (Last name, first name, initial) NETWORK ANALYSIS CORPORATION BEECHWOOD, OLD TAPPAN ROAD GLEN COVE, NEW YORK 11542		
6. REPORT DATE FEBRUARY 1976	7a. TOTAL NO. OF PAGES 880	7b. NO. OF REFS 140
8a. CONTRACT OR GRANT NO. DAHC-15-73-C0135	9a. ORIGINATOR'S REPORT NUMBER(S) SEMIANNUAL REPORT 6 (5 VOLUMES)	
b. PROJECT NO.	9b. OTHER REPORT NO(S) (Any other numbers that may be assigned this report) ---	
c. ARPA ORDER NO. 2286		
d.		
10. AVAILABILITY/LIMITATION NOTICES This document has been approved for public release and sale; its distribution is unlimited.		
11. SUPPLEMENTARY NOTES None	12. SPONSORING MILITARY ACTIVITY Advanced Research Projects Agency, Department of Defense	
13. ABSTRACT This technical report presents significant accomplishments in the development of computational techniques for network analysis and design, and the following cost/performance tradeoffs for data and computer communication networks: cost-effectiveness and economies of scale previously demonstrated for medium size packet switching networks (e.g., ARPANET) extend to large scale networks (e.g., 10 Mbs throughput). The most cost-effective architecture for large scale networks is a multi-level hierarchical structure. The cost of hierarchical networks is not very sensitive to number of backbone nodes near the optimum; the local access cost is approximately 50% of the total, and is the most sensitive component. For AUTODIN II, Phase I, the minimum cost backbone network configuration is a hybrid terrestrial-satellite net with six (out of eight nodes) ground stations, resulting in 25% savings in backbone line cost compared to a terrestrial net only. Packet Radio local access is a cost-effective alternative to conventional techniques, providing a Packet Radio Unit can be manufactured for \$20K-\$30K. Significant results are reported on Packet Radio network communication protocols, throughput-delay-reliability analysis, and stability control.		
14. KEY WORDS Computer networks, communication networks, terrestrial and satellite networks, packet radio networks, throughput, cost, delay, blocking, ARPA Computer Network, store-and-forward, packet switching.		