

AD-A035 955

ARMED FORCES RADIOBIOLOGY RESEARCH INST BETHESDA MD
EXTREMELY LOW FREQUENCY (ELF) VERTICAL ELECTRIC FIELD EXPOSURE --ETC(U)
JAN 77 N S MATHEWSON, S A OLIVA, G M OOSTA

F/G 6/18

UNCLASSIFIED

NL

| DF |
AD
A035955



END

DATE
FILMED
3-77

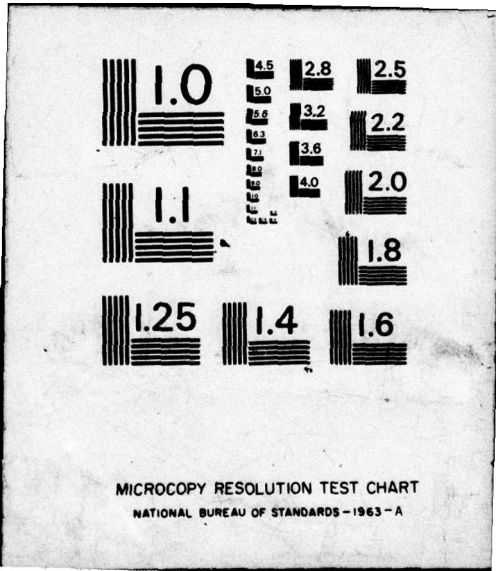

MICROCOPY RESOLUTION TEST CHART
NATIONAL BUREAU OF STANDARDS-1963-A

ADA 035955

11 January 1977

12 68p.

6
B S.

6

EXTREMELY LOW FREQUENCY (ELF)
VERTICAL ELECTRIC FIELD EXPOSURE OF RATS:
IRRADIATION FACILITY.

9 Final rept.

10

N. S. Mathewson,
S. A. Oliva,
G. M. Oosta
A. P. Blasco

COPY AVAILABLE TO DDC DOES NOT
PERMIT FULLY LEGIBLE PRODUCTION

ARMED FORCES RADIOBIOLOGY RESEARCH INSTITUTE
DEFENSE NUCLEAR AGENCY
BETHESDA, MD. 20014

DDC
RECEIVED
FEB 24 1977
RECEIVED

B 1473

DISTRIBUTION STATEMENT A
Approved for public release;
Distribution Unlimited

034700 LR

ACKNOWLEDGMENT

The authors gratefully acknowledge the valuable suggestions of Dr. J. F. Taylor (D.V.M.), Dr. M. E. Ekstrom (D.V.M.) and Mr. H. B. Cranford. Appreciation is also expressed to B. L. Imbach, D. P. Natale and the entire Logistics Department for their efforts in obtaining a timely and accurate fabrication of this facility. This project was sponsored by the U. S. Naval Medical Research and Development Command, contract number XSB09. Research was conducted according to the principles enunciated in the "Guide for Laboratory Animal Facilities and Care," prepared by the National Academy of Sciences-National Research Council.

ACCESSION for		
NTIS	White Section	<input checked="" type="checkbox"/>
DOC	Buff Section	<input type="checkbox"/>
UNANNOUNCED		<input type="checkbox"/>
JUSTIFICATION.....		
BY.....		
DISTRIBUTION/AVAILABILITY CODES		
Dist.	AVAIL. and/or SPECIAL	
A		

TABLE OF CONTENTS

Abstract

I. Introduction

II. Design and Description

1. Exposure Room

2. Exposure Chambers

3. Animal Cages

4. Signal-Generating and-Monitoring Systems

III. Electric and Magnetic Field Measurements

IV. Discussion and Conclusions

References

Appendix A. Equipment Specifications

Appendix B. IIT Research Institute Memorandum, 15 April 1975

Appendix C. IIT Research Institute Memorandum, undated

Appendix D. IIT Research Institute Memorandum, 15 October 1976

LIST OF FIGURES

Figure 1. Scale Drawing of the Top View of the Exposure Room

Figure 2. Perspective Drawing of two Exposure Chambers (contained in a rack)

Figure 3. Perspective Drawing of an Animal Cage

Figure 4. Block Diagram of the Signal-Generating and-Monitoring Systems

Figure 5. Schematic of Period Meter

Figure 6. Picture of the ELF Status Display Panels

Figure 7. Initial Field Map Locations within a Chamber

Figure 8. Exposure Chamber Wiring Locations

Figure 9. Final Field Map Locations

LIST OF TABLES

- Table 1. Summary of Chamber 45 Hz Vertical Electric Field Characteristics
- Table 2. Summary of 60 Hz Ambient Field Strengths with Chamber Lights, Room Heights and Blower Motor On
- Table 3. Average Total 60 Hz Field Strength per Cage
- Table 4. 60 Hz Electric Fields in the Vicinity of Electrical Appliances
- Table 5. 60 Hz Electric Fields at the Center of Various Rooms in a Typical Home

ABSTRACT

An extremely low frequency (ELF) vertical, electric field irradiation facility consisting of six identical exposure chambers is described. This facility was developed for biological research related to the U.S. Navy's proposed ELF Communications System, designed to establish worldwide communication with our submarine fleet. This irradiation facility is designed to study the possible bioeffects of ELF on 96 rats equally divided among the six exposure chambers and individually housed in specially modified nonmetallic cages. These cages are designed to minimally perturb the exposure field and provide accurate means to measure food and water consumption. Each exposure chamber can be independently operated up to field strengths of 1000 V/m (RMS) at any sinusoidal ELF frequency. At 45 Hz, the frequency chosen for this research, chamber cross-talk is less than -60 dB and the vertical electric field uniformity within the exposure area is $\pm 5\%$. A complete description of the ambient 60 Hz electric and magnetic fields is presented.

I. INTRODUCTION

The United States Navy is developing an Extremely Low Frequency (ELF) Communications System to allow communications with its submarine fleet.^{1,2} This system is another form of radiocommunication; however, it is quite unique in the frequency, antenna size and power that will be used.^{3,4} A general description of the electromagnetic radiation associated with this system and a comparison to other communications and electric power systems have been made in the Environmental Impact Statements on Sanguine.⁵ The exposure facility presented in this report is designed for biological research related to this communications system. As designed, this facility can generate sinusoidal vertical electric field strengths to 1000 V/m at frequencies to several hundred hertz.

Other vertical electric field exposure facilities have been developed such as those of Knickerbocker, *et al.*⁶, Noval, *et al.*⁷, and Marino.⁸ This facility is necessarily similar to these facilities, but with the following distinctive and important features:

1. ambient 60 Hz and exposure field strengths were documented;
2. no metal existed within the exposure volume;
3. test subject perturbation of the exposure field was studied;
4. test subject cannot touch the exposure apparatus;
5. test subject's environment was controlled and/or monitored to include temperature, relative humidity, air flow and filtering, cage requirements, limited access, etc.;

6. two identical signal-generating systems, and a switchover and alarm system provided increased reliability.

II. DESIGN AND DESCRIPTION

The exposure system is contained entirely within one room to insure that all experimental groups are maintained in similar environments. The qualities of the animal's total environment and the exposure field were equally addressed during the facility's development.

1. Exposure Room

The exposure room (Figure 1) was a standard laboratory 4.9 m by 7.4 m room, 2.7 m high, with its air-handling system modified for this research. Air was circulated within the room at 23 room-changes per hour with approximately 25% fresh air. All room air was filtered through an activated alumina and potassium permanganate filter (Purofil, Purofil Co., Chamblee, Ga.) and a high efficiency particulate air filter (HEPA-UL586, Flanders Filter, Washington, D.C.). A horizontal flow across the room was established by air entering through four registers (S of Figure 1) on one side of the room, and returning or exhausting through registers (R and Ex of Figure 1) at the other end of the room. This air-flow pattern was established to aid in scavenging stale air from the animal cages which were ventilated only from the top. This room was maintained under slight positive pressure, minimizing the introduction of unfiltered air.

Aluminum foil-covered fiberglass panels (Regiduct-RG, Certain-Feed Products Corp., Valley Forge, Pa.) were used to construct air ducts and to surround the blower and motor to minimize room noise. This type of ducting also reduced the amount of ferrous metal introduced into the room, a consideration because magnetic-field exposures were contemplated.

2. Exposure Chambers

Six exposure chambers were permanently numbered and contained in three racks within the exposure room as shown in Figure 1. Each rack consisted of two chambers (Figure 2) with each chamber holding sixteen cages. The irradiation chambers were horizontal, air-gap, parallel plate capacitors with the upper plate a 1.2 m (4 ft) by 2.4 m (8 ft) section of aluminum screen and the lower plate a similarly sized aluminum sheet, 0.16 cm thick. Electrical contact to the entire screen was maintained by framing the screen on all sides between two 0.48 cm x 1.90 cm aluminum bars. The upper plate height, adjustable to a maximum plate separation of 1 meter, was fixed at 46.4 ± 0.3 cm (S.D.) to accommodate the animal cages described in the next section.

Chambers were fabricated of wood with brass fasteners, except for the two exposure plates and a single 2.4 m (8 ft) fluorescent fixture used to improve the uniformity of chamber illumination. The ballast transformers of these fixtures were removed to the wall of the room to minimize 60 Hz magnetic fields. These fixtures were covered with aluminum screen to

minimize 60 Hz electric fields. Room and chamber lights provided illumination which at animal level ranged from 450 lx to 540 lx in the top chamber and from 350 lx to 370 lx in the bottom chamber.

Field fringing was reduced by employing a guard ring positioned around the periphery and midway between the chamber plates. The guard ring was connected to each plate by a 100 K Ω (\pm 1%, metal film) resistor. The bottom plate of each chamber was grounded to the signal generator and monitoring systems instrument ground.

3. Animal Cages

Nonmetallic cages designed to be adequate for a single rat⁹ and to allow convenient measurement of food and water consumption were produced. Each cage (Figure 3) was constructed from two standard 47.0 cm x 25.4 cm x 20.3 cm (18.5 in x 10 in x 8 in) polycarbonate rodent cages, with its bottom removed. The bottomless cage was inverted, placed on top of the other cage and secured with nonmetallic tape, which formed a cage 40.6 cm high by 25.4 cm wide by 47.0 cm long. A 45.7 cm by 22.9 cm section of 1/2-inch white plastic "egg crate" light diffuser material was secured to the top allowing for proper ventilation and retention of the test animal. In addition, this cage top prevents the animal from contacting the top chamber plate.

Food containers were wide-mouth, 250-cm³ ointment jars covered with a black phenolic cap in which a 3.8 cm-diameter hole had been cut to provide food access while preventing excessive spillage. This

container was fixed in the same position of each cage by an acrylic box, one side of which was made larger to provide a platform for smaller test animals to more easily obtain food.

Water was provided by a standard 250-cm³ glass bottle secured by a rubberband to an acrylic frame cemented to the end of the cage. A glass sipper tube entered the cage through a 1.3-cm hole below the water bottle.

4. Signal-Generating and Signal-Monitoring Systems

These systems provided the sinusoidal voltage used to drive any combination of the six chambers previously described and continuously monitored the system voltage. If a failure occurred in the signal generator system, the monitoring system would automatically switch to a backup signal generator; this would prevent an interruption of exposure or signal an alarm if this backup system also failed. A block diagram of these systems is shown in Figure 4, and equipment specifications are summarized in Appendix A.

a. Signal-Generating System

The signal-generating system consisted of two identical signal generators, one used as backup to the other. Each signal generator consisted of a sine-wave generator (Tektronix, SG502), power amplifier (Southwest Technical Products Corp., 270), and transformer (Triad, SX202). These subsystems were operated continuously into either the exposure chambers or an equivalent dummy-load as determined by the output

relays R1 and R2 (Figure 4). Operation into the dummy-load allowed the backup subsystem to stabilize, minimizing perturbations in the event of switch-over. Chambers were used either as exposure or control chambers by connecting or removing jumper wires J₁-J₆ (Figure 4). Potentiometers P₁-P₆ (Figure 4) allowed the field strengths in each chamber to be independently varied; this permitted several field strengths to be employed in a given experiment. Control chambers with their respective jumper wires removed had their potentiometers adjusted to the average value of the potentiometers of the exposure chamber, thus insuring similar source impedances.

b. Monitoring System

The monitoring system employed a digital voltmeter (Data Precision, 2440B1) which was switched to monitor the voltage from either signal generator subsystem or to any of the six chambers. The required voltage V_n to chamber n was obtained from

$$V_n = \frac{E}{d}$$

where E was the desired vertical field and d the plate separation (0.464 m). This equation is the standard equation for an electric field between two parallel charged conductors; however, it does not take into account the inhomogeneity of surface charge on the plates due to the large plate separation with respect to plate area and the presence of other charged objects nearby.¹⁰ Since an E-field probe to measure the 45 Hz chamber

field was not available, this equation was used to predict the plate voltage required for each chamber. These predicted voltages were set to within $\pm 0.5\%$, utilizing the digital voltmeter at the beginning and during experiments.

During normal operation the voltage to the chamber circuits was monitored by the digital voltmeter, which transmitted this value to the digital comparitor (LFE#4310, Appendix A) and logic network. If this voltage dropped to less than 95% of its experimental value for longer than 10 seconds, the comparitor and logic circuit either switched from the primary signal generator to the secondary signal generator or triggered an alarm in the event of a secondary system failure.

In addition, the frequency of each signal generator was adjusted and monitored to within $\pm 0.5\%$ by a period meter (Figure 5), employing a 1 MHz quartz crystal oscillator (Fork Standards, Inc., #AQ-DKIN-1). Frequency accuracy was routinely checked by measuring the 60 Hz line frequency which was never observed to deviate by more than ± 0.03 Hz. The voltmeter, period meter and all status lights as shown in Figure 6 were located at eye level in the equipment rack positioned beside the window of the entrance to the exposure room (Figure 1). This allowed these systems to be routinely checked from outside the room.

III. ELECTRIC AND MAGNETIC FIELD MEASUREMENTS

This exposure facility was designed to expose animals to sinusoidal vertical electric fields at ELF frequencies, specifically at 45 Hz. However, the normal environment of laboratories, offices, etc. have many sources of 60 Hz radiation such as the power lines, electric lights, electric motors, etc.⁵ With each room unique in electric sources inside or nearby, the importance of characterizing not only the irradiator field but other existing ambient fields cannot be minimized. To provide this information, an engineering team from the IIT Research Institute (IITRI), Chicago, Illinois, was requested to survey this facility and provide specific information concerning the ambient fields, the homogeneity of the 45 Hz chamber fields and the perturbations caused by the cages and animals. The three IITRI reports providing the information concerning this facility are presented as Appendices B, C, and D and summarized below.

Field strength data at specific frequencies were measured using Hewlett-Packard Wave Analyzers, Models 302A and 3581A; the electric fields were measured by a probe of IITRI design;¹¹ and the magnetic field data were obtained using a field probe consisting of a multiple-turn, random-wound coil on a cylindrical ferrite core. All field strength measurements in this report are reported in RMS units. The initial IITRI report (Appendix B) was performed at the ten numbered

locations in two chambers as shown in Figure 7. Figure 8 shows the location of 110 VAC power line to the chamber lights and the chamber transmission lines. These transmission lines were routed on the top of the ELF chamber racks back to the ELF instrument rack panel. The results of this first IITRI report were initially transmitted verbally to this laboratory with acceptance of this facility, and it was requested that biological exposures begin promptly. Upon completion of these exposures, it was observed that the first figure of this IITRI report (Appendix B) was incorrect, and the correct numbered positions (Figure 8) indicated a significant 60 Hz electric field was present in each chamber. Although unable to explain how the magnitude of the field was undetected, IITRI promptly provided revised 60 Hz and 45 Hz field descriptions (Appendices C and D) at locations which allowed the fields to be evaluated on a per-cage basis (Figure 9).

The 45 Hz electric field data for these chambers are summarized in Table 1. Interchamber cross-talk was less than -60 dB; i.e., adjacent chamber electric fields were reduced by at least 10^3 . Use of a guard ring on these chambers reduced the falloff of the vertical chamber field within the animal area from $\pm 10\%$ to $\pm 5\%$. Vertical field strength was not noticeably altered inside an animal cage even with wet or dry litter and full food and water containers. Rats weighing approximately 300 gm in adjacent cages caused fluctuations up to $\pm 2 \frac{1}{2}\%$. Measured vertical electric field strengths within the animal

exposure area ranged from -2% to -12% of the predicted field strength or varied by $\pm 5\%$.

The 60 Hz ambient field data are summarized in Table 2. Electric field strength at the center of the exposure room was 0.5 V/m. The ambient electric field in the exposure chambers was essentially due to the chamber fluorescent lights, and was larger in the upper chambers due to the close proximity of the lower chamber light (Figure 2). In each chamber, maximum ambient field strength occurred at the edge of the exposure area and was minimum in the center. Total magnetic field strength found in the chamber volume and in the room was less than 2 mG and became large only when near the blower motor or the ballast transformers on the wall of the room. Total electric field strength values for each cage were plotted; the average was obtained for each cage position in the upper and lower chamber. These values are summarized in Table 3. In addition, measurements made within the chamber at 180 Hz, a harmonic of 60 Hz, showed the electric field strength to be less than 0.2 V/m and the magnetic field strength to be less than 0.1 mG.

IV. DISCUSSION AND CONCLUSIONS

An irradiation facility has been developed which produces an accurate and uniform exposure of rats and minimally alters the test animals' normal environment. The animal cage was an easily fabricated

nonmetallic design which negligibly perturbed the exposure field and prevented the animals from contacting the exposure plates, a potential shock problem. This cage exceeded the current criteria recommended for housing a rat and provided the means for food and water consumption measurements. A detailed field map at 36 positions within the animal exposure area was obtained for both the exposure field at 45 Hz and the 60 Hz ambient field. The exposure field was further characterized by measuring cross-talk between chambers and field perturbation produced by the cages and test animals. To further characterize the ELF ambient fields, electric and magnetic fields at 180 Hz and magnetic fields at 60 Hz were measured.

The presence of a 60 Hz electric field within the exposure chambers was not unexpected because, at ELF frequencies, every operating electrical appliance and apparatus represents a potential radiation source. For example, ordinary household appliances produce 60 Hz electric field strengths up to several hundred volts per meter (Table 4),¹² and 60 Hz electric field strengths ranging from 0.8 to 13.0 V/m were observed in the center of the rooms in a typical residence (Table 5).¹² Because of the large number of electrical devices in use today, it is essential to have accurate empirical data on the existing ambient field strengths when describing an ELF exposure system.

The following conclusions can be drawn from this work. This facility is a flexible design that will provide for the accurate exposure of six

individual groups of 16 rats each to sinusoidal, ELF, vertical electric fields. Data have been presented to verify the ambient 60 Hz and 180 Hz field strengths within this facility and to accurately specify the 45 Hz exposure fields. Finally, the data presented demonstrate the difficulty of estimating the magnitudes of these field strengths without empirical knowledge.

REFERENCES

1. Sanguine System Final Environmental Impact Statement for Research, Development, Test and Evaluation; Naval Electronics Systems Command; April 1972. PB 199-732-F1 and F2, National Technical Information Service, Springfield, Virginia.
2. Supplement to the Sanguine System Final Environmental Impact Statement for Research, Development, Test and Evaluation; Naval Electronics Systems Command; Department of the Navy, OPNAV-OP941D3, Washington, D.C. (February 1975).
3. Op Cit, Sanguine System Final EIS for RDT&E, Section E-2.
4. Op Cit, Supplement to the Sanguine System Final EIS for RDT&E, Section 6.6.
5. Op Cit, Sanguine System Final EIS for RDT&E, Section 3.3.
6. Kinckerbocker, G. G., et al., Exposure of Mice to a Strong AC Electric Field--An Experimental Study, IEEE Trans. on Power Apparatus and Systems, 86(4), 26-33 (April 1967).
7. Noval, J. J., et al., Extremely Low Frequency Electric Field Induced Changes in Rate of Growth and Brain and Liver Enzymes of Rats. Compilation of Navy Sponsered ELF Biomedical and Ecological Research Reports, VIII, EMR Project Office, NMRDC, Department of the Navy, National Naval Medical Center, Bethesda, MD (To be published).
8. Marino, A. A., et al., Electric Field Effects in Selected Biologic Systems, Ann. N.Y. Acad. Sci., 238, 436-444 (1974).

9. Guide for the Care and Use of Laboratory Animals. National Research Council, DHEW Publication (NIH)73-23, Rev 1972.
10. Feynman, R. P., Leighton, R. B., and Sands, M. The Feynman Lectures on Physics, Vol. 2, pp. 6-11 to 6-13, Addison-Wesley Publ. Co. Inc., New York, N.Y. (1964).
11. Formanec, V. C. An Improved ELF Electric Field Probe, IIT Research Institute Technical Memorandum E6249-2 (March 1974), IIT Research Institute, 10W 35th Street, Chicago, Ill.
12. Valentino, A. R., A Small ELF Electric Field Probe, IIT Research Institute Technical Memorandum E6212-1 (April 1972), IIT Research Institute, 10W 35th Street, Chicago, Ill.

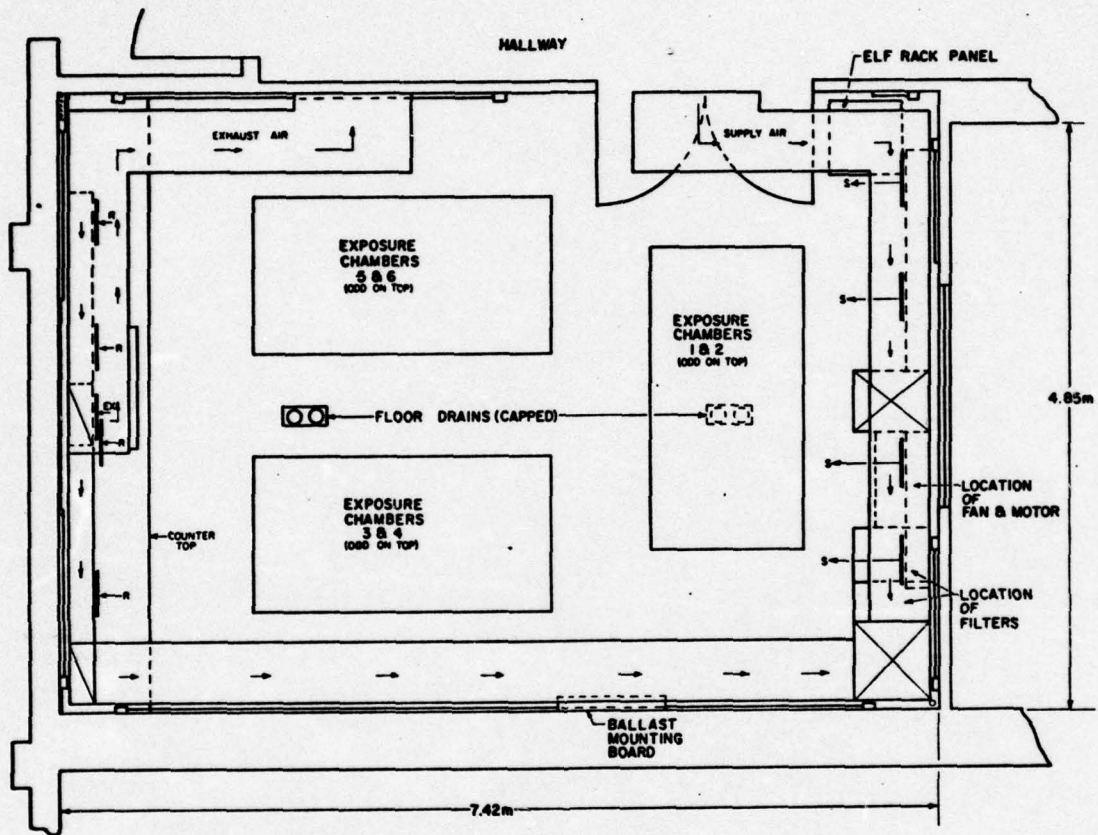

Figure 1. Scale Drawing of the Top View of the Exposure Room

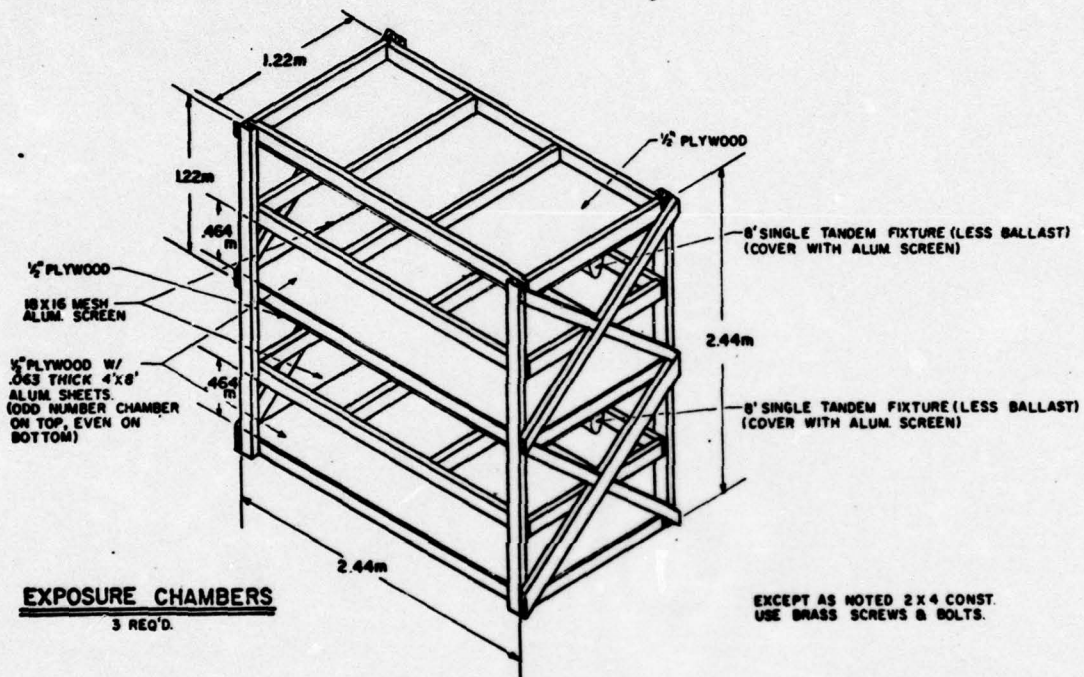

Figure 2. Drawing of Two Exposure Chambers (Contained in a Rack)

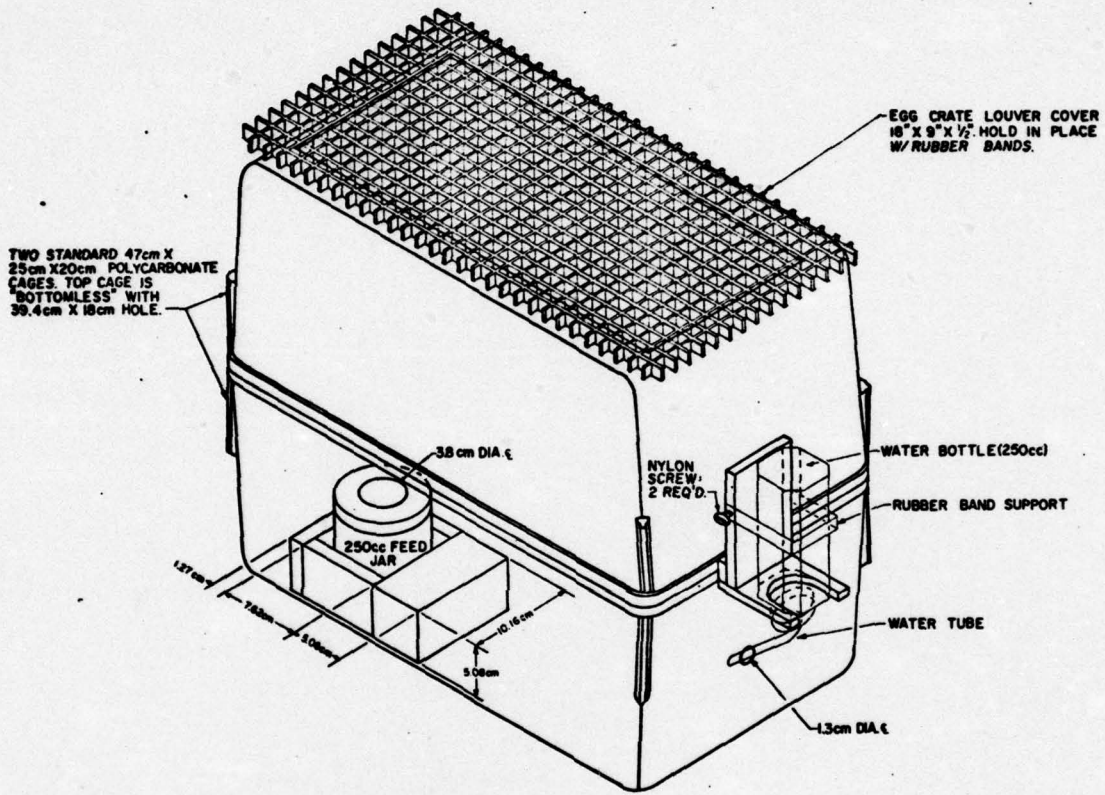

Figure 3. Animal Cage

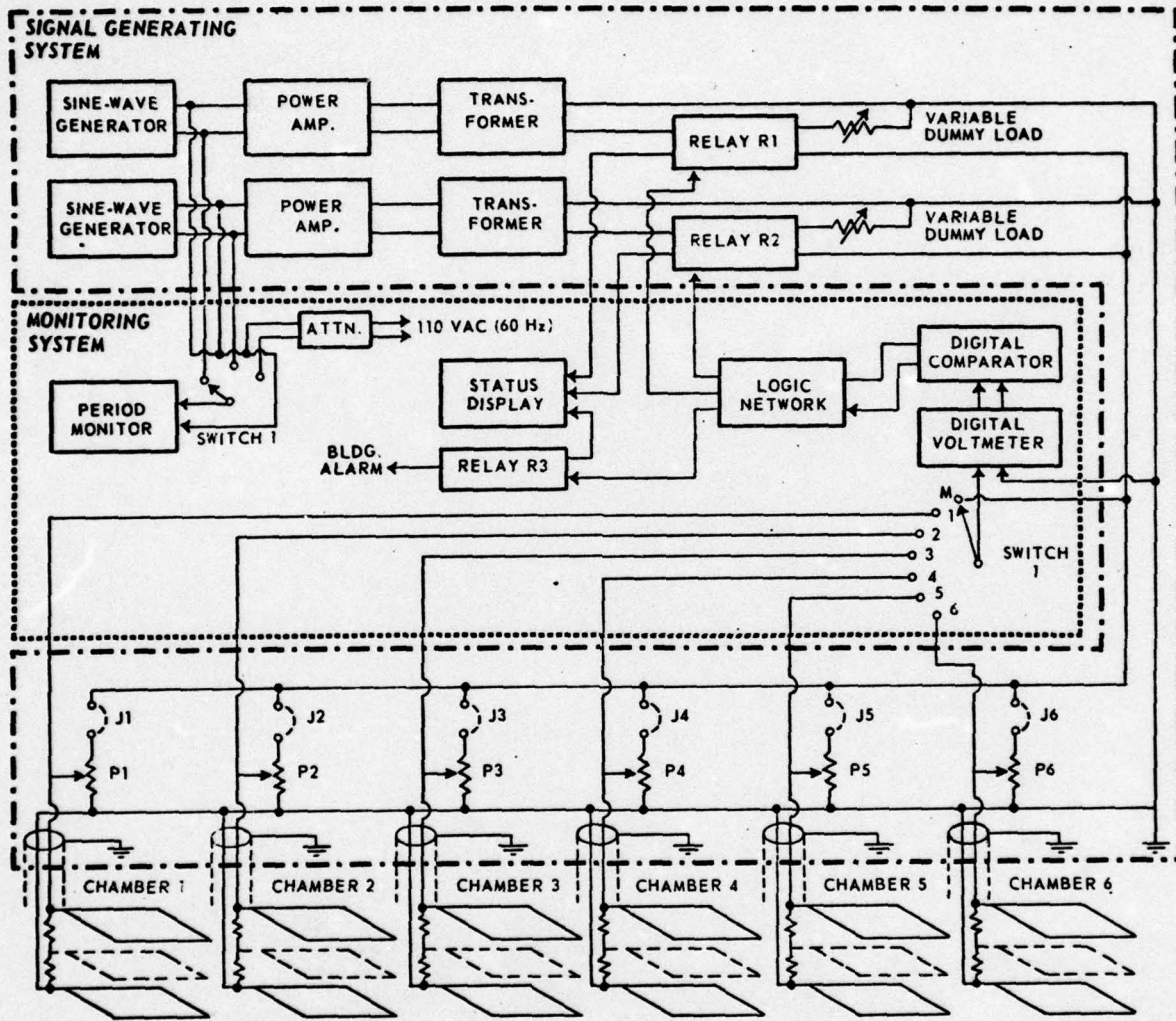

Figure 4. Signal Generating and Monitoring Systems

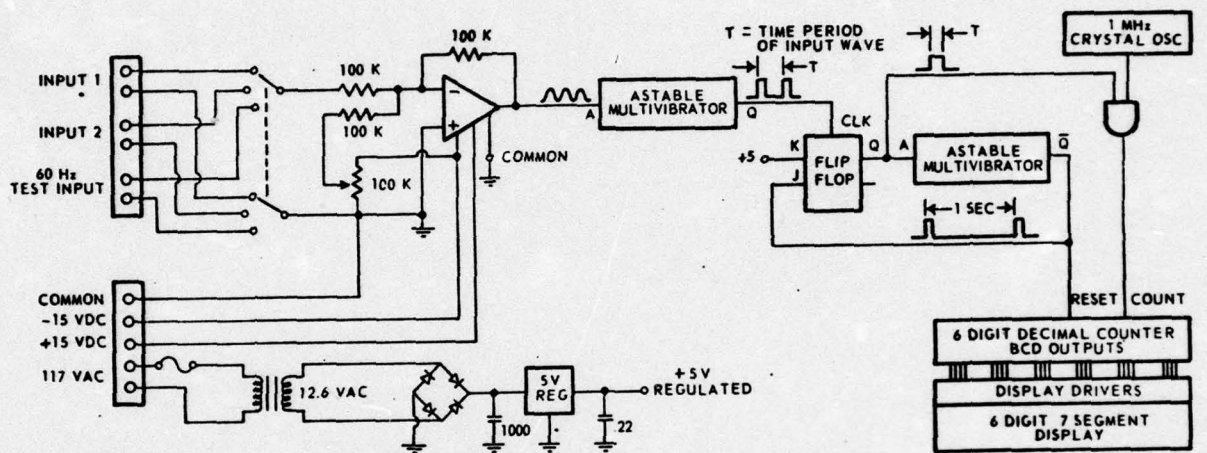

Figure 5. Schematic of Period Meter

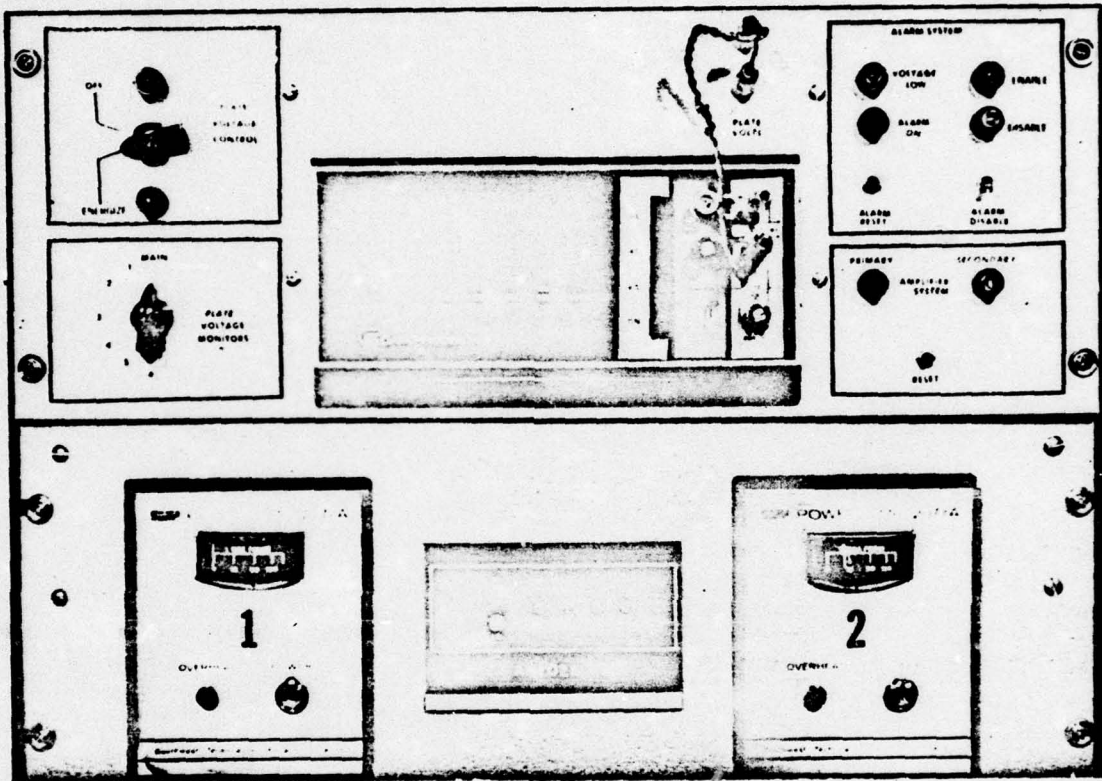

Figure 6. Picture of ELF Status Display Panels

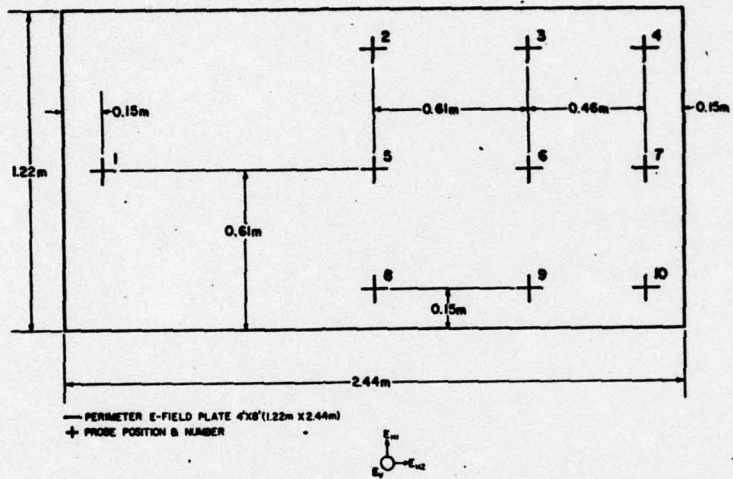

Figure 7. Initial Field Map Locations Within a Chamber

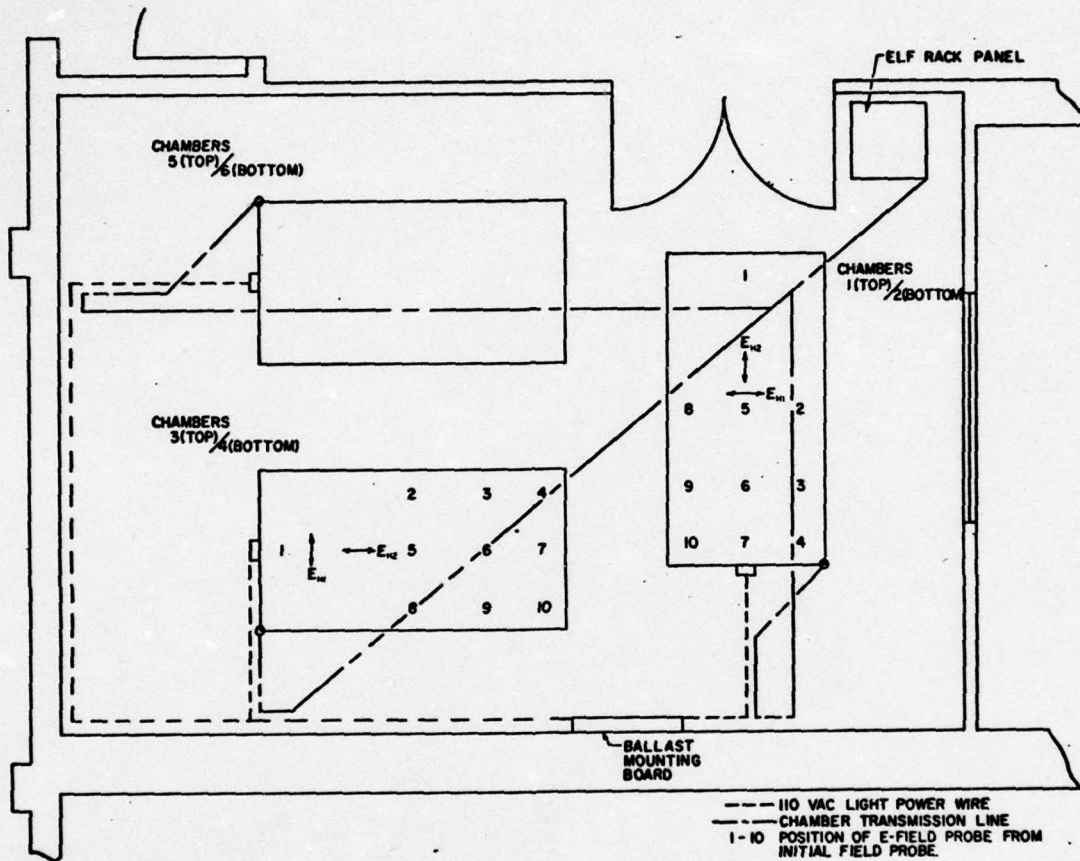

Figure 8. Exposure Chamber Wiring Locations

VERTICAL ELECTRIC FIELD IRRADIATOR
(TOP VIEW)

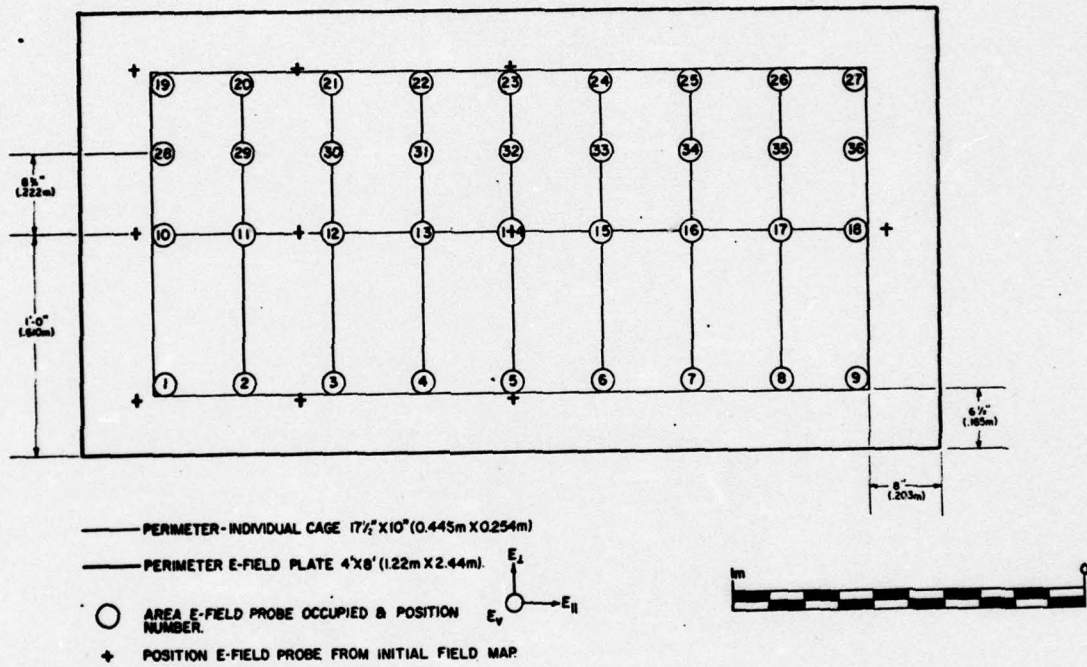

Figure 9. Final Field Map Locations

TABLE 1. Summary of Chamber 45 Hz Vertical Electric Field Characteristics.

Chamber cross-talk	-60 dB
Field variation in animal area without guard circuit	<u>+10%</u>
Field variation in animal area with guard circuit	<u>+5%</u>
Field inside empty cage	not changed
Field inside complete cage (litter (wet or dry) + food + water)	not changed
Field variations caused by 300 g rat in each of three adjacent cages	<u>+2 1/2%</u>
Measured field strength within exposure area compared to predicted field strength*	-2% to -12%

* predicted field strength equal to plate voltage divided by plate separation (V/m) neglecting altered plate charge density due to finite plate size, etc.

TABLE 2. Summary of 60 Hz Ambient Field Strengths with Chamber Lights, Room Heights and Blower Motor On.

A. Electric Field Strength (E) in Center of Room (V/m)*

E vertical = 0.50
 E hor (room width) = 0.13
 E hor (room length) = 0.02
 E total = 0.51

B. Range of Vertical (V) and Total (T) Electric Field Strengths. in Chambers*

	<u>Position #</u>	<u>E_V(V/m)</u>	<u>E_T(V/m)</u>
Upper Chamber			
Max. value	9	5.9	7.0
Min. value	14	0.4	0.4
Lower Chamber			
Max. value	9	1.5	1.7
Min. value	14	0.12	0.14

C. Total Magnetic Field Strength*

In chamber volume <2 mG
 Near ballast transformers on wall 98 mG
 Typical room value (up to 46 cm from blower motor) <2 mG

* all values expressed in RMS units

**TABLE 3. Average Total 60 Hz Field Strength per Cage
(V/m (RMS) per cage)**

<u>Upper Chamber*</u>		<u>Lower Chamber*</u>	
2.7	2.6	.53	.53
1.6	1.5	.32	.32
1.5	1.4	.21	.21
1.3	1.2	.26	.21
1.3	1.1	.26	.21
1.4	1.3	.26	.26
1.7	1.6	.42	.32
3.8	3.5	.84	.63

* values for each cage in the 2x8 cage array used in each chamber.

TABLE 4. 60 Hz Electric Fields in the Vicinity of Electrical Appliances. (The measurements were made at a distance of 30 cm from the appliance.)

(By permission of the author A. R. Valentino. Source: Table 2 of IITRI report #E6212-1.¹²)

<u>APPLIANCE</u>	<u>ELECTRIC FIELD (V/m)</u>
Electric Range	4
Toaster	40
Electric Blanket	250
Iron	60
Broiler	130
Hair Dryer	40
Vaporizer	40
Refrigerator	60
Color TV	30
Stereo	90
Coffee Pot	30
Vacuum Cleaner	16
Clock Radio	15
Hand Mixer	50
Incandescent Light Bulb	2

TABLE 5. 60 Hz Electric Fields at the Center of Various Rooms in a Typical Home.

(By permission of the author A. R. Valentino. Source: Table 2 of IITRI Report #E6212-1.12)

<u>ROOM</u>	<u>ELECTRIC FIELD (V/m)</u>
Living Room	3.3
Kitchen	2.6
Bedroom	7.8
Bedroom	5.5
Bedroom	2.4
Dining Room	0.9
Bathroom	1.5
Bathroom	1.2
Laundry Room	0.8
Hallway	13.0

APPENDIX A. Equipment Specifications

Sine Wave Generator

Manufacturer: TEKTRONIX
Model: SG502
Frequency Range: 5 Hz-500 KHz
Response: .3 dB flatness over entire range
Harmonic Distortion: Less than .1% from 20 Hz to 50 KHz
Hum and Noise: Less than .1% of rated output
Output Voltage: 2.5 rms into 600 Ω
Output Impedance: 600 Ω

Power Amplifier

Manufacturer: Southwest Technical Products Corp.
Model: 207
Power Output: 60 watts RMS
IM Distortion: Less than .1%
Harmonic Distortion: .03%
Input Impedance: 50 K Ω
Sensitivity: 1 volt for full output
Hum and Noise: More than 80 dB below 10 watts
Bandwidth: 1 dB - 1.0 Hz and 250 KHz

Potentiometers (P1 - P6)

Type: 10 turn - to 50 K Ω

Transmission Line

Manufacturer: Belden Co.
Type: 8422 two-conductor shielded

Step-Up Transformers

Manufacturer: TRIAD
Type: SX-202 Hi-Fi stereo shielded output transformer
Frequency Response: ± 2 dB 20-20,000 Hz
Secondary Impedance: 4/8/16 Ω
Primary Impedance: 4500 Ω CT

APPENDIX A. (Cont'd)

Digital Voltmeter

Manufacturer: Data Precision

Model: 2440B1

AC Voltage Accuracy: @40 Hz: $\pm 0.1\%$ reading $\pm 0.02\%$ full scale

AC Range Temperature Coefficient: (30-1 KHz): $(\pm 0.005\% \text{ rdg } \pm 0.002\% \text{ FS})/C^\circ$

DC and Ohm ranges have similar accuracies.

Data Outputs: DTL/TTL compatible

Digital Comparator

Manufacturer: LFE Corporation

Model: 4310

Type: Adjustable high limit

Range: 0 - ± 1999

Input Data: 3 1/2 digits, polarity, overrange

Crystal Oscillator

Manufacturer: Fork Standards, Inc.

Model: AQ-DK1N-1-1M

Frequency: 1 MHz

Accuracy: $\pm 0.005\%$ (-55° to $+85^\circ$ C)

Extracted from IITRI Memorandum of

15 April 1975

SUBJECT: Measurement of ELF Fields at the AFFRI
Sanguine Field Simulators

1. INTRODUCTION

A visit was made to the Armed Forces Radiological Research Institute on 14 March 1975. The purpose of the trip was to map the electric field in the simulators to be used to supply the stress for the Rat Behavior experiments and to measure the ambient electric and magnetic fields in the simulators and simulator room.

2. MEASUREMENTS

The floor plan of the room where the simulators are located and the test positions are shown in Fig. 1. The simulators are stacked vertically in pairs, and consist of a solid aluminum sheet for the lower plate, and metal screen for the upper plate. Fluorescent lights are mounted above the screening with all ballasts mounted remotely on one wall of the room, as shown. Simulators #3 and #4 were equipped with guard rings to reduce field fringing at the edges of the plates.

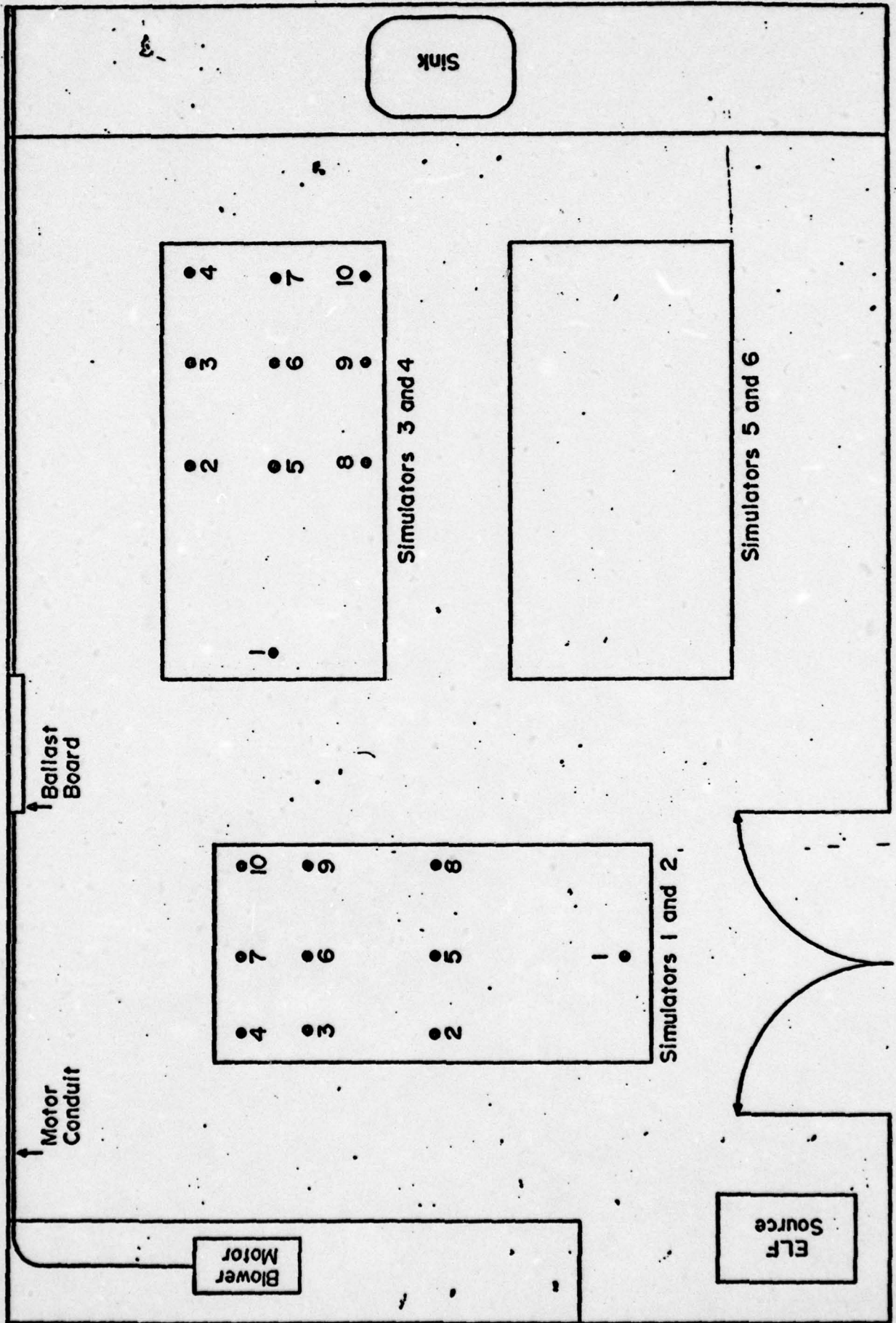

Fig.1 SIMULATOR ROOM LAYOUT

Simulators #1 and #3 were mapped with the IITRI ELF electric field probe to determine the uniformity of the electric field induced between the plates and to determine the effectiveness and necessity of the guard rings.

The electric field measurements at each position were made in the following manner. The vertical component and two perpendicular horizontal components were measured at three different heights above the simulator bottom plate. This procedure was used to insure that any irregularities in the field profile were detected. The data from these measurements for both simulators are presented in Table 1. The magnitude of the vector sum of the three electric field components are also given for each test position to indicate the value of maximum field present.

In addition, measurements were made in simulator #1 to observe the effects on the electric field of placing objects in the simulators. The E field probe was placed in the middle cage of three plastic cages of the type used to house the rats. This located the probe midway between positions 5 and 8 at a height of 4.25 inches. A 45 Hz CW voltage of 10.37 V was applied across the plate separation of 18.25 inches, yielding a nominal field of 22.4 V/m. With the covers off the boxes, a vertical field of 21.2 V/m was measured. Placing the covers on the cages, adding water bottles, and adding wet or dry litter to the cages had no effect on the readings. Placing a rat in each of the end cages caused fluctuations in the electric field of about $\pm .5$ V/m. The greatest changes occurred when the rats stood up.

A series of measurements was made in simulators #1 and #3 to analyze crosstalk between the simulators and the harmonic content of the electric fields. A HP 302 tuned voltmeter was used on the output of the electric field probe to take the data, which are presented in Table 2.

An attempt was made to measure any 15 Hz electric field which might be presented as the beat frequency of the 45 Hz and the 60 Hz fields. The HP 302 was used in conjunction with the electric field probe, but the reading was in the noise level of the voltmeter.

Table 1
SIMULATOR FIELD MAPPING

Simulator #1										No Guard Rings									
h = 4.25"					h = 7.75"					h = 11.75"									
Pos.	E_V	E_{H1}	E_{H2}	$ E $	E_V	E_{H1}	E_{H2}	$ E $	E_V	E_{H1}	E_{H2}	$ E $	E_V	E_{H1}	E_{H2}	$ E $			
1	20.0	0.716	7.03	21.2	20.0	0.345	0.666	20.0	21.7	-	-	-	21.7	-	-	-			
2	19.8	1.28	0.864	19.8	20.0	1.95	0.691	20.1	21.7	-	-	-	21.7	-	-	-			
3	19.8	1.28	0.469	19.8	20.0	1.72	0.913	20.1	21.7	-	-	-	21.7	-	-	-			
4	18.8	4.07	6.66	20.3	19.4	4.44	8.02	21.4	22.7	-	-	-	22.7	-	-	-			
5	21.4	1.06	1.03	21.4	21.4	1.06	0.987	21.4	21.5	-	-	-	21.5	-	-	-			
6	21.4	0.666	0.691	21.4	21.4	0.592	0.740	21.4	21.7	-	-	-	21.7	-	-	-			
7	21.0	1.65	14.8	25.8	19.8	1.43	15.3	25.0	22.5	-	-	-	22.5	-	-	-			
8	19.8	2.24	0.913	19.4	20.0	3.45	0.864	20.3	21.7	-	-	-	21.7	-	-	-			
9	19.8	2.09	0.493	19.9	20.0	2.83	0.888	20.2	21.7	-	-	-	21.7	-	-	-			
10	19.0	1.48	6.04	20.0	18.5	1.72	6.91	19.8	22.5	-	-	-	22.5	-	-	-			
Simulator #3										With Guard Rings									
E - 22.1 V/m*										E - 22.1 V/m*									
Pos.	E_V	E_{H1}	E_{H2}	$ E $	E_V	E_{H1}	E_{H2}	$ E $	E_V	E_{H1}	E_{H2}	$ E $	E_V	E_{H1}	E_{H2}	$ E $			
1	22.5	1.11	11.6	25.3	21.5	-	-	-	22.5	-	-	-	22.5	-	-	-			
2	22.0	1.65	0.691	22.0	21.2	-	-	-	21.9	-	-	-	21.9	-	-	-			
3	22.0	1.48	0.572	22.0	21.2	-	-	-	22.2	-	-	-	22.2	-	-	-			
4	21.2	0.740	2.96	21.5	19.9	-	-	-	21.9	-	-	-	21.9	-	-	-			
5	23.0	1.28	0.913	23.0	22.2	-	-	-	22.7	-	-	-	22.7	-	-	-			
6	23.0	0.888	0.395	23.0	22.2	-	-	-	22.5	-	-	-	22.5	-	-	-			
7	22.5	0.691	7.03	23.6	21.2	-	-	-	22.2	-	-	-	22.2	-	-	-			
8	22.2	2.22	0.469	22.3	21.0	-	-	-	21.7	-	-	-	21.7	-	-	-			
9	22.2	2.71	0.567	22.4	21.0	-	-	-	22.0	-	-	-	22.0	-	-	-			
10	21.5	2.37	3.08	21.8	20.2	-	-	-	21.7	-	-	-	21.7	-	-	-			

* Calculated as: plate voltage/plate separation.

E_V = vertical field E_{H1} and E_{H2} = horizontal field $|E|$ = vector sum of E_V , E_{H1} , & E_{H2}

Table 2
CROSSTALK AND HARMONIC MEASUREMENTS

Conditions	E_v volts/meter		
	45 Hz	60 Hz	180 Hz
In Unit 1, Position #5, $h = 4.25''$ Units 1 & 3 energized, $E = 22.06 \text{ V/m}^*$	22.71	0.317	0.078
In Unit 1, Position #5, $h = 4.25''$ Unit #1 off, #3 energized, $E = 22.06 \text{ V/m}^*$	in noise	0.172	0.079
In Unit 3, between positions 2 & 5 $h - 4.25''$, in plastic cage Unit 3 energized, $E - 22.09 \text{ V/m}^*$	22.46	0.439	0.156
In Unit 3, position 5 $h - 4.25''$, unit not energized	-	Variable 0.145 to 0.218 0.364 peaks	-

*calculated as: plate voltage/plate separation

An IITRI fabricated magnetic field probe and the HP302 tuned voltmeter were used to determine the maximum magnetic field present in the simulators. Measurements were made with the simulators both energized and de-energized. A scan of the simulator room was also made to locate any extraneous sources of magnetic fields. The results are given in Table 3.

3. COMMENTS AND CONCLUSIONS

1. Uniformity of Simulator Fields. From the measurements made in the simulators, the maximum error in the electric field was found to be less than $\pm 20\%$ of the intended field strengths. This occurred in simulator #1 which was not equipped with a guard ring. In simulator #3 which did have a guard ring, the maximum error was less than $\pm 15\%$. However, most of the electric field distortion was confined to the ends of the simulators near the vertical wood supports and cross braces where strong horizontal components of the electric field were present. For this reason, it is recommended that the rat cages be placed no closer than one foot from the ends of simulators and six inches from the sides. This will reduce the field error to less than $\pm 10\%$ in all cases, and to less than $\pm 5\%$ if a guard ring is used.

2. Crosstalk and Harmonics. Crosstalk between simulators was below the limit imposed by the capabilities of the instrumentation, -60 dB (a factor of 1000). Also, 60 Hz levels are at least 34 dB below the simulator fields, and the 180 Hz levels are at least 50 dB down. Some fluctuation in the ambient 60 Hz electric field was seen in simulator #3. This condition was traced to the operation of the ventilating blower motor, whose conduit parallels the simulator. These ambient field levels should pose no problems to the experiments.

3. Magnetic Fields. The highest ambient 60 Hz magnetic field measured in any of the simulators was less than 2.0 mG, which was found in the corner of simulator #3 which is the one nearest to the ballast board (Fig. 1). In general, all 60 Hz magnetic field levels in the units, whether energized or not, were less than 0.5 mG. 45 Hz levels were less than 0.2 mG.

Table 3
MAGNETIC FIELD MEASUREMENTS

Conditions	Frequency (Hz)		
	45	60	180
Measurements in simulator #3 non-energized	0.031 mG	0.37 mG	0.065 mG
Measurements in simulator #1 plate voltage = 10.73 V (E - 24.13 V/m)	0.182 mG	0.463 mG	0.10 mG
Near ballast board	-	98.15 mG	12.5 mG
In simulator #3 nearest ballast board	-	1.68 mG	-

These values are representative of ambient magnetic field levels in a typical residence. Within the simulator room, the maximum magnetic field measured was 98 mG at the fluorescent light ballast board.

4. Mutual Effects of Subjects in the Simulator. The measurements made with the electric field probe inside the plastic rat cages indicate that little, if any, distorting of the electric field is caused by the life support systems for the rats. Although some variations in the electric field occurred in one cage as a result of rat movement in adjoining cages, these fluctuations were found to be less than $\pm 2.5\%$ of the applied field.

5. Attempted Measurements of 15 Hz Fields. A calibration of the electric field probe and the HP 302 tuned voltmeter combination conducted at the IITRI laboratory has shown that the maximum sensitivity of these instruments at 15 Hz is 10 mV/m. As the 15 Hz measurements made at AFRRRI were in the noise levels, it is concluded that any 15 Hz fields present in the ELF field simulators were less than 10 mV/m.

In conclusion, it is felt that the present simulators provide a uniform ELF electric field exposure for the test subjects in the experiment, provided the cages are kept at least one foot from the ends, six inches from the sides of the simulators, and that guard rings are included in the simulators that do not have them. The rationale for this conclusion and recommendations are: 1) these conditions limit the variation of the field across the simulator to nearly the same levels as the variation of the field across the simulator to nearly the same levels as the variations caused by rats moving within the simulator, and 2) this still allows a reasonable area within the simulator for experimentation. Finally, the ambient 60 Hz electric and magnetic fields measured in the simulator are typical of those found in office and residence environments and should not pose a problem to this experiment.

Appendix C

Extracted from IITRI Memorandum, undated

**SUBJECT: Measurement of ELF Electromagnetic Fields
at the AFRI ELF Field Simulators**

1. INTRODUCTION

A visit was made to the Armed Forces Radiobiology Research Institute on 13-14 September 1976. The purpose of the trip was to map the 60 Hz ambient electric fields present in the parallel plate vertical electric field simulator used in previous rat experiments, and to do a preliminary mapping and checkout of the combined electric and magnetic field simulator to be used in forthcoming experiments.

2. EQUIPMENT

The sensors used for measuring the high impedance electric fields and the magnetic fields were the IITRI-fabricated high impedance electric field probe* and magnetic field probe. The magnetic field probe is simply a many turned coil of wire with a ferrite core and appropriate terminating resistor. Conversion tables are used to convert the output voltage readings of the probes to equivalent electric and magnetic field levels. The meter used

* V. C. Formanek, "An Improved ELF Electric Field Probe,"
IIT Research Institute Technical Memorandum E6249-2 (March 1974).

in conjunction with the probes was the Hewlett-Packard 3581A signal wave analyzer. The HP3581A functions as a frequency selective voltmeter, and was factory modified for a 1 Hz bandwidth and battery operation. For these measurements, the HP3581A was used with a 3 Hz bandwidth and was line operated due to battery failure. The electric field probe was zeroed and calibrated at regular intervals during the measurements and remained constant to within about two percent.

3. VERTICAL ELECTRIC FIELD SIMULATOR

3.1 Physical Layout

A set of 60 Hz ambient electric field data was taken to supplement field mapping data which was obtained on 14 March 1975. In order to make these measurements after the completion of the experiment, AFRRRI personnel reconstructed one of the vertical electric field simulators used in the initial setup. This simulator was positioned in the approximate location of chambers 3 and 4 in the same ELF exposure room used in the experiment. Figure 1 presents the location of the points where data were taken in test chambers 3 and 4. Figure 2 gives the layout of ELF exposure Room No. 1440, and the positioning of the test chambers. The temporary routing of the 110 VAC wiring and ballast board for the chamber fluorescent lights is also shown. It was determined at the time of the simulator reconstruction that the fluorescent light fixtures for the chambers were not grounded during the period of the experiment.

3.2 60 Hz Ambient Electric Field Measurements

Three perpendicular components of the high impedance 60 Hz ambient electric field were measured at each of the 36 test points shown in Figure 1 in the orientation described. The measurements were made at a height of approximately 3.5 inches above the lower plate of the simulator. The data from these measurements for chambers 3 and 4 are presented in Tables 1 and 2, respectively. The magnitude of the vector sum of the three electric field components, computed as the square root of the sum of the squares of the three components, is also given for each test position to indicate the maximum value of 60 Hz ambient electric field present.

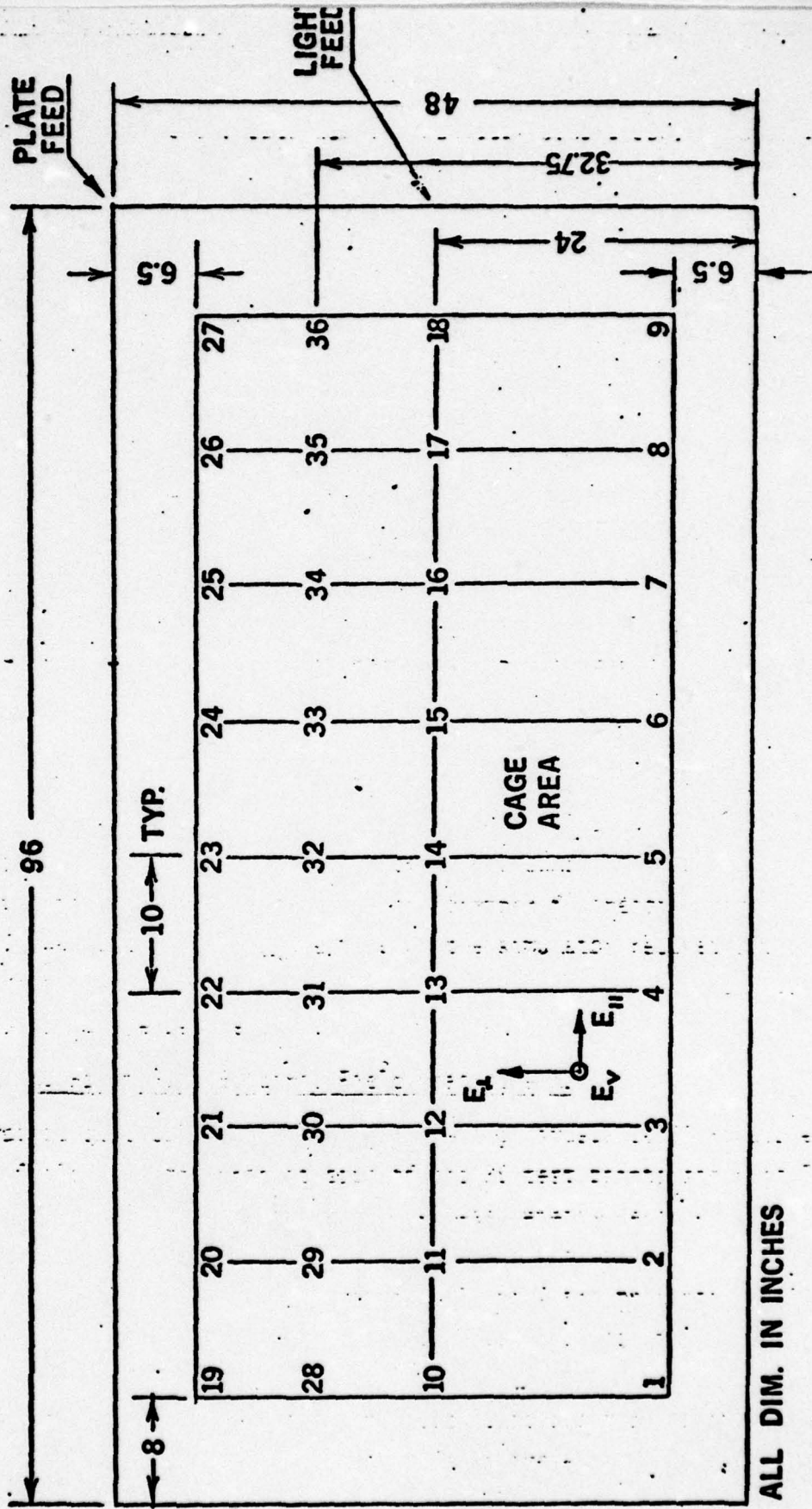

ALL DIM. IN INCHES

FIG. 1 ELF ELECTRIC FIELD SIMULATOR: RM. 1440

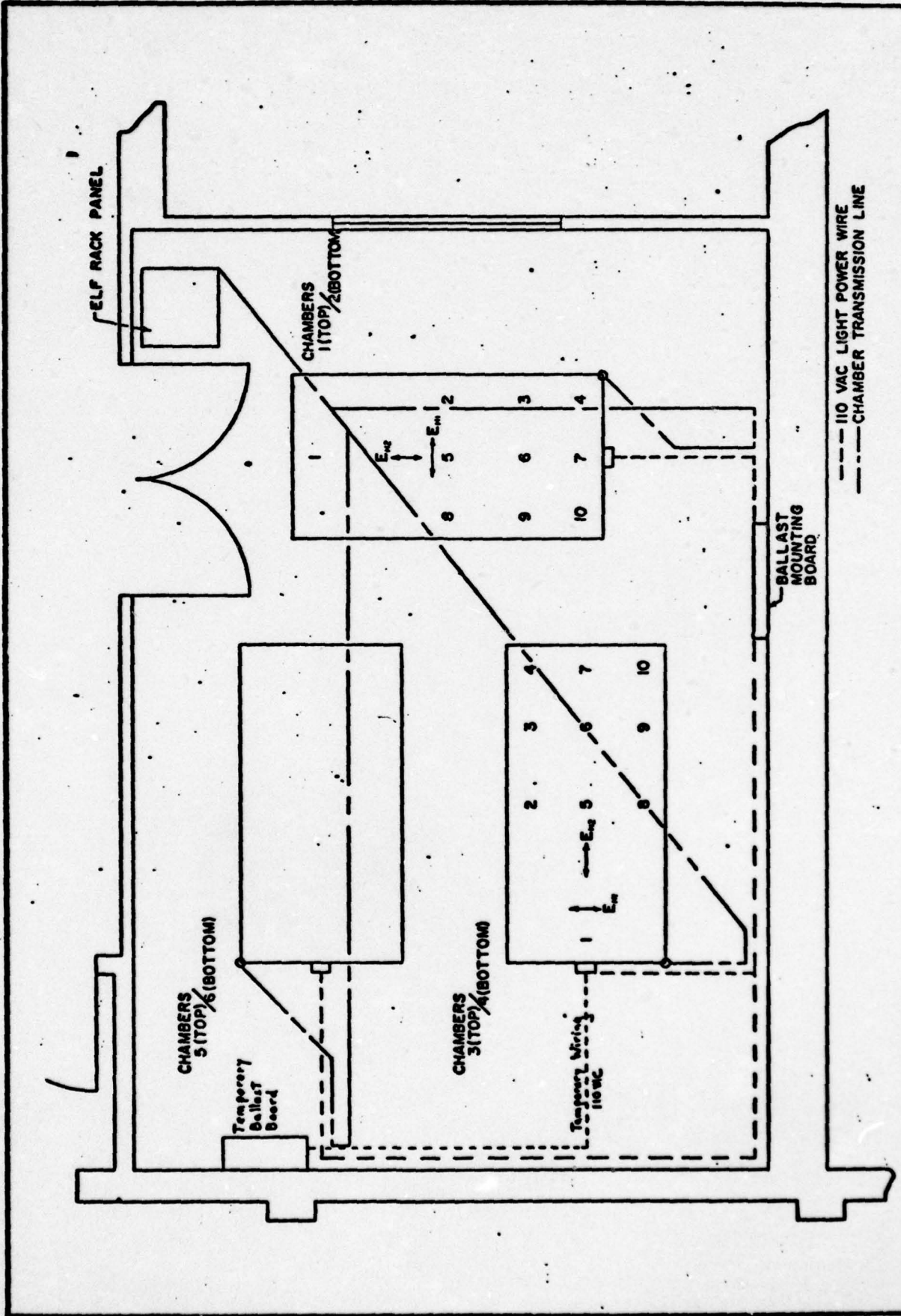

ARMED FORCES RADIOBIOLOGY RESEARCH INSTITUTE FACILITIES & ENGINEERING DIVISION	FIGURE 2 RM. 1440: ELF EXPOSURE ROOM		DRAWN BY: BRUCE IMBACH	DATE: 9/31/78	SHEET: 13
			APPROVED:	SCALE: O127m = 3048m	OF: 13

Table 1
60 Hz AMBIENT ELECTRIC FIELD LEVELS IN ELECTRIC FIELD SIMULATOR #3 (TOP)

Position	E_{vert} V/m	$E_{ }$ V/m	E_{\perp} V/m	$ E $ V/m	Position	E_{vert} V/m	$E_{ }$ V/m	E_{\perp} V/m	$ E $ V/m
*					*				
1	4.06	1.16	2.47	4.89	19	4.18	1.54	2.26	4.99
2	2.96	0.055	2.49	3.87	20	2.86	0.319	2.31	3.68
3	2.69	0.330	2.58	3.76	21	2.47	0.132	2.31	3.39
4	2.74	0.264	2.47	3.70	22	2.42	0.050	2.31	3.34
5	2.71	0.264	2.04	3.40	23	2.31	0.055	2.09	3.11
6	2.86	0.418	2.26	3.67	24	2.31	0.110	2.19	3.19
7	3.05	0.594	2.26	3.84	25	2.36	0.104	2.14	3.20
8	3.85	0.923	2.14	4.50	26	2.58	0.274	1.81	3.18
9	5.94	3.08	1.92	6.96	27	4.67	1.59	0.659	4.98
*					*				
10	2.33	1.59	0.281	2.82	28	2.81	0.582	0.176	2.87
11	0.901	0.319	0.104	0.961	29	1.21	0.517	0.291	1.35
12	0.473	0.028	0.074	0.479	30	0.781	0.121	0.373	0.873
13	0.428	0.017	0.058	0.433	31	0.704	0.050	0.341	0.784
14	0.418	0.021	0.060	0.423	32	0.759	0.067	0.373	0.848
15	0.428	0.036	0.071	0.436	33	0.769	0.019	0.385	0.860
16	0.550	0.132	0.082	0.571	34	0.901	0.069	0.352	0.969
17	1.37	0.736	0.121	1.56	35	1.49	0.538	0.176	1.58
18	5.82	3.30	3.63	7.62	36	3.73	2.64	0.791	4.64

* Indicates a probe calibration point; measurements made with room and simulator lights on, simulator off.

Table 2

60 HZ AMBIENT ELECTRIC FIELD LEVELS IN ELECTRIC FIELD SIMULATOR #4 (BOTTOM)

Position	E_{vert} V/m	$E_{ }$ V/m	E_{\perp} V/m	$ E $ V/m	Position	E_{vert} V/m	$E_{ }$ V/m	E_{\perp} V/m	$ E $ V/m
*					*				
1	0.769	0.121	0.258	0.821	19	0.791	0.170	0.104	0.815
2	0.572	0.014	0.302	0.647	20	0.550	0.044	0.165	0.575
3	0.572	0.017	0.341	0.666	21	0.483	< 0.011	0.253	0.545
4	0.572	0.026	0.330	0.660	22	0.483	< 0.011	0.242	0.540
5	0.594	0.037	0.341	0.686	23	0.495	0.025	0.226	0.544
6	0.637	0.066	0.341	0.726	24	0.495	0.033	0.231	0.546
7	0.692	0.060	0.373	0.789	25	0.462	0.011	0.242	0.521
8	0.880	0.154	0.374	0.967	26	0.517	0.069	0.198	0.557
9	1.53	0.571	0.296	1.66	27	0.769	0.253	0.033	0.810
*					*				
10	0.540	0.319	0.017	0.628	28	0.637	0.274	0.044	0.695
11	0.231	0.088	< 0.011	0.247	29	0.264	0.088	0.071	0.287
12	0.132	0.017	< 0.011	0.133	30	0.176	0.022	0.079	0.194
13	0.121	< 0.011	< 0.011	0.122	31	0.176	0.014	0.079	0.194
14	0.121	< 0.011	< 0.011	0.122	32	0.176	0.017	0.061	0.188
15	0.127	< 0.011	< 0.011	0.128	33	0.187	< 0.011	0.066	0.198
16	0.154	0.012	0.017	0.155	34	0.204	0.017	0.071	0.216
17	0.296	0.121	0.019	0.321	35	0.330	0.115	0.059	0.354
18	0.967	0.538	0.165	1.12	36	0.901	0.473	0.011	1.02
					*				
			center of room,		blowers off	0.462	0.022	0.121	0.478
			center of room,		blowers on	0.495	0.022	0.132	0.512

* Indicates a probe calibration point; measurements made with room and simulator lights on, simulator off.

The 60 Hz ambient measurements were taken with both the fluorescent room lights and the fluorescent chamber lights on. It was determined by observation of the 60 Hz electric field level with various combinations of room and chamber lights switched off that the 60 Hz ambient field levels within the simulators were due primarily to the chamber fluorescent lights, and not the room lights. The simulators were not energized at the time of the measurements, but were connected to the same output circuitry as when driven. Both chambers were equipped with guard rings.

4. ELECTRIC AND MAGNETIC FIELD SIMULATOR

4.1 Physical Layout

Figures 3 and 4 are drawings of the combined electric and magnetic field simulator, and of ELF exposure room 1438 in which the simulator was located, respectively. The magnetic field simulator consists of five coils of about 5-ft diameter and 2½-ft spacing on a common axis. The electric field is produced by three parallel vertical plates which run the length of the simulator. Two rows of twelve rat cages are placed between the plates, as shown. The bottom of the cages consists of metal rods connected by appropriate resistors to produce an electric voltage gradient between the bars equal to the electric field between the parallel plates. The outer plates were grounded while the center plate was driven; the cages were connected between the plates. The five coils were driven in parallel.

The simulator was positioned approximately as shown in Figure 4, which also gives the location of the drive circuitry and feed lines. Room 1440, which contained the vertical electric field simulator, is located to the right of Room 1438 and is connected to it by the double doors. Both rooms will be used in the new experiment, with the control simulators in one room and the test simulators in the other.

At the time of these preliminary measurements, only one of four simulators was completed, and it contained only one row of cages.

4.2 72 Hz Electric Field Measurements

Table 3 presents three sets of 72 Hz electric field data taken in cages U-Z. These measurements were taken with the plates energized to

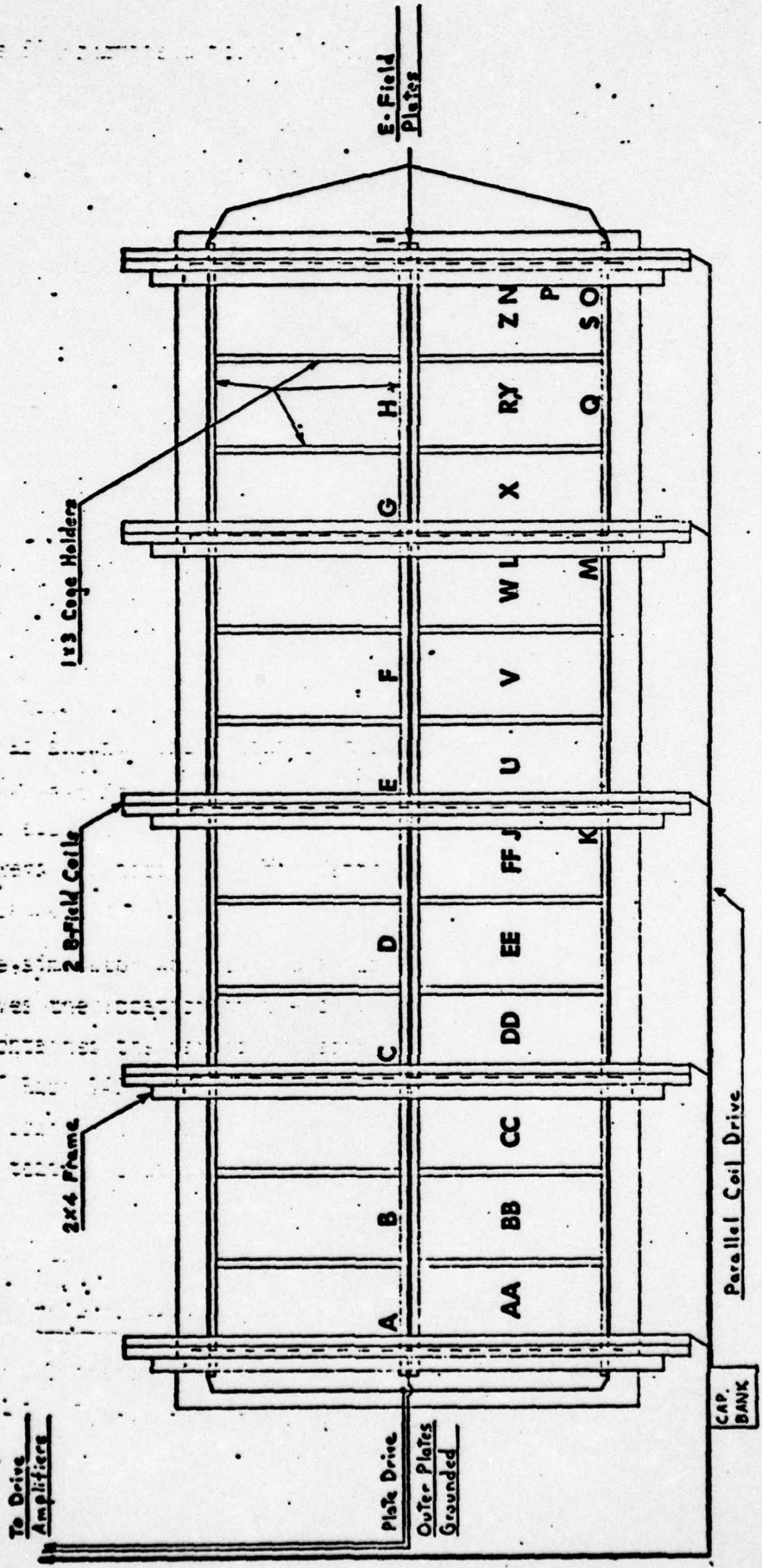

Fig. 3 ELF Electromagnetic Field Simulator and Cage Holder: Rm. 1438

COPY AVAILABLE TO DDC. DOES NOT PERMIT FULLY LEGIBLE PRODUCTION

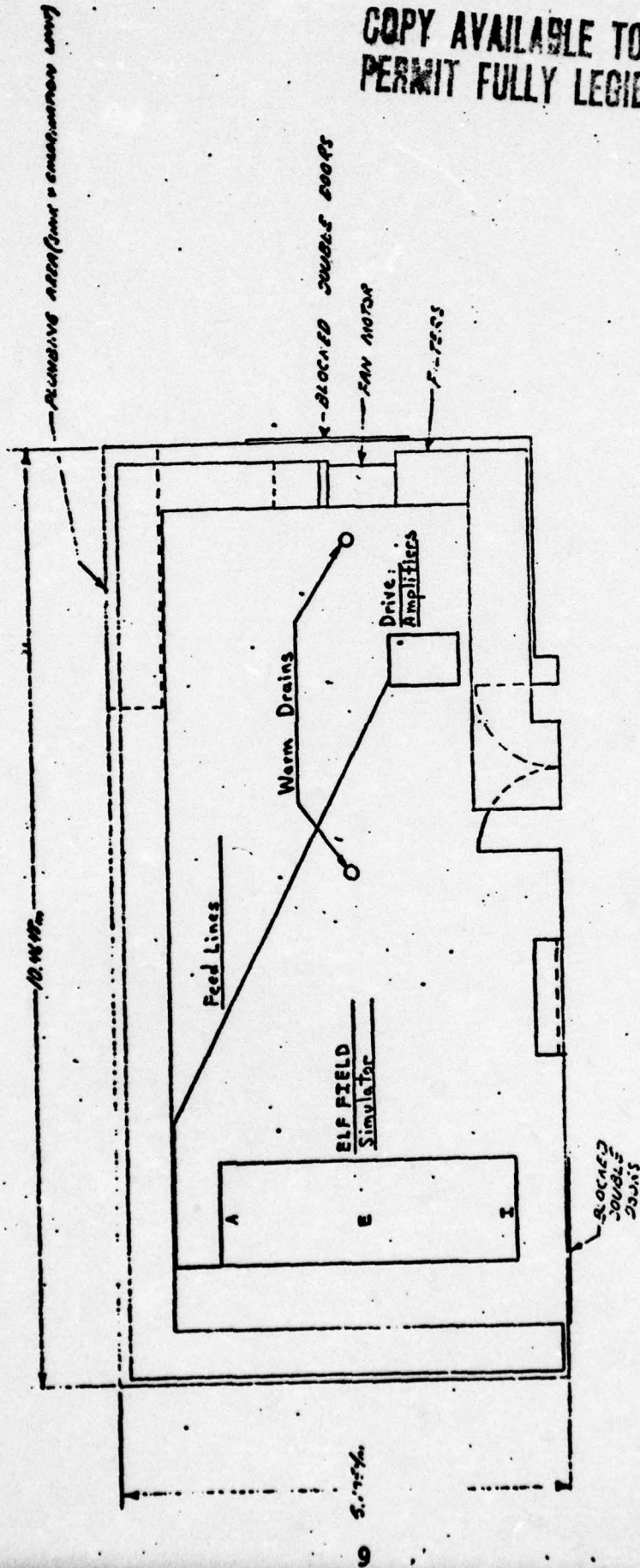

Fig. 4 ELF Exposure Room 1438

Table 3
 COMPARISON OF ELECTRIC FIELD LEVELS WITH COILS DRIVEN/OFF AND
 COIL SHIELD GROUNDED/UNGROUNDED

Coil Shield Condition	Position	E_{vert} V/m	$E_{ }$ V/m	E_{\perp} V/m	$ E $ V/m	Comments
	U	1.47	0.370	9.13	9.26	Coil Voltage = 0.0 V Plate Voltage = 5.6 V Plate Spacing = 0.56 m
	V	1.09	0.630	9.03	9.11	
	W	1.31	0.163	9.03	9.12	
	X	1.31	0.434	9.08	9.18	
	Y	1.41	1.57	9.13	9.37	
	Z	1.03	0.706	9.03	9.11	
ungrounded	U	15.2	2.60	7.61	17.2	Coil Voltage = 25.01 V Plate Voltage = 5.61 V Plate Spacing = 0.56 m
grounded	U	0.848	1.90	8.70	8.94	
ungrounded	W	13.6	1.36	7.94	15.8	
grounded	H	0.109	0.511	9.03	9.04	
ungrounded	Y	10.9	0.522	7.94	13.5	
grounded	Y	0.434	0.326	8.91	8.93	
ungrounded	U	29.9	5.43	10.1	32.1	Coil Voltage = 50.4 V Plate Voltage = 5.59 V Plate Spacing = 0.56 m
grounded	U	3.10	4.13	8.70	10.1	
ungrounded	W	26.7	2.34	9.78	28.5	
grounded	W	0.446	0.228	8.70	8.71	
ungrounded	Y	22.8	1.09	8.37	24.3	
grounded	Y	0.576	0.479	8.70	8.73	

NOTE: Freq. = 72 Hz, Room Lights ON.

about 5.6 volts. With the plate spacing used, the expected electric field would be 10 volts/meter. The coils were off, and driven at about 2.5 and 5.0 gauss, respectively. At this time only six cages (U-Z) were in the simulator. These data suggest three things:

- 1) the main field between the plates (E_{\perp}) was fairly uniform,
- 2) with the coils driven, significant vertical and parallel components of the electric field were present, primarily due to field fringing between the E field plates and the driven coils, and
- 3) more fringing was taking place near the center of the simulator, where the missing six cages were causing a discontinuity in the field.

To counteract (2), temporary shielding for the coils was erected using aluminum foil and/or screen. With the temporary shields grounded to the outer electric field plates, significant reduction of the fringing fields was realized. As given in those rows labeled "grounded" in Table 3, this reduction varied from one to two orders of magnitude.

With the remaining six cages in the row in place and electrically connected, and the coils still shielded, a more complete set of electric field data was taken. This is presented in Table 4. Here it can be seen that the main component of the electric field (the perpendicular component) is quite uniform ($< \pm 2\%$ variation) although less than the expected magnitude by about ten percent. The parallel and vertical components of the field are less than ten percent of the perpendicular component, except in the end cages where these components are as high as 25 percent of the main field.

4.3 72 Hz Magnetic Field Measurements

A series of 72 Hz magnetic field measurements was made at positions A through S in the simulator (see Table 5 and Figure 3). All three components of the magnetic field were measured only at position S, which was considered to be a "worst case" reading. All other data were taken along the main axis of the simulator, termed the parallel component. Variation of the magnetic field over most of the simulator was less than 14 percent. The field at position "O" in the extreme corner was about 25 percent higher than in the center. At position S, also near the corner, the perpendicular and vertical components of the magnetic field were less than 12 percent of the parallel field.

Table 4
72 Hz ELECTRIC FIELD UNIFORMITY MAPPING

Position	E_{vert} V/m	$E_{ }$ V/m	E_{\perp} V/m	$ E $ V/m	
AA	0.706	2.12	8.70	8.98	
BB	0.827	1.85	8.91	9.13	
CC	0.522	0.684	8.91	8.95	
DD	0.543	0.956	8.70	8.77	
EE	0.413	0.467	8.80	8.82	
FF	0.815	0.751	8.75	8.81	
U	0.565	0.348	8.80	8.82	
V	0.542	0.174	8.86	8.89	
W	0.542	0.870	8.91	8.97	
X	0.630	0.272	8.86	8.88	
Y	0.653	0.542	8.80	8.85	
Z	0.489	1.74	8.70	8.89	

NOTES: Coil Voltage = 25.06 V Plate Voltage = 5.60 V
 Plate Spacing = 0.56 m Room lights ON

Table 5
72 Hz MAGNETIC FIELD UNIFORMITY MAPPING

Position	$B_{ }$ gauss	Position	$B_{ }$ gauss	Position	$B_{ }$ gauss
A	2.37	H	2.51	O	3.14
B	2.46	I	2.46	P	2.71
C	2.51	J	2.56	Q	2.29
D	2.46	K	2.73	R	2.46
E	2.51	L	2.54	S	2.80
F	2.46	M	2.66	S, B	0.28
G	2.51	N	2.54	S, B _{vert}	0.21

NOTES: Coil Voltage \approx 25.0 V Room lights ON

A series of magnetic field measurements was made along a line which was perpendicular to, and which bisected, the main axis of the simulator in order to determine the rate of fall-off of the magnetic field. These data, normalized to a one-gauss level and plotted as a function of distance from the main axis of the simulator, are presented in Figure 5. Note that the field is down by 40 dB at a distance of about 15 feet from the simulator axis, and appears to level off at about -54 dB.

4.4 60 Hz Ambient Measurements

60 Hz ambient magnetic and electric fields were measured at numerous points in rooms 1438 and 1440. These data are presented in Tables 6 and 7, respectively. The measurements were made with the electric and magnetic field simulator de-energized, and with the lights in both rooms on. Blowers used for the rooms' life support system were on as noted for the magnetic field readings. The blowers were not on for the electric field measurements in Room 1438, as the blowers were some distance from the measurement points.

Measurements were made in a rat cage in a storage rack, and in the area next to the rack. This was done to gain some insight into the field levels to which a rat might be exposed prior to an experiment. The field levels outside the cage were fairly high due to the proximity of a fluorescent hall light, but the cage and rack provided better than 40 dB of shielding.

5. DISCUSSION AND COMMENTS

5.1 Vertical Electric Field Simulator

In general, the 60 Hz ambient electric fields were higher along the sides of the simulator than near the center, and were highest at the ends of the simulator. The lower chamber, No. 4, had considerably lower fields than the upper chamber, No. 3, with the electric fields at almost all points less than 1 V/m. The upper chamber had fields near the end cages of up to 7.6 V/m, and along the sides of 3-4 V/m. These levels are slightly higher than would be desired, but are well within the range of the 60 Hz ambient electric field levels commonly found in an office or private dwelling. For example, the field 30 centimeters from an incandescent light is about 2 V/m,

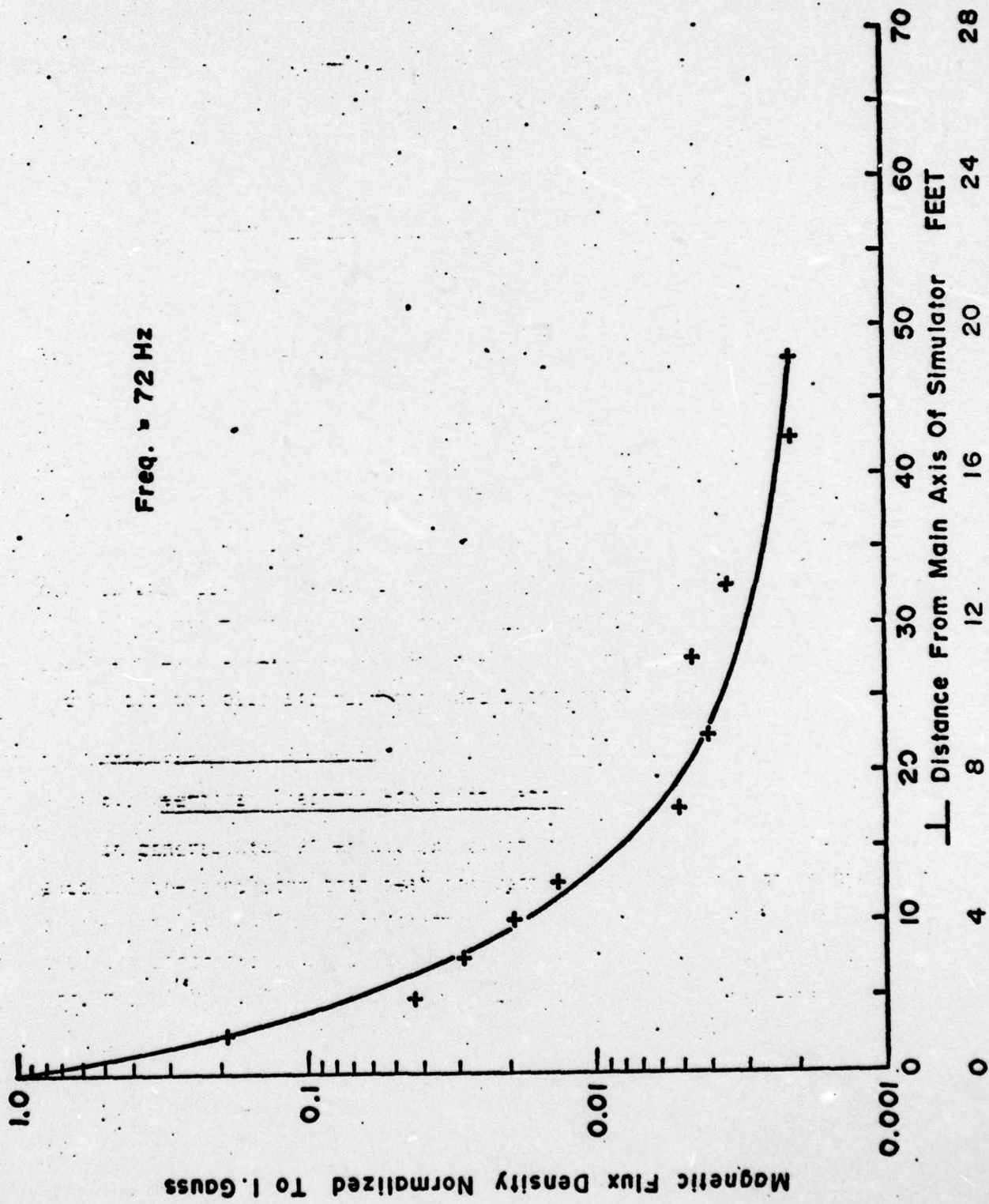

MAGNETIC FLUX DENSITY AS A FUNCTION OF \perp DISTANCE FROM
 Number Of Radii From Main Axis Of Simulator

Table 6
60 Hz AMBIENT MAGNETIC FIELD LEVELS

Location, Conditions (coils OFF for all measurements)	$B_{ }$ (gauss)	B_{\perp} (gauss)	B_{vert} (gauss)	$ B $ (gauss)
A, in simulator blowers ON	0.00160	0.00054	0.00025	0.00170
E, in simulator blowers ON	0.00154	0.00096	0.00065	0.00193
I, in simulator blowers ON	0.00177	0.00125	0.00106	0.00241
Room 1438, 3' high, blowers ON over warm drain, room center	0.00135	0.00052	0.00083	0.00167
Room 1438, 3' high, blowers ON over warm drain, near blowers	0.00096	0.00106	0.00081	0.00164
Room 1440, 3' high, blowers on over brass plate near blowers	0.00115	0.00092	0.00144	0.00206
Room 1440, 3' high, blowers ON middle of room (16 radii)	0.00096	0.00077	0.00115	0.00168
Room 1440, 3' high, blowers OFF 19 radii (47.5') from simulator	0.00010	0.00038	0.00015	0.00042
Room 1440, 3' high, blowers ON 19 radii (425') from simulator	0.00087	0.00096	0.00014	0.00104
Maximum reading 18" from blower motor, Room 1440	--	--	--	< 0.002
Maximum reading 6" from blower motor, feed conduit, Room 1440	--	--	--	< 0.0002

NOTE: Room lights ON

Table 7
60 Hz AMBIENT ELECTRIC FIELD LEVELS

Location	E_{vert} V/m	$E_{ }$ V/m	E_{\perp} V/m	$ E $ V/m
AA	0.077	0.014	< 0.011	0.079
FF	0.062	0.011	< 0.011	0.064
Z	0.122	< 0.011	0.018	0.124
Middle of Room 1438	0.659	0.066	0.055	0.664
In rat cage in rack	0.027	0.011	0.027	0.040
In hall next to rack (near fluorescent light)	3.30	2.74	13.2	13.8
Center Room 1440, blowers OFF	0.462	0.022	0.121	0.478
Center Room 1440, blowers ON	0.495	0.022	0.132	0.512

NOTE: Room lights ON

30 centimeters from a clock radio about 15 V/m, and 30 centimeters from an electric blanket about 250 V/m.*

It should be noted that the end test positions, which mark the extremities of the end cages, are within an area that was recommended to be avoided because of field nonuniformities measured in the initial simulator mapping in 1975.**

5.2 Combined ELF Electric and Magnetic Field Simulator

The magnetic field produced by the simulator appeared to be fairly uniform, with less than 14 percent variation of the parallel (main) field over most of the test area. Only in the extreme corners on the ends of the simulator was a larger deviation noted; about 25 percent greater field level than at the center of the simulator. This should not pose a problem, however, as only a small area is involved. The perpendicular and vertical components of the magnetic field, measured at a point where they would be expected to be greatest, were found to be less than 12 percent of the parallel magnetic field on the main axis. This is typical of this type of magnetic field simulator, which is basically a multiple Helmholtz coil configuration.

The electric field, as shown by Table 3, is not as well behaved as the magnetic field. A grounded shield for the magnetic field coils was found to be necessary in order to significantly reduce electric field fringing between the electric field plates and the driven coils. Both solid and screen shields were found to be effective. With the coils shielded, the main (perpendicular) component of the electric field was uniform to within ± 2 percent, but the field level was about 10 percent lower than was expected for the

* Naval Electronic Systems Command, Sanguine System Final Environmental Impact Statement, p. 74 (April 1972).

** "Measurement of ELF Fields at the AFRRRI Sanguine Field Simulators," memo from IITRI to PME 117-214, 3 April 1975.

applied plate voltage and the plate separation used. This is probably due to the fact that the height of the electric field plates (about 16 inches) is somewhat less than the plate separation (about 22 inches). The desired height to spacing ratio is at least 1.5. Four possible solutions to this problem are:

- 1) Increase the height of the drive plates as much as is feasible to reduce fringing.
- 2) Use one or more "guard rings" at the top of the plates to force the electric field to be more uniform. Note that these should be open rings to avoid coupling to the magnetic field.
- 3) Increase the drive voltage to the plates to increase the electric field in the air *between the plates*. This must be accompanied by an increase in the series resistors to the cages to maintain the proper voltage gradient on the cage floor bars.
- 4) Replace the 1 x 3 wood cage supports with a less conductive material such as plexiglass or fiberglass. This should also result in some reduction and/or more uniformity in the parallel and vertical electric fields.

Another distortion in the electric field is reflected in the high values of parallel field seen near the ends of the simulator. This is also probably related to being near the edges of the plates (in this case, the ends rather than the top). A possible solution to this problem would be to put guard bars between the plates at the ends of the simulator in much the same manner as was suggested for the top of the plates.

The 60 Hz ambient electric and magnetic fields measured in ELF exposure rooms 1440 and 1438 are summarized in Tables 6 and 7. It can be seen that the ambient 60 Hz magnetic field is generally below 0.0025 gauss, while the electric field level is generally below 1 V/m. The electric field levels in the combined simulator were less than 0.1 V/m. These levels should not pose a problem to the future experiments.

Appendix D

NSM

Extracted from IITRI Memorandum, 15 October 1976

**COPY AVAILABLE TO DDC DOES NOT
PERMIT FULLY LEGIBLE PRODUCTION**

**SUBJECT: Measurement of ELF Electromagnetic Fields
at the AFRRRI ELF Field Simulators**

1. INTRODUCTION

A visit was made to the Armed Forces Radiobiology Research Institute on 6 October 1976. The purpose of the trip was to remap the 45 Hz electric fields generated by the parallel plate vertical electric field simulator used in previous rat experiments, and to determine the effectiveness of modifications made to the combined electric and magnetic field simulator to be used in forthcoming experiments. Only 45 Hz vertical electric field data are presented at this time, to expedite receipt of this information by AFRRRI personnel. The remainder of the field measurement data will be documented in the near future.

2. EQUIPMENT

The sensor used for measuring the high impedance electric fields was the IITRI-fabricated high impedance electric field probe.* Conversion tables are used to convert the output voltage readings of the probe to equivalent electric field levels. The meter used in conjunction with the probe was the

* V. C. Formanek, "An Improved ELF Electric Field Probe,"
IIT Research Institute Technical Memorandum E6249-2 (March 1974).

Hewlett-Packard 3581A signal wave analyzer. The HP3581A functions as a frequency selective voltmeter, and was factory modified for a 1 Hz bandwidth and battery operation. For these measurements the HP3581A was used with a 3 Hz bandwidth. The electric field probe was zeroed and calibrated at regular intervals during the measurements and remained constant to within about one percent.

3. VERTICAL ELECTRIC FIELD SIMULATOR

3.1 Physical Layout

A set of 45 Hz electric field data was taken to supplement field mapping data which were obtained on 14 March 1975. In order to make these measurements after the completion of the experiment, AFRRRI personnel reconstructed one of the vertical electric field simulators used in the initial setup. This simulator was positioned in the approximate location of chambers 3 and 4 in the same ELF exposure room used in the experiment. Figure 1 presents the location of the points where data were taken in test chambers 3 and 4. Figure 2 gives the layout of ELF exposure Room No. 1440, and the positioning of the test chambers. The temporary routing of the 110 VAC wiring and ballast board for the chamber fluorescent lights is also shown. It was determined at the time of the simulator reconstruction that the fluorescent light fixtures for the chambers were not grounded during the period of the experiment.

3.2 45 Hz Electric Field Measurements

Three perpendicular components of the high impedance 45 Hz electric field generated by the simulators were measured at each of the 36 test points shown in Figure 1 in the orientation described. The measurements were made at a height of approximately three inches above the lower plate of the simulator. The data from these measurements for chambers 3 and 4 are presented in Tables 1 and 2, respectively. The magnitude of the vector sum of the three electric field components, computed as the square root of the sum of the squares of the three components, is also given for each test position to indicate the maximum value of 45 Hz electric field present.

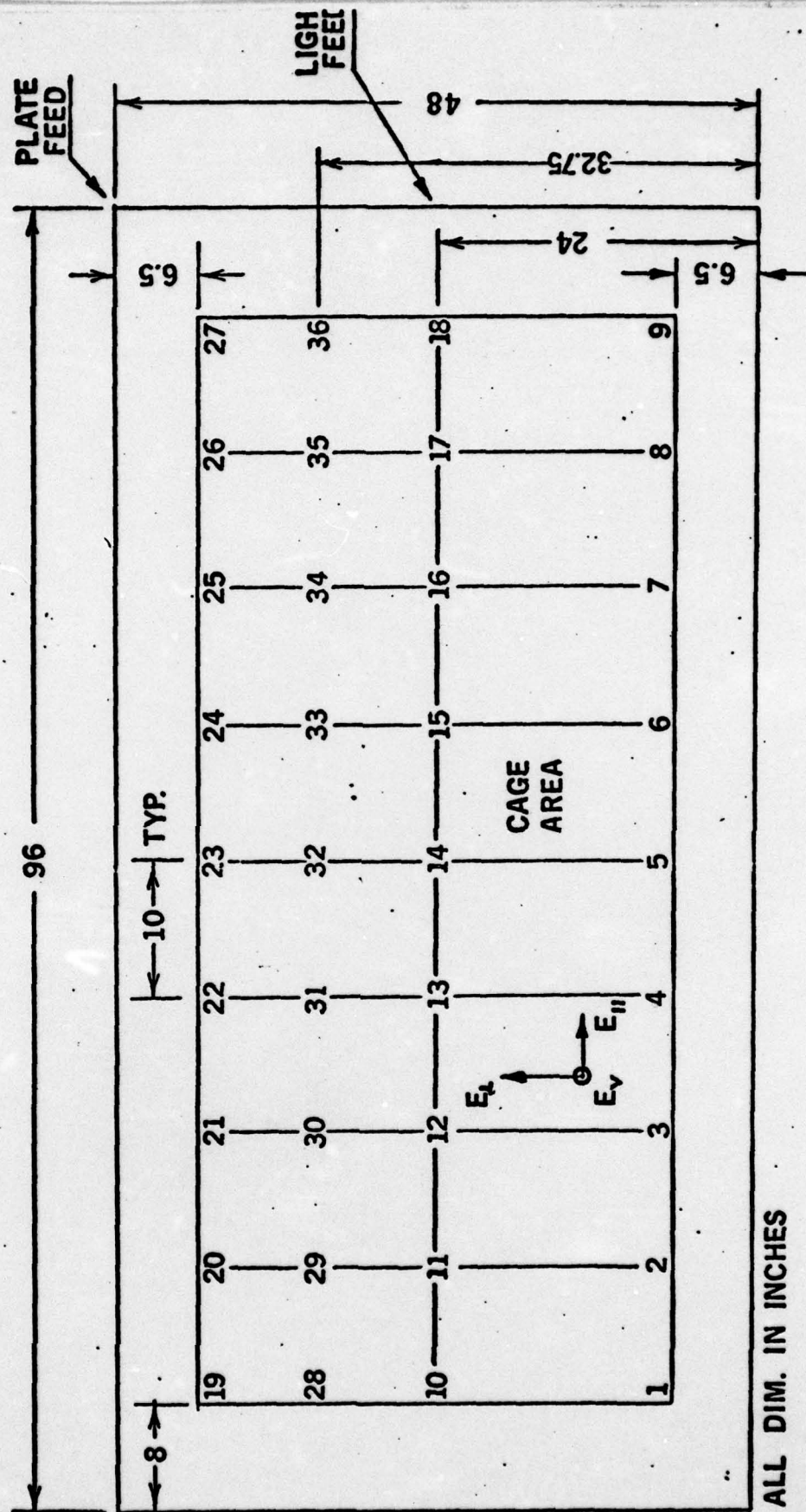

ALL DIM. IN INCHES

FIG. 1 ELF ELECTRIC FIELD SIMULATOR: RM. 1440

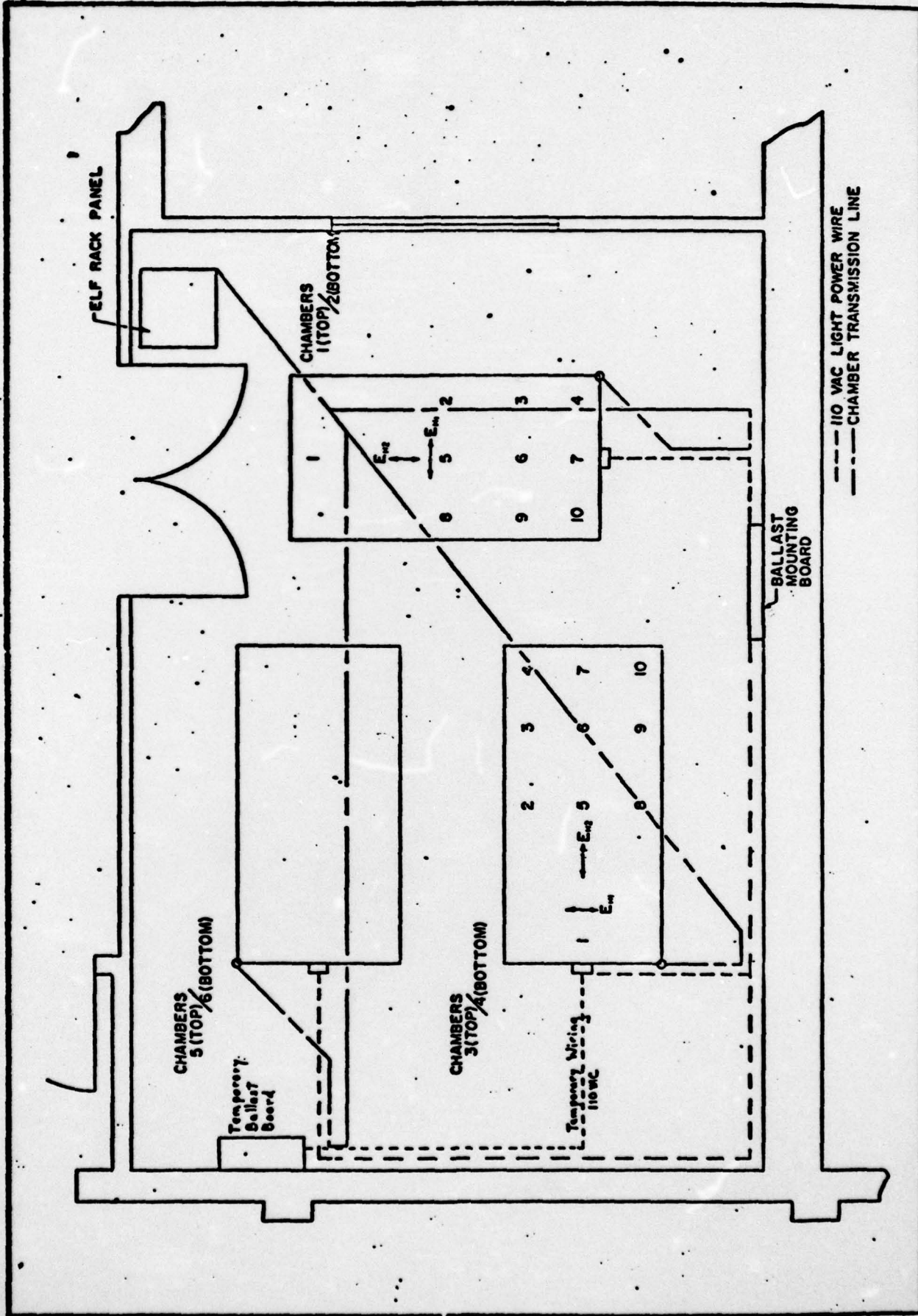

ARMED FORCES RADIOBIOLOGY RESEARCH INSTITUTE FACILITIES & ENGINEERING DIVISION	FIGURE 2 RM. 1440: ELF EXPOSURE ROOM		DRAWN BY BRUCE IMBACH	DATE 8/31/76	SHEET 13
			APPROVED:	SCALE 0127m = 3048m	OF 13

Table 1
45 Hz ELECTRIC FIELD LEVELS IN VERTICAL ELECTRIC FIELD SIMULATOR #3 (TOP)

Position	E_{vert} V/m	$E_{ }$ V/m	E_{\perp} V/m	$ E $ V/m	Position	E_{vert} V/m	$E_{ }$ V/m	E_{\perp} V/m	$ E $ V/m
*					*				
1	9.32	0.248	0.248	9.33	19	9.32	0.234	0.199	9.33
2	9.44	0.224	0.273	9.45	20	9.57	0.180	0.236	9.57
3	9.57	0.217	0.335	9.58	21	9.57	0.242	0.199	9.58
4	9.57	0.255	0.311	9.58	22	9.57	0.230	0.234	9.58
5	9.57	0.230	0.342	9.58	23	9.57	0.217	0.230	9.58
6	9.57	0.273	0.273	9.58	24	9.57	0.217	0.298	9.58
7	9.57	0.255	0.323	9.58	25	9.44	0.234	0.217	9.45
8	9.44	0.242	0.286	9.45	26	9.44	0.093	0.230	9.44
9	9.32	0.137	0.273	9.33	27	9.44	0.149	0.186	9.44
*					*				
10	9.57	0.230	0.236	9.58	28	9.57	0.217	0.155	9.57
11	9.69	0.267	0.261	9.70	29	9.69	0.199	0.180	9.69
12	9.69	0.261	0.255	9.70	30	9.69	0.298	0.217	9.70
13	9.69	0.234	0.199	9.69	31	9.69	0.248	0.199	9.70
14	9.69	0.230	0.280	9.70	32	9.69	0.234	0.168	9.69
15	9.69	0.280	0.205	9.70	33	9.69	0.230	0.174	9.69
16	9.69	0.292	0.267	9.70	34	9.69	0.234	0.149	9.69
17	9.69	0.304	0.199	9.70	35	9.57	0.093	0.180	9.57
18	9.57	0.149	0.106	9.57	36	9.57	0.087	0.174	9.57
					*				

* Indicates a probe calibration point; measurements made with room lights on, chamber lights off; plate voltage \approx 5 volts.

Table 2
45 Hz ELECTRIC FIELD LEVELS IN VERTICAL ELECTRIC FIELD SIMULATOR #4 (BOTTOM)

Position	E_{vert} V/m	$E_{ }$ V/m	E_{\perp} V/m	$ E $ V/m	Position	E_{vert} V/m	$E_{ }$ V/m	E_{\perp} V/m	$ E $ V/m
*					*				
1	9.81	0.106	0.174	9.81	19	9.69	0.081	0.205	9.69
2	10.1	0.186	0.143	10.1	20	9.94	0.099	0.280	9.94
3	10.2	0.236	0.205	10.2	21	10.1	0.149	0.255	10.1
4	10.2	0.242	0.199	10.2	22	10.1	0.163	0.168	10.1
5	10.3	0.261	0.186	10.3	23	10.2	0.130	0.163	10.2
6	10.2	0.230	0.186	10.2	24	10.2	0.217	0.199	10.2
7	10.2	0.230	0.161	10.2	25	10.1	0.236	0.186	10.1
8	10.1	0.323	0.106	10.1	26	9.94	0.236	0.236	9.95
9	9.57	0.342	0.031	9.58	27	9.81	0.217	0.205	9.81
*					*				
10	10.2	0.056	0.199	10.2	28	9.94	0.087	0.093	9.94
11	10.4	0.155	0.205	10.4	29	10.2	0.155	0.304	10.2
12	10.6	0.174	0.217	10.6	30	10.3	0.242	0.311	10.3
13	10.6	0.193	0.236	10.6	31	10.3	0.211	0.230	10.3
14	10.6	0.292	0.199	10.6	32	10.4	0.323	0.293	10.4
15	10.6	0.242	0.186	10.6	33	10.3	0.255	0.296	10.3
16	10.4	0.242	0.199	10.4	34	10.3	0.230	0.292	10.3
17	10.3	0.261	0.255	10.3	35	10.3	0.261	0.242	10.3
18	10.2	0.329	0.193	10.2	36	10.1	0.246	0.261	10.1
					*				

*Indicates a probe calibration point; measurements made with room lights on, chamber lights off; plate voltage = 5 volts.

The 45 Hz electric field measurements were taken with the fluorescent room lights on and the chamber fluorescent lights off. The voltage applied to the plates of the simulators during the measurements was approximately 5 volts.

4. DISCUSSION AND COMMENTS

In general, the vertical component of the generated electric field was found to be quite uniform, with only about four percent variation over the test area. The horizontal components of the electric field were always less than four percent of the vertical component. The field levels in the upper chamber (#3) were slightly lower than those in the lower chamber (#4); however, this may be due to the slightly greater plate separation in the upper chamber (18.875 inches) compared to the lower chamber (18.375 inches). For the applied plate voltage of five volts, and the upper and lower plate separations given, the expected vertical electric field levels would be 10.4 V/m and 10.7 V/m, respectively. These compare well with the 9.7 V/m and 10.6 V/m levels measured in the chamber centers.

As the 45 Hz measurements were made with the chamber fluorescent lights off, a set of measurements was made in Position 10 in the upper chamber, to determine if the 60 Hz ambient fields had any interaction with the 45 Hz fields. Measurements taken with the simulators energized showed no difference in readings with the chamber lights on or off.

