

AD-A035 976

ARMY ENGINEER WATERWAYS EXPERIMENT STATION VICKSBURG MISS F/G 13/2
USE OF CONCENTRATION INDEX FOR PAVEMENT DESIGN.(U)
FEB 74 R G AHLVIN , Y T CHOU, H H ULERY
WES-MP-S-74-4

UNCLASSIFIED

NL

1 OF 1
AD-A
035 976



END
DATE
FILMED
3-26-77
NTIS

U.S. DEPARTMENT OF COMMERCE
National Technical Information Service

AD-A035 976

USE OF CONCENTRATION INDEX FOR PAVEMENT DESIGN

ARMY ENGINEER WATERWAYS EXPERIMENT STATION
VICKSBURG, MISSISSIPPI

FEBRUARY 1974

A7
V34 ml
No. S-74-4

US-CE-C Property of the United States Government

ADA035976



MISCELLANEOUS PAPER S-74-4

USE OF CONCENTRATION INDEX FOR PAVEMENT DESIGN

by

R. G. Ahlvin, Y. T. Chou, H. H. Ulery, Jr.

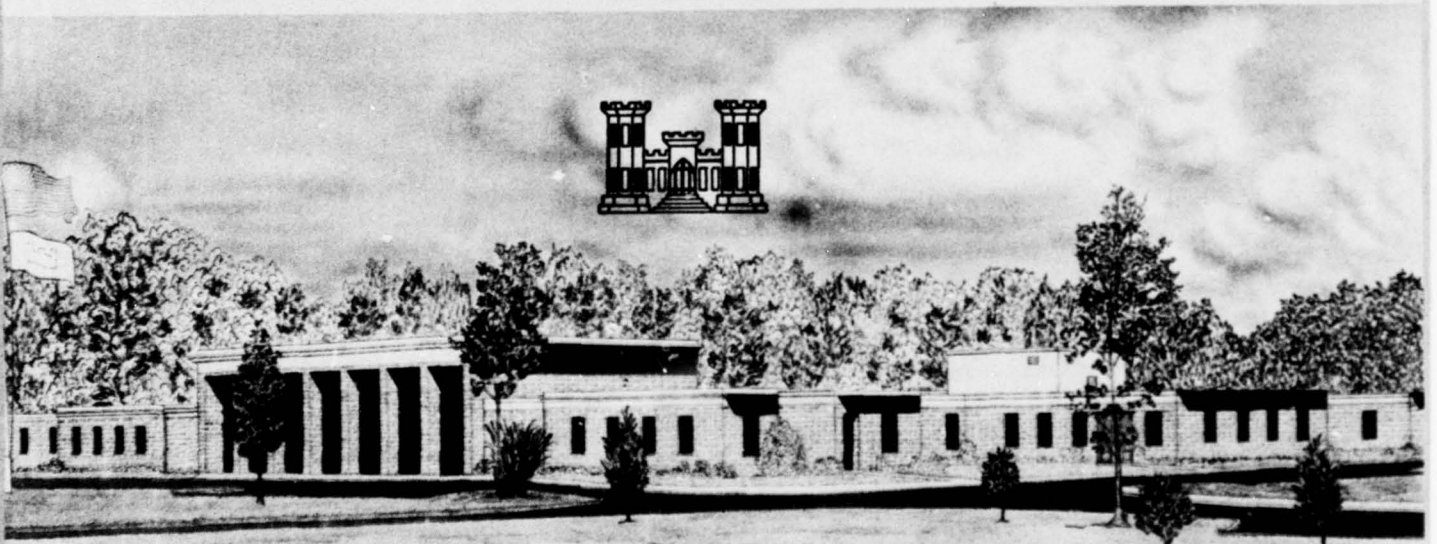

REPRODUCED BY
NATIONAL TECHNICAL INFORMATION SERVICE
U. S. DEPARTMENT OF COMMERCE
SPRINGFIELD, VA. 22161

February 1974

Published by U. S. Army Engineer Waterways Experiment Station
Soils and Pavements Laboratory
Vicksburg, Mississippi

APPROVED FOR PUBLIC RELEASE; DISTRIBUTION UNLIMITED

Unclassified

Security Classification

DOCUMENT CONTROL DATA - R & D		
<small>(Security classification of title, body of abstract and indexing annotation must be entered when the overall report is classified)</small>		
1. ORIGINATING ACTIVITY (Corporate author) U. S. Army Engineer Waterways Experiment Station Vicksburg, Miss.		2a. REPORT SECURITY CLASSIFICATION Unclassified
		2b. GROUP
3. REPORT TITLE USE OF CONCENTRATION INDEX FOR PAVEMENT DESIGN		
4. DESCRIPTIVE NOTES (Type of report and inclusive dates) Final report		
5. AUTHOR(S) (First name, middle initial, last name) Richard G. Ahlvin Harry H. Ulery, Jr. Y. T. Chou		
6. REPORT DATE February 1974	7a. TOTAL NO. OF PAGES 30	7b. NO. OF REFS 14
8a. CONTRACT OR GRANT NO.	8b. ORIGINATOR'S REPORT NUMBER(S) Miscellaneous Paper S-74-4	
8c. PROJECT NO.		
c.	8d. OTHER REPORT NO(S) (Any other numbers that may be assigned this report)	
d.		
10. DISTRIBUTION STATEMENT Approved for public release; distribution unlimited.		
11. SUPPLEMENTARY NOTES This paper is published in "Journal, Engineering Division, American Society of Civil Engineers," Vol 99, No. 7E5, Feb 1974.		12. SPONSORING MILITARY ACTIVITY
13. ABSTRACT The application of the concentration index to pavements is illustrated. The problem with the design of flexible airfield pavements under newly developed jumbo-jet aircraft, as represented by the Lockheed C-5A Galaxy and the Boeing 747, is discussed. These aircraft are equipped with extremely large multiple-wheel landing gears. It is found that the CBR design equation can be used to evaluate the pavement performance under multiple-wheel gear assemblies when the equivalent single-wheel load (ESWL) is computed by the concentration index method. The concentration index is approximately independent of the load, gear configuration, and soil strength but varies with the depth.		

DD FORM 1473
1 NOV 66

REPLACES DD FORM 1473, 1 JAN 66, WHICH IS OBSOLETE FOR ARMY USE.

Unclassified
Security Classification

14 KEY WORDS	LINK A		LINK B		LINK C	
	ROLE	WT	ROLE	WT	ROLE	WT
Aero-space transport						
Aircraft						
Boussinesq theory						
Concentration Index						
Deflection						
Deflection basin						
Elasticity						
Flexible pavements						
Jumbo-Jet						
Landing gears						
Layered systems						
Multiple-wheels						
Pavement design						
Stresses						

Unclassified

(a)

Security Classification

Destroy this report when no longer needed. Do not return
it to the originator.

The findings in this report are not to be construed as an official
Department of the Army position unless so designated
by other authorized documents.

TA 7

W34m

NO. S-74-4

FOREWORD

This paper is published in the "Journal of the Transportation Engineering Division, American Society of Civil Engineers," Vol 99, No. TE5, Feb 1974.

Directors of the U. S. Army Engineer Waterways Experiment Station during the conduct of this study and preparation of this report were BG E. D. Peixotto, CE, and COL G. H. Hilt, CE. Technical Director was Mr. F. R. Brown.

SUMMARY

The application of the concentration index to pavements is illustrated. The problem with the design of flexible airfield pavements under newly developed jumbo-jet aircraft, as represented by the Lockheed C-5A Galaxy and the Boeing 747, is discussed. These aircraft are equipped with extremely large multiple-wheel landing gears. It is found that the CBR design equation can be used to evaluate the pavement performance under multiple-wheel gear assemblies when the equivalent single-wheel load (ESWL) is computed by the concentration index method. The concentration index is approximately independent of the load, gear configuration, and soil strength but varies with the depth.

Preceding page blank

USE OF CONCENTRATION INDEX FOR PAVEMENT DESIGN

By R. G. Ahlvin,¹ Y. T. Chou,² and H. H. Ulery, Jr.³

INTRODUCTION

With the advent of the jumbo-jet aircraft, as represented by the Lockheed C-5A Galaxy and the Boeing 747, engineers are faced with supporting three-quarter million pounds and larger aircraft on pavement facilities. The design concept has been changed to a great extent because of the effect of wheel interaction and large deflection basins resulting from these extremely large multiple-wheel landing gears. The results of the multiple-wheel heavy gear load (MWHGL) tests recently completed at the Waterways Experiment Station (WES) (1) showed that the pavement behavior under heavy loads is apparently nonlinear as compared to the nearly linear behavior under light loads. The results also showed the current criteria for flexible pavements are adequate for the design of thin pavement structures, but application of the criteria results in over-designed thick pavement structures. It is apparent that present methodology of evaluating the equivalent single-wheel load (ESWL) is not applicable to the multiple-wheel heavy gear loads. There is a need to investigate the cause of the overestimation and, hopefully, to develop a method of modify the current criteria. This paper presents the results of using the concentration index

¹Supv. Civ. Engr., Chief, Pavement Research Laboratory, Soils Division, U. S. Army Engineer Waterways Experiment Station, Vicksburg, Miss.

²Research Civ. Engr., Pavement Research Laboratory, Soils Division, U. S. Army Engineer Waterways Experiment Station, Vicksburg, Miss.

³Supv. Civ. Engr., Chief, Concepts and Theory Section, Pavement Research Laboratory, Soils Division, U. S. Army Engineer Waterways Experiment Station, Vicksburg, Miss.

method to evaluate the ESWL for airfield flexible pavements under multiple-wheel gear loads.

NATURE OF PROBLEM

Comparisons of predicted and observed pavement behavior

In the analysis of pavement structures to compute the stresses and displacements due to surface wheel loads, Boussinesq's homogeneous solid theory and Burmister's layered solid theory have commonly been used. The basic assumptions behind the Boussinesq solutions are that the materials which constitute the media are homogeneous, isotropic, and perfectly linearly elastic. The same assumptions are employed for layered solid theory for materials in each layer with the addition that the layers are assumed to be continuously in contact and act together as a composite medium; consequently, at the interfaces of a layered system, the normal and shear stresses and the vertical and horizontal displacements are the same in both layers. The applicability of these solutions to a particular pavement structure depends upon the nature and physical properties of the materials and how well they can be judged to satisfy the assumptions.

Very few materials, if any, are homogeneous, isotropic, and linearly elastic. Also, very limited amounts of basic research and experiments have been done to justify the validity of the assumptions of continuity in layered systems. The continuity of vertical stress and vertical displacement along interfaces in a real pavement seems to be possible; the continuity of shear stress and radial displacement, however, is questionable. The resulting errors in the computed values are apparent and could be very serious.

In spite of many arbitrary assumptions behind the theory, Boussinesq's solution for a homogeneous elastic solid gives fairly good predictions for stress and strain in uniform soil masses. Experiments conducted at WES (2) for the

measurements of stresses and deflections induced in sand and clay test sections by single- and dual-plate loads of various plate sizes and loads have found the measured stresses are generally in good agreement with stresses predicted by the Boussinesq theory while the deflections are not except at great depths. Based on these test results, it was also found that the superposition principle may be considered applicable for conditions similar to those existing in the test sections.

The predictions of stresses and deflections in flexible pavement by the layered theory are not as good as those in a homogeneous soil mass. In most cases, the prediction by the Boussinesq theory gives better results than by the much more sophisticated layered theory, even though the pavement structure is layered in nature.

Based on preliminary results of MWHGL tests, comparison of measured values with computed predictions indicates the following:

a. Measured vertical stresses were generally in excess of those computed from the linear layered theory; the measured vertical stresses along the load axis of a single wheel were in fairly good agreement with those computed from Boussinesq analysis for homogeneous materials.

b. The deflections measured at various depths indicate that both the Boussinesq and layered theories are quite inadequate for the prediction of such deflections.

c. The predicted and measured shapes of stress and deflections basins were distinctly different. The measured stress and deflection basins appear to be more confined to the vicinity of the tire than is indicated by the layered theory. In both stresses and deflections, Boussinesq's solution gives results closer to the measurements than given by the layered theory.

The causes of discrepancies between measurements and predictions based on layered theory have been investigated by many researchers. Vesic (3) concluded that in addition to the anisotropy and the difference in the strength characteristics under compression and tension of the materials, the evident lack of slab action of upper layers, as assumed by the theory, is the main factor.

Although the prediction of maximum stress and deflection under a single wheel is of essence, the precise determination of these quantities at offset distances is also important when multiple-wheel gear loads are considered. It has been the general practice to compute stresses or deflection in a pavement structure induced by a multiple-wheel load assembly by using the superposition principle; i.e., the stress or deflection induced by a group of wheel loads is the linear summation of that induced by each wheel that is loaded separately. From the foregoing discussion, it is apparent that for multiple-wheel gear loads, the computed vertical stress and deflection tend to be overestimated, with increasing difference as the number of wheels is increased. This has a drastic effect on the design and evaluation of pavement structures for multiple-wheel load assemblies. Huang (4) computed the ESWL for dual-wheels based on elastic layered theory and found that the ESWL increases appreciable with the increases in modulus ratio.

The principle of superposition is used by the Corps of Engineers in the flexible pavement method of design to estimate the ESWL, which is defined as the load on a single wheel that results in a vertical deflection of the supporting medium equal to that particular multiple-wheel assembly with the same single-wheel tire contact area. For dual wheels, it has been found that the use of the superposition principle gives results that are within the acceptable limit of error. However, for multiple-wheel heavy gear loads, such as the Boeing 747 and the C-5A, the computed ESWL becomes so large that the current criteria is

too conservative.* It should be noted that the error mentioned above is not directly caused by the use of the superposition principle but by the use of inadequate deflection-offset curves. This can best be explained by the MWHGL test results (1).

Figure 1 shows measured and computed deflection basins at the 12-ft depth in a test section (item 3, reference 1) induced by a single wheel load (30-kip) and a C-5A 12-wheel-gear assembly (360-kip). The gear configuration for the 12-wheel assembly is shown in fig. 2. The computed deflections are plotted in percentage of the maximum values. In both cases, the computed and measured basin shapes are quite different. However, when the superposition principle is used on the measured single-wheel deflection basin (instead of the theoretical one) to compute a 12-wheel basin, the resulting basin is astonishingly close to the measured 12-wheel basin; these are shown by the dots along the measured 12-wheel basin. Similar relations were also found at other depths. Test results shown in fig. 1 verify the remark made in the previous paragraph regarding the source of error.

The superposition principle incorporating the linear theory of elasticity has also been used by others in the computations of maximum stresses and strains under multiple-wheel loads. References 5 and 6 are representative of such usage.

Knowing that the assumptions behind the linear theory of elasticity are inadequate, much effort has been made in recent years to consider the nonlinear characteristics of materials in the layered theory with the hope that nonlinear

nonlinear analyses; therefore, the difference between measurements and prediction is still not reconciled. The conclusions of a representative paper are briefly explained in the next paragraph.

Dehlen and Monismith (7) studied the effects of nonlinear material response on the behavior of pavements under traffic. They measured stresses, strains, and displacements induced by operation of a truck on a full-scale full-depth asphaltic concrete pavement. They compared the measured values with those computed by both linear theory (Shell and finite element solutions) and nonlinear theory (finite element solution). Based on the results of analysis, Dehlen and Monismith found that there was relatively small difference between the results of the linear and nonlinear analyses and that the maximum surface deflections indicated by the theoretical analyses were 17 to 32 percent larger than the measured deflections, with the results of the nonlinear finite element solution deviating the most from measurements. As stated by the authors, "Less satisfactory, however, is the marked difference in the deflection patterns, the theoretical deflections yielded by all three analyses being far more concentrated than those measured."

It should be noted that the nonlinear finite element analysis is presently limited to the single-wheel load only; the analysis of multiple-wheel loads is not possible because of limitations in the capacity of computer facilities. Based on the foregoing discussion, it is very doubtful that the nonlinear finite element analysis, in its present form, would predict the pavement response to multiple-wheel loads even if computer facilities had the required capacity.

Equivalent single-wheel load

In the development of multiple-wheel CBR design criteria (8) from the proven single-wheel criteria, the concept of ESWL was adopted. The ESWL was estimated

from single-wheel curves of deflection versus offset by the use of the superposition principle. It was established that theoretical deflections could be used to show the equivalency. The use of ESWL for design purposes was justified based upon the facts that (a) a single-wheel load that yields the same maximum deflection as a multiple-wheel load will produce equal or more severe strains in the subgrade or base than will the multiple-wheel load; and (b) the slopes of the deflection versus offset curves for the ESWL are equal to or steeper than those for the multiple-wheel load at equal depths. Pertinent test data collected at the WES have indicated that the multiple-wheel design criteria apply well to dual-wheel assemblies and generally give results on a slightly conservative side.

However, the results from the MWHGL tests (1) have shown that the present criteria for flexible airfield pavements are overconservative for newly developed heavy aircraft that are equipped with extremely large multiple-wheel loading gears. Figure 3 shows the results of multiple-wheel traffic tests (1). The single-wheel CBR design curve is well validated based on numerous test data; the other two lines are design curves developed for twin-tandem and 12-wheel (C-5A) assemblies, respectively (Fig. 2). These lines were drawn along test points determined according to the following procedures:

a. For each test section, the ESWL is computed according to the present Corps of Engineer method. The procedure can be found in the Appendix of reference 8 and is not repeated in this paper. Based on the ESWL determined, the capacity thickness t is computed from the CBR equation:

$$t = \sqrt{\frac{ESWL}{8.1 \text{ CBR}} - \frac{A}{\pi}} \quad (1)$$

where A is the measured tire contact area.

b. The percent of design thickness is determined as the ratio of the thickness of the test section to the thickness required for capacity operation.

It is seen that design curves for MWHGL are separated from the single-wheel CBR design curve. For example, 80 percent of design thickness was required for a single-wheel load designed at 1000 coverages, but only 70 and 60 percent were required at the same coverage level for twin-tandem and 12-wheel assemblies, respectively. Apparently, if the method used to compute the ESWL was correct -- as evaluated from the performance of the pavement under the particular MWHGL -- test points should fall close to the single-wheel CBR design curve, and there would be no need for the existence of other design curves. In other words, a methodology to determine the ESWL ought be developed by which individual design curves for MWHGL can be eliminated, and only a unique curve is required for all single- and multiple-wheel assemblies.

To develop the methodology, one has to realize that the error is caused from overestimation of ESWL. The overestimation was derived probably from two sources:

a. Deflection may not be the best and only factor for the basis of establishing the ESWL for MWHGL. The performance of a pavement depends not only on deflection but also on many other factors, such as the slopes of deflection basins as mentioned previously; the deflection basin under a C-5A main gear is flatter (percentage wise) than that under the computed ESWL even though they have the same maximum deflection by definition, indicating different shearing strains experienced in the pavement under single and 12 wheels.

b. Theoretical single-wheel deflection-offset curves are not adequate to determine the ESWL when a large number of wheels are involved. The discrepancies are not particularly caused by the use of the superposition principle but mainly by the inadequate deflection offset curves as discussed previously.

It is very difficult, if not impossible, to improve these two points at the present time because of insufficient knowledge of the structural behavior of

airfield flexible pavements and the present limited capacity of computer facilities. The ESWL should be evaluated by considering many factors other than just deflections. However, this concept cannot readily be carried out into a simple and useful form because not only are these factors not theoretically predictable even with fair accuracy, but the interaction of these factors relating to the performance of the pavement under a particular gear assembly is not known; therefore, a completely different approach has to be used to reach the goal of a single design curve. It is thus the purpose of this study to look into possibilities of using the concentration index method to solve the problem.

CONCENTRATION INDEX

The theory and concept of the concentration index for an isotropic, nonuniform soil mass under an axisymmetric loading are presented in Appendix I and are not discussed here. The method, which was actually a semi-empirical modification of Boussinesq's theory of elastic solids, was developed independently by Griffith (9) and Fronhlich (10). The work was later further studied by Ohde (11), Holl (12), and Brandt (13) and was used by others to compare with experimental data in a number of studies (14, 2). With the concentration index, the vertical stress σ_z corresponding to the Boussinesq equation becomes (Fig. 4):

$$\sigma_z = \frac{nPz^n}{2\pi R^{n+2}} \quad (2)$$

The parameter n is the concentration index, the value of which depends upon the properties of the soil mass. For the case $n = 3$, the expression reduces to precisely that given by Boussinesq. For values different from 3, the material does not satisfy the assumptions of the theory of elasticity.

Since the criteria for determining ESWL are based upon vertical deflections, it is necessary to apply the concept of the concentration index to vertical

deflections instead of vertical stress. This can be done either by (a) deriving the expressions for deflections from equation 2 using appropriate stress-strain relations or (b) modifying the Boussinesq equation of vertical deflection into a form similar to equation 2 and determining the concentration index from experimental data.

The first method is not feasible based on reasons that (a) the conditions in equations 8 and 9 of Appendix I are generally difficult to meet for most soils and (b) if the conditions are either met or assumed, it is doubtful that deflections so derived would match measured values because of the inherited errors in the use of Hook's law in relating stresses to strains and then to deflections (see discussions in Appendix I).

From these discussions and also realizing that the use of the concentration index is no more than a semi-empirical modification of Boussinesq's equations, the second method seems to be best suited for our purposes. The modified equation for Boussinesq's vertical deflection W under a point load P may be written as

$$W = \frac{P(1+\nu)}{2\pi E} \left(\frac{z^{n-1}}{R^n} + \frac{2(1-\nu)}{R^{n+2}} \right) \quad (3)$$

where ν is the Poisson's ratio and the parameter n is the concentration index. For $n = 3$, the equation is the expression for the vertical deflection as that obtained by Boussinesq for a semi-infinite solid satisfying the assumptions of the theory of elasticity.

A numerical method was used to compute the deflections in such a medium under a uniformly distributed circular loaded area. The loaded area was equally divided into 400 small elements and each element was considered as a point load. The total deflection was then the sum of those deflections induced by all point loads. This procedure was found to be sufficiently accurate except at locations

very near the center of the load. Figure 5 depicts the relations of deflection versus offset for different values of the concentration index n at two different depths. It is seen that by varying the concentration index, the shape of the computed deflection basin in the soil can be changed.

ESWL evaluated from traffic test data

As explained previously, the ESWL's computed from current method are too large and consequently cause the overdesign of pavements. The correct ESWL evaluated from traffic test data (or performance) may be computed as explained in the following paragraphs.

Required thicknesses. The design thickness for a particular gear configuration at different coverage levels should be determined first. They are computed from CBR equations and design curves for MWHGL shown in Fig. 3. The computation procedures are listed as follows:

- a. For a given gear configuration at a particular coverage level, an initial thickness t_e is estimated; the ESWL based on current criteria (8) is computed.
- b. Compute the thickness t for capacity operation from equation 1.
- c. If the ratio t_e/t in percentage is not close to the value shown in design curves for MWHGL in Fig. 3, estimate another value for t_e and repeat the entire procedure. Figure 6 depicts the relations of thickness versus coverage level for several different gear configurations.

ESWL. From the required thicknesses (Fig. 6) at a particular coverage level, the percent design thickness can be read from the single-wheel CBR design curve. The corresponding thickness for capacity operation is determined and the desired ESWL is computed from equation 1.

Example.

a. Required. Determine the required thickness t and the ESWL based on performance for a C-5A 12-wheel-gear assembly designed at a 1000-coverage level for a subgrade soil of 4 CBR.

b. Solution.

(1) A total pavement thickness of 35.5 in. (t_e) is first assumed; the ESWL for the assumed pavement thickness computed from the current method is 94.6 kips (see reference 8 for procedures). The thickness for capacity operation, t , is computed from equation 1 and is equal to 53.4 in. The ratio t_e/t is equal to 65.6 percent, which is very close to the percentage shown in the design curve in Fig. 3 for 12 wheels at the 1000-coverage level, indicating the pavement thickness is correct.

(2) The percentage of design thickness at the same coverage level is read from the single-wheel CBR design curve and is equal to 81 percent; the corresponding thickness for capacity operation t is equal to $\frac{35.5}{0.81} = 44$ in. The correct ESWL is computed as follows:

$$\text{ESWL} = 8.1 \text{ CBR} \left(\frac{A}{\pi} + t^2 \right) = 65.5 \text{ kips} \quad (4)$$

which is substantially smaller than 94.6 kips evaluated by the current method. It should be noted that the ESWL 65.6 kips is evaluated from the observed pavement performance, while the ESWL 94.6 kips is computed from the Boussinesq theoretical solution.

Determination of n values

For a particular gear configuration, the curves of ESWL versus depth for different values of the concentration index n can be drawn. Figure 7 shows such curves for one twin-tandem component of Boeing 747 assembly and a C-5A 12-wheel-gear assembly, respectively. For $n = 3$, the curves are that of

Boussinesq. The same principle was used to determine the curves for the concentration index other than 3.

Once the family of curves is determined, the ESWL determined based on test data can be added to the curves at different depths as shown in Fig. 7 by the dotted lines. The required n values at different depths can thus be read from the curves. It is seen that n is not a constant but increases with increasing depth. Also, variations in n values were observed for different loads, soil strengths, and number of wheels. Figure 8 shows these variations with depth; the coordinate $n = 3$ is the elastic case. For design purposes, a best-fit straight line was drawn through the curves; the equation of the line may be written as

$$n = 3 + 0.0113 z \quad (5)$$

where z is the depth in inches. In so doing, the value of n varies only with depth z and becomes independent of the load, soil strengths, and number of wheels. In drawing the straight line, emphasis was placed upon lower concentration indexes because the change in percent ESWL is smaller at a higher concentration index than that at a lower one; this can be clearly seen in Fig. 7.

Attempts were made to use equation 5 to eliminate design curves for MWHGL in Fig. 3. The procedures used are listed as follows:

a. For a design thickness and coverage level (Fig. 6), the n values are calculated from equation 5.

b. For the particular gear configuration, the ESWL at the specified depth can be determined from the ESWL-depth-concentration index curves as shown in Fig. 7.

c. With the ESWL so determined, the thickness for capacity operation can be determined from equation 1. The percent design thickness is the ratio of the design thickness to that for capacity operation.

The computed results for various gear configurations, loads, and soil strengths are shown in Figs. 9 and 10. It is seen that most computed results are close to the single-wheel CBR design curve, except the results for the 120-kip twin-tandem assembly at high coverage level (Fig. 9).

CONCLUSIONS

The ESWL evaluated from current method is over-conservative for MWHGL. Based on the analysis and the test conditions analyzed, the CBR design equation can be used to evaluate the pavement performance under MWHGL when the ESWL is computed by the concentration index method. The concentration index is approximately independent of the load, gear configuration, and soil strength but varies with the depth.

APPENDIX I - CONCENTRATION INDEX

The theory of concentration index deals with isotropic, nonhomogeneous solids in which the Poisson's ratio is constant throughout the mass and Young's modulus varies only with depth; in other words, the solid is assumed to be perfectly elastic and isotropic in every horizontal direction but elastically non-homogeneous in a vertical direction. In 1929, Prof. J. H. Griffith (9) of Iowa State College first presented his generalized solution of the Boussinesq problem. The same result was derived independently in 1933 by Dr. O. K. Frohlich (10) in Europe. They gave the following relation for the radial stress σ_R (or the largest principal stress) due to a normal force P at the surface of an incompressible elastic solid (see Fig. 4 in the main text).

$$\sigma_R = \frac{nP}{2\pi R^2} \cos^{n-2} \theta \quad (6)$$

where $R^2 = r^2 + z^2$ and n is called the concentration index because it determines the intensity of the pressure on horizontal sections beneath a given point load P . By varying the value of n , the distribution of stresses in the solid can be changed. For the case $n = 3$, equation 6 reduces to precisely that given by Boussinesq. In addition to σ_R , the other components of stress are ($n > 2$).

$$\sigma_z = \frac{nPz^n}{2\pi R^{n+2}}, \quad \sigma_r = \frac{nPz^{n-2}r^2}{2\pi R^{n+2}}, \quad \sigma_\theta = 0, \quad \tau_{rz} = \frac{nPz^{n-1}r}{2\pi R^{n+2}} \quad (7)$$

Ohde (11) made a thorough study of the general applicability of equations 6 and 7. He first found that the generalized stresses of equation 7 satisfy the equilibrium equation for an axially symmetric loading and the boundary conditions; i.e., the total pressure on every horizontal section through the solid must be equal to the point load P . However, the stresses do not satisfy the compatibility

equations (in terms of stresses) for an isotropic medium having constant elastic moduli. The compatibility equation in terms of stresses was obtained by substituting the linear Hooke's law into the compatibility equation in terms of strain components.

To satisfy compatibility, Ohde (11) stated that the following relation had to be satisfied:

$$n - 1 = \lambda + 2 = 1/\nu \quad (8)$$

where ν is Poisson's ratio and λ is an exponent which describes the manner of variation of E with depth and is defined by

$$E = E_0 z^\lambda \quad (9)$$

where E_0 is the modulus of elasticity at $z = 1$. With these restrictions, equation 7 is found to be entirely consistent with all the requirements of elastic theory.

It should be noted that the compatibility equations satisfied by the generalized stresses (equation 7) are associated with linear Hooke's law. When a particular concentration index is selected that can match the measured stress distribution, the derived expressions for displacements may not be able to match the measured displacements because of the use of linear Hooke's law.

APPENDIX II - REFERENCES

1. Ahlvin, R. G., et al., "Multiple-Wheel Heavy Gear Load Pavements Tests," Technical Report S-71-17, Vol I-IV, November 1971, U. S. Army Engineer Waterways Experiment Station, CE, Vicksburg, Miss.
2. U. S. Army Engineer Waterways Experiment Station, CE, "Investigations of Pressures and Deflections for Flexible Pavements," Report 1, "Homogeneous Clayey-Silt Test Section," Report 4, "Homogeneous Sand Test Section," Technical Memorandum No. 3-323, March 1951 (1), December 1954 (4), Vicksburg, Miss.
3. Vesic, A., "Theoretical Analysis of Structural Behavior of Road Test Flexible Pavements," Report 10, National Cooperative Highway Research Program, June 1962.
4. Huang, Y. H., "Computation of Equivalent Single-Wheel Loads Using Layered Theory," Highway Research Reocrd No. 291, 1969.
5. Deacon, J. A., "Equivalent Passages of Aircraft with Respect to Fatigue Distress of Flexible Airfield Pavements," presented at the Annual Meeting of the Association of Asphalt Paving Technologists, Oklahoma City, 15-17 February 1971.
6. Witczak, M. W., "Design Analysis - Full Depth Asphalt Pavement for Dallas-Fort Worth Regional Airport," Research Report 70-3, The Asphalt Institute, College Park, Maryland, November 1970.
7. Dehlen, G. L., and Monismith, C. L., "The Effect of Non-Linear Material Response on the Behavior of Pavements Under Traffic, Highway Research Board No. 310, 1970.
8. Foster, C. R., and Ahlvin, R. G., "Development of Multiple-Wheel CBR Design Curves," Proceedings, American Society of Civil Engineers, Journal of Soil Mechanics and Foundations Division, Paper 1647, May 1958.
9. Griffith, J. H., "The Pressures Under Substructures," Engineering and Contracting, Vol 1, 1929, p 113.
10. Frohlich, O. K., << Drukverteilung in Baugrunde >> , Julius Springer, Berlin, 1934 (copies of English translation are available at WES).
11. Ohde, J., "Zur Theorie der Druckverteilung in Baugrund," Der Bauingenieur, 20, 1939, p. 451, (copies of English translation available at WES).
12. Holl, D. L., "Stress Transmission in Earths," Proceedings, Highway Research Board, pp 709-721, 1940.
13. Brandt, E. W., "Concentration Factors for Stress Distribution in Soils," Sols No. 21, Revue Trimestrielle, Tome VI - Deuxieme Trimestre, June 1968.
14. "Accelerated Traffic Test at Stockton Airfield, Stockton, Calif. (Stockton Test No. 2)," prepared by O. J. Porter and Co., Consulting Engineers, Sacramento, Calif. May 1948, for the U. S. Engineer Office, Sacramento, Calif.

APPENDIX III - NOTATION

The following symbols are used in this paper:

A = tire contact area;

CBR = California Bearing Ratio;

E = modulus of elasticity;

E_0 = modulus of elasticity at $z = 1$;

n = concentration index;

P = wheel load;

$$R = \sqrt{r^2 + z^2};$$

r = radial distance;

t = depth or designed pavement thickness;

W = vertical deflection;

z = depth;

θ = angle indicating location of the point;

λ = an exponent;

ν = Poisson's ratio;

σ_R = largest principal stress; and

τ_{rz} = shear stress in r - z direction.

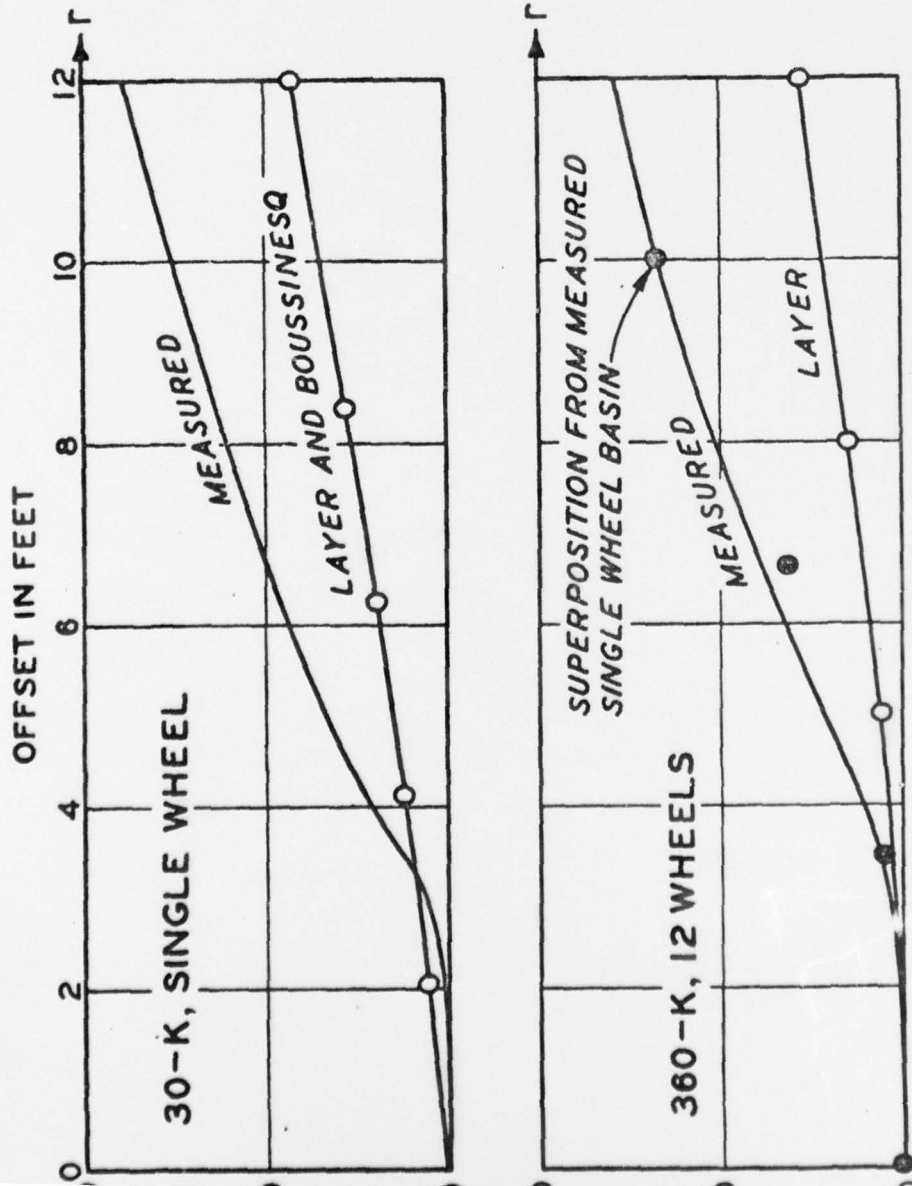
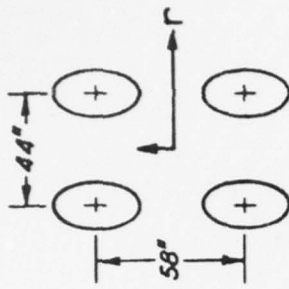
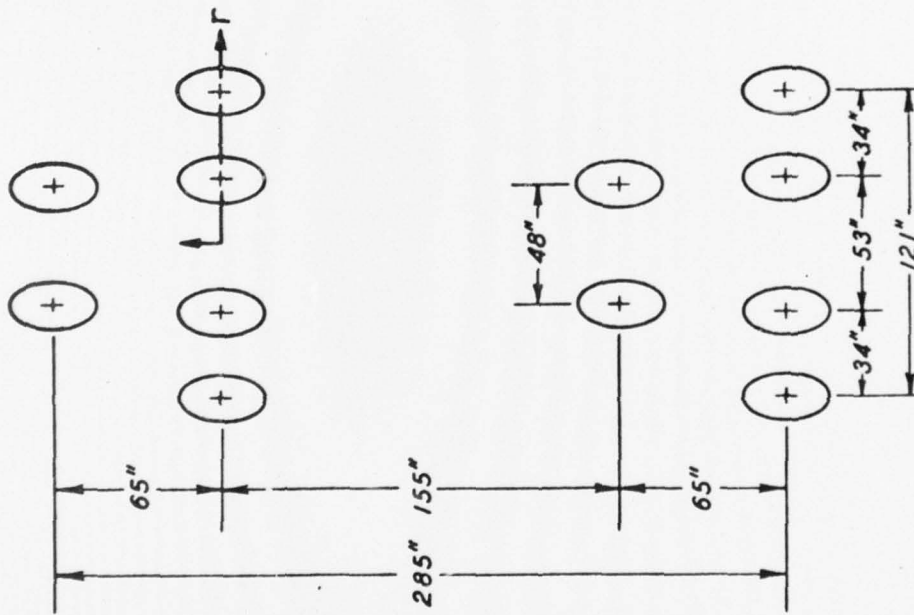

FIG. 1. Theoretical and Measured Deflection Basins for MWHGL Tests



TWIN TANDEM
ONE TWIN-TANDEM
COMPONENT OF
747 ASSEMBLY

TIRE CONTACT
 AREA = 285 IN.



TWELVE WHEEL
ONE MAIN GEAR OF C-5A

Fig. 2. Gear Configurations of C-5A and Boeing 747

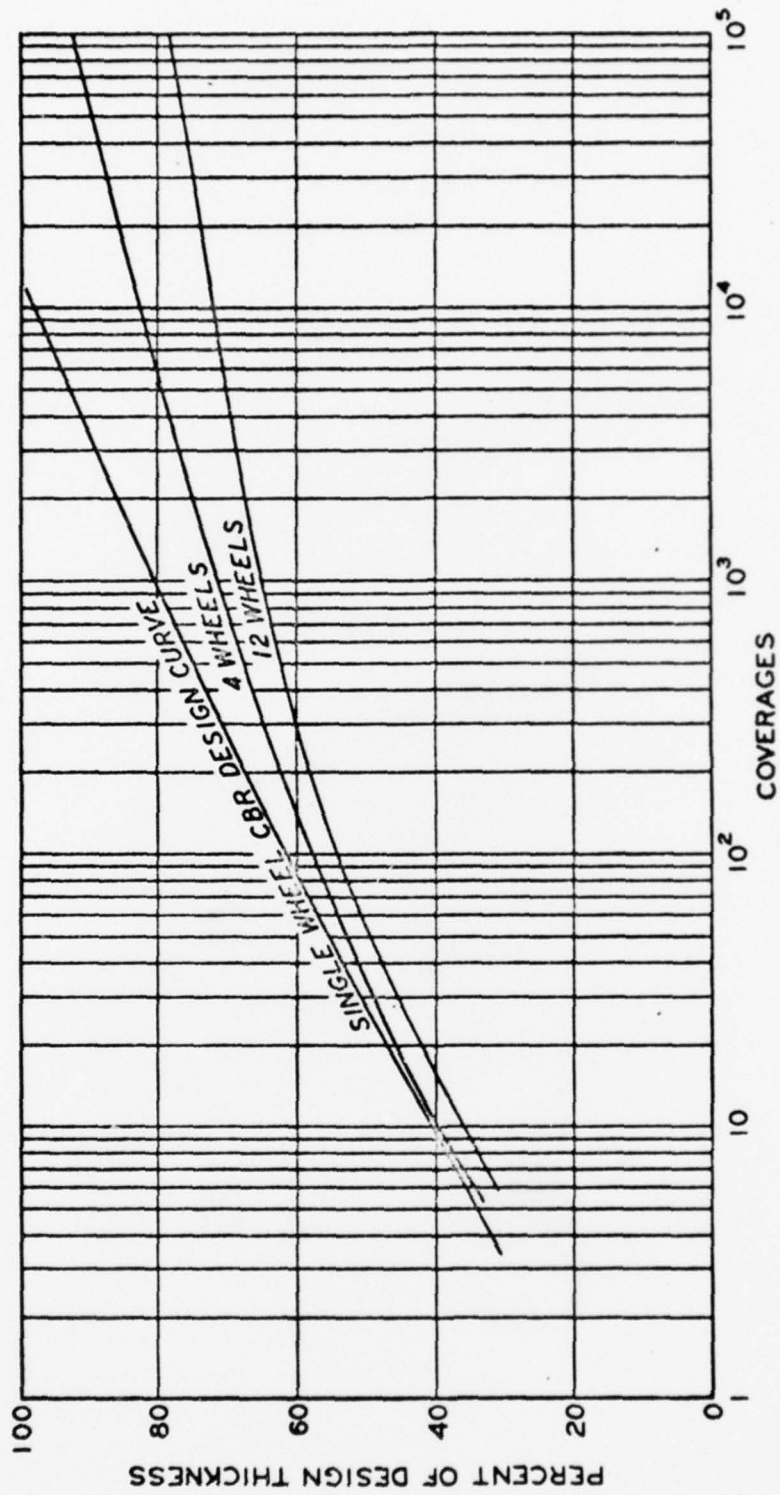

Fig. 3. Results of Multiple-Wheel Heavy Gear Load Traffic Tests With Proposed Thickness Adjustment Curve

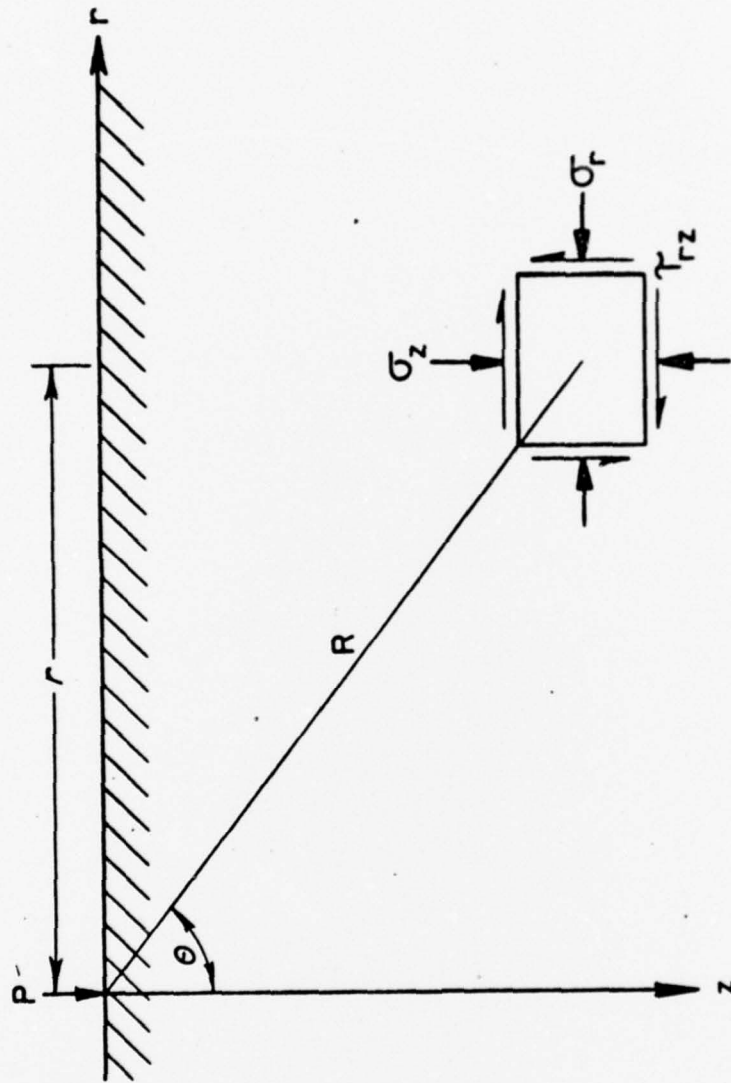

Fig. 4. Coordinate Systems of Stress Components

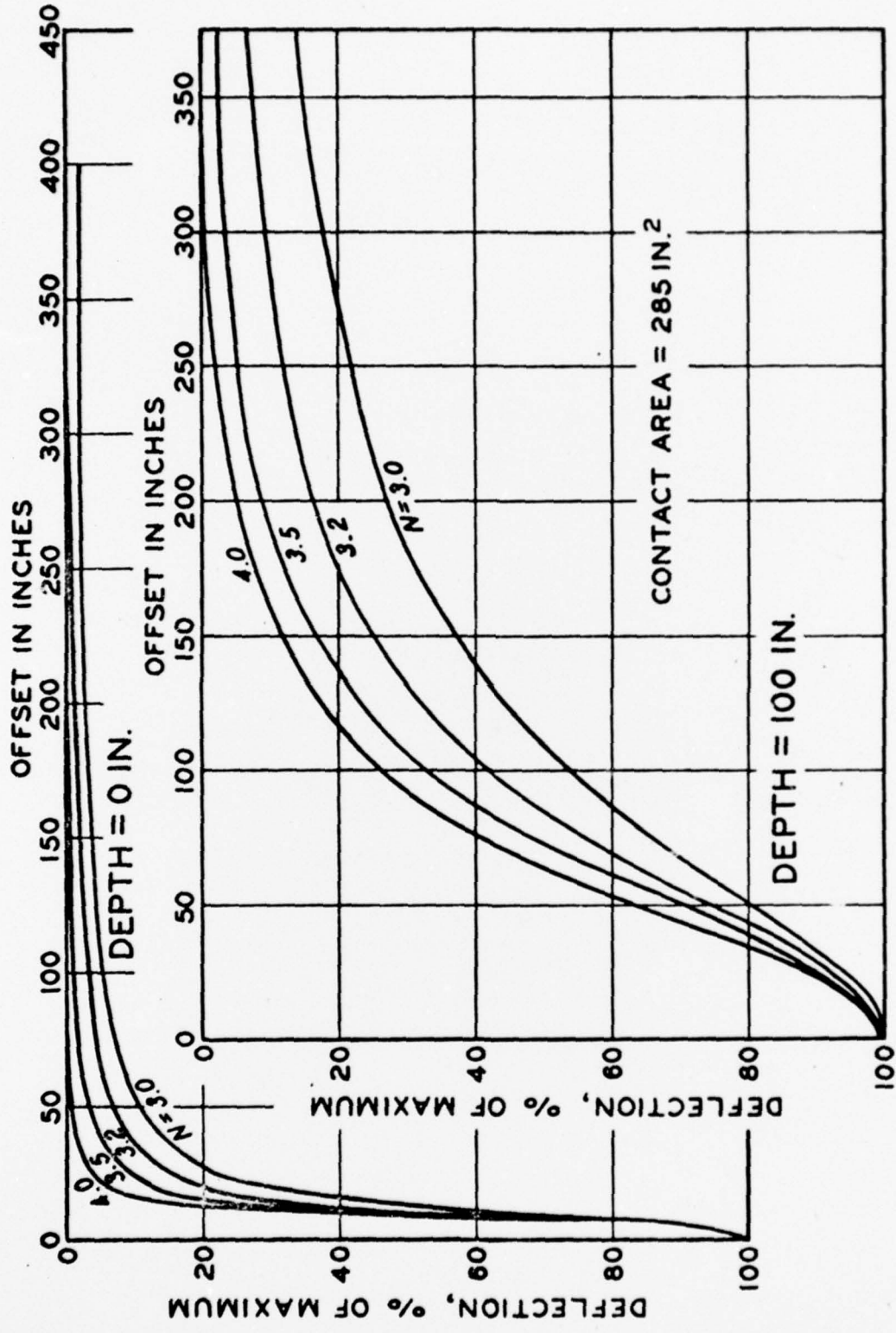

Fig. 5. Deflection Basins for Different Concentration Index

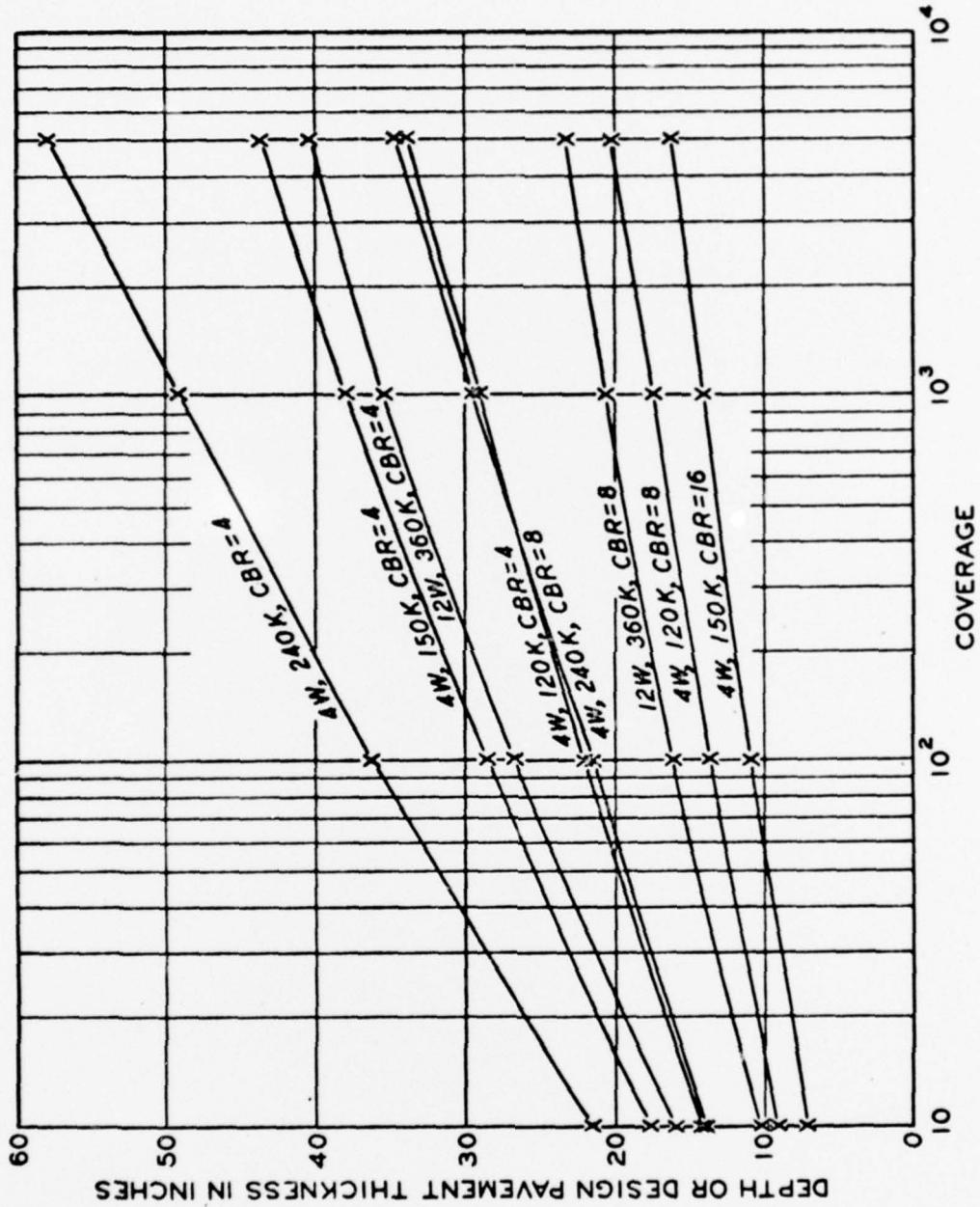

Fig. 6. Relations of Thickness and Coverage

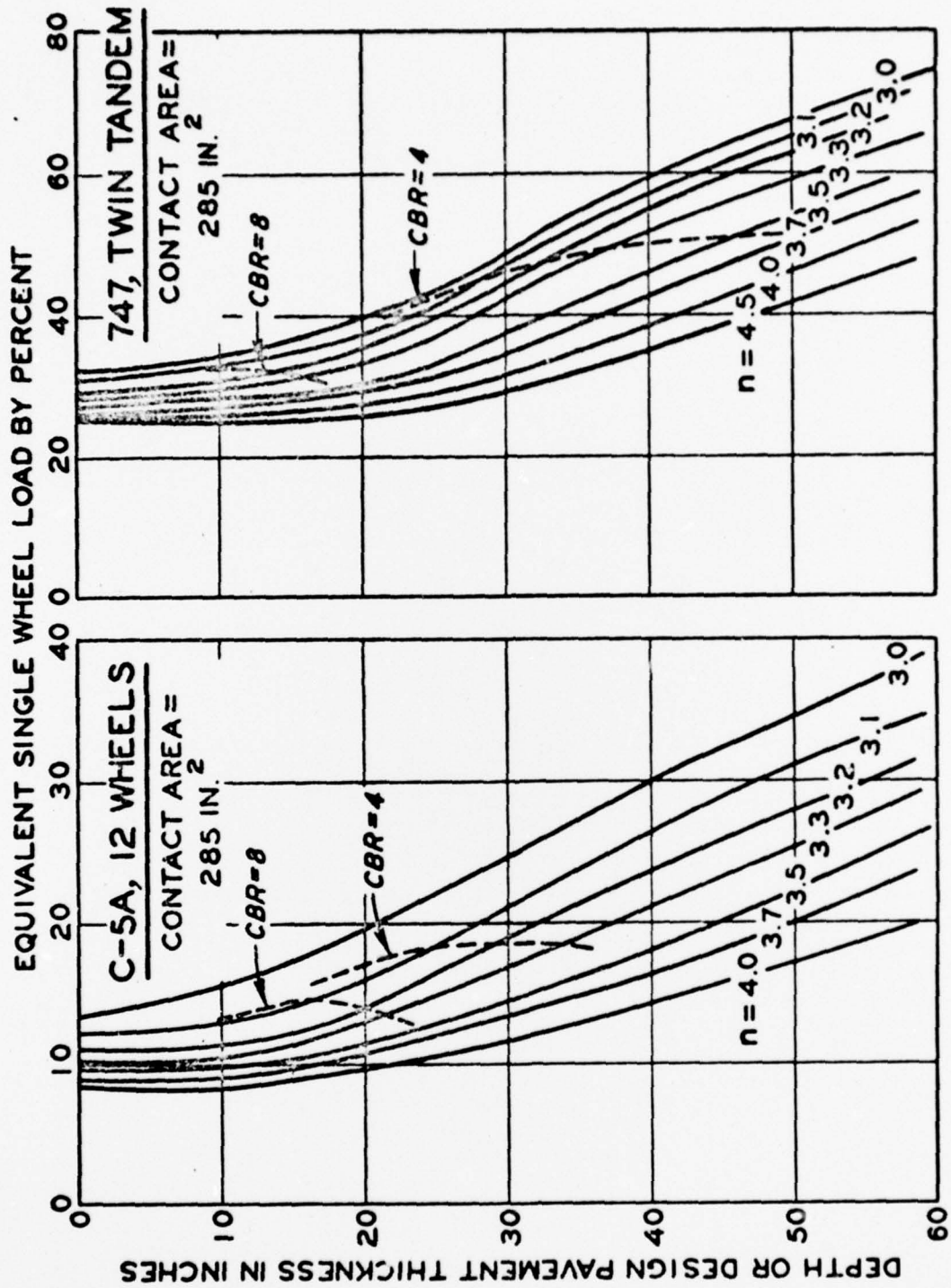

Fig. 7. Equivalent Single-Wheel Load Versus Depth at Different Concentration Indexes

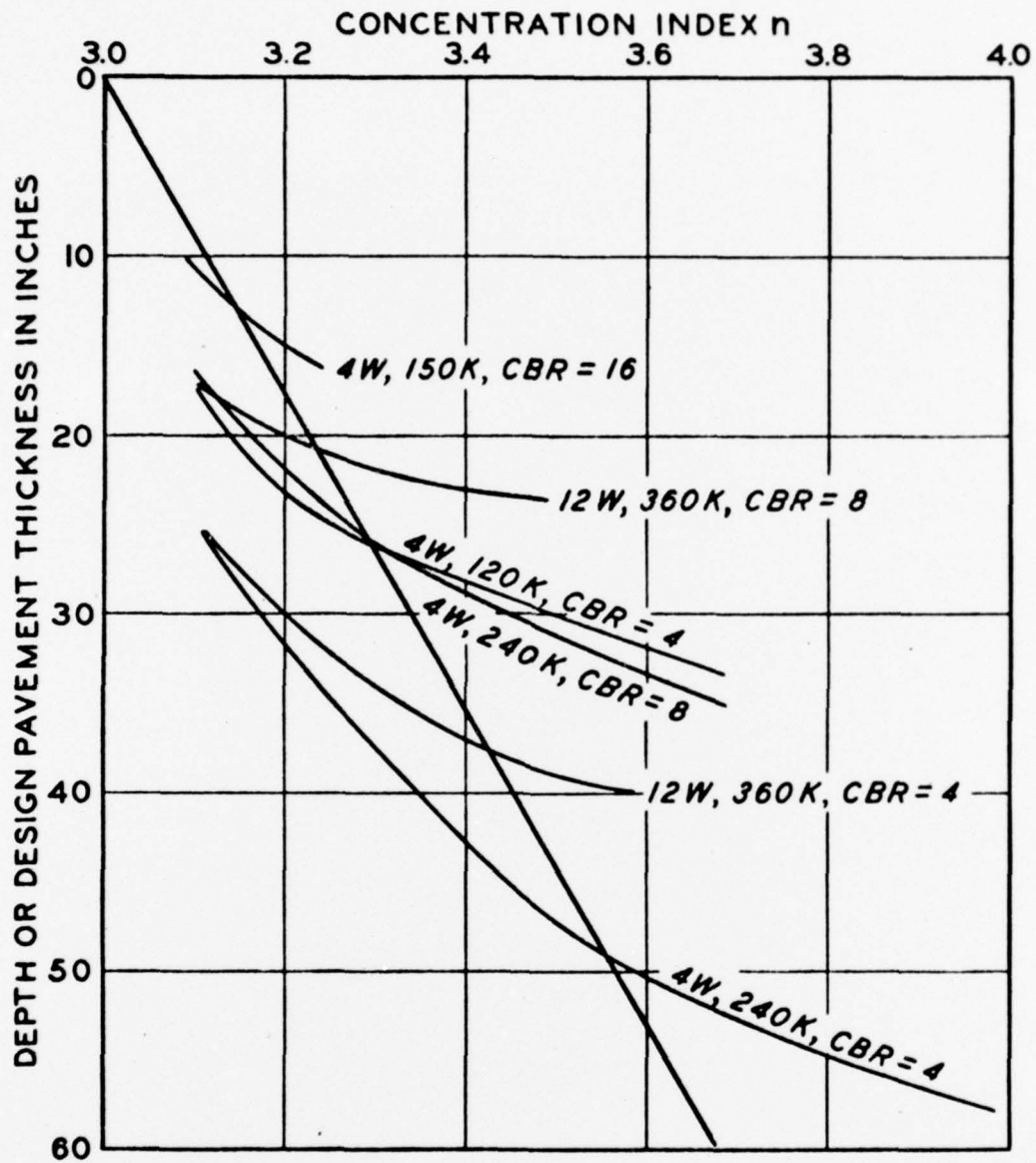

Fig. 8. Variations of Concentration Index with Parameters

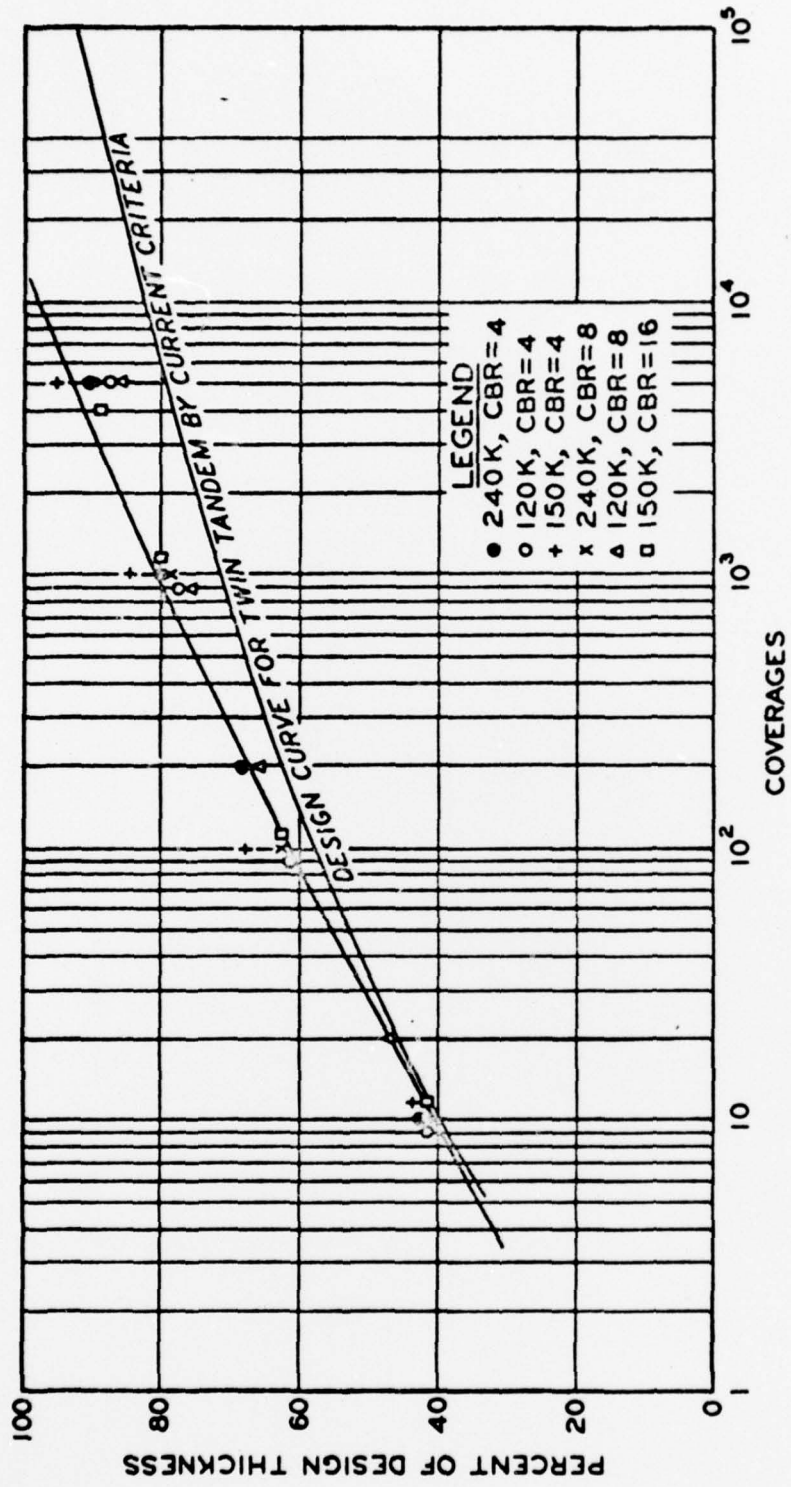

Fig. 9. Comparison of Results of Twin-Tandem Assembly Traffic Tests With Concentration Index

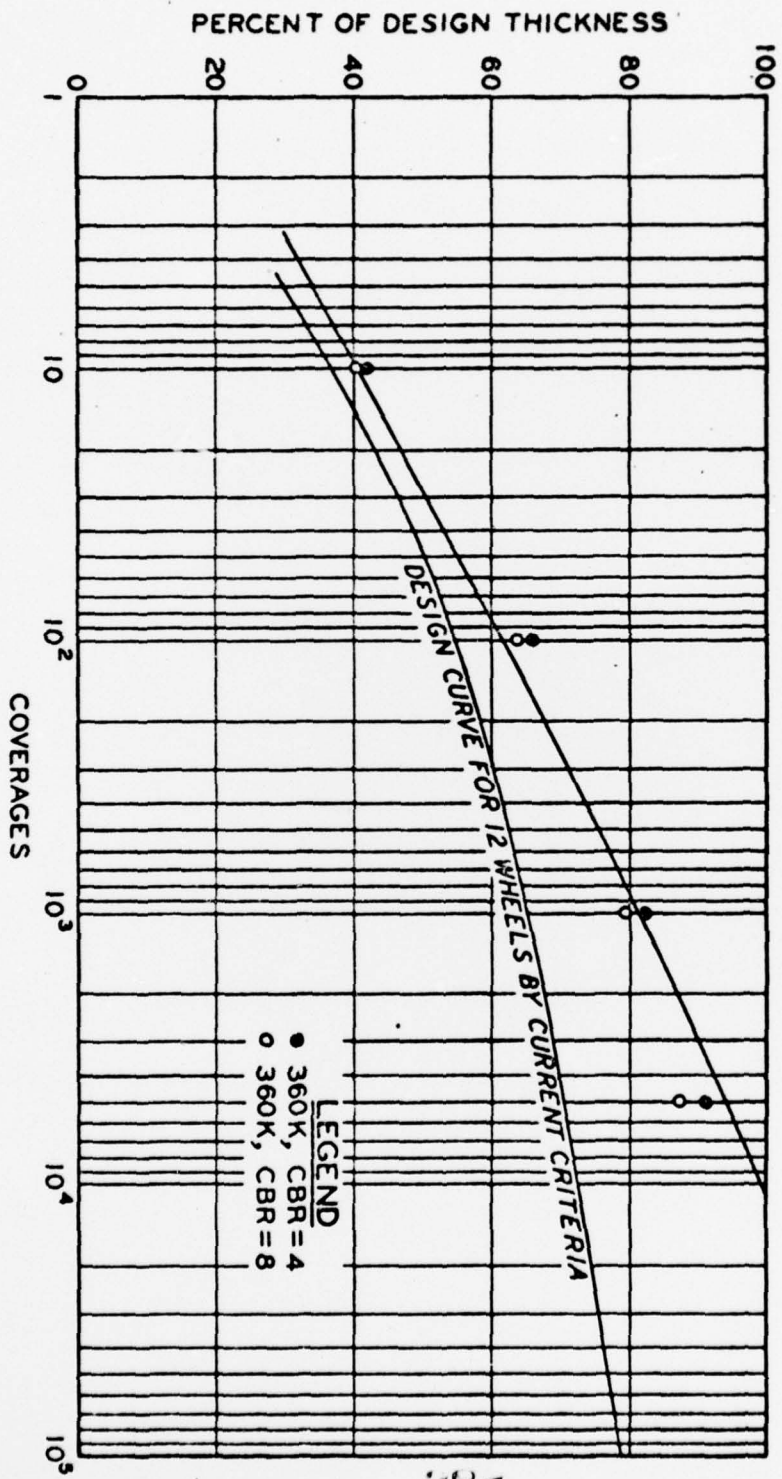

Fig. 10. Comparison of Results of 12-Wheel-Assembly Traffic Tests With Concentration Index

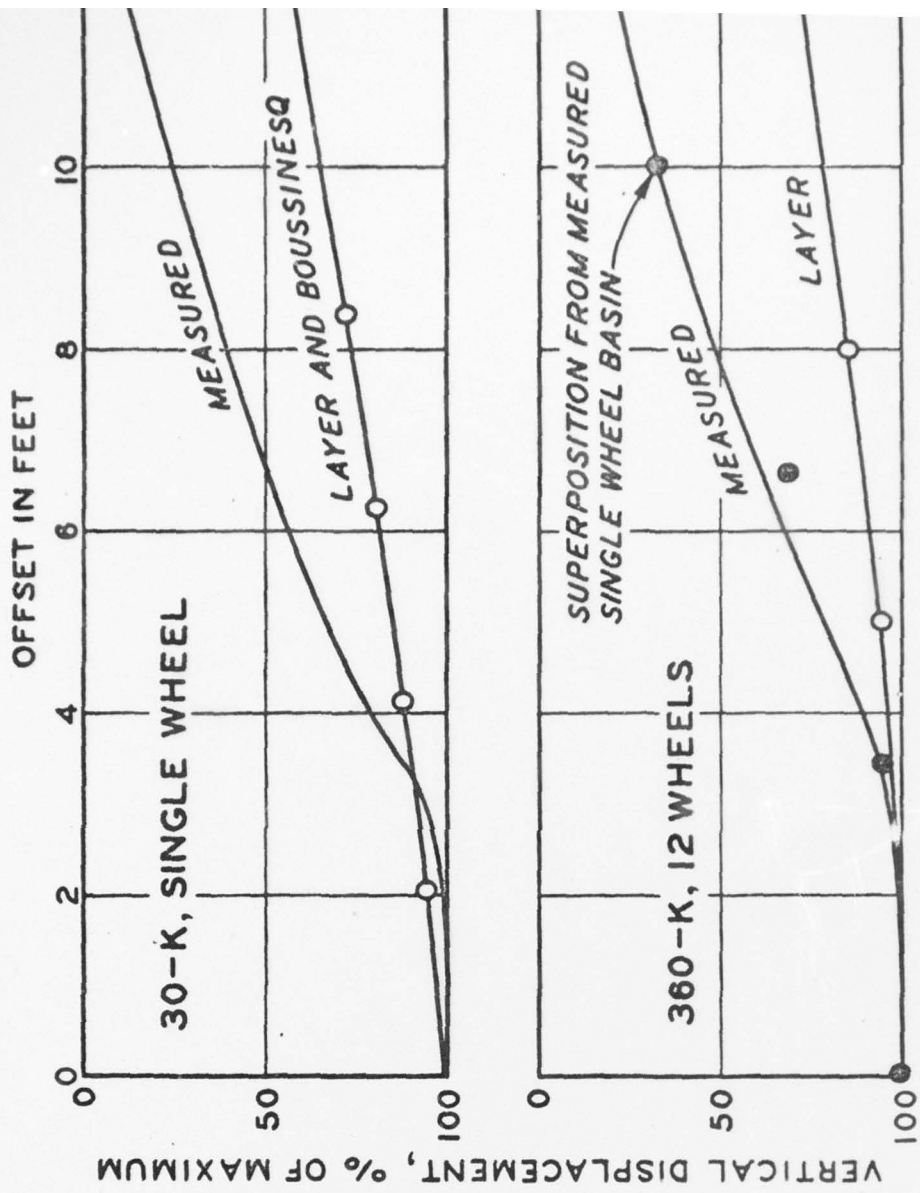

Fig. 1. Theoretical and Measured Deflection Basins for M_{HGL} Tests

