

AD-A036 561

SCIENCE APPLICATIONS INC SUNNYVALE CALIF  
DEVELOPMENT OF X-RAY DIAGNOSTICS FOR ADVANCED CONCEPTS SIMULATI--ETC(U)  
SEP 76 R B MOLER, J J LEPAGE, R I MILLER

F/G 18/4

DNA-001-73-C-0165

UNCLASSIFIED

SAI-76-517-SV

DNA-4104F

NL

1 OF 1  
AD-A  
036 561

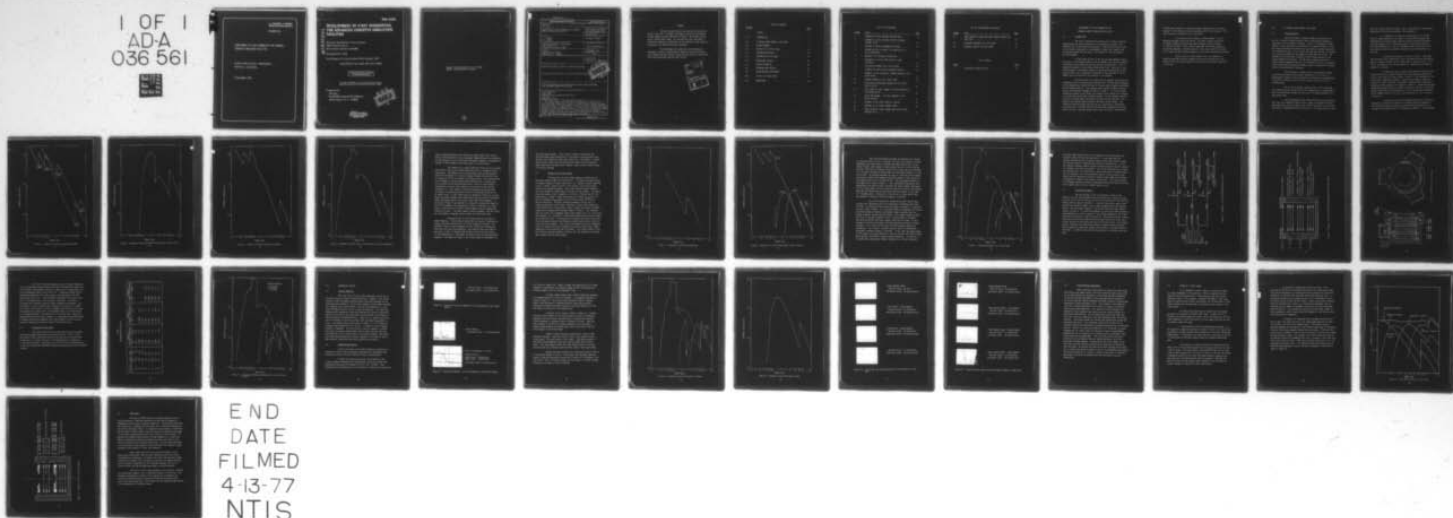

END  
DATE  
FILMED  
4-13-77  
NTIS

U.S. DEPARTMENT OF COMMERCE  
National Technical Information Service

AD-A036 561

DEVELOPMENT OF X-RAY DIAGNOSTICS FOR ADVANCED  
CONCEPTS SIMULATION FACILITIES

SCIENCE APPLICATIONS, INCORPORATED  
SUNNYVALE, CALIFORNIA

8 SEPTEMBER 1976

dc  
DNA 4104F

# DEVELOPMENT OF X-RAY DIAGNOSTICS FOR ADVANCED CONCEPTS SIMULATION FACILITIES

ADA 036561

Science Applications, Incorporated  
1257 Tasman Drive  
Sunnyvale, California 94086

8 September 1976

Final Report for Period May 1973—August 1974

CONTRACT No. DNA 001-73-C-0165

APPROVED FOR PUBLIC RELEASE;  
DISTRIBUTION UNLIMITED.

THIS WORK SPONSORED BY THE DEFENSE NUCLEAR AGENCY  
UNDER RDT&E RMSS CODE B324073464 W99QAXPF00121 H2590D.

Prepared for  
Director  
DEFENSE NUCLEAR AGENCY  
Washington, D. C. 20305

D D C  
REGISTERED  
MAR 9 1977  
C

REPRODUCED BY  
NATIONAL TECHNICAL  
INFORMATION SERVICE  
U. S. DEPARTMENT OF COMMERCE  
SPRINGFIELD, VA. 22161

Destroy this report when it is no longer  
needed. Do not return to sender.



UNCLASSIFIED

SECURITY CLASSIFICATION OF THIS PAGE (When Data Entered)

REPORT DOCUMENTATION PAGE		READ INSTRUCTIONS BEFORE COMPLETING FORM
1. REPORT NUMBER DNA 4104F	2. GOVT ACCESSION NO.	3. RECIPIENT'S CATALOG NUMBER
4. TITLE (and Subtitle) DEVELOPMENT OF X-RAY DIAGNOSTICS FOR ADVANCED CONCEPTS SIMULATION FACILITIES	5. TYPE OF REPORT & PERIOD COVERED Final Report for Period May 1973—August 1974	
	6. PERFORMING ORG. REPORT NUMBER SAI-76-517-SV	
7. AUTHOR(s) R. B. Moler J. J. LePage R. I. Miller	8. CONTRACT OR GRANT NUMBER(s) DNA 001-73-C-0165	
	10. PROGRAM ELEMENT, PROJECT, TASK AREA & WORK UNIT NUMBERS Subtask W99QAXPF001-21	
9. PERFORMING ORGANIZATION NAME AND ADDRESS Science Applications, Incorporated 1257 Tasman Drive Sunnyvale, California 94086	11. CONTROLLING OFFICE NAME AND ADDRESS Director Defense Nuclear Agency Washington, D.C. 20305	
	12. REPORT DATE 8 September 1976	
14. MONITORING AGENCY NAME & ADDRESS (if different from Controlling Office)	13. NUMBER OF PAGES 41	
	15. SECURITY CLASS (of this report) UNCLASSIFIED	
15a. DECLASSIFICATION/DOWNGRADING SCHEDULE		
16. DISTRIBUTION STATEMENT (of this Report) Approved for public release; distribution unlimited.		
17. DISTRIBUTION STATEMENT (of the abstract entered in Block 20, if different from Report)		
18. SUPPLEMENTARY NOTES This work sponsored by the Defense Nuclear Agency under RDT&E RMSS Code B324073464 W99QAXPF00121 H2590D.		
19. KEY WORDS (Continue on reverse side if necessary and identify by block number) X-ray Diagnostics X-ray Diode Advanced Concepts Simulation Facilities Rate Diode Stacked X-ray Diode		
20. ABSTRACT (Continue on reverse side if necessary and identify by block number) A stacked vacuum x-ray diode has been developed for application to Advanced Concept Simulation Facilities. A three channel diode was designed, built and tested. The three channels have 50 to 70 percent energy resolution with bands centered at approximately 1, 2.25 and 6.6 keV. Alternative channel designs are readily obtainable, as well as a rate diode to provide flat energy response from 1 to 20 keV. A pair of triple diodes would be capable of providing temporal and spectral resolution of the output of low energy simu- lation facilities in the energy range from 1 to 10 keV.		

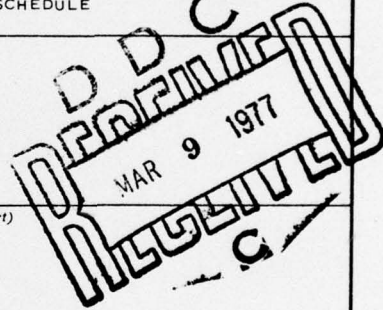

DD FORM 1473 EDITION OF 1 NOV 65 IS OBSOLETE

UNCLASSIFIED

SECURITY CLASSIFICATION OF THIS PAGE (When Data Entered)

PREFACE

The work reported herein was carried out during the period 1 May 1973 - 31 August 1974 under contract to the Defense Nuclear Agency (contract DNA 001-73-C-0165). The project monitor was Dr. Gordon Soper, RAEV. We conclude that this work marks a significant advance in capability for the analysis of the output of simulators, and should be pursued vigorously.

We acknowledge the cooperation and assistance of personnel at Physics International, especially Charles Stallings, Lazlo Demeter and Kurt Nielsen, which made the practical testing of the triple diode both possible and fruitful.

ACCESSION No.	White Section <input checked="" type="checkbox"/>
NTIS	Buff Section <input type="checkbox"/>
D.C.	
UNANNOUNCED	
JUSTIFICATION	
BY	DISTRIBUTION/AVAILABILITY CODES
Dist.	AVAIL. and/or SPECIAL
A	

TABLE OF CONTENTS

<u>SECTION</u>		<u>PAGE</u>
	PREFACE . . . . .	1
1.0	INTRODUCTION. . . . .	5
2.0	A STACKED THREE-CHANNEL X-RAY DIODE . . . . .	7
2.1	DESIGN APPROACH . . . . .	7
2.2	DESIGN OF THE TRIPLE DIODE. . . . .	14
2.3	CONSTRUCTION DETAILS. . . . .	19
2.4	CALIBRATION OF THE DIODE. . . . .	23
3.0	OPERATIONAL RESULTS . . . . .	26
3.1	INITIAL OPERATION . . . . .	26
3.2	EXPLODING WIRE RESULTS. . . . .	26
3.3	PLASMA HEATING EXPERIMENTS. . . . .	33
4.0	DESIGN OF A "RATE DIODE". . . . .	34
5.0	CONCLUSION. . . . .	38

## LIST OF ILLUSTRATIONS

<u>FIGURE</u>	<u>TITLE</u>	<u>PAGE</u>
1	RESPONSE OF NICKEL AND GOLD CATHODE XRD'S. . . . .	9
2	RESPONSE OF NICKEL CATHODE XRD WITH CHLORINE (SARAN) FILTER . . . . .	10
3	RESPONSE OF NICKEL ON MAGNESIUM CATHODE. . . . .	11
4	RESPONSE OF XRD OF FIGURE 3 FILTERED WITH 0.31 mg/cm <sup>2</sup> MAGNESIUM . . . . .	12
5	RESPONSE OF A PALLADIUM CATHODE XRD. . . . .	15
6	RESPONSE OF A TRIPLE DIODE WITHOUT K-EDGE FILTERING. . . . .	16
7	CALCULATED RESPONSE FOR A TRIPLE DIODE . . . . .	18
8	SCHEMATIC OF TRIPLE DIODE RECORDING CIRCUIT. . . .	20
9	SCHEMATIC OF THE INDIVIDUAL ELEMENTS MAKING UP THE TRIPLE DIODE . . . . .	21
10	ASSEMBLY DRAWING OF THE TRIPLE DIODE . . . . .	22
11	CALCULATED AND MEASURED RESPONSE FOR THE TRIPLE DIODE AS BUILT . . . . .	25
12	PULSE FROM THE FIRST CHANNEL OF TRIDI GENERATED BY THE PLASMA SWITCH. . . . .	27
13	PULSE FROM CHANNEL 1 OF TRIDI COMPARED TO THE SWITCH VOLTAGE . . . . .	27
14	RESPONSE OF THE TRIPLE DIODE AS FIELDDED. . . . .	29
15	RESPONSE OF THE SINGLE CHANNEL DIODE . . . . .	30
16	TRACES FROM THE SINGLE CHANNEL AND TRIPLE DIODES FOR SHOT 1214. . . . .	31

LIST OF ILLUSTRATIONS (Continued)

<u>FIGURE</u>	<u>TITLE</u>	<u>PAGE</u>
17	TRACES FROM THE SINGLE AND THREE CHANNEL DIODES FOR SHOT 1204 . . . . .	32
18	CALCULATED RESPONSE OF A FLAT DIODE . . . . .	36
19	SCHEMATIC PLAN OF THE FLAT DIODE. . . . .	37

LIST OF TABLES

<u>TABLE</u>		<u>PAGE</u>
1	CALORIMETER CHARACTERISTICS . . . . .	24

DEVELOPMENT OF X-RAY DIAGNOSTICS FOR  
ADVANCED CONCEPTS SIMULATION FACILITIES

1.0 INTRODUCTION

The use of simulation facilities such as those at Physics International and other organizations is beginning to assume a more important role in the testing of materials. These facilities will take on even greater importance as developments improve their capabilities to the point where they may play a role parallel to the underground test environment.

A significant barrier to the use and development of these facilities is the present general lack of adequate time resolved spectral information of the output of the many machine configurations. This is especially apparent in the energy regime below 5 keV. There are a very limited number of techniques capable of performing spectroscopy in this region at the x-ray intensities encountered in the simulators, and the number that can resolve the time history is yet smaller.

The SAI vacuum x-ray diode XRD can provide limited spectral information with a sub-nanosecond response time. The XRD takes advantage of the photoelectric effect and has an inherent energy response determined by the cathode material. The response versus energy of XRD's with gold, nickel, and aluminum cathodes are shown in Figure 1. By filtering the radiation incident on the diode, the response can be shaped to be peaked in a relatively narrow band of photon energy. For the response function of such a filtered diode, the energy resolution may be defined as the width of the response band divided by the mean in-band energy. The following discussion deals with the design, construction, calibration and testing of a 3 channel XRD and the operational experience achieved with it on OWL II and the plasma switch device at Physics International.

A diode whose response is relatively energy independent in the energy range of 1 to 20 keV has also been designed and will be discussed. This type of diode is referred to as a rate diode.

As a result of this project, a three channel, in-line diode was designed, built and tested. The three channels have 50 to 70 percent energy resolution with bands centered at approximately 1, 2.25 and 6.6 keV. Early concerns about EMP interference proved to be largely unfounded. Minimum signal to noise levels were of the order of 8:1 even with the diodes preceded by a 25 percent transmitting screen.

Using a pair of triple diodes (i.e., six channels) it should be possible to obtain temporal and spectral resolution of the output of the low energy simulation facilities in the energy range from 1 to 10 keV.

## 2.0 A STACKED THREE-CHANNEL X-RAY DIODE

### 2.1 Design Approach.

The single channel response diodes constructed by SAI for use in the UGT program achieve a narrow energy band response by using the filter fluorescer technique. This is a conceptually simple method in which the spectrum of interest first passes through a filter foil which preferentially transmits a pass band of energies just below its K absorption edge. This filtered spectrum then excites a fluorescer foil having an absorption edge lower in energy than the filter. The combined filter-fluorescer response is thus strongly peaked in the region between the two edges. The XRD, whose response also has a strong energy dependence, detects the fluorescence as well as scattered radiation and further reduces extraneous signal through post filtering and its own characteristic response.

This technique is useful above 1.3 keV however because of the low efficiency of the process (typically  $10^{-4}$  or less). A semiconductor detector, with a sensitivity of about 0.25 coulombs/joule is desirable instead of the XRD, with a typical sensitivity of  $10^{-5}$  coulombs/joule.

The Air Force Weapons Laboratory has in fact exploited this technique using the Ross filter pair method which is equivalent to the filter-fluorescer method but uses a pair of matched detectors for each energy band.

The disadvantage of the filter-fluorescer and particularly the filter pair method is that to have a number of channels involves a large beam area, since in general each filter-fluorescer or each filter must have an unobstructed view of the source. In either case the lowest

practical energy response is about 1 keV, a consequence of the inherent properties of silicon semiconductor x-ray detectors.

It appeared to us that the characteristics of the XRD could be taken advantage of to produce a narrow energy response and furthermore two or more diodes could be stacked one behind the other, with the elements of one diode being used to tailor the response of the diode following it. Such an arrangement would occupy very little area and would have the excellent reliability and reproducibility of the XRD.

A typical XRD response is shown in Figure 1. Note that the efficiency falls monotonically until the energy of the K absorption edge is reached, at which point a sharp jump in response occurs. If a filter is placed in front of the detector a response such as shown in Figure 2 is achieved.

A diode which has a response with greater selectivity can be made by using a suitable substrate for the cathode and depositing on it a thin layer of nickel or gold. Figure 3 is the response of a Ni diode using a magnesium substrate. Note that the edge at 1.255 keV results in a sharp reduction in response. Combining this diode with a magnesium filter produces the response of Figure 4. Diodes and filtered diodes having characteristics similar to those of Figures 1-4 have been designed and built by SAI personnel for use in various UGT experiments and it seemed probable that they could be adapted for use on simulator diagnostics.

In order to test this proposition explicitly it would be necessary to compute the response of a stacked diode to determine if the individual channels would have sufficiently high sensitivity to respond in the expected flux of a diagnostic simulator. It was decided

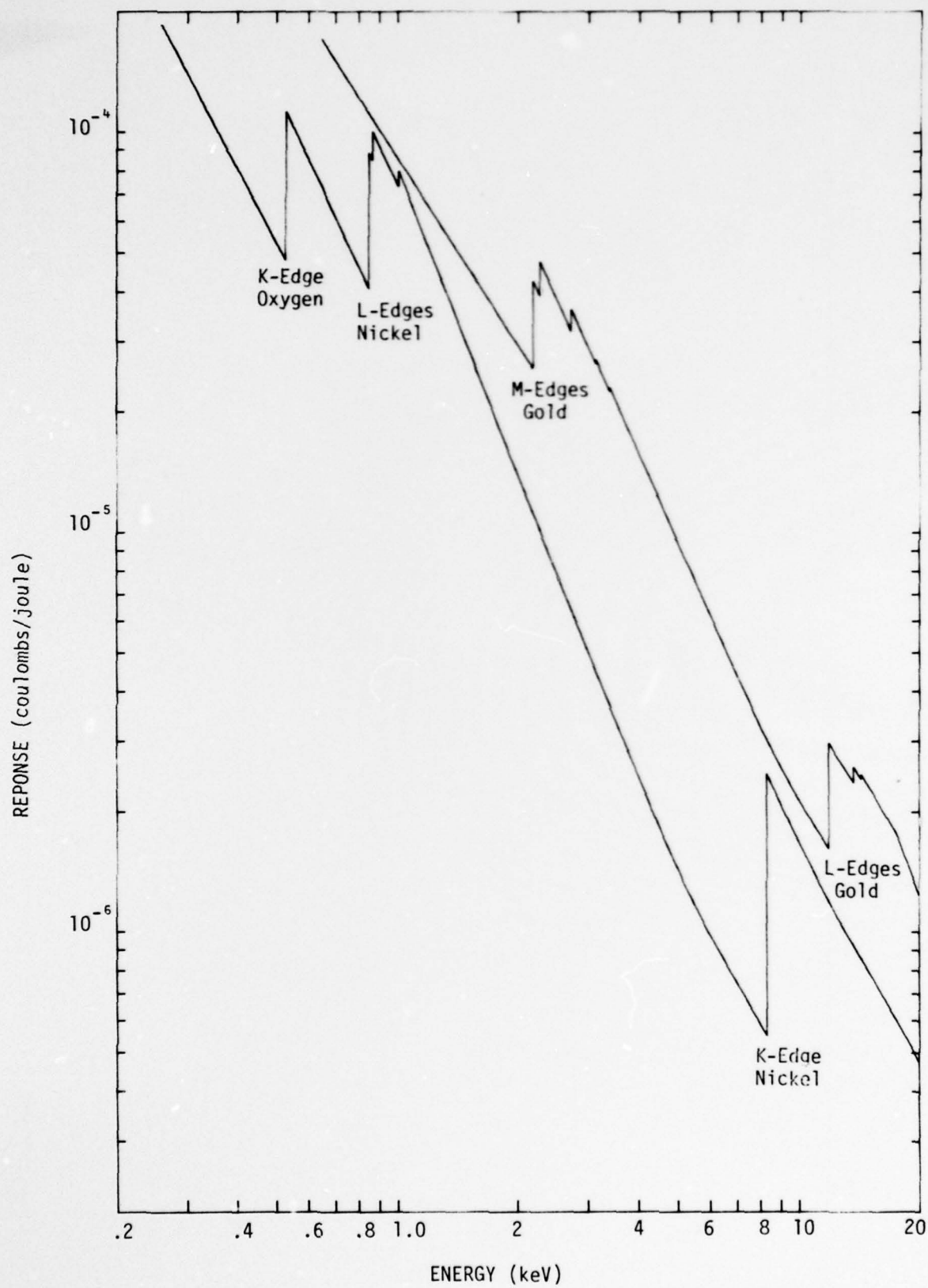

Figure 1. Response of Nickel and Gold Cathode XRD's.

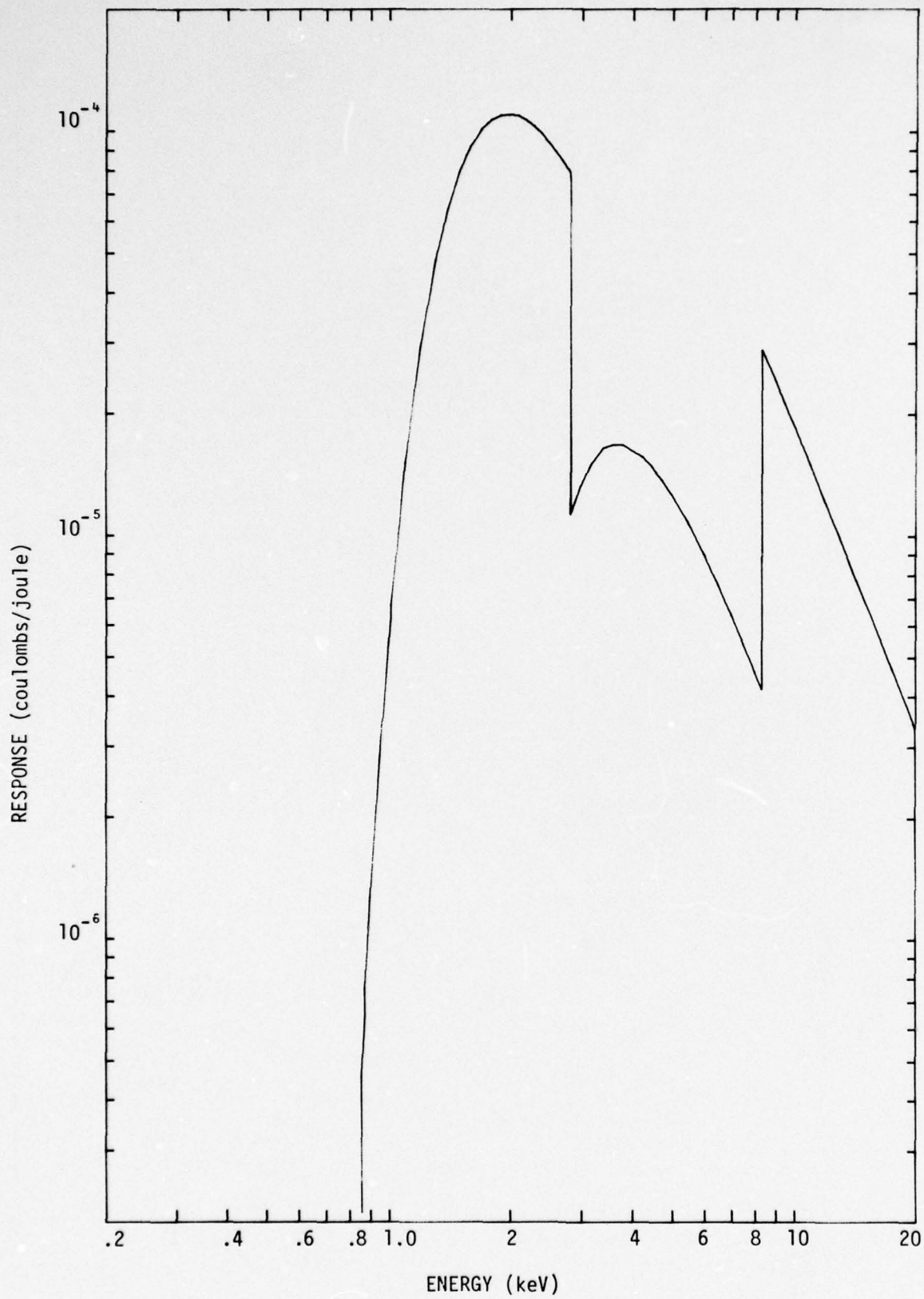

Figure 2. Response of Nickel Cathode XRD With Chlorine (Saran) Filter.

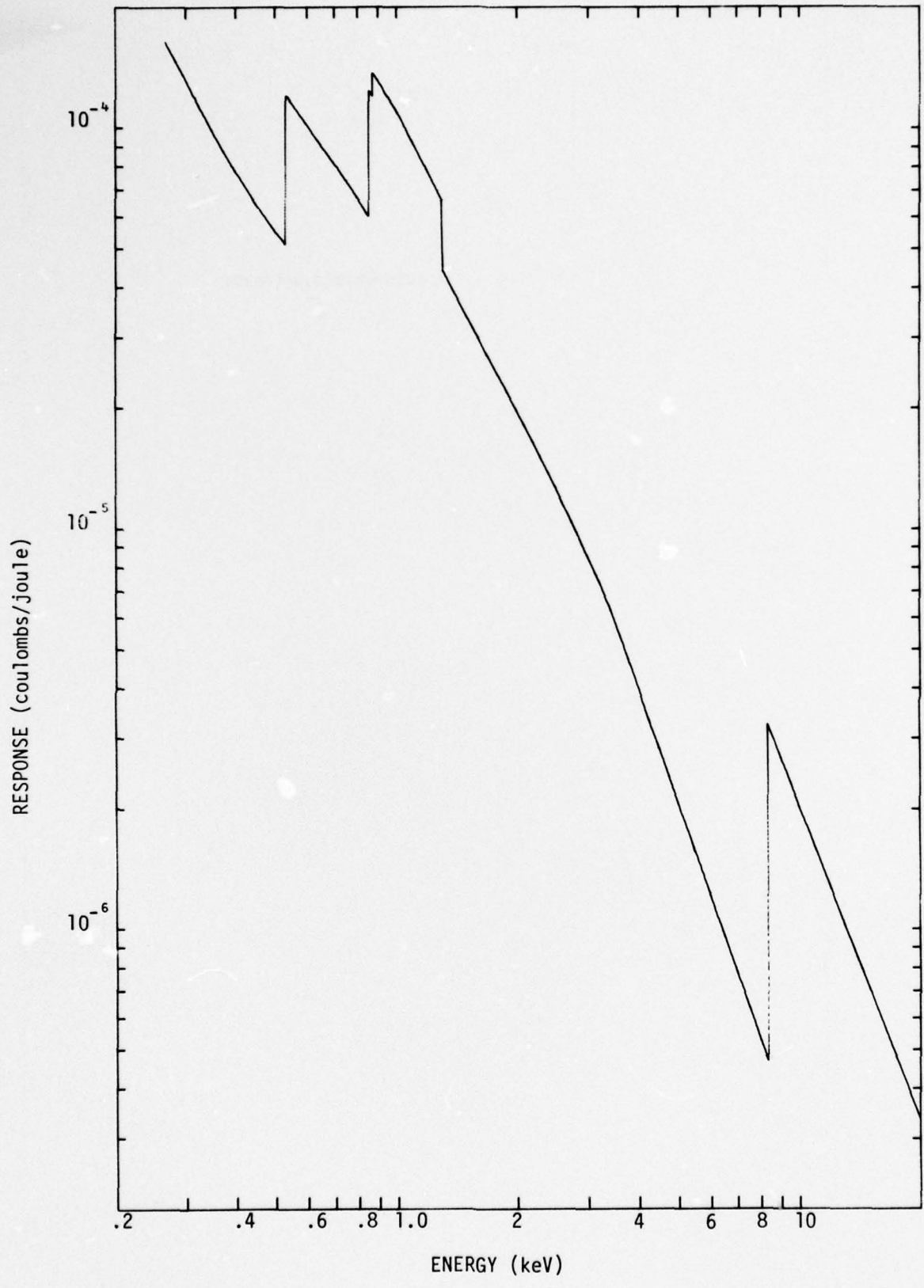

Figure 3. Response of Nickel on Magnesium Cathode.

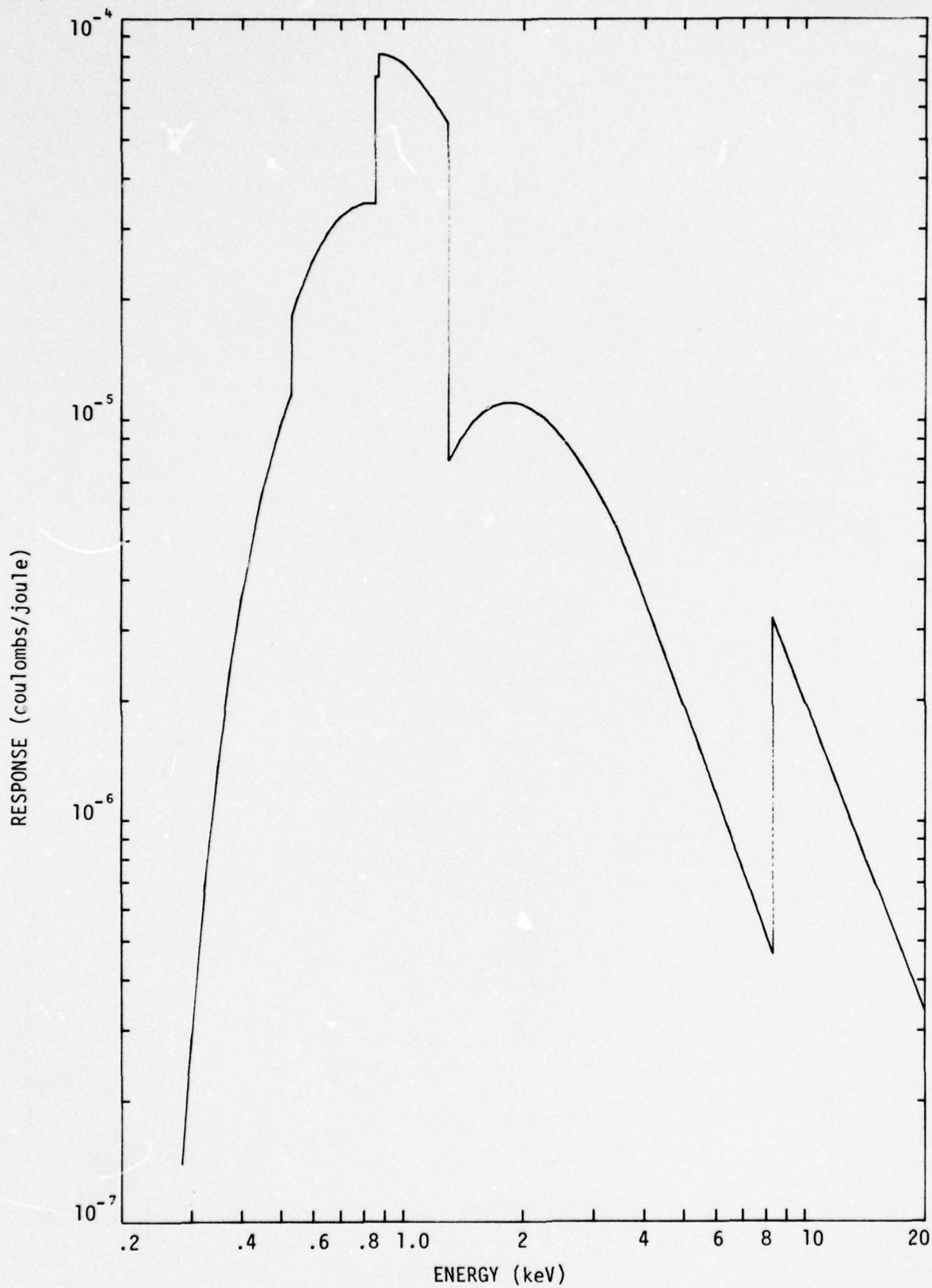

Figure 4. Response of XRD of Figure 3 Filtered With  $0.31 \text{ mg/cm}^2$  Magnesium.

that a stacked 3-channel unit covering an energy range from 1 keV to about 12 keV would be not only an adequate demonstration of the potential of such diodes, but also a practical and useful diagnostic instrument for the OWL II device where initial tests were to be carried out.

The response of a single diode and filter can be calculated with relative ease, but a second diode and filter is necessarily more complicated. The complexity of the calculation and its magnitude dictated the development of a special computer program which would allow the change of filters and diodes with relative ease. This program makes use of elements of other programs where possible but is largely new. It calculates the new spectrum each time a filter or diode element is encountered, as well as the response of each diode to the spectrum incident on it. Even though a restricted energy range was involved, the number of energy points which had to be considered turned out to be rather large. In the simple case of a magnesium filter and a nickel diode, one would encounter two K-absorption edges and three L-absorption edges (two energy points each) and at least four diode elements. In the actual program it was decided to include the K-absorption edges for most of the elements from magnesium to nickel (1.305 keV to 8.3 keV), since it was difficult to predict which elements might be appropriate choices as filters. The total number of points between 1 keV and 10 keV was 22 although a somewhat smaller number could have been used.

A necessary part of this program was the inclusion of diode responses. Since diodes are made with a variety of cathodes and anodes, the actual construction of a given diode was required. The available files of diode responses did not include this information, hence new files had to be generated. We wished to keep the number of new files as small as possible and decided to base the triple diode on the combination of a few diodes of proven design, having predictable response. The diodes of Figures 1 and 3 were chosen as candidates for

the low energy channels. Since it was virtually certain that the available power would decrease with x-ray energy, the second and third channels were required to have high sensitivity. Accordingly, a highly sensitive gold diode and a palladium diode (Figure 5) were included. Other diodes were included later; however, these initial choices proved to be nearly optimum.

## 2.2 Design of the Triple Diode.

The design of the triple diode began by considering the desirable channel widths and sensitivities. In general one would prefer to achieve channels of equal resolution, i.e., channels spaced logarithmically in energy, because typically the spectral intensity decreases rapidly with increasing energy. Thus logarithmically spaced channels will each respond to roughly equal fractions of the fluence. This would place the center of the 3 channels at 1.57 keV, 3.395 keV and 7.32 keV respectively. Channel 1 would then require a silicon ( $K_{\text{abs}}$ -edge 1.84 keV) or phosphorus ( $K_{\text{abs}}$ -edge 2.14 keV) filter neither of which is entirely practical. The best compromise seemed to be the use of a magnesium substrate nickel diode. Choosing a nickel second diode and a gold third diode, filtered with 3 mg/cm<sup>2</sup> carbon and 3 mg/cm<sup>2</sup> aluminum, respectively, produced the responses shown in Figure 6. We concluded that this result was inadequate because the channels were not sufficiently well defined, i.e. the width of each channel determined by the half power points were too wide. It was desired to increase the selectivity of the first and second channels significantly without decreasing the sensitivity of the third channel. This could be achieved by placing a magnesium filter in front of the first diode and by placing an additional K-edge absorption filter following the first diode. This second channel filter was initially scandium (K-edge 4.49 keV), but this produced an unacceptable response for the third channel.

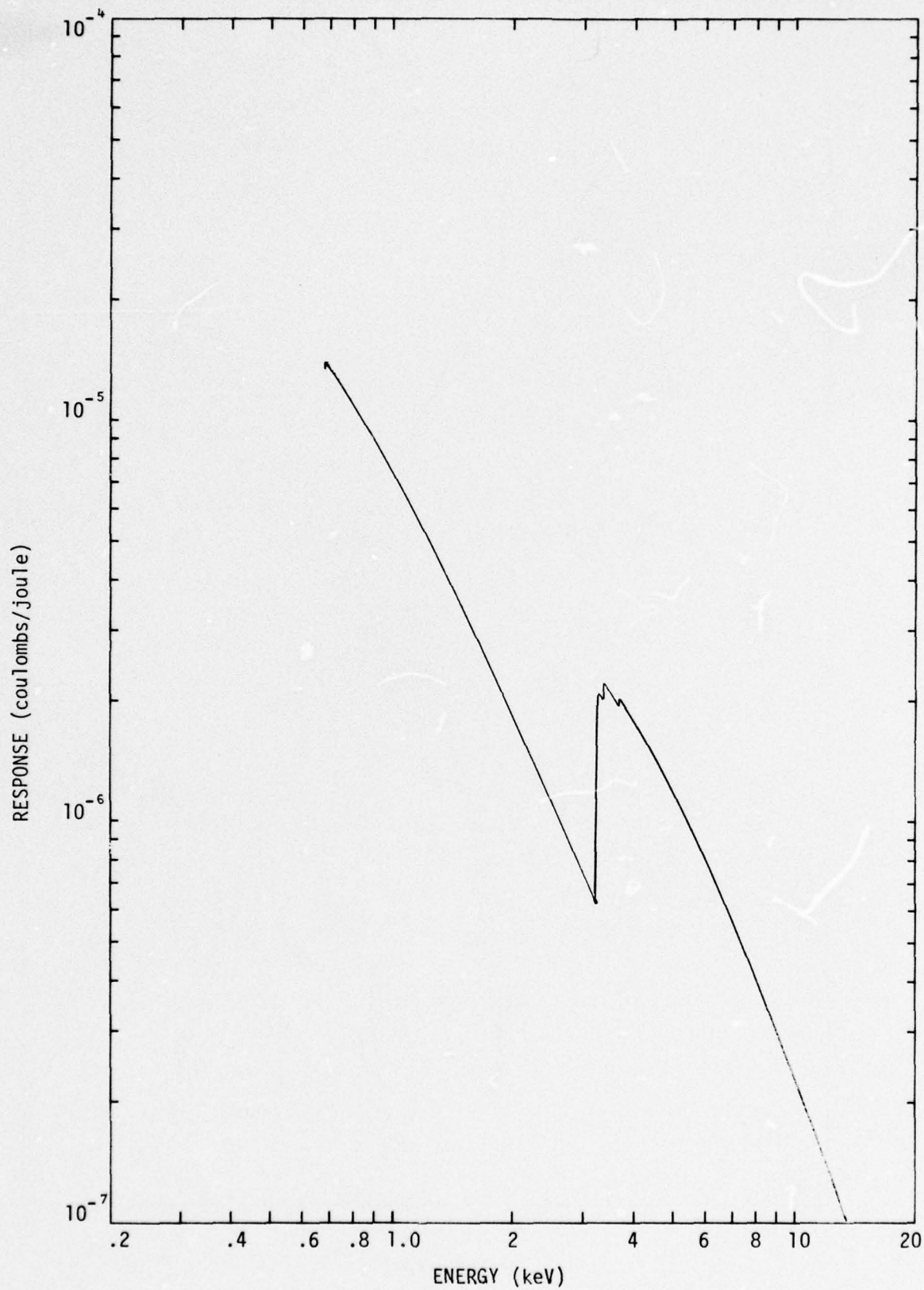

Figure 5. Response of a Palladium Cathode XRD.

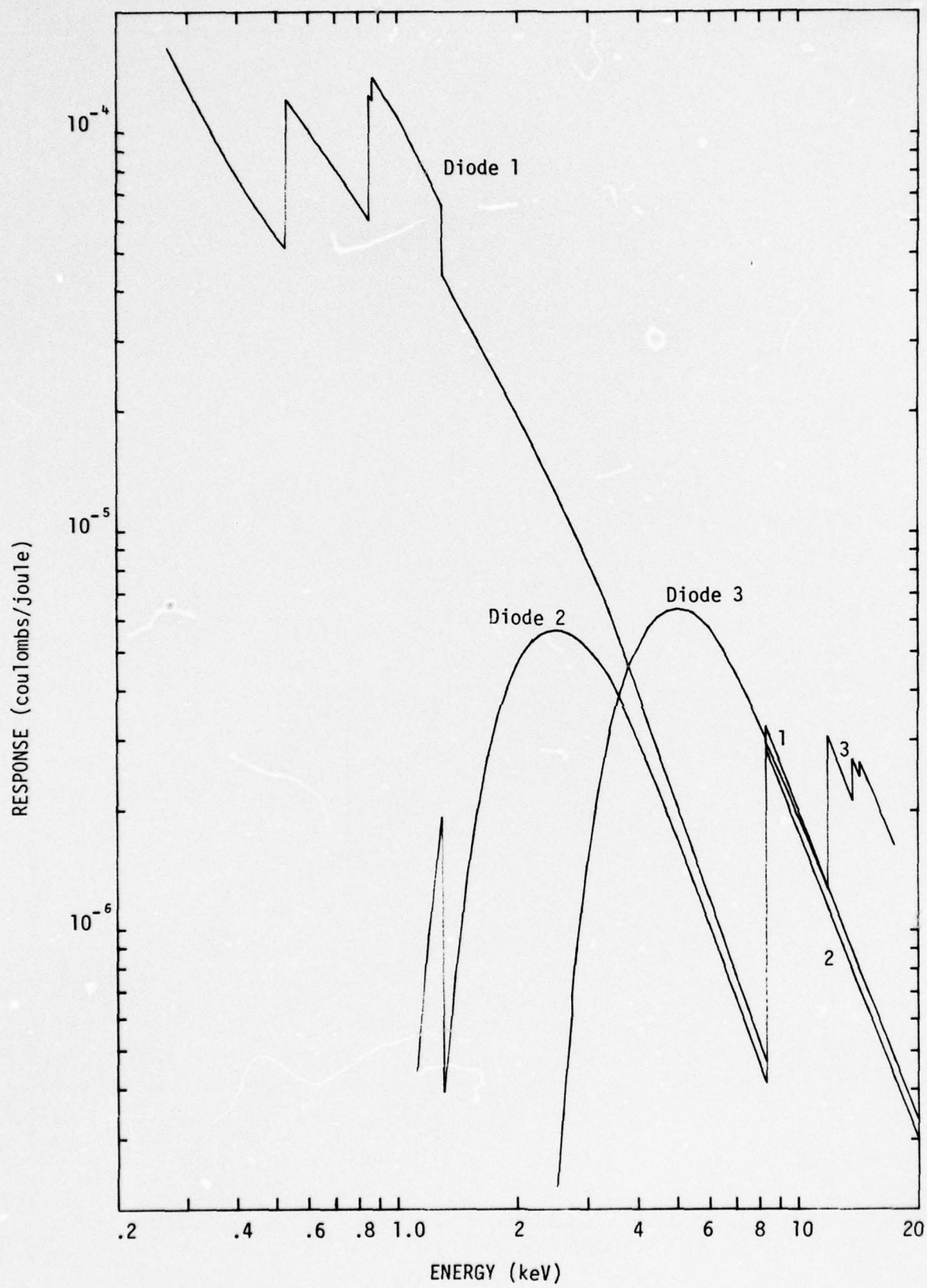

Figure 6. Response of a Triple Diode Without K-edge Filtering.

Since the thicknesses and types of materials are limited for energies below 4.5 keV, a chlorine foil with its K-edge at 2.83 keV appeared to be a good choice to define the upper energy limit of the second channel, even though a slightly wider band (1.3 to 4.5 keV) was desired. The choice of chlorine proved to be a good one and a thickness of  $\sim 3.6 \text{ mg/cm}^2$  provided an energy band with half power points at 1.8 keV and 3.0 keV. An aluminum absorber was used to tailor the third channel to provide a rather broad channel centered at about 6.5 keV, having its half power points at 5.2 keV and 9.8 keV. The calculated response for the composite is shown in Figure 7. This calculated response was only approximate since actual filter thickness and diode element thicknesses for the triple diode, as built, would be used for the final calculations. Note that the sensitivity of the second and third diodes is less than  $10^{-5}$  coulombs/joule. Although this sensitivity is lower than we had anticipated, it proved to be quite adequate in practice.

One of the conclusions reached during this design phase concerns the limitations which are encountered in designing this type of diode. We discovered that within any decade of energy it is possible to have at most 3 diodes. If a 4-channel diode is attempted, the filters and diode elements interfere and produce channel responses that are highly irregular and have multiple peaks. Such channels would be quite difficult to use and in general, with a limited number of channels, the spectrum derived from such channels would not be unique. It was pointed out earlier that simple filtering produced too broad a channel response. It is fairly obvious that the ideal channel response is rectangular. For a multiple channel system a series of overlapping rectangular response channels is desired. If the lower and upper bounds of the channel are poorly defined, as was the case for the initial triple diode designs, the derived spectrum becomes ambiguous. In contrast to the essentially rectangular channel response for a filter-fluorescer,

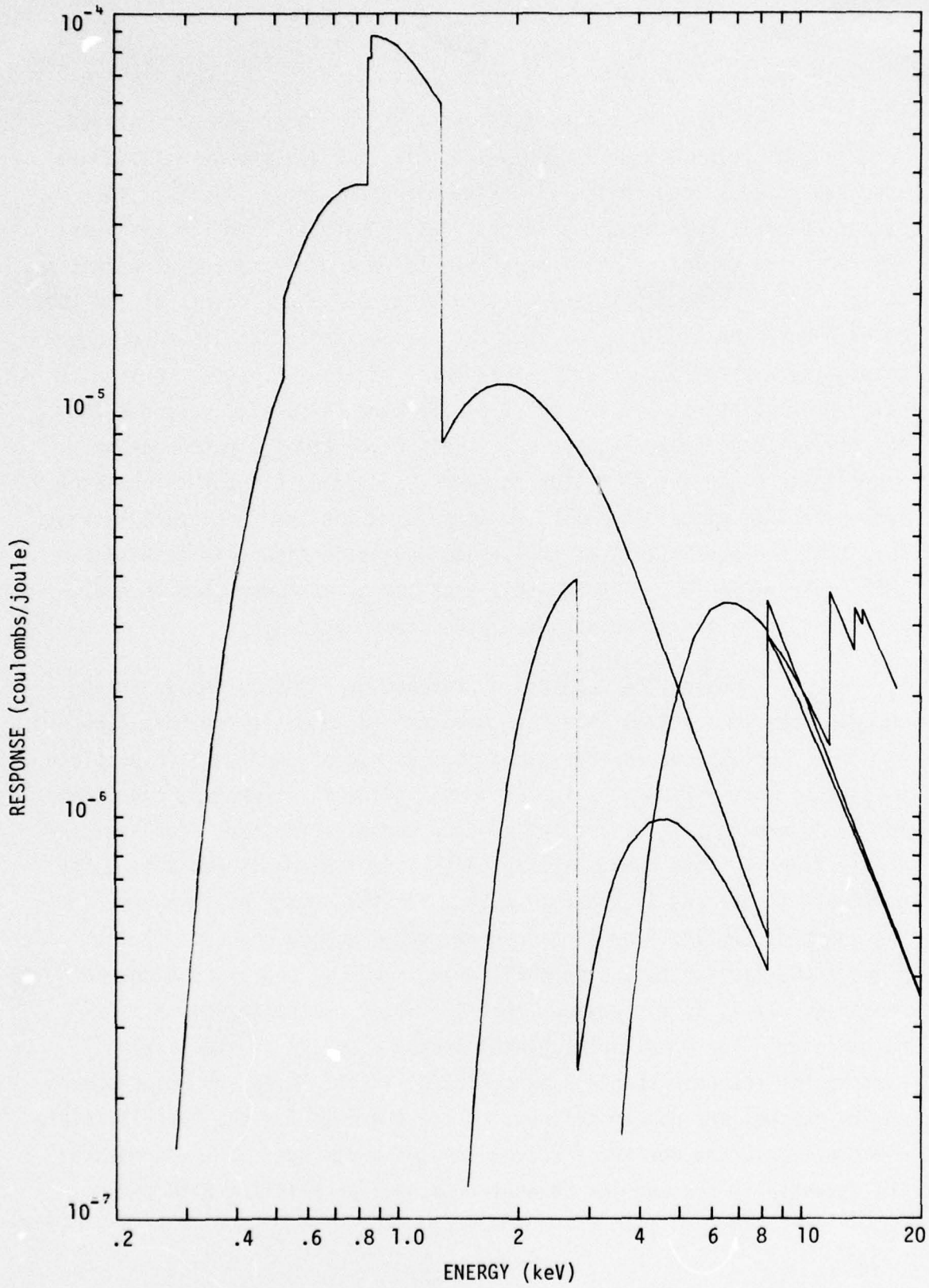

Figure 7. Calculated Response for a Triple Diode.

4  
only the higher energy limit of each channel in the triple diode can be made to have the desired sharp cutoff. It was found that the channel response must be relatively narrow to make each channel unique. This had the effect of sampling the spectrum at three points. In the UGT program, adjacent channel overlap insures that every spectral feature is included in at least one channel. The triple diode does not include this feature, and it is possible for there to be spectral features which are not recorded. This non-overlapping feature of the present triple diode could be remedied by building a second triple diode with channels intermediate to those of the present triple diode. This would provide 6 overlapping channels and would unambiguously define the energy spectrum from slightly below 1 keV to slightly above 10 keV.

### 2.3 Construction Details

The construction of the triple diode is based on the design of the SAI XRD and MXRD which has evolved over a period of eight years of use in the UGT program, and was first described in the MINT LEAF Project Officers Report POR 6415-1. A special housing was made to hold the multiple element assembly, and to make connection with the separate diodes. The individual elements of the triple diode are shown schematically in Figure 8. A simplified schematic of the triple diode recording instrumentation is given in Figure 9. An assembly drawing of the triple diode and its housing is shown in Figure 10. The housing and the internal structure of the triple diode had been designed before the diodes themselves, and did not anticipate the use of the first filter. An available plastic insulator ring which mates with the standard diode housing was used to mount this additional element and to mount a collimator ahead of the diode. In order to mate these two assemblies an aluminum spacer was built.

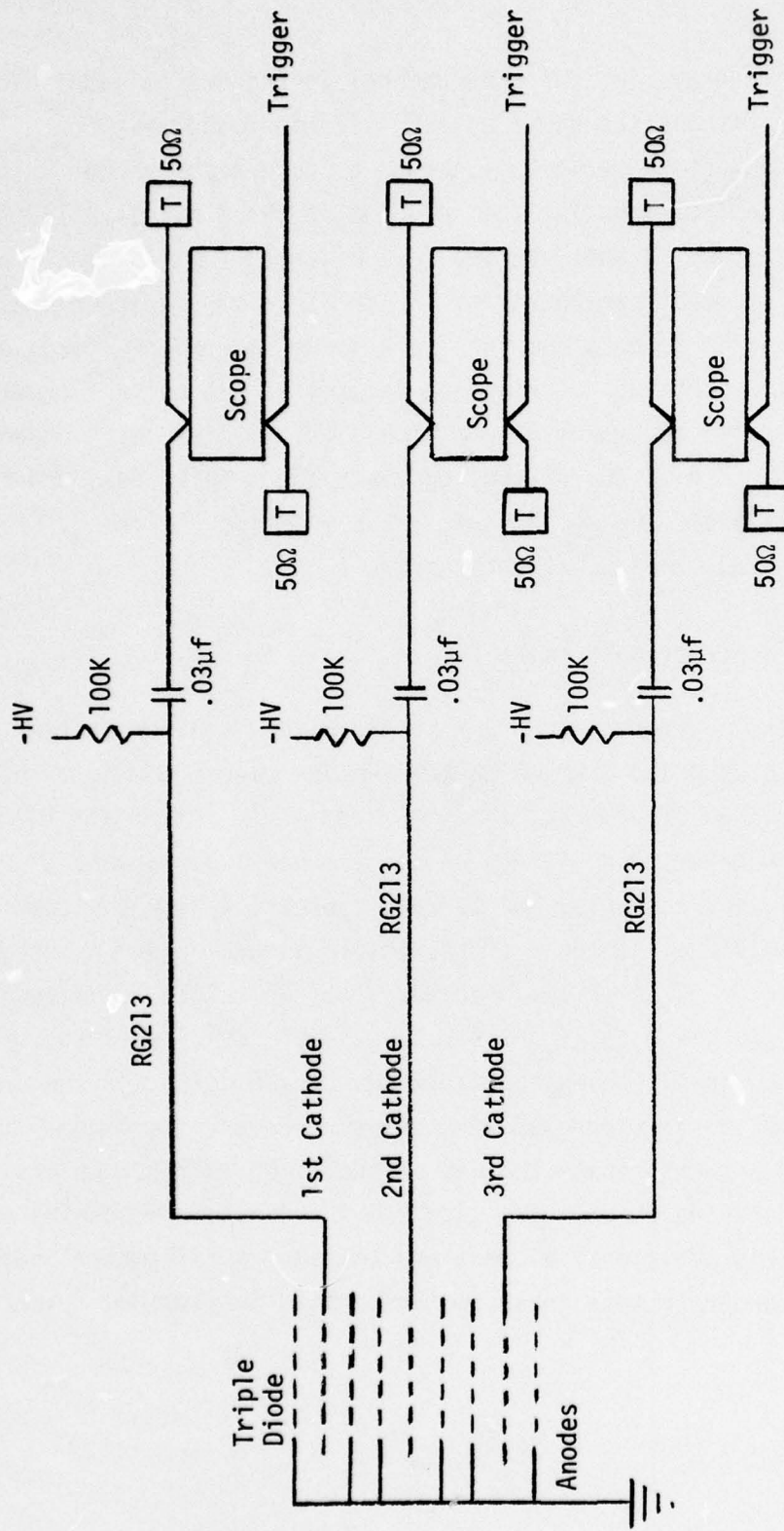

Figure 8. Schematic of Triple Diode Recording Circuit.

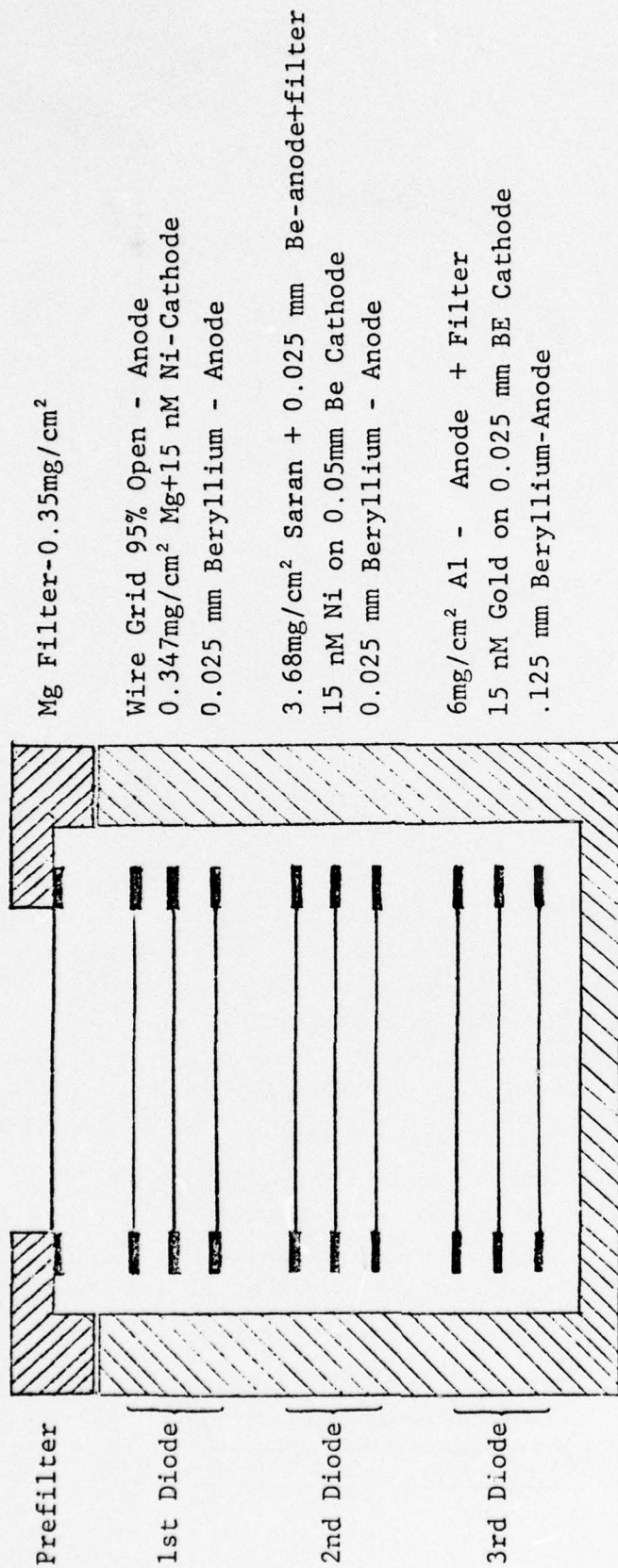

Figure 9. Schematic of the Individual Elements Making up the Triple Diode.

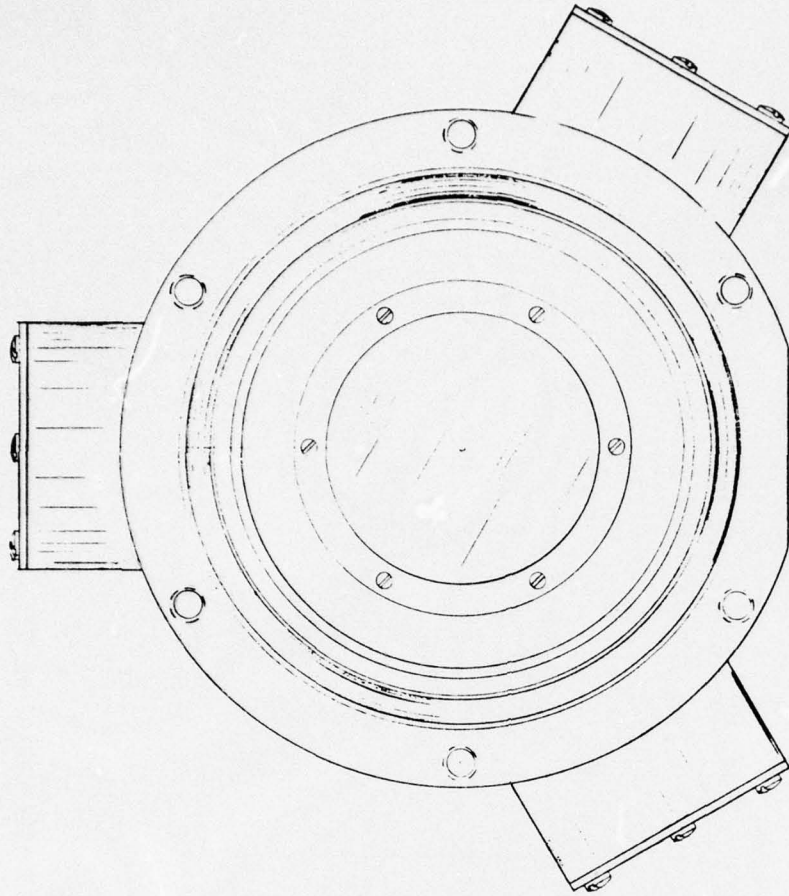
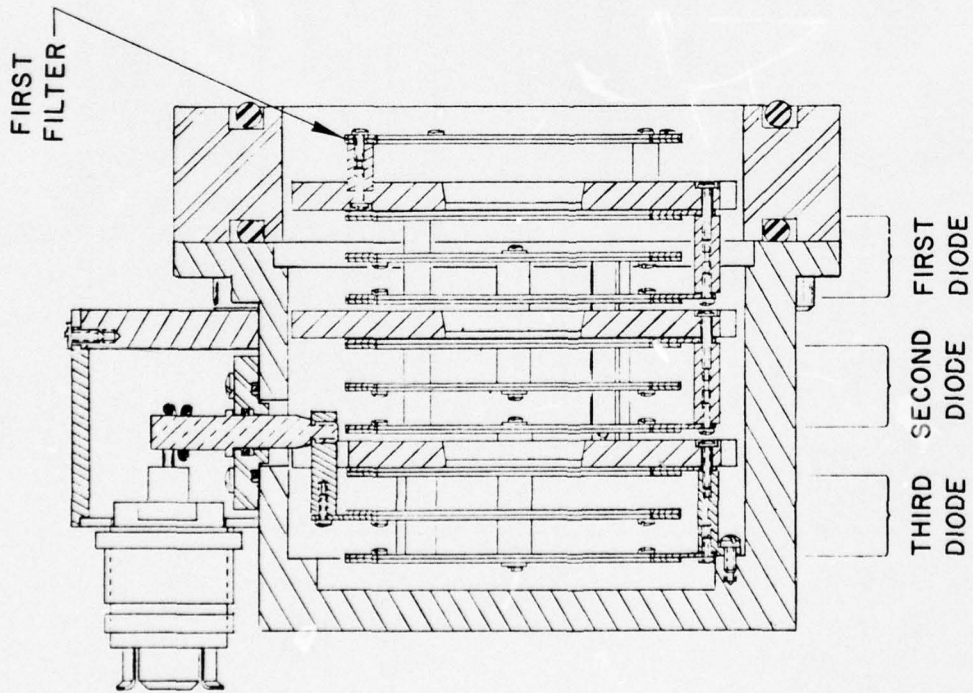

Figure 10. Assembly Drawing of the Triple Diode.



The first filter was required to be  $0.31 \text{ mg/cm}^2$  magnesium foil, an extremely fragile material that must be treated with great care. In the Physics International simulator a shock wave is formed which can exert considerable force on the first foil. Experience showed that an unsupported magnesium foil always ruptured and blew pieces into the diode during the shock. Even the shock of pump-down will rupture the foil if the pumping rate is not severely restricted. In order to circumvent this problem a new foil holder assembly was designed. This consisted of a pair of mating pieces identical in outline to a normal foil holder, but instead of a 4.58 cm diameter open interior, this area was replaced by a pattern of 4.32 mm diameter holes on 4.76 mm centers in a staggered pattern. The result was a 74.4% open area. While this reduced the diode sensitivity somewhat, it completely solved the problem of supporting the thin magnesium foil, and allowed it to survive many cycles of pump-down and pressure shock following the pulse.

#### 2.4 Calibration of the Diode

The triple diode SAI-3 was calibrated using the secondary fluorescence beams from the SAI calibration facility. Table 1 gives the energy of each calibration point and the sensitivity of each diode at that point. We show in Figure 11 the measured data in comparison to the calculated data. Note that only in the tail of the second channel is there any significant difference between the measured and the calculated response.

TABLE 1  
CALIBRATION DATA FOR SAI-3

Fluorescer	Energy keV	Output nW	Channel 1		Channel 2		Channel 3	
			Current pA	Sensitivity $\mu\text{C}/\text{J}$	Current pA	Sensitivity $\mu\text{C}/\text{J}$	Current pA	Sensitivity $\mu\text{C}/\text{J}$
Mg	1.255	.769	0.057	75.0				
Al	1.487	2.01	0.0234	11.6	0.00036	0.17		
Cl	2.64	7.59	0.0792	10.0	0.032	4.2		
Sc	4.12	29.9	0.122	4.1	0.034	1.1	0.022	0.74
Ti	4.55	27.2	0.088	3.2	0.032	1.4	0.036	1.32
V	4.95	30.7	0.78	2.5	0.035	1.2	0.058	1.9
Fe	6.47	59.1	0.0762	1.3	0.045	0.76	0.167	2.8
Ni	7.47	31.5	0.030	0.95	0.016	0.5	0.079	2.5

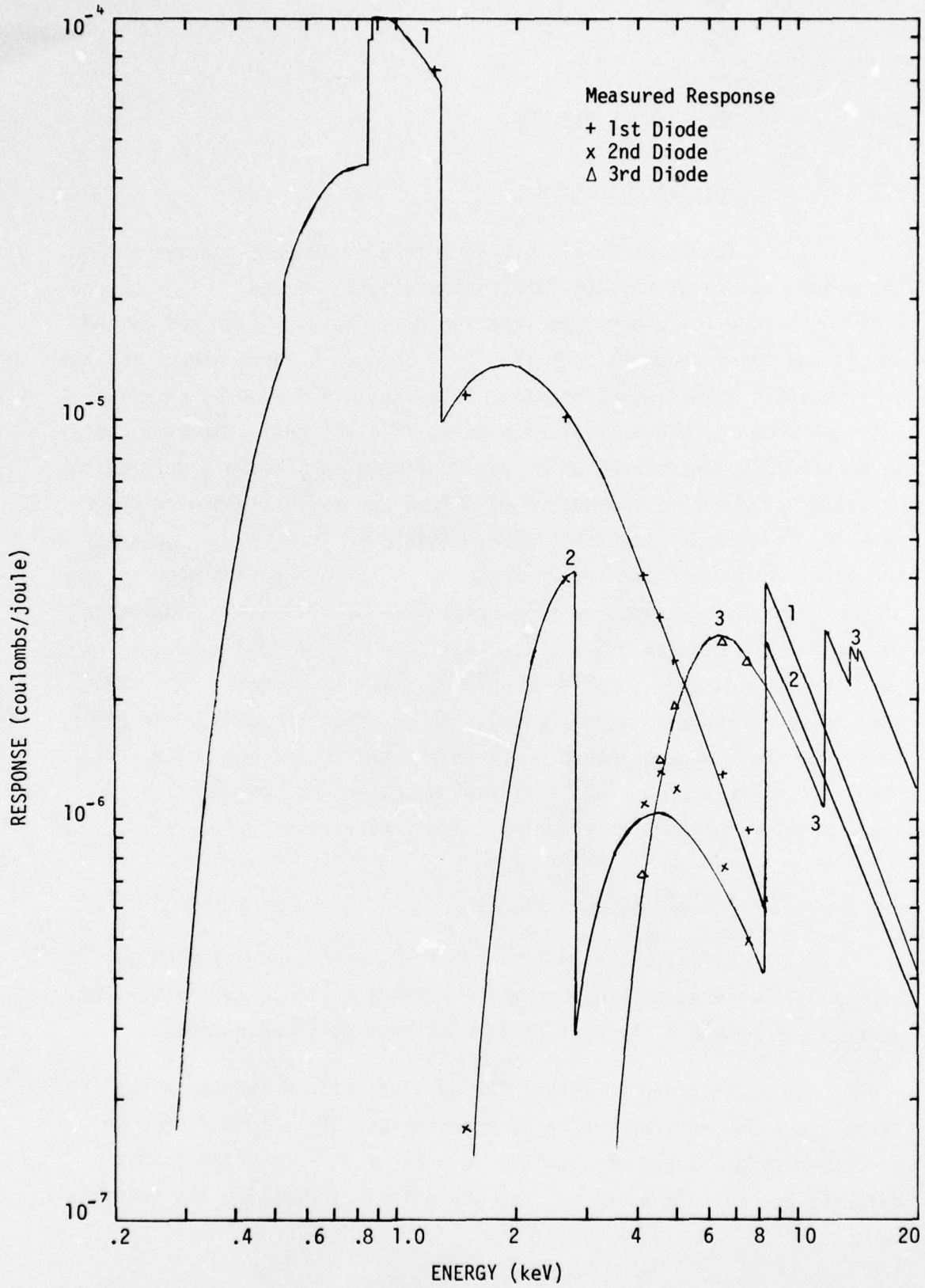

Figure 11. Calculated and Measured Response for the Triple Diode as Built.

### 3.0 OPERATIONAL RESULTS

#### 3.1 Initial Operation

The first trials of the triple diode were carried out on the plasma switch at Physics International by L. Demeter. This source produces a very low energy spectrum and no signal was expected on the second and third channels. On the first channel a large signal followed by a negative signal was observed. This was interpreted as an x-ray pulse followed by the arrival of a pulse of electrons. The time delay supported this conjecture, which was confirmed by placing a deflecting magnetic field across the vacuum path from the source to the detector thus eliminating the negative pulse. Figure 12 is a typical pulse from the first channel of the triple diode, with the deflecting magnets in place. The energy producing this pulse is about  $3.7 \times 10^{-8}$  joules in an energy band between 0.8 and 1.28 keV. In Figure 13 a more complex behavior is apparent. The first pulse is similar, however, a second weak pulse is observed approximately 700 ns after the main pulse and correlates well with a second pulse in the switch voltage. The results were sufficiently promising to warrant operation on the OWL II device where greater intensities and higher energies were expected.

#### 3.2 Exploding Wire Results

A full scale test of the triple diode was carried out in a period of several days during which exploding wire experiments were carried out on OWL II by Kurt Nielsen of Physics International.

In order to insure the survival of the diodes in the largely unknown environment to be encountered, the triple diodes were protected by one layer of aluminum foil  $6.3 \times 10^{-5}$  cm thick. This affected the first channel only to the extent of reducing its sensitivity



Vertical Scale: 5 Volts/Division  
Horizontal Scale: 0.5  $\mu$ sec/Division

Figure 12. Pulse From the First Channel of TriDi Generated by the Plasma Switch.

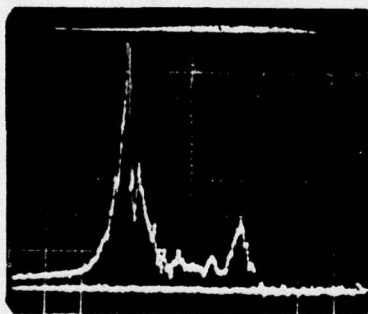

Switch Voltage  
Horizontal Scale: 0.2 nsec/Division

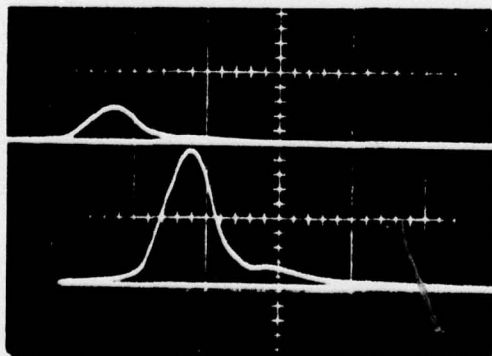

Pulse From Channel 1 of TriDi  
Vertical Scale:  
Upper Trace: 20V/Division  
Lower Trace: 5V/Division  
Horizontal Scale 0.5  $\mu$ sec/Division

Figure 13. Pulse From Channel 1 of TriDi Compared to the Switch Voltage.

at 1 keV by a factor 0.8. Figure 14 shows the sensitivity of all three channels as modified by the aluminum window and the 74% transmission aluminum support plate for the magnesium filter.

A single channel diode using a Kimfol window was employed as a backup detector for the first channel. Its response function is shown in Figure 15. Two scintillation detectors having a response above 2 keV were used as standard detectors since these had been previously calibrated and were known to be reliable indicators of the flux above 2.5 keV and 4.5 keV respectively.

A typical set of traces is shown in Figure 16. Although with only three channels it was not possible to infer an unambiguous spectrum, the results were consistent with a spectrum which monotonically decreased in intensity above an energy of 0.8 keV. There was also evidence of an early low energy component, since the single channel diode produced an intense output some 25 ns earlier than the first channel of the triple diode.

Figure 17 shows the traces obtained for a shot of much different character. Note that there is very little signal for the single diode. The total output is much lower. The second channel of the triple diode produced a much more intense output than in other cases. This type behavior would have been largely missed if one had not had access to an energy selective device such as the triple diode.

Because the first channel has a sensitivity that is similar to the second channel in the 3 - 5 keV region, one concludes that the spectral intensity decreases no more than a factor of five between 1 keV and 10 keV. This is in sharp contrast to the results in Figure 13 where a decline of a factor of 100 is inferred.

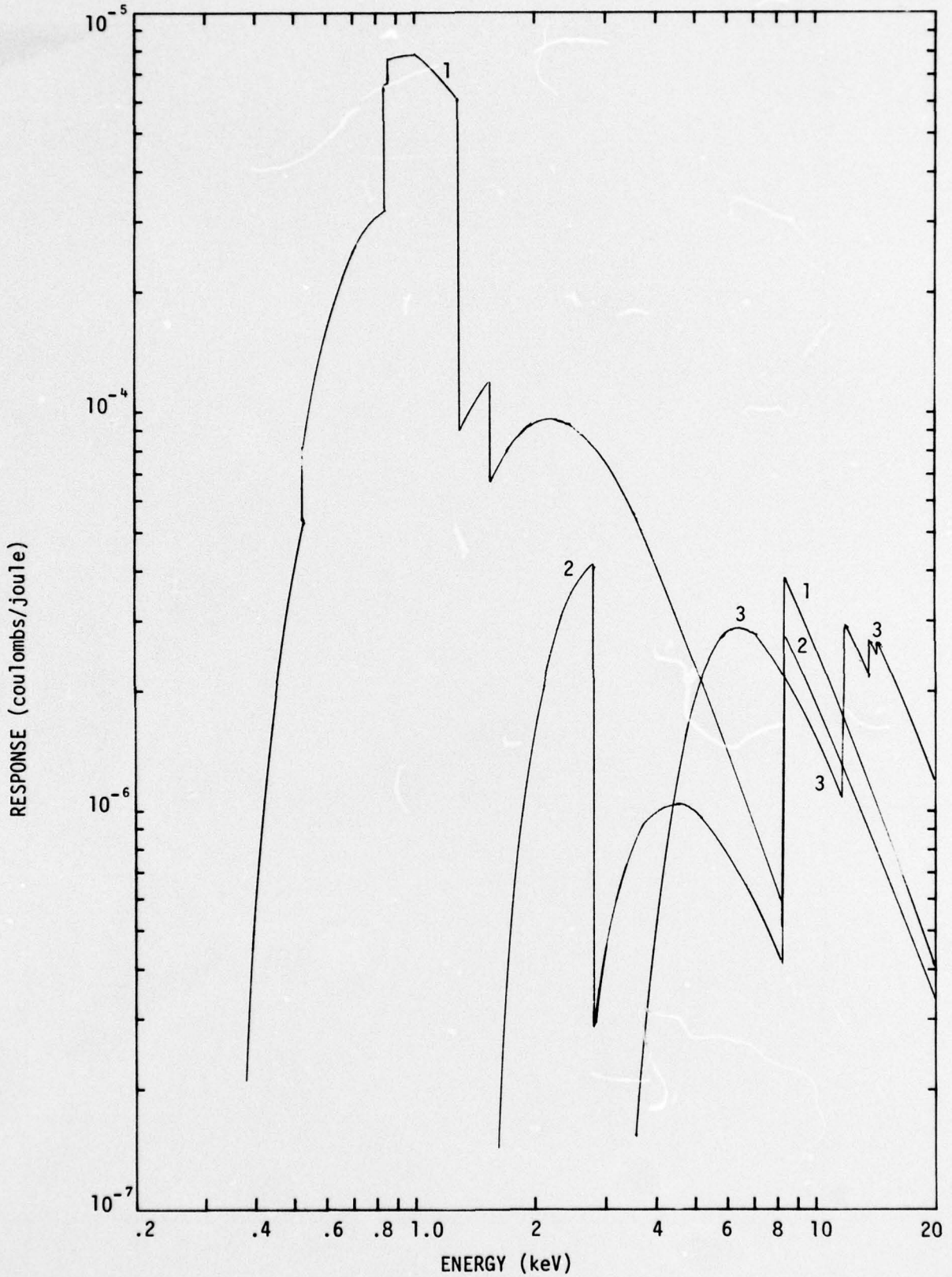

Figure 14. Response of the Triple Diode as Fielded.

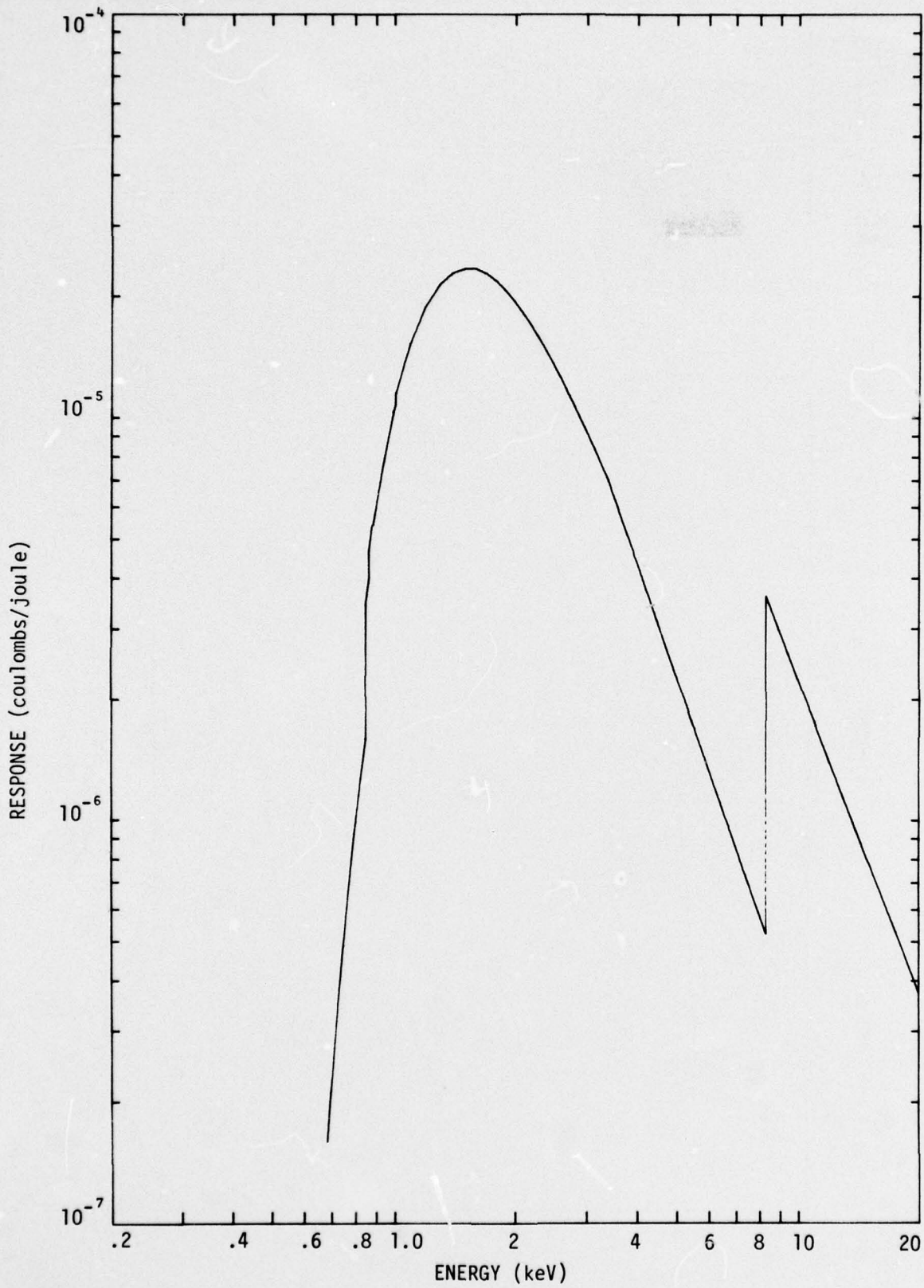

Figure 15. Response of the Single Channel Diode.



Single Channel Diode

Vertical Scale: 20 V/cm

Horizontal Scale: 20 nsec/Division

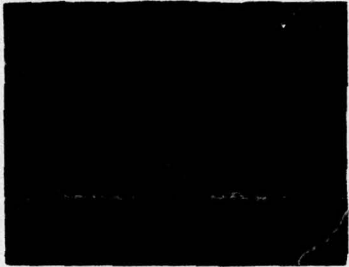

Triple Diode: First Channel

Vertical Scale: 25 V/Division

Horizontal Scale: 50 nsec/Division

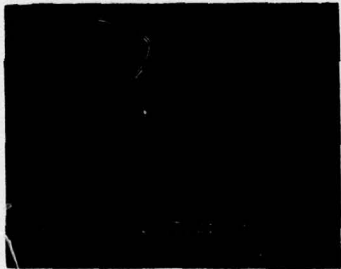

Triple Diode: Second Channel

Vertical Scale: 0.2 V/Division

Horizontal Scale: 50 nsec/Division



Vertical Scale: 0.2 V/Division

Horizontal Scale: 50 nsec/Division

Figure 16. Traces From the Single Channel and Triple Diodes for Shot 1214.

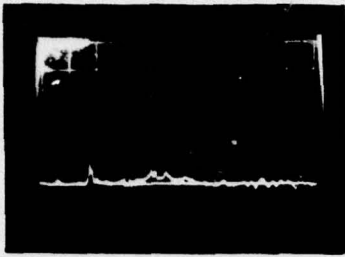

Single Channel Diode

Vertical Scale: 25 V/Division

Horizontal Scale: 50 nsec/Division

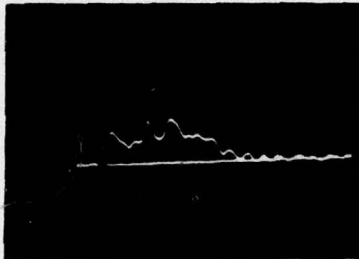

Three Channel Diode: First Channel

Vertical Scale: 20 V/Division

Horizontal Scale: 50 nsec/Division

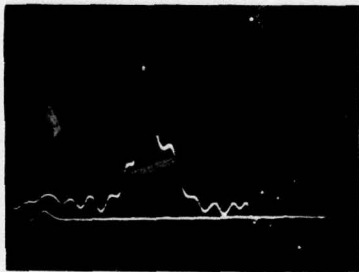

Three Channel Diode: Second Channel

Vertical Scale: 0.2 V/Division

Horizontal Scale: 50 nsec/Division



Three Channel Diode: Third Channel

Vertical Scale: 0.2 V/Division

Horizontal Scale: 50 nsec/Division

Figure 17. Traces From the Single and Three Channel Diodes for Shot 1204.

### 3.3

#### Plasma Heating Experiments

After a period in which both the single and triple diode were used on the plasma switch, the triple diode was again used on OWL II, on this occasion for diagnosis of the plasma heating experiments. At the end of these experiments it was observed that the cathode of the first diode was severely damaged and showed evidence of having been subjected to corona discharge in air. The cathode, a thin magnesium foil with a vacuum deposited film of nickel, is subject to chemical attack under these conditions. The second and third cathodes also appeared to have undergone some severe reaction, which resulted in a dark brown discoloration. All the anodes were relatively clean and the first filter was completely clean and undamaged except for several pinholes. The second cathode was removed and cleaned with acetone and degreased with freon. This treatment restored the surface to its original condition and provided a reasonable explanation of the observed results. There is a significant quantity of oil in the OWL II system. Although the oil itself would not necessarily cause any performance degradation, the oil molecules are ionized as well as degraded in the plasma and by x-ray bombardment. The resultant positive ions were collected on the cathode surface and formed the brown film on the negatively charged cathodes. Unfortunately the first cathode is the most sensitive and collects the majority of these ions as they drift into the diode. We believe that keeping the high voltage on the diode for as little time before and after a shot as is reasonable and cleaning the diode periodically in a good oil solvent (vapor bath or ultrasonic bath) would eliminate the problem and allow the diode to be used indefinitely.

#### 4.0 DESIGN OF A "RATE DIODE"

It is important to have a measure of the total output in a beam independent of the spectrum. SAI has proposed that this objective can be achieved over a limited energy range with an XRD tailored to have a flat response. Although calorimetry is the usual means of obtaining total output information, the tailored XRD or "rate diode" approach has the advantage of providing a time history of the total output.

Initially the program used to design the triple diode was used in an attempt to design a rate diode. A number of trial designs with various diodes and filters led to the conclusion that the simple expedient of paralling several in-line diodes could not be used to produce a good rate diode.

A second approach used the graded aperture method. In this approach a composite aperture is placed in front of a single diode to produce a variable aperture which increases in size with increasing photon energy. Calculations have shown that this technique can provide a limited band of flattened response above the cathode K-absorption edge.

It was desired to design a diode with response that was within  $\pm 10\%$  of the average response over the energy band from less than 1 keV to 15 keV. This requirement is made difficult by the fact that a typical XRD response falls as much as a factor of 100 over this range. It appeared certain that at least two diodes would be necessary and that some type of graded aperture would be required. Reducing the sensitivity of the high energy channel appeared to be a problem and several attempts to achieve this were unsuccessful.

6

A successful technique was finally hit upon. This consisted of placing the low energy diode behind the high energy diode. The high energy channel is constructed with an appropriately sized hole through it to eliminate the absorption that would otherwise occur. It now became possible to use graded apertures on the two diodes as well as various energy filters and hole sizes. Simple calculations indicated that the required total sensitivity, flatness and bandwidth could be achieved, but the number of parameters that had to be varied precluded hand calculation. A new program was written to allow ready changes in these parameters, while insuring that the diameters of the various holes and apertures were compatible.

In Figure 18 is presented the calculated sensitivity for each of four rate diode sections (a two stage graded aperture for each of two XRD's), as well as the summed output. This design could be improved somewhat by introducing a thin nickel window ahead of the second diode to flatten the response through the nickel edge. A thin gold foil could also be included in front of the first diode to flatten the response through the gold L edges. The response of all the diodes would have to be reduced slightly to accommodate this, but a flatness of less than  $\pm 10\%$  with a 20:1 ratio of E max: E Min and an average sensitivity of  $2 \times 10^{-6}$  coulombs/joule would result. This diode could be constructed using the materials and techniques in use at SAI and a schematic of the diode is shown in Figure 19.

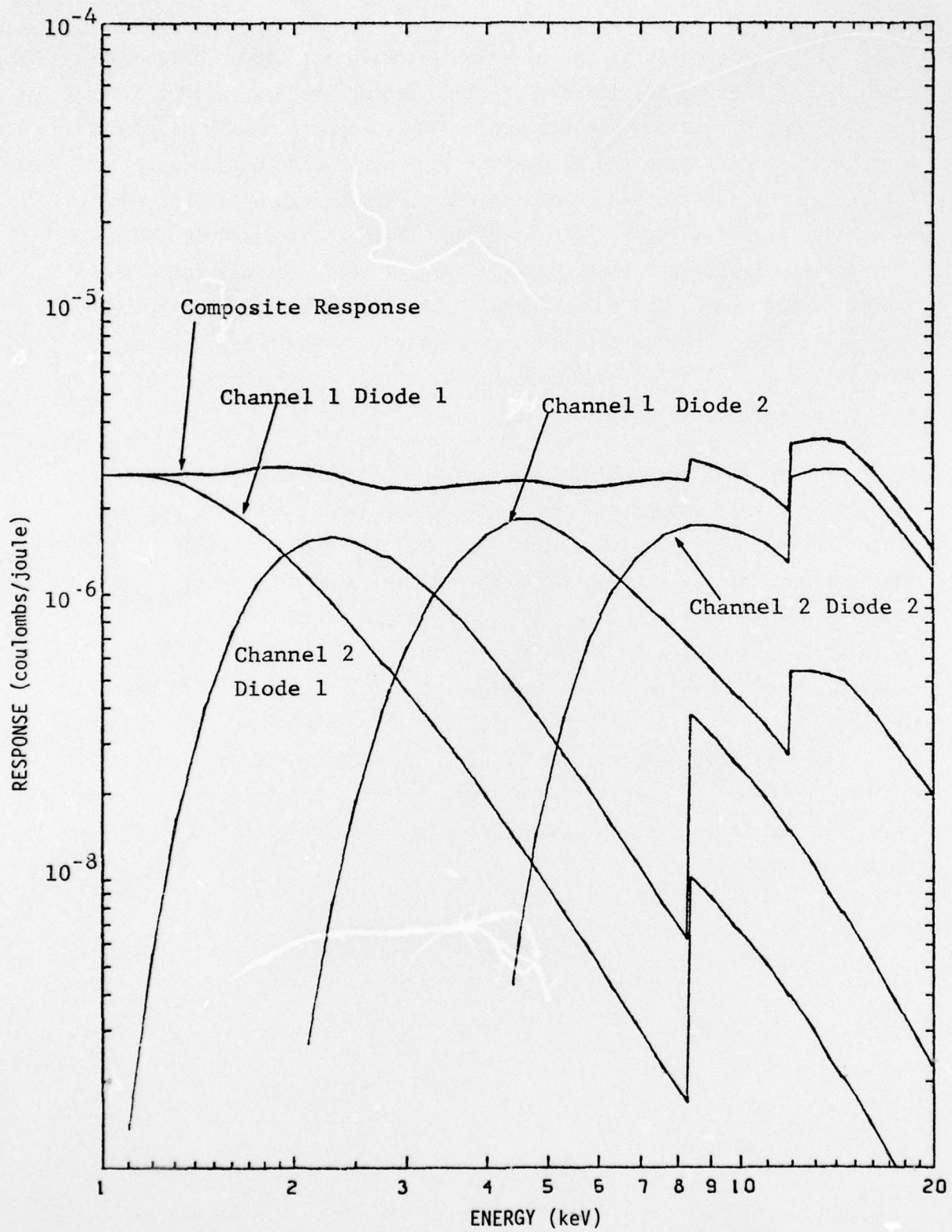
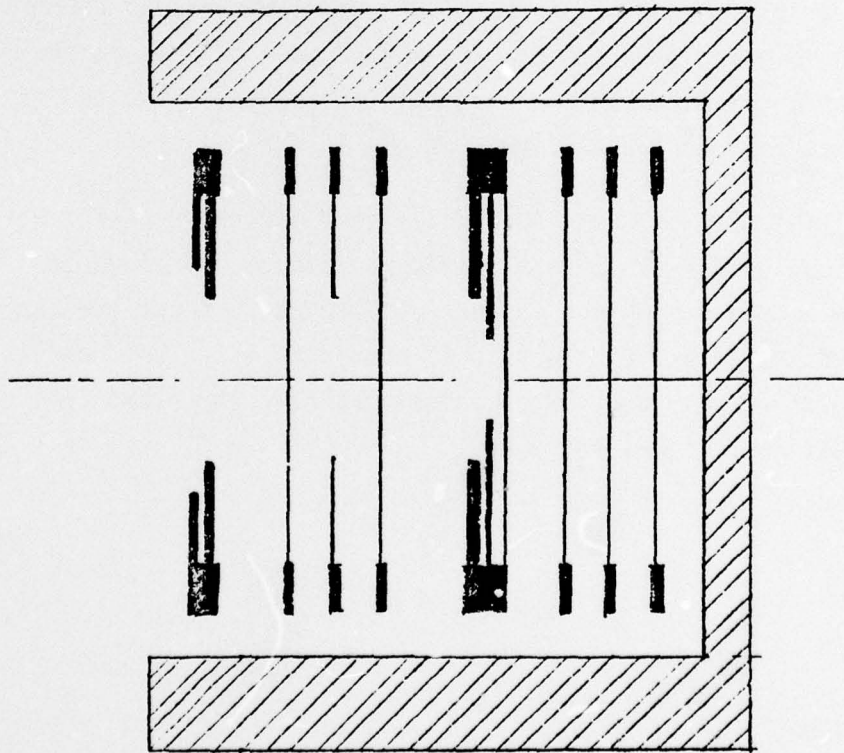

Figure 18. Calculated Response of a Flat Diode.



{ Al Filter 20mg/cm<sup>2</sup>, 0.30 Open  
 { C Filter 18mg/cm<sup>2</sup>, 0.19 Open

Wire mesh anode

40 nM Au on .025 mm Be Cathode, 0.19 Open

Wire mesh anode

{ Au Filter 15mg/cm<sup>2</sup>, 0.19 Open  
 { C Filter 4mg/cm<sup>2</sup>, 0.04 Open  
 { C Filter 0.3mg/cm<sup>2</sup>, 0.00 Open

Wire mesh anode

15 nM Ni on .012 mm Be Cathode  
 .025 mm Be Anode

Figure 19. Schematic Plan of the Flat Diode.

The use of stacked vacuum x-ray diodes appears to be an attractive means of achieving quantitative time resolved diagnostic information on the output of typical simulators. The channel sensitivity and selectivity is adequate and the latter can be improved substantially with little additional effort. In comparison to the plastic scintillator the XRD offers slightly better time response and the important advantage of a tailored response below 2 keV (to as low as 0.5 keV or lower). In addition the stacked diode provides 3 energy channels at a single port. Physics International personnel presently use two scintillators in an effort to achieve minimal spectral definition. All the other techniques in use lack either time response (x-ray diffraction for example), energy response (scintillators), or both (calorimeters).

While some difficulties due to the environment in the sources were encountered, these are well understood and can be easily circumvented or eliminated. In general the results achieved were highly successful and suggest that the stacked x-ray diode can become the mainstay for spectral diagnostics in the simulator program, just as its close relatives the XRD and MXRD have become in the UGT program.

The flat or "rate" diode designed in this project, although not constructed, appears to be a significant advance in this area. The techniques developed to achieve a flat response use a technique not previously considered and are capable of providing excellent results over a very wide energy band. Such diodes may have important applications in the diagnostics of simulator output.