

ADA 036870

RADC-TR-76-355  
Final Technical Report  
November 1976

12



2

RESEARCH ON COATINGS OR SURFACE TREATMENT  
OF METAL POWDERS

IIT RESEARCH INSTITUTE  
10 West 35th Street  
Chicago, IL 60616

Approved for public release; distribution unlimited

DDC  
REFILED  
MAR 14 1977  
REGISTERED  
C  
fo

ROME AIR DEVELOPMENT CENTER  
AIR FORCE SYSTEMS COMMAND  
GRIFFISS AIR FORCE BASE, NEW YORK 13441

COPY AVAILABLE TO DDC DOES NOT  
PERMIT FULLY LEGIBLE PRODUCTION

Dr. Madhav B. Ranade and Dr. Anil Goyal are the co-responsible investigators for this contract. Dr. Joseph J. Hutta (ETSP) is the RADC Contract Monitor.

This report has been reviewed by the RADC Information Office (OI) and is releasable to the National Technical Information Services (NTIS). At NTIS it will be releasable to the general public, including foreign nations.

This technical report has been reviewed and approved for publication.

APPROVED:

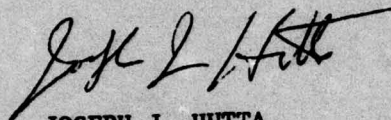

JOSEPH J. HUTTA  
Contract Monitor

APPROVED:

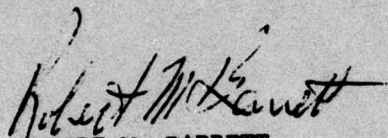

ROBERT M. BARRETT  
Director  
Solid State Sciences Division

FOR THE COMMANDER:

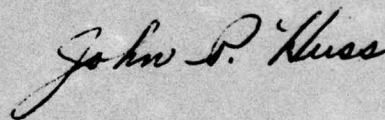

ASSESSOR for

White Section

Buff Section

NTIS

D-2C

ORANGE RINGED

IDENTIFICATION

BY \_\_\_\_\_

DISTRIBUTION/AVAILABILITY CODES

Dist. MAIL and/or SPECIAL

A

9 Final rept. 1 Jun 75 - 31 May 76

Unclassified

SECURITY CLASSIFICATION OF THIS PAGE (When Data Entered)

REPORT DOCUMENTATION PAGE		READ INSTRUCTIONS BEFORE COMPLETING FORM
1. REPORT NUMBER 18 RADC-TR-76-355	2. GOVT ACCESSION NO.	3. RECIPIENT'S CATALOG NUMBER
6. TITLE (and Subtitle) RESEARCH ON COATINGS OR SURFACE TREATMENT OF METAL POWDERS.		5. TYPE OF REPORT & PERIOD COVERED Final Technical 6/1/75 - 5/31/76
7. AUTHOR(s) 10 Madhav B. Ranade Anil/Goyal		8. CONTRACT OR GRANT NUMBER(s) 15 F19628-75-C-0186
9. PERFORMING ORGANIZATION NAME AND ADDRESS IIT Research Institute 10 West 35th Street Chicago, IL 60616		10. PROGRAM ELEMENT, PROJECT, TASK AREA & WORK UNIT NUMBERS 562009-06 61102F
11. CONTROLLING OFFICE NAME AND ADDRESS Deputy for Electronic Technology (RADC/ETSP) LG Hanscom AFB, MA 01731 Monitor/Joseph J. Hutta		12. REPORT DATE 11 August 1976
14. MONITORING AGENCY NAME & ADDRESS (if different from Controlling Office) 16 5620 17 09		13. NUMBER OF PAGES 12 66 p.
16. DISTRIBUTION STATEMENT (of this Report) A - Approved for Public Release		15. SECURITY CLASS. (of this report) Unclassified
17. DISTRIBUTION STATEMENT (of the abstract entered in Block 20, if different from Report)		15a. DECLASSIFICATION/DOWNGRADING SCHEDULE 14 Nov-76 12
18. SUPPLEMENTARY NOTES		
19. KEY WORDS (Continue on reverse side if necessary and identify by block number) Metal Powder                      Release in Vacuum Surface Treatment                Deagglomeration Coating                                Tensile Strength		
20. ABSTRACT (Continue on reverse side if necessary and identify by block number)  Over		

D D C  
R  
MAR 14 1977  
RECEIVED  
C

175350

20. This report describes the research performed under the above contract. The objective of the contract was to assess several techniques utilizing surface treatments or coatings on micron sized metal powders to overcome their agglomerating properties.

Under the contract, several techniques including surface treatments, polymer coating and additions of flow agents were investigated. Special efforts including, a literature review and experimental adhesion force measurements were directed towards understanding the forces holding the particles. Treatments were evaluated by the measurement of interparticle adhesion forces, tensile strength of powders and release characteristics of the powders in vacuum. A treatment with steam appears to give the best flowing and dispersion characteristics to the powder in air and a  $10^{-4}$  vacuum. The steam treated powder also showed a low tensile strength and a low interparticle force of attraction.

.0001

## EVALUATION

1. This report is the Final Report on the contract. It covers research done on the deagglomeration of aluminum powder during the twelve month period 1 June 1975 to 31 May 1976. The objective of the research is the deagglomeration of aluminum powder particles of specific type and origin so as to render it completely dispersible in a high vacuum regime without necessity for complex dispensing mechanisms. Coatings, surface modification and additives were the approaches used to defeat the forces of attraction acting between the fine particles. Of these, surface modification by controlled oxidation in a steam atmosphere proved to be the most effective method for deagglomeration and dispersal in vacuum. Spacer-particle additives promoted deagglomeration but were less effective for dispersal in vacuum.

2. The above work is of value since it provides a solution to the problem of uniform dispersal of fine particles, thereby enabling attainment of an optical signature that approaches optimum for countermeasures applications.

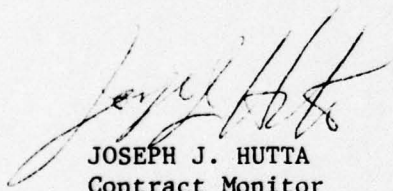

JOSEPH J. HUTTA  
Contract Monitor  
Solid State Sciences Division

## TABLE OF CONTENTS

	<u>Page No.</u>
1. INTRODUCTION .....	1
2. LITERATURE REVIEW .....	1
2.1 Adhesion Between Metal Particles .....	1
2.2 Measurement of Force of Adhesion .....	3
2.3 Powder Flow Properties .....	3
2.4 Powder Treatment .....	4
3. EXPERIMENTAL WORK .....	5
3.1 Test Powder Characterization .....	5
3.2 Water Treatment .....	5
3.3 Steam Treatment .....	9
3.4 Stearic Acid Treatment .....	13
3.5 Silicone and Siloxane Treatments .....	16
3.5.1 HMDS Treatment .....	16
3.5.2 DMPS Treatment .....	16
3.6 Use of Spacer Particles .....	17
3.7 Polymer Coating .....	17
3.8 Measurement of the Adhesion Force .....	22
3.9 Tensile Strength Measurement .....	30
3.10 Powder Release in Vacuum .....	36
4. DISCUSSION OF RESULTS .....	51
5. CONCLUSIONS AND RECOMMENDATIONS .....	55
REFERENCES .....	57

## LIST OF FIGURES

		<u>Page No.</u>
1.	Coulter Counter Analysis for the Test Powder .....	6
2.	Size Analysis of Untreated Al Powders by Optical Microscopy .....	7
3.	Micrograph of Untreated Al Powder No. 6-f .....	8
4.	Photomicrograph of Water Treated Al Powder .....	10
5.	Size Analysis of Water Treated Al Powder by Optical Microscopy .....	11
6.	Apparatus for Steam Treatment .....	12
7.	Photomicrograph of Steam Treated Al Powder .....	14
8.	Size Analysis of Steam Treated Al Powder by Optical Microscopy .....	15
9.	Photograph of Spray Set-Up .....	19
10.	Electronmicrograph of Al Powder Sprayed with Polystyrene in Solvent .....	21
11.	Centrifuge Insert .....	23
12.	Centrifuge Rotor with Tubes .....	24
13.	Forces of Attraction Between an Aluminum Sphere and a Flat Aluminum Plate .....	28
14.	Apparatus for Measurement of Tensile Strength of Powders .....	31
15.	Photograph of Tensile Strength Measurement Cell....	32
16.	Angle Measurement for Tensile Strength Determination	33
17.	Apparatus for Release of Powder in Vacuum .....	37
18.	Photographs for Powder Released in Vacuum .....	38
19.	Photograph of Powder Release Apparatus .....	39
20.	Photographs of Powder Released in Vacuum .....	41
21.	Sample Locations in Vacuum Release Apparatus .....	45
22.	Size Distribution of the Vacuum Released Powder at Different Locations .....	49
23.	Size Distribution of the Vacuum Released Powder at Different Locations .....	50

LIST OF TABLES

	<u>Page No.</u>
1. Proportion of Spacer Particle Additives .....	18
2. Combination of Al powder and Polymer for Encapsulation Feasibility .....	20
3. Adhesion Measurement in Air .....	26
4. Effect of Hardness on van der Waals Adhesive Force Between a 5 $\mu$ m Diameter Sphere and a Flat Surface at a Separation of .4 nm .....	29
5. Tensile Strength Measurement .....	35
6. Type of Powders Released in Vacuum .....	40
7. Size Distribution of the Vacuum Released Original Powder at Different Locations.....	46
8. Size Distribution of the Vacuum Released Water Treated Powder at Different Locations .....	47
9. Size Distribution of the Vacuum Released Steam Treated Powder at Different Locations .....	48

# RESEARCH ON COATINGS OR SURFACE TREATMENT OF METAL POWDERS

## 1. INTRODUCTION

Small particles in the micron size range exhibit agglomeration resulting from the attractive forces which are accentuated due to the high surface area of the particles in comparison to their mass. Dispersion of fine powders into discrete particles is therefore difficult. The aluminum powder, of the primary importance in this program, shows poor flow and dispersion properties in air and vacuum.

Under this program, an assessment of several techniques utilizing surface treatments or coatings of the aluminum particles to improve the flow and dispersion properties was conducted. Several treatments were tried and the effects on the dispersion characteristics were viewed theoretically as well as experimentally in order to correlate them with the interparticle forces.

In this report, the results of the work performed under this program are presented.

## 2. LITERATURE REVIEW

A thorough search of published literature involving adhesion between particles, powder flow properties, and treatments and coatings of powders was conducted. In this search, special emphasis was put on metal powders. A review of the pertinent literature is given below.

### 2.1 Adhesion Between Metal Particles

Small particles, metallic as well as non-metallic, exhibit considerable interparticle forces such as the molecular (van der Waals), electrostatic, and metal bonds. These forces are usually attractive in nature resulting in agglomeration.

The subject of particle adhesion has been studied quite extensively, both theoretically and experimentally. However, gaps in theory and experiments exist.

Reviews of adhesion literature have been published by Zimon (1), Krupp (2), and Corn (3). The principle forces binding fine particles together are (a) van der Waals forces, (b) electrostatic forces, and (c) metallic bonds. It is well accepted that metallic forces do not play a significant role at ordinary temperatures (i.e., below the Tammarrntemperature  $T = 0.5 \times$  melting point temperature).

The van der Waals force between two spherical particles is given by

$$F_A = \frac{Ad_p}{12Z_o} \quad (1)$$

where  $A$  is the Hamaker constant,  $d_p$  is the particle diameter, and  $Z_o$  is the distance of minimum separation between the particles. The Hamaker constant is obtained from spectroscopic data. The distance of separation,  $Z_o$ , is obtained by comparison of adhesion data and the theory (Equation 1). Arbitrarily, it must be greater than atomic dimensions. Values ranging from 0.4 nm to 1.5 nm have been reported. A value of 0.7 nm is a useful average.

Shielding of van der Waals forces by adsorbed films was studied theoretically by Vold (4).

The electrostatic force between a metallic sphere and half space is given by Krupp (2) as

$$F_A = \pi \epsilon_o R \cdot \frac{U^2}{Z_o} \quad (2)$$

where  $\epsilon_o$  is the dielectric constant,  $U$  is the contact potential difference,  $R$  is the particle radius, and  $Z_o$  is the minimum distance of separation.

## 2.2 Measurement of Force of Adhesion

Several experimental techniques for the measurement of adhesion force have been used. Zimon (1) has reviewed the various methods. For the determination of adhesion force, a system of particles and a flat surface is usually employed. The methods applicable to particles smaller than 10  $\mu\text{m}$  are (a) centrifugal technique, (b) vibration, and (c) aerodynamic technique. Of these three methods, the centrifugal technique is amenable to accurate calculation of the force applied to the particles. In a commercial laboratory, ultracentrifuge forces up to the particle mass times 500,000g may be applied. Böhme (5) has developed a special centrifuge for operating at accelerations up to  $10^6$  in a vacuum. Significant publications have come out of the Battelle-Institute from their group.

Böhme, et.al. (6) used the ultracentrifuge to measure forces between gold spheres (2-8  $\mu\text{m}$  diameter) on silicon single crystals and gold substrates in ultra-high vacuum. They compared their results with the van der Waals and electrostatic theoretical estimates and concluded that for gold, a metal, the van der Waals forces were dominant.

Donald (7) studied adhesion of gold on gold substrates and concluded that electrostatic forces are significant if the metal adherents are separated by a film of oxide layer. He expressed the electrostatic component as

$$F_A = \beta R^{2(\eta - 1)} \quad (3)$$

Deviation from a straight line relationship of the force vs. particle size data would represent significant contributions from electrostatic efforts.

## 2.3 Powder Flow Properties

Pietsch (8) reviewed the agglomerating behavior of fine particles. For dry powders, the attraction forces between particles (Section 2.1) are significant and lead to agglomeration. Rumpf (9) has calculated the strength of a powder bed

based on the attractive forces between the particles. A relationship between the microscopic theory and powder properties is demonstrated. Zimon (1) has also discussed the relationship of discrete interparticle forces and the properties of the bulk powder.

Salisbury (10) studied adhesion behavior of silicate powders in an ultra high-vacuum. Adhesion was low in air and in vacuum after oil contamination. This indicated that the van der Waals forces were shielded by an adsorbed film, leading to the conclusion that the electrostatic forces were not dominant.

#### 2.4 Powder Treatment

The presence of an oxide layer on aluminum surfaces has been known to reduce adhesion between the particles. Under ordinary atmospheric conditions, aluminum acquires an oxide film by adsorption. A study conducted by Kaiser Aluminum & Chemical Co. (11) shows that adsorbed oxide and water on aluminum still persisted after six hours at 600°F in a  $4 \times 10^{-4}$  Torr vacuum.

The oxide film formed by natural processes is probably non-continuous and porous. A continuous film could be produced by reaction with boiling water or by a steam treatment. In a Czech Patent to Svoboda, et.al., (12), use of wet steam with a trace quantity of  $\text{NH}_3$  was shown effective in producing a protective oxide coating on objects coated with aluminum by vapor deposition.

Silylation of powders has been reportedly useful for deagglomerating powders. Procedures for silylation are given by Bohemen (13) and Sweeley, et.al., (14). This treatment reduces attraction by shielding the particles from each other by the large silyl groups.

Encapsulation techniques have been reviewed extensively by Vandeager (15). This included coacervation, vapor phase

deposition, and electrostatic encapsulation. Use of in situ polymerization of styrene monomer deposited on particles is also practical. Maylotte and Wright (16) polymerized trifluoroethylene on solid surfaces at about 0.5-10 Torr by UV activation. Extension of this method on coating of powders depends on the dispersion of the powders in a vacuum.

In a study at General Mills (17), use of Cab-O-Sil as spacer particles was shown to be effective in improving the flow properties of a starch powder.

### 3. EXPERIMENTAL WORK

#### 3.1 Test Powder Characterization

The primary powder for the surface treatment studies was an aluminum powder formed by atomization of molten aluminum. Close size cuts of this powder were supplied by AFCRL. Coulter counter size analyses of the powders were also supplied by AFCRL (Figure 1). The size distributions of the powders were measured in our laboratory by an optical microscope interfaced with an image analyzing computer (Imanco). The size distributions of the fine and coarse cuts are shown in Figure 2. A photomicrograph and an electronmicrograph are presented in Figure 3.

#### 3.2 Water Treatment

Under ambient environment conditions, aluminum possesses an oxide layer. This layer, however, does not form a continuous layer around the particles. Formation of a continuous oxide layer by anodic treatment is used for protection of aluminum parts. We found that by reacting water with aluminum near the boiling point of water, a layer of hydrated oxide is formed around the particles. The flow properties of the dried powder had improved significantly. However, microscopic examination of this treated powder showed that sintering of several aluminum particles into single particles, and complete

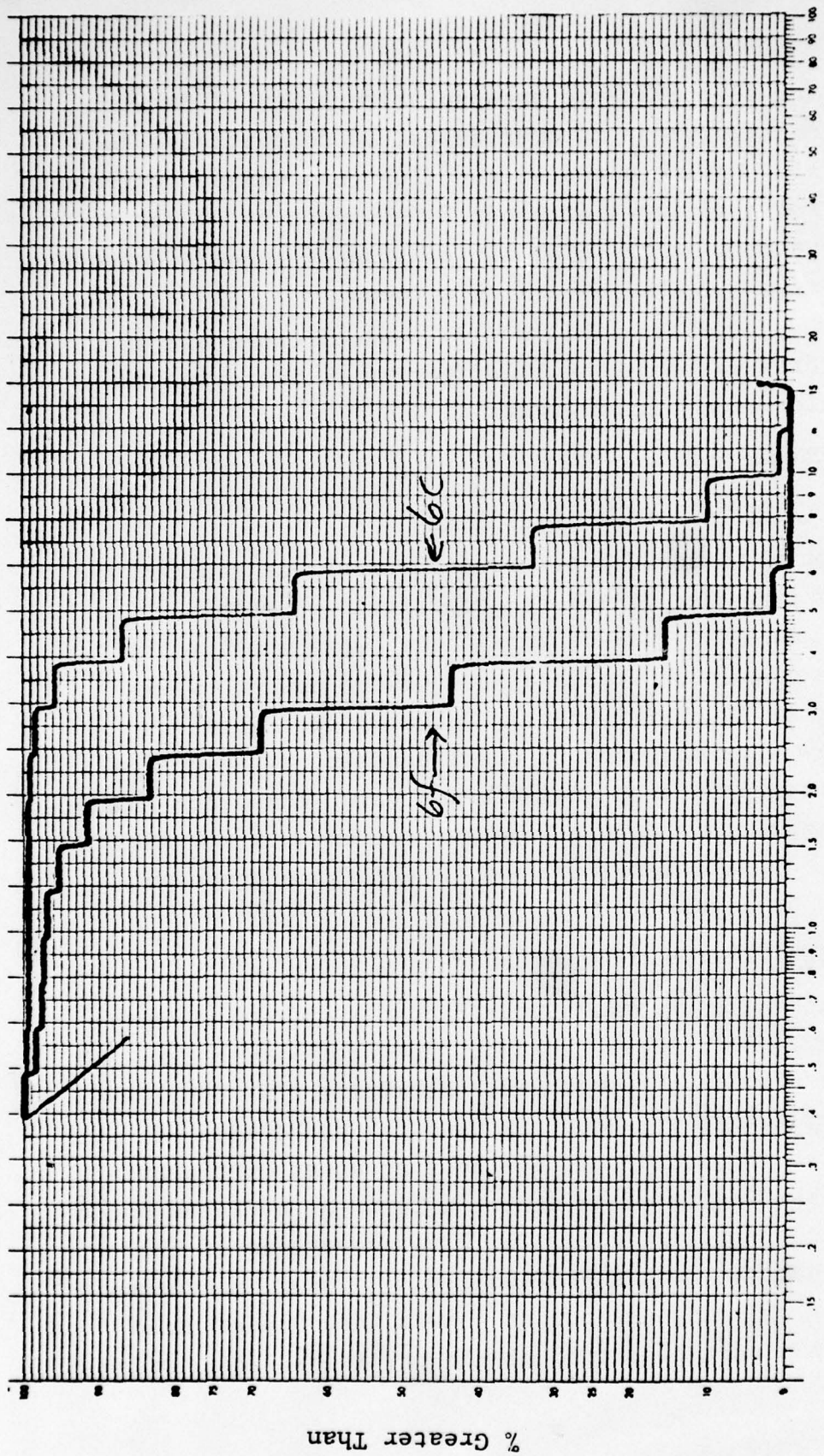

Particle Size,  $\mu\text{m}$

Figure 1

COULTER COUNTER\* ANALYSIS FOR THE TEST POWDER

(\*Supplied by AFCRL)

% Greater Than

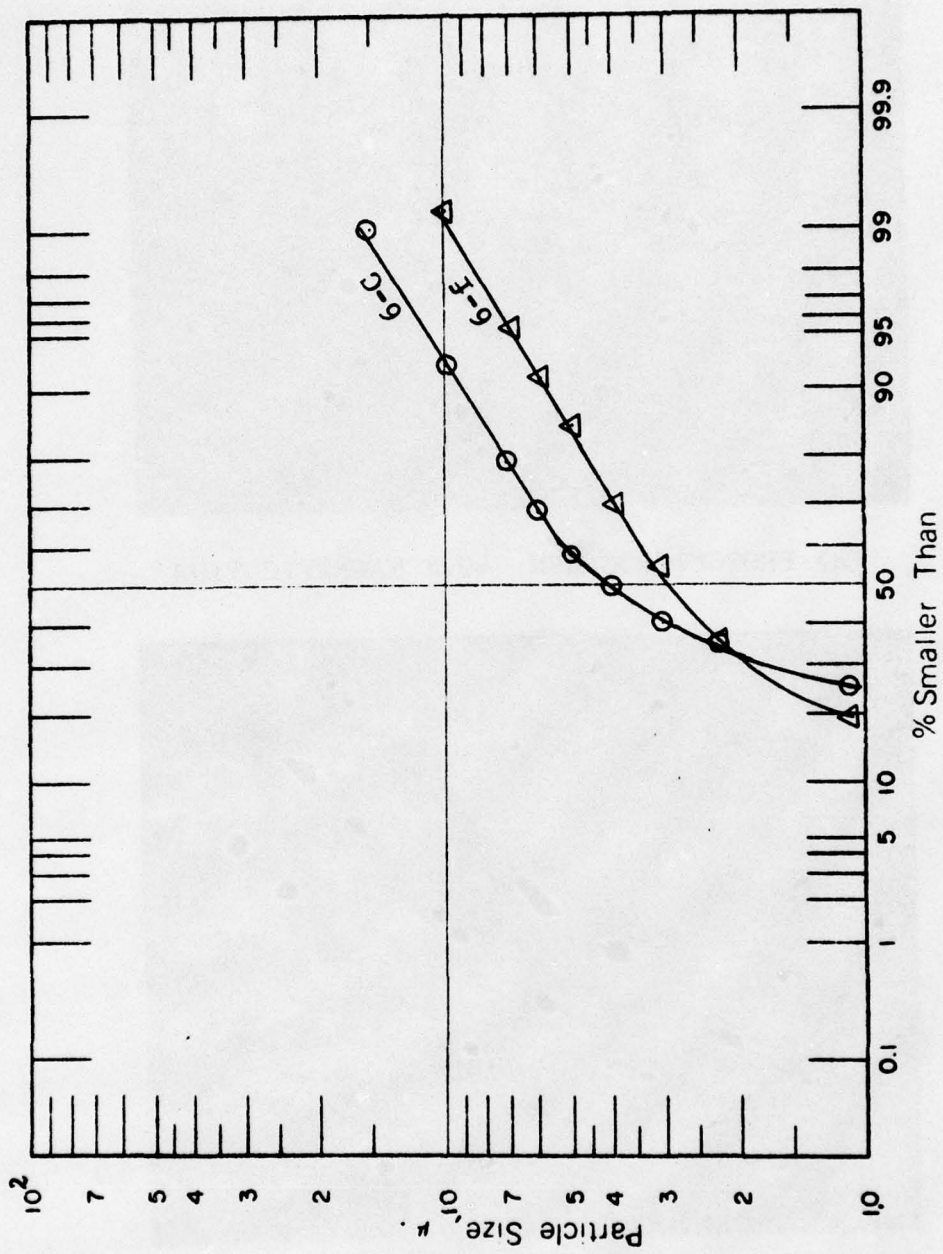
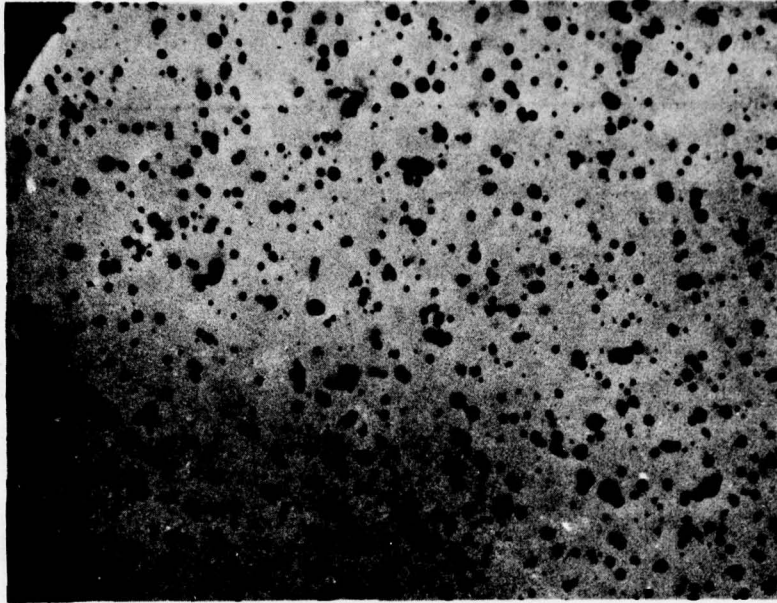
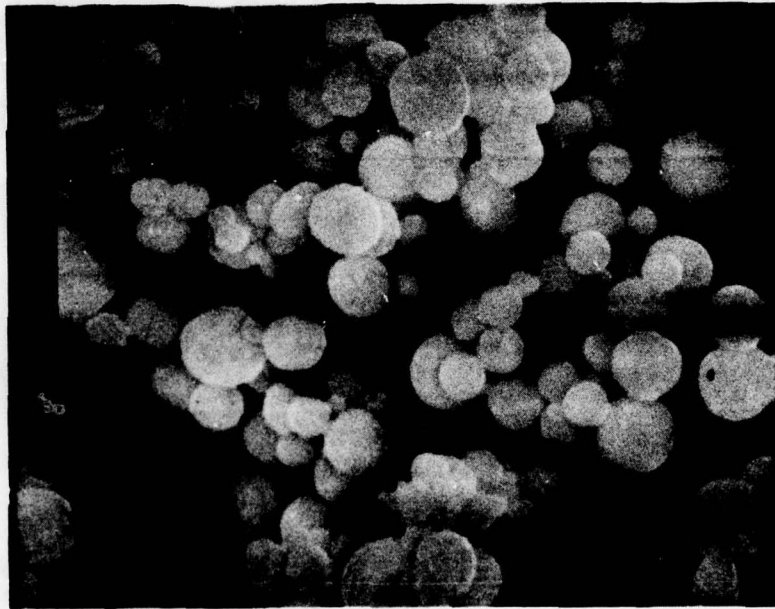

Figure 2  
 SIZE ANALYSIS OF UNTREATED Al POWDERS BY OPTICAL MICROSCOPY



3(a) PHOTOMICROGRAPH; 400X MAGNIFICATION



3(b) ELECTRON MICROGRAPH; 3,000X MAGNIFICATION

Figure 3  
MICROGRAPH OF UNTREATED Al POWDER NO. 6-f

conversion of some aluminum particles to aluminum oxide were taking place. A photomicrograph of the aluminum powder treated with water is shown in Figure 4. A size analysis by optical microscopy is shown in Figure 5.

This water treatment was optimized with respect to temperature and time of reaction. The optimum temperature and time appears to be 90°C and 15 minutes, respectively. Reacting the aluminum powder for a longer time did not further improve its flow property appreciably. Following the results of Svoboda, et al. (12) we investigated the effect of ammonia on the treatment by adding  $\text{NH}_4\text{OH}$  to the water. It did not seem to have any measurable influence on the flow behavior of the aluminum powder.

The reaction products formed on the surface of the aluminum particles was identified as Bayerite  $\text{Al}(\text{OH})_3$  or  $\alpha \cdot \text{Al}_2\text{O}_3 \cdot 3\text{H}_2\text{O}$  by x-ray diffraction analysis of the powder. In order to form enough of this material, it was necessary to extend the reaction time to six hours.

Controlling the oxide formation to a relatively thin layer around each particle is necessary for successful treatment. We chose to use steam to react with aluminum particles to achieve this control, which is described next.

### 3.3 Steam Treatment

An apparatus was designed to react the aluminum powder with steam in a fluidized state (Figure 6). It is a batch reactor system. Steam was generated in a three neck glass flask. When steam started coming out of the reactor, the reactor was fed with a small quantity of the aluminum powder. The reactor tube was slightly heated by placing an electrical coil around it to prevent excessive condensation. The aluminum particles were fluidized by the steam. The reactor tube was removed after about five minutes and the sample taken out. The sample was ground in a mortar and pestle. This treated powder showed

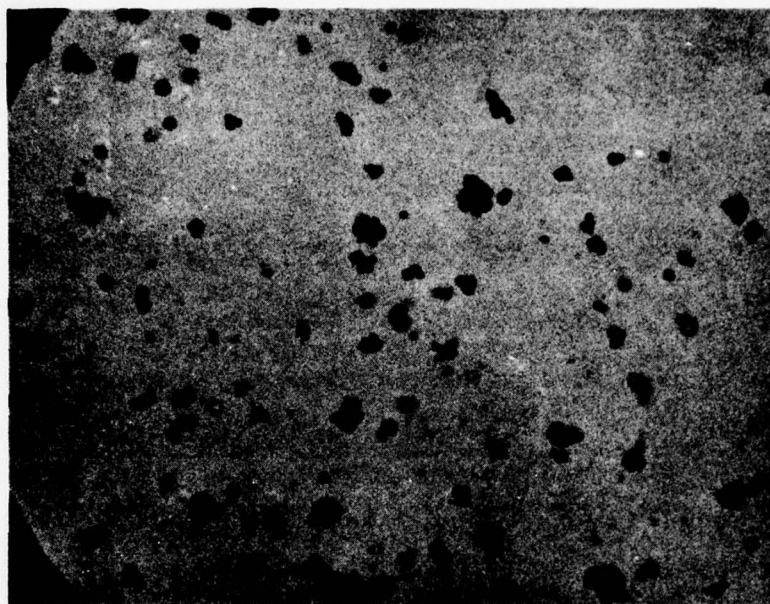

Figure 4

PHOTOMICROGRAPH OF WATER TREATED Al POWDER

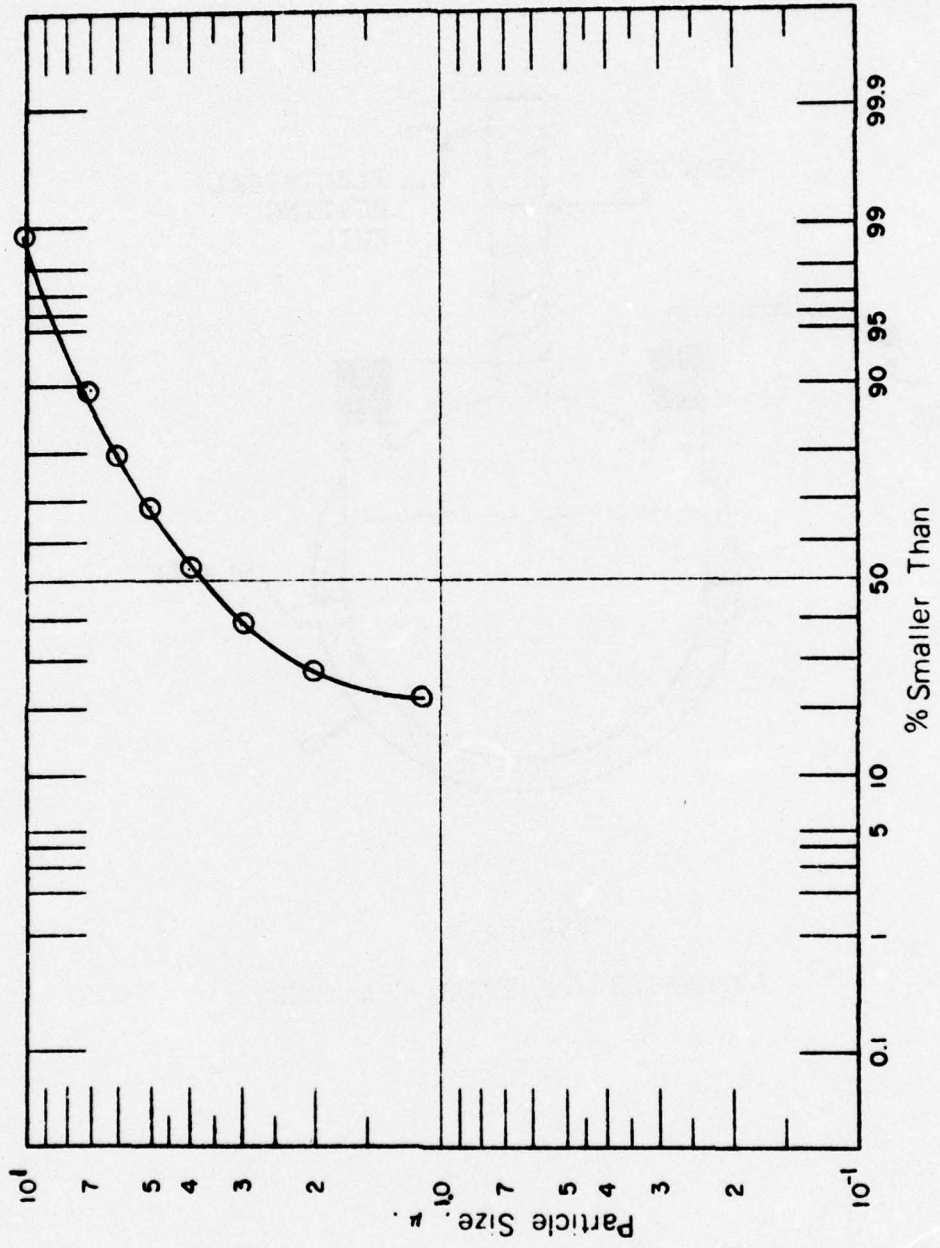

Figure 5  
 SIZE ANALYSIS OF WATER TREATED AL POWDER  
 BY OPTICAL MICROSCOPY

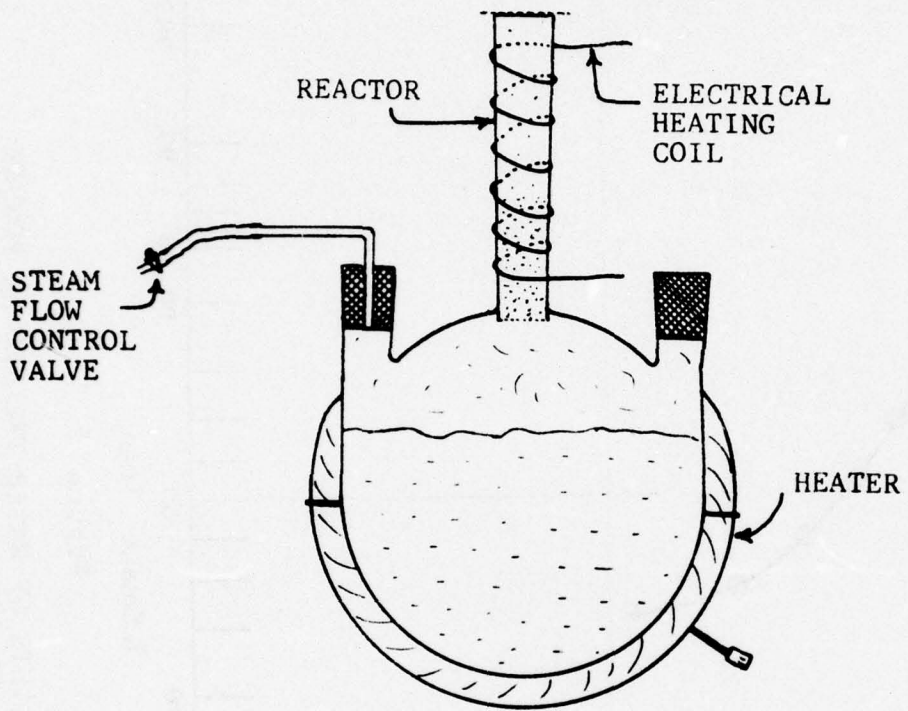

Figure 6  
APPARATUS FOR STEAM TREATMENT

good flow properties. A photomicrograph of the treated powder is given in Figure 7. Size analysis of this powder by optical microscopy is given in Figure 8. The average particle size of this sample is larger than the original powder since some fines present in the original powder were carried away by the steam.

The powder was also reacted in a fixed bed rather than a fluidized bed. Similar results were obtained.

The surface area of the raw powder (measured by nitrogen adsorption method using Micromeritics surface area-pore volume analyzer Model 2100D) was  $1.6\text{m}^2/\text{gm}$ , while the surface area of treated powder was  $24.6\text{m}^2/\text{gm}$ , which is significantly higher.

To react the aluminum powder with a mixture of steam and ammonia, ammonium hydroxide was added in the flask. The treated powder had better flowing property than the original powder but no improvement was found over the treatment with steam alone.

The powder was also reacted with superheated steam, but no improvement in the flow property was evident. (The steam used above was wet.) This shows that the presence of moisture is necessary in steam treatment.

### 3.4 Stearic Acid Treatment

Earlier experiences indicated that stearic acid could be applied to aluminum powder forming aluminum stearate on the particle's surface. This causes a reduction in the adhesive forces between individual particles. With this in mind, two types of application were attempted: (a) vapor deposition of stearic acid onto aluminum powder, and (b) adsorption of stearic acid onto individual particles by grinding.

- (a) Stearic acid was placed in ceramic boat and vaporized in a tube furnace. When vapor was present, the aluminum powder aerosol generated by Wright Dust Feeder was introduced into the tube section. The resulting aerosol was sampled and collected on a Nuclepore filter. The filter was inspected visually and microscopically. Examination of the filtrate and filter did not reveal any change in adhesive properties.

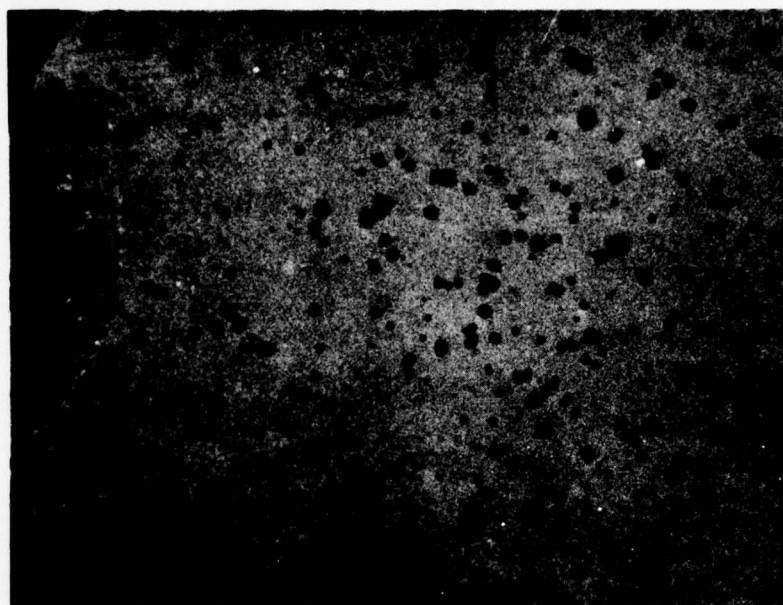

Figure 7

PHOTOMICROGRAPH OF STEAM TREATED Al POWDER

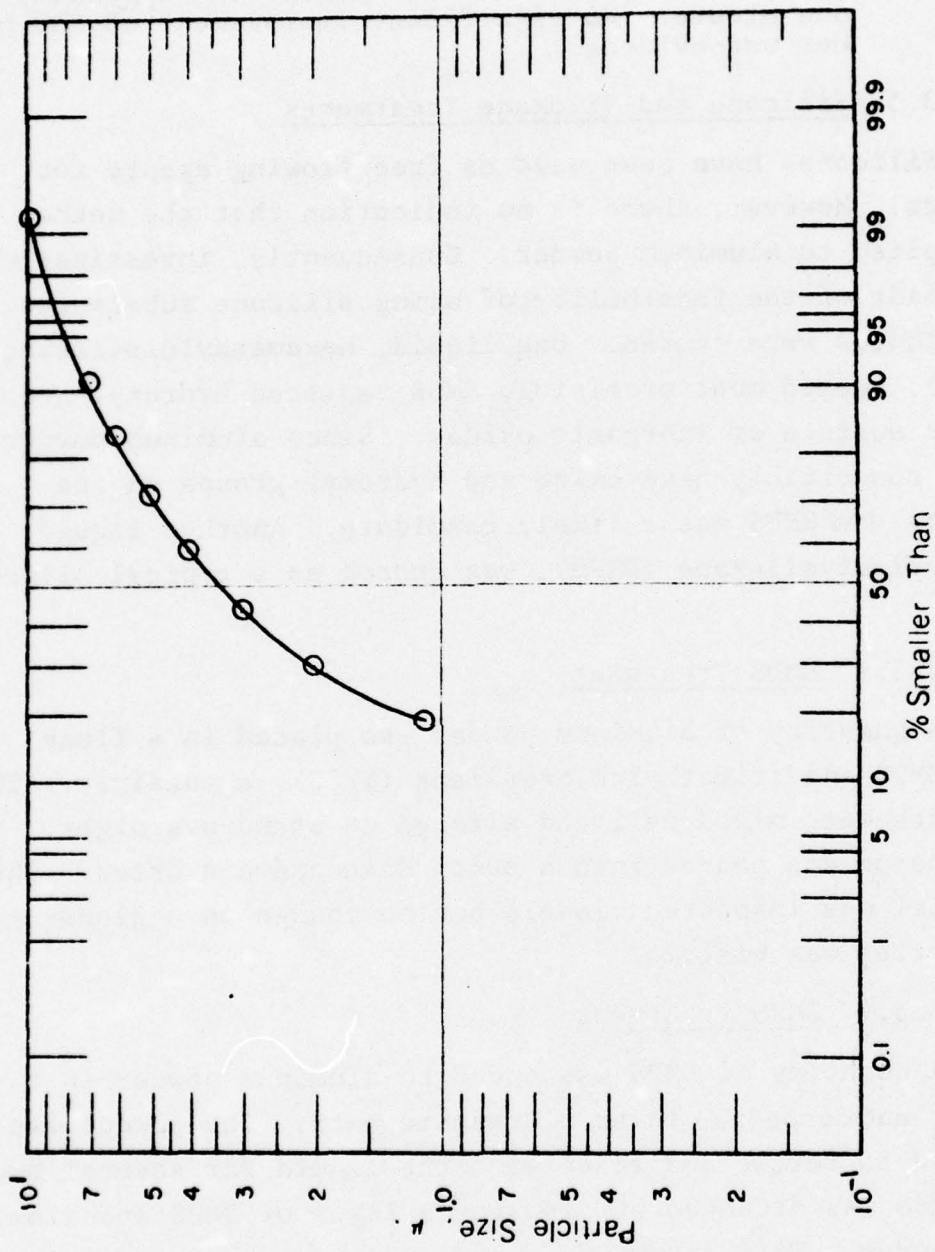

Figure 8

SIZE ANALYSIS OF STEAM TREATED AL POWDER  
BY OPTICAL MICROSCOPY

- (b) Stearic acid and aluminum powder were placed in a mortar and pestle. The mixture was ground for several minutes. Chloroform was added to dissolve any unreacted stearic acid, and the resulting suspension was filtered and washed repeatedly with chloroform. After vacuum drying, this material was ground in a mortar and pestle for approximately one minute. No significant improvement of the powder was evident.

### 3.5 Silicone and Siloxane Treatments

Silicones have been used as free flowing agents for powders. However, there is no indication that the method can be applied to aluminum powder. Consequently, investigations were made of the feasibility of using silicone substances. Two liquids were chosen. One liquid, hexamethyldisilazane (HMDS), seemed most promising. HMDS replaces hydroxyl groups on the surface of inorganic oxides. Since aluminum powder could conceivably have oxide and hydroxyl groups on the surface, the HMDS was a likely candidate. Another liquid, dimethylpolysiloxane (DMPS), was chosen as a typical silicone fluid.

#### 3.5.1 HMDS Treatment

A quantity of aluminum powder was placed in a flask with HMDS and trimethylchlorosilane (TMCS), a catalyst. The contents were mixed well and allowed to stand overnight. The suspension was poured into a petri dish and air dried. The material was inspected closely but no change in agglomeration properties was visible.

#### 3.5.2 DMPS Treatment

A quantity of DMPS was added to aluminum powder in a beaker and dispersed in an ultrasonic bath. The powder was allowed to settle and react with the liquid for several hours. The DMPS was decanted off leaving a layer of DMPS and aluminum powder. This layer was dried under nitrogen gas and ground slightly in mortar and pestle. The substance was examined carefully but no change in agglomeration properties was evident.

### 3.6 Use of Spacer Particles

Fumed silica such as Cab-O-Sil is frequently used as an additive to improve flow properties of powders. Two types of fumed silica were tried. One was Cab-O-Sil, having an average diameter of 7 nm, and the other was Silanox, which is a fumed silica (7 nm) silylated with HMDS (hexamethyl-disilazane). Several different proportions of these additives were tried (Table 1).

The powder and additives were mixed by a spatula and placed on a 200 mesh screen. The powder was collected in a pan below the screen after several tappings. The flowing tendency of the powder was visually examined. Both additives improved the flow property of the powder, and the degree of improvement increased with increasing amounts of the additives upto the maximum amount tried (2% additive). However, the powder treated with Silanox showed better flowing tendency than Cab-O-Sil at the same proportions. Also, some samples were ground in a mortar and pestle after mixing by a spatula. Then the samples were screened. These ground samples had better flowing property than respective unground powders.

### 3.7 Polymer Treatment

The feasibility of coating (encapsulating) the aluminum particles with polymeric material was considered. Two polymers, polyethylene and polystyrene, were used. The polymer was dissolved in toluene or xylenes. Aluminum powder was dispersed in the polymer solution with an ultrasonic probe, and the suspension was atomized through an air-blast nozzle (Figure 9). Samples of the spray after evaporation of solvent were collected and examined under a microscope. The presence of a coating was clearly visible indicating that the thickness of the coating could be reduced. Furthermore, polystyrene coating appeared to be better than polyethylene. Hence different concentrations of aluminum and polystyrene were used to optimize the coating (Table 2). A coating was observed on the particles. 1% Al dispersed in 0.1% polystyrene solution (toluene) appeared to give best results. An electronmicrograph of the powder sprayed with polystyrene is shown in Figure 10.

Table 1

PROPORTION OF SPACER PARTICLE ADDITIVES  
Powder: Al Powder (No. 6-f)

% Spacer	Type
1.0%	Cab-O-Sil
2.0%	Cab-O-Sil
0.5%	Silanox 101
1.0%	Silanox 101
2.0%	Silanox 101

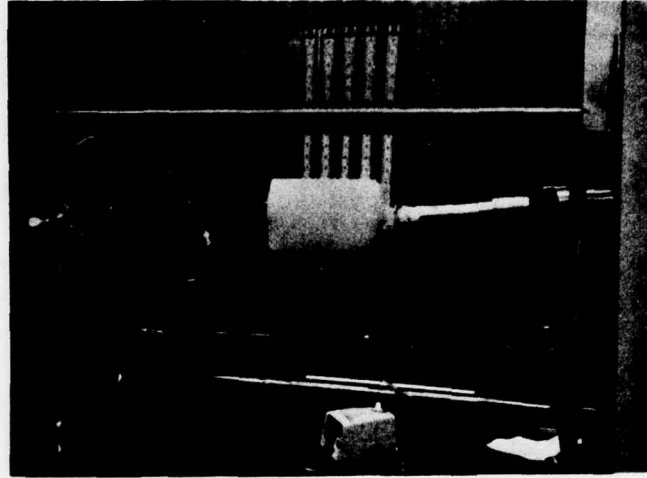

Figure 9

PHOTOGRAPH OF SPRAY SET-UP

Table 2

COMBINATION OF Al POWDER AND POLYMER  
FOR ENCAPSULATION FEASIBILITY

Aluminum Concentration*	Polymer*	Solvent
<1%	Polyethylene (saturated solution)	Xylenes
0.3%	Polyethylene (saturated solution)	Toluene
<1%	Polystyrene (3%)	Carbontetra- chloride
0.05%	Polystyrene (2%)	Xylenes
0.5%	Polystyrene (2%)	Xylenes
0.5%	Polystyrene (0.5%)	Toluene
1%	Polystyrene (0.5%)	Toluene
1%	Polystyrene (0.1%)	Toluene

\* all concentrations are given by weight

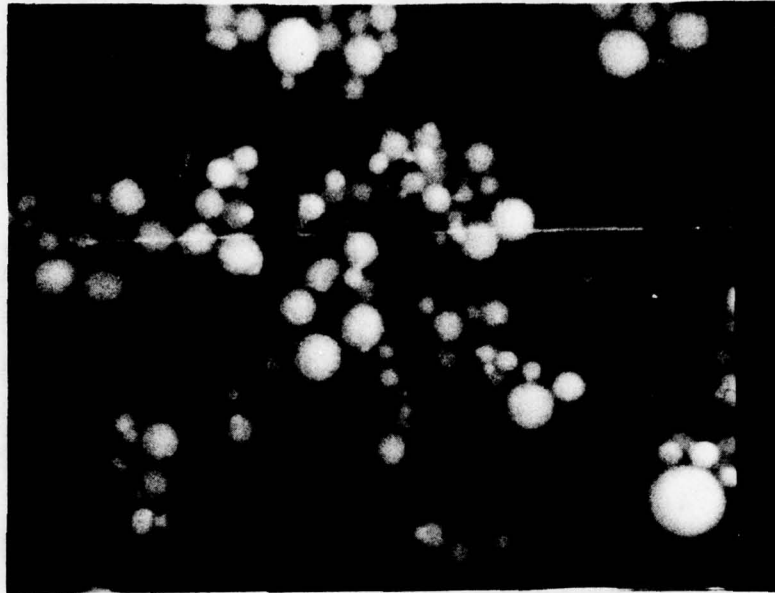

Figure 10

ELECTRONMICROGRAPH OF Al POWDER SPRAYED  
WITH POLYSTYRENE IN SOLVENT

An attempt was made to coat the particles by polymerising styrene monomer on particle surface. Aluminum aerosol and styrene monomer vapor were contacted in a heated pyrex glass tube so that monomer may polymerise on the surface of aluminum.

The polymer coated particles did not exhibit better flow properties than the original powder.

### 3.8 Measurement of the Adhesion Force

A centrifuge technique was used to measure the force of adhesion. The apparatus consisted of a preparative ultracentrifuge capable of a maximum speed of 50,000 rpm. In this apparatus, the force of adhesion between a particle and a flat substrate was studied. The substrate was mounted on the head of a flat hexagonal screw. Particles were deposited on the substrate. Photomicrographs of the particles deposited on the substrate were taken and the screw was mounted on the insert shown in Figure 11. An even number of inserts were placed (diagonally arranged) in a centrifuge rotor (Figure 12) in such a way that the substrate was parallel to the rotation axis and facing outwards. The centrifuge chamber was evacuated and the rotor was spun at the desired speed for approximately 2 minutes and slowly decelerated to a complete stop. The screws were removed and photomicrographs of particles were taken again. The number of particles removed were determined by visual comparison of the photomicrographs taken before and after centrifugation.

The centrifugal force  $F$ , applied to a particle of size  $dp$  is given by

$$F = \text{mass} \times \text{acceleration}$$
$$= \frac{\pi dp^3}{6} \cdot \rho_p \cdot \frac{(2\pi n)^2 R}{3600} \cdot 981 \text{ dynes}$$

where  $n$  is the number of revolutions per minute,  $R$  is the radial distance between the particle and the axis of rotation, and  $\rho_p$  is the density of the particles.

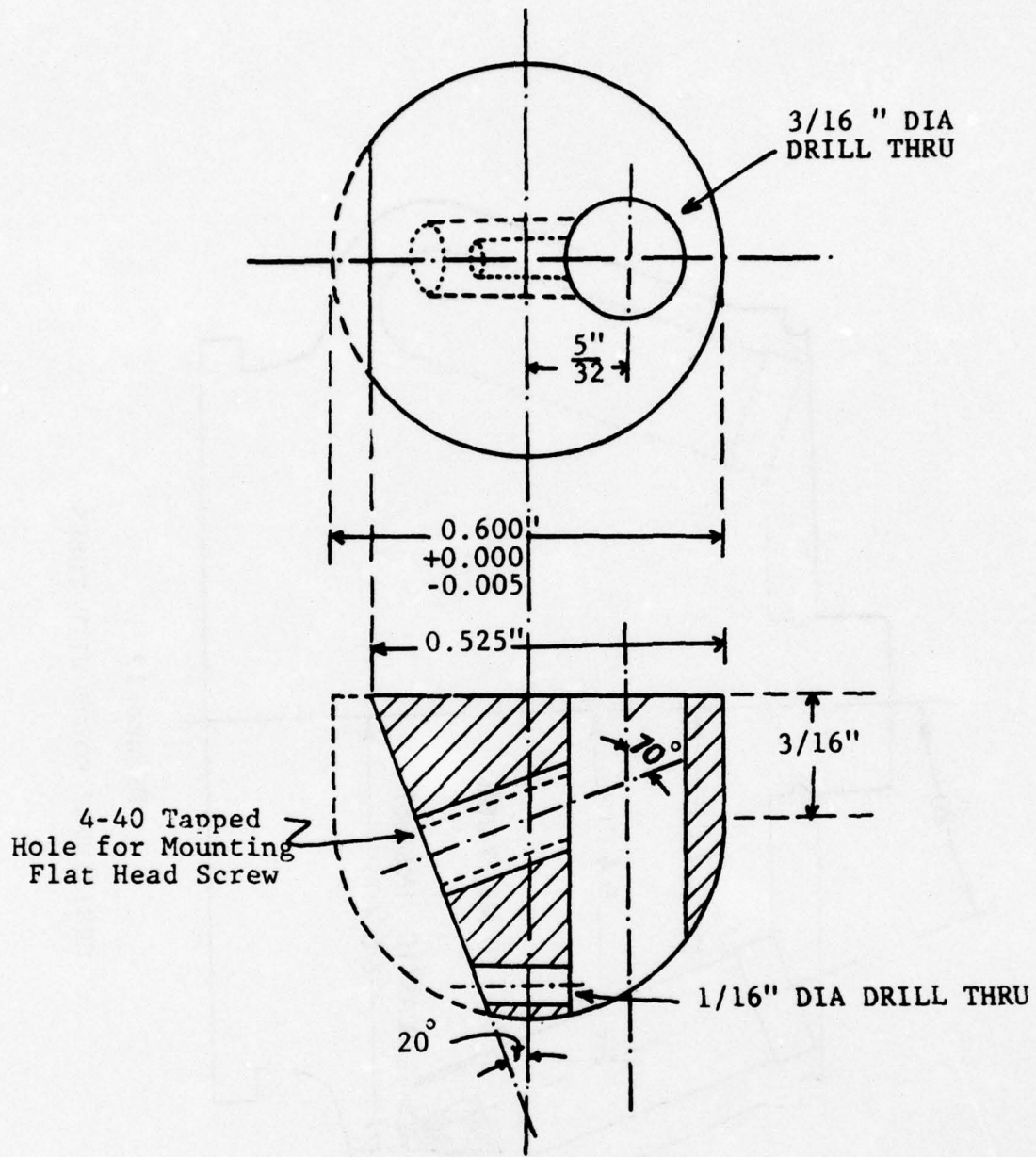

Figure 11  
CENTRIFUGE INSERT

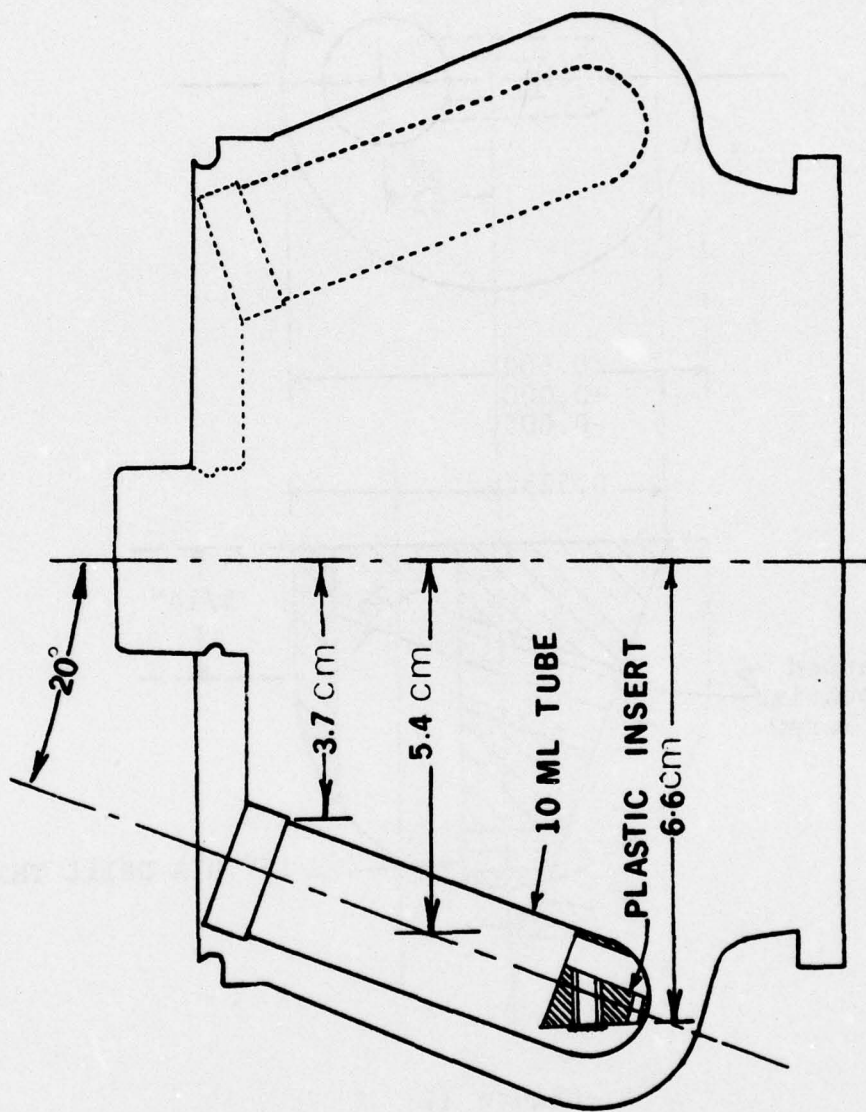

Figure 12  
CENTRIFUGE ROTOR WITH TUBES

A list of particles and substrates used in experiments are presented in Table 3. Powder 6-C was always used for these adhesion experiments. The aluminum powder was deposited on substrate from a flowing aerosol, whereas treated powder was deposited on substrate in a vacuum chamber.

Due to the statistical distribution of contact areas of the deposited particles, the adhesion force is represented by the value of the applied force necessary to remove fifty percent of the total particle number on the substrate (1).

At the highest force level that could be achieved, less than 50% of the particles were removed in most of the experiments. However, useful information can be obtained by comparing the percentage of particles removed at the maximum applied force at 50,000 rpm. The presence of the polymer film between the aluminum particles and the substrate generally accomplished higher percent removal of particles. Thickness of the intermediate film also had an effect on the percent removal; being larger for the thicker film.

We used polystyrene and nylon spheres on similar substrates, and no removal was achieved at 50,000 rpm. These results indicated that the polymer coating on aluminum will not improve the dispersion properties.

The water treated Al particles on a similar substrate were significantly removed at 25,000 rpm and were completely removed at 50,000 rpm, indicating a significant improvement. The steam treated Al powder also showed a large improvement over the untreated powder. The applied force was in excess of that for 50% removal of the particles.

Also in Table 3, the values of the van der Waals constants are presented along with the calculated force of adhesion based on a distance of separation of  $4\text{\AA}$ . The theoretical force for Al-Al system for the van der Waals interaction (Eq 1) as well as the electrical forces arising from contact potential charging (Eq 2) are also given as a function of the distance of separation

Table 3  
ADHESION MEASUREMENT IN AIR

Powder	Substrate	Speed	Applied Force* (dynes)	% Particles Removed	Hamaker Constant $A \times 10^{12}$ (ergs)	$F_{ad}^{**}$ (dynes)
Al	Al	50,000	$3.2 \times 10^{-2}$	5.2	3.4	$2.7 \times 10^{-3}$
Al	Polystyrene film on Al	50,000	$3.2 \times 10^{-2}$	25.8	0.92	$7.3 \times 10^{-4}$
Al	Nylon Film on Al (thin)	50,000	$3.2 \times 10^{-2}$	11.7		
Al	Nylon Film on Al (thick)	50,000	$3.2 \times 10^{-2}$	20.4		
Polystyrene	Polystyrene	50,000	$\sim 2 \times 10^{-2}$	0		
Nylon	Nylon	50,000	$\sim 2 \times 10^{-2}$	0		$1.9 \times 10^{-4}$
Water Treated Al	Water Treated Al	25,000	$0.8 \times 10^{-2}$	88.0		
Al	Al	50,000	$3.2 \times 10^{-2}$	100.0	$\sim 3.0$	$2.6 \times 10^{-3}$
Steam Treated Al	Steam Treated Al	50,000	$3.2 \times 10^{-2}$	85.0	$\sim 3.0$	$2.6 \times 10^{-3}$

\* Based on 5  $\mu$ m particle size

# Theoretical force at a distance of separation of 0.4 nm

$Z_0$  and two particle sizes in Figure 13. At a distance of  $4\text{\AA}$ , two  $5\ \mu\text{m}$  Aluminum spheres are attracted by a force of  $\sim 3 \times 10^{-3}$  dynes contributed by the van der Waals interactions, while the electrical effects contribute  $4 \times 10^{-4}$  dynes. As seen from the Figure 13, the electrical forces are considerably smaller until the distances of separation  $Z_0$  is large ( $\sim 2\ \text{nm}$ ).

Comparison of experimental data with the van der Waals forces could be made by realizing that the adhesive forces for a system is the value of the force required for fifty percent removal of particles. For the Al - Al system, at an applied force of  $3.2 \times 10^{-2}$  dynes, only 5% of the particles are removed. Similarly, the values of the percent removal of particles for the Al-Polymer and Polymer-Polymer systems are quite low. However, more than fifty percent of the particles were removed for the steam treated and the water treated powder, indicating better agreement between the experimental results and the van der Waals force.

A possible explanation for these observations may be attributed to the relative hardness of these materials. The aluminum metal and the polymer materials are softer and may flatten at the point of contact. This would result in a higher force of adhesion than the force calculated by Equation which assumes that no deformation of the surface takes place. Krupp (2) has presented some calculations (Table 4) showing that the adhesion force could be increased due to deformation of the particle and the substrate.

On the water treated powder,  $\alpha$ -alumina trihydrate ( $\text{Al}[\text{OH}]_3$ , Bayerite) was observed (Section 3.2). While no such layer was detected on the steam treated powder, a thin layer of the bayerite may be present which may not be detected by the x-ray powder diffraction technique. The increase in the specific surface area as observed by the nitrogen absorption (Section 3.3) indicates transformation of the surface.

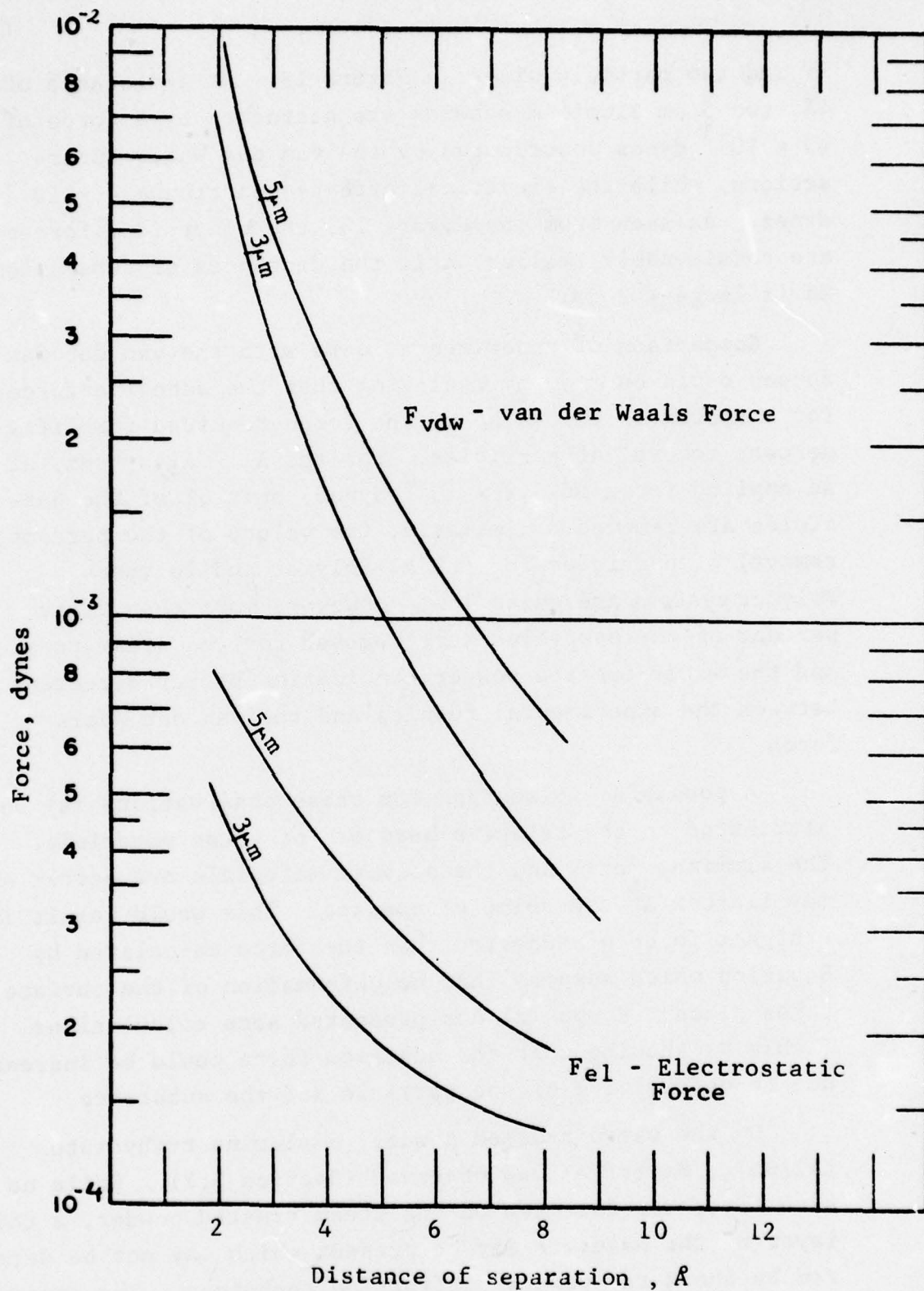

Figure 13

FORCES OF ATTRACTION BETWEEN AN ALUMINUM SPHERE AND  
A FLAT ALUMINUM PLATE

Table 4

EFFECT OF HARDNESS ON VAN DER WAALS ADHESIVE FORCE  
 BETWEEN A 5  $\mu\text{m}$  DIAMETER SPHERE AND A FLAT  
 SURFACE AT A SEPARATION OF .4 nm\*

Hardness H (dynes/cm <sup>2</sup> )	Hamaker Constant A x 10 <sup>12</sup> (ergs)			
		0.29	0.96	4.31
10 <sup>6</sup> (Plastics) F <sub>ad</sub> →	3600	4 x 10 <sup>4</sup>	-	
10 <sup>8</sup> (Metals) (mdynes)	42	400	8 x 10 <sup>3</sup>	
10 <sup>10</sup> (Abrasives)	6	24	170	

\* from Krupp (2), page 195

The Vickers microhardness of a high purity Aluminum piece was measured using Leitz microhardness tester. Then, the surface of the aluminum piece was exposed to steam for about 30 minutes and the microhardness of this reacted surface was remeasured in an attempt to assess changes in surface characteristics. No difference in the hardness was found, possibly because the steam did not reach the aluminum up to the required depth for the measurement which is estimated to be approximately 10 microns.

No information on the hardness of Bayerite ( $\text{Al}[\text{OH}]_3$ ) was found in literature. Further work is needed to check the validity of the contribution of the hardness to the force of adhesion.

### 3.9 Tensile Strength Measurement

Agglomerating tendency of particles is related to the strength of a powder bed. The tensile strength of a powder is closely related to its agglomeration properties. The greater the agglomerating tendency, the greater is its tensile strength.

A common device used by powder technologists for the measurement of tensile strength is the cell shown in Figure 14. To determine the strength of powder, the two halves of the test cell are filled with powder, which is leveled to a desired height. A force on the free half is applied and increased gradually until the powder bed is broken. One way for applying gradually increasing force is to mount the free half on wheels on a track and incline the whole cell until the free half rolls off. At this point, the weight of the broken half and the angle at which separation occurs is determined and the tensile strength is calculated.

This device is suitable for testing small volumes of samples in a vacuum. We fabricated this cell (Figure 15). The inclination was provided by a motor and a gear reduction system. The inclination rate was  $9^\circ/\text{minute}$ . The tensile strength was calculated by the following formula

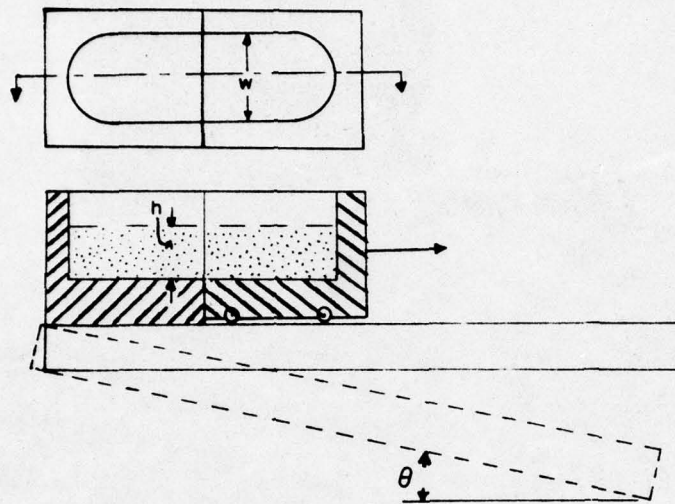

Figure 14

APPARATUS FOR MEASUREMENT OF TENSILE  
STRENGTH OF POWDERS

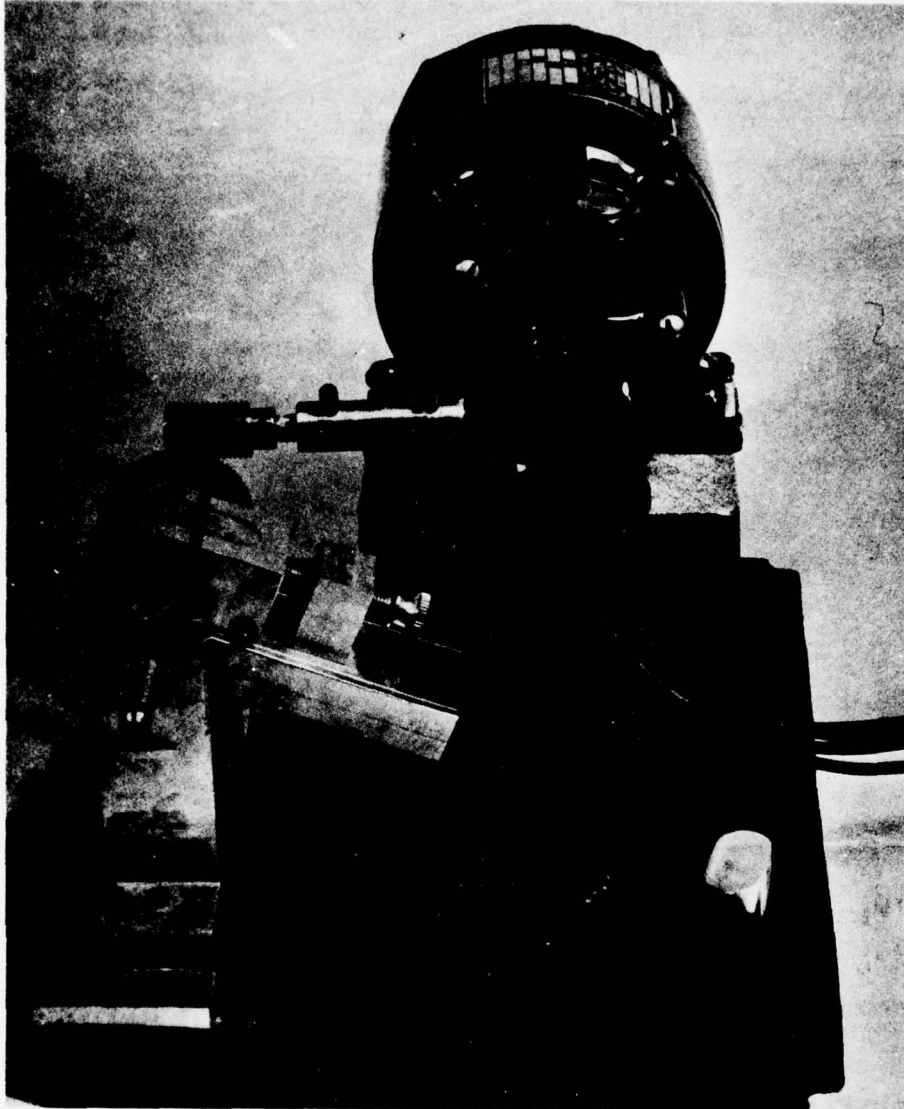

Figure 15

PHOTOGRAPH OF TENSILE STRENGTH MEASUREMENT CELL

$$\sigma_t = \frac{m \cdot g \cdot \sin \theta}{g_c \cdot h \cdot w}$$

where

- $\sigma_t$  = tensile strength, dynes/cm<sup>2</sup>
- m = mass of the separated half, gm
- g = gravitational acceleration, 980.6 cm/sec<sup>2</sup>
- $\theta$  = angle of inclination (Figure 14)
- $g_c$  = 1 gm - cm/dynes - sec<sup>2</sup>
- h = height of sample bed, cm
- w = width of sample bed, cm

$\sin \theta$  was measured by measuring the distance P as shown in Figure 16, using a cathetometer.

Precautions were taken to achieve frictionless motion of the wheels. The weight of the powder filled, and the height of the powder bed were also kept practically constant. The laboratory humidity for all the measurements was  $50 \pm 5\%$ . The results are summarized in Table 5. All the runs were performed in duplicate and they were within  $\pm 5\%$  of the reported values in the Table 5, except for the untreated powder (which was 11%, probably due to high agglomeration of the particles.) The tensile strength was highest (5048 dynes/cm<sup>2</sup>) for untreated powder, whereas steam treated powder had the lowest tensile strength (1707 dynes/cm<sup>2</sup>) and therefore lowest tendency to agglomerate. Polymer coating and water treatment did not seem to provide any significant deagglomeration tendency to the powder particles.

The tensile strength model by Rumpf relates the van der Waals forces to the tensile strength in a powder by

$$\sigma_z = (A/24) (d/a^2)$$

where A is the Hamaker constant, a is the distance between spheres and d is the diameter of spheres. The relationship is dependent on the porosity of the bed and the size distri-

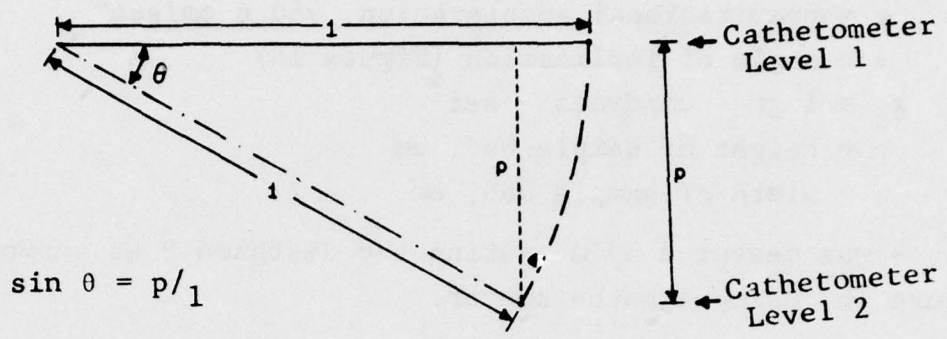

Figure 16

ANGLE MEASUREMENT FOR TENSILE STRENGTH  
DETERMINATION

Table 5

TENSILE STRENGTH MEASUREMENT  
Weight of Powder in Each Run  $\approx$  24.6 gm

---

Run Number	Powder	Tensile Strength (dynes/cm <sup>2</sup> )
T1	Untreated	5048
T2	Polystyrene Coated	4101
T3	0.5% Silanox Treated	3316
T4	2% Cab-O-Sil Treated	2923
T5	Water Treated	4201
T6	Steam Treated	1707

---

bution of the particles. On a qualitative basis, however, the relationship predicts that the tensile strength is proportional to the van der Waals force between the particles. The tensile strength data follows the values of the adhesion force as measured by the centrifuge method.

### 3.10 Powder Release in Vacuum

An apparatus for release of particles in a vacuum without mechanical dispersion aids was needed to evaluate the effectiveness of the powder treatment. We designed the apparatus shown in Figure 17. Powder was placed in a 5/8 in. diameter cylindrical cavity and flattened with a small cylindrical rod. Vacuum in the bell jar was established to about  $5 \times 10^{-4}$  Torr. The solenoid was actuated and the powder fell in the petri dish below. Visual examination of the powder in the dish indicated the effect on dispersion of powder in qualitative manner. In Figure 18 (a,b,c,d,) photographs of powders released in the apparatus are presented. (The same mass [0.6gm] of powder was used in each experiment).

A redesign of the release test was necessary to assess the effectiveness of the treatment quantitatively. Also, release height was not sufficient in the above apparatus. Hence, another apparatus for dispersing powders was designed and fabricated (Figure 19). This was similar to above apparatus except that that it was bigger, and that the sample cell was sealed from the surroundings so that a known small pressure can be applied to the powder. The powder is released by energizing the solenoid valve. Table 6 lists all the powders tested for release in this apparatus. A fixed amount of powder (0.6gm) was used in each experiment. The release height was 16 inches. The pressure maintained in the sample cell was 200 microns Hg. The powder was released when the pressure in the vacuum chamber dropped below a micron. Photographs of released powders are given in Figure 20. The powder treated with spacer particles visually looked like a good flowing powder but, suprisingly , did not disperse well when released through the apparatus. This indicated that although the flow properties, which are dependent on shear strength, were improved, the tensile strength is equally or more important for good dispersion. Cover slides were placed at 2", 4", and 6"

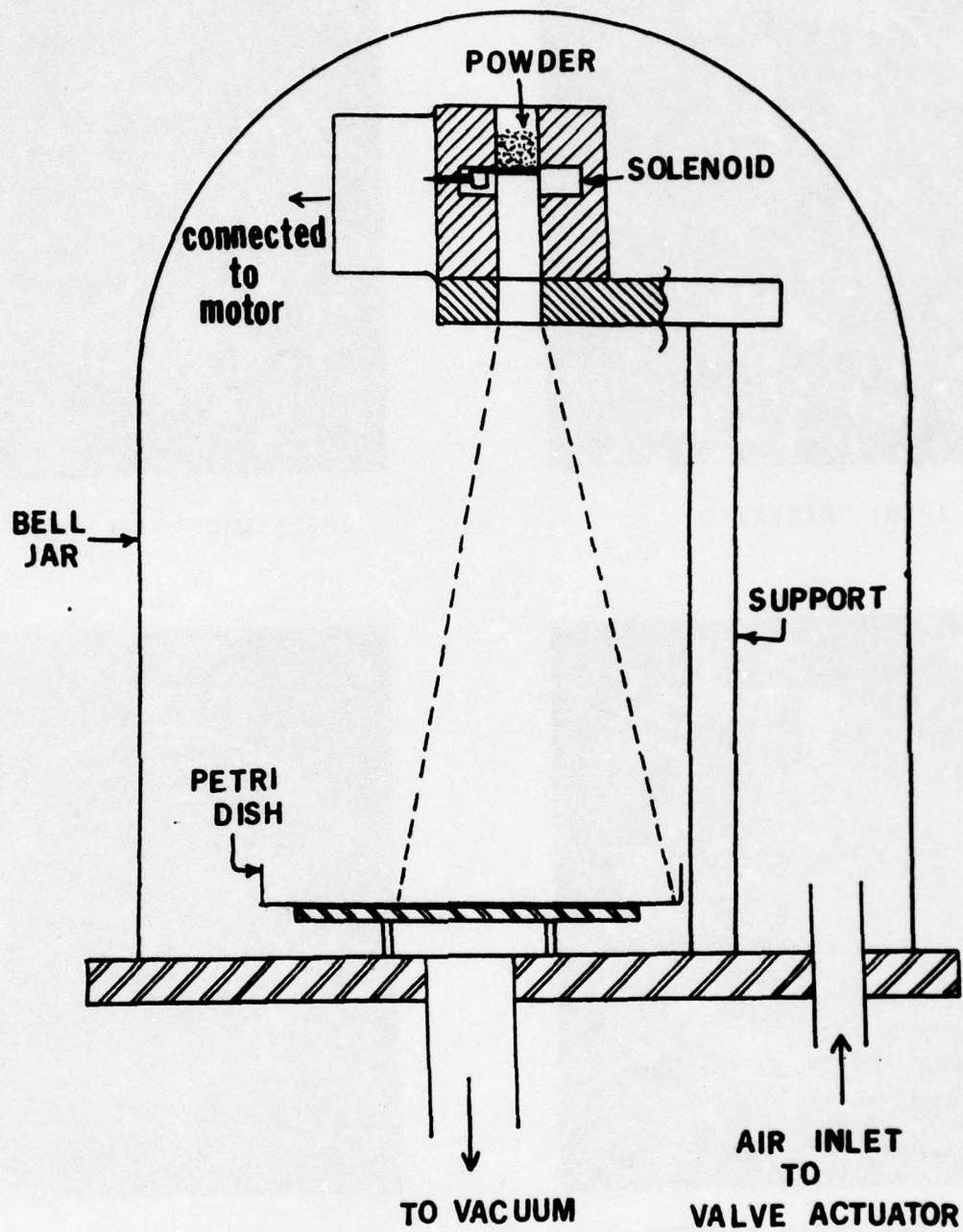
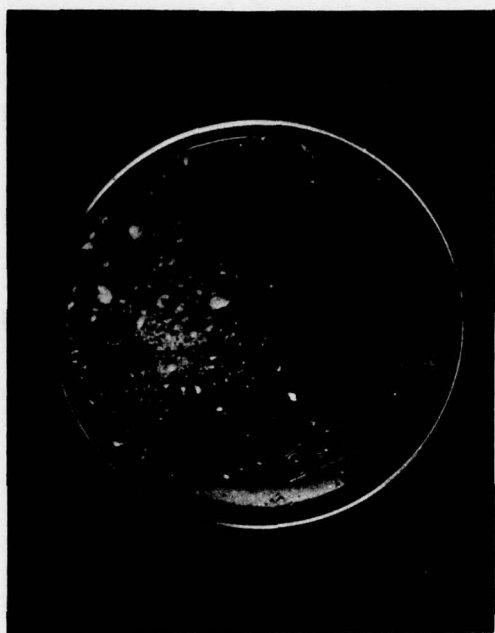
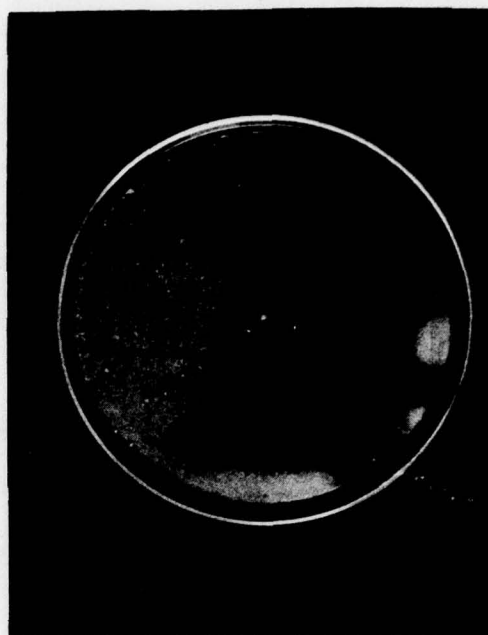

Figure 17  
 APPARATUS FOR RELEASE OF POWDER IN VACUUM



18(a) UNTREATED



18(b) WATER TREATED



18(c) STEAM TREATED



18(d) SILANOX (2%) TREATED

Figure 18

PHOTOGRAPHS OF POWDER RELEASED IN VACUUM

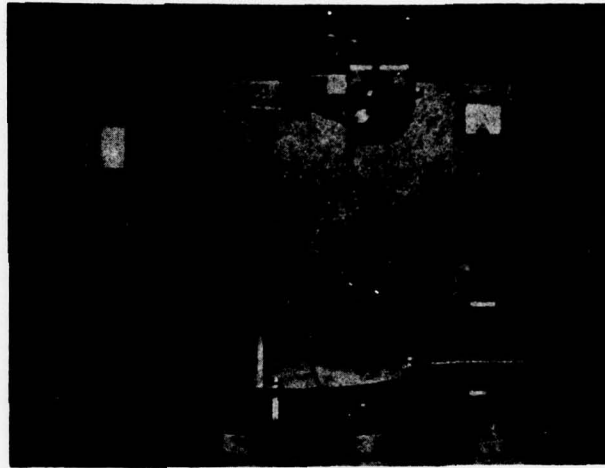
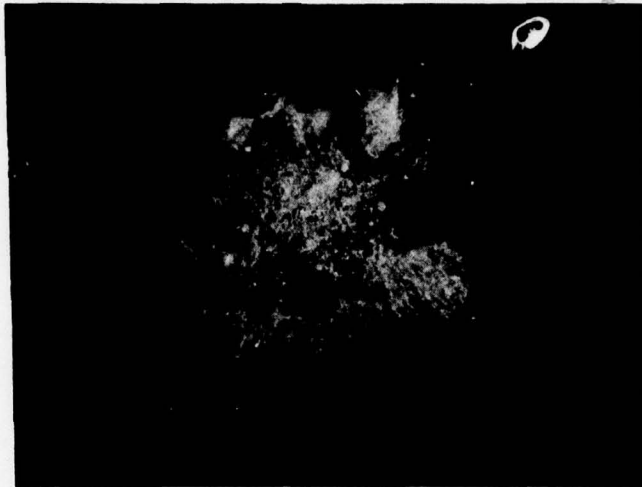

Figure 19  
PHOTOGRAPH OF POWDER RELEASE APPARATUS

Table 6

## TYPE OF POWDERS RELEASED IN VACUUM

Experiment I.D.	Type of Powder
DA	Original Powder
DB	2% Cab-O-Sil Treated
DC	2% Silanox Treated
DD	Water Treated
DE	Steam Treated
DF	Steam + NH <sub>3</sub> Treated



20(a) UNTREATED

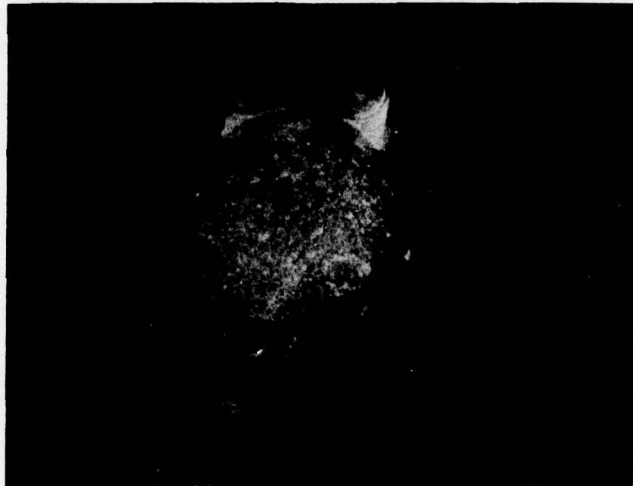

20(b) CAB-O-SIL (2%) TREATED

Figure 20  
PHOTOGRAPHS OF POWDER RELEASED IN VACUUM



20(c) SILANOX (2%) TREATED



20(d) WATER TREATED

Figure 20 (Continued)

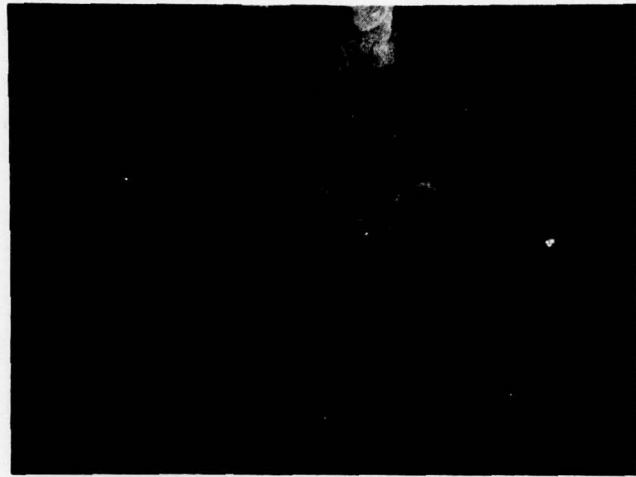

20(e) STEAM TREATED

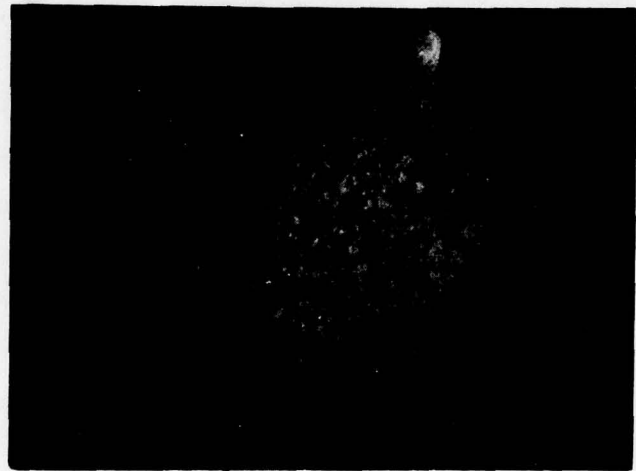

20(f) STEAM AMMONIA TREATED

Figure 20 (Continued)

away from center, and at 0°, 30°, and 60° (Figure 21) for getting samples for size analysis.

Particle size analysis of the samples was carried out by an optical microscope interfaced with an image analyzing computer (Imanco). The size distribution and the number density of the particles at a given position may be conveniently utilized to characterize the dispersibility of the powder.

Differential size distribution of some samples of released original powder is given in Table 7. The last two numerical digits in the sample number refer to the location (where the sample was taken) shown in Figure 21. The table clearly indicated the presence of many agglomerates and a very poor dispersion. Also, particle density is very low at 4" distance. At 6" distance, the density was negligible and hence no size analysis was done.

Size distribution of water treated powder is given in Table 8. The area covered by particles at 2" and 4" distance was too large (more than 28%) and hence their size distribution analysis was not done. The dispersion was very good. However, the data shows that several big agglomerates were present.

Table 9 gives differential size distribution of steam treated powder. The dispersion was very good and a very few agglomerates were present. Hence, this treatment appears to be the best. This experiment was repeated and a good reproducibility was obtained.

The size distributions were plotted on a log-probability graph. A straight line relationship was obtained indicating a log-normal distribution. Figure 22 shows a typical size distribution of original powder and steam treated powder at two same locations. Similarly, Figure 23 shows size distribution of water treated and steam treated powders at two locations.

No size analysis of powder treated with spacer particles was done since the powder did not disperse well laterally. The particle density on the deposit was consequently too high to allow resolution of single particles.

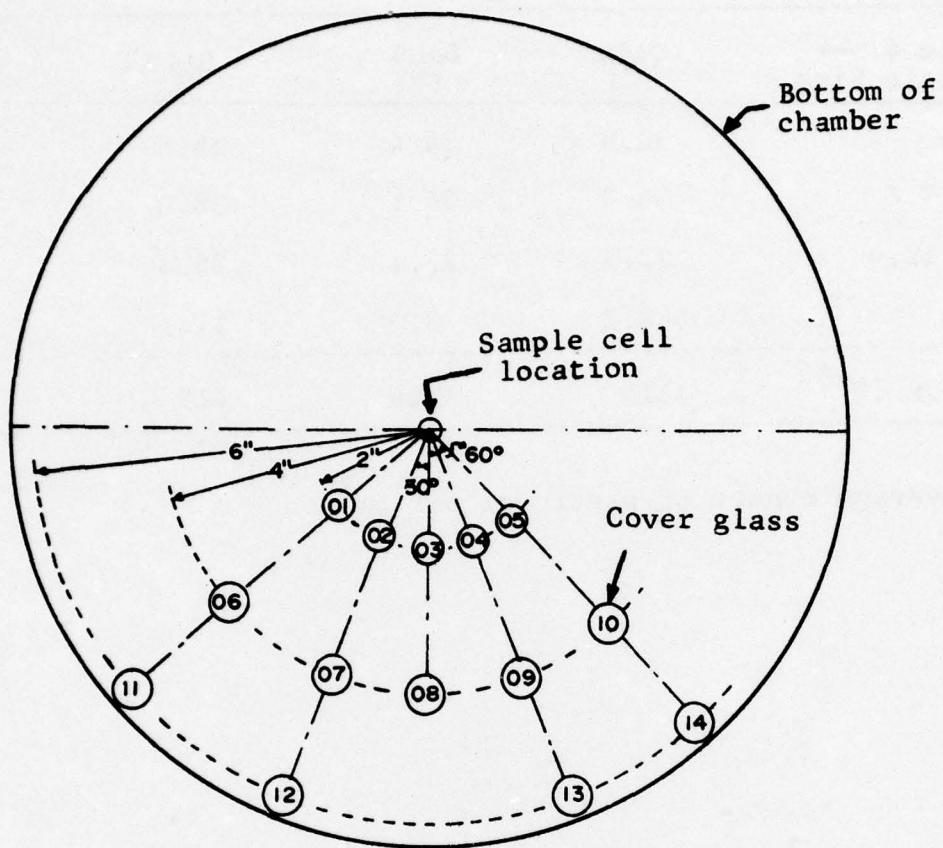

Figure 21

SAMPLE LOCATIONS IN VACUUM RELEASE APPARATUS

Table 7  
 SIZE DISTRIBUTION OF THE VACUUM RELEASED ORIGINAL  
 POWDER AT DIFFERENT LOCATIONS

Sample # → Particle Size	DA08 (%)	DA09 (%)	DA10 (%)
<4.3 μ	32.8	34.4	25.6
4.3 - 7.6	36.8	34.1	38.0
7.6 - 12.4	22.3	23.1	25.3
>12.4	8.2	8.5	11.1
N* x 10 <sup>-3</sup>	315	266	415

\* Average number of particles per cm<sup>2</sup>

Table 8  
 SIZE DISTRIBUTION OF THE VACUUM RELEASED WATER  
 TREATED POWDER AT DIFFERENT LOCATIONS

Sample # →	<u>DD11</u>	<u>DD12</u>	<u>DD13</u>	<u>DD14</u>
Particle Size ↓	(%)	(%)	(%)	(%)
<4.3 μ	69.06	67.27	62.10	56.14
4.3 -7.6	13.55	12.99	16.11	18.30
7.6 -12.4	8.59	7.99	10.06	11.91
12.4-17.3	4.22	4.51	4.80	5.98
17.3-24.9	2.80	3.46	3.92	4.36
24.9-34.1	1.22	2.20	1.94	1.06
>34.1	0.57	1.60	1.85	1.45
N* x 10 <sup>-3</sup>	1445	967	750	686
A†	20.2	23.6	19.7	20.8

\* Number of Particles per cm<sup>2</sup>

† % Area covered by particles

Table 9  
 SIZE DISTRIBUTION OF THE VACUUM RELEASED STEAM  
 TREATED POWDER AT DIFFERENT LOCATIONS

Particle Size →	<u>&lt;4.3<sub>μ</sub></u>	<u>4.3-7.6</u>	<u>7.6-12.4</u>	<u>&gt;12.4</u>	<u>N*x10<sup>-3</sup></u>	<u>A†</u>
Sample # ↓	(%)	(%)	(%)	(%)		(%)
RG06	68.36	18.19	8.85	4.60	1918	18.05
RG07	68.16	19.55	8.16	3.82	1546	14.46
RG08	66.52	20.25	9.32	3.90	1399	14.24
RG09	67.53	19.70	8.51	4.25	1718	16.33
RG10	67.06	20.70	8.34	3.89	1431	14.05
RG11	72.22	18.30	7.09	2.39	1524	11.08
RG12	73.54	17.99	6.51	1.96	1108	10.18
RG13	79.26	15.21	4.29	1.23	1307	9.19
RG14	16.48	16.13	5.93	1.46	1213	11.37

\* Number of Particles per cm<sup>2</sup>  
 † % Area covered by particles

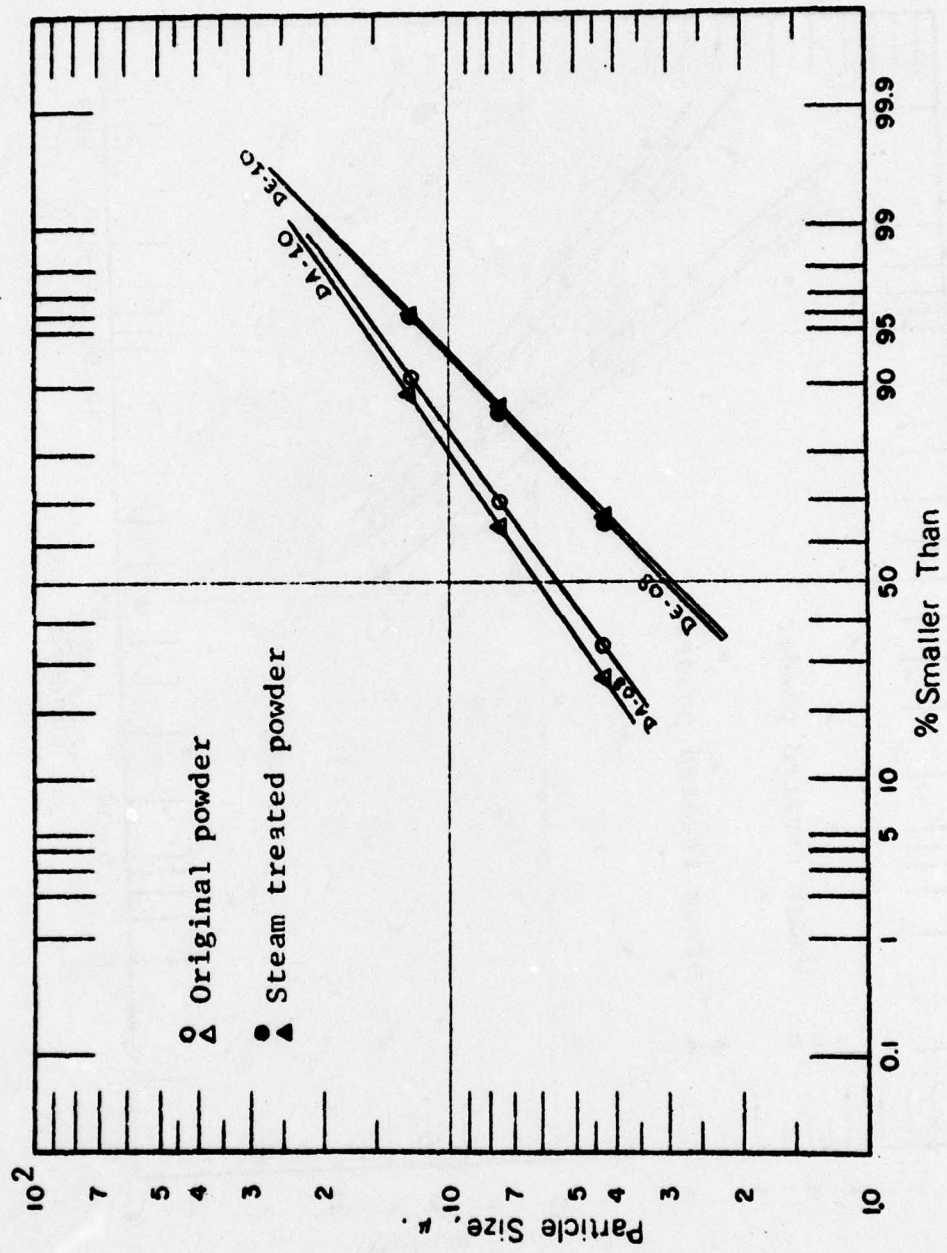

Figure 22

SIZE DISTRIBUTION OF THE VACUUM RELEASED POWDER AT DIFFERENT LOCATIONS

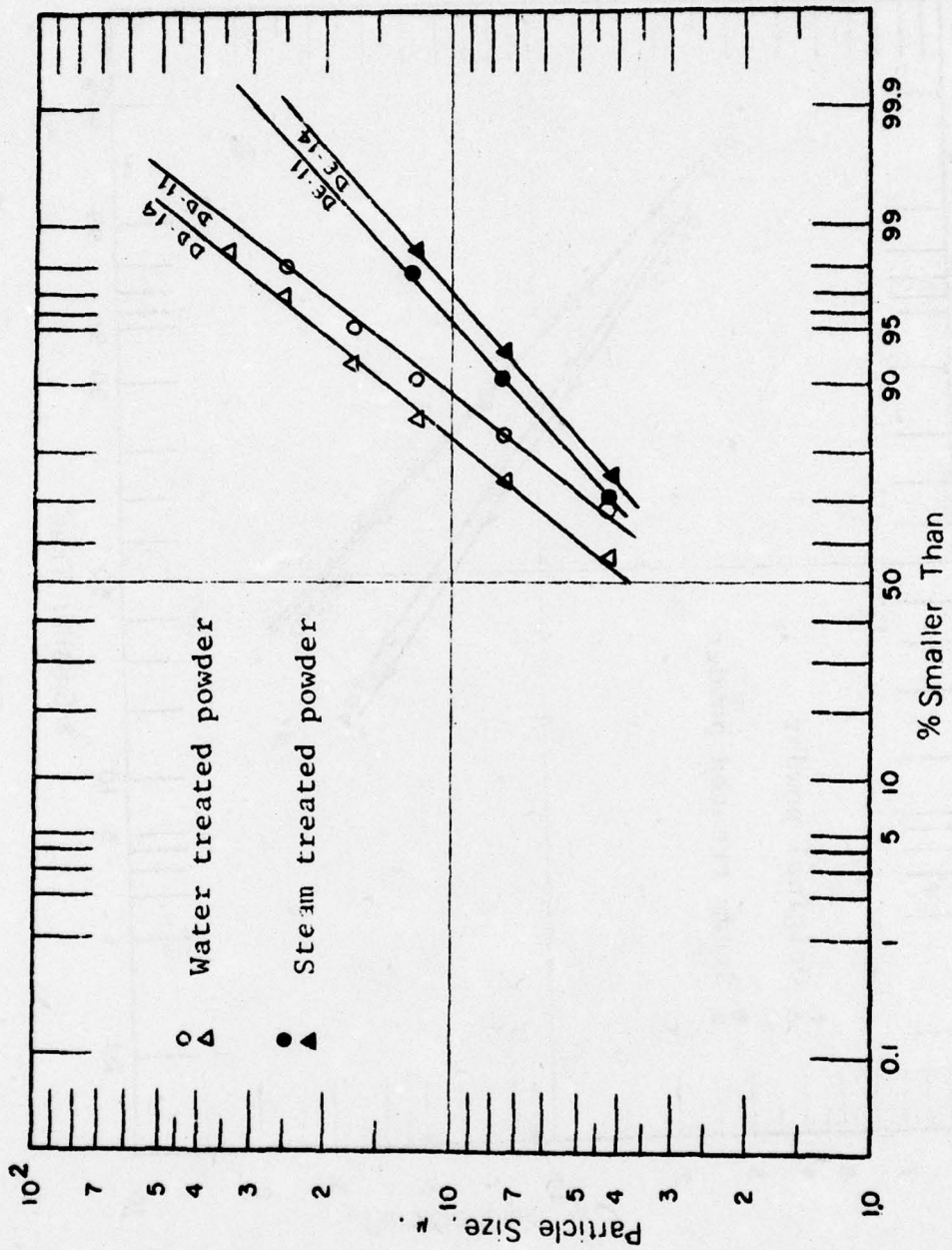

Figure 23

SIZE DISTRIBUTION OF THE VACUUM RELEASED POWDER AT DIFFERENT LOCATIONS

#### 4. DISCUSSION OF RESULTS

Agglomeration properties of micron sized powders depend on the various physical, chemical and mechanical properties of the powder material. When two powder particles are in contact with each other, attractive forces between them act across the contact interface to hold them together. In a bulk powder system, these attractive forces are transmitted over all of the particles, resulting in cohesion of the powder. The mechanical properties of the bulk powder such as the shear strength, tensile strength, and elasticity are affected by the magnitude of the interparticle forces, particle size, packing and the contact area of the particles.

The interparticle forces are quantitatively predictable only for ideal microscopic systems such as two spheres or a sphere and a flat plate. The actual interfacial contact area of the particles and the distance of separation (even at a close contact the minimum distance between particles may vary from 4 to 2 nm) play an important role in the real systems. Experimental verification of the microscopic theoretical forces such as van der Waals interaction and electrostatic forces is possible only by a qualitative comparison of the experimental results and trends with the theoretical predictions.

Measurement of adhesion between the various powder and substrate systems (Section 3.8) show some remarkable results. The raw aluminum powder shows a much higher adhesion than predicted by the theory based on an ideal sphere and a plane substrate. This may be attributed to the true contact area between the particles being several times more than the ideal sphere and plate model. Presence of an oxide layer on the aluminum has very little effect on the theoretical predictions. The deviations are therefore dependent of the deformability of the contact interface, which is related to the hardness of the material. Results for the various powder and substrate systems in Table 3 indicate validity of this hypothesis. For the raw powder, the natural oxide layer, which lacks order

and continuity, does not affect the hardness of the soft aluminum. As seen in Table 4, an order of magnitude difference in the force may be expected between an abrasive surface (ideal sphere) and a deformable metal surface.

Results with aluminum particles on polystyrene show the effect of the reduced value of the Hamaker constant. Results with nylon show that the Al-Al interaction across the thin film may be present although somewhat shielded. Results with polymer particles and polymer substrates show high adhesion. The steam and water treated powder systems show good agreement with the theoretical predictions.

The adhesion measurements indicate that the steam and water treatment which promote hardness will result in better dispersing powders while polymer coating may actually increase agglomeration.

One mechanical property of a bulk powder is its tensile strength and is related qualitatively to the microscopic interparticle force as shown by Rumpf (9). Our results shown in Table 5 indicate that the tensile strength of powders were in the same general order as the measured force of adhesion. The raw powder and polystyrene coated powder show high tensile strength compared to the steam treated powder. The powder treated with up to 2 percent of Cab-O-Sil and Silanox showed moderately high tensile strength despite excellent apparent flowability. The water treated powder also showed high tensile strength but low adhesion. This may be attributed to the change from a spherical to an irregular shape (Figure 4).

The dispersion experiments show (Tables 7-9, Figures 20-23) that raw powder dispersed poorly. Addition of up to 2% Cab-O-Sil and Silanox noticeably improved flow properties but did not decrease the effect of the interparticle forces. As a result, the powder flowed out like a plug without lateral dispersion. The water and steam treated powder behaved well in these experiments.

Based on these considerations, evaluation of the treatment is made below. The criteria for the successful treatment are good dispersibility and minimum change in the particles.

The water treatment was tried as an intermediate step in the HMDS treatment. The dispersion properties of the water treated powder are excellent. On the other hand, the powder shape and size distribution is altered by complete conversion to bayerite and the sintering of several particles (Figure 4). These changes in the properties may be undesirable in the end use of the powder.

The steam treated powder also shows excellent dispersion properties as well as preservation of the shape of the powder particles. Optical and electron microscopy revealed no detectable changes in size and morphology. The high specific surface area is due to an active oxide layer which is porous with interstices of molecular dimensions. The adhesion and tensile strength measurements also showed significant reduction in the attractive forces. The steam treated aluminum powder is the best powder resulting from this program.

The stearic acid treatment did not produce a powder with any visible signs of improvement over the original powder and was not subjected to further evaluation. Same fate was accorded to the silicone and siloxane treatments. Both of the HMDS and DMPS treatments did not alter the visible agglomerating properties of the raw powder. These treatments, when applied to a water treated particle did not noticeably alter the properties above and beyond the improvement obtained by the water treatment alone.

Addition of the spacer particles such as the Cab-O-Sil and Siloxane to the raw aluminum powder was tried since these agents are known to improve flow properties of powders. Our results show that although the flowability was improved significantly,

the dispersion characteristics were not improved. The improvement in flowability increased with increased amounts of Cab-O-Sil and Silanox (up to 2% agents in the raw powder) were tried. The small spacer particles probably act as ball bearings under shear but do not block the interfacial forces.

The spacer particles in the powder may be undesirable for the end use if their presence may alter the desired features of the aluminum powder.

The polymer coating of the aluminum powder was shown to be feasible. The systems were chosen to reduce the van der Waals attraction, due to their low Hamaker constants (Table 3). However, as seen in Table 3, the adhesion force actually increased probably due to the soft nature of the polystyrene and nylon. Electrostatic forces which were negligible in comparison to the van der Waals forces (Figure 13) for the raw aluminum powder may also become significant for the polymer coated systems.

In summary, the results of the experimental work show that the steam treatment produces a powder which is easily dispersible and preserves the shape and size characteristics of the particles. Based on these criteria the steam treatment gives the best results. A full understanding of the reactions and mechanisms will be possible only after further work concentrating on the steam treatment.

## 5. CONCLUSIONS AND RECOMMENDATIONS

The raw aluminum powder is difficult to disperse into individual micron sized particles in air or vacuum. Under this program, research effort was aimed at finding the causes for the agglomerating tendency, and to find ways to improve the dispersion properties. Significant conclusions from this study are listed below:

1. The survey of existing literature indicated that van der Waals attractive forces were responsible for the agglomerative tendency of the powder.
2. Experimental determinations of the force of adhesion of the raw powder showed higher values of adhesive force than calculated from theory. This discrepancy may be due to deformation of the relatively soft aluminum metal at the contact.
3. Silicones and silylation treatments did not improve the dispersion properties of the powder. Stearic acid treatment also proved unsuccessful.
4. Encapsulation of the powder with polystyrene and polyethylene was shown to be feasible but did not improve dispersion properties. Experimental adhesion force values show that the deformation of particles on contact may contribute to the higher than the theoretical van der Waals force of adhesion for plastics.
5. Treatment with flow-aid agents such as Cab-O-Sil and Silanox increased the flowability of the powder, but the dispersion characteristics were only slightly improved.
6. Treatment with water resulted in a powder with excellent flow and dispersion properties. However, the treated powder showed varying degrees of significant compositional changes from the original particles. This was confirmed by microscopy and x-ray diffraction as a conversion of the aluminum into Bayerite ( $\text{Al}[\text{OH}]_3$ ).
7. Treatment with wet steam also produced a powder with excellent flow and dispersion properties. The surface of the powder particles was probably converted into a harder layer of an oxide or a hydroxide. X-ray diffraction technique did not reveal the nature of the surface phase. Surface area measurement by nitrogen adsorption showed that a significant transformation of the surface had taken place. Scanning electron microscopy showed no change in surface texture when compared with the original powder.

8. The steam treatment could be controlled easily to produce a treated powder which differed very little from the original powder in the microscopic appearance of shape and size of the individual particles of the untreated powder.

9. The measured force of adhesion showed that the steam and water treated powders were better than the original powder and powders from other treatments.

10. The tensile strength measurements showed that the steam treated powder had the least tensile strength.

11. An apparatus was developed to test the dispersion properties of the powder in vacuum. It could be used to release a powder reproducibly in a bell jar from an elevated point. The powder particles collected at various locations on the bottom of the jar were analyzed for the number and size of single and agglomerated particles.

12. The steam treated powder showed good dispersion qualities in the vacuum release apparatus.

Further work is needed to identify the surface composition of the steam treated powder. In addition, feasibility of large scale treatment should also be investigated.

## REFERENCES

1. Zimon, A.D., Adhesion of Dust and Powder (Russian Translation), Plenum Press, New York, N.Y., 1969.
2. Krupp, H., "Particle Adhesion: Theory and Experiments", Advances Colloid Interface Science, 1:111, 1967.
3. Corn, M., "Adhesion of Particles", chapter in Aerosol Science, Academic Press, New York, N.Y., 1966.
4. Vold, M.J., "The Effect of Adsorption on the van der Waals Interaction of Spherical Colloidal Particles", J. Colloid Science, 16:1, 1961.
5. Böhme, G., Egey, Z, and Krupp, H., Z. Angew. Phys., 19:265, 1965.
6. Böhme, G., Hohn, P., Krupp, H., Rabenhorst, H., Schnabel, W., and Walter, G., "Adhesion of Gold Particles to Silicon and Gold Substrates in Ultrahigh Vacuum", J. Appl. Phys., 44(9):3914, 1973.
7. Donald, D.K., "Contribution of Change to Powder Particle Adhesion", presented at the Symposium on Recent Advances in Adhesion, 162nd National American Chemical Society Meeting, September 1971.
8. Pietsch, I.W., Staub-Reinhalt. Luft (English Translation), 27(1):24, 1967.
9. Rumpf, H., "The Strength of Granules and Agglomerates", published in Agglomeration, Interscience Publishers, Inc., New York, N.Y., pp. 379-418, 1962.
10. Salisbury, J.W., Glaser, P.E., Stein, B.A., and Vonnegut, B., "Adhesive Behavior of Silicate Powders in Ultrahigh Vacuum", J. Geophysical Res., 69(2):235, 1964.
11. "Vacuum Treatment of Prealloyed Aluminum Powders at Moderate Temperatures", AD-769074, prepared by Kaiser Aluminum and Chemical Corp. for Army Materials and Mechanics Research Center, Watertown, Mass., Report No. AMMRC CTR 73-33, October 1973.
12. Svoboda, J., Sourek, V., and Praha, V., "Oxide Layer on the Surface of Objects Coated with Aluminum in Vacuum", prepared by Foreign Technology Division, Project No. 7343, source Czechoslovakia Patent No. 134171, 1969.

REFERENCES (Cont.)

13. Bohemen, J., Lanjer, S.H., Perrett, R.H., and Purnell, J.H., "A Study of the Adsorptive Properties of Firebrick in Relation to Its Use as a Solid Support in Gas-Liquid Chromatography", J. Chem. Soc., 2444, 1960.
14. Sweeley, C.C., Bentley, R., Makita, M., and Wells, W.W., "Gas Liquid Chromatography of Trimethylsilyl Derivatives of Sugars and Related Substances", J. Am. Chem. Soc., 85:2497, 1963.
15. Vandergaer, J.E., "Microencapsulation: Processes and Applications", Plenum Press, New York, N.Y., 1974.
16. Maylotte, D.H. and Wright, A.N., "Surface Photopolymerization of Tetrafluoroethylene", Faraday Diss. Chem. Soc., 58:292, 1974.
17. Nash, J.H., Leiter, G.G., and Johnson, A.P., "Fundamental Studies of the Dispersibility of Powdered Materials", Report No. 2256, prepared by General Mills Electronics Group, Minneapolis, Minn., February 1962.

**MISSION**  
*of*  
**Rome Air Development Center**

*RADC plans and conducts research, exploratory and advanced development programs in command, control, and communications (C<sup>3</sup>) activities, and in the C<sup>3</sup> areas of information sciences and intelligence. The principal technical mission areas are communications, electromagnetic guidance and control, surveillance of ground and aerospace objects, intelligence data collection and handling, information system technology, ionospheric propagation, solid state sciences, microwave physics and electronic reliability, maintainability and compatibility.*



Printed by  
United States Air Force  
Hanscom AFB, Mass. 01731