

UNCLASSIFIED

SECURITY CLASSIFICATION OF THIS PAGE (When Data Entered)

REPORT DOCUMENTATION PAGE		READ INSTRUCTIONS BEFORE COMPLETING FORM
1. REPORT NUMBER TOP 3-2-603	2. GOVT ACCESSION NO.	3. RECIPIENT'S CATALOG NUMBER
4. TITLE (and Subtitle) U. S. ARMY TEST AND EVALUATION COMMAND TEST OPERATIONS PROCEDURE "GUN CONTROL SYSTEMS (VEHICULAR)"		5. TYPE OF REPORT & PERIOD COVERED Final
		6. PERFORMING ORG. REPORT NUMBER
7. AUTHOR(s)	8. CONTRACT OR GRANT NUMBER(s)	
9. PERFORMING ORGANIZATION NAME AND ADDRESS U. S. Army Aberdeen Proving Ground (STEAP-MT-M) Aberdeen Proving Ground, Maryland 21005		10. PROGRAM ELEMENT, PROJECT, TASK AREA & WORK UNIT NUMBERS AMCR 310-6
11. CONTROLLING OFFICE NAME AND ADDRESS U. S. Army Test and Evaluation Command (DRSTE-ME) Aberdeen Proving Ground, Maryland 21005		12. REPORT DATE 13 August 1976
		13. NUMBER OF PAGES 25
14. MONITORING AGENCY NAME & ADDRESS (if different from Controlling Office)		15. SECURITY CLASS. (of this report) Unclassified
		15a. DECLASSIFICATION/DOWNGRADING SCHEDULE
16. DISTRIBUTION STATEMENT (of this Report) Approved for public release; distribution unlimited.		
17. DISTRIBUTION STATEMENT (of the abstract entered in Block 20, if different from Report)		
18. SUPPLEMENTARY NOTES		
19. KEY WORDS (Continue on reverse side if necessary and identify by block number) Gun Control Weapon, Vehicle Mounted Fire Control Vehicle, Tracked		
20. ABSTRACT (Continue on reverse side if necessary and identify by block number) Provides a method of evaluating the performance characteristics of tank gun control systems. Covers azimuth indicator backlash and accuracy, turret friction, gun balance, manual handcrank force, manual response ratio, weapon and sighting system backlash, power controller, static stability, laying and tracking, slope operations, and firing tests. Includes safety checklist. Not applicable to firing on the move.		

AD-A037 012

US ARMY TEST AND EVALUATION COMMAND
TEST OPERATIONS PROCEDURE

DRSTE-RP-702-102

*Test Operations Procedure 3-2-603
AD No. A037012

13 August 1976

GUN CONTROL SYSTEMS (VEHICULAR)

		<u>Page</u>
Paragraph 1.	SCOPE	1
2.	FACILITIES AND INSTRUMENTATION	1
3.	PREPARATION FOR TEST	3
4.	TEST CONTROLS.	4
5.	PERFORMANCE TESTS.	4
5.1	Azimuth Indicator Backlash and Accuracy.	4
5.2	Elevation Quadrant Zeroing and Accuracy.	5
5.3	Turret Friction.	5
5.4	Main Gun Balance	6
5.5	Manual Handcrank Force	6
5.6	Manual Response Ratio.	6
5.7	System Backlash.	7
5.8	Power Controller Neutral Zone Characteristics.	7
5.9	Power Controller Operating Torque.	8
5.10	Override Control	8
5.11	Power Response Rate.	8
5.12	Power Acceleration (for Systems with Override Feature).	9
5.13	Static Stability	10
5.14	Laying Tests	10
5.15	Tracking Tests	11
5.16	Slope Operational Capabilities	12
5.17	Firing Tests	13
6.	DATA REDUCTION AND PRESENTATION.	14
APPENDIX A.	MOVING TARGET SIMULATOR.	A-1
B.	SAFETY CONSIDERATIONS.	B-1

1. SCOPE. This TOP describes the tests for measuring and evaluating the performance characteristics of gun control systems for vehicle mounted weapons. Tests are related to turret operation in a stationary vehicle or in a vehicle that halts to fire. Firing major caliber weapons while moving (with a stabilized gun control system) is discussed in TOP 3-2-602. Secondary armament controls may be tested in accordance with applicable portions of this procedure and TOP/MTP 3-2-075.

2. FACILITIES AND INSTRUMENTATION.

2.1 Facilities.

<u>ITEM</u>	<u>REQUIREMENTS</u>
Firing ranges	Selected from the tank gunnery ranges described in TOP 1-1-011 to suit test

*This TOP supersedes MTP 3-2-603, 13 July 1966.

13 August 1976

<u>ITEM</u>	<u>REQUIREMENTS</u>
	requirements. Equivalent courses may be used.
Moving target vehicle or Moving target simulator	A suitable truck or vehicle for the mounting of targets. Refer to appendix A.
Targets	Panels made of expendable material containing a square target of the size specified for the test.
Gridboard	A panel with grid spacing marked to permit location of aiming points to within ± 0.10 mil for distance employed from the weapon.
Chamber adapters or V-block mount	To facilitate mounting of reference telescope.

2.2 Instrumentation

<u>ITEM</u>	<u>MAXIMUM ERROR OF MEASUREMENT*</u>
Gated TV tracker, IR tracker, or gun-mounted camera (TOP 3-2-602)	Angular distance between line of fire, line of sight, and target to ± 0.1 mil.
Gyro-rate sensor with an oscillograph or magnetic tape recorder	Angular rate up to 800 mils/sec; $\pm 1\%$ of reading.
Protractor	360°; ± 5 min of arc.
Timing device (stopwatch or other suitable device)	± 0.1 sec.
Spring scale	Pulling force in lb; $\pm 2\%$ of full scale reading.
Gunner's quadrant	± 0.4 mil.
Speed measuring device (fifth wheel with speed indicator)	0 to 100 mph; $\pm 2\%$ of full-scale range.
Reference telescope	32-power.

*Values may be assumed to represent ± 2 standard deviations; thus the stated tolerances should not be exceeded in more than 1 measurement out of 20.

3. PREPARATION FOR TEST.

3.1 Safety Evaluation. Before and during testing, establish assurance that the system can be operated and maintained with minimum risk to personnel. Evaluate the safety of the gun control system using the guidance provided in TOP/MTP 3-2-503 and the safety considerations in appendix B. Use the information collected during this evaluation and the vehicle safety evaluation (TOP 2-2-508) to prepare a recommendation for the issuance of a safety release by TECOM (DARCOM-R 385-12 with TECOM Suppl 1*).

3.2 Electrical System.

a. Determine the weapon system power demand during various modes of operation in accordance with TOP 2-2-601. Include the following conditions:

- (1) Standby - system on, controller released.
- (2) Neutral - system on, controller grasped.
- (3) Slew - maximum traverse rate, steady state, maximum elevation.
- (4) Intermediate rates - traverse, steady state, elevation steady state.
- (5) Acceleration - maximum acceleration and deceleration of traverse and elevation combined.

b. Check that the voltage supply to the turret through the slip-rings is sufficient for 360° of traverse.

c. Check that all components, especially safety devices, function at low or minimum voltages.

d. Insure that null and gain potentiometers are properly adjusted and that drift in azimuth or elevation can be nulled using the drift knobs for both stabilized and nonstabilized modes of power operation.

3.3 Hydraulic System.

a. Check the system for leakage as follows:

- (1) Wipe system components clean and check that there is no leakage from the deck clearance valve during or after 5 cycles of elevating the main gun in the interference zone.

*DARCOM-R 385-12 with TECOM Suppl 1, Life Cycle Verification of Materiel Safety.

(2) Exercise the turret to simulate laying the gun on a stationary target for 10 minutes and observe leakage. Leakage in the form of a weep or seep is permissible, and leakage at a rate not exceeding one drop in 2 minutes is permissible at the control power pack at the override linkage control box.

b. Verify that the turret system hydraulic oil is at the proper level and that the system accumulators are charged to the required pressure.

c. Verify the use of proper military specification fluid. If contamination with water is suspected, test a sample of fluid for water content. The fluid should not contain more than 0.1 percent water.

3.4 Instrumentation.

a. Mount a 32-power telescope coincidental with the weapon at the coaxial machine gun port to serve as a reference for sight measurements. Telescope rigidity and repeatability are obtained by welding a machined V-block to the gun mount. The V-block mounting permits the telescope to be removed during operating and firing tests without compromising the reference base.

b. Install gated TV tracker, IR tracker, or film camera for tracking tests as described in TOP 3-2-602.

4. TEST CONTROLS.

a. Use only experienced gunners.

b. Simulate a chambered main gun round throughout nonfiring tests.

5. PERFORMANCE TESTS.

5.1 Azimuth Indicator Backlash and Accuracy.

5.1.1 Method.

a. Lay the weapon by pointing the gun tube at a preselected position on a gridboard using a reference telescope. Record the lay point.

b. Position the zero of the gunner aid (outer movable dial) on the azimuth indicator in line with the 1-mil pointer.

c. Traverse the turret clockwise approximately 50 mils and then counterclockwise to zero without overtravel as read on the azimuth indicator.

d. Record the lay point using the reference telescope. The difference between this lay point and the original lay point is the backlash and should not exceed 0.5 mil or the tolerance allowed by the vehicle specification.

e. Using the reference telescope, lay the weapon on the original lay point and traverse the turret 360° back to this point.

f. Check the azimuth indicator for cumulative error. Error should not exceed 2 mils or the tolerance allowed by the vehicle specification.

5.1.2 Data Required. Record azimuth indicator backlash and cumulative error.

5.2 Elevation Quadrant Zeroing and Accuracy.

5.2.1 Method.

a. Level the gun using a calibrated gunner's quadrant.

b. Turn the micrometer knob on the gun elevation quadrant until the bubble in the level vial is centered.

c. Check the micrometer scale setting. If not at zero, loosen the micrometer knob, turn it to zero, and retighten the knob.

d. Check the elevation scale reading. If not at zero, loosen the scale retaining screws, slide the scale to zero, and retighten the screws.

e. Elevate and depress the weapon through its full range and record the elevation quadrant reading versus the gunner's quadrant indication at 10-mil intervals.

5.2.2 Data Required. Record the elevation quadrant scale reading true values as ascertained by the gunner's quadrant and use these values to establish the mean error of the elevation quadrant over its full range of scale readings.

5.3 Turret Friction.

5.3.1 Method.

a. Level the turret complete with gun, sliprings, and azimuth indicator to within 3 mils.

b. With the traverse pinion removed, rotate the turret using a spring scale to measure the starting and steady-state torque in all four turret quadrants in both clockwise and counterclockwise directions.

5.3.2 Data Required. Record the pulling forces and the length of the moment arm used.

5.4 Main Gun Balance.

5.4.1 Method.

a. With the turret level (within 1 degree), attach all components to the gun that are normally attached during combat (e.g. coaxial machine gun, ballistic shield, telescope, etc.), and all OEM or equivalent weight, and load a dummy round in the gun chamber.

b. Release the weapon from its elevation drive link and attach equivalent weight to compensate for its removal.

c. Pull the weapon from maximum to minimum elevation and back using a spring scale to measure static and dynamic pulling forces.

d. Repeat the test a minimum of 15 times.

5.4.2 Data Required. Record static and dynamic pulling forces.

5.5 Manual Handcrank Force.

5.5.1 Method.

a. Mount a pulley on the elevation and traverse handcrank shafts so that a wire or rope cable coiled in the groove will be at a radius equal to the handcrank radius of force application. Secure one end of the cable to the pulley groove and connect the other end to a spring scale. An alternate method is to use a torque wrench with a handcrank adaptor.

b. Measure the initial force required to move each handcrank and the force required to keep each handcrank in motion. Take the data at 30° intervals through 360° of traverse by reading the azimuth indicator and at 5° intervals from maximum to minimum elevation by use of the gunner's quadrant placed on the breech ring quadrant pads. Measurements should be taken for each direction of weapon lay.

c. Repeat the test with the vehicle canted at 15° and then pitched 15°.

5.5.2 Data Required. Record the initial and steady-state forces measured at each point in elevation and traverse, the pulley radius, and the handcrank radius.

5.6 Manual Response Ratio.

5.6.1 Method. Determine the ratio of gun movement to handcrank movement in traverse and elevation as follows:

a. Turn the handcrank one-half a revolution in the direction of measure to eliminate backlash.

b. Scribe a mark on the handcrank housing and one on the handcrank itself.

c. Record the initial gun position as read from the azimuth indicator or the gunner's quadrant placed on the breech ring quadrant pads.

d. Rotate the handcrank for 10 measured revolutions and record the new gun position. To control slippage in manually operated hydraulic systems, rotate the handcrank at a rate of 10 revolutions per minute.

5.6.2 Data Required. Record the initial and final gun positions in both traverse and elevation.

5.7 System Backlash.

5.7.1 Method.

a. Aim the weapon at a gridboard and record the lay point using one of the following instruments: a chamber scope, coaxial telescope, or vehicle mounted telescope or periscope.

b. With the gun control system on or off, apply a perpendicular force to the muzzle of the weapon in each plane of rotation (azimuth and elevation) and record the lay point displacement. The force applied is specified or determined for each system and is normally a force that will yield a torque of 1000 lb-ft for the larger weapons. Also determine residual backlash by releasing the applied force and measuring the return point.

c. Repeat the test with the force reversed 180° for each plane and record the lay point displacement.

5.7.2 Data Required. Record the force applied, moment arm, and lay point displacement in each plane. The difference between the readings in each plane should not exceed 1 mil or the tolerance allowed by the vehicle specification.

5.8 Power Controller Neutral Zone Characteristics.

5.8.1 Method.

a. Center a protractor segment on the traverse pivot of the gunner's and commander's power controllers.

b. Move each controller in each direction of traverse to the point where resistance is encountered and record the angle of free movement (backlash).

c. Move each controller in each direction of traverse and measure the angle from the first point of resistance to the point where turret movement just begins.

d. Repeat the test for elevation.

5.8.2 Data Required. Record the free movement and dead zone angles of the power controllers for elevation and traverse operation.

5.9 Power Controller Operating Torque.

5.9.1 Method. Attach a spring scale to each power controller and measure the tangential force required to move the controller to one-fourth, one-half, three-fourths, and full deflection in both elevation and traverse.

5.9.2 Data Required. Record the length of the moment arm used and the force for each position.

5.10 Override Control.

5.10.1 Method. Evaluate the performance of the override feature of the commander's controller as follows:

a. Lay the gun on a gridboard using the vehicle sighting system. Activate the commander's override control with the commander and gunner controllers in the neutral position, and measure any movement of the gun or turret from the initial gridboard lay point (there should be no movement).

b. Operate the commander's override control while the gunner is laying the gun on a designated target, and observe whether the gun follows the commander's control to a new target. With the gunner control in the neutral position, release the commander's override control and verify that the gunner regains immediate system control.

5.10.2 Data Required. Record any deviations from the performance specified above.

5.11 Power Response Rate.

5.11.1 Method.

a. Center a protractor at each controller pivot so that "zero" is at the center of the backlash or free movement angle (para 5.8).

b. Mount a rate sensor on the traversing or elevating element, depending on which response plane is to be measured first, and connect the sensor output to an oscillograph or magnetic tape recorder.

c. Deflect the controller to predetermined deflection angles and record the steady-state response rate as determined by the rate sensor output voltage. Record the response rate for a sufficient number

13 August 1976

TOP 3-2-603

of deflection points to establish curves of angular velocity as a function of controller displacement. Data are usually obtained in 1° increments of controller deflection up to 10°, and then every 5° up to maximum controller deflection.

d. Repeat the test three times for each controller in each direction of traverse and elevation.

5.11.2 Data Required.

a. Controller deflection in degrees and an oscillographic or tape record of the response rate in mils per second for each deflection position.

b. Any erratic performance of the system.

5.12 Power Acceleration (for Systems with Override Feature).

5.12.1 Method.

a. Mount a gyro-type rate sensor on the traversing element and connect the sensor output to a magnetic tape recorder and/or oscillograph.

b. Measure the initial and steady-state response of the turret to instantaneous deflection inputs. The different operating characteristics of gun control systems preclude the formulation of a definitive procedure for applying deflection inputs to all systems; the following procedures have been employed, however, and may be used as guidance.

Procedure I.

(1) With the system in the stabilized mode, the commander's power controller centered in the neutral zone (para 5.8), and the override control actuated, deflect the gunner's power controller a known amount.

(2) Release the commander's override control and record the system response on the magnetic tape recorder or oscillograph.

Procedure II.

(1) With the system in the nonstabilized mode and the hydraulic pressure system fully charged, turn the turret power switch off, position the controller to the desired deflection, and actuate the palm switch.

(2) Turn the turret power on and record system response on the magnetic tape recorder or oscillograph.

c. Repeat the procedure for different amounts of deflection to cover range of requirement.

5.12.2 Data Required. An oscillographic or tape record of the traversing rate and time to complete system response for each controller deflection.

5.13 Static Stability.

5.13.1 Power-On Test.

5.13.1.1 Method.

a. Place the vehicle on a 15° slope.

b. With the manual controllers stationary and the power controllers in neutral, turn on the control system power for a 10-minute period and observe the system for angular displacement, drift, or hunting oscillations.

5.13.1.2 Data Required. Record the sight reticle angular displacement; angular drift rate; and the frequency, magnitude, and duration of any hunting oscillations that occurred during the 10-minute period.

5.13.2 Power-Off Test.

5.13.2.1 Method.

a. Park the vehicle on a level hardstand.

b. Place a dummy round in the breech.

c. Using the manual controllers, sight the gun on a known fixed target.

d. With the power off, let the system stand for at least 12 hours (overnight).

e. Measure displacement of the sight from the target.

5.13.2.2 Data Required. Record the displacement of the sight from the target and the ambient temperature at the start and end of the test.

5.14 Laying Tests.

5.14.1 Method.

a. Set up a target 25 by 25 cm square at a range of 1000 meters.

b. Boresight the gunner's and commander's sights and the reference telescope to coincide at target range.

NOTE: If the sighting system has a computer controlled boresight feature (where the reticle is electrically driven to boresight position corresponding to a selected range), conduct the test with the boresight feature energized (boresight mode) to prevent superelevation from being introduced.

c. Station an observer at the reference telescope and a gunner at the sight being tested.

d. The gunner deflects the line of sight from the target by a designated amount using the azimuth indicator and elevation quadrant.

e. The observer commands, "Ready-----go!" and simultaneously starts a timer (such as a stopwatch).

f. The gunner, on hearing the command, slews the sight to the target and, when the sighting reticle has come to rest, closes the firing switch.

g. The observer stops the timer when he hears the trigger actuated, and verifies by his sight check that the line of sight is on the target. (The gunner's sight must fall within the square of the target in both azimuth and elevation for every laying condition.)

h. The observer records the time required for the test.

i. Repeat the test a minimum of seven times in alternate directions of lay for each of the conditions in table 1 using three different gunners.

Table 1 - Gun Laying Tests

Position	Layoff, mils*		Typical Time to Relay (sec)	
	Azimuth	Elevation	With Gunner's and Commander's Power Controls	With Manual Controls
1	0	10	2	2
2	25	0	3	3
3	25	10	5	5
4	100	0	4	4.5
5	400	0	5	13.5
6	800	0	6	-
7	1600	0	8	-
8	3200	0	13	-

*Or as specified in requirements document.

5.14.2 Data Required. Record the amount of layoff and the time to lay the gun on target for each test condition.

5.15 Tracking Tests.

5.15.1 Method.

a. Instrument the weapon with a TV camera, IR tracker, or film camera to record the tracking performance of the gun control system. Time and trigger firing pulses can be recorded directly on film when using the camera or on the respective instrumentation recorders when using the IR tracker or TV camera and tracker. Additional information on this instrumentation is contained in TOP 3-2-602.

b. Mount a vertical target, with adequate contrast relative to background and of the size shown in table 2, on a suitable truck, or set up a moving target simulator as shown in figure 6, appendix A. If the truck is used, use a fifth wheel with a speed indicator to maintain the speeds listed in table 2.

Table 2 - Gun Tracking on Moving Target Tests

Expected Time on Target (%)	Traverse Rate mils/sec (Reference)	Established Lead, mils	Target Size		Target Range, meters	Target Velocity		Length of Course, meters
			mils	meters		mph	km/h	
90	0.5	1.0	0.25	0.50	2000	2.0	3.2	50
100	1.0	2.0	1.25	2.50	2000	4.0	6.4	100
100	3.3	7.5	1.25	2.50	2000	13.5	21.7	200
100	9.8	20.0	1.25	2.50	2000	40.0	64.4	200
100	19.6	7.5	1.25	0.34	275	12.0	19.3	400
100	32.6	10.0	1.25	0.34	275	20.0	32.2	400
100	65.2	20.0	5.0	1.38	275	40.0	64.4	400

c. Boresight the TV camera, IR tracker, or film camera with the gunner's and commander's sights at target range.

NOTE: If the sighting system has a computer controlled boresight feature (where the reticle is electrically driven to boresight position corresponding to a selected range), conduct the test with the boresight feature energized (boresight mode) to prevent superelevation from being introduced.

d. Drive the truck back and forth on a curved line course (radius equal to target range) so that the target will be crossing perpendicular to the line of sight (LOS) or use the target simulator to project a moving target image on a screen in front of the vehicle.

e. The gunner positions the LOS to the established lead (table 2) behind the target at which time the LOS may be stationary or moving at a speed equal to or less than the target speed.

f. Upon command, the gunner slews the sight from the established lead behind the target to the target and attempts to keep the LOS on the target, closing the firing switch each time he believes a hit can be made. Each test run ends after 30 seconds or when the course ends, whichever occurs first.

g. Repeat the test for each condition in table 2 (or as specified in requirements document) using a minimum of three gunners with each making at least three runs for each condition and target direction.

5.15.2 Data Required. Record the following for each test condition.

- a. Target size, range, and velocity.
- b. Established lead angle.
- c. Time to lay on target.
- d. Time on target.
- e. Test time.
- f. LOS deviations from target center.

5.16 Slope Operational Capabilities.

5.16.1 Method. Repeat the laying and tracking tests of paragraphs 5.14 and 5.15 with the vehicle pitched or canted on slopes up to and including 15°. At 15° cant, system laying performance should not exceed two times the values given in table 1. Tracking performance should be within 85 percent of performance on level ground, table 2.

5.16.2 Data Required. Record the data as in paragraphs 5.14 and 5.15 for the degrees of cant used.

5.17 Firing Tests. Firing tests determine the effect of firing shock on the gun control system and the capability of the system to produce rapid effective fire.

5.17.1 Method. Refer to TOP/MTP 3-2-605 for guidance on preparation and general conduct of the tests, and computation and analysis of firing data. Five series of tests are applicable.

a. Precision Lay. From a combined layoff of 25 mils horizontally and 10 mils vertically for each round, fire a five-round group with gunner's power controls. Precision engagement in minimum time of a point target on a vertical panel is desired. Control of the test and interpretation of results are based on paragraph 5.14. The time specified is 5.0 seconds per round. The accuracy criteria are a group dispersion comparable to that for slow, deliberate, precision fire, and a center of impact within 1/3-mil of the point of aim (based on proper zeroing).

b. Rapid Lay. Repeat the above procedure stressing minimum time of engagement, firing as soon as the line of sight can be brought approximately to the center of a 7.5-foot-square target.

c. Utility of Operation. Perform a typical combat problem within 15.0 seconds under conditions described in TOP/MTP 3-2-605.

d. Stability. Fire five rounds with manual control without re-laying the weapon between rounds. Repeat using power control. By sight reticle movement, measure the horizontal and vertical components of gun (line of sight) permanent angular displacement per round. The criterion of performance is that the permanent deviation of the line of sight shall not exceed 1 mil horizontally or vertically. Exact return is desired to obviate the need for re-laying.

e. Moving Target. Conduct engagement time and tracking ability tests under standard conditions selected from paragraph 5.15 for a minimum of 10 rounds.

5.17.2 Data Required. Record data as required in TOP/MTP 3-2-605 and paragraphs 5.14 and 5.15.

6. DATA REDUCTION AND PRESENTATION. Tabulate all data collected for each subtest. Reduce the data as indicated for the following subtests.

6.1 Turret Friction. Compute the starting and steady-state torque values from the recorded data.

6.2 Main Gun Balance. Compute the mean torque required for gun balance, in pound-feet (or newton-meters).

6.3 Manual Response Ratio. Determine manual response ratio in "mils per handcrank revolution" for gun elevation and depression and for turret traverse clockwise and counterclockwise.

6.4 Power Controller Neutral Zone Characteristics. Determine the dead-spot for each controller. Deadspot is the handle movement from the neutral center position in either direction required to initiate turret movement. The neutral center position is defined as that handle position which divides the initial free handle movement in half.

6.5 Power Controller Operating Torque. Compute the torque value for each test position from the recorded data.

6.6 Power Response Rate. Plot the recorded data to establish curves of angular velocity versus controller displacement as shown in figure 1.

6.7 Power Acceleration. Scale the oscillographic trace and develop curves as shown in figures 2, 3, and 4. Read rise time, overshoot, undershoot, and damping time from the curves as indicated.

6.8 Laying and Tracking. Calculate the average gun laying times and the percent of time on target for each test condition. Plot average laying times as shown in figure 5.

6.9 Firing Tests. Reduce the firing data in accordance with TOP/MTP 3-2-605.

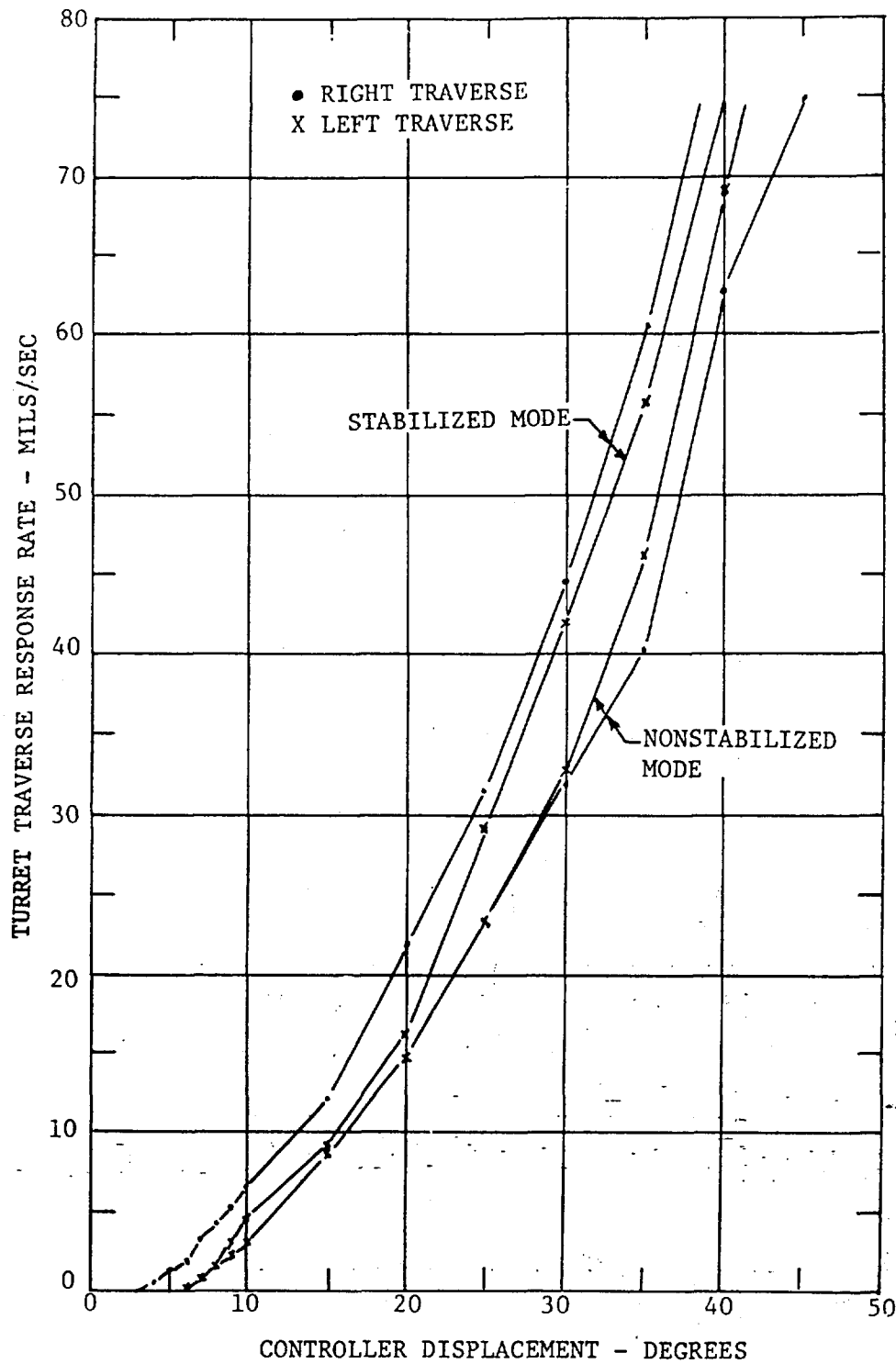

Figure 1. Turret Traverse Response Rate Characteristics, Commander's Control.

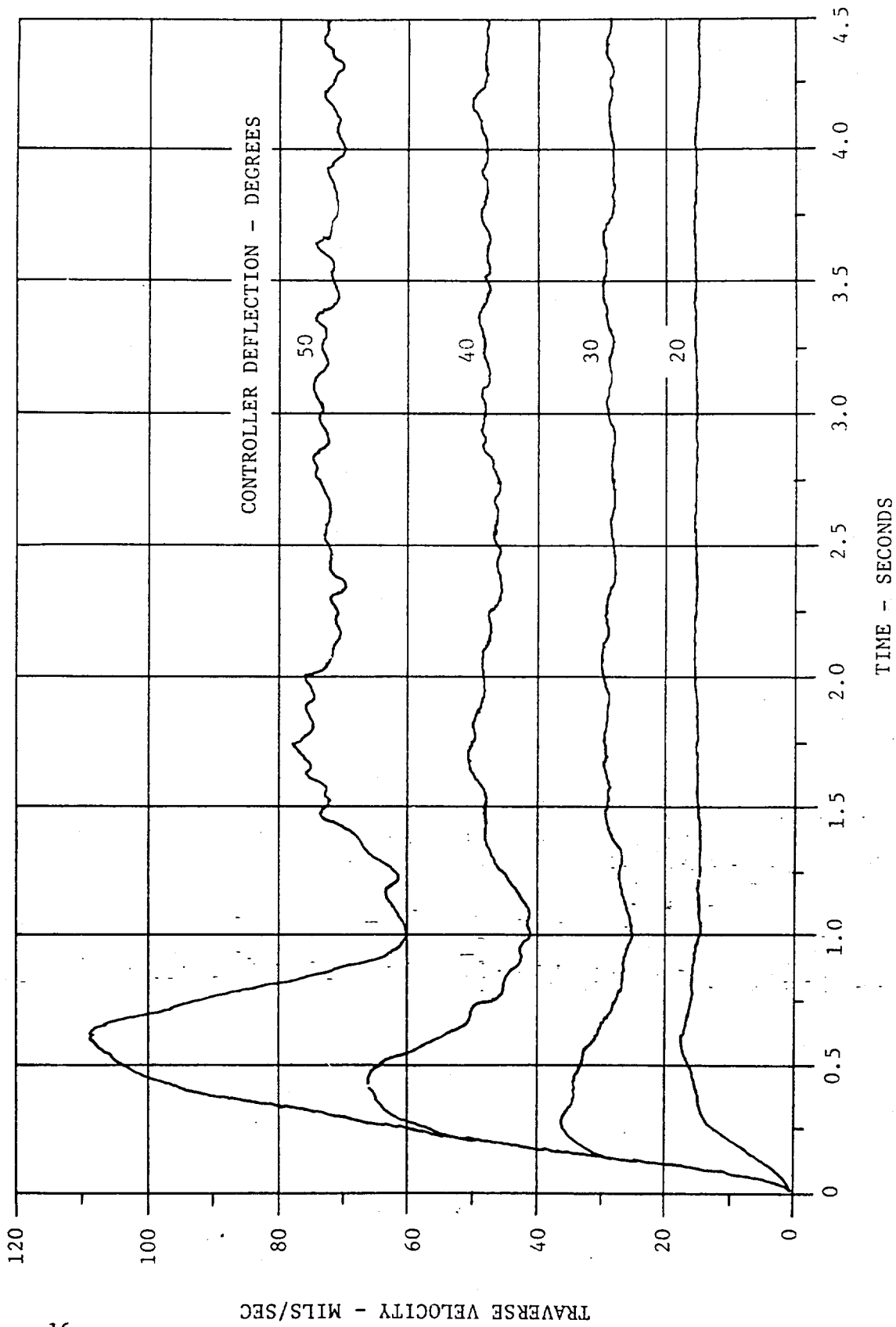

Figure 2. Turret Power Acceleration Characteristics, Stabilized Mode, Right Traverse.

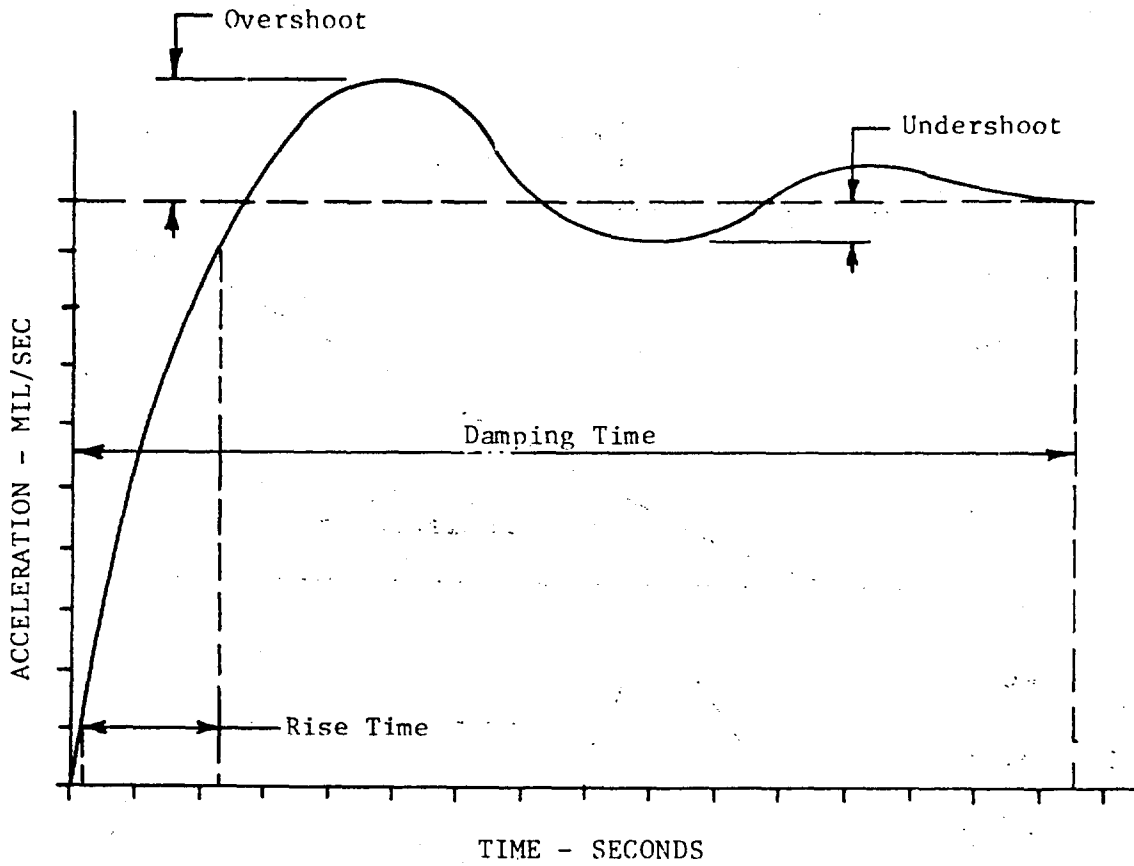

Figure 3. Acceleration Characteristics.

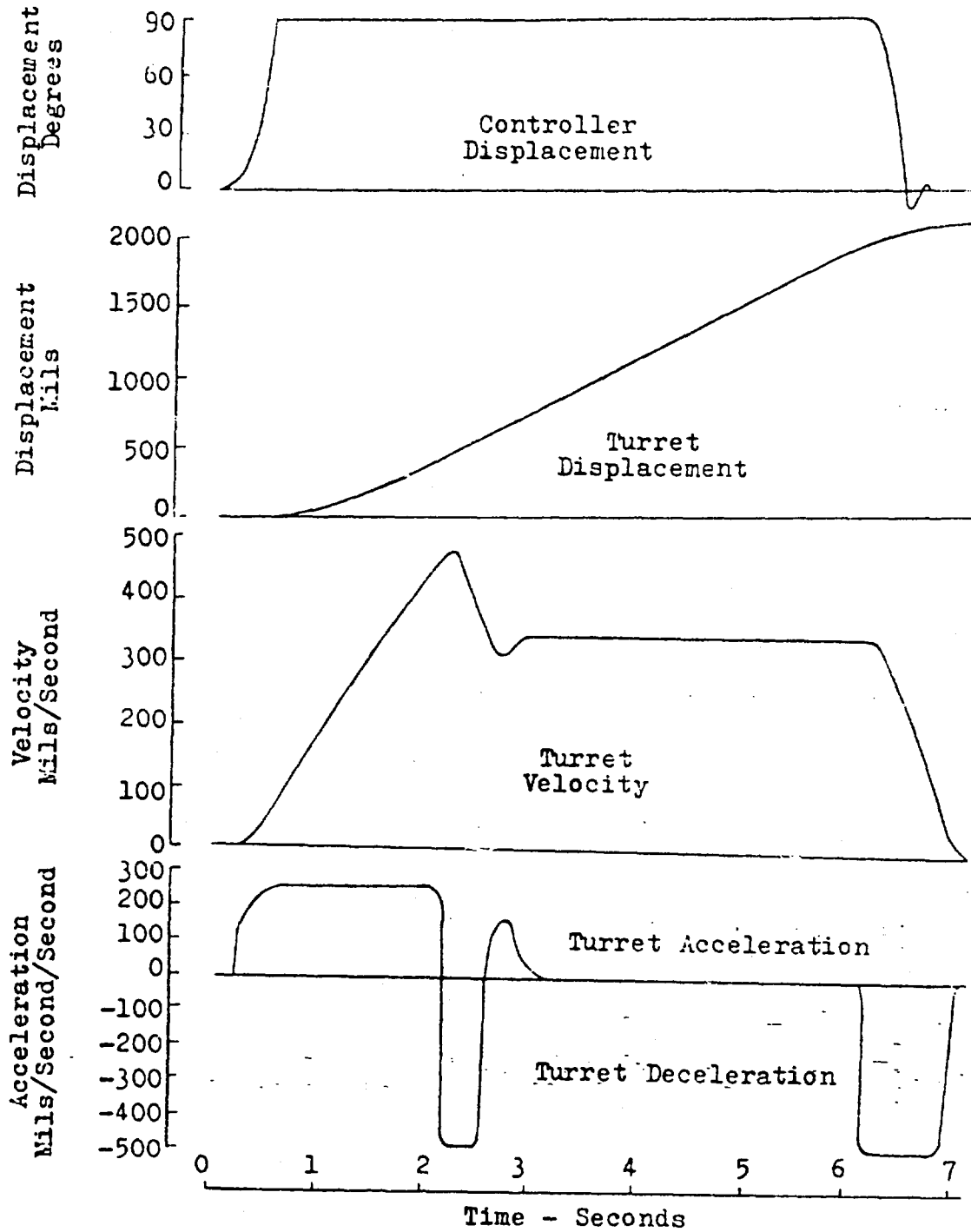

Figure 4. Turret Clockwise Angular Motion Versus Time.

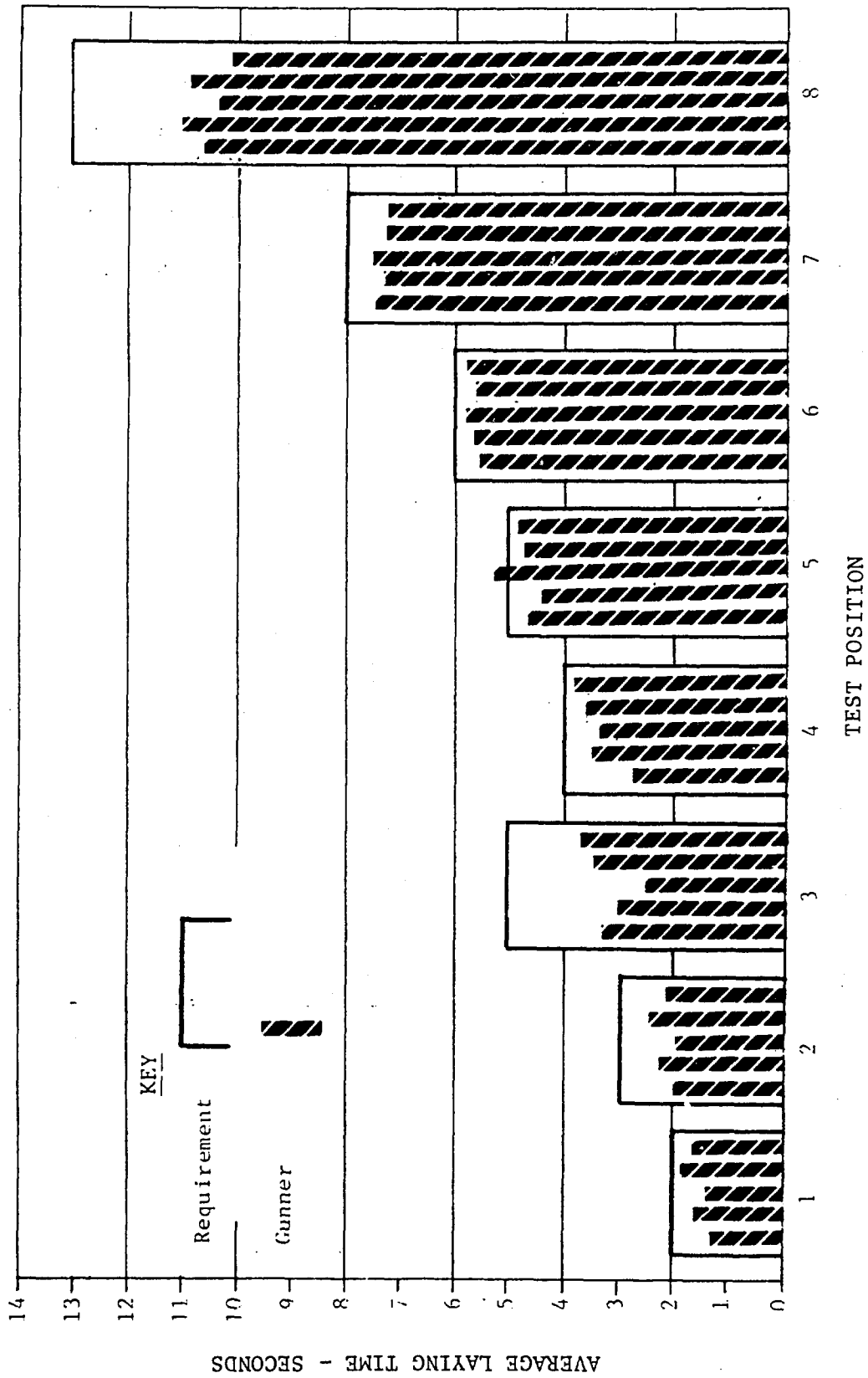

Figure 5. Gunner's Average Laying Times for Test Positions; Power Mode at Gunner's Station.

13 August 1976

Recommended changes to this publication should be forwarded to Commander, U. S. Army Test and Evaluation Command, ATTN: DRSTE-ME, Aberdeen Proving Ground, Md. 21005. Technical information may be obtained from the preparing activity: Commander, U. S. Army Aberdeen Proving Ground, ATTN: STEAP-MT-M, Aberdeen Proving Ground, Md. 21005. Additional copies are available from the Defense Documentation Center, Cameron Station, Alexandria, Va. 22314. This document is identified by the accession number (AD No.) printed on the first page.

APPENDIX A
MOVING TARGET SIMULATOR

The motion of the maneuvering target is emulated by a moving image projected on a screen in front of the tank. It is not necessary to project an image of a target vehicle as such, but only a spot which appears to the gunner to move along a normal target vehicle path. This spot is projected by a small continuous-wave laser with a scanning mirror used to control motion of the spot. The projection screen is curved to minimize parallax errors. A digital computer is used to control the scanning mirror and thereby move the spot in all desired target paths and speeds. The digital computer also has the capability of sending fire commands to the gunner at preselected times or target positions.

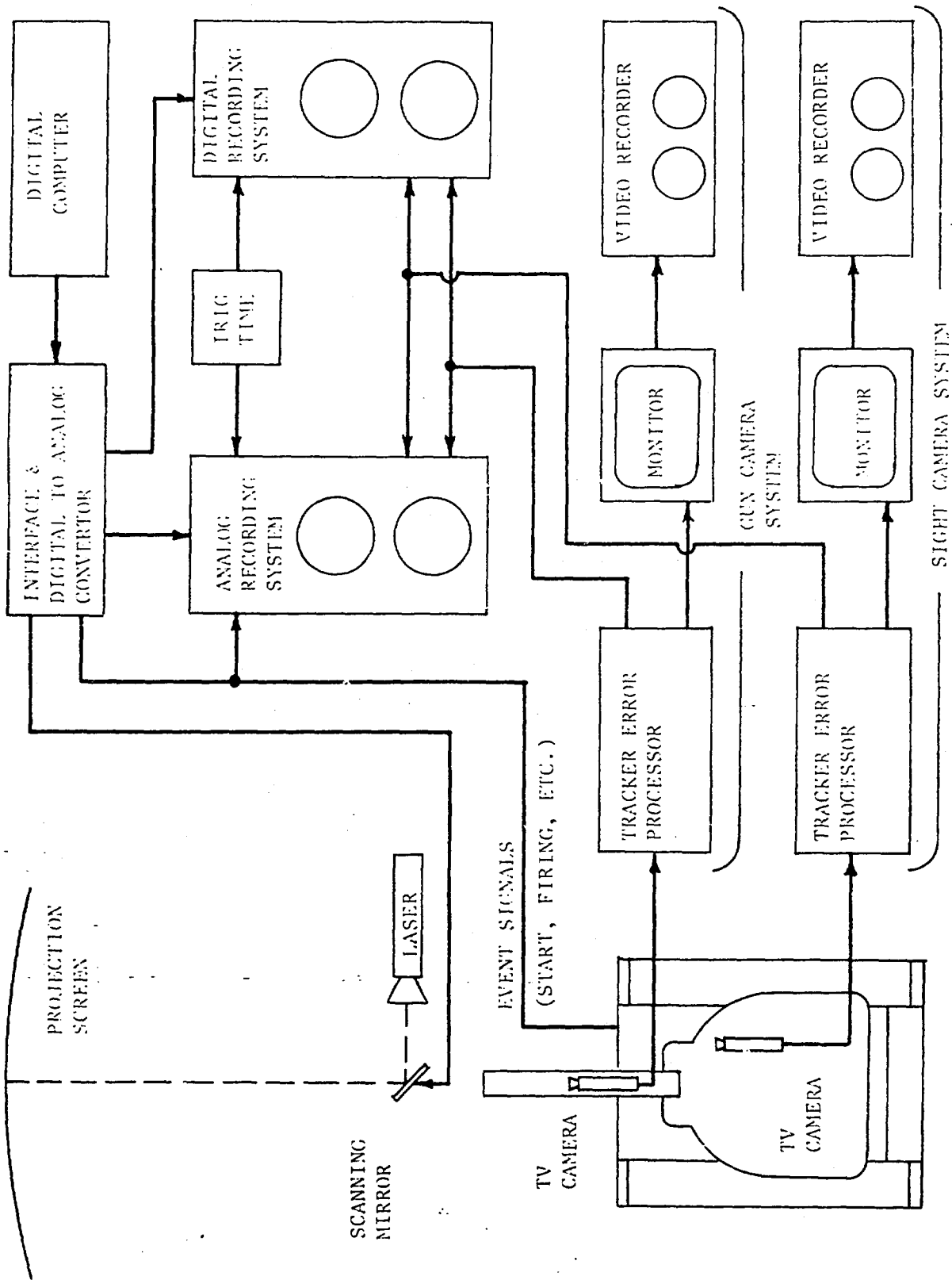

Figure 6. Moving Target Simulator.

APPENDIX B
SAFETY CONSIDERATIONS

Evaluate the following safety considerations as being satisfactory (S), unsatisfactory (U), or not applicable (NA).

<u>ITEM</u>	S	U	NA	Comments
1. Safety of personnel is not jeopardized by sharp, pointed, or hazardous projections.				
2. All components and items of on-equipment materiel (OEM) provide proper utility for the crew without causing a hazard.				
3. Adequate safety devices such as limit switches, stops, etc., are provided to protect personnel and equipment during weapon operation. Some typical limit switches are: <u>Back Deck Limit Switch</u> - elevates the weapon to prevent it from striking the vehicle when traversing over the back deck. <u>Driver's Hatch Limit Switch</u> - activates when the hatch is open to prevent it from striking the vehicle when traversing over the back deck. <u>Loader's Limit Switch</u> - prevents turret motion while crew members reach through the turret basket to remove ammunition from hull-mounted racks.				
4. The electrical system does not present a high voltage or current hazard. All components and wires that retain dangerous voltages when equipment is off are located where personnel are not likely to touch them by accident and are labeled or otherwise identified for crew personnel.				
5. Weapon system does not become erratic or uncontrollable during warmup cycle.				
6. The relief valve in the accumulator circuit prevents excessive pressures from endangering the crew.				

