

AD-A037 125

NATIONAL AVIATION FACILITIES EXPERIMENTAL CENTER ATL--ETC F/6 17/9  
EVALUATION OF A CORRELATION-SENSITIVE AUTOMATIC CLUTTER ELIMINA--ETC(U)  
MAR 77 W C SWANSEN

UNCLASSIFIED

FAA-NA-76-40

FAA-RD-76-220

NL

[OF]  
AD  
A037125



END  
DATE  
FILMED  
4-77

Report No. **FAA-RD-76-220**

AD A037125

**EVALUATION OF A CORRELATION-SENSITIVE AUTOMATIC CLUTTER ELIMINATOR.**

**William C. Swanseen**

**FAA-NA-76-40**



**March 1977**

**FINAL REPORT, Nov 75-Apr 76,**

Document is available to the public through the  
National Technical Information Service  
Springfield, Virginia 22151

**U. S. DEPARTMENT OF TRANSPORTATION  
FEDERAL AVIATION ADMINISTRATION**

Systems Research & Development Service

Washington, D.C. 20590

240 550

#### NOTICE

This document is disseminated under the sponsorship of the Department of Transportation in the interest of information exchange. The United States Government assumes no liability for its contents or use thereof.

## METRIC CONVERSION FACTORS

Approximate Conversions to Metric Measures			Approximate Conversions from Metric Measures					
Symbol	When You Know	Multiply by	To Find	Symbol	When You Know	Multiply by	To Find	Symbol
<b>LENGTH</b>								
in	inches	2.5	centimeters	cm	millimeters	0.04	inches	in
ft	feet	30	meters	m	centimeters	0.4	inches	in
yd	yards	0.9	kilometers	km	meters	3.3	feet	ft
mi	miles	1.6			kilometers	1.1	yards	yd
						0.6	miles	mi
<b>AREA</b>								
in <sup>2</sup>	square inches	6.5	square centimeters	cm <sup>2</sup>	square centimeters	0.16	square inches	in <sup>2</sup>
ft <sup>2</sup>	square feet	0.09	square meters	m <sup>2</sup>	square meters	1.2	square yards	yd <sup>2</sup>
yd <sup>2</sup>	square yards	0.8	square kilometers	km <sup>2</sup>	square kilometers	0.4	square miles	mi <sup>2</sup>
mi <sup>2</sup>	square miles	2.6	hectares	ha	hectares (10,000 m <sup>2</sup> )	2.5	acres	
	acres	0.4						
<b>MASS (weight)</b>								
oz	ounces	28	grams	g	grams	0.035	ounces	oz
lb	pounds	0.45	kilograms	kg	kilograms	2.2	pounds	lb
	short tons (2000 lb)	0.9	tonnes	t	tonnes (1000 kg)	1.1	short tons	
<b>VOLUME</b>								
tsp	teaspoons	5	milliliters	ml	milliliters	0.03	fluid ounces	fl oz
Tbsp	tablespoons	15	milliliters	ml	liters	2.1	pints	pt
fl oz	fluid ounces	30	milliliters	ml	liters	1.06	quarts	qt
c	cups	0.24	liters	l	liters	0.26	gallons	gal
pt	pints	0.47	liters	l	cubic meters	35	cubic feet	ft <sup>3</sup>
qt	quarts	0.95	liters	l	cubic meters	1.3	cubic yards	yd <sup>3</sup>
gal	gallons	3.8	liters	l				
ft <sup>3</sup>	cubic feet	0.03	cubic meters	m <sup>3</sup>				
yd <sup>3</sup>	cubic yards	0.76	cubic meters	m <sup>3</sup>				
<b>TEMPERATURE (exact)</b>								
°F	Fahrenheit temperature	5/9 (after subtracting 32)	Celsius temperature	°C	Celsius temperature	9/5 (then add 32)	Fahrenheit temperature	°F

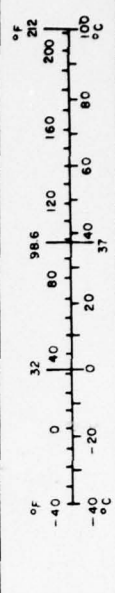

<sup>1</sup> 1 in. = 2.54 in. exactly. For other exact conversions and more detailed tables, see NBS Monograph 16, Units of Weights and Measures, Price \$2.25, SD Catalog No. C7110-286.

Technical Report Documentation Page

1. Report No. FAA-RD-76-220		2. Government Accession No.		3. Recipient's Catalog No.	
4. Title and Subtitle EVALUATION OF A CORRELATION-SENSITIVE AUTOMATIC CLUTTER ELIMINATOR				5. Report Date March 1977	
				6. Performing Organization Code	
7. Author(s) William C. Swanseen				8. Performing Organization Report No. FAA-NA-76-40	
9. Performing Organization Name and Address Federal Aviation Administration National Aviation Facilities Experimental Center Atlantic City, New Jersey 08405				10. Work Unit No. (TRAIS)	
				11. Contract or Grant No. 122-111-320	
12. Sponsoring Agency Name and Address U.S. Department of Transportation Federal Aviation Administration Systems Research and Development Service Washington, D.C. 20590				13. Type of Report and Period Covered Final November 1975-April 1976	
				14. Sponsoring Agency Code	
15. Supplementary Notes					
16. Abstract A prior computer simulation conducted by MITRE Corporation indicated that an automatic clutter eliminator (ACE) using correlation information within the clutter sum register of the common digitizer (CD) could be used to improve target detection and reduce false targets due to radar weather clutter. Project personnel at the National Aviation Facilities Experimental Center (NAFEC) designed and fabricated a real time hardware device to perform the correlation estimation and lead edge generation according to the MITRE requirement. A series of tests was conducted to compile data comparing digitizer performance using the correlation-sensitive ACE/CD with performance from an unmodified CD. Test results indicate reductions in false targets up to 30 percent are possible with no loss of real target detection. It was concluded that further field testing of correlated ACE techniques be accomplished to confirm performance under many various radar and weather situations.					
17. Key Words Radar Weather Clutter Digital Processing			18. Distribution Statement Document is available to the public through the National Technical Information Service, Springfield, Virginia 22151		
19. Security Classif. (of this report) Unclassified		20. Security Classif. (of this page) Unclassified		21. No. of Pages 21	22. Price

*ii*

PREFACE

Acknowledgment is made to the following personnel for their assistance in the design, fabrication, and evaluation of the correlation estimator hardware:

1. Mr. Andrew Gemski, who was responsible for the design of the correlation estimator hardware,
2. Mr. Edward Mancus, who completed the interface of the correlation estimator to a paper tape reader and assisted in data collection, and
3. Messrs. Michael Hulse, Sherman Holland, and Roy Gilmartin for their assistance in the fabrication and site testing of this modification.

ACCESSION for	
NTIS	White Section <input checked="" type="checkbox"/>
DDC	Ball Section <input type="checkbox"/>
UNANNOUNCED	<input type="checkbox"/>
JUSTIFICATION.....	
BY.....	
DISTRIBUTION/AVAILABILITY CODES	
Dist.	AVAIL. and/or SPECIAL
A	

## TABLE OF CONTENTS

	Page
INTRODUCTION	1
Purpose	1
Background	1
Method of Approach	1
SYSTEM DESCRIPTION	2
General	2
Detailed Description	5
TEST PROCEDURES AND RESULTS	6
Detection Improvement Criteria	6
Hardware Verification	6
8x12 Window Evaluation	7
Curve Optimization	7
24x12 ACE Window Tests	10
SUMMARY OF RESULTS	13
CONCLUSIONS	14
RECOMMENDATION	14
REFERENCES	14

## LIST OF ILLUSTRATIONS

Figure		Page
1	N1, N11 Chassis, Block Diagram	3
2	T <sub>L</sub> Chassis, Block Diagram	4
3	Equipment Configuration for Recording Quantized Hits from the CD	10

## LIST OF TABLES

Table		Page
1	Probability of Detection Results Using 8x12 Windows	8
2	Reduction in Search Data Count Using Various Window Sizes	9
3	Frequency of Occurrence of Pairs in the Clutter Sum Window (24x12)	9
4	Tape 76-06 P <sub>d</sub> Results	11
5	Tape 74-07 P <sub>d</sub> Results	11
6	Tape 74-13 P <sub>d</sub> Results	11
7	Search Data Count Results	12

## INTRODUCTION

### PURPOSE.

The purpose of this activity was to design, fabricate, and test a correlation-sensitive automatic clutter eliminator (ACE). This new ACE was interfaced with the existing common digitizer (CD) at Elwood, New Jersey, and data were compiled comparing the digitizer performance using the correlation-sensitive ACE with performance from an unmodified CD.

### BACKGROUND.

The basis for the development of the correlation-sensitive ACE hardware was prepared by MITRE Corporation. Two reports were published commenting on simulation results obtained using a second-threshold detector lead edge which was dependent on both the number of hits in the second-threshold window and the number of azimuth pairs of hits in the window.

The first of these reports (reference 1) was based on completely synthetic representations of radar data. The probability of noise ( $P_n$ ) distribution and the correlation coefficients used in this simulation were artificial and assumed to be constant. Target detection validation was also derived from artificial sources. The results of this study indicated a possible reduction in the probability of false alarms ( $P_{fa}$ ) by as much as 75:1. This was reported along with a possible improvement in true target detection.

The second MITRE report (reference 2) was a direct result of the first report. The second report attempted to obtain simulation results based on input data which were more representative of true second-level threshold detector inputs.

To obtain representative data, digital records were made of the input hits to the sliding window in the CD at Elwood. Recordings were made for different clutter areas and two types of first-level quantizers. The result of this simulation indicated a substantial (not nearly 75:1) reduction in  $P_{fa}$  using a correlation-sensitive ACE. Target detection results were again based on simulated target inputs.

It was noted in the second MITRE document that "Simultaneous gains in detection and reductions in the false alarm rate are possible, because the correlation-sensitive ACE uses leading edge thresholds both above and below those used by the present ACE." It was these optimistic simulation results which prompted the development of the correlated ACE hardware at the National Aviation Facilities Experimental Center (NAFEC).

### METHOD OF APPROACH.

The method used to test the ACE modification was to replay recorded radar video data into the modified and unmodified CD. The CD outputs were then

recorded for offline data analysis and reduction. The conclusions and recommendations contained in this report are based on a comparison of the performance data obtained in this manner.

## SYSTEM DESCRIPTION

### GENERAL.

The design goals established for the NAFEC-correlated ACE modifications were the following:

1. Provide a flexible, programmable method of determining the lead edge criteria based on the number of hits and the number of pairs of hits in a variable window,
2. Minimize the number of interface connections between the CD and ACE modification, and
3. Allow for quick conversion from the unmodified to the modified CD.

These design objectives were obtained using the system shown as a block diagram in figures 1 and 2. The signals sent from the CD to the ACE modification are;

1. Radar triggers,
2. Gated 1/4-nautical mile (nmi) clocks, and
3. Standardized, clocked, quantized hits from the sliding window input.

The correlation estimator hardware contains enough memory to store 19 sweeps of data. A single bit is stored for each 1/4-nmi range cell from minimum processing range to maximum range for each of the 19 sweeps. Switch selection on the ACE unit allows for selection of a window size from 0 to 19 sweeps by 3 to 31 range cells. Within the selected ACE window the number of hits and the number of azimuth pairs of hits is counted. These two counts ("hits" and "pairs") are used in a two-dimensional look-up table to determine what value of lead edge will be used. This summation and look-up process is repeated each range cell as new data are shifted into and out of the ACE window.

The output of the correlation estimator is five bits of lead edge information. These five bits replace the five bits of manual lead edge threshold ( $T_L$ ) selected by switches on the CD. The ACE selector switch on the CD is then turned OFF, forcing the lead edge to be determined by the ACE modification.

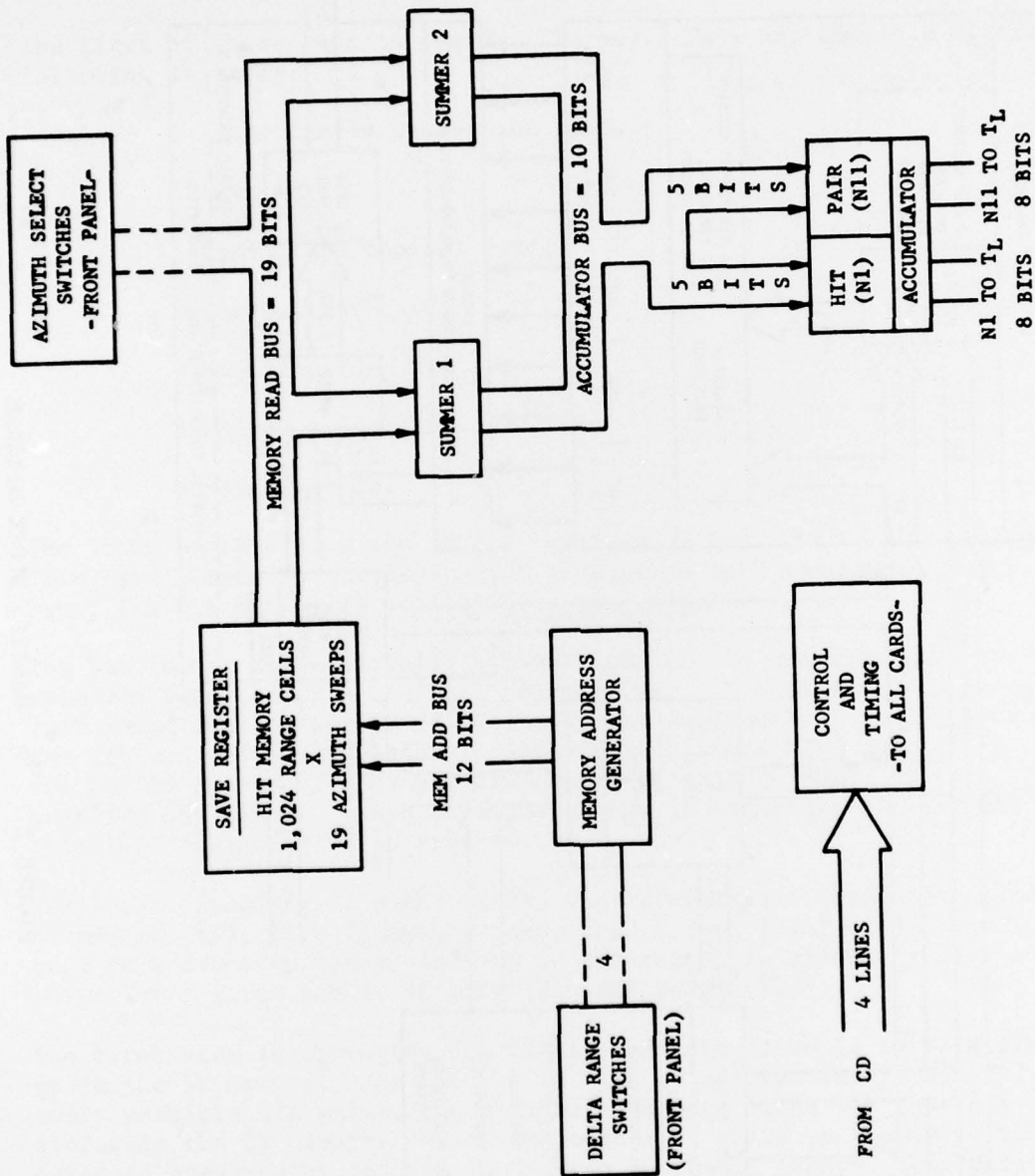

76-40-1

FIGURE 1. N1, N11 CHASSIS, BLOCK DIAGRAM

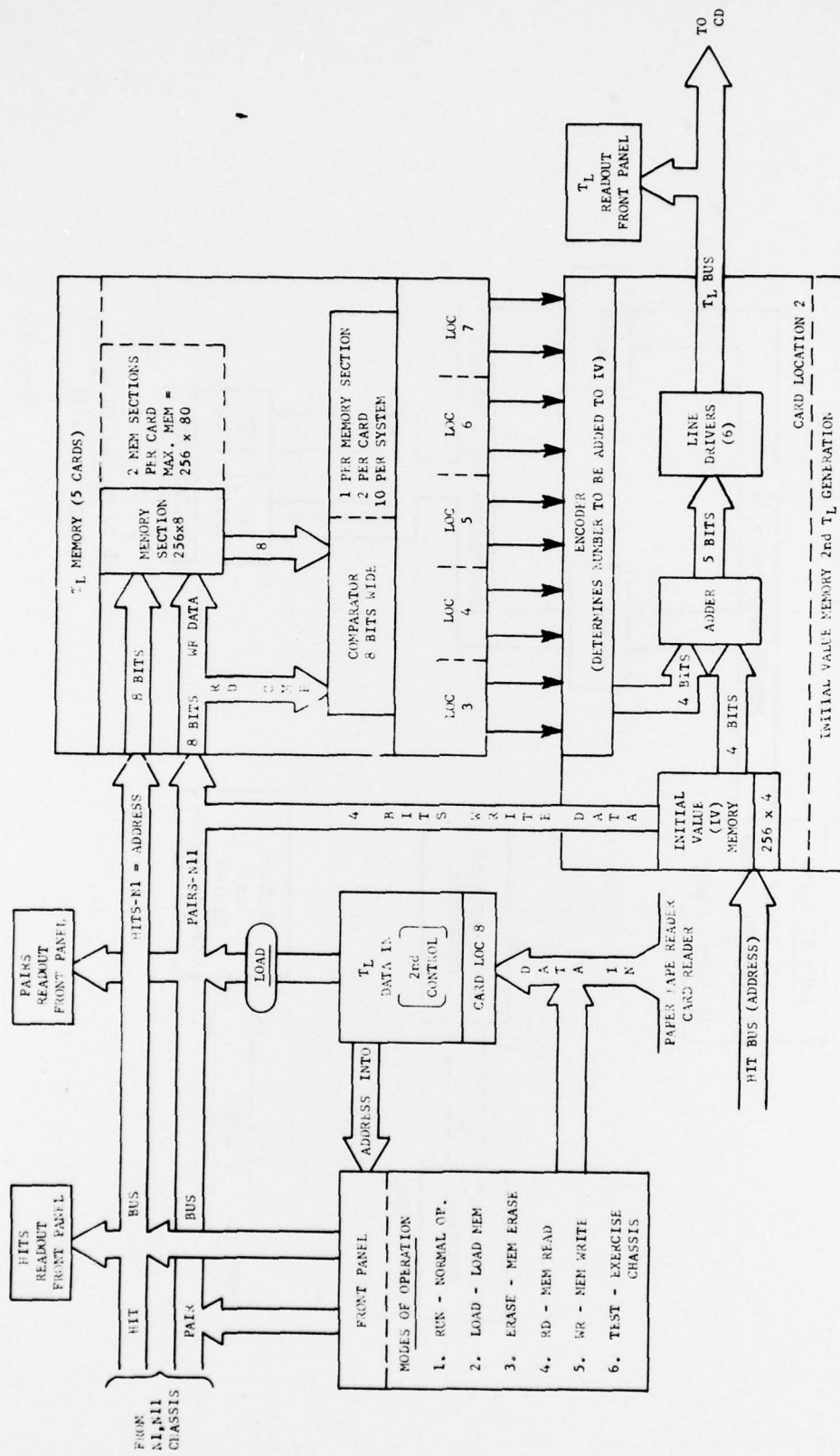

76-40-2

FIGURE 2. TL CHASSIS, BLOCK DIAGRAM

#### DETAILED DESCRIPTION.

The correlation estimation ACE modification is divided into two bays of cards, each performing an independent function in the generation of the final  $T_L$  values.

The first of these bays is the N1, N11 bay. This bay consists of the following 12 cards:

- 1 interchassis connection card,
- 1 test card,
- 1 timing and control card,
- 1 accumulator card,
- 2 summer cards,
- 1 address generator card, and
- 5 memory cards.

The input signals from the CD are received on the control and timing card. This card generates the basic control signals used throughout the N1, N11 bay. The hit memory is contained in this bay.

The hit memory is essentially a binary map of the quantizer output data received from the CD. The full range of data is stored for 19 sweeps. During each range cell, a series of additions and subtractions is performed on both the hit and pair accumulators. These accumulators thus maintain a running sum of the number of hits and the number of azimuth pairs of hits in the selected ACE window. Each accumulator has an eight-bit output, and it is this information which is sent to the  $T_L$  bay.

The  $T_L$  bay consists of eight cards, one interchassis connection card, one IV memory card, five  $T_L$  memory cards, and a data input card. The  $T_L$  bay acts as a two-step memory look-up to determine the necessary lead edge value for a given number of hits (N1) and pairs (N11).

The first step in computing the final lead edge value is to do a direct look-up in the IV memory. The hit bus is used to address the IV memory. For every possible hit value, the minimum lead edge value for that hit count is stored in the IV memory. Next, the number of pairs on the pairs bus is compared to break-point information stored in the  $T_L$  memory. The output of the  $T_L$  memory is then added to the output of the IV memory to determine the final lead edge value sent to the CD. A paper tape reader is interfaced with the data-in card to provide high-speed loading of the IV memory and the  $T_L$  break-point memory.

## TEST PROCEDURES AND RESULTS

### DETECTION IMPROVEMENT CRITERIA.

The criteria established for evaluation of the ACE improvements were as follows:

1. A reduction in false alarms by 30 percent,
2. No reduction in clear-air target detection, and
3. Only a slight reduction (5-10 percent) in weather clutter target detection.

These improvements are measured in reference to performance of the CD with ACE 3 curve selected. Ideally, these measurements should be made using a wide variety of video samples. These samples should include several radar types, many weather situations, varying ground clutter patterns, and both logarithmic (log) and moving target indicator (MTI) videos. Unfortunately, there was neither the time to undertake this extensive testing nor the availability of the many video samples required. The testing of the correlation sensitive ACE was therefore restricted to five video samples from the air route surveillance radar (ARSR-2) at Elwood, New Jersey. This drastic limitation in the number of video samples leaves many questions unanswered. To fully evaluate the effectiveness of correlation-sensitive ACE techniques, a full-scale test using all the aforementioned video samples must be performed. The test data from the Elwood radar can serve only as an indication of the potential of the ACE modification.

### HARDWARE VERIFICATION.

The first tests performed on the correlation estimation ACE were run to assure proper performance of the hardware. Built-in test equipment in both the N1, N11 chassis and the T<sub>L</sub> chassis were used to verify internal operation.

Fixed-hit patterns generated on a test card in the N1, N11 chassis exercised all the circuits necessary to generate the number of hits in the window and the number of pairs of hits in the window. These sums of hits and pairs were then used to validate the lead edge generated by the T<sub>L</sub> chassis. The fixed-hit patterns generated by the test card included an all "1" pattern, a checkerboard pattern, alternating pairs, and all zero's.

A further hardware verification was performed by configuring the ACE modification to simulate the conventional CD ACE circuit. This was done by reprogramming the hardware to include the cell of interest into the ACE window counts and to program the lead edge criteria to be a function only of the number of hits in the ACE window. Performance in this simulated CD ACE mode was checked to assure that the hardware was performing in a manner similar to the CD.

### 8x12 WINDOW EVALUATION.

The first range, azimuth window size selected for evaluation was an area, 8 range cells by 12 triggers. This conforms to the standard window size in the Elwood CD. This window size was chosen so that any data obtained could be directly compared to the standard ACE data of the same window size. At first, several different lead edge curves were used to determine the effect the correlation estimator had on false target detection. The initial curves were based on the results of MITRE simulation work.

To evaluate the effect of the curve, a video tape of log video was replayed into the CD and the CD with the modified ACE circuit. The video tape was recorded during heavy rain showers. A ring of 32 radiofrequency (RF) test targets were inserted into the directional coupler, each scan using a test target generator. These test targets were mixed into the storm area and used to check detection in weather clutter areas.

For this test, two measurements were recorded. First, the search data count (SDC) was obtained by using an electronic counter. Next, the digital output messages from the CD were recorded on a digital tape recorder. Two sets of recordings were made, one in the modified and one in the unmodified configuration. These tapes were then replayed into a simplex 9020 computer. The COMDIG program was used to collect data on the probability of detection ( $P_d$ ) for the ring of test targets. The results of these first tests are shown in table 1.

The search data counts made from the modified and the unmodified CD indicated a decrease of 24.9 percent using the correlation estimator. However, the average  $P_d$  using the modified ACE was reduced by 25.0 percent as compared to the standard CD. Several attempts to adjust the curves with the 8x12 window were attempted, but each time the reduction in SDC was matched by a reduction in  $P_d$ . It was at this point that MITRE reinitiated their simulation efforts utilizing larger ACE windows. At the conclusion of their investigation, it was suggested that a series of tests be conducted using large ACE windows in the hardware.

The first test run with larger window sizes consisted of replaying a weather tape into the correlation estimator which was consecutively configured for an 8x12, 16x12, 24x12, or 30x12 ACE window. The window was increased in the range dimension only. For each of the different ACE window sizes, the SDC was recorded for the same 5-minute time period. The SDC numbers are presented in table 2. The percent reduction in SDC obtained from this test agreed with the trends established in the MITRE simulations. The MITRE simulations revealed that detection was optimized for the 24x12 window size. Therefore, a window size of 24x12 was chosen for further hardware testing.

### CURVE OPTIMIZATION.

After the selection of a 24x12 window for further testing, an attempt was made to optimize the theoretical lead edge curve used in the MITRE simulations.

TABLE 1. PROBABILITY OF DETECTION RESULTS USING 8x12 WINDOWS

Target Number	PROBABILITY OF DETECTION	
	CD/ACE 3 (Percentage)	CD/CORRELATION ESTIMATOR UNIT (Percentage)
1	70.0	43.3
2	66.7	60.0
3	88.3	55.0
4	55.0	23.3
5	45.0	25.0
6	53.3	25.0
7	73.3	40.0
8	71.7	38.3
9	43.3	18.3
10	28.3	11.7
11	98.3	90.0
12	100.0	100.0
13	100.0	100.0
14	100.0	96.7
15	98.3	58.3
16	50.0	23.3
17	63.3	15.0
18	80.0	53.3
19	98.3	70.0
20	100.0	81.7
21	100.0	85.0
22	100.0	96.7
23	98.3	61.7
24	98.3	58.3
25	93.3	66.7
26	86.7	31.7
27	90.0	30.0
28	86.7	56.7
29	76.7	58.3
30	93.3	51.7
31	73.3	43.3
32	50.0	41.7
Average $P_d$	79.0	54.0

One source of additional information was test data on the statistical makeup of a 24x12 window. Since many tests of quantizers had revealed the regulation of hits in clear air or weather clutter, it was considered necessary to measure the number of pairs of hits in a window of 24x12. Test points within the correlation-sensitive ACE were monitored, and a table showing the frequency of occurrence of a certain number of pairs in a particular window size was made. The inputs for the test included a random noise generator, the clear-air portion of a video tape, and the weather clutter portion of a videotape. Table 3 lists the results from this testing. An examination of the table reveals that the number of azimuth pairs of hits in the ACE window is very dependent on the video input. The table shows that any time there is a count of six or more pairs in the window, there is a very good chance it is a weather clutter area. These data were used to tailor the theoretical curves for optimum false target elimination in weather clutter without affecting clear-weather  $P_d$ .

TABLE 2. REDUCTION IN SEARCH DATA COUNT USING VARIOUS WINDOW SIZES

<u>Window Size</u>	<u>SDC</u>	<u>Percent Reduction</u>
8x12	2,686	49.9
16x12	1,760	67.1
24x12	1,489	72.2
30x12	1,338	75.0
CD ACE 3	5,362	-

TABLE 3. FREQUENCY OF OCCURRENCE OF PAIRS IN THE CLUTTER SUM WINDOW (24x12)

<u>Number of Pairs</u>	<u>Random Noise Generator Input (Percentage)</u>	<u>Clear-Air Area (Percentage)</u>	<u>Weather Clutter Area (Percentage)</u>
1	50.1	34.5	94.9
2	17.8	8.7	88.0
3	5.4	2.1	77.9
4	2.0	0.7	68.7
5	1.1	0.5	60.1
6	-	0.4	50.1
7	-	0.3	39.4
10	-	0.1	21.3
15	-	-	5.8
20	-	-	1.2

Note: Thermal  $P_N = 5.0$  percent  
 Clutter  $P_N = 8.0$  percent

### 24x12 ACE WINDOW TESTS.

The testing of the lead edge curve using an 24x12 window area was divided into two areas of accomplishment. First, five video tapes of quantized hit data were recorded on tape. This was performed using two tape recorders as shown in figure 3. The prequantized tapes were used to eliminate any changes in the analog CD quantizer from affecting the test results.

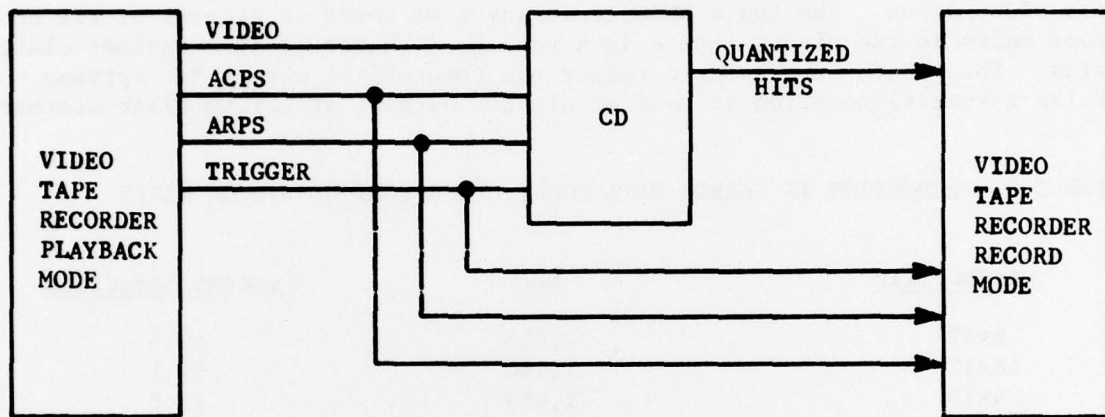

76-40-3

FIGURE 3. EQUIPMENT CONFIGURATION FOR RECORDING QUANTIZED HITS FROM THE CD

Next, the five tapes were replayed into the CD. The CD outputs were recorded on a digital tape recorder in building 149, NAFEC. A second replay of the quantized video tapes was made with the correlation estimator unit replacing the standard ACE 3 circuits. These output messages were recorded on another digital tape recorder. These tapes were then used as input to the central computer complex (CCC) for tracking and display. Search target tracks on targets of opportunity were initiated in areas free of weather clutter and on targets in clear air proceeding into weather clutter. The same targets were tracked on both the modified and the unmodified system. All five pairs of digital tapes were analyzed in a similar manner. A comparison of the  $P_d$  data obtained for three of the tapes is presented in tables 4, 5, and 6.

TABLE 4. TAPE 76-06 P<sub>d</sub> RESULTS

Target Number	Scans Tracked	Probability of Detection	
		CD/ACE 3	CD/Correlation Estimator
(Percentage)			
1	65	89.2	90.8
2	65	56.9	61.5
3	37	73.0	81.1
4	54	94.4	94.4
5	39	97.4	97.4
6	85	92.9	94.1
7	73	93.2	91.8
8	18	72.2	94.4
9	15	93.3	93.3

TABLE 5. TAPE 74-07 P<sub>d</sub> RESULTS

Target Number	Scans Tracked	Probability of Detection	
		CD/ACE 3	CD/Correlation Estimator
(Percentage)			
1	45	56.0	60.0
2	54	81.5	88.9
3	57	96.5	87.7
4	36	91.7	91.7
5	63	84.0	93.7
6	36	94.4	94.4
7	34	97.1	97.1
8	64	90.6	92.2
9	42	83.3	97.1

TABLE 6. TAPE 74-13 P<sub>d</sub> RESULTS

Target Number	Scans Tracked	Probability of Detection	
		CD/ACE 3	CD/Correlation Estimator
(Percentage)			
1	59	78.0	78.0
2	62	95.2	100.0
3	34	100.0	97.1
4	69	95.7	87.0
5	61	72.1	70.5
6	47	74.5	95.7
7	41	100.1	100.0
8	21	85.7	90.5
9	83	94.0	94.0
10	82	98.8	90.2
11	73	94.5	90.4

While the digital recordings were being made, a count of the search targets declared was made for a 5-minute period on each tape. The same 5-minute period was counted for both the modified and unmodified systems. These SDC's are an indication of the relative false data rates for each system. These data are depicted in table 7.

TABLE 7. SEARCH DATA COUNT RESULTS

<u>Tape Number</u>	<u>SEARCH Targets CD/ACE 3</u>	<u>CD/Correlation Estimator</u>	<u>Reduction Using Correlation Estimator (Percentage)</u>
74-07	10,300	6,800	-34
74-13	5,600	4,144	-26
76-06 Log	5,925	5,239	-11.6
75-12	2,130	1,950	- 8.5
76-06 MTI	2,500	2,600	+ 4.0

This table shows a relative decrease in SDC from 34 to 8.5 percent for log video and an increase of 4 percent for MTI video. The tables summarizing  $P_d$  for these same tapes demonstrate no measurable loss of target detection using the correlation estimator unit.

## SUMMARY OF RESULTS

1. The correlation-sensitive ACE unit effectively interfaced with the CD to provide lead edge information based on the number of hits and the number of azimuth hit pairs within the ACE window area.
2. The initial tests using an ACE window of eight range cells by 12 radar sweeps resulted in reductions in both the probability of false alarm ( $P_{fa}$ ) and the probability of detection ( $P_d$ ) of true aircraft.
3. Attempts to optimize the lead edge curve for the 8x12 window were unsuccessful. Each attempt to reduce  $P_{fa}$  resulted in a corresponding loss of  $P_d$ .
4. The tests measuring the frequency of occurrence of azimuth pairs of hits in the ACE window demonstrated that pair measurements are a positive indicator of the presence of correlated search radar returns (i.e., weather clutter, ground clutter).
5. The lead edge curve design techniques used by MITRE resulted in a greater reduction in  $P_{fa}$  when larger ACE window sizes were tested.
6. The correlation estimator unit using a 24x12 window reduced the search data count from 8 percent to 34 percent on four samples of weather clutter returns. These returns were recorded from the log video channel of the ARSR-2 radar.
7. Target detection for the four log weather samples was comparable for both the modified and the unmodified CD.
8. One sample of MTI video recorded from the ARSR-2 radar yielded a 4-percent increase in the search data count when the modified ACE circuits were compared to the performance of the CD/ACE 3. Target detection was equal for the CD/ACE 3 and the CD/correlated ACE unit (24x12 window).

## CONCLUSIONS

It is concluded that:

1. An ACE window of 8 range cells by 12 triggers is of insufficient size to effectively incorporate correlation estimation techniques.
2. A reduction of 10 to 30 percent in search false alarms with no reduction in true aircraft detection is possible using the correlation estimator unit.
3. Curve optimization for the correlation estimator unit is extremely arbitrary. Results indicate that the curve selection may be dependent on the type of radar, video characteristics, quantizer performance, and the amount of actual radar clutter correlation.

## RECOMMENDATION

The NAFEC test results clearly indicate that second-threshold control based on azimuthal correlation is effective in controlling the false alarm rate. However, a further evaluation of these techniques is necessary at field sites where search false targets due to weather clutter are a significant problem. It is recommended that a modified target detection group (TDG) incorporating correlation estimation techniques based on the specifications developed for the design of the NAFEC correlation estimator unit be installed for a long-term field evaluation.

## REFERENCES

1. Sinha, L. P., Radar Target Detection Employing On-Line Estimation of the Video Correlation, MTR-4240, FAA-RD-74-164, May 1974.
2. Lefferts, R. E., Performance of a Correlation-Sensitive Radar Detection Technique, MTR-7202, FAA-RD-76-133, May 1976.