

AD-A037 140

NAVAL RESEARCH LAB WASHINGTON D C
MARKING THE SEA SURFACE WITH ARTIFICIAL SEA SLICKS AND FLUORESC--ETC(U)
JUL 76 W R BARGER, W D GARRETT

F/G 13/2

UNCLASSIFIED

USCG-D-107-76

NL

| OF |

AD
A037140



END
DATE
FILMED
4-77

REPORT NO. CG-D-107-76 ✓

12

MARKING THE SEA SURFACE WITH ARTIFICIAL SEA SLICKS AND FLUORESCENT DYES TO AID
SEARCH AND RESCUE OR OCEAN DUMPING SURVEILLANCE OPERATIONS

AD A 037140



JULY 1976

FINAL REPORT

Document is available to the U. S. public through the
National Technical Information Service,
Springfield, Virginia 22161

DDC
RECEIVED
MAR 18 1977
A

PREPARED FOR
U.S. DEPARTMENT OF TRANSPORTATION
UNITED STATES COAST GUARD
OFFICE OF RESEARCH AND DEVELOPMENT
WASHINGTON, D.C. 20590

NOTICE

This document is disseminated under the sponsorship of the Department of Transportation in the interest of information exchange. The United States Government assumes no liability for its contents or use thereof.

The United States Government does not endorse products or manufacturers. Trade or manufacturers' names appear herein solely because they are considered essential to the object of this report.

The contents of this report do not necessarily reflect the official view or policy of the U. S. Coast Guard and do not constitute a standard, specification, or regulation.

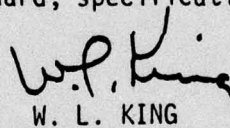

W. L. KING
Captain, U. S. Coast Guard
Chief, Environmental and
Transportation Technology Division
Office of Research and Development
U. S. Coast Guard
Washington, D. C. 20590

ADDITIONAL INFO		
RTIC	<input checked="" type="checkbox"/>	
DDC	<input type="checkbox"/>	
USANDP/USNS	<input type="checkbox"/>	
JUSTIFICATION		
BY		
DISTRIBUTION AVAILABILITY CODES		
OCC. EVAL. COPY PLUM		
A		

1. Report No. 18 US CG D-107-76		2. Government Accession No.		3. Recipient's Catalog No. 11	
6. Marking the Sea Surface With Artificial Sea Slicks and Fluorescent Dyes To Aid Search and Rescue for Ocean Dumping Surveillance Operations		Report Date JULY 1976		Performing Organization Code	
7. Author(s) 10 William R. Barger and William D. Garrett		8. Performing Organization Report No. 1280 P. 1		10. Work Unit No. (TRAMS) 4205.1/3	
9. Performing Organization Name and Address Chemical Oceanography Branch Naval Research Laboratory Washington, D. C. 20375		11. Contract or Grant No. MIPR Z-70099-5-53378		12. Type of Report and Period Covered 9 FINAL REPORT	
12. Sponsoring Agency Name and Address U. S. Department of Transportation U. S. Coast Guard Office of Research and Development Washington, D. C. 20590		14. Sponsoring Agency Code		15. Supplementary Notes	
16. Abstract A new technique of marking the ocean surface with monomolecular films in combination with dyes was studied in order to develop a practical sea marker which can be detected by airborne remote sensing devices in addition to visual observation. Monomolecular films of surface-active chemicals damp capillary waves on a body of water and can be used to make marks that are detectable day or night by radar. The area of damped waves is also visible to the eye even though the single-molecule-thick film itself is too thin to be seen. Since the film is so thin, a very small amount of material can be used to cover a large area on the sea surface with a detectable mark. Several water-soluble fluorescent dyes were examined, and uranine was chosen for use in the combined seamarker package. A prototype package for a hand-held marker which dispenses both dye and monolayer-forming chemicals was designed and tested in the field. Based on the laboratory and field data a series of mathematical equations was developed to approximate the shapes, sizes and lifetimes of monolayer slicks under different wind conditions. These equations allow the proper amount of monolayer-forming material to be chosen to make a mark of desired size or lifetime. Practical seamarkers using monolayer-film-forming chemicals in combination with water-soluble fluorescent dyes can be produced for marking objects or activities on the sea surface. The information in this report can be used to produce a dye/slick seamarking device tailored to a specific need.					
17. Key Words surface films sea markers search and rescue dye markers pollution monitoring sea slicks			18. Distribution Statement Document is available to the U. S. Public through the National Technical Information Service, Springfield, Virginia 22161		
19. Security Classif. (of this report) UNCLASSIFIED		20. Security Classif. (of this page) UNCLASSIFIED		21. No. of Pages 80	22. Price

251950 dn

TABLE OF CONTENTS

<u>Section</u>	<u>Page</u>
I. Introduction.	1
II. Materials Investigated.	2
II.1 Water-Soluble Fluorescent Dyes	3
II.2 Surface-Active, Artificial Sea-slick Forming Chemicals.	4
II.3 Oil-Soluble Fluorescent Dyes	6
III. Laboratory Studies of Selected Chemicals.	7
III.1 Force-Area Curve of Oleyl Alcohol.	7
III.2 Dye Mark Sizes and Theoretical Average Concentrations of Water-Soluble Dyes	8
III.3 Laboratory Studies of Uranine Dye Fluorescence	11
III.4 Effects of Strong Acids and Bases on Uranine Dye	16
III.5 Films Containing Oil-Soluble Dyes.	20
IV. Prototype Dispensing Devices.	22
IV.1 Hand-held Dye/Slick Marker Prototype Dispensing Device	22
IV.1.1 Explanation of Canister Parts	24
IV.1.2 Directions for Use of the Dye/Slick Marker.	25
IV.2 Multiple, Single Point Dispensing Device Prototype	25
IV.3 Prototype Chemical Dispenser with Constant Flow Rate	29
V. Field Studies of Selected Dyes and Slick-Forming Chemicals	32
V.1 Field Test No. 1: June 5, 1975 - Chesapeake Bay.	32
V.2 Field Test No. 2: August 19, 1975 - Chesapeake Bay	35
V.3 Field Test No. 3: September 25, 1975 - Atlantic Ocean.	36
V.3.1. Determination of Slick Length from Photographs.	38

TABLE OF CONTENTS CONTINUED

<u>Section</u>	<u>Page</u>
V.3.2. Determination of Slick Widths from Photographs.	40
V.4 Field Test No. 4: May 19, 1976 - Pacific Ocean	44
V.5 Field Test No. 5: May 21, 1976 - Pacific Ocean	45
VI. Factors Affecting the Growth and Dissipation of Monolayer Slicks.	47
VII. Mathematical Approximation of Monolayer Behavior.	50
VII.1 Single Point Dumping	50
VII.1.1 Linear Spreading in a Channel	50
VII.1.2 Wind Effects Determined from Field Data	53
VII.1.3 Area Covered as a Function of Time.	56
VII.1.4 Lifetimes of Oleyl Alcohol Marker Slicks.	57
VII.2 Dispensing Monolayer-Forming Chemicals from a Moving Vessel.	62
VII.2.1 Sample Computation for a Single Point Dump.	62
VII.2.2 Sample Computation for a 2-1/4 Mile Long Stripe	63
VII.3 Decreasing Film Pressure with Monolayer Expansion.	64
VIII. Summary	66
IX. Appendix I--Derivation of the Expression for Slick Area as a Function of Time	70
X. References.	71
XI. Acknowledgements.	73

LIST OF FIGURES

<u>No.</u>		<u>Page</u>
1.	Force-Area Curve for Oleyl Alcohol.	9
2.	Fluorescence Spectrum for 1 ppm Uranine Dye in Seawater	13
3.	Fluorescence Spectrum for 1 ppm Uranine Dye in Seawater Shaken with Oleyl Alcohol	14
4.	Fluorescence Spectra for Oleyl Alcohol, Seawater, and Distilled Water .	15
5.	Absorbance Spectra for Uranine in Distilled Water, in Acid Solution, and in Basic Solution	19
6.	Prototype Hand-held Dye/Slick Marker.	23
7.	Prototype Multiple, Single-Point Dispensing Device.	26
8.	Float Valve Modifications for Multiple Dumping Device	28
9.	Constant Flow Rate Chemical Dispenser Prototype	30
10.	Photograph of 150 gram and 3 liter Oleyl Alcohol Slicks from 500 ft . .	39
11.	Method of Determining Slick Lengths from Photographs.	41
12.	Method of Determining Slick Widths from Photographs	42
13.	Factors Affecting the Growth and Dissipations of a Monolayer Slick. . .	48
14.	Predicted Lifetimes of Given Amounts of Oleyl Alcohol Dumped at a Single Point.	60
15.	Sizes, Shapes, and Lifetimes Predicted for 150 gram Oleyl Alcohol Slicks Under Different Wind Conditions.	61

LIST OF TABLES

<u>No.</u>		<u>Page</u>
1.	Acid and Basic Solutions Containing 10 ppm Uranine Dye.	17
2.	Marks Made by Candidate Sea Marking Materials on the Chesapeake Bay . .	36
3.	Spreading Rate Equation Constants for Several Monolayer-Forming Chemicals	51
4.	Data for Computation of Slick Lengthening Rate Due to Wind Alone. . . .	55
5.	Predicted and Measured Characteristics of Marker Slicks of September 25, 1975.	59

I. Introduction

The U. S. Coast Guard Office Of Research and Development has an extensive program underway to develop airborne remote sensing devices for the detection of oil spills.¹ The Coast Guard's prototype Airborne Oil Surveillance System (AOSS) presently includes such sensing devices as infrared and ultraviolet line scanners, passive microwave imagery, low light level television, and side looking airborne radar. Since this airborne remote sensing package will be available in the near future to detect spilled oil, the means will exist for detecting slicks made deliberately on the sea surface for search and rescue purposes. The accepted method of marking the sea surface up to the present time has been to simply release a dye that is visible to the eye during daylight. However, with the development of the AOSS aircraft the possibility exists of detecting surface marks at night or under poor weather conditions when the marks might not be visible to the eye alone. If deliberate surface marks could be detected at night or through a heavily overcast sky, Coast Guard search and rescue missions would be aided by the use of such markers and might save lives that would otherwise be lost. Surface marks detected by airborne remote sensing devices could also be used to keep track of the location of activities on the sea such as permitted ocean dumping.

The development of a remote sensing device which employs a laser to cause fluorescence of a sea dye mark so that it can be detected from the air at night has been initiated, while it is already well known that certain types of radar can detect the absence of sea clutter return due to the damping of capillary waves by oil. Research on natural sea slicks at the Naval Research

Laboratory in the past has shown that films only one molecule thick can be applied to the sea surface to damp capillary waves.² With the above thoughts in mind a project to develop an improved technique of marking the sea surface was initiated at the Naval Research Laboratory. The objectives of the project were:

- (1) to identify optimum sea slick/fluorescent dye combinations which maximize the reduction of radar sea clutter, the slick area-to-volume ratio, and the persistency or durability of both an identifiable fluorescent tag and a radar-detectable sea slick,
- (2) to provide samples of the fluorescent sea slick materials for Coast Guard field tests with airborne laser and radar sensor systems,
- (3) to develop procedures and to propose mechanisms for adequate dispersal and metering of the sea slick for both search and rescue as well as ocean dumping surveillance applications,
- (4) to determine those sea slick materials which are most resistant to the types of waste discharged by ocean dumping vessels.

II. MATERIALS INVESTIGATED

To accomplish the goals of the project a series of laboratory and field tests were performed using materials that showed promise as possible marking agents. Three types of materials were investigated:

- Type 1: Water-soluble dyes that are fluorescent when dissolved in water,
- Type 2: Surface-active chemicals capable of forming an insoluble single-molecule-thick surface film on water which remains coherent and damps out capillary waves,
- Type 3: Oil-soluble dyes that are fluorescent when dissolved in oil.

All of these materials possess two criteria thought necessary for a practical improved seamarker. They are optically visible through either light reflection patterns or fluorescence, and they are sensible by an electromagnetic detector such as radar, ultraviolet, or infrared.

The general strategy of this investigation was to move forward as rapidly as possible to detailed laboratory and field testing of the first choice water soluble dye (uranine) and the first choice surface film forming chemical (oleyl alcohol) coming back to do detailed studies of the second or third choices in each category only if problems were encountered with the first choices. Both first choice materials have been extensively studied in the past. Oil-soluble fluorescent dyes have not been investigated as possible sea marking materials in the past, and therefore it was necessary to examine several of them before reaching a decision on the practicality of their use.

II.1 Water Soluble Fluorescent Dyes

Dyes that are fluorescent when dissolved in water have been used extensively in the past for marking the sea or tracing streams of water. Much previous laboratory data has been gathered on such dyes,^{3,4} and a brief evaluation of several of the dyes of this type as sea markers was carried out for NASA in 1964 as a part of a study of visual location aids for space capsules landing in the sea⁵. Based on the work reported by others and on our own past experience with sea markers^{6,7}, three powdered dyes of the water-soluble, fluorescent type were selected for further study:

- 1) Uranine, the sodium salt of fluorescein
- 2) Rhodamine-B
- 3) Rhodamine-6G

The Uranine was obtained as laboratory grade, No. A-833, from the Fisher Scientific Co., Chemical Manufacturing Division, Fair Lawn, N. J. The Rhodamine-B, No. P4453, and Rhodamine-6G, No. 10724, were obtained from Eastman Kodak Co., Rochester, N.Y. Since the chemical formulas of these dyes are documented in both reference 3 and reference 4, they will not be repeated here.

II.2 Surface-Active, Artificial Sea-Slick Forming Chemicals

For more than 15 years the Naval Research Laboratory has had an active research program to study natural slicks on the ocean and useful applications of sea slicks created with chemicals found by laboratory studies to make ideal artificial slicks. The ideal type materials for creating artificial sea slicks are quite different than the spilled pollutant petroleum oils which are first thought of when slicks are mentioned. The results of earlier research showed that natural sea slicks contain surface-active chemicals^{8,9} which form layers actually only one molecule thick. The best materials for forming artificial sea slicks also have the property of autophobicity which means that they will not spread over their own monomolecular layer. Therefore, they do not form thick layers, but spread spontaneously as a single-molecule-thick film away from the bulk droplets of the material placed on a water surface. What is seen by the eye when such a chemical spreads over the sea surface is not the chemical itself, but the region of damped out capillary waves caused by the adsorption of the chemical on the surface skin of the water. Capillary waves are the tiny wrinkles of less than 1.7 cm wavelength that cover the larger waves on clean water in all cases except during a dead calm. When the surface-active chemical is adsorbed at the water surface, the surface tension of the water is reduced, and

capillary waves cannot be propagated as far as in clean water. Surprisingly, it was discovered that the maximum damping effect is achieved when surface tension is reduced by only about 1 dyne/cm below the value for clean water (72 dynes/cm for distilled water; 73 dynes/cm for seawater). This means that the molecules in an ideal, wave-damping, single-molecule-thick layer do not even have to be very close together to cause capillary wave damping. More details of the characteristics of the artificial sea slick forming chemicals will be given later in the report, but the practical result of all this data is that very small quantities of a properly chosen chemical can make extremely large visible marks on the sea surface. Certain types of radar can also detect these marks since the absence of sea clutter is sensed. Two chemicals that form single molecule thick surface films and which have been studied extensively in the past were chosen for further investigation:

1) Oleyl alcohol, (cis-9-octadecen-1-ol)

and 2) Sorbitan monooleate.

Previous work^{2,6,7} at the Naval Research Laboratory suggested the use of the chemical oleyl alcohol to mark the sea surface, so this material was obtained in cosmetic grade as ADOL-85 from the Ashland Chemical Co., Columbus, Ohio, for further study. The other compound, sorbitan monooleate, brand name SPAN-80, obtained from ICI United States, Wilmington, Del. was also considered because of its previous study and use for controlling oil spills.¹⁰

The following selection criteria pertain to seamarker suitability of slick-forming chemicals.

1. Liquid, easily and rapidly spread onto water,

2. Nonvolatile, relatively high molecular weight,
3. Nonionic, little reaction with salt water,
4. Low water solubility due to large size of hydrophobic alkyl group.
5. Forms expanded liquid-like monolayer, little hysteresis, high spontaneous spreading rate,
6. Low freezing point,
7. Highly surface-active, equilibrium spreading pressure greater than 30 dynes/cm, intense capillary wave damping,
8. Commercially available at reasonable cost,
9. Noncorrosive, nontoxic.

The above criteria are necessary to provide a monolayer-forming sea surface marker which is easily applied, persistent, highly detectable, environmentally safe, and reasonable in cost.

II.3 Oil-Soluble Fluorescent Dyes

Although it was eventually decided that two separate marks, one made by a slick and one made by a dye were better than a single "fluorescent slick", the possibility of creating a combination effect was investigated. Water-soluble dyes diffuse downward into the water at the same time they are spreading over the surface, so much of the material does not remain near the surface where it can be sensed by the eye or electromagnetic devices. It is possible to make oil slicks from oil in which fluorescent dye is dissolved. By spreading such an oil on the sea surface, the capillary waves will be damped to make a radar sensible mark, and at the same time the oil will hold the fluorescent material on the sea surface so that it cannot diffuse downward as rapidly as a water-soluble dye. A petroleum derived oil which itself is fluorescent could be used as the solvent for a fluorescent dye. Six oil-soluble fluorescent dyes were obtained from the Morton Chemical Co., Chicago,

in order to prepare fluorescent oil slicks for further study:

- 1) Fluorescent Yellow C6
- 2) Fluorescent Yellow FG
- 3) Fluorescent Yellow G
- 4) Fluorescent Yellow 50
- 5) Fluorescent Yellow 131
- 6) Fluorescent Yellow 131SC

Laboratory studies of these dyes are considered in section III.5.

III. LABORATORY STUDIES OF SELECTED CHEMICALS

III.1 Force-Area Curve of Oleyl Alcohol

The area covered by a single-molecule-thick film of an insoluble, surface-active material can be determined easily in the laboratory as a function of the film pressure. Film pressure is the difference in the surface tension of clean water and water covered by a monolayer film which reduces surface tension. The curve showing the relationship of area covered by a given amount of film-forming chemical to the film pressure is called a force-area curve. A region on the sea surface which has a lower surface tension than the surrounding region will be visible to the eye because of the absence of capillary waves due to damping. A force-area curve can indicate the amount of material required to make a mark on the sea of a given size. The force-area curve for oleyl alcohol was therefore determined in the laboratory.

Briefly, a shallow, paraffin-coated tray of known area was filled with distilled water and an extremely small, accurately known quantity of oleyl alcohol was added to the surface. Less material was added to the surface than would be required to cover it with an expanded monolayer. The surface tension of the water was measured carefully by the Wilhelmy Plate method using a $1 \text{ cm}^2 \times .005 \text{ cm}$ platinum plate hanging from a recording electrobalance. A

paraffin-coated bar placed across the tray was moved by a screw drive to reduce the surface area available for the monolayer to cover. The surface concentration of the oleyl alcohol was therefore increased which caused a decrease in the surface tension which is equivalent to an increase in the film pressure. A film pressure of zero dynes/cm indicates a clean water surface. The change in film pressure was recorded on a strip-chart recorder as the area covered by the film was reduced. The resulting force-area curve is shown in Figure 1. This curve indicates the ideal maximum coverage possible on calm, distilled water. In the field, less than ideal coverage is achieved as will be shown later in this report. However, field experience has shown that very small quantities of oleyl alcohol can make extraordinarily large marks.

III.2 Dye Mark Sizes and Theoretical Average Concentrations of Water Soluble Dyes

The theoretical size of a mark created by water soluble dyes is also of interest when investigating materials for making sea markers. If it is assumed that diffusion of a dissolving dye marker placed at a point on a perfectly still sea surface proceeds at the same rate in all directions away from the point, an imaginary hemispherical bowl of water which grows larger with time will contain all the dye. If a given amount of dye is added to a point on the surface, the diameter of the circular cross section of the imaginary hemisphere as seen from the air can be computed as a function of the average concentration of dye within the hemisphere of water to give an estimate of the size of the area expected to be marked by dye of a given concentration. For example, one might want to approximate the area that would be covered by a dye solution of 1 part per million average concentration if 100 grams of dye were dumped on the sea. For an average concentration of 1 ppm to be

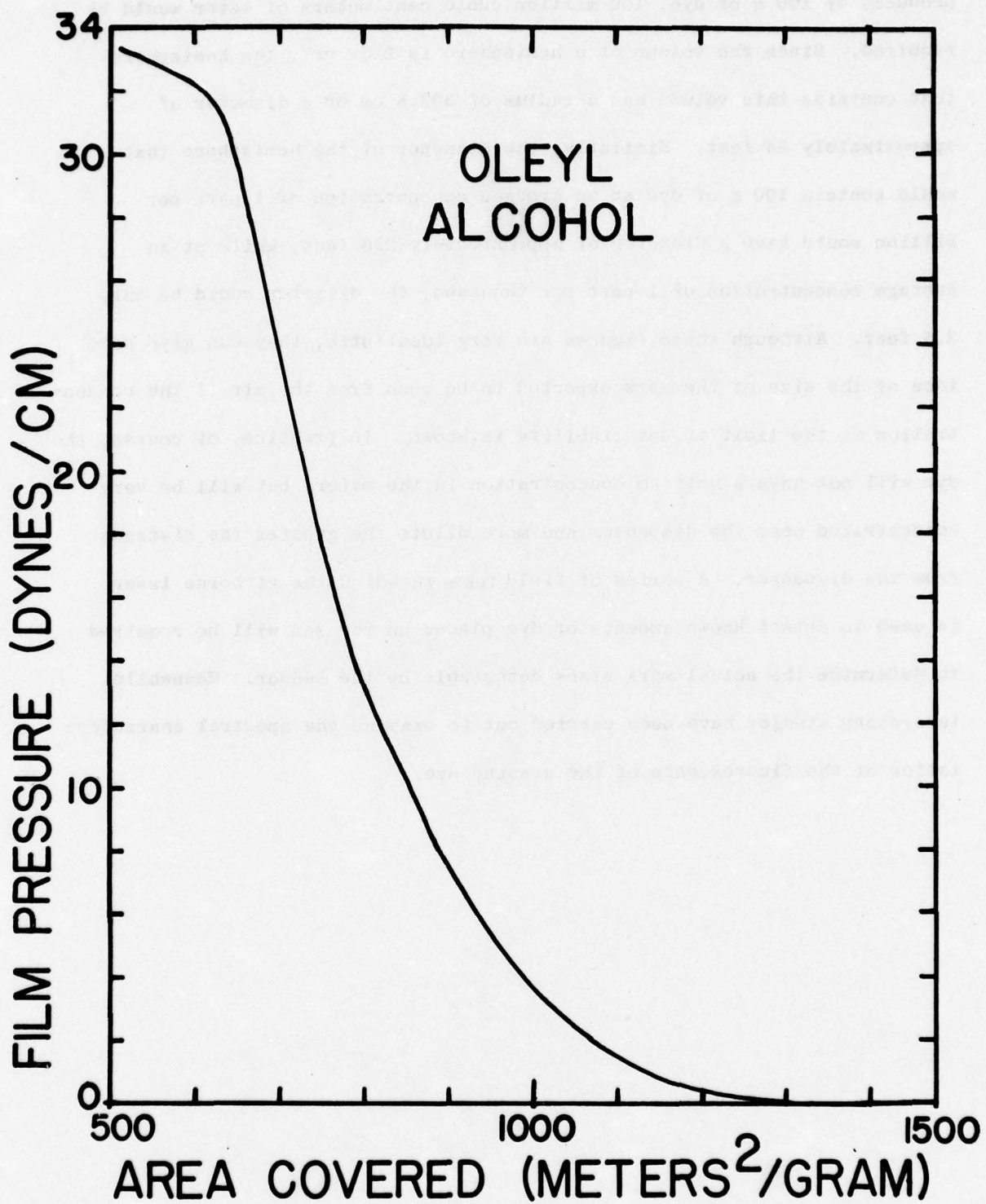

FIGURE 1. Force-Area Curve for Oleyl Alcohol

produced by 100 g of dye, 100 million cubic centimeters of water would be required. Since the volume of a hemisphere is $\frac{2}{3}\pi r^3$, the hemisphere that contains this volume has a radius of 362.8 cm or a diameter of approximately 24 feet. Similarly, the diameter of the hemisphere that would contain 100 g of dye at an average concentration of 1 part per billion would have a diameter of approximately 238 feet, while at an average concentration of 1 part per thousand, the diameter would be only 2.4 feet. Although these figures are very idealistic, they can give some idea of the size of the mark expected to be seen from the air if the concentration at the limit of detectability is known. In practice, of course, the dye will not have a uniform concentration in the water, but will be very concentrated near the dispenser and more dilute the greater the distance from the dispenser. A series of field tests in which the airborne laser is used to detect known amounts of dye placed on the sea will be required to determine the actual mark sizes detectable by the sensor. Meanwhile, laboratory studies have been carried out to examine the spectral characteristics of the fluorescence of the uranine dye.

III.3 Laboratory Studies of Uranine Dye Fluorescence

The purposes of the laboratory studies of the fluorescence of the uranine dye were to determine the characteristic spectrum of the emitted fluorescent light when the dye solution was excited by light of wavelength 337 nanometers (the wavelength of the light to be emitted by the laser sensor) and to determine if the slick forming chemical, oleyl alcohol, would alter the fluorescent signature of the dye in any way.

Five spectra were recorded using a Perkin-Elmer Fluorescence Spectrophotometer Model MPF-2A:

- 1) Distilled water,
- 2) Seawater of salinity 33.997 parts per thousand,
- 3) Oleyl alcohol,
- 4) Seawater containing 1 part per million uranine dye,
- 5) Seawater with 1 ppm uranine shaken with oleyl alcohol.

Solution No. 5 was prepared by adding 1 milliliter of oleyl alcohol to 5 milliliters of solution No. 4 and shaking vigorously. The bottom layer containing the dye was withdrawn and centrifuged for 5 minutes at 1500 rpm to assure that any suspended droplets of oleyl alcohol were removed. The solution appeared free of drops prior to being placed in the centrifuge. The spectrophotometer was operated at minimum sensitivity with a slit width of 10 nanometers. Solutions were placed in 1-centimeter-square cuvettes and the fluorescence was observed at a 90° angle to the incident light beam.

Spectral curves for the fluorescence of 1 ppm uranine in seawater and the same solution shaken with oleyl alcohol are shown in Figures 2 and 3 respectively. Comparing Figures 2 and 3 it is seen that they are essentially identical. No reaction between the oleyl alcohol and the uranine occurred to

reduce the intensity of the fluorescence or to shift the peak of the spectral intensity curve away from its maximum at 513 nanometers.

Figure 4 shows the fluorescence spectrum for distilled water, seawater, and pure oleyl alcohol. The pure oleyl alcohol shows some fluorescence at a wavelength of 513 nanometers, but the peak in fluorescence intensity is somewhere below 440 nm. It should be remembered, however, that the curve for oleyl alcohol was determined by sending the exciting beam through 1.000 cm of the pure chemical. In practice, when a dye/slick marker is released, the water surface will be covered by only a single-molecule-thick layer of oleyl alcohol below which the dye will lie dissolved in the water. The oleyl alcohol does not spread over its own monomolecular layer; excess material resides as small floating droplets spread thinly throughout the slicked area supplying material to the single-molecule-thick surface film as it grows in size. Referring back to the curve for oleyl alcohol reported in Figure 1, it is seen that even at full compression the concentration of material in the monomolecular slick is approximately 1 gram per 500 square meters of area. Since the density of oleyl alcohol is 0.8489 grams per cubic centimeter, the thickness of the fully compressed monolayer can be computed to be 2.4×10^{-7} centimeters or 2.4 nanometers. The layer is invisible to the eye because it is thinner than the wavelengths of visible light which lie in the 400 to 700 nanometer range. The curve in Figure 4 was produced by passing light of 337 nm wavelength through 10,000,000 nanometers (1 cm) of oleyl alcohol. A remote sensing device would see the dye solution through only 2.4 nanometers of the surface film. It can therefore be deduced that the dye's fluorescence will not be masked by the overlying monomolecular film when observed from above. Future field tests with the airborne laser sensor should be performed to confirm this deduction.

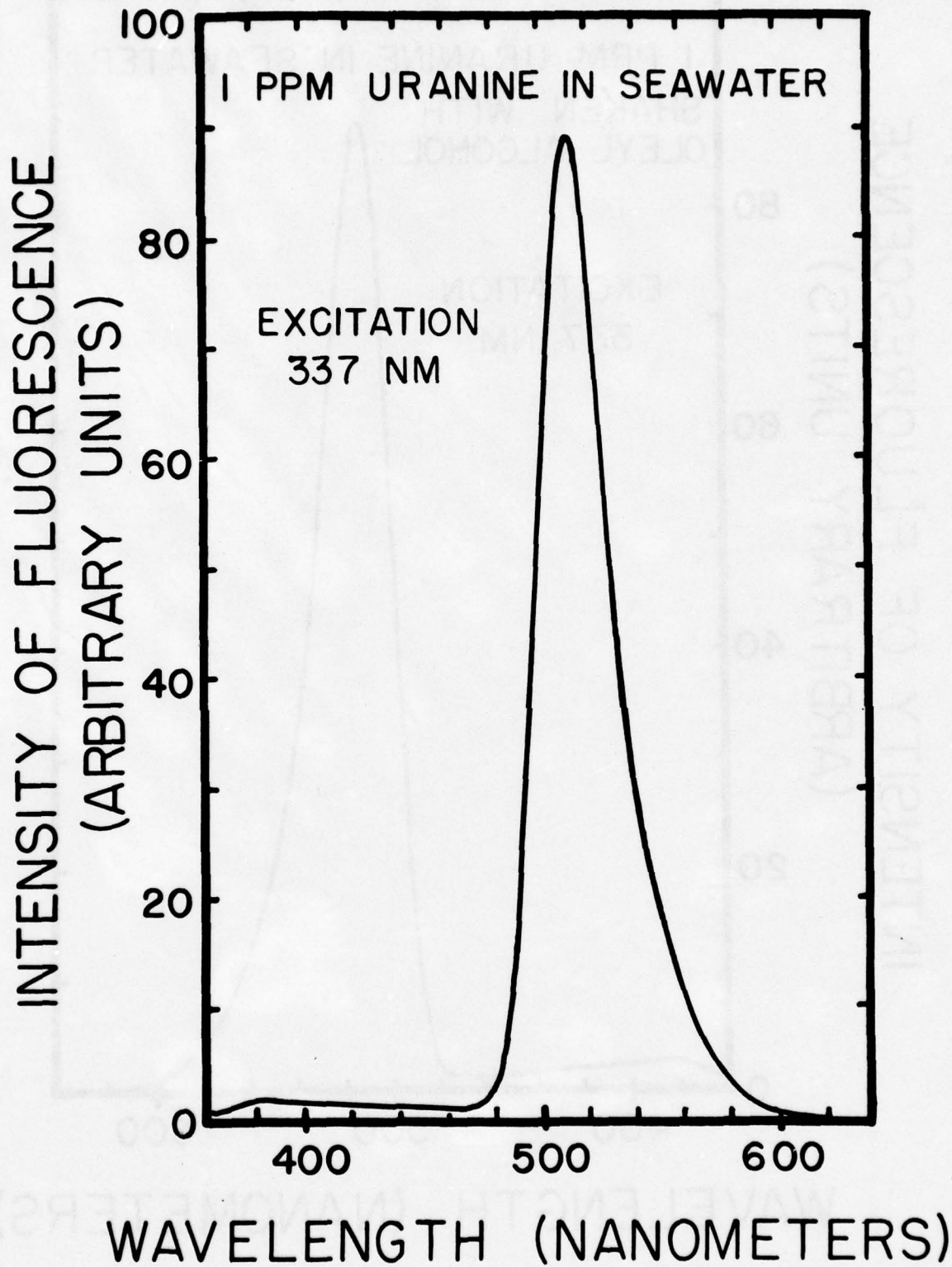

FIGURE 2. Fluorescence Spectrum for 1 ppm Uranine Dye in Seawater

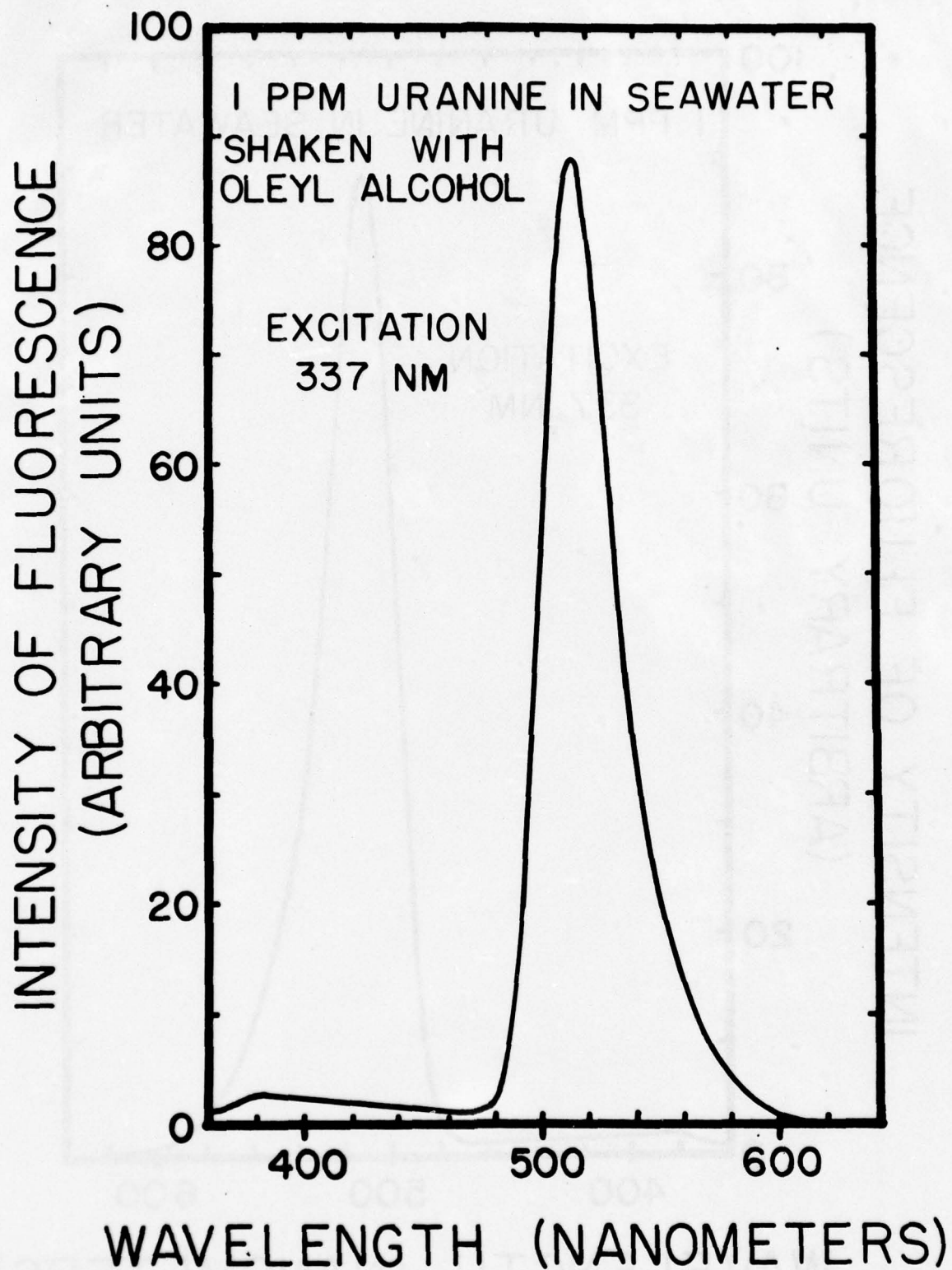

FIGURE 3. Fluorescence Spectrum for 1 ppm Uranine Dye in Seawater Shaken with Oleyl Alcohol

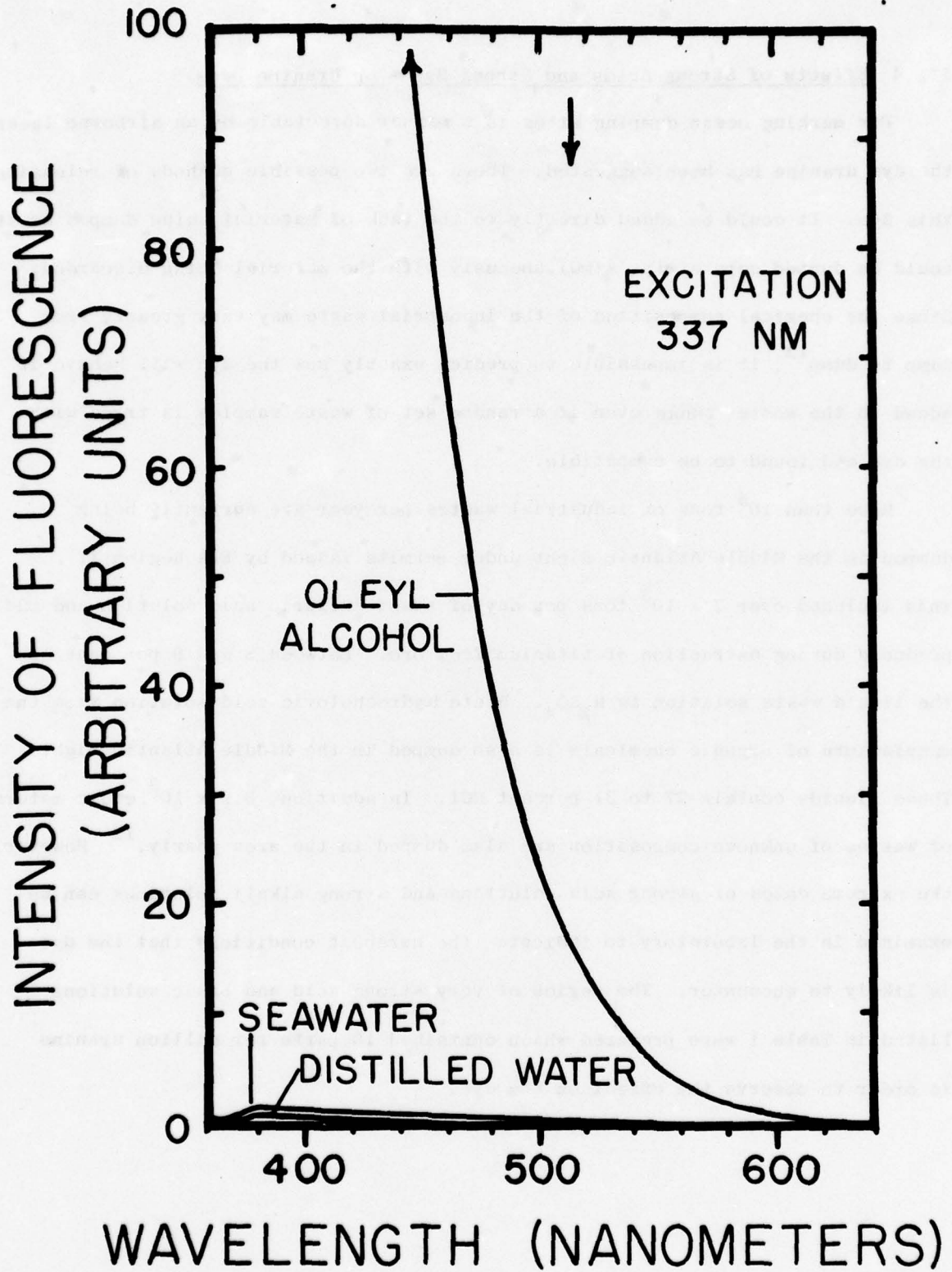

FIGURE 4. Fluorescence Spectra for Oleyl Alcohol, Seawater, and Distilled Water

III.4 Effects of Strong Acids and Strong Bases on Uranine Dyes

For marking ocean dumping sites in a manner detectable by an airborne laser, the dye uranine has been suggested. There are two possible methods of releasing this dye. It could be added directly to the tank of material being dumped or it could be dumped separately, simultaneously with the material being discarded. Since the chemical composition of the industrial waste may vary greatly from dump to dump¹², it is impossible to predict exactly how the dye will behave if added to the waste tanks even if a random set of waste samples is tried with the dye and found to be compatible.

More than 10^5 tons of industrial wastes per year are currently being dumped in the Middle Atlantic Bight under permits issued by EPA Region II. This included over 7×10^3 tons per day of spent sulfuric acid solution and mud produced during extraction of titanium from ore. Between 8 and 9 per cent of the liquid waste solution is H_2SO_4 . Waste hydrochloric acid solution from the manufacture of organic chemicals is also dumped in the Middle Atlantic Bight. These liquids contain 27 to 31 percent HCl. In addition, 8.9×10^3 cubic meters of wastes of unknown composition are also dumped in the area yearly.¹² However, the extreme cases of strong acid solutions and strong alkali solutions can be examined in the laboratory to indicate the harshest conditions that the dye is likely to encounter. The series of very strong acid and basic solutions listed in Table 1 were prepared which contained 10 parts per million uranine in order to observe the effect on the dye.

Table 1

Solutions Containing 10 Parts Per Million Uranine Dye

<u>Solute</u>	<u>% by Weight</u>	<u>Normality</u>
NaOH	20	5.00
KOH	20	3.56
Distilled Water	—	—
HNO ₃	20	3.17
H ₂ SO ₄	20	4.08
HCl	20	5.48

Under room lights the dye in the three acid solutions appeared less visible than in the distilled water and the alkaline solutions. These solutions were also observed under ultraviolet light in a dark room to determine the effect of the solutes on the fluorescence of the dye. The HCl and HNO₃ dye solutions exhibited no trace of fluorescence. The H₂SO₄ solution showed only a slight fluorescence. The two alkaline solutions appeared only slightly less fluorescent than the distilled water solution on the day that the solutions were prepared. However, after several days no fluorescence appeared in any of the solutions except the distilled water with dye, and all except the distilled water solution and the HCl solution became completely colorless under natural light. The HCl solution was only very slightly tinged yellow-green compared to the intense yellow-green color of the distilled water solution of uranine. The fluorescence did not return when the HNO₃ solution was neutralized, so the conclusion is that a chemical reaction with the dye occurred. Two other dyes were made up in 10 ppm concentrations in 20% HNO₃ and gave the same result:

the fluorescence under ultraviolet light was destroyed, and the solutions became colorless under natural light.

These same solutions were examined in a Varian-Techtron Model 635 UV-Visible Spectrophotometer to determine the absorbance of the solutions as a function of light wavelength. The results for the HCl, distilled water, and KOH solutions are shown as examples in Figure 5. Curve A is for the HCl solution; curve B is for the KOH solution, and curve C is for the solution of dye in distilled water. All three acid solutions shifted the peak absorbance to approximately 434 nanometers while the peak for the dye in distilled water is at about 477 nm, and the basic solutions shift it to 490 nm. The dye apparently takes one form in strongly acid solutions and another in strongly basic solutions, while under less extreme conditions it has an intermediate form. Kantardzhyan⁴ observed appreciable reduction in the intensity of the peak near 513 nanometers in the luminescence spectrum as 10 ppm uranine solutions are shifted from acidic to alkaline pH values.

The conclusion to be drawn from these experiments is that to be certain that the dye will produce a visible and a fluorescent mark, it should not be added directly to the waste holding tank, but should be dispensed separately at the dump site.

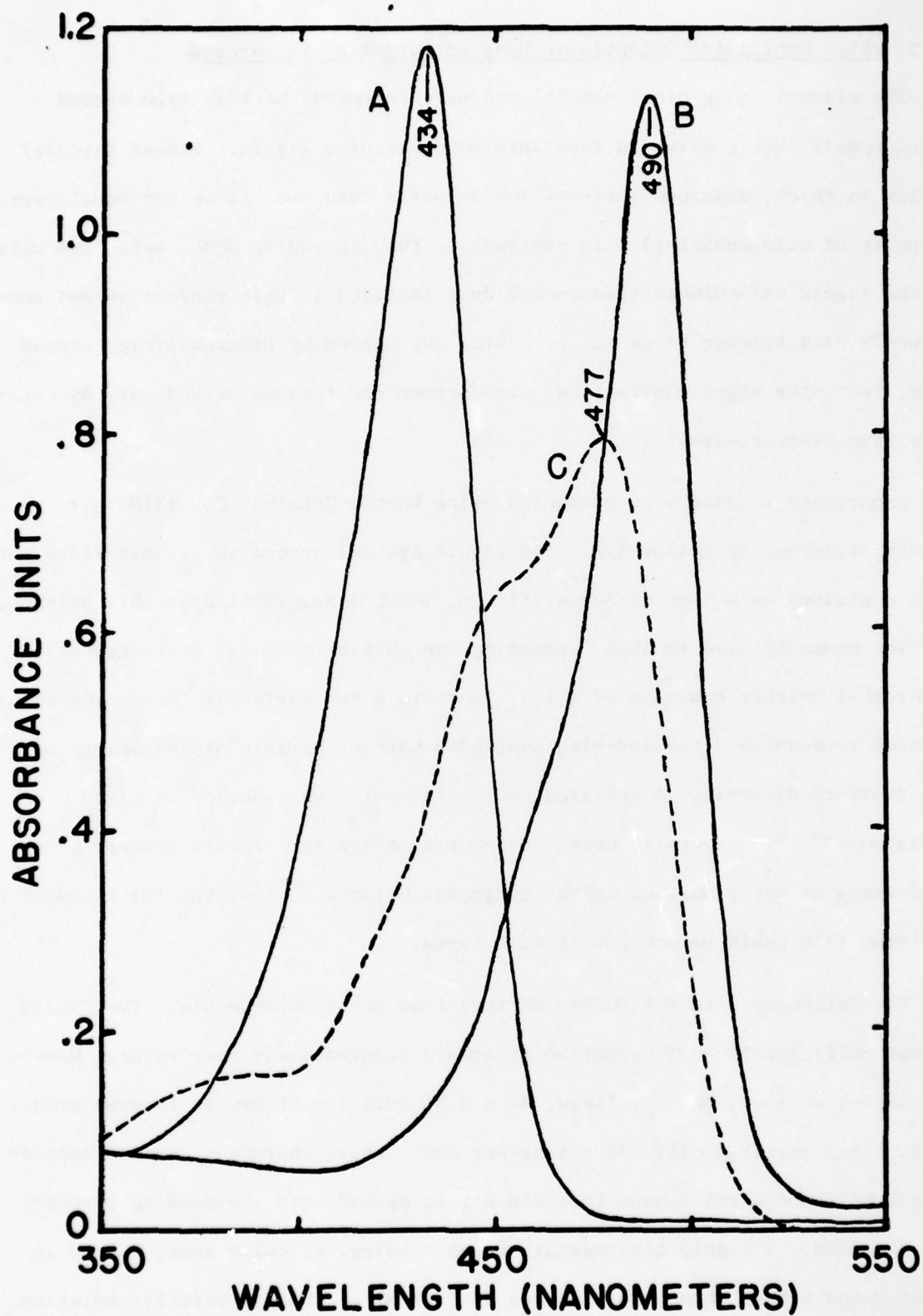

FIGURE 5. Absorbance Spectra for Uranine in Distilled Water, Acid Solution, and in Basic Solution

III.5 Films Containing Oil-Soluble Dyes as Potential Seamarkers

The slick-forming oleyl alcohol and pure compounds of this type spread spontaneously over a water surface into monomolecular layers. Excess material remains in thick, unspread lenses which do not spread over their own monolayers (property of autophobicity). In contrast to this spreading mode, petroleum oils and the liquid oil-soluble fluorescent dyes included in this project spread non-uniformly with thicker films in the center surrounded by progressively thinner films, the outer edges manifesting iridescence and regions marked only by capillary wave damping effects.

Laboratory studies were conducted using Morton Chemical Co. 131SC oil-soluble, fluorescent yellow dye. The liquid dye was spread in various forms onto water contained in a Central Scientific Co. (CENCO) No. 70551 Hydrophil Balance, a device commonly used to study spreading and surface chemical characteristics. A hydrophil balance consists of a tray to contain the surface-film covered water on which is mounted a torsion-wire-suspended barrier capable of measuring the film pressure directly. A detailed description of such a device is given by Gaines¹¹. Carefully measured amounts of dye were spread uniformly over known areas of water surface in the hydrophil balance so that the thickness of the resulting film could be accurately calculated.

The following information was derived from these experiments. The liquid dye was sufficiently surface-active to spread spontaneously over water. However, its surface activity was not large, as a 0.3% solution of dye in reagent grade, white, light paraffin oil* did not spread onto water, whereas a similar concentration of 1-dodecanol causes paraffin oil to spread with a spreading pressure of 8 dynes/cm. A highly fluorescent, non-spreading, circular lens, 2.0 cm in diameter and 0.8 mm thick was produced by 0.25 ml of the dye-paraffin solution.

* Fisher Scientific Co., No. 0-119

This behavior suggests that small-drop dispensing of this solution could produce a fluorescent polka-dot effect on a water surface.

Spreading of the liquid formulation described above was achieved by adding 0.4% 1-dodecanol to the dye-paraffin oil solution. The fluorescence of the liquid films on water was observed using a high-intensity, "long-wave" ultraviolet lamp. The liquid mixed film was visible because of its fluorescence down to a film thickness of 3.5 micrometers (3.5×10^{-4} cm). This value is more than three orders of magnitude greater than the monomolecular thickness of an artificial sea slick (2.4×10^{-7} cm), and the quantity of material required to completely cover a given surface area would be correspondingly greater for this particular dye mixture.

In the field test of June 5, 1975, it was observed that for a few minutes after spreading, highly colored, fluorescent areas were present in the center of the three-component seamarker composed of dye, paraffin oil and 1-dodecanol. The dodecanol, by reducing the water surface tension around the perimeter of the slick, reduced the spreading of the oil-like dye mixture, maintaining it in a relatively thick layer. Thus, the fluorescent oil-like dye did not spread until the film pressure of the surrounding dodecanol decreased due to outward spreading into clean water. This observation suggested an additional possible formulation which might produce a fluorescing surface mark that does not dissolve in water. Reference 9 contains an extensive discussion of the phenomenon of oil spreading control using surrounding monomolecular films. Laboratory experimentation showed that an equivolume solution of a liquid, oil-soluble dye and oleyl alcohol spreads rapidly in all directions when placed on a clean water surface. Interference colors and colored patches of the dye are evident. Subsequently, within a few seconds, the oleyl alcohol, a more surface-active substance,

preferentially adsorbs into a monomolecular layer and drives the liquid, oil-soluble dye into an irregular array of fluorescent lenses. This formulation was also studied in the field on August 19, 1975. However, the results of the laboratory studies of all formulations containing oil-soluble dyes indicated that marking an area of suitable size on the sea surface with a dye dissolved in oil would require an exorbitant amount of liquid in the seamarker package. The field test of June 5, 1975, described later in this report, supported that conclusion.

IV. PROTOTYPE DISPENSING DEVICES

Three different prototype dispensing devices were fabricated for releasing material to mark the sea in order to examine the characteristics of the marks in a series of field tests. A hand-held, throwaway canister that dispenses both a dye and a slick-forming chemical was conceived for use by individuals; a device for dispensing a larger volume of slick-forming material or a water solution of dye was conceived for making multiple, single point dumps from aboard an ocean dumping barge; and a device which dispenses the slick-forming material at a constant rate behind a moving vessel in order to produce a long, narrow mark on the sea surface was developed.

IV.1 Hand-held Dye/Slick Marker Prototype Dispensing Device

The floating dye-slick sea marker shown in Figure 6 was conceived to mark small objects such as individuals in the water or disabled vessels. The seamarker dispenser has a total weight of approximately 410 grams (just under 1 pound) and is 5-3/4 inches high with a diameter of 3 inches. The dispenser is constructed with two compartments of equal size, one containing 100 grams of the dye and the other 150 grams of the slick-forming chemical. A tape closure is pulled away from the top and the bottom, and the canister is thrown into the

PROTOTYPE DYE / SLICK MARKER

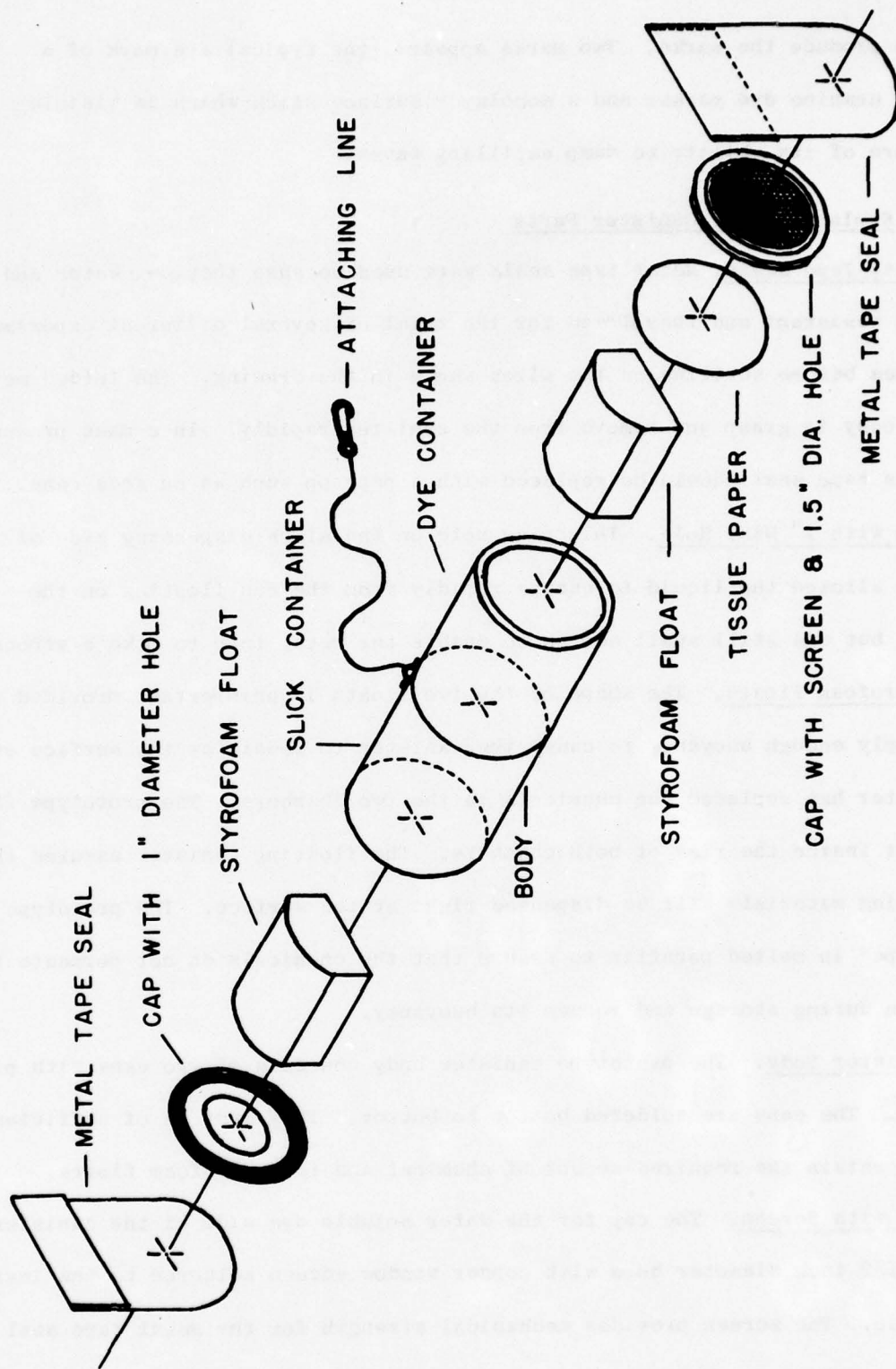

FIGURE 6. Prototype Hand-held Dye/Slick Marker

water to produce the marks. Two marks appear: the typical dye mark of a standard uranine dye marker and a monolayer surface slick which is visible by virtue of its ability to damp capillary waves.

IV.1.1 Explanation of Canister Parts

Metal Tape Seals. Metal tape seals were used because they were water and chemical resistant and they allowed for the trial of several different experimental hole sizes before settling on the sizes shown in the drawing. The folded metal tape is easy to grasp and remove from the canister rapidly. In a mass produced item this tape seal should be replaced with a pop-top such as on soda cans.

Cap with 1" Dia. Hole. This size hole on the slick dispensing side of the canister allowed the liquid to escape rapidly from the can floating on the surface, but was still small enough to enable the metal tape to make a strong seal.

Styrofoam Floats. The shape of the two floats is unimportant provided that they supply enough buoyancy to cause the canister to remain at the surface even after water has replaced the chemicals in the two chambers. The prototype floats press-fit inside the rims of both chambers. The floating canister assures that the marking materials will be dispensed right at the surface. The prototype floats were dipped in melted paraffin to assure that the chemicals do not permeate the styrofoam during storage and reduce its buoyancy.

Canister Body. The prototype canister body consists of two cans with press top lids. The cans are soldered bottom to bottom. They must be of sufficient size to contain the required amount of chemical and the styrofoam floats.

Cap with Screen. The cap for the water soluble dye side of the canister has a 1-1/2 inch diameter hole with copper window screen soldered to the inside of the cap. The screen provides mechanical strength for the metal tape seal that covers the cap. Water can easily penetrate the screen and dissolve the dye.

Tissue Paper. On the dye side of the canister a piece of porous tissue paper (such as Kleenex) which disintegrates upon contact with water is laid over the opening before the screened lid is pressed into place. This tissue prevents the finely powdered dye from spilling out of the canister before the canister hits the water.

IV.1.2 Directions For Use of the Dye/Slick Marker

The container should be held over the railing with the liquid end up. The metal tape seals are then removed from each end, and the marker is dropped overboard gently to avoid slinging out the liquid. Since the bottom section contains powdered dye, care should be taken to avoid making a mess. Note that after the tape seal is removed, the dye powder is sealed into the bottom of the container by tissue paper which will disintegrate in the water. But if the tissue is torn, some powdered dye can escape. The marker should be held over the railing when removing the tape seals. The marker contains blocks of styrofoam which make it float at the water surface even when full of water, and as the wind and waves move the canister around, the chemical is dispensed over a period of about 10 minutes as water displaces the less dense oleyl alcohol from the can and dissolves the dye from the other end.

IV.2 Multiple, Single-point Dispensing Device Prototype

Mathematical analysis of the results of field experiments reported later in this report (Fig. 14) indicated that many liters of oleyl alcohol would be required to produce a marker slick with a lifetime of more than 12 hours. Therefore, a device has been constructed to dispense large volumes of chemicals. The prototype device dispenses 10 liters of liquid at a time from a standard 30 gallon steel chemical drum and is shown in Figure 7. Approximately 12 dumps of 10 liters each can be made before a new 30 gallon drum needs to be strapped

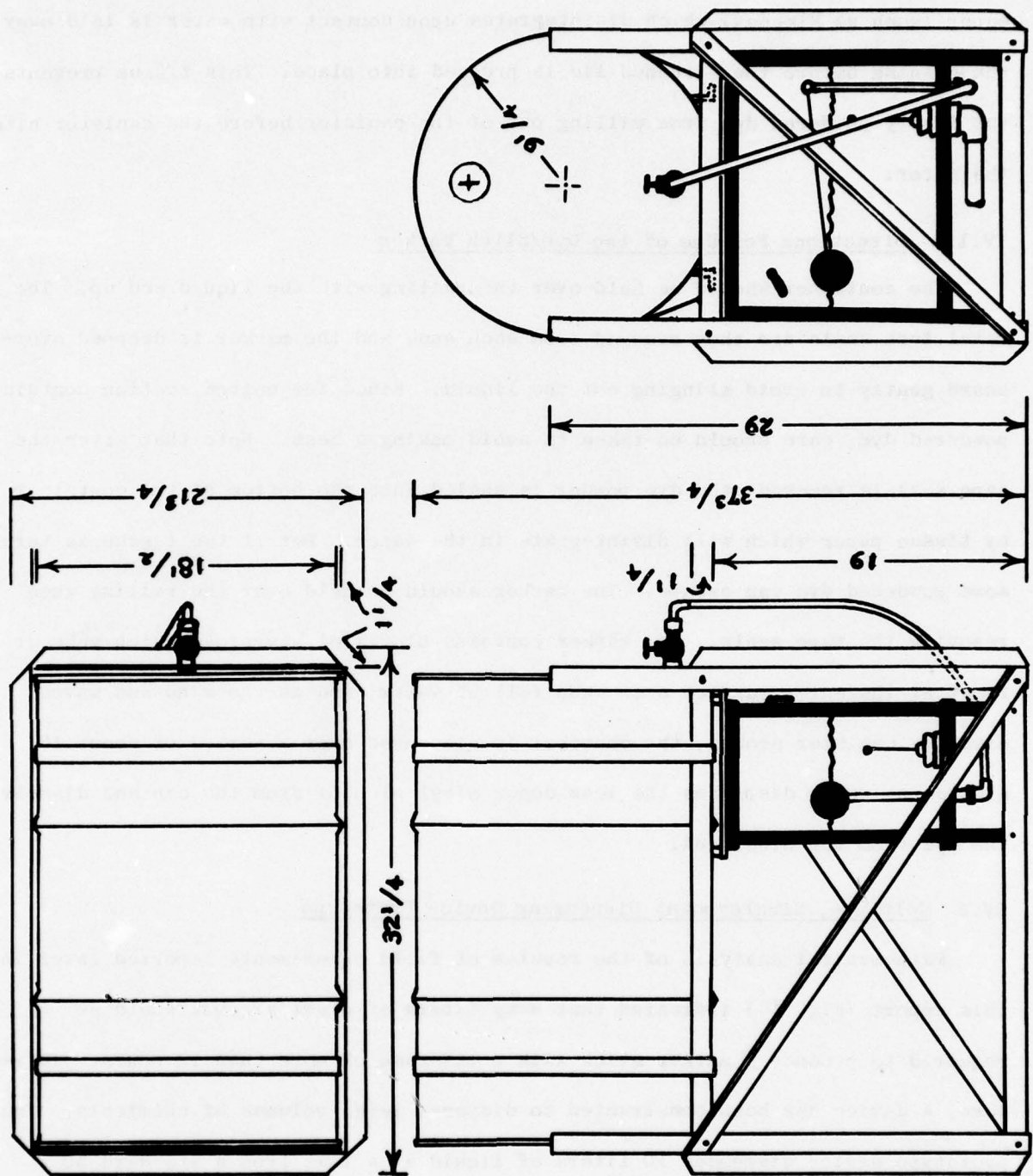

FIGURE 7. Prototype Multiple, Single-Point Dispensing Device

into the rack.

After considering several types of containers and valves it was decided that a device utilizing the standard 30- or 55-gallon size steel drum in which chemicals are normally shipped, combined with a modified standard float valve in a reservoir, would be the most practical design.

The prototype device is presently manually operated, but the addition of an actuating switch and a solenoid compatible with the ship's power to operate the lever once for each dump would make it completely automatic. The float valve arrangement was chosen because an electric gate valve would require a constant high current to hold it open during the draining of the reservoir, using a large amount of power. To conserve power used by the electric gate valve, the system would need to be pressurized, creating a potential safety hazard. Also, large solenoid-driven gate valves are expensive. A float valve, on the other hand, needs power only for a fraction of a second when opened by a solenoid, and the system need not be pressurized since the valve will not close until the reservoir drains. The volume dispensed is controlled by the size of the reservoir and the float level, not by the length of time that power is delivered to the valve. In the prototype device, the valve system is contained in a reservoir made from 5/16 inch thick acrylic plastic that is 7-3/8 inches wide, 15-7/8 inches long, and 13-3/8 inches deep.

Three modifications shown in Figure 8 were made to a standard float valve in order to dispense chemicals at sea. The float rod passes through a 1/2-inch slot to prevent the motion of the ship from causing the top of the valve to twist. The bowl filler tube is not directed into the overflow tube as in usual installations but instead is allowed to discharge into the reservoir.

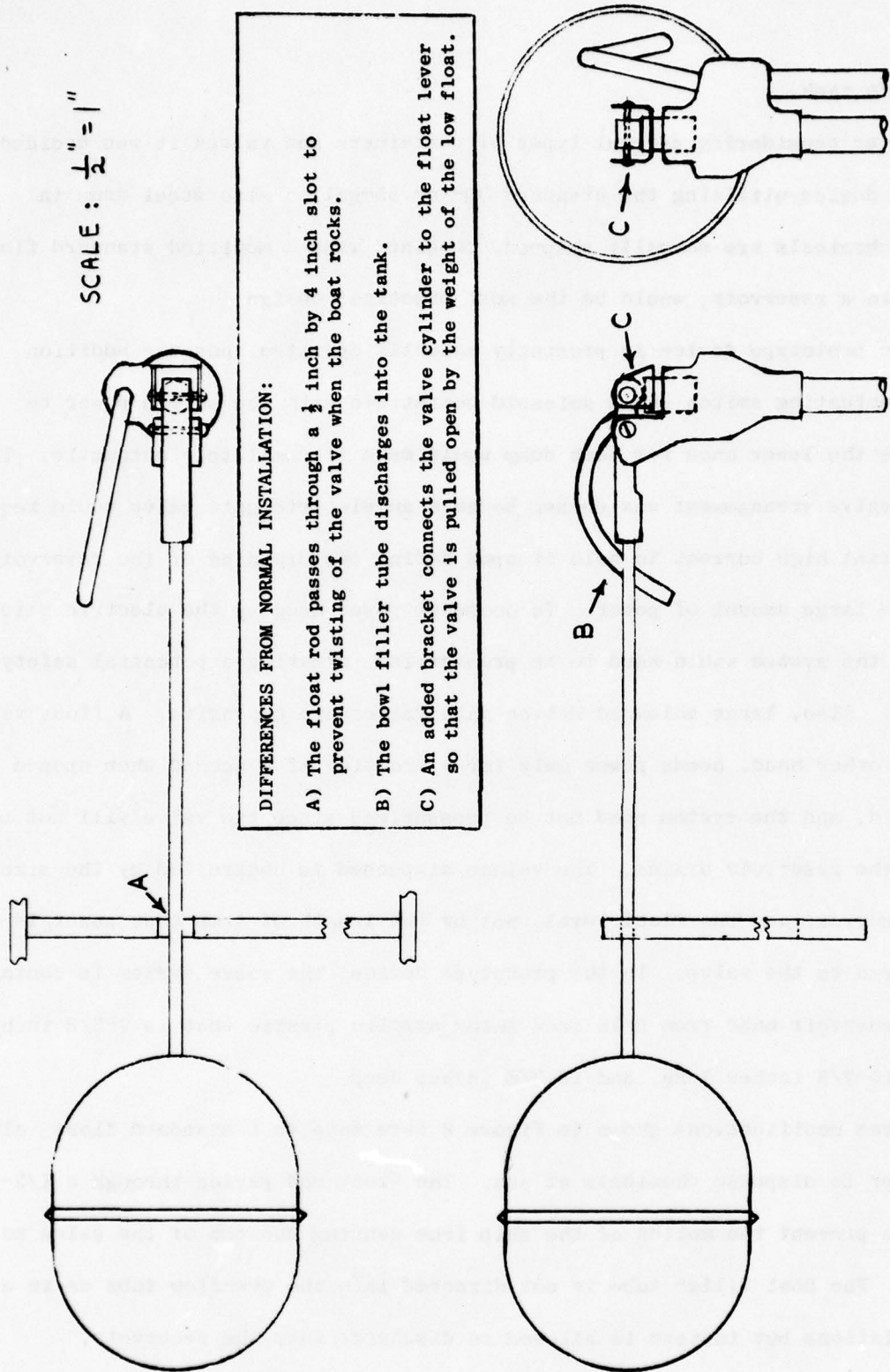

FIGURE 8. Float Valve Modifications for Multiple Dumping Device

The third modification is the addition of a small bracket to couple the float lever to the valve cylinder. This assures that the valve will open to refill the reservoir after it has emptied. Since the chemical is fed by gravity to the reservoir, there might not be enough pressure to open the valve. The addition of the coupling bracket assures that the valve will be pulled open by the weight of the lowered float in the emptied reservoir.

IV.3 Prototype Chemical Dispenser with Constant Flow Rate

After a discussion of the objectives of the May, 1976, California field experiments with other groups involved, it was decided that in addition to releasing several small dye/slick markers, several 2-mile-long slicks would be created from the surface craft to simulate a vessel discharging oil. This would allow a test of the ability of the radar to detect a vessel spilling oil and at the same time give information about the amount of oleyl alcohol required to produce a mark visible to the radar.

To produce long narrow marks for which the amount of chemical used was accurately known, it was necessary to construct a chemical dispenser with a constant flow rate. In the past, artificial sea slicks have been generated from small craft by personnel from the Naval Research Laboratory, and the design of the apparatus used to dispense the slick-forming material has evolved slowly to the form shown in Figure 9 which was assembled for the May, 1976, California experiments.

The apparatus in Figure 9 is independent of ship's power and can be used from aboard small open boats if necessary. The 30-liter steel can in which the chemical can be shipped has threaded fittings like a standard 55 gallon steel drum. Field preparation consists of unpacking the 30-liter can and attaching the chemical exit pipe (D in Fig. 9) and the small nitrogen cylinder with

CONSTANT FLOW RATE CHEMICAL DISPENSER

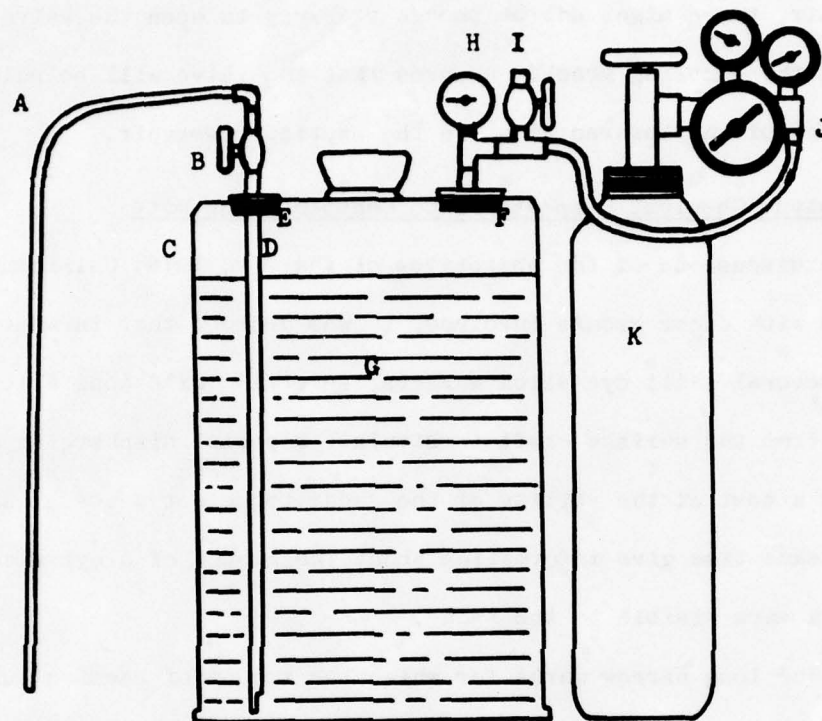

- | | |
|---------------------------------|---|
| A. 1/4 in. o.d. Tygon tubing | G. Chemical to be dispensed |
| B. On-Off valve | H. 0-30 ppsi pressure gauge |
| C. 30-liter steel can | I. Pressure relief valve |
| D. 1/4 in. i.d. pipe | J. Pressure reduction gauge |
| E. 1 in. diameter threaded plug | K. 4 in. x 17 in. nitrogen gas cylinder |
| F. 2-1/4 in. dia. threaded plug | |

FIGURE 9. Prototype Chemical Dispenser with Constant Flow Rate

pressure regulating fittings. The flow rate of the chemical is controlled by the pressure of the gas above the liquid in the can. The can is calibrated in the laboratory prior to an exercise by preparing a table of chemical flow rates vs. the pressure in the can. To determine the volume of material dispensed very accurately, however, the depth of liquid in the can is measured before and after dispensing. The apparatus maintains a constant flow rate, but changes in the viscosity of the liquid due to a difference in the laboratory and field temperature can cause changes in the total amount of material actually dispensed. Field operation of the apparatus consists of simply setting the pressure regulator to deliver the desired pressure, and then opening the on-off valve. In practice the cans have been operated at up to 10 lb/in² of pressure without rupturing. However, the lowest pressure possible has always been used, since the cans were not designed to be pressurized. To achieve higher flow rates at the same pressure, a larger diameter chemical exit pipe can be used. A much sturdier chemical container designed for pressurization has been acquired since the May experiments and is recommended for future pressurized dispensing apparatus. The new 15 gallon capacity drum is fabricated from stainless steel with all seams welded and is designed for pressures up to 80 lbs/in²*. Such drums are used for shipping volatile chemicals and for dispensing pressurized beverages such as beer. The ability to go to higher pressures gives a much wider choice of flow rates. The new type chemical container is much safer to use than the earlier type.

*Manufactured by Firestone Steel Products of Canada, London, Ontario.
Acquired from McMaster-Carr Supply Co., Elmhurst, Illinois.

V. FIELD STUDIES OF SELECTED DYES AND SLICK-FORMING CHEMICALS

An airborne laser surveillance field test to detect dye dissolved in the water which was tentatively scheduled for June-July, 1975 off the coast of California and a New York ocean dumping test tentatively scheduled for April, 1976, did not take place. However, an alternative series of field tests provided most of the desired opportunities for testing of the mark-making chemicals and dispensers. Five field studies were carried out between May, 1975, and October, 1976, at the following times and places:

Field Test No. 1 : June 5, 1975, in the Chesapeake Bay east of Chesapeake Beach, Maryland

Field Test No. 2 : August 19, 1975, in the Chesapeake Bay east of Chesapeake Beach, Maryland

Field Test No. 3 : September 25, 1975, in the Atlantic Ocean northeast of the entrance to the Chesapeake Bay

Field Test No. 4 : May 19, 1976, in the Pacific Ocean west of Santa Barbara, California

Field Test No. 5 : May 21, 1976, in the Pacific Ocean west of Morro Bay, California

V.1 Field Test No. 1: June 5, 1975

On June 5, 1975, a field study was conducted in the Chesapeake Bay southeast of the Chesapeake Bay Annex of the Naval Research Laboratory in the vicinity of buoy 6-B. This exercise was a preliminary study to qualify sea-marker systems. The markers were released from a Navy LCPL motor launch and photographed with 35 mm still and 16 mm motion picture cameras. Aerial photography was performed with a hand-held 35 mm camera from a H-1 helicopter. The

objectives of this field exercise were a) to evaluate the performance of the hand-held dye/slick dispenser shown in Figure 6, b) to study the spreading characteristics of oleyl alcohol, the first-choice slick-forming chemical, and c) to determine the feasibility of using oil-soluble, fluorescent dye films as seamarkers.

Data on environmental conditions were observed and recorded since seamarker visibility and persistence (especially sea surface films) are strongly influenced by air-sea dynamics, meteorological conditions and viewing angles. During this exercise winds were light but quite steady at 5-6 knots from S to SE. Air and water temperatures were 27.2 and 23.0°C respectively. Bay surface conditions were 1/2 foot waves (estimated) and generally rippled, thus providing sufficient definition for the detection of seamarker slicks. The sky was essentially cloudless, but due to low level haze and an unfortunate choice of photographic angles, most of the aerial photography was not of sufficient clarity for analytical purposes. However, a few of the photographs could be used to compare slick sizes predicted by equations to sizes estimated in the field.

The hand-held slick/dye dispenser was tested in two modes: free-floating and tethered to a sea-anchor-type float to simulate an object in the water. The sea-anchor was constructed of a 2-foot square piece of 1/4 inch plywood weighted at one corner and with a styrofoam float at the opposite corner. The float was marked with a small flag on a 2-ft, 1/4 in. diameter pole. Except for a few inches of one corner, the entire sea anchor was below water. A rigid wire bracket, normal to the plane of the sea anchor was used to attach the marker line.

Both seamarker canisters performed satisfactorily, dispensing the fluorescent uranine dye into the water column and creating a visible artificial slick

from the oleyl alcohol. One hour and 22 minutes after the initial activation and emplacement of the canisters in the water, both slick and fluorescent dye marks were still readily visible. Under the relatively calm sea conditions, the dye mark appeared to remain near the water surface in an elongated stripe. The artificial slick, which moves at approximately 5% of the wind velocity, had proceeded to the west of the sea anchor while the fluorescent dye was aligned to the east of the dispenser. This was caused by a slight wind from the east. The dye remained essentially at the point it was dropped, the free-floating sea-anchor which protruded slightly above the water drifted slightly to the west, and the slick which lies right on the water surface was moved farther to the west by the wind.

Both slick and dye marker were quite visible for greater than 82 minutes under these conditions. It was estimated that the slick, which had been formed by 150 ml of oleyl alcohol, occupied a surface area of 3,500 square meters. The observed lifetime agrees reasonably well with the lifetime predicted by the graph in Figure 14 which is based on a mathematical expression developed from the data of the September 25th experiment and the equations developed by Fay¹³. Mathematical expressions for monolayer surface film behavior at sea are given later in this report.

Three oil-soluble dye mixtures were tried as sea markers during the June 5 Chesapeake Bay studies:

- a) Fluorescent oil-soluble dye 131-sc, 50 ml
- b) Fluorescent oil-soluble dye 131, 50 ml
- c) Fluorescent oil-soluble dye 131-sc, 10 ml mixed with white, light paraffin oil, 99 ml and 1-dodecanol, 0.4 ml

These liquids produced marks which contained fluorescent zones and oil-like

iridescent zones for a few minutes. However, they quickly thinned into films whose thickness was less than that of the frequency of visible light, so that their appearance was that of a petroleum sheen; an oil-like multi-layer which damps capillary waves strongly. These three candidate seamarkers spread to a circular pattern, 20 m in diameter, in about 15 minutes. These marks were quite visible and photogenic from an altitude of 300 feet, but disappeared in about 25 minutes.

The rapid dissipation of the oil soluble fluorescent dye formulations suggests that this approach to seaming is not productive. Once a film has spread to a thickness less than 300 nm it is probably not sensible through light interference effects or fluorescence, although its presence is obvious to certain electromagnetic wavelengths as a reflectance anomaly on the water surface.

V.2 Field Test No. 2: August 19, 1975

A second trip was made to the Chesapeake Bay on August 19, 1975 to compare marks made by oleyl alcohol, sorbitan monooleate, and a mixture of oleyl alcohol (50 percent by volume) with the oil-soluble fluorescent dye, Fluorescent Yellow 131, which was formulated as the result of observations made in the previous field test of June 5. The area of the marks produced by 100 cc of the different materials was studied as a function of the time elapsed since their release in order to get information about persistence and sizes of the marks. The results of the test are shown in Table 2.

Table 2

Marks Made by 100 ml of Candidate Sea Marking
Materials on the Chesapeake Bay, August 19, 1975

Seamarker Area (meters ²)			
Time (minutes)	Oleyl Alcohol (84.9 grams)	Sorbitan Monooleate (99.8 grams)	Oleyl Alcohol plus 50% Oil-soluble dye (88.5 grams)
19	890	890	890
30	286x17 = 4862	229x17 = 3893	229x21 = 4809
60	---	no visible slick	----
85	142x23 = 3266	---	98x15 = 1470

During the period of these observations, the wind decreased from 12-15 knots to 7-10 knots. Waves were 1-2 feet high, with a few whitecaps evident at the beginning of the experiment. Water temperature was 26.4°C, while air temperature increased from 26°C to 28°C during the period. The bay surface water was entirely rippled; no natural or pollutant slicks were in the operating area.

The dimensions listed in Table 2 were estimated as accurately as possible but are subject to some error. However, from this experiment it is certain that the pure oleyl alcohol produces a mark that is larger and more durable than either of the other two materials compared to it in the test.

V.3 Field Test No. 3: September 25, 1975

On September 25, 1975, we participated in a joint field exercise with Dr. James Hollinger's group from NRL and the U.S. Coast Guard. Several photographs from this experiment were suitable for determining slick sizes as a function of time. Observations of the marker slicks in the Atlantic Ocean

were continued for a sufficient period of time to observe the dissipation of two slicks and provided enough data to permit estimates of the lifetimes of future slicks formed from a given amount of material. Aerial observations and photographs of two marker slicks were made from a NASA C-118 aircraft. The aircraft was flying repeatedly over a 500-gallon fuel oil dump in the Atlantic Ocean northeast of Norfolk, Va. made by the Coast Guard to test the airborne passive microwave oil sensing device developed by Dr. James Hollinger of NRL. From the photographs of the oleyl alcohol marker slicks and a knowledge of the time elapsed since the dispensers were placed in the water, it has been possible to develop a method of approximating the expected shape, size and lifetime of future small artificial slicks to be used as seamarkers. On the basis of this information a better judgement of the amount of material and type of dispensing apparatus necessary to achieve a desired result can be made.

Two packages containing oleyl alcohol were tossed overboard from the Coast Guard vessel Cherokee at 11:20 and 11:28 am as it proceeded toward the site for the oil dump. The first package was 3 liters of oleyl alcohol in a 1-gallon can containing a styrofoam float inside to hold the can at the surface. The lid had a 1-inch diameter hole through which the oleyl alcohol was displaced by the denser seawater as it flowed into the can. The second container, thrown overboard from the tug at 11:28, was a prototype dye/slick marker containing 100 grams of powdered uranine dye in one end and 150 grams of oleyl alcohol in the other end. This package also contained styrofoam floats inside to hold it at the water surface as shown in Figure 6.

After the markers were dispensed, the boat proceeded to the oil dump site. The aircraft flew repeated passes at 500 feet directly over the oil dump. During the passes over the oil, photographs of the slicks formed by the two oleyl alcohol

markers were made through the port side window of the aircraft. The dye served to distinguish one slick from the other and also to mark the spot on the sea covered by the smaller amount (150 g) of oleyl alcohol. This allowed the accurate determination, for the first time, of the lifetime of a mark made from a known amount of oleyl alcohol on the open sea, since flights continued for a sufficient time to observe the reappearance of capillary waves over the dyed area at 12:46. On the open sea with 10-13 knot wind conditions, 150 grams of oleyl alcohol persisted for an hour and 18 minutes \pm about 10 minutes. The size of the slick produced can be approximated from photographs showing the Cherokee and the slick together (Fig. 10).

Although the 3-liter mark was still visible when the aircraft left the area at 1252, it was not seen when the aircraft returned at 1508 for the afternoon operations. If the 3-liter mark dissipated during the absence of the aircraft, it had a lifetime of between 92 and 228 minutes. Since the fuel oil slick from the morning operations was seen again in the afternoon, but the oleyl alcohol slick was not, the 3-liter slick must have dissipated during the time the aircraft was away from the operating area.

V.3.1 Determination of Slick Lengths from Photographs

If a photograph of a slick also shows an object of known length on the water surface such as the Cherokee in Figure 10, and the horizon is also shown, the left to right horizontal length of the slick can be estimated with reasonable accuracy. A vessel at an infinite distance from the observer can be represented by a point on the horizon at the center of the picture. From this point, lines can be drawn to project the length of the vessel to horizontal lines through the slicks on the water surface in the picture as

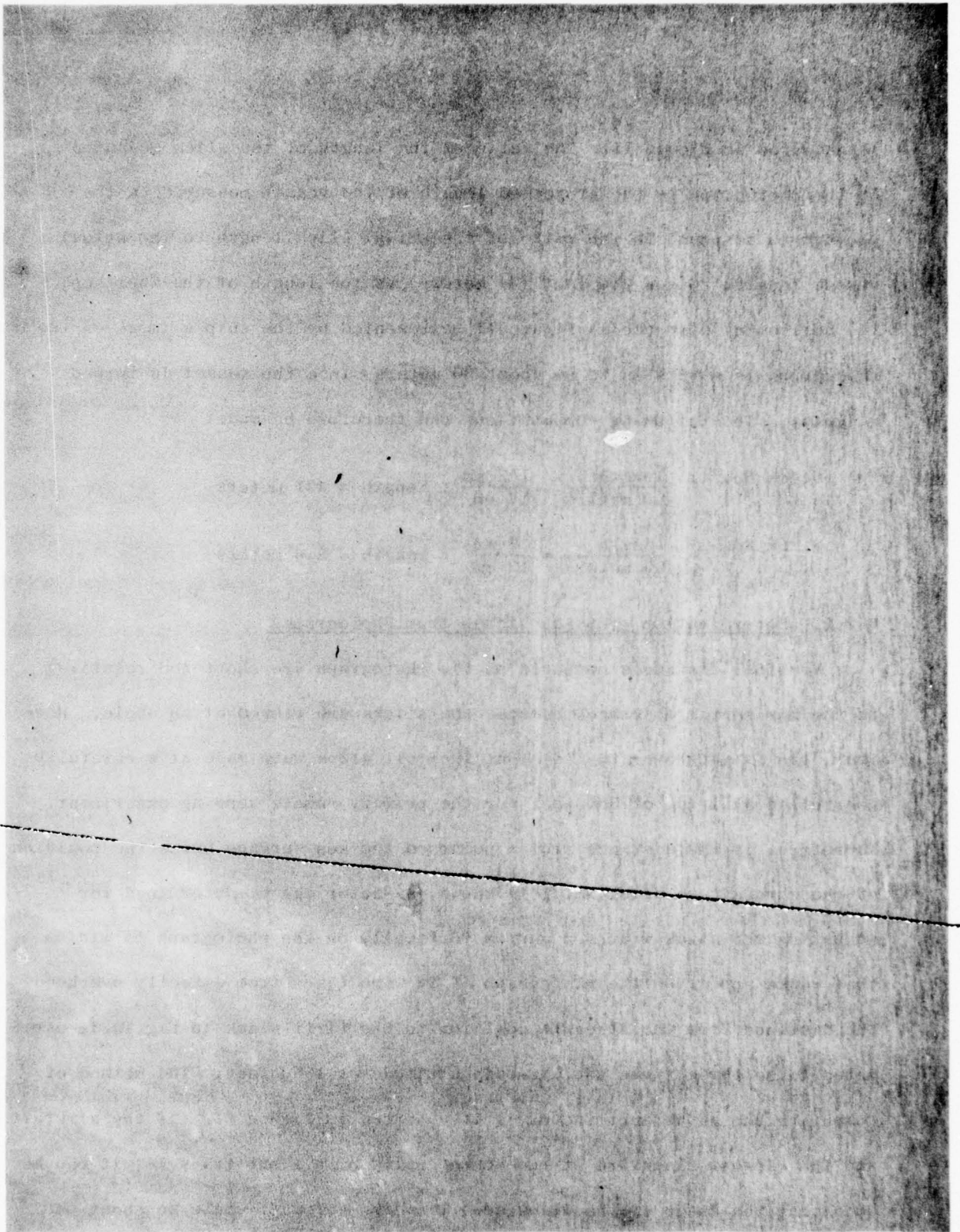

FIGURE 10. Photograph of 150 gram and 3 liter Oleyl Alcohol Slicks from 500 ft.

illustrated in Figure 11. The ratio of the length of the slick measured on the photograph to the projected length of the vessel measured on the photograph is equal to the ratio of the actual slick length to the actual vessel length. Given 210 feet (64 meters) as the length of the Cherokee, the horizontal distance in Figure 11 represented by the ship's image on the photograph is estimated to be about 50 meters since the vessel is turned slightly. The following computations can therefore be made:

$$\text{Slick No. 1: } \frac{\text{length}}{50 \text{ meters}} = \frac{143 \text{ mm}}{17 \text{ mm}} ; \text{ length} = 421 \text{ meters}$$

$$\text{Slick No. 2: } \frac{\text{length}}{50 \text{ meters}} = \frac{59 \text{ mm}}{12 \text{ mm}} ; \text{ length} = 246 \text{ meters}$$

V.3.2. Determination of Slick Widths from Photographs

Vertical distances measured on the photograph are shortened relative to the horizontal distances because the slicks are viewed at an angle. However, the flights over the adjacent fuel oil slick were made at a carefully controlled altitude of 500 feet for the primary remote sensing experiment. Therefore, if the distance from a point on the sea surface below the position of the aircraft to slick No. 1 is known, a factor can be determined for adjusting the slick widths measured vertically on the photograph to widths that would appear on the photograph if it were taken from directly overhead. The distance from the aircraft position to the first slick in Fig.10 is estimated to be three times the aircraft altitude or 1500 feet. The method of computing the adjustment factor is illustrated in Figure 12. If the aircraft and the closest slick are at the acute angles of a right triangle, it can be seen that the image of the slick seen from the aircraft would be about one third the width that would be observed if the aircraft were overhead. Therefore, the width of the marker slick measured on the vertical centerline of the

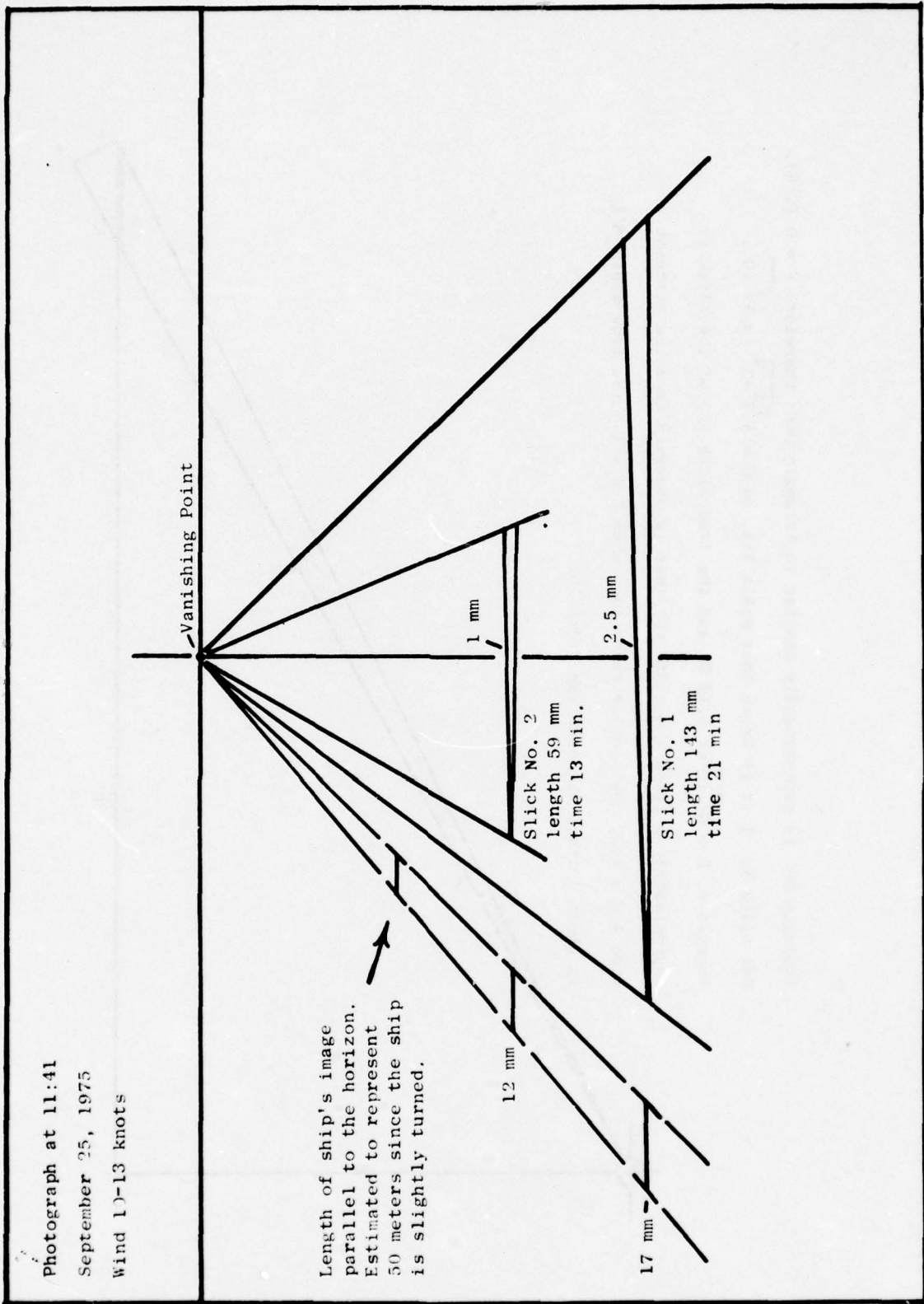

FIGURE 11. Method of Determining Slick Lengths from Photographs

Triangle ABC is geometrically similar to triangle DEF; therefore $F = D (C/A)$.

For Slick No. 1 it is known that $B:A = 3:1$, so $C = A\sqrt{1+3^2} = A\sqrt{10}$.

Therefore, $F = D\sqrt{10}$ or $3.16 D$, and the true width (F) of the slick is

approximately 3 times the width (D) that is observed from the aircraft

when $A:B = 1:3$. By similar reasoning, when $A:B = 1:4$ the true width (F)

is about 4 times the observed width (D).

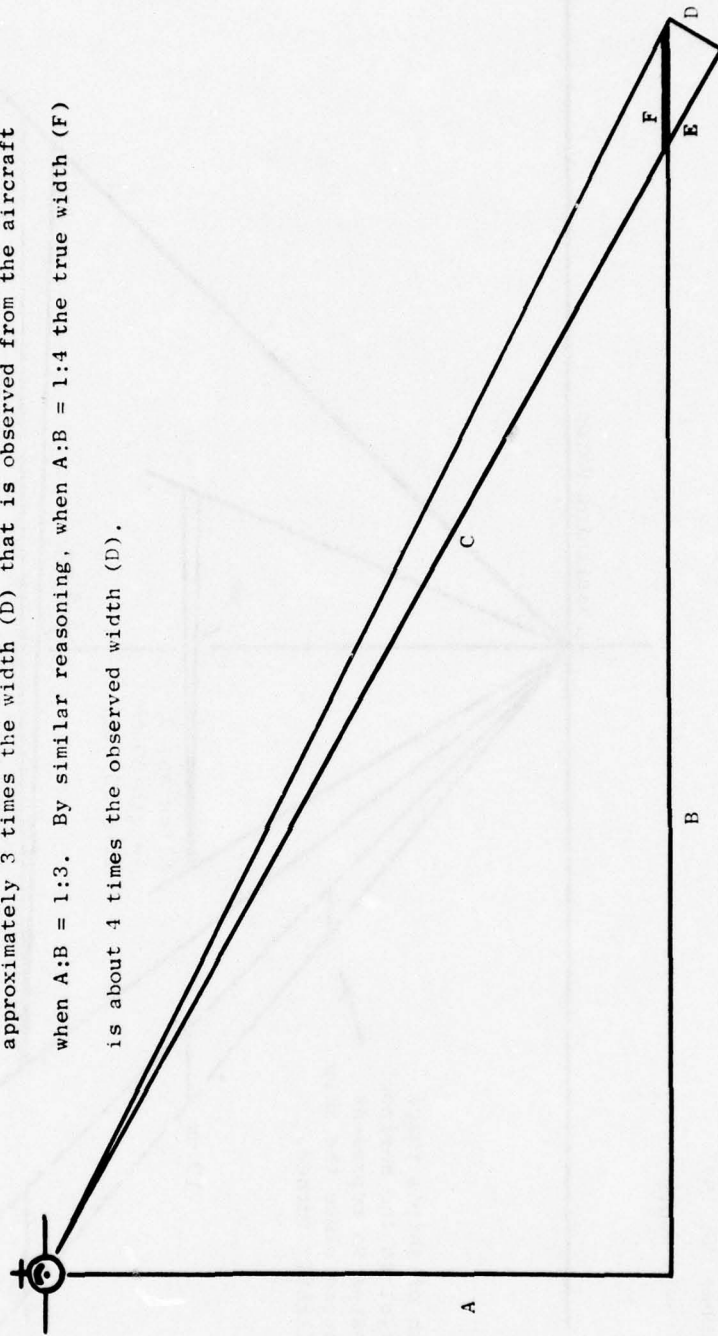

FIGURE 12. Method of Determining Slick Widths from Photographs

photograph can be multiplied by three to compare to distances measured horizontally on the same slick. The distance between the two marker slicks can be estimated using the factor from the first slick and is found to be approximately 500 feet. Following the same method, a factor of four is determined for the width of the second marker slick relative to its horizontal length. Obviously, the distance estimated between the aircraft location and the slicks controls the factor obtained by this method. However, the estimates given here are believed to be conservative. Estimates of larger distances would give proportionally larger factors leading to wider estimates for the slicks.

$$\text{For Slick No. 1: } \frac{\text{width at half length}}{50 \text{ meters}} = \frac{3 \times 2.5 \text{ mm}}{17 \text{ mm}} ;$$

$$\text{width at half length} = 22 \text{ meters.}$$

$$\text{For Slick No. 2: } \frac{\text{width at half length}}{50 \text{ meters}} = \frac{4 \times 1.0 \text{ mm}}{12 \text{ mm}} ;$$

$$\text{width at half length} = 17 \text{ meters.}$$

Since the area of a triangle is half the base times the height, the areas of the two slicks can be approximated:

$$\text{Area of Slick No. 1: } 22 \text{ meters} \times 421 \text{ meters} = 9262 \text{ meters}^2$$

$$\text{and Area of Slick No. 2: } 17 \text{ meters} \times 246 \text{ meters} = 4182 \text{ meters}^2 .$$

The data from this experiment contributed greatly to the understanding of monolayer slick behavior on the sea. Since relatively accurate size data could be correlated with the time elapsed since the slick-forming material was released, it was possible to develop new descriptive equations to give an approximation of shape and size of a slick under the influence of the wind. The equations are presented later in this report. Since the lifetime of a known amount of oleyl alcohol could be determined very accurately, it was also possible to determine that the rate of loss of that extremely insoluble material from a slick was 53 micrograms per square meter per minute on the open

sea. It is presently believed that the most likely cause of this loss is adsorption of the surface-active oleyl alcohol onto suspended particles in the sea water. Surface-active material is also transported into the air by bursting bubbles.

V.4 Field Test No. 4: May 19, 1976

Field tests to investigate the detectability by radar of slicks formed by oleyl alcohol on the sea surface were carried out during the week of May 16, 1976, in the coastal waters of California. The joint field tests arranged by the Coast Guard included representatives from the Coast Guard, NRL, the Motorola Co., and the University of California at Santa Barbara. The tests had several objectives. The primary purpose was to test the over-water mapping capability of the synthetic aperture radar being developed for the Coast Guard and the Army by the Government Electronics Division of the Motorola Company. The artificial-slick-forming chemical used in the NRL-developed dye/slick markers was used to simulate an oil spill to test the radar. Simultaneously, the detectability of the slick formed by the oleyl alcohol could be documented. Representatives from the University of California at Santa Barbara took aerial photographs from a light aircraft during the exercises. Representatives from the Naval Research Laboratory dispensed the oleyl alcohol slicks and dye slick markers on May 19, 1976, from aboard the Point Judith operated by the Coast Guard Group at Santa Barbara, California, and again on May 21, 1976, from aboard the Cape Hedge operated by the Coast Guard Group at Morro Bay, California.

NRL personnel left Santa Barbara, California, aboard the Coast Guard vessel Point Judith at 1200 PDT on May 19th and waited at a station near the Holly Tower oil drilling rig southwest of the Santa Barbara Airport for the aircraft coming from Pt. Mugu. The position was more than three miles from shore. A

radar reflector buoy was placed in the water at 1453. While the Point Judith moved away from the radar reflector two dye/slick canisters were released at 1457 about 100 feet apart. The dye/slick markers contained 300 grams of the slick-forming chemical oleyl alcohol and 150 grams of powdered uranine dye. The Point Judith remained stationary near the two dye/slick marks while the aircraft made passes over the area. The radar reflector was then recovered, and upon command of the radar aircraft the generation of a 2-mile-long artificial sea slick was begun at 1550 using the apparatus described in Figure 9. First a standard dye package (100 grams of uranine) was released, and then the Point Judith ran in a straight line on a course of 120° at a speed of 8 knots while the slick-making chemical oleyl alcohol was dispensed into the wake at a constant flow rate of 540 ml/min from a pressurized container. At the end of 15 minutes (1605) the flow was stopped and another dye marker was released to mark the end of the stripe. A total of 8.1 liters of oleyl alcohol was dispensed. The linear concentration of oleyl alcohol was 1.94 ml/meter. The dye spots at the beginning and end of the 2-1/4 mile long stripe that was created served to distinguish the artificial slick from any natural slicks that were in the vicinity. There were many natural slicks near shore originating from the marine life and from oil seeps in the region of Coal Oil Point. During the time when the slick was generated on May 19th the sea was choppy with swells from 270° at a height of 3 feet. The wind velocity was 18 knots from 220° . Water temperature was 15.0°C , and the visibility through the haze at the sea surface was estimated at 8 miles.

V.5 Field Test No. 5: May 21, 1976

The Coast Guard vessel Cape Hedge left Morro Bay, California at 1035, May 21st for a station 3 miles directly west of Morro Rock. Because of unusually

calm weather the Cape Hedge moved farther offshore searching for an area free of natural slicks in which to operate. A single dye/slick marker was released into the first rippled region encountered at 1134. The Cape Hedge eventually reached an area of slightly more rippled water about 5-1/2 miles west of Morro Rock which was judged adequate to begin the 2-mile-long stripe. The first marker dye was released and the stripe was begun at 1144. The Cape Hedge maintained a steady 8 knots on course 275° for 15 minutes, and the stripe was ended with another dye mark at 1159. A total of 4.9 liters of oleyl alcohol was dispensed at a rate of 327 ml/min, to make the long stripe. The distance actually travelled by the boat was again 2-1/4 miles. The linear concentration of oleyl alcohol was 1.18 ml/meter of slick length. While the long stripe was being generated the sea was smooth but had about 50% coverage by capillary ripples. Swells were 1-foot high from the west, and the wind was from the southwest at 4 knots. The sky was heavily overcast with surface visibility through the haze of about 5 miles. The water temperature was 11.9°C .

On both occasions when the 2-mile-long stripes were generated the radar was able to unambiguously detect the marks. The University of California observers reported that they were able to visually locate both the small dye/slick markers and the long stripes for aerial photography. The ability of the radar to see the 2-mile-long stripe on the 21st of May was very encouraging because the mark was made in an area that contained very many naturally occurring slicks and because wind was unusually calm (about 4 knots). The radar senses the absence of the small capillary waves damped out by the chemical, not the chemical itself. If there are not waves to damp, no mark will be sensed. It was found that about 1 milliliter of oleyl alcohol dispensed behind a boat per meter of distance travelled was sufficient to produce a slick detectable by

radar. Even less material might be successfully used.

Since the long narrow stripes made by the oleyl alcohol were easily detected by the radar even in calm regions where many natural slicks occurred, a reassessment of the method of dispensing marking chemicals from ocean dumping barges seems warranted. A single point dump of material as suggested earlier should produce a mark that persists for a longer time (see section VII.2), but a long stripe behind the barge might be easier to detect by radar. In a region of many natural slicks a long, narrow oleyl alcohol slick would be easier to distinguish than a slick from a single point dump. Uranine dye is not detectable by radar. An automated, improved version of the pressurized dispensing device used in the May field tests (Fig. 9) could be developed for use aboard ocean dumping vessels. It would, of course, be more complicated and require more power than the device suggested for single point dumps in Figure 7.

VI. FACTORS AFFECTING THE GROWTH AND DISSIPATION OF MONOLAYER SLICKS

Monolayer slick size and durability are limited by the dispersive forces illustrated in Figure 13. Since seamarkers need only last for several hours, the slow processes of evaporation, photochemical oxidation, and biological feeding need not be considered except to account for the ultimate fate of the film-forming chemical. The surface-active material used to form the monolayer film is less dense than water and is very insoluble so that dissolving is not a major reason for loss from the film. Greater loss of material from the monolayer film will be due to air-sea dynamics including physical entrainment in the water column in rough seas, followed by irreversible adsorption on particulate material suspended in the water, and transport into the air on droplets of water ejected from the sea surface by bursting bubbles which are small enough

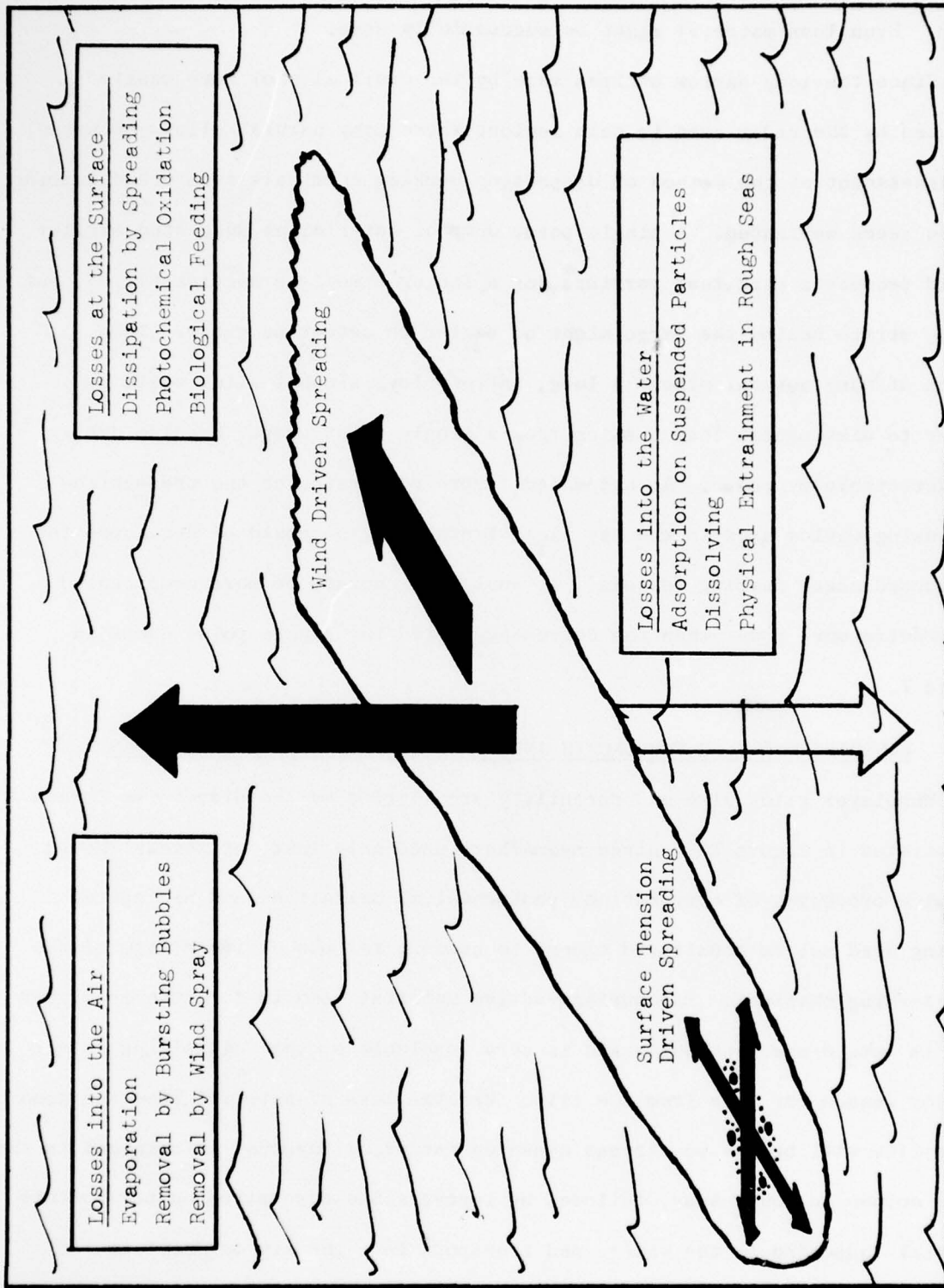

FIGURE 13. Factors Affecting the Growth and Dissipations of a Monolayer Slick

to remain airborne. Although the individual loss rates due to the above-mentioned factors have not been determined, the loss rate due to all factors combined was computed from the results obtained in the field experiment of September 25, 1975, and found to be 53 micrograms per square meter per minute on the open sea under wind conditions of 10-13 knots.

The primary reason for the disappearance of the damped capillary wave region, however, is that the molecules of the surface film spread spontaneously away from each other. An oleyl alcohol molecule contains 18 carbons in a long chain with an oxygen at one end. The molecules in the surface film are all aligned with the oxygen "head" toward the water surface the carbon "tail" pointing upward. The molecules are polar with a net negative electrical charge residing on the oxygen which causes the adsorption on the water surface. These polar molecules repel each other. Once the molecules are spread far enough apart, they no longer exert a force on each other, and the alteration of the water surface tension is ended. When that happens, capillary wave damping no longer takes place and the "slick" vanishes, although the chemical may still be present on the surface. It has been determined in the laboratory that wave damping occurs whenever there is a detectable film pressure. Below 1 dyne/cm of film pressure no damping will occur. From the force-area curve of oleyl alcohol shown in Figure 1 it can be seen that below a surface concentration of about 1 milligram per square meter no damping would be observed.

Spreading of the surface film is assisted by the wind which tends to cause slicks to take a long, narrow shape. The bulk droplets of material protrude down into the water slightly and resist being moved by the wind more than the monomolecular layer spreading from these drops. When the wind is high it contributes greatly to the spreading of the monolayer and consequently

decreases the lifetime of the film on the surface. When the wind is low, spontaneous spreading due to repulsion of the film molecules is the major spreading force. The larger the area covered by a given amount of surface film the greater the total amount of material lost per unit time. A mathematical description of the behavior of spontaneously spreading monolayer films under the influence of wind is given in the following section.

VII. MATHEMATICAL APPROXIMATION OF MONOLAYER SLICK BEHAVIOR

VII.1. Single Point Dumping

VII.1.1. Linear Spreading in a Channel: Our interest in the spreading rates of different surface-active materials began in 1968 when a series of materials were timed as they spread single molecule thick layers down a three-meter-long channel filled with water¹⁴. Going back to the original measurements, it is found that by the method of least squares the data can be fitted to a power curve

$$x = B t^A \quad (1)$$

where x is the linear distance travelled by the monolayer in centimeters, t is the time in seconds, and A and B are constants for a given material. The constants derived from the original data are shown in Table 3.

The values of A in Table 3 are very close to 0.75. It is also known that if $t = 0$, x must also be 0, so another simpler equation

$$x = C t^{3/4} \quad (2)$$

can be fitted to the data by the method of least squares giving the values of C shown in Table 1.

Now another interesting observation can be made. The constant C for a specific material seems to be linearly related to the Equilibrium Spreading Pressure (ESP) of that material. The ESP of a monolayer-forming material is

TABLE 3

SPREADING RATE EQUATION CONSTANTS FOR SEVERAL MONOLAYER FORMING CHEMICALS

Chemical	ESP++	A*	B*	C**	D***
Dodecanol	41.1	0.7604	27.78	28.49	26.57
Sorbitan Monooleate	40.8	0.7788	23.92	25.71	26.45
Oleyl Alcohol (cis-9-octadecen-1-01)	32.9	0.7934	18.03	20.50	23.27+++
Triolein	17.0	0.7874	18.20	20.23	16.86
Spreading Oil ⁺	14.9	0.7210	17.01	15.30	16.02
Cottonseed Oil	13.8	0.7168	18.79	16.75	15.57
Tricresyl phosphate	9.0	0.7669	10.79	11.41	13.64

+ Paraffin oil with 0.78% dodecanol added by weight

++ ESP = Equilibrium Spreading Pressure, a characteristic of the material

* From least squares fit of spreading data to $x = Bt^A$

** From least squares fit of spreading data to $x = Ct^{3/4}$

*** Ideal values for C computed from a least squares fit of a straight line through C vs. ESP.

+++ $23.27 t^{3/4}$ is used throughout this report to describe linear spreading of oleyl alcohol when t is in seconds.

the maximum film pressure reached by the material when the film is allowed to come to equilibrium with an excess drop of the bulk material on a water surface. The best straight line through the values of ESP and C in Table 3 can be found by the method of least squares to give an ideal value for C which we will call D.

$$D = E + F(\text{ESP}) \quad (3)$$

Fitting the best straight line in the form of equation (3) through the values of C and ESP in Table 1 gives a correlation coefficient of 0.926 and values for the constants E and F as $10.012 \text{ cm sec}^{-3/4}$ and $0.403 \text{ cm}^2 \text{ sec}^{-3/4} \text{ dynes}^{-1}$ respectively. The values of D can now be computed from equation (3) using these constants and the measured values of ESP. Equation (3) allows the prediction of the spreading behavior of a film forming substance without having to measure it in a channel. The measurement of the Equilibrium Spreading Pressure is much easier and requires only a single determination of surface tension. Therefore, equation (4) where D can be found from equation (3) is suggested to describe linear spreading of a monolayer forming substance as a function of time:

$$x = D t^{3/4} \quad (4)$$

Values of D for several surface-active chemicals are tabulated in Table 3. Equation (5) describes the behavior of the oleyl alcohol used for making marker slicks when distance is in centimeters and time is in seconds.

$$x = 23.27 t^{3/4} \quad (5)$$

For distance in meters and time in minutes equation (6) describes the behavior of oleyl alcohol.

$$x = 5.02 t^{3/4} \quad (6)$$

Work by Fay¹³ based on a more theoretical approach to the problem of the spreading of oils of all types predicts a value of 24.12 corresponding to our value of 23.27 in equation (5) to describe linear surface tension driven spreading of an oil with an equilibrium spreading pressure of 32.9. The general agreement of our experimentally derived number for oleyl alcohol with the number Fay's equation gives indicates that equations (5) and (6) are valid for spreading in a channel when there is no wind.

VII.1.2 Wind Effects Determined from Field Data: Equation (6) seems to give a satisfactory description of spreading in a channel in the laboratory, but it was necessary to go beyond the still water and closely controlled conditions of the laboratory and develop an expression for the behavior expected from a monolayer forming chemical dumped on the sea. The effect of the wind was therefore considered.

In practice, slicks dispensed from floating containers appear as long stripes because of the wind. The mostly submerged container lags behind the slick which forms at the air-sea interface. The leading edge of the slick is observed to be wider the farther it is from the container. These considerations suggest a model slick similar to a long, narrow, slowly expanding parabola much like a smoke plume with its axis parallel to the wind direction. The triangular shape lengthens primarily due to the wind force but also because of spontaneous spreading of the material. The slick widens only due to the spontaneous spreading of the monolayer.

Since the wind conditions were known when the photograph in Figure 10 was made, and since spontaneous linear spreading should obey equation (6), a more general equation can be derived to describe the behavior of a slick dispensed under windy conditions. If equation (6) describes the spreading in a channel

from one end to the other, it should also describe the widening of a slick on the open sea since the molecules to the left and right sides act like the walls of a channel. The slick is not actually spreading from a point source, but from a long stripe of concentrated material spread by the action of the wind. In the laboratory channel spreading experiments, bulk material added at one end finished in the middle of the channel. This indicated that if the material had been added in the middle of the channel, it would have spread in two opposite directions, moving in each direction at half the rate given by equation (6). In other words, the widening of an artificial slick on the open, uncontaminated sea should obey equation (6). In addition to being lengthened by the wind, the slick is also being lengthened by spreading. Although not exactly correct, it can be assumed that along the axis, the lengthening due to spontaneous spreading obeys the same law as the widening.

Since the length of the slicks in the Figure 10 photograph from the September experiment was determined from the boat length, the rate of lengthening due to the wind alone can be calculated by subtracting the length due to spontaneous spreading and dividing by the elapsed time since the slick container was released. Data for these calculations is shown in Table 4.

Now that the average rate of lengthening due to the wind alone has been determined, an equation for the length of a slick due to wind and spontaneous spreading together can be written by combining equation (6) with the expression for length due to wind:

$$Y = 5 t^{3/4} + 17 t \quad (7)$$

where Y is the length in meters and t is the time in minutes elapsed since the monolayer forming material, oleyl alcohol, was added to the surface. Equation (7) for the length of a slick applies only to oleyl alcohol spreading under the

TABLE 4

DATA FOR COMPUTATION OF SLICK LENGTHENING RATE DUE TO WIND ALONE

Slick No.	1	2	Average
Elapsed Time (min)	21	13	
Total Length (meters)	421	246	
Length Due to Spontaneous Spreading (meters)*	49	34	
Length Due to Wind Alone (meters)	372	212	
Rate of Lengthening Due to Wind Alone (meters/min)	17.7	16.3	17.0

*Computed from equation (6)

influence of 10 to 13 knot winds such as occurred at the time of the field experiment. Equation (7) can be made more general by expressing the lengthening due to the wind as a function of the wind speed. Since 10 knots is 308.7 meters/minute and 13 knots is 401.3 meters/minute, the average wind speed was 355 meters/minute. Comparing the rate of lengthening due to the wind (Table 4) to the wind speed, it is found to be 4.79% of the wind speed. Therefore $0.048 W$ can be substituted for the 17 in equation (7) when the wind speed is expressed in meters/minute. This gives the more general equation,

$$Y = 5 t^{3/4} + 0.048 W t \quad (8)$$

where Y is the length of the oleyl alcohol slick in meters, t is the time in minutes, and W is the wind speed in meters/minute. This equation together with equation (6) for the width of the slick constitute a pair of parametric equations which can describe the shape of a slick on the sea as a function of time. However, equation (8) is based on the assumption that the rate of lengthening is the same percentage of the wind speed for all wind speeds which has not yet been proven. Nevertheless it will serve to make approximations until a better equation is developed.

VII.1.3 Area Covered as a Function of Time: If a container of oleyl alcohol is thrown into the sea it begins to spread from a point source, but as time passes, the parametric equations predict that it assumes a shape similar to a parabola. A graph of the slick shape can be made if equation (6) is taken to describe the width of the leading edge and equation (8) is used to predict the distance of the leading edge from the slick dispenser. After solving the two equations simultaneously and integrating to find the area (see Appendix 1) the following expression for the area of an oleyl alcohol slick as a function of time is obtained:

$$A = 12.5 t^{3/2} + 0.137 W t^{7/4} \quad (9)$$

where A is the area in square meters and the other units are as in equation (8).

VII.1.4 Lifetimes of Oleyl Alcohol Marker Slicks: With an equation for the area of a slick affected by wind given as a function of wind speed and time, an equation for the lifetime of such a slick can be developed since the rate of loss of material from the monolayer should be proportional to the area it covers on the sea. Therefore,

$$\frac{dM}{dt} = KA \text{ and } M = K \int A dt \quad (10)$$

where A is represented by equation (9) and M is the mass lost from the slick at time t. When the mass is in grams and time in minutes with wind speeds in meters per minute the integrated expression for M is

$$M = 5 K t^{5/2} + 0.05 K W t^{11/4} \quad (11)$$

However, since we were fortunate enough to observe the disappearance of Slick No. 1, in the experiment of September 25, we know that at a wind speed of 355 meters/min and for a mass of 150 grams, t equals 78 minutes, so K could be computed to be 5.3×10^{-5} grams per square meter per minute. If constants are combined, the following expression for the mass loss from an oleyl alcohol slick as a function of time results:

$$M = 2.66 \times 10^{-4} t^{5/2} (1 + .01 W t^{1/4}) \quad (12)$$

where t is in minutes, M is the number of grams of oleyl alcohol dispensed and W is the wind speed in meters/minute.

The slick formed cannot have a lifetime greater than the time required for the amount of material dispensed to spread to the maximum area it can

cover. However, the slick will never reach its maximum area due to losses of material from the single-molecule-thick layer into the water and into the air. Also, starting from a point or a line source, the larger the area that the slick spreads over, the greater the loss, since the material in the monolayer is exposed to a greater volume of water and air. Therefore, small amounts of material dispensed onto the sea would be expected to approach their ideal maximum lifetimes, while larger amounts dumped at a single point would achieve a lower percentage of maximum predicted size. A comparison of characteristics predicted by the equations above to the characteristics observed in the experiment of September 25, 1975 are shown in Table 5.

Figures 14 and 15 have been prepared to illustrate the implications of the mathematical expressions. Figure 14 illustrates the amount of material lost from a slick as a function of time and wind speed as predicted from Equation 12. This graph can be used to estimate the amount of material required to produce a slick lasting for a desired number of hours at a given wind speed. For example, if a slick is desired to last for 5 hours in a 10 knot wind, approximately 6 kilograms of oleyl alcohol will be required according to Figure 14. The cross in the figure represents the observed lifetime of the 150 gram oleyl alcohol slick in the September 25, 1975 field experiment. The dissipation of the 2.5 kilogram (3-liter) slick occurred while the observation aircraft was away from the field experiment area but is believed to have happened 3 1/2 hours after dumping. The dashed line in Figure 14 represents the period during which the aircraft was away from the experiment area.

Figure 15 illustrates the sizes, shapes, and lifetimes of slicks formed from 150 grams of oleyl alcohol under different wind conditions according to equations 6, 8, and 12. The increase in the ratio

TABLE 5

PREDICTED AND MEASURED CHARACTERISTICS OF MARKER SLICKS OF SEPTEMBER 25, 1975

Characteristic	Slick No. 1		Slick No. 2	
	<u>Predicted</u>	<u>Measured</u>	<u>Predicted</u>	<u>Measured</u>
Grams of Oleyl Alcohol Released	-	2546.7	-	150
Minutes Elapsed Since Release	-	21	-	13
Slick Length in Meters	406 ^a	421	255 ^a	246
Width at Half Length (meters)	24.5 ^b	22	17.1 ^b	17
Area at Elapsed Time (meters ²)	11,209 ^c	9,262	4,909 ^c	4,182
Lifetime (minutes)	212 ^d	92-228 ^e	75 ^d	78
Area at Predicted Lifetime (m ²)	611,429 ^f	-	101,081 ^f	-
Theoretical Area at 33 dynes/cm with no losses	1,367,578 ^g	-	80,550 ^g	-
Theoretical Area at 1 dyne/cm with no losses	2,882,864 ^h	-	169,800 ^h	-

a) From equation (7)

b) Half the value given by equation (6)

c) Areas at elapsed times of 21 and 13 minutes computed from equation (9)

d) From equation (12) when the wind speed is 355 meters/minute

e) Not the average of the two values; could be 228. The aircraft was out of the operating area when Slick No. 2 disappeared

f) From equation (9)

g) No. of grams of oleyl alcohol times 537 square meters per gram

h) No. of grams of oleyl alcohol times 1132 square meters per gram

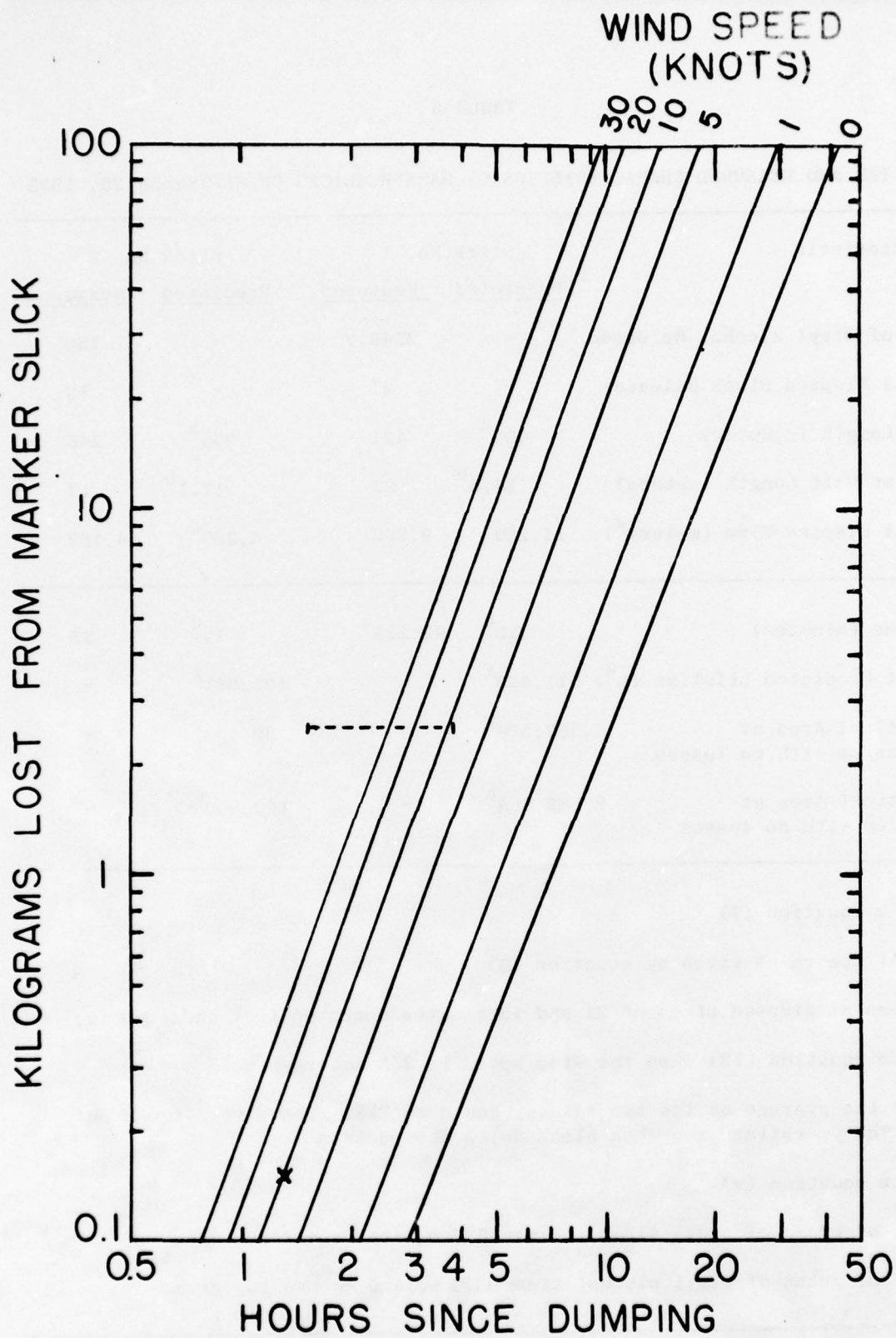

FIGURE 14. Predicted Lifetimes of Given Amounts of Oleyl Alcohol Dumped at a Single Point

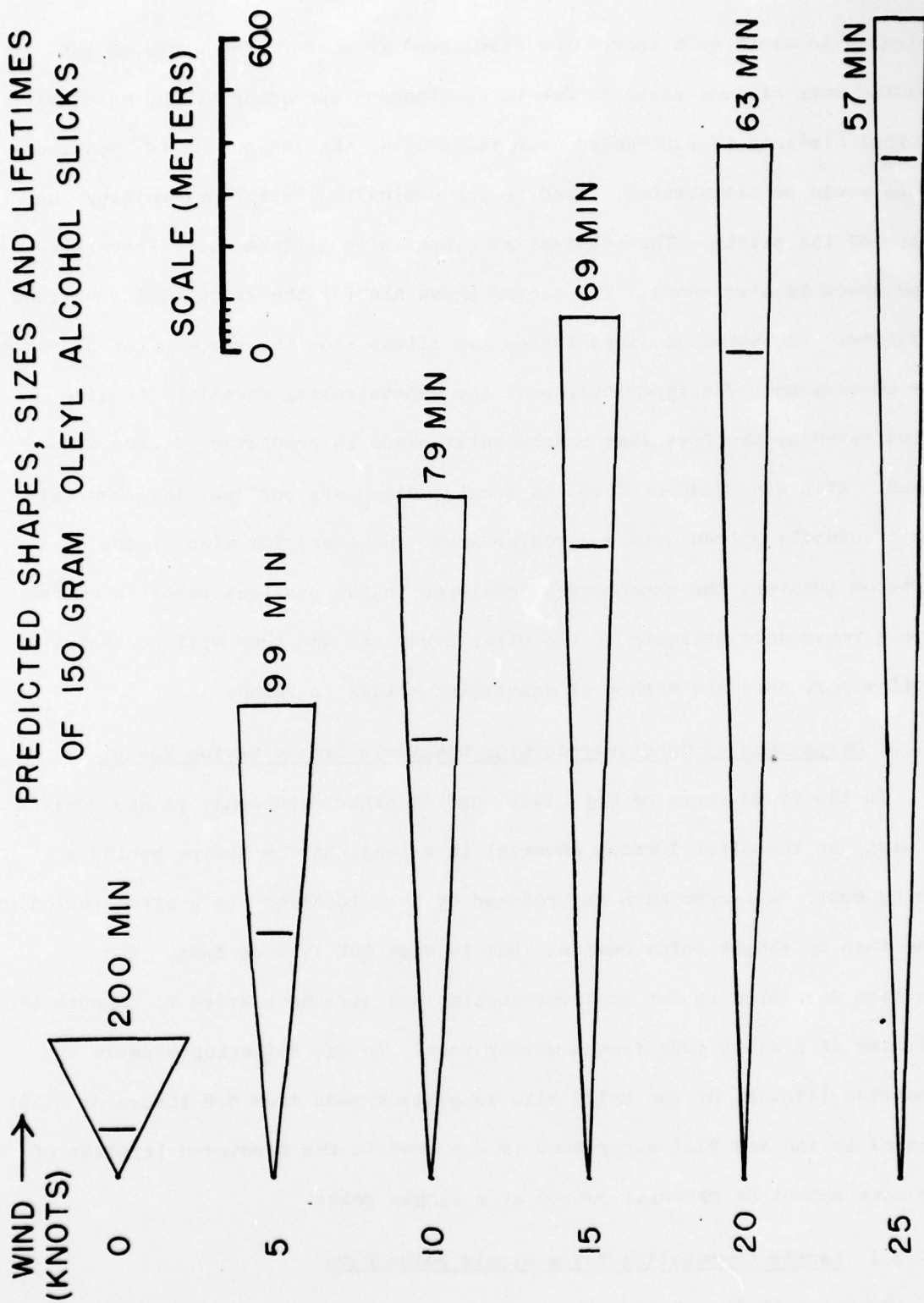

FIGURE 15. Sizes, Shapes, and Lifetimes Predicted for 150 grams Oleyl Alcohol Slicks Under Different Wind Conditions

of length to width with increasing wind speed is shown. The width of the leading edge of each slick is due to spontaneous spreading of the material. If that distance is subtracted from the length, the length due to the wind alone would be illustrated. Wind is the dominating factor determining the shape of the slicks. The substantial decrease in lifetime with increasing wind speed is also shown. The shapes shown are for the slick at its maximum lifetime. The vertical lines inside the slicks show the shape after 50 minutes for comparison. The imperfection of the approximating equations is also illustrated by the fact that a triangular shape is predicted at zero wind speed. At a windspeed of zero, on a calm, clean sea surface, the chemical would actually spread over a circular area. However, for wind speeds of 5 knots or greater, the expressions developed in the previous report seem to give a reasonable estimate of the slick behavior, and they will be useful until a more accurate method of describing slicks is found.

VII.2 Dispensing of Monolayer-forming Chemicals from a Moving Vessel

In the field tests of May, 1976, and on other occasions, it was desired to dispense the slick-forming chemical in a long, narrow stripe behind a moving boat. A larger mark is produced by this technique in a given period of time than by single point dumping, but it does not last as long. The equation developed in the previous section can also be adapted to compute the lifetime of a slick made from a moving boat. In the following example the predicted lifetime of the 2-1/4 mile long slick made from 4.9 liters of oleyl alcohol in the May 21st experiment is compared to the predicted lifetime of the same amount of material dumped at a single point.

VII.2.1 Sample Computation for a Single Point Dump

Equation 12 from the previous section can be used to compute the

lifetime of a slick made from a given amount of oleyl alcohol dumped at a single point:

$$M = 2.66 \times 10^{-4} t^{5/2} (1 + 0.01 W t^{1/4}) \quad (12)$$

where M is the amount of material dumped in grams, t is the time to disappear in minutes, and W is the wind velocity in meters/minute. If 4.9 liters of oleyl alcohol of density 0.8489 grams/ml were used, as in the field test of May 21, 1976, M would equal 4160 grams. Wind velocity on May 21 was 4 knots or 123.5 meters/minute, since 1 nautical mile is 1852 meters. From the equation above, t is found to be 359 minutes or about 6 hours.

VII.2.2 Sample Computation for a 2-1/4 Mile Long Stripe

If spreading is assumed to occur only in a direction perpendicular to the long axis of the slick, Equation 6 from the previous section can be used to compute the widening as a function of time.

$$X = 5.02 t^{3/4} \quad (6)$$

where X is in meters and the constant has units of meters/minute^{3/4}.

The area covered by the slick along a length of 1 meter as a function of time is therefore:

$$A = 5.02 t^{3/4} \quad (13)$$

where the units of the constant are meters²/minute^{3/4}. The 4.9 liters of oleyl alcohol were dispensed at a linear rate of 1.18 ml/meter or 1.002 grams/meter. For this simple approximation, spreading due to wind is neglected since the motion of the boat is the major spreading factor.

The amount of material lost into the water as a function of time (M) is proportional to the area of water surface covered as in equation 10 of the previous section:

$$\frac{dM}{dt} = KA, \text{ and therefore } M = K \int A dt \quad (10)$$

From the September 25, 1975, field experiment K was found to be 5.3×10^{-5} grams/meter² minute. Therefore, along a 1 meter length of slick

$$M_{1 \text{ meter}} = 4/7 \times 5.3 \times 10^{-5} \times 5.02 t^{7/4} \quad (14)$$

Since we know that 1.002 grams of material were dispensed along 1 meter of slick length, t could be computed to be 152 minutes or about 2-1/2 hours from the time dispensing stopped. The 4.9 liters of oleyl alcohol dispensed as a 2-1/4 mile long stripe would have an expected lifetime of less than half as long as the same amount of material dropped at a single point on the surface, although the mark made might be easier to detect because of its shape.

VII.3 Decreasing Film Pressure with Monolayer Expansion

The equations developed in the preceding section all stem from equation 4:

$$x = D t^{3/4}$$

which is valid when the spreading pressure is constant and makes D a constant. In actuality, once all the bulk material has spread to form a monomolecular layer at the equilibrium spreading pressure, the film pressure of the monolayer begins to decrease as shown in Figure 1 for oleyl alcohol. If the first stage of surface-tension spreading is called the constant pressure stage, the next stage could be called the decreasing pressure stage of the film spreading. Examining Figure 1 it is seen that theoretically, 1 gram of oleyl alcohol would expand to cover approximately 600 square meters of surface at the equilibrium film pressure of 33 dynes/cm, but during the further expansion to 1200 square meters the film pressure would drop to less than 1 dyne/cm. If equation 4 is

rewritten as

$$t = \left[\frac{X}{D} \right]^{4/3}$$

it can easily be seen that for a given distance the spreading time increases as the film pressure drops since D is a linear function of the film pressure. In the field this means that to an observer a slick appears to grow rapidly to a certain size and then persist at that size for a long time. The equations presented in the preceding section do not take the decreasing pressure phase of spreading into account when predicting slick size versus time. The equations assume that the film pressure remains at its maximum value and the derived constants reflect that assumption.

A more exact calculation would require the determination of an accurate equation for the force-area curve of the film-forming chemical. Force-area properties depend upon the molecular structure of the chemical involved so that there is no general equation. A set of equations valid only for oleyl alcohol could be developed, but would be rather complex. For the purposes of this project the developed equations seem adequate as indicated by the predicted and observed values listed for length, width, and lifetimes of the slicks listed in Table 5.

The equations developed in this report will help to predict the behavior of marker slicks dispensed on the sea surface in the presence of wind since no other detailed numerical method of estimating monolayer slick behavior on the open sea exists at this time. However, these equations will not give exact answers since several approximations were made to arrive at the coefficients used. Better numbers may be generated by future experiments. One area that needs more work is the more accurate prediction of monolayer slick lifetimes. This would require more study of the mechanisms by which the surface film

forming material is transported from the water surface into the water column and into the air, and of the rates at which these processes occur.

VIII. SUMMARY

A new technique of marking the ocean surface with monomolecular films in combination with dyes was studied in order to develop a practical sea marker which can be detected by airborne remote sensing devices in addition to visual observation. Monomolecular films of surface-active chemicals damp capillary waves on a body of water and can be used to make marks that are detectable day or night by radar. The area of damped waves is also visible to the eye even though the single-molecule-thick film itself is too thin to be seen. Since the film is so thin, a very small amount of material can be used to cover a large area on the sea surface with a detectable mark. On the basis of field tests during this study, past experience, and other considerations such as price, purity, possible toxicity, and chemical reactivity, oleyl alcohol was chosen as the most practical surface-active chemical for marking the sea surface with a monomolecular film.

Several water-soluble fluorescent dyes were examined for use in the dye marker package. The human eye is most sensitive to light at a wavelength of 555 nanometers which produces the sensation of yellow-green color. At wavelengths of 390 and 720 nanometers, the sensitivity of the eye is 1/1000 of the sensitivity at 555 nm¹⁵. Therefore, water-soluble dyes which emit light near 555 nm when excited by the light of the sun are visible to the eye in extremely low concentrations. Uranine, the dye traditionally used for sea dye markers, falls into this category (See Fig. 3) and is superior to dyes of other colors when it is desired to make the largest, most durable mark from the smallest amount of material. For this reason uranine was chosen for use in the combined

seamarker package. A different dye might be more easily detected by a remote sensing device if the maximum sensitivity of the particular device was at a wavelength other than 555 nm. In such a case a combination of two different water-soluble fluorescent dyes might be used to make a mark for search and rescue where a remote sensing device was used in addition to the human eye to sense the dye.

Oil-soluble dyes that are fluorescent when dissolved in a petroleum based oil or when dissolved in a vegetable oil based, monolayer-forming chemical were briefly examined as an alternative to a two-component package. In such a marker the dye would not be lost by diffusion into the water like water-soluble dyes are. However, the volume of oil required to make this kind of mark was judged to be excessive, since even a thin layer of oil contains a surprisingly large volume when spread over an area of practical size for a seamarker. For example, a circular patch of oil 4 meters (approximately 13 feet) in diameter and 1 millimeter thick requires 12.6 liters of oil (nearly 13 quarts). The area doubles whenever the thickness decreases by half, but the surface concentration of oil-soluble dye (grams/cm^2) also decreases by half. When viewed from above, this kind of fluorescent dye mark appears to dissipate as the oil spreads, even though the dye does not actually change its concentration in the oil. The oil film simply gets thinner as it spreads until the color is no longer visible. It is possible to retard the spreading of the oil medium with chemical additives, but the volume requirement is still a problem. The sea serves as the medium for water-soluble dyes, of course, so there is no thinning problem when they are used. Observations made in this study indicated that a given amount of water-soluble fluorescent dye can make a larger and more durable mark than the same amount of oil-soluble dye dissolved in an oil medium. There-

fore, the two-part package of a water-soluble fluorescent dye and an insoluble monolayer-forming chemical was judged to be a more practical seamarker.

Laboratory tests revealed that the water-soluble dyes lose their fluorescence when dissolved in solutions of strong acids or bases. Since some of the waste solutions routinely dumped at sea are strongly acidic while others are of unknown composition, materials used to mark the location of ocean dumping activities for surveillance should be dispensed separately rather than being added to the waste holding tanks for discharge with the material being dumped. Separate dispensing will assure that a mark is made for each dumping by eliminating the possibility of the seaming material reacting with the waste material while being transported to the dump site.

A prototype package for a hand-held marker which dispenses both dye and monolayer-forming chemicals was designed and tested in the field. Repeated single point dumps of larger quantities of the slick-forming chemical or a dye solution can be made from a prototype device that was designed to mark ocean dump sites. In addition, a prototype pressurized dispenser was developed for dispensing slick-forming chemicals behind a moving boat to make long stripes of damped capillary waves during field tests with airborne radar.

In a field test in the Atlantic Ocean, a combination hand-held marker containing 150 grams of oleyl alcohol and 100 grams of powdered uranine dye produced a visible dye mark in addition to a triangular monolayer slick 246 meters long and 34 meters wide at the base, covering an area of 4,182 square meters after only 13 minutes (see Table 5). The slick continued to grow in size and persisted for 78 minutes in a 10-13 knot wind. The region of damped

capillary waves was easily visible from the air when the distance was too great to see the much smaller dye mark. The dye positively identified the slick as a deliberate mark, distinguishing it from other natural slicks or oil slicks. From some viewing angles the slicks was visible when the dye was not, and from other angles the dye was visible when the slick could not be seen. The combination of the two is recommended over either one alone.

Based on the laboratory and field data a series of mathematical equations was developed to approximate the shapes, sizes and lifetimes of monolayer slicks under different wind conditions. These equations allow the proper amount of monolayer-forming material to be chosen to make a mark of desired size or lifetime. Practical seamarkers using monolayer-film-forming chemicals in combination with water-soluble fluorescent dyes can be produced for marking objects or activities on the sea surface. The information in this report can be used to produce a dye/slick seamarking device tailored to a specific need. Additional field testing of the detectability of dye/slick combination seamarkers by remote sensing devices is recommended so that the markers can be optimized for use with the specific remote sensing devices adopted for routine use.

IX. APPENDIX I

DERIVATION OF THE EXPRESSION FOR AREA AS A FUNCTION OF TIME

1) $A = 2(xy - \int y \, dx)$ see figure at right

2) $x = (5/2)t^{3/4}$ see text p. 54

3) $t = (2/5)^{4/3} x^{4/3}$

4) $y = 5 t^{3/4} + 0.048 W t$ see text equation (8)

5) $y = 2x + 0.048 W (2/5)^{4/3} x^{4/3}$

6) $xy = 2x^2 + 0.048 W (2/5)^{4/3} x^{7/3}$

7) $\int y \, dx = x^2 + (3/7) (0.048) (W) (2/5)^{4/3} x^{7/3}$

8) $A = 2 \left[x^2 + (4/7) (0.048) (W) (2/5)^{4/3} x^{7/3} \right]$

9) $A = 2(5/2)^2 t^{3/2} + (8/7) (0.048) (W) (2/5)^{4/3} (5/2)^{7/3} t^{7/4}$

10) $A = 12.5 t^{3/2} + 0.137 W t^{7/4}$

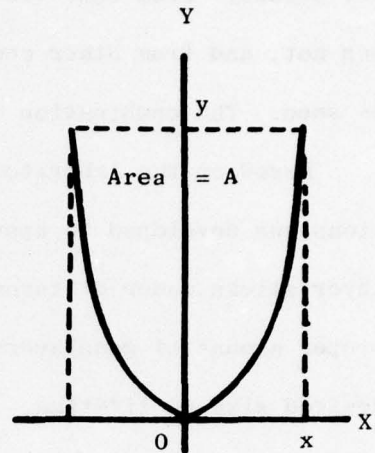

X. REFERENCES

1. Ard, R. W., Coast Guard's Response to Spilled Oil, *Environmental Science and Technology* 10 (3): 239-242 (1976).
2. Barger, W. R. and W. D. Garrett, Modification of the Air-Sea Interface by Artificial Sea Slicks, Naval Research Laboratory Report No. 6762, Sept. 18, 1968.
3. Gurr, Edward, *Synthetic Dyes in Biology, Medicine, and Chemistry*, Academic Press, New York, 1971.
4. Kantardzhyan, L. T., Variation of the Luminescence Spectrum of Uranine with the pH of Seawater, *Bull. Akad. Sci. SSSR*, 23: 125-128 (1959).
5. Torgerson, R. E., and R. J. Boubanger, Visual Location Aids Study Program Final Report, Northrop Ventura Report No. 2779, August, 1964, (NASA Contract No. 9-482).
6. Garrett, W. D., and W. R. Barger, "Chemical Sea Surface Marker," U.S. Patent 3,676,359 (July 11, 1972).
7. Barger, W. R., and W. D. Garrett, Artificial Sea Slicks: Their Practical Application and Role in Fundamental Research, Naval Research Laboratory Report No. 7751, June 4, 1974.
8. Jarvis, N. L., W. D. Garrett, M. A. Scheiman and C. O. Timmons, Surface-Active Chemical Characterization of Surface-Active Material in Seawater. *Limnology and Oceanography* 12 (1): 88-96 (1967).
9. Garrett, W. D., The Organic Chemical Composition of the Ocean Surface, *Deep-Sea Research* 14: 221-227 (1967).
10. Garrett, W. D., and W. R. Barger, Control and Confinement of Oil Pollution on Water with Monomolecular Surface Films, NRL Memorandum Report No. 2451, June 1972.

11. Gaines, G. L., Insoluble Monolayers at Liquid-Gas Interfaces, Interscience Publishers, New York, 1966.
12. Reed, A. W., Ocean Waste Disposal Practices, Noyes Data Corp. Park Ridge, N. J., 1975, pp. 296-297.
13. Fay, James A., Physical Processes in the Spread of Oil on a Water Surface, Proceedings of the Joint Conference on Prevention and Control of Oil Spills, Washington, D. C., June 15-17, 1971, pp. 463-467.
14. Garrett, W. D., and W. R. Barger, Factors Affecting the Use of Monomolecular Surface Films to Control Oil Pollution on Water, Environmental Science and Technology 4, 123-127 (1970).
15. Isotables, A Handbook of Data for Biological and Physical Scientists (5th Edition), Instrumentation Specialties Co., Lincoln, Nebr., 1974.

ACKNOWLEDGEMENTS

We would like to thank all those who contributed to the success of the field experiments. The assistance given is greatly appreciated. Mr. E. R. Russ of the NRL Chemical Oceanography Branch aided in conducting the experiments in the Chesapeake Bay and in the Pacific Ocean. Dr. Hollinger and his group from the NRL Space Sciences Division graciously shared their research aircraft for photographic purposes during the Atlantic tests in which LT Maurer of the U. S. Coast Guard Office of Research and Development released the markers for us from aboard the Coast Guard vessel Cherokee. LTJG Wiley of the Coast Guard Air Station, San Francisco, arranged the Pacific field tests in cooperation with Mr. D. E. Mulligan of the Motorola Government Electronics Division and Dr. Kraus of the Department of Geography, University of California at Santa Barbara. LTJG Elliot and the crew of the Point Judith from Santa Barbara and LTJG Adams and the crew of the Cape Hedge from Morro Bay were quite helpful in conducting the Pacific Ocean field tests. Dr. G. I. Loeb of the NRL Marine Biology and Biochemistry Branch ran the Fluorescence Spectrophotometer to determine the spectra shown in Figures 2, 3, and 4.