

ADA037216



12
WU



DDC
RECEIVED
MAR 22 1977
WU

DISTRIBUTION STATEMENT A
Approved for public release;
Distribution Unlimited

DOW CHEMICAL U.S.A.

An Operating Unit of The Dow Chemical Company

WALNUT CREEK, CALIFORNIA

COPY AVAILABLE TO DDC DOES NOT
PERMIT FULLY LEGIBLE PRODUCTION

12

9 FINAL TECHNICAL REPORT. 27 Mar 73 - 6 Oct 76

6 RESEARCH & DEVELOPMENT OF THE GLASS FIBER SODIUM-SULFUR BATTERY.

and Contract No. DAHC-15-73-C-0254

15 Sponsored by

Advanced Research Projects Agency

ARPA Order No-2381

DDC
RECORDED
MAR 22 1977
REGISTERED
A

Submitted by

Dow Chemical Company USA
Walnut Creek, California

11 6 Oct 76

12 5 1/2 p.

Approved for public release;
Distribution Unlimited

Program Code 5D10
Effective Date: March 27, 1973
Expiration Date: October 6, 1976
Contract Amount: \$779,617

10 Charles Levine
Principal Investigator
Phone: 415-944-2034

408749

4B

TABLE OF CONTENTS

	<u>Page</u>
ABSTRACT	3
SUMMARY	4
I. PURPOSE	4
II. CONCLUSIONS	4
A. Technical Problem	4
B. General Methodology	4
C. Technical Results	5
D. Comments	7
INTRODUCTION	7
RESULTS	10
I. Causes of Premature Cell Failure	10
1. Harmful Impurities in the Anolyte	10
2. Harmful Impurities in the Catholyte	20
3. Minimizing Weakening of the Fibers at the Tubesheet	25
II. Testing of Cells and Scaling Up	27
III. Thermal Cycling the Cell	40
IV. Design and Construction of a Metal Case for the Cell	41
V. Improve Fabrication Operations	43
1. Glass Fiber Spinning	43
2. Tubesheet Material	43
a. Tubesheet Fines	43
b. Tubesheet Spheres	44
3. Sodium-Sulfur Fill Station	45
4. Electrical Cell Testing Apparatus	45

ABSTRACT

Development work on the sodium-sulfur rechargeable cell which uses the walls of fine hollow glass fibers as the electrolyte has led to much longer lasting cells capable of thousands of deep and rapid cycles. The longest lived multi fiber cell to date, cycling at over 90% depth, has undergone over 2300 cycles in 92 days and is still in operation. This cell should be capable of over 220 watt hours per kg.

Cell life is shortened by certain impurities in the Na, by nonfused tubesheets, and by fibers weakened during processing. Removal of these harmful effects, problems in scaling up cell size, in developing a metal case for the cell, in thermal cycling, and in fabrication of the cell parts are described.

ADDRESS	
DATE	
BY	
<i>Letter on file</i>	

SUMMARY

I. PURPOSE

This is the final report on the Research and Development Program directed generally at development of the sodium-sulfur rechargeable cell which uses the walls of fine hollow glass fibers as the electrolyte. This cell has the potential of giving thousands of deep charge-discharge cycles at energy densities of about 220 watt hours per kilogram and power densities of over 180 watts per kilogram. It is capable of very rapid recharge as well as discharge if necessary. The cost should be moderate. With these features, innumerable applications within the DOD can be envisioned.

Since this work was done in conjunction with parallel programs supported by Dow Chemical Company, ERDA, and NASA, certain specific tasks were outlined for the ARPA program. This report, while emphasizing the progress since the last technical report, (Semi-Annual Technical Report, July 1, 1976), will cover the work done during the contract period. It will also summarize briefly the work done toward the Na-S battery development which was sponsored by the other Agencies and Dow.

II. CONCLUSIONS

A. Technical Problem

Important progress was made in evaluating, improving, and scaling up the hollow fiber sodium-sulfur cell. The goals included achieving at least 1000 cycles of charge-discharge operation, building larger cells capable of long lifetimes, determining operating parameters at various rates of charge-discharge, and attempting to thermally cycle the cell. Some of the more specific tasks were to find the causes of cell failures, to minimize weakening of the glass fibers at the fiber-tubesheet juncture, and to improve the back-up processing of parts and fabrication operations.

B. General Methodology

The problems were attacked in a variety of ways. To find specific effects of impurities or to test certain components, special devices were constructed which would test only that factor.

For example, to test the effect of impurities in the anolyte and catholyte on the fibers, special "dianode assemblies" were built that would emphasize any such effects. Results of these tests were then used to improve on the design or operation of actual multi-fiber cells. Multi-fiber cells were made in a number of different sizes, ranging from a few fibers to over 15,000 fibers. Most of the testing was done with 0.5 ampere-hour cells (~1000 fibers), 6 ampere-hour cells (~3000 fibers), and 40 ampere-hour cells (15,000 fibers).

Cell failures were analyzed, and, where possible, the causes of these cell failures led to further work on how to prevent these causes.

Some cells were operated at up to 25 times the design current density to try to accelerate failures. Some single fiber assemblies were operated at up to 60 times the design current density.

C. Technical Results

Lifetimes of multi-fiber cells have been greatly increased during this Contract work from about 3 weeks to over 7 months. Actual lifetimes are now as follows:

0.5 ampere-hour cell: >3 months at over 75% depth of discharge,
1/2 hour rate

>7 months at 25-60% depth of discharge

6 ampere-hour cell; 28 days at over 80% depth of discharge

These increases in lifetimes came about by analysis of the failure mechanisms. Impurities in the sodium (Ca, oxides) cause degradation of the glass fiber. An impurity in "flowers of sulfur" that can easily be filtered out causes fiber degradation. Some cell failures were due to porous tubesheets which allowed sodium to enter the sulfur chamber. Methods of removing the harmful impurities and completely fusing the tubesheet were developed.

By running cells at high currents, up to 50 ma per cm² of glass -- compared to design currents of 2 ma per cm² -- it was determined that passage of current through the glass did not cause glass degradation. Total currents equivalent to 10 years of normal life could be passed through the glass without failure.

Charge-discharge cycling per se does not harm the cell. One cell, run at only 6% depth of discharge but at a high 1/2 hour rate, cycled over 77,000 times with eventual failure due to another cause.

An on-going problem of the glass fibers being weakened at their juncture with the tubesheet during tubesheet fusion has been partially alleviated. Fusion of the tubesheet at the lowest possible temperature and the use of BCl_3 gas to treat the tubesheet just before fusion result in the fibers being less brittle. Improvements still should be made.

In principle, scaling up the cells to larger sizes should be easy. In practice, the larger cells have shorter lifetimes. The 1000 fiber cell has over 3 months of continuous operation at 80% depth of discharge, while the 3000 fiber 6 ampere-hour cell has 28 days of similar operation and the 15,000 fiber 40 ampere-hour cell has been limited to 2 weeks of operation. The reason for this is not clear. There are many more strains put on the larger cells during assembly. It is possible that these strains weaken the fibers.

Attempts were made to thermally cycle the cells. The cells could be cooled and reheated without damage so long as the sodium anolyte and the catholyte remained molten. Therefore, with the battery in the fully charged state (catholyte is mostly sulfur), the cell could be cooled to 120°C and reheated to 300°C without harm. Upon cooling to room temperature and solidification of the reactants, the cell failed.

Much work and many improvements were made in the "back-up" fabrication of cell components. The ability to spin the hollow fibers was greatly improved by recognizing the importance of and controlling the spinning temperature and the stability of the fiber take-up assembly. Instead of being limited to the usual 10-15 μ wall fiber, fibers with walls of 6 μ and 3 μ could be made. A cell made using the 6 μ wall had a lifetime as long as the best cells using 10 μ wall fibers.

The production of reproducibly good tubesheet material has been a continuing problem. The low melting solder glass used must be finely ground and treated so that it can be made into a high solids content extrudable paste. The effects of surface water, amine grinding aid, and amine suspension agent have been drastic and non-reproducible.

Much effort has gone into trying to put the cells into stainless steel cases. Only a few were successfully assembled. Problems were encountered in attaching the anode cup and in the ability to weld the final case enclosure without putting great strains on the internal cell assembly. Those cells which were assembled ran 25-28 days continuously with normal charge-discharge characteristics.

Filling of the cells with sodium and sulfur cannot be done economically in a controlled atmosphere box. A filling assembly was designed and built to allow filling the completed cell in a non-controlled atmosphere. The sulfur side works fine, but the sodium side plugs with oxide.

A cell testing stand was built which allows the testing of 5 cells (expandable to 25 cells) at various rates of charge-discharge cycling. Cell voltages and resistances are monitored and printed out periodically.

D. Comments

The work under this Contract has been fruitful and rewarding. Much progress has been made toward making possible a very high energy density rechargeable cell capable of rapid charge and discharge. The next step in the work would be to make multi-cell batteries from these individual cells for specific applications such as power storage, vehicular propulsion, central station power, etc. The advice and the encouragement of Dr. Stanley Ruby has been invaluable.

INTRODUCTION

The work described here is aimed at the development of a new improved battery based on sodium and sulfur as the anolyte and catholyte and using the thin walls of hollow glass fibers as the electrolyte. In the course of this work, the cell has been developed to the extent of showing thousands of reproducible deep charge-discharge cycles with no loss in capacity, and lifetimes of the order of 4-7 months. Failure mechanisms are still being determined. Practical energy densities of operating batteries of 220 watt-hours per kilogram can be calculated using the experimental results. The program envisioned that when cell lifetimes of over one year could be shown, cells would be connected in series and parallel to make batteries.

The experimental results will be described as follows:

- I. Causes of Premature Cell Failure
 1. Harmful impurities in the anolyte
 2. Harmful impurities in the catholyte
 3. Minimizing weakening of the fibers at the tubesheet
- II. Testing of Cells and Scaling up
- III. Thermal Cycling
- IV. Design and Construction of Metal Case Cell
- V. Improve Fabrication Operations

THE DOW SODIUM SULFUR HOLLOW FIBER CELL

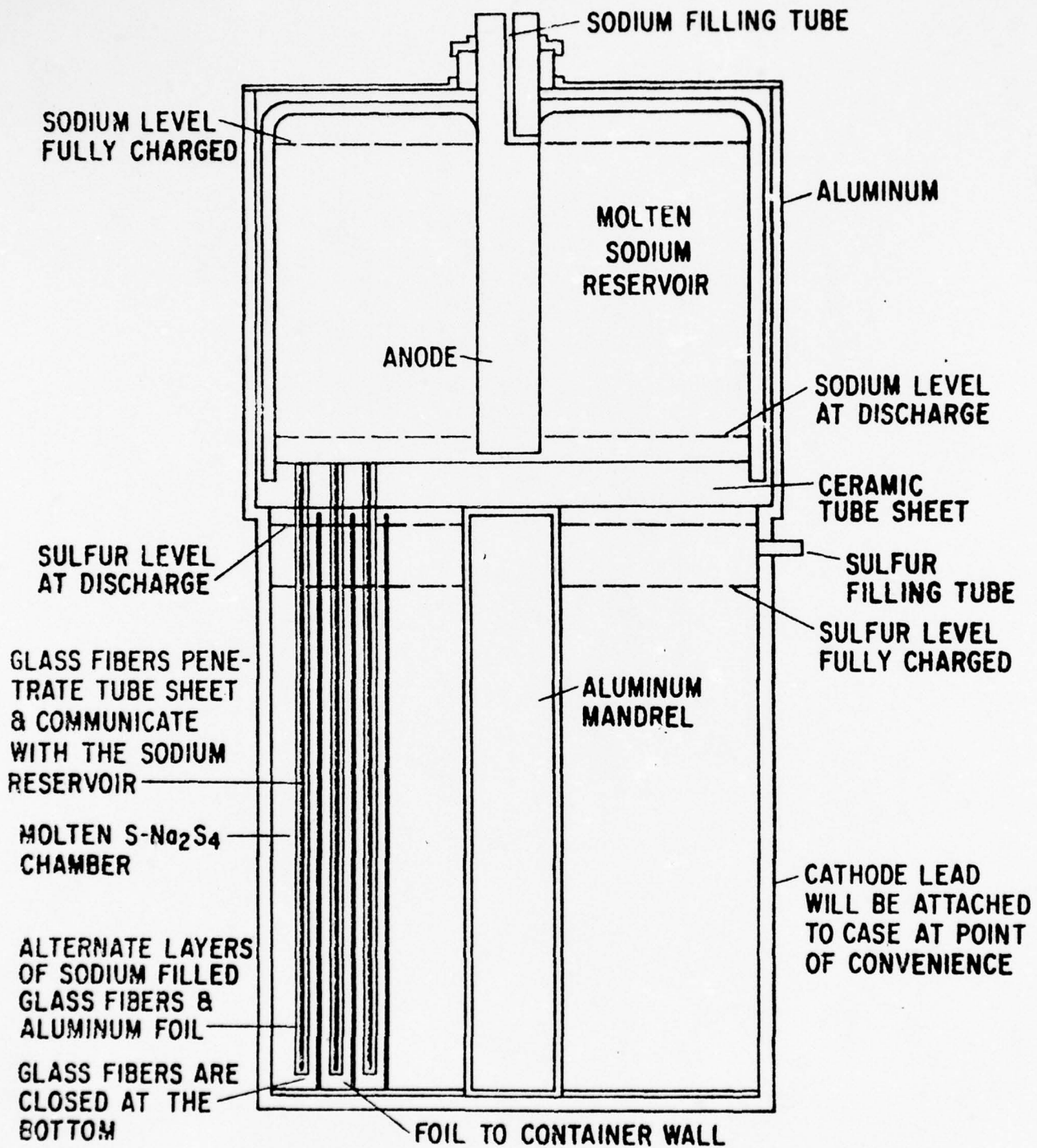

40 AMP HOUR UNIT

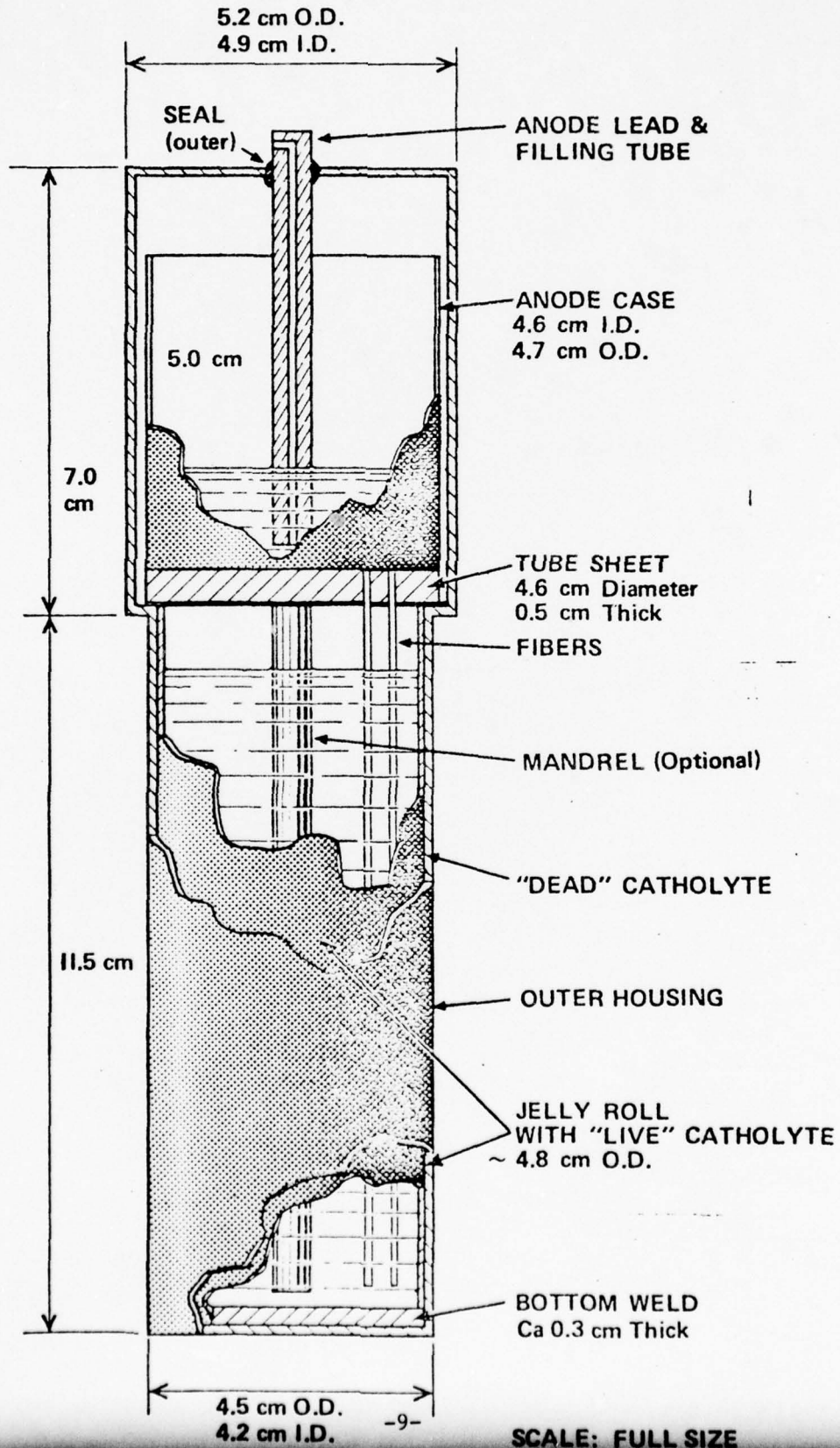

Figure 1 is a drawing of the cell showing the component parts. The glass fibers are generally $50 \times 70\mu$ or $50 \times 80\mu$, with fiber wall thicknesses of $10\text{-}15\mu$. The 40 ampere-hour cell shown in Figure 2 has approximately 15,000 fibers.

RESULTS

I. Causes of Premature Cell Failure

1. Harmful Impurities in the Anolyte

A number of impurities in the sodium were found to cause degradation and breaking of the glass fibers. Figure 3 shows the "dianode assembly" used to accelerate the effects of harmful impurities. Two anode assemblies, each consisting of one to ten fibers attached to an anode reservoir, are immersed in a common sulfur-sulfide pool. One of the assemblies can be continuously "discharged" while the other assembly is "charged". Changes of electrode resistance can be measured and located by the use of a reference electrode in the sulfide catholyte.

Figure 4 shows what happens to the electrode resistance during a continuous passage of current when the sodium contains 0.04% calcium. The "discharging" electrode increases steadily in resistance while the resistance of the "charging" electrode remains fairly constant. The glass membrane of the electrode which increases in resistance eventually breaks. The calcium, as Ca^{++} , probably either enters the glass structure causing strains or else blocks the current passage -- in either case causing higher resistance and strains. Figure 5 shows the lack of any resistance increase when the calcium content of the sodium used has been reduced to .0015%. When this dianode assembly is cycled with charge-discharge reversals every hour, long term stability is seen. Figure 6 shows that the resistances at both electrodes are fairly constant over 2 weeks of operation on the low Ca sodium. The initial drop in resistance is attributed to the initial wetting of the glass by the sodium.

The other impurities in the sodium are potassium and "oxides". Potassium is generally present in sodium to the extent of about 140 ppm. Figure 7 shows the resistance increase on the discharging electrode with various concentrations of potassium in the sodium. The potassium apparently builds up in the glass to some steady-state concentration (and resistance increase) depending on its concentration in the sodium. On continued operation of these dianode assemblies, the fibers did not break. Apparently 130 ppm K in the sodium is not harmful.

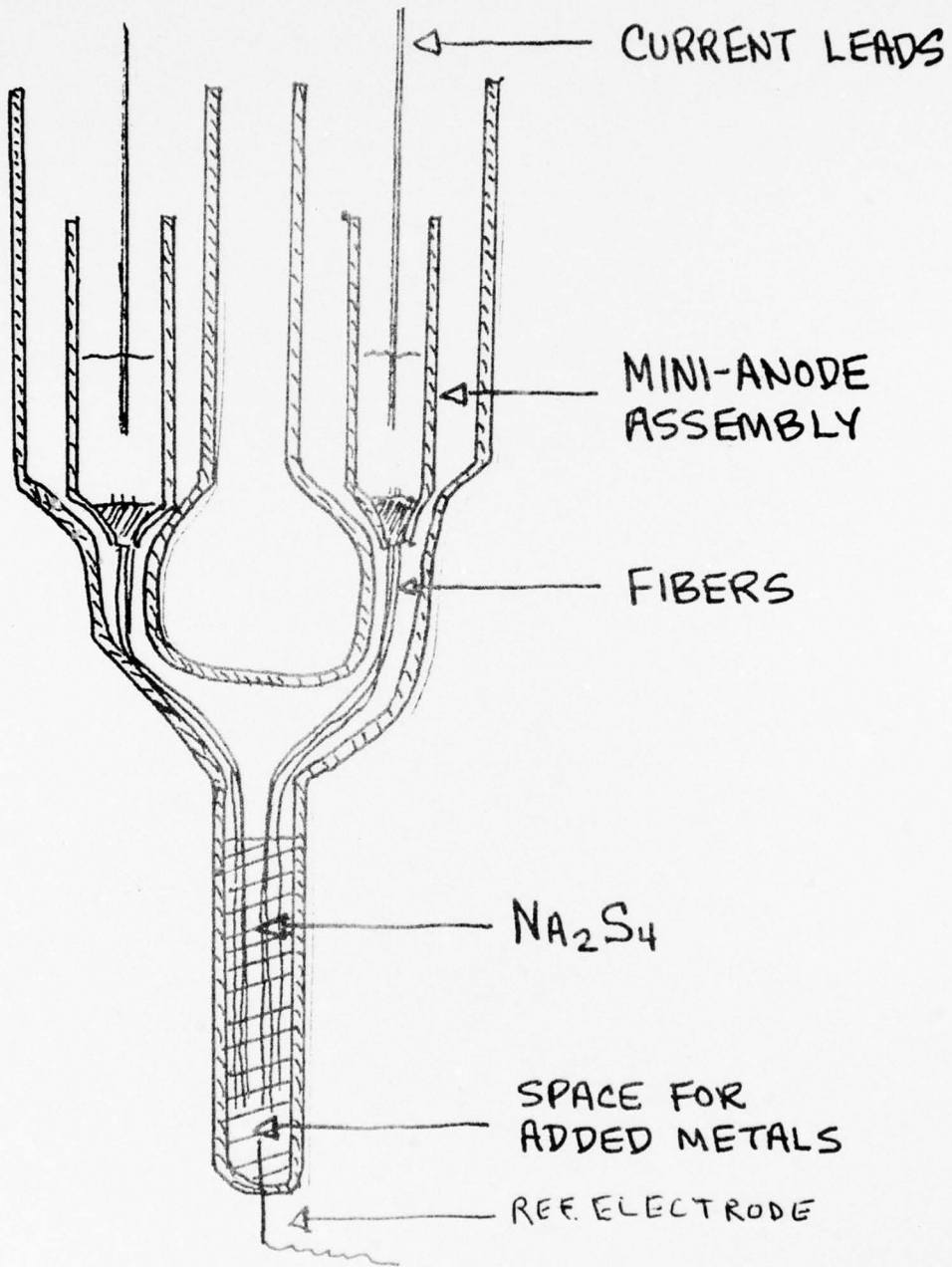

DI ANODE ASSEMBLY

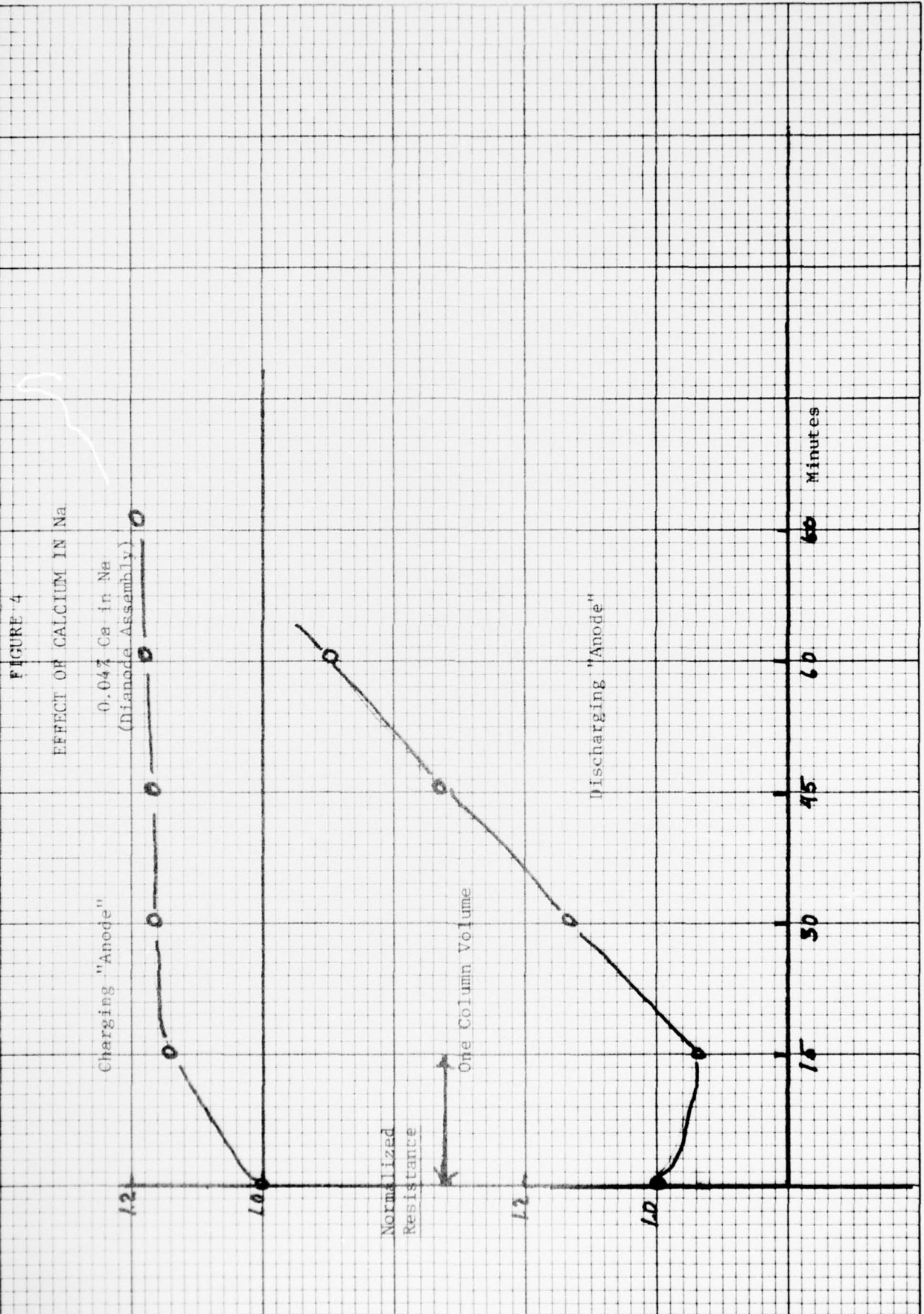
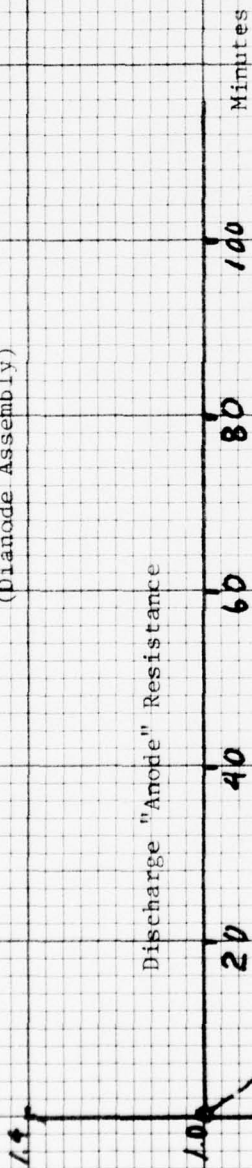

FIGURE 5

EFFECT OF Ca-FREE Na ON RESISTANCE

0.0015% Ca in Na
(Diode Assembly)



Relative Resistance



Minutes

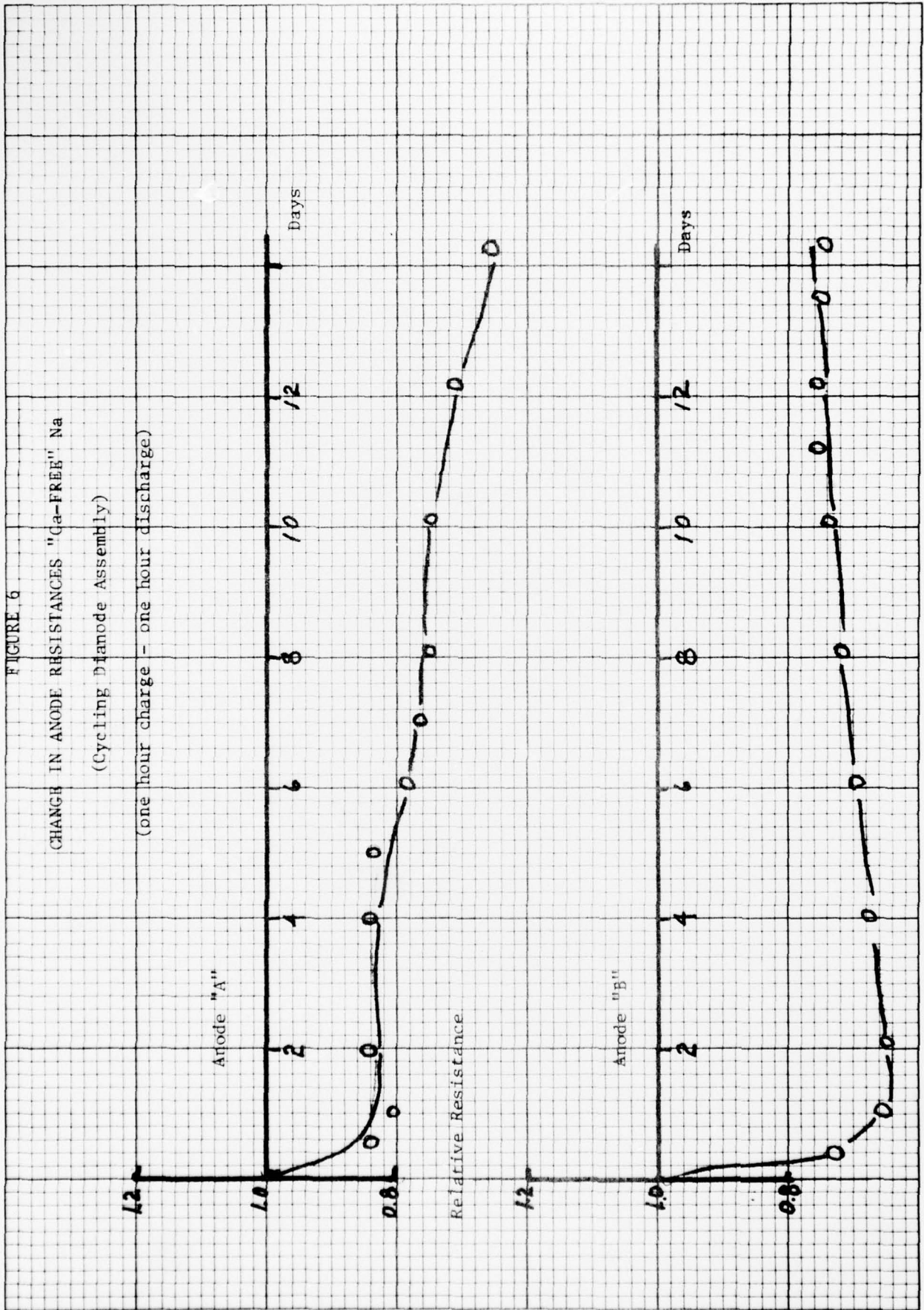

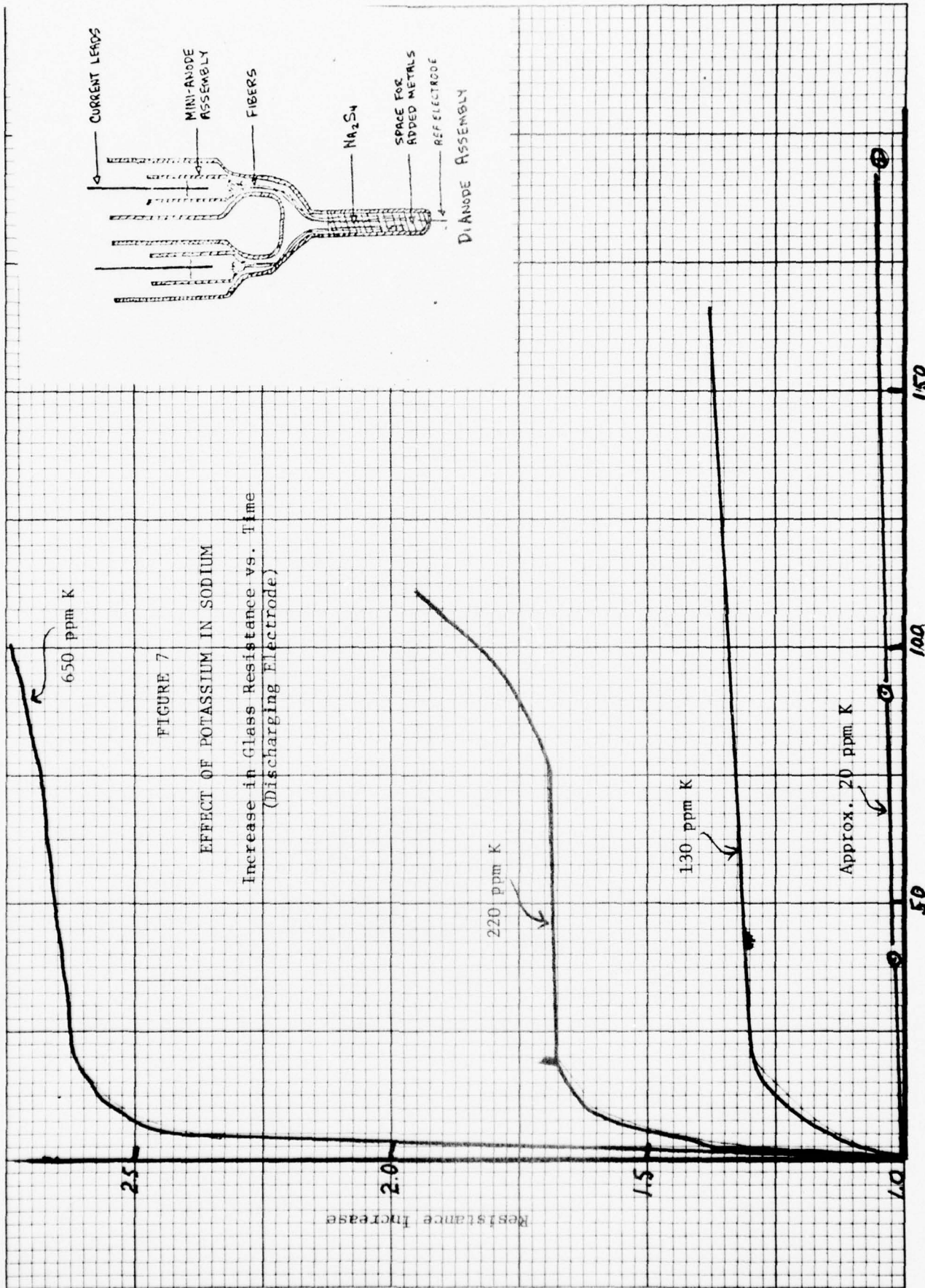

Oxides in sodium can exist as several species. The action of the oxides is to physically corrode the glass fibers. The actual mechanism of corrosion is not known. Experimentally, when sodium which contains over a few ppm of oxide is used in the dianode assembly, the fibers in the discharging anode break after extended discharge. Examination of the broken fibers shows the upper portion of the fiber to be clean and strong. It appears to be pristine on microscopic examination. The broken bottom portion of the fiber has a badly corroded internal surface.

As the sodium is discharged through the glass wall, the oxide stays behind and is concentrated in the molten sodium. The concentration of the oxide near the bottom of the fiber builds up to approximately $C = C_0 e^{-n}$ where C_0 is the initial concentration and n is the number of column volumes of sodium discharged. The oxide precipitates out and causes degradation of the fibers.

Methods were developed for removing the calcium and the oxides from the sodium. These are described in detail in previous reports. The calcium is removed to below .0015% by digesting the sodium with excess Na_2O and filtering:

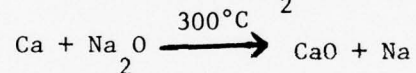

After filtration, the oxides are removed to "a few" ppm or less by treating the sodium with Zr-Ti alloy at 500°C . The final oxide is removed by titration with a solution of barium in molten sodium using a sodium-filled glass capillary as an indicating electrode. This is described in the Semi-Annual Report to ARPA, July 1, 1976.

Lifetimes of the cycling dianode assemblies were increased by the removal of oxides. Table I shows the results. These assemblies were operated at 13 to 25 times the normal current density in order to induce rapid failure. Removal of the oxide from "a few ppm" to the "scavenged oxide" level resulted in a life increase of 300-400% in ma-hours per cm^2 of current passed. Note also that the failures are now not fiber failures but due to another cause.

It is interesting to note that the passage of 28,000 ma-hours per cm^2 corresponds to 14,000 hours or 580 days at the design current of 2 ma per cm^2 .

Although the sodium when introduced into the cell is pure, it picks up oxide from the water which is contained in the glass fibers and the glass tubesheet of the cell.

TABLE I

LIFETIME OF CYCLING DIANODE ASSEMBLIES

<u>Ungettered Na (0.6 ppm Ca)</u>			<u>Life</u>
<u>Cell No.</u>	<u>Current Density</u>	<u>Days</u>	<u>ma-hr/cm²</u>
DA-30	28.5 ma/cm ²	9	6,150
DA-31	26.6 ma/cm ²	10	6,400
DA-33	25.8 ma/cm ²	10	6,200

(All failures are fiber failures)

<u>Gettered Na (0.6 ppm Ca)</u>			<u>Life</u>
<u>Cell No.</u>	<u>Current Density</u>	<u>Days</u>	<u>ma-hr/cm²</u>
DA-51	47.4 ma/cm ²	17	19,400
DA-52	52.0 ma/cm ²	20	25,600
DA-54	55.0 ma/cm ²	21	28,150

(No fiber failures; all failures are in the tubesheet region)

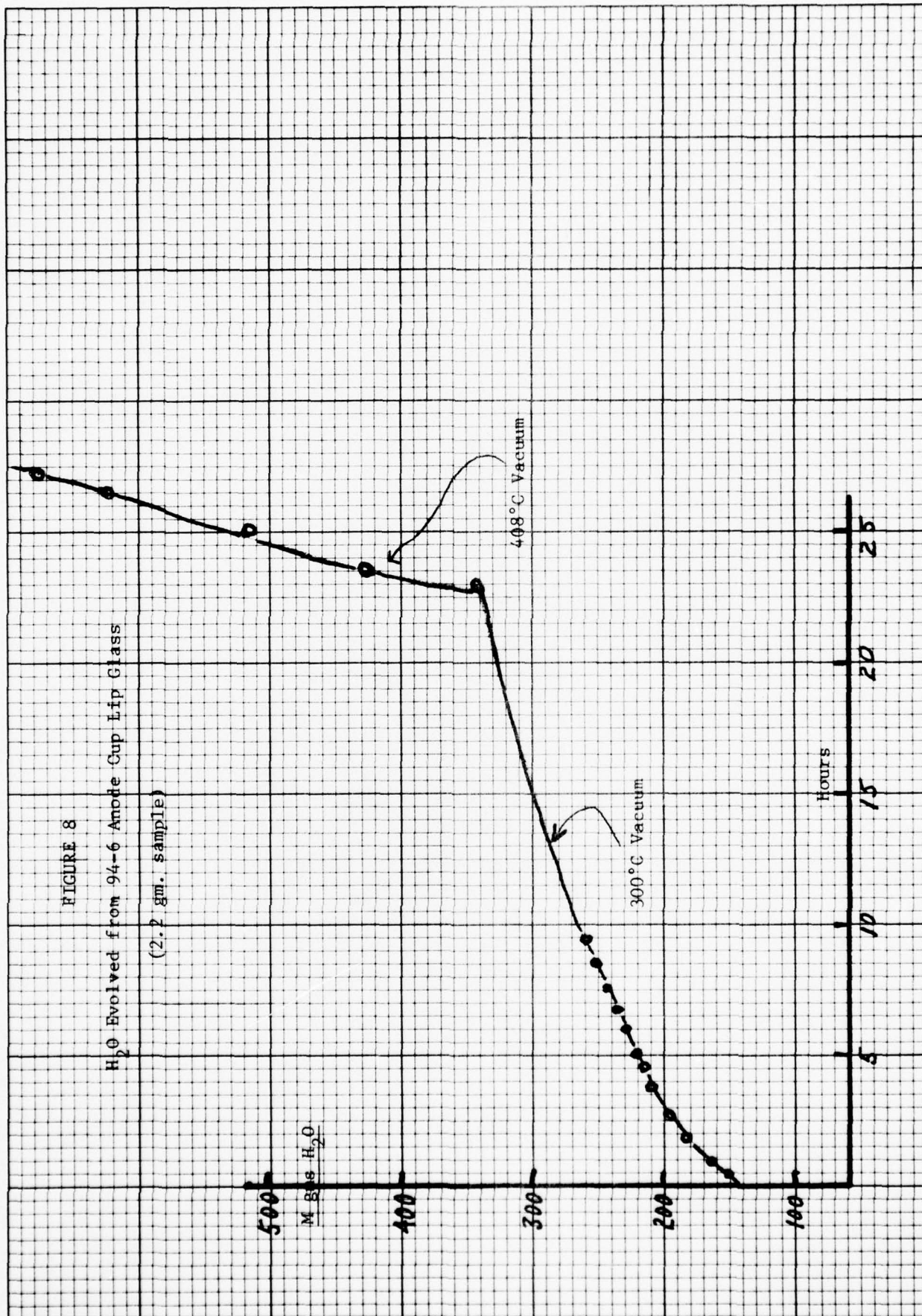

This water, at the cell operating temperature, slowly diffuses out of the glass and is picked up by the sodium. Experiments were run to determine the rate at which the water migrates out of the glass. A 2.2 gram sample of the glass from the lip of the anode cup was held at 300°C under vacuum and the water evolved was measured. After 23 hours, the temperature was raised to 408°C. Figure 8 shows the result.

Water is released slowly over a long period of time. The diffusion coefficients for water in both the tubesheet glass and the fiber glass were measured. They are:

$$\begin{aligned} D_{\text{H}_2\text{O}} \text{ (tubesheet glass)} &= 5.8 \times 10^{-11} \text{ at } 300^\circ\text{C} \\ &9.4 \times 10^{-10} \text{ at } 370^\circ\text{C} \\ D_{\text{H}_2\text{O}} \text{ (fiber glass)} &= 4.0 \times 10^{-10} \text{ at } 318^\circ\text{C} \\ &2.8 \times 10^{-9} \text{ at } 412^\circ\text{C} \end{aligned}$$

Since the tubesheet glass normally has a higher moisture content than the fiber glass, and the diffusion coefficient is lower, the water diffuses to the glass fiber walls, through the walls, and into the sodium contained in the fibers. In order to scavenge out this residual "bulk" moisture content of the glasses, some Zr-Ti alloy is added to the sodium in the anode cup to act as an "in-situ" scavenger.

2. Harmful Impurities in the Catholyte

Normally, the sulfur used in the cells and interesting is purified by distillation over Vycor chips held at 850-900°C after filtering. The distillation should remove the solids and the high temperature reacts the organics to CS₂ and H₂S.

In order to test the effects of impurities in the sulfur, sulfide made from this purified sulfur was spiked with the impurity to be tested. The survey tests were run in the dianode assembly so that the effect of the impurity could be isolated as taking place on the charge or the discharge cycle.

Small amounts of MgS, ZnS, Al₂S₃, and H (from NaH or NaHSO₄), were individually added to the sulfide. Changes in glass resistances were determined on both the charging and discharging electrodes during extended operations with the use of the reference electrode. Only in case of the NaH impurity was any difference from the control seen. Figure 9 shows a rise in resistance of the "charging" electrode. Apparently the H does have some effect on the glass.

These experiments suffer in that the catholyte remains constant in composition at about Na₂S₅. In an actual running cell where the amount of ionic sulfide becomes very small in the highly charged state, more the added impurity might precipitate out or have a higher activity.

Work on actual running cells shows that Mg impurity does affect the glass resistance. Figure 10 shows the resistances of several 1000 fiber, 0.5 ampere-hour cells in which the cathode foils have various amounts of Mg as alloying agent. The cell using a foil of 5005 Al (.5-1.1% Mg) shows a steadily increasing resistance. A cell in which only a small piece of 5005 Al is placed shows a small rise in resistance, whereas the cell made from 1145 alloy Al (no Mg) shows no resistance increase with time. The resistance increase is attributed to an increase in glass resistance. A possible mechanism is that Mg from the foil gets into or on the glass structure as Mg⁺⁺ and causes strains. A confirmation of this effect is shown in Figure 11. The change in resistance with time is shown for two cells which are identical except for a small piece of Mg-containing Al placed adjacent to the fibers in one of the cells. The effect of the Mg-containing Al foil is clear.

The effect of using undistilled "flowers of sulfur" was determined by comparing lifetimes of cells operating using commercial flowers of sulfur treated as follows:

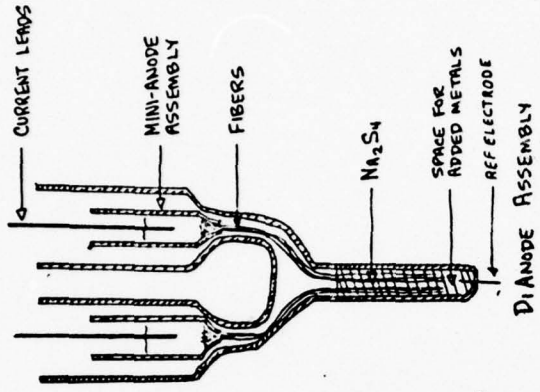
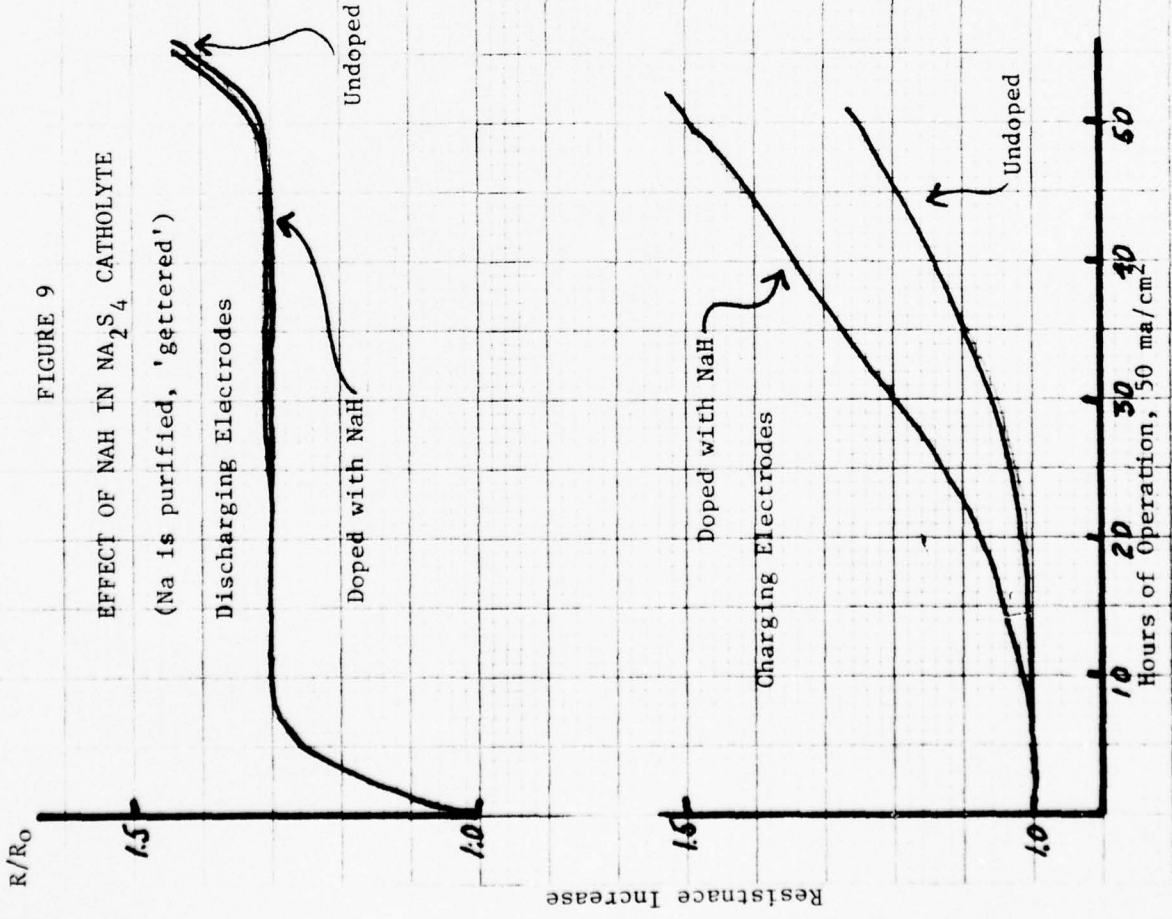

Cells DA-50
DA-55

FIGURE 10

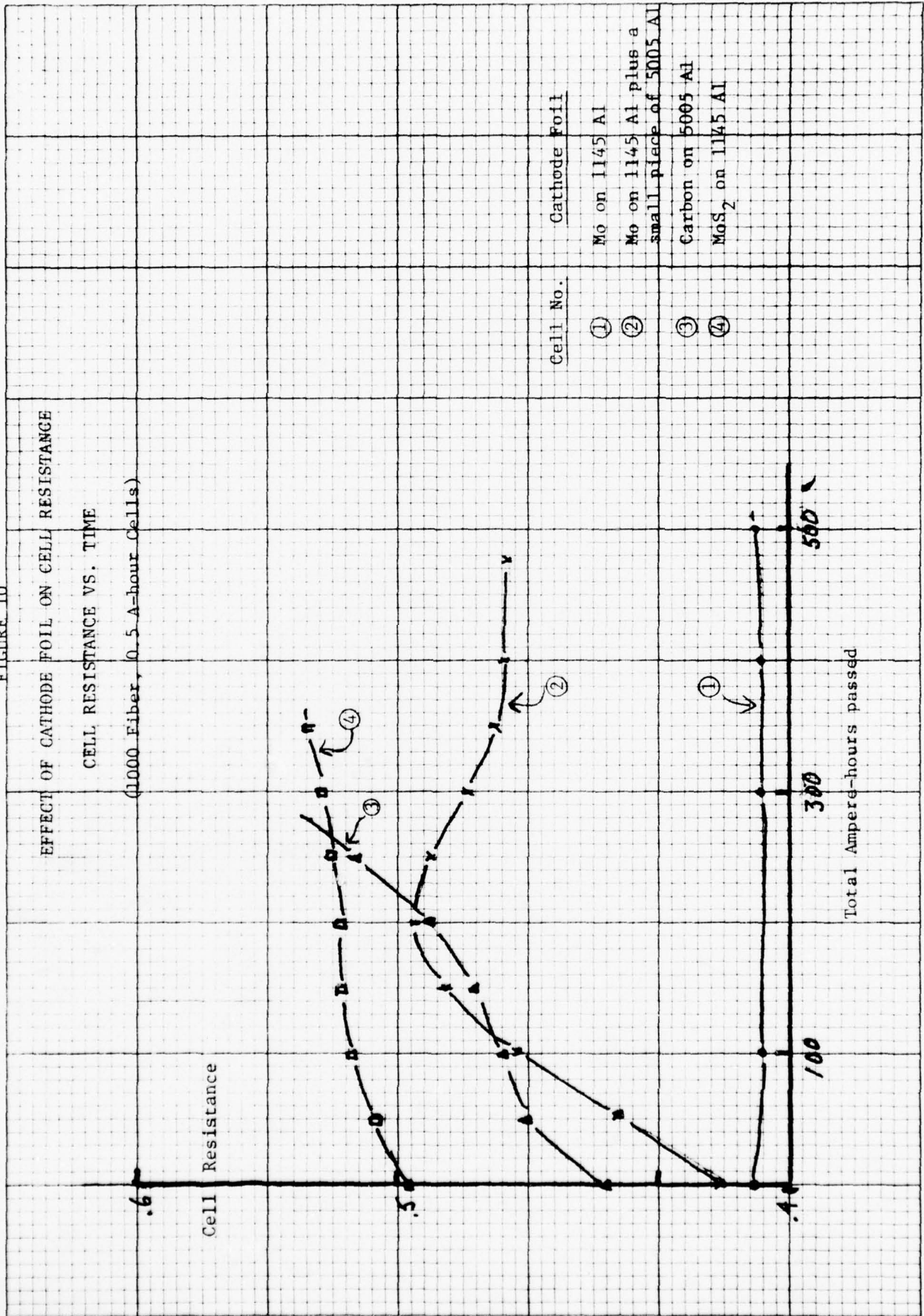
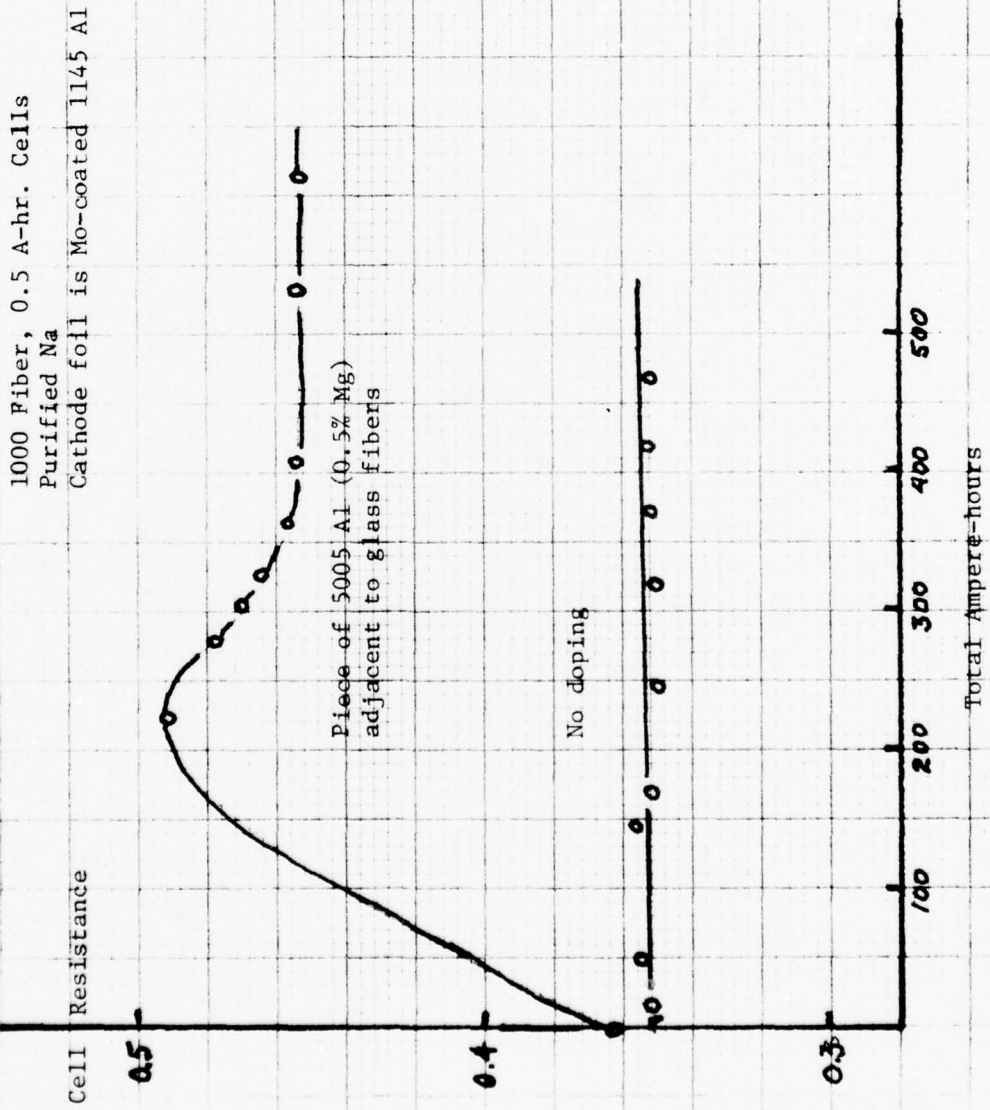

FIGURE 11

EFFECT OF 5005 Al ALLOY
CHANGE OF CELL RESISTANCE VS. TIME



- 1) Untreated
- 2) Filtered only
- 3) Filtered and bubbled with N₂
- 4) Distilled in the usual manner

The results indicated that using sulfur which had been only filtered does not drastically shorten cell life.

<u>Sulfur Treatment</u>	<u>Cell Life (1000 fiber, 0.5 A-hr.)</u>
No Treatment	<1 day
Filtered only	80 days
Distilled	58 to over 100 days

Addition of 1% lampblack to the sulfur (to simulate presence of CH_x and H impurities) did not appreciable shorten cell life.

The possibility of gross corrosion of the fibers by the sulfur-sulfide was tested by making cells of fibers having very thin walls. With the normal 10-15 μ wall thicknesses, cell life on deep charge-discharge cycling of the 1000 fiber, 0.5 a-hr. cells was 80-120 days. Some cells were built using fibers with 6 μ and 3 μ walls, keeping the fiber outer diameter at about 70 μ . These fibers were fairly delicate because of the combination of thin wall and relatively large diameter. The results shown indicate that the 3 μ wall is too delicate to assemble into a cell, and the 6 μ wall fibers have lifetimes as long as fibers twice as thick. In fact, the 6 μ wall fiber cell had the longest life of any cell to that date.

<u>Cell Fiber Size</u>	<u>Fiber Wall</u>	<u>Cell Life</u>
70 x 64	3 μ	- Broke during assembly
70 x 64	3 μ	- 6 days
70 x 58	6 μ	- Broke during assembly
70 x 58	6 μ	- 19 days
70 x 58	6 μ	- 26 days
70 x 58	6 μ	- 155 days

Electron microscopy studies of the surfaces of fibers held for 2 weeks at 300°C in Na₂S₄ showed no roughness or surface corrosion.

3. Minimizing Weakening of the Fibers at the Tubesheet

During fusion of the tubesheet the fibers become weakened or brittle at the point where they emerge from the tubesheet. They remain strong elsewhere. The causes of this weakening have been investigated and attempts to minimize this weakening made.

Fibers held at 400°C for up to 3 hours in a vacuum are not substantially weakened over the untreated fiber. The fibers are weakened if fine particles of the tubesheet glass (1.1% H₂O) are dusted on the fibers and the fibers then exposed to tubesheet curing conditions (taken to 150°C, treated with BCl₃ vapors, then taken to 400°C in a vacuum for 1-1/2 hours). The results from two separate experiments are shown:

<u>Fibers</u>	<u>Ave. Tensile</u>	<u>Range of Tensile</u>	<u>No. Samples</u>
Unheated	83,000 psi	--	--
Heated, but no "fines"	68,000 psi	--	--
"Fines" and heated	50,000	38 - 62,000	10
"Fines" and heated	35,000	27 - 39,000	7

The effect of the temperature of fusion and its role in the weakening was examined. Dabs of tubesheet paste were placed on individual fibers and the fiber-tubesheet material combination was subjected to curing temperatures in a vacuum. The individual fibers were then tested for tensile strength on an Instron Tensile tester. The fibers almost invariably broke at the interface of the tubesheet material at the higher temperatures. Figure 12 summarizes the results for both tubesheet materials of interest (95-1/2 B₂O₃ - 4-1/2 Na₂O and 94% B₂O₃ - 6% Na₂O). It also shows the scatter of test results. Obviously, for both kinds of tubesheet material, the weakening is a strong function of the temperature. The 95-1/2/4-1/2 tubesheet material is normally fused about 390°C and the 94/6 material is normally fused about 405°C. From the strength standpoint, it is better to use the 95-1/2/4-1/2.

SQUARE 10 X 10 TO THE INCH AS 0006 01
ESPIRATI & FAPER, BIOLOGICAL CONJUGATES CORPORATION, Buffalo, New York
Products U.S.A.

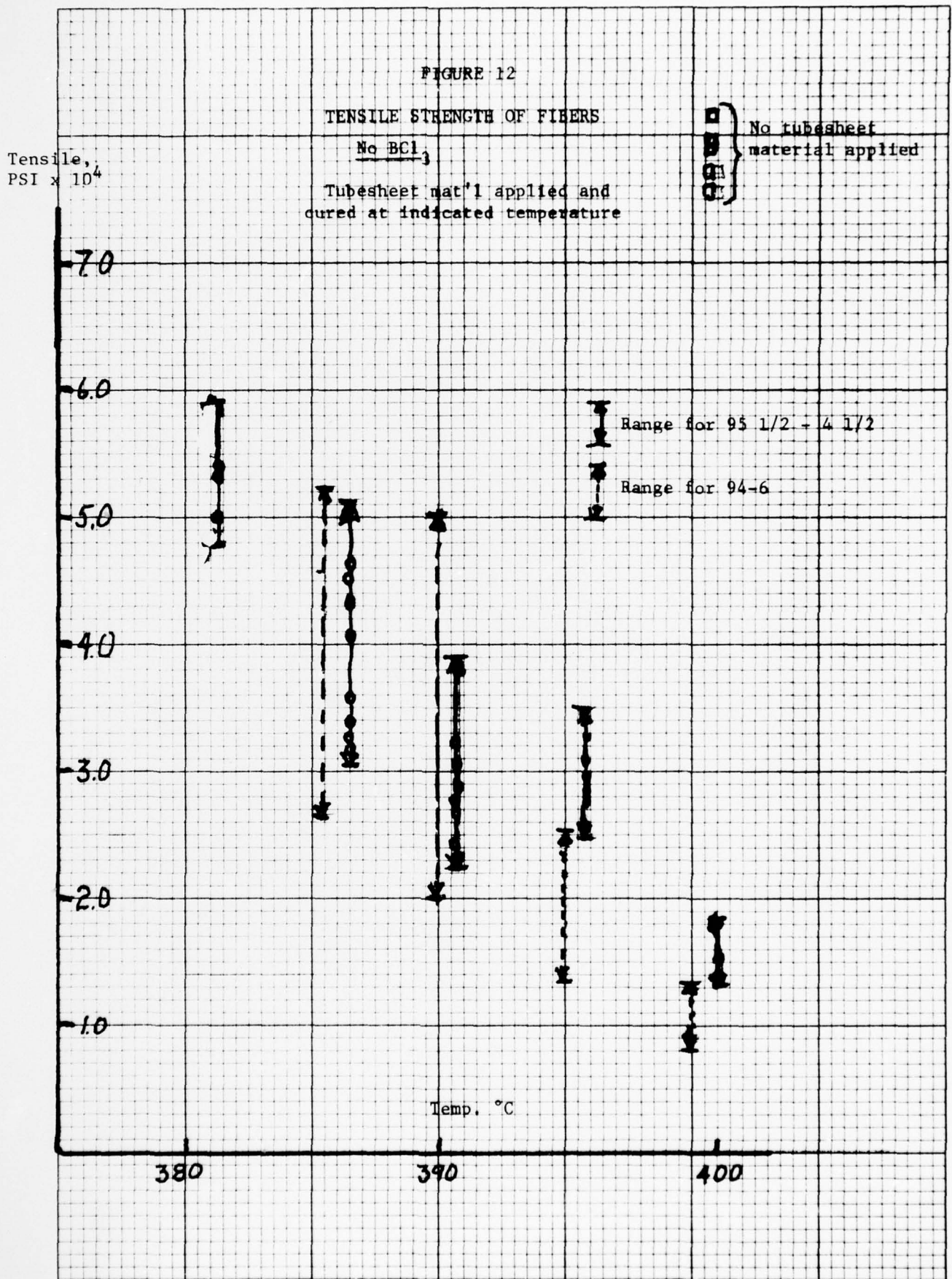

If the fibers and tubesheet material are treated with BCl_3 before fusion, an improvement is seen in the final strength. Figure 13 shows the average values of tensile obtained for both systems with and without the BCl_3 treatment. Although final strengths are improved, they are still pretty low. The causes of the weakening or embrittlement are not known. The moisture content of the tubesheet or the fluxing of the tubesheet glass on the fiber glass could be causing the embrittlement. The action of the BCl_3 would be to remove surface moisture from the tubesheet glass. Another cause could be the rigidity of the fused tubesheet, giving a notch-type stress concentration on the fiber at its juncture with the tubesheet. When BCl_3 is used, a somewhat porous surface layer is formed on the tubesheet which can partially absorb some of the fiber deformation before there is bending at the solidly fused layer.

One of the obvious remedies is to try to fuse the tubesheet at a lower temperature. Instead of 1-1/2 hours at 393°C or 405°C for the 95-1/2 - 4-1/2 or 94-6 tubesheet material, resp., fusion temperatures of 380°C for 4 hours or 375°C for 6 hours seem to work for the 95-1/2 - 4-1/2 material giving fibers that are not as brittle at the tube sheet.

II. Testing of Cells and Scaling up

The general procedure in the developmental effort is to run actual multi-fiber cells, analyze the failure modes and mechanisms, try to remove the failure causes, and then test the changes in new cells.

A number of different sizes of multi-fiber cells have been used. They range from 1000 fibers (0.5 ampere-hour) to 15,000 fibers (40 ampere-hour). Figure 14 is a picture of a 1000 fiber and a 3,000 fiber, 6 ampere-hour cell. The smaller cell is usually used to test variations in material or operating conditions and then the results are incorporated in the 6 A-hr. or larger cells.

The operational characteristics of the multi-fiber cells are similar whether 1000 or 15,000 fibers. This is because the electrode-electrode spacings within the foil wrap are the same and catholyte distributions from foil to foil are the same in large or small multi-fiber cells.

Maximum lifetimes of operating cells to date are given below:

	<u>Shallow Cycling</u>	<u>Deep Cycling</u>	<u>Total Deep Cycles</u>
1000 Fiber Cells (0.5 A-hr)	218 ⁺ days	92 ⁺ days	2310 ⁺
3000 Fiber Cells (6 A-hr)	97 days	28 days	90
15,000 Fiber Cells (40 A-hr)	~14 days	~14 days	6

FIGURE 13

LOSS OF FIBER STRENGTH AT TUBESHEET DURING TUBESHEET FUSION

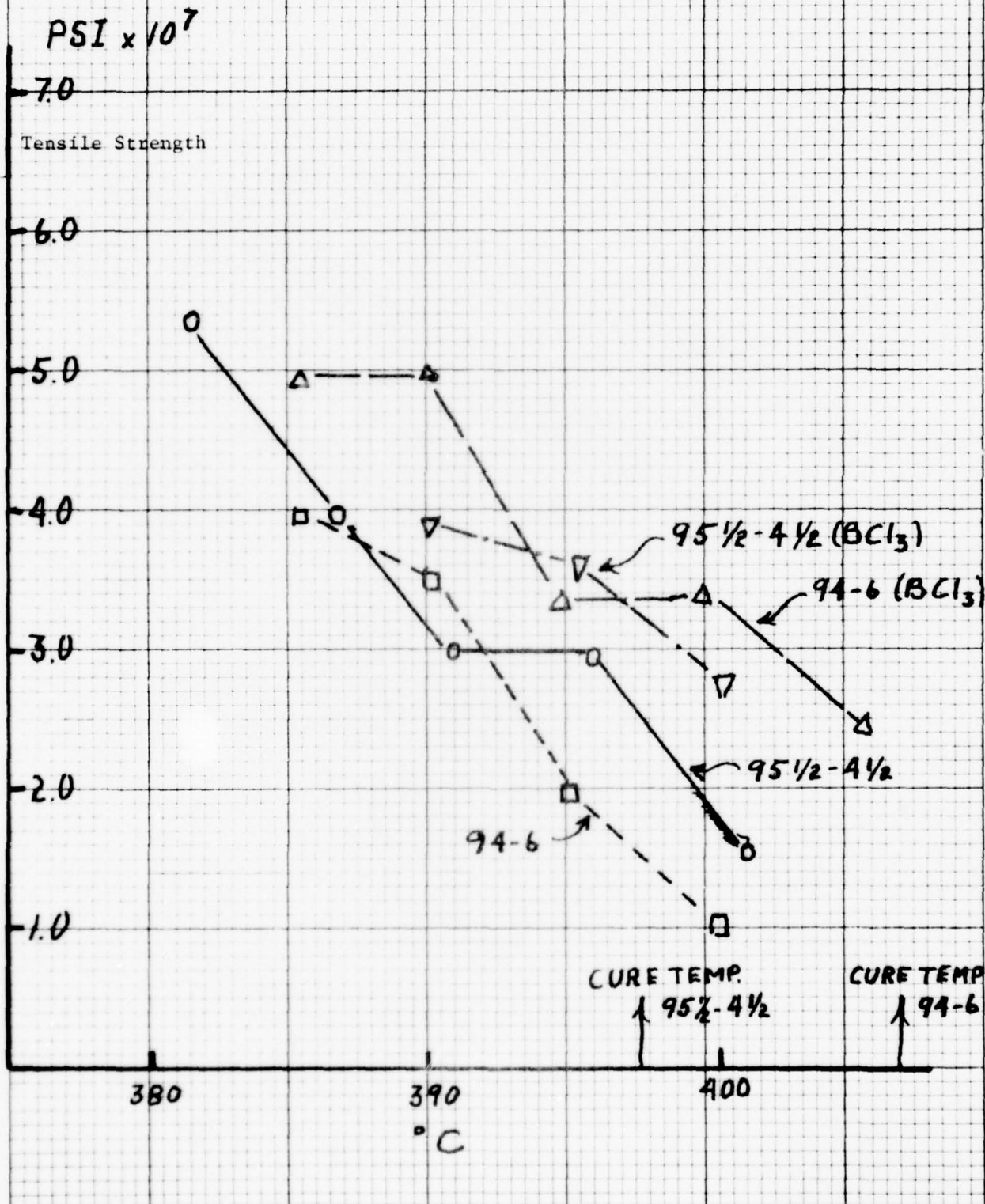

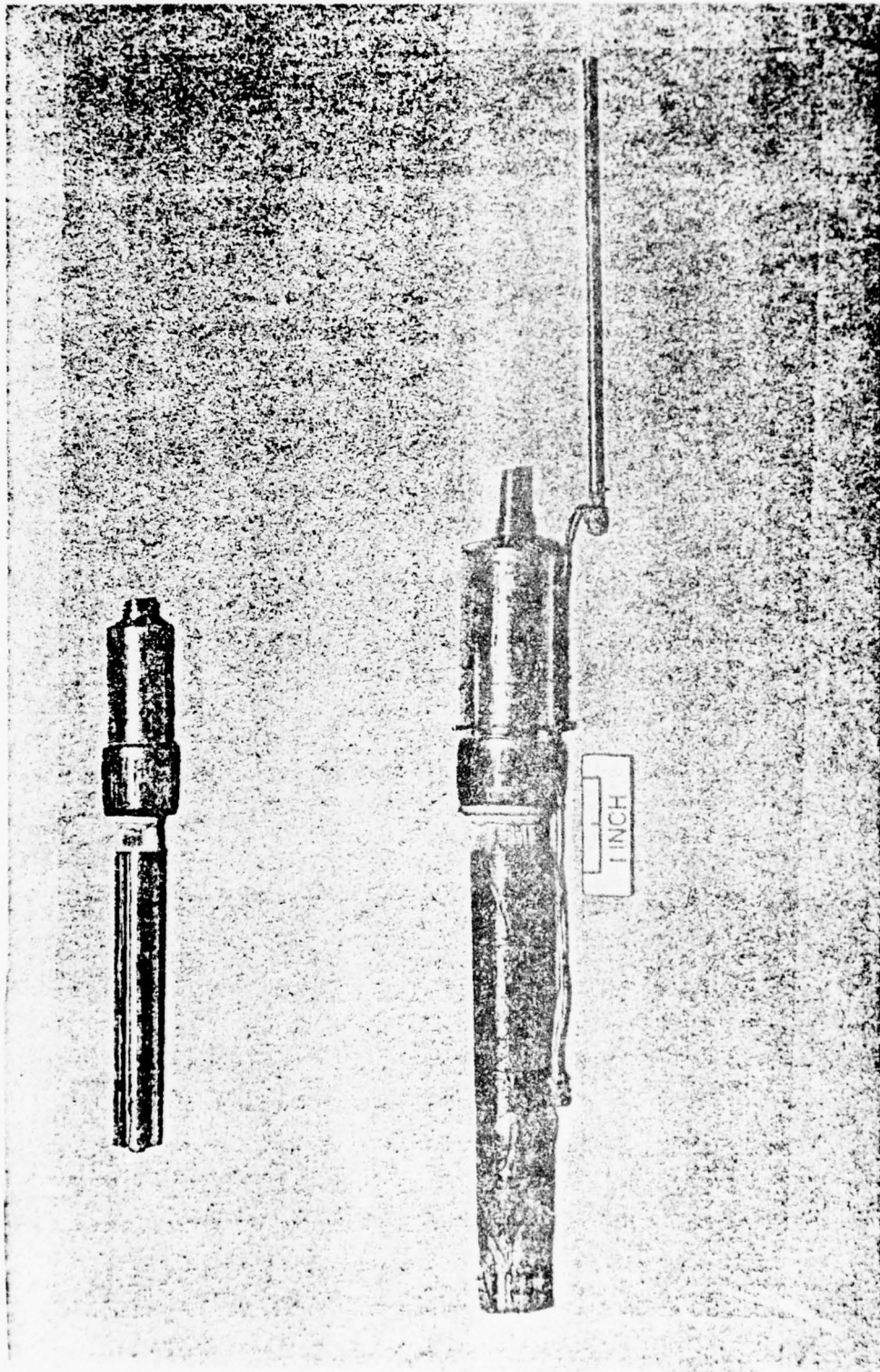

Typical Experimental Cells

TABLE I

6 A-HR. CELLS

Cell No.	Fibers, μ	Wall, μ	Depth	Current, A	Life, Days	Leak Rate	Notes
184	50 x 90	20	11%	.27	78	0	- Constant resist., 2 phase region, violent failure below tubesheet.
185	50 x 90	20	80%	1.0	8	20	- 12 cycles, 7.5 hr. rate, failure under tubesheet.
186	50 x 90	20	76%	1.5	8	24	- 7-1/2 cycles, 4.8 hr. rate, ran out of Na.
189	50 x 90	20	--	1.0	6	20	- Weak fibers, ran out of Na?
190	50 x 90	20	50%	0.6	8	20	- 6 hr. rate, low capacity. Sudden high resistance.
TK-38	40 x 90	25	10%	.24	60	0	- Sudden short to failure, tubesheet 7123, cured at 374°C.
TK-39	40 x 90	25	10%	.24	55	16	-
TK-49	40 x 90	25	12-24%	.3-.6	18	0	- Fibers broken at foil top; tubesheet 96/4, cured 386°C.
TK-50	40 x 90	25	12%	.3	13	7	- As above; in sulfur region.
TK-52	40 x 70	15	10%	.23	14	0	- Fiber failure; tubesheet 7123, cured 374°C.
TK-55	40 x 70	15	10%	.23	10	2	- Same as above, .004" spacer.
TK-54	40 x 70	15	13%	.32	30	1	- 156 cycles, failure below tubesheet, .005" spacer.
TK-60	50 x 90	20	--	--	2	12	- Short near bottom of fiber.
TK-62	50 x 90	20	15%	.35	17	2	- Sulfur region, failure under tubesheet.
TK-63	50 x 90	20	8%	.22	77	6	- Sulfur region, out of Na on 34th day, recharge some back, but high resist. Tubesheet 7123.
TK-64	50 x 90	20	20-25%	.5-.6	38 + 12	0	- Shorted and recovered, Na ₂ O added to Na, 7123 T.S.
TK-69	40 x 90	25	25%	.6	19	0	- Fiber failure: Use dry 7123 fines in T.S., Na ₂ O in Na.
TK-68	40 x 90	25	16%	.4	20	4	- Same as above.
TK-70	40 x 90	25	25%	.6	11	16	- Fiber failure, Ca-free Na, good T.S.
TK-71	40 x 90	25	18%	.45	46	6	- Failure under tubesheet, Ca-free Na.
TK-72	40 x 90	25	85%	.6	4	6	- 3 cycles, Ca-free Na. Possibly bad connection.
TK-73	40 x 90	25	80%	.8	4	18	- 3 cycles, probable short. 7123 T.S. fused 374°C.
TK-74	50 x 90	20	36%	.9	16	12	- Fiber failure, 1 and 2 phase sulfur, T.S. fused 374°C.
TK-75	50 x 90	20	28%	.7	8	6	- Failure under tubesheet. Ca-free Na, 7123 T.S.

TABLE I (CONTINUED)

Cell No.	Fibers, μ	Wall, μ	Depth	Current, A	Life, Days	Leak Rate	Notes
TK-78	50 x 90	20	40%	1.0	8	6	- Fiber failure, Ca-free Na, 7123 tubesheet.
TK-82	40 x 80	20	--	.5	1	32	- Shorting somewhere.
TK-85	50 x 90	20	85%	1.0	23	0	- 40 cycles to Na ₂ S ₃ 7, 6 hour rate.
TK-86	50 x 90	20	85%	1.0	20	8	- Probable fiber failure, air leak into cell (?)
TK-87	50 x 90	20	50%	1.2	12	3	- 26 cycles, probable tubesheet failure cell resist. constant. Probable air leak into cell
TK-88	50 x 90	20	>80%	1.8	26	1.3	- Failed under tubesheet. Resist. constant. Weak fibers.
TK-90	50 x 90	20	75%	1.0	17	0	- 130 cycles. Failed under T.S., cell resist. increased 30% in 2 weeks.
TK-99	50 x 90	20	>75%	2.-3.	12	4	- 26 cycles. Fiber failure, air leak (?)
TK-100	50 x 90	20	80%	2.0	11	1	- Hole in Al cup. Air leak (?)
TK-108	40 x 80	20	>75%	1.6	9	8	- 33 cycles. Failed under T.S. Resistance increased.
TK-109	50 x 80	15	>80%	2.0	12	2	- 35 cycles. Fiber failure. T.S. OK.
TK-111	50 x 80	15	30%	1.8	14.5	14	- Al ₂ O in Na. Resistance increased 100%. Air leak (?)
TK-113	50 x 90	20	>90%	1.2	4	0	- Tubesheet failure, resist. increased.
TK-115	50 x 90	20	>80%	.7	3	15	- 116 cycles, Mo-Al foil. High resistance. Failed at fiber ends. Na treated with Zr-Ti.
TK-116	50 x 90	20	60%	1.5	20	0	- After 3 days, ran 22 days at 10% depth. Na treated with Zr-Ti.
TK-117	50 x 90	20	10%	.23	24	0	- Fiber failure. Cell resist. increases.
TK-119	50 x 90	20	open circuit		31	3	- Mo-Al foil, low on Na, low capacity.
TK-121	45 x 80	17	>75%	2.0	7	8	- 7123 tubesheet, fused at 374°C.
TK-122	--	--	25%	.6	18	0	- Failure through T.S. 7123 cured at 383°C.
TK-124	50 x 70-80	10-15	>75%	1.5	16	0	- Fiber failure, 7123 T.S. cured at 384°C.
TK-147	50 x 80	15	40%	1.0	8	0	- Fiber failure, 7123 T.S. cured at 383°C. Fiber failure, 94-6 T.S. cured @ 390°C, air leak.

<u>Cell No.</u>	<u>Fibers, μ</u>	<u>Wall, μ</u>	<u>Depth</u>	<u>Cycle Time</u>	<u>Current A</u>	<u>Life, Days</u>	<u>Leak Rate</u>	<u>Remarks</u>
PTS-5-14	50 x 80	15	8%	4 hrs.	.25A	97	0	- Metal case, 2 phase region
17-1	50 x 80	15	70%	4 hrs.	2.1A	8		- Fiber failure, no oxide scavenger
18-1	50 x 80	15	70%	4 hrs.	2.0A	9		- Fiber failure, no oxide scavenger
18-4	50 x 80	15	70%	4 hrs.	2.0A	17		- Fiber failure, no oxide scavenger
20-6	50 x 80	15	>85%	4 hrs.	1.0	24		- Tubesheet fiber, deep cycling, scavenger added
20-5	50 x 80	15	>85%		1.3	25		- ? , deep cycling, scavenger added
PTS-5-117	50 x 80	15	20%		.6	28		- Metal case cell, failure mode (?)

TABLE II

0.5 AMPERE-HOUR CELLS

Cell	Tube Sheet	Cathode	Depth	Life		Failure Mode	Remarks
				Days	A-days		
PS-13	94	MoAl	>95%	19	19	-at tube sheet	
PS-23	94	MoAl	80%	11	8	-at tube sheet	
PS-20	95-1/2	MoAl		Used in cooling experiments			
PS-16	95-1/2	MoAl	>90%	10	10	-at tube sheet	
PS-15	95-1/2	MoAl	>90%	9	9	-at tube sheet	
PS-24	95-1/2	MoAl	>90%	22	22	-at tube sheet	
PS-18	95-1/2	MoAl	>90%	18	18	-at tube sheet	
PS-21	95-1/2	CMoAl	90%	26	25	-fiber failure	
PS-27	95-1/2	CMoAl	95%	29	28	--	
PS-22	95-1/2	CAI	--	20	15	-at tube sheet.	Took 2 weeks to reach normal cell resistance. T.S. cure at 405° instead of 397°C.
PS-25	94	MoAl	90%	47	43	-Al cup joint failure.	
PS-26	94	MoAl	>95%	14	14	-Fiber failure. High internal resistance.	
PS-29	94	CAI	--	9	2	-Ran out of Na. High resistance.	
PS-28	94	Al	--	--	--	-Tube sheet area. High resistance.	
PS-30	94	Al	--	32	--	-at tube sheet. Increasing resistance	
PS-31	94	CAI (Mg)	85%	15	12	-at tube sheet. Some resistance increase	
PS-32	94	MoS ₂ /Al	85%	20	16	-at tube sheet. Cured T.S. at 420°C	
PS-35	94	MoAl	89%	49	43	-failed in prolonged charge to 40 volts	
PS-34	94	MoAl	--	41	30	-at tube sheet. Decreasing resistance for 6 days.	
PS-33	94	CAI	--	36		cycle 3x at 360°C. Resist. drops to near normal.	
PS-36	94	MoAl	>95%	27	27	-constant resistance	
PS-38	94	CAI	--	40	19	-at tube sheet. Slowly decreasing resistance	
PS-37	94	MoAl	>95%	20	19	-at tube sheet. Cure T.S. at 420°C.	
PS-39	94	CrAl	--	1	--	-at tube sheet.	
PS-40	94	MoAl	100%	75	70	- 316 S.S. insert	
PS-44	94	MoAl	90%	23	20	-low K in Na	
PS-45	94	MoAl		10		-impure sulfur	
PS-42	94	CAI	--	11	--	-fiber failure. High temp. to condition foil didn't work.	
PS-50	94	MoAl	--	19	--	-air leak	
PS-49	94	MoAl	55%	87	48	-T.S. cured at 420°C	

TABLE II

Cell	Tube Sheet	Cathode	Depth	Life		Failure Mode	Remarks
				Days	A-days		
PS-51	94	MoAl	82%	>36	>28		1% lampblock to sulfur. Rapid start.
PS-47	94	MoAl	60%	34	20	-tubesheet area	
PS-41	94	MoAl	100%	19	21	-tubesheet area. 6 μ wall fiber	
PS-43	94	MoAl	12%	185	75	-last elect. contact 37th day. Partially recovered.	
PS-46	94	MoAl	95	6	11	-6 μ wall fiber, massive failure under tubesheet	
PS-54	94	MoAl	6	>213	>173	-fiber failure. 3 μ wall fiber	
PS-53	94	MoAl	29	>218	>95	-high rate (.8 amp), shallow, 4 min. cycle.	
PS-52	94	MoAl	78	103	83	-shallow, 1 and 2 phase region	
PS-56	94	MoAl	95	26	29	-possible fiber failure	
PS-57	94	MoAl	91	59	57	-tubesheet area. More Zr-Ti added to Na, 6 μ wall	
PS-55	94	MoAl	73	121	94	-fiber failure.	{ -no BCl ₃ treatment. Resistance constant
PS-59	94	MoAl	90	15	12	-fiber failure. Crude filtered sulfur.	-more Zr-Ti added to Na. Failure in control
PS-58	94	MoAl	86	>24	>19	-fiber failure. Crude filtered sulfur.	
PS-60	94	MoAl	80	80	82	-Volt control, fiber failure?	

NOTE: Most PS cells cycled at 1/2 hour rate for charge and discharge.

Single Fiber Cells

- 0.95 MoAl 30-35 ma/cm², cycling at 6 column vols/cycle in Na₂S₄.
 Lifetime = >47 days, >33.84 A hr/cm², >11,500 cycles.

- 95 MoAl same conditions as above.

Lifetime = >45 days.

<u>Cell</u>	<u>Tubesheet</u>	<u>Cathode</u>	<u>Depth</u>	<u>Life</u>		<u>Failure Mode</u>	<u>Remarks</u>
				<u>Days</u>	<u>A-Days</u>		
PS-64	94	50 Å Mo/Al	10%	45	~2		High resist. 50 Å Mo NG
PS-65	94	c/50 Å Mo/Al	20%	27	~2		Somewhat lower R than PS-64
PS-62	94	c/Al 1145	~7%	33			High metal R, slowly dropped
AG-6	94	Mo/Al	90%	>46	>45		1.0 Amp, Ba-titrate, added getter
AG-7	94	Mo/Al	75%	37	30		0.8 Amps, No Ba titrate, added getter
AG-15	94	Mo/Al	75%	>92	>90		Large excess of scavenger
AG-17	94	Mo/Al	~80%	47	47	Massively under TS 1.0 Amp	
AG-22	94	Mo/Al	>90%	37	37	Massively under TS 1.0 Amp	
AG-30	94	Mo/Al	>90%	21	20	Massively under TS 1.0 Amp.	Large excess of scavenger

The 218 plus day operation is at 30% depth of discharge in both the single and two phase region on cycles of 1/2 hour charge and 1/2 hour discharge. The 92 plus days of operation is essentially 100% of capacity ($\text{Na}_2\text{S}_{3.5}$ to Na_2S_{20}) on 1 hour total cycles. This is about 12 times the design current density. Table I and Table II show lifetimes and operating conditions of some selected cells.

Failure modes have been associated with both the tubesheet and with fiber breakage. Before removal of the calcium and the oxides from the sodium, failure was predominantly fiber breakage. After removal of the calcium and oxides from the sodium as described in the previous section, failure appeared to be associated with the tubesheet. Apparently, the very clean sodium wetted and spread on the tubesheet surface much more readily than the impure sodium. The sodium penetrated pores in tubesheet which had not been completely fused, reacted with sulfur just under the tubesheet, and the heat evolved burned off fibers at the fiber-tubesheet juncture. Higher temperatures of fusion or longer times of fusion for the tubesheet lessened this problem.

At present, the limit on cell lifetimes seems again to be corrosion of the fibers by sodium oxide. Although the sodium charged into the cell is oxide-free, water from the glass parts of the cell migrates into the sodium during cell operation and forms oxide. To remove this cause of failure, cells are now being run with an excess of Zr-Ti alloy as an oxide scavenger in the molten sodium.

Charge-discharge cycling of the cells is done either by timed cycles or by switching at pre-set voltages. The cells are discharged through a fixed resistor and charged at a constant voltage.

Current density through the glass, i.e., operating rate of the cell, seems to have no effect on the lifetime of the cell so long as the voltage drop across the glass is not excessive (~ 3.5 volts?). Most of the 0.5 ampere-hour cells were run at 15-20 ma per cm^2 of glass surface instead of the 2 ma per cm^2 design rate. The 6 ampere-hour cells were run at rates varying from 2 hour (3 amperes) to 8 hour (.75 amperes). Lifetimes are a function of depth of discharge rather than rate of discharge. However, when over 3.5 volts were placed across cells using 10 wall fibers, cell lifetime was usually terminated within a day.

Cells cycled at deep depths of discharge and charge lasted shorter times than those put on shallow cycling. This is true whether the shallow cycling was done with the catholyte in the one phase (sulfide) region, the two phase (sulfur and sulfide) region, or across both regions. Possible reasons for the shorter lives on deep cycling could be:

- 1) Formation of solid Na_2S_x at the deep discharge end
- 2) Increased activity of harmful inorganic impurities in the catholyte as the ionic component of the catholyte decreases at the high charge end of the cycle

- 3) Increased concentration of sodium oxides in the glass fiber as more "column volumes" of sodium are discharged.

Tests are underway to test these hypotheses.

Switching from charge to discharge and vice versa does not cause shortened lifetimes of the cells. One cell (PS-54) has been operating over 217 days to 6% depth of discharge on a 4 minute cycle. It is still operating after 77,400 cycles even though the current density through the glass is about 8 times the design current.

Since current density, total current, and charge-discharge cycling have no real effect on the lifetime of the cell, the only good lifetime test is actually running cells on deep cycles.

Tables I and II do not record the effect of the moisture content of the tubesheet. Near the end of the Contract Period it became apparent that cells made with tubesheet material having moisture contents of over 0.25% had lifetimes limited to about 24-30 days. The longer lived cells in the tables had tubesheets with moisture contents of 0.12% or less. This parameter may be a very important one with regard to the breakage of fibers at the fiber-tubesheet juncture on extended cell operation.

In an earlier section, the change in cathode foil from carbon on 5005 aluminum to an evaporated coat of molybdenum on 1145 aluminum was mentioned. The different foil had a real effect on cell characteristics. This is shown in Figure 14. The cell resistance when the carbon on 5005 Al was used stayed quite constant until the catholyte became concentrated in sulfur in the highly charged state. Using 1000 Å of Mo on 1145 Al, the cell resistance increased markedly during the charge cycle. The extent of the increase depended on the thickness and the surface treatment of the foil, as shown in Figure 15. An adequate foil is made by electron beam evaporating 350-500 Å of Molybdenum on a clean surface. The resistance change during charge due to the foil surface is less than 10% of the cell resistance.

Scaling up the cell in size increases the diameter of the cell by increasing the number of fibers. The larger cells have shorter lifetimes than the smaller cells. A number of 15,000 fiber, 40 ampere-hour cells were made and two were run at deep charge-discharge cycling. The cell resistance and C-D characteristics during the cells lifetimes were exactly as predicted based on the data from the smaller cells. Maximum lifetimes of the cells were about 2 weeks. The probably causes of the shorter lifetimes for larger cells are:

1. The "art" of making a good tubesheet of the larger size must be developed
2. Handling the larger cells in an unfinished state puts more strain on the fibers and leads to fiber breakage.

FIGURE 14
CATHODE FOIL EFFECT ON CELL RESISTANCE DURING A CHARGE-DISCHARGE CYCLE

3000 Fiber, 6 A-hour Cells

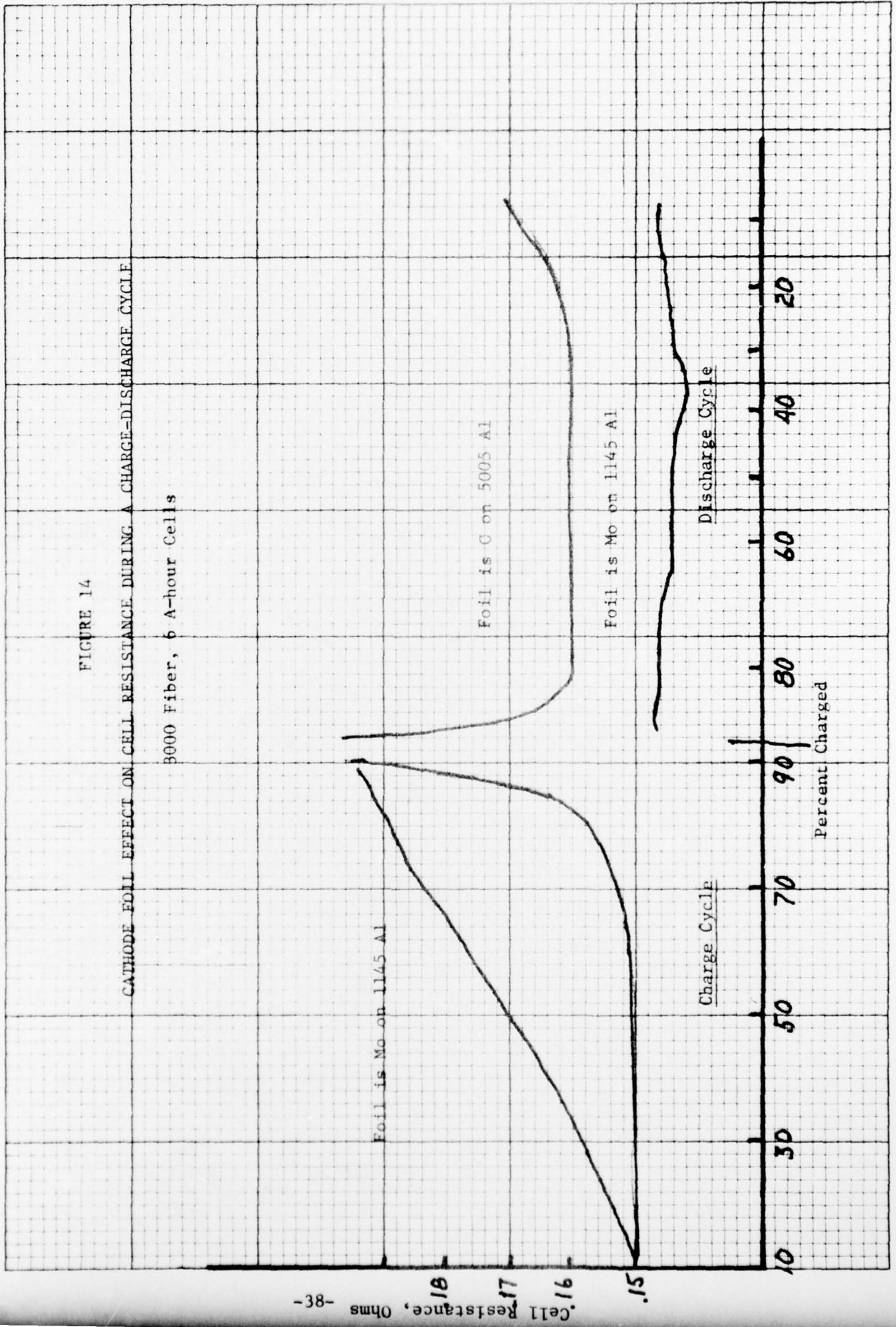
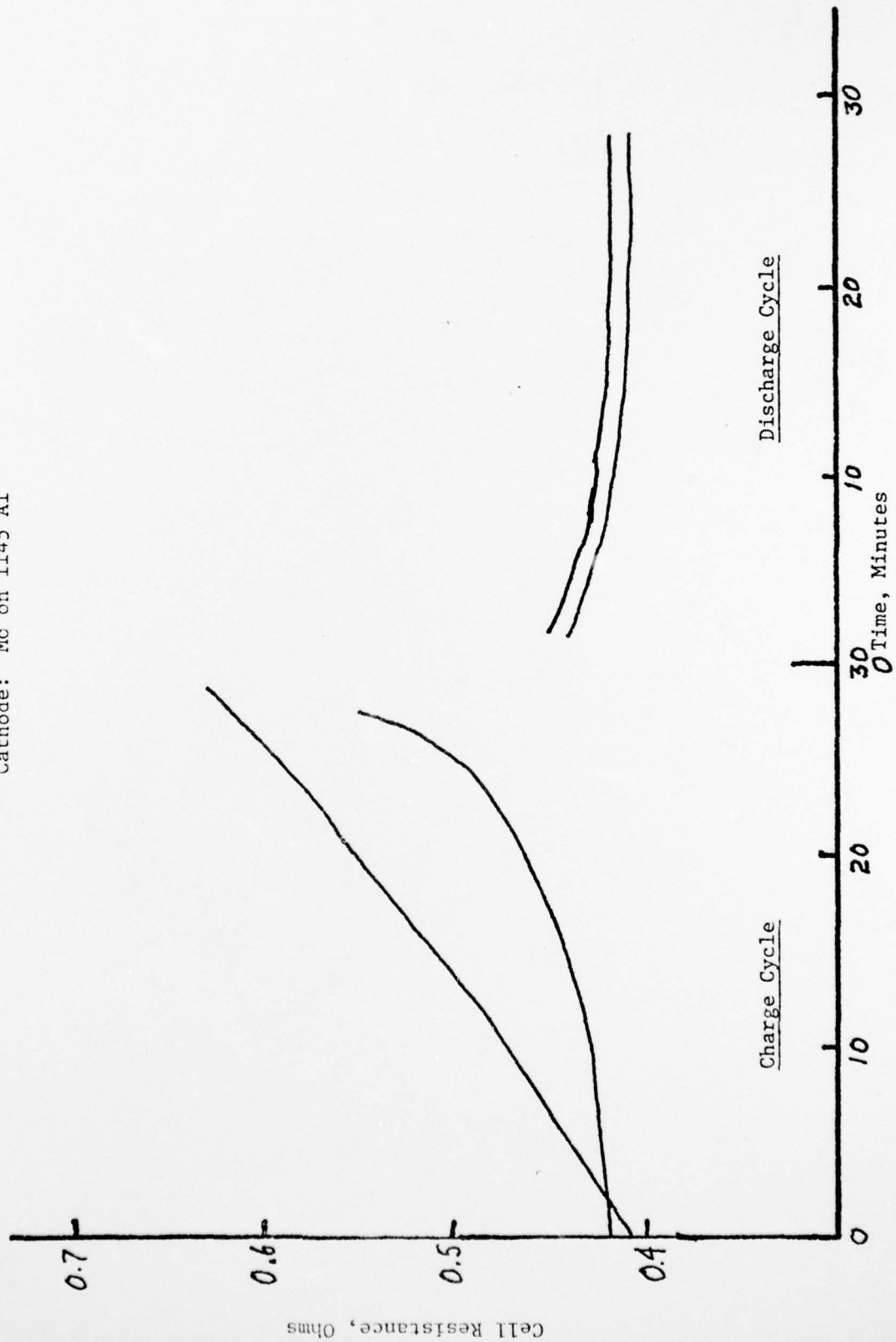

FIGURE 15

COMPARISON OF "IDENTICAL" CELLS' RESISTANCES DURING A CHARGE-DISCHARGE CYCLE

1000 Fiber, 0.5 A-hour Cells
Cathode: Mc on 1145 Al



Both probably causes can be corrected with practice and experience.

Both of the operating 40 ampere-hour cells failed by massive failure at the tubesheet, causing the pyrex glass envelopes to shatter. It was decided to concentrate on improving the life of the 6 A-hour cell before again scaling up to larger cells. Other than the problem of "technique" of making the larger tubesheet, no barriers seem to exist to scale-up.

III. Thermal Cycling the Cell

Only a minor effort was put on determining those conditions or constructions which would allow thermal cycling of the cells from 300°C to room temperature. It was felt that an extensive effort towards this goal should take place after the cell has been successfully scaled up to the 40 ampere-hour size.

In the past it had been determined that one of the necessary features was to control the solidification and remelting of the sodium. When sodium melts, it expands about 10%. If sodium in the fibers melts before the Na in the reservoir, it expands and breaks the fibers. Therefore, if the cell is to be reheated through the melting of sodium, the sodium in the anode cup reservoir must be melted first -- followed by melting the sodium in the fibers.

The first trials of cooling the cell during this period were cooling to 300°C to a temperature where the reactants were still liquid and reheating to 300°C. Two 0.5 ampere hour 1000 fiber cells, in the fully charged condition, were cooled from 300°C to 120°C. At this temperature the sulfur catholyte and the sodium anolyte are both still liquid. The cells were reheated to 300°C, and then the temperature cycling was repeated several times, leaving the cells at 120°C for as long as several hours. When the cells were reheated to 300°C, they discharged and charged normally.

One of the cells was cooled to room temperature and reheated without the special precautions concerning the sodium remelting. No output voltage was obtained when the cell was reheated.

In addition to the Na remelting, there is probably a problem with the solidification of the sulfur-sulfide catholyte. From its solidification temperature down to room temperature, the cell bundle consists of adjacent thin layers of aluminum foil and solid sulfur-sulfide, with fine hollow fibers embedded in it. All three elements have different expansion coefficients and the strains may break the fibers. A special design has been suggested that may allow cooling of the catholyte. This design would provide extra space between the anode cup and the cell case so that if the cell were inverted while the catholyte is still molten, the catholyte would flow into the extra space reservoir and solidify there.

Both probably causes can be corrected with practice and experience.

Both of the operating 40 ampere-hour cells failed by massive failure at the tubesheet, causing the pyrex glass envelopes to shatter. It was decided to concentrate on improving the life of the 6 A-hour cell before again scaling up to larger cells. Other than the problem of "technique" of making the larger tubesheet, no barriers seem to exist to scale-up.

III. Thermal Cycling the Cell

Only a minor effort was put on determining those conditions or constructions which would allow thermal cycling of the cells from 300°C to room temperature. It was felt that an extensive effort towards this goal should take place after the cell has been successfully scaled up to the 40 ampere-hour size.

In the past it had been determined that one of the necessary features was to control the solidification and remelting of the sodium. When sodium melts, it expands about 10%. If sodium in the fibers melts before the Na in the reservoir, it expands and breaks the fibers. Therefore, if the cell is to be reheated through the melting of sodium, the sodium in the anode cup reservoir must be melted first -- followed by melting the sodium in the fibers.

The first trials of cooling the cell during this period were cooling to 300°C to a temperature where the reactants were still liquid and reheating to 300°C. Two 0.5 ampere hour 1000 fiber cells, in the fully charged condition, were cooled from 300°C to 120°C. At this temperature the sulfur catholyte and the sodium anolyte are both still liquid. The cells were reheated to 300°C, and then the temperature cycling was repeated several times, leaving the cells at 120°C for as long as several hours. When the cells were reheated to 300°C, they discharged and charged normally.

One of the cells was cooled to room temperature and reheated without the special precautions concerning the sodium remelting. No output voltage was obtained when the cell was reheated.

In addition to the Na remelting, there is probably a problem with the solidification of the sulfur-sulfide catholyte. From its solidification temperature down to room temperature, the cell bundle consists of adjacent thin layers of aluminum foil and solid sulfur-sulfide, with fine hollow fibers embedded in it. All three elements have different expansion coefficients and the strains may break the fibers. A special design has been suggested that may allow cooling of the catholyte. This design would provide extra space between the anode cup and the cell case so that if the cell were inverted while the catholyte is still molten, the catholyte would flow into the extra space reservoir and solidify there.

IV. Design and Construction of a Metal Case for the Cell

The sodium-sulfur cell must be constructed in such a manner that in case of cell failure, there is zero chance of the hot sodium or sulfur being released from the cell casing. Originally, an aluminum case had been envisioned for the cell. Early experiments showed that such a cylindrical case, with a diameter to wall thickness ratio of 40:1 would be structurally stable for at least one month at 300°C with a pressure difference of 1 atmosphere between the inside and the outside. Aluminum was chosen because of (1) its ease of formation into desired shapes, (2) its relatively low cost, and (3) its good electrical conductivity.

Unfortunately, aluminum alloys have very low tensile strength at elevated temperatures. If cell failure occurs by massive failure of the tubesheet, localized temperatures higher than 700-750°C can be obtained from the direct reaction of sodium and sulfur. If the aluminum case reaches these temperatures, it may rupture. For this reason, work was directed at making a stainless steel case.

A test was made to determine the effect of 316 stainless steel on the operation of cell showed no effect in 75 days of high current operation (cell PS-40). A program was begun to design a 316 stainless steel case, use it to enclose a 6 ampere-hour cell, and operate the cell. The case was overdesigned in thickness to provide protection until actual failure analyses could define the strength needed.

Figure 16 shows the metal parts of the cell. The bottom of the anode cup assembly is dipped into molten tubesheet glass in order to put a 1/4" high sealing ring around the bottom open end. The cured cell bundle itself (fibers, foil, tubesheet assembly) is dropped into the cell body with the spindle emerging from the bottom. The ledge of the tubesheet rests on the built-in body ledge. The anode cup and top seal assembly is then placed on top and the whole assembly heated to seal the bottom of the anode cup to the tubesheet. As this seal is made the anode cup and top seal assembly drop about 1/2" and the cell top sits flush with the top of the cell body. A weld is then run around the cell top and the bottom spindle is welded to the cell body. The sodium and sulfur are introduced into the cell through the tubings used for the anode lead and the spindle of the fiber bundle.

Care must be taken during the welding processes so that heat induced distortions do not cause strains to be put on the fibers. Seven metal-cased cells were successfully assembled and started. One of these, PTS-5-14, operating on 0.25 amperes and 4 hour cycles (18% capacity), lasted 97 days -- a record lifetime to date for 6 ampere-hour cells.

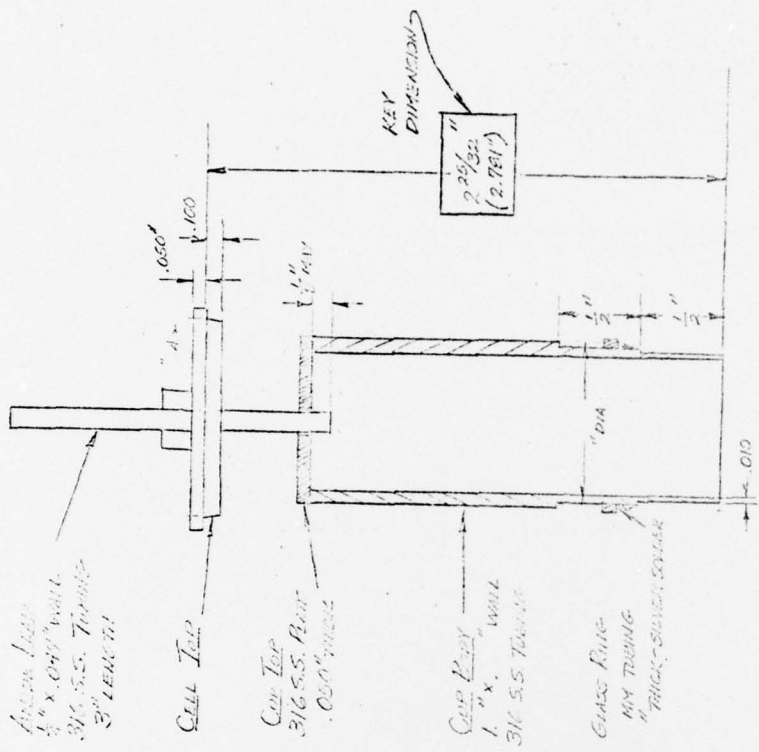

Anode Cup & Top Seal

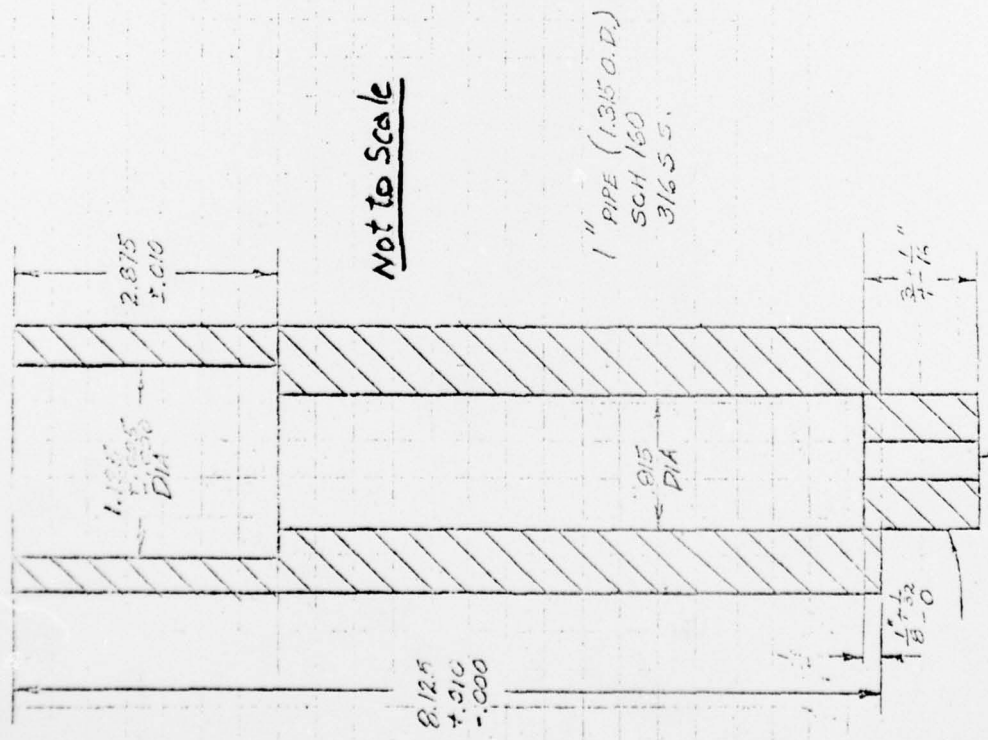

Not to Scale

Cell Body

Among the cell failures, one cell showed a very high heat release. The temperature apparently reached the point where the aluminum foil and some of the stainless steel anode cup melted and the aluminum probably reacted with excess sulfur. The cell body for any cell must be made thick enough to protect against this possible failure mode. Whether this requires a 0.20" wall or a 0.015" wall is not known.

V. Improve Fabrication Operations

1. Glass Fiber Spinning

The ability to spin hollow glass fibers, take-up the continuous tow, cut the fibers to size and assemble them such that they can be rolled into cells was greatly improved. Proper cooling of the molten glass as it emerges from the spinnerette is critical and much effort went into trying to control that cooling. At present, spinning 50 x 80 μ fibers, cutting them to length, setting them parallel at .031 cm center to center spacing and sealing the ends can be smoothly done. Because of the increased stability of spinning, relatively large diameter thin wall fibers (70 μ x 64 μ , 70 x 58 μ) can be reproducibly drawn.

A major improvement was the design and completion of an automatic sequence timer which automates the preparation of glass for spinning. The glass is melted, debubbled, and its temperature is lowered to the spinning temperature without technician attention. Other improvements in the fiber spinner include new softer lay-down belts for moving the glass fibers, new constant flow glue applicators, and new plug-in hot N₂ glass fiber cutters. These have been described in previous reports. As a result of the above improvements most of the glass fibers pulled are of excellent quality with few breaks and almost no double seals.

2. Tubesheet Material

a. Tubesheet Fines

The glass tubesheet used to hold the fibers together is made by fusion of a powder compact of low melting borate glass. Two different formulations have been used, B₂O₃:Na₂O ratios of 95-1/2:4-1/2 and 94:6. The powder compact is made by evaporating off the liquid (cumene) from a paste which is extruded on the fibers during cell assembly. In order to minimize shrinkage, it is important that the solids content of the paste be as high as possible. In order to have a high solids content, the tubesheet glass paste is made of a 50:50 mixture of fine glass particles (mostly less than 2 μ) and glass spheres (40-60 μ).

Preparation of the fine particles has been and is a continuing problem. The fine particles are made by grinding or ball-milling -325 mesh glass particles. In order to be useable these particles must be capable of being suspended in the liquid vehicle (cumene) used to make the paste. For good suspension the particles must be ground finely and must have a proper surface character. Grinding in the presence of 1 to 1-1/2% (by weight of the glass) hexadecylamine assists the grinding and also leaves the particles with a treated surface that will suspend in the cumene.

The grinding is done either by ball milling for 7-10 days at 90°C or by milling in a Sweco Vibra-Mill for 48 hours at 90°C. Neither system gives reproducible results. A study described in detail in the Semi-annual Technical Report for July, 1976 suggests that if the particles are ground to less than 2 microns, the size and size distribution is adequate. But the surface condition of the fine particles is not always adequate. Factors affecting this surface (and probably the grinding) include moisture content of the glass, humidity in the grinding chamber temperature, and grinding aid. The temperature must be such that the vapor pressure of the hexadecylamine grinding aid is high enough to coat the freshly exposed particle surfaces to prevent re-agglomeration. The water and the amine compete for the fresh surface and the best conditions for "good" fines are not yet defined.

b. Tubesheet Spheres

The 40-60 μ glass spheres used in the tubesheet paste are made by dropping 40-60 μ glass particles through a flame. It is important to keep the water content of the tubesheet glass at a very low level. High moisture contents of the glass lead to more rapid failures of the cells. In order not to add water to the glass during the spheroidizing procedure, a CO + O₂ flame was used.

Because of the danger and expense of CO, alternate methods were tried. Unsuccessful methods included dropping the particles down heated tubes and trying to make the round particles directly from the melt.

Analyses of water contents of spheres indicate that the use of hydrocarbon flames instead of CO flames for spheroidizing does not add water to the glass. The following shows results of H₂O analyses.

<u>Sample</u>	<u>Bulk Water Content</u>
Particle Feed	.03 <u>±</u> .02%
CO-Made Spheres	.06%
C ₂ H ₂ -Made Spheres	.05%

The spheroidizing is now done rapidly and easily in an acetylene flame, and, surprisingly, the moisture content of the glass spheres is no higher than when carbon monoxide flames were used.

3. Sodium-Sulfur Fill Station

Assembling and filling sodium-sulfur cells on a large scale in inert atmosphere chambers does not seem feasible. A "filling station" was designed and built that should enable the filling of the metal-cased Na-S cell with purified molten sodium and molten sulfur without using inert atmosphere chambers. Figure 17 is a picture of the station. Figure 18 is a block diagram. The sodium, after melting, is digested for several days at 300°C with Na₂O to precipitate the CaO. After the CaO and Na₂O has settled, the molten sodium, cooled to 110°C, is decanted off the top to a metering cup and then to the evacuated cell. The sodium is moved through the system by inert gas pressure. This purification method dropped the Ca content of the Na from 450 ppm to 15 ppm. The oxide removal is unknown. Although a surrogate cell was filled on this system, no working cells have been filled and started. It may be necessary to add filters and Zr-Ti oxide scavenging devices to the system.

Filling the sulfur side of the cell is straightforward. The pre-purified sulfur is added to the reservoir, is forced into a metering cup, and hence to the evacuated cell.

4. Electrical Cell Testing Apparatus

Figure 19 is a photograph of the 5 cell electrical testing apparatus. A 25 cell testing station is being assembled based on this design. A block diagram is shown below:

Cells

Control System

Data Acquisition System

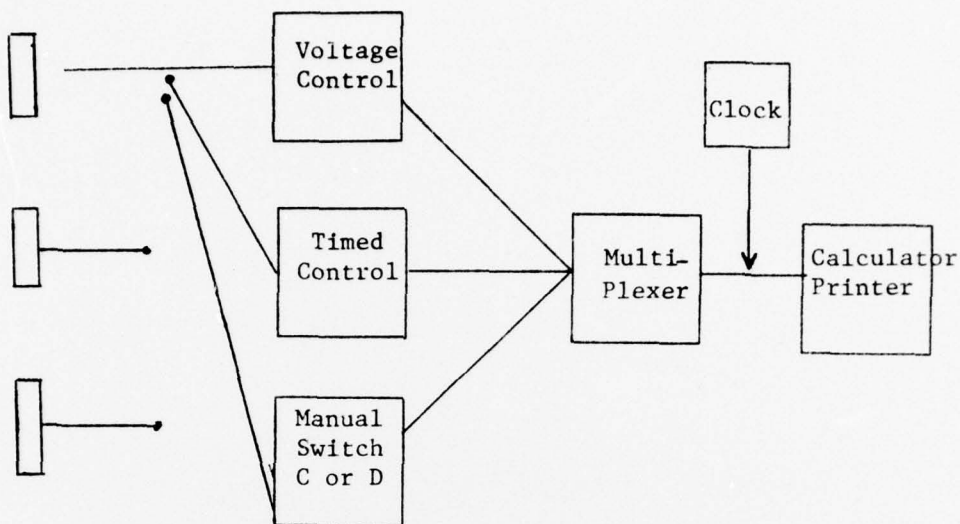

Each cell can be charge-discharge cycled to predetermined voltage cut-offs, to predetermined time cut-offs, or to manual cut-offs. At any desired time in the charge-discharge cycle, the cell terminal voltage, the cell current, and the open circuit voltage are sampled, the cell resistance calculated, and the data printed along with cell identification number and the time. Usually, this information is taken at the end of a discharge cycle just at the switch point.

Cell voltages and currents can be read continuously from built-in meters if desired. For increased reliability, the control system is not dependent on the data acquisition system. The control system contains safety devices such that if the cell voltage falls outside the range of the switching set points, the charge-discharge circuit to that cell opens up and the cell goes on open circuit.

The system has been in operation for several months with only occasional breakdowns.

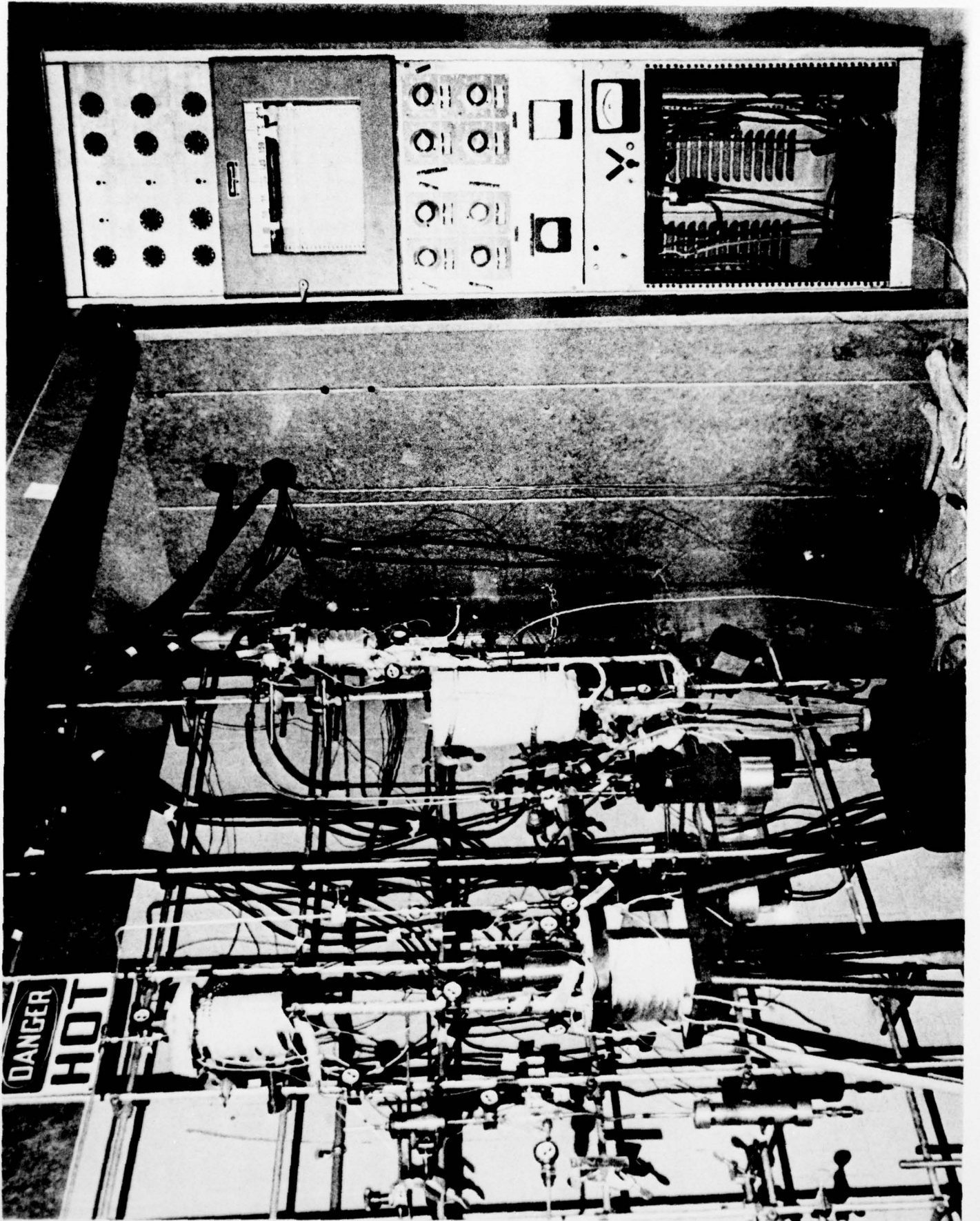

**DANGER
HOT**

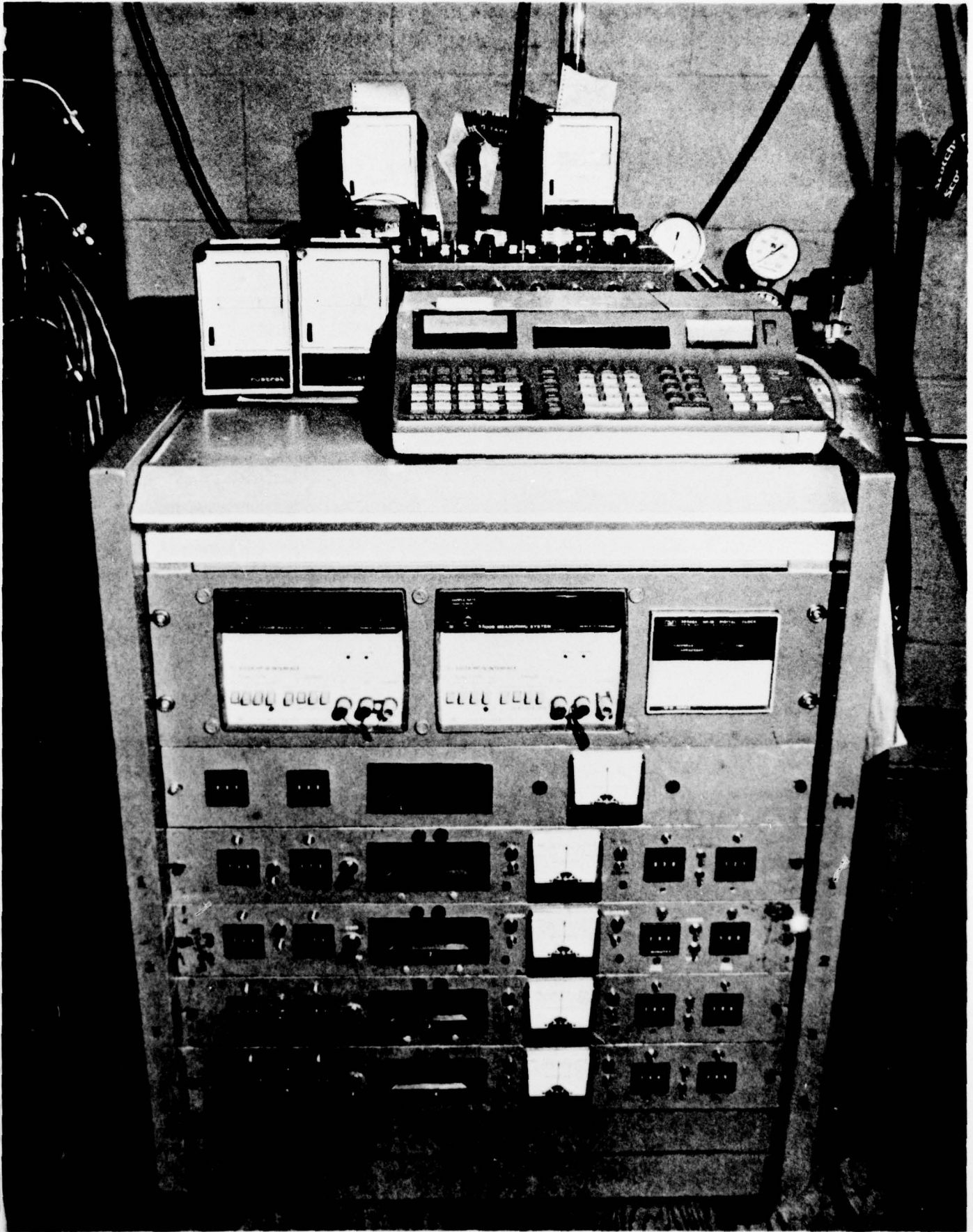

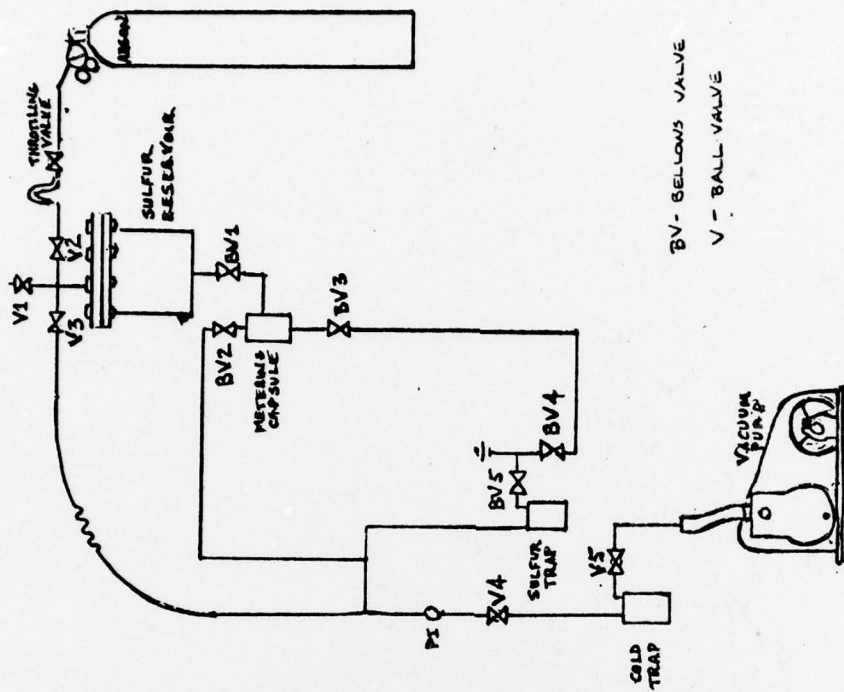

S Filling Side

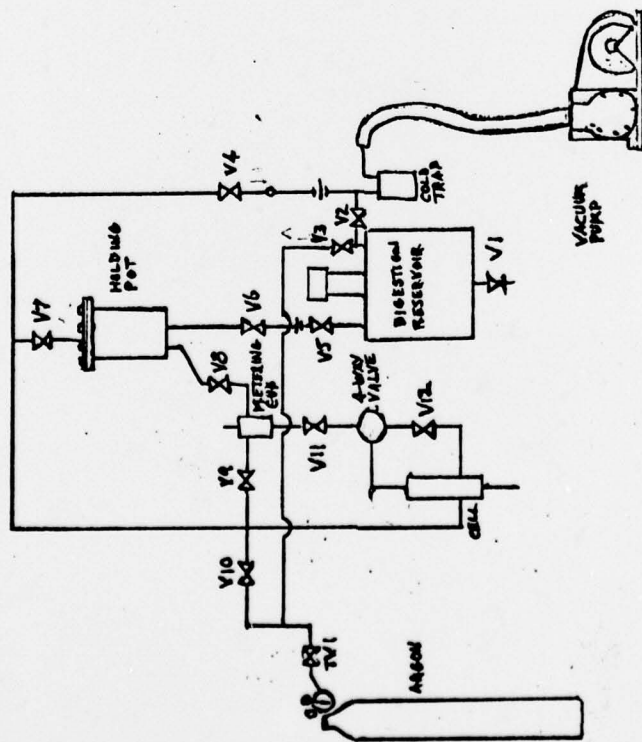

Na Filling Side

DISTRIBUTION LIST

Advanced Research Projects Agency
1400 Wilson Blvd.
Arlington, Virginia 22209

Attn: Dr. Stanley Ruby (16 copies)
Attn: Director, ARPA (2 copies)

TACTEC
Battelle Memorial Institute
505 King Avenue
Columbus, Ohio 43201

Prof. George Janz
Dept. of Chemistry
Rensselaer Polytech Inst.
Troy, New York 12181

Mr. Norman Rosenberg
Code TMP
Transportation Systems Center
Kendall Square
Cambridge, Mass. 02142

Dr. Steven Weiner
Ford Motor Company
Scientific Research Staff
P. O. Box 2053
Dearborn, Michigan 48121

Dr. Kurt Klunder
Energy Research and Development Agency
20 Massachusetts Avenue
Washington, D.C. 20545

Dr. Stuart Fordyce
NASA-Lewis Research Center
MS 302-1
Cleveland, Ohio 44135

Dr. Paul Nelson
Chemical Eng. Div.
Argonne Nat'l. Laboratory
9700 S. Cass Avenue
Argonne, Illinois 60440

Defense Documentation Center (12 copies)
Cameron Station
Alexandria, Virginia