

ADA 037357

TECHNICAL REPORT  
76-6-AMEL

**FEASIBILITY STUDY FOR A STRUCTURALLY  
EFFICIENT, MULTI-MODAL SHELTER CONCEPT  
UTILIZING ADVANCED TECHNOLOGY  
PRODUCTION TECHNIQUES**

Design Research Collaborative  
University of Cincinnati

Approved for public release;  
distribution unlimited.

February 1974

**UNITED STATES ARMY  
NATICK RESEARCH and DEVELOPMENT COMMAND  
NATICK, MASSACHUSETTS 01760**



**Aero-Mechanical Engineering Laboratory**

Approved for public release; distribution unlimited.

Citation of trade names in this report does not constitute an official indorsement or approval of the use of such items.

Destroy this report when no longer needed. Do not return it to the originator.



20. Abstract (Cont'd)

shelters from the container mode to a three for one expandable shelter. The report emphasizes consideration of potential, low cost, mass production techniques of the future such as injection molding, roto-molding and filament winding.

## PREFACE

This report was prepared by the University of Cincinnati Design Research Collaborative under Exploratory Development Project 1T762723AH98, Clothing and Equipment Technology, Task 36, Work Unit 011BG, Studies in the Mechanics of Tentage Materials and Structures for the US Army Natick Research and Development Command, Natick, Massachusetts. At the time of the preparation of this report, the US Army Natick Research and Development Command (USANARADCOM) was called US Army Natick Laboratories (NLABS). The text of the report does not reflect this name change.

The purpose of this study was to investigate all structural concepts feasible for building structurally efficient shelters of varying lengths using common components. The report includes numerous methods of fabrication such as roto-molding, filament winding, injection molding, etc., with the objective of mass production in mind within a 5 to 7 year time frame. Also considered in this study were a large number of basic monocoque and frame and panel design concepts with their respective methods of expansion from the basic container mode to a three-for-one expandable shelter. Commonality of hardware and structural components was investigated with respect to fundamental design criteria and various methods of fabricating this type of structure.



TABLE OF CONTENTS

	<u>Page</u>
LIST OF ILLUSTRATIONS. . . . .	v
LIST OF TABLES . . . . .	viii
TABLE FOR CONVERSION FROM BRITISH UNITS TO SI UNITS. . . . .	1
I.    Introduction . . . . .	2
II.   Background & Objectives . . . . .	4
III.  Design Research Collaborative's Problem Approach . . . . .	6
A.  Preliminary Evaluation Plan. . . . .	7
B.  Redirection Plan . . . . .	7
IV.  Materials & Processes . . . . .	11
A.  Material Descriptions. . . . .	13
B.  Material/Characteristics Ranking . . . . .	22
C.  Manufacturing Processes. . . . .	24
V.   Structural Analysis. . . . .	65
VI.  Design Configurations . . . . .	86
A.  Requirements Review. . . . .	86
B.  Configuration Alternatives . . . . .	101
C.  Design Configuration Catalog . . . . .	103
VII. Evaluation . . . . .	170
BIBLIOGRAPHY . . . . .	187
APPENDICES	
A.  The Structural Design Language Computer Run (STRUDL). . . . .	191
B.  Sample Calculations for Structural Efficiency Of A Frame and Panel Design Concept Versus Various Monocoque Techniques . . . . .	202
C.  Technology Sources . . . . .	212



## LIST OF ILLUSTRATIONS

<u>Figure No.</u>	<u>Title</u>	<u>Page No.</u>
1.	Container Dimensions . . . . .	2
2.	Nonexpandable & Expandable Shelter Dimensions	3
3.	Material Composites . . . . .	21
4.	Straight Vacuum Forming . . . . .	25
5.	Drape Forming . . . . .	25
6.	Matched Mold Forming . . . . .	26
7.	Pressure Bubble, Plug Assist Forming . . . . .	26
8.	Plug Assist Vacuum Forming . . . . .	27
9.	Plug Assist Pressure Forming . . . . .	27
10.	Trapped Sheet, Contact Heat, Pressure Forming	28
11.	Vacuum Snap-Back Forming . . . . .	28
12.	Pressure Bubble, Vacuum, Snap-Back Forming	28
13.	Injection Molder Pressure Systems. . . . .	33
14.	Multiple Injector Units . . . . .	34
15.	Sequential Injection Molding Process . . . . .	35
16.	Rotation Molding Laminar Flow . . . . .	39
17.	Rotational Molding Batch System . . . . .	41
18.	Rotational Molding Shuttle System . . . . .	42
19.	Rotational Molding Continuous System . . . . .	43
20.	Rotational Molding Rock & Roll System . . . . .	44
21.	Filament Winding Setup . . . . .	48
22.	Pultrusion Process . . . . .	53
23.	Bonding Of Composite Panels . . . . .	54
24.	Composite Failures in Panels . . . . .	56
25.	Sandwich Panel Strength . . . . .	57
26.	Section of Honeycomb Material . . . . .	61
27.	Frame Member Designation . . . . .	73
28.	Frame Rack Resisters . . . . .	73
29.	Filament Winding Configurations . . . . .	78
30.	Cross-Section of Ribbed Panel . . . . .	83

<u>Figure No.</u>	<u>Title</u>	<u>Page No.</u>
31.	ISO Corner Fitting Attachment Hardware . . . . .	91
32.	Sling Lifting Operations . . . . .	92
33.	Ground Vehicle Carrying Operation . . . . .	93
34.	Straddle Lift . . . . .	94
35.	Ground Mobilizer Operation . . . . .	95
36.	Forklift Operation . . . . .	96
37.	463L Pallet . . . . .	97
38.	Forklift Pallet . . . . .	97
39.	Straddle Lift Pallet . . . . .	98
40.	Tunnel Pallet . . . . .	98
41.	Shock Absorbing Pallet . . . . .	99
42.	Configuration A . . . . .	104
43.	Expansion Procedure . . . . .	105
44.	Longitudinal Section, Container Mode . . . . .	106
45.	Configuration B . . . . .	108
46.	Expansion Procedure . . . . .	109
47.	Longitudinal Section, Container Mode . . . . .	110
48.	Configuration C, Injection Molded or Thermoformed . . . . .	112
49.	Configuration C, Filament Wound . . . . .	113
50.	Expansion Procedure . . . . .	114
51.	Longitudinal Section, Container Mode . . . . .	115
52.	Longitudinal Section, Container Mode . . . . .	115
53.	Configuration D . . . . .	117
54.	Expansion Procedure . . . . .	118
55.	Longitudinal Section, Container Mode . . . . .	119
56.	Configuration E . . . . .	121
57.	Expansion Procedure . . . . .	122
58.	Longitudinal Section, Container Mode . . . . .	123
59.	Configuration F . . . . .	125
60.	Expansion Procedure . . . . .	126
61.	Longitudinal Section, Container Mode . . . . .	127
62.	Configuration G . . . . .	128

<u>Figure No.</u>	<u>Title</u>	<u>Page No.</u>
63.	Expansion Procedure . . . . .	130
64.	Longitudinal Section, Container Mode . . . . .	131
65.	Configuration II . . . . .	132
66.	Expansion Procedure . . . . .	133
67.	Longitudinal Section, Container Mode . . . . .	134
68.	Configuration I . . . . .	136
69.	Expansion Procedure . . . . .	137
70.	Longitudinal Section, Container Mode . . . . .	138
71.	Configuration J . . . . .	140
72.	Expansion Procedure . . . . .	141
73.	Longitudinal Section, Container Mode . . . . .	142
74.	Configuration K . . . . .	143
75.	Expansion Procedure . . . . .	144
76.	Longitudinal Section, Container Mode . . . . .	145
77.	Configuration L . . . . .	147
78.	Expansion Procedure . . . . .	148
79.	Longitudinal Section, Container Mode . . . . .	149
80.	Configuration M . . . . .	150
81.	Expansion Procedure . . . . .	152
82.	Longitudinal Section, Container Mode . . . . .	153
83.	Configuration N . . . . .	154
84.	Expansion Procedure . . . . .	156
85.	Longitudinal Section, Container Mode . . . . .	157
86.	Configuration O . . . . .	158
87.	Expansion Procedure . . . . .	160
88.	Longitudinal Section, Container Mode . . . . .	161
89.	Configuration P . . . . .	162
90.	Expansion Procedure . . . . .	164
91.	Longitudinal Section, Container Mode . . . . .	165
92.	Configuration Q . . . . .	166
93.	Expansion Procedure . . . . .	167
94.	Longitudinal Section, Container Mode . . . . .	168

## LIST OF TABLES

<u>Table No.</u>	<u>Title</u>	<u>Page No.</u>
I	Multi-Modal Shelter System Development Level Table . . . . .	8
II.	Materials/Characteristics Ranking Table . . .	23
III.	Thermoforming Materials/Characteristics Table	30
IV.	Injection Molding Materials/Characteristics	37
V.	Rotational Molding Materials/Characteristics	46
VI.	Filament Winding Materials/Characteristics. .	51
VII.	Sandwich Panel Adhesives . . . . .	55
VIII.	Sandwich Panel Comparison . . . . .	59
IX.	Frame & Panel Materials/Characteristics . . .	60
X.	Allowable Stress In Framing Materials . . . .	68
XI.	Frame Sizes For Frame No. 1 . . . . .	69
XII.	Frame Sizes For Frame No. 2 . . . . .	70
XIII.	Frame Sizes For Frame No. 3 . . . . .	71
XIV.	Frame Sizes For Frame No. 4 . . . . .	72
XV.	Frame Material Study . . . . .	74
XVI.	Thermoformed Panel Configurations . . . . .	76
XVII.	Laminated Panel Configurations . . . . .	77
XVIII.	Filament Winding Facing Thicknesses . . . . .	80
XIX.	Deflection & Stress Of A Simply Supported Panel	81
XX.	Injection Molded Panel Configurations . . . .	82
XXI.	Injection Molded Material Savings Using Molded Ribs . . . . .	83
XXII.	Floor Panel Materials/Configurations . . . .	85
XXIII.	Multi-Modal Shelter System Concept . . . . .	102
XXIV.	Design Configuration Evaluation . . . . .	171-173
XXV.	Manufacturing Process Evaluation . . . . .	176
XXVI.	Materials Evaluation . . . . .	177-178
XXVII.	Material Ranking List . . . . .	179-180
XXVIII.	Material/Process Composite Score Distribution Diagram . . . . .	181
XXIX.	Frame Evaluation . . . . .	182

TABLE FOR CONVERSION FROM BRITISH UNITS TO SI UNITS

Quantity	British Units	SI Units	To Convert British Units to SI Units Multiply By
Mass	pounds mass	Kilograms	0.455
Force	pounds force	Newtons	4.45
Length	inch	meter	0.0254
	foot	meter	0.305
	yard	meter	0.91
Area	square inch	square meters	$6.45 \cdot 10^{-4}$
	square foot	square meters	0.093
Volume	cubic inches	cubic meters	$1.64 \cdot 10^{-5}$
	cubic feet	cubic meters	0.0283
Density	pounds per cubic inch	kilograms per cubic meter	$2.77 \cdot 10^4$
	ounces	grams per square meter	34
Tension	pounds per inch	newtons per meter	176
Moment of Inertia	(inches) <sup>4</sup>	(meters) <sup>4</sup>	$4.1 \cdot 10^{-7}$
Modulus of Elasticity	pounds per square inch	newtons per square meter	$6.9 \cdot 10^3$
Loading	pounds per square foot	newtons per square meter	48

FEASIBILITY STUDY FOR A STRUCTURALLY EFFICIENT,  
MULTI-MODAL SHELTER CONCEPT UTILIZING ADVANCED  
TECHNOLOGY PRODUCTION TECHNIQUES

I. INTRODUCTION

Overcoming the shortcomings of the shelters in present use by the United States Army was the developmental goal of the Multi-Modal Shelter System. This concept of a multi-modal system of buildings is a proposal of a family of shelters which contain and are transported with the appropriate functional equipment needed to achieve their functional goals. In order to achieve the high degree of mobility needed by Army/1985, all phases of transportation including helicopter sling, tactical ground vehicles, mobilizer, cargo aircraft and transport ships outfitted with International Standards Organization (ISO) corner fittings tiedowns are used to transport each member of the family.

The concept includes three shelter sizes: 6-2/3, 10, and 20 feet in the length dimension for both the non-expandable and expandable variation. (Figure 1.)

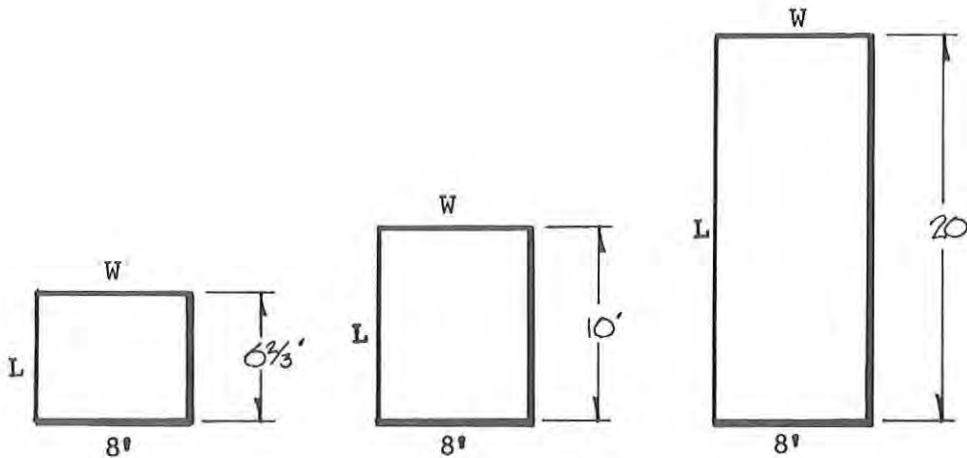

Figure 1. Container Dimensions

The width of the nonexpandable configuration is 8', while the expandable version is 8' in the packaged mode and expands to 24' in the shelter mode. (Figure 2.)

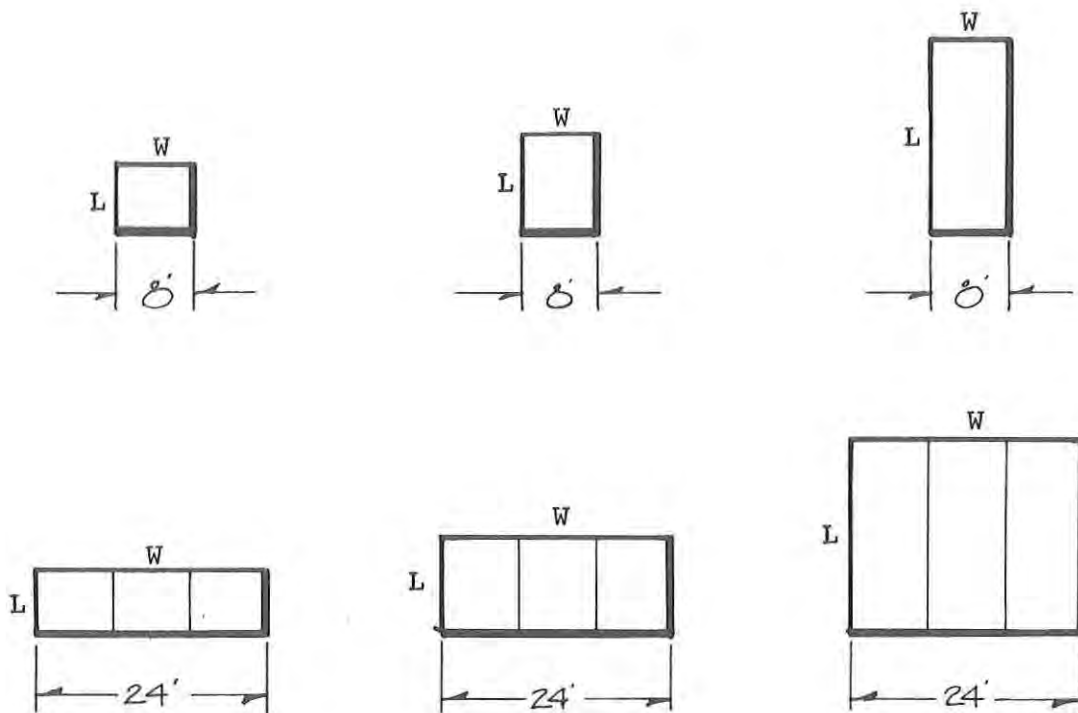

Figure 2. Nonexpandable & Expandable Shelter Dimensions

The work under this contract was performed by a group within the College of Design, Architecture & Art designated as the Design Research Collaborative. Composition of the group involves Industrial Design and Business Management faculty members, graduates, cooperative students from the Colleges of Design Architecture & Art, Engineering and a consulting Civil Engineer.

This report has been written as essentially a chronological account of the design work performed. This has been done for clarity in relaying the evolutionary aspects of the design leading to the final solutions.

## II. BACKGROUND AND OBJECTIVES

Today's army has numerous mobile shelters which serve a very wide variety of functions, including communications, food preparation, maintenance, and personal sanitation. There is considerable diversity in the design of these shelters, both in the details of their construction and in their overall configurations. Included are pods, vans, and trailers. Each of these configurations is somewhat limited in the modes of transportation applicable to it; and these transportation limitations are incompatible with the high mobility requirements of Army/1985. The savings possible through standardization and the resulting mass producibility of shelters are not achievable at present because of the diversity in design and the resulting large numbers of specialized shelter systems. It is the objective of this study to determine if expandable and non-expandable shelter concepts can be developed utilizing standard components with the structure being of efficient design in all lengths. The desired shelter system is referred to as the Multi-Modal Shelter System, MMSS.

A study of the total state-of-the-art in shelter design reveals very few concepts existing today, either in the military or civilian stockpiles, that come near answering the problems posed by the MMSS. Most of the U. S. Air Force's shelter design effort has been directed towards the repair and maintenance of aircraft and the billeting of personnel and related functions. The few concepts which approach the needs of the Multi-Modal Shelter System fail to fully answer the problems which exist. Those concepts which have certain positive aspects were evaluated and these attributes were incorporated into the overall design effort. The civilian effort has been primarily devoted to the containerization efforts which both commercial and initiating sources use to a great extent. The International Standard Organization standards have been used widely by the U. S. Army and were used in this conceptual effort as one of the base elements upon which the total concepts evolved.

The major objectives of the total work effort were:

1. To develop an understanding of advancement in the state-of-the-art that are needed to achieve the multi-modal system for 1985,
2. To consider methods of wall construction,
3. To consider methods of equipment attachment and stowage, both in transport and shelter modes, and
4. To consider the utilization of interior space in both modes.

5. To provide interface between the shelter and in various transport means.
6. To study and evaluate the methods by which a container can expand 3 for 1 in the width direction.

The outcome of this exercise is a set of design alternatives which fulfill the needed requirements of the contract, and provide a basis for detailed design work during a possible future effort.

### III. DESIGN RESEARCH COLLABORATIVE'S PROBLEM APPROACH

The following contract requirements were the constraints within which each design was evaluated.

1. Conformance with size requirements - container outside width 8 feet, inside height 7 feet, length varies from 6-2/3 to 20 feet and with a design capability for expanding any length to approximately 24 feet wide in the shelter mode.
2. Standardization of construction for all sizes to incorporate the economies of mass production.
3. Field life of 5-10 years, high reliability and low maintenance.
4. Universal attachment of functional equipment such as kitchen, maintenance, and electronic equipment.
5. Ability to withstand the following loads:
  - a. environmental loads of 40 lb /sq ft snow loads and pressure loadings of 65 knot winds and gusts of 95 knots.
  - b. loads on the floors resulting from the functional equipment associated with the wide variety of functions to be housed (approximately 100 lb/sq ft )
  - c. loads induced by transportation and handling media such as helicopter lift, road transportation, ship transport with ISO stacking provisions, ISO racking and drop standards, and dynamic loads when traversing rough terrain by mobilizers.
6. Air tightness to a degree which will make environmental control of the shelter practical.
7. Watertightness.
8. Compatibility with international standards for containerization.
9. Provide provision for a means for incorporating electromagnetic interference shields as required.
10. Weight to be minimized so that mobility will not be impaired.

## A. Preliminary Evaluation Plan

In preparation for a preliminary analysis, the Design Research Collaborative felt an evaluation sequence would function as a useful tool in the later development stages of the contract. All of the present and past state-of-the-art concepts were to be evaluated to provide an unbiased list for future reference. This plan entailed the listing of all past concepts, forming a contract requirements matrix, and scoring the concepts as to conformance with the requirements. (For example see Shelter Requirements Analysis, Contract Data Sequence #B006 of Contract F33615-69-C-1719, dated January, 1971, Design Research Collaborative, University of Cincinnati, Cincinnati, Ohio.)

The purpose of this activity was to provide a state-of-the-art base from which the future concept generation for the MMSS could evolve. Those shelters which, when rated reached a predetermined grade level, were to be set aside as a "State-of-the-art Package." This would be input into the final evaluation and would lend credence to the future designs. This important step of using the past concepts, not as design targets but, in many cases, as bad examples of total design, was considered very important in the total sequence of design. Due to the nature of the multi-modal shelter system (1985 target date), the future use of this report depends upon the reader's knowledge of past shelter design concepts and his ability to relate that knowledge to the concept work he sees presented herein.

At this point in the work program, NLABS requested that DRC not perform the past and current state-of-the-art evaluation for reasons of time savings and NLAB's dissatisfaction with all past concepts. NLABS felt that building on the past concepts and the evaluation of the state-of-the-art would hinder the conceptualization stage of the program and advised the DRC to immediately push on to the concept generation and materials and processes research stages of the MMSS.

## B. Redirection Plan

The redirection plan as called for was basically a set of development levels which broke the large MMSS into a plan of specific levels of concentration (See Table I)

### Level 1

MMSS Concept: Contains all contract requirements for the concept and all agreed upon NLAB & DRC input.

TABLE I. MULTI-MODAL SHELTER SYSTEM DEVELOPMENT  
LEVEL TABLE

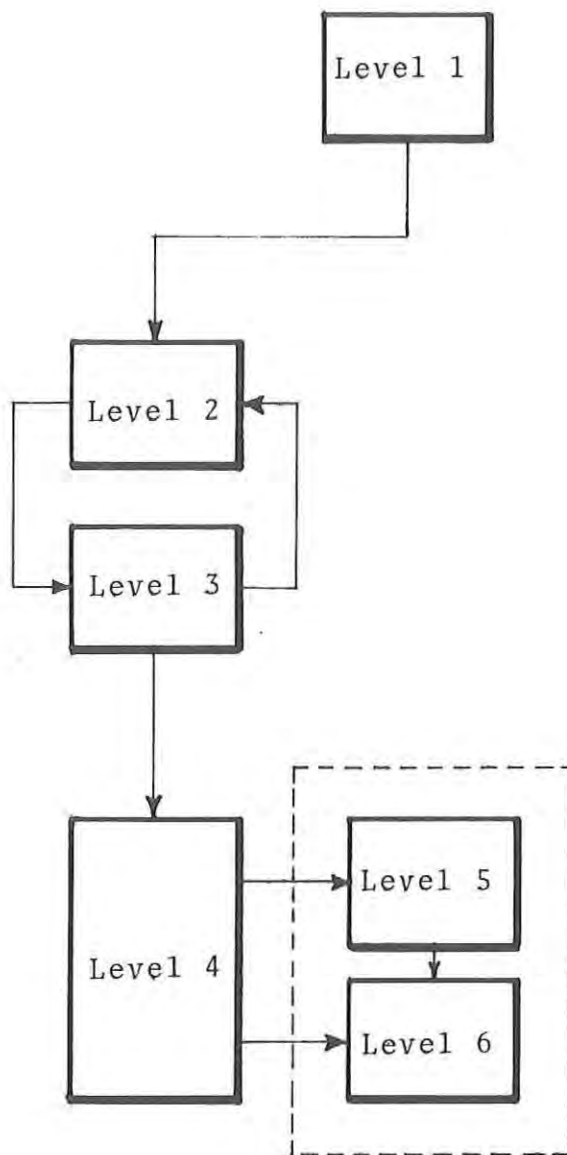

Level 2

Material/Process Level: using the above general descriptions of the overall problem, five basic manufacturing processes are agreed upon as possible successful methods of producing shelters based on concepts presented. Under this level, each process was to be researched and the materials suitable to each process were to be categorized with it.

Future projections as to costs, size possibilities, material matrices, and other design parameters, were to be reviewed and graded as to feasibility.

### Level 3

Structural Level: Basic structural calculations are carried out for each Material/Process level to give the designer a feel for material thicknesses and reinforcement patterns which could be necessary with different design configurations. Environmental loads, cargo induced loads, ISO transportation and stacking loads are all the bases for these calculations along with the materials and processes information. Plates, beams, columns, and their interrelationships are looked at to arrive at as many different concepts as possible from which to build configurations.

### Level 4

Configuration Level: Several working configurations evolve from each of the previous levels by analyzing the following factors:

1. articulation - basic methods by which containers can expand to a 3 for 1 in the width direction
2. stowage, internal access of equipment in both container and shelter modes, attachment points for cargo stowage.
3. major component interchangeability and overall modularity.

### Level 5

Functional Level: Configuration of the basic concepts could definitely be altered by the specific function for which it would be utilized. The ultimate solution would definitely be a "Universal Concept" which could serve all of the Army/1985 needs without any modifications or alterations. This universality concept, although ideal, is very improbable and therefore all functions were to be analyzed and each concept mated to the function which it could best facilitate.

### Level 6

Component Level: This level is best defined as the detail design level. After all functions and configurations are analyzed, a detailed design effort will take place resulting in specific plans and parts for each concept.

The levels which are to be worked on in this effort are Levels 1 thru 4 culminating in a set of configurations answering all of the contract demands as closely as possible. Levels 5 and 6, the functional and component levels, should be carry-on efforts for some future time. These levels are detail design levels and will not be employed in this contract.

#### IV. MATERIALS AND PROCESSES

When beginning the Multi-Modal Shelter System project, Design Research Collaborative evaluated several current shelter systems in order to acquire a fundamental understanding of the present state-of-the-art of shelter construction. Because of the ISO requirements of the MMSS, a basic investigation of container construction technologies was also undertaken in order to further contribute to the final synthesis. One of the goals of this study is the advancement of the current state-of-the-art of shelter design, projecting feasible technologies for 1985. With this in mind, DRC also conducted an investigation of developing construction technologies (materials and processes) in order to seek out newly appropriate and possibly better methods and materials for the MMSS concept.

For a number of reasons listed below, it was decided to investigate the potential applications of plastic materials and production technologies to the multi-modal shelter system.

- A. Plastic materials possess a number of characteristics which make them potentially good candidates for shelter components, namely:
  - 1. high strength-to-weight ratio
  - 2. high flexural strength
  - 3. high tensile strength
  - 4. high impact resistance
  - 5. easily repaired, low maintenance
  - 6. low thermal coefficient of linear expansion
  - 7. low thermal conductivity
  - 8. non-corrodible
  - 9. proven to perform well as a material for shipping containers
  - 10. well suited to a variety of mass-production methods
  - 11. great deal of design freedom allowed in final parts
  - 12. highly compatible with many dissimilar materials, allowing for synergetic composite material design.
  
- B. Because of the advancements in plastics technology over the past 30 years and appreciation of their true potential, the production of plastics has been rising rapidly to a projected 35 million tons annual production in 1975.

- C. The accelerating frequency of technological advances, and breakthroughs in the plastics industry presume an optimistic future for the application of plastics technologies in new areas of endeavor.
- D. Shelter manufacture is an open field for the utilization of plastics. The mating-up of material properties with the design requirements of the MMSS was considered a necessary area of research.

DRC conducted a preliminary investigation of plastic processing methods as follows:

- \* 1. Filament winding
- \* 2. Rotational molding
- 3. Centrifugal casting
- \* 4. Thermoforming
- \* 5. Injection-molding
  - a. solid plastic parts
  - b. structural foam plastic parts
  - c. bulk-molding compound FRP
- 6. FRP pultrusions
- 7. Hand lay-up and spray-up of FRP.

Additional areas of investigation included:

- 1. Metal extrusion processes
- 2. Plastic-coated metals
- 3. Fabrics
- 4. Adhesives
- \* 5. Honeycomb and foam-core sandwich panels.

Of the processes listed above, five (designated \*) were considered as potentially capable of being a manufacturing process for the large components of the MMSS. The materials associated with these processes seemed to be within an acceptable cost-strength overall performance range and the process technology was sufficiently advanced to project future capabilities in the MMSS size range and production volume-cost range.

From this point forward, discussion will deal with first, an overall view of the materials associated with the selected processes, and then second, a general description, specific material information, and projection for each of the processes. It must be noted that in many instances, speculation and assumptions are made concerning new materials and techniques.

## A. Material Descriptions

The following material descriptions supply a summary of research information on basic facts, properties, and sample uses of generally unfamiliar materials. Because of their extensive use in today's industry, such familiar materials as steel and aluminum are excluded from the Material Description section. The categories of materials that will be examined in this section are:

- Plastics
- Foamed Plastics
- Reinforced Plastics
- Plastic Resins
- Plastic Reinforcing Materials
- Inert and Integral Plastic Fillers
- Other Plastic Additives
- Adhesives
- Composites

### 1. Plastics

- a. Acrylic - The base compound used in the production of acrylic plastic is methyl methacrylate. Acrylic is a thermoplastic material that is used because of its desirable color, surface appearance, structural properties, weatherability, chemical resistance, and lightness of weight in a variety of applications. These applications include exterior sign facings, exterior space enclosures, and parts for component systems of all kinds (appliances, electronics, control panels, displays, and dispensers). Pure acrylic has a maximum service temperature of 160-200<sup>o</sup>F, but modified acrylics (of which a great variety exist) have been in use under higher temperatures and with increased abrasion resistance for some time. In the past, acrylic has been a medium cost plastic, expense ranging from \$.92 to 1.32/pound. Today, shortages of many raw materials point up a large field of modified acrylic use for the future. However, firm price projections are nearly impossible as is the case with nearly all plastics products.
- b. Polycarbonate - composed of three base compounds: polyester, dihydric phenols, and carbonate links. It possesses high impact strength, transparency,

wide service temperature range, dimensional stability, chemical resistance, abrasion resistance, and structural properties that make applications for polycarbonate nearly endless. However, it is in greatest demand for products when other characteristics need be coupled with transparency. A variety of acceptable plastic additives are used to control color, thermal, ultraviolet light, and mechanical properties thereby causing the price of thermoplastic polycarbonate to be moderate to high at \$2.65-3.03/pound. The versatility of polycarbonate, in some cases, easily justifies its price especially in view of a number of its mechanical properties. If raw material resources for polycarbonate can be stabilized in the future, its high strength to weight ratio will insure its extensive use.

- c. Urethane - Generally a thermosetting plastic, urethane technology has also produced a limited number of thermoplastic relatives. Solid urethane has excellent wear characteristics in industrial use. Printing rollers, valves, fuel lines, drive belts, gears, adhesives, coatings, marine devices, gaskets, and seals just to name a few products that utilize the improved hardness, high temperature range, and mechanical properties of urethane and some modified urethanes. Solid urethane elastomers are fairly costly in the area of necessary production equipment. However, raw material cost is comparable to acrylic at \$1.00 to 1.45/pound. Projections about urethane's use in the future points to modified elastomers rather than pure urethane parts.
- d. Polyethylene - Good chemical resistance, toughness, and versatility of processing are the characteristic properties of this thermoplastic material. Many of the other properties of polyethylene are controlled in a reasonable range by processing and compounding. It is available in a variety of densities and is also available in crosslinked compounds. Polyethylene generally requires antioxidation compounds in its processing and an ultraviolet light stabilizer in final use. All forms of polyethylene are used extensively in packaging, appliances, transportation, communications, construction, and housewares. Cost ranges from \$.62 to .75/pound making polyethylene fairly economical. Natural resources will, for the most part, dictate the use of polyethylene

in the future. The present rate of consumption is high and other material alternatives are necessary to insure a sufficient amount of polyethylene for critical needs in the future.

- e. Polypropylene - Thermoplastic polypropylene exhibits many of the physical characteristics of polyethylene. Modified polypropylene has greatly improved heat and chemical resistance when properly stabilized. Like polyethylene, it needs antioxidants in processing and can use an ultraviolet light stabilizer in many applications. Moderate cost of approximately \$.94/pound and a good balance of properties give polypropylene a wide variety of uses in appliances, automotive, communications, packaging and furniture. Polypropylene, again like polyethylene, accounts for a large percentage of the total plastics consumption. Therefore, some conservation of this material is necessary if we expect it to be available in the future.
- f. Polysulfone - This is an extremely rigid, strong thermoplastic. The base compound of polysulfone is dichlorodiphenyl sulfone. Polysulfone is used in many high heat situations: appliances and battery cases. It has a high heat deflection temperature, thermal stability, low mold shrinkage, high tensile strength, good dimensional stability, and chemical resistance. Its cost is reasonable at \$1.00 to 1.50/pound, and its use, for the most part, represents small quantities for specialized use. It is expected that the use of polysulfone will increase. However, it is also expected that the technological level of production will increase and some material alternative will help reduce the rate of rising consumption.
- g. Ionomer - Ionized carboxyl groups are the base for thermoplastic ionomer. Ionomer has excellent toughness, solvent resistance, low temperature impact strength and can be processed in transparent form. Maximum service temperature is between 160° and 180° which is rather low; however, this plastic's best service capacity is at lower temperatures. At approximately \$.60/pound, ionomer is a fairly low cost material. To project its use for the future is fairly difficult, but, because most applications concern use in low temperature situations, it is felt that its use will be extensive in refrigeration and moderate interior temperature situations.

- h. Epoxy - Although some modified thermoplastic epoxies have been produced, the major use of epoxy has been the thermosetting types. Protective and decorative coatings, electrical and electronic components, adhesives, structural and reinforced plastics, and construction are the major uses of the epoxy plastics group. It exhibits minimal shrinkage while curing, and cures with the release of no volatile solvents. Great versatility is achieved by its various cure properties, thermal properties, and flexible mechanical properties. Because of extensive epoxy technology, price range and future use are highly variable.

## 2. Foamed Plastics

- a. ABS Foam - The compound Acrylonitrile Butadiene Styrene offers a wide range of polymers that are available. Balance of properties is easily controlled by laminate expanded plies of this versatile plastic. Impact resistance, tensile strength, surface finish, and chemical resistance are its outstanding traits, while specially modified varieties are available that have extreme durability and high heat resistance. Thermoplastic ABS is used in refrigeration, food liners, and automotive applications. ABS is an extremely flexible material and used only in specific applications where its fullest resiliency can be accommodated. Expectations for projection of use hinge on the development of products and processing techniques that can fully develop the use potential of ABS laminate.
- b. Polyethylene Foam - Exhibits uniform cell size with great uniformity in thickness gage of a large section. Density of the foams can vary greatly and cross-linked foam is also available. Heat laminates of thin sheet foam is common because it has excellent dimensional stability with a good even balance of other properties. Typical applications are carpeting underlays, back up for construction sealants and expansion joints.
- c. Polystyrene Foam - In solid form, polystyrene is a rigid, brittle crystalline polymer that is made useable by modifications with flexible additives. Properties of polystyrene are greatly varied according to its processed molecular weight, additives, plasticizers, and rubber content.

Generally the material suffers from poor weatherability, limited heat resistance, and flammability. As a foamed plastic, it has uniformity of closed cells when expanded and can be formulated with an integral skin. It has been used both as structural materials and in water connected products because of its strength-to-weight ratio and because of its excellent water resistance. At \$.41 to .60/pound, it is a reasonable investment when suited to its particular abilities. Consumption of this material will most certainly rise in the future. However, all material alternatives need be explored to maximize the use of each material in plastics technology.

- d. Urethane Foam - Many varieties of urethane foams have led to increased and elevated technological achievements. Formulations vary from extremely soft flexible foams to very strong, tough, rigid foams. Closure of cells determines, to a great extent, the flexibility of the foam. Urethane foams are characterized by good dimensional stability, high thermal barriers, low water absorption, high compressive strength, and good molding characteristics. Consumption of all urethane is growing, but may greatly depend upon future material supplies. Foamed urethane (and other foams) have taken the previous place of some solid materials in industry. Foam technology still has the ability to develop more and varied foams to help defer shortages of some particular plastic materials.
- e. Ionomer Foam - Tough and solvent resistant, this foam is used in transportation, construction, automotive, and sports equipment mainly because of its adhesive character when forming. Since this foam is mainly a low to moderate temperature use material, forming operations can be done at relatively low temperatures. It also exhibits good impact resilience and high tear strength.
- f. Other Foams - This section represents a category of new foams, limited use foams, and specialty foams. New foams have limited applications and generally have not reached technological states that ensure the marketing or extended use of the new compound. Specific compounding or unique formulation leads to highly specific applications of some foams. Some foams in this category are polypropylene, polysulfone, polycarbonate, and epoxy.

### 3. Reinforced Plastics

- a. Nylon - This particular material is listed under Section III because of its projected concept use as a structural or semi-structural material. Nylon is a synthetic polymeric amide with other amide groups compounded. The properties of nylon compounds are so variable because of its ability to be successfully formulated with different additives, different fillers, different reinforcing materials, and raw material formulations. Nylon is widely used in industrial applications, gears, cams, bearings, rollers, pulleys, appliance parts, kitchen utensils, and assorted fasteners.
- b. ABS - Reinforcing materials mechanically add impact strength and rigidity. ABS normally has good dimensional stability; however, it is further improved by a variety of reinforcing materials.
- c. Polycarbonate - Characteristics that are improved include: toughness, strength, dimensional stability, thermal expansion, stress cracking, and tensile strength.
- d. Polystyrene - Reinforcement by long non-brittle fibers increases tensile strength and heat deflection temperature. Other reinforcing materials improve strength, stiffness, dimensional stability, and low temperature impact resistance.
- e. Polyethylene - Better tensile strength is evidenced when long reinforcing fibers are used. Improved characteristics are: thermal expansion, strength, stiffness, and high temperature resistance.
- f. Polypropylene - Improved characteristics are: dimensional stability, stiffness, strength, thermal expansion, and heat deflection temperature.
- g. Polysulfone - Improved molding accuracy and general improvement of all mechanical characteristics are shown.
- h. Urethane - Tensile strength and abrasion resistance are improved.

### 4. Plastic Resins

- a. Polyester - Normally a brittle thermosetting resin, polyester is widely used as a medium for all reinforcing materials. 80% of all polyesters produced are produced for reinforced plastics production while the other 20% are modified polyesters. Mechanically, polyesters assume the characteristics of the reinforcing material that is used.
- b. Epoxy - See Plastics-1.h., Section III

## 5. Plastic Reinforcing Materials

The most widely used of all reinforcing materials is fibrous glass, but many other fibrous and non-fibrous materials are used to control physical and mechanical properties. Reinforcement materials also cut most plastic costs as many fill the volume of the plastic processed reducing raw material consumption. Listed below are some common categories of reinforcing materials and examples from these categories.

- Glass Fibers
- Glass Microspheres
- Asbestos
- Carbon
- Graphite
- Cellulose
  - Cotton
  - Jute
  - Rayon
- Inorganic Fibers
  - Boron
  - Ceramics
- Synthetic Organic Fibers
  - Orlon
  - Dacron

## 6. Inert and Integral Plastic Fillers

This group of materials is used to basically, chemically or volumetrically displace a specific volume of plastic in a specific formulation. This is done to stabilize plastic compositions and cut costs of raw materials. Some examples are listed below:

- Glass
- Carbon
- Cellulosics

- Cork
- Shell Flour
- Calcium Carbonate
- Metal Flakes
- Metal Oxides
- Metal Powders
- Silica Products
  - Quartz
  - Sand
  - Novaculite
  - Colloidal Silica
- Silicates
  - Asbestos
  - Mica
  - Talc

## 7. Other Plastic Additives

This group of additives are used to chemically alter plastic properties and composition or facilitate processing.

Anti Oxidants	Processing
Mold Release Agents	Processing
Activators	Processing
Accelerators	Processing
Inhibitors	Processing
Fire Inhibitors	Plastics
Plasticizers	Plastics
Ultraviolet Light Absorbers	Plastics
Chemical Foaming Agent	Cellular Plastics
Physical Blowing Agent	Cellular Plastics
Mechanical Foaming Agent	Cellular Plastics

## 8. Adhesives

Refer to (1) Technical Discussion, Frame and Panel Technology and (2) Data contained in Materials/Processes Evaluation Chart, Frame and Panel Technology.

## 9. Composites

Following are several illustrations of composites that are considered further in materials comparison and applied processing. Cross sections graphically demonstrate both differences and similarities of material sections, giving the reader a better sense of the material configuration. (Figure 3)

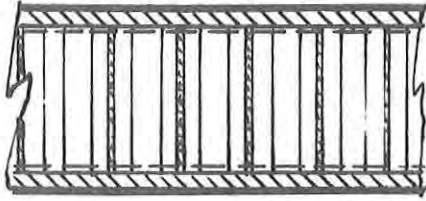

Sandwich Panel

Aluminum/Honeycomb/Aluminum

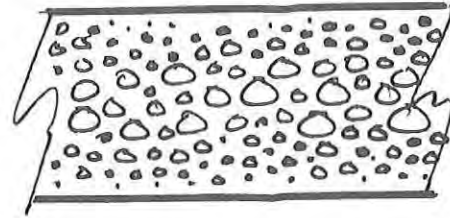

Injection Molding

Polycarbonate Structural Foam

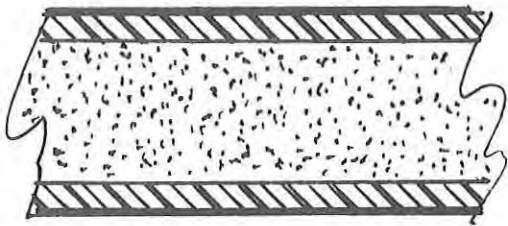

Filament Winding

FRP/Urethane Foam/FRP

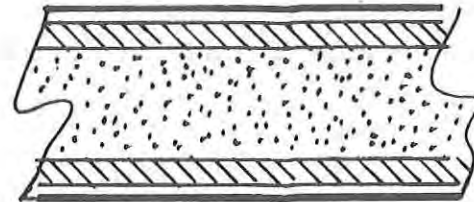

Thermoforming

Expanded ABS

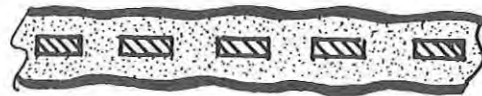

Rotomolding

Polyethylene Encapsulant/  
Aluminum Mesh Core

Figure 3. Material Composites

## B. Materials/Characteristics Ranking

The following table is a Materials/Characteristics Ranking table to show each plastic's relative position when compared to certain important characteristics. This table is a preliminary evaluation function designed to assist the selection of materials to be used in the following process section and also to be used in the final evaluation section.

TABLE II.  
MATERIALS/CHARACTERIS-  
TICS RANKING TABLE

		Lowest Density	Highest Compressive Strength	Highest Tensile Strength	Highest Impact Strength	Lowest Thermal Conductivity	Highest Maximum Service Temperature	Lowest Amount of Water Absorption	Lowest Flammability	Lowest Cost By Weight
Solid Materials	Acrylic	8	7	8	13	6	11	6	11	9
	Relate Acrylics	10	10	11	8	4	11	7	10	NA
	Polycarbonate	9	9	7	4	5	6	3	SE	12
	HDPE	4	13	13	6	10	6	1	13	6
	Cross Linked PE	3	NA	15	1	NA	NA	NA	14	NA
	PP	2	12	12	10	3	5	2	0+	8
	Polysulfone	12	8	5	NA	NA	2	5	SE	11
	Ionomer	1	NA	13	5	7	9	8	12	4
	Epoxy	14	3	6	11	9	1	4	SE	5
	Urethane	6	5	NA	1	11	9	9	SE	10
	Steel	16	2	2	7	12	NA	NA	SE	1
	Aluminum	15	11	3	NA	13	NA	NA	NA	2
	Polyester Rod FRP	13	1	1	3	2	2	NA	SE	3
	Nylon 6/6	5	7	4	9	7	8	10	SE	7
Polyester Resin	10	3	10	12	NA	NA	NA	0+	NA	
Epoxy Resin	6	6	9	13	1	4	NA	NA	NA	
Mixed Materials	P.C. 10% GRP	2	9	9	9	8	3	2	SE	NA
	P.C. 20% GRP	3	7	7	11	9	2	1	SE	NA
	P.C. 10-40% GRP	3	8	8	10	10	3	3	SE	NA
	GRP 30% Mat G	5	6	6	7	1	NA	NA	SE	NA
	GRP 50% Mat G	6	5	5	5	3	NA	NA	SE	NA
	GRP Roving Fabric	7	4	4	4	4	NA	NA	SE	2
	GRP Woven Fabric	8	2	3	3	5	NA	NA	SE	3
	GRP Uni-Direct Rov.	10	3	2	2	7	NA	NA	SE	4
	F.W. Epoxy	9	1	1	6	6	1	4	SE	1
	ABS Laminate	1	10	10	1	1	NA	NA	10	NA
Acrylic/FRP	NA	NA	NA	8	NA	NA	NA	NA	5	
Foams	ABS	8	3	4	2	6	6	NA	0+	7
	LOPE	1	NA	12	NA	1	6	1	0+	3
	HDPE	7	6	7	NA	7	5	NA	0+	5
	Cross Linked PE	2	NA	9	NA	5	NA	NA	NA	NA
	PD	8	5	5	5	NA	NA	NA	NA	6
	PS	11	3	6	3	NA	NA	NA	NA	1
	ISF Urethane	6	10	11	NA	NA	9	NA	NA	10
	Rigid Urethane	5	7	10	1	1	4	NA	NA	NA
	PC	10	1	1	NA	NA	3	NA	SE	9
	Polysulfone	11	1	1	4	NA	2	NA	NA	8
	Ionomer	3	9	1	NA	4	8	NA	SE	2
Epoxy	4	8	3	NA	1	1	NA	SE	3	

Key - SE = Self Extinguishing  
0+ = Slow Burn

## C. Manufacturing Processes

Five major manufacturing process categories were selected by the DRC as suitable candidates for the construction of the multi-modal shelter system. The process of selection of these choices was one of observation of the current state-of-the-art in Plastics & Building Technology and the future forecasts of manufacturers towards 1985. The DRC has limited its research to these five process categories due to contract time restrictions.

1. Thermoforming Technology
2. Injection Molding Technology
3. Rotational Molding Technology
4. Filament Winding Technology
5. Frame & Panel Technology

### 1. Thermoforming Technology

The basic parts or centers of a thermoforming process are 1.) a vacuum or pressurization center, 2.) male, female, and or segmented mold parts and molding assist devices, 3.) a heating element, and 4.) a platen (frame) to accept plastic sheet or plastic rolls.

Tooling for this process is relatively inexpensive. Molds serve three basic functions: 1.) determine the form shape, 2.) control dimensional tolerances, 3.) dissipate heat to cool the formed part. Molds can be made of a variety of materials. They need only be durable enough to accomplish a specific production run, surviving the heat and the drawing wear. Most molds are made of cast or machined aluminum with some in copper beryllium.

Sheets or rolls of thermoplastic material are fed into the platen. (Platens currently are available 12' x 26' with great probability of larger ones in the near future.) The plastic is heated in place until it reaches optimum forming temperature. The plastic sheet is then used to cover the mold surface, effectively producing an air tight seal draped over the male mold or stretched across the female mold. At this point the air remaining between the sheet and the mold is evacuated. Generally, vacuuming through small holes on the surface of the mold draws the plastic sheet against the mold surface. An alternative to this is raising external pressure to force the air, trapped between the sheet and the mold, through the surface holes in the mold and push the plastic against the mold surface. The two methods

described for final evacuation of air between sheet and mold can be performed simultaneously. After cooling, the finished form can be removed from the mold.

Some thermoforming techniques are also available that employ certain forming assist methods. Some examples are pre-stretching of the plastic sheet during the molding cycle, and assist plugs that roughly position the plastic in the mold before final evacuation.

To accomplish the desired finished form, careful attention must be given to mold design and the selection of one of the particular thermoforming techniques. These techniques are shown in abbreviated graphic and description form with some important notes on each particular technique.

#### Thermoforming Processes - Techniques

##### a. Straight Vacuum Forming

- Plastic cools as it contacts the mold surface
- Thinnest areas of final piece occur where the plastic has taken longer time to contact the mold, e.g., corners and edges. (Figure 4.)

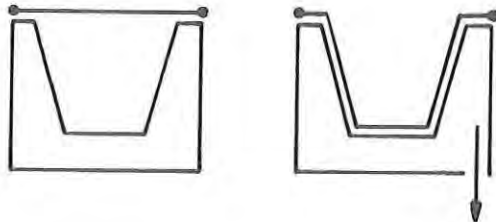

Figure 4. Straight Vacuum Forming

##### b. Drape Forming

- Same controls as A.

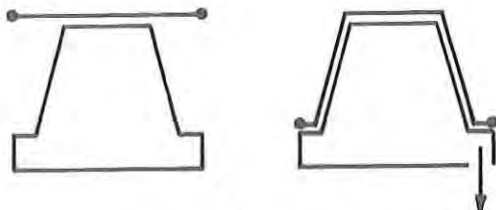

Figure 5. Drape Forming

c. Matched Mold Forming

- This forming process can yield dimensional accuracy of final part, however material distribution is greatly dependent on particular mold design. (Figure 6.)

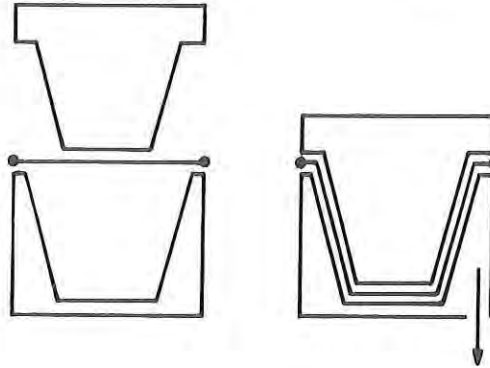

Figure 6. Matched Mold Forming

d. Pressure Bubble Plug Assist Forming

- Pre-stretches plastic sheet accommodating deeper draws with fair control over wall thickness. (Figure 7.)

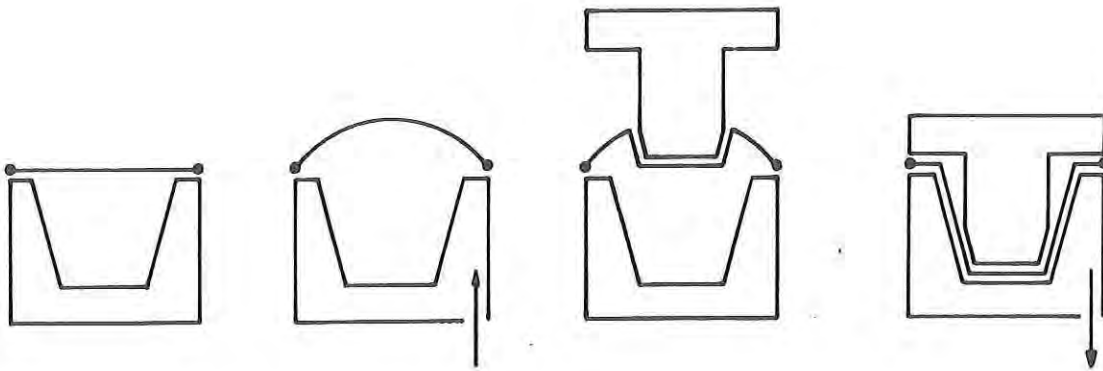

Figure 7. Pressure Bubble, Plug Assist Forming

e. Plug Assist Vacuum Forming

- Plug Assist accounts for deeper draws and pre-stretching of the sheet.
- Design of the plug controls wall thickness of final part. (Figure 8.)

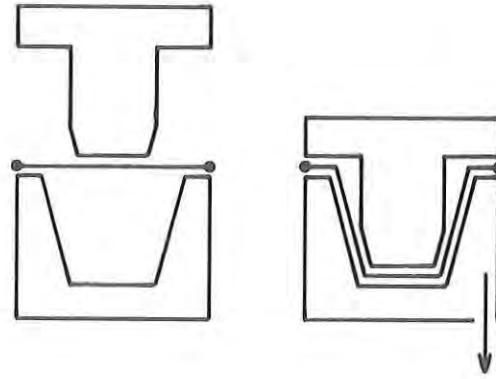

Figure 8. Plug Assist Vacuum Forming

f. Plug Assist Pressure Forming

- Use by mold design to yield uniform material distribution throughout the final part. (Figure 9.)

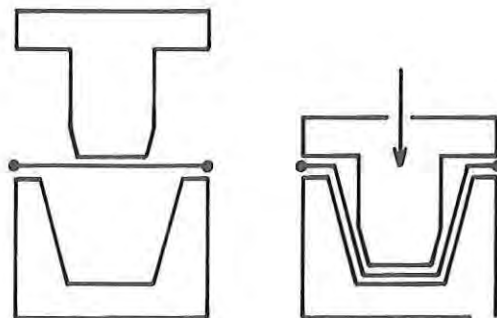

Figure 9. Plug Assist Pressure Forming

g. Trapped Sheet, Contact Heat, Pressure Forming

- Provides uniformity of sheet heating. (Figure 10.)

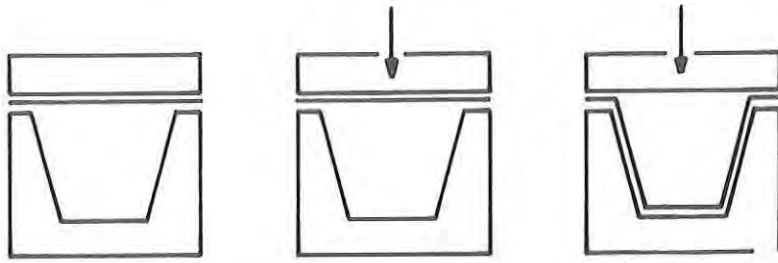

Figure 10. Trapped Sheet, Contact Heat, Pressure Forming

h. Vacuum Snap-Back Forming

- Good for externally deep draws.
- Pre-stretch of sheet helps wall thickness of final part. (Figure 11.)

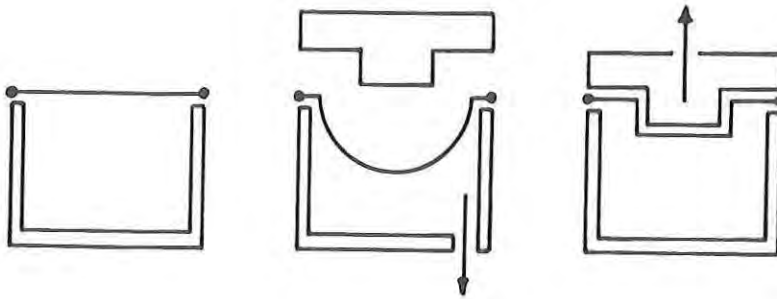

Figure 11. Vacuum Snap-Back Forming

i. Pressure Bubble Vacuum Snap-Back Forming

- Uniform Draw Characteristics
- Good material distribution and wall thickness of final part. (Figure 12.)

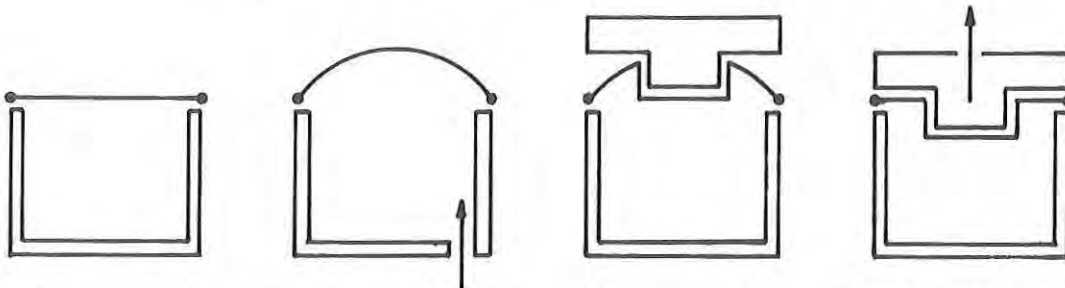

Figure 12. Pressure Bubble, Vacuum, Snap-Back Forming

## Materials for Thermoforming

### Solid Sheet

Acrylic  
Related Acrylic  
Polycarbonate  
Polycarbonate 10% GRP  
Polycarbonate 10-40% GRP

### Composites

ABS Laminate  
Acrylic/FRP Backing  
Polycarbonate/Urethane Foam Backing  
Polyethylene Foam/FRP Skin  
Polypropylene Foam/FRP Skin  
Polystyrene Foam/FRP Skin

### Foams

ABS  
Low Density Polyethylene  
High Density Polyethylene  
Crosslinked Polyethylene  
Polypropylene  
Polystyrene  
Integral Skin Polyurethane  
Rigid Skin Polyurethane

Following is a table which gives the characteristics of thermoforming materials. (Table III.)

### Key to Table III

1. Compressive Strength of foam materials is measured at the point of 10% deflection under load.
2. IZOD ft/lb/in<sup>2</sup>  
∞ - Denotes no break under impact
3. Units for Thermal Conductivity  
All "Solid Sheet" sections of materials.  
10<sup>-4</sup> Cals/Sec/CM<sup>3</sup>/1(°C/CM)  
All other materials, BTU/ft<sup>2</sup>/Hr/°F  
\* ABS Laminate in metric units
4. Ranges from maximum complete service temperature to some degradation point.



5. Testing on foams indicates water vapor absorption.
  6.
    - A Nil Effect
    - B Color Change - Slight Embrittlement
    - C Some Strength Loss; U.V. Absorber Suggested
    - D Strength Loss - Material Degradation; Requires Ultraviolet absorber
  7.
    - 0- No Burn
    - 0+ Slow Burn
    - SE Self Extinguishing
  8.
    - AA Nil Effect
    - BB Degraded by Organic Solvents
    - CC Degraded by Strong Acid
    - DD Degraded by Strong Alkali
    - EE Degraded by Weak Acid
    - FF Degraded by Weak Alkali
  9. Prices for foamed materials given as raw material cost of plastic only.
- \* The density of materials represents approximate average density of a particular material in a specific state; solid, foam, etc.

### Projection

In projected application for the multi-modal shelter system, thermoforming presents some low-cost alternatives that are not possible when considering other processes technologies.

Many of the materials listed in the material/process evaluation are speculative. With 12' x 26' platens available to industry, the size requirements of the MMSS are easily met. However, there are few production examples today that demonstrate structural thermoforming and/or very large size architectural usage products. Speculative materials, such as thermoformed foam with FRP skins, require development and may provide good to excellent technological advances for architectural uses. Panels of this material configuration would appear to be of greater structural value than other thermoformed materials, but so little is known of the actual processing that further exploration and development is necessary before a valid projection can be made.

Because of the great variety of tooling abilities and labor automation flexibility, thermoforming may provide a minimum cost option for the MMSS project. Although good amounts of waste material are generated with thermoforming, scrap could be recycled and, with a good initial tooling set up, production run can be nearly infinite in the numbers of good or excellent products produced, yielding a minimum cost solution.

## 2. Injection Molding Technology

The basic centers of the injection molding process are 1.) injection-pressure center, 2.) heating element and 3.) molds.

Tooling is initially expensive for injection molding because the process has reached advanced technologies of parts production, and the equipment has become intricately detailed with numerous auxiliary systems. A commercially available injection molding machine, standard or custom, would consist of many parts and systems operating at very close tolerances. Only the basics of the injection molding process will be considered at this point: molds, the injection pressure center, heating element, and the part produced. Molds can be extremely intricate (numerous sections, undercuts) and must be constructed of material that can withstand repeated use from high pressure molding equipment. (2-4500 ton systems with up to 30,000 psi molding pressure).

Thermoplastic or thermosetting material can be injection molded. Scrap plastic from thermoplastic molding can be reused with small preparation, while thermoset scrap is waste material. One of these materials is fed into the injection-pressure center where it is heated until it reaches optimum molding temperature. Some machines currently available can prepare up to 1400 cu. inches of plasticized material. Pressure by piston or piston and screw action then shoots the material from the injection-pressure center into the mold where the final part cools or cures. The mold controls part configuration totally. (Figure 13.)

Some injection molding techniques utilize more than one unit injecting plastic into one set of molds. (Figure 14.) Others are available that form parts consisting of more than one material, such as rigid surfaced parts with foamed cores, by sequential injections of a number of materials. (Figure 15.)

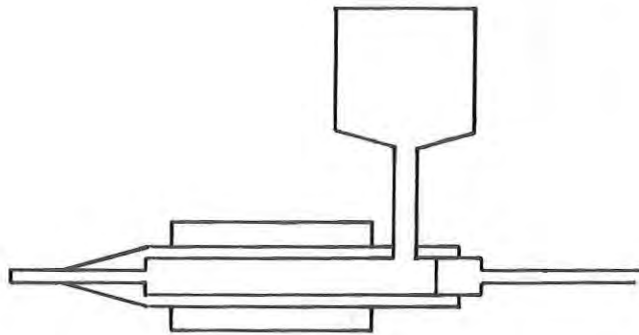

a. Pressure by Piston

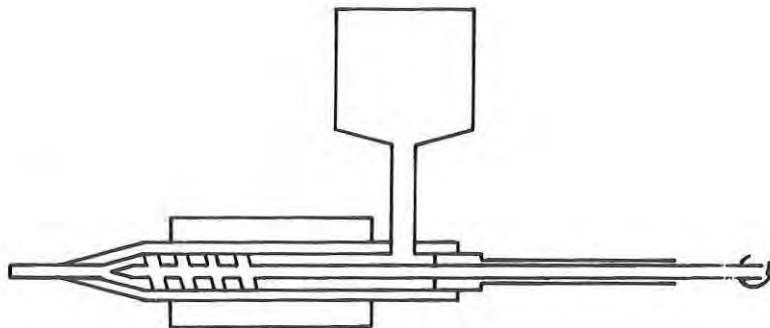

b. Pressure by Piston and Screw Action

Figure 13. Injection Molded Pressure Systems

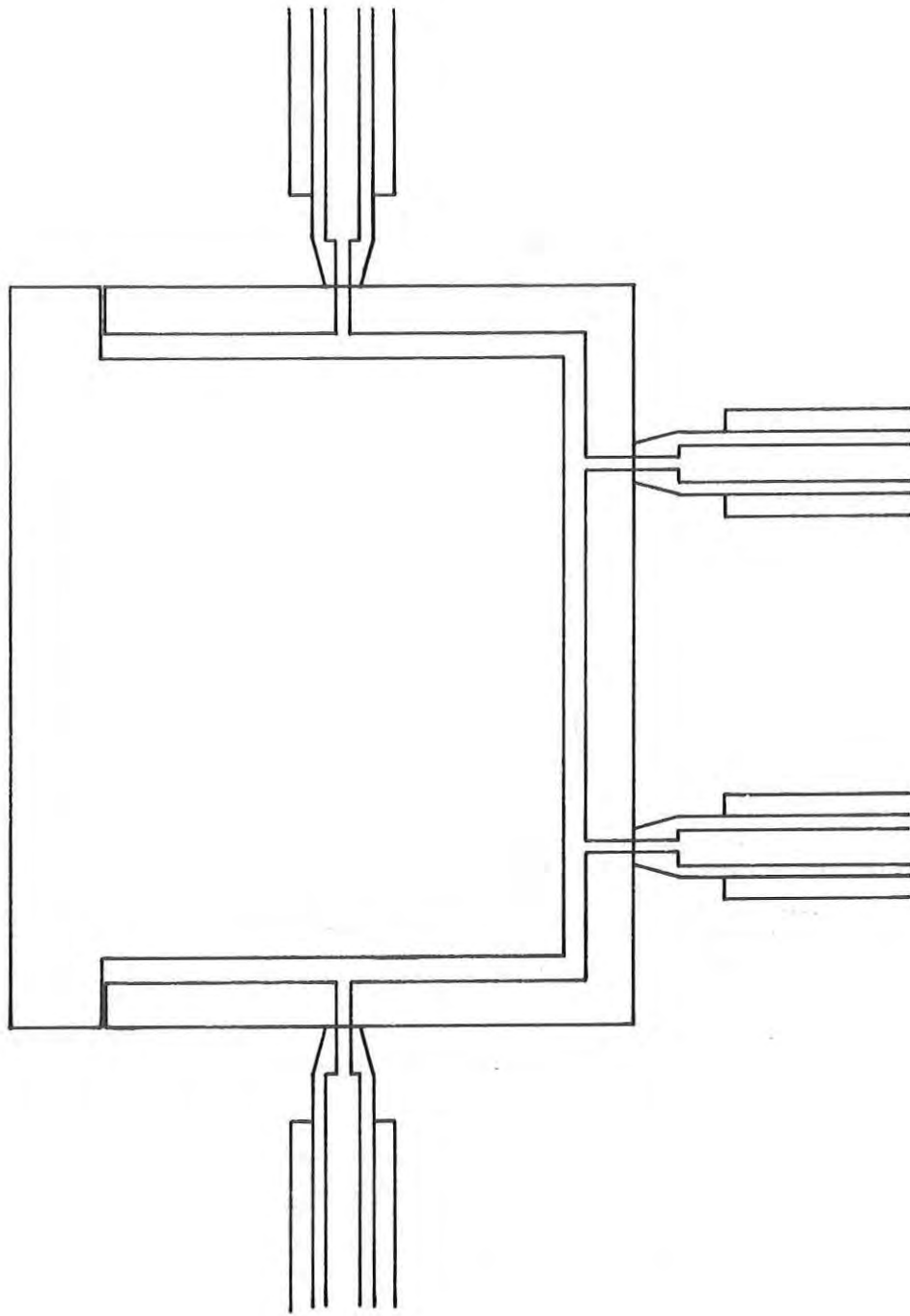

Figure 14. Multiple Injector Units

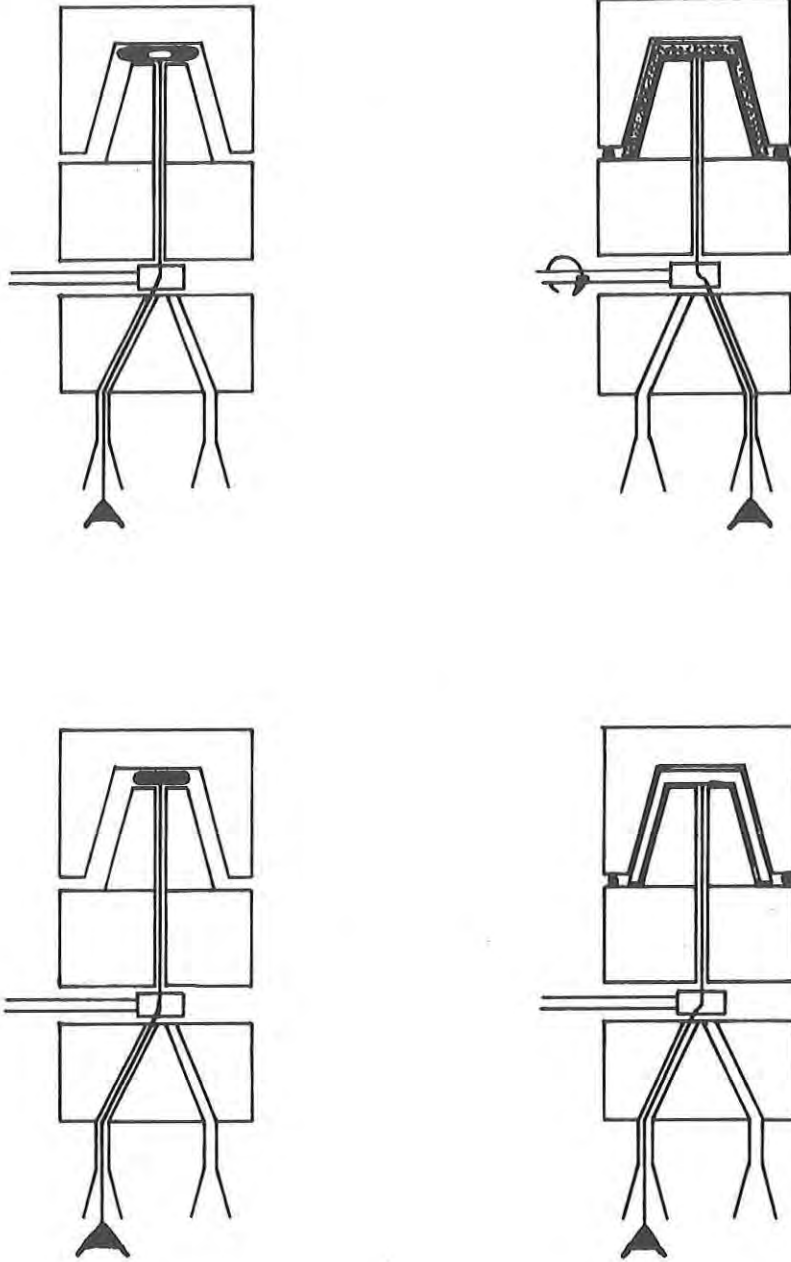

Figure 15. Sequential Injection Molding Process

Foamed parts, in particular, can be formed by mixing a blowing agent with the plastic material prior to injection. When the plastic material enters the mold, the blowing agent (already dispersed but not expanded) "foams" the plastic part that is formed.

## Materials for Injection Molding

### Solid Sheet

- Urethane
- Polycarbonate
- Polycarbonate 10% Glass Content
- Polycarbonate 10-40% Glass Content
- Polycarbonate 20% Glass Content

### Composites

- Urethane/FRP skin
- Polyethylene Foam/FRP Skin
- Polypropylene Foam/FRP Skin
- Polystyrene Foam/FRP Skin
- Polysulfone Foam/FRP Skin

### Foams

- Integral Skin Urethane
- Rigid Skin Urethane
- High Density Polyethylene Foam
- Low Density Polyethylene Foam
- Crosslinked Polyethylene Foam
- Polypropylene Foam
- Polystyrene Foam
- Polysulfone Foam
- Polycarbonate Foam

Following is a table which gives the characteristics of injection molding materials. (Table IV.)

See Key to Table III

### Projection

Although injection molding is basically a simple process, refinement and advancement in technology has allowed complex parts to be manufactured. And with this, great complexity of machines and systems have followed. Simultaneous auxiliary operations and primary operations function at, not only critical physical tolerances, but time, mechanical and material tolerances.



From the standpoint of the multi-modal shelter system, further advances in the injection molding process need to be considered. The ability to produce a side panel for one of the shelter containers in the largest size will require a part larger than 8' x 20'; currently unproducible. It is felt that custom machine and mold design will probably solve this current technical barrier. One solution might be numerous injection points on the same mold with the possibility of heated and cooled molds for material flow. However, this problem can only be solved with the proper design or engineering development.

Injection molding of foams has become rather commonplace with the technology of today. However, speculation has been done in that we would expect more foams with fillers to be injection molded in the future. Technical advances may facilitate the use of glass fabrics preset in the mold to be foam encapsulated or injection of plastic with microspheres. Possible developments for injection molding of reinforced plastic products or reinforced plastic foam products has begun but much is speculation at this point.

Injection molding presents fairly high initial cost with economies realized through low labor cost, speed of manufacture, high numbers of items produced, bulk material use, and reuse of scrap material. Technical developments are necessary to utilize the injection molding process, but we foresee no major technical barriers.

### 3. Rotational Molding Technology

General Process - There are three basic centers of a Roto-Molding Process: 1.) mold rotation devices, 2.) molds, and 3.) heating elements. Machine costs for this process can vary greatly because many are custom designed or incorporate a variety of auxiliary systems. Cast aluminum or fabricated steel are the normal mold construction materials. Molds are used to determine the final part shape and as the heated plasticizing chamber. Molds must remain dimensionally stable for heating and cooling temperatures that are normally associated with varied plastics molding temperatures.

Molds are first charged with the plastic material selected to form a particular part. Generally, two methods are used to heat and cool the molds and

plastic in a rotational operation: 1.) air and 2.) liquid. Air systems are by far cheaper and easier to run and maintain. However, liquid systems are advantageous because they have greater accuracy in temperature control tolerances (both heating and cooling). While heating the mold, part formation begins as the mold rotates in two perpendicular directions. As the material flows and coats the interior of the mold, remaining material in successive rotations applies layer upon layer of plastic in laminar flow. (Figure 16.)

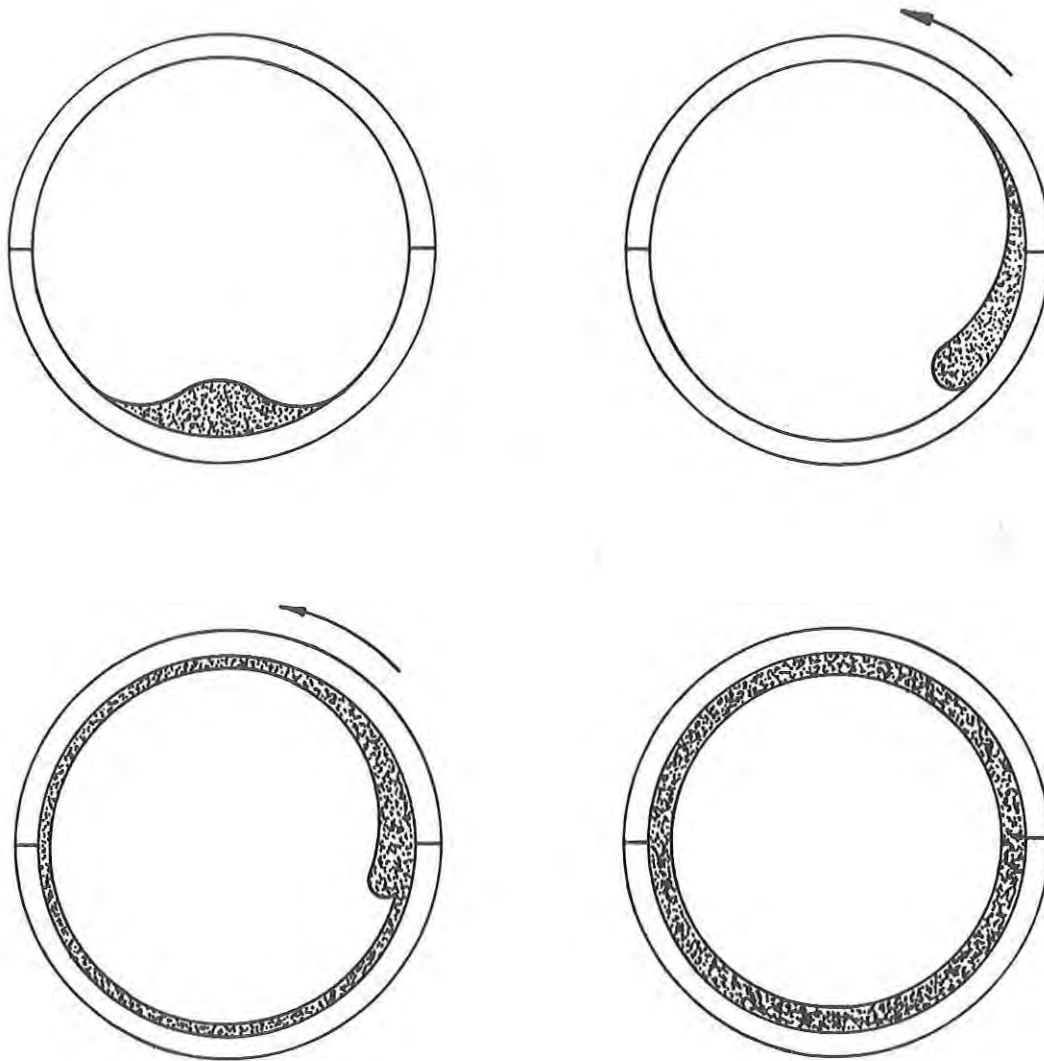

Figure 16. Rotation Molding Laminar Flow

After the charged mold has completely formed the part and exhausted material flow in the mold, cooling and ejection of the final part completes the process.

The four basic types of roto-molding machines are depicted in Figures 17-20 with some important notes on each particular machine.

Several cautions exist when considering rotational molding as a possible manufacturing solution.

1. Thickness of the parts formed is related to the area of molding and the amount of plastic in each molding charge.
2. There exists no interior mold surface to control part thickness, only exterior dimensions.
3. At temperature of molding, some plastics experience a variety of degradation due to the extended time involved in each molding cycle.
4. Selection of materials is critical to the molding time, speed of rotation and overall success of the final part.
5. Heating and cooling tolerances and cycle duration will influence the surface characteristics and the mechanical properties of the final part.

#### Materials for Rotational Molding

##### Solid Sheet

Crosslinked Polyethylene  
High Density Polyethylene  
Polypropylene  
Polysulfone  
Ionomer  
Epoxy  
Urethane

##### Cores

Steel  
Aluminum  
FRP  
Nylon

##### Foams

Crosslinked Polyethylene

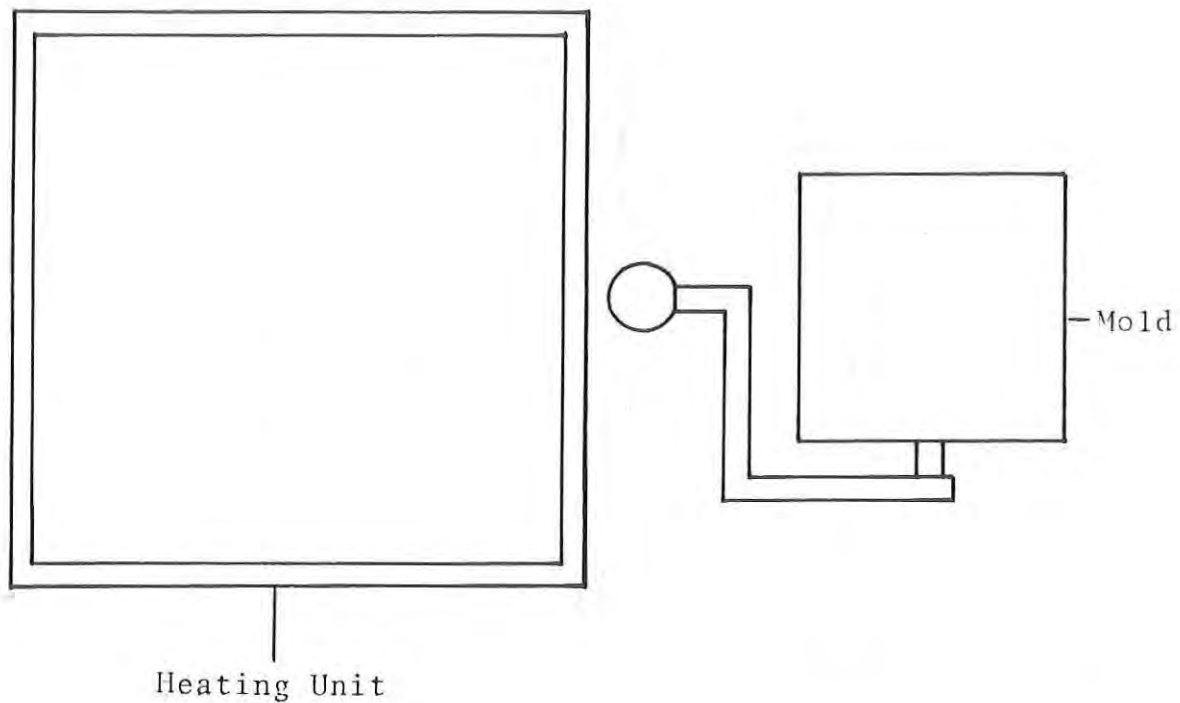

Figure 17. Rotational Molding Batch System

The Rotational Molding Batch System offers flexibility for quick mold changes, is ideal for short run and sample moldings, is a compact layout with simple operation and has minimum components for minimum maintenance.

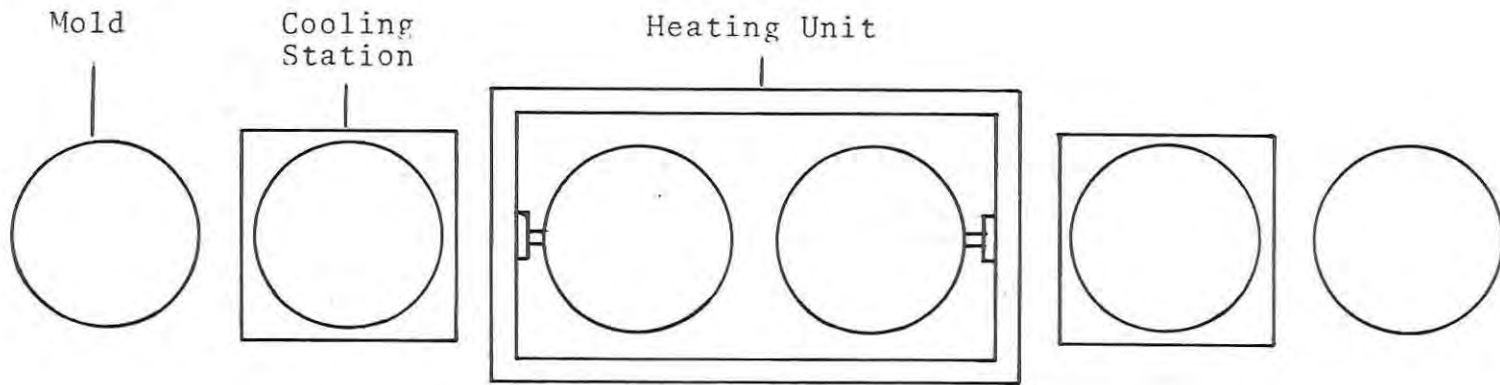

Figure 18. Rotational Molding Shuttle System

The Rotational Molding Shuttle System includes automated heating, cooling, and mold transfer. It has some flexibility for quick mold changes and is recommended for large parts.

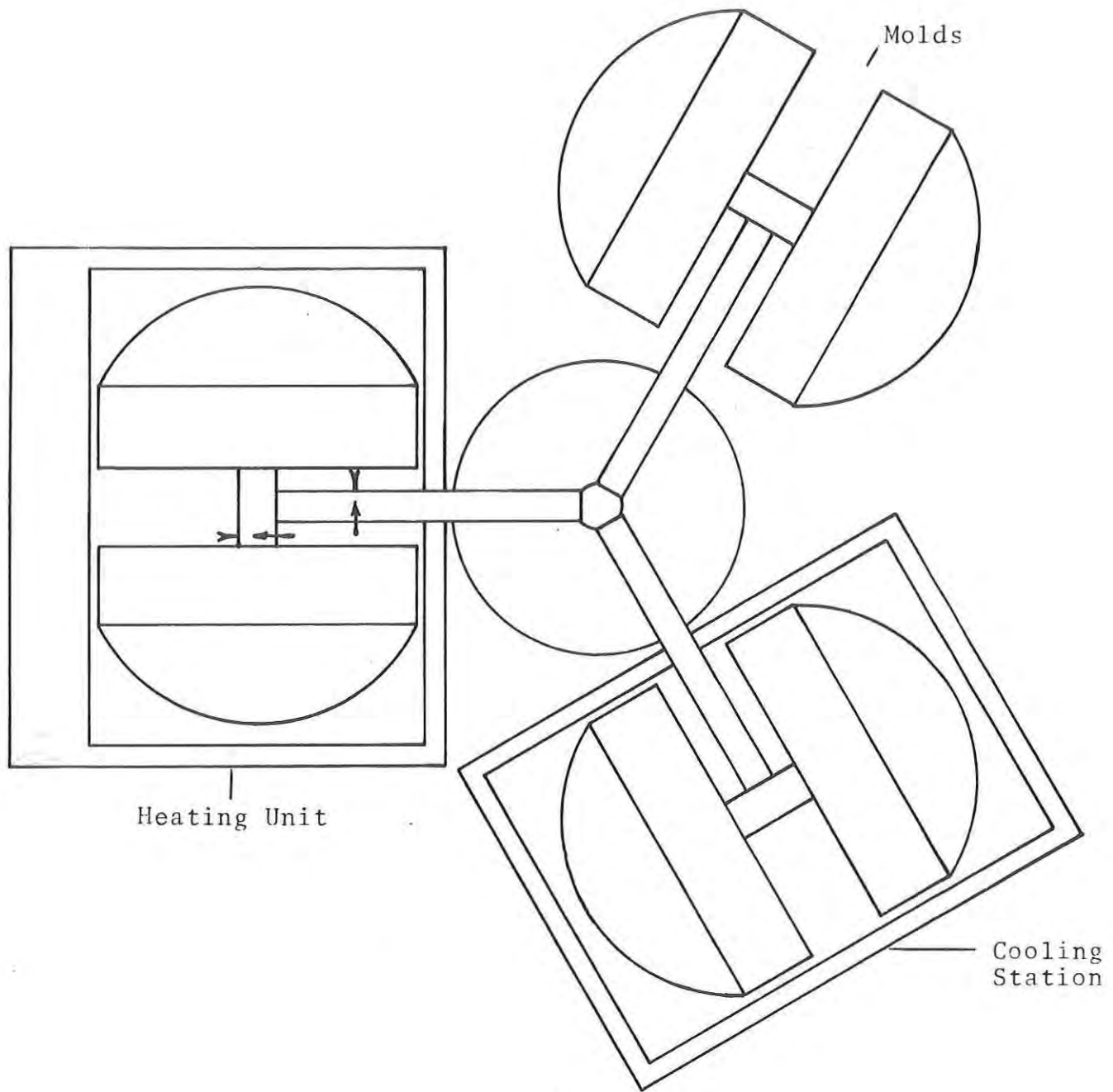

Figure 19. Rotational Molding Continuous System

The Rotational Molding Continuous System offers high production output, is highly automated and has great flexibility of part size.

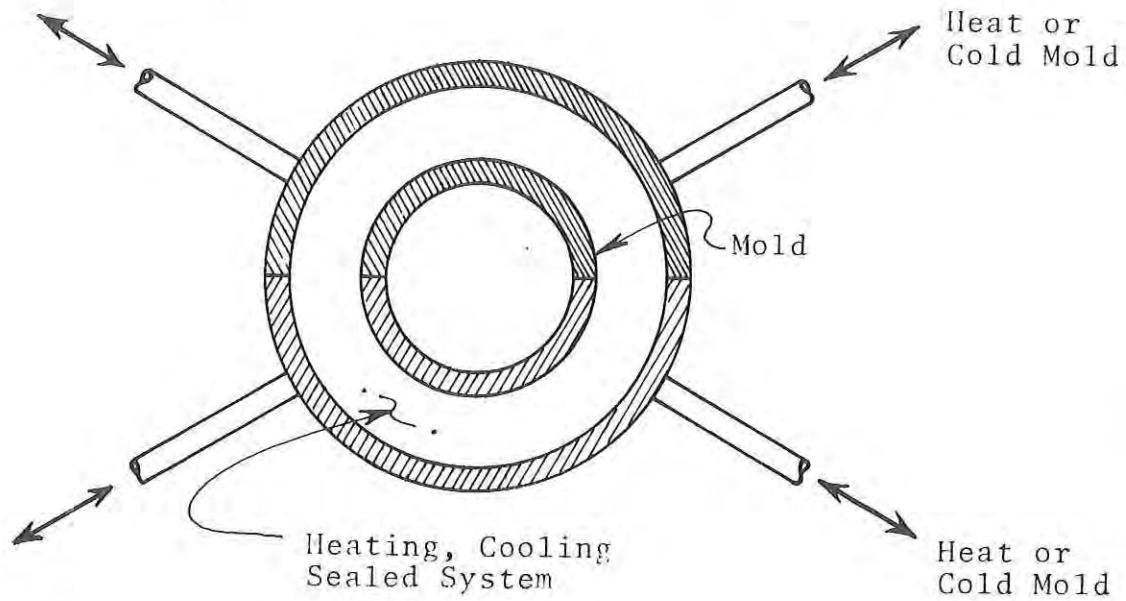

Figure 20. Rotational Molding Rock & Roll System

The Rock and Roll System is an optimum system where temperature control is most critical.

High Density Polyethylene  
Polypropylene  
Polysulfone  
Ionomer  
Integral Skin Urethane

Following is a table which gives the characteristics of rotational molding materials. (TABLE V.)

See Key to Table III

### Projection

One of the main advantages of rotational molding is the ability to produce large parts. Custom rotomolding equipment could easily accommodate sizes required in the multi-modal shelter system project.

Concept development, in considering this process, has suggested various speculative uses for shelter components. Structural or semi-structural materials encapsulated by roto-molding techniques are suggested. Also, reinforcement fillers, like glass fibers and glass microspheres, have been suggested. At present the process is restricted to thermoplastics. However, development of thermoset roto-molding techniques holds promise in the future.

It is in the areas of encapsulation and reinforcement that today's technology falls severely short. Successful rotomolding is accomplished first by proper heating and cooling of the mold in regards to the part design, the length of the mold cycle, and the particular plastic material used. When considering encapsulation of an inserted part or reinforcement by fillers or a combination of the two, all materials concerned must be thoroughly analyzed for molding properties and shrinkage and expansion. Meanwhile, experimentation on filler effects, percent of content, and resultant properties must be determined. Research and development to date has been relatively unsuccessful in encapsulation efforts. Unlike expansion, shrinkage characteristics have resulted in stress cracking, poor bonding between core and molding plastic, and generally poor encapsulation. Studies have been done using metal cores of screen, welded rods, wire mesh, punched plate and structural beams with corner fittings. With the addition of fillers, results have been complicated; less than 1 percent glass fiber fill has caused



melt/flow viscosity resulting in poor surface finishes, reduced encapsulation of forms (worse than poor), and total failure of laminar flow characteristics. Encouraging research has been done in the area of glass microsphere reinforcement of plastics for roto-molding. Microspheres have improved some mechanical characteristics of roto-molded parts while bettering melt/flow viscosity even when compared to raw, unfilled plastics. Encapsulation with microsphere plastics is speculative, but with the properties already demonstrated in part, much is expected in the near future.

Proposed core materials steel, aluminum, FRP, and nylon etc. may be experimentation supply data needed to design compatible facing and core materials in this process.

Foams have also been suggested. Some with self-skinning properties, others offering extended strength-to-weight. Experimentation with foams, reinforced foams, and foams with encapsulated cores may prove valuable in the near future.

Production economies in rotomolding are realized through both simple and complex automation of rotomolding equipment. Proper product produced at optimum design and suitability for this process would yield best economies of production.

To project the possibility of rotational molding as a process for producing a MMSS, is at best difficult because the technical barriers at present result from poor material selection in combination with other than optimum processing procedures. Only further development in this complex area will qualify roto-molding for consideration as a possible material/process solution for the MMSS project.

#### 4. Filament Winding Technology

The four basic centers of a filament wind process are as follows: 1.) filament dispenser, 2.) resin bath, 3.) rotating frame and mandrel and 4.) moveable carriage. (Figure 21.)

The size range of the part or parts produced will determine the size of the filament winding machine, and directly the cost of tooling. A filament winding system that would serve the size needs of the multi-modal shelter project would be extremely large requiring a high initial tooling investment.

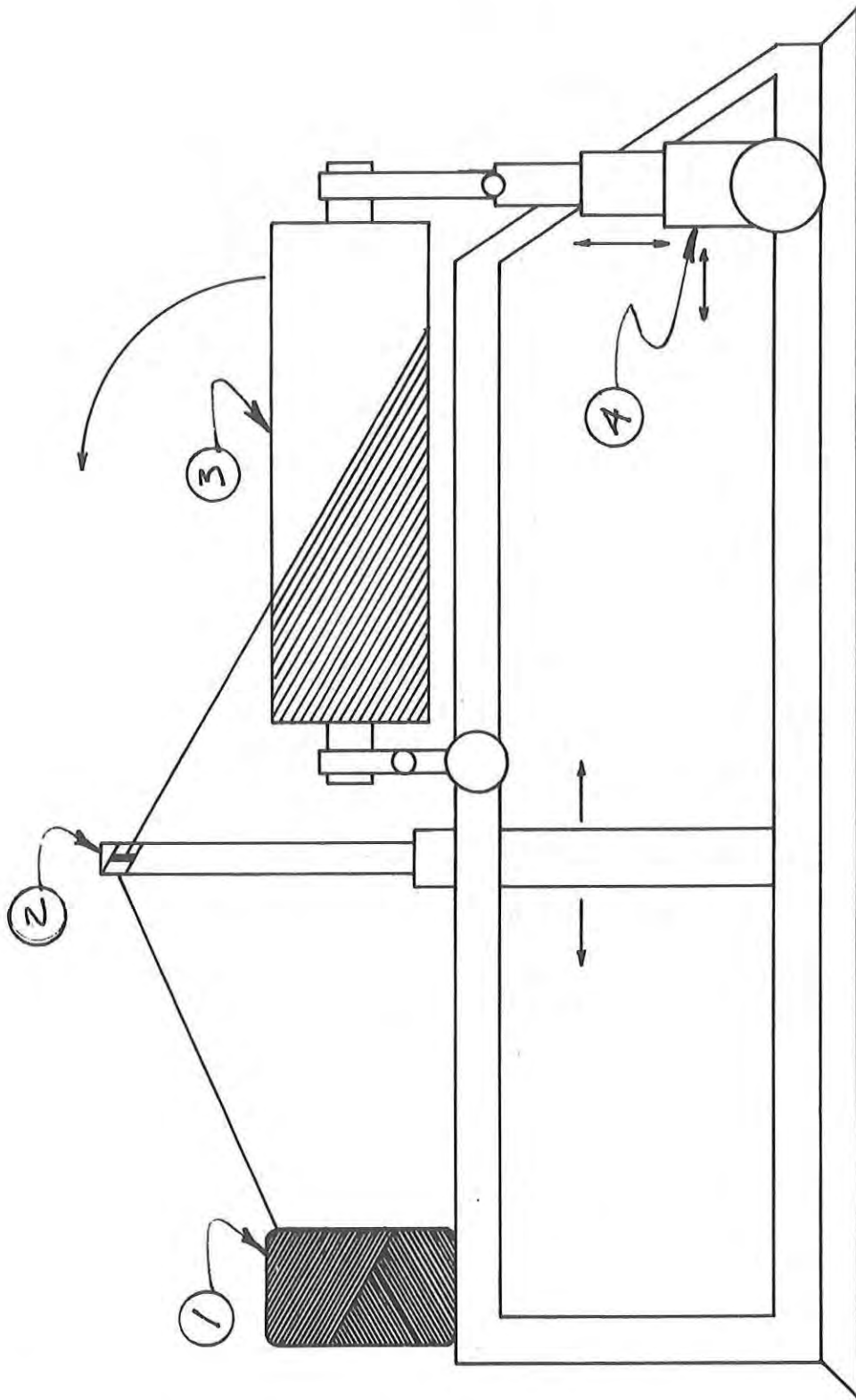

Figure 21. Filament Winding Setup

Continuous glass fiber is fed through a resin bath and then wound in successive layers on to a rotating form. The form would consist of a collapsible mandrel that, upon completion of a part, would be removed from one or both ends of the part formed. As the mandrel spins, the carriage (the frame holding the mandrel) may move, depending on the machine's particular design, in several different axes to vary the pattern of filament that is wound on the mandrel.

Because the inherent mechanical properties of glass fibers depend greatly on the type of fiber used and its particular orientation in the finished part, by crosswinding or other pre-engineering of the winding pattern a variety of structurally optimum parts can be produced with minimal amounts of material. This allows for optimum design of the final part by over-structured and understructured areas of the shelter core that may sometimes occur when other production methods are employed.

Another advantage to this process is the ability of the designer/manufacturer to create forms with sandwich type cross-sections. After an initial winding, sheet foam edge members, honeycomb and/or structural members, etc., can be bonded to the filament on the mandrel. Other layers of filament can then be wound over the mandrel, encapsulating the inserted core. This ability to design and manufacture with such latitude to meet structural requirements and material costs, not to mention the inherent properties of FRP facing with insulating core material, makes filament winding an extremely attractive processing method.

Varied types of glass filament can be used. Resins are generally thermosetting polyesters, (most common) vinyl esters and epoxies. Proper combinations of resin and filament 1.) maintain the filaments' proper position, 2.) assist load distribution, 3.) give resin protection of surface fibers, 4.) add interlaminar shear strengths and 5.) extend corrosion resistance.

Filament winding machines are of two basic types: polar winders and helical winders. Although all filament winders are restricted to "figure of rotation" part production, helical provides the greatest degree of carriage motion for varied winding patterns while polar winders have only 3° variance from horizontal or vertical. Prices are also relative to the abilities of each machine.

## Materials for Filament Winding

### Thermosetting Resins

- Polyester
- Epoxy
- Other Resins

### Glass Fibers

- Yarn
- Continuous Roving
- Spun Roving

### Glass Mats & Fabrics With Resin

- 30% Chopped Strand
- 50% Chopped Strand
- Roving Fabric
- Woven Fabric
- Uni-Directional Roving

### Facings & Composites

- Filament Wound Epoxy
- Filament Wound Polyester
- FRP/Foam/FRP

### FRP/Foam Reinforcement

- FRP
- Steel
- Aluminum

Following is a table which gives the characteristics of filament winding materials. (TABLE VI.)

See Key to Table III

### Projection

Considering that 40' x 8' x 8' ISO containers have been manufactured in the past, filament winding can be considered a suitable process for the multi-modal shelter project even today.

The major areas that need development in the future are material combinations and structural engineering. Structural configurations for winding patterns with core inserts could be fairly complex with the MMS concept (doors and other required accessories). This may be



solved with further development of the art. Also, other filament materials or thin meshed fabrics may be wound in the future.

This highly automated manufacturing process provides projection to future advanced systems control. Computer runs could completely control the process as well as determine quality of the final product. Investment in filament winding machinery is already relatively high, therefore, maximizing production by automation should be the key to economic operation of the system.

Some minor barriers that need be considered are 1.) restriction to figure of revolution, and 2.) openings into the final part (other than for the mandrel) must be produced after the part is wound because total form encapsulation occurs.

## 5. Frame and Panel Technology

Frame and panel technology can be divided into the two basic areas: frame and panels. It is important to note that the examination of frame and panel material and process technology will consist of: 1.) Materials suggestions for structural frames, 2.) Materials for simple panels, 3.) Materials for sandwich-type panels, including facings of a variety of materials and honeycomb, foam, plywood, etc., cores, 4.) Process explanation of some frame material suggestions and 5.) Process explanation of the various sandwich panels and a discussion of their strength potential. Omitted from this discussion are: 1.) Process explanation of steel and aluminum forming and 2.) Process explanation of sheet metal forming for simple panels.

### Frame Processes

- a. Steel Processing (Omitted from this discussion)
- b. Aluminum Processing (Omitted from this discussion)
- c. FRP Pultrusions Processing - Reinforced plastic pultrusions utilizing varied forms of fiber reinforcements. Various cross-sectional configurations are available; some with foamed interiors. Like an extrusion, where heated aluminum or other material is forced through a specific die (Figure 22.), pultrusions have the design flexibility of intricate cross sections with almost no limitations on extruded lengths.

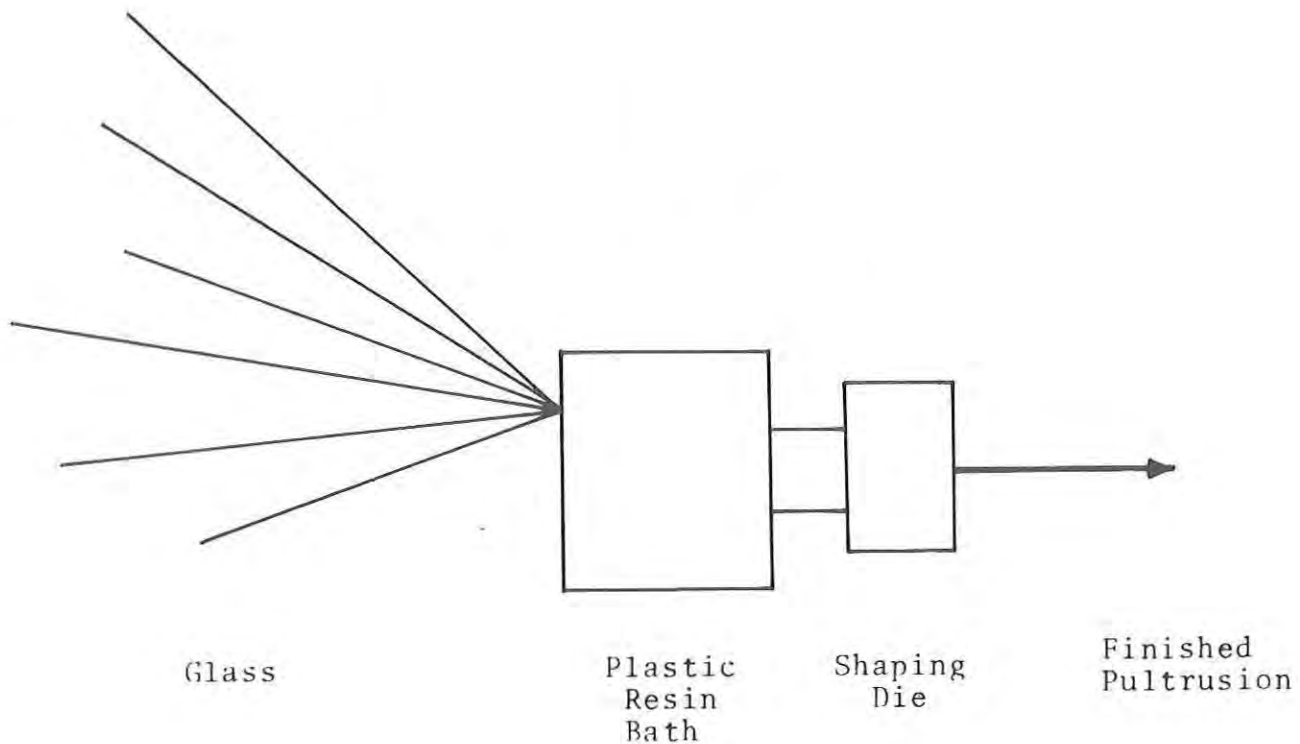

Figure 22. Pultrusion Process

### Sandwich Panels

Technology in this area centers around the mix and match of panel facings (aluminum, steel, FRP), cores (honeycomb, foam, plywood, etc.), and varied adhesives for facings, cores, bonding. To further complicate optimum design of a sandwich panel for a particular use, different combinations of cores and core materials, different thicknesses of facings and cores and even preassembly and assembly procedures contribute greatly to the efficiency of a particular panel design.

The process of panel assembly begins with thorough cleaning of both facings and cores. Clean-room conditions should be observed to minimize material's surface contamination before adhesive bonding. The assembly room should be both temperature and humidity controlled. Workers in this room should be limited in number and must also observe clean-room regulations for dress and cleanliness. Preparation of different facings and cores may require (depending on the particular material) specific techniques of primer,

sandblasting, solvent cleaning, etc., to insure adequate bond interface. Panel close-outs need careful attention and can be inserted at the assembly level of core/facing bonding. Processing techniques may vary considerably from one processor to another. However, the heat/pressure cure is fairly standard regardless of the particular processing equipment (Figure 23.)

Adhesive, Heat, & Pressure

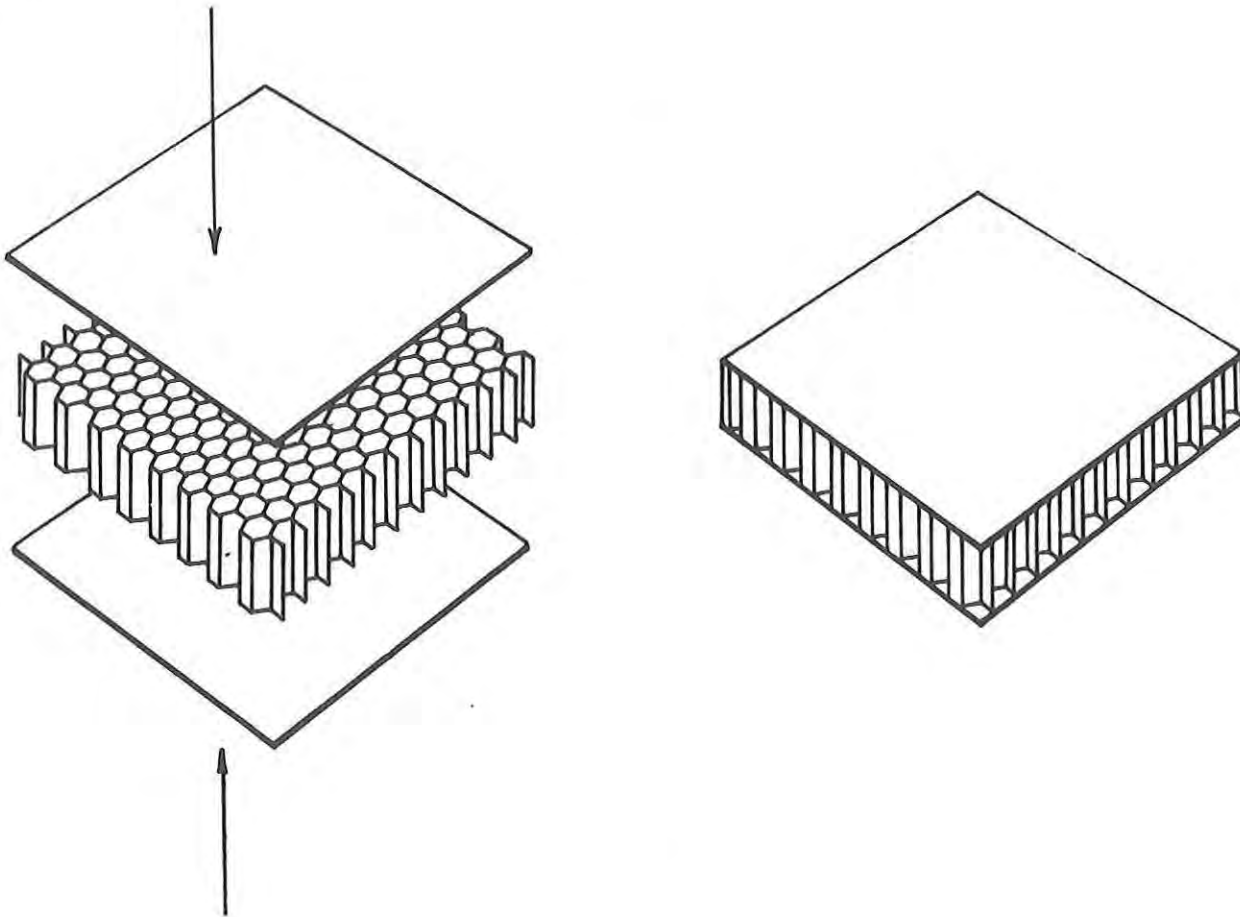

Figure 23. Bonding Of Composite Panels

TABLE VII.  
Sandwich Panel  
Adhesives

Reccom. Combinations		Adhesives							
		Nitrile Phenolic	Vinyl Phenolic	Epoxy Phenolic	Unmodified Epoxy	Modified Epoxy 250° Cure	Modified Epoxy 350° Cure	Epoxy Polyamide	Polyimide
Facings	Steel	X	X	X	X	X	X	X	X
	Aluminum	X	X	X	X	X	X	X	O
	FRP (Epoxy)	X	X	X	X	X	X	X	O
Cores	Al Honeycomb	*	*	*	X	X	*	X	O
	Kraft Paper Hcomb.	*	*	O	X	O	*	O	O
	Nomex Honeycomb	*	*	X	X	X	*	X	O
	Plywood								
	Polystyrene Foam	+	O	O	X	O	O	O	O
	Polyurethane Foam	X	X	X	X	X	X	X	O
Useful Temperature °F		-67 350	-67 225	-70 500	-67 300	-250 180	-67 250	-300 250	< 600

KEY: X - Compatible Adhesive System  
 O - Combination Not Recommended  
 \* - Compatible Adhesive System -  
 Perforated or Vented Core  
 May Be Required to Permit Escape  
 of Uncured Adhesive Volatiles  
 + - Solvent Free Adhesive System  
 Required

Adhesives can be used in many forms; liquid, powder paste, or film. (See Table VII.) At this point the adhesives best suited to sandwich construction are heat cured with pressure assist. Cold cure adhesives

exist and mechanical core-to-facing attachments can be used. However, they produce less than optimum structural designs. Sandwich panel constructions that utilize hot cure adhesives are 1.) bond interface, structurally efficient, 2.) fatigue resistant, 3.) smoothly surfaced and 4.) economical. The major shortcoming of sandwich panels is poor peel characteristics; delamination resulting in significant strength loss. (Figure 24.) Cold cure adhesives

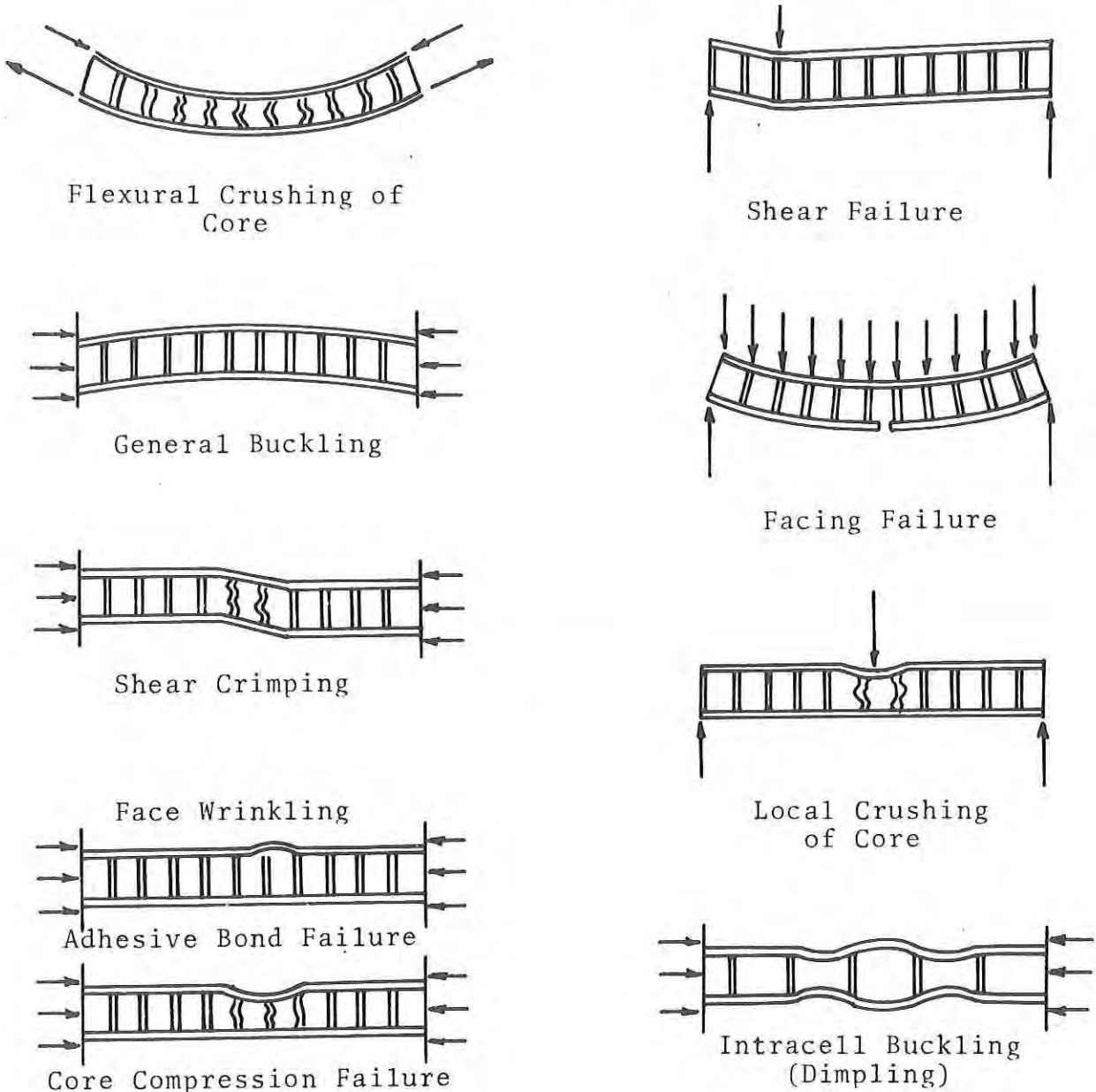

Figure 24. Composite Failures in Panels

afford less resistance to peel, therefore, ultimate strengths are less than hot-cured panels. It should be noted that some cold-cure adhesives have been formulated to surpass the mechanical properties of the hot-cure type. However, no compositions have been developed due to the speculative costs of these specific compounds. Mechanical fastening for core/facing interface lacks the structural efficiency that results from a total adhesive interface. In any further considerations of facing/core interface, only hot-cure adhesives will be evaluated because of the present faults in cold-cure adhesive systems and the technical barrier confronting mechanical systems. Hot-cure adhesive systems usually require a temperature of 250°F to 350°F until cured. For efficient bonding, platen-type presses are used to effect bonding at pressure of 20-40 psi.

It is important to note that the high efficiency and value of sandwich panel construction is achieved through proper processing of the panel and careful materials selection.

Sandwich composites can be used when the designer desires to achieve a high strength-to-weight ratio in panel configurations. Sandwiches achieve their high strength characteristics in the same manner that an "I" beam creates a structurally efficient member. See Figure 25. for comparisons. The sandwich panel

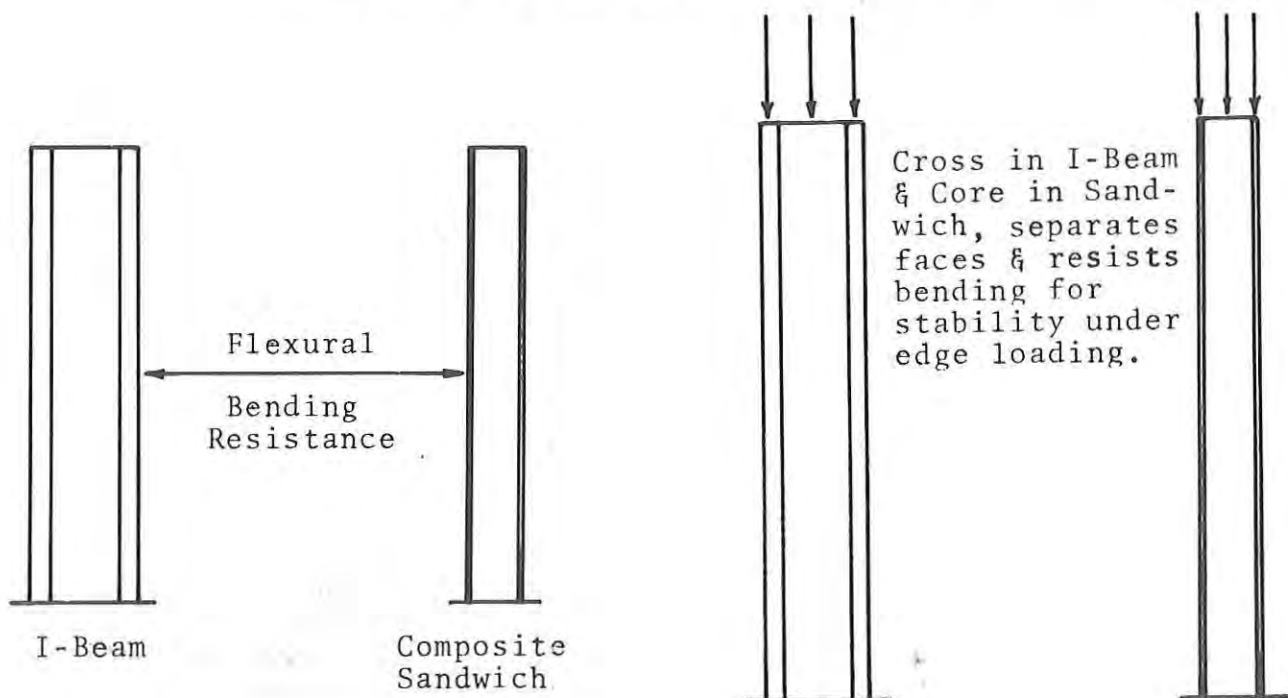

Figure 25. Sandwich Panel Strength

uses two different strength areas and properties to achieve strength. Materials of high tensile and compressive strength are used for facings while a low-strength core is employed. The basis of this structure utilizes the thin, high-strength facings to resist compressive edge loadings and the thicker low strength core, to resist bending. When a sample material is compressed edgewise over a comparatively short length, failure occurs in fracture. However, any significant length that can experience bending before fracture will do so, and the corresponding strength value decreases as the sample length and bending become a greater factor. Therefore, sandwiches utilize a core that spaces the panel facings apart (as in an "I" beam) for load distribution and a cross section that is sufficient to resist bending under panel loading. This then allows the thin facings to utilize the same high strength properties that a short test sample would. High strength because of bending resistance results.

Facings - (Aluminum, Steel, FRP) Due to the fact that all the facing materials suggested probably have ample strength properties to construct efficient sandwich panels, other characteristics play a more important part in material selection. Overall, finished panel capabilities are difficult to analyze in preliminary materials/process research, but estimations of bonding qualities for given facings and cores are necessary as are considerations of structural value in a frame, thermal properties, material costs, and corrosion resistance to name some guides to choose materials. (Refer to Tables VIII & IX.)

Cores - Suggested materials for cores are all now being used today in some sandwich constructions and, as in materials suggested for facings, all probably have ample strength properties to construct efficient sandwich panels. Certain characteristics deserve consideration when designing with honeycomb core materials. As seen in Figure 26, honeycomb materials with six-sided cells have a particular orientation. In the manufacture of the core, ribbons of adhesive in controlled lengths are placed between flat plies of the unexpanded core. When expanded, the adhesive ribbons control the configuration of each cell. Double thickness of material occurs at each adhesive ribbon. In general, the mechanical strength properties of the core are better in the length direction of the ribbons than in the width direction (perpen-

8' x 20' Sandwich Panels; Simply Supported, 40 lb/ft<sup>2</sup> Ld.

TABLE VIII.  
Sandwich Panel  
Comparison

	Steel/Styrofoam/ Steel	Al/Styrofoam/Al	FRP/Styrofoam/FRP	Steel Urefoam/Steel	Al/Urefoam/Al	FRP/Urefoam/FRP	Al/Al Honeycomb/Al	Al/Al Honeycomb/Al	FRP/Paper Honeycomb /FRP	FRP/Modified Paper Honeycomb/FRP
Total Panel Tkns. (in)	.847	1.17	1.49	.952	1.38	1.58	1.11	1.06	1.38	1.32
Single Facing Thickness (in)	.077	.106	.135	.087	.125	.144	.101	.096	.125	.12
Core Thickness (in)	.693	.954	1.22	.778	1.13	1.30	.909	.864	1.13	1.08
Facing Density lb/ft <sup>3</sup>	485	173	177	485	173	117	173	173	117	117
Core Density lb/ft <sup>3</sup>	10	10	10	10	10	10	2.0	8.1	8	3.8
Facing Weight (2) lb/ft <sup>2</sup>	6.22	3.06	2.63	7.03	3.60	2.81	2.91	2.77	2.44	2.34
Core Weight lb/ft <sup>2</sup>	.069	.095	.122	.078	.113	.130	.152	.583	.750	.342
Panel Weight lb/ft <sup>2</sup>	6.29	3.16	2.75	7.11	3.71	2.94	3.06	3.35	3.19	2.68
Facing Cost (2) \$/ft <sup>2</sup>	.63- 3.11	.70- 1.38	1.05	.70- 3.52	.83- 1.62	1.12	.67- 1.31	.64- 1.25	.98	.94
Core Cost \$/ft <sup>2</sup>	.24- .35	.32- .48	.41- .61	.65- .94	.93- 1.36	1.08- 1.57	.21	.72	.15	.27
Total Panel Cost \$/ft <sup>2</sup>	.87- 3.46	1.02- 1.86	1.46 1.66	1.35- 4.46	1.76- 2.98	2.20- 2.69	.88- 1.52	1.36 1.97	1.13	1.21
Order of Efficiency Thick.	1	5	8	2	7	9	4	3	7	6
Order of Efficiency Weight	9	5	2	10	8	3	4	7	6	1
Honeycomb Cell Size							3/16"	3/16	3/16	1/2"

TABLE IX.  
Frame and Panel  
Materials/Character-  
istics Table

	Density lb/ft <sup>3</sup>	Compressive Strength PSI (x 10 <sup>3</sup> )	Tensile Strength PSI (X 10 <sup>3</sup> )	Impact Strength Ft/lb/in <sup>2</sup>	Thermal Conductivity	Sustains Continuous Temp. °F	Adhesive Peel Quality	Bonding Temperature °F	Coefficient Linear Exp. 10 <sup>-5</sup> in./in/°C	Bond Shear (Lap) PSI
Frames & Facings	Steel	485	28-30	29-35	8.5-11.0	96-460			1.0-1.8	
	Aluminum	173	7-10	6-27		610-1620			2.2-2.4	
	FRP	100-125	30-70	60-180	45-60	1.92-2.28	150-500		1.54-1.44	
Cores	Styrofoam	60	2-5.2	1.2-1.8	1.0-1.1	.12-.45	150-250			
	Urethane Foam	25-65	.001-.005	.02-1.2						
	Paper Hcomb. 1/2"	3.8								
	Nomex 3/16"	8.0						250		
	Al Hcomb. 3/16"	2.0-8.1								
	Plywood									
Adhesives	Nitrile Phenolic						GD-EXC	250-350		3500
	Vinyl Phenolic						FAIR-GOOD	225-250		4200
	Epoxy Phenolic						Poor-Fair	250-350		3400
	Epoxy						Poor-Fair	250-350		3100
	Modified Epoxy 250°						Good	250		4500
	Mod. Epoxy 350°						Good	350		3300
	Epoxy Polyamide						Good	250-350		5500
	Polyimide						Poor	250-350		3300

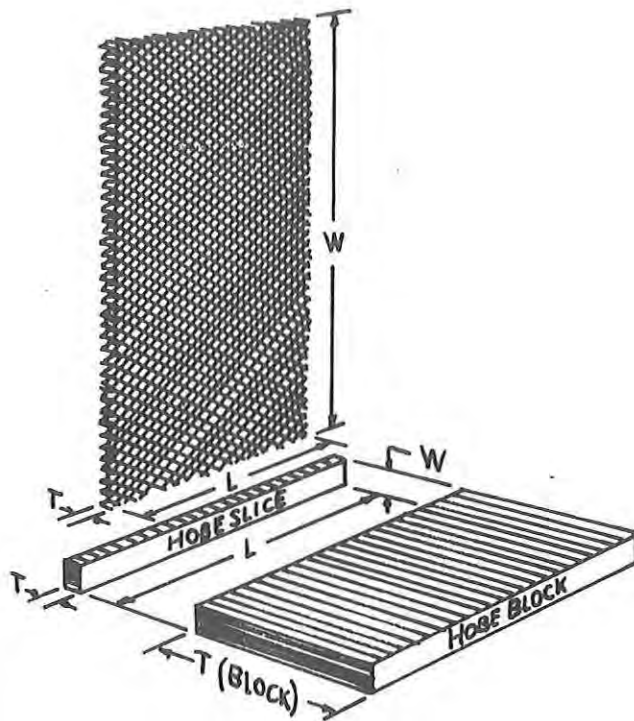

Honeycomb materials with six-sided cells

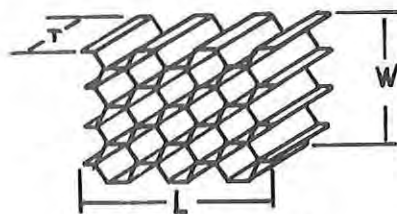

Expanded core

Figure 26. Section of Honeycomb Material

dicular to the ribbons). In considering the design of a particular sandwich panel, for example, 8' x 20' to resist environmental loading, the ply direction of the honeycomb is paramount in designing for deflection and structural properties. (For a comparative study of 8' x 20' panels of various material matrices as compared to physical parameters, see Table VIII).

Frames - Due to the high strengths required to meet the loading conditions specified by the ISO guidelines, materials which were considered initially feasible for the structural frame were steel, aluminum, and FRP. Although each of these materials presently has drawbacks which make them less than optimum, such as high maintenance for steel and lack of hardness for FRP, developments are underway which should improve overall performance of each of the mentioned materials in this application. Improved steel alloys which have self-limiting corrosion levels, such as Cor-Ten, and aluminum coated steel would greatly reduce long-run maintenance. Plastic-clad metals would not only reduce maintenance, but also somewhat reduce thermal conductivity. Carbon-fiber reinforced polyester, now quite costly, but predicted to be competitive within a few years, possesses dramatically higher tensile, compressive, and flexural moduli than glass fiber-reinforced polyester.

## Materials for Frame & Panel Technology

### Frame and Facings

- Steel
- Aluminum
- FRP

### Cores

- Polystyrene Foam
- Polyurethane Foam
- ½" Cell Paper Honeycomb
- 3/16" Cell Nomex Honeycomb
- 3/16" Cell Aluminum Honeycomb
- Plywood

### Adhesives

- Nitrile Phenolic
- Vinyl Phenolic

Epoxy Phenolic  
Epoxy  
Modified 250<sup>o</sup> Epoxy  
Modified 350<sup>o</sup> Epoxy  
Epoxy Polyamide  
Polyimide

(See Table IX. which gives the characteristics and materials of frames and panels.)

### Projection

It is easily apparent that of all the technologies examined in this contract the frame and panel systems, although somewhat limited in design configurations, offers the most complete bank of information that is readily applicable to the design of a shelter/container system. This is a result of sandwich composite development and previous SOTA shelter design and other construction uses, both beneficial to research and useful for improved comparative study. (SOTA - state-of-the-art.)

Details of all kinds have played major roles in the comparative study of the panel and frame materials. (See Tables VII, VIII & IX for reference data on composites.)

Because of the design flexibility of composite panel structures, many of the multi-modal shelter system contract requirements can be fulfilled by the maximum evaluation of material against material. A few examples follow: It would save multiple material considerations if both frame and panel facings were steel. However, periodic maintenance of steel exposed to the environment has many undesirable characteristics compared to aluminum or plastic. But then again, thermal conductivity of aluminum compared to steel or plastic has some undesirable effects that can only be negated by low conductive core materials, something that Frame & Panel Technology offers in its design flexibility. Trade-off characteristics are near endless and will be more specifically covered in the evaluation matrix.

General guidelines should be examined at this point to direct frame and panel technology towards concept application. Frame materials are probably limited to steel in the container mode, however, aluminum is a possibility. Other frame materials will probably be relegated to frame subsystems for the shelter configurations. Panels will probably be chosen for fulfillment of the design requirements and then probably according to cost and total manufacturing satisfaction. Post with single-sheet panels are likely the poorest solution, while panels with plywood or aluminum honeycomb cores are

slightly better. However, modern composites of FRP, or aluminum facings with honeycomb paper or plastic cores and foam cores offer probably the best solutions in panel technology.

In looking further in the future, some complicated composites may satisfy the multi-modal shelter system requirements better than any current frame and panel technology. Panels of laminated material combinations with cores having foamed cellular spaces may be the best solution. However, at this point no significant technology is available and the amount of material combinations is again nearly endless. New core materials may be developed that provide better adhesive peel strength. New configurations of cellular cores may displace honeycomb, plywood, and foam as premier materials.

Premanufacturing of the materials that would make a composite panel means that frame and panel processing is actually frame production and panel assembly. Although the materials may be medium to high in relative costs and processing techniques are intricate, processing equipment may be comparatively low in cost when compared to some highly automated material/process technologies.

## V. STRUCTURAL ANALYSIS

### A. Problem Definition

As was stated in the requirements of the contract, the container was to resist 40 lb/sq ft of snow load on the roof, pressure loading of 65 knot winds (22.4 lb/sq ft), 100 lb/sq ft floor loads and meet the ISO stacking and racking provisions. It was on these five, and only these five, static loading conditions that the structural design and analysis was conducted. No attempt was made at this level to define or to analyze the dynamic loading conditions imposed on the shelter container.

From additional information obtained from Natick Laboratories, it was revealed that the containers would be tested by the application of each load independently rather than all loads simultaneously. It was also made known that the racking requirement of 35 kips applied to a corner of the container in a transverse direction was not to be a planar problem resisted simply by the end frame, but rather a three-dimensional problem in which the entire container acts to resist the unsymmetrically applied force.

It is an obvious fact that in the container, the frame and panel system interact to resist all of the forces to which it will be subject. However, since the contract was one of generating a design for the year 1985 and was therefore a very preliminary analysis, it became even more difficult to estimate the structural contribution of each of the frame and panel components. This became apparent when one realized the fact that the type of connections used to join components was an unknown in a preliminary study. In addition, although the forces acting on the container were specified quite clearly, no mention was made of deflection requirements in this preliminary step. Because of the preliminary nature of this problem, it was necessary to make some rather simplifying assumptions.

With the problem defined in this manner and subject to the limitations mentioned above, it is necessary to explain the approach used in coming up with the sizes of the various members.

### B. Approach

Several alternatives could have been used to design the shelters for the static loading conditions mentioned previously. STRUDL is one alternative.

The Structural Design Language, known by the acronym STRUDL, is a series of computer programs for solving problems in structural engineering. It was developed at the M.I.T. Civil Engineering Systems Laboratory, a research unit of the department of Civil Engineering. STRUDL is capable of supplying an engineer with accurate and comprehensive technical data for a wide class of practical problems, including both framed structures and continuous mechanics problems. It also allows for mixing different element types which is precisely what we have with the container problem.

By using the computer, therefore, one could analyze the entire shelter system of beams, panels, and frames together to obtain a quite accurate approximation to the actual interaction of the members. However, the expense involved in this alternative was many times greater than that allowed for in our budget. With the six different sizes, several different loading conditions, and long list of materials, many combinations resulted which would require a tremendous amount of computer time and expense. A further limitation is the fact that a computer analysis is only as accurate as the information it receives. For many of the new materials, properties were either vague or nonexistent. In addition, this is a preliminary analysis, and decisions will be made at this level not requiring tremendously accurate results. Because of this, the STRUDL alternative became infeasible.

Another alternative was to do the entire analysis by hand. As mentioned previously, it becomes difficult to estimate the support given by each of the members and their interaction, especially since the type of connecting device and deflection requirements are unknown. Simplifying assumptions could be made, and the space framework could be analyzed separate from the panels or plates. However, a stress analysis of a statically indeterminate space framework becomes quite tedious and complicated, especially since the loading is unsymmetrical and involves torsional as well as shear and bending stresses.

The alternative of all hand calculations becomes more dismal when one considers the fact that there are several different sizes, loading conditions, and materials to consider. Because of this, a third alternative was adopted.

STRUDL was mentioned previously as being too expensive to use. However, the major cost involved was for the time consuming continuous mechanics portion and not the frame analysis. As it turned out, a frame analysis could

be conducted on the computer quite accurately, quickly, and inexpensively. The alternative used was a combination of the two previous alternatives. The frame design was calculated by computer analysis, and the panels or floors were designed by hand.

### C. Actual Design - Frame

The frame design was carried out on the computer by successive approximations. The three-dimensional frame structure was composed of slender, linear members, which were represented by properties along a centroidal axis. The analysis used was a linear, elastic, static, small displacement analysis, which treats joint displacements as unknowns. As can be seen from the computer printout (Appendix I), the geometry of the frame was supplied by giving the coordinates of each joint, and the joint number at each end of the member. Additional information supplied to the computer was the loading conditions, material properties, and member properties. From this information, the forces and moments acting on the joints and members could be obtained.

Several simplifying assumptions had to be made in this portion of the analysis. First, to account for the dead load even though the density or thickness of the roofing material was not determined yet, a snow load of 45 lb/sq ft instead of 40 lb/sq ft was used. Also, since loadings could only be applied on joints or along members in the frame analysis, estimates of load transference had to be made.

Once this was input, one could obtain the forces acting on each member and joint from each loading condition or loading combinations. By taking the most severe condition and not permitting buckling or the allowable stresses to be exceeded, the design of each member of the frame was obtained. The allowable stresses used in each type of framing material are shown in Table X. Sample calculations appear in the appendix along with other material properties used throughout the design. The figures in the table give approximately 1.5 safety factor on yield stress.

Tables XI, XII, XIII and XIV, contain the summary of the frame analysis. Each table has member sizes for five different materials and for 20', 10' and 6.67' frames. Frame member A refers to the columns, B to the longitudinal beams to span the 20', 10', and 6.67' dimension, and C to the end beams spanning the 8' dimension, as is shown in Figure 27.

TABLE X. ALLOWABLE STRESS IN FRAMING MATERIALS

Material	Allowable Flexure Stress	Allowable Shear Stress
Steel	24	21
Aluminum	19	12
FRP		
Woven	27.6	12.0
Unidirectional	21.7	10.0
Roving	20.6	10.0

All in ksi units.

The differences in Tables XI, XII, XIII, and XIV are reflected in two variables: the loads applied and if rack resisters were added. Rack resisters are illustrated in Figure 28. As one can see from Table XIII, with no sort of rack resisters, the bending moments become very large and, hence, the sizes are quite large. Therefore, a frame analysis with rack resisters was undertaken for two reasons: first, to estimate the rack resisting ability of strong panels and second, to calculate sizes when rack resisters were actually placed in the final design.

The other variable used in Tables XI, XII and XIII was the type of loading. The ISO racking and stacking requirements had to be resisted by the shelter core and the environmental loads by the expanded portions of the shelters.

One may not be certain, at this stage, which of Tables XI through XIV should be used to obtain the correct size of the frame to be used. The correct size should be determined by the application and the material used in the panel. If the frame is a nonexpandable, or the core of an expandable, Table XI or XIII should be used. If the frame is the non-core expanded portion, Tables XII or XIV should be used. Rack resisters should be used only if the panel material is estimated to be of insufficient strength to prevent excess deflection caused by the ISO racking requirement, which causes the large bending moments. The frames used will be more explicitly defined in the following sections.

TABLE XI. FRAME SIZES FOR FRAME NO. 1

Material	Frame Member	Frame Lengths		
		6-2/3'	10'	20'
Steel	A	4 x 4 x .375	4 x 4 x .375	4 x 4 x .375
	B	3.5 x 3.5 x .25	3 x 3 x .1875	3.5 x 3.5 x .25
	C	4 x 4 x .25	3.5 x 3.5 x .25	3.5 x 3.5 x .25
Aluminum	A	4 x 4 x .5	4 x 4 x .5	4 x 4 x .5
	B	(4 x 4 x .25) (5 x 3 x .25)	3.5 x 3.5 x .1875	(4 x 4 x .25) (5 x 3 x .1875)
	C	4 x 4 x .3125	4 x 4 x .25	4 x 4 x .25
FRP Woven	A	5 x 5 x .3125	5 x 5 x .3125	5 x 5 x .3125
	B	3.5 x 3.5 x .25	3 x 3 x .1875	3.5 x 3.5 x .1875
	C	4 x 4 x .1875	3.5 x 3.5 x .25	3.5 x 3.5 x .1875
FRP Unidirectional	A	5 x 5 x .375	5 x 5 x .375	5 x 5 x .375
	B	4 x 4 x .25	3 x 3 x .25	4 x 4 x .25
	C	4 x 4 x .25	4 x 4 x .25	3.5 x 3.5 x .25
FRP Roving	A	5 x 5 x .5	5 x 5 x .5	5 x 5 x .5
	B	4 x 4 x .25	3 x 3 x .25	4 x 4 x .25
	C	4 x 4 x .3125	4 x 4 x .25	3.5 x 3.5 x .25

Note: Unless otherwise Noted, All Dimensions Given in Inches  
 Characteristics of Frame #1: ISO Loading Conditions  
 Rack Resistors

TABLE XII. FRAME SIZES FOR FRAME NO. 2

Material	Frame Member	Frame Lengths		
		6-2/3'	10'	20'
Steel	A	2 x 2 x .1875	2 x 2 x .25	3 x 3 x .25
	B	2 x 2 x .1875	(3 x 3 x .1875) (3 x 2 x .1875)	3.5 x 3.5 x .25
	C	2 x 2 x .1875	2 x 2 x .1875	2 x 2 x .1875
Aluminum	A	3 x 2 x .1875	3 x 2 x .1875	3.5 x 3.5 x .25
	B	2 x 2 x .1875	3 x 2 x .1875	(4 x 4 x .25) (5 x 3 x .1875)
	C	2 x 2 x .1875	2 x 2 x .1875	2 x 2 x .1875
FRP Woven	A	2 x 2 x .1875	2 x 2 x .1875	3 x 3 x .25
	B	2 x 2 x .1875	2 x 2 x .25	3.5 x 3.5 x .18
	C	2 x 2 x .1875	2 x 2 x .1875	2 x 2 x .1875
FRP Unidirectional	A	2 x 2 x .25	2 x 2 x .25	3.5 x 3.5 x .1875
	B	2 x 2 x .1875	3 x 3 x .1875	4 x 4 x .1875
	C	2 x 2 x .1875	2 x 2 x .1875	2 x 2 x .1875
FRP Roving	A	2 x 2 x .25	3 x 3 x .1875	3.5 x 3.5x .187
	B	2 x 2 x .1875	3 x 3 x .1875	4 x 4 x .1875
	C	2 x 2 x .1875	2 x 2 x .1875	2 x 2 x .1875

Note: Unless otherwise noted, all dimensions given in inches  
 Frame #2 designed with environmental loads & rack resisters.

TABLE XIII. FRAME SIZES FOR FRAME NO. 3

Material	Frame Member	Frame Lengths		
		6-2/3'	10'	20'
Steel	A	(10 x 8 x .5) (12 x 6 x .5)	(10 x 8 x .5) (12 x 6 x .5)	(10 x 8 x .5) (12 x 6 x .5)
	B	5 x 5 x .375	5 x 5 x .5	6 x 6 x .5
	C	6 x 6 x .375	6 x 6 x .375	(7 x 5 x .375) (6 x 6 x .375)
Aluminum	A	(6 x 12 x .5) (10 x 10 x .5)	(10 x 10 x .5) (12 x 8 x .5)	(10 x 10 x .5) (12 x 8 x .5)
	B	6 x 6 x .5	7 x 7 x .5	7 x 7 x .5
	C	6 x 6 x .5 8 x 4 x .5 12 x 2 x .3125	6 x 6 x .5 8 x 4 x .5 12 x 2 x .3125	(8 x 4 x .5) (6 x 6 x .5)
FRP Woven	A	(10 x 6 x .5) (10 x 8 x .375)	10 x 6 x .5	12 x 6 x .375
	B	6 x 6 x .375	6 x 6 x .5	7 x 7 x .5
	C	6 x 6 x .3125	6 x 6 x .3125	6 x 6 x .3125
FRP Unidirectional	A	(10 x 8 x .5) (12 x 6 x .5)	(10 x 8 x .5) (12 x 6 x .5)	(12 x 6 x .5) (12 x 8 x .375)
	B	6 x 6 x .5	7 x 7 x .5	7 x 7 x .5
	C	6 x 6 x .375	6 x 6 x .375	6 x 6 x .5
FRP Roving	A	(10 x 8 x .5) (12 x 6 x .5)	12 x 6 x .5	12 x 8 x .5
	B	6 x 6 x .5	7 x 7 x .5	7 x 7 x .5
	C	6 x 6 x .5	6 x 6 x .375	6 x 6 x .5

Note: Unless otherwise noted, all dimensions given in inches.  
Frame #3 designed with ISO loads; no rack resisters

TABLE XIV. FRAME SIZES FOR FRAME NO. 4

Material	Frame Member	Frame Lengths		
		6-2/3'	10'	20'
Steel	A	2 x 2 x .25	3 x 3 x .1875	4 x 4 x .25
	B	2 x 2 x .1875	3 x 2 x .1875	3.5 x 3.5 x .25
	C	2 x 2 x .1875	2 x 2 x .1875	2 x 2 x .1875
Aluminum	A	(3 x 3 x .1875) (3 x 2 x .1875)	(3 x 3 x .1875) (4 x 2 x .1875)	4 x 4 x .3125
	B	2 x 2 x .1875	3 x 2 x .1875	(4 x 4 x .25) (5 x 3 x .25)
	C	2 x 2 x .1875	2 x 2 x .1875	2 x 2 x .1875
FRP Woven	A	2 x 2 x .1875	3 x 2 x .1875	3.5 x 3.5 x .25
	B	2 x 2 x .1875	2 x 2 x .25	3.5 x 3.5 x .25
	C	2 x 2 x .1875	2 x 2 x .1875	2 x 2 x .1875
FRP Unidirectional	A	3 x 2 x .1875	3 x 2 x .25	4 x 4 x .25
	B	2 x 2 x .1875	3 x 2 x .1875	4 x 4 x .25
	C	2 x 2 x .1875	2 x 2 x .1875	2 x 2 x .1875
FRP Roving	A	3 x 2 x .1875	3 x 3 x .1875	4 x 4 x .25
	B	2 x 2 x .1875	3 x 2 x .1875	4 x 4 x .25
	C	2 x 2 x .1875	2 x 2 x .1875	2 x 2 x .1875

Note: Unless otherwise noted, all dimensions given in inches  
 Frame #4 designed with Environmental Loads; No Rack Resistors

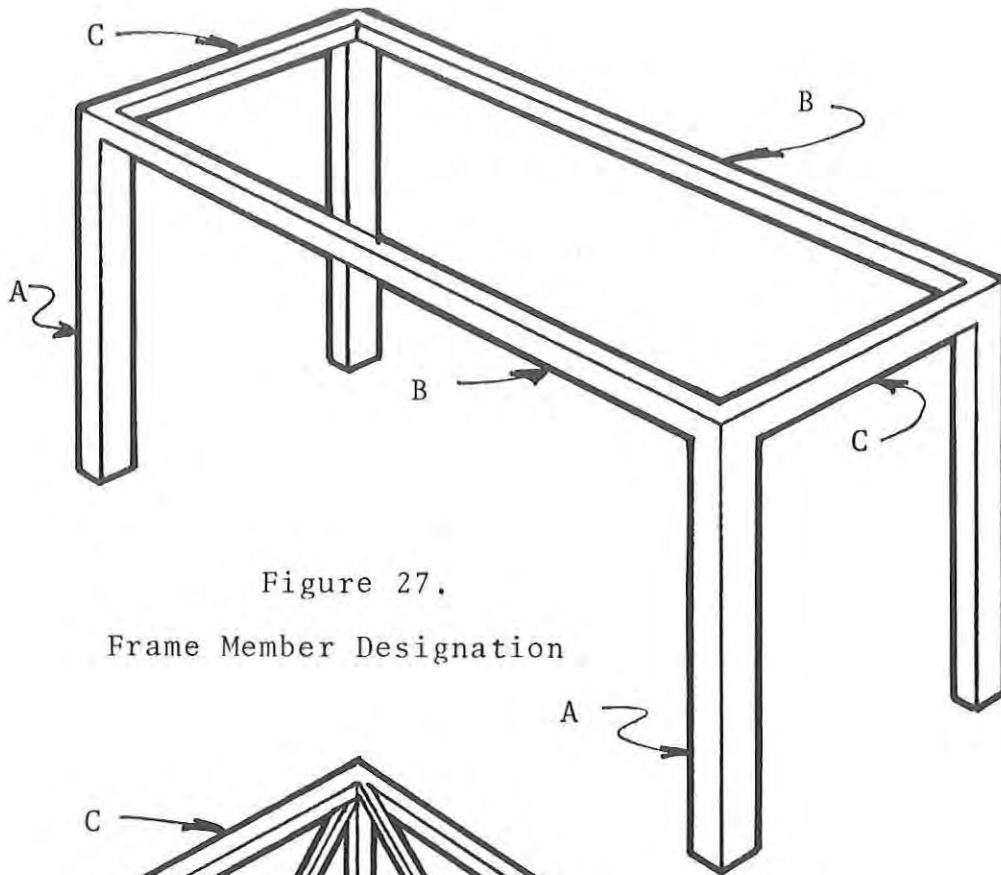

Figure 27.  
Frame Member Designation

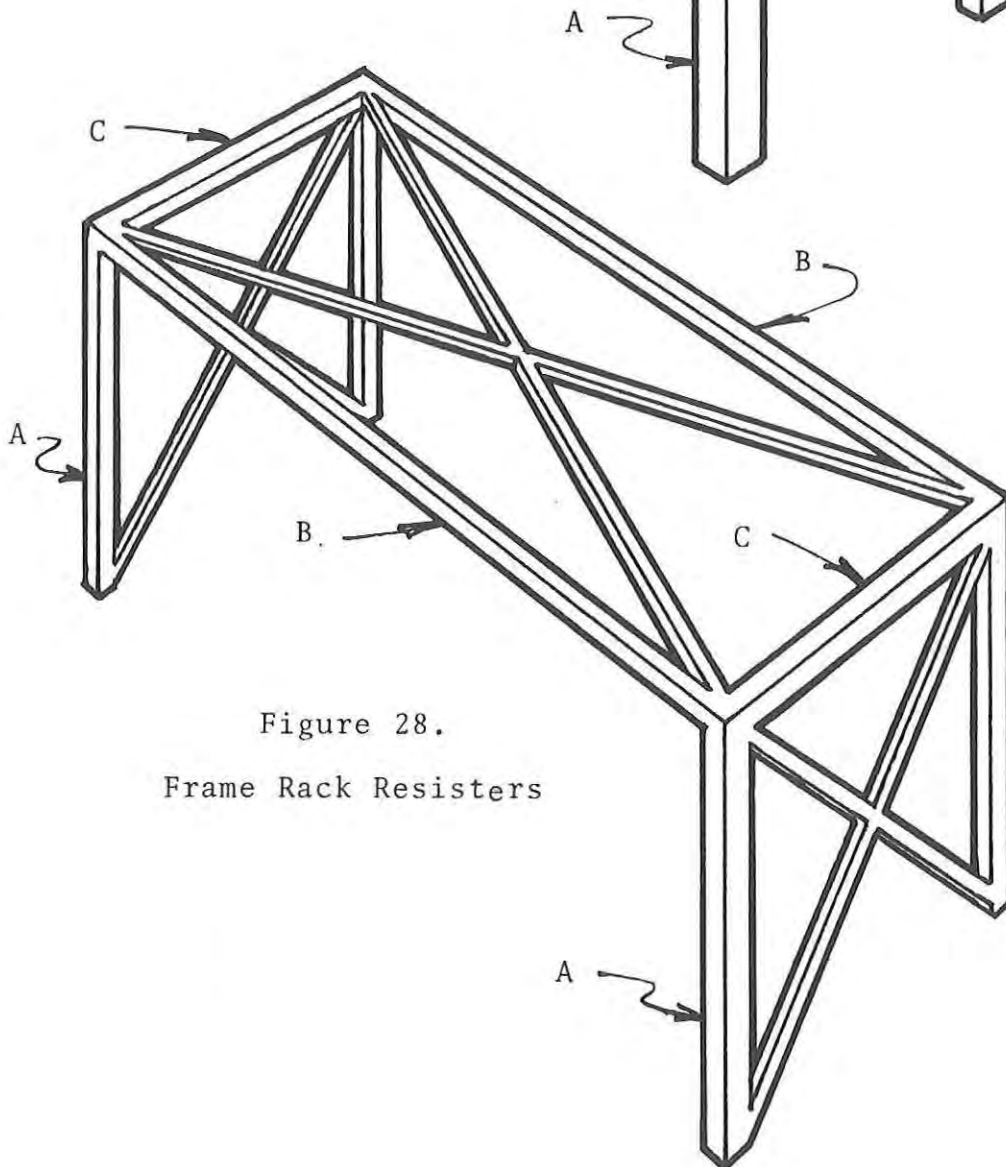

Figure 28.  
Frame Rack Resisters

A frame material study was completed to show the volume savings of material used in the frame with the addition of rack resisters. As Table XV shows, the material savings is considerable when one uses rack resisters in the heavily loaded applications.

TABLE XV. FRAME MATERIAL STUDY

Material	Rack Resisters	Without Rack Resisters	% Increase
FRP-Woven			
20'	5,080 in <sup>3</sup>	11,750 in <sup>3</sup>	131.0%
10'	4,321 in <sup>3</sup>	9,090 in <sup>3</sup>	110.0%
6-2/3'	4,207 in <sup>3</sup>	7,290 in <sup>3</sup>	73.0%
Steel			
20'	4,563 in <sup>3</sup>	12,475 in <sup>3</sup>	170.0%

Note: End Frame Rack Resisters are 1.5 in<sup>2</sup> in cross-sectional area;  
Roof Frame Rack Resisters are 1.0 in<sup>2</sup> cross-sectional area.

Comparison: Material Volume Required - Rack Resisters  
Versus No Rack Resisters With ISO  
Loading

D. Other Design Considerations

Since this effort was a preliminary study and not a "detailed" design, once the frame design was completed the only remaining design consideration was the material to go around the frame. Each material process produced panels which differed from each other structurally and, for that reason, were handled separately, except for the thermoformed and laminated materials which were designed in the same manner.

## Thermoforming

The end result of the thermoformed materials (see Table XVI.), was a sandwich panel configuration, very similar to the laminated materials shown in Table XVII. Because of this fact, both were designed in the same manner by use of MIL-HDBK-23A, a publication of the Department of Defense called "Structural Sandwich Composites". The assumptions made in using MIL-HDBK-23A were that the panels were simply supported, and that the deflections were limited to less than one-half the thickness of the panel. As mentioned previously, the type of connections between the frame and the panels was unknown, and one could be conservative in assuming simply supported, since deflections are five times greater than panels with fixed edges.

Another simplifying assumption was that the frame resisted all the racking and stacking loads, and therefore the panels only had to resist the environmental loads. With this assumption, sizes could be taken directly from Chapter 9 of MIL-HDBK-23A, and because of this, no sample calculations are shown in the appendix.

Taking a closer look at Tables XVI and XVII, "t" stands for the facing thickness and "d" for the overall panel thickness. In all cases except one, the facing thicknesses on each side of the core were equal. The roof panels shown in both tables were subject to a snow load of 40 lbs/sq ft, and the side and end panels resisted the wind loading. The dimensions shown are for every possible configuration under consideration.

The final design can be obtained for the thermoformed or laminated shelter by combining sizes shown in Tables XVI or XVII with the frames shown in Tables XI or XIII, if the shelter is subject to ISO loadings (the nonexpandable or the core of the expandable). The final design can also be obtained by combining sizes shown in Tables XVI or XVII with the frames shown in Tables XII or XIV for the non-core portion of the expandable shelters.

## Filament Winding

The next process undertaken was that of filament winding. Filament winding presented some rather unique problems in that the process would result in a four-sided enclosed tubular shelter that could either be wound longitudinally or transversely (see Figure 29.). It was also unique in the fact that this process could be

TABLE XVI. THERMOFORMED PANEL CONFIGURATIONS

Thermoformed Panel Configuration	Dimensions	ROOF PANELS						SIDE & END PANELS				
		Panel Dimensions						Panel Dimensions				
		6 $\frac{2}{3}$ x4	6 $\frac{2}{3}$ x8	10x4	10x8	20x4	20x8	6 $\frac{2}{3}$ x8	8x4	8x8	10x8	20x8
FRP Skins PE Foam Equal Skins	t	.07	.08	.07	.13	.08	.14	.08	.05	.08	.10	.13
	d	.69	.84	.75	1.37	.80	1.54	.82	.55	.96	1.05	1.37
Polycarbonate Skins; Ure- thane Foam Equal Skins	t	.12	.17	.12	.23	.12	.23	.15	.10	.17	.18	.21
	d	1.22	1.84	1.26	2.43	1.32	2.53	1.59	1.05	1.79	1.90	2.22
ABS Equal Skins	t	.17	.25	.18	.32	.19	.33	.21	.15	.23	.24	.30
	d	1.79	2.75	1.90	3.47	2.00	3.58	2.28	1.58	2.53	2.68	3.27
FRP-Polyure- thane Skins Urethane Foam FRP=t <sub>1</sub> Purethane=t <sub>2</sub> Unequal Skins	t <sub>1</sub>	.03	.04	.03	.04	.03	.05	.03	.02	.03	.03	.05
	t <sub>2</sub>	.12	.17	.12	.17	.12	.24	.13	.09	.15	.16	.21
	d	1.17	1.68	1.21	1.72	1.27	2.54	1.35	.95	1.53	1.63	2.14

Note: Panel Dimension are in Feet, other dimensions in Inches

t = Facing Thickness (combined)

d = Total Panel Thickness

TABLE XVII. LAMINATED PANEL CONFIGURATIONS

Laminated Materials	Dimensions	ROOF PANELS Panel Dimensions						SIDE & END PANELS Panel Dimensions				
		6 $\frac{2}{3}$ x4	6 $\frac{2}{3}$ x8	10x4	10x8	20x4	20x8	6 $\frac{2}{3}$ x8	8x4	8x8	10x8	20x8
Al/Foam/Al Polystyrene	t	.05	.06	.06	.10	.06	.111	.06	.07	.07	.08	.10
	d	.53	.65	.58	1.05	.62	1.17	.63	.68	.73	.80	1.05
Polyurethane	t	.06	.07	.07	.12	.07	.13	.07	.05	.08	.09	.12
	d	.62	.76	.68	1.23	.73	1.38	.74	.49	.86	.95	1.23
FRP/Foam/FRP Polystyrene	t	.07	.08	.07	.13	.08	.14	.08	.05	.09	.01	.13
	d	.67	.82	.73	1.33	.78	1.49	.80	.53	.93	1.02	1.33
Polyurethane	t	.07	.08	.08	.13	.08	.15	.08	.06	.09	.01	.13
	d	.72	.87	.78	1.42	.83	1.59	.85	.57	.99	1.08	1.43
Steel/Foam/Steel Polystyrene	t	.04	.05	.04	.07	.05	.08	.05	.03	.05	.06	.07
	d	.39	.47	.42	.76	.45	.85	.46	.31	.53	.59	.76
Polyurethane	t	.04	.05	.05	.08	.05	.09	.05	.04	.06	.07	.08
	d	.43	.53	.47	.86	.51	.96	.52	.35	.60	.67	.86
Al/Honeycomb/Al 3 16" low density	t	.05	.06	.05	.09	.06	.10	.06	.04	.07	.07	.09
	d	.50	.61	.55	.99	.58	1.11	.60	.40	.70	.76	.99
3 16" high density	t	.05	.06	.05	.09	.06	.10	.06	.04	.07	.07	.09
	d	.48	.59	.52	.95	.56	1.06	.57	.38	.67	.73	.95
FRP/Honeycomb/FRP 1/2" Cell Paper	t	.06	.07	.07	.12	.07	.125	.07	.05	.08	.09	.12
	d	.62	.76	.68	1.23	.73	1.38	.74	.49	.86	.95	1.23
3 16" Cell Tuf- comb	t	.06	.07	.06	.11	.07	.12	.07	.05	.08	.09	.11
	d	.60	.73	.65	1.18	.69	1.32	.71	.47	.83	.91	1.18

Note; Panel Dimensions are in Feet, Other dimensions in Inches  
t = Facing Thickness (combined); d = Total Panel Thickness

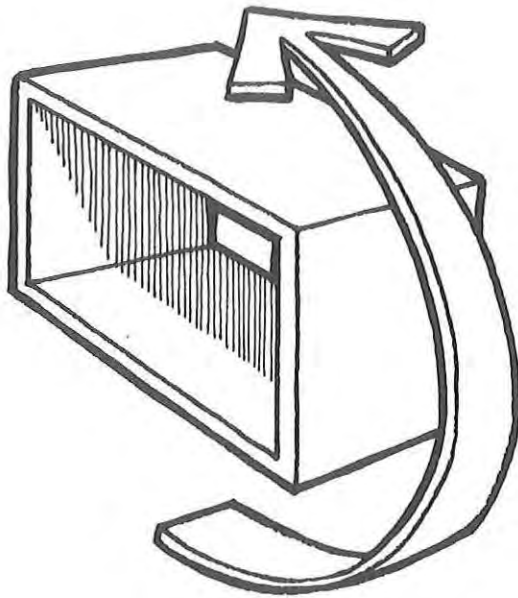

Shelter Longitudinally Wound

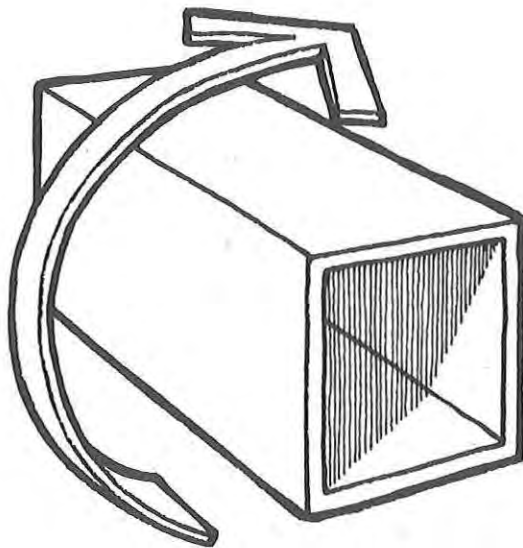

Shelter Transversely Wound

Figure 29. Filament Winding Configurations

carried out with or without an enclosed frame. The design, therefore, had to allow for all these considerations. Sample calculations are shown in the Appendix.

For the process without an enclosed frame, the ISO stacking and racking provisions still had to be met. For the stacking requirement of 108k, an assumption was made that a section of material the length of an ISO corner ( $6\frac{1}{2}$ " ) would have to withstand the load both from a compressive and a buckling standpoint. It was also assumed that  $\frac{1}{2}$  of the side of a transversally wound shelter would have to resist the bending caused by the racking load in a 20-foot shelter,  $\frac{3}{4}$  of the side in the 10-foot shelter, and all of the side in the 6- $\frac{2}{3}$ -foot shelter. Because of the large compression loadings and the large bending moments, Table XVIII indicates that the facing thicknesses (t) are three times the facing thicknesses in shelters with frames and rack resisters, and about  $1\frac{1}{2}$  times as large for frames without rack resisters.

Also noticeable from Table IX. is that if no edge beams (beam B of Figure 27.) are used in the longitudinally wound shelter, the overall thickness (d) must be increased to offset the increased deflection which results.

The final design for filament winding is self-explanatory from Table XVIII. If no frame is used, either of the first two columns of Table IX. can give the sizes. If a frame is used, the size of which can be obtained from Table XI through XIII depending upon the loading condition, the remaining columns of Table XVIII provide the appropriate sizes.

### Injection Molding

Injection molded materials were the next design consideration. The panels which resulted from this process had cross-sections of varying density in the thickness direction. The highest density appeared at the surface of the panels, with the lowest density in the center. The panels resembled sandwich composites, but had no definite boundaries between facings and cores.

The properties for these materials were listed as an average value for the entire cross-section, and for design considerations, one treated the materials as having uniform properties throughout. Once again, the panels were designed to withstand only the environmental loadings, and were assumed to be simply supported. The actual stresses were kept below the allowable

TABLE XVIII. FILAMENT WINDING FACING THICKNESSES

Shelter Length	Dimensions	Without Frame Or Rack Resistors		End Frame With Rack Resistors		End Frame Without Rack Resistors	
		With Edge Beams	Without Edge Beam	With Edge Beam	Without Edge Beam	With Edge Beam	Without Edge Beam
<u>20' Shelter</u>							
Longitudinal Wind	t	.45	.45	.15	.15	.16	.16
Ends	d	1.50	1.50	1.50	1.50	1.55	1.55
Roof	d	1.50	3.00	1.50	5.00	1.55	5.10
Transversal Wind	t	.50	.50	.15	.15	.35	.35
Sides	d	1.75	1.75	1.40	1.40	1.55	1.55
Roof	d	1.75	1.75	1.60	1.60	1.55	1.55
<u>10' Shelter</u>							
Longitudinal Wind	t	.45	.45	.15	.15	.16	.16
Ends	d	1.50	1.50	1.50	1.50	1.55	1.55
Roof	d	1.50	2.00	1.50	2.50	1.55	2.60
Transversal Wind	t	.55	.55	.15	.15	.40	.40
Sides	d	1.85	1.85	1.40	1.40	1.60	1.60
Roof	d	1.85	1.85	1.60	1.60	1.60	1.60
<u>6-2/3' Shelter</u>							
Longitudinal Wind	t	.45	.45	.15	.15	.16	.16
Ends	d	1.50	1.50	1.50	1.50	1.55	1.55
Roof	d	1.50	1.50	1.50	1.50	1.55	1.55
Transversal Wind	t	.57	.57	.15	.15	.40	.40
Ends	d	1.90	1.90	1.40	1.40	1.60	1.60
Roof	d	1.90	1.90	1.60	1.60	1.60	1.60

Note: Rack Resistors only in 8' x 8' End Panels where applicable.

Edge Beams appear only in the length direction where applicable, and are of the following sizes: 20' shelter = 4 x 4 x .25"; 10' Shelter = 3 x 2 x .1875"; 6-2/3' Shelter = 2 x 2 x .1875"

All dimensions in Inches

stresses, and the deflection was limited to less than one-half the thickness. The formulas used in the design were the following:

$$\text{Max } y = \alpha \frac{wb^4}{Et^3} \quad (\text{deflection})$$

$$\text{Max } s = \beta \frac{wb^2}{t^2} \quad (\text{stress})$$

where  $\alpha$  and  $\beta$  are defined in Table XIX.

TABLE XIX. DEFLECTION & STRESS OF A SIMPLY SUPPORTED PANEL

$\frac{a}{b}$	1	1.2	1.4	1.6	1.8	2	3	4	5	$\infty$
$\beta$	.287	.376	.453	.5172	.5688	.6102	.7134	.741	.7476	.75
$\alpha$	.044	.062	.077	.0906	.1017	.111	.1335	.14	.1417	.142

where a and b are the dimensions of the panel

$\alpha$  and  $\beta$  are constants.

The thicknesses of the panels for every configuration under consideration are shown in Table XX. It became known that for panel thicknesses greater than .25", material savings could be obtained by the use of ribs, even though the overall dimension was increased slightly. The thicknesses of panels with ribs are also shown in Table XX. Figure 30 shows the cross-section of a ribbed panel, and Table XXI points out the material savings using ribs in the 20' x 8' roof panel. Calculations for the panel thickness and for material savings appear in the appendix.

The final design of injection molded shelters can be obtained by combining the sizes shown in Table XX with the frames of Table XI through XIV, depending on the loading and whether rack resisters are used.

TABLE XX. INJECTION MOLDED PANEL CONFIGURATIONS

Injection Molded Materials	ROOF PANELS Panel Dimensions						SIDE & END PANELS Panel Dimensions					
	6 $\frac{2}{3}$ x4	6 $\frac{2}{3}$ x8	10x4	10x8	20x4	20x8	6 $\frac{2}{3}$ x8	8x4	8x8	10x8	20x8	
High Density Polyethylene	Ribs-With	1.54	2.34	1.60	3.10	1.67	3.20	2.02	1.33	2.26	2.4	2.80
	Without	1.30	1.96	1.35	2.60	1.28	2.69	1.70	1.12	1.91	2.02	2.36
Polypropylene	Ribs-With	1.54	2.34	1.60	3.10	1.67	3.20	2.02	1.33	2.26	2.40	2.80
	Without	1.30	1.96	1.35	2.60	1.28	2.69	1.70	1.12	1.91	2.02	2.36
Urethane Structural Foam	Ribs-With	1.30	1.97	1.35	2.60	1.41	2.70	1.70	1.12	1.92	2.04	2.38
	Without	1.16	1.75	1.20	2.31	1.25	2.40	1.51	1.00	1.70	1.80	2.10

Note: Panels with ribs have rib spacing of 6.0" and rib thickness of .25".  
Panel Dimensions in Feet; Other Dimensions in Inches

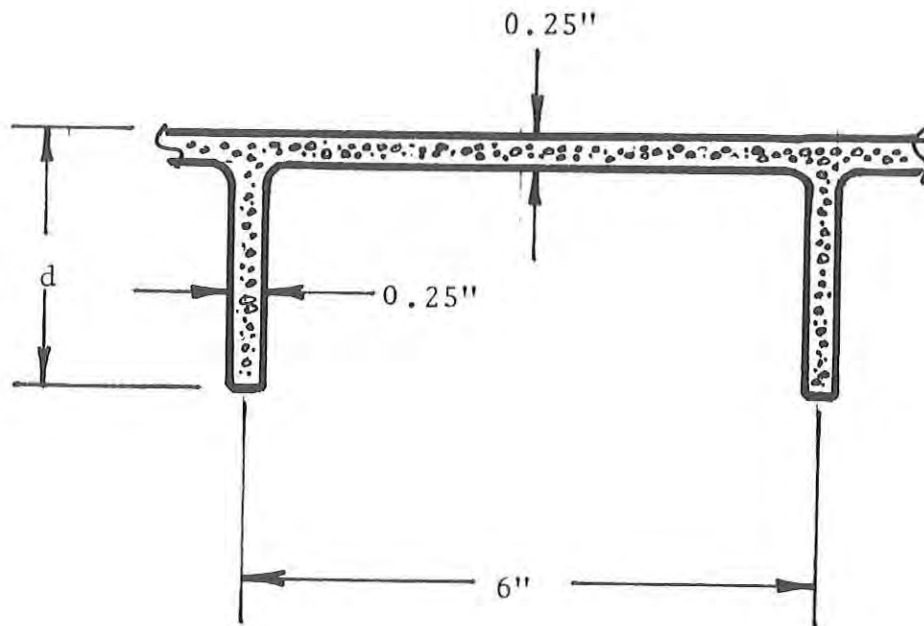

Figure 30. Cross-Section of Ribbed Panel

TABLE XXI. INJECTION MOLDED MATERIAL SAVINGS USING MOLDED RIBS

Injection Molded Materials	Without Ribs a.	With Ribs b.	Material Savings With Ribs a/b
High Density Polyethylene d.	2.69"	3.2"	725%
Polypropylene d.	2.69"	3.2"	725%
Urethane Structural Foam d.	2.4"	2.7"	680%

Note: Thickness of panels without ribs can be approached by increasing rib thickness or by decreasing rib spacing.

## Rotomolding

The final process consideration is rotomolding. All the processes up to this one had a sandwich-like cross-section, with the most dense material closest to the surface. The thin spaced facings provided nearly all of the bending rigidity to the construction. The core spaced the facings and transmitted shear between them so that they were effective about a common neutral axis. In rotomolding, however, the stronger, more dense material appears on the inside of the panel. A punched metal plate or webbing is placed within approximately a 1/8" crosslinked polyethylene coating. The cross-linked polyethylene has an elastic modulus of  $5 \times 10^5$  psi and a flexure strength of 6,000 psi, compared to aluminum, which has an elastic modulus of  $10 \times 10^6$  psi and a flexure strength of 40,000 psi.

The panel is thus structurally inefficient as the crosslinked polyethylene offers little to resist the loading. As a result of this fact, the punched plate must resist most of the loading and prevent excess deflection, resulting in rather large thicknesses and weights. From a test conducted by The Boeing Company, an estimate of the aluminum plate thickness was made for the 20' x 8' roof panel, and was found to be .3" thick (see Appendix). Because of the thickness and the weight involved, rotomolding was ruled to be one of the less desirable processes.

## Floor Panels

The last structural consideration undertaken was that of the floor panels. As can be seen from Table XXII, the four best material combinations of sandwich construction were designed for 100 lb/sq ft. The assumptions made were that the floors were simply supported, and that the deflection was limited to approximately 1/4 the thickness. "t" once again indicates the facing thickness and "d" the overall thickness. The design was carried out by using MIL-HDBK-23A.

It was also assumed that any floor sandwich panel could be used with any process mentioned above. The 100 lb/sq ft was the only design loading, because other shipping and loading requirements were to be handled by the pallets which are discussed more thoroughly in the transport interface section.

TABLE XXII. FLOOR PANEL MATERIALS/CONFIGURATIONS

Sandwich Panel Materials		$6\frac{2}{3}' \times 8'$	$10' \times 8'$	$20' \times 8'$
Steel/Foam/Steel	t	.105"	.125"	.154"
	d	1.16"	1.38"	1.70"
FRP/Honeycomb/FRP	t	.152"	.182"	.221"
	d	1.68"	2.01"	2.44"
Al/Honeycomb/Al	t	.12"	.142"	.173"
	d	1.32"	1.57"	1.91"
FRP/Foam/FRP	t	.158"	.188"	.23"
	d	1.74"	2.07"	2.53"

Beams appear along edges of floor panels in the following sizes:

$20' \times 8'$	$3\frac{1}{2} \times 3\frac{1}{2} \times .25$	Length
	$3 \times 3 \times .25$	Width
$10' \times 8'$	$3\frac{1}{2} \times 3\frac{1}{2} \times .25$	Length
	$3 \times 3 \times .25$	Width
$6\frac{2}{3}' \times 8'$	$3 \times 2 \times .1875$	Length
	$3 \times 2 \times .25$	Width

Note: Deflection on panels was limited to .2h.

## VI. DESIGN CONFIGURATIONS

The Design Configuration section deals with: 1.) those factors to be considered in arriving at the physical configurations in the multi-modal shelter system; 2.) the presentation of a system of design alternatives; and 3.) descriptions outlining several alternative configurations.

### A. Requirements Review

The following is a summary and discussion of the factors which were considered configurational requirements of the multi-modal shelter system.

1. Size Requirements - Two types (expandable and non-expandable) of shelter containers in each of three lengths (6-2/3', 10', and 20') are required. Height and width in transport mode are a standard 8' x 8'. An inside height of 7' must be maintained. Optimum expanded shelter width is 24', an expansion ratio of 3:1.

It is thus necessary to visualize the multi-modal shelter system as six separate shelter containers of which each performs in a somewhat different manner. From this point, uniformities within various combinations of individual shelter-container sizes and types, as well as across-the-board commonalities, are sought.

2. Standardization - Once common interrelationships of the six shelters have been discovered, a total system of shelter components may be visualized. Extraneous components and redundancy should be eliminated in order to achieve a minimum number of system components. There are several methods to achieve degrees of standardization within the system, such as:

- a. Interchangeable Parts - Wherever possible, components may be designed to serve not only one shelter-container type, but also others in the system. Examples might be common access doors, jack standards, or mechanical accessory attachment methods.
- b. Multi-functional Parts - One component may be designed to serve more than one function, e.g., a panel may be designed to be equally efficient as both a roof panel and a wall panel.

- c. Consolidated Parts - Certain component combinations may be joined to form a single shelter system component.
  - d. Modular Parts - Modular components may be designed to fulfill all of the dimensional requirements by joining multiples of modules together, e.g., a nominal 3-1/3' long panel may be used 2 times, 3 times, and 6 times for 6-2/3', 10', and 20' lengths, respectively.
  - e. Stock Material - Stock material may be produced which may be cut into halves, thirds, or other subdivisions of the largest component in a multiple system and easily prepared (with necessary fittings) for use where needed, e.g., a stock 20' x 8' floor panel may become two 10' x 8' or three 6-2/3' x 8' floor panels with little or no wasted material. Labor required at this point would be required in any case to attach close-outs and hardware.
  - f. Manufacturing Process Versatility - One manufacturing process may be selected to produce most components (especially large, somewhat similar components). Maintaining manufacturing equipment and the various tooling on standby, in order to produce additional and replacement units as required, may be preferred in some cases to maintaining a large inventory of components.
  - g. Tool Versatility - Component molds may be designed to change over with little modification from producing one specific component to another. For example, three sizes of filament-wound shelter container cores may be produced on the same facility merely by altering the dimensions of the mandrel.
3. Expandability Function - The MMSS requires three shelter lengths (6-2/3', 10', 20') which are capable of expanding width-wise to approximately 24'; a ratio of 3 to 1. When in transport (unexpanded) mode, the shelter containers should also be capable of containing all necessary functional equipment, as well as storing any additional equipment. Access should be provided in both shelter (expanded) mode and in transport mode, therefore, location of cargo and/or personnel doors is a prime consideration when developing expansion configurations.

Basic methods of expansion which have been considered are as follows:

- a. Hinged Panels
- b. Telescoping (sliding) modules
- c. Folding (accordion) panels
- d. Fabric
- e. Inflatables

Several methods of achieving 3:1 expandability have been evolved either directly from the above or by combining these basic methods to form hybrid expandable configurations which also fulfill MMSS requirements. Fabric and inflatable expandables have been judged poor candidates for the MMSS due to lower probability of resisting environmental loads, greater maintenance required, and less desirable thermal properties than would be possible using the other three methods. A major design consideration with regards to expanding modules is their suitability for interchangeability, multi-functionality, modularity, etc. discussed under the heading (2.) Standardization above.

Expanding components must be designed to be geometrically feasible in transport mode, during expansion sequence, in shelter mode and back to transport mode. Various secondary mechanical systems, such as hinges, assistance devices (deadmen, winches, etc.), tracks, roller bearings, locking devices, support and leveling devices, and so forth, are usually required. Attaching these sub-components to major components, which are in turn joined together, eliminates the eventuality that lost, loose parts would render a shelter container useless.

Erection expanding sequences should be performable with ease in a short time span. No tools, or at least simple hand tools, would further facilitate the erection process. Access to the shelter core interior would be a desirable feature throughout the articulation sequence. It would also be a distinct advantage to be able to accomplish articulation without interfering with fixed utilities or necessitating relocation of functional equipment stowed in the shelter core.

4. Utilization of the Interior - Shelter container interiors are to be utilized in a wide variety of manners including communication facilities, food preparation centers, maintenance functions,

personal sanitation, medical facilities, and other operations required by Army/85. Functional equipment associated with the above operations may be either an integral part of the shelter container or temporarily attached for stowage and set-up in operational form following the shelter erection.

Access location and type of access (whether single or double cargo doors, personnel doors, or a combination of cargo and personnel doors) are considerations which depend on total shelter system interior utilization needs, expandable configuration, and on structural elements.

A universal equipment attachment system, which interfaces with both fixed utilities and temporarily stowed equipment, is a desirable feature to consider in MMSS design. Limitations arise not only from the kind of facilities incorporated in the shelter container, but also from the geometries of expansion. It is found in many instances that only certain surfaces and spaces may be utilized for fixed and stored facilities. Optimization in these areas is a factor for evaluation.

Location and attachment of mechanical service outlets and connections is a consideration which is dependent upon equipment location and uninterrupted surfaces.

5. Joint Details - Joint design used in the MMSS must reliably perform a variety of functions. Fixed joints must be airtight, watertight, and, in most cases, must contribute structurally to the overall configuration. Elimination of through-metal is a priority. Movable joints must also accomplish these ends and additionally allow shelter expansion to take place. This requirement complicates matters since, in many cases, joints would serve more than one function and would often be required to lock in two positions. The addition of rollers, bearings, tracks, etc., would be required to facilitate shelter expansion in many configurations.

It should be noted that simple component interface, minimal joinery, and minimal accessories would be objectives leading to reliability, low cost and functional ease.

6. Transport Interface - In attempting to analyze the accumulated information on transport interface, several important factors were considered:

- a. the ability to transport shelter containers by as many vehicles as possible
- b. standardization of interface attachment devices
- c. interaction of transport interface and all other design parameters and criteria
- d. interaction of transport function with all other functions of the shelter container.

A list of transport vehicles and systems was compiled consisting principally of the contract parameters for helicopter sling, tactical ground vehicles, ground mobilizers, cargo aircraft and transport ships outfitted with ISO tiedowns. Also included were other ground mobilizers (forklift, straddle lift, and tactical ground vehicles) and the various interface devices.

Transport functions assessed included

- a. lifting from top or bottom (sling loads, forklift, straddle lift)
- b. touring (ground mobilizers, tactical ground vehicles)
- c. auxiliary mobilizing systems (conveyors, skids, air cargo loaders)
- d. long-range moving (air cargo, ship transport)
- e. securing (tiedown devices, pallet systems, other attachment devices).

As stated in the contract, it has also been necessary to consider ISO requirements, dimensional requirements, test loads, and general container structure.

Recommendations for transport interface revolve mainly around the ISO corner fitting and its particular ability to utilize a variety of attachment hardware. This includes hook, clevis, standard twist locks, and modified twist locks (Figure 31). Twist locks (standard and modified) are able to provide tie down capability, attachment devices for lifting operations, and devices for securing accessory pallets to the shelter container. Hooks and clevis devices are nearly restricted to lifting operations. (Figure 32.)

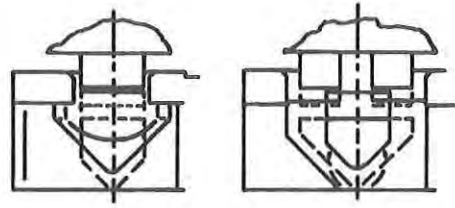

Standard Twist Locks

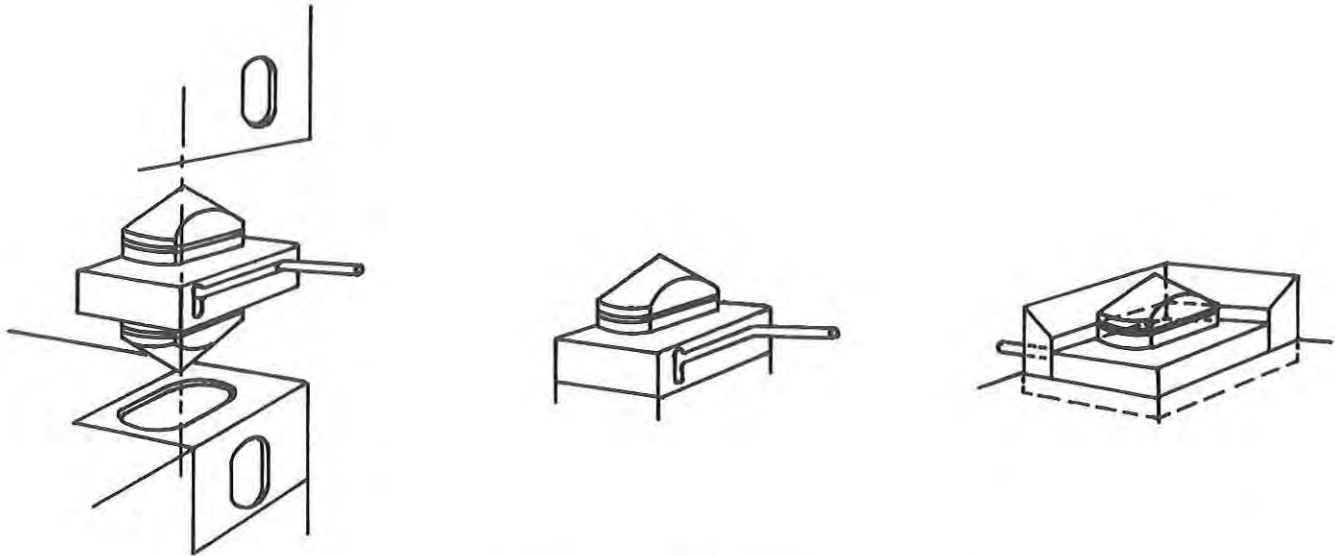

Twist Lock Types

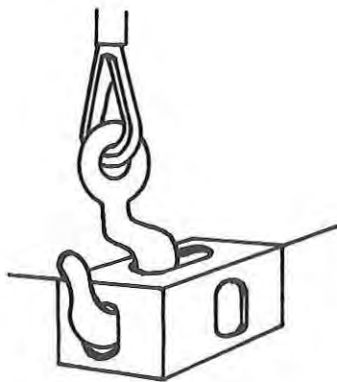

Hook

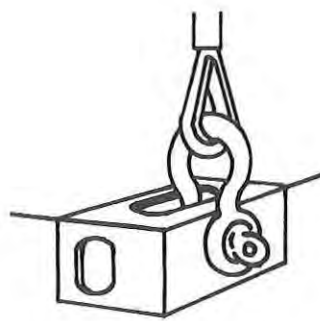

Clevis

Figure 31. ISO Corner Fitting Attachment Hardware

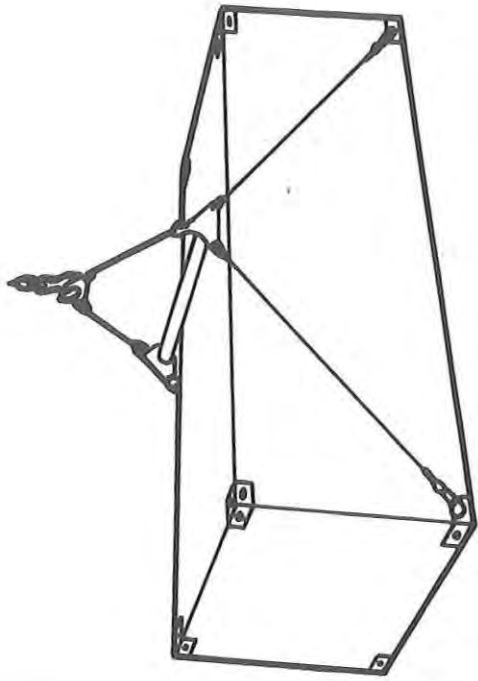
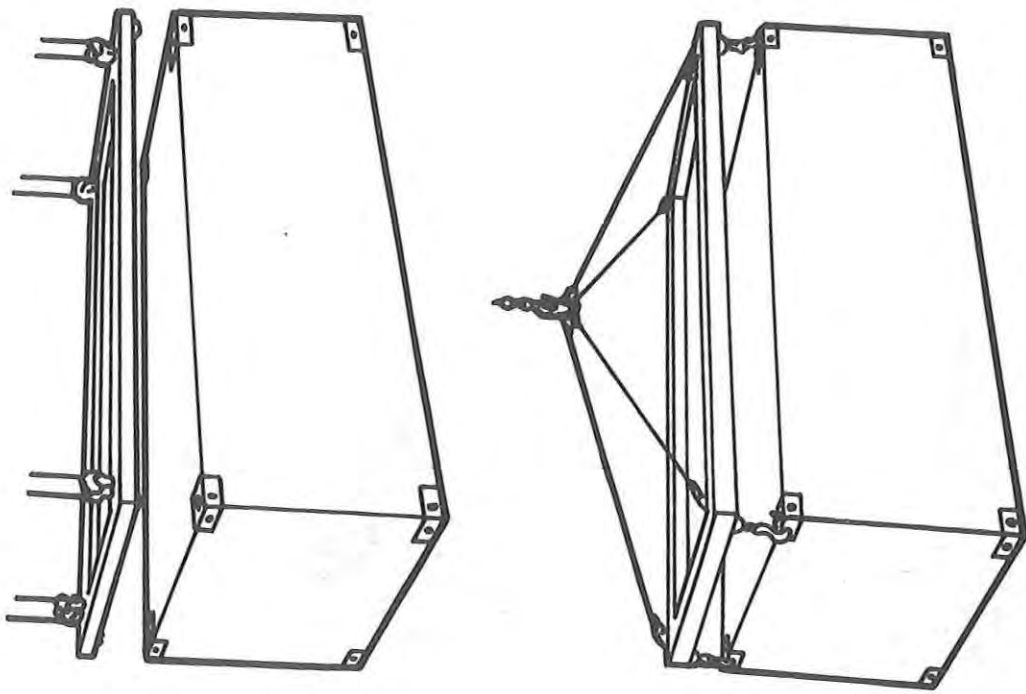

Figure 32. Sling Lifting Operations

Some touring operations can be done when the shelter container is assisted by some other base mobilizer (wheels, skids, etc.).

Figure 33 depicts a ground vehicle showing identical use as that of shelter container mobilizer.

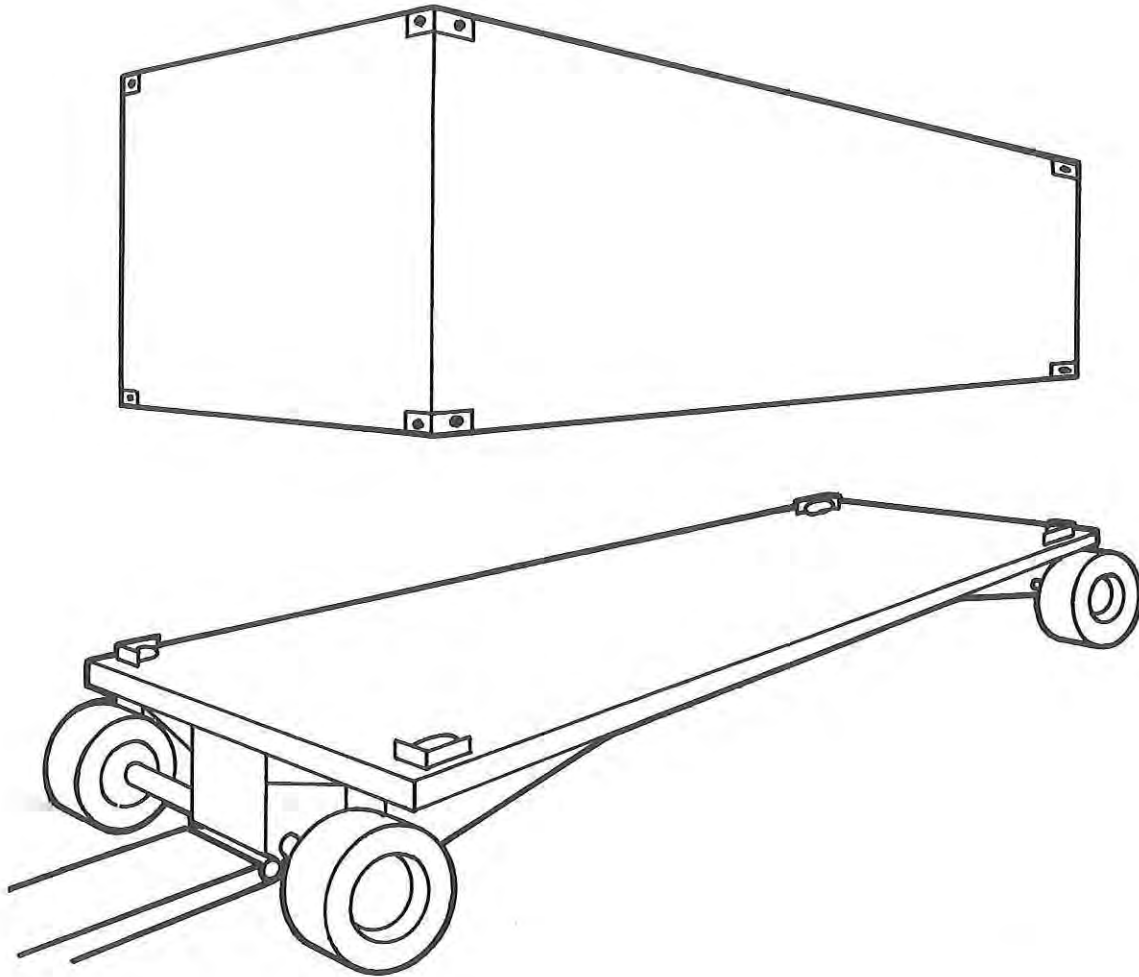

Figure 33. Ground Vehicle Carrying Operation

In Figure 34, a straddle lift demonstrates an alternate configuration for the bottom edge of the shelter container. As devices of the transport interface system, the ground vehicle provides uniform support on the bottom surface of the container, while the straddle lift arms can be

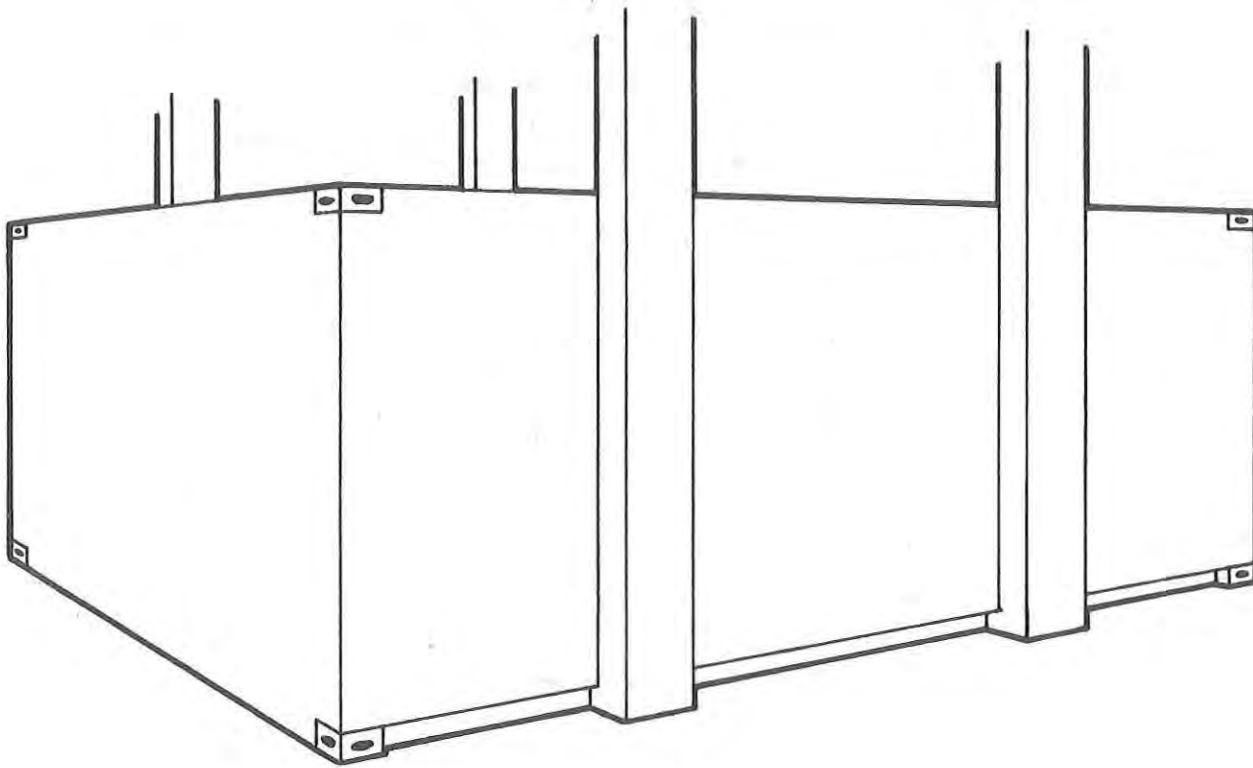

Figure 34. Straddle Lift

positioned to effectively lift long or unbalanced shelter containers. Helicopter sling (see Figure 32), ground mobilizer (Figure 35) and forklift (Figure 36.) must be evaluated carefully considering their inherent problems. Slings concentrate the load forces at the points of attachment, the corners. Also, slings have little control over unbalanced loads while care must be taken to prevent over stress of large heavy shelter containers. The ground mobilizer uses the shelter container as a partially stressed member; in effect it becomes the chassis of the vehicle and, as such, care must be taken to limit stressing of the shelter container. Forklifting of the container provides some problems. ISO recommends that containers 20 feet and larger be lifted in only unloaded configurations due to the near center lifting points. For example, tineways that are spaced 4 ft. apart (outer edges), centered, allowing, on a 20-foot container, 8 feet of nearly unsupported load to extend either

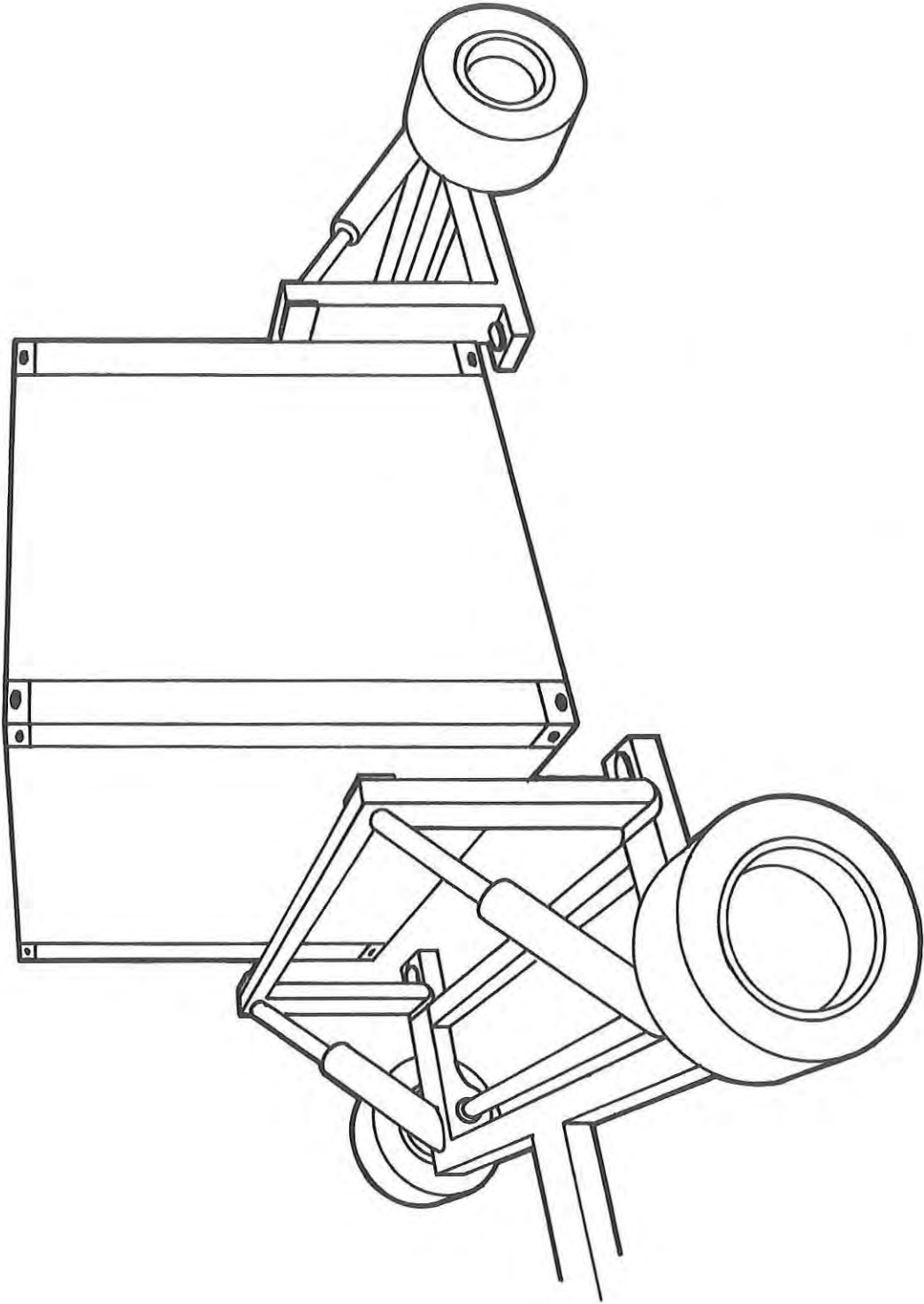

Figure 35. Ground Mobilizer Operation

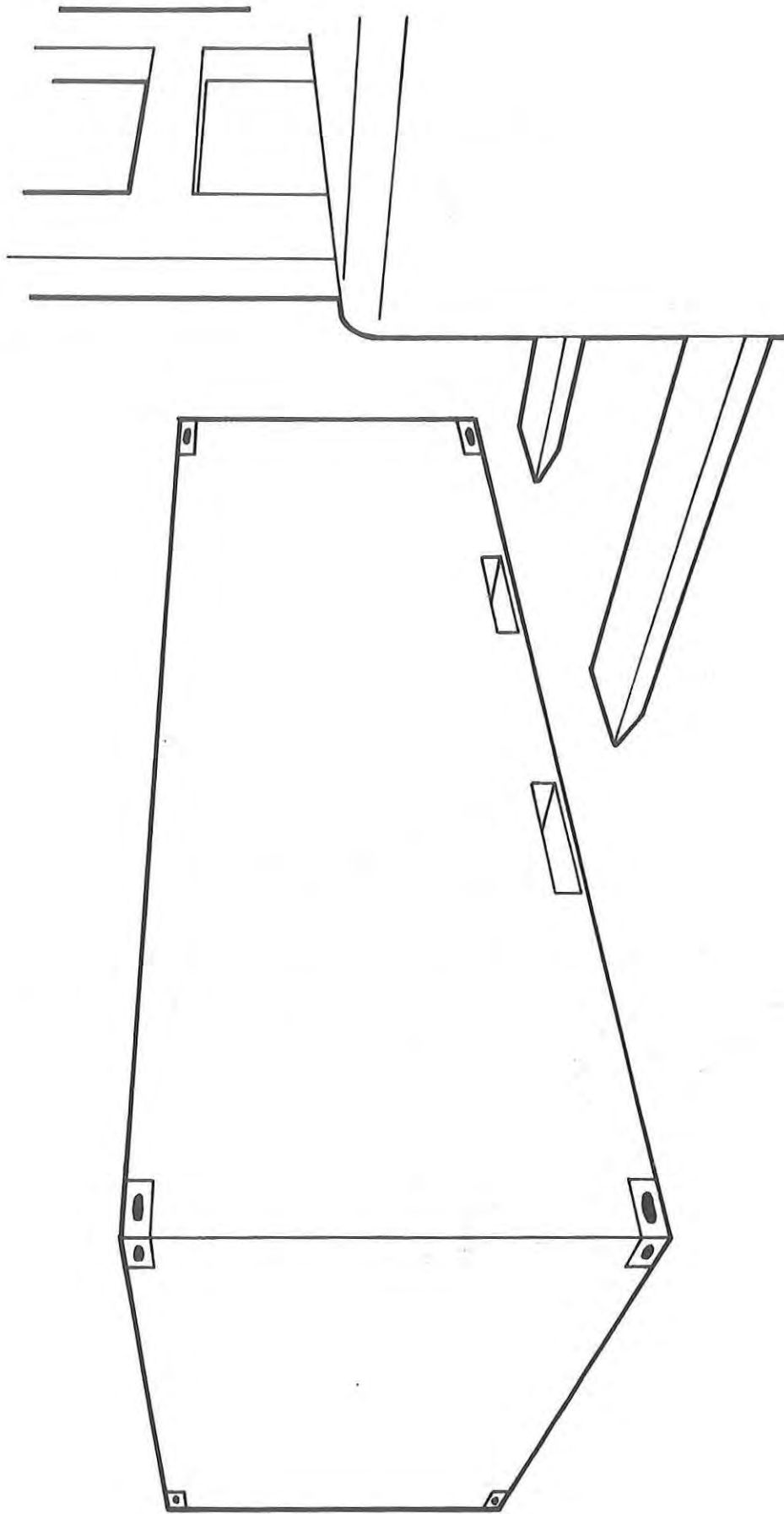

Figure 36. Forklift Operation

side of the container's center. Care must be taken to minimize stresses in transporting the shelter container by forklift.

The auxiliary pallet system provides many alternatives to transport problems or deficiencies. Shown in Figure 37 is one of the many air cargo 463L pallets.

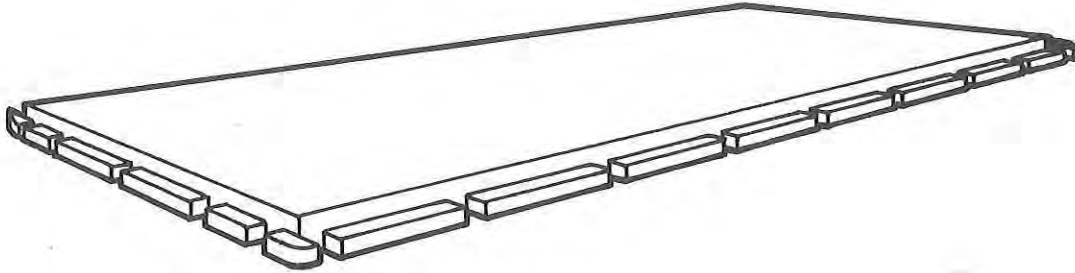

Figure 37. 463L Pallet

The auxiliary pallet system would allow use of particular pallet configurations designed to accommodate unique systems, like aircraft loading and securing. Pallets with integral skids (Figure 38 forklift and Figure 39 Straddle Lift) can be added

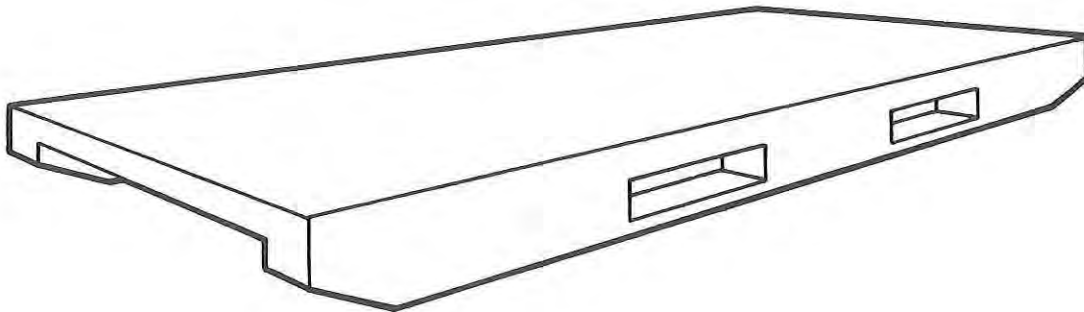

Figure 38. Forklift Pallet

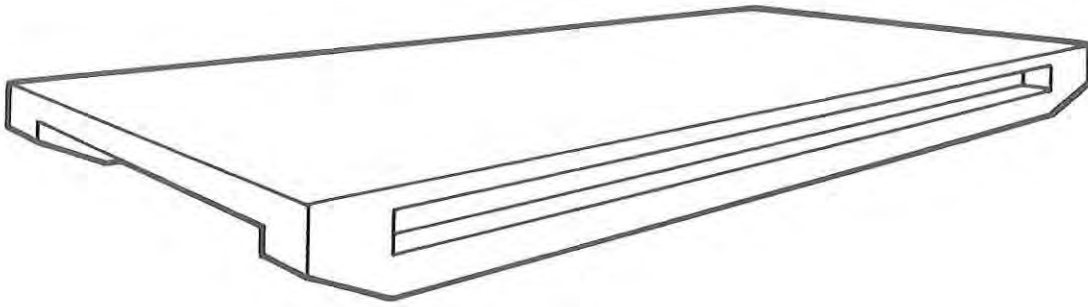

Figure 39. Straddle Lift Pallet

according to a particular situation need. A tunnel and gooseneck securing pallet is pictured in Figure 40, and a shock absorbing pallet is illustrated in Figure 41 to demonstrate the auxiliary pallet system's ability to provide solutions for many transport problems.

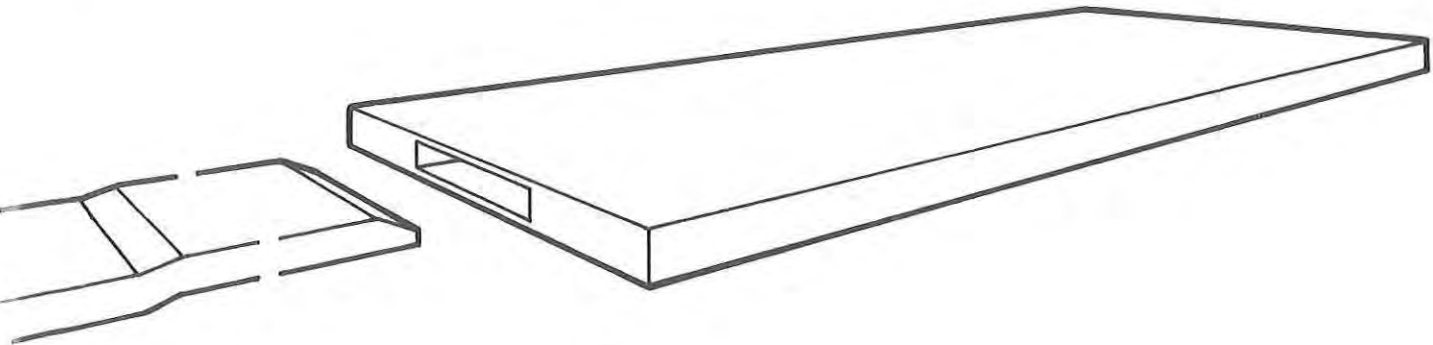

Figure 40. Tunnel Pallet

The ability to incorporate many forms of transport devices as standards on shelter containers remains to be seen. However, some systems because of configuration are incompatible. For example, all aircraft loading systems studied required flat bottom surface of the container for mobilization by roller devices; skids in nearly any configuration

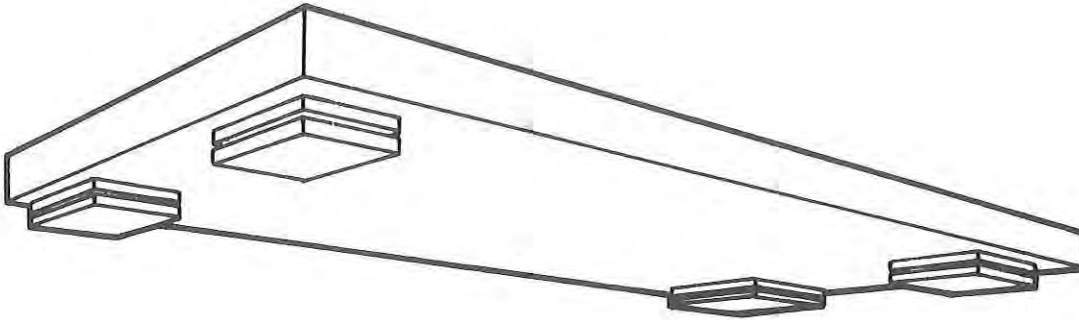

Figure 41. Shock Absorbing Pallet

would be incompatible. Consider stacking the containers six high for cargo ship transport. If the pallet accessories raise each container height 8", the use of any accessory pallets may be incompatible. It is nearly impossible at this time, because of a great variety of unique transport systems and devices, to assess or propose a combination of systems for ultimate transport capability. To do so would require considerable R & D work and standardization of attachment devices, standardized compatible air cargo loading and securing, standard slings, standard lifting devices, and ground mobilizers.

Projected trends incorporate more and more ISO type standardization and thus concepts generated will incorporate ISO transport standards. Concepts will also deal, to a greater extent, with transport interface and its relationship with shelter ground interface, shelter container access, shelter container frame construction and other design details related to transport.

7. Ground Interface - Methods of interfacing shelters with site surface must accomplish the following functions:
  - a. adequately support shelter floors in operational mode,
  - b. provide leveling facility on rough and/or inclined terrain,
  - c. provide necessary mechanical devices to facilitate expansion of expandable configurations,
  - d. if necessary, provide tie-downs to resist extreme wind loads, and

- e. when required, provide grounding for EMI shielding.

Additional desirable features include:

- a. a universal jacking device,
- b. components permanently attached to shelter to avoid loss, and
- c. ease of operation in extreme environmental conditions.

A detailed analysis of ground interface was not undertaken in this study. Consideration has been given to leveling systems as a necessary part of total shelter evaluation. This was based on the above criteria and the particular characteristics of the various design configurations which would tend to either complicate or simplify leveling system design. No specific designs were evolved, however, leaving this task to be performed at a subsequent, more detailed level of involvement.

8. EMI Shielding - Provision for EMI Shielding is a requirement of the MMSS which may be accomplished with varying degrees of effectiveness according to the method or methods which are possible within each of the five manufacturing processes. Since neither the amount of EMI attenuation expected, nor the percentage of total shelters requiring EMI shielding are determined, the following discussion is limited to consideration of feasible methods of EMI shielding and some basic EMI shielding design criteria.

The simplest and most effective method of insulating against EMI radiation is a grounded ferrous metal enclosure, welded continuously at all seams. Although highly effective against EMI radiation, this method would make a poor transportable shelter due to the lack of access, ineffective shelter thermal properties, high maintenance, and definite weight penalties.

The most effective, feasible method of incorporating EMI shielding into shelters is the use of steel or aluminum skinned-sandwich panels together with proper joint and door design.

Though less effective than metal skins, metallic foil may be incorporated in some designs; namely

the filament-wound configurations, to provide a degree of EMI shielding.

Another alternative is that of metal-plating injection-molded and thermoformed plastic shelter components.

A fourth method, the least effective, is the inclusion of metal screens in the plastic composites. This technique could be applied to FRP sandwich panels, filament-wound composites, and inherently the plastic-encapsulated metal screen in the rotomolded concepts.

Assuming a material has been selected which gives adequate shielding performance, the next critical factor is joint design. EMI leakage will occur whenever material integrity is interrupted, thus joint length should be minimal, have good surface-to-surface contact, and be tightly secured to prevent movement. Limiting joints to one plane interface and locating them away from stress lines improves long-run performance of EMI shielding.

In view of the demands imposed by the above criteria, non-expandable shelter containers are obviously better suited to applications requiring EMI shielding than the expandable shelters.

#### Requirements Review Conclusion

Consideration and preliminary evaluation of the factors mentioned in this section serve as guidelines to further levels of design and development to be undertaken in Functional and Component Design Levels.

#### B. Configuration Alternatives

A number of expandable configurations have been generated during this study. Of these, most may be produced by more than one manufacturing process and in any one of the various materials characteristics of that process. In all, hundreds of distinct designs might be adapted to the six shelter containers visualized in the MMSS design concept. The following chart serves to categorize the design configurations (A thru Q) according to manufacturing process (Table XXIII).

Material alternatives were discussed in the Materials and Processes Section, beginning on page 11.

TABLE XXIII.

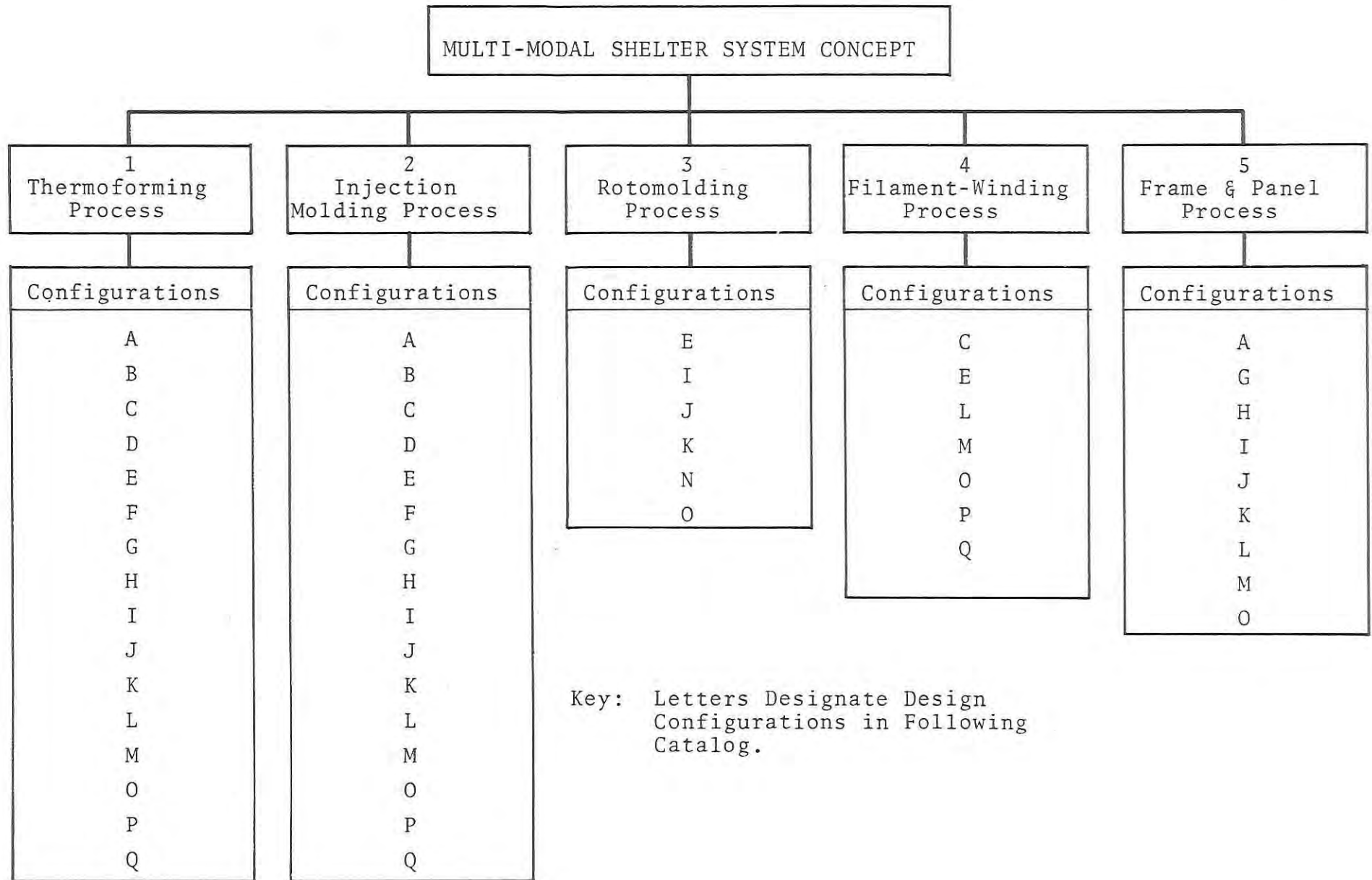

## C. Design Configuration Catalog

The following is a catalog of the expandable configurations A-Q. A brief description of standardized construction, erection procedure, interior utilization, and joinery supplemented with an exploded view of major components, erection procedure, and joint sections are found for each item.

Configuration A - A basic panel system for both expandable and non-expandable configurations. Panels may be manufactured by conventional sandwich panel processes as by injection-molding or thermoforming various plastic materials. (Figure 42.)

### 1. Components

- 3 frame sizes, using common parts
- 3 floor lengths
- 3 side wall, roof panel lengths
- 3 pallet lengths
- 1 common core endwall
- 1 common cargo-personnel door
- 1 common folding endwall
- 1 universal leveling device

16 Major Basic Components

### 2. Expansion Procedure (Figure 43, Figure 44.)

- a. Shelter core is leveled on jack standards
- b. Sidewalls are unlocked, dropped into expanded position, (becoming shelter floor) and leveled on jack standards
- c. shelter sidewalls are raised
- d. roof panel is swung up and into position
- e. endwalls hinge into position
- f. locking devices secure panels.

### 3. Utilization of Interior

Access:

- Container - split cargo door in one end.
- Shelter - split cargo door in one end, additional personnel doors may be incorporated in wall panels, endwalls themselves open for greater access.

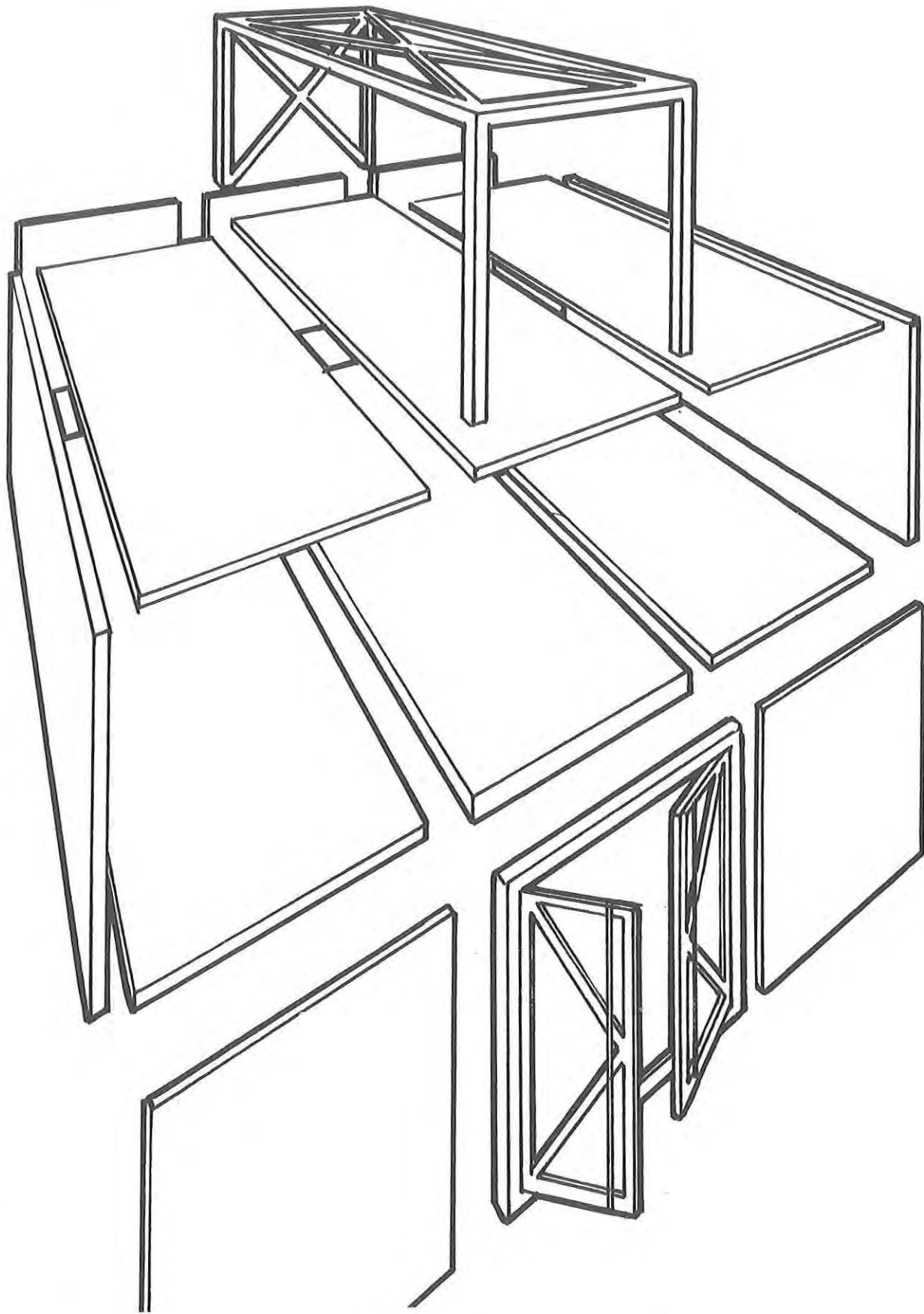

Figure 42. Configuration A

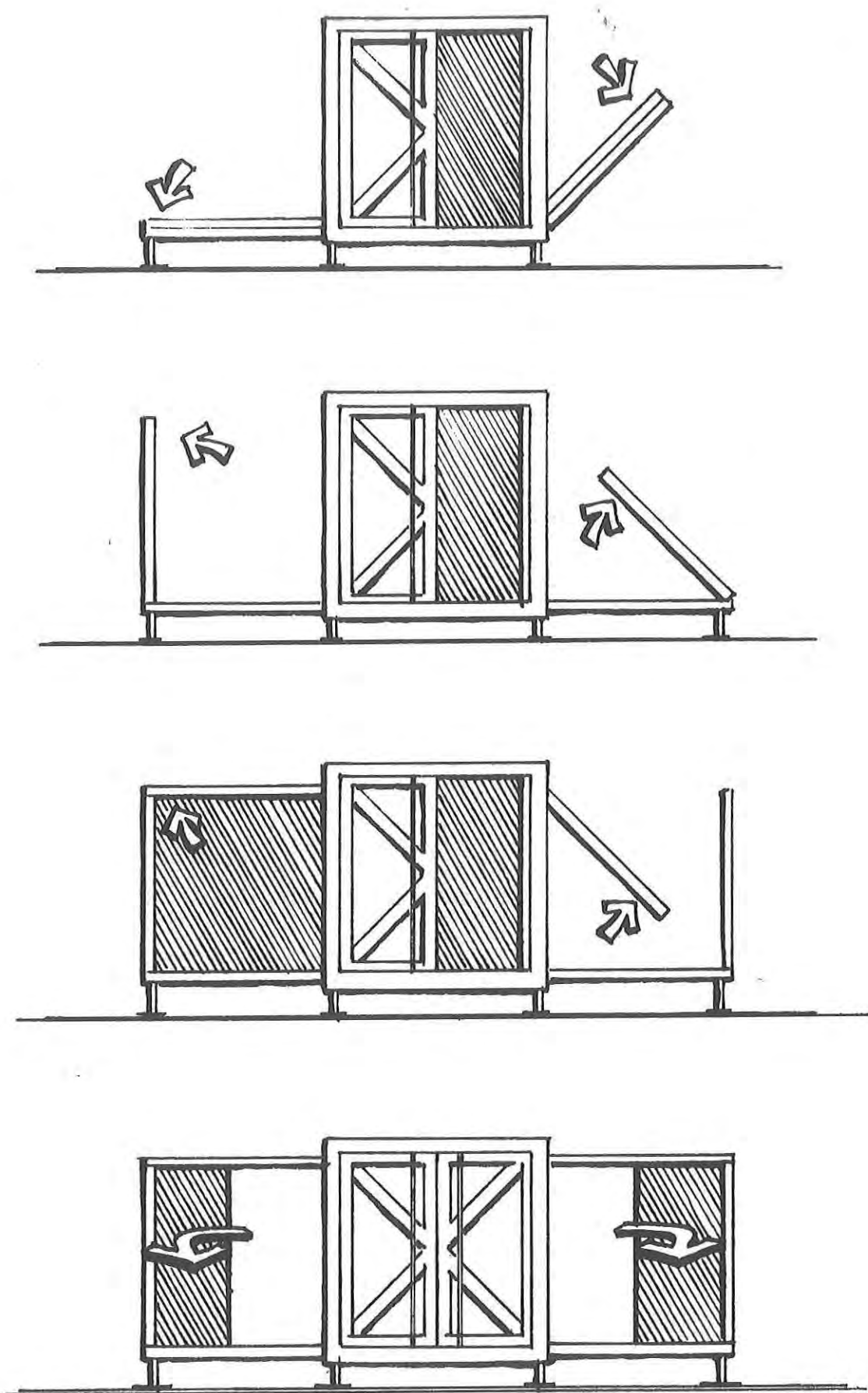

Figure 43. Expansion Procedure

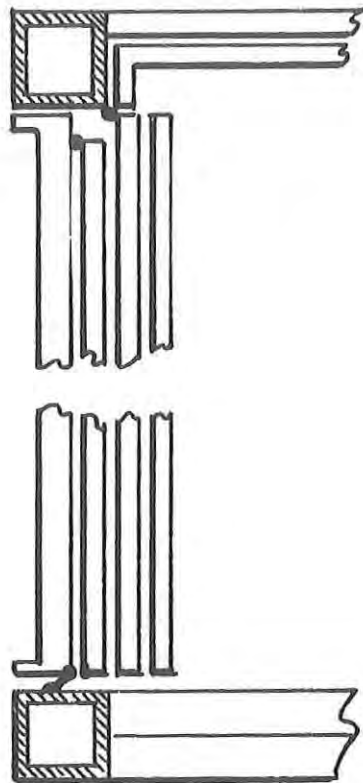

Figure 44. Longitudinal Section, Container Mode

Attachments:

- |                 |   |   |
|-----------------|---|---|
| Container-fixed | - | floor, end, sides, roof   |
| temporary       | - | floor, end, sides, roof   |
| Shelter -fixed  | - | floor, end, roof  |
| temporary       | - | floor, end, roof, possibly<br>some surfaces of expandable<br>panels.                        |
| Mechanical      | - | shelter core endwall provides<br>best location for standard<br>mechanical attachment point. |

4. Joinery

Airtight, relatively watertight shelter is quite feasible. Locking devices, articulating hinges, and weather stripping are critical factors.

Configuration B - Injection-molded or thermoformed plastic components form two-sided telescoping expandable configurations. Common core components plus side walls form non-expandable configurations. (Figure 45.)

1. Components

System I

3	Frame sizes, using common parts
6	Floor sizes
3	Pallet sizes
3	Non-expandable cores
3	Expandable cores
6	Expandable modules
1	Folding endwall
1	Common cargo-personnel door
1	Universal leveling device
1	Common expansion track
<hr/>	
28	Major Basic Components

System II

3	Frame sizes, using common parts
6	Floor sizes
3	Pallet sizes
3	Cores
3	Expandable modules
3	Sidewalls
1	Common cargo-personnel door
1	Universal leveling device
1	Common expansion track
<hr/>	
24	Major Basic Components

2. Expansion Procedure (Figures 46, 47.)

- a. Shelter core is leveled on jack standards
- b. Expansion tracks and outer jack standards are located in position and leveled
- c. Expandable modules are rolled out on tracks - floors simultaneously drop into place
- d. Endwalls hinge into position from storage location
- e. locking devices secure panels

3. Utilization of Interior

Access:

Container - split cargo door in one end

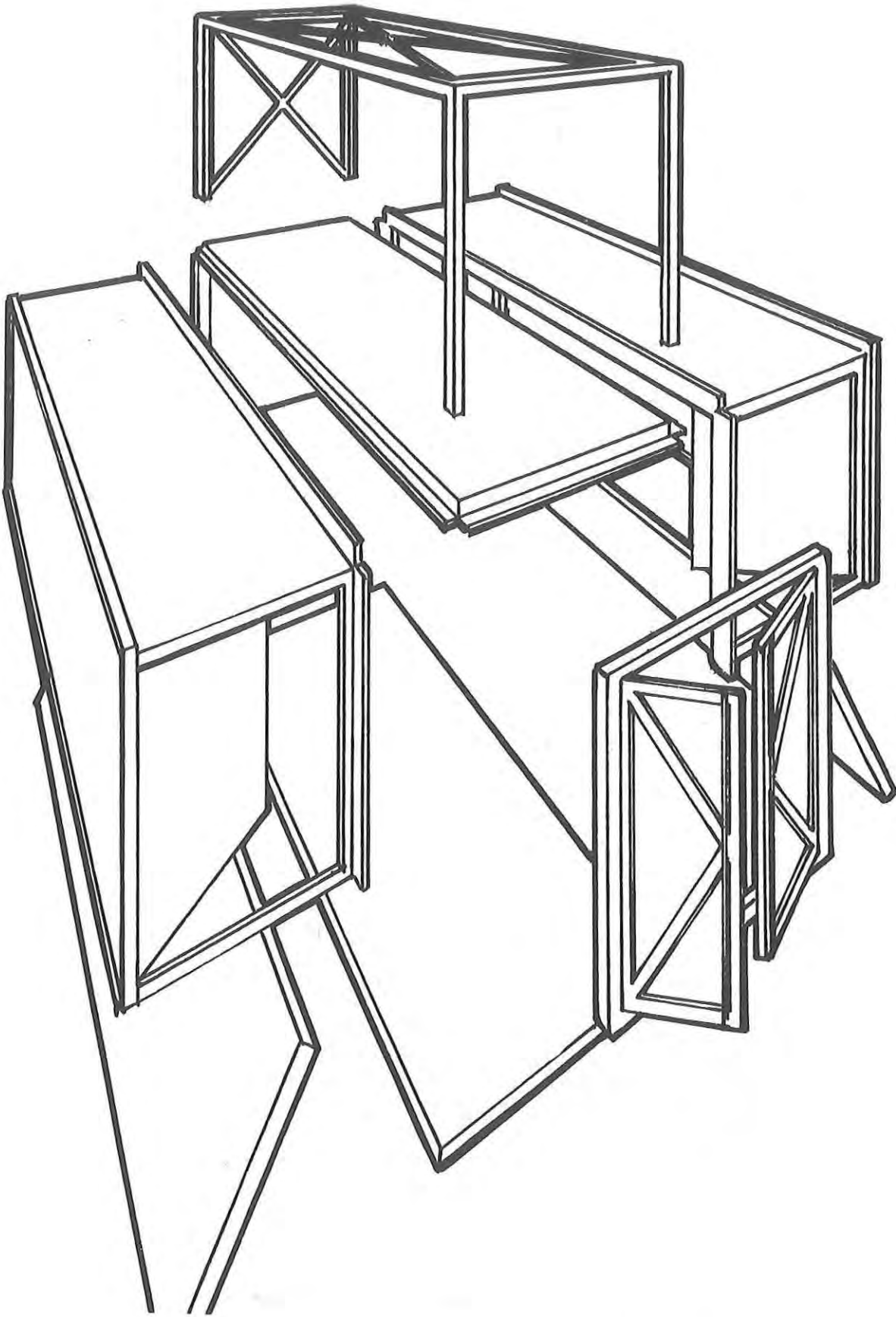

Figure 45. Configuration B

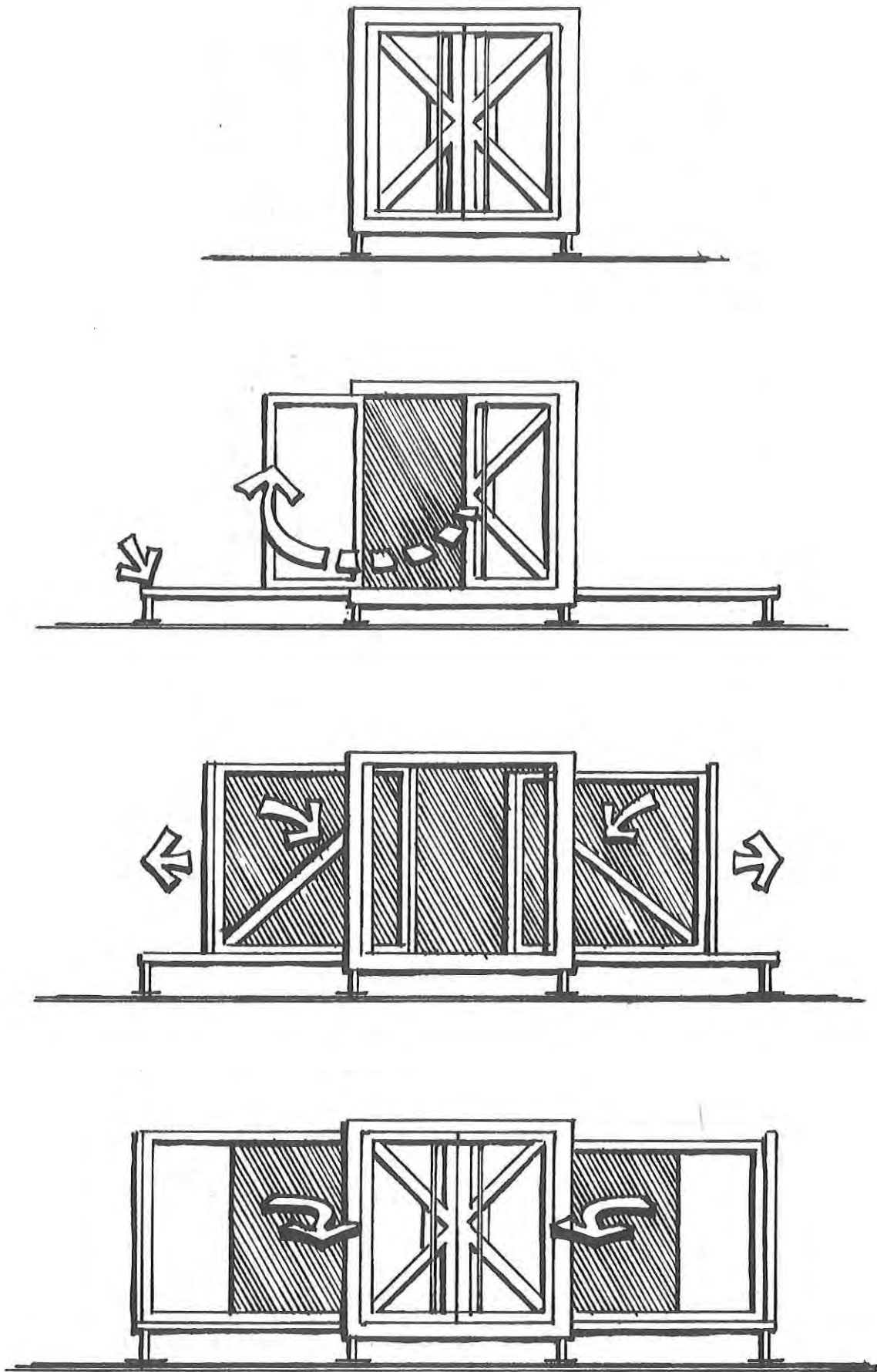

Figure 46. Expansion Procedure

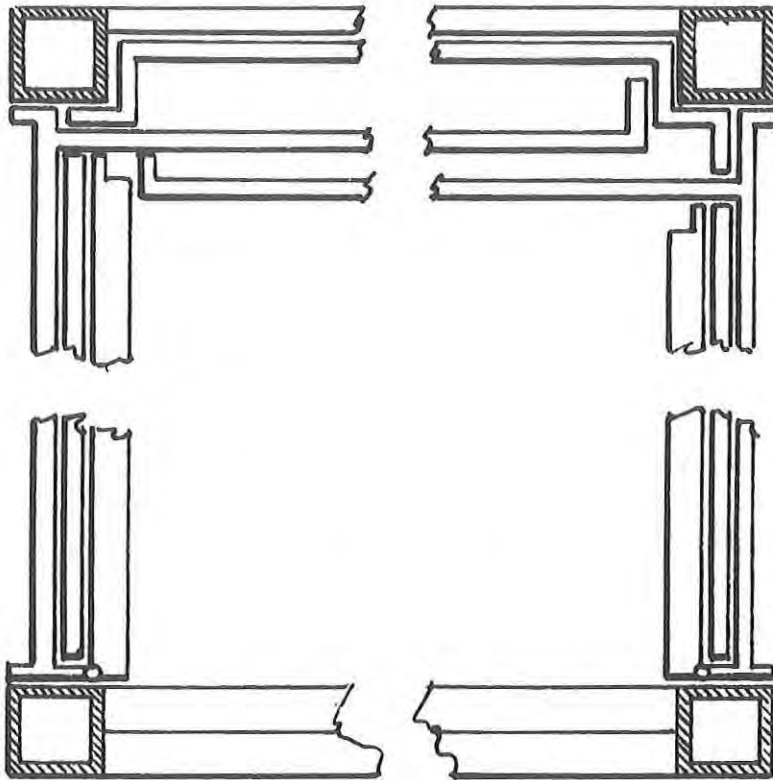

Figure 47. Longitudinal Section, Container Mode

Shelter - split cargo door in one end,  
folding endwalls may open for  
additional access.

Attachments:

- |                   |   |   |
|-------------------|---|---|
| Container - fixed | - | floor, end, sides, roof   |
| temporary         | - | floor, end, sides roof  |
| Shelter - fixed   | - | core floor  |
| temporary         | - | core floor, bottoms of<br>expanding floor panels.   |
| Mechanical        | - | shelter core endwall pro-<br>vides possible location for<br>mechanical attachments -<br>usable only when erected. |

4. Joinery

Airtight, watertight shelter is possible. Great-  
est problems are bearings and mechanics required  
for expansion and seals between expandable modules  
and shelter core.

Configuration C - This two-sided telescoping configuration may be produced in plastic by injection molding or thermoforming large components and using an external frame or by filament winding a plastic composite with an integral frame, using injection molded or thermoformed expandable modules.

1. Components (Figure 48.)

Injection molded or Thermoformed

- 3 Frame sizes, using common parts
- 5 floor sizes (6-2/3'\*, 3-1/3', 10'\*, 13-1/3', 20'\*)  
\* double as non-expandable side walls
- 3 Pallet sizes
- 1 Core end module
- 2 Core roof modules
- 6 Expandable modules
- 1 Side access door
- 1 Universal leveling device
- 1 Common expansion track

---

23 Major Basic Components

Filament-wound (Figure 49.)

- 3 Core sizes (integral frame)
- 3 Pallet sizes
- 5 Floor sizes (6-2/3'\*, 3-1/3', 10'\*, 13-1/3', 20'\*)  
\* double as non-expandable side walls
- 6 Expandable modules
- 1 Side access door
- 1 Universal Leveling device
- 1 Common expansion track

---

20 Major Basic Components

2. Expansion Procedure (Figures 50, 51, 52.)

- a. Shelter core is leveled on jack standards
- b. Expansion tracks and leveling devices are located and leveled
- c. Expandable modules are rolled out on tracks
- d. Access side has folding floor which hinges twice into position, opposite side has single floor panel which hinges into position
- e. Locking devices secure components and seal edges.

3. Utilization of Interior

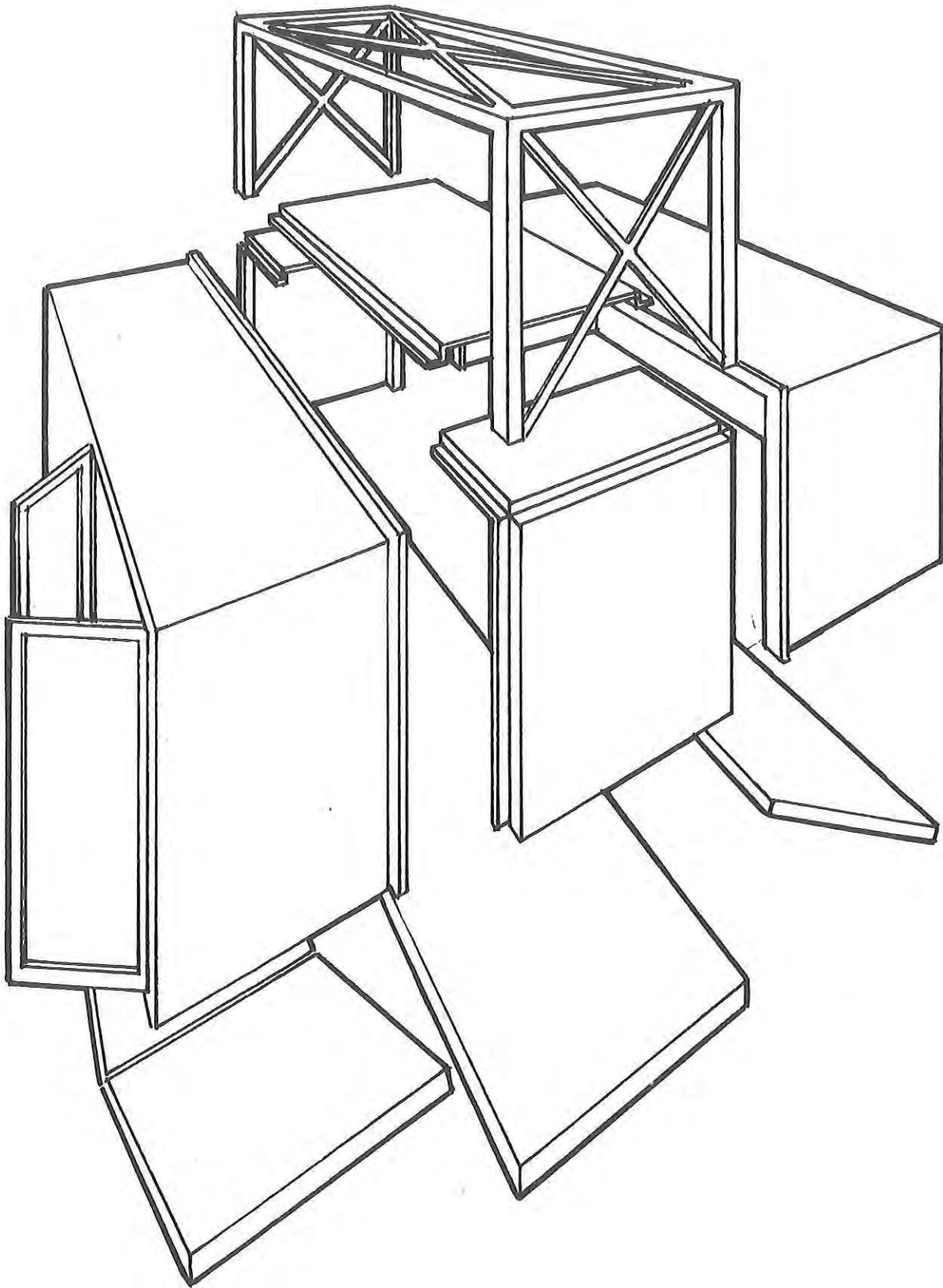

Figure 48. Configuration C  
Injection Molded or Thermoformed

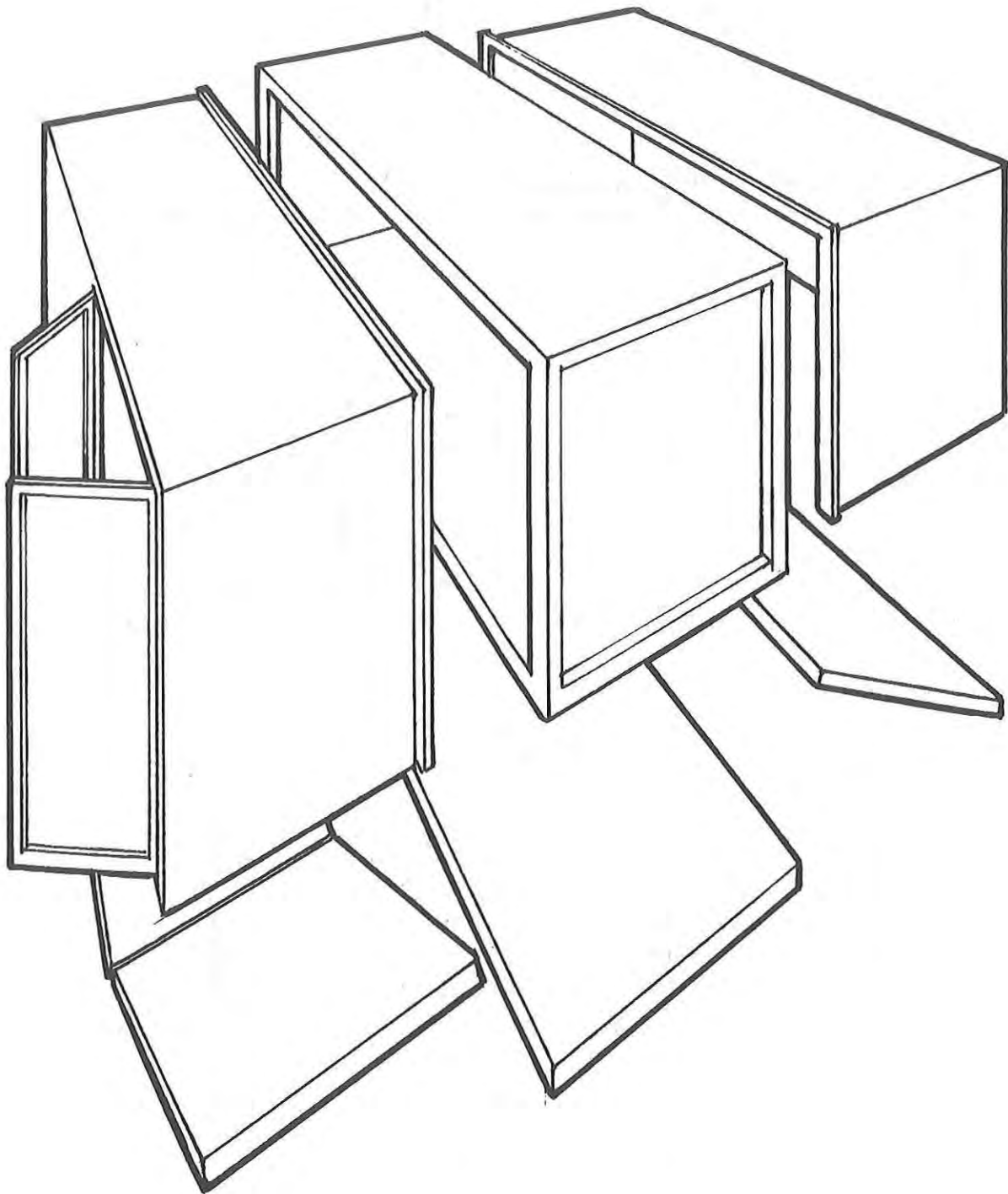

Figure 49. Configuration C  
Filament Wound

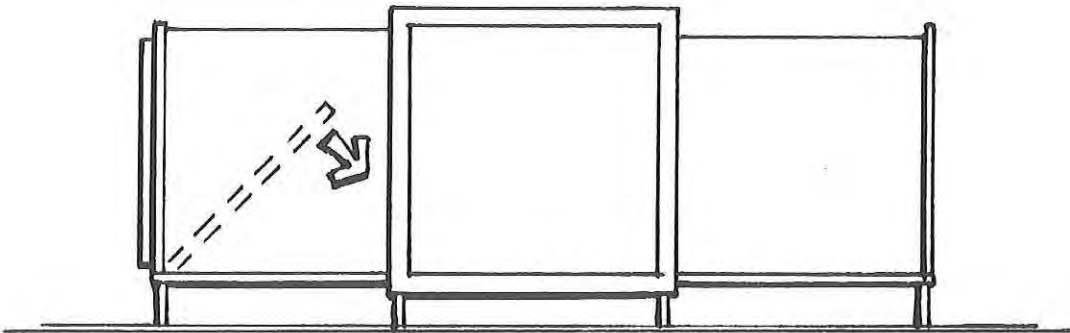
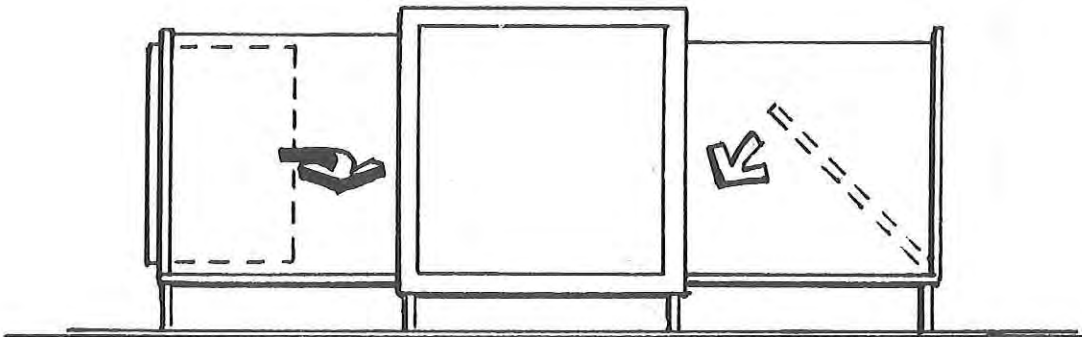
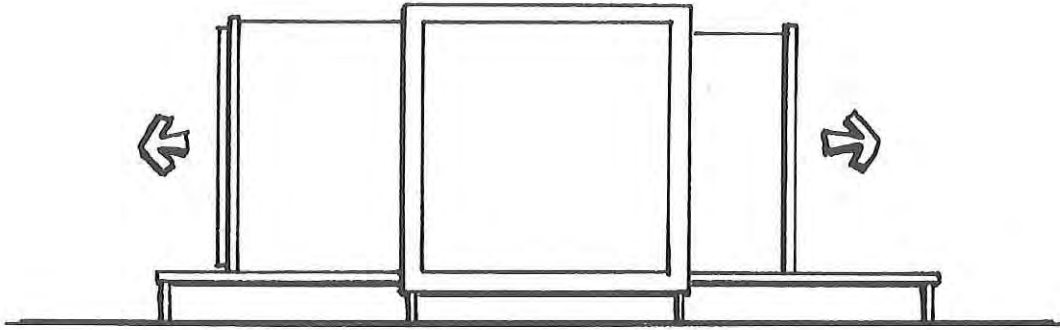
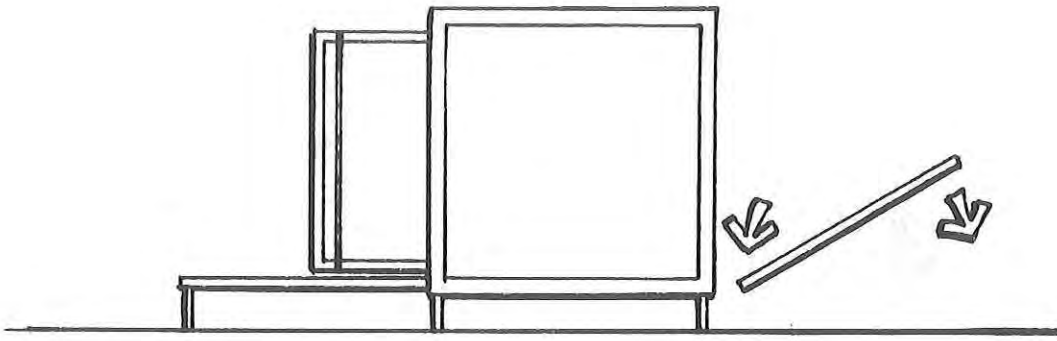

Figure 50. Expansion Procedure

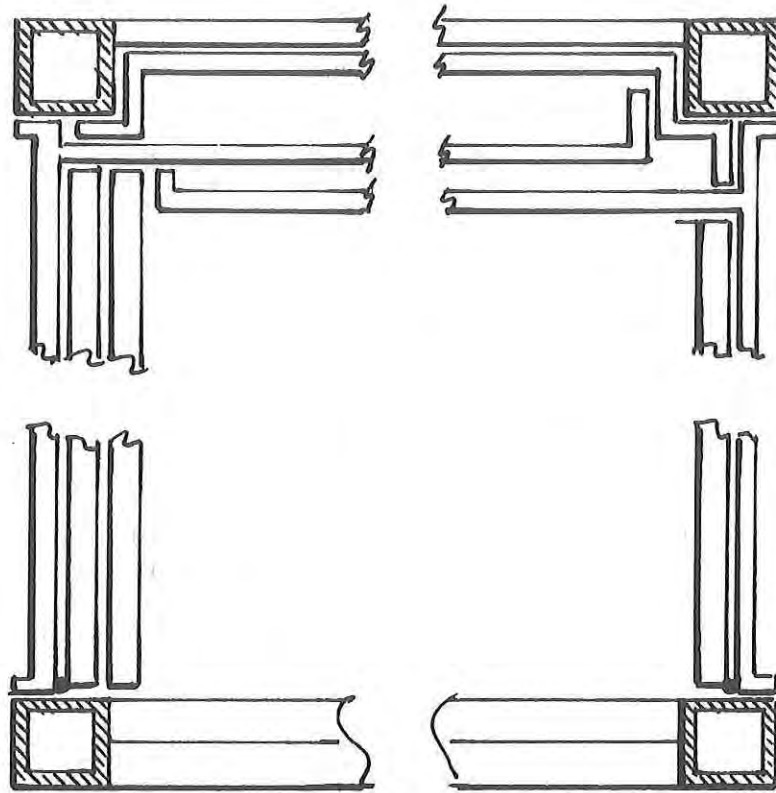

Figure 51. Longitudinal Section, Container Mode

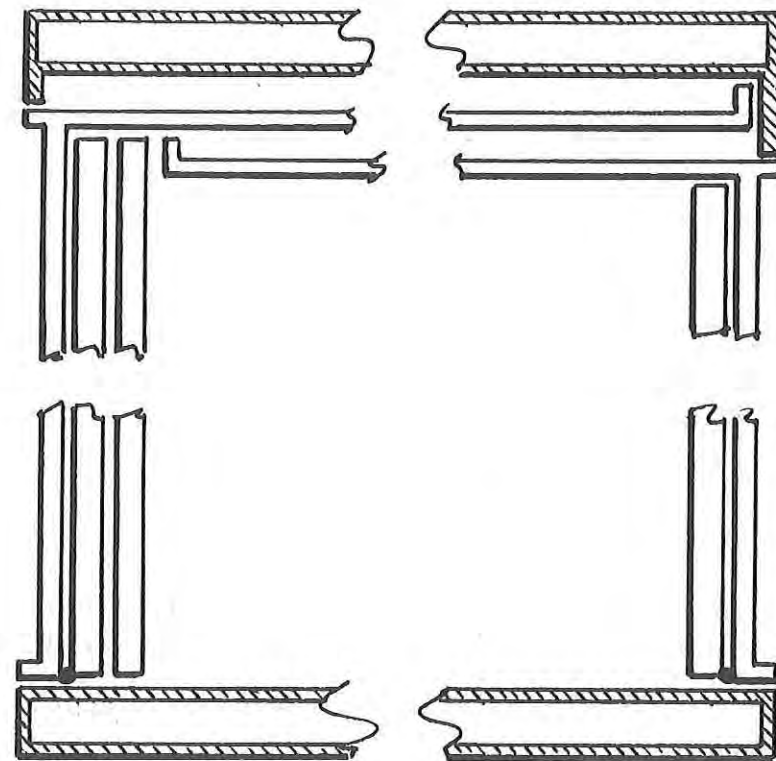

Figure 52. Longitudinal Section, Container Mode

## Access:

- Container - 6-2/3' double doors in side.
- Shelter - 6-2/3' double doors in side

## Attachments

- Container - fixed - floor, sides, end, roof
- temporary - floor, sides, end, roof
  
- Shelter - fixed - shelter core floor
- temporary - shelter core floor,  
                      expanding floor bottoms.
  
- Mechanical - access side wall provides  
                  best possible location  
                  for mechanical connections,  
                  usable only when erected.

## 4. Joinery

Airtight, watertight shelter is possible; greatest problem areas are bearings and mechanisms required for expansion, and seals between modules and shelter core.

Configuration D - This single-sided telescoping configuration may be produced in plastic by injection molding or thermoforming large components.

### 1. Components (Figure 53.)

- 6 Expandable modules
- 3 Frame sizes, using common parts
- 3 Pallet sizes
- 6 Expandable floor sizes
- 3 Expandable cores
- 3 Non-expandable cores
- 1 Common cargo-personnel door
- 1 Common leveling device
- 1 Folding endwall
- 2 Expansion Tracks

---

29 Major Basic Components

### 2. Expansion Procedure (Figures 54, 55.)

- a. Shelter core is leveled on jack standards
- b. Side expansion tracks and outer jack standards are located and leveled
- c. Expanding modules are rolled out on expansion tracks.

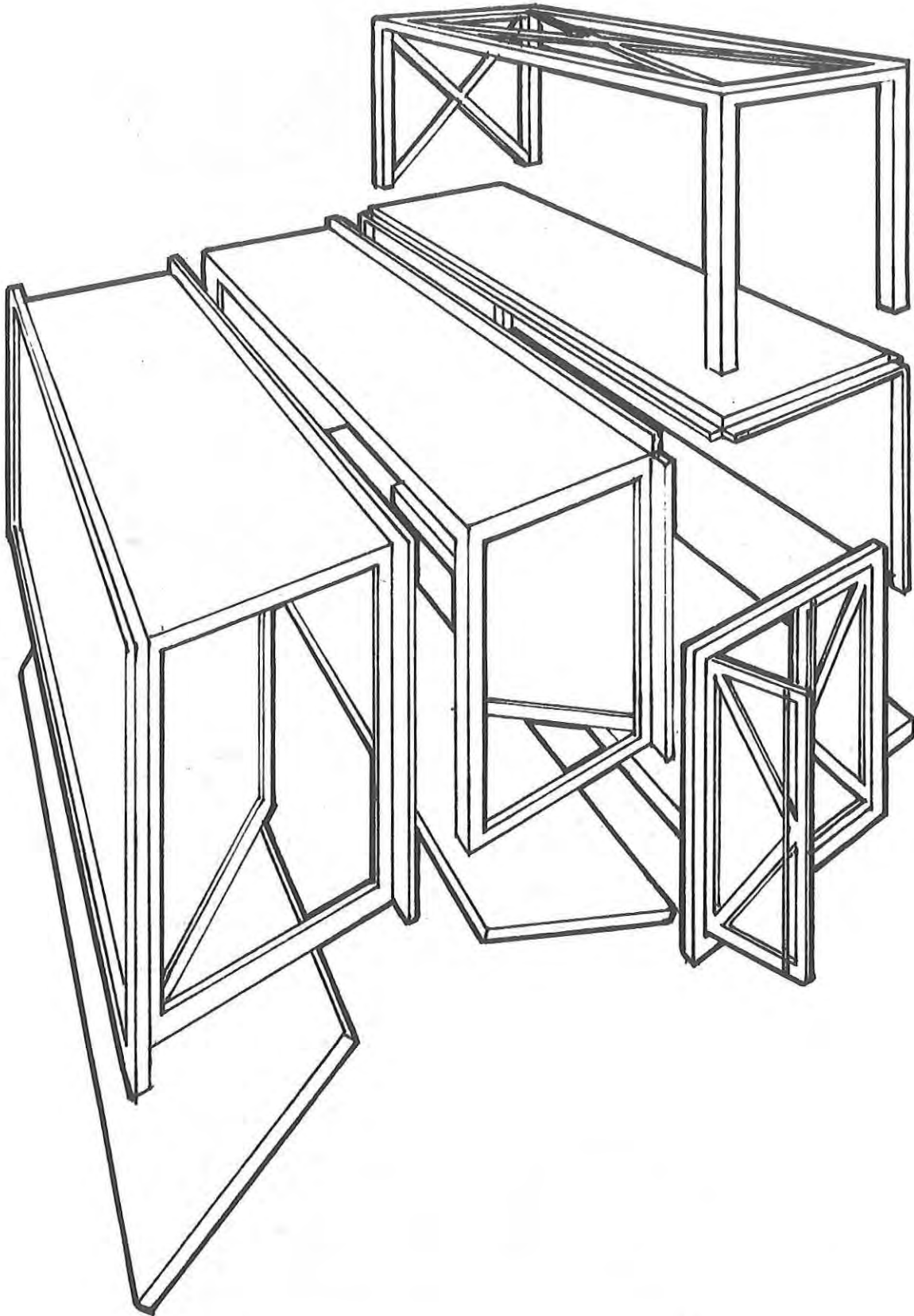

Figure 53. Configuration D

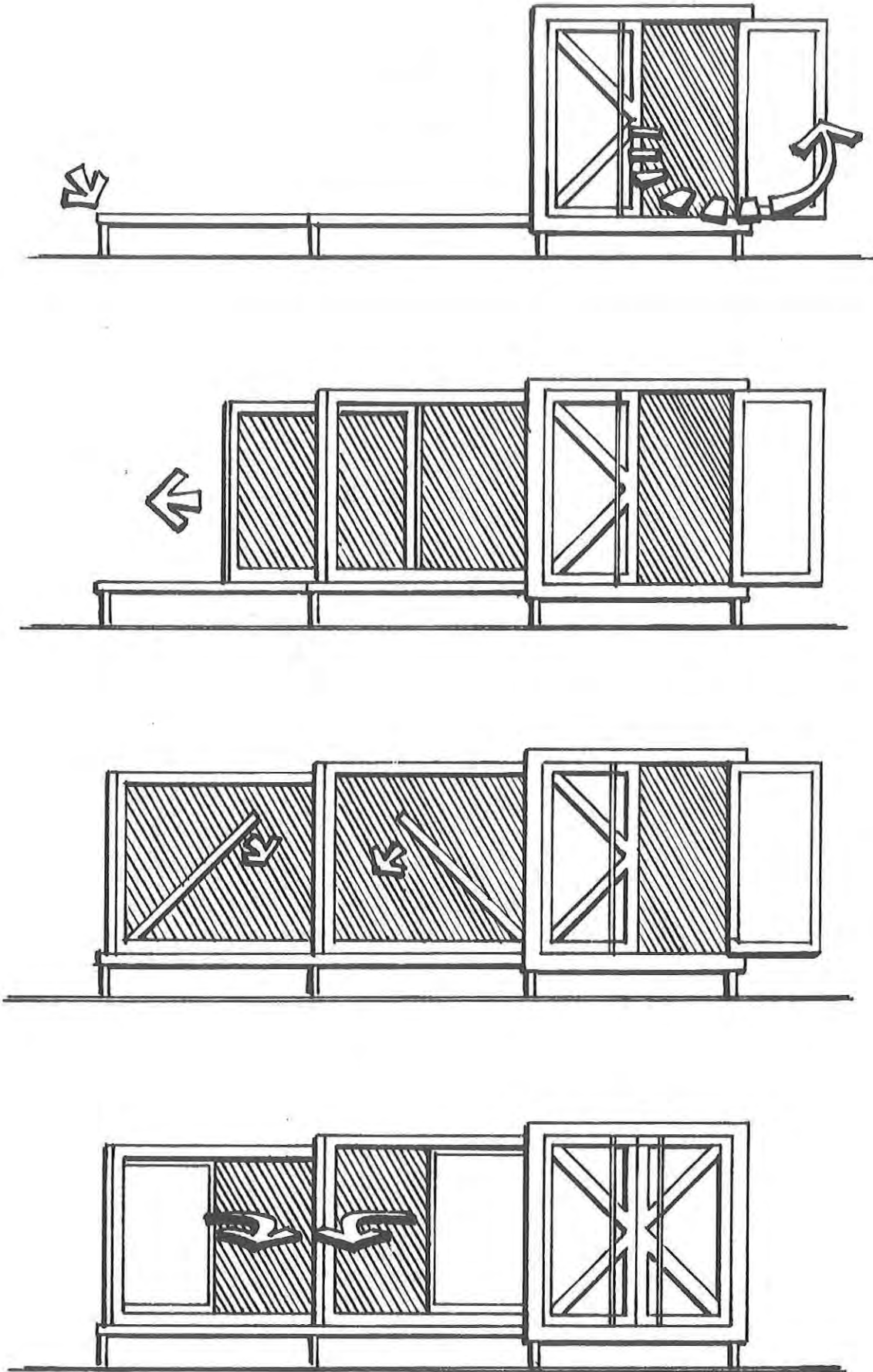

Figure 54. Expansion Procedure

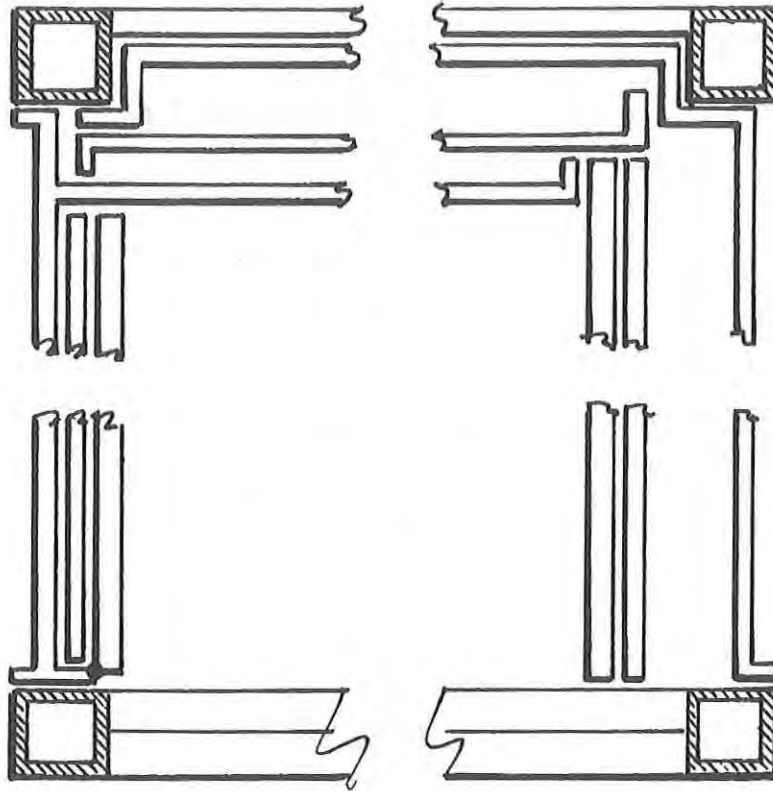

Figure 55. Longitudinal Section, Container Mode

- d. Floors swing into position
- e. End walls unfold into position
- f. Locking devices secure components

### 3. Utilization of Interior

#### Access:

- Container - split cargo/personnel door in container end
- Shelter - split cargo/personnel door in container end. Additional access possible through folding end walls.

#### Attachments

- Container - fixed - floor, sides, end, roof
- temporary - floor, sides, end roof
- Shelter - fixed - none
- temporary - floor, bottoms of expanding floors

- Mechanical                    - Shelter core end wall is best possible location, usable only when shelter is erected.

4. Joinery

Airtight, relatively watertight shelter is possible. Major problems are with expansion track and mechanisms, weathersealing between modules.

Configuration E - This single-sided telescoping configuration may be produced in plastic by injection-molding or thermoforming large components, using an external frame; or by filament-winding a shelter core with integral frame and using injection-molded or thermoformed expanding modules.

1. Components (Figure 56.)

Injection molded or Thermoformed

- 3 Frame sizes, using common parts
- 3 Pallet sizes
- 6 Expanding modules
- 6 Floor sizes
- 6 Side walls (3 with door openings)
- 1 Core end module
- 2 Core roof modules
- 1 Common access door
- 1 Universal leveling device
- 1 Common expansion track

---

30 Major Basic Components

Filament Wound

- 3 Cores with integral frame
- 3 Pallet sizes
- 6 Expanding modules
- 6 Floor sizes
- 6 Side wall sizes (3 with door openings)
- 1 Common access door
- 1 Universal leveling device
- 1 Common expansion track

---

27 Major Basic Components

2. Expansion Procedure (Figures 57, 58.)

- a. Shelter core is leveled on jack standards
- b. Side expansion tracks and outer jack standards are located and leveled

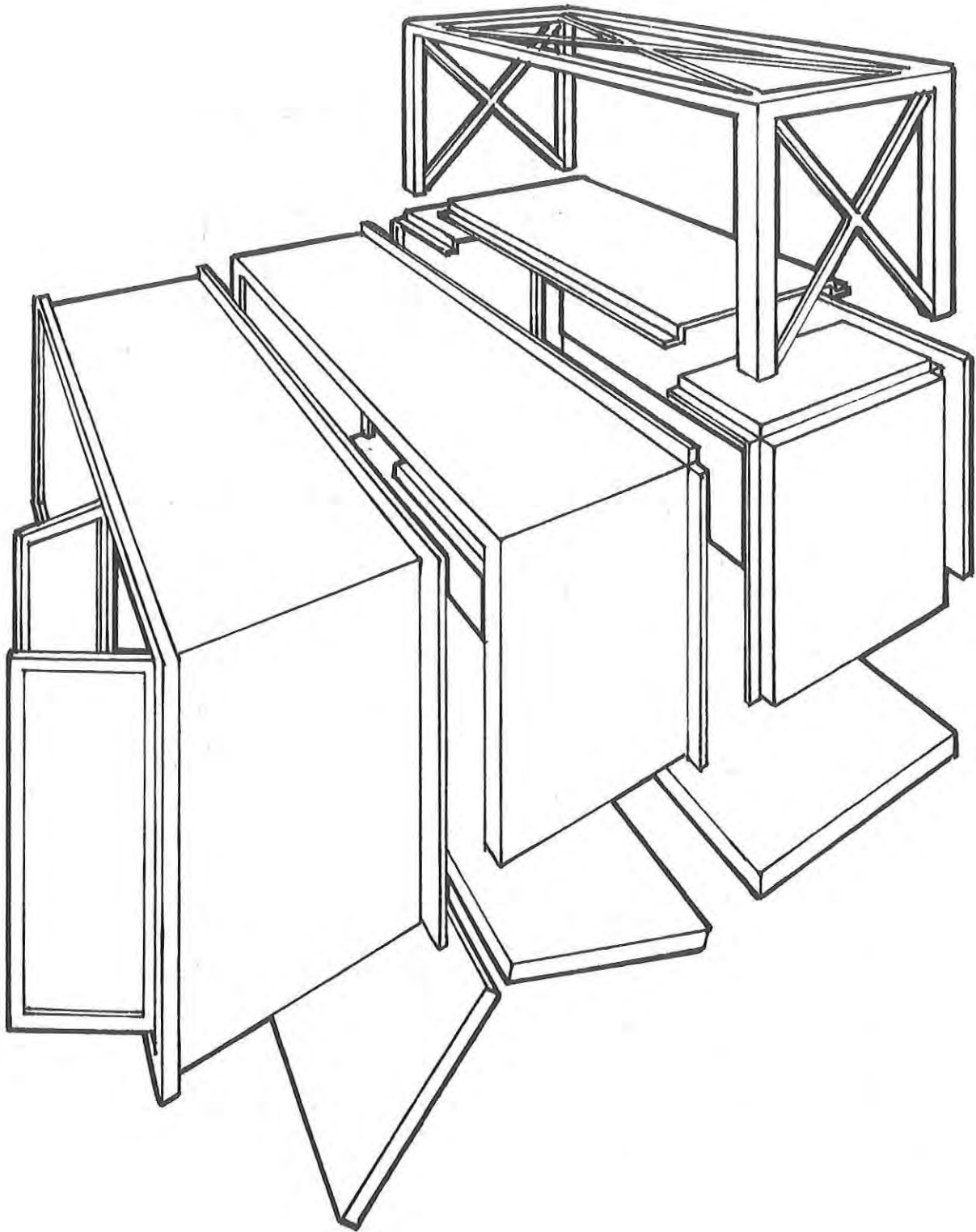

Figure 56. Configuration E

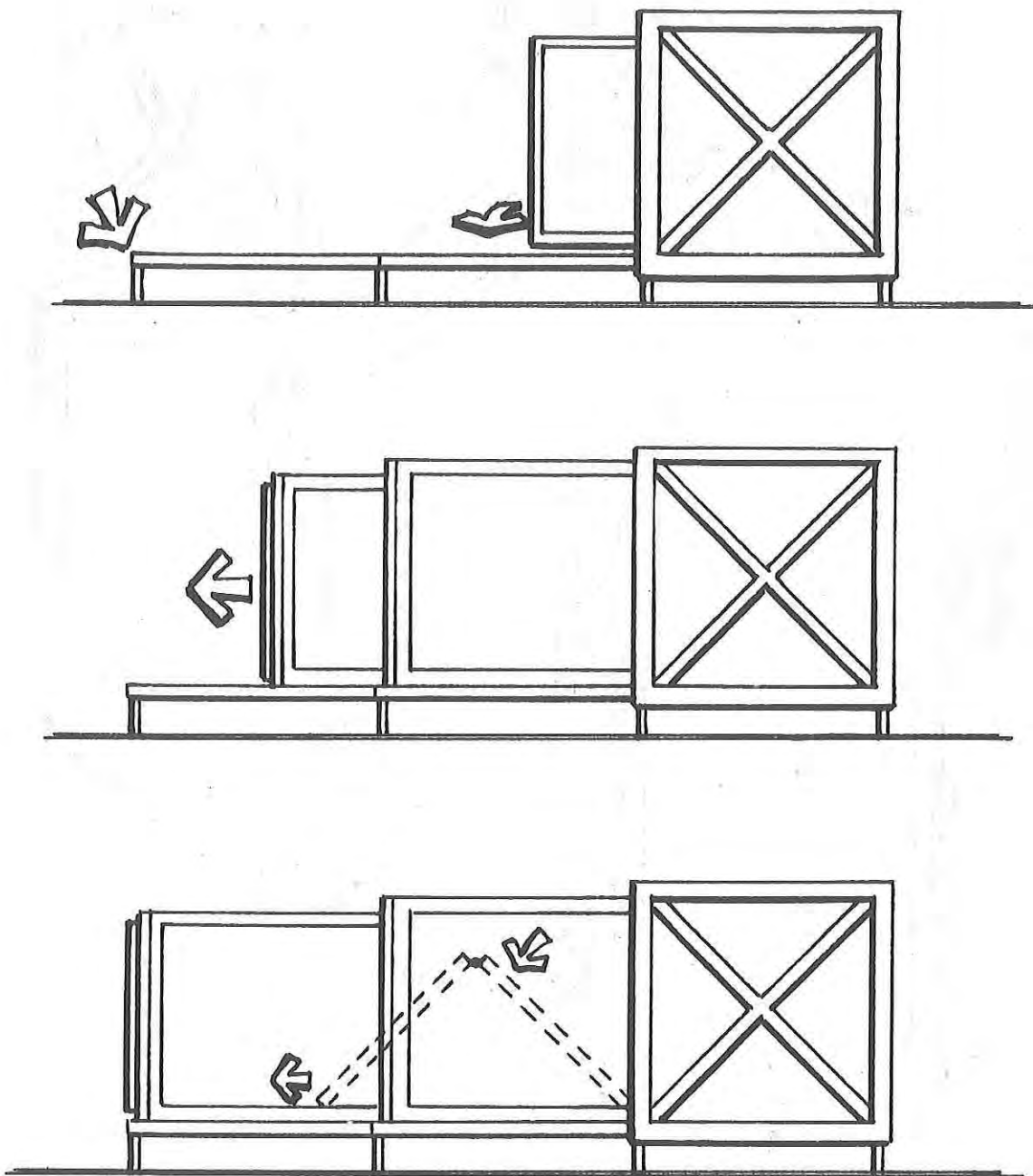

Figure 57. Expansion Procedure

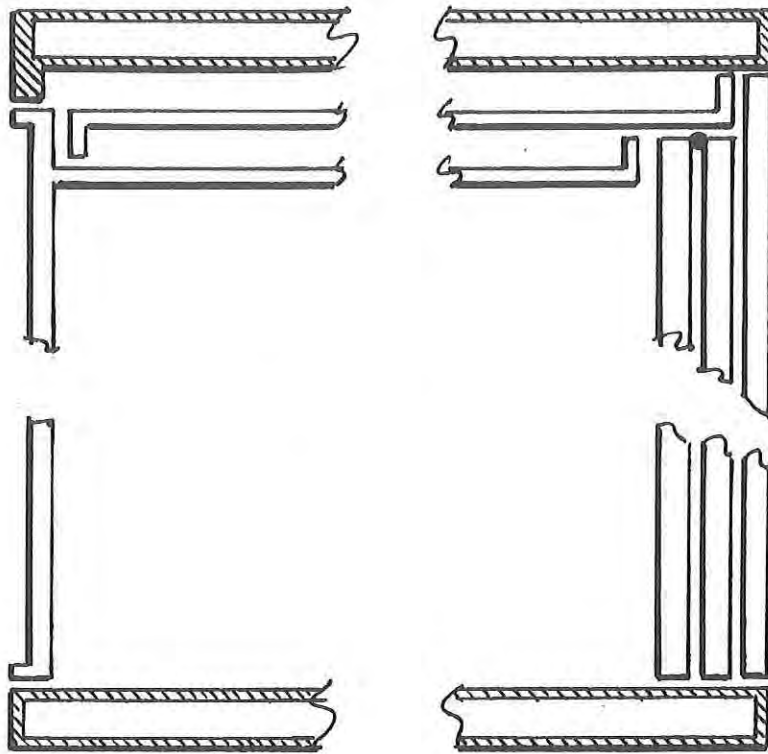

Figure 58. Longitudinal Section, Container Mode

- c. Expanding modules are rolled out on expansion tracks
- d. Floors swing out from storage position
- e. Locking devices secure components

### 3. Utilization of Interior

#### Access:

Container - 6-2/3' double door in side  
 Shelter - 6-2/3' double door in side

#### Attachments:

Container - fixed	-	floor, sides, end, roof
temporary	-	floor, sides, end, roof
Shelter - fixed	-	access side wall
temporary	-	floor, expanding outer floor top, access side wall

Mechanical - Access side wall is most likely place for mechanical attachment points.

#### 4. Joinery

Airtight, relatively watertight shelter is possible. Problem areas are mechanisms for expansion, weather-seals between components.

Configuration F - This two-sided, double telescoping split-frame configuration may be produced in plastic by injection molding or thermoforming large components.

#### 1. Components (Figure 59.)

- 3 Frame sizes
- 9 Shelter Modules
- 3 Pallet sizes
- 1 Common 6-2/3' double access door
- 6 Floor sizes
- 1 Expansion Track
- 1 Universal Leveling Device

---

24 Major Basic Components

#### 2. Expansion Procedure (Figures 60, 61.)

- a. Shelter core is leveled on jack standards
- b. Expansion tracks and leveling devices are attached, located and leveled
- c. Shelter halves are separated and rolled apart on tracks, telescoping to limit
- d. Floor panels swing into place. Access side has folding floor
- e. Locking devices secure components.

#### 3. Utilization of Interior

Access:

Container - Side access through 6-2/3' double doors.  
Shelter - Side access through 6-2/3' double doors.

Attachments

Container - fixed	-	floor, sides, ends, roof
temporary	-	floor, sides, ends, roof
Shelter - fixed	-	floor, ends, roof
temporary	-	floor, ends, roof, expandable floor bottoms

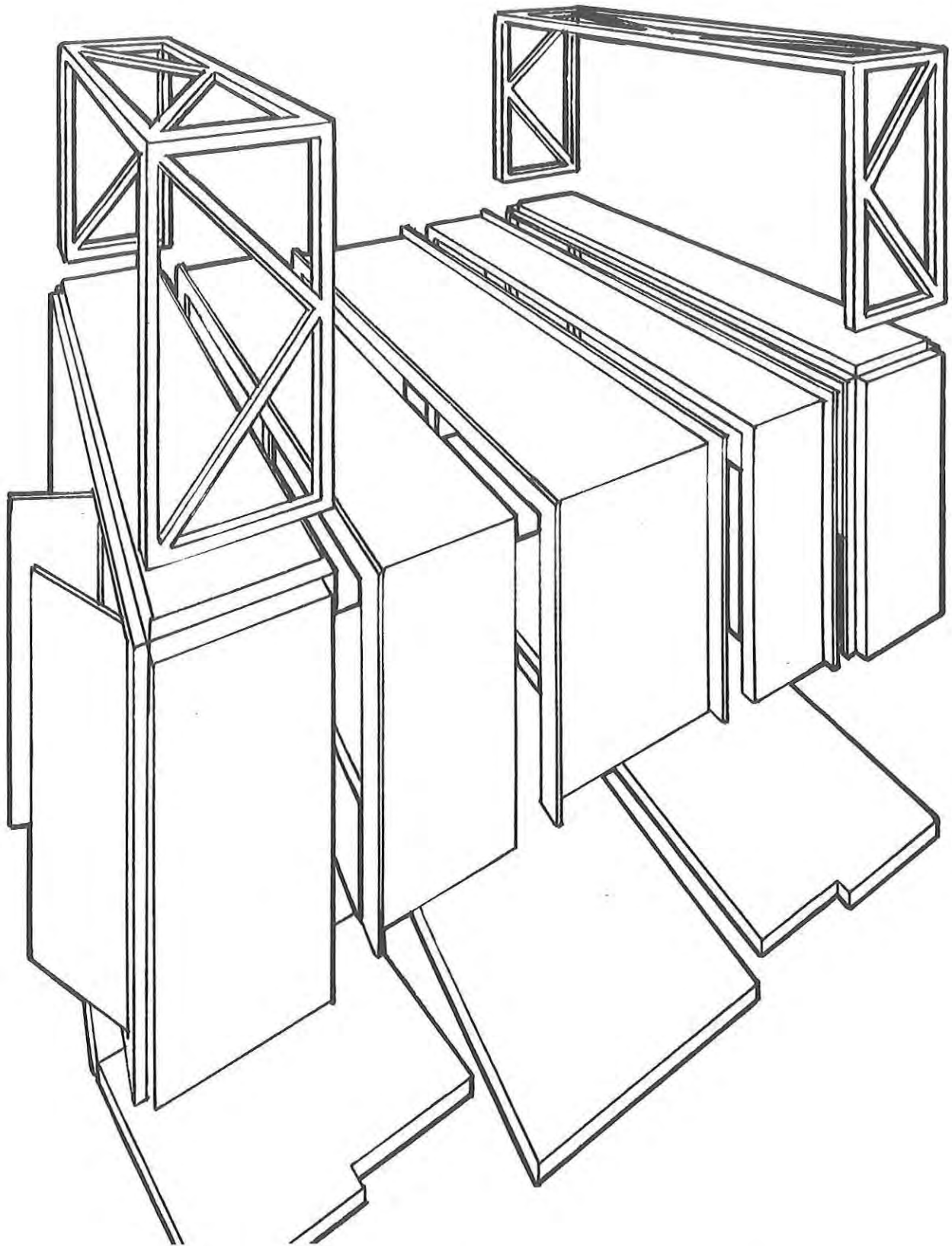

Figure 59. Configuration F

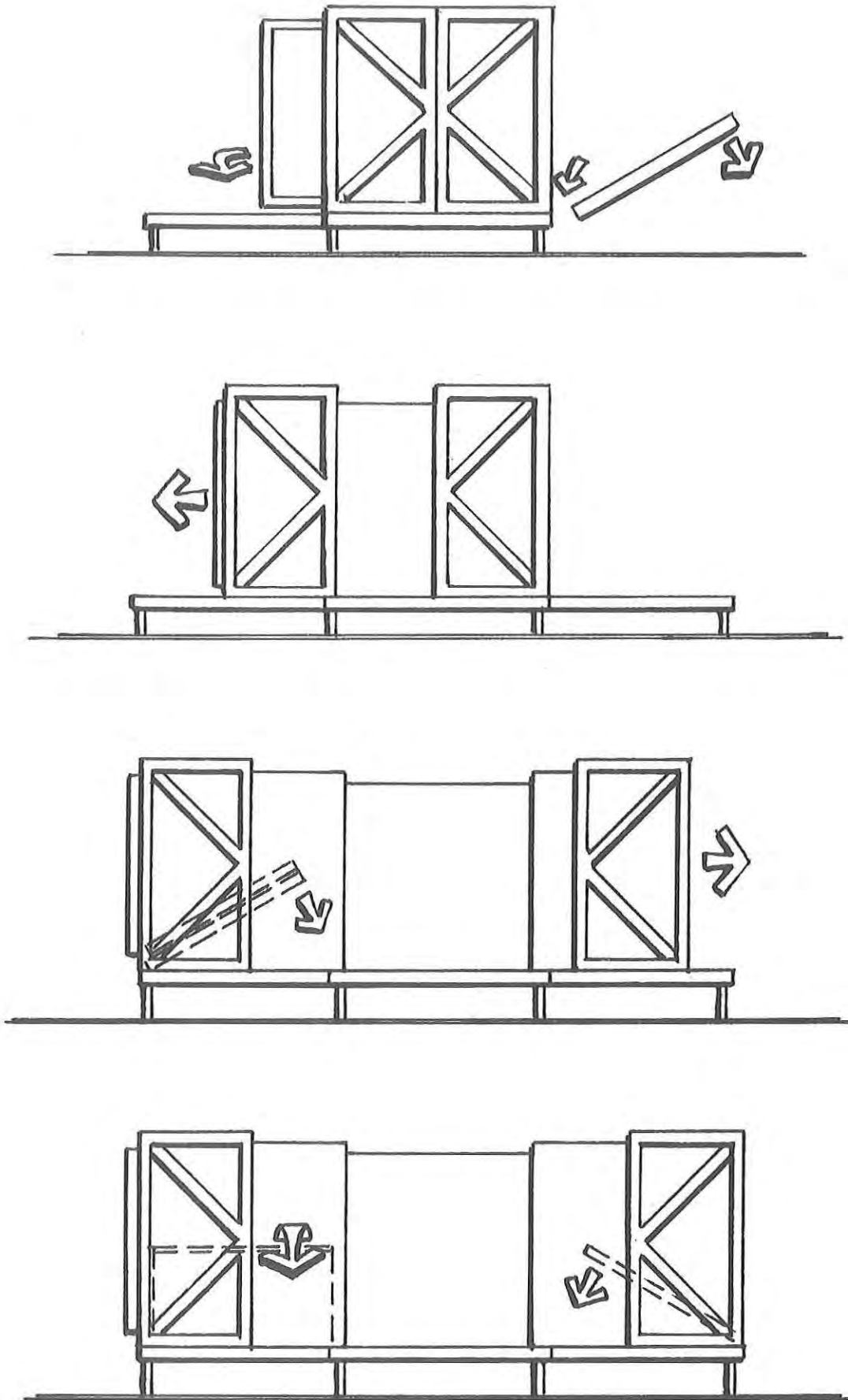

Figure 60. Expansion Procedure

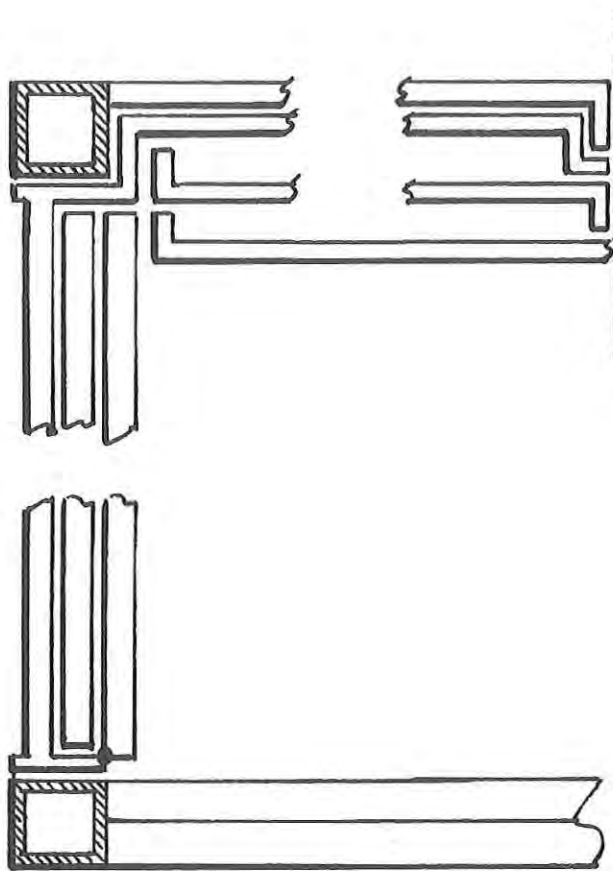

Figure 61. Longitudinal Section, Container Mode

Mechanical

- core end wall is likely location for mechanical attachment - usable only in expanded mode.

#### 4. Joinery

Airtight, watertight shelter may be produced. Problem areas are in expansion mechanisms, securely joining split frame halves, much weathersealing.

Configuration G - This split-frame panel system may be produced with conventional sandwich panel materials and processes or in plastic by injection molding or thermoforming the components.

#### 1. Components (Figure 62.)

- 3 Frame sizes, using common parts
- 2 Floor panel sizes (3-1/3', 6-2/3')
- 2 Side wall and roof panel sizes (3-1/3', 6-2/3')

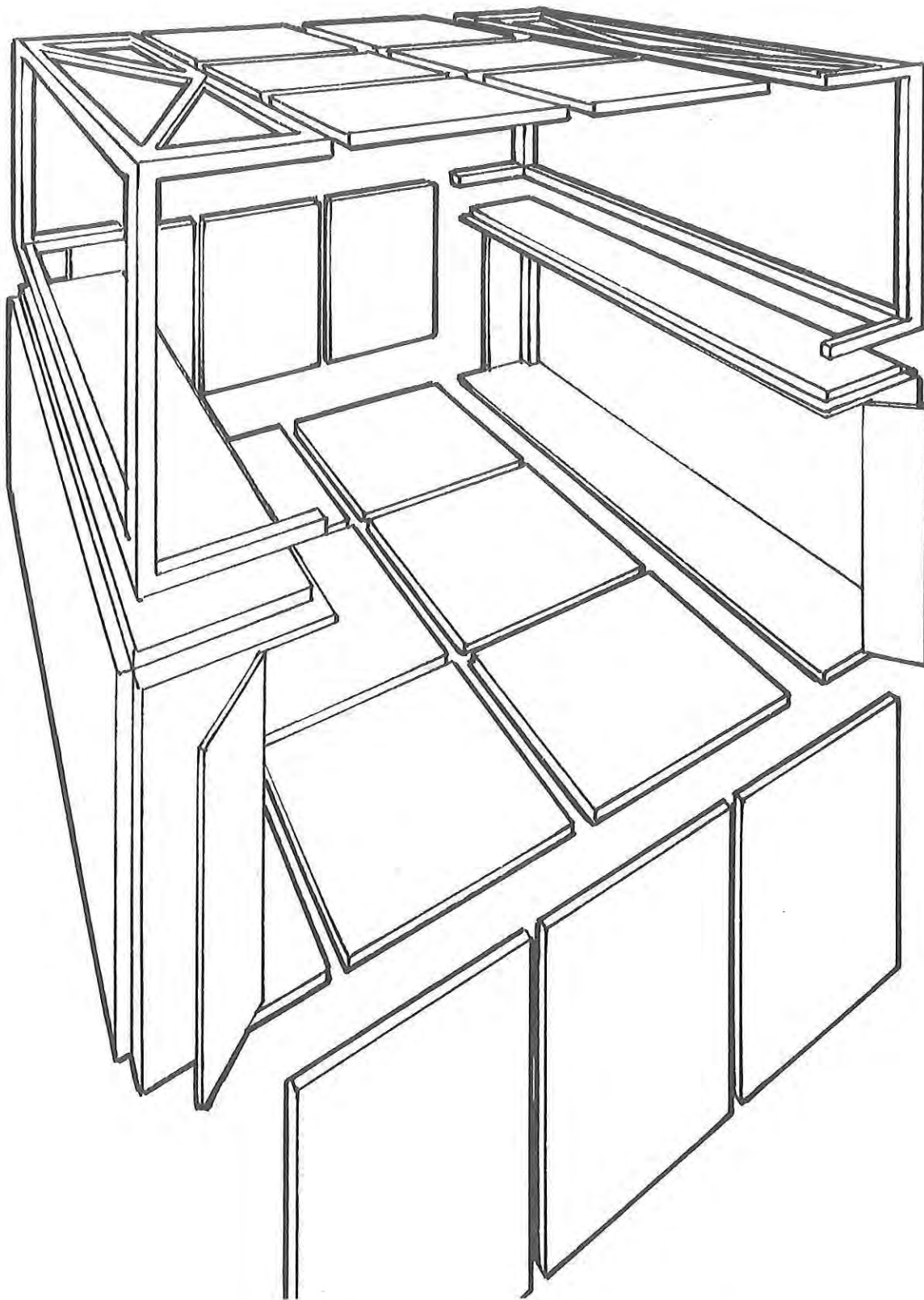

Figure 62. Configuration G

- 3 ½ Core Modules
- 1 Expansion Track
- 1 Universal leveling device
- 1 Common door panel

---

13 Major Basic Components

2. Expansion Procedure (Figures 63, 64.)
  - a. Shelter core is leveled on jack standards
  - b. Expansion tracks are set up and leveled on jack standards
  - c. Core halves are separated, expanding side is rolled out to position
  - d. Floor panels are positioned and leveled by supporting jack standards
  - e. Floor panels are secured
  - f. Roof panels are raised and secured
  - g. Wall panels are positioned and secured.

3. Utilization of Interior

Access:

- Container - end ½ doors
- Shelter - end ½ doors - doors in wall panels

Attachments:

- Container - fixed - floor, sides, end, roof
- temporary - floor, sides, end, roof
- Shelter - fixed - sides
- temporary - sides

- Mechanical - Core ½ sides provide best location for mechanical attachment.

4. Joinery

Much joinery and weathersealing is required. Expansion mechanics presents further problems.

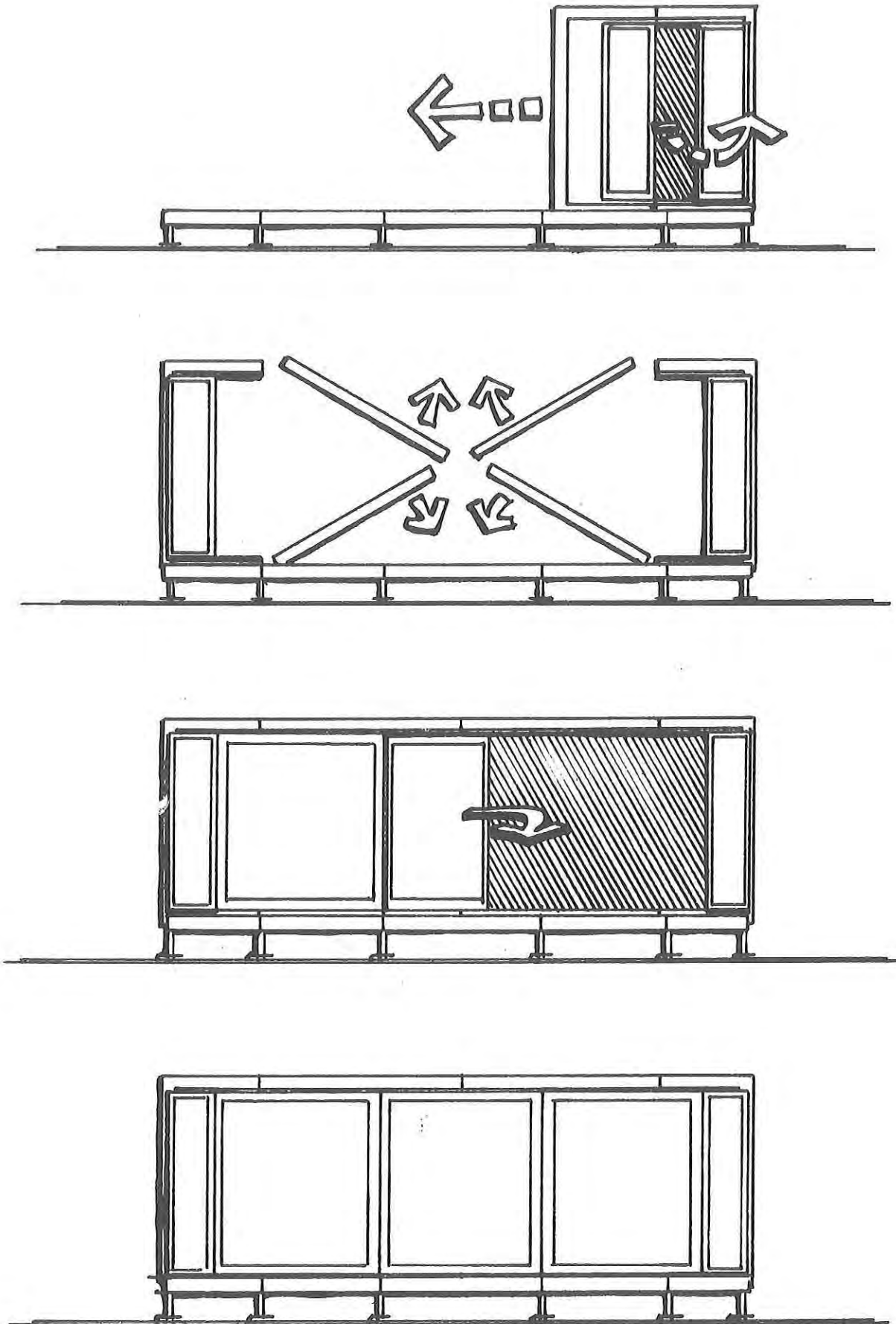

Figure 63. Expansion Procedure

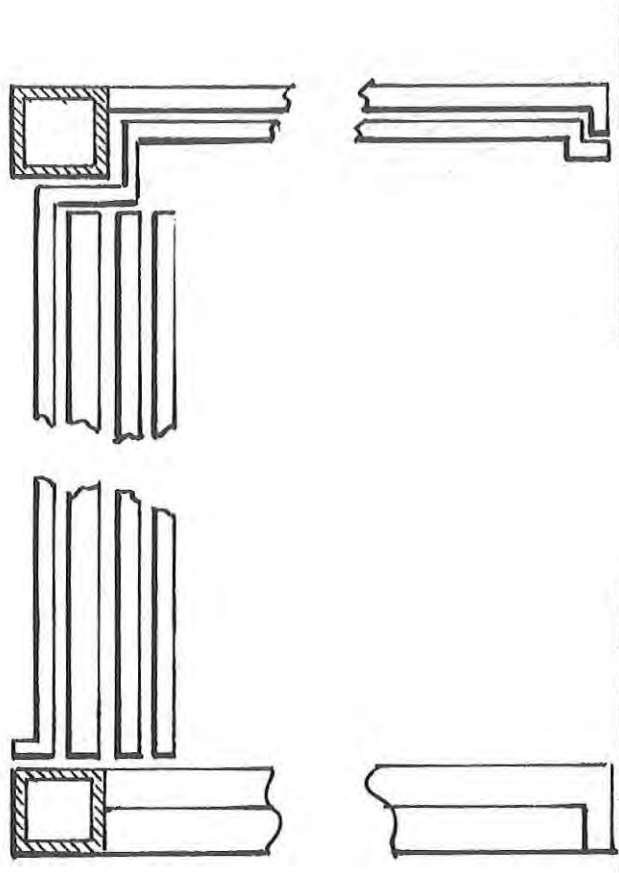

Figure 64. Longitudinal Section, Container Mode

Configuration H - This parallelogram expandable panel configuration may be produced by injection molding or thermoforming specially designed panels.

1. Components (Figure 65.)

- 3 Frame sizes, using common parts
- 3 Pallet sizes
- 3 Floor sizes
- 3 Sidewalls
- 3 Roofs
- 3 Cores
- 1 Folding end wall
- 1 Common double cargo/personnel door
- 1 Common expansion track
- 1 Leveling device

---

22 Major Basic Components

2. Expansion Procedure (Figures 66, 67.)

- a. Shelter core is leveled on jack standards

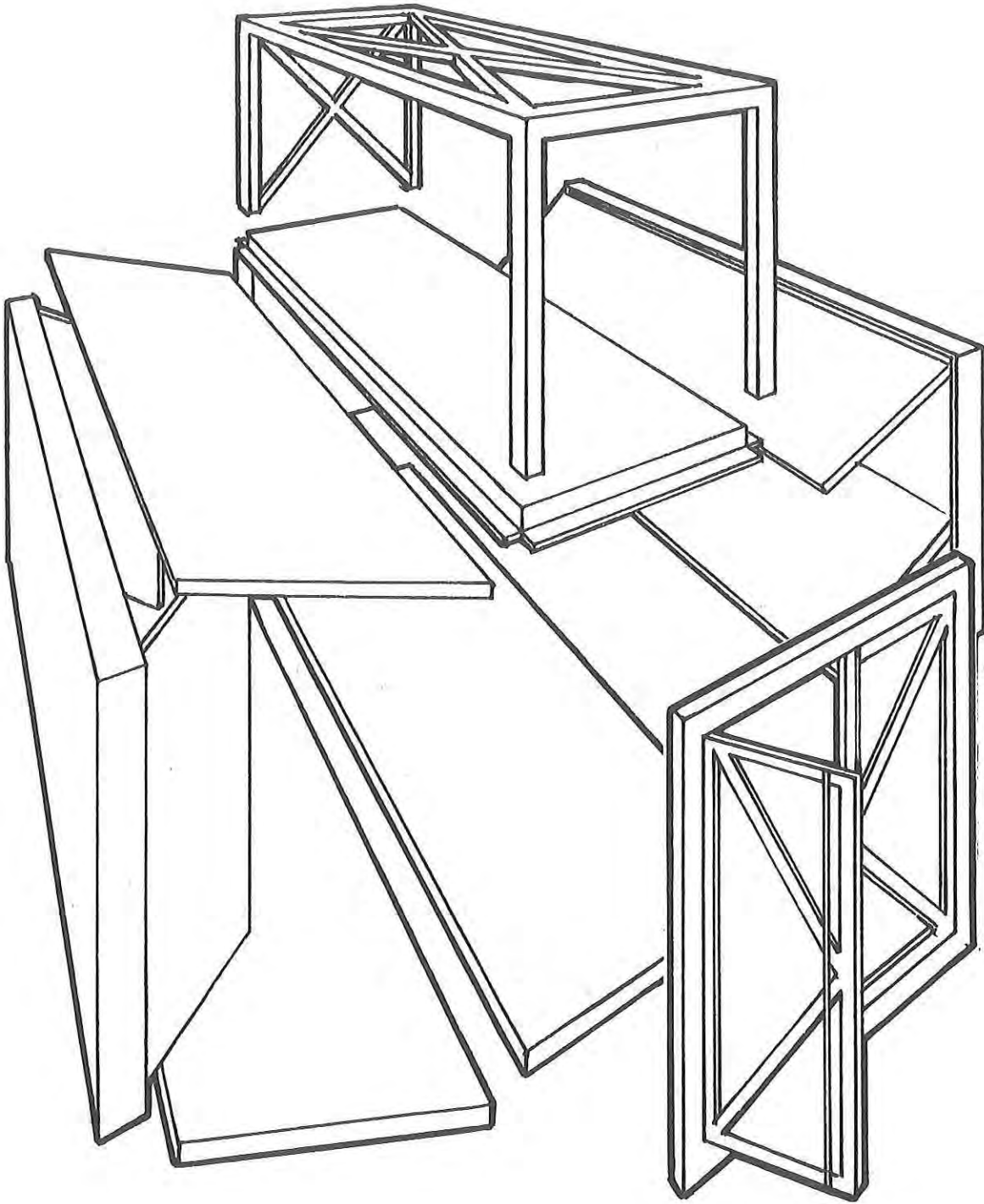

Figure 65. Configuration H

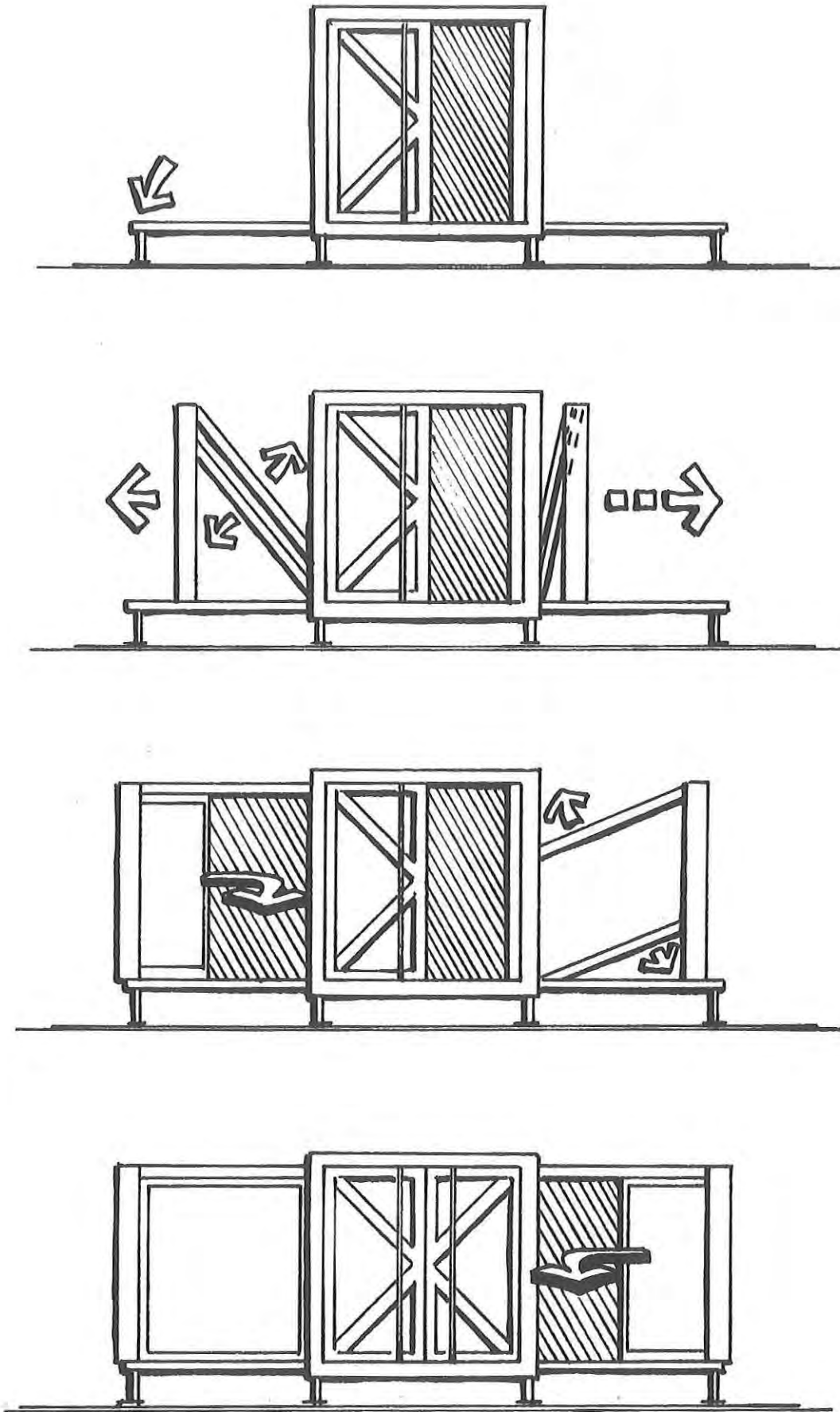

Figure 66. Expansion Procedure

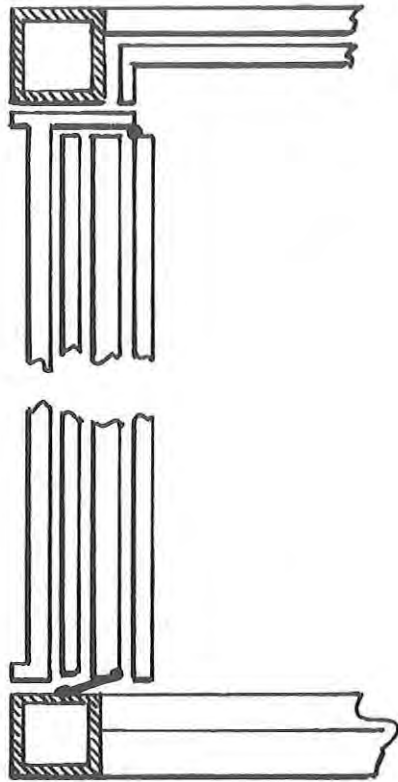

Figure 67. Longitudinal Section, Container Mode

- b. Expansion tracks are located and leveled
- c. Side-walls are drawn out causing roof to raise and floor to drop simultaneously
- d. End walls unfold from storage position in side wall
- e. Locking devices secure components.

### 3. Utilization of Interior

#### Access:

- Container - double cargo door in end
- Shelter - double cargo door in end; additional access thru folding end walls - possible personnel doors in side walls, usable only in shelter mode.

#### Attachments:

- Container - fixed - floor, sides, end, roof
- temporary - floor, sides, end roof
- Shelter - fixed - floor, end wall, roof
- temporary - floor, end, roof, expanding roof top

Mechanical

- Shelter core end wall is best location for mechanical attachments.

#### 4. Joinery

Airtight, watertight shelter may be produced. Expansion tracks and slides for floor and roof panels presents some mechanical problems.

Configuration I - This folding panel system may be produced either by conventional sandwich panel technology or by injection molding or thermoforming specially designed panels.

#### 1. Components (Figure 68.)

- 3 Frame sizes, using common parts
- 3 Pallet sizes
- 3 Roof side Pan sizes
- 3 Side wall sizes
- 3 Floor sizes
- 1 End wall
- 1 Common double cargo door
- 1 Universal leveling device

---

18 Major Basic Components

#### 2. Erection Procedure (Figures 69, 70.)

- a. Shelter core is leveled on jack standards
- b. Side wall roof pan is raised into position, supported by a dead man
- c. Floor panel is swung out from storage and leveled on standards
- d. Shelter side wall is lowered from roof pan and secured to floor panel
- e. End walls are lowered from roof pan and secured to floor panel.
- f. Dead-man support is removed.

#### 3. Utilization of Interior

Access:

- Container - end access through double cargo doors
- Shelter - end access through double cargo doors. Additional access through possible personnel doors in wall panels.

Attachments:

- Container - fixed: floor, sides, end, roof

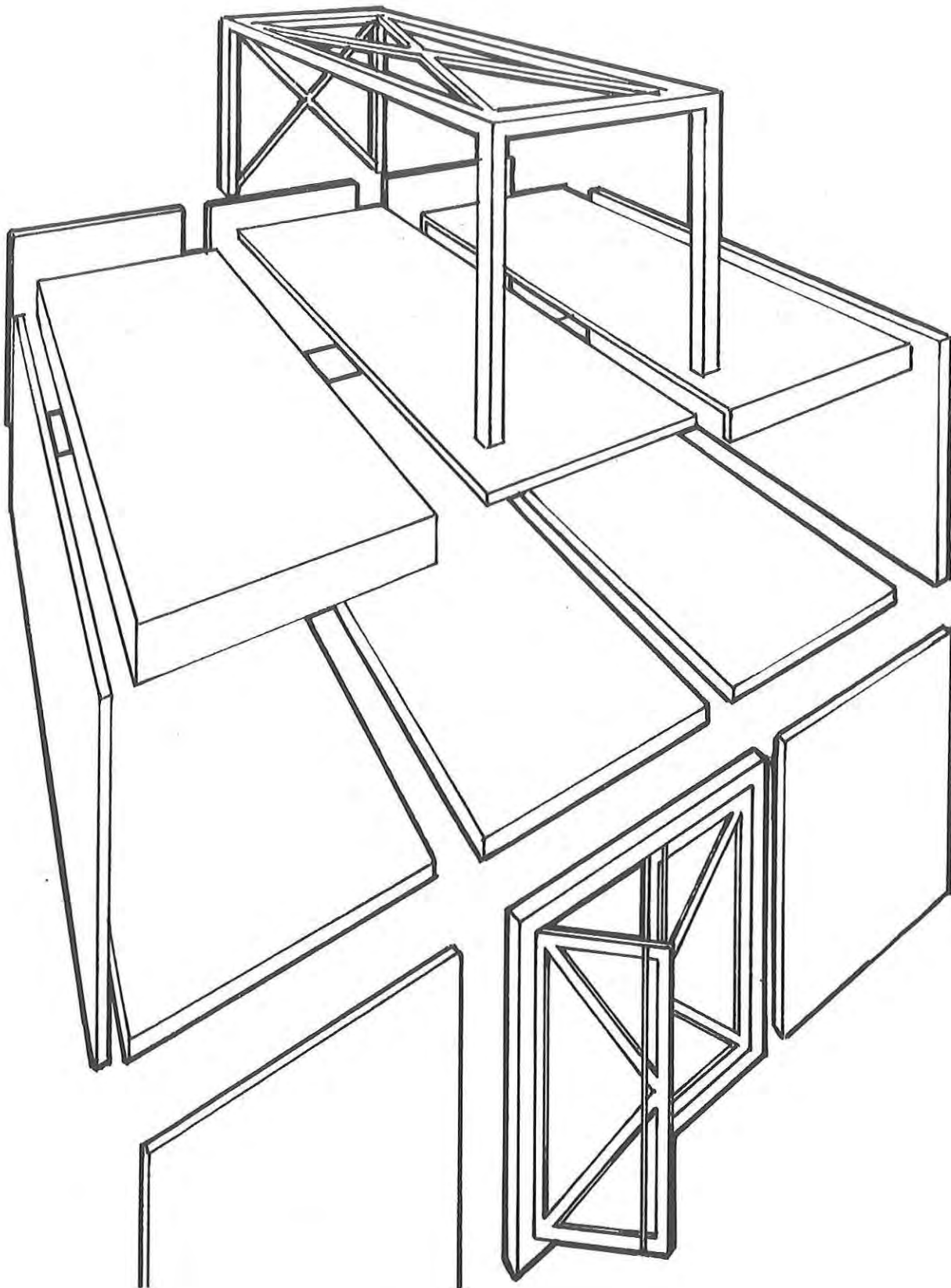

Figure 68. Configuration I

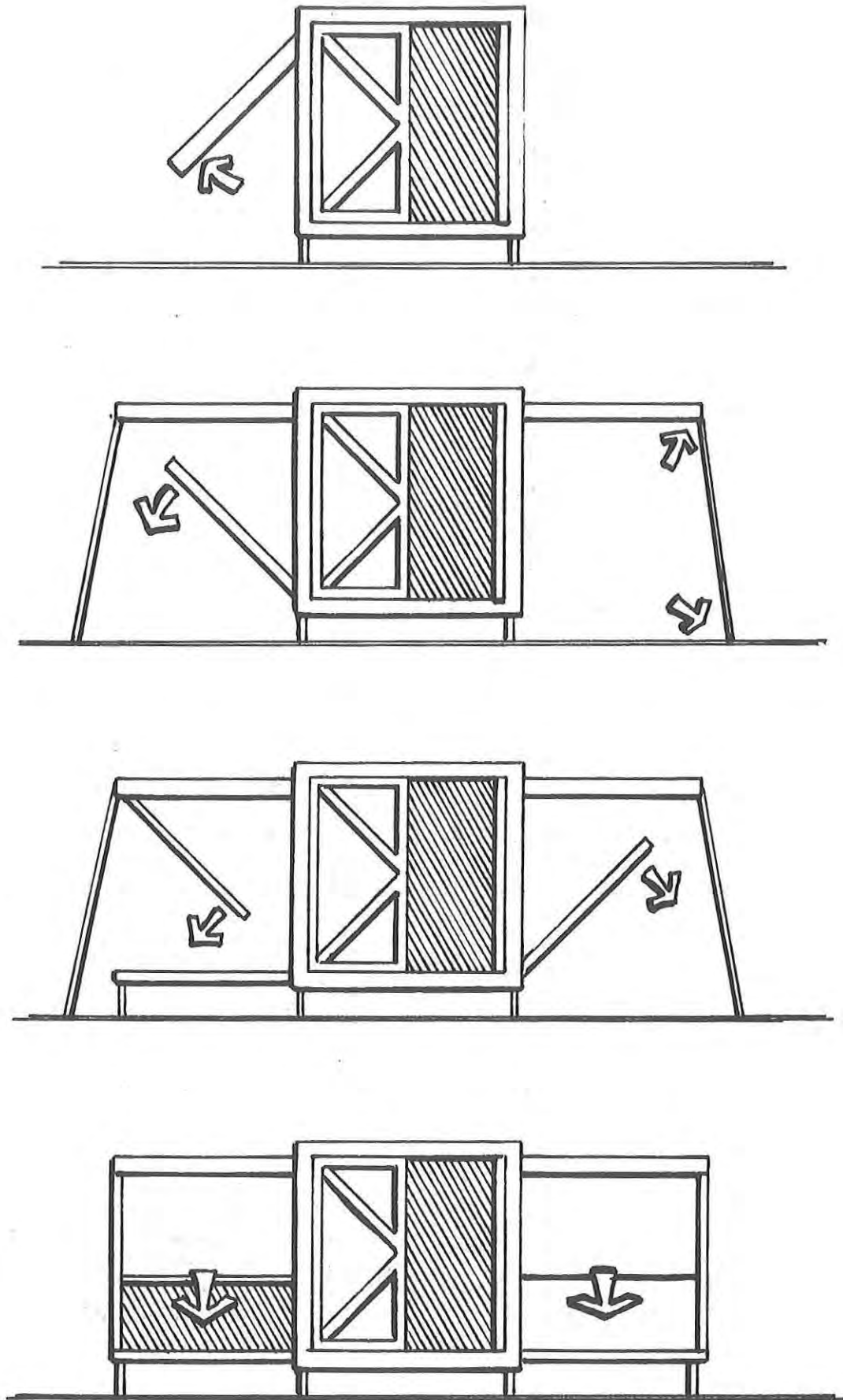

Figure 69. Expansion Procedure

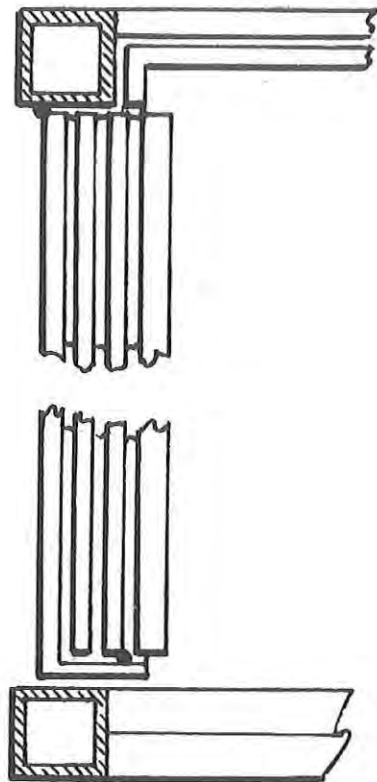

Figure 70. Longitudinal Section, Container Mode

	temporary:	floor, sides, end, roof
Shelter - fixed	:	floor, end, roof
	temporary:	floor, end, roof, tops of expanding floors
Mechanical	:	Core end wall is most likely location for mechanical attachments.

#### 4. Joinery

Airtight, watertight shelter can be made. No major problems foreseen.

Configuration J - The core of this accordion-type expandable configuration may be rotomolded, injection molded, thermoformed, or constructed of sandwich panels. It is speculative that expanding modules may be produced by sophisticated injection molding or rotomolding techniques, or more feasibly by conventional panel joinery methods.

1. Components (Figure 71.)

- 3 Frame sizes, using common parts
- 3 Pallet sizes
- 3 Floor sizes
- 3 Side wall sizes
- 1 Common access door
- 3 Core modules
- 1 Expanding module
- 1 Universal Leveling Device

---

18 Major Basic Components

2. Erection Procedure (Figures 72, & 73.)

- a. Shelter core is leveled on jack standards
- b. Expanding floors are lowered and leveled on jack standards
- c. Expanding side walls are raised into position and secured by central roof track beam
- d. Accordion-type expanding modules are drawn out and locked in position, sealing the shelter.

3. Utilization of Interior

Access:

- Container - end access through double cargo doors
- Shelter - end access through double cargo doors; additional access through possible personnel doors in expanded side walls.

Attachments:

- Container - fixed: floor, end, sides, roof
- temporary: floor, end, sides, roof
- Shelter - fixed: floor, end
- temporary: floor, end, side wall

Mechanical : Core end wall presents best location for mechanical outlets.

4. Joinery

Airtight, watertight shelter is possible. Major problem is joinery in accordion expandable modules.

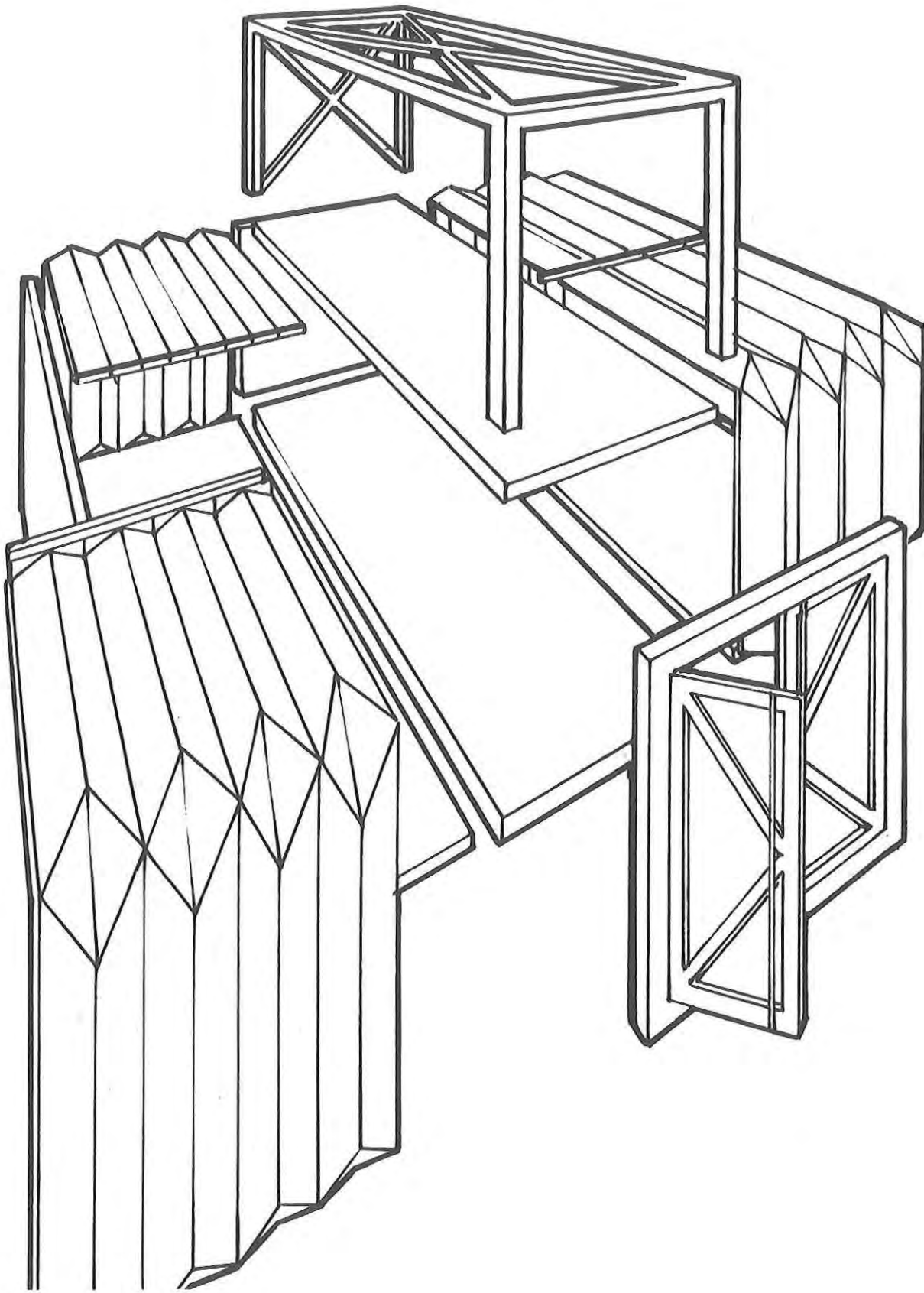

Figure 71. Configuration J

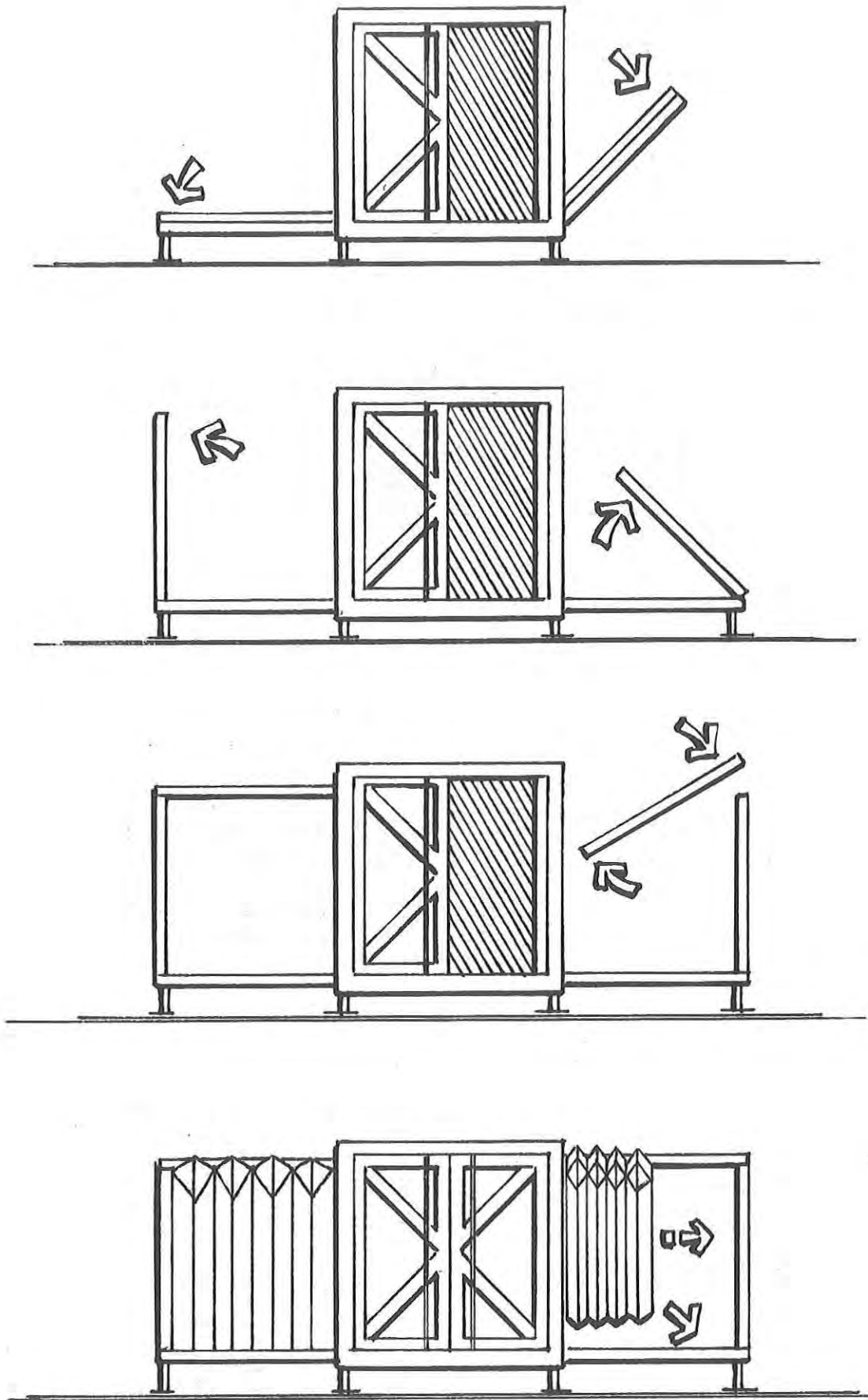

Figure 72. Expansion Procedure

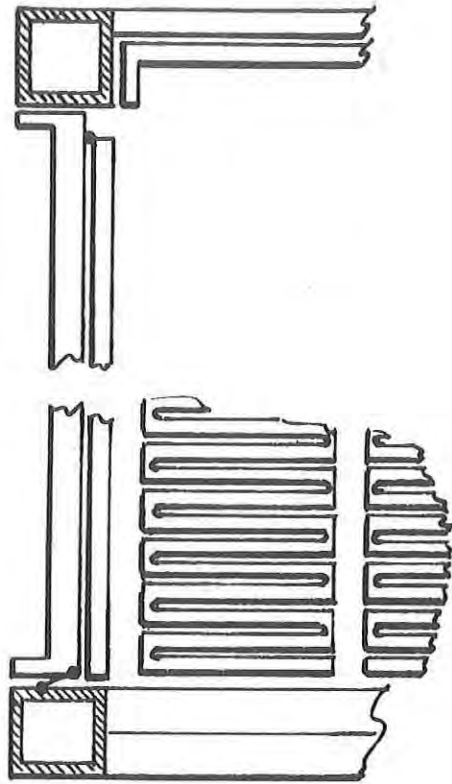

Figure 73. Longitudinal Section, Container Mode

Configuration K - The core of this accordion-type expandable configuration may be rotomolded, injection molded, thermoformed, or constructed of sandwich panels. It is feasible that expanding modules may be produced by conventional panel techniques, or speculative that they may be manufactured by sophisticated injection molding or rotomolding techniques.

1. Components (Figure 74.)

- 3 Frame sizes, using common parts
- 3 Pallet sizes
- 3 Expanding floor sizes (double as core roofs)
- 1 Common access door
- 1 Common expanding end wall (also core end)
- 1 Accordion expandable module
- 1 Universal Leveling Device

---

13 Major Basic Components

2. Erection Procedure (Figures 75 & 76.)

- a. Shelter core is leveled on jack standards
- b. Core side walls are chopped to become shelter floors

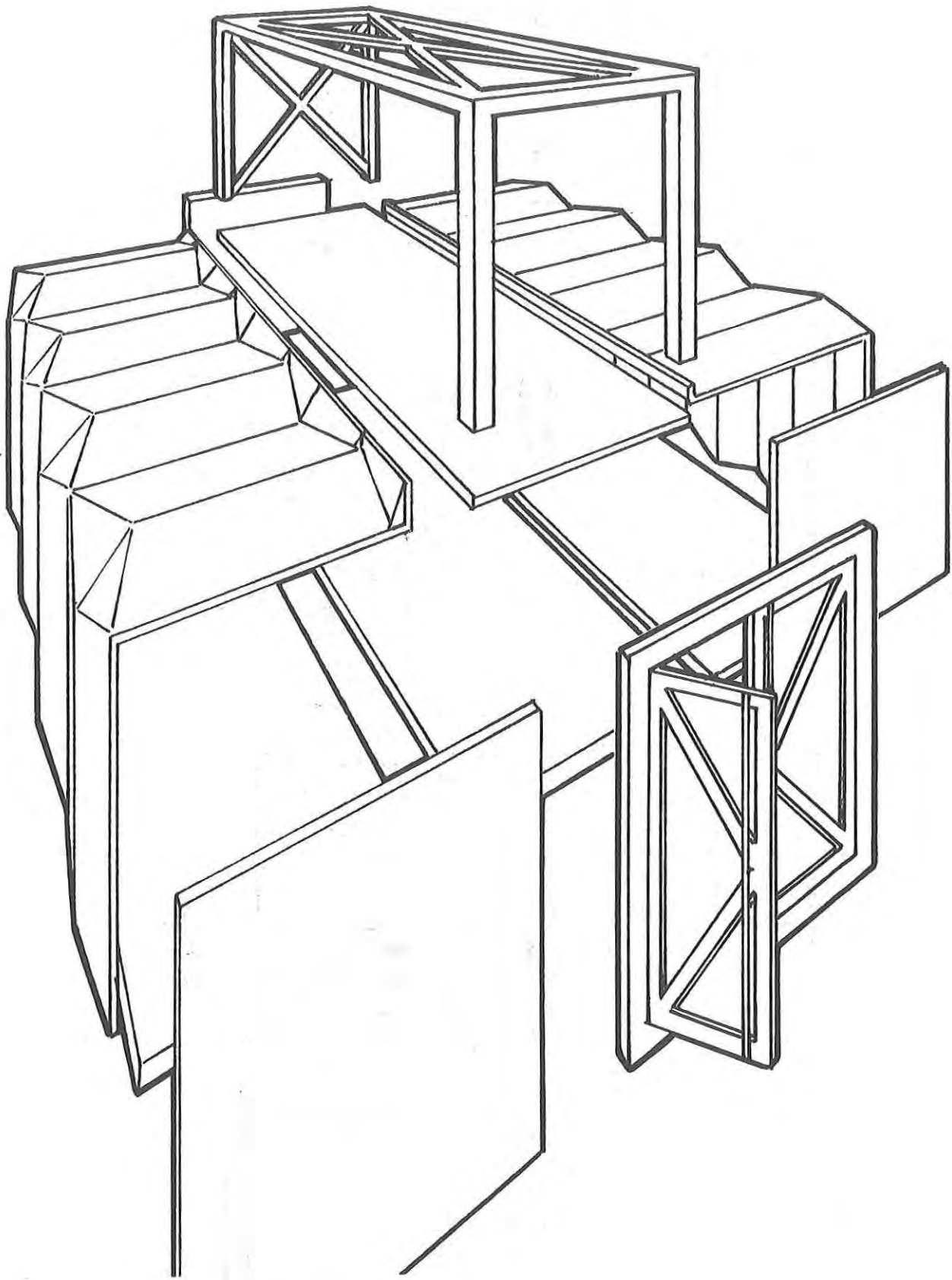

Figure 74. Configuration K

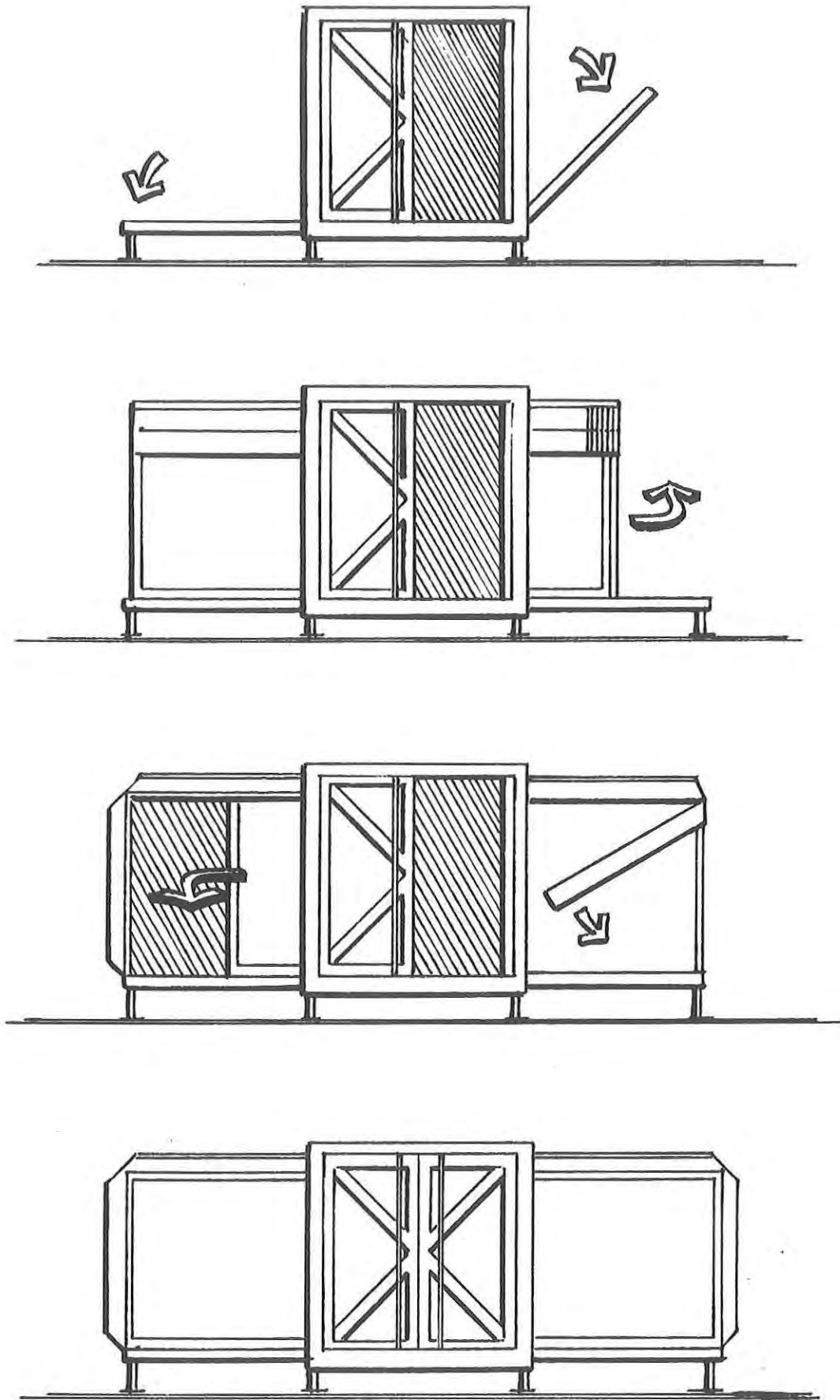

Figure 75. Expansion Procedure

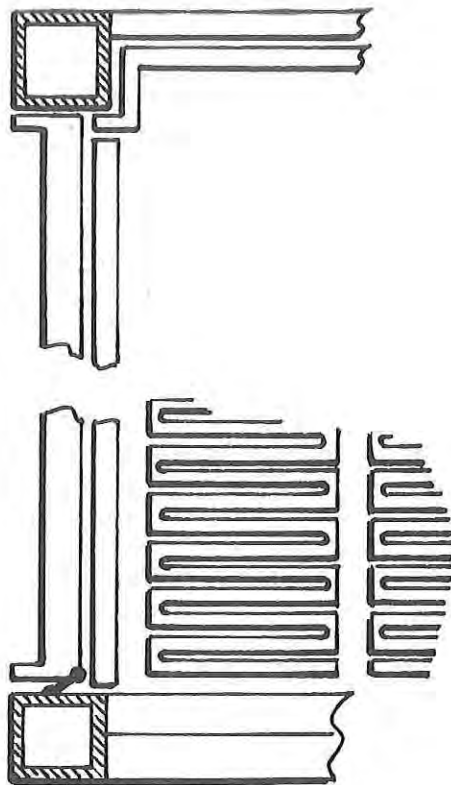

Figure 76. Longitudinal Section, Container Mode

- c. Floors are leveled on jack standards
- d. Expanding end walls are swung into position
- e. Accordion-type expanding module is drawn out from end wall storage position, sliding in track on core, opening and unfolding into final position and secured.
- f. Shelter is sealed with locking devices.

### 3. Utilization of Interior

#### Access:

Container - end access thru double cargo doors  
 Shelter - end access thru double cargo doors;  
 additional access through end walls.

#### Attachments:

Container - fixed: floor, sides, end, roof  
 temporary: floor, sides, end, roof

Shelter - fixed: floor, roof, end  
 temporary: floor, roof, end, top of  
 expanding floor

Mechanical : Core end wall is best location for mechanical outlets.

#### 4. Joinery

Airtight, watertight shelter is feasible. Major joinery problem is weathersealing of many seams in accordion-type module.

Configuration L - The core of this accordion-type expandable configuration is filament wound longitudinally, requiring side access. It is either feasible that expanding modules may be produced by conventional panel techniques or speculative that they may be manufactured by sophisticated injection molding or rotomolding techniques.

#### 1. Components (Figure 77.)

- 3 Core sizes with integral frame
- 4 Floor panel sizes
- 3 Pallet sizes
- 1 Folding end wall
- 1 Basic expandable module
- 1 Common 6-2/3' side access door
- 1 Universal Leveling device

---

14 Major Basic Components

#### 2. Expansion Procedure (Figures 78 & 79.)

- a. Shelter core is leveled on jack stands
- b. Side walls are lowered to become shelter floors, supported by jack standards
- c. End walls are swung into position
- d. Accordion-type expandable is drawn out, unfolding and opening into final position, and secured and sealed.

#### 3. Utilization of Interior

Access:

- Container - 6-2/3' double cargo door in side
- Shelter - 6-2/3' double cargo door in side; additional access possible through expanded end walls.

Attachments:

- Container - fixed: floor, sides, ends, roof
- temporary: floor, sides, ends, roof

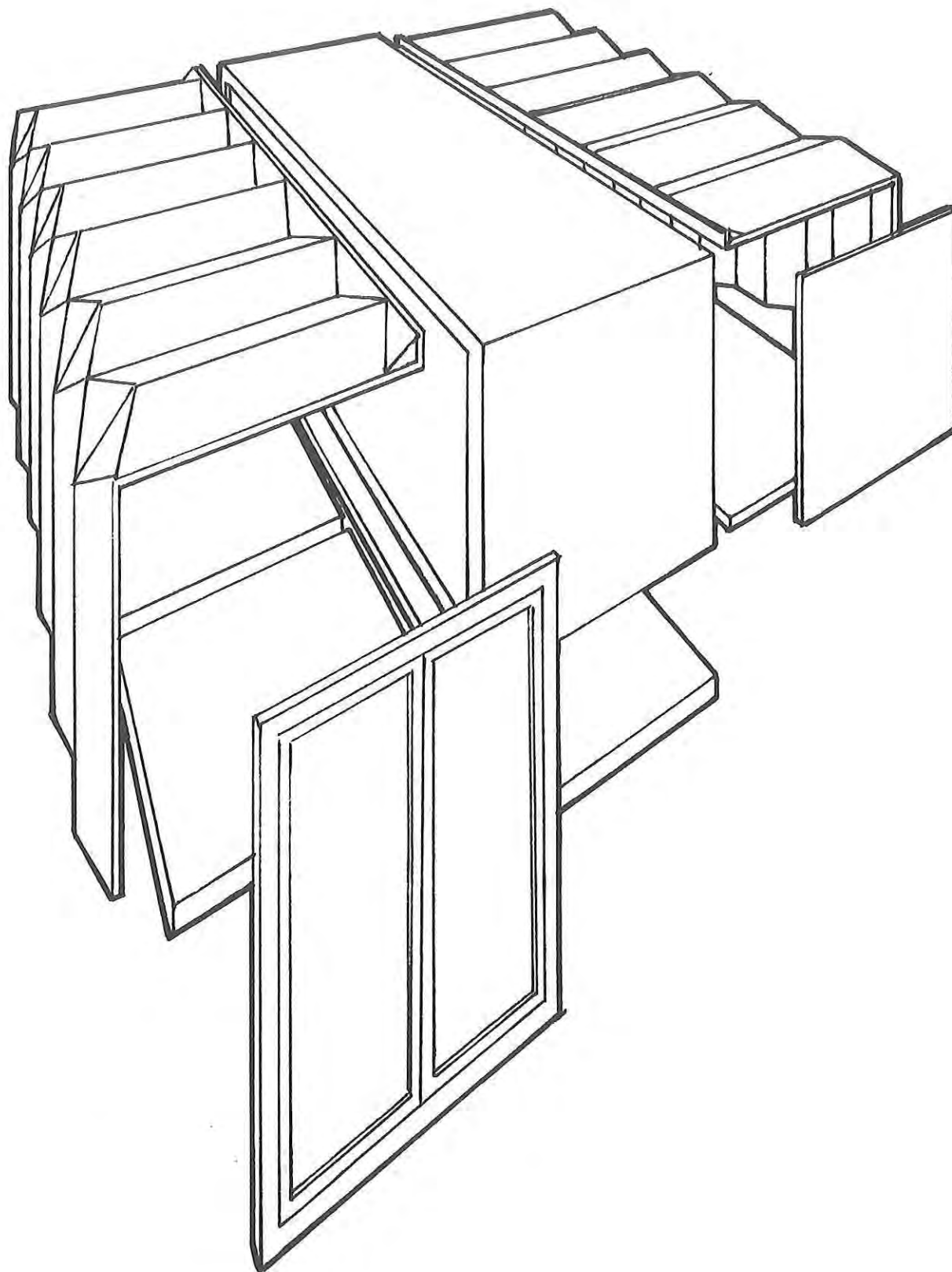

Figure 77. Configuration L

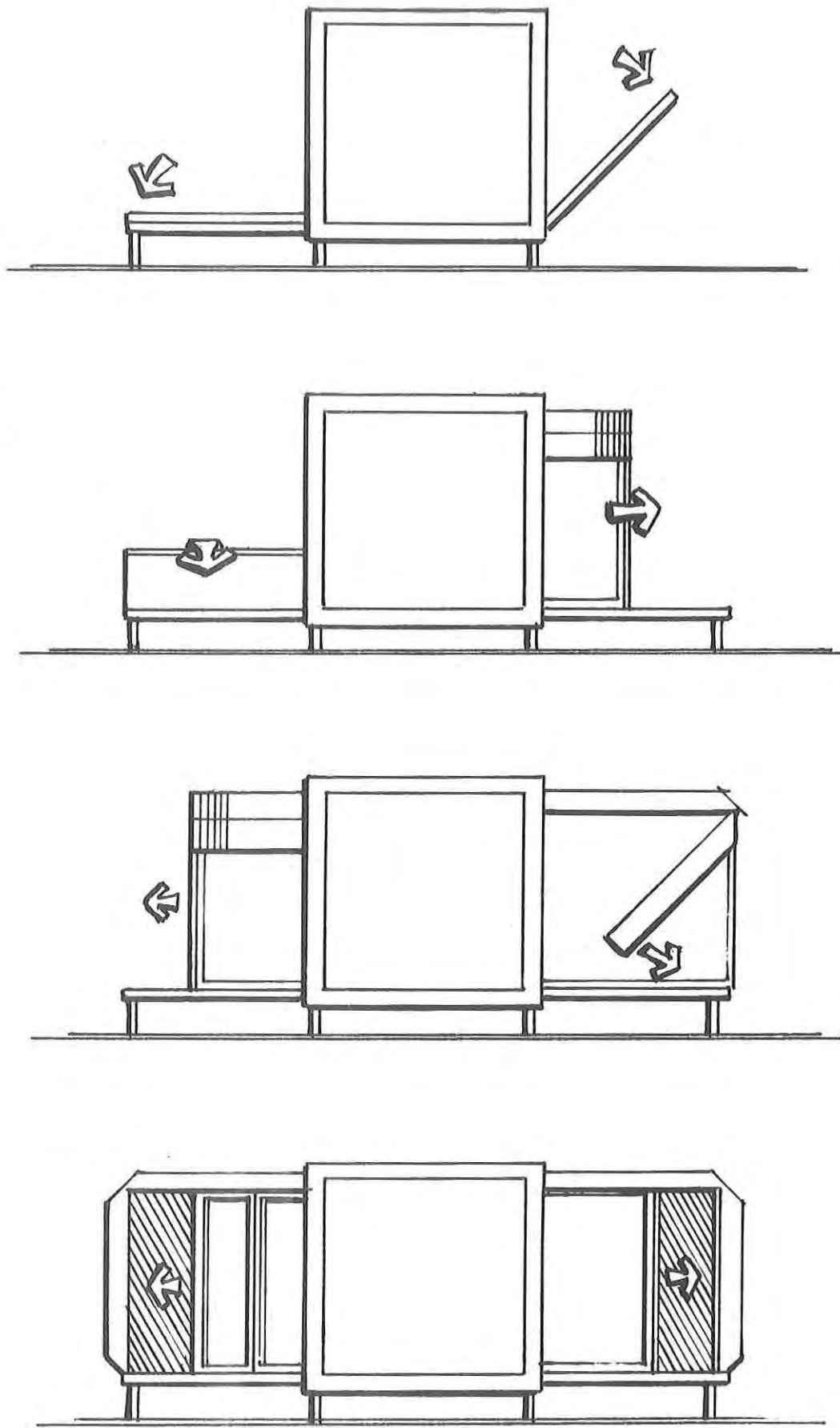

Figure 78. Expansion Procedure

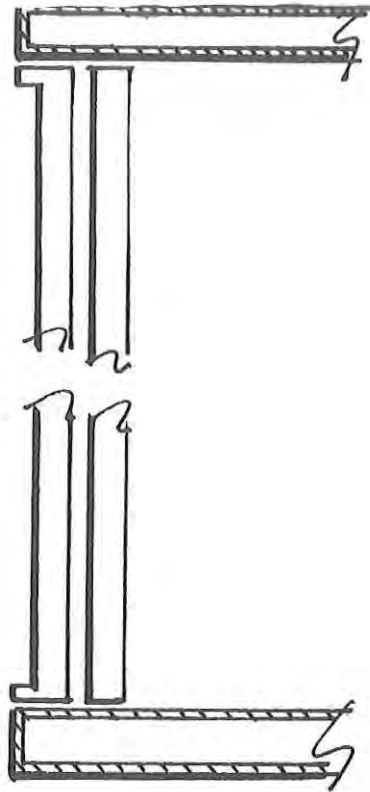

Figure 79. Longitudinal Section, Container Mode

Shelter - fixed: floor, ends, roof  
 temporary: floor, ends, roof, some floor panel faces.

Mechanical : Core end wall is best location for mechanical connections.

#### 4. Joinery

Airtight, watertight shelter is feasible. Major joinery problem is weathersealing of many seams in accordion-type module.

Configuration M - Core is manufactured by filament winding or by modular injection molded or thermoformed components. Expanding components are produced by conventional sandwich panel technology.

#### 1. Components (Figure 80.)

##### a. Filament Wound

3 Core sizes with integral frame

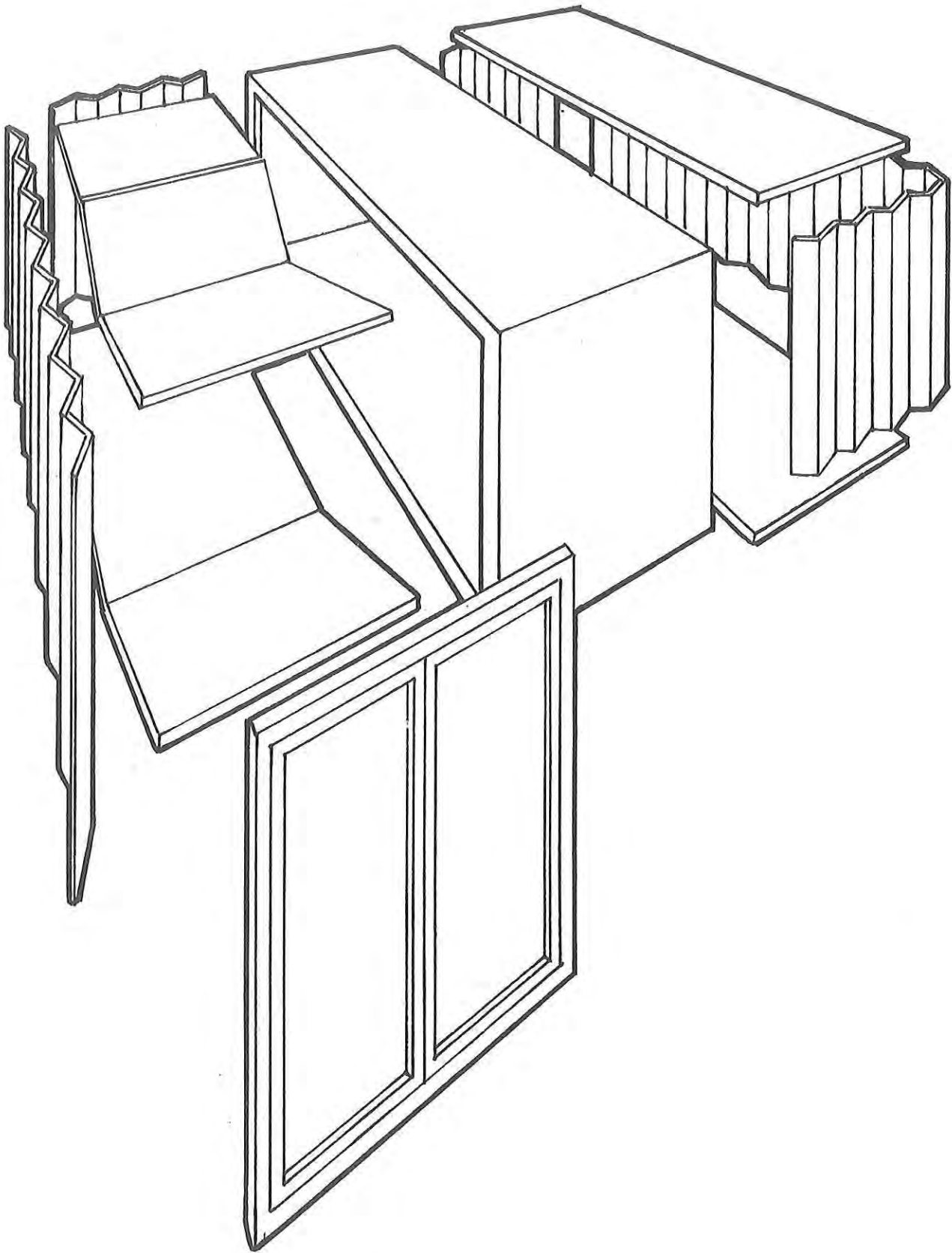

Figure 80. Configuration M

- 3 Pallet sizes
- 1 Expanding Wall module
- 4 Floor panel sizes
- 4 Roof panel sizes
- 1 Universal Leveling Device
- 1 Common 6-2/3' Access Door

---

17 Major Basic Components

b. Injection molded

- 3 Frame sizes, using common parts
- 1 Core end module
- 2 Core roof modules
- 3 Pallet sizes
- 1 Expanding wall module
- 4 Floor panel sizes
- 4 Roof panel sizes
- 1 Universal Leveling Device
- 1 Common 6-2/3' Access door

---

20 Major Basic Components

2. Expansion Procedure (Figures 81 & 82.)

- a. Shelter core is leveled on jack standards
- b. Side walls are swung down and, where required, unfold to full length
- c. Expanded floors are leveled on jack standards
- d. Roof panels are raised and unfolded
- e. Folding wall panels are installed and sealed
- f. Access end wall is swung out and locked into position.

3. Utilization of Interior

Access:

- Container - side access thru 6-2/3' double door
- Shelter - side access thru 6-2/3' double door;  
end access in expanded mode.

Attachments:

- Container - fixed: floor, ends, sides, roof
- temporary: floor, ends, sides roof
- Shelter - fixed: floor, ends, roof
- temporary: floor, ends, roof, some side panel faces.

Mechanical : Core end wall is best location for mechanical outlets.

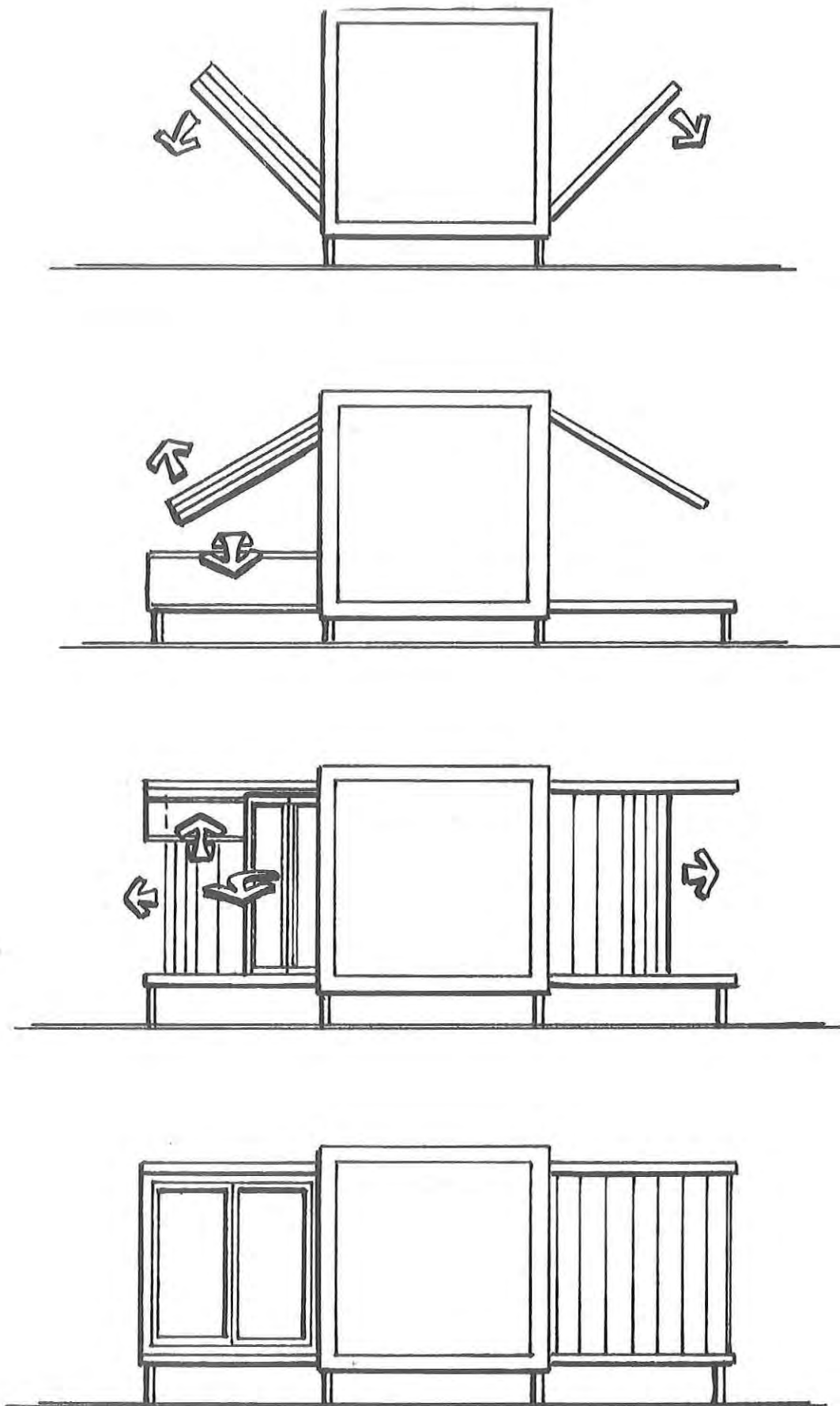

Figure 81. Expansion Procedure

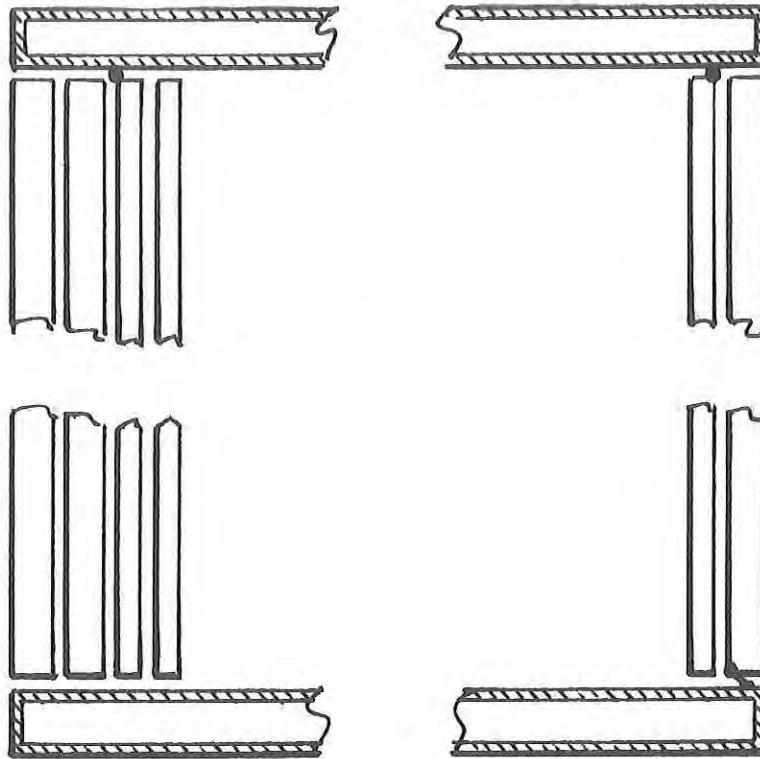

Figure 82. Longitudinal Section, Container Mode

#### 4. Joinery

Airtight, watertight shelter is possible. Major problem areas are seams in expanding walls and weathersealing joints between folding roof panels.

Configuration N - Core is rotomolded composite with cut-out sides which become roof panels in expanded mode. Additional panels are conventional sandwich panel alternatives.

#### 1. Components (Figure 83.)

- 3 Basic core sizes with molded-in frame  
- all with or without cut-out sides
  - 3 Pallet sizes
  - 3 Floor sizes
  - 1 Expanding wall module
  - 1 Common access door
  - 1 Universal leveling device
- 
- 12 Major Basic Components

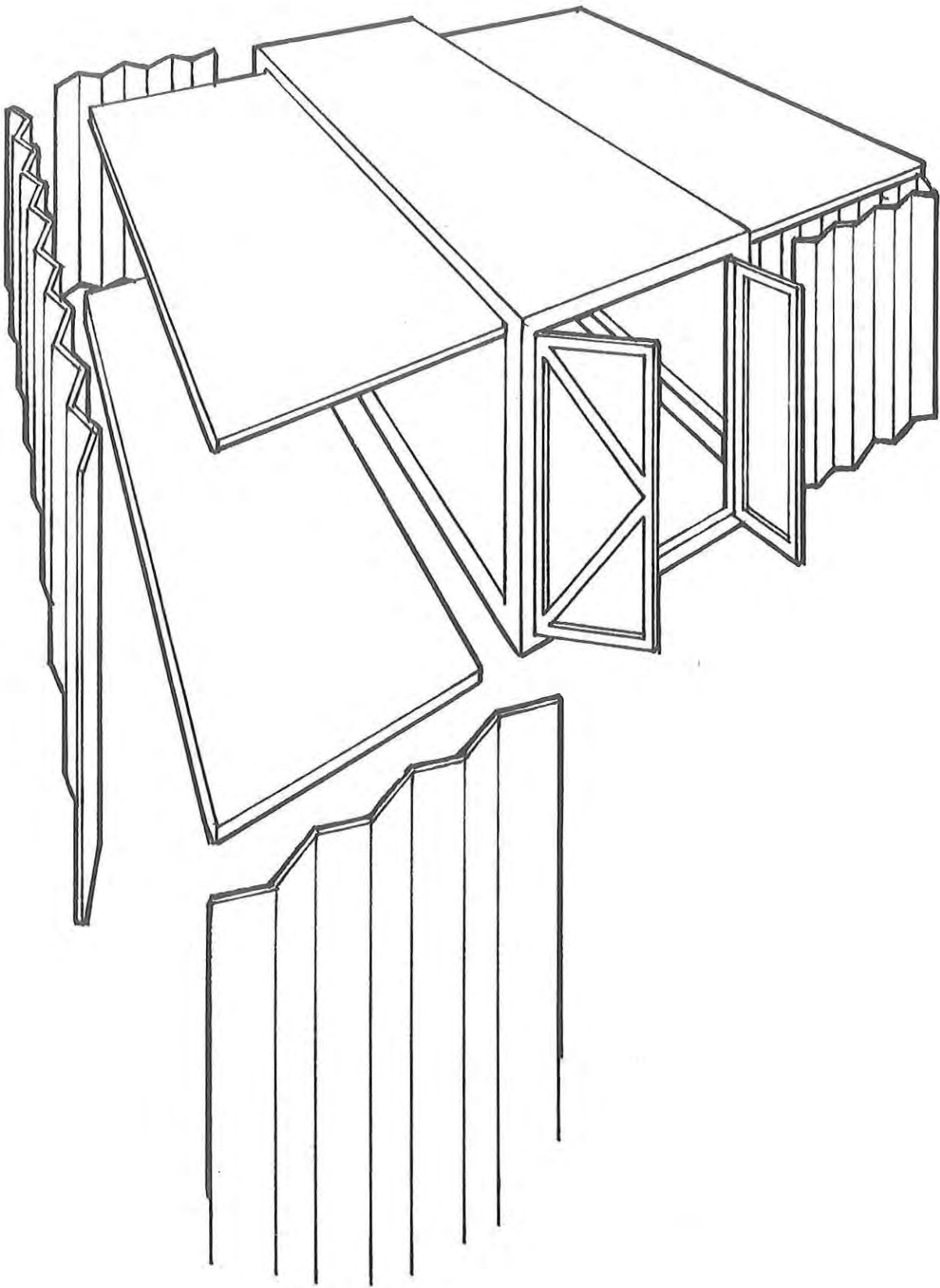

Figure 83. Configuration N

2. Expansion Procedure (Figures 84 & 85.)
  - a. Core is leveled on jack standards
  - b. Side walls are raised to become shelter roof panels; temporarily supported by attached brace.
  - c. Floors are lowered and leveled on jack standards.
  - d. Expanding walls are unfolded and secured in position.

3. Utilization of Interior

Access:

Container - double cargo door in end  
 Shelter - double cargo door in end

Attachments:

Container - fixed: floor, sides, end, roof  
 temporary: floor, sides, end, roof

Shelter - fixed: floor, end, roof  
 temporary: floor, end, floor, tops of expanding floors

Mechanical : Shelter core end wall provides best mechanical outlet attachment point.

4. Joinery

Airtight, watertight shelter is possible. Probable problem area is seams between expanding wall modules and weathersealing wall to floor and roof.

Configuration 0 - This single-sided expandable configuration has a filament wound core with integral frame. Expanding components are produced by conventional sandwich panel techniques.

1. Components (Figure 86.)

3 Core sizes, with integral frame  
 3 Pallet sizes  
 3 Floor sizes  
 3 Roof sizes  
 2 Core side walls  
 1 Common Access Door  
 1 Expandable wall module  
 1 Universal leveling device

---

17 Major Basic Components

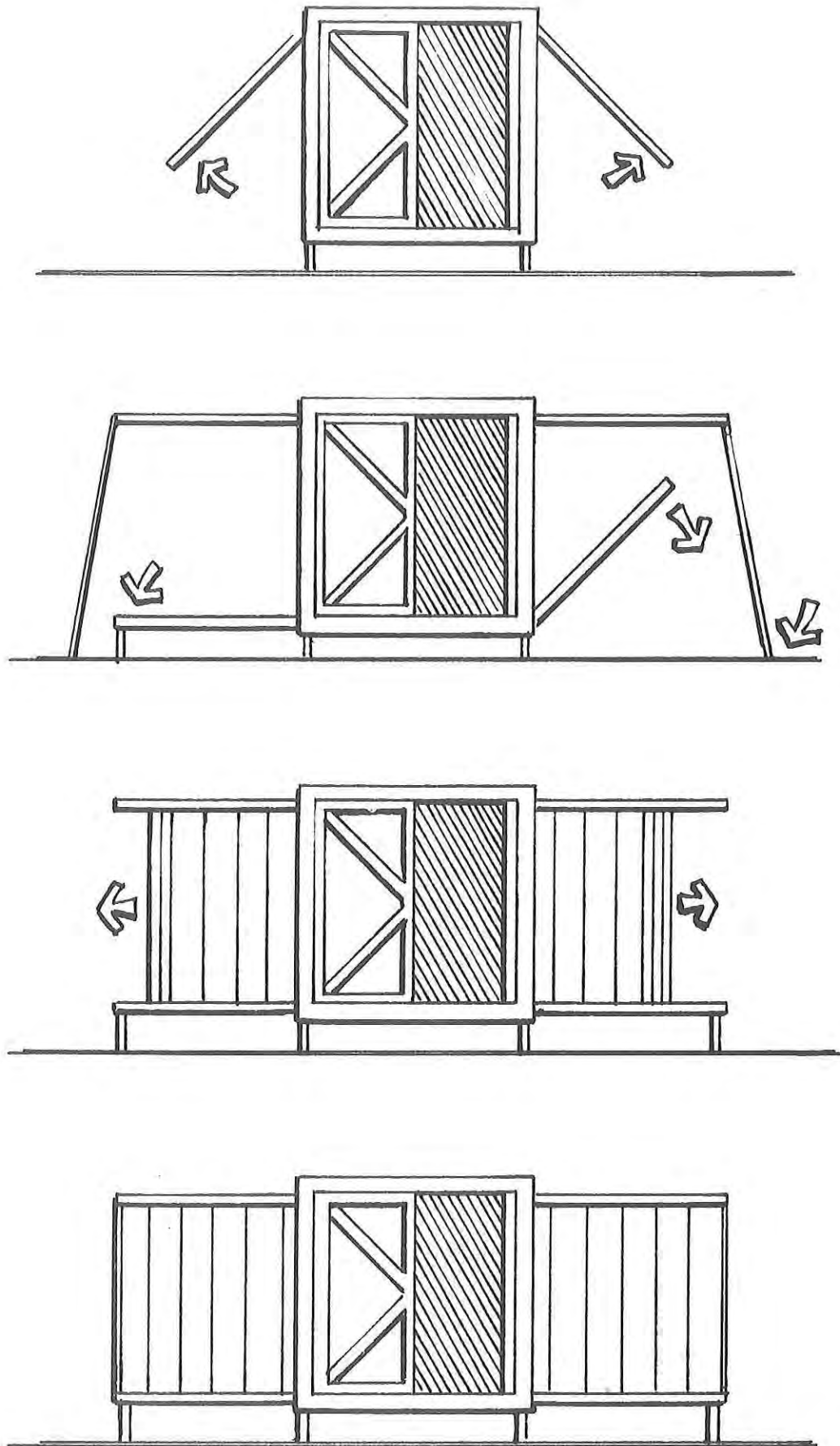

Figure 84. Expansion Procedure

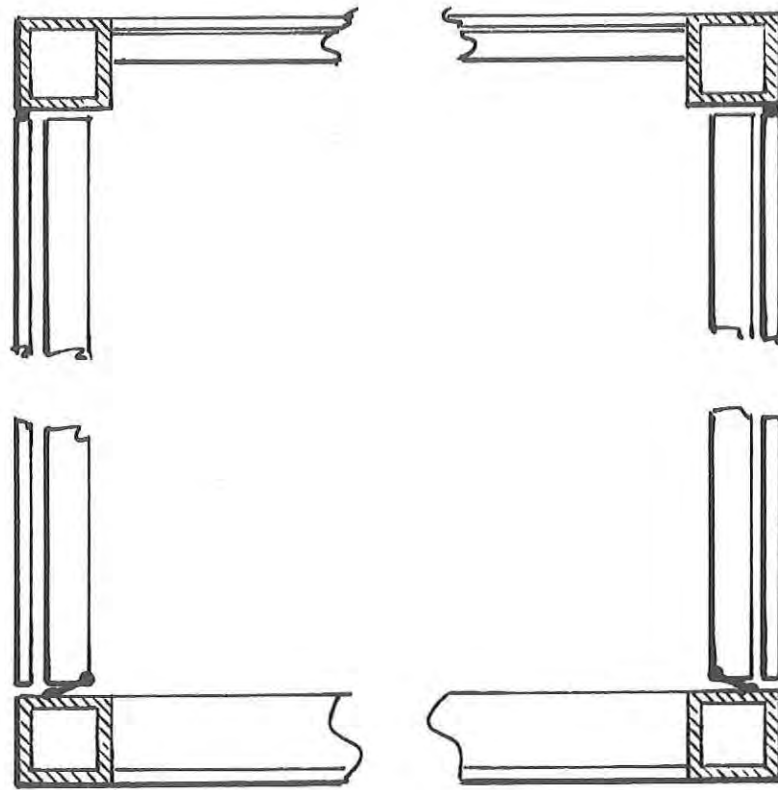

Figure 85. Longitudinal Section, Container Mode

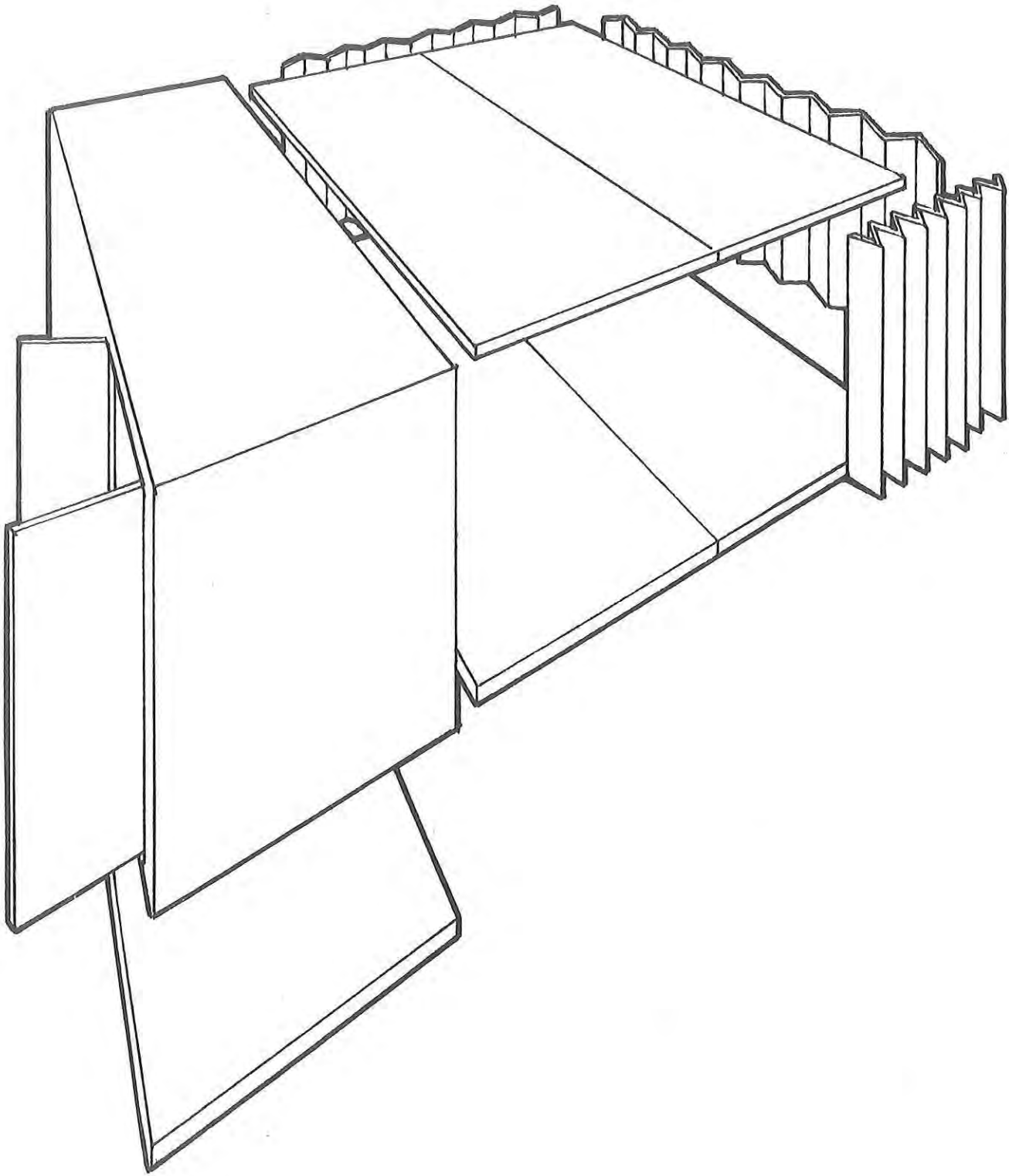

Figure 86. Configuration 0

2. Expansion Procedure (Figures 87 & 88.)
  - a. Shelter core is leveled on jack standards.
  - b. Side wall assembly is raised to become shelter roof, supported by braces
  - c. Floor panels swing into place and are leveled on jack standards
  - d. Expanding folded walls are drawn into position, sealed and secured by locking devices.
3. Utilization of Interior

Access:

- Container - side access through double cargo doors
- Shelter - side access through double cargo doors

Attachments:

- Container - fixed: floor, ends, sides, roof
- temporary: floor, ends, sides, roof
- Shelter - fixed: floor, ends, side, roof
- temporary: floor, ends, side, roof, top of nearest expanding floor panel
- Mechanical : Ends and access side of shelter core are likely places for mechanical outlets.

4. Joinery

Airtight, watertight shelter can be produced. Problems may occur weathersealing roof panels and wall-to-floor and roof; also, seams in expanding wall panels.

Configuration P - This configuration uses either filament wound cores which have integral frames, or injection molded modules with external frames together with large injection molded or thermoformed expandable modules.

1. Components (Figure 89.)

- 3 Core sizes
- 3 Pallet sizes
- 3 Floor sizes

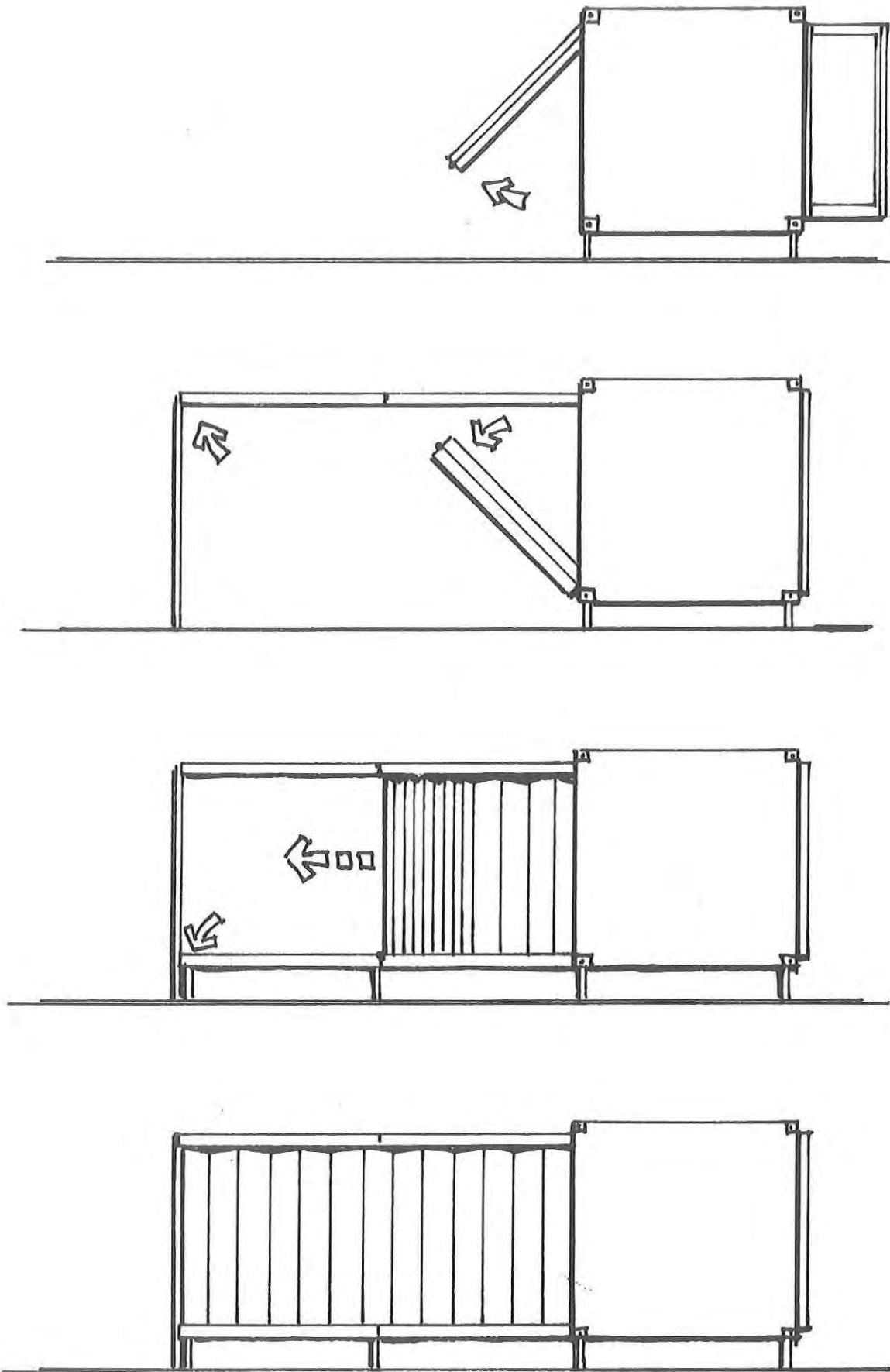

Figure 87. Expansion Procedure

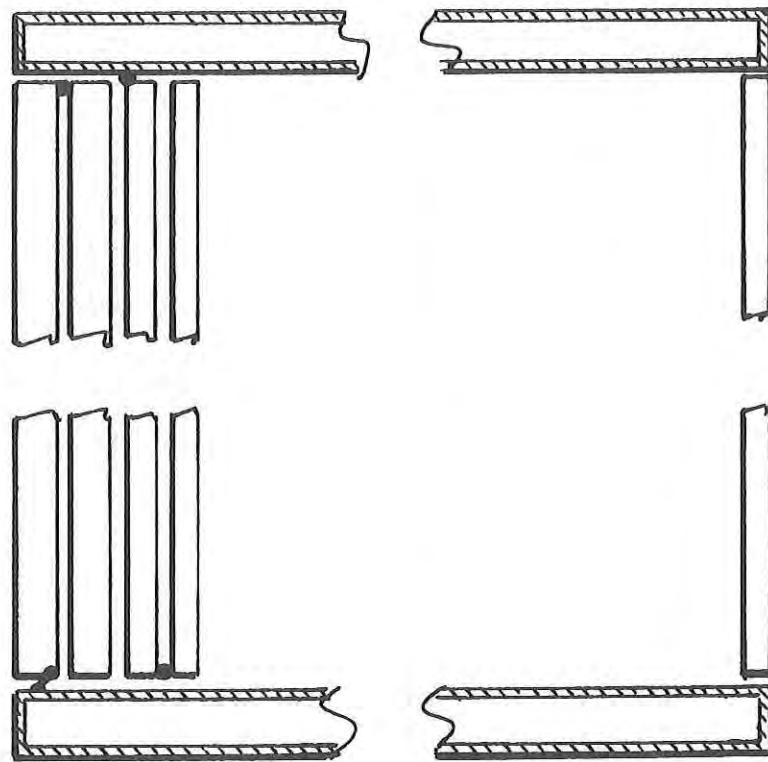

Figure 88. Longitudinal Section, Container Mode

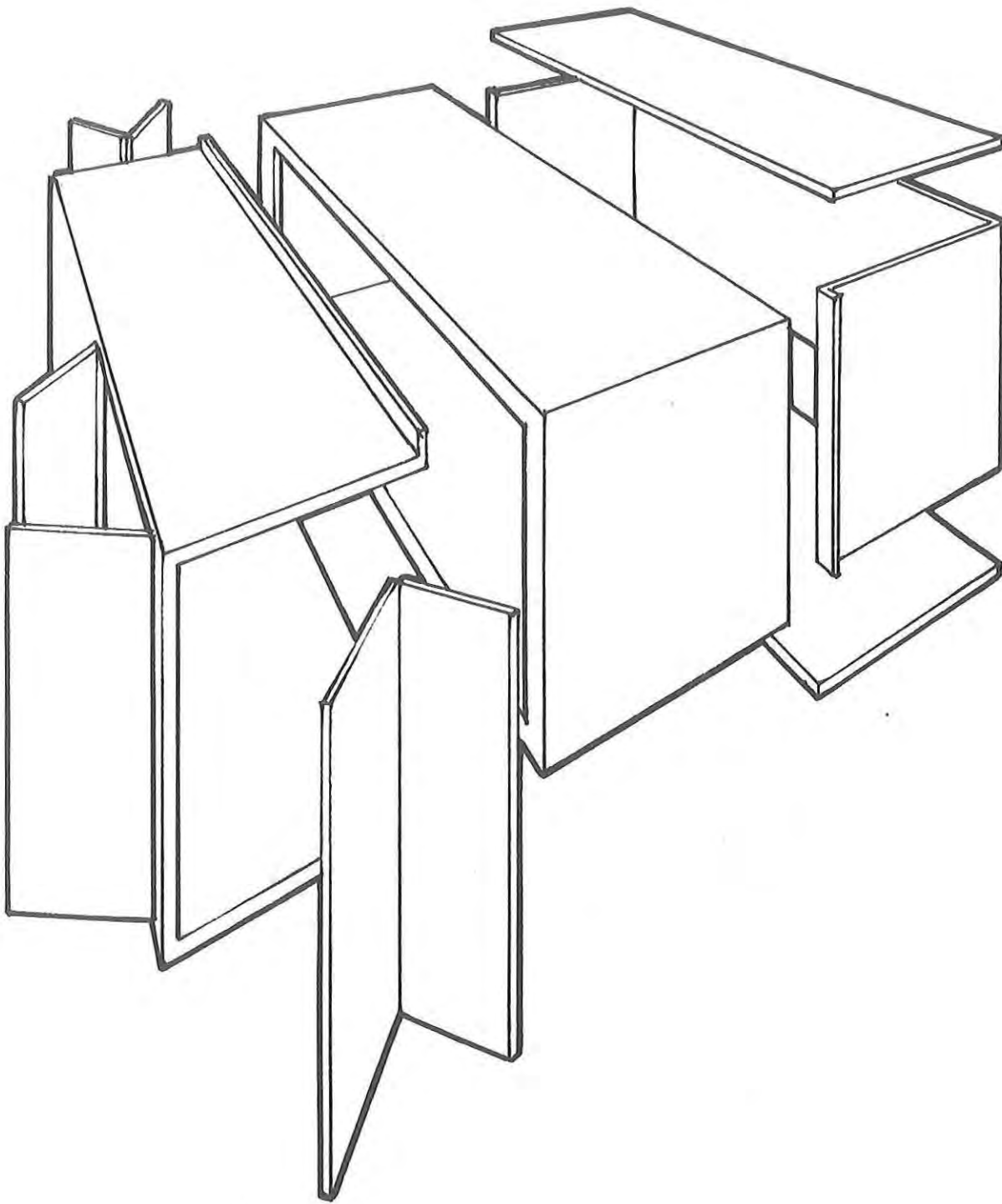

Figure 89. Configuration P

- 3 Roof sizes
  - 1 Folding end wall
  - 1 Stock Left
  - 1 Stock Right
  - 1 Common Access Door
  - 1 Expansion Track
  - 1 Universal Leveling Device
- 
- 18 Major Basic Components

2. Expansion Procedure (Figures 90 & 91.)

- a. Shelter core is leveled on jack standards
- b. Side expansion tracks are positioned and leveled
- c. Expanding side modules are drawn out
- d. On access side, folding end walls are hinged into place, sealed, and secured by locking devices
- e. On opposite side, roof and floor panels are hinged into position and secured by locking devices.

3. Utilization of Interior

Access:

- Container - side access through double cargo doors.
- Shelter - side access through double cargo doors. Additional access through folding end walls on personnel door located in other walls.

Attachments:

- Container - fixed: floor, sides, ends, roof
- temporary: floor, sides, ends, roof
- Shelter - fixed: none
- temporary: access side floor, side wall.
- Mechanical : access side wall presents best mechanical outlet attachment side.

4. Joinery

Airtight, watertight shelter is possible. Problem areas are weathersealing swing-up roof panel and with mechanics of expansion.

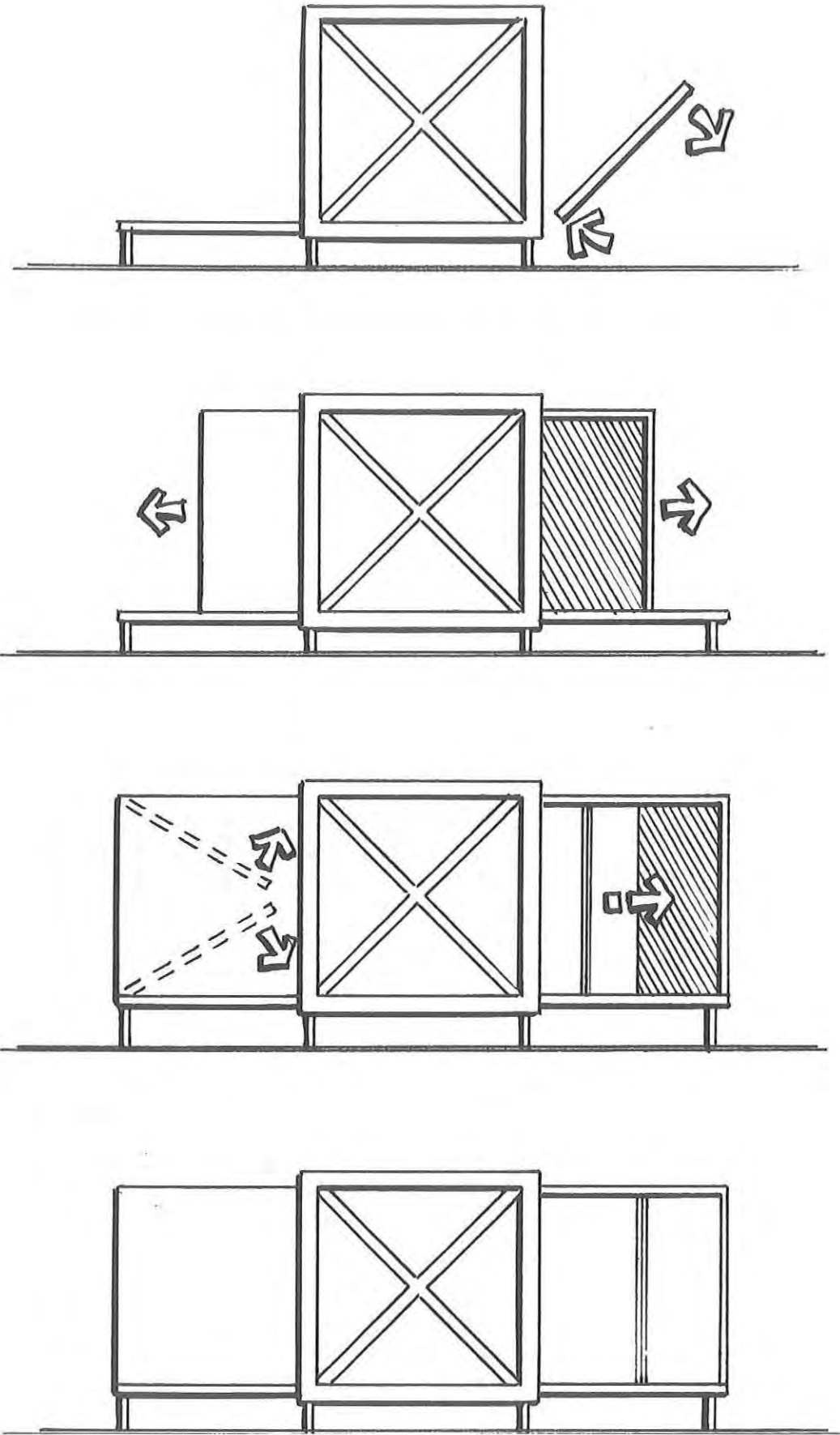

Figure 90. Expansion Procedure

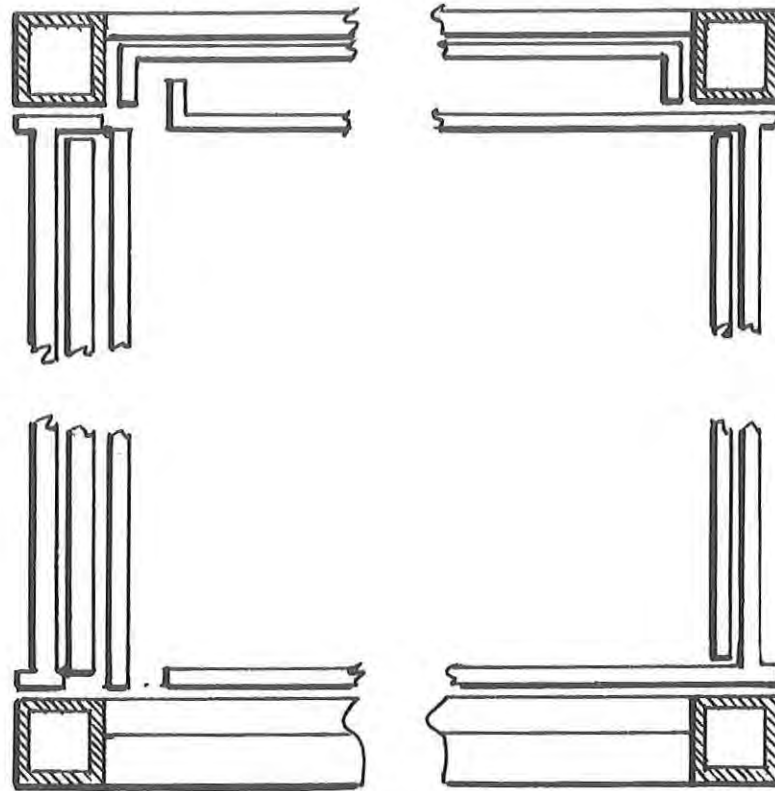

Figure 91. Longitudinal Section, Container Mode

Configuration Q - This configuration uses either filament-wound cores with integral frames or injection molded or thermoformed core modules with external frames together with large injection molded or thermoformed expanding modules

1. Components (Figure 92.)

- 3 Core sizes
- 3 Pallet sizes
- 2 Floor panel sizes
- 2 Expanding modules (Left & Right)
- 2 Expansion tracks
- 2 Leveling devices
- 1 Common access door
- 1 3-1/3" Container side panel

16 Major Basic Components

2. Expansion Procedure (Figures 93 & 94.)

- a. Shelter core is leveled on jack standards
- b. Suspension track and brace are installed.
- c. Expanding modules are drawn out into position and secured

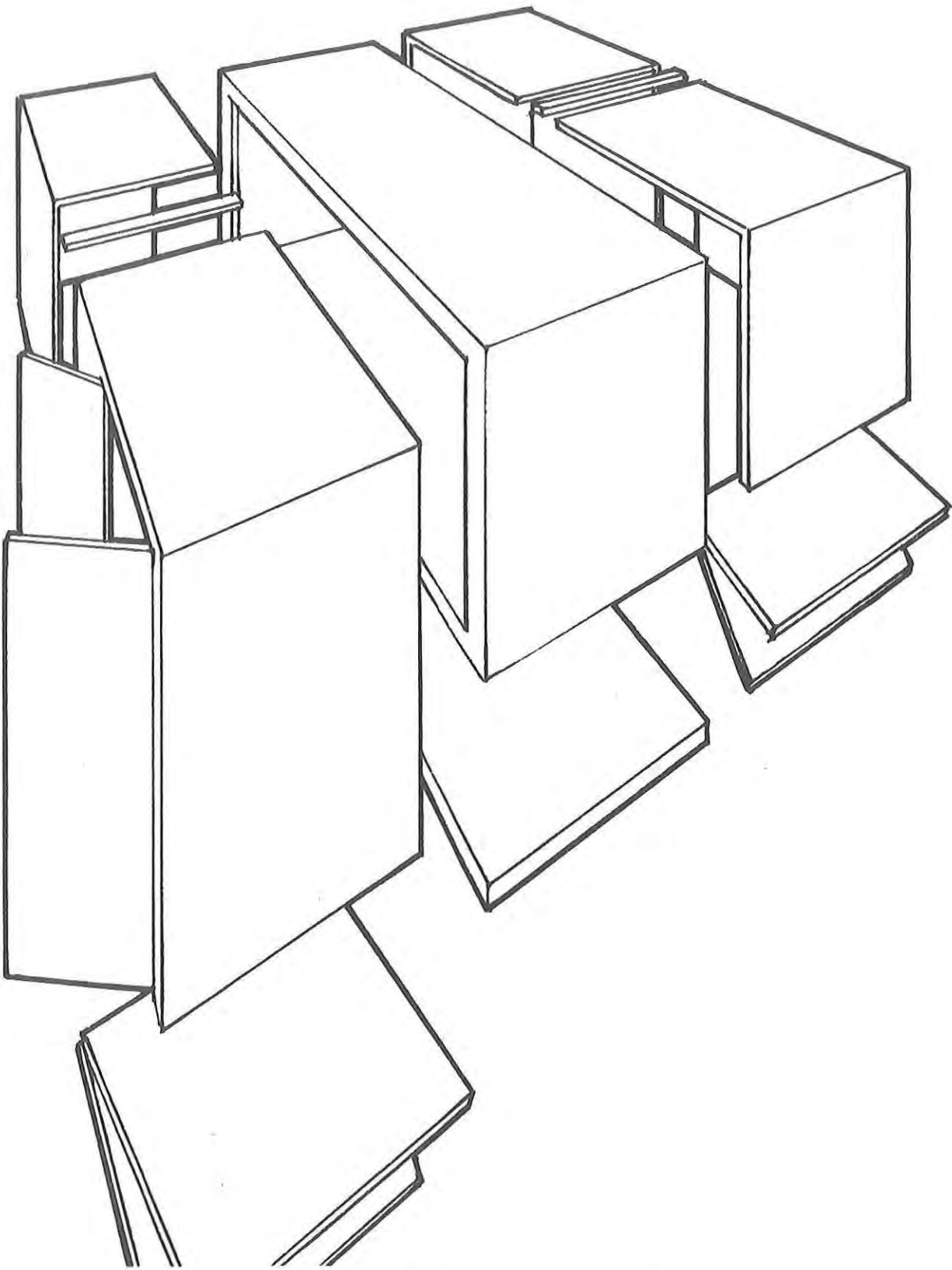

Figure 92. Configuration Q

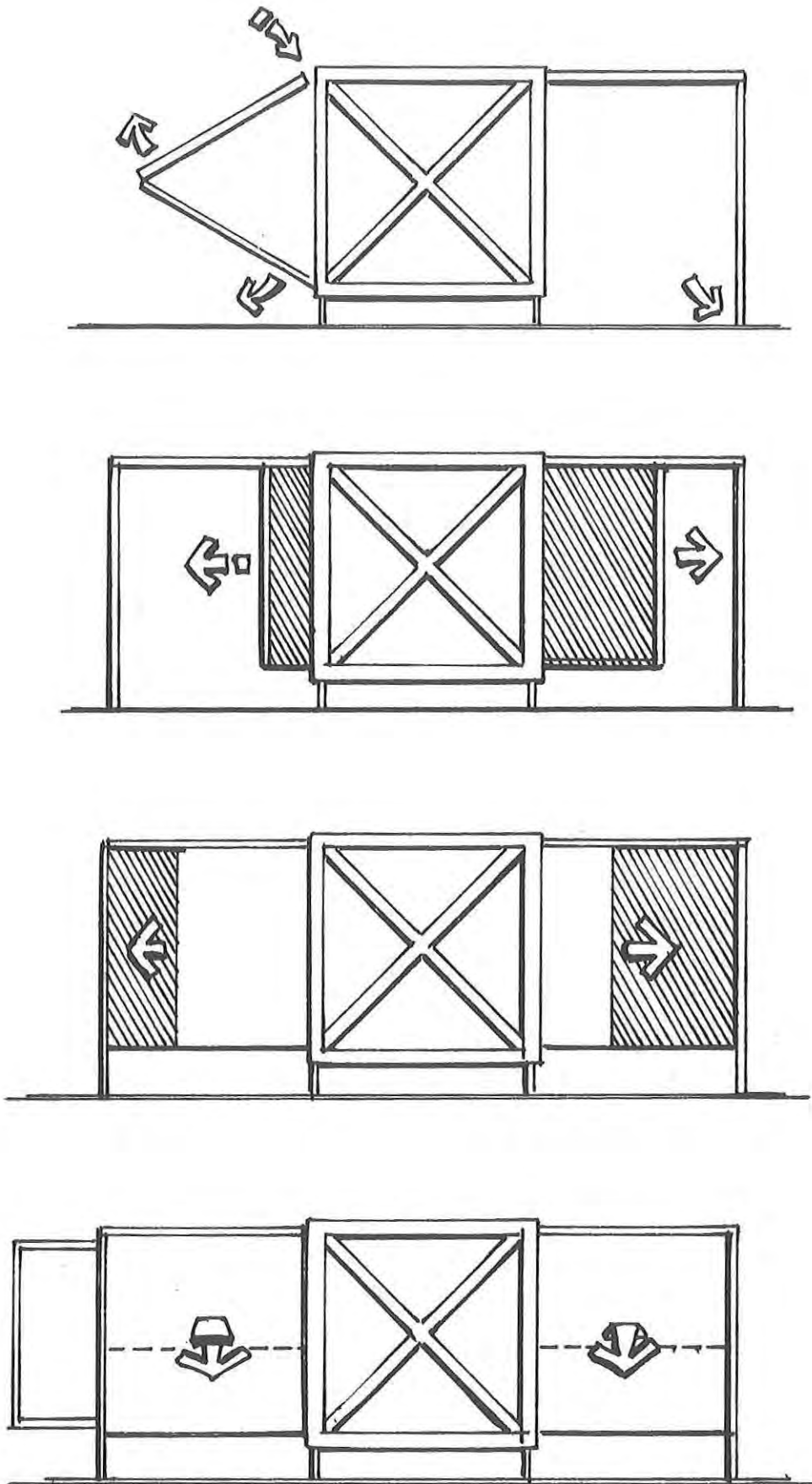

Figure 93. Expansion Procedure

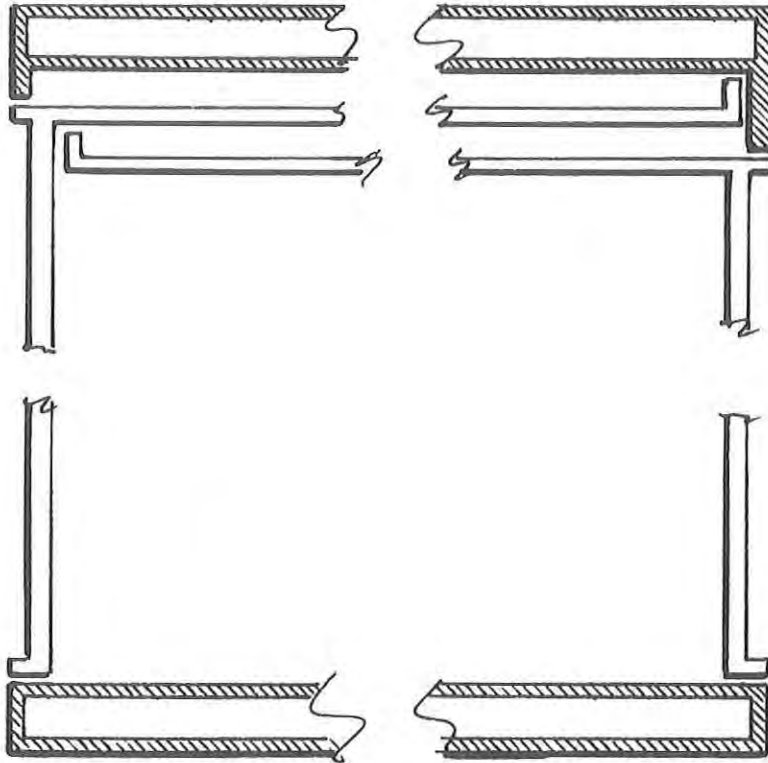

Figure 94. Longitudinal Section Container Mode

- d. Floors unfold from end walls and are secured
- e. Jack standards are deployed, support shelter.

### 3. Utilization of Interior

#### Access:

- Container - side access through double doors
- Shelter - side access through double doors

#### Attachments:

- Container - fixed: floor, sides, ends, roof
- temporary: floor, sides, ends, roof
- Shelter - fixed: floor
- temporary: floor, expanding floor tops,  
side walls

- Mechanical : Core end walls may be used  
for mechanical outlets in  
shelter modes.

#### 4. Joinery

Airtight, watertight shelter is possible. Problem area is weathersealing and mechanics involved with suspension track.

## VII. EVALUATION

The purpose of a complete overall evaluation of the numerous alternatives presented in this report was to determine those elements which by themselves offered the best performance and to indicate those combinations of elements which had the greatest promise for combined performance in a final design configuration.

Evaluation of the alternatives suggested for the Multi-Modal Shelter System was undertaken in the following manner:

1. Four areas were described, namely, design configurations, structural frames, wall materials, and manufacturing processes.
2. Criteria for each of the four evaluation areas were established by reviewing MMSS contract requirements and applying them to their respective areas.
3. Since some criteria were obviously more important considerations in MMSS design than others, relative values on a scale 1-10 were assigned to each of the criteria.
4. Alternatives to be evaluated were listed and graded on a scale of 1-10 for each of the criteria.
5. Composite scores for each of the alternatives were arrived at by multiplying the criteria value and the alternative grade for each criteria and totaling the results for each alternative.
6. Composite scores were then compared in a hierarchical listing of alternatives for each area.

The following are the results of the evaluations of alternatives in each area (Table XXIV.)

CRITERIA	VALUE	THERMOFORMED CONFIGURATIONS															
		1A	1B	1C	1D	1E	1F	1G	1H	1I	1J	1K	1L	1M	1O	1P	1Q
1. Standardized Construction	10.0	8	3	6	4	8	6	8	6	7	5	8	8	7	6	5	8
		80	30	60	40	80	60	80	60	70	50	80	80	70	60	50	80
2. 3:1 Expandability	9.0	10	9	9	8	8	7	10	9	10	9	4	4	4	9	5	5
		90	81	81	72	72	63	90	81	90	81	36	36	36	81	45	45
3. Minimal Cost	5.0	8	6	6	6	7	6	5	8	7	6	6	6	7	6	5	7
		40	30	30	30	35	30	25	40	35	30	30	30	35	30	25	35
4. Component Replacement	7.0	9	6	5	5	4	6	8	8	7	6	8	8	7	7	6	5
		63	42	35	35	28	42	56	56	49	42	56	56	49	49	42	35
5. Expandability Procedure	7.5	9	3	3	2	2	2	1	7	9	7	8	6	7	7	3	4
		67.5	22.5	22.5	15.	15.	15.	7.5	52.5	67.5	52.5	60.0	45.0	52.5	52.5	22.5	30.0
6. U-Factor	6.0	9	7	6	5	6	5	5	5	7	6	5	3	4	4	6	7
		54	42	36	30	36	30	30	30	42	36	30	18	24	24	36	42
7. Interior Space (Volume)	5.0	6	5	6	4	6	6	7	6	8	5	6	5	5	8	5	4
		30	25	30	20	30	30	35	30	40	25	30	25	25	40	25	20
8. Utilization of Interior	7.5	8	5	7	1	1	7	8	8	9	6	7	5	7	8	1	6
		60.	37.5	52.5	7.5	7.5	52.5	60.	60.	67.5	45.	52.5	37.5	52.5	60.	7.5	45.
9. Equipment Attachment Details	2.5	6	4	5	3	1	9	5	8	8	6	5	5	7	8	1	6
		15.	10.	12.5	7.5	2.5	22.5	12.5	20.	20.	15.	12.5	12.5	17.5	20.	2.5	15.
10. Door Configurations	2.5	8	8	4	2	3	7	8	8	9	7	8	7	4	8	8	6
		20.	20.	10.	5.	7.5	17.5	20.	20.	22.5	17.5	20.	17.5	10.	20.	20.	15.
11. Container Mode Access	7.5	9	9	4	4	3	4	2	9	10	7	8	3	5	4	3	4
		67.5	67.5	30.	30.	22.5	30.	15.	67.5	75.	52.5	60.	22.5	37.5	30.	22.5	30.
12. Shelter Mode Access	7.5	9	9	6	5	4	6	2	9	10	9	9	4	7	4	3	5
		67.5	67.5	45.0	37.5	30.	45.0	15.	67.5	75.	67.5	67.5	30.	52.5	30.	22.5	37.5
13. Floor Construction	3.0	6	8	4	4	4	4	3	8	8	8	8	3	5	7	7	5
		18	24	12	12	12	12	9	24	24	24	24	9	15	21	21	15
14. Leveling Device/Shelter Interface	2.0	6	5	5	4	4	4	4	6	9	8	8	5	6	5	7	4
		12	10	10	8	8	8	8	12	18	16	16	10	12	10	14	8
15. Leveling System	2.5	8	5	5	4	4	4	4	6	8	8	8	6	6	5	5	4
		20	12.5	12.5	10	10.	10.	10.	15.	20	20	20	15.	15.	12.5	12.5	10.
16. Panel/Panel Attachment	1.5	4	4	6	6	6	6	4	5	8	5	7	6	6	6	7	6
		6.	6.	9.	9.	9.	9.	6.	7.5	12.	7.5	10.5	9.	9.	9.	10.5	9.
17. Panel/Frame Attachment	1.5	4	4	6	6	5	1	4	5	7	5	6	5	6	7	6	5
		6.	6.	9.	9.	7.5	1.5	6.	7.5	10.5	7.5	9.	7.5	9.	10.5	9.	7.5
18. Minimal Loose Parts	4.0	10	10	10	7	7	5	1	7	8	6	9	8	5	5	8	5
		40	40	40	28	28	20	4	28	32	24	36	32	20	20	32	20
19. Mobilizer Attachment	1.5	6	6	8	6	7	6	7	7	7	7	7	7	7	7	7	7
		9.	9.	12.	9.	10.5	9.	10.5	10.5	10.5	10.5	10.5	10.5	10.5	10.5	10.5	10.5
20. Tow Ring & Attachment	1.5	6	6	8	6	7	6	7	7	7	7	7	7	7	7	7	7
		9.	9.	12.	9.	10.5	9.	10.5	10.5	10.5	10.5	10.5	10.5	10.5	10.5	10.5	10.5
21. Forklift Tineways	2.5	7	8	8	6	7	6	7	7	7	7	7	7	7	7	7	7
		17.5	20.	20.	15.	17.5	15.	17.5	17.5	17.5	17.5	17.5	17.5	17.5	17.5	17.5	17.5
22. Watertightness	5.0	6	8	8	4	9	4	2	6	8	5	5	5	5	5	6	7
		30	40	40	20	45	20	10	30	40	25	25	25	25	25	30	35
23. EMI Shielding	1.0	4	5	7	6	6	6	3	7	8	4	5	5	5	5	5	6
		4	5	7	6	6	6	3	7	8	4	5	5	5	5	5	6
24. Feasibility	10.0	8	7	8	6	8	5	2	7	7	6	5	6	7	7	4	6
		80	70	80	60	80	50	20	70	70	60	50	60	70	70	40	60
25. ISO Size Standards	10.0	10	8	8	6	6	4	10	9	8	8	7	6	7	7	5	3
		100	80	80	60	60	40	100	90	80	80	70	60	70	70	50	30
COMPOSITE SCORE		1006	806.	788.	584.	670.	606.	660.	904.	1004	820.	833.	681.	750.	788.	583.	668.
PROCESS AVERAGE SCORE		759.6															

TABLE XXIV. DESIGN CONFIGURATION EVALUATION

	INJECTION MOLDED CONFIGURATIONS															ROTOMOLDED CONFIGURATIONS							
	2A	2B	2C	2D	2E	2F	2G	2H	2I	2J	2K	2L	2M	2O	2P	2Q	3A	3E	3I	3J	3K	3N	3O
1.	8	3	6	4	6	6	7	5	7	5	8	9	7	6	5	8	4	4	7	5	5	9	6
	80	30	60	40	60	60	70	50	70	50	80	90	70	60	50	80	40	40	70	50	50	90	60
2.	10	9	9	8	8	7	10	9	10	9	4	4	4	9	5	5	10	8	10	9	4	10	9
	90.	81	81	72	72	63	90	81	90	81	36	36	36	81	45	45	90	72	90	81	36	90	81
3.	6	4	3	4	6	5	4	5	5	4	5	5	6	5	6	6	5	5	6	5	5	6	6
	30	20	15	20	30	25	20	25	25	20	25	25	30	25	30	30	25	25	30	25	25	30	30
4.	9	6	5	5	4	6	8	8	7	6	8	8	7	7	6	5	7	4	7	6	7	7	7
	63	42	35	35	28	42	56	56	49	42	56	56	49	49	42	35	49	28	49	42	49	49	49
5.	9	3	3	2	2	2	1	7	9	7	8	6	7	7	3	4	9	2	9	7	8	8	7
	67.5	22.5	22.5	15.	15.	15.	7.5	52.5	67.5	52.5	60.	45.	52.5	52.5	22.5	30.	67.5	15.	67.5	52.5	60.	60.	52.5
6.	7	7	6	5	6	5	5	6	8	6	6	4	4	5	6	7	7	4	6	5	5	5	4
	42	42	36	30	36	30	30	36	48	36	36	24	24	30	36	42	42	24	36	30	30	30	24
7.	8	5	6	4	6	6	7	6	8	5	6	5	5	8	5	4	8	6	8	5	6	6	8
	40	25	30	20	30	30	35	30	40	25	30	25	25	40	25	20	40	30	40	25	30	30	40
8.	8	5	7	1	1	7	8	8	9	6	7	5	7	8	1	6	9	1	9	6	7	7	8
	60.	37.5	52.5	7.5	7.5	52.5	60.	60.	67.5	45.	52.5	37.5	52.5	60.	7.5	45.	67.5	7.5	67.5	45.	52.5	52.5	60.
9.	5	4	5	3	1	9	5	8	8	6	6	6	7	8	1	6	6	1	7	6	5	6	8
	12.5	10.	12.5	7.5	2.5	22.5	12.5	20.	20.	15.	15.	15.	17.5	20.	2.5	15.	15.	2.5	17.5	15.	12.5	15.	20.
10.	10	8	4	2	3	7	8	8	9	7	8	7	4	8	8	6	7	3	9	6	6	7	8
	25.	20.	10.	5.	7.5	17.5	20.	20.	22.5	17.5	20.	17.5	10.	20.	20.	15.	17.5	7.5	22.5	15.	15.	17.5	20.
11.	9	9	4	4	3	4	2	9	10	7	8	3	5	4	3	4	7	3	10	7	8	7	4
	67.5	67.5	30.	30.	22.5	30.	15.	67.5	75.	52.5	60.	22.5	37.5	30.	22.5	30.	52.5	22.5	75.	52.5	60.	52.5	30.
12.	9	9	6	5	4	6	2	9	10	9	9	4	7	4	3	5	7	4	10	9	9	8	4
	67.5	67.5	45.	37.5	30.	45.	15.	67.5	75.	67.5	67.5	30.	52.5	30.	22.5	37.5	52.5	30.	75.	67.5	67.5	60.	30.
13.	6	8	4	4	4	4	3	8	8	8	8	3	5	7	7	5	6	4	8	8	8	8	7
	18	24	12	12	12	12	9	24	24	24	24	9	15	21	21	15	18	12	24	24	24	24	21
14.	6	5	5	4	4	4	4	6	9	8	8	5	6	5	7	4	6	4	9	8	8	8	5
	12	10	10	8	8	8	8	12	18	16	16	10	12	10	14	8	12	8	18	16	16	16	10
15.	8	5	5	4	4	4	4	6	8	8	8	6	6	8	5	4	8	4	8	8	8	8	5
	20.	12.5	12.5	10.	10.	10.	10.	15.	20.	20.	20.	15.	15.	20.	12.5	10.	20.	10.	20.	20.	20.	20.	12.5
16.	4	4	6	6	6	6	4	5	8	5	7	6	6	6	7	6	5	6	8	5	7	7	6
	6.	6.	9.	9.	9.	9.	6.	7.5	12.	7.5	10.5	9.	9.	9.	10.5	9.	7.5	9.	12.	7.5	10.5	10.5	9.
17.	4	4	6	6	5	1	4	5	7	5	6	5	6	7	6	5	5	5	7	5	6	7	7
	6.	6.	9.	9.	7.5	1.5	6.	7.5	10.5	7.5	9.	7.5	9.	10.5	9.	7.5	7.5	7.5	10.5	7.5	9.	10.5	10.5
18.	10	10	10	7	7	5	1	7	8	6	9	8	5	5	8	5	10	7	8	6	9	6	5
	40	40	40	28	28	20	4	28	32	24	36	32	20	20	32	20	40	28	32	24	36	24	20
19.	6	6	8	6	7	6	7	7	7	7	7	7	7	7	7	7	6	7	7	7	7	7	7
	9.	9.	12.	9.	10.5	9.	10.5	10.5	10.5	10.5	10.5	10.5	10.5	10.5	10.5	10.5	9.	10.5	10.5	10.5	10.5	10.5	10.5
20.	6	6	8	6	7	6	7	7	7	7	7	7	7	7	7	7	6	7	7	7	7	7	7
	9.	9.	12.	9.	10.5	9.	10.5	10.5	10.5	10.5	10.5	10.5	10.5	10.5	10.5	10.5	9.	10.5	10.5	10.5	10.5	10.5	10.5
21.	8	8	8	6	7	6	7	7	7	7	7	7	7	7	7	7	6	7	7	7	7	7	7
	20.	20.	20.	15.	17.5	15.	17.5	17.5	17.5	17.5	17.5	17.5	17.5	17.5	17.5	17.5	15.	17.5	17.5	17.5	17.5	17.5	17.5
22.	6	8	8	4	9	4	2	6	8	5	5	5	5	5	6	7	6	9	8	5	5	6	5
	30	40	40	20	45	20	10	30	40	25	25	25	25	25	30	35	30	45	40	25	25	30	25
23.	6	6	7	6	6	6	3	7	6	4	5	6	5	5	5	6	6	6	8	4	6	6	5
	6	6	7	6	6	6	3	7	6	4	5	6	5	5	5	6	6	6	8	4	6	6	5
24.	8	6	7	5	7	4	2	6	6	4	5	5	6	5	4	5	5	3	5	3	3	4	3
	80	60	70	50	70	40	20	60	60	40	50	50	60	50	40	50	50	30	50	30	30	40	30
25.	10	8	8	6	6	4	10	9	8	8	7	6	7	7	5	3	10	6	8	8	7	9	7
	100	80	80	60	60	40	100	90	80	80	70	60	70	70	50	30	100	60	80	80	70	90	70
	1163	787.	763.	564.	632.	632.	639.	883.	990.	780.	842.	685.	735.	776.	610.	653.	882.	580.	973.	777.	772.	886.	748.
	758.6															802.7							

TABLE XXIV.

TABLE XXIV.

CRITERIA	VALUE	FILAMENT-WOUND CONFIGURATIONS							SANDWICH PANEL CONFIGURATIONS							
		4C	4E	4L	4M	4O	4P	4Q	5A	5G	5H	5I	5J	5K	5M	5O
1. Standardized Construction	10.0	4	4	8	6	6	4	8	8	9	7	9	7	9	7	7
		40	40	80	60	60	40	80	80	90	70	90	70	90	70	70
2. 3:1 Expandability	9.0	8	8	4	4	9	5	5	10	10	9	10	9	4	4	9
		72	72	36	36	81	45	45	90	90	81	90	81	36	36	81
3. Minimal Cost	5.0	3	4	6	7	6	5	5	8	7	7	8	7	7	8	8
		15	20	30	35	30	25	25	40	35	35	40	35	35	40	40
4. Component Replacement	7.0	2	4	7	6	7	6	5	9	10	8	8	8	8	7	8
		14	28	49	42	49	42	35	63	70	56	56	56	56	49	56
5. Expandability Procedure	7.5	3	2	6	7	7	3	4	9	1	7	9	7	8	7	7
		22.5	15.	45.	52.5	52.5	22.5	30.	67.5	7.5	52.5	67.5	52.5	60.	52.5	52.5
6. U-Factor	6.0	8	6	5	4	5	6	7	9	5	6	8	6	6	4	5
		48	36	30	24	30	36	42	54	30	36	48	36	36	24	30
7. Interior Space (Volume)	5.0	6	6	5	5	8	5	4	8	7	6	8	5	6	5	8
		30	30	25	25	40	25	20	40	35	30	40	25	30	25	40
8. Utilization of Interior	7.5	7	1	5	7	8	1	6	9	8	8	9	6	7	7	8
		52.5	7.5	37.5	52.5	60.	7.5	45.	67.5	60.	60.	67.5	45.	52.5	52.5	60.
9. Equipment Attachment Details	2.5	5	1	6	7	8	1	6	8	5	8	8	7	7	7	8
		12.5	2.5	15.	17.5	20.	2.5	15.	20.	12.5	20.	20.	17.5	17.5	17.5	20.
10. Door Configurations	2.5	4	3	7	4	8	8	6	10	8	8	9	8	8	4	8
		10	7.5	17.5	10.	20.	20.	15.	25.	20.	20.	22.5	20.	20.	10.	20.
11. Container Mode Access	7.5	4	3	3	5	4	3	4	9	2	9	10	7	8	5	4
		30	22.5	22.5	37.5	30.	22.5	30.	67.5	15.	67.5	75.	52.5	60.	37.5	30.
12. Shelter Mode Access	7.5	6	4	4	7	4	3	5	9	2	9	10	9	9	7	4
		45.	30.	30.	52.5	30.	22.5	37.5	67.5	15.	67.5	75.	67.5	67.5	52.5	30.
13. Floor Construction	3.0	4	4	3	5	7	7	5	8	3	8	8	8	8	5	7
		12	12	9	15	21	21	15	24	9	24	24	24	24	15	21
14. Leveling Device/Shelter Interface	2.0	5	4	5	6	5	7	4	8	4	6	9	8	8	6	5
		10	8	10	12	10	14	8	16	8	12	18	16	16	12	10
15. Leveling System	2.5	5	4	6	6	5	5	4	8	4	6	8	8	8	6	5
		12.5	10.	15.	15.	12.5	12.5	10.	20.	10.	15.	20.	20.	20.	15.	12.5
16. Panel/Panel Attachment	1.5	8	6	6	6	6	7	6	6	4	5	8	6	7	6	6
		12.	9.	9.	9.	9.	10.5	9.	9.	6.	7.5	12.	9.	10.5	9.	9.
17. Panel/Frame Attachment	1.5	7	5	5	6	7	6	5	6	4	5	7	6	6	6	7
		10.5	7.5	7.5	9.	10.5	9.	7.5	9.	6.	7.5	10.5	9.	9.	9.	10.5
18. Minimal Loose Parts	4.0	10	7	8	5	5	8	5	10	1	7	8	6	9	5	5
		40	28	32	20	20	32	20	40	4	28	32	24	36	20	20
19. Mobilizer Attachment	1.5	8	7	7	7	7	7	7	8	7	7	7	7	7	7	?
		12.	10.5	10.5	10.5	10.5	10.5	10.5	12.	10.5	10.5	10.5	10.5	10.5	10.5	10.5
20. Tow Ring & Attachment	1.5	8	7	7	7	7	7	7	8	7	7	7	7	7	7	?
		12.	10.5	10.5	10.5	10.5	10.5	10.5	12.	10.5	10.5	10.5	10.5	10.5	10.5	10.5
21. Forklift Tineways	2.5	8	7	7	7	7	7	7	8	7	7	7	7	7	7	7
		20.	17.5	17.5	17.5	17.5	17.5	17.5	20.	17.5	17.5	17.5	17.5	17.5	17.5	17.5
22. Watertightness	5.0	9	9	5	5	5	6	7	6	2	6	8	5	5	5	5
		45	45	25	25	25	30	35	30	10	30	40	25	25	25	25
23. EMI Shielding	1.0	6	6	5	5	5	5	6	8	3	7	8	4	5	5	5
		6	6	5	5	5	5	6	8	3	7	8	4	5	5	5
24. Feasibility	10.0	5	5	5	5	6	3	5	10	3	7	9	5	6	6	7
		50	50	50	50	60	30	50	100	30	70	90	50	60	60	70
25. ISO Size Standards	10.0	7	6	6	7	7	5	3	10	10	9	8	8	7	7	9
		70	60	60	70	70	50	30	100	100	90	80	80	70	70	90
COMPOSITE SCORE		704.	585.	678.	690.	784.	563.	648.	1082	704.	925.	1054	827.	874.	745.	841.
PROCESS AVERAGE SCORE		663.6							881.7							

Design Configuration Designation Key:

- Numbers refer to manufacturing processes:

- 1 = Thermoforming
- 2 = Injection Molding
- 3 = Rotomolding
- 4 = Filament-Winding
- 5 = Sandwich Panels

- Letters refer to configurations described in Section VI.B.

The following list groups the design configurations, giving scores for their respective manufacturing processes and average scores for the design configurations.

1A	1006.0	1G	660.5	1M	750.0
2A	1163.0	2G	639.5	2M	735.0
3A	882.5	5G	704.5	4M	690.0
5A	1082.0			5M	745.0
Avg. A	1033.3	Avg. G	668.1	Avg. M	730.00

1B	806.5	1H	904.0	3N	886.0
2B	787.5	2H	883.0	Avg. N	886.0
Avg. B	797.0	5H	925.0		
		Avg. H	904.0		

1C	788.0	1I	1004.5	1O	788.0
2C	763.0	2I	990.5	2O	776.5
4C	696.0	3I	973.0	3O	748.0
Avg. C	749.0	5I	1054.5	4O	784.0
		Avg. I	1005.6	5O	841.0
				Avg. O	787.5

1D	584.5	1J	820.5	1P	583.0
2D	564.5	2J	780.0	2P	610.5
Avg. D	574.5	3J	777.0	4P	563.0
		5J	827.5	Avg. P	585.5
		Avg. J	801.3		

1E	670.0	1K	833.5	1Q	668.5
2E	632.5	2K	842.0	2Q	653.5
3E	580.5	3K	772.5	4Q	648.5
4E	585.0	5K	874.5	Avg. Q	656.8
Avg. E	617.0	Avg. K	830.6		

1F	606.5	1L	681.0
2F	632.0	2L	685.5
Avg. F	619.2	4L	678.5
		Avg. L	681.6

From the above average scores, a ranking of the design configurations was established.

<u>Rank</u>	<u>Design Config.</u>	<u>Avg. Score</u>	<u>Rank</u>	<u>Design Config.</u>	<u>Avg. Score</u>
1.	A	1033.3	10.	M	730.0
2.	I	1005.6	11.	L	681.6
3.	H	904.0	12.	G	668.1
4.	N	886.0	13.	Q	656.8
5.	K	830.6	14.	F	619.2
6.	J	801.3	15.	E	617.0
7.	B	797.0	16.	P	585.5
8.	O	787.5	17.	D	574.5
9.	C	749.0			

It is noted by referring to the design configuration catalog, Section III, B., that the four top-ranking design configurations were all modifications of a basic panel system with suggested production methods in all process areas except filament-winding. This tendency is reinforced by examining the manufacturing process average scores obtained from the design configuration matrix:

<u>Rank</u>	<u>Process</u>	<u>Process Avg. Score</u>
1	Sandwich Panel	881.7
2	Rotomolding	802.7
3	Thermoforming	759.6
4	Injection-Molding	758.6
5	Filament-Winding	663.6

This table indicates relative suitability of the manufacturing processes for producing an acceptable shelter based strictly on configuration criteria.

TABLE XXV. MANUFACTURING PROCESS EVALUATION

		PROCESS				
		Frame & Panel	Filament Winding	Rotomolding	Injection Molding	Thermoforming
CRITERIA	VALUE					
L. Mass Producibility	10.0	9	8	5	8	8
		90	80	50	80	80
2. Cost	5.0	8	7	6	6	7
		40	35	30	30	35
3. Door Configuration	7.5	10	5	6	9	7
		75	37.5	45.	67.5	52.5
4. Standardized Configuration	9.0	10	8	8	10	9
		90	72	72	90	81
5. Overall Feasibility	10.0	9	8	4	7	8
		90	80	40	70	80
TOTAL SCORE:		385.0	304.5	237.0	337.5	328.5

From this basic evaluation of each of the processes, a ranking was determined.

<u>Rank</u>	<u>Process</u>	<u>Total Score</u>
1	Sandwich Panel	385.5
2	Injection Molding	337.5
3	Thermoforming	328.5
4	Filament Winding	304.5
5	Rotomolding	237.0

TABLE XXVI.  
MATERIALS EVALUATION

		MATERIALS															
CRITERIA	VALUE	Steel	Aluminum	Al/Paper Honeycomb/Al	Al/Nomex Honeycomb/Al	FRP/Paper Honeycomb/FRP	FRP/Nomex Honeycomb/FRP	Al/Al Honeycomb/Al	Al/Plywood/Al	Al/Styrofoam/Al	Steel/Styrofoam/Steel	FRP/Plywood/FRP	FRP/Styrofoam/FRP	FRP	FRP/Urethane Foam/FRP - FRP Edges	FRP/Urethane Foam/FRP Steel Edges	FRP/Urethane Foam/FRP Al Edges
1. Minimal Weight	6.0	5	8	8	7	7	8	6	5	8	6	3	9	9	9	6	8
		30	48	48	42	42	48	36	30	48	36	18	54	54	54	36	48
2. 5-10 Year Field Life	8.0	5	3	7	7	7	9	8	9	8	8	8	7	4	6	7	7
		40	24	56	56	56	72	64	72	64	64	64	56	32	48	56	56
3. Cost	4.5	9	7	7	7	7	7	6	7	8	9	8	9	9	8	8	7
		40.	31.	31.	31.	31.	31.	27.	31.	36.	40.	36.	40.	40.	36.	36.	31.
4. Repair	8.0	5	5	6	6	7	7	6	6	6	6	7	7	7	7	7	7
		40	40	48	48	56	56	48	48	48	48	56	56	56	56	56	56
5. Periodic Maintenance	6.0	4	5	5	5	7	7	5	5	5	4	7	7	7	7	7	7
		24	30	30	30	42	42	30	30	30	24	42	42	42	42	42	42
6. Material U-Factor	7.5	2	1	4	4	9	9	1	5	8	9	7	10	6	10	5	5
		15.	7.	30.	30.	67.	67.	7.	37.	60.	67.	52.	75.	45.	75.	37.	37.
7. Watertightness	7.5	10	10	10	10	10	10	10	10	10	10	10	10	10	10	10	10
		75	75	75	75	75	75	75	75	75	75	75	75	75	75	75	75
8. EMI Shielding	1.0	9	9	9	9	3	3	9	9	9	9	3	3	1	3	5	5
		9	9	9	9	3	3	9	9	9	9	3	3	1	3	5	5
9. Overall Feasibility	10.0	1	1	4	4	5	9	1	2	8	6	3	9	2	9	3	5
		10	10	40	40	50	90	10	20	80	60	30	90	20	90	30	50
10. Impact Resistance	8.0	6	5	6	6	7	7	6	8	6	7	8	7	5	7	7	7
		48	40	48	48	56	56	48	64	48	56	64	56	40	56	56	56
COMPOSITE SCORE		391	384	455	449	508	540	414	466	498	489	490	527	465	525	479	486

TABLE XXVI.

M A T E R I A L S

	FRP/Urethane/FRP - FRP Reinforced Foam	FRP/Urethane/FRP - Steel Reinforced Foam	FRP/Urethane/FRP - Al Reinforced Foam	FRP/Urethane Foam/FRP	FRP/Urethane/FRP - Glass Flocking Foam	PE/Steel Core	PE/Al Core	PE/FRP Core	PE/Nylon Core	PE Foam/Steel Core	PE Foam/Al Core	PE Foam/FRP Core	PE Foam/Nylon Core	PE/Glass Microsphere Reinforced	Glass Reinforced Urethane Foam	Glass Reinforced Polycarbonate - Structural Foam	Urethane Foam/FRP Skins	HDPE Structural Foam	Polypropylene Structural Foam	Acrylic/FRP Reinforced	ABS Structural Foam	PE Foam/FRP Skins	Polycarbonate/Urethane Foam	Polypropylene Foam/FRP Skin
1.	8	6	7	9	9	6	8	9	10	6	8	9	10	10	10	10	9	9	9	8	8	9	7	9
	48	36	42	54	54	36	48	54	60	36	48	54	60	60	60	60	54	54	54	48	48	56	42	54
2.	8	8	8	7	7	8	7	7	6	9	8	8	7	6	6	7	7	5	5	6	6	8	7	6
	64	64	64	56	56	64	56	56	48	72	64	64	56	48	48	56	56	40	40	48	48	64	56	48
3.	8	8	7	9	8	10	7	9	8	10	7	9	8	10	8	9	8	9	8	8	8	9	7	7
	36.	36.	31.	40.	36.	45.	31.	40.	36.	45.	31.	40.	36.	45.	36.	40.	36.	40.	36.	36.	36.	40.	31.	31.
4.	7	7	7	7	7	5	5	6	3	5	6	6	3	3	3	3	7	3	3	7	3	7	6	7
	56	56	56	56	56	40	40	48	24	40	48	48	24	24	24	24	56	24	24	56	24	56	48	56
5.	7	7	7	7	7	4	6	6	6	4	5	6	6	5	5	5	6	5	5	6	5	6	5	6
	42	42	42	42	42	24	36	36	36	24	30	36	36	30	30	30	36	30	30	36	30	36	30	36
6.	10	9	9	10	10	5	4	7	7	6	6	8	8	7	7	7	8	8	8	6	8	10	7	10
	75.	67.	67.	75.	75.	37.	30.	52.	52.	45.	45.	60.	60.	52.	52.	52.	60.	60.	60.	45.	60.	75.	52.	75.
7.	10	10	10	10	10	10	10	10	10	10	10	10	10	10	8	9	10	9	9	10	9	10	10	10
	75	75	75	75	75	75	75	75	75	75	75	75	75	75	60.	67.	75	67.	67.	75	67.	75	75	75
8.	3	7	7	3	3	9	9	2	2	9	9	3	3	3	3	3	3	3	3	3	3	3	3	3
	3	7	7	3	3	9	9	2	2	9	9	3	3	3	3	3	3	3	3	3	3	3	3	3
9.	8	3	4	8	9	6	4	5	5	5	3	5	5	8	3	6	7	5	4	5	5	4	5	6
	80	30	40	80	90	60	40	50	50	50	30	50	50	80	30	60	70	50	40	50	50	40	50	60
10.	7	7	7	7	7	10	10	10	10	10	10	10	10	10	4	9	6	8	8	8	9	8	9	8
	56	56	56	56	56	80	80	80	80	80	80	80	80	80	32	72	48	64	64	64	72	64	72	64
	535	499	500	537	523	420	425	483	453	436	440	470	440	427	390	474	494	432	418	491	448	497	487	492

From the matrix, a ranking of the materials alternatives was determined, shown by the following list which includes score and manufacturing process for each alternative.

TABLE XXVII. MATERIAL RANKING LIST

Rank	Material	Score	Process
1	FRP/Nomex Honeycomb/FRP	540	SP
2	FRP/Urethane Foam/FRP	537	SP
3	FRP/Urethane Foam/FRP;FRP Reinforced	535	FW
4	FRP/Styrofoam/FRP	527	SP
5	FRP/Urethane Foam/FRP; FRP Edges	525	FW
6	FRP/Glass Flocked Urethane Foam/FRP	523	FW
7	FRP/Paper Honeycomb/FRP	508	SP
8	FRP/Urethane Foam/FRP; Al Reinforced	500	FW
9	FRP/Urethane Foam/FRP; Steel Reinforced	499	FW
10	Al/Styrofoam/Al	498	SP
11	PE Foam/FRP Skins	497	TF
12	Urethane Foam/FRP Skins	494	IM
13	Polypropylene Foam/FRP Skins	492	TF
14	Acrylic/FRP Skin Reinforced	491	TF
15	FRP/Plywood/FRP	490	SP
16	Steel/Styrofoam/Steel	489	SP
17	Polycarbonate/Urethane Foam	487	TF
18	FRP/Urethane Foam/FRP; Al Edges	486	FW
19	PE/FRP Core	483	RM
20	FRP/Urethane Foam/FRP; Steel Edges	479	FW
21	Glass Reinforced Polycarbonate, Structl. Foam	474	IM
22	PE Foam/FRP Core	470	RM
23	Al/Plywood/Al	466	SP
24	FRP	465	IM,FW
25	Al/Paper Honeycomb/Al	455	SP
26	PE/Nylon Core	453	RM
27	Al/Nomex Honeycomb/Al	449	SP
28	ABS Structural Foam	448	TF, IM
29	PE Foam/Al Core	440	RM
29	PE Foam/Nylon Core	440	RM
30	PE Foam/Steel Core	436	RM
31	HDPE/Structural Foam	432	IM





TABLE XX IX .  
FRAME EVALUATION

CRITERIA	VALUE	FRAMES - ISO LOADS						FRAMES - ENVIRONMENTAL LOADS					
		Rack Resisters			No Rack Resisters			Rack Resisters			No Rack Resisters		
		Steel	Aluminum	FRP	Steel	Aluminum	FRP	Steel	Aluminum	FRP	Steel	Aluminum	FRP
1. Withstand ISO Loading	10.0	10	10	10	8	8	7	X	X	X	X	X	X
		100	100	100	80	80	70	X	X	X	X	X	X
2. Interior Space	5.0	9	8	7	5	4	4	10	10	10	9	9	9
		45	40	35	25	20	20	50	50	50	45	45	45
3. Access	7.5	5	5	5	8	8	8	5	5	5	8	8	8
		37.5	37.5	37.5	60.0	60.0	60.0	37.5	37.5	37.5	60.0	60.0	60.0
4. Mobilizer Attachment	2.5	9	8	5	9	8	5	X	X	X	X	X	X
		22.5	20.0	12.5	22.5	20.0	12.5	X	X	X	X	X	X
5. Tow Rings	2.5	9	8	5	9	8	5	X	X	X	X	X	X
		22.5	20.0	12.5	22.5	20.0	12.5	X	X	X	X	X	X
6. Frame/ISO Corner Attachment	9.0	10	8	5	10	8	5	X	X	X	X	X	X
		90	72	45	90	72	45	X	X	X	X	X	X
7. Overall Feasibility	10.0	8	8	7	8	7	7	X	X	X	X	X	X
		80	80	70	80	70	70	X	X	X	X	X	X
8. Standardized Construction	10.0	9	9	9	8	9	7	9	8	9	5	6	9
		90	90	90	80	90	70	90	80	90	50	60	90
9. 5-10 Year Field Life	10.0	6	8	5	6	8	5	6	8	6	6	8	6
		60	80	50	60	80	50	60	80	60	60	80	60
10. Maintenance & Repair	5.0	1	4	3	1	4	3	2	5	4	3	5	4
		5	20	15	5	20	15	10	25	20	15	15	20
11. Weight	5.0	3	9	6	1	7	5	5	9	8	4	8	7
		15	45	30	5	35	25	25	45	40	20	40	35
COMPOSITE SCORE		567.	604.	497.	520.	567.	450.	252.	317.	297.	295.	355.	355.

X = Not Applicable

### Structural Frames

Four basic frames are covered in the above evaluation: Frames with and without rack-resisters for ISO load requirements, and frames with and without rack-resisters for only environmental loads. Three materials (Aluminum, steel, and FRP) are considered.

From the above matrix (Table XXIX), frame configurations were ranked as follows:

I. ISO Loads

<u>Rank</u>	<u>Frame</u>	<u>Score</u>
1	Rack Resisters, Al	604.5
2	Rack Resisters, Steel	567.5
3	No Rack Resisters, Al	567.0
4	No Rack Resisters, Steel	520.0
5	Rack Resisters, FRP	497.5
6	No Rack Resisters, FRP	450.0

II. Environmental Loads

<u>Rank</u>	<u>Frame</u>	<u>Score</u>
1	No Rack Resisters, Al	355.0
2	No Rack Resisters, FRP	355.0
3	Rack Resisters, Al	317.0
4	Rack Resisters, FRP	297.5
5	No Rack Resisters, Steel	295.0
6	Rack Resisters, Steel	252.5

Results

Review of the four areas of design alternatives evaluated above and selection of the top-ranking elements from each area, gave the following results.

1. Design Configuration - Simple frame and panel designs out-ranked all other configurations; top-ranked manufacturing process from a configuration standpoint was sandwich panel technology.
2. Process - Evaluation of manufacturing processes indicate sandwich panel technology as the most suitable method for producing shelter containers.

3. Materials - Material performance evaluation clearly favored FRP-skinned, low-density core composites. These materials are most suitably used in sandwich panel-production methods and in filament winding methods.
4. Frames - The top-ranking frame for withstanding ISO load requirements was an aluminum frame with rack resisters. FRP and aluminum frames without rack resisters were the choices for environmental-load-only applications.

The above results indicate that a basic panel design utilizing FRP-composite sandwich panels and an aluminum ISO frame would be the optimum combination of elements.

It is apparent from the evaluation that the other alternatives all have limitations in different areas which render them less desirable prospects.

Filament Winding - a long-considered desirable candidate because of the properties of the materials involved and the benefits inherent with a monocoque core, fell down in the design configuration area. Access requirements necessitated the use of complex folding panels which tend to limit modularity thereby increasing the number of special, non-common parts.

Rotomolded configurations ranked high in the design configuration area, but severe shortcomings were found when considering production feasibility. Much development work is needed to successfully manufacture shelter container cores by encapsulating a frame and wall matrix. Even if produced successfully, the advantages of such a shelter configuration were questionable.

Injection Molding is at its best when used to produce complex items in high volume. Design configurations, which were evolved specifically for the injection molding process, were found to be no more advantageous from a standardized construction standpoint than basic frame and panel designs. Problems arising from articulation of large injection molded expanding components posed another limitation. Finally, the materials associated with injection molding typically do not perform as well in this application as the FRP composites.

Thermoformed design configurations possess very much the same limitations as the injection molded configurations. Throughout the evaluation, the two processes ranked very closely. The major tradeoff is lower initial investment in machinery and tooling at the expense of

waste material and increased labor costs. Again, the materials typical of the thermoforming process perform worse than the FRP composites.

Recommendations for further development of selected design concepts, which would have the highest probability of successfully arriving at an economical and producible shelter system design which fulfills the multi-modal shelter system requirements within five to seven years, are as follows:

1. Testing of selected frame and panel materials in combination would determine actual sizes and configurations which would be structurally most efficient for the whole system. Static and dynamic tests and evaluations of full-size mock-ups would be required. Development in this area would lead to final specifications for materials, determine actual sizes of shelter components, and make significant contributions to joint design.
2. A simultaneous study of panel manufacturing technology, frame manufacturing process, and assembly procedures should be undertaken in order to design an efficient and systematic shelter production facility.
3. Further MMSS configuration design effort would be required. This effort would first concentrate on functional requirements. Projection and definition of Army/1985 needs would be required. Shelter functions would be determined, design considerations would be established, and an array of functional design concepts would be described with universality of components as the ultimate goal.

The second stage design effort would come at the completion of both the material testing and of the functional design study. This final level would describe specifically all components of the total shelter system. Production prototypes would be built and tested prior to mass-production of the shelter system.

### Conclusion

This technical report was the result of efforts to advance the state-of-the-art of shelter design by investigating the future capabilities of potentially new shelter production methods, by searching out possibly better shelter materials, and by evolving design configurations suitable for the various production methods and materials which would fulfill the requirements of the Multi-Modal Shelter System concept. Evaluation of the numerous elements considered

resulted in an overall design concept favoring a basic frame and panel design configuration which uses FRP composite sandwich panels and an aluminum ISO frame.

## BIBLIOGRAPHY

- Alexander, James M., W. R. Wakefield, K. H. Merkel, B. Bahramiam, "Advanced Modular Shelters for Small and Medium Size Shelter Applications," University of Cincinnati, AFAPL-TR-70-25, 1970
- Aluminum Company of America, Alcoa Aluminum Handbook. Pittsburgh, Pa. 1967
- American Institute of Steel Construction, Inc., Manual of Steel Construction, 7th Edition, 1970
- "And Now, A Structural Foam Bike," Modern Plastics, Volume 50, Number 4, April, 1973. pp. 73-74
- Architectural Research Laboratory, University of Michigan, Structural Potential of Foam Plastics for Housing in Underdeveloped Areas, Ann Arbor, Michigan, 1966
- BASF. BASF Plastics, Third Edition. Ludwigshafen, West Germany. 1971
- Benjamin, W., H. Schut, R. Jarmuth, and B. Desborough. "Rotational Molded Plastic Tricon Containers", The Boeing Company, Manufacturing Research and Development, Commercial Airplane Group. Kenton, Washington. 1972
- Berger, S., et al., "A Critical Analysis of the State of the Art in Containerization", Control Systems Research, Inc., Arlington, Va., 1970
- Brady, George S., Materials Handbook, 10th Edition, McGraw Hill Inc., 1971
- Buxton, O. E. Jr., "Analysis of Sandwich Material", The Ohio State University Research Foundation, RADC-TR-69-402. 1969
- Cagle, Charles V., Adhesive Bonding. New York: McGraw-Hill Book Company, 1968
- Center for Housing and Environmental Studies, College of Architecture, Art, and Planning, Cornell University, Ithaca, N. Y., The New Building Block, 1968
- Cowdell, R. B., R. A. Hupp., J. N. O'Leary, "RFI Attenuating Materials and Structures - An Analysis and Conceptual Design", Genisco Technology Corporation, AFAPL-TR-69-89, 1969

Department of Defense, Structural Sandwich Composites, Military Handbook MIL-HDBK-23A, Washington, D.C. 1968

Design Research Collaborative, Lightweight Shelter Seminar Proceedings, University of Cincinnati, Cincinnati, Ohio June, 1971.

Dietz, Albert G. H., Plastics for Architects and Builders. The M.I.T. Press. Cambridge, Mass. 1969

Dow Chemical Company (The), Design Engineering Data. Midland, Michigan. 1965

"Foam on the Rise", Industrial Design, Vol No. 20/4, May, 1973.

"Get Set for Big Action in Big Thermoforms", Modern Plastics, Vol. 50, No. 2, Feb., 1973.

Goldsworthy, W. Brandt, "Pultrusion - The Most Rapidly Growing Tonnage Market for Reinforced Plastics End Products", "Reinforced Plastics 71", Karlovg-Varg, Czechoslovakia, 1971

Goldsworthy, W. Brandt, "The Rapidly Expanding Use of Reinforced Plastics Composites/Pultruded Profiles in Architecture and Construction". Goldsworthy Engineering, Inc. Torrance, Canada

Hexcel, Design Handbook for Honeycomb Sandwich Structures. Dublin, California. 1971

Higdon, Archie, E. H. Ohlsen, W. B. Stiles, J. A. Weese. Mechanics of Materials, 2nd Edition, John Wiley & Sons, Inc. 1967

International Standards Organization, "ISO Recommendation R-668", February, 1968.

International Standards Organization, "ISO Recommendation R-1161", January, 1970

Kleinlogel, A., Rigid Frame Formulas, Frederick Ungar Publishing Co., 1952

Koppers Engineered Products, Inc., Extren - Glass Reinforced Structural Engineering Manual. Pittsburgh, Pa. 1969

Lindberg, R. A., Processes and Materials of Manufacture, 4th Edition, Allyn and Bacon Inc., Boston: 1967

- Mobay Chemical Company, "Urethane Emergency Shelters Foamed on Site to Aid Nicaragua Earthquake Homeless, Mobay Polygram, Number 50, Summer, 1973. Pittsburgh, Pa. 1973
- Modern Plastics Encyclopedia, Vol. 50, 1973-1974, New York: McGraw-Hill, Inc. 1973
- Modigliani, Piero, "Glasurethane - A New Dimension in Reinforced Plastics" 25th Annual Technical Conference, Society of the Plastics Industry, Reinforced Plastics-Composites Division, 1970.
- Montrey, H. M., and E. W. Kuenzi, "Design Parameters for Torsion of Sandwich Strips Having Trapezoidal, Rectangular, and Triangular Cross-Sections", Forest Products Laboratory, U.S.A.D. Forest Service, Madison, Wisconsin. 1972
- "New Filament-Winding Technique Earns UL Label for Gasoline Tanks", Modern Plastics, Volume 50, Number 7, July. 1973
- Norris, Charles H. and John B. Wilbur, Elementary Structural Analysis, 2nd Edition, McGraw-Hill, Inc., 1960
- Owens-Corning Fiberglas Corporation, Fiberglas-Reinforced Plastics. Toledo, Ohio 1969
- Parker, Harry, Simplified Mechanics and Strength of Materials, 2nd Edition, John Wiley & Sons, Inc. 1961
- Perry, Robert H., Engineering Manual, McGraw Hill, Inc.
- "Plan Your Line for the Payoff in Molding Structural Foam", Modern Plastics. Vol. 50, No. 4. April, 1973
- Plastics Technology's Processing Handbook, 1968. New York 1968. Bill Brothers Publishing Corporation.
- "Pultrusion Breakthrough Opens New Markets", Plastics World, March, 1971.
- "Push A Button, Wind a Reefer", Modern Plastics, Vol. 49, No. 2, Feb. 1972
- Reinforced Plastics/Composites Institute, Society of the Plastics Industry, Twenty-Eighth Annual Conference Proceedings, Washington, D. C., 1973.
- Richards, Cedric W., Engineering Materials Science, Wadsworth Publishing Company, Inc., 1961
- Sherwood, G. E., "Longtime Performance of Sandwich Panels in Forest Products Laboratory Experimental Unit", Forest Products Laboratory, U.S.D.A. Forest Service, Madison, Wisconsin. 1970

Society of the Plastics Industry (The), "Structural Foam",  
New York

Structures Division and Civil Engineering Systems Laboratory,  
Department of Civil Engineering, Massachusetts  
Institute of Technology, ICES STRUDL-II, The Structural  
Design Language Engineering Users Manual, Vols. I, II,  
III, 1st Edition, 1968.

Technical Products Division, The Brunswick Corporation, "A  
Unique Concept for Transportable Shelter Construction".

"Thermoformed Plastic Parts", Machine Design, January, 1971.

United States Rubber Company (The), "The Portabuilding",  
Warsaw, Indiana.

"Vehicle Chassis of Sandwich Construction", Modern Plastics,  
Vol. 50, No. 7, July, 1973

Zwolinski, J. A., The Container Material Study: A Treatise  
on the Evolution and Continued Progression of Container-  
ization, U. S. Army Mobility Equipment Research and  
Development Center, Fort Belvoir, Va. 1973.

APPENDIX A

THE STRUCTURAL DESIGN LANGUAGE  
COMPUTER RUN (STRUDL)

APPENDIX A

STRUJDI 'ANAI 1' '20 FOOT FRAME ANALYSIS'

The Structural Design Language  
Computer Run (STRUJDL)

```

*****
*
*           ICFS STRUJDI-II
*       THE STRUCTURAL DESIGN LANGUAGE
*
*   CIVIL ENGINEERING SYSTEMS LABORATORY
*   MASSACHUSETTS INSTITUTE OF TECHNOLOGY
*   CAMBRIDGE, MASSACHUSETTS
*   V2 40   OCTOBER, 1970
*   15:25:25   10/01/73
*
*****

```

```

DERUG ALL
TYPE SPACE FRAME
UNITS INCHES KIPS
JOINT COORDINATES
1  0.  0.  0.  SUPPORT
2  0.  96.  0.
3  0.  96.  240.
4  96.  96.  240.
5  96.  96.  0.
6  96.  0.  0.  SUPPORT
7  0.  0.  240.  SUPPORT
8  96.  0.  240.  SUPPORT
9  48.  48.  240.
10 48.  96.  120.
11 48.  48.  0.
MEMBER INCIDENCES
1  1  2
2  2  3
3  3  4
4  4  5
5  2  5
6  5  6
7  4  8
8  3  7

```

10

9 7 9  
 10 3 9  
 11 4 9  
 12 8 9  
 13 3 10  
 14 2 10  
 15 5 10  
 16 4 10  
 17 1 11  
 18 2 11  
 19 5 11  
 20 6 11

LOADING 'ONE' 'STACKING REQ'

JOINT 2 TO 5 LOAD FORCE Y -108.

LOADING 'TWO' 'RACKING REQ'

JOINT 3 LOAD FORCE X 35.

LOADING 'THREE' 'ROOF LOAD'

MEMBER LOADS

2 FORCE Y GLOBAL UNIFORM -.015

4 FORCE Y GLOBAL UNIFORM -.015

LOADING 'FOUR' 'WIND ON LONG FACE'

MEMBER LOADS

1 FORCE X GLOBAL UNIFORM .01865

8 FORCE X GLOBAL UNIFORM .01865

LOADING 'FIVE' 'WIND ON SHORT FACE 1'

MEMBER LOADS

7 FORCE Z GLOBAL UNIFORM -.00746

8 FORCE Z GLOBAL UNIFORM -.00746

LOADING 'SIX' 'WIND ON SHORT FACE 2'

MEMBER LOADS

1 FORCE Z GLOBAL UNIFORM .00746

6 FORCE Z GLOBAL UNIFORM .00746

LOADING COMBINATION 34 -

COMBINE 'THREE' 1.0 'FOUR' 1.0

193

COMBINE \*THREE\* 1.0 \*FOUR\* 1.0

LOADING COMBINATION 35 -  
COMBINE \*THREE\* 1.0 \*FIVE\* 1.0

LOADING COMBINATION 1234 -  
COMBINE \*ONE\* 1.0 \*TWO\* 1.0 \*THREE\* 1.0 \*FOUR\* 1.0

LOADING COMBINATION 1235 -  
COMBINE \*ONE\* 1.0 \*TWO\* 1.0 \*THREE\* 1.0 \*FIVE\* 1.0

LOADING COMBINATION 1236 -  
COMBINE \*ONE\* 1.0 \*TWO\* 1.0 \*THREE\* 1.0 \*SIX\* 1.0

\$ MATERIAL -- STEEL

CONSTANTS F 29000 ALL

G 12000 ALL

MEMBER 1 PROPERTIES PRIS AX 4.95 IX 288000 IY 10.2 IZ 10.2

MEMBER 2 PROPERTIES PRIS AX 3.09 IX 10500 IY 5.29 IZ 5.29

MEMBER 3 PROPERTIES PRIS AX 3.09 IX 10500 IY 5.29 IZ 5.29

MEMBER 4 PROPERTIES PRIS AX 3.09 IX 10500 IY 5.29 IZ 5.29

MEMBER 5 PROPERTIES PRIS AX 3.09 IX 10500 IY 5.29 IZ 5.29

MEMBER 6 PROPERTIES PRIS AX 4.95 IX 288000 IY 10.2 IZ 10.2

MEMBER 7 PROPERTIES PRIS AX 4.95 IX 288000 IY 10.2 IZ 10.2

MEMBER 8 PROPERTIES PRIS AX 4.95 IX 288000 IY 10.2 IZ 10.2

MEMBER 9 TO 20 PROPERTIES PRIS AX 1.0 IX 467.4 IY .0625 IZ .0625

STIFFNESS ANALYSIS

OUTPUT DECIMAL 2

LOADING LIST \*ONE\* \*TWO\* .34 .35 .1234 .1235 .1236

LIST FORCES LOADS REACTIONS DISPLACEMENTS

6

\*\*\*\*\*  
 \*RESULTS OF LATEST ANALYSIS\*  
 \*\*\*\*\*

PROBLEM - ANA1 1 TITLE - 20 FOOT FRAME ANALYSIS

ACTIVE UNITS INCH KIP RAD DEGF SEC

ACTIVE STRUCTURE TYPE SPACE FRAME

ACTIVE COORDINATE AXES X Y Z

LOADING - ONE STACKING REC

MEMBER FORCES

195

MEMBER	JOINT	FORCE			MOMENT		
		AXIAL	SHEAR Y	SHEAR Z	TORSIONAL	BENDING Y	BENDING Z
1	1	101.16	-0.01	-0.00	0.00	0.00	-0.50
1	2	-101.16	0.01	0.00	-0.00	0.11	-0.50
2	2	0.22	-0.00	-0.00	0.00	-0.00	0.01
2	3	-0.22	0.00	0.00	0.00	0.00	-0.01
3	3	-6.74	0.00	-0.00	0.00	0.00	0.05
3	4	6.74	-0.00	0.00	0.00	-0.00	-0.05
4	4	0.22	-0.00	-0.00	0.00	-0.00	0.01
4	5	-0.22	0.00	0.00	0.00	0.00	-0.01
5	2	-6.74	0.00	0.00	0.00	-0.00	0.05
5	5	6.74	-0.00	-0.00	0.00	0.00	-0.05
6	5	101.16	0.01	0.00	-0.00	-0.11	0.50
6	6	-101.16	-0.01	-0.00	0.00	0.00	0.50
7	4	101.16	0.01	-0.00	0.00	0.11	0.50
7	8	-101.16	-0.01	0.01	-0.00	0.00	0.50
8	3	101.16	-0.01	-0.00	-0.00	0.11	-0.50
8	7	-101.16	0.01	0.00	0.00	0.00	-0.50
9	7	9.67	0.00	0.00	-0.13	-0.00	0.05
9	9	-9.67	-0.00	-0.00	0.13	-0.00	0.05
10	3	9.67	-0.00	-0.00	0.13	0.00	-0.05
10	9	-9.67	0.00	0.00	-0.13	0.00	-0.05
11	4	9.67	-0.00	0.00	-0.13	-0.00	-0.05
11	9	-9.67	0.00	-0.00	0.13	-0.00	-0.05
12	8	9.67	0.00	-0.00	0.13	0.00	0.05
12	9	-9.67	-0.00	0.00	-0.13	0.00	0.05
13	3	-0.24	0.00	-0.00	-0.00	0.00	0.00
13	10	0.24	-0.00	0.00	0.00	0.00	-0.00
14	2	-0.24	0.00	0.00	0.00	-0.00	0.00
14	10	0.24	-0.00	-0.00	-0.00	0.00	-0.00
15	5	-0.24	0.00	-0.00	-0.00	-0.00	0.00
15	10	0.24	-0.00	0.00	0.00	0.00	-0.00
16	4	-0.24	0.00	0.00	0.00	-0.00	0.00
16	10	0.24	-0.00	-0.00	-0.00	0.00	-0.00

17	1	9.67	0.00	0.00				
17	11	-9.67	-0.00	-0.00				
18	2	9.67	-0.00	0.00				
18	11	-9.67	-0.00	-0.00				
19	5	9.67	-0.00	-0.00				
19	11	-9.67	0.00	0.00				
20	5	9.67	0.00	0.00				
20	11	-9.67	-0.00	-0.00				

RESULTANT JOINT LOADS - SUPPORTS

JOINT		FORCE			MOMENT		
		X FORCE	Y FORCE	Z FORCE	X MOMENT	Y MOMENT	Z MOMENT
1	GLOBAL	6.85	108.00	-0.00	0.01	0.12	-0.55
6	GLOBAL	-6.85	108.00	-0.00	0.01	-0.12	0.55
7	GLOBAL	6.85	108.00	0.00	-0.01	-0.12	-0.55
8	GLOBAL	-6.85	108.00	0.00	-0.01	0.12	0.55

RESULTANT JOINT LOADS - FREE JOINTS

JOINT		FORCE			MOMENT		
		X FORCE	Y FORCE	Z FORCE	X MOMENT	Y MOMENT	Z MOMENT
2	GLOBAL	-0.00	-108.00	-0.00	-0.00	-0.00	-0.00
3	GLOBAL	-0.00	-108.00	0.00	0.00	-0.00	-0.00
4	GLOBAL	0.00	-108.00	0.00	-0.00	0.00	0.00
5	GLOBAL	0.00	-108.00	-0.00	-0.00	-0.00	0.00
9	GLOBAL	0.00	-0.00	-0.00	-0.00	0.00	0.00
10	GLOBAL	0.00	-0.00	0.00	-0.00	-0.00	-0.00
11	GLOBAL	0.00	-0.00	0.00	-0.00	0.00	0.00

RESULTANT JOINT DISPLACEMENTS - SUPPORTS

JOINT		DISPLACEMENT			ROTATION		
		X DISP.	Y DISP.	Z DISP.	X ROT.	Y ROT.	Z ROT.
1	GLOBAL	0.0	0.0	0.0	0.0	0.0	0.0
6	GLOBAL	0.0	0.0	0.0	0.0	0.0	0.0
7	GLOBAL	0.0	0.0	0.0	0.0	0.0	0.0
8	GLOBAL	0.0	0.0	0.0	0.0	0.0	0.0

RESULTANT JOINT DISPLACEMENTS - FREE JOINTS

JOINT		DISPLACEMENT			ROTATION		
		X DISP.	Y DISP.	Z DISP.	X ROT.	Y ROT.	Z ROT.
2	GLOBAL	-0.00	-0.07	0.00	-0.00	-0.00	0.00
3	GLOBAL	-0.00	-0.07	-0.00	0.00	0.00	0.00
4	GLOBAL	0.00	-0.07	-0.00	0.00	-0.00	-0.00
5	GLOBAL	0.00	-0.07	0.00	-0.00	0.00	-0.00
9	GLOBAL	0.00	-0.03	-0.00	0.00	0.00	0.00
10	GLOBAL	0.00	-0.07	0.00	-0.00	-0.00	-0.00
11	GLOBAL	0.00	-0.03	0.00	-0.00	0.00	0.00

LOADING - TWO

PACKING REQ

## MEMBER FORCES

MEMBER	JOINT	FORCE			MOMENT		
		AXIAL	SHEAR Y	SHEAR Z	X MOMENT	Y MOMENT	Z MOMENT
1	1	-0.42	-0.14	-0.13	0.00	0.00	-4.43
1	2	0.42	0.14	0.13	0.00	0.00	-4.43
2	2	-0.27	-0.00	0.02	17.07	-2.86	-0.20
2	3	0.27	0.00	-0.02	-17.07	-2.86	-0.14
3	3	16.48	-0.12	0.13	0.00	-6.37	-5.67
3	4	-16.48	0.12	-0.13	-0.00	-6.37	-5.66
4	4	-0.27	-0.00	0.02	15.30	-2.52	-1.18
4	5	0.27	0.00	-0.02	-15.30	-2.52	-0.17
5	2	-0.10	-0.16	0.13	0.00	-6.37	-7.56
5	5	0.10	0.16	-0.13	-0.00	-6.37	-7.47
6	5	0.43	-0.14	-0.13	-8.94	6.24	-8.99
6	6	-0.43	0.14	0.13	8.94	6.23	-4.22
7	4	16.09	0.49	-0.13	-9.13	5.69	20.97
7	8	-16.09	-0.49	0.13	9.13	6.03	25.92
8	3	-17.85	0.55	0.13	-4.22	-6.23	23.91
8	7	17.85	-0.55	-0.13	4.22	-6.23	29.09
9	7	-22.59	-0.00	0.00	0.17	0.00	0.07
9	9	22.59	0.00	0.00	-0.17	0.00	0.01
10	3	25.08	0.00	0.00	-0.06	-0.00	0.04
10	9	-25.08	-0.00	-0.00	0.06	-0.00	0.02
11	4	-22.59	-0.00	0.00	-0.24	-0.07	0.00
11	9	22.59	0.00	-0.00	-0.24	-0.07	0.02
12	8	25.08	-0.00	0.00	-0.13	-0.00	0.06
12	9	-25.08	0.00	-0.00	0.13	-0.00	-0.00
13	3	0.57	-0.00	0.00	1.29	-0.03	-0.02
13	10	-0.57	0.00	-0.00	-1.29	-0.01	-0.02
14	2	0.01	-0.00	0.00	0.02	-0.03	-0.03
14	10	-0.01	0.00	-0.00	-0.02	-0.00	-0.03
15	5	0.57	0.00	0.00	1.29	-0.03	0.02
15	10	-0.57	-0.00	-0.00	-1.29	0.00	0.02
16	4	0.01	0.00	0.00	0.04	-0.02	0.02
16	10	-0.01	-0.00	-0.00	-0.04	0.01	0.02
17	1	-0.39	0.00	0.00	-0.11	-0.00	0.01
17	11	0.39	-0.00	-0.00	0.11	-0.00	0.02
18	2	0.37	-0.00	0.00	0.22	-0.07	-0.07
18	11	-0.37	0.00	-0.00	-0.22	-0.07	-0.02
19	5	-0.39	0.00	0.00	-0.04	-0.00	0.07
19	11	0.39	-0.00	-0.00	0.04	-0.00	0.02
20	6	0.37	-0.00	-0.00	0.15	0.00	-0.01
20	11	-0.37	0.00	0.00	-0.15	0.00	-0.02

## RESULTANT JOINT LOADS - SUPPORTS

JOINT	MEMBER	FORCE			MOMENT		
		X FORCE	Y FORCE	Z FORCE	X MOMENT	Y MOMENT	Z MOMENT
1	GI ORAI	-0.13	-0.70	-0.13	-4.11	-5.46	-4.44
6	GI ORAI	-0.13	0.70	0.13	4.11	-4.21	-4.21
7	GI ORAI	-16.53	-33.82	-0.13	-9.11	-5.10	29.17
8	GI ORAI	-18.22	33.82	0.13	9.11	-9.23	25.90

## RESULTANT JOINT LOADS - FREE JOINTS

JOINT		FORCE			MOMENT		
		X FORCE	Y FORCE	Z FORCE	X MOMENT	Y MOMENT	Z MOMENT
2	GLOBAL	0.00	-0.00	0.00	-0.00	-0.00	-0.00
3	GLOBAL	35.00	-0.00	-0.00	0.00	-0.00	0.00
4	GLOBAL	0.00	0.00	0.00	0.00	0.00	0.00
5	GLOBAL	0.00	0.00	-0.00	-0.00	0.00	0.00
9	GLOBAL	-0.00	0.00	-0.00	0.00	0.00	0.00
10	GLOBAL	-0.00	0.00	0.00	0.00	-0.00	-0.00
11	GLOBAL	-0.00	-0.00	0.00	-0.00	-0.00	0.00

RESULTANT JOINT DISPLACEMENTS - SUPPORTS

JOINT		DISPLACEMENT			ROTATION		
		X DISP.	Y DISP.	Z DISP.	X ROT.	Y ROT.	Z ROT.
1	GLOBAL	0.0	0.0	0.0	0.0	0.0	0.0
6	GLOBAL	0.0	0.0	0.0	0.0	0.0	0.0
7	GLOBAL	0.0	0.0	0.0	0.0	0.0	0.0
8	GLOBAL	0.0	0.0	0.0	0.0	0.0	0.0

RESULTANT JOINT DISPLACEMENTS - FREE JOINTS

JOINT		DISPLACEMENT			ROTATION		
		X DISP.	Y DISP.	Z DISP.	X ROT.	Y ROT.	Z ROT.
2	GLOBAL	0.00	0.00	0.03	0.00	0.00	-0.00
3	GLOBAL	0.18	0.01	0.03	-0.00	0.00	-0.00
4	GLOBAL	0.16	-0.01	-0.03	-0.00	-0.00	-0.00
5	GLOBAL	0.00	-0.00	-0.03	0.00	0.00	-0.00
9	GLOBAL	0.08	-0.00	0.00	-0.00	-0.00	-0.00
10	GLOBAL	0.09	-0.00	0.00	0.00	0.00	-0.00
11	GLOBAL	0.00	0.00	-0.00	0.00	-0.00	0.00

LOADING - 34

MEMBER FORCES

MEMBER	JOINT	FORCE			MOMENT		
		AXIAL	SHEAR Y	SHEAR Z	TORSIONAL	BENDING Y	BENDING Z
1	1	1.34	0.89	0.37	-40.04	-11.86	14.32
1	2	-1.34	0.90	-0.37	40.04	-23.84	-15.08
2	2	0.29	1.80	0.00	0.0	0.00	69.52
2	3	-0.29	1.80	-0.00	0.0	-0.00	-69.52
3	3	0.35	0.06	0.00	-0.01	-0.00	1.51
3	4	-0.35	-0.06	-0.00	0.01	0.00	-1.51
4	4	0.29	1.80	0.00	0.0	0.00	69.52
4	5	-0.29	1.80	-0.00	0.0	-0.00	-69.52
5	2	0.35	0.06	0.00	0.01	0.00	1.51
5	5	-0.35	-0.06	-0.00	-0.01	-0.00	-1.51
6	5	1.98	0.15	-0.37	-40.04	23.84	9.35
6	6	-1.98	-0.15	0.37	40.04	-23.84	-9.35
7	4	1.98	0.15	-0.37	-40.04	23.84	9.35
7	8	-1.98	-0.15	0.37	40.04	-23.84	-9.35
8	2	1.34	0.89	0.37	-40.04	-11.86	14.32

U

8	7	1.34	-0.73	0.00	0.00	0.00	0.00	0.00
9	7	-0.34	-0.00	-0.00	-0.00	56.53	0.00	-0.00
9	9	0.34	0.00	0.00	0.00	-56.53	0.00	-0.01
10	3	0.73	-0.00	0.00	0.00	-56.75	-0.13	-0.02
10	9	-0.73	0.00	-0.00	-0.00	56.75	-0.09	-0.01
11	4	-0.34	-0.00	-0.00	-0.00	56.75	0.13	-0.07
11	9	0.34	0.00	0.00	0.00	-56.75	0.00	-0.03
12	8	0.73	0.00	0.00	0.00	-56.53	-0.09	0.00
12	9	-0.73	-0.00	-0.00	-0.00	56.53	-0.13	0.01
13	3	0.10	0.00	0.00	0.00	-14.64	-0.00	-0.02
13	10	-0.10	-0.00	-0.00	-0.00	14.64	-0.00	0.04
14	2	0.10	0.00	0.00	0.00	-14.64	0.00	-0.02
14	10	-0.10	-0.00	-0.00	-0.00	14.64	0.00	0.04
15	5	0.10	-0.00	0.00	0.00	-14.63	-0.00	-0.04
15	10	-0.10	0.00	-0.00	-0.00	14.63	-0.00	0.02
16	4	0.10	-0.00	0.00	0.00	-14.63	0.00	-0.04
16	10	-0.10	0.00	-0.00	-0.00	14.63	0.00	0.02
17	1	-0.34	-0.00	-0.00	-0.00	56.53	-0.09	-0.00
17	11	0.34	0.00	-0.00	-0.00	-56.53	-0.13	-0.01
18	2	0.73	-0.00	-0.00	-0.00	56.75	0.13	-0.02
18	11	-0.73	0.00	0.00	0.00	-56.75	0.09	-0.01
19	5	-0.34	-0.00	0.00	0.00	-56.75	-0.13	-0.07
19	11	0.34	0.00	-0.00	-0.00	56.75	-0.09	-0.03
20	6	0.73	0.00	0.00	0.00	-56.53	0.09	-0.00
20	11	-0.73	-0.00	0.00	0.00	56.53	0.13	0.01

RESULTANT JOINT LOADS - SUPPORTS

JOINT		FORCE			MOMENT		
		X FORCE	Y FORCE	Z FORCE	X MOMENT	Y MOMENT	Z MOMENT
1	GLOBAL	-1.12	1.11	0.38	-28.03	-80.08	14.32
6	GLOBAL	-0.67	2.49	0.38	-28.03	80.08	5.01
7	GLOBAL	-1.12	1.11	-0.38	28.03	80.08	-14.32
8	GLOBAL	-0.67	2.49	-0.38	28.03	-80.08	5.01

RESULTANT JOINT LOADS - FREE JOINTS

JOINT		FORCE			MOMENT		
		X FORCE	Y FORCE	Z FORCE	X MOMENT	Y MOMENT	Z MOMENT
2	GLOBAL	-0.00	0.00	-0.00	0.00	-0.00	0.00
3	GLOBAL	-0.00	0.00	0.00	0.00	0.00	-0.00
4	GLOBAL	0.00	0.00	-0.00	-0.00	-0.00	0.00
5	GLOBAL	0.00	0.00	-0.00	-0.00	0.00	-0.00
9	GLOBAL	0.00	-0.00	-0.00	0.00	0.00	-0.00
10	GLOBAL	0.00	0.00	-0.00	-0.00	0.00	0.00
11	GLOBAL	0.00	-0.00	0.00	0.00	0.00	-0.00

RESULTANT JOINT DISPLACEMENTS - SUPPORTS

JOINT		DISPLACEMENT			ROTATION		
		X DISP.	Y DISP.	Z DISP.	X ROT.	Y ROT.	Z ROT.
1	GLOBAL	0.0	0.0	0.0	0.0	0.0	0.0
6	GLOBAL	0.0	0.0	0.0	0.0	0.0	0.0
7	GLOBAL	0.0	0.0	0.0	0.0	0.0	0.0
8	GLOBAL	0.0	0.0	0.0	0.0	0.0	0.0

199

RESULTANT JOINT DISPLACEMENTS - FREE JOINTS

JOINT		DISPLACEMENT			ROTATION		
		X DISP.	Y DISP.	Z DISP.	X ROT.	Y ROT.	Z ROT.
2	GLOBAL	0.00	-0.00	0.00	0.00	0.00	-0.00
3	GLOBAL	0.00	-0.00	-0.00	-0.00	-0.00	-0.00
4	GLOBAL	0.00	-0.00	-0.00	-0.00	-0.00	-0.00
5	GLOBAL	0.00	-0.00	0.00	0.00	-0.00	0.00
9	GLOBAL	0.00	-0.00	0.02	-0.00	0.00	-0.00
10	GLOBAL	0.00	-0.13	-0.00	0.00	0.00	0.00
11	GLOBAL	0.00	-0.00	-0.02	0.00	-0.00	-0.00

LOADING - 35

MEMBER FORCES

MEMBER	JOINT	FORCE			MOMENT		
		AXIAL	SHEAR Y	SHEAR Z	TORSIONAL	BENDING Y	BENDING Z
1	1	1.69	-0.10	0.54	-35.30	-20.86	-3.34
1	2	-1.69	0.10	-0.54	35.30	-31.40	-6.67
2	2	0.44	1.81	0.00	0.03	0.00	70.34
2	3	-0.44	1.79	0.00	-0.03	-0.00	-68.76
3	3	-0.06	-0.00	-0.00	-0.00	-0.00	-1.73
4	4	0.44	1.79	-0.00	-0.03	0.00	68.76
4	5	-0.44	1.81	0.00	0.03	-0.00	-70.34
5	2	-0.06	0.00	0.00	0.00	0.00	-1.73
5	5	0.06	0.00	0.00	0.00	-0.00	1.73
6	5	1.69	0.10	-0.54	35.30	31.40	6.67
6	4	-1.69	-0.10	0.54	-35.30	-31.40	-6.67
7	4	1.68	0.10	0.55	-43.83	-21.37	6.67
7	8	-1.68	-0.10	0.17	43.83	3.18	3.34
8	3	1.68	-0.10	0.55	-43.83	-21.37	6.67
8	7	-1.68	0.10	0.17	43.83	3.18	-3.34
9	7	0.17	0.00	-0.00	61.96	0.04	0.00
9	9	-0.17	-0.00	0.00	-61.96	-0.04	-0.00
10	3	0.16	-0.00	0.00	-62.07	-0.04	-0.06
10	9	-0.16	0.00	-0.00	62.07	0.04	-0.03
11	4	0.16	-0.00	-0.00	-62.07	-0.04	-0.06
11	9	-0.16	0.00	0.00	62.07	0.04	-0.03
12	8	0.17	0.00	0.00	-61.96	-0.04	0.00
12	9	-0.17	-0.00	-0.00	61.96	0.04	-0.00
13	3	0.12	-0.00	-0.00	-9.16	0.00	-0.04
13	10	-0.12	0.00	0.00	9.16	0.00	0.01
14	2	0.12	0.00	0.00	-9.08	-0.00	-0.01
14	10	-0.12	-0.00	-0.00	9.08	0.00	0.04
15	5	0.12	0.00	-0.00	-9.08	0.00	-0.01
15	10	-0.12	-0.00	0.00	9.08	0.00	0.04
16	4	0.12	0.00	0.00	-9.16	-0.00	-0.04
16	10	-0.12	0.00	-0.00	9.16	0.00	0.01
17	1	0.17	0.00	0.00	-49.79	-0.14	0.00
17	11	-0.17	-0.00	-0.00	49.79	0.14	0.00
18	2	0.17	-0.00	-0.00	-50.11	0.18	-0.06
18	11	-0.17	0.00	0.00	50.11	-0.18	0.03
19	5	0.17	-0.00	0.00	-50.11	-0.18	-0.06
19	11	-0.17	0.00	-0.00	50.11	0.18	-0.03
20	4	0.17	0.00	-0.00	-50.11	0.14	0.00

200

20 11 0.17 0.00 0.00 40.71 0.16 0.00

RESULTANT JOINT LOADS - SUPPORTS

JOINT	GLOBAL	FORCE			MOMENT		
		X FORCE	Y FORCE	Z FORCE	X MOMENT	Y MOMENT	Z MOMENT
1	GLOBAL	0.22	1.81	0.55	-14.24	-70.61	-3.34
6	GLOBAL	-0.22	1.81	0.55	-14.24	70.61	3.34
7	GLOBAL	0.22	1.79	0.17	46.97	67.67	-3.34
8	GLOBAL	-0.22	1.79	0.17	46.97	-67.67	3.34

RESULTANT JOINT LOADS - FREE JOINTS

JOINT	GLOBAL	FORCE			MOMENT		
		X FORCE	Y FORCE	Z FORCE	X MOMENT	Y MOMENT	Z MOMENT
2	GLOBAL	0.00	0.00	0.00	0.00	-0.00	0.00
3	GLOBAL	-0.00	0.00	0.00	0.00	0.00	0.00
4	GLOBAL	0.00	0.00	0.00	0.00	0.00	0.00
5	GLOBAL	-0.00	0.00	0.00	-0.00	0.00	-0.00
9	GLOBAL	0.00	0.00	0.00	0.00	0.00	0.00
10	GLOBAL	-0.00	0.00	0.00	-0.00	0.00	0.00
11	GLOBAL	-0.00	0.00	0.00	-0.00	0.00	0.00

RESULTANT JOINT DISPLACEMENTS - SUPPORTS

JOINT	GLOBAL	DISPLACEMENT			ROTATION		
		X DISP.	Y DISP.	Z DISP.	X ROT.	Y ROT.	Z ROT.
1	GLOBAL	0.0	0.0	0.0	0.0	0.0	0.0
6	GLOBAL	0.0	0.0	0.0	0.0	0.0	0.0
7	GLOBAL	0.0	0.0	0.0	0.0	0.0	0.0
8	GLOBAL	0.0	0.0	0.0	0.0	0.0	0.0

RESULTANT JOINT DISPLACEMENTS - FREE JOINTS

JOINT	GLOBAL	DISPLACEMENT			ROTATION		
		X DISP.	Y DISP.	Z DISP.	X ROT.	Y ROT.	Z ROT.
2	GLOBAL	-0.00	-0.00	-0.05	0.00	0.00	-0.00
3	GLOBAL	-0.00	-0.00	-0.05	-0.00	-0.00	-0.00
4	GLOBAL	-0.00	-0.00	-0.05	0.00	0.00	0.00
5	GLOBAL	0.00	-0.00	-0.05	0.00	-0.00	0.00
9	GLOBAL	-0.00	-0.00	-0.00	-0.00	0.00	0.00
10	GLOBAL	-0.00	-0.13	-0.05	-0.00	-0.00	-0.00
11	GLOBAL	-0.00	-0.00	-0.05	0.00	0.00	-0.00

LOADING - 1234

MEMBER FORCES



**APPENDIX B**

**SAMPLE CALCULATIONS FOR STRUCTURAL EFFICIENCY OF A  
FRAME AND PANEL DESIGN CONCEPT VERSUS VARIOUS MONOCOQUE TECHNIQUES**



APPENDIX B

Sample Calculations for Structural Efficiency of A  
Frame and Panel Design Concept Versus Various Monocoque Techniques

Sample Calculations

Frame Design

20' x 8' x 8' Frame      FRP      Woven       $\sigma_{allow} = 27.6 \text{ ksi}$

Member "A"

Most severe loading condition from computer printout:

$P = 16.54 \text{ kips}$        $M_y = 12.5 \text{ k-in}$        $M_z = 68 \text{ k-in}$

Check stress

Try 4 x 4 x .3125

$A = 4.27 \text{ in}^2$        $S = 4.61 \text{ in}^3$

$$\sigma = \frac{16.54}{4.27} + \frac{12.5}{4.61} + \frac{68}{4.61} \approx 21.2 \text{ ksi}$$

. . . OK

Check Buckling

$E = 3.5 \times 10^6 \text{ psi}$        $\sigma_y = 41,250 \text{ psi}$

$A = 4.27 \text{ in}^2$        $I = 9.23 \text{ in}^4$        $r = 1.48 \text{ in}$

$$\frac{KL}{r} = .75(96 \text{ in})/1.48 \text{ in} = 48.6$$

$$S = 48.6 / \left( \pi \sqrt{\frac{3.5 \times 10^6}{.04125}} \right) = 48.6 / (\pi \sqrt{85}) = 1.68$$

$$R = .35 = \frac{P/A}{\sigma_o}$$

$$P/A = .35(41250) = 14.4$$

$$P = 14.4(4.27) = 61.7 \quad \text{No Good}$$

Try 4 x 4 x .5

$$\frac{KL}{r} = \frac{.75(96)}{1.36} \quad r = 1.36 \quad = 53$$

$$S = 53 / (\pi \sqrt{85}) = 1.84$$

$$R = .31 = \frac{P/A}{\sigma_o}$$

$$P/A = .31(41250) = 12,800$$

$$P = 12800(6.14) = 78,500 \text{ k} \quad \text{No Good}$$

Try 5 x 5 x .3125

$$\frac{KL}{r} = \frac{.75(96)}{1.88} = 38.4$$

$$S = 38.4 / (\pi)(9.2) = 1.33$$

$$R = .48 = \frac{P/A}{\sigma_o}$$

$$P/A = .48(41250) = 19,800$$

$$P = 19,800(5.52) = 109 \text{ k} \quad \therefore \text{OK}$$

Use 5 x 5 x .3125

### Member "B"

Most severe loading condition from computer printout:

$$M_z = 67.24 \text{ k-in} \quad T = 39.77 \text{ k-in}$$

$$\sigma = \frac{Mc}{I} \quad S = \frac{M}{\sigma}$$

$$S = 67.24 / \sigma_{\text{allow}}$$

$$S = 67.24 / 27.6 = 2.44 \text{ in}^3$$

Try 3½ x 3½ x .1875

Check Torsional

$$\tau = \frac{Tc}{J}$$

$$\tau = 39.77(1.75)/J$$

$$J = \frac{2b^2d^2}{\frac{b}{t} + \frac{d}{t_w}} = \frac{2(3.5)^4}{2(\frac{3.5}{.1875})} = 150/18.6 = 8.1$$

$$\tau = 39.77(1.75)/8.1 = 8.4 \quad \therefore \text{OK}$$

Use  $3\frac{1}{2} \times 3\frac{1}{2} \times .1875$

### Member "C"

Most severe loading condition from computer printout:

$$P = 17.06 \text{ kips} \quad M_y = 24.86 \text{ k-in}$$

$$M_z = 19.22 \text{ k-in}$$

Try  $3\frac{1}{2} \times 3\frac{1}{2} \times .1875$

$$\sigma = \frac{17.06}{2.39} + \frac{24.86}{2.45} + \frac{19.22}{2.45}$$

$$= 7.2 + 7.85 + 10.1 = 25.1 \quad \therefore \text{OK}$$

Use  $3\frac{1}{2} \times 3\frac{1}{2} \times .1875$

### Filament Winding

ISO loading without frame or rack resistors.

#### A. Longitudinally Wound

Loading

1. Stacking 108k (applied to ISO corner  $6\frac{1}{2}$ " in length)

$$\sigma = \frac{P}{A}$$

$$27,600 = \frac{108,000}{A} = \frac{108,000}{2(6.5)x}$$

$$x = \frac{108}{2(6.5)(27.6)} = .31 \text{ in}$$

### Check Buckling

$$S = .75(L/r) / \sqrt{\pi^2 E / \pi_0}$$
$$= .75(96/.35) / \sqrt{\pi^2 \frac{3.5 \times 10^6}{37.6 \times 10^3}} = \frac{205}{\sqrt{127}} = 5.8$$

$$R = .1 = P/A/\sigma_0$$

$$27600(.1) = 108,000/A$$

$$A = \frac{108}{2.76} = 39 \text{ in}^2$$

$$A = \lambda \cdot d$$

$$d = \frac{39 \text{ in}^2}{4(12 \text{ in})} = .82$$

$$t = .41 \text{ in}$$

### 2. Racking on end panel (MIL-HDBK-23A)

$$35K/96 \text{ in} = 364 \text{ lb/in}$$

$$t = \frac{364}{2(12000)} = .0152 \text{ in}$$

$$F_s = \frac{364}{2(.31)} = 585$$

$$\frac{\lambda F}{E} = .91(585)/3.5 \times 10^6 = .000153$$

$$\frac{b}{a} = 1 \quad \frac{h}{B} = .007 \quad h = .007(96) = .672$$

### 3. Wind on end panel (MIL-HDBK-23A)

$$p = 22.4 \text{ lb/ft}^2 / 144 = .156$$

$$\frac{p}{F} = \frac{.156}{200} = .00078$$

$$\frac{\lambda F}{E} = .91(200)/3.5 \times 10^6 = .000052$$

$$\frac{h}{B} = .0094 \quad h = .9$$

4. Snow

$$p = .278 \quad \frac{p}{200} = \frac{.278}{200} = .00139$$

$$\frac{\lambda F}{E} = .91(200)/3.5 \times 10^6 = .000052$$

$$\frac{h}{b} = \frac{1.25}{96} = .013$$

$$2000 \frac{p}{200} = .000139 \quad \frac{h}{b} = .007$$

$$\frac{\lambda F}{E} = .91(2000)/3.5 \times 10^6 = .00052 \quad \frac{h}{b} = .007$$

$$\frac{d}{h} = .05$$

$$\text{Use } t = 45 \text{ in} \quad d = 1.5 \text{ in}$$

B. Transversally Wound

Bending moments will predominate.  
Assume 1/4 rack taken by roof; therefore 3/4(35k)  
to be resisted by vertical walls.

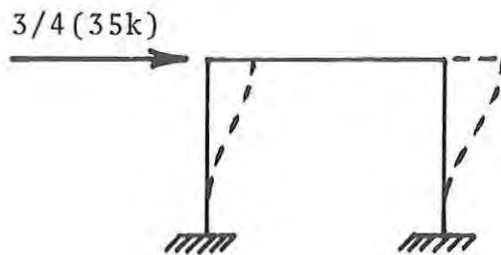

$$\frac{3}{4}(35) = 26.2k$$

$$\text{Moment} = 26.2k(96) = 2.52 \times 10^6 \text{ lb-in}$$

$$\frac{1}{2} \text{ Moment} = 1260,000 \text{ lb-in}$$

$$\sigma = \frac{Mc}{I}$$

Assume resisted by front half of structure.

$$c = .87$$

$$I = [2(12) \frac{t^3}{3} |_{.37}^{.87}] 10$$

$$= 80(.87^3 - .37^3) = (4.86)10$$

$$\sigma = \frac{1260(.87)}{48.6}$$

$$= 22.6 \text{ ksi}$$

$$\therefore \text{ Use } t = .5$$

$$d = 1.75$$

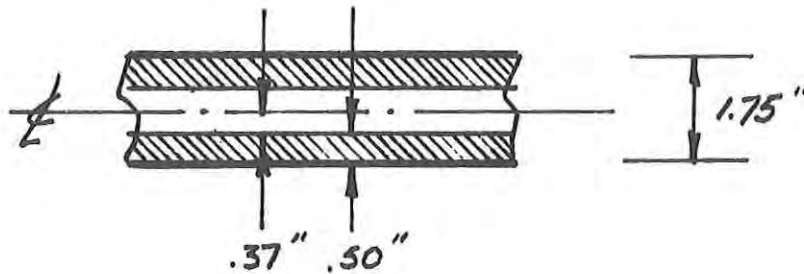

### Injection Molded Materials

#### Urethane Structural Foam

$$\text{Without Ribs } 20' \times 8' \quad y = \frac{1}{2}t$$

$$E_{\text{flex}} = 200,000 \text{ psi}$$

$$y_{\text{max}} = \alpha \frac{wb^4}{Et^3}$$

$$y_{\text{max}} = \frac{1}{2}t$$

$$\frac{1}{2}t = \alpha \frac{wb^4}{Et^3}$$

$$\frac{1}{2}t^4 = \alpha \frac{wb^4}{E}$$

$$t^4 = 2(.12) (.312) (9200)^2 / .2 \times 10^6$$

$$= .24(.312) (84.5) / .2$$

$$= 31.6$$

$$t^2 = 5.61$$

$$t = 2.37 \text{ in}$$

$$\text{Use } t = 2.4 \text{ in}$$

### With Ribs

$$y_{\max} = \alpha \frac{wb^4}{Et^3} \quad x = .12$$

$$y_{\max} = \frac{5}{384} x \frac{wl^4}{EI} \quad I = \frac{bh^3}{12}$$

$$= \frac{16 \times 5}{384 b_1} x \frac{wb^4}{Et^3}$$

$$\frac{16.5}{384 b_1} a = .12$$

$$a = .77$$

$$y_{\max} = .77 \frac{5}{384} \frac{wb^4}{Et^3}$$

$$\text{Try } x = 2.5$$

$$y_{\max} = .77 \frac{5}{384} (.312)(96)^4 / (.2 \times 10^6) I$$

Where  $I = 1.1687$  (from x-section)

$$y_{\max} = .01 (.312)(96)^4 / .2(1.168)$$

$$= .01(113)$$

$$= 1.13''$$

$$\frac{y_{\max}}{t} = \frac{1.13}{2.5} = .45$$

Use  $t = 2.7$  in (to be conservative)

Material savings with ribs

1. High Density Polyethylene & Polypropylene

Without Ribs

$$2.69(6'') = 16.2 \text{ in}^3$$

With Ribs

$$.25(6'') + (3.2 - .25)(.25)$$

$$= 1.5 \text{ in}^3 + 2.95(.25) = 2.24 \text{ in}^3$$

$$\frac{16.2}{2.24} = 7.25 \text{ times as much material}$$

## 2. Urethane

### a. Without Ribs

$$2.4(6'') = 14.4 \text{ in}^3$$

### b. With Ribs

$$.25(6'') + (2.7 - .25)(.25) = 1.5 + 2.45(.25)$$

$$= 2.112 \text{ in}^3$$

$$14.4 / 2.112 = 6.8 \text{ times as much material}$$

## Rotomolding Materials

From Boeing Report

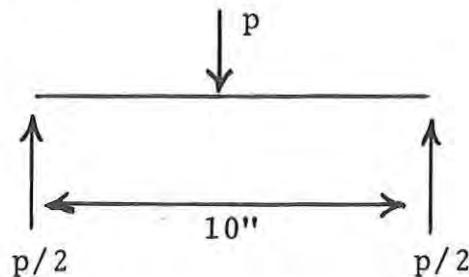

$$P_{\text{yield}} = 950 \text{ lbs without plastic coat}$$

$$= 1150 \text{ lbs with plastic coat}$$

$$\sigma = \frac{Mc}{I} \quad M = \frac{PL}{4}$$

$$\sigma_y = \frac{PL}{4} \frac{C}{I} = \frac{1150(10'')}{4} \frac{6}{bd^2}$$

$$= \frac{1150(10)}{4} \frac{6}{3(\frac{1}{4})^2} = 92,000 \text{ psi}$$

Roof 40 lb/sq ft

$$92,000 = \frac{Mc}{I} \quad M = \frac{wl^2}{8}$$

$$92,000 = \frac{40(96)(96)}{8(12)} \frac{\frac{d}{2}}{\frac{bd^3}{12}}$$

$$\frac{92,000(8)(12)}{40(96)(96)} = \frac{12d}{2bd^2}$$

$$\frac{2(3)d^2}{12} = \frac{40(96)(96)}{(92,000)(8)(12)}$$

$$d^2 = .0835$$

$$d = .29 \text{ in}$$

$$\text{Use } d = .3 \text{ in}$$

### Other Properties Used

	E	G
FRP	$3.5 \times 10^6$	
Aluminum	$10 \times 10^6$	
Steel	$30 \times 10^6$	
High Density Polyethylene	$1.2 \times 10^5$	
Polypropylene	$1.2 \times 10^5$	
Urethane Structural Foam	$2.0 \times 10^5$	
Expanded ABS Skin	$7.68 \times 10^4$	
Polycarbonate Skins	$3.5 \times 10^5$	
Polyurethane Skins	$3.5 \times 10^5$	
Polystyrene Foam		$3.3 \times 10^3$
½" Cell Paper Honeycomb		$10 \times 10^3$
3/16" Cell High Density Al Honeycomb		$50 \times 10^3$
Polyurethane Foam		$1.1 \times 10^3$
Polyethylene Foam		$1.35 \times 10^3$
3/16" Cell Low Density Al Honeycomb		$9.0 \times 10^3$
3/16" Cell Tuf-comb		$17.0 \times 10^3$

Note: E = Modulus of Elasticity  
G = Modulus of Rigidity

All units in lbs/sq in



APPENDIX C

TECHNOLOGY SOURCES



APPENDIX G

Technology Sources

Materials, Suppliers & Processors

A. Centrifugal Casting

1. American Poly-Therm Company  
Sacramento, California
2. Apex Fibre & Glass Products Corporation  
Cleveland, Ohio
3. Corofac Incorporated  
Mantua, Ohio
4. Plastics Development Corporation  
Smyrna, Georgia
5. U. S. Plastic & Chemical Corporation  
W. Havestraw, New York

B. Coated Metals

1. Armco Steel  
Middletown, Ohio
2. Plasticlad  
Cincinnati, Ohio
3. United States Steel Corporation  
Pittsburgh, Pennsylvania

C. Fabrics

1. Clopay Corporation  
Cincinnati, Ohio
2. Darlington Fabric Company  
New York City, New York
3. DuPont de Nemours  
Wilmington, Delaware
4. Herculite Protective  
Newark, New Jersey
5. Uniroyal Inc.  
Mishawaka, Indiana

D. Filament Winding

1. Dana-Whitney Corporation  
Birdsboro, Pennsylvania
2. Justin Enterprises  
Fairfield, Ohio
3. Kaenpen Industries  
Grange, California
4. Stebbins Engineering & Manufacturing Company  
Baton Rouge, Louisiana
5. TRW  
Redondo Beach, California

E. FRP Composites/Building Systems

1. BASF, A.G.  
Ludwigshafen, Germany
2. Farbenfabriken Bayer, A.G.  
Leverkusen, Germany
3. Litewate Transport  
Milwaukee, Wisconsin
4. Lunn Laminates  
Long Island, N. Y.
5. MHI  
Zelienople, Pennsylvania
6. Owens-Corning Fibreglas  
Toledo, Ohio
7. Polystructures, Inc.  
N. Adams, Massachusetts
8. Rudkin-Wiley  
Stanford, Connecticut
9. Tension Structures, Incorporated  
Milan, Michigan

F. Injection-Molding/Structural Foam

1. Art-Fiber Corporation  
New York City, New York
2. Borg-Warner  
Chicago, Illinois

3. Cincinnati Milacron  
Cincinnati, Ohio
4. Dow Chemical  
Midland, Michigan
5. General Electric Company  
Pittsfield, Massachusetts
6. Kadon, Incorporated  
Dayton, Ohio
7. Sund-Borg Machines  
Fremont, Ohio
8. Union Carbide  
New York City, New York
9. Williams-White & Company  
Moline, Illinois

G. Pultrusions

1. Glastrusion, Incorporated  
Torrence, California
2. Koppers Company  
Pittsburgh, Pennsylvania
3. Pultrusions Company  
Kent, Ohio
4. Westinghouse Electric Company  
Pittsburgh, Pennsylvania

H. Rotomolding

1. Artex Industries, Ltd.  
Granby, Quebec, Canada
2. Boeing Company  
Kenton, Washington
3. McNeil-Femco-McNeil  
Cleveland, Ohio

I. Sandwich Panels

1. Douglas Aircraft Corporation  
Santa Monica, California
2. Fome-Core Corporation  
Springfield, Massachusetts

3. Freight Containers Corporation  
Temple City, California
4. G. T. Schjeldahl Company  
Northfield, Minnesota
5. Hexcel Corporation  
LaMiranda, California
6. HITCO  
Gardena, California
7. Honeycomb Corporation of America  
Bridgeport, Connecticut
8. Weyerhaeuser Company  
Tacoma, Washington

J. Shelter Systems

1. Armco Steel Corporation  
Middletown, Ohio
2. Brunswick Corporation  
Marion, Virginia
3. Craig Systems, Corporation  
Lawrence, Massachusetts
4. Department/Housing & Urban Developments  
Washington, D. C.
5. Garrett Corporation  
Los Angeles, California
6. Goodyear Aerospace  
Akron, Ohio
7. M. C. Gill Corporation  
ElMonte, California
8. United States Steel Corporation  
Pittsburgh, Pennsylvania

K. Thermoforming

1. Bakelite-Xylonite, Ltd.  
London, England
2. Hopple Plastics  
Cincinnati, Ohio

3. Philco-Ford  
Fairfield, Iowa
4. Swedlow  
Florence, Kentucky
5. Uniroyal Plastics Products  
Warsaw, Indiana

