

AD-A037 410

AMPEX CORP REDWOOD CITY CALIF
STUDY, TESTS, AND EVALUATION FOR
JAN 77 C F SPITZER, T A JENSEN, J M UTSCHIG
EP-7356

WIDEBAND HIGH-DENSITY DATA ACQ--ETC(U)
F33615-75-C-1192
AFAL-TR-76-115
NL

F/G 14/3

UNCLASSIFIED

1 OF 2
AD
A037410

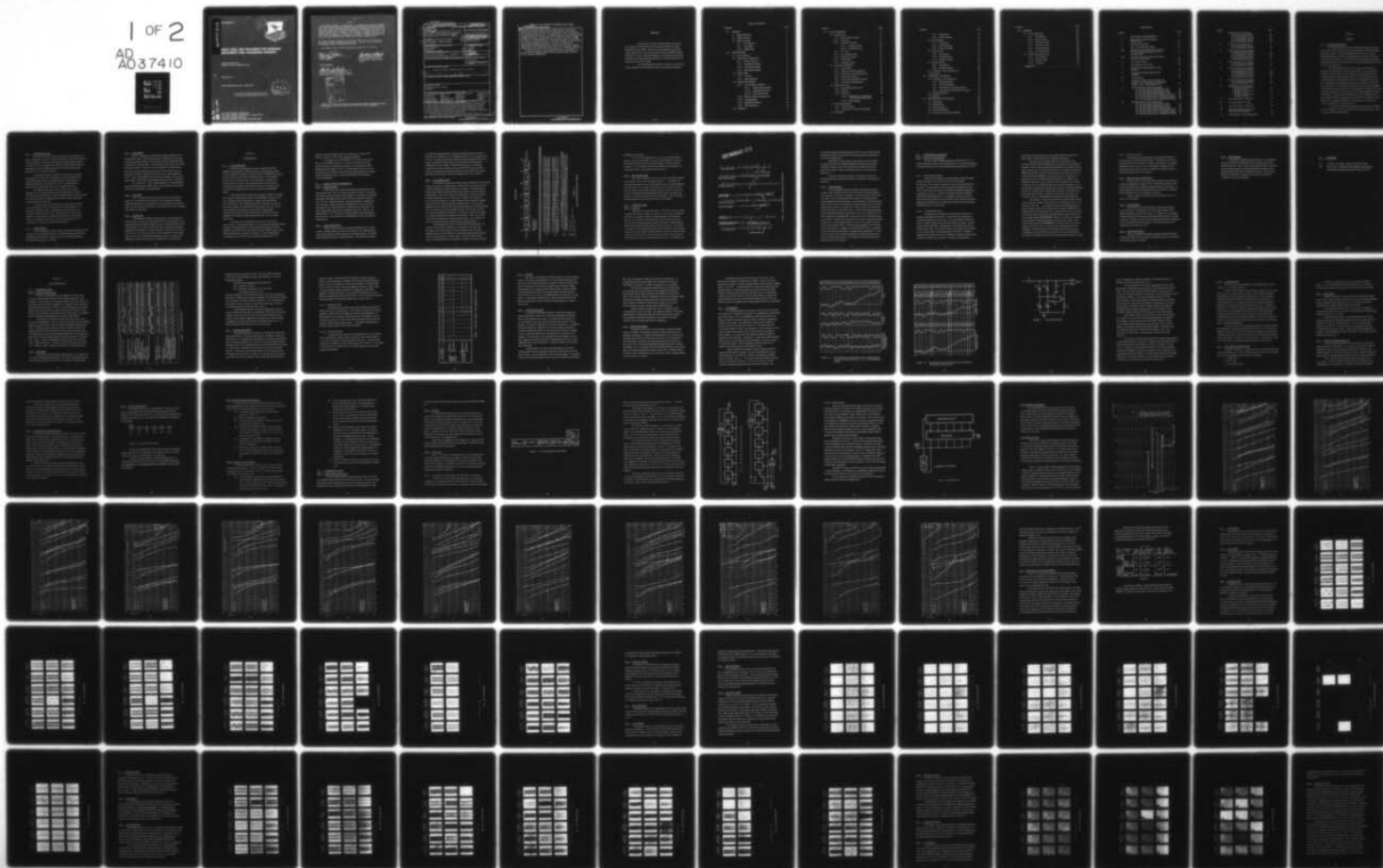

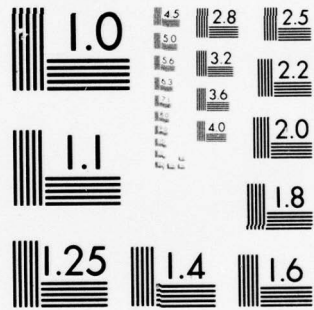

MICROCOPY RESOLUTION TEST CHART
NATIONAL BUREAU OF STANDARDS-1963-A

ADA 037410

AFAL-TR-76-115 ✓

12



STUDY, TESTS, AND EVALUATION FOR WIDEBAND HIGH-DENSITY DATA ACQUISITION (WHIDDA)

AMPEX CORPORATION
REDWOOD CITY, CALIFORNIA 94063

JANUARY 1977

FINAL REPORT APRIL 1975 - MARCH 1976

DDC
RECEIVED
MAR 28 1977
A

Approved for public release; distribution unlimited

HU RW.
DDC FILE COPY.

AIR FORCE AVIONICS LABORATORY
AIR FORCE WRIGHT AERONAUTICAL LABORATORIES
AIR FORCE SYSTEMS COMMAND
WRIGHT-PATTERSON AIR FORCE BASE, OHIO 45433

NOTICE

When Government drawings, specifications, or other data are used for any purpose other than in connection with a definitely related Government procurement operation, the United States Government thereby incurs no responsibility nor any obligation whatsoever; and the fact that the government may have formulated, furnished, or in any way supplied the said drawings, specifications, or other data, is not to be regarded by implication or otherwise as in any manner licensing the holder or any other person or corporation, or conveying any rights or permission to manufacture, use, or sell any patented invention that may in any way be related thereto.

This report has been reviewed by the Information Office (OI) and is releasable to the National Technical Information Service (NTIS). At NTIS, it will be available to the general public, including foreign nations.

This technical report has been reviewed and is approved for publication.

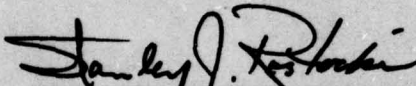
STANLEY J. ROSTOCKI
Project Engineer

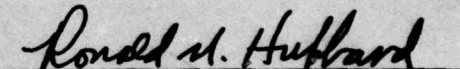
RONALD N. HUBBARD, Actg Chief
Reconnaissance Systems Group
Electro-Optics & Reconnaissance
Branch

FOR THE COMMANDER

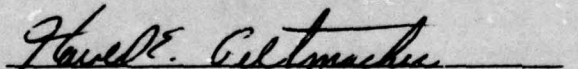
HAROLD E. GELTMACHER, Acting Chief
Electro-Optics and Reconnaissance Branch
Reconnaissance and Weapon Delivery Division

ACCESSION for	
NTIS	White Section <input checked="" type="checkbox"/>
BDC	Blue Section <input type="checkbox"/>
UNANNOUNCED	
JUSTIFICATION	
BY	
DISSEMINATION/AVAILABILITY CODES	
Dist.	AVAIL. STATE SYMBOL
A	

Copies of this report should not be returned unless return is required by security considerations, contractual obligations, or notice on a specific document.

UNCLASSIFIED

SECURITY CLASSIFICATION OF THIS PAGE (When Data Entered)

19 REPORT DOCUMENTATION PAGE		READ INSTRUCTIONS BEFORE COMPLETING FORM
18 1. REPORT NUMBER AFAL TR-76-115	2. GOVT ACCESSION NO.	3. RECIPIENT'S CATALOG NUMBER
6 4. TITLE (and Subtitle) STUDY, TESTS, AND EVALUATION FOR WIDEBAND HIGH-DENSITY DATA ACQUISITION (WHIDDA)	5. TYPE OF REPORT & PERIOD COVERED Final. April 1975 - March 1976	
7. AUTHOR(s) Charles F. Spitzer, Theodore A. Jensen, John M. Utschig	14 PERFORMING ORG. REPORT NUMBER Prop. No. 9433-4047 EP-7356	8. CONTRACT OR GRANT NUMBER(s) F33615-75-C-1192
9. PERFORMING ORGANIZATION NAME AND ADDRESS Ampex Corporation 401 Broadway Redwood City, CA 94063	10. PROGRAM ELEMENT, PROJECT, TASK AREA & WORK UNIT NUMBERS 665A-03-36	
11. CONTROLLING OFFICE NAME AND ADDRESS Air Force Avionics Laboratory Wright-Patterson AFB, Ohio 45433	12. REPORT DATE January 1977	13. NUMBER OF PAGES 122
14. MONITORING AGENCY NAME & ADDRESS (if different from Controlling Office)	15. SECURITY CLASS. (of this report) UNCLASSIFIED	15a. DECLASSIFICATION/DOWNGRADING SCHEDULE
16. DISTRIBUTION STATEMENT (of this Report) Approved for public release; distribution unlimited.		
9 Final technical rpt. Apr 75 - Mar 76		
17. DISTRIBUTION STATEMENT (of the abstract entered in Block 20, if different from Report)		
18. SUPPLEMENTARY NOTES Monitored by Stanley J. Rostocki AFAL/RWI-1 7.E63208F		
19. KEY WORDS (Continue on reverse side if necessary and identify by block number) Bit-Packing Density Enhanced NRZ Magnetic Tape Recorders Pattern Sensitivity Recorders Bit-Error Rate HDDR Miller Code Recording Code Code Selection High Bit Rate Modified NRZ Wideband Delay Modulation High-Density Digital M ² - Code WHIDDA Digital Recording Magnetic Tape Narrow Band Phasing Encoding		
20. ABSTRACT (Continue on reverse side if necessary and identify by block number) The forceful trend toward recording wideband analog signals on high-density digital recorders requires the most careful assessment of the limiting parameters of this process. It has been established that the bit-error rate of the reproduced digital signal is often critically dependent on the pattern sensitivity of the chosen recording code. Since the digitized analog signals usually exhibit strong data patterning, such pattern sensitivity may have devastating effects on the bit-error rate of the system. The broad and basic objective of this program was the impartial assessment and		

over mt

DD Form 1473: Report Documentation Page
UNCLASSIFIED

SECURITY CLASSIFICATION OF THIS PAGE(When Data Entered)

comparison of the Miller code (also known as delay modulation code) and the Modified NRZ code (with insertion of the inverted seventh bit as an eighth bit), for bit packing densities of 10, 20, 30, 40, and 50 Kb/in., each case being tested with pseudorandom words of 63, 511, and 1023 bits and with 6-bit words representing a sampled ramp function, and repeated 32, 64, and 128 times, respectively. To this objective we added evaluation of a code developed at Ampex concurrent with this program, and named the "M²-code." The basis of comparison was the bit-error rate, for stepwise degradation of signal-to-noise ratio to simulate typical deterioration of recorder performance due to poor recorder maintenance, low tape response (either due to unsatisfactory initial quality, wear or dropouts), differences in head response (from track to track or after replacement of a head assembly), etc.

A secondary objective was the documentation by means of oscillograms of the "eye" patterns, waveforms, zero-line drift, and spectral content, for most of the test conditions described above.

UNCLASSIFIED

SECURITY CLASSIFICATION OF THIS PAGE(When Data Entered)

FOREWORD

This document is the Final Technical Report under Contract No. F 33615-75-C-1192 with the Air Force Avionics Laboratory, Wright-Patterson AFB, Ohio 45433. The report covers the period of 1 April 1975 through 1 March 1976. The work was performed under the technical direction of Theodore A. Jensen, Senior Staff Engineer in the Tape Systems Engineering Department of the Ampex Data Products Division, and the experimental work was executed by John M. Utschig.

Our sincere thanks go to Stanley J. Rostocki of the Air Force Avionics Laboratory for his consistent interest and guidance of this program.

TABLE OF CONTENTS

SECTION	PAGE
1.0 SUMMARY	1
1.1 Program Objectives	2
1.2 Significant Results	1
1.3 Major Conclusions	2
1.3.1 Code Selection	2
1.3.2 Test Method	3
1.3.3 Standard Tape	3
2.0 INTRODUCTION	5
2.1 Basic Objectives	5
2.2 Typical System Configuration	6
2.2.1 General Comments	6
2.2.2 Longitudinal Recorders	6
2.2.3 Data Handling System	7
2.2.4 Basic Recorder Design	9
2.3 Program Scope	9
2.3.1 Overview	9
2.3.2 Code Comparisons	11
2.4 Experimental Limitations	12
2.4.1 Tests for Pattern Sensitivity	12
2.4.1.1 Pseudo-random Numbers	12
2.4.1.2 Sampled Ramp Function	12
2.4.1.3 Other Test Functions	14
2.4.2 BER as a Function of Record Level	14
2.4.3 Pre-Equalization	14
2.4.4 Bandwidth Limitations	14
2.4.5 BER Measurements	15
2.5 References	17

SECTION	PAGE
3.0 CODE COMPARISONS	19
3.1 Recording Codes	19
3.1.1 Need for Code Conversion	19
3.1.2 Miller Code	19
3.1.3 Modified NRZ (MNRZ)	21
3.1.3.1 Odd-Parity MNRZ	22
3.1.3.2 Inverted-Bit MNRZ	23
3.1.4 M^2 - Code	24
3.1.5 Other Recording Codes	24
3.1.6 Digital-Sum Variation	25
3.1.7 DC-Restoration	26
3.1.8 DC-Restorer Circuit	31
3.2 Test Method and Procedure	31
3.2.1 Record Margin	32
3.2.2 Validity of the Record Margin Test	32
3.2.3 Interpretation of Record Margin Tests	32
3.2.4 Detailed Test Procedure	34
3.2.5 Step-by-Step Optimization Procedure	35
3.2.6 Limitations and Inconsistencies	35
3.3 Experimental Set-Up	36
3.3.1 Tape Transport and Electronics	36
3.3.2 Test Tape	37
3.3.3 Test Circuit	37
3.3.3.1 Datapulse 213 A Pseudo-Random Word Generator and Comparator	37
3.3.3.2 Ramp Generator	41
3.4 Bit Error Measurements	43
3.4.1 Pattern Sensitivity	43
3.4.2 Optimization for Zero DB Record Margin	57
3.5 Eye Patterns	59

SECTION	PAGE
3.5.1	Test Procedure 59
3.5.2	General Comments 59
3.6	Bit Waveshapes 67
3.6.1	Test Procedure 67
3.6.2	General Comments 68
3.6.3	Discussion of Results 68
3.7	Zero-Line Drift 76
3.7.1	Test Procedure 76
3.7.2	General Comments 76
3.7.3	Discussion of Results 84
3.8	Spectral Densities 84
3.8.1	Test Procedure 84
3.8.2	Discussion of Results 88
3.9	Conclusion of Code Comparison Tests 89
3.10	References 93
4.0	INTERSYMBOL INTERFERENCE 95
4.1	Pre-emphasis vs Post-equalization 95
4.1.1	Problem Description 95
4.1.2	Anti Pulse-Crowding 96
4.1.3	Peak Detection in Computer Transports 96
4.1.4	High Bit-Densities: Behr-Blessum Technique 97
4.2	Computer Simulation 99
4.3	References 101
5.0	RECOMMENDED FUTURE RESEARCH 103
5.1	Code Studies 103
5.2	Standardization 103
5.3	Head Development 104
5.4	Equalizer Development 104
5.5	Error Detection and Correction (EDAC) 104

SECTION	PAGE
6.0 APPENDIX	107
6.1 Sources of Bit-Errors	107
6.1.1 Tape Dropouts	107
6.1.2 Zero-Line Drift	107
6.1.3 DC-Restorer Effects	108
6.1.4 Loss of Sync Word	108
6.1.5 Simultaneous Bursts	108
6.1.6 Loss of Frame Sync	108
6.2 Comments on Tape Selection	109
6.2.1 Series 797 Tape	109
6.2.2 Series 799 Tape	110
6.2.3 Conclusion	110
REFERENCES	111

ILLUSTRATIONS

FIGURE		PAGE
1	Data Handling and Timing Diagram	8
2	Design Chart for Space Multiplexed PCM Recording	10
3	Digital Recording Codes	20
4	Worst - Case Patterns for MNRZ	23
5(a)	Bit Patterns and Their Digital-Sum Variations for the Data Input Code (NRZ-L) and two Recording Codes	27
5(b)	Bit Patterns and Their Digital-Sum Variations for the two MNRZ codes.	28
6	DC - Restorer Circuit	29
7	Block Diagram of Test Circuit	38
8	Datapulse 213 A Pseudo-Random Number Generator	40
9	Datapulse 213 A Pseudo-Random Number Comparator	40
10	Ramp Generator	42
11	Dependence of BER on Initial Conditions, for Inverted - Bit MNRZ Tested by 511-Bit Pseudo-Random Number. (Tape Speed: 60 in/s)	44
12	BER Measurements at 30 in/s Tape Speed	
	(a) Test Word: 63-bit Pseudo-Random Number	45
	(b) Test Word: 511-bit Pseudo-Random Number	46
	(c) Test Word: 1023-bit Pseudo-Random Number	47
	(d) Test Word: Ramp Function, 32 Repetitions/Sample	48
	(e) Test Word: Ramp Function, 64 Repetitions/Sample	49
	(f) Test Word: Ramp Function, 128 Repetitions/Sample	50
13	BER Measurements at 60 in/s Tape Speed	
	(a) Test Word: 63-bit Pseudo-Random Number	51
	(b) Test Word: 511-bit Pseudo-Random Number	52
	(c) Test Word: 1023-bit Pseudo-Random Number	53
	(d) Test Word: Ramp Function, 32 Repetitions/Sample	54
	(e) Test Word: Ramp Function, 64 Repetitions/Sample	55
	(f) Test Word: Ramp Function, 128 Repetitions/Sample	56

FIGURE		PAGE
14	Eye Patterns at 30 in/s Tape Speed	
	(a) Bit Packing Density: 10 Kb/in	60
	(b) Bit Packing Density: 20 Kb/in	61
	(c) Bit Packing Density: 30 Kb/in	62
	(d) Bit Packing Density: 40 Kb/in	63
	(e) Bit Packing Density: 50 Kb/in	64
15	Eye Patterns at 60 in/s Tape Speed	
	(a) Bit Packing Density: 40 Kb/in	65
	(b) Bit Packing Density: 50 Kb/in	66
16	Bit Wave Shapes at 30 in/s Tape Speed	
	(a) Bit Packing Density: 10 Kb/in	69
	(b) Bit Packing Density: 20 Kb/in	70
	(c) Bit Packing Density: 30 Kb/in	71
	(d) Bit Packing Density: 40 Kb/in	72
	(e) Bit Packing Density: 50 Kb/in	73
17	Bit Wave Shapes at 60 in/s Tape Speed	
	(a) Bit Packing Density: 40 Kb/in	74
	(b) Bit Packing Density: 50 Kb/in	75
18	Zero-Line Drift at 30 in/s Tape Speed	
	(a) Bit Packing Density: 10 Kb/in	77
	(b) Bit Packing Density: 20 Kb/in	78
	(c) Bit Packing Density: 30 Kb/in	79
	(d) Bit Packing Density: 40 Kb/in	80
	(e) Bit Packing Density: 50 Kb/in	81
19	Zero-Line Drift at 60 in/s Tape Speed	
	(a) Bit Packing Density: 40 Kb/in	82
	(b) Bit Packing Density: 50 Kb/in	83
20	Spectrograms at 30 in/s Tape Speed	
	(a) Bit Packing Density: 30 Kb/in (Bit Rate = 0.9 Mb/s)	85
	(b) Bit Packing Density: 40 Kb/in (Bit Rate = 1.2 Mb/s)	86
	(c) Bit Packing Density: 50 Kb/in (Bit Rate = 1.5 Mb/s)	87
21	Test Word Comparison - Miller Code	90
22	Test Word Comparison - M^2 Code	91
23	Test Word Comparison - MNRZ Code	92
24	Record and Reproduce Wave forms for a Typical Computer Tape Recorder	98
25	Typical Computer - Calculated Eye Pattern	98

SECTION 1

SUMMARY

1.1 PROGRAM OBJECTIVES

The forceful trend toward recording wideband analog signals on high-density digital recorders requires the most careful assessment of the limiting parameters of this process. It has been established that the bit-error rate of the reproduced digital signal is often critically dependent on the pattern sensitivity of the chosen recording code. Since the digitized analog signals usually exhibit strong data patterning, such pattern sensitivity may have devastating effects on the bit-error rate of the system.

The broad and basic objective of this program was the impartial assessment and comparison of the Miller code (also known as delay modulation code) and a Modified NRZ code (with insertion of the inverted seventh bit as an eighth bit), for bit packing densities of 10, 20, 30, 40 and 50 Kb/in, each case being tested with pseudo-random words of 63, 511 and 1023 bits; and with 6-bit words representing a sampled ramp function, and repeated 32, 64 and 128 times, respectively. To this objective we added evaluation of a code developed at another Ampex division concurrent with this program, and named the "M² - code". The basis of comparison was the bit-error rate, for stepwise degradation of signal-to-noise ratio to simulate typical deterioration of recorder performance due to poor recorder maintenance, low tape response (either due to unsatisfactory initial quality, wear or dropouts), differences in head response (from track to track, or after a replacement of a head assembly), etc.

A secondary objective was the documentation by means of oscillograms of the "eye" patterns, waveforms, zero-line drift, and spectral content, for most of the test conditions described above.

1.2 SIGNIFICANT RESULTS

We believe to have met all of the major objectives established at the outset. Throughout the program we made every attempt to conduct the experiments with total objectivity, but there always remains the question whether changes or variations from known implementations might have produced other results. For these reasons we offer the following summary of our results as being strongly indicative, but not necessarily conclusive.

At bit-packing densities up to 30 Kb/in, and the use of a pseudo-random number as the test word, the differences in bit-error performance are not significant and are within experimental error, for the three codes. At packing densities of 30, 40 and 50 Kb/in, the M^2 - code performs best, followed by the standard Miller Code next, and Modified NRZ last.

If a digitized ramp function is used as the test word, bit-error performance at any bit-packing density between 10 and 50 Kb/in is best for M^2 , next-best for standard Miller, and last for Modified NRZ. We find, however, that a system optimized to the digitized ramp function is then also optimized to the pseudo-random number test.

Extensive experimental documentation of these statements is found in the bit-error graphs of Figs. 12(a) through (f) and 13(a) through (f), the eye pattern oscillograms of Figs. 14(a) through (e) and 15(a) and (b), and the zero-line drift oscillograms of Figs. 18(a) through (e) and 19(a) and (b). Additional understandings for the different results of use of a pseudo-random number, or a digitized ramp function, as a test word can be derived from examination of the spectrograms of Figs. 20(a) through (c).

1.3 CONCLUSIONS

From the experiments to date we derive the following conclusions, which we believe to be of substantial impact on the orderly advancement of the art of High Bit-Rate (HBR) recording in general, and for the optimized performance of future Air Force programs in particular.

1.3.1 Code Selection

The M^2 - code appears to offer the best long-term potential as the standard code for HBR. It offers the best bit-error performance over the widest range of bit-packing densities, and is at least equal (within experimental error) in performance to standard Miller - code and Modified NRZ under even the least demanding conditions. Moreover, it can be demonstrated that there exists a significant degree of compatibility between the M^2 and the Miller code; i.e. tapes can be recorded, or reproduced in Miller code on a system designed for the M^2 - code, with negligible increase in circuit complexity. Thus, existing tapes recorded in Miller code can be reproduced on any such M^2 - code system.

The use of the M^2 - code is further suggested by the high probability that the conventional pseudo-random number is not a suitable test word for data derived from analog signals as mentioned above.

1.3.2 Test Method

Since the pseudo-random number test fails to examine for pattern sensitivity, we recommend that such future Air Force systems as are based on digitized analog signals, be evaluated with a test word derived from a digitized ramp, with each word repeated 128 times. Instrumentation for this test is comparatively simple and inexpensive.

1.3.3 Standard Tape

Standardization activities should be initiated, toward generation of reference tapes, by means of which a given HBR system can be examined. Such tapes should contain recordings in IRIG format, and at standardized levels for the following signals: M^2 , Miller and Modified NRZ, at signal packing densities ranging from 10 to 50 Kb/in, in 10 Kb/in steps and at bit rates of 0.1, 0.2, 0.5, 0.8, 1.0, 2.0, 3.0, 4.0, and 5.0 Mb/s. The data recorded on such test tapes might cover 63-, 511- and 1023-bit pseudo-random numbers, as well as words derived from a digitized ramp function and repeated 32, 64, and 128 times.

SECTION 2

INTRODUCTION

2.1 BASIC OBJECTIVES

The digital record/reproduce equipment currently used for the SAPPHIRE system consists of an airborne recorder and matching ground-based reproducer capable of recording at a lineal bit density of 20,000 bits/inch/track at rates varying continuously from 516,000 bits/second to 1.536 megabits/second on each of 25 data channels. The tape transport is servoed to the incoming data rate to achieve constant packing density at all bit rates and the ground based reproducer contains deskew electronics to re-align the data on all tracks. Far higher data rates will be required for future SAPPHIRE systems.

Wideband high-density digital data acquisition (WHIDDA) on magnetic tape represents a requirement not only for future SAPPHIRE recorders, but also for an increasing number of applications in weapons systems and satellite communication links. The combined specifications of high data rate and long record time, together with the desire for lowest possible system cost, minimum system complexity and maintenance, and preferably compact design, necessitate the increase of areal bit-packing densities (bits/inch²) through increases in both lineal bit packing densities (bits/inch) and track densities (tracks/inch).

Data acquisition at 80 megabits/second is easily within today's state-of-the-art. The UPD-X development will require airborne acquisition systems operating at 250 megabits/second, with ground-based equipment of matching capability. Other systems now under design will require WHIDDA rates in excess of 300 megabits/second. In nearly all instances, bit error rates (BER's) may not exceed one error in 10^5 bits; some systems demand BER's below 10^{-7} ,

whereas a very few (probably pictorial) types of systems can tolerate 10^{-4} . Typically, a BER of 5×10^{-6} is often considered acceptable.

In most applications, the WHIDDA device is critical to the system. Not only is its reliability paramount, but minimum maintenance and long record time between reel changes are mandatory, even at data rates of 250 megabits/second with BER of 5×10^{-6} . The basic objective of the work under this contract was an extension of theoretical and practical experience as a significant step towards these goals, and to provide direction for future designs of Air Force equipment.

2.2 TYPICAL SYSTEM CONFIGURATION

2.2.1 General Comments

As stated above, the combined requirements of high digital bit rates and long record times without reel change, necessitate increases in track density and bit density, beyond the present state-of-the-art. For example, uninterrupted acquisition of 250 megabits/second data for 30 minutes requires the storage of 4.5×10^{11} bits. Airborne equipment is typically designed for a maximum reel-size of 14 inches, and hence a capacity of 9,000 feet of one-inch wide tape (at a standard 1.0 mil base thickness and a 200-foot leader at each end). The required areal density is thus about 4.0 megabits/square inch. However, the specified BER of 5×10^{-6} currently limits areal densities to about 0.8 megabit/square inch (e.g., at a lineal density of 33,000 bits/inch and a track density of 25 tracks/inch).

2.2.2 Longitudinal Recorders

High bit-rate data streams can be space-multiplexed onto a number of tracks, recorded, deskewed, and then demultiplexed. This method efficiently utilizes the simultaneous recording feature of a multichannel system. One means of accomplishing this objective is described below. Within existing technology

we consider 250 megabits/second recording and reproducing rates to be current state-of-the-art, and rates of 1.5 to 2 gigabits/second may well be feasible within five years. Such rates are predicated either upon wider tape (perhaps three or four inches), track densities of 42 tracks/inch, and lineal bit packing densities of 40,000 bits/inch or even higher. Within these parameters, we may hope for record times of at least ten minutes, and error rates of 10^6 bits/error or better. A system of these specifications should weigh no more than 100 pounds, consume about 500 watts and occupy no more than perhaps four cubic feet in volume.

2.2.3 Data Handling System

If the bit-rate of a given input data channel is higher than can be recorded with good error-rate on a single track (i.e. 5 Mb/s maximum), then the bit stream is space-multiplexed over several channels; for example, the 15 Mb/s stream of a data channel might be divided over three input channels, as shown in Figure 1. In this example, a sync word is repetitively generated on a fourth input channel, (in practical equipment, we now use one such "overhead" input channel, for every 13 data input channels, i.e. about 8 percent of the recording is "overhead" and the 16-bit sync words are separated by 240 data bits). In the Sync Word Distributor the sync word and a data word exchange locations so that each recorded track will contain a sync word at periodic intervals (in this example, the 4-bit sync words are separated by 12 data bits). The NRZ input code is now converted to a suitable recording code in preparation to recording. In Part 3.0, we shall say more about the selection of a suitable recording code. The recording code must be such as to permit clock recovery from the reproduced signal.

Following playback, the bits are detected and the clock signal is extracted. Next, the data are decoded, i.e. reconverted to the NRZ code. The signals recovered from the four tracks are reproduced with various time displacements due to minor differences in record gap-to-reproduce gap distances, "skew" of the moving tape, and other reasons. The Track Alignment Logic removes these displacements and reestablishes the alignment of the data existing

DATA HANDLING DIAGRAM

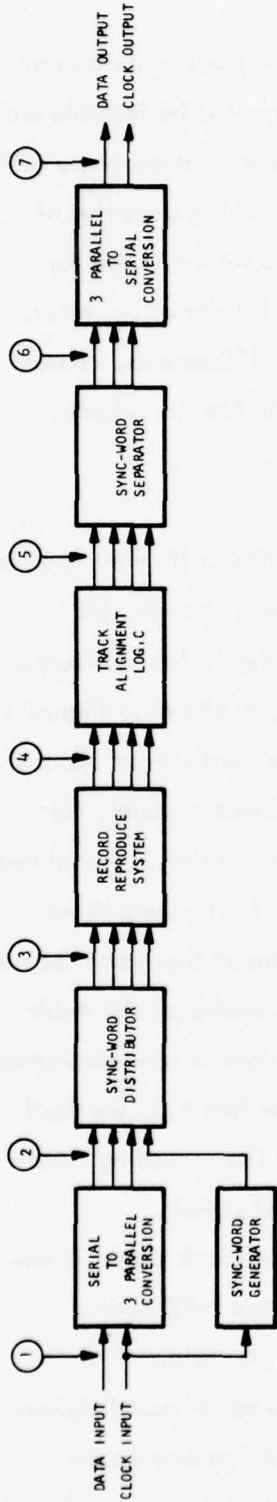

1	2	3	4	5	6	7	8	9	10	11	12	13	14	15	16	17	18	19	20	21	22	23	24	25	26	27	28	29	30	31	32	33	34	35	36	37	38	39	40	41	42	43	44	45	46	47	48	49	50	51	52	53	54	55	56	57	58	59	60	61	62	63	64	65	66	67	68	69	70	71	72	73	74	75
---	---	---	---	---	---	---	---	---	----	----	----	----	----	----	----	----	----	----	----	----	----	----	----	----	----	----	----	----	----	----	----	----	----	----	----	----	----	----	----	----	----	----	----	----	----	----	----	----	----	----	----	----	----	----	----	----	----	----	----	----	----	----	----	----	----	----	----	----	----	----	----	----	----	----

1	4	7	10	13	16	19	22	25	28	31	34	37	40	43	46	49	52	55	58	61	64	67	70
2	5	8	11	14	17	20	23	26	29	32	35	38	41	44	47	50	53	56	59	62	65	68	71
3	6	9	12	15	18	21	24	27	30	33	36	39	42	45	48	51	54	57	60	63	66	69	72
SI	S2	S3	S4	SI	S2	S3	S4	SI	S2	S3	S4	SI	S2	S3	S4	SI	S2	S3	S4	SI	S2	S3	S4

1	4	7	10	SI	S2	S3	S4	25	28	31	34	37	40	43	46	49	52	55	58	SI	S2	S3	S4
2	5	8	11	14	17	20	23	SI	S2	S3	S4	38	41	44	47	50	53	56	59	62	65	68	71
3	6	9	12	15	18	21	24	27	30	33	36	39	42	45	48	51	54	57	60	63	66	67	72
SI	S2	S3	S4	SI	S2	S3	S4	SI	S2	S3	S4	SI	S2	S3	S4	SI	S2	S3	S4	SI	S2	S3	S4

1	4	7	10	SI	S2	S3	S4	25	28	31	34	37	40	43	46	49	52	55	58	SI	S2	S3	S4
2	5	8	11	14	17	20	23	SI	S2	S3	S4	38	41	44	47	50	53	56	59	62	65	68	71
3	6	9	12	15	18	21	24	27	30	33	36	39	42	45	48	51	54	57	60	63	66	64	72
SI	S2	S3	S4	SI	S2	S3	S4	SI	S2	S3	S4	SI	S2	S3	S4	SI	S2	S3	S4	SI	S2	S3	S4

REF

4	1	2	3	4	5	6	7	8	9	10	11	12	13	14	15	16	17	18	19	20	21	22	23	24	25	26	27	28	29	30	31	32	33	34	35	36	37	38	39	40	41	42	43	44	45	46	47	48	49	50	51	52	53	54	55	56	57	58	59	60	61	62	63	64	65	66	67	68	69	70	71	72
---	---	---	---	---	---	---	---	---	---	----	----	----	----	----	----	----	----	----	----	----	----	----	----	----	----	----	----	----	----	----	----	----	----	----	----	----	----	----	----	----	----	----	----	----	----	----	----	----	----	----	----	----	----	----	----	----	----	----	----	----	----	----	----	----	----	----	----	----	----	----	----	----

5 EQUALS 3, PLUS DELAY

6 EQUALS FIRST THREE LINES OF 2, PLUS DELAY

7 EQUALS 1, PLUS DELAY

FIGURE 1

DATA HANDLING AND TIMING DIAGRAM

preceding their recording.

In the Sync Word Separator, the sync word and its matching data word are once more interchanged, and the sync word discarded. The data now have the same format and code as they had subsequent to serial-to-parallel conversion. In the final step, the three output channels are recombined into a single data stream, by the parallel-to-serial converter.

2.2.4 Basic Recorder Design

The number of channels, record time, reel size, and other parameters can be selected with use of the nomograph of Figure 2. The broken line illustrates the example of using a 16-inch diameter reel, on a recorder operating on 39 data tracks, at a bit density of 25 Kb/in, (this will require 3 overhead tracks for present Ampex designs), 200 Mb/s serial bit rate for the system (this rate may be composed of 8 data channels of 25 Mb/s each, for example) and allowing 14.2 minutes record time at 180 in/s tape speed. Trade-offs between recorder parameters can be readily derived from this nomograph.

2.3 PROGRAM SCOPE

2.3.1 Overview

Higher bit rate, longer record time, or better BER, will require either increased lineal density, or higher track density, or wider tape to accommodate more tracks. A suitable combination of these approaches will be desirable. However, in the interest of system simplicity, lowest initial and life-cycle cost, and least maintenance, repair and spares requirements, lineal bit packing density should be optimized first, before invoking an increase in track density, or yet departing from the standard one-inch tape configuration to allow for more tracks at lower track densities: The least number of tracks with associated signal electronics will surely result in the lowest cost of ownership of the equipment, and minimize the maintenance manhours per operating hour. Accordingly, and

in the interest of good value-engineering practice, this contract has specifically addressed the problem of optimized lineal bit-packing density, through choice of a suitable recording code.

The objectives of this contract were the study, test and evaluation of bit packing densities for Wideband High-density Digital Data Acquisition (WHIDDA) on magnetic tape, with the specific goal of advancing airborne digital data recording to rates of 250 megabits/second for side looking radar applications.

The scope of the effort consisted of code studies, evaluation of band-pass adjustment methods and experimental verifications of the studies and evaluations.

2.3.2 Code Comparisons

Since the reproduce head of the magnetic tape recorder generates a signal in direct proportion to the time rate-of-change of the flux recorded on the moving tape, the recorder is incapable of reproducing the DC content of the input signal. Even the requirement of good response at low frequencies may seriously degrade error-rate performance. As a consequence, the usual NRZ input code must be converted to a comparatively DC-free recording code with the least possible energy content at low frequencies. The most commonly used recording codes are the Miller code described in Ref. 2.1 (also known as Delay Modulation, Narrow-band Phase Modulation, Modified FM, etc.), and a modification of the NRZ-L code known as Enhanced NRZ in which a parity bit is inserted after every seven data bits, such that the total number of ones is odd, for each group of eight bits (Ref. 2.2). For the reasons stated in 3.1.3.2, we have chosen to examine another form of Modified NRZ, in which the inserted eighth bit is the inversion of the seventh data bit. In addition, we have tested the M^2 -code, a proprietary DC-free recording code developed by the Ampex Research Department. In each case the test track of the recorder was amplitude- and phase-equalized for the specific recording code under test. The methods used and results obtained are detailed in Part 3.0 of this report.

2.4 EXPERIMENTAL LIMITATIONS

2.4.1 Tests for Pattern Sensitivity

Since the number of possible data pattern has no finite limit, it is patently impossible to perform a fully exhaustive test. The two basic test patterns we explored were chosen for the reasons described below (see also Para 3.3.3).

2.4.1.1 Pseudo-random Numbers

Generators and comparators for pseudo-random numbers are readily available instruments, which can be set for varying word lengths. For this reason, this test pattern is probably the most commonly specified one, at present. We chose lengths of 63 bits (representing a comparatively short word), 511 bits (as the most commonly used length) and 1023 bits (representing a reasonably long word). We believe that these three lengths adequately bracket the most interesting range. It is possible, of course, that there are certain other critical lengths yet to be discovered, which might be particularly dangerous to the BER for any one recording code, similar to the 63 and 511 bits for MNRZ (see Para 3.1.3 and 3.3.3).

2.4.1.2 Sampled Ramp Function

Test equipment for this pattern was specially constructed for the sequence of experiments in this report. The ramp function is generated by successively augmenting a 6-bit counter. Thus, each "sample" contained 64 levels. Provision is made to repeat each such sample many times. We chose 32; 64; and 128 repetitiously, corresponding to word lengths of 192; 384; and 768 bits, respectively. The sequence of patterns then repeats after presentation of 64 successive samples, each repeated 32; 64; or 128 times. Experience suggests that this test is quite severe, and effectively discloses insipient pattern sensitivity of the BER for a given code. In addition, the reconstructed

(D/A)-converted) ramp function provides a highly interpretive display of the effect of BER, if the source signal was a digitized analog signal.

The reason why the sampled-ramp function test tends to reveal pattern sensitivity of a given recording code can be deduced from the following discussion. The 6-bit counter systematically generates all 64 possible combinations of ones and zeros, of which the 6-bit words can be composed, starting with 000000 and terminating with 111111 (which signals the end of the ramp cycle, and resets the generator to 000000, i.e. causes start of the next ramp cycle). For example, the worst-case condition for the Miller-code, i.e. 101101, is also generated in due course. Now, if each 6-bit word is repeated a given number of times (i.e. 32, 64, or 128 times) before the next word is generated, we can be reasonably assured that the worst-case data word has been presented sufficiently often to test the ability of the recording code to maintain specified BER in the face of such severe conditions. Indeed, even if the worst-case pattern were not known a-priori, it would probably be revealed by the ramp-function test.

For example, it is known that the odd-parity Modified NRZ code may suffer a worst-case condition of 14 successive ones, as discussed in Para. 3.1.3.1 and shown in Fig. 4(a). In an attempt to break up the deleterious effect of a long run of ones (or zeros) in the worst-case data word (e.g. 01111111111111), one might selectively invert certain bits, e.g. the second, third, sixth, and seventh bit of every seven-bit sequence, thus changing the above worst-case word into a more benign sequence (00011001001100). However, in so doing we would only have succeeded in replacing the original worst-case word by another: If the original data word had been 00011001001100, inversion of these bits would now restore the 14-bit run of ones. A seven-bit ramp would probably prove more damaging to the BER for data patterns in Modified NRZ, than a 6-bit ramp. Nevertheless, we have found the ramp function test with up to 128 repetitions per sample to be sufficiently incisive for the code comparison experiments to date.

2.4.1.3 Other Test Functions

Quite possibly other data patterns could be found to provide even more severe tests for the BER pattern sensitivity. Most likely, such test words would be derived from the synthesis of a digitized analog signal. For example, a digitized sine wave may prove to be a more poignant test pattern for data derived from certain sources. However, a specific study of test functions was necessarily beyond the scope of this contract.

2.4.2 BER as a Function of Record Level

As stated in Para. 3.2.1, we successively reduced the record current to simulate a degradation of reproduce SNR. Unfortunately, reduction of the record level also affects the amplitude and phase response of the recorder. The relative degradation of BER with phase distortion may be different for different codes, although the extent of this difference is unknown.

Further comments on this effect can be found in Para. 3.2.2, and in Sec. 3.6 of this report.

2.4.3 Pre-Equalization

Time limitations precluded the design of suitable pre-equalizers for each tape speed, to compensate for the effect of speed changes on the amplitude and phase responses of the system. As a consequence, a comparison of results obtained at one tape speed, with those obtained at another, is subject to question. We believe, however, that the major conclusions of our experiments are not materially altered by this omission. Some further comments on pre-equalization are found in Para. 4.1.1.

2.4.4 Bandwidth Limitations

Because of bandwidth limitations, experiments at high bit densities and high tape speeds had to be curtailed, as discussed in Para. 3.2.4 where the detailed test procedure is described.

2.4.5 BER Measurement

In the interest of expeditious experimentation, it was decided to determine the BER under "Read-While-Write" conditions, rather than to record the tape fully, rewind, and then read to determine BER. It was found that our procedure resulted in uniformly lower BER than might have been measured had the tape been first recorded and read later. As this process affected all codes alike, we believe that the procedure used does not invalidate any of the results obtained.

2.5 REFERENCES

- 2.1 A. Miller, U.S. Patent 3,108,261 October 22, 1963.
- 2.2 Wells, Jon B., "High Density PCM Magnetic Tape Recording,"
International Telemetry Conference, 1973, pp. 66-73.

SECTION 3

CODE COMPARISONS

3.1 RECORDING CODES

3.1.1 Need for Code Conversion

The data to be recorded are usually supplied in the NRZ-L code. This code is generally chosen because its low bandwidth requirement in data transmission. Unfortunately, the run-length for ones or zeros is not limited in the NRZ code, with the result that a significant d-c component may be contained in the power spectrum of the data. Indeed, in the case of random data, the spectral density at DC is greater than for any other frequency for all of the NRZ codes (Ref 3), and even though the recording circuit may be DC-coupled, the reproduce process is incapable of reproducing the DC content, as stated earlier.

The bi-phase (or "Manchester") codes have no DC content, since a flux reversal is guaranteed for every bit cell, but they require twice the bandwidth necessary for the NRZ codes. They are therefore not desirable recording codes either. It therefore becomes necessary to convert the data input code into a recording code with little or no DC content, prior to actual recording on tape. After reproduction, the data are then decoded and delivered in the original data input code, to make the recorder/reproducer essentially transparent to the input data. Figure 3 shows the representation of several codes, for an arbitrarily chosen sequence of data bits. The codes tested under this contract are briefly described below. Further information may be found in the quoted references.

3.1.2 Miller Code

One of the most commonly used recording codes, it at once offers the virtue of very little power spectral density at DC, while maintaining the minimum interval between transitions at one bit cell; the maximum run length between

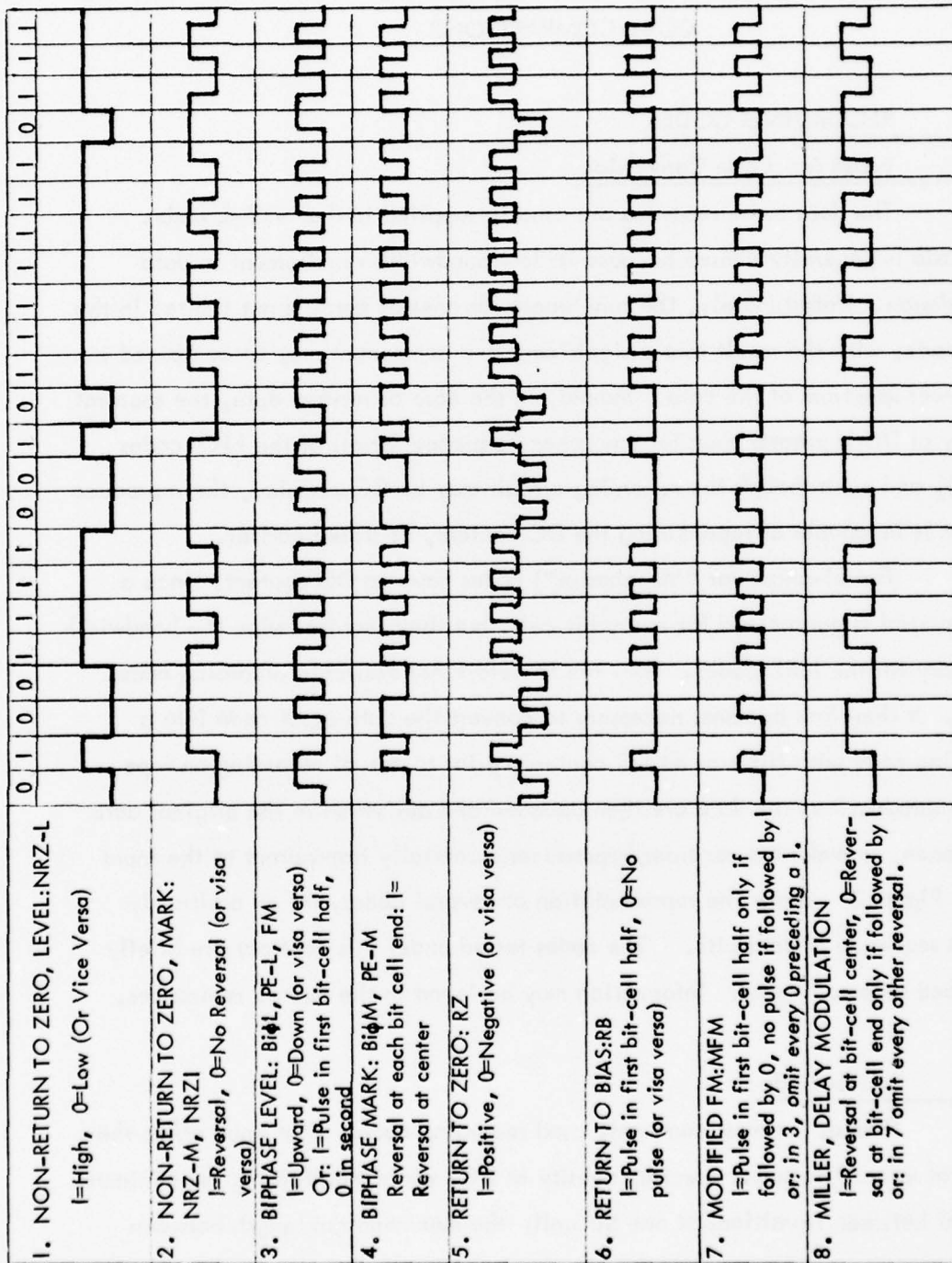

FIGURE 3 DIGITAL RECORDING CODES

transitions cannot be longer than two cells. Thus, the number of transitions per unit time is neither so high as to require wide bandwidth, nor so low as to demand DC-response.

The Miller code is generated by the following rule:

One: Transition in mid-cell.

Zero: Transition at end-of-cell if next bit is a zero.

No transition if next bit is a one.

The code is ambiguous, in that the roles of ones and zeros could be exchanged. Occurrence of a 101 sequence removes this ambiguity, since this is the only pattern than can generate a two-cell run between transitions. Such a 101 sequence will occur sooner or later in the data, but can also be inserted as part of the sync word used for deskewing a multitrack system. (Fig. 1).

The advantage of this code is its relative independence of the low-frequency response of the recorder. Its disadvantage is that transitions can occur at either the center or the end of a bit cell; thus a double-frequency clock is required, and the frequency response of the recorder must be wider than might be suggested by the power spectral density of the Miller code as such. It is therefore somewhat wider than that of any of the NRZ codes.

3.1.3 Modified NRZ (MNRZ)

This code depends upon the insertion of an additional bit after every seven input-data bits. Two versions might be used: The eighth bit could be an odd-parity bit; i.e. the eighth bit can be chosen so as to ensure an odd number of ones in the resulting eight-bit word. This is the version used by Bell & Howell's Datatape Division, and is commonly referred to as the Enhanced NRZ code format. Or, alternatively, the eighth bit can be merely the inversion of the seventh data-bit. In either case, the run length of ones or zeros is limited, and true DC response is not required of the recorder. The choice of the seven-bit input-data word is arbitrary, and a longer or shorter length might have been chosen:

However, a longer run would extend the low-frequency response, whereas a shorter run would increase the "overhead" and thus reduce the coding efficiency. At the 7:1 ratio, the overhead is 12.5 percent (as recorded). The disadvantage of the 7:1 ratio lies in the fact that the bit lengths of commonly used test words, i.e. pseudo-random numbers of 63 and 511 bits respectively, are integral multiples of the data word length, with the result that measured bit-error rate (BER) may be dependent upon the data word itself, i.e. on the instant of connecting the data generator to the recorder (See Para 3.4.1), as seen in Fig. 11.

3.1.3.1 Odd-Parity MNRZ

This method has the significant advantage of offering a measure of the BER of each track as it actually occurs. While it does not provide error correction capability, it does at least allow flagging of insipient system degradation. Its disadvantage lies in the fact that in the worst case the uninterrupted run of ones (or zeros) may extend over 14 bits, which places a significant burden on the low-frequency response of the recorder (Fig. 4a) and increases the probability of bit-errors under conditions of unfavorable data patterns.

3.1.3.2 Inverted-Bit MNRZ

The advantage of this code, over the odd-parity form, lies in the limit of the uninterrupted run length of ones or zeros for the worst-case data patterns: In no case can it extend over more than eight bits (Fig. 4b), and the bit-error probability is therefore lower than for the odd-parity form of MNRZ. For this reason we have chosen the inverted-bit form as the MNRZ representative for the code comparison experiments.

BIT NUMBERS	1	2	3	4	5	6	7	8	9	10	11	12	13	14	15	16
(a) ODD-PARITY MNRZ (ENRZ)	PATTERN 1	0	1	1	1	1	1	1	1	1	1	1	1	1	1	0
	PATTERN 2	1	0	0	0	0	0	0	0	0	0	0	0	0	0	1
(b) INVERTED BIT MNRZ	PATTERN 3						1	0	0	0	0	0	0	0	0	1
	PATTERN 4						0	1	1	1	1	1	1	1	1	0

FIGURE 4 (a) and (b): WORST - CASE PATTERNS FOR MNRZ

3.1.4 M² Code

This code is a modification of the Miller code, but virtually eliminates zero-line drift caused by data patterning. In a recent paper published by Patel (Ref. 3.2) a code's recording efficiency is measured in terms of its density ratio, which is derived from (1) the shortest run length between transitions, (highest transition density), (2) longest run length (lowest density), and (3) the Digital Sum Variation (determined by the accumulated charge at any digit position). The M² code has no d-c content, and should therefore be insensitive to any data patterns. As demonstrated subsequently, this does indeed seem to be the case, and becomes explicitly evident as the linear bit packing density is increased (Section 3.5).

3.1.5 Other Recording Codes

We believe that the codes selected for detailed study represent the most promising codes in current use, and the most economically implemented. There are other possibilities, of course: One might avoid pattern sensitivity by "randomization" of the input-data, according to some rules built into the hardware. This method is employed by one recorder manufacturer. A randomizer of long word length may indeed destroy certain input patterns, but seems to offer little toward improved BER: No provision is made to limit the run lengths of ones or zeros after randomization, and substantial zero-line drift is to be expected. If the randomizer is of comparatively short word length it may even tend to aggravate the pattern sensitivity by creating patterns of its own, and in combination with the input data patterns. Additional encoding is thus required after randomizing.

Another attack on the code conversion problem revolves around replacing groups of bits by longer groups taken from a look-up table, such that there is little or no net DC contribution within these longer groups. This method is similar to Group Code Recording as used in some current computer tape equipment

(Ref. 3.3), and requires an increase in the volume of recorded data, - for example 25 percent increase to change from 4-bit groups to 5-bit groups. For WHIDDA, that large an "overhead" will generally not be acceptable.

For many years, Manchester codes (also known as bi-phase codes) were commonly used on recorders because of the negligible low-frequency energy content of these codes, and because their digital sum variation (See Para 3.1.6) is bounded. However, Manchester codes are double frequency codes which produce significantly broader power spectral densities than NRZ-L, and thus require a substantially wider frequency response of the recorder. They are therefore not useful recording codes for HBR applications.

Suitable modulation methods (AM or FM, for example) can also accommodate DC content of the signal. The frequency spectrum of the recorded modulated signal is substantially wider than that of the input data, however, and once again the bandwidth requirement on the recorder would need to exceed that of the recording codes chosen for comparisons.

3.1.6 Digital-Sum Variation

The presence of DC and of very low frequency components manifests itself as an inability of the recorder to maintain a constant zero level for the reproduced bit sequence. At higher bit packing densities (e.g. at 30 Kb/in and above) this zero-line drift is a major source of bit errors, since bit detection is essentially based on the polarity of the instantaneous signal-value relative to the true zero-line. Severe zero-line drifting will destroy the ability to perform this detection, but even moderate drifts will erode BER performance, since a noise pulse at the moment of detection can easily cause an error. The effect of zero-line drift is usually ameliorated by use of a DC-restorer, which introduces problems of its own (see 3.1.7; also 6.1).

The propensity toward zero-line drift of any given code, is well described by the concept of the Digital-Sum Variation, which is no more than the build-up of charge on a capacitor through which a given bit sequence is passed. Figures 5a, and 5b show the Digital-Sum Variation for the recording codes mentioned thus far. These figures show the zero-line drift derived from some arbitrarily chosen bit-pattern according to Patel (Ref. 3.2), but experimental evidence can be found in Section 3.6 for the codes tested over a range of bit-packing densities, and for test words of pseudo-random numbers (63, 511, and 1023 bits) and of 6-bit samples of ramp functions (repeated 32, 64, and 128 times).

3.1.7 DC Restoration

The recorder/reproducer cannot reproduce the DC content of the input data directly, but it is possible, to some extent, to reestablish the proper DC level prior to bit detection. This is accomplished by determining the amount of low frequency energy lost through the system and then re-inserting a compensating waveform into the signal. Lucky describes a technique used successfully in communication links with NRZ-L data. (Ref. 3.4). His method works well in the types of systems for which it was designed, but it is not satisfactory in the case of a magnetic-tape recorder, since it requires that the input signal to the DC restorer, i.e. the output from the reproduce amplifier, should have essentially constant amplitude. Unfortunately, in high density digital recording there is always a certain amount of amplitude modulation caused by variations in head-to-tape spacing. These are generally of sufficient magnitude to prohibit the use of the type of circuit described by Lucky.

Another method of DC restoration consists of operating directly on observed zero-line shift in the signal. This can be accomplished by mixing the filtered outputs of two half-wave rectifiers, each operating on different halves of the signal. (Fig. 6). If the signal is equally balanced around zero volts, the mixed output will be zero; if it is not, the output of the mixer will have an amplitude proportional to the DC offset of the signal. This

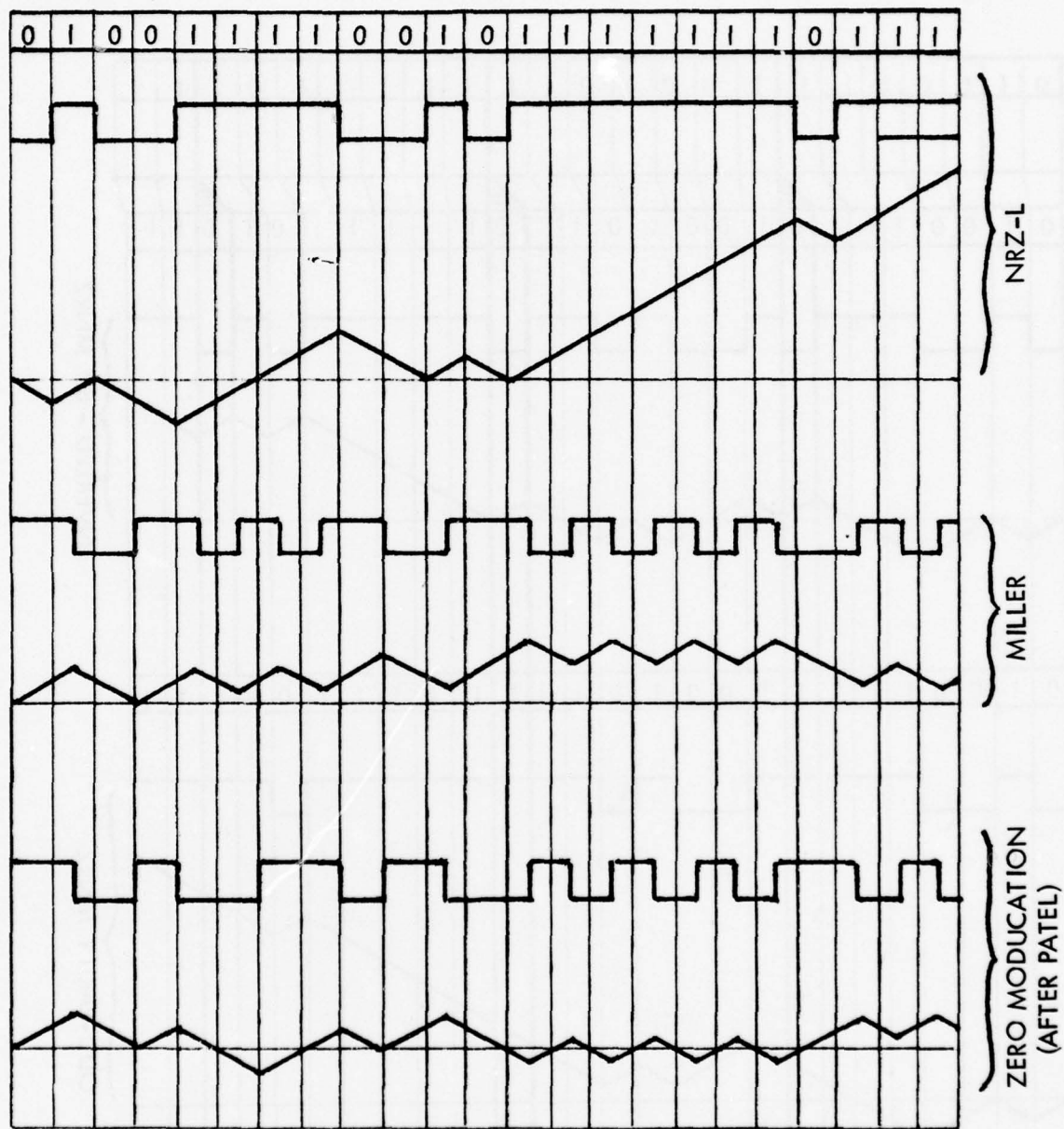

FIGURE 5a BIT PATTERNS AND THEIR DIGITAL-SUM VARIATIONS FOR THE DATA INPUT CODE (NRZ-L) AND TWO RECORDING CODES.

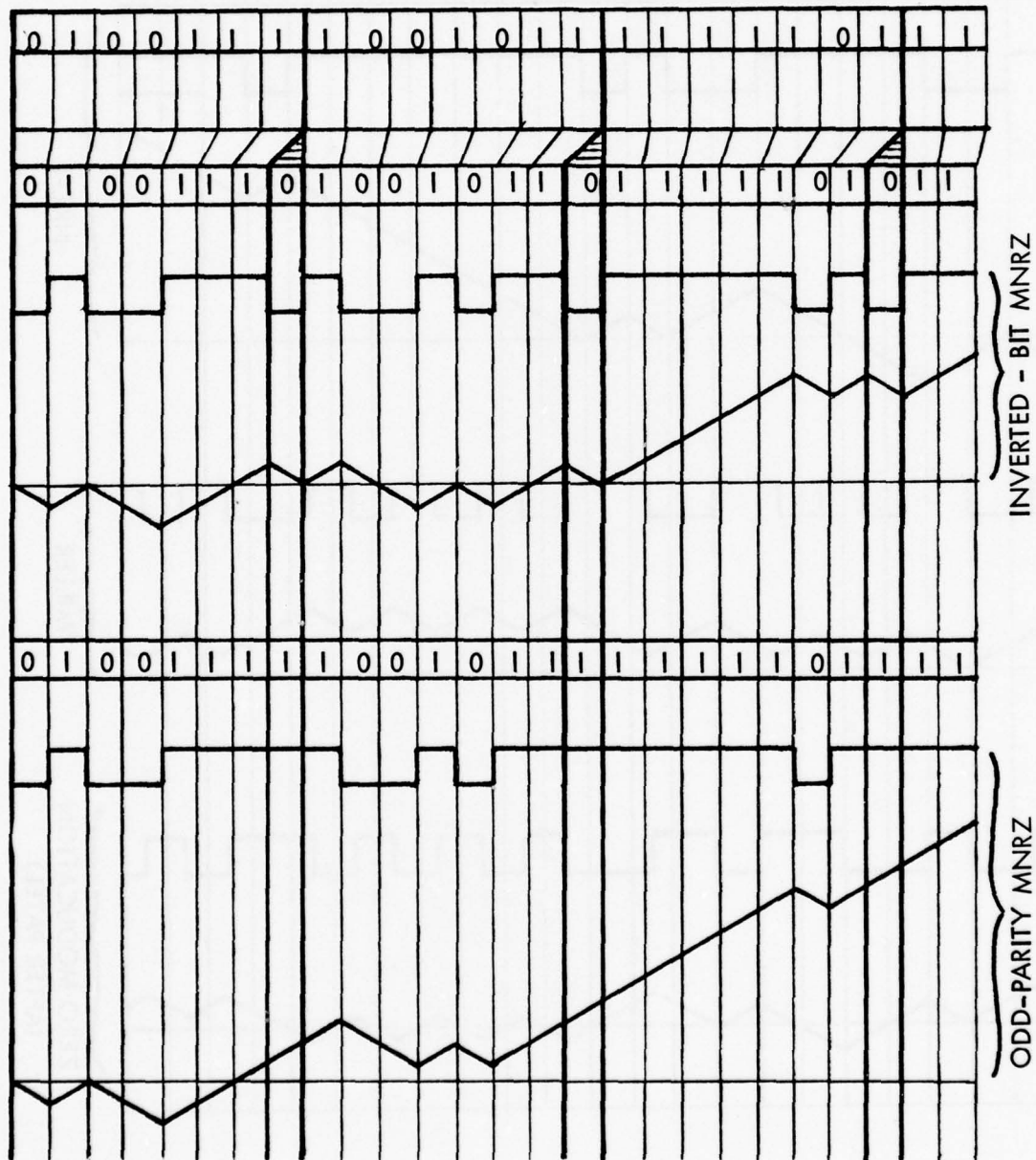

FIGURE 5b BIT PATTERNS AND THEIR DIGITAL SUM VARIATIONS FOR THE TWO MNRZ CODES

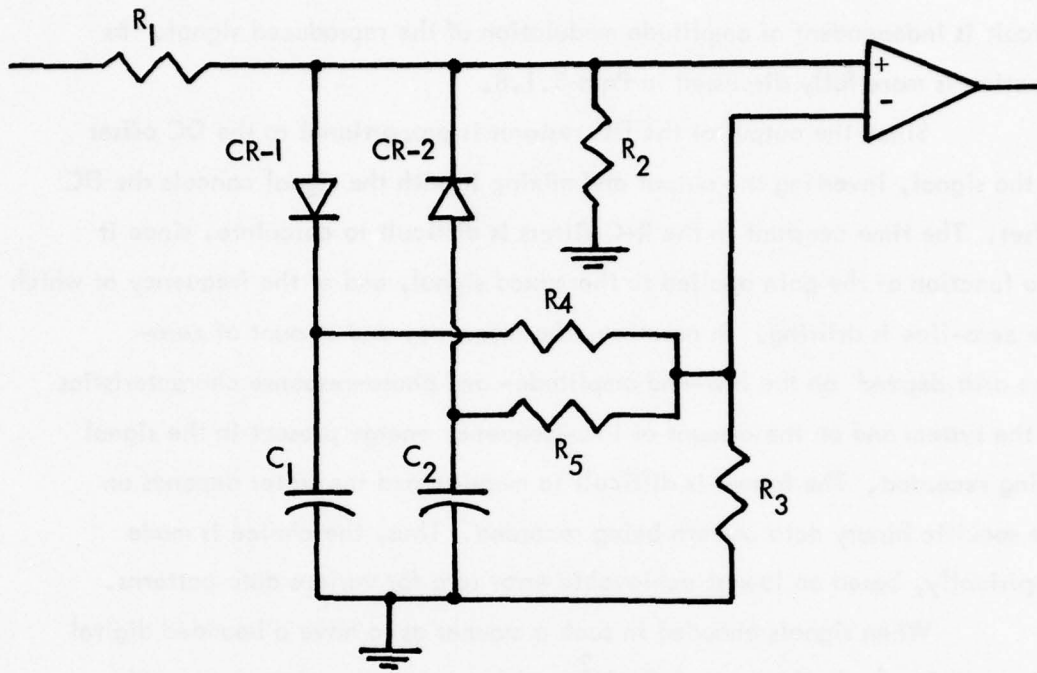

FIGURE 6 DC-RESTORER CIRCUIT

circuit is independent of amplitude modulation of the reproduced signal. Its function is more fully discussed in Para 3.1.8.

Since the output of the DC restorer is proportional to the DC offset of the signal, inverting the output and mixing it with the signal cancels the DC offset. The time constant in the R-C filters is difficult to calculate, since it is a function of the gain applied to the mixed signal, and of the frequency at which the zero-line is drifting. In practice, the frequency and amount of zero-line drift depend on the low-end amplitude- and phase-response characteristics of the system and on the amount of low-frequency energy present in the signal being recorded. The former is difficult to measure and the latter depends on the specific binary data pattern being recorded. Thus, the choice is made empirically, based on lowest achievable error rate for various data patterns.

When signals encoded in such a manner as to have a bounded digital sum variation (as in the case of the M^2 -code) are reproduced on a magnetic-tape recorder, zero-line drift perceived on the signal is difficult to detect, even if the data patterns repeat only six times per second, and the low-end response of the recorder is limited to 400 Hz, for example. Furthermore, there is no measurable improvement in BER when DC restoration is used. Thus, the use of such codes results in a system which is virtually free of pattern sensitivity.

The discussion on DC restoration would not be complete without pointing out that peak detection, as is used in conventional computer-type tape recorders, does not generally require DC restoration. However, as pointed out in Para. 4.1.3, it is basically a noisier method of detection. Since all DC restoration techniques are imperfect in some way, the question remains, whether the use of peak detection without DC restoration would give better results than other modes of detection requiring DC restoration. No work was done within the scope of this contract, to investigate this, or other, DC restorer circuits.

3.1.8 DC-Restorer Circuit

The actual circuit used throughout the code comparison tests is shown in Figure 6; it functions as follows:

When the signal is positive CR-1 conducts. R_1 and C_1 form a low-pass filter whose output is subtracted from the signal. When the signal is negative CR-2 conducts, and R_1 and C_2 form the low-pass filter. If the low-frequency component of the positive portion of the signal has the same amplitude as of the negative portion, (i.e. the case that exists if only amplitude modulation is present), the net voltage at the junction of R4 and R5 is zero, as mentioned in Paragraph 3.1.7; however, if these two components are different (the case when zero-line drift occurs) the signal at the junction of R4 and R5 is proportional to the amount of zero-line drift and the low-frequency content of the signal is restored at the output of the differential amplifier. The circuit is simple, but effective. It will not correct for zero-line drift at all frequencies, but has been found to improve BER significantly.

The values of C_1 and C_2 are chosen empirically, on the basis of lowest BER measurements. If they are too large they will correct for very low-frequency changes of zero-line drift, but will not compensate for changes of zero-line drift at moderate frequencies. If they are too small, they tend to reduce the amplitude of the overall signal. (In the limit, if they were zero, i.e. replaced with an open circuit, the output of the difference amplifier would be zero at all times).

3.2 TEST METHOD AND PROCEDURE

As stated in Section 3.1, we have selected for comparison the following three recording codes, fully with the realization that other meritorious codes might exist, but were regrettably beyond the scope of the program:

- (a) Miller Code
- (b) M^2 - Code
- (c) Inverted Bit-MNRZ

In addition, one might argue the values of various DC-restorers (Para. 3.1.7), and different forms of equalization (Section 4.1). Within the limitations of the program, however, these avenues must remain to be explored.

3.2.1. Record Margin

Additional complications are presented by the inconsistencies between track-to-track of a given recorder, variations with time due to changing head/tape interface conditions, tape nonuniformities, etc. All of these effects tend to cause degradations of BER, compared to optimized conditions.

As an indication of the sensitivity of a given code, to degradation from these and other sources, we have used as a test parameter the "Record Margin" concept introduced by T. A. Jensen:

Through adjustment of record current and equalizer the test track is initially optimized for the recording code under test, for a given tape speed and bit density. The test word for this optimization is a 511-bit pseudo-random number, for each test run. The record current is now progressively reduced, to create decreasing reproduce SNR's. For each step, the corresponding BER is measured. The code allowing the larger record margin for a given BER, will yield superior system performance.

3.2.2 Validity of the Record Margin Test

The record margin test offers a convenient method of making relative comparisons between various codes. It is not without faults however: When the record-head current is varied, the signal-to-noise ratio at the output of the reproduce amplifier is not the only parameter that varies: frequency response and phase response are also affected, particularly in the case of non-bias recording.

Thus it might be correctly argued that the record margin is not a true "margin", and that the observed increase in BER is not entirely due to the SNR degradation, but is partially due to changes in intersymbol interference

caused by the changes in frequency and phase response with record level.

Bit errors are caused by noise, intersymbol interference due to variations in frequency and phase response (normally interpreted to mean lack of sufficient high frequency response) and zero-line drift due to lack of DC response. Unfortunately, it is not possible to identify a particular bit error as having been caused by noise, another bit error as having been caused by intersymbol interference, etc, since the effects are cumulative. Thus, what has been termed record margin in this report is a more complex parameter than it may at first appear to be.

3.2.3 Interpretation of Record Margin Tests

These limitations should not negate the validity of the tests, providing the data are interpreted properly. The purpose of the test is to determine the relative merits of various codes as regards their ability to achieve high packing density under true operating conditions. The real question to be answered is then: "Is code A better or worse than Code B at high bit-packing densities?" Whether code A is better than code B because it is less susceptible to degradation of SNR or because it is less susceptible to changes in frequency or phase response distortions is unimportant providing we are reasonably careful to assure that the same procedure is used in testing each code, and we recognize the limitations inherent in any procedure used.

Thus, it is felt that on the basis of properly interpreted test results we can state that code A is superior to code B at high packing density if the test results on code A are grouped such as to produce a better record margin than the test results on code B. On the other hand, to imply that the quantitative measure of how much better it is, is equal to "X" db, may be misleading since the tolerance on X is difficult to establish.

3.2.4 Detailed Test Procedure

For each of the three codes we measured BER as a function of record margin, for tape speeds of 30, 60, and 120 inches/second and bit-packing densities of 10, 20, 30, 40 and 50 Kb/in as far as allowed by the frequency limit of the test track (See Sec. 2.4). The range of these frequencies is indicated in the table below:

Kb/in in/sec	10	20	30	40	50
30	0.3	0.6	0.9	1.2	1.5
60	0.6	1.2	1.8	2.4	3.0

Table 3.1 Test Track Bit Rates in Mb/s

We measured the BER for the selected codes, each with three pseudo-random words (63, 511, and 1023 bits) and with the 6-bit words of a sampled ramp function (each word repeated 32, 64, and 128 times).

In addition to measuring BER, we obtained photographs of the oscilloscope presentations of eye patterns, bit wave shapes and zero-line drift after equalization), of the spectrograms (before the encoder), for most of these test conditions.

3.2.5 Step-by-Step Optimization Procedure

In order to achieve a low BER at zero dB record margin, for the 511-bit pseudo-random number used as the initial test word for system optimization, the following step-by-step procedure was used in all cases.

- (a) A capacitance value was selected for the DC-restorer (C_1 and C_2 in Figure 6).
- (b) Equalizer components were selected.
- (c) The record current was adjusted for maximum signal at the upper edge of the signal spectrum.
- (d) For all BER tests on Miller and MNRZ codes, the record current was then reduced by two dB, since this was found to reduce BER. This reduction, however, was found to be deleterious to the M^2 code.
- (e) The equalizer was now adjusted for optimum eye pattern (See Section 3.5) and minimum error signal in the VCO of the bit synchronizer.
- (f) Steps (a), (c) and (e) were iterated as often as necessary, until no further improvement resulted, in the appearance of the eye pattern, the VCO error current, and the measured BER.

3.2.6 Limitations and Inconsistencies

The detailed experimental results are subject to some questioning for reasons mentioned below. However, we believe that the major overall conclusions are in no way affected by such minor variations from our results, had a different procedure been used:

- (a) As stated earlier, a more demanding test word might have been selected, to establish the zero-db record margin condition. Of course, some of the codes would then have been quite intolerant of a significant decrease in SNR, i.e. would have allowed for little or no record margin.

- (b) We chose to ignore error bursts, in plotting the BER curves. This is justifiable to some extent, since tape dropouts, or head-to-tape interface problems, are variables not attributable to the code under test.
- (c) The DC-restorer circuit was varied as stated in Para. 3.2.5; in some instances, no DC-restorer was used. Most probably, the DC-restorer should be varied to fit the test word used, and not necessarily be chosen for the 511-bit pseudo-random number.
- (d) The data receiver/comparator can be used in two modes, as explained in 3.3.3.1: In one mode, each bit error creates one error count, but if a bit-slip occurs the system drops out of synchronism altogether and the error count virtually "explodes". In the other mode, the system will automatically re-synchronize if a bit-slip occurs, but then the error count will be high, sometimes by a factor of three. We have plotted the BER curves without regard to the operating mode of the comparator, in the belief that a factor of two or three was insignificant, where the curves may range over seven orders of magnitude.
- (e) Different bit-detectors might be more useful for some, or all of the codes tested, than the type used throughout our experiment.

3.3 EXPERIMENTAL SET-UP

3.3.1 Tape Transport and Electronics

A 14-track FR-2000 transport was used as the test vehicle. One track was selected and adjusted for optimum operation at all times. Use of the Acculoop tape path has assured negligible head wear over the duration of the tests. The characteristics of the head assembly can therefore be considered fixed. Proper

attention was given to proper maintenance, such as cleaning of heads and guides, etc.

3.3.2 Test Tape

To assure essential independence of the code comparisons from the quality of the recording tape, the best tape known today was used: Ampex 799 tape is not only especially designed for PCM recording, but has been pretested on 14 tracks of a 28-track format; as a result, it is guaranteed to have no more than one dropout per 100-foot tape length, and all dropouts are required to be statistically independent so as to preclude simultaneous dropouts on several tracks. A dropout is defined as a signal loss of 12 dB, and lasting 1.0 microsecond, for a 1.0 megahertz sine wave reproduced at a tape speed of 120 in/s, on 25-mil wide tracks. (See Appendix 6.2)

Use of this tape, together with the 14-track format, assures that each of the 14 tracks has been tested, albeit to only half-width. The BER is thus only minimally affected by the recording tape.

3.3.3 Test Circuit

Figure 7 illustrates the experimental set-up in block diagram form. Two types of data generators were used, together with their companion data-receivers (comparators). One Datapulse 213A was used as the generator, and another as the comparator. The generation and bit-by-bit comparison of the ramp functions was accomplished through the use of a device specially designed and constructed by Ampex for this purpose.

3.3.3.1 Datapulse 213 A Pseudo-random Word Generator and Comparator

The 213A can be used as either a data generator or a data receiver/comparator. As a generator it consists of a shift register with various feed-back taps, for selection of the desired word length. To generate a 63-bit pseudo-random

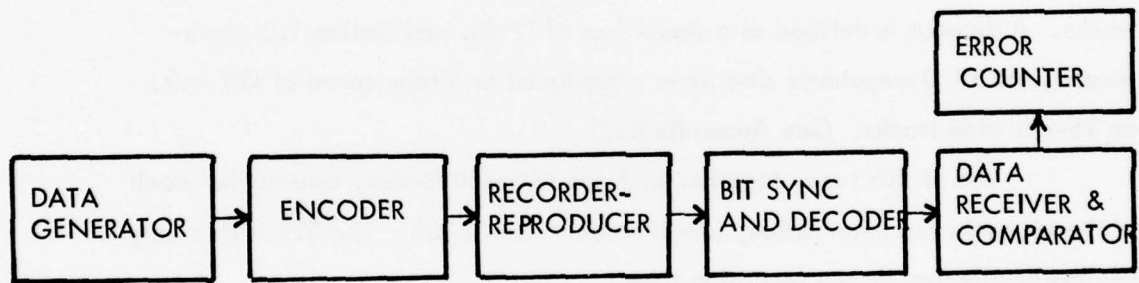

FIGURE 7 BLOCK DIAGRAM OF TEST CIRCUIT

word, a 6-bit shift register is used in the manner shown in Fig 8. To test for bit errors, the 213A is configured as in Fig 9.

When used as a data receiver, it is necessary to synchronize the output of the register with the incoming 63-bit word. This is accomplished by closing the sync switch shown in Fig 9. This switch need only be closed long enough to allow 6 bits of data to enter the register. Once this is done the word generated by the register will be identical to the word being received and a bit by bit comparison will be made at XOR#2.

The 213A offers 2 modes of operation. In one mode the sync switch is a push button with momentary closure, in the other it can be permanently closed. In the momentary mode, each bit error creates one error pulse at the output. If a bit-slip occurs the system drops out of synchronism and counts innumerable errors, until the sync switch is once again momentarily closed.

In the mode where the sync switch is left permanently closed, the system is self-synchronizing and bit slips will not be detected; nor will they cause the system to drop out of synchronism. However, if a singular bit error occurs in this mode, it is not only detected, but it also enters the shift register. When this erroneous bit reaches FF₅ it will generate the wrong output from XOR#1 and an error will be indicated. When the erroneous bit reaches FF₆ another error is indicated. Thus, in this mode each singular bit error results in an indication of three errors. One cannot arbitrarily divide the error count by three, however; if two errors occur at the input, one initially and one just as the initial error has traversed the shift register to FF₅, the second error will not be detected.

The choice of operating mode depends on the probability of bit slip. In general, the comparator is used with the sync switch permanently closed when the machine is initially adjusted, e.g. during amplitude and phase equalization; the momentary mode is used to make final BER measurements.

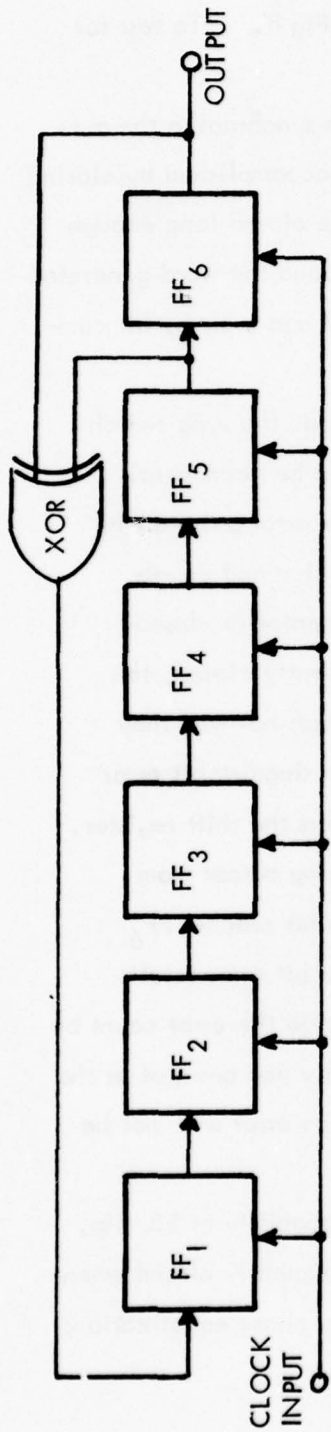

Figure 8. Data Pulse 213A Pseudo-Random Number Generator

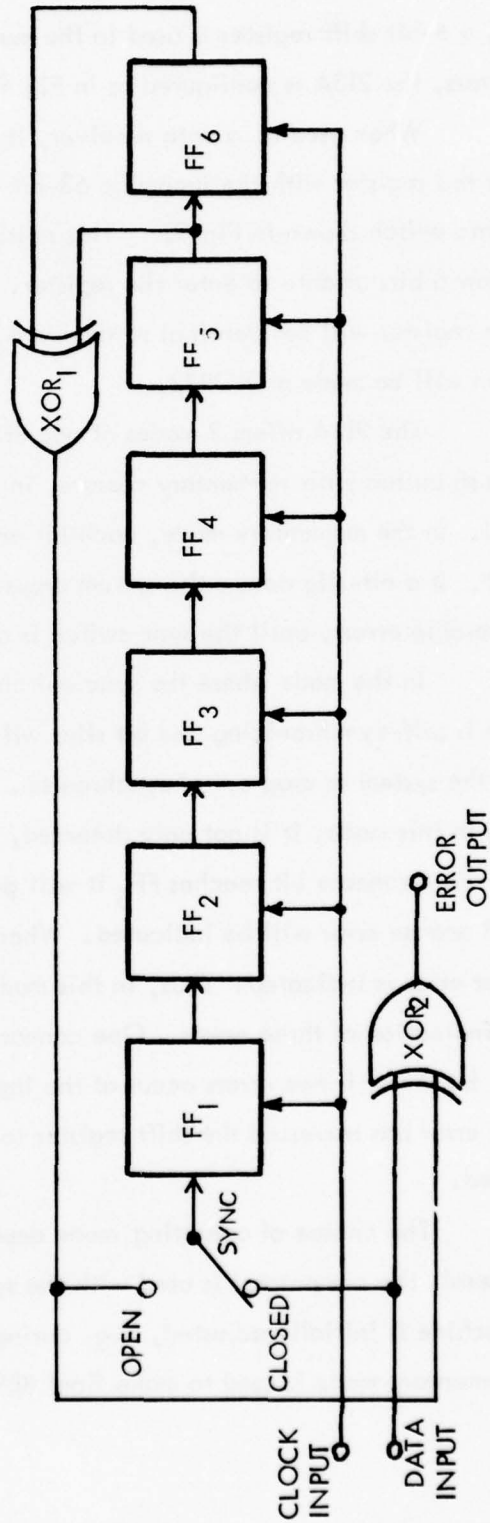

Figure 9. Data Pulse 213A Pseudo-Random Number Comparator

3.3.3.2 Ramp Generator

The use of a pseudo-random test pattern does not take into account problems arising from the inability of the recorder to reproduce low frequencies (e.g. below 400 Hz). For example, at a packing density of 30 Kb/in at 30 in/s the bit rate will be 900 Kb/s. When a 63-bit word is used at 900 Kb/s, the wave form is repetitive every 63 bits, which results in a line spectrum whose lowest frequency is $900,000/63 = 14.3$ KHz. Of course, longer pseudo-random words would result in portions of the spectrum falling below 400 Hz, but in the case of Miller code the amount of energy would be minimal. To generate patterns having enough low-frequency content to cause a degradation in BER as a result of the inability of the recorder to pass frequencies below 400 Hz, requires a special data generator/comparator.

The special unit used in our tests is called a ramp generator and is shown in simplified form in Fig. 10. The six-bit binary counter parallel-loads a 6-bit shift register which is clocked out serially. The divider in the clock is such that the 6-bit serial word can be repeatedly generated from 2 to 128 times, before the next 6-bit word is generated. The name "ramp generator" comes from the fact that if the output of the counter is fed to a Digital-to-Analog converter, its output will be an analog ramp signal. Compared with the 63-bit pseudo-random word, for which the lowest frequency at 600 Kb/s was seen to be 14.3 KHz, the lowest frequency of the line spectrum is now 18.3 Hz, for the case of 128 successive repetitions.

Detection of bit errors is achieved by using an identical ramp generator as a data comparator. Synchronization is accomplished by presetting the counter to zero whenever 12 zeros in a row are seen in the incoming data.

We have found the ramp generator particularly useful in studying the pattern sensitivity of any given recording code.

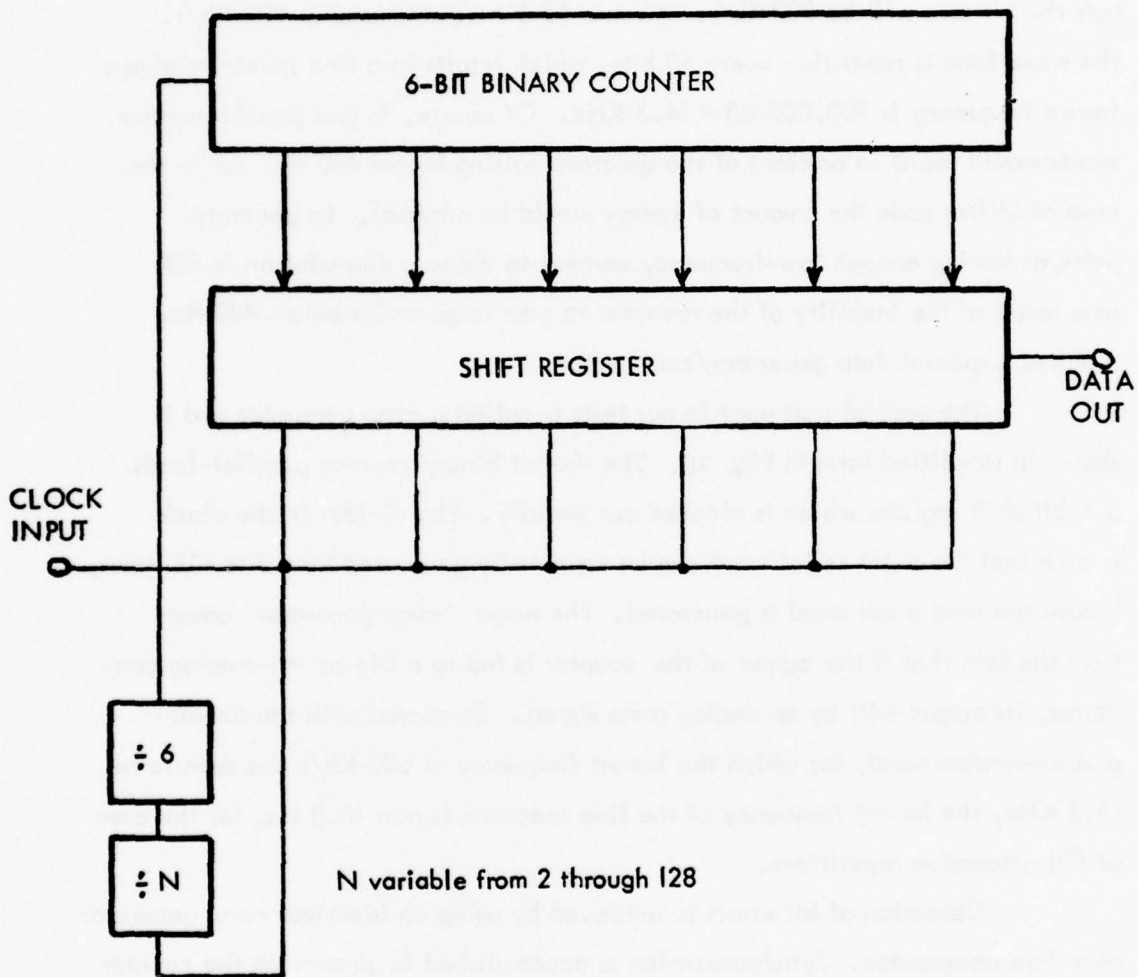

Figure 10. Ramp Generator

3.4 BIT ERROR MEASUREMENTS

The results of the bit-error tests are plotted in Figs. 12 and 13; it was mentioned earlier that these results of the code comparison should be taken as highly indicative, but not necessarily as conclusive in the detail. There remain minor questions regarding the validity of the Record Margin concepts (Para 2.4.2 and 3.2.2); also, the course of the test itself, and the nature of the available test equipment generate additional areas of potential diffidence (Para 3.2.6 and 3.3.3). In the following paragraphs we once more review some of these aspects, and offer additional comments necessary for the objective analysis of the test results.

3.4.1 Pattern Sensitivity

In Para 3.1.3 we mentioned the reasons for the pattern sensitivity of the MNRZ code. We also noted that the divisibility by seven, of the length of two commonly used pseudo-random words (63 and 511 bits) will cause pattern sensitivity if the code is based on a 7:1 ratio (i.e. insertion of the inverted seventh bit, as the eighth bit; presumably the same effect results in the case of inserting an eighth parity bit after seven data bits). One may, therefore, conclude that this form of pattern sensitivity is uniquely related to the choice of the test word, and does not necessarily describe a typical practical application.

Figure 11 shows the result of random application of a 511-bit pseudo-random number in inverted-bit MNRZ, otherwise identical circuit and operating conditions. Depending upon switch closure, the measured BER ranges over five orders of magnitude. We observed that the zero-line drift, and the measured BER, depend upon the actual location of the inserted eighth bit, relative to the bit-sequence composing the pseudo-random test word of 63 or 511 bits. For example, at 40 Kb/in and 60 in/s, with a record margin of 2.5 dB, the BER for the 511-bit test word was measured as 2.4×10^{-4} ; when a new recording was

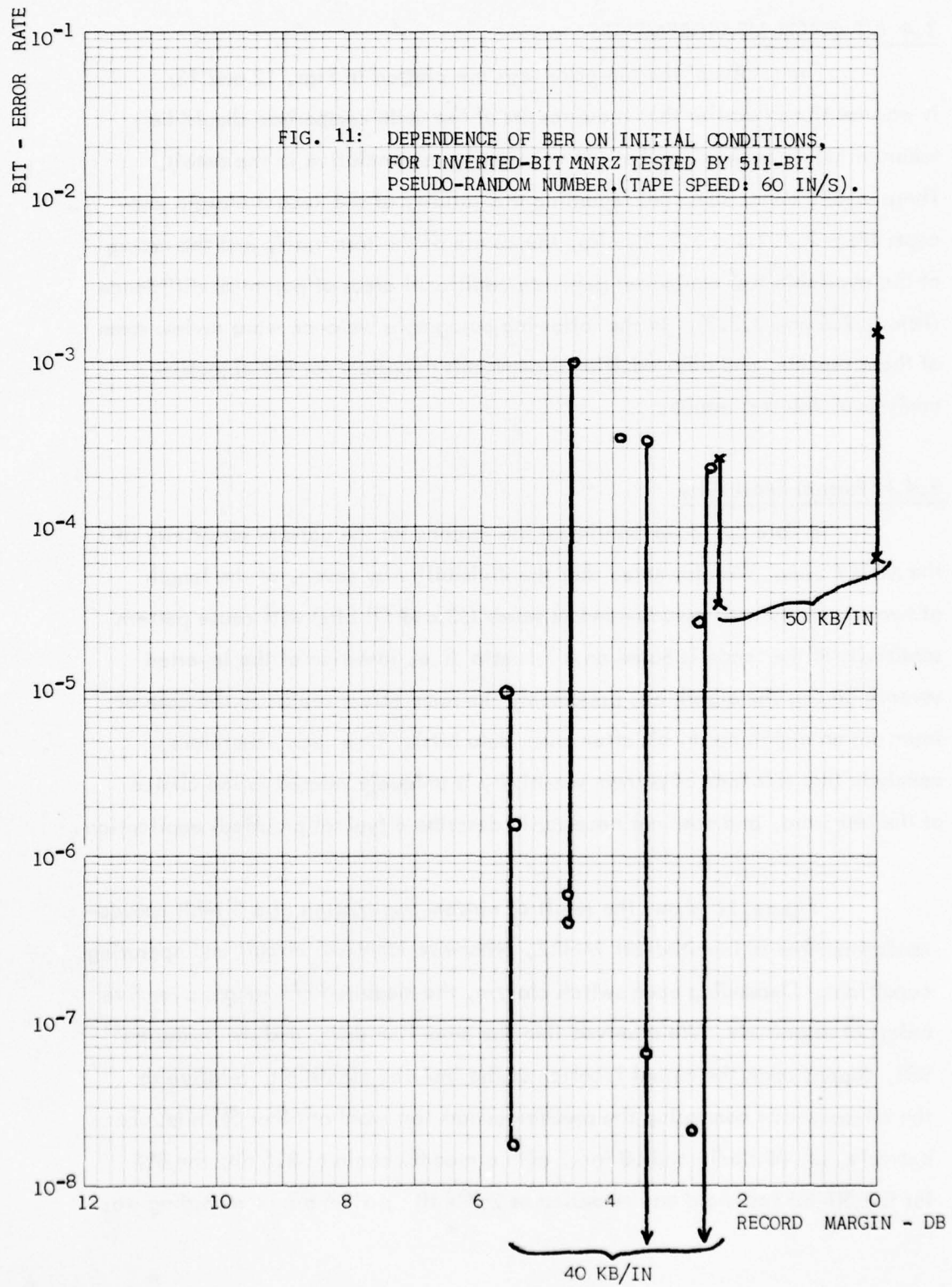

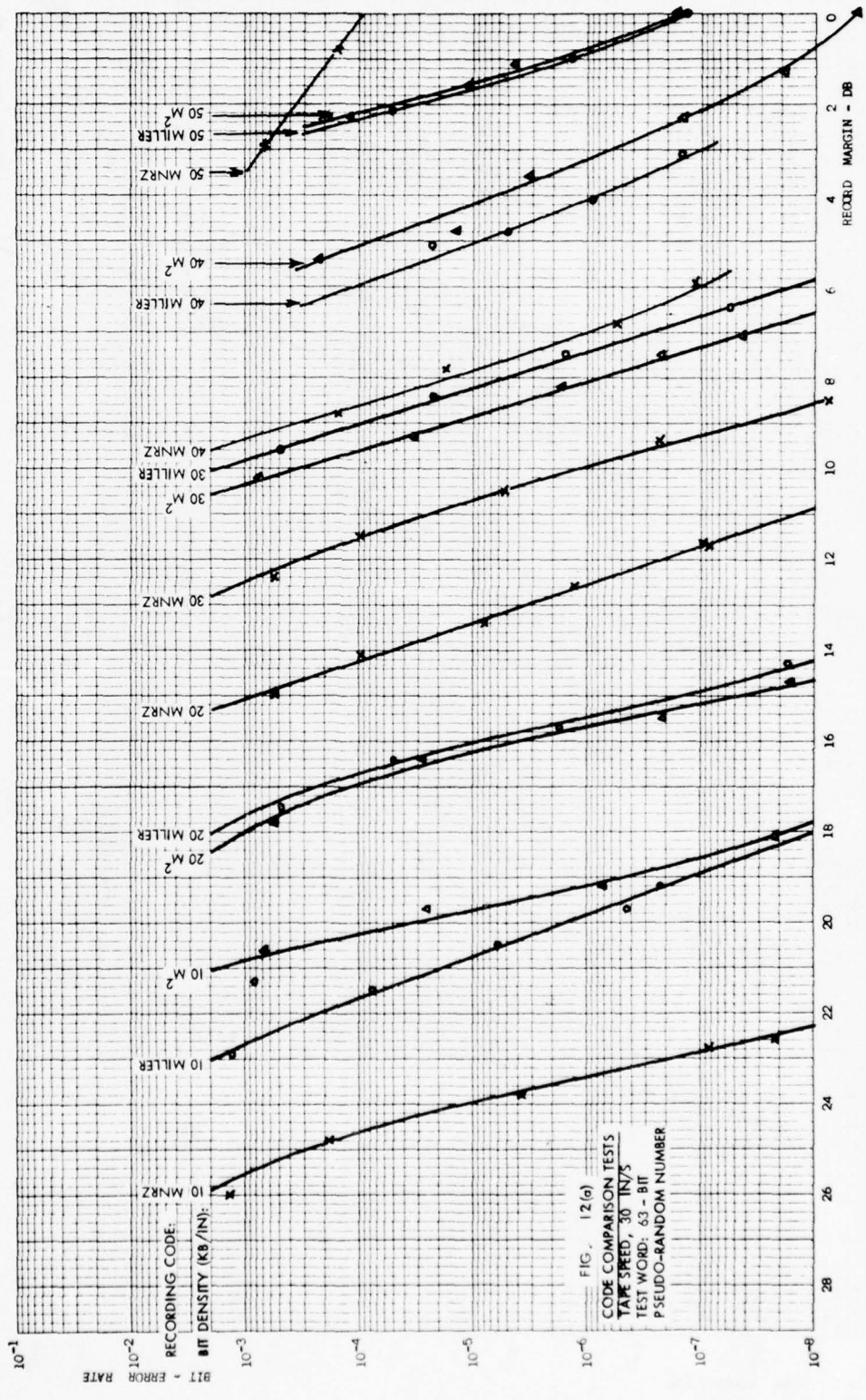

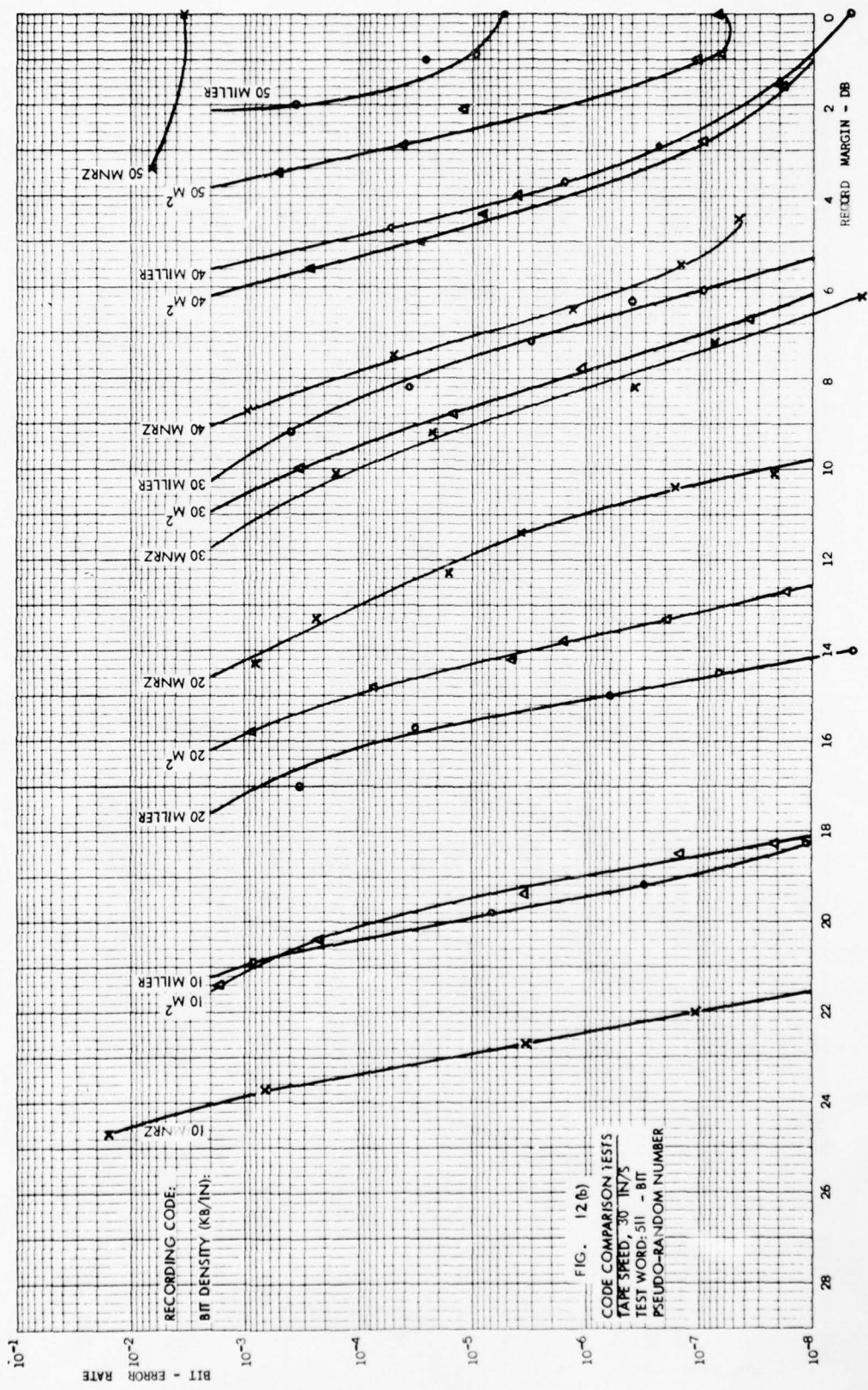

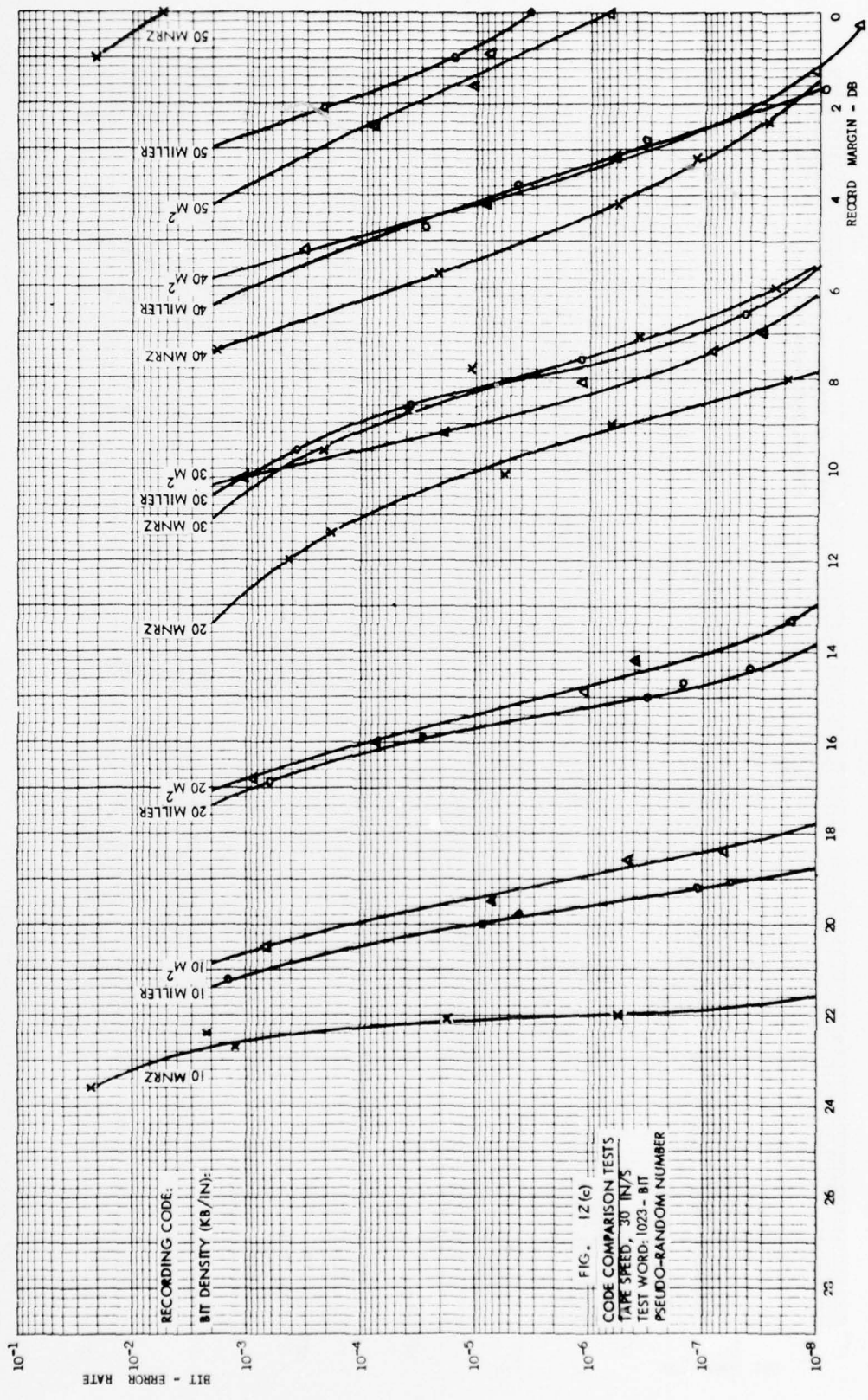

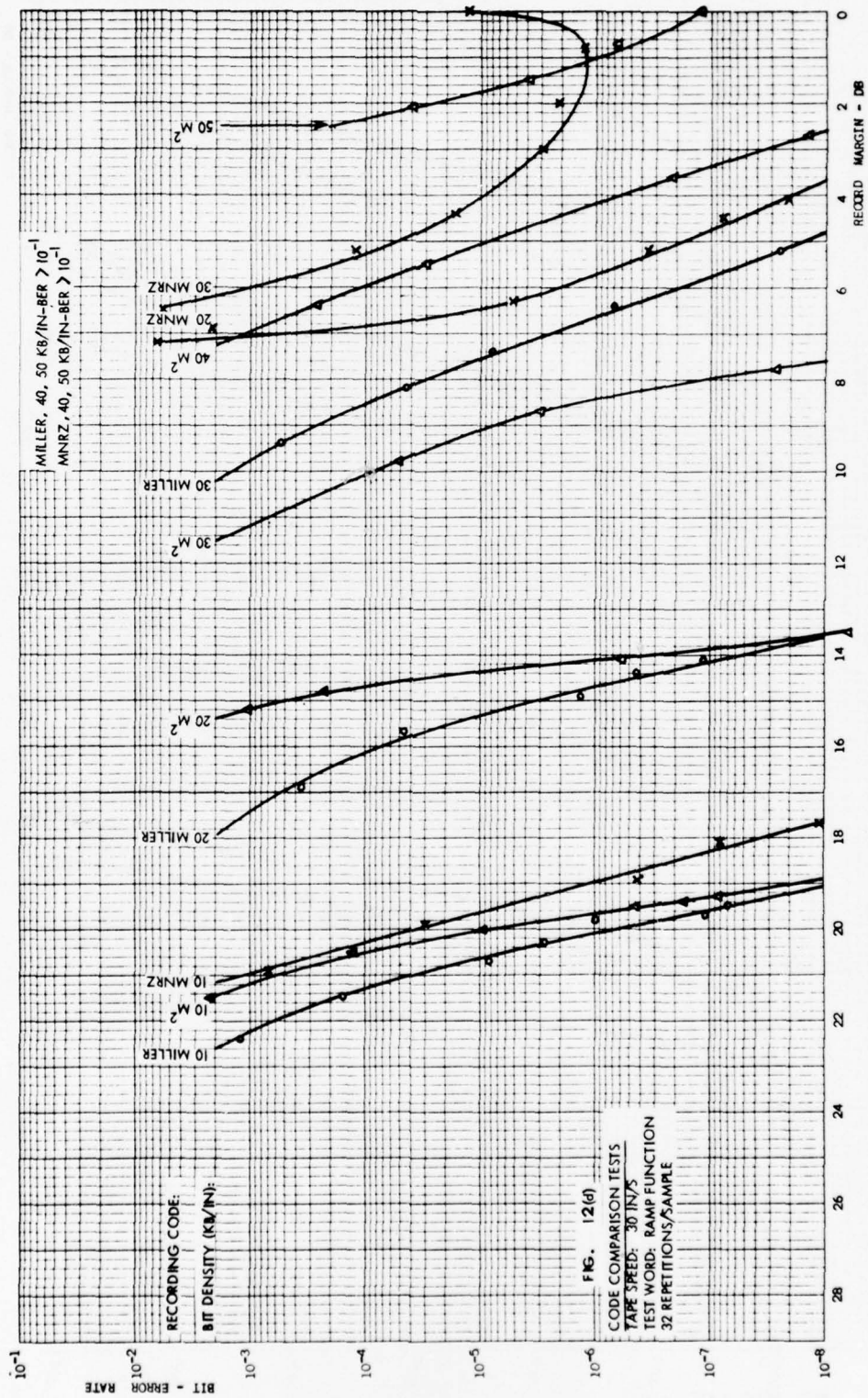

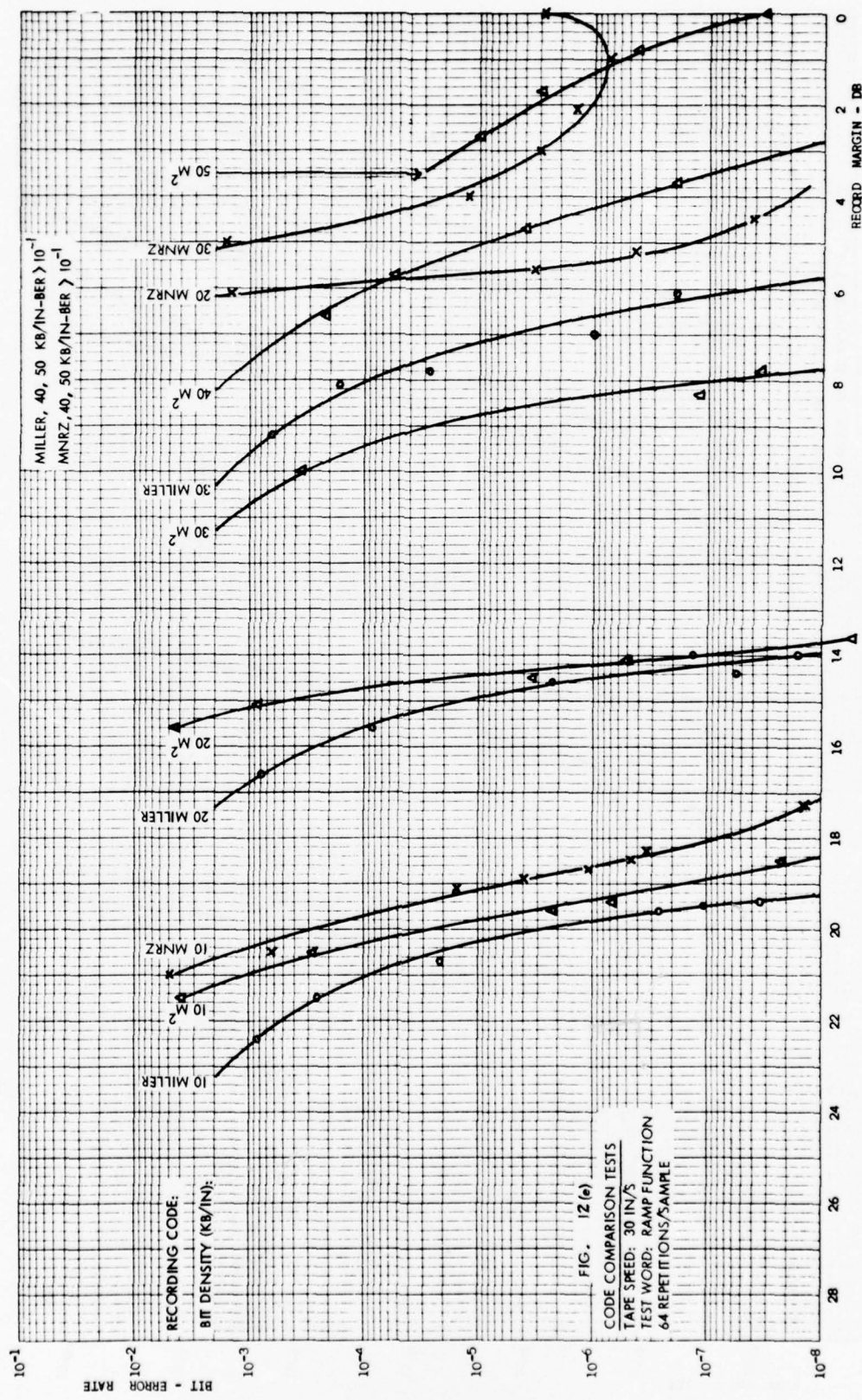
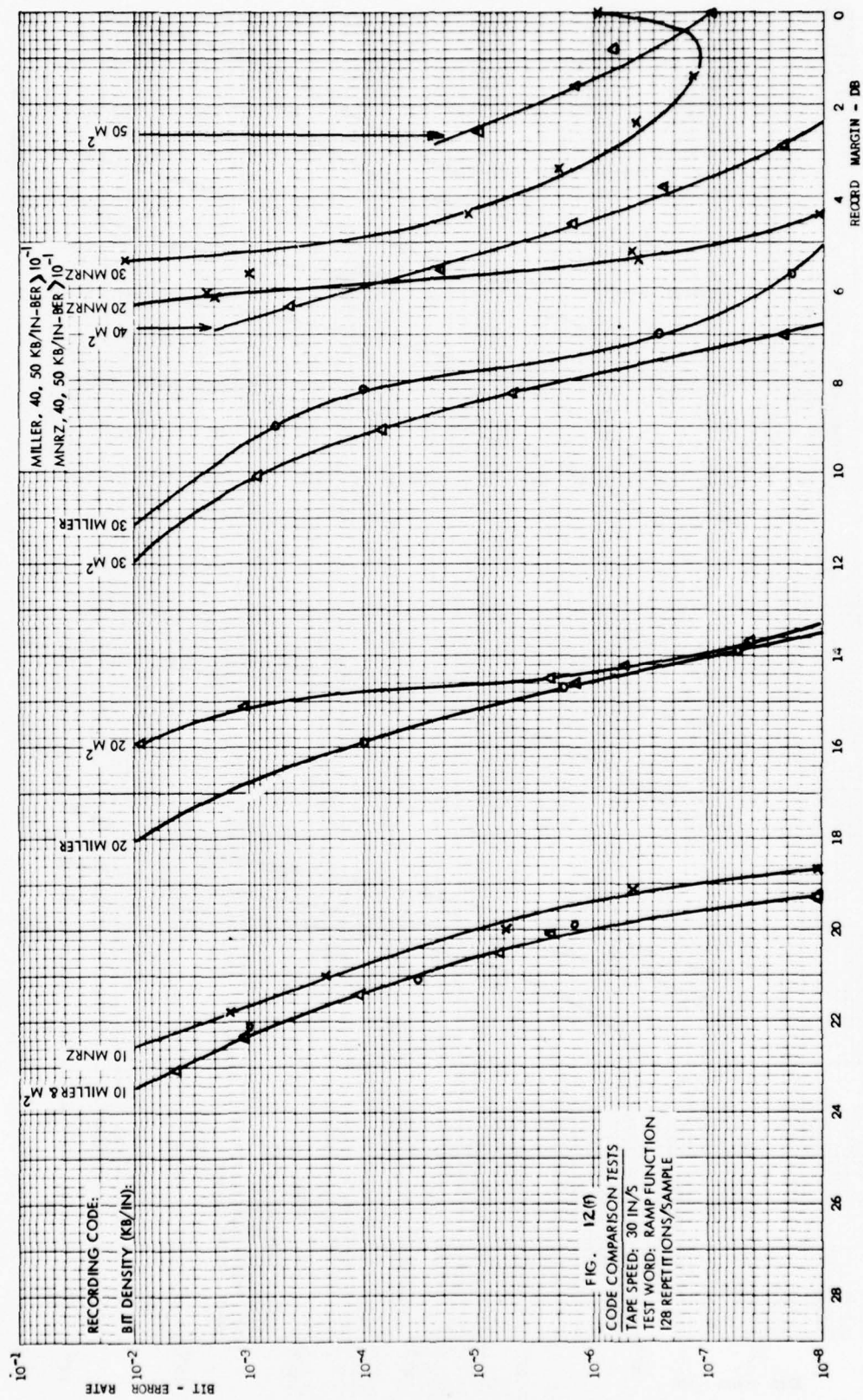
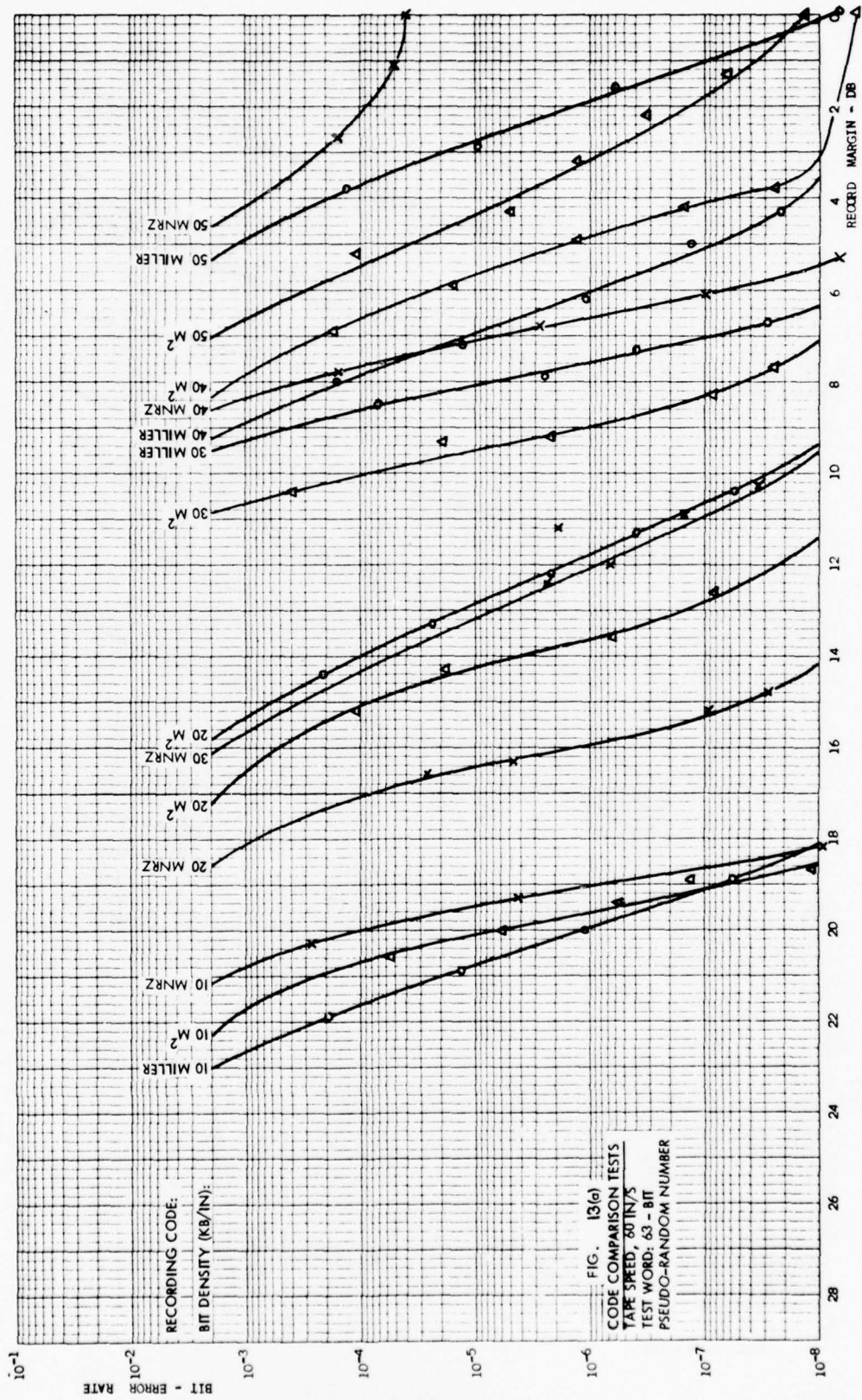
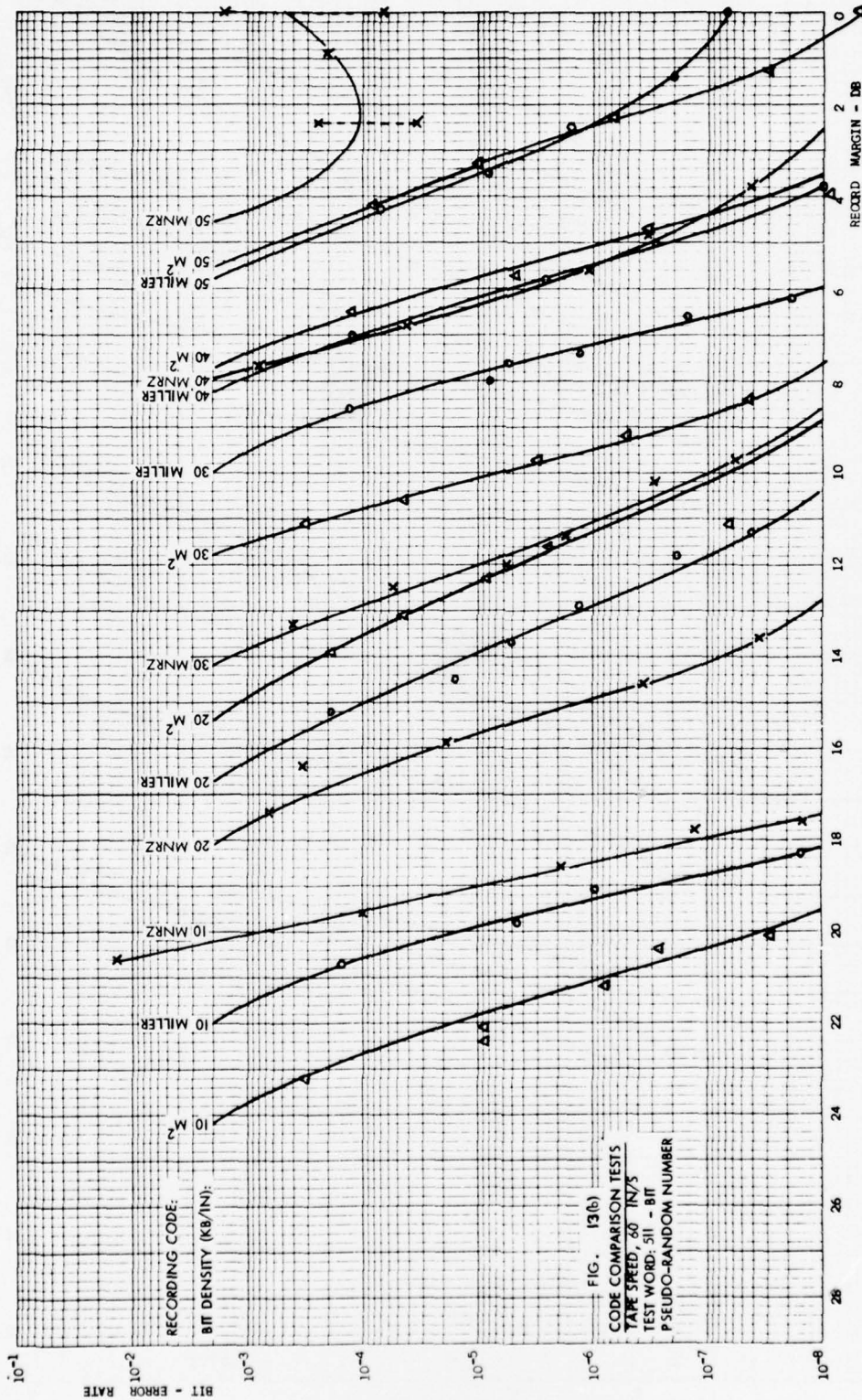
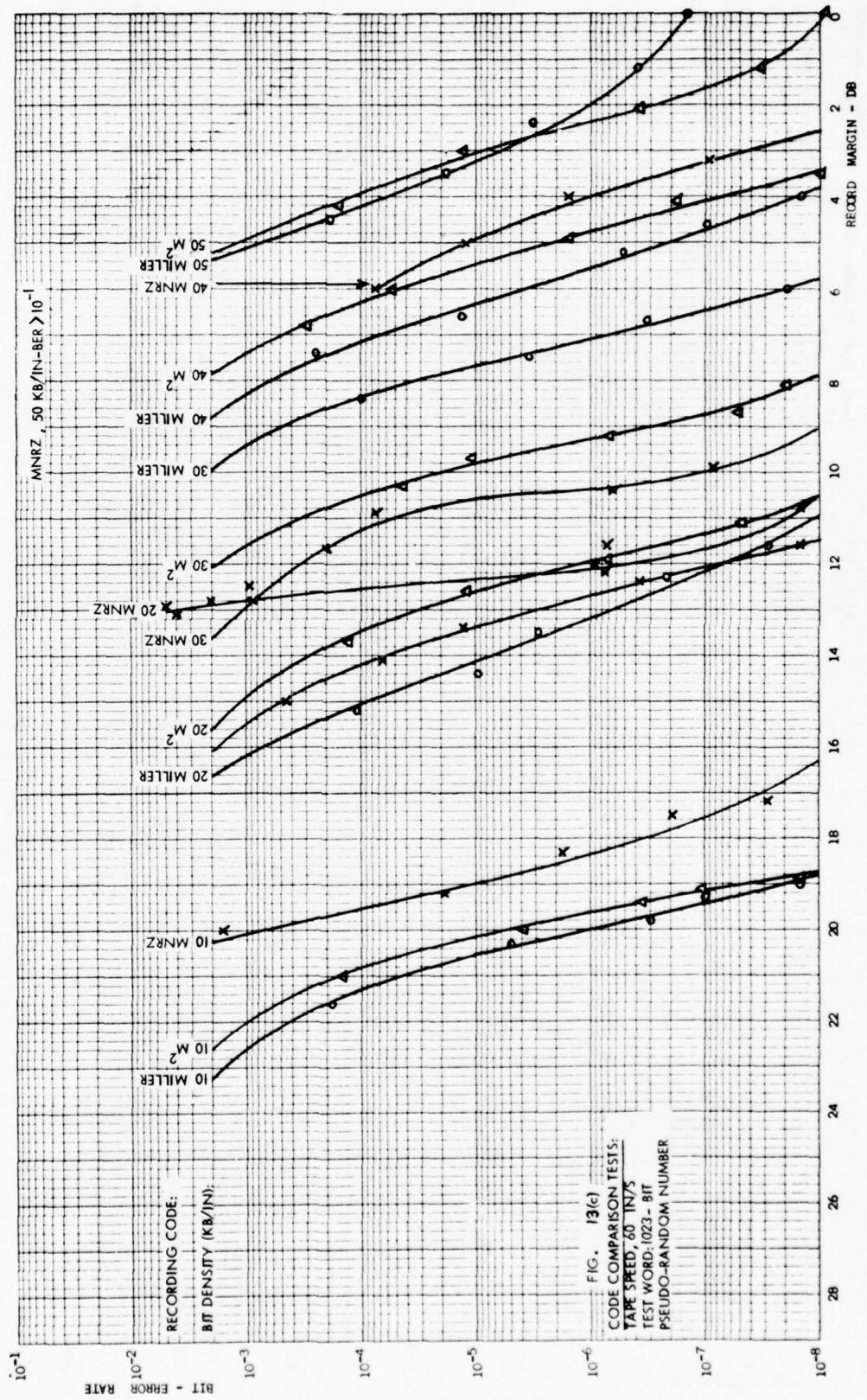

FIG. 12 (e)









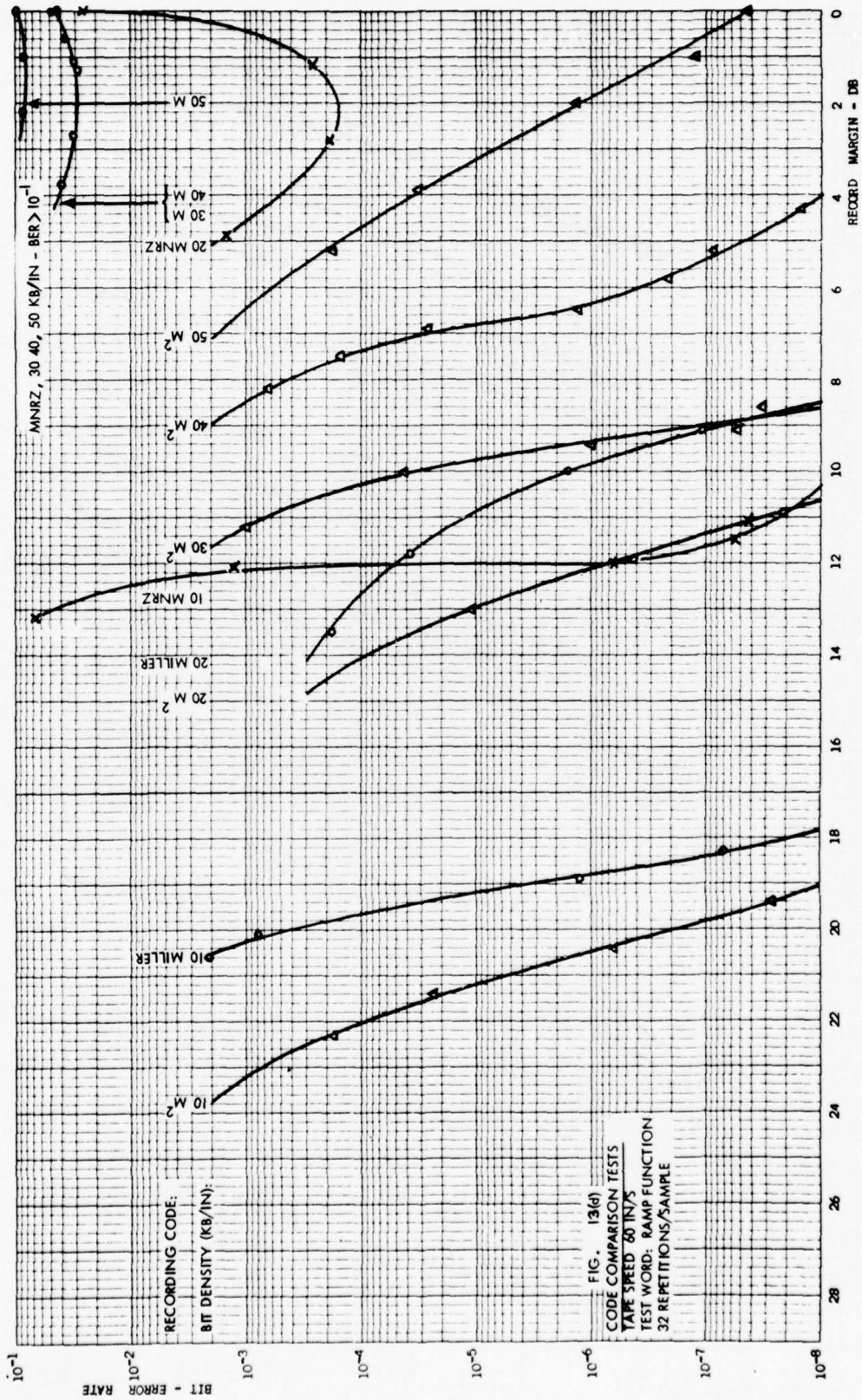

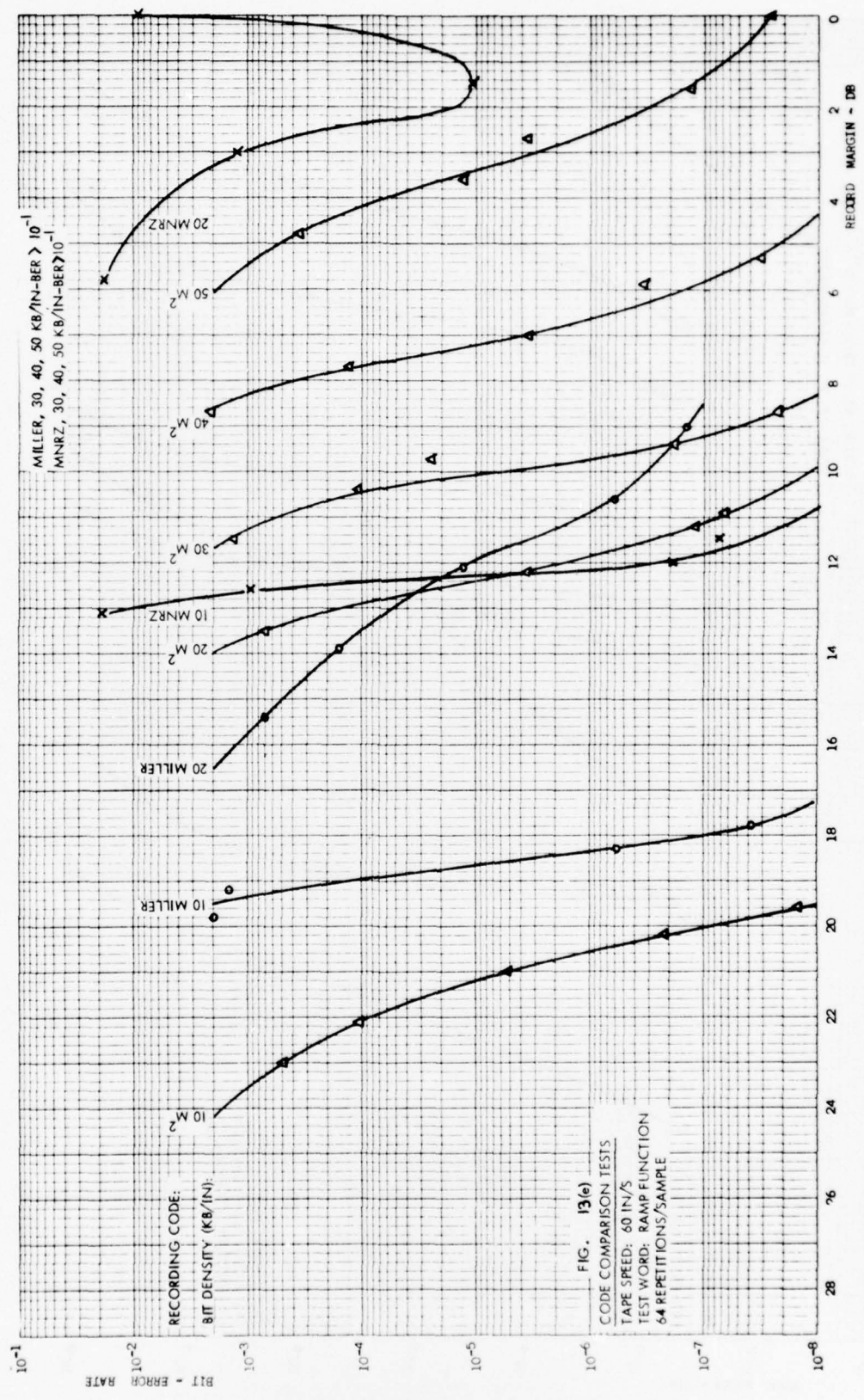
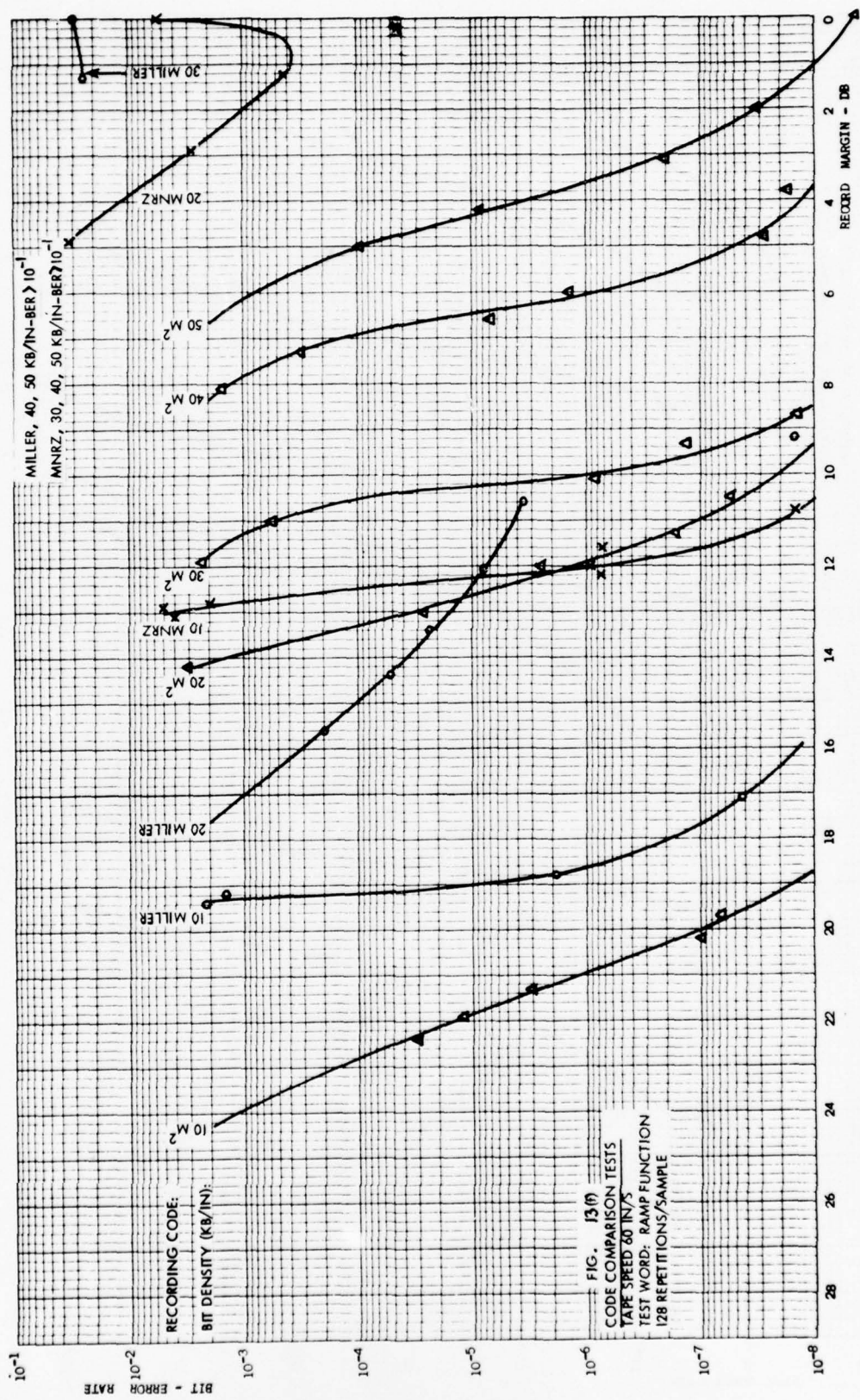

FIG. 13(e)
 CODE COMPARISON TESTS
 TAPE SPEED: 60 IN/S
 TEST WORD: RAMP FUNCTION
 64 REPETITIONS/SAMPLE



made after changing the location of the eighth bit, the BER improved to 1.9×10^{-8} . This difficulty was not observed for the 1023-bit test word since its length is not integrally divisible by seven.

In addition to the problem of zero-line drift, and consequent BER degradation, depending upon signal application during the record process, a seemingly similar problem was observed during reproduction: For the 63-bit pseudo-random number as the test word, excessive BER was indicated, even though the bit-synchronizer was locked up. As many as six re-runs were frequently needed, without any changes or adjustments having been made, before a suitably low BER performance could be measured. In the case of the 511-bit test word this phenomenon occurred far less often, although for as long as perhaps five seconds (at 1.0 Mb/S) the BER would remain high, before settling to a lower value. This problem was not observed for the 1023-bit word, nor for the Miller and M^2 codes.

3.4.2 Optimization for Zero DB Record Margin

In Para 3.1.7 we discussed the general problem of DC-restoration, and the specific circuit employed in our test set-up. We also discussed in Para 3.2.1 the concept of the Jensen Record Margin test, in preparation of which the test circuit is initially optimized on the basis of a 511-bit pseudo-random word, for the recording code under test.

We now note that the curves of BER versus Record Margin for the Miller code and MNRZ might well have been grouped more closely together, had the most demanding test pattern, namely the six-bit ramp function samples, each repeated 128 times, been used for initial optimization. This is explained by the fact that this test pattern tends to create the most severe zero-line drift, and equalizer and DC restorer must perform at their best: The equalizer is adjusted for maximum high-frequency boost without causing excessive phase shift and high-frequency noise, and the capacitance of the DC-restorer is made as small as possible to preclude excessive high-frequency roll-off simultaneous with DC-restoration.

Different results are obtained, depending upon whether initial optimization is achieved on the basis of a 511-bit pseudo-random number (as was the standard for all tests), or of a ramp function whose six bit samples are repeated 128 times (i.e. 49, 152 bits/word) for example. This is shown in Table 3.2 below (all data were taken at 20 Kb/in):

Initial Set-up	Subsequent Test	Tape Speed in/s	Bit Rate Mb/s	DC-Restorer Capacitor μF	BER @ 0 dB Margin	Record Margin for BER = 10^{-6}
49,152-bit Ramp	511-bit pseudo-random no.	120	2.4	0.015	7×10^{-9}	3.0
		120	2.4	0.015	7×10^{-9}	8.6
511-bit pseudo-random number	49,152-bit Ramp	120	2.4	10.0	5×10^{-9}	11.1
		120	2.4	10.0	4.7×10^{-1}	not achievable

Table 3.2

The problem of choosing a suitable initial optimization method is essentially totally avoided in the case of the M^2 - code, because the bounded Digital Sum Variation obviates the need for DC-restoration (See Para 3.1.6).

3.5 EYE PATTERNS

Superposition of bits of a pseudo-random word in any code allowing transitions only at bit-cell ends results in an oscillogram resembling an eye which, in the optimum case, remains wide open. In the case of codes allowing transitions at bit-cell centers as well as ends, such transitions appear at the center of the eye, as seen in Figs. 14 and 15.

3.5.1 Test Procedure

The eye patterns observed for the three codes and the six test words, measured for five bit densities, are shown in Fig. 14 (for 30 in/s tape speed) and Fig. 15 (for 60 in/s). These patterns represent the optimized condition, i.e. zero record margin, after phase and amplitude equalization, but prior to any DC-restoration or to amplitude limiting. The amplitude scale is not uniform and was adjusted for a maximum deflection of four divisions, in each case. The time scale is constant for each of the seven figures, but was adjusted with each change of bit density, to give the display approximately constant bit length.

3.5.2 General Comments

Bit detection occurs in the uncluttered opening of the "eye", and it is of paramount importance to provide adequate noise-free decision time. The appearance of the eye is therefore generally an excellent qualitative indication of the BER to be expected.

In all cases, the amplitude of the eye pattern varies between a maximum (determined by the mid-band response of the recorder, for short run-lengths of ones or zeros) and a minimum (determined by the high-frequency response of the recorder, for flux reversals following each other very rapidly). The broadening of the zero crossings is, in general, due to the intersymbol interference, i.e. due to phase displacements resulting from flux reversals in rapid succession. In addition, noise may ride on the signal, such that

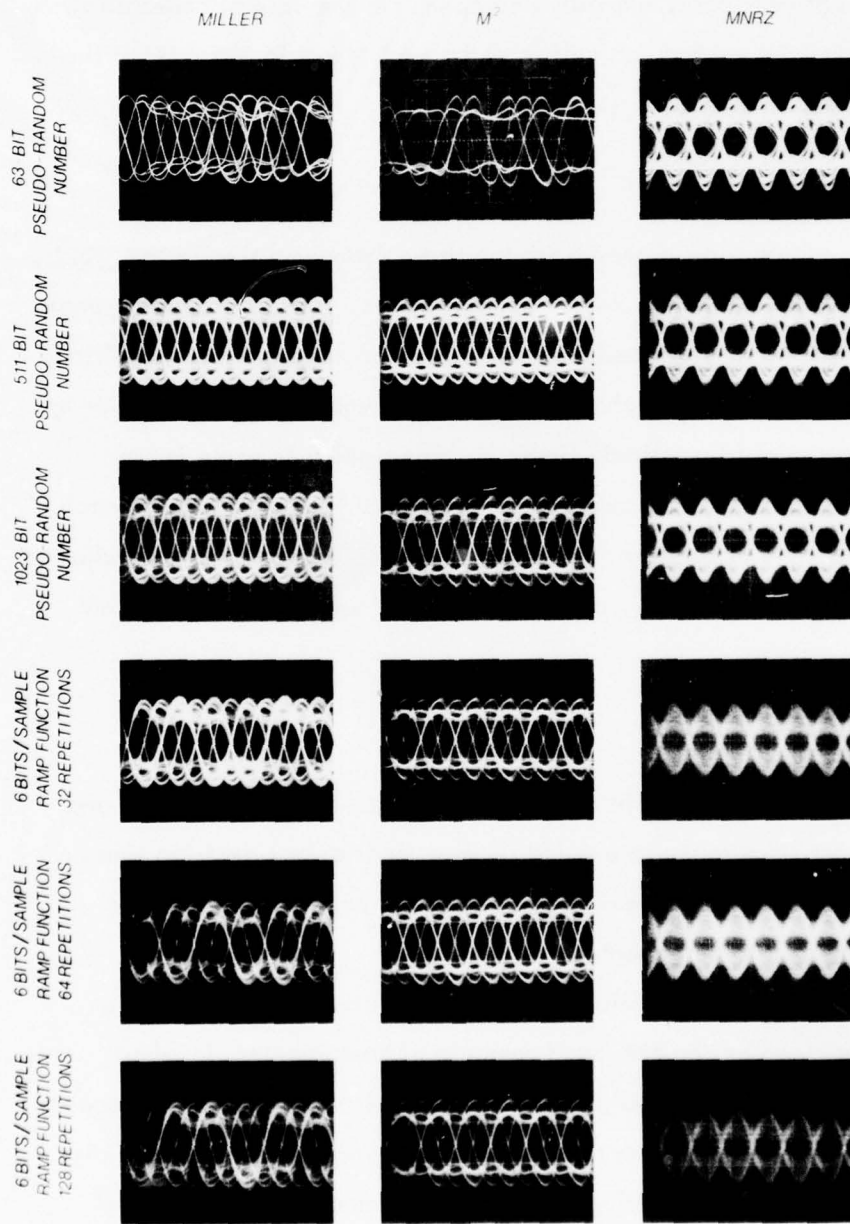

TAPE SPEED 30IPS

LINEAL BIT PACKING DENSITY 10KB/IN

FIG. 14(a) EYE PATTERNS

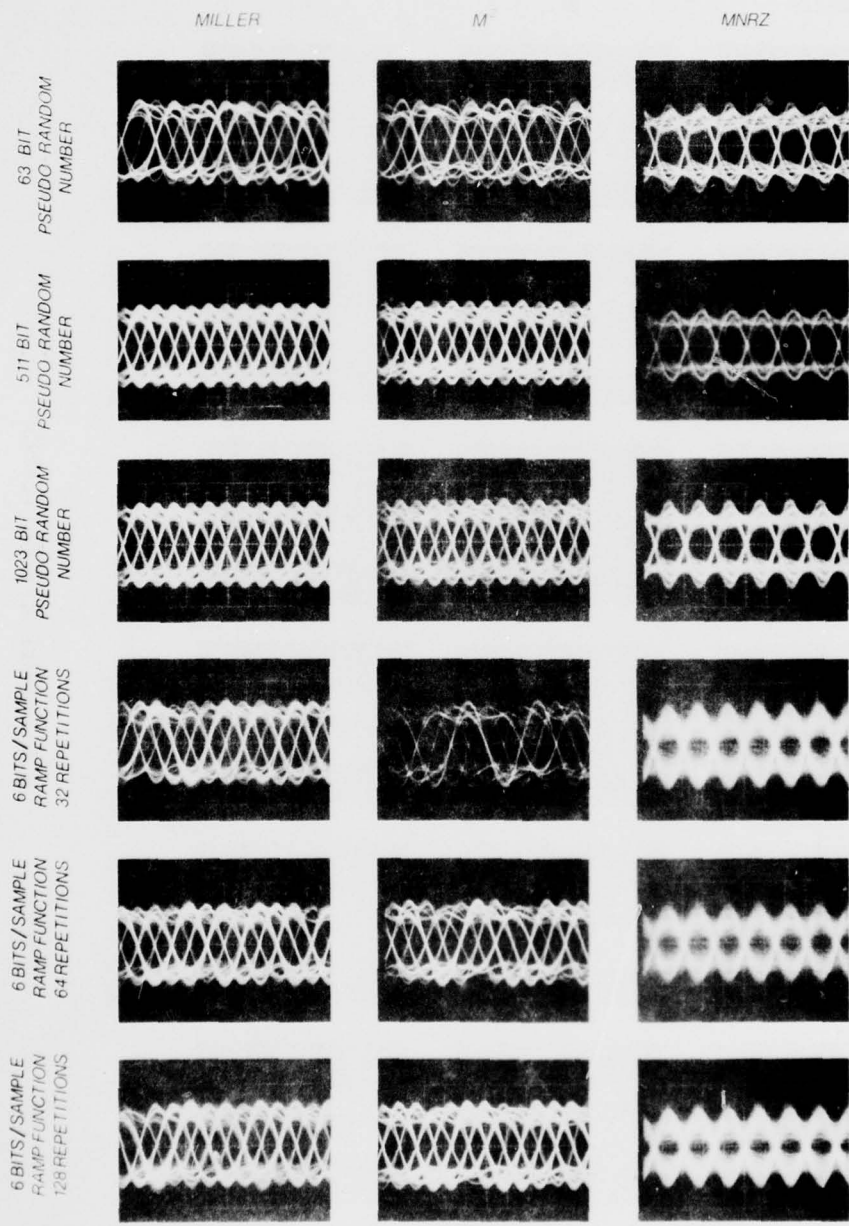

TAPE SPEED 30IPS

LINEAL BIT PACKING DENSITY 20KB/IN

FIG. 14(b) EYE PATTERNS

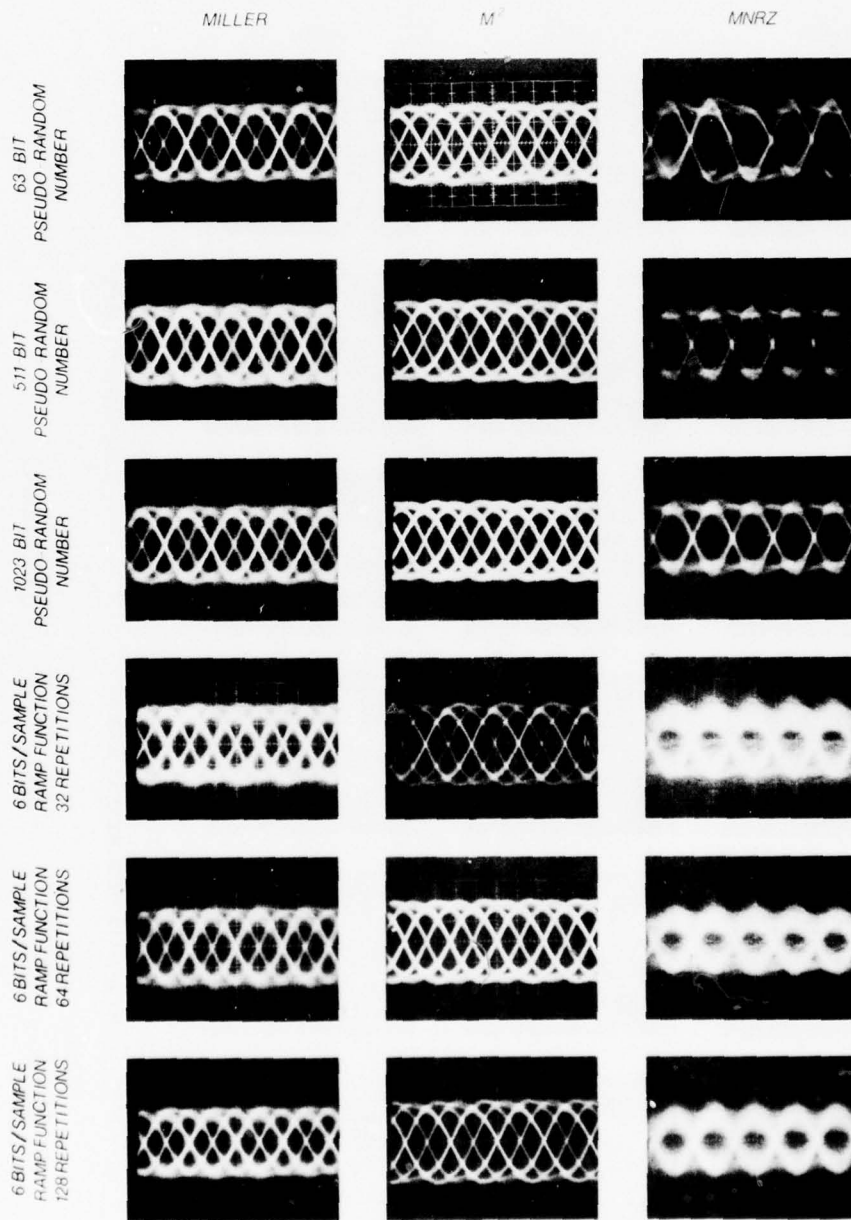

TAPE SPEED 30IPS

LINEAL BIT PACKING DENSITY 30KB/IN

FIG. 14(c) EYE PATTERNS

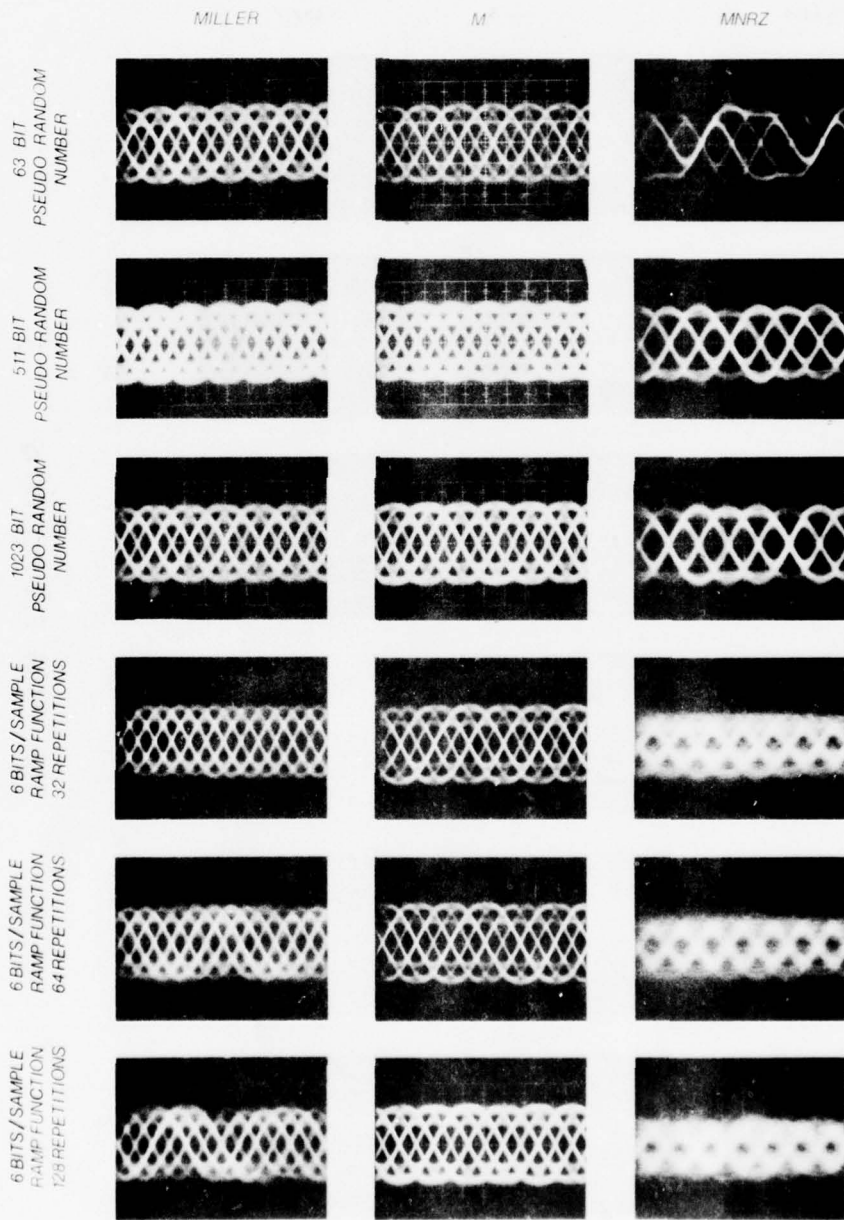

TAPE SPEED 30IPS

LINEAL BIT PACKING DENSITY 40KB/IN

FIG. 14(d) EYE PATTERNS

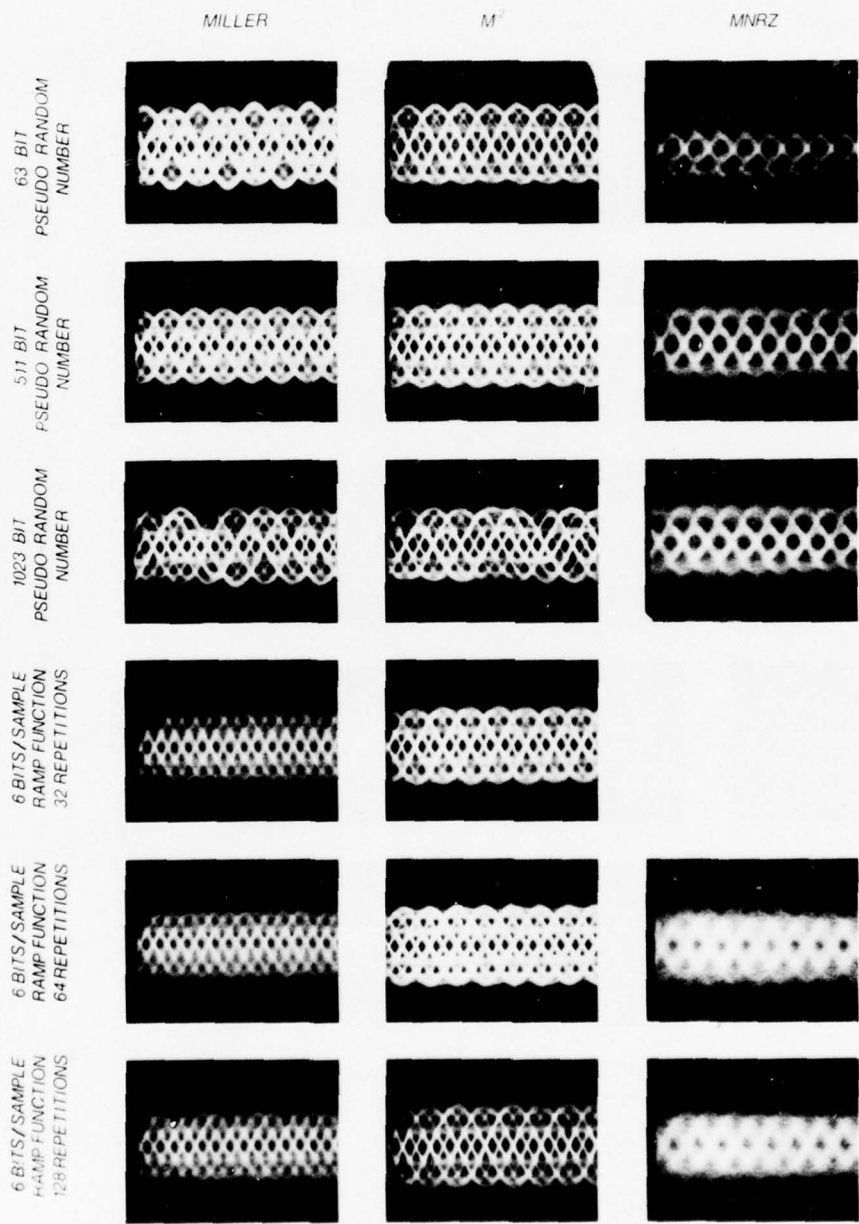

TAPE SPEED 30IPS

LINEAL BIT PACKING DENSITY 50KB/IN

FIG. 14(e) EYE PATTERNS

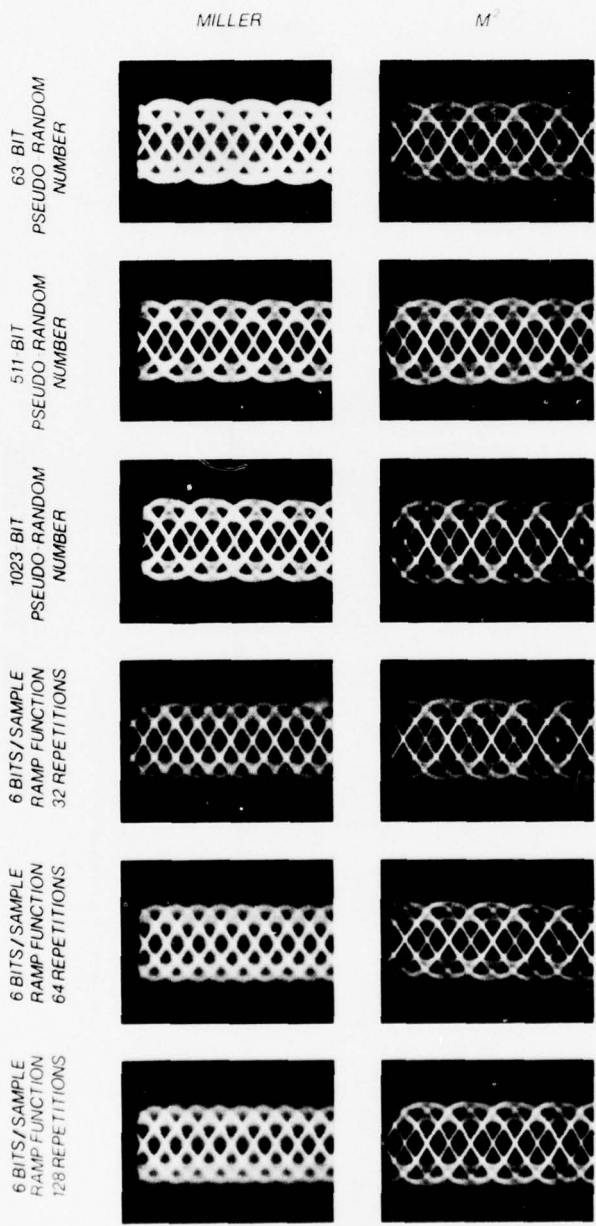

TAPE SPEED 60 IPS

LINEAL BIT PACKING DENSITY 40 KB/IN

FIG. 15(a) EYE PATTERNS

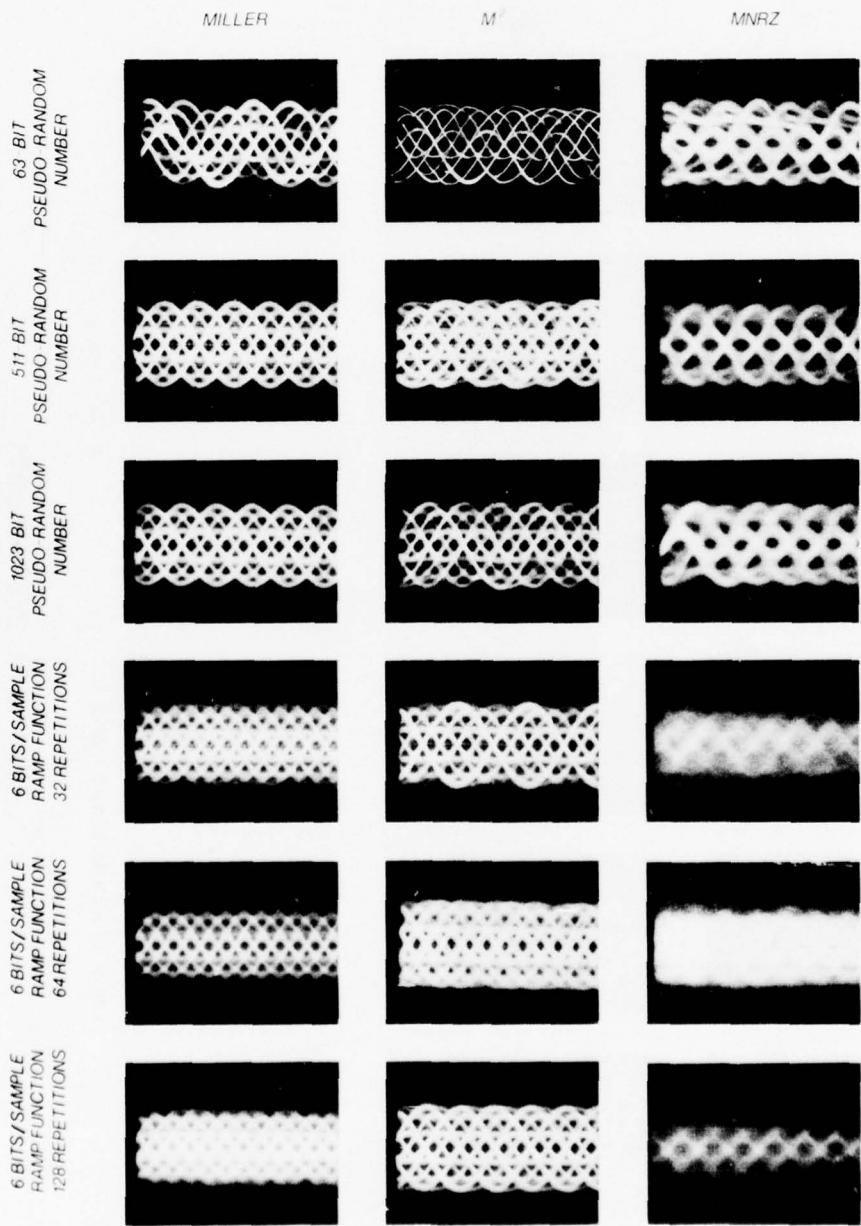

TAPE SPEED 60IPS

LINEAL BIT PACKING DENSITY 50KB/IN

FIG. 15(b) EYE PATTERNS

a lowered SNR, though seemingly compensated by higher gain is manifested by a broadening of the oscillograph traces.

3.5.3 Discussion of Results

The figures show that MNRZ should give adequate performance for pattern-free data (pseudo-random numbers) at densities up to perhaps 40 Kb/in as recorded on tape (i.e. 35 Kb/in data, plus 5 Kb/in overhead for the eighth bit). If the data are allowed to contain patterns (e.g. the sampled ramp function), performance may well become marginal even at 10 Kb/in.

The Miller code maintains a reasonably constant appearance for any test word, up to about 50 Kb/in, but degrades as bit density increases. Operation is marginal, but better than MNRZ, at 40 and 50 Kb/in.

The best appearance of eye patterns is maintained by the M^2 code, which offers a comparatively wide open decision space for all data patterns, and even at the highest bit densities tested, - a fact which is further confirmed by the BER test results shown in Figs. 12 and 13.

3.6 BIT WAVESHAPES

Oscillograms presenting the waveshapes for the three test codes, under various test words, and for bit packing densities ranging from 10 Kb/in to 50 Kb/in at 30 ips, and from 40 Kb/in to 50 Kb/in at 60 ips, are presented in Figs. 16 and 17.

3.6.1 Test Procedure

The procedure is identical to that described in Para. 3.5.1, except that for one oscillogram, i.e. that at 40 Kb/in for the M^2 -code tested with a 511-bit word, the timebase scale was erroneously doubled. However, these traces only serve to show comparative wave shapes and neither timebase nor

amplitude are assigned any particular significance. These patterns again describe the optimized (minimum BER) condition, i.e. zero record margin, and represent the signals after phase and amplitude equalization, but prior to any DC-restoration or to amplitude limiting.

3.6.2 General Comments

The oscillograms of Figs. 16 and 17 are primarily presented for the sake of completeness, and even though we were not as yet able to deduce from them any broadly applicable conclusions. In the case of pseudo-random numbers, little can be concluded due to the continually changing data content of ones and zeros. Perhaps more can be extracted from the sampled-ramp function tests, where the data pattern remains fixed and repetitive for essentially the entire duration of the recorded trace.

3.6.3 Discussion of Results

Perhaps the most obvious observation is the existence of the harmonic content at low bit rates (e.g. from 10 to 30 Kb/in at 30 in/s, i.e. from 300 to 900 Kb/s), and the more nearly sinusoidal waveform at 40 and 50 Kb/in, 30 and 60 in/s (i.e. from 1.2 to 3.0 Mb/s). This is of course easily explained by the bandwidth limitation of the recorder. We did note, however, that the presence of the harmonic, if suitably phase-equalized, resulted in reduced BER (i.e., higher record margin at given BER). For example, a 3.1 db record margin increase was possible at 30 in/s at 10 Kb/in (i.e., at 300 Kb/s) by readjustment of the phase of the third harmonic, as evidenced by delaying the peak of the distorted wave relative to the fundamental.

From these observations we conclude that an improvement in record margin (for a given BER) or in BER (for a given record margin) could be achieved through incorporation of a phase correction circuit capable of providing essentially constant phase delay.

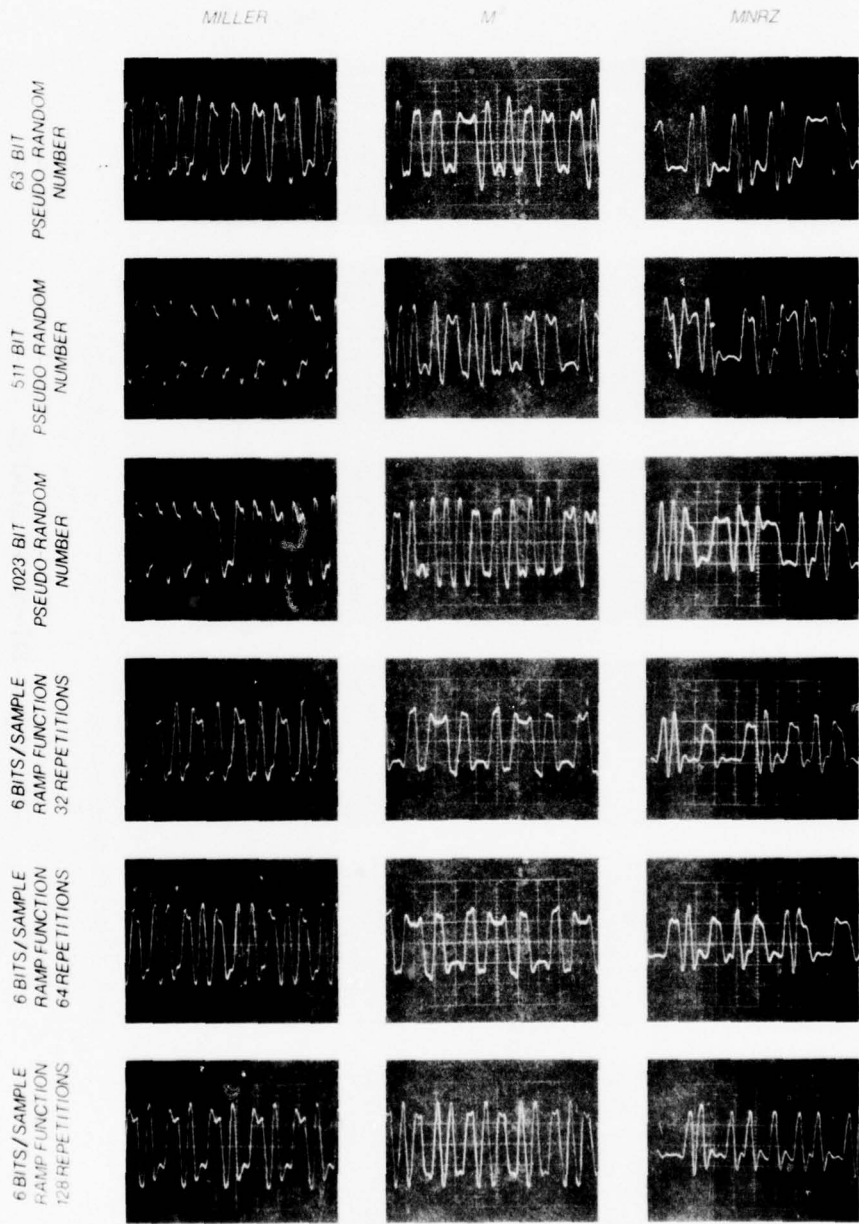

TAPE SPEED 30IPS

LINEAL BIT PACKING DENSITY 10KB/IN

FIG. 16(a) BIT-WAVE SHAPES

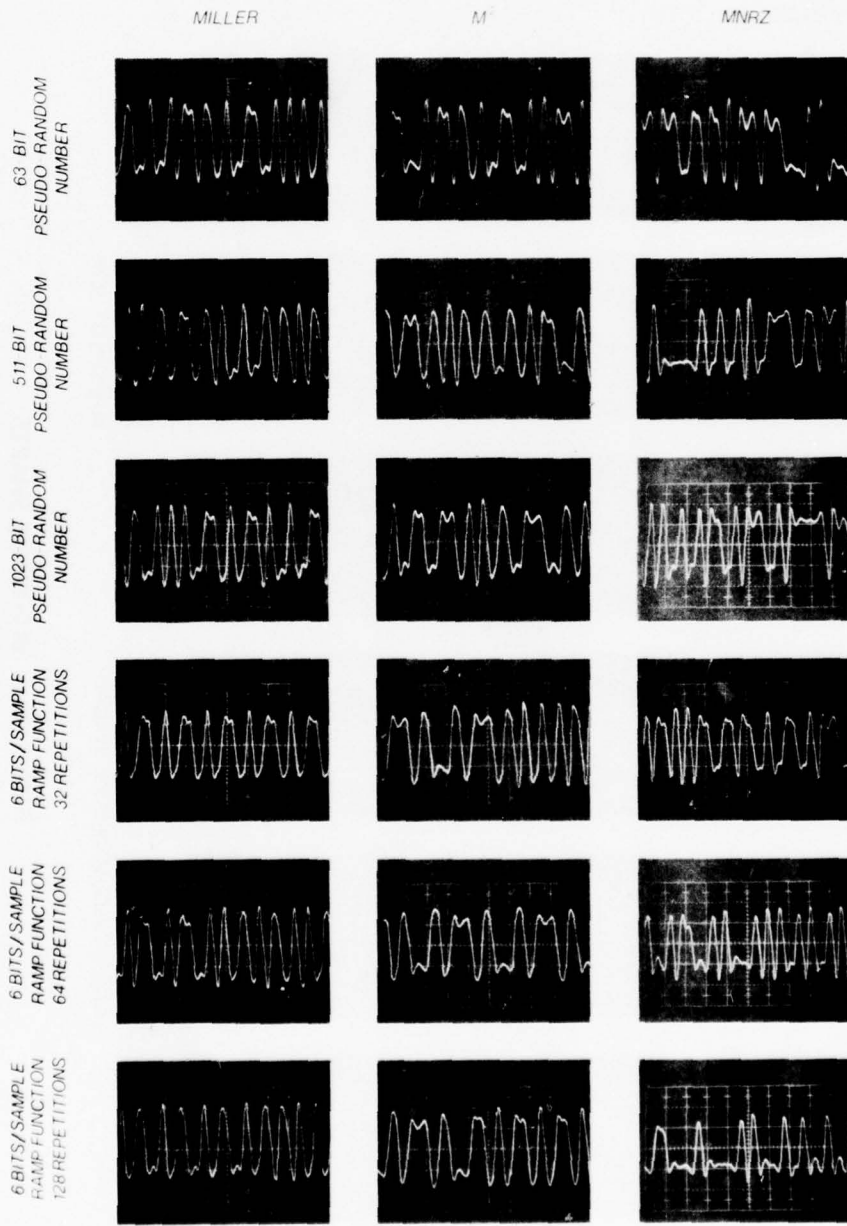

TAPE SPEED 30IPS

LINEAL BIT PACKING DENSITY 20Kb/IN

FIG. 16(b) BIT-WAVE SHAPES

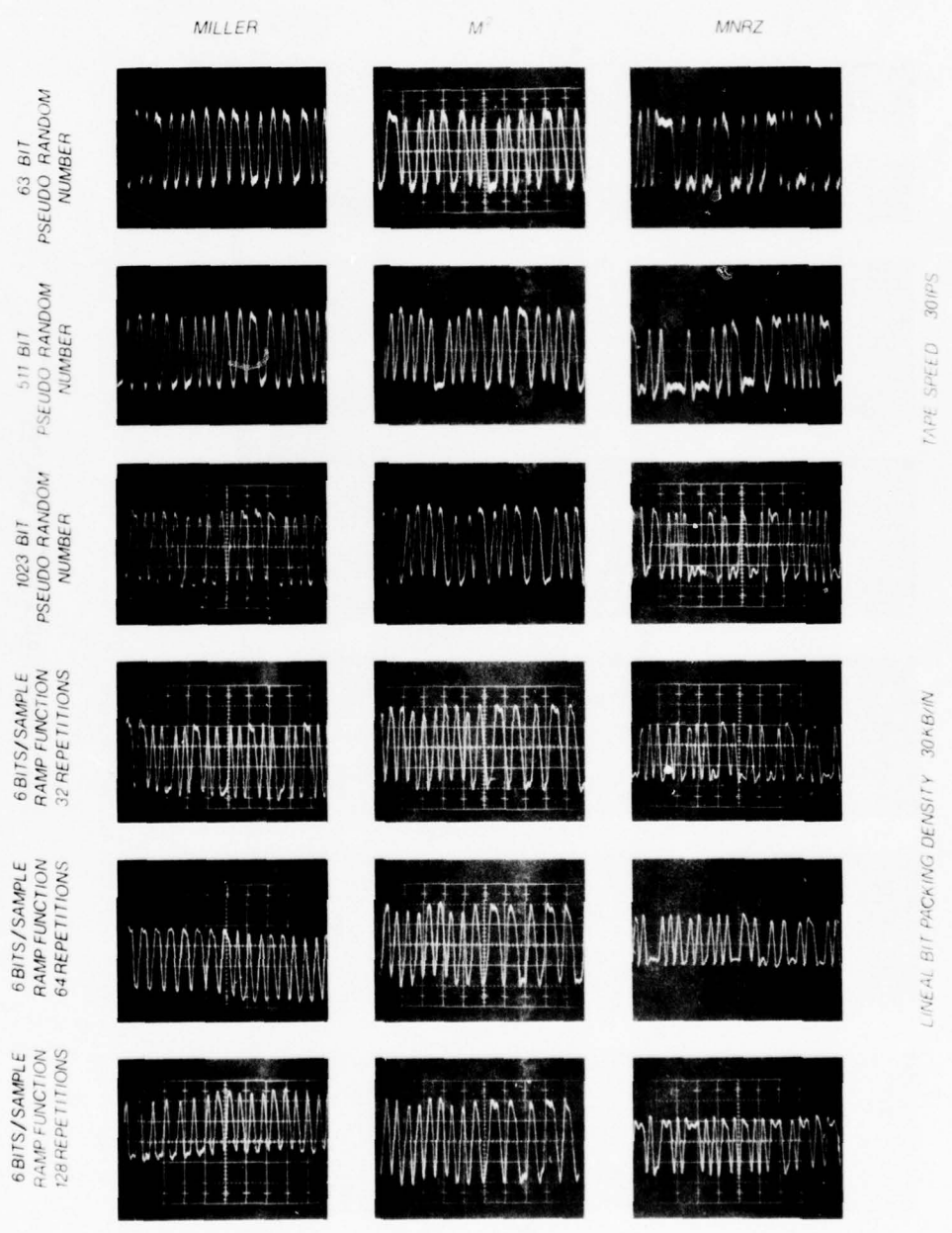

TAPE SPEED 30IPS

LINEAL BIT PACKING DENSITY 30A.B./IN

FIG. 16(c) BIT-WAVE SHAPES

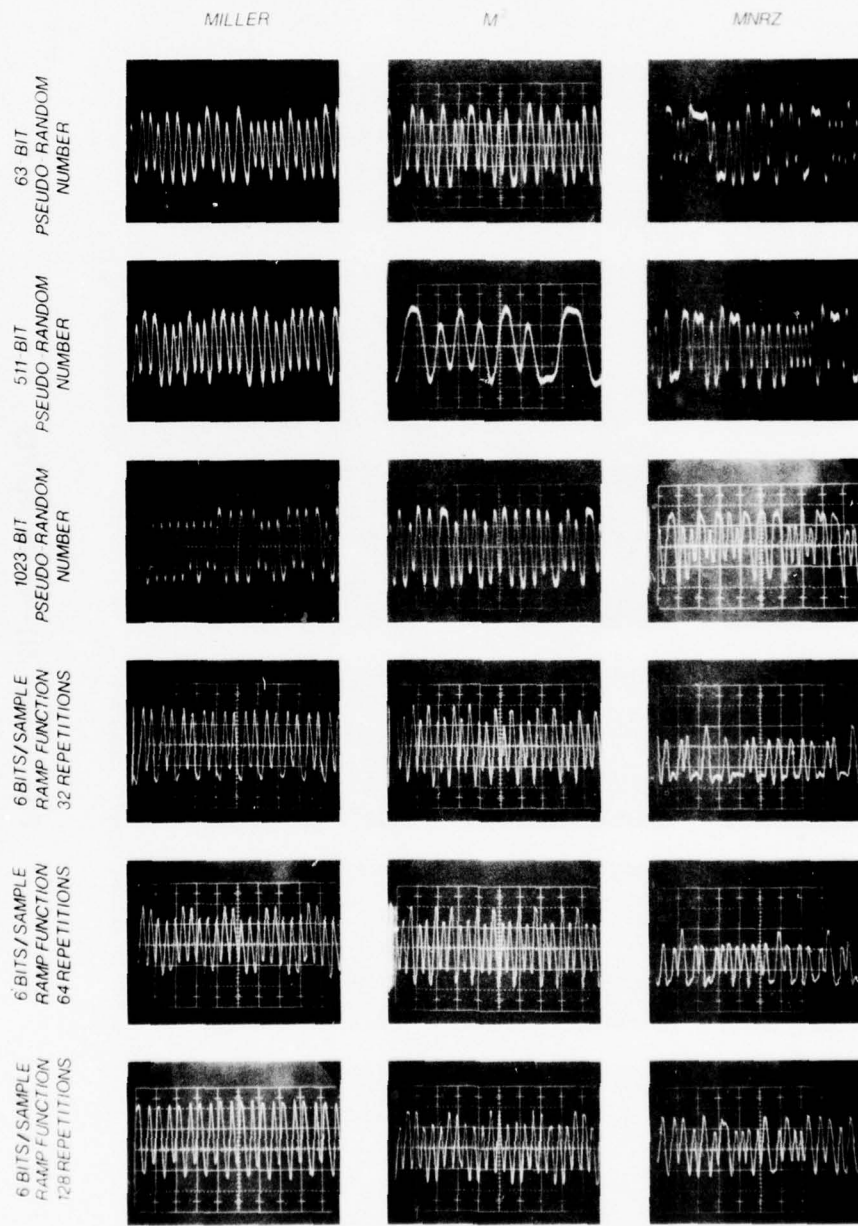

TAPE SPEED 30IPS

LINEAL BIT PACKING DENSITY 40KB/IN

FIG. 16(d) BIT-WAVE SHAPES

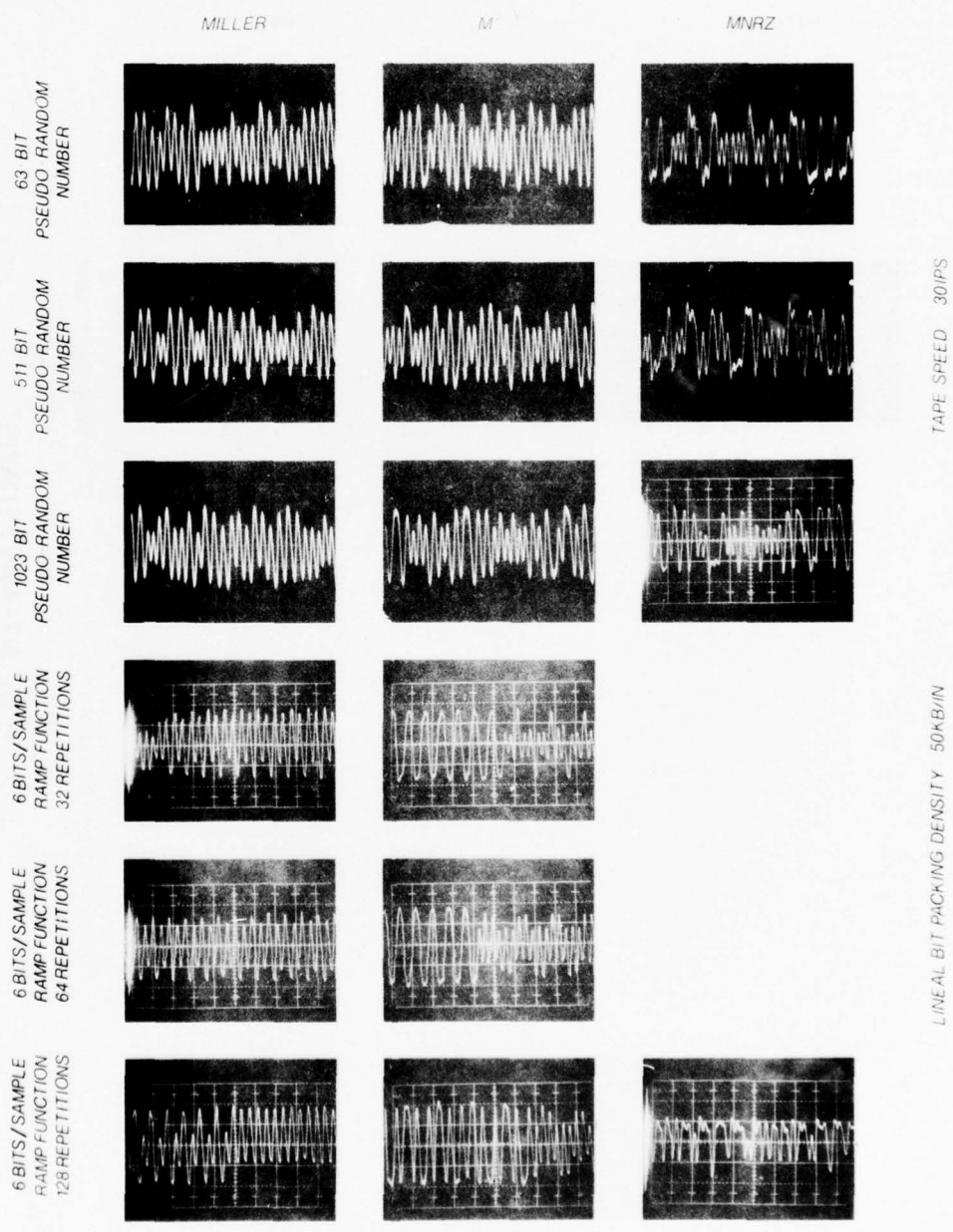

FIG. 16(e) BIT-WAVE SHAPES

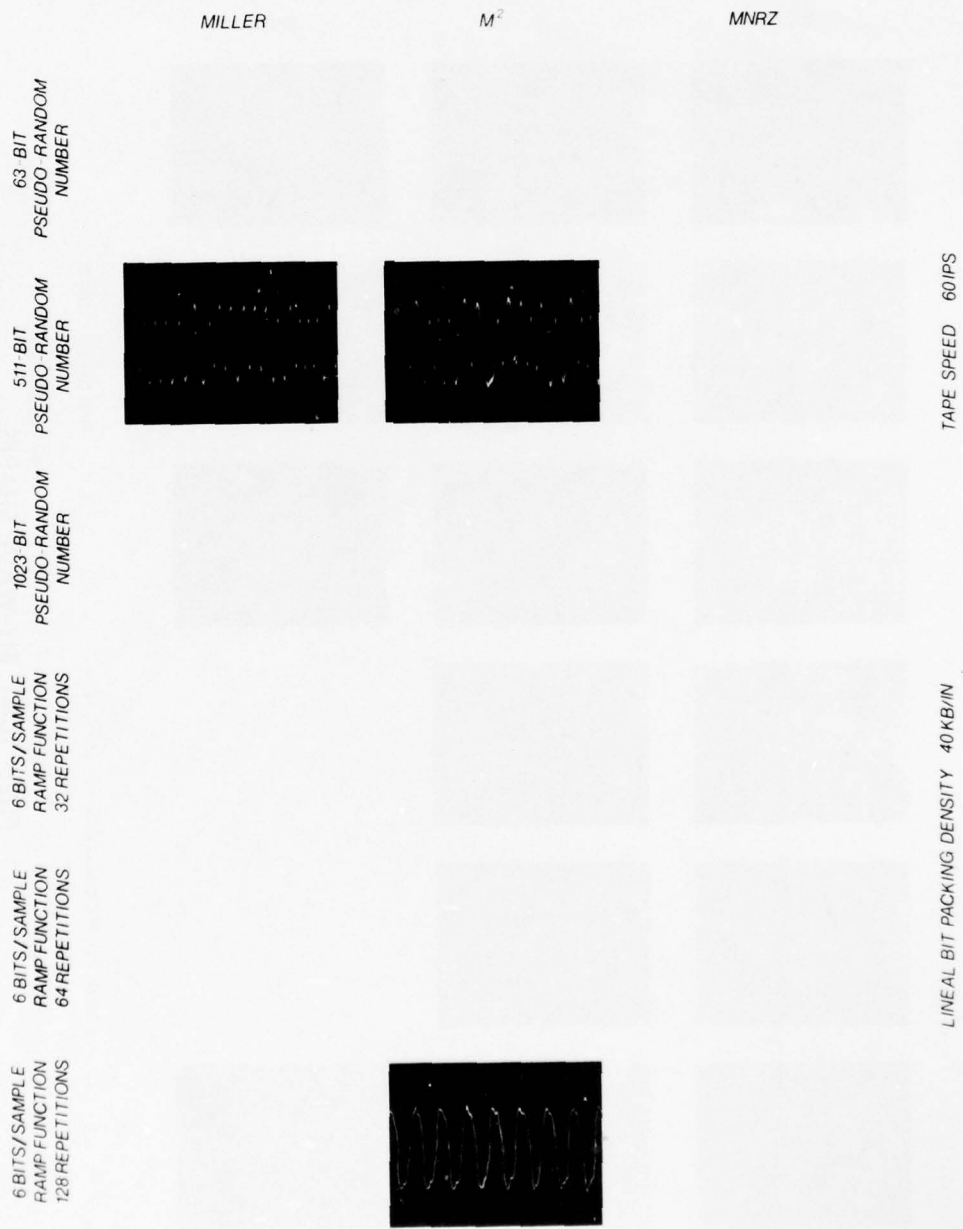
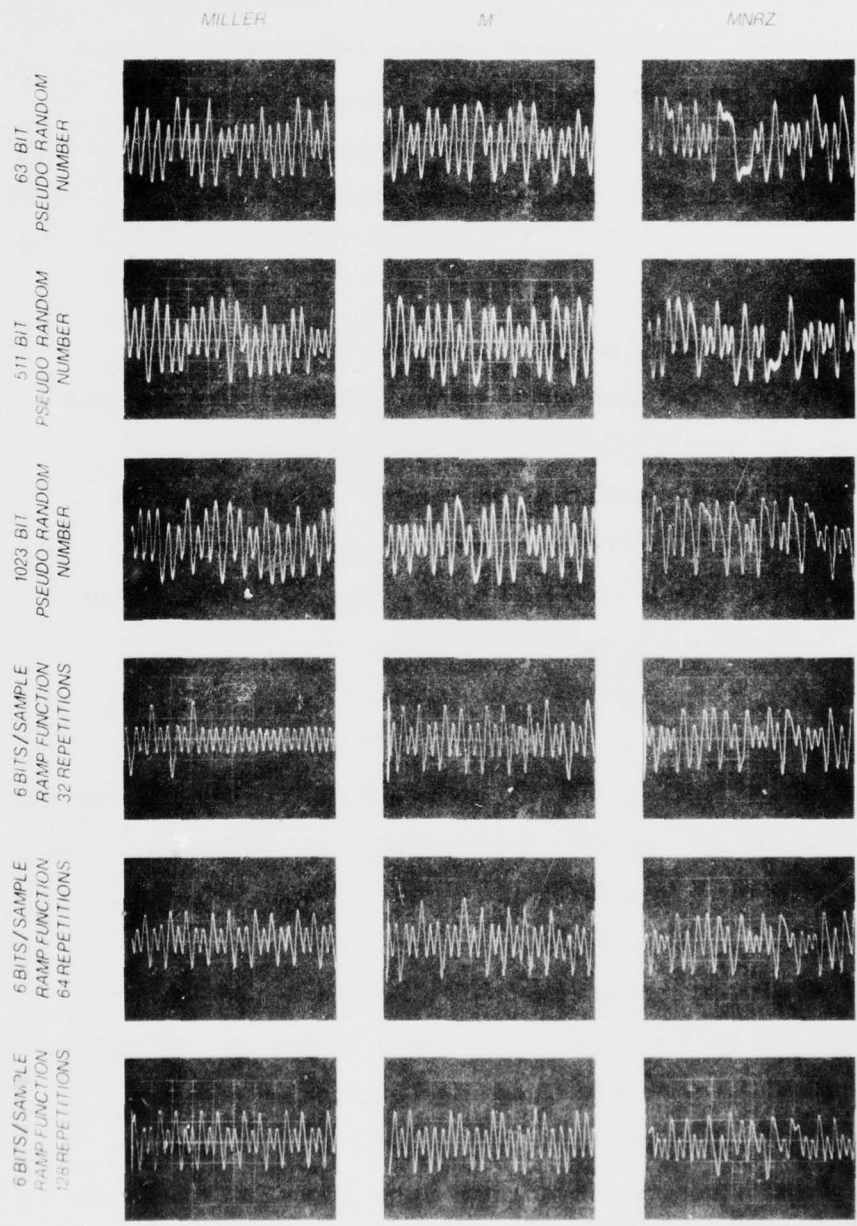

FIG. 17(a) BIT-WAVE SHAPES



TAPE SPEED 60 IPS

LINEAL BIT PACKING DENSITY 50 KB/IN

FIG. 17(b) BIT-WAVE SHAPES

3.7 ZERO-LINE DRIFT

The zero-line drift has been identified as a major BER source, if not perhaps even the major source. The effect becomes particularly pronounced when other factors, such as bit-packing density, or bit rate, render the system more sensitive to degradation. Minimization of zero-line drift therefore becomes a major objective in the selection of a recording code. The oscillograms of Figs. 18 and 19 display the zero-line drift over the six bit-packing densities, for the three codes, each tested under six test-word conditions.

3.7.1 Test Procedure

The test procedure is again the same as described in Para 3.5.1: All patterns represent the optimized (zero record-margin) condition after amplitude and phase equalization, but prior to DC-restoration and amplitude limiting. The amplitude scale was adjusted in each case, for constant vertical deflection for all oscillograms. The time (horizontal) scale also was readjusted so as to present several cycles of test words in each oscillogram. Thus, there is no definite relation from one oscillogram to the next, for either scale.

3.7.2 General Comments

The oscillograms of Figs. 18 and 19 are similar to those of the waveshapes described earlier, except that the time scale is substantially more compressed. Gross periodicities of the patterns result from the lengths of the test word used. Thus, the 63-bit word shows patterns that repeat comparatively soon, whereas the ramp-function test with 128 repetitions, representing a $6 \times 64 \times 128 = 49,152$ -bit word, requires a longer time period and therefore displays fewer "cycles" per oscillogram.

As in the case of the eye patterns, the effect of recorder bandwidth limitations is also evident: Bit sequences requiring response in midband show the largest amplitudes, whereas sequences with long runs without transition experience the effects of poor low-frequency response, and transitions in rapid succession result in low amplitude due to limited high-frequency response.

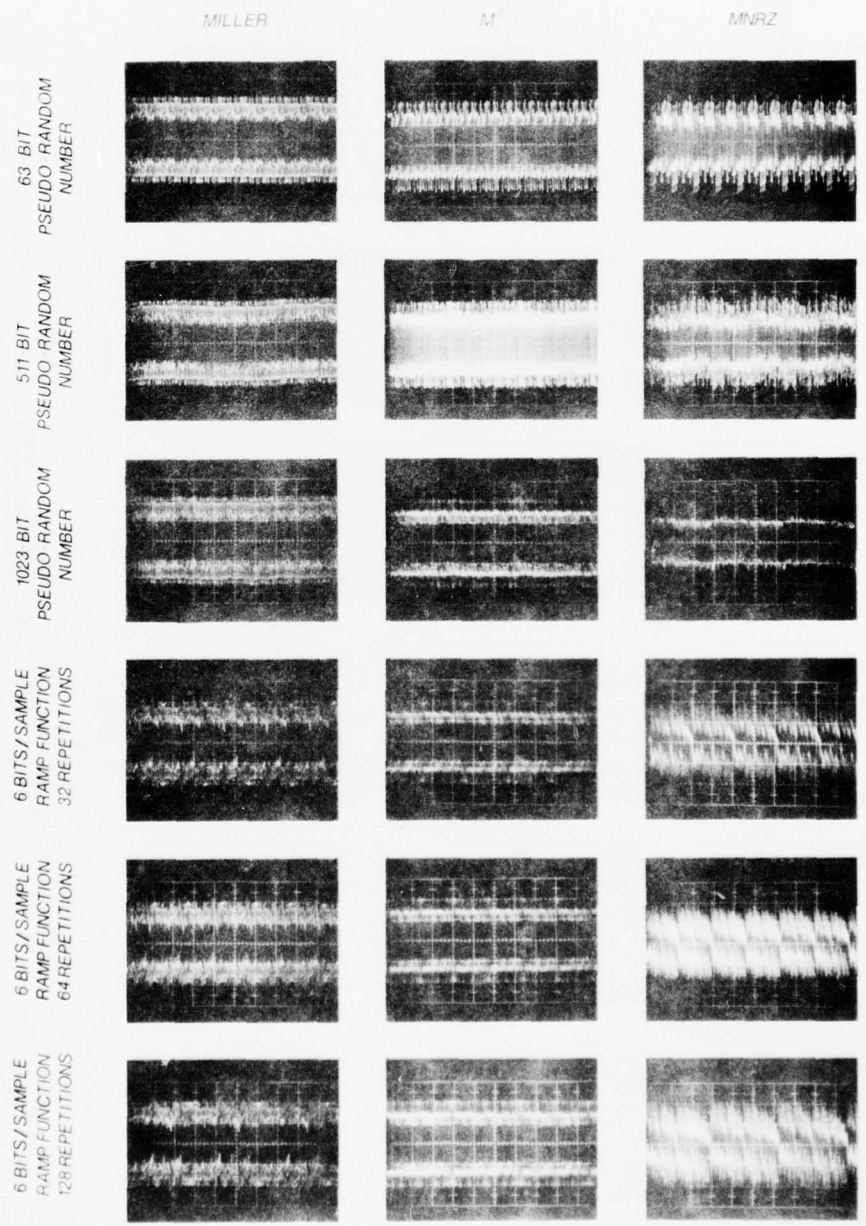

TAPE SPEED 30 IPS

LINEAL BIT PACKING DENSITY 10KB/IN

FIG. 18(a) ZERO-LINE DRIFT

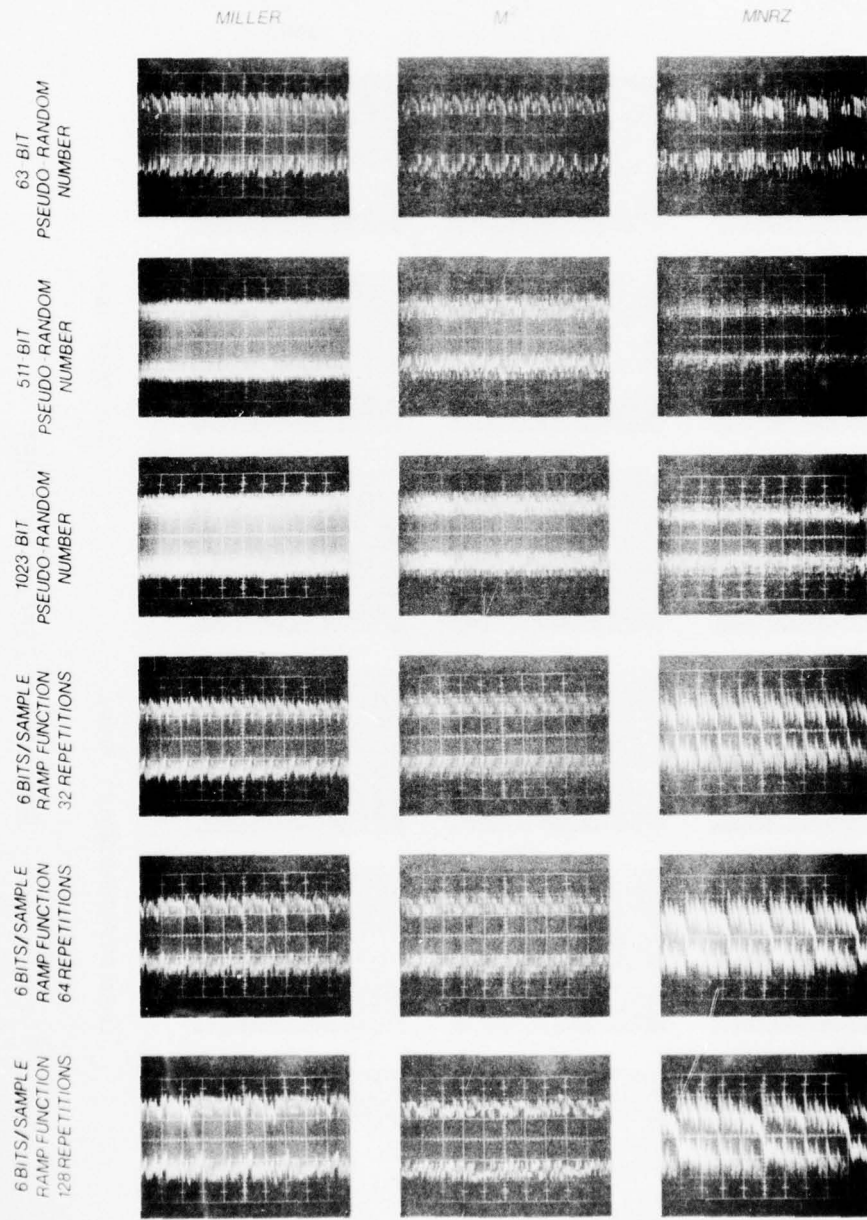

TAPE SPEED 30IPS

LINEAL BIT PACKING DENSITY 20KB/IN

FIG. 18(b) ZERO-LINE DRIFT

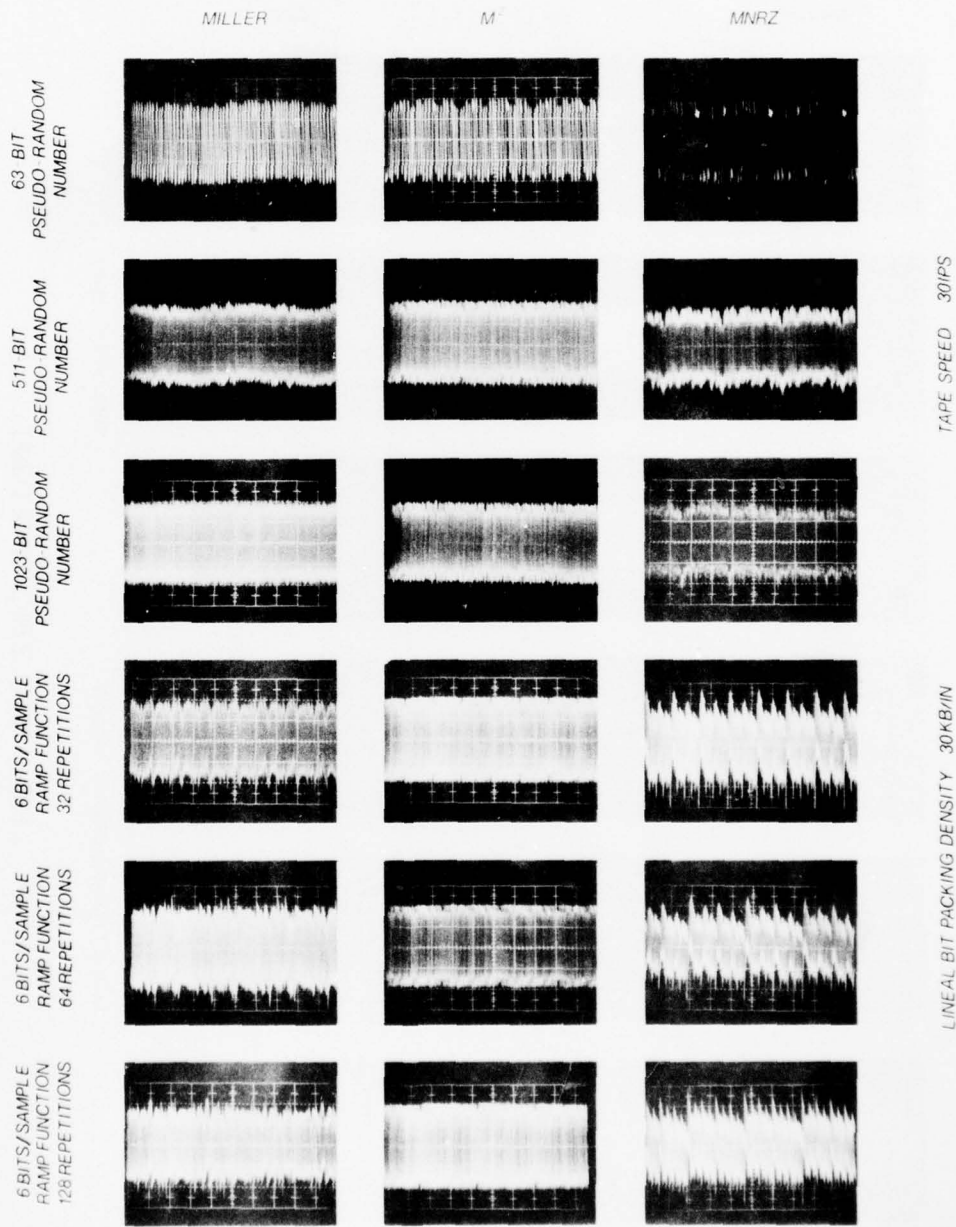
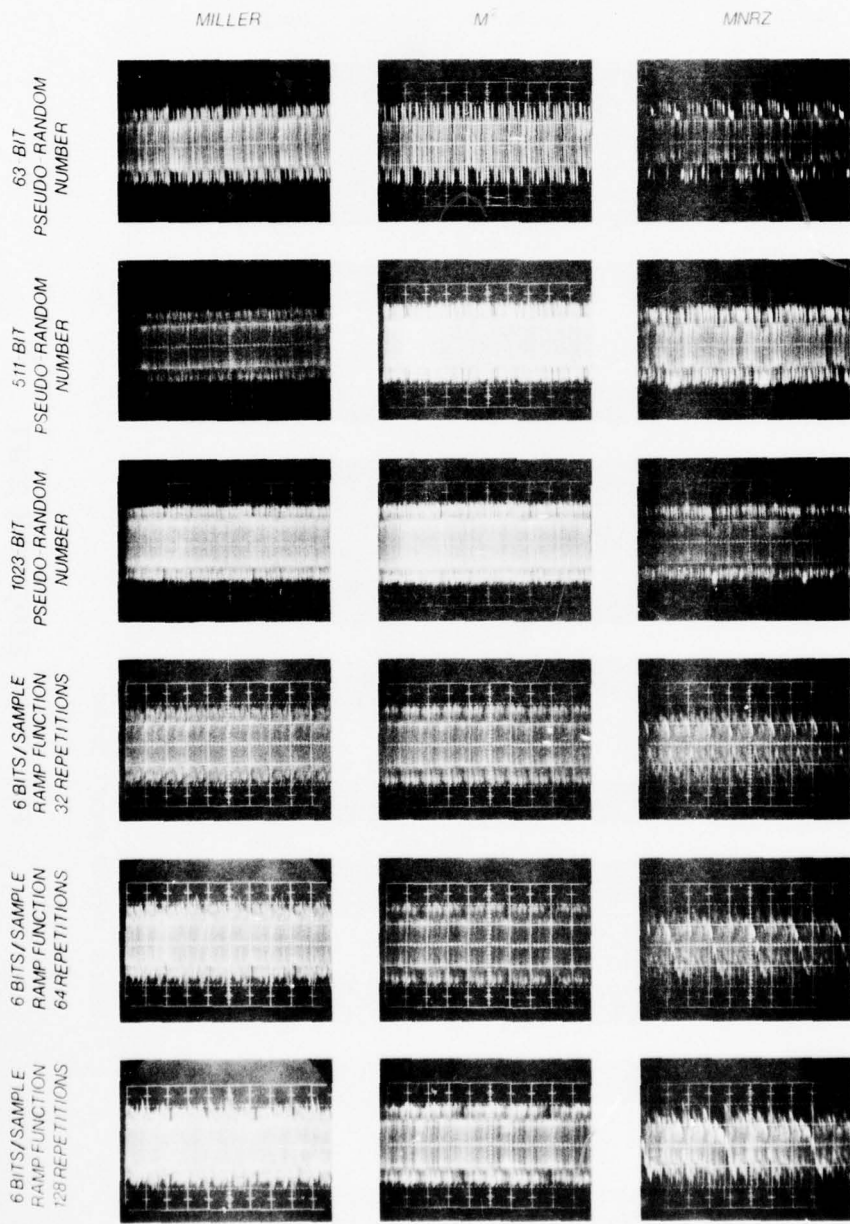

FIG. 18(c) ZERO-LINE DRIFT



TAPE SPEED 30IPS

LINEAL BIT PACKING DENSITY 40KB/IN

FIG. 18(d) ZERO-LINE DRIFT

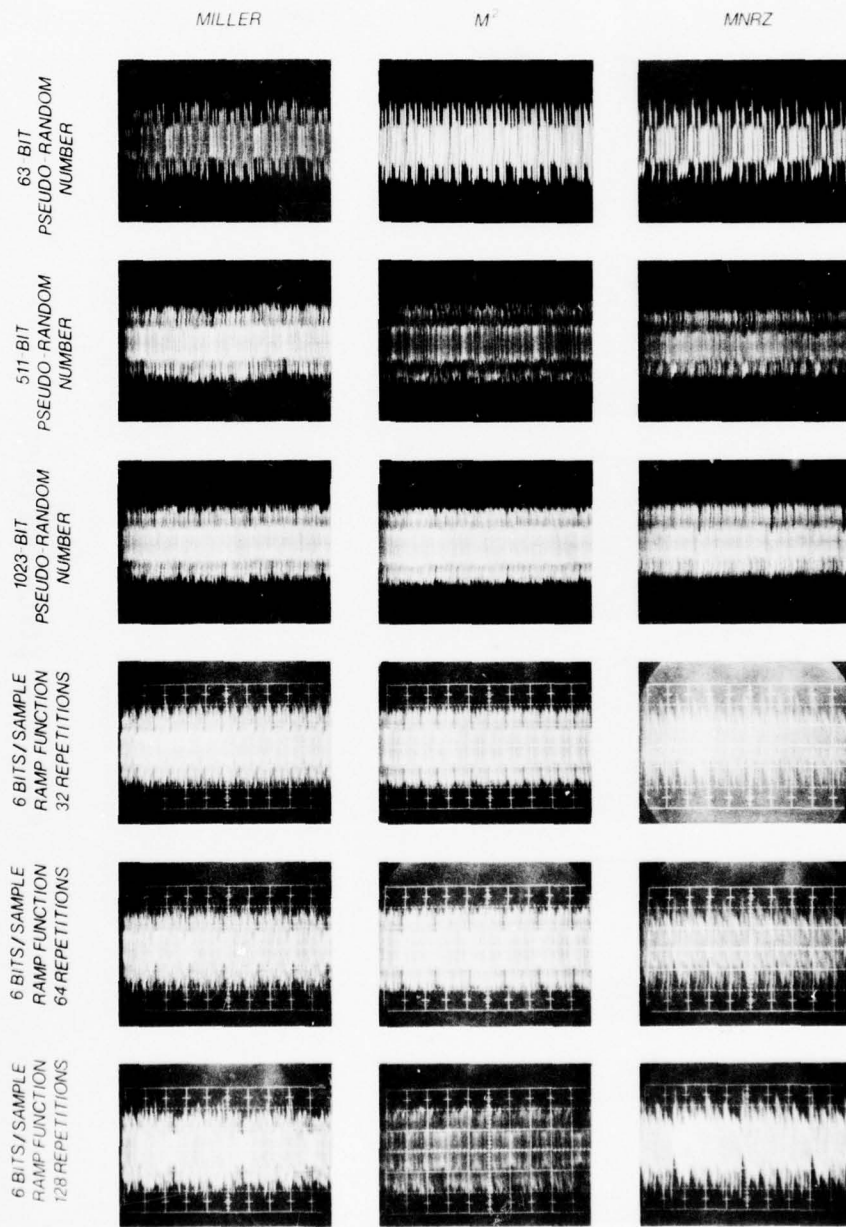

TAPE SPEED 30IPS

LINEAL BIT PACKING DENSITY 50KB/IN

FIG. 18(e) ZERO-LINE DRIFT

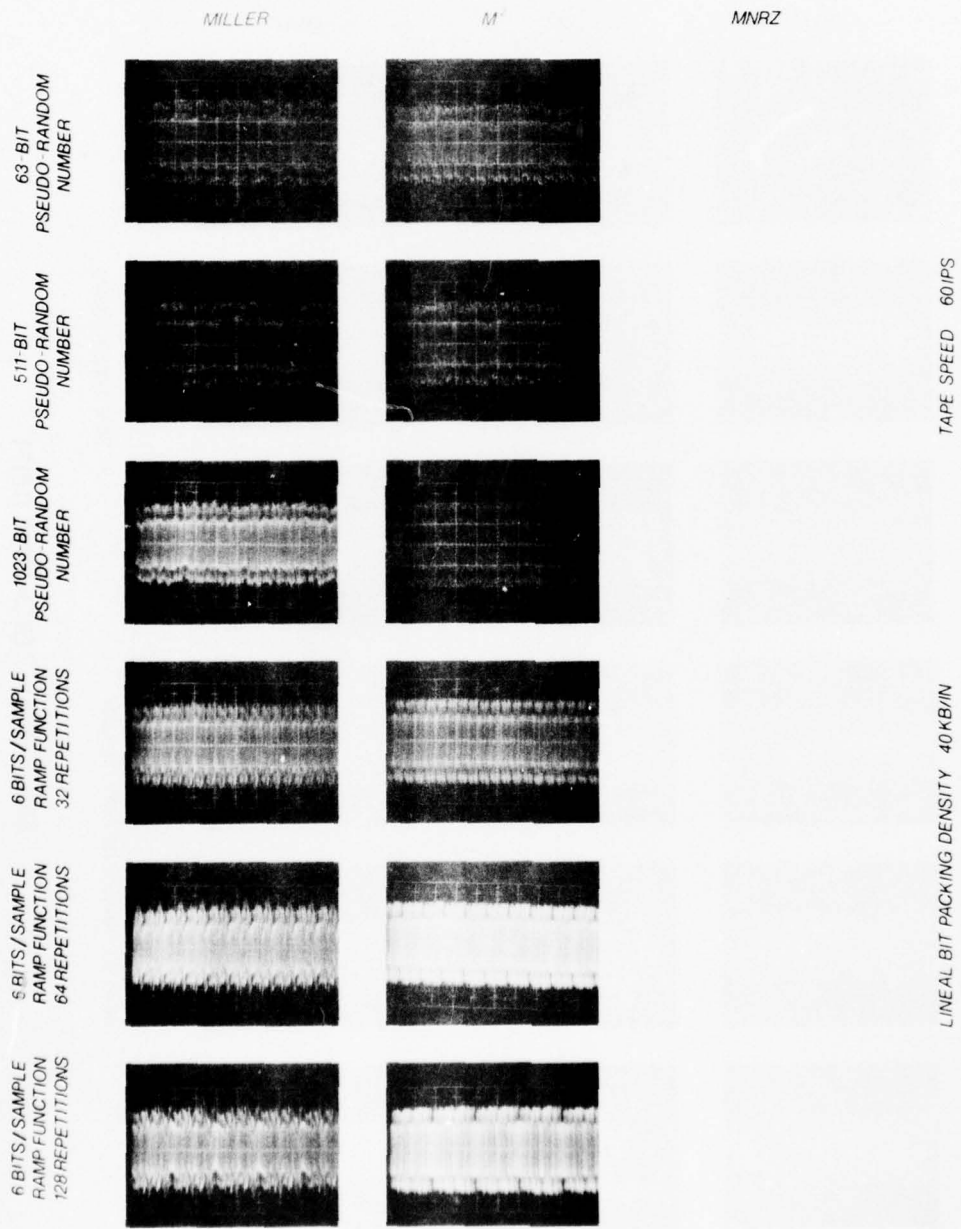
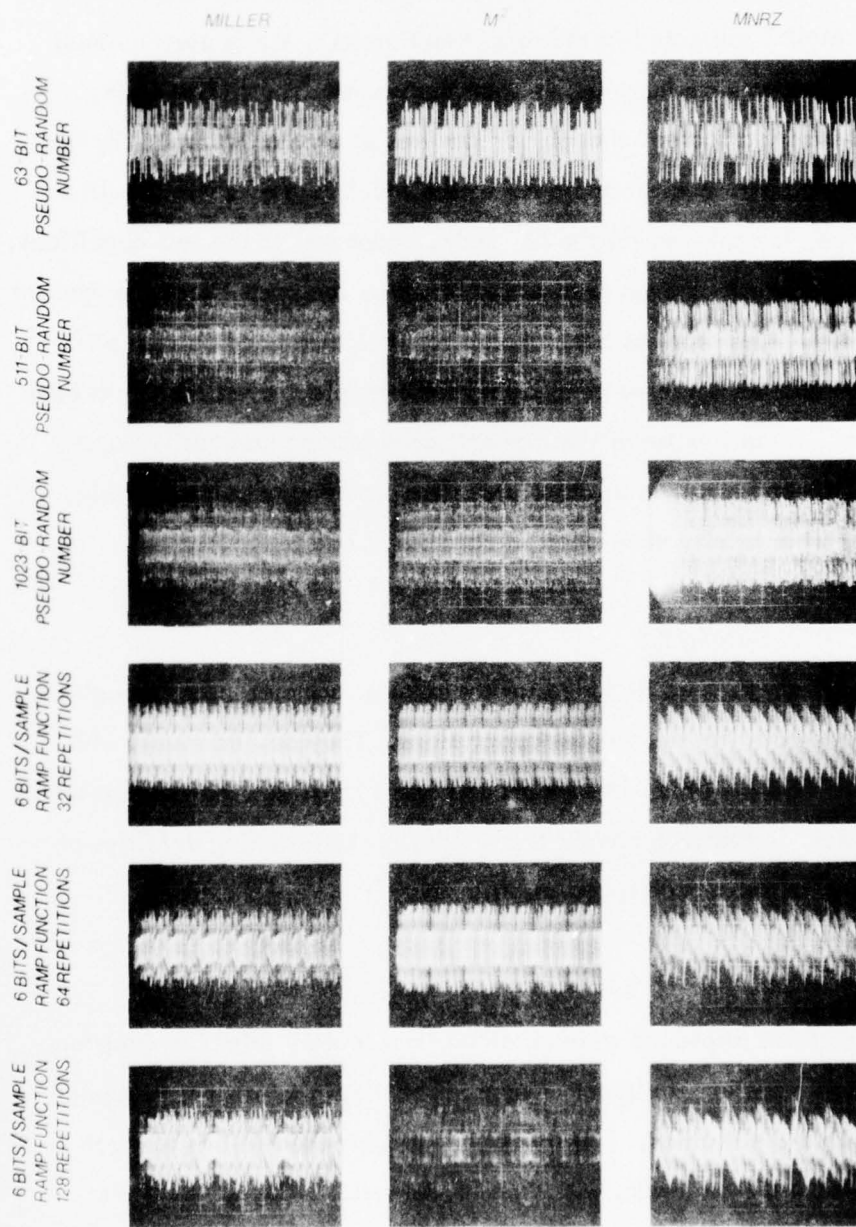

FIG. 19(a) ZERO-LINE DRIFT



TAPE SPEED 60 IPS

LINEAL BIT PACKING DENSITY 50KB/IN

FIG. 19(b) ZERO-LINE DRIFT

3.7.3 Discussion of Results

The effect of limited low-frequency response is evidenced by the inability of the recorder to maintain the straight lines in the centers of the oscillograms, as the average values of the waveforms. This effect is particularly deleterious for MNRZ subjected to the ramp function test, but is even evident for tests with pseudo-random numbers, in some instances. The Miller code, similarly, is adversely affected, though perhaps less so on the average. By far the best results, i.e. the nearest approach to the ideal case of a straight-line waveform average, is achieved for the M^2 code, under any of the test conditions.

Zero-line drift is a cause of errors for these reasons: If, at the moment of detection, the DC-restorer has been unable to lift a displaced pattern sufficiently, a "one" will be detected as a "zero," for example. Even if DC has been partially restored, a noise pulse at the moment of detection can easily cause incorrect detection and result in a bit-error. (The problems of suitable design of a DC-restorer were briefly mentioned in Para 3.1.7 and 3.1.8.)

3.8 SPECTRAL DENSITIES

These displays were included for the sake of completeness, though we cannot at this time point to meaningful conclusions. They do, however, aid the interpretation of other data, in some modest way. Fig. 20 shows the results for the three codes, tested with the six test words, for bit-packing densities of 30, 40 and 50 Kb/in and a tape speed of 30 in/s.

3.8.1 Test Procedure

The patterns displayed were obtained immediately after the encoder, and they therefore represent the spectral content of the signal as it is presented to the direct-record electronics. The spectrum analyzer used in this test run was a Hewlett Packard instrument, with mainframe model 140S, RF-Section model 8553L, and IF Section model 8552A. The horizontal scale represents frequency and was adjusted to fill the screen, but remained constant for all

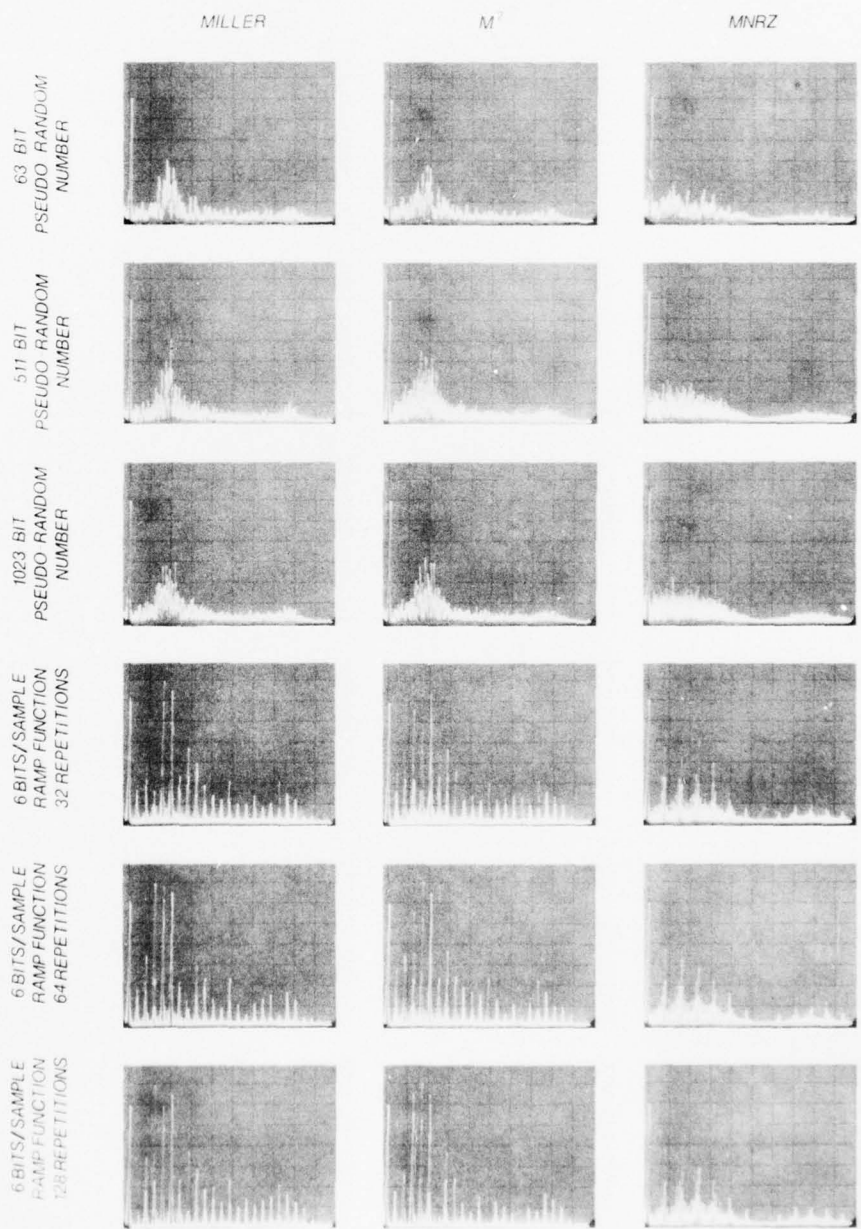

TAPE SPEED 30IPS

LINEAL BIT PACKING DENSITY 30KB/IN

FIG. 20(a) SPECTROGRAMS

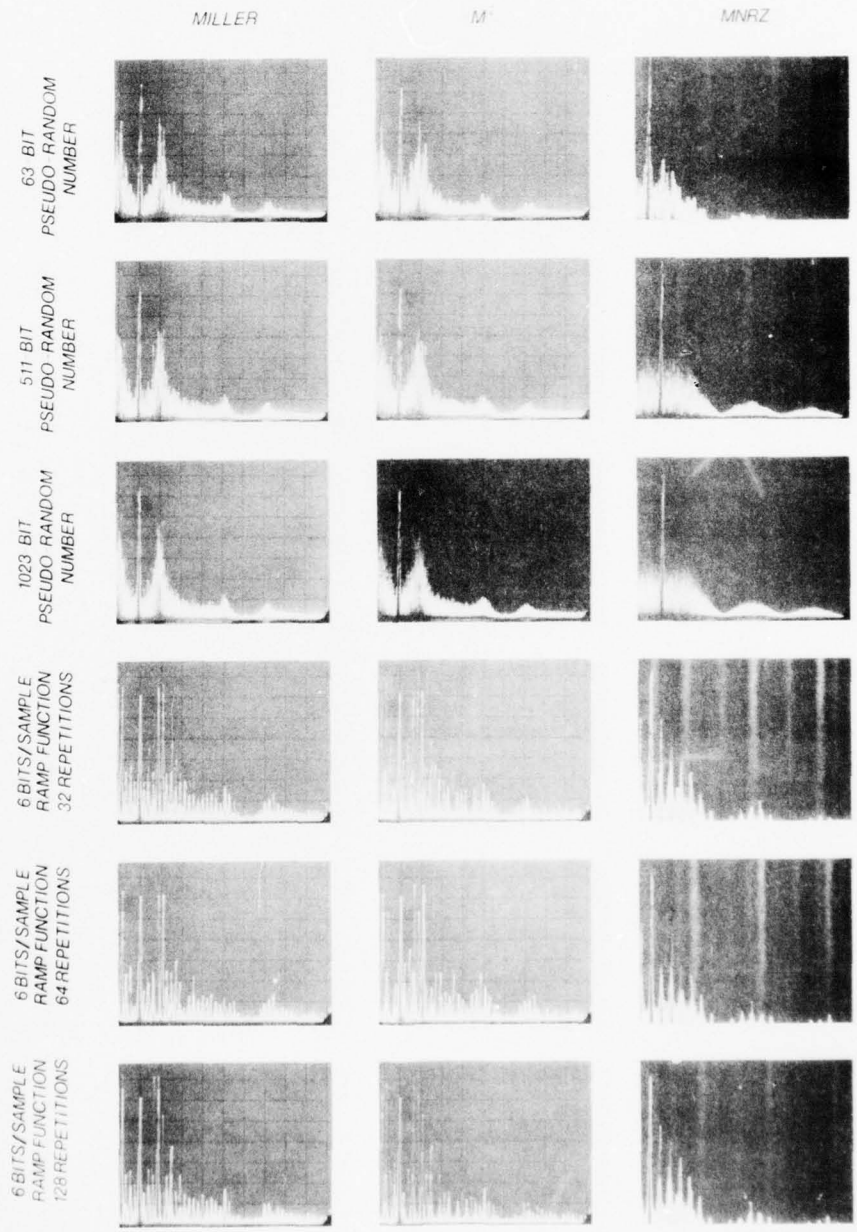

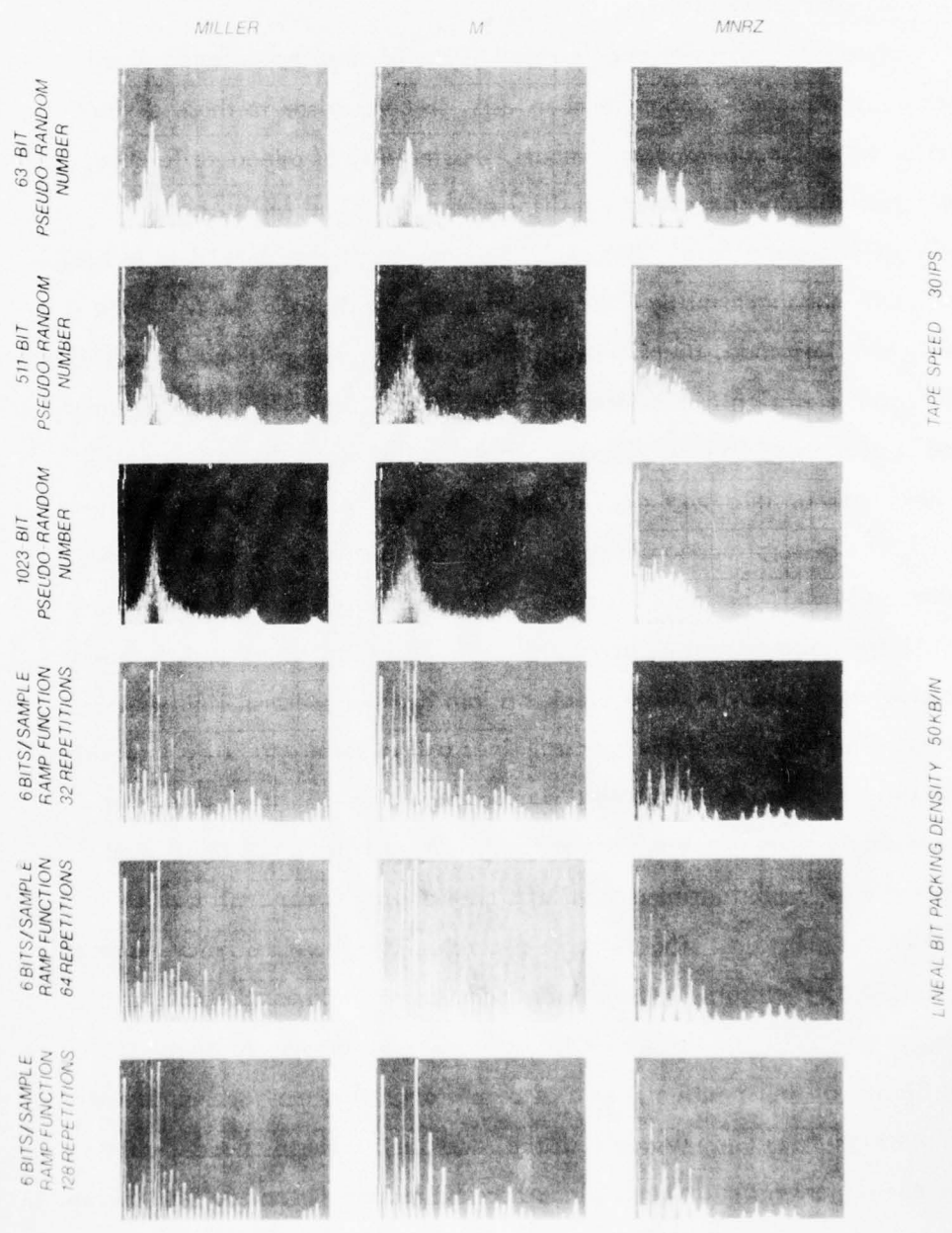

FIG. 20(c) SPECTROGRAMS

spectrograms for a given bit packing density. The vertical (amplitude) scale was arbitrary, so that no quantitative relation can be established from spectrogram to spectrogram.

3.8.2 Discussion of Results

Probably the most noticeable result is the general appearance of all spectrograms of the pseudo-random number tests, in comparison to those of the ramp-function test: Pseudo-random numbers, particularly of adequate lengths, display the classical power spectral densities of the NRZ and Miller codes discussed in the literature (e.g., Ref. 3.1); we note here, that MNRZ is an NRZ-code, despite its enhancement by the addition of extra bits, and the M^2 -code is essentially a Miller code, despite its different encoding algorithm. Nonetheless, we further note the erosion of the ideal spectral distribution, when the "random" word becomes as short as 63 bits. Experience shows that even shorter words will cause further break-up into more discrete spectral lines, as may well be anticipated. Still, the general appearance, i.e. the envelope of the spectral lines, follows adequately well the ideal distribution for a truly random bit sequence.

Altogether different observations are in order for the test words based on the sampled ramp-function. The break-up into distinct spectral lines is at once evident. The location of the spectral lines can to some extent be established from the known periodicities of the data word and its own repetition rate, but such analysis would seem to serve little purpose. What is far more significant is the fact that a very substantial amount of signal energy is concentrated at the low end of the spectrum. The demands placed on the low-frequency response of the recorder are, therefore, substantially more severe than for the case of pseudo-random words. In addition, we find a significant amount of energy in the second "lobe" of the spectrum, - a response range that may be suppressed by the limited high-frequency response of the recorder, at the higher bit-rates. These different response requirements placed on the recorder, tend to lend further

AD-A037 410

AMPEX CORP REDWOOD CITY CALIF
STUDY, TESTS, AND EVALUATION FOR
JAN 77 C F SPITZER, T A JENSEN, J M UTSCHIG

WIDEBAND HIGH-DENSITY DATA ACQ--ETC(U)
F33615-75-C-1192

F/G 14/3

UNCLASSIFIED

EP-7356

AFAL-TR-76-115

NL

2 OF 2

AD
A037410



END
DATE
FILMED
5-77

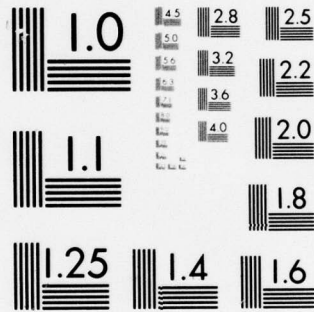

MICROCOPY RESOLUTION TEST CHART
NATIONAL BUREAU OF STANDARDS-1963-A

credence to the claim that for digitized analog signals the ramp-function test is therefore often more appropriate to the final use of the system than the test with pseudo-random numbers.

3.9 CONCLUSIONS FROM THE CODE COMPARISON TESTS

The inability of the recorder to reproduce very low frequencies was found to be an even more severe problem for HBR recording in general, than we had originally anticipated. This is illustrated in Figs. 21, 22 and 23, which illustrate the responses for the Miller - code, the M^2 - code, and MNRZ, respectively. Within experimental error, the Miller and M^2 codes show fairly close grouping, whether tested by pseudo-random number or by repeated digitized ramp function samples. The reason is found in the run-length limit of these codes, which obviates the need for DC-response. (The M^2 - code, being DC - free, requires no DC restorer, in any case.) MNRZ shows a wide spread, since its digital sum variation is not bounded. (see Para. 3.1.6)

Figures 21 through 23 showed the results for 30 Kb/in bit density. At 40 and 50 Kb/in the results would be even more pronounced, and even the Miller code would clearly show a wider spread between curves, than the M^2 - code, - again because its worst-case pattern, namely a long 101 sequence, would result in an unbounded digital sum variation. The resultant pattern sensitivity is revealed by use of the repeated digitized ramp function samples, but may remain hidden under pseudo-random number tests. We therefore conclude that future HBR systems should be designed for use with a zero-modulation code, of which the M^2 - code is a useful member and is distinguished by its ability to record and reproduce data in either the new M^2 - code, or in the Miller code, on one and the same recorder/reproducer system. Thus, existing Miller-recorded tapes can be reproduced equally as well as M^2 - recorded tapes.

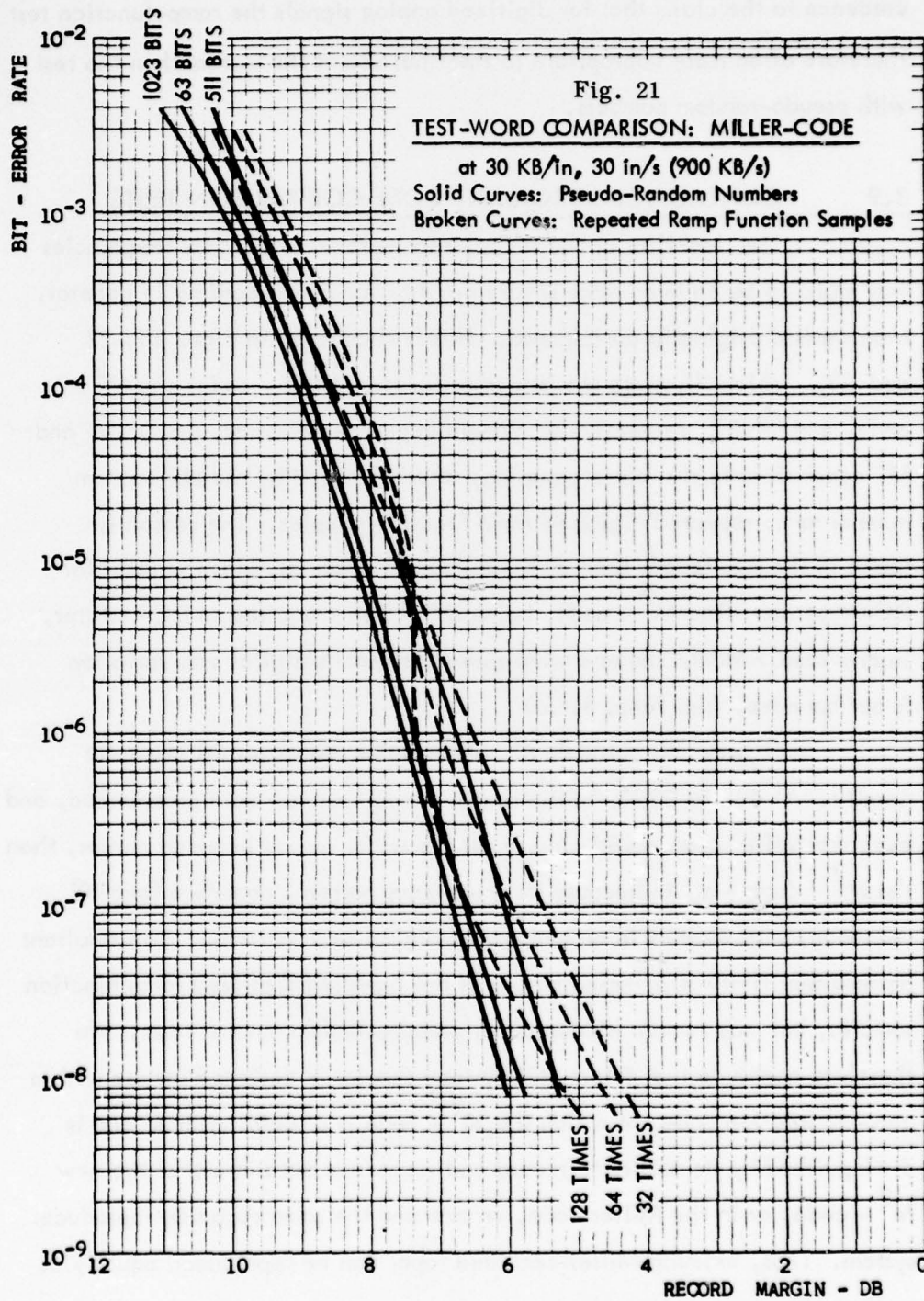

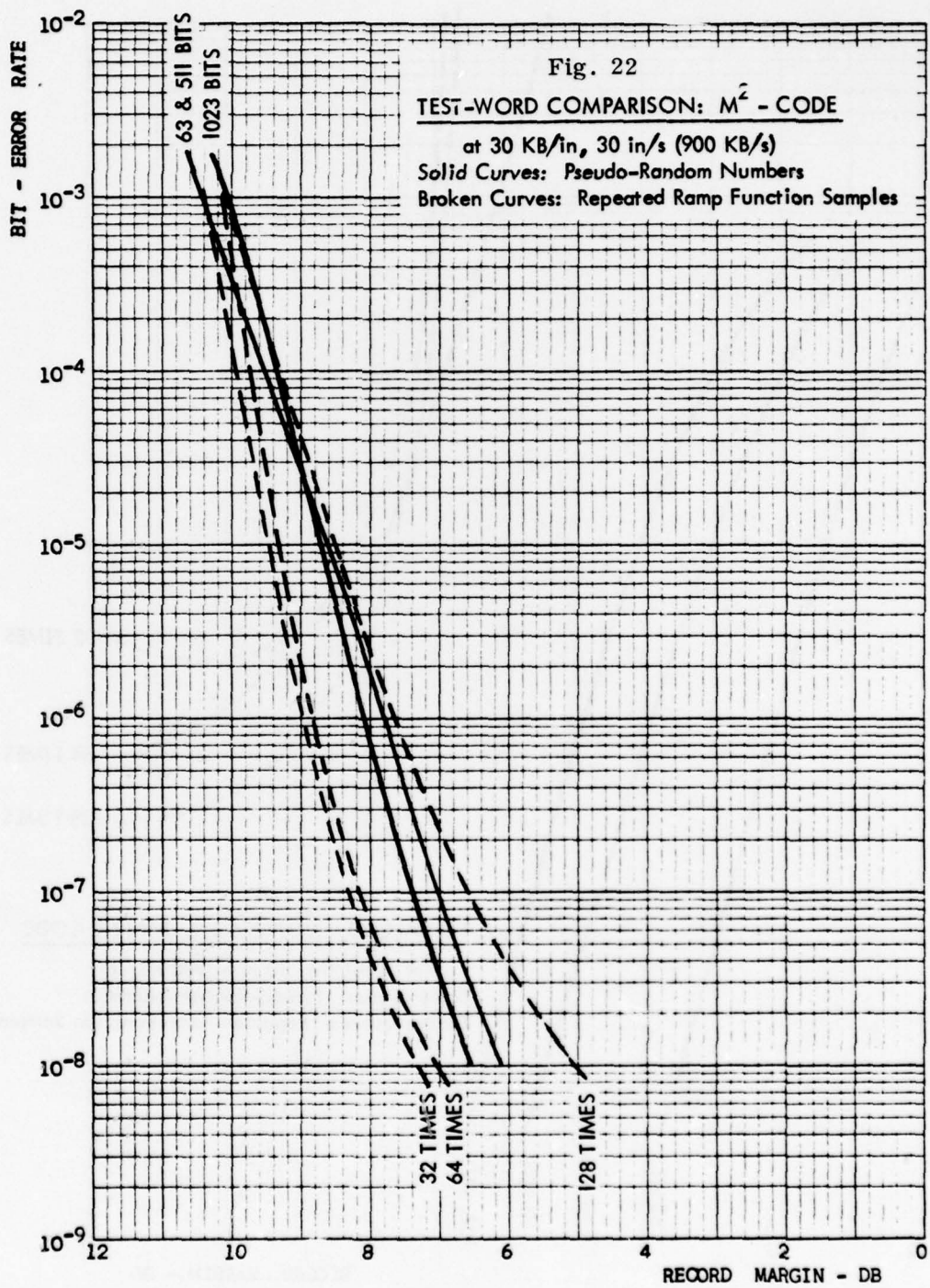

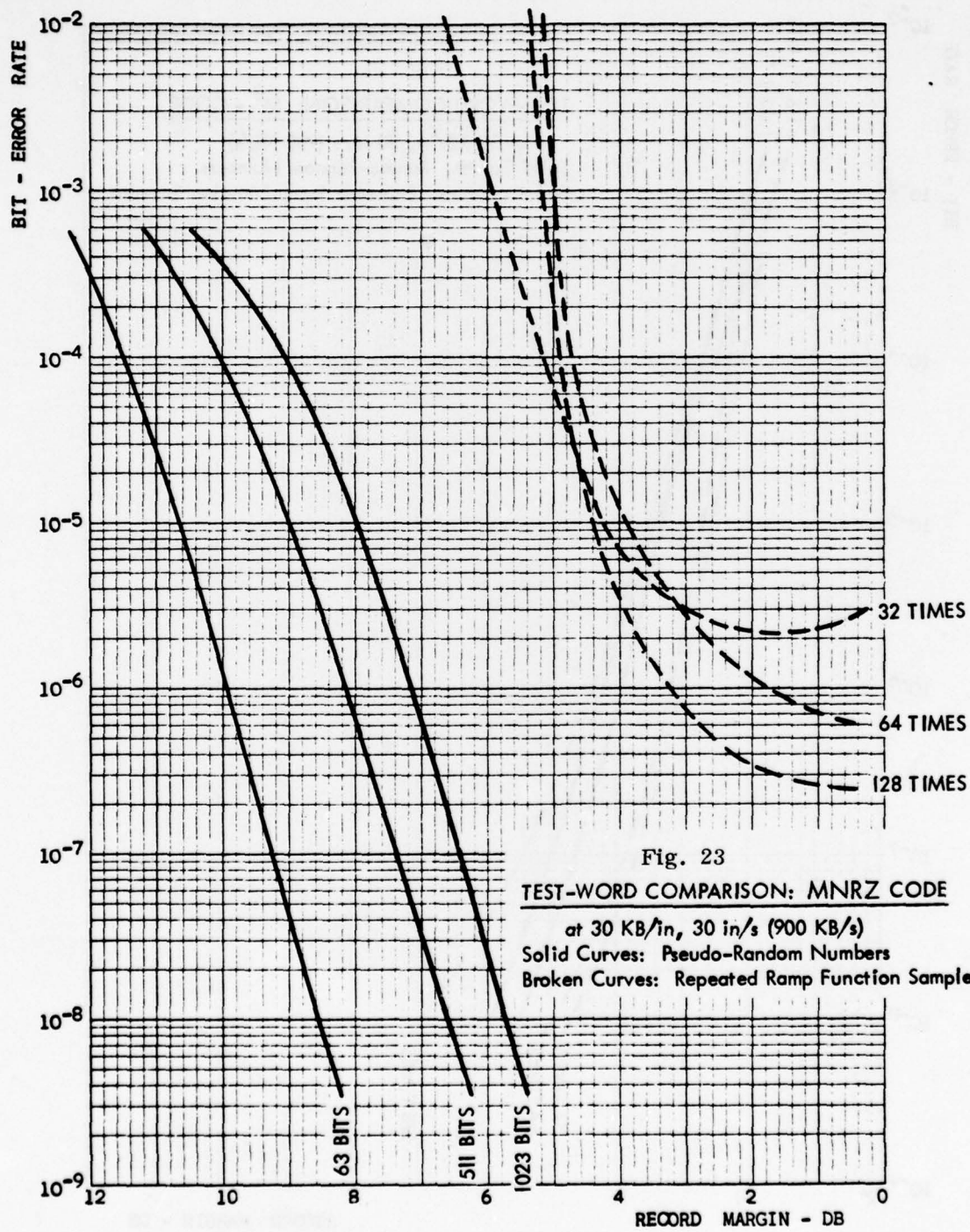

3.10 REFERENCES

- 3.1 Hecht, M., and A. Guida, "Delay Modulation," Proc. IEEE, July 1969, pp. 1314 - 1316.
- 3.2 Patel, A.M., "Zero-Modulation Encoding in Magnetic Recording", IBM J. Res. Develop., v. 19, No. 4, July 1975, pp. 366-378.
- 3.3. Ringkjøb, Erik T, "Achieving a Fast Data Transfer Rate by Optimizing Existing Technology," Electronics, May 1, 1975, pp. 86 - 91.
- 3.4 Lucky, R. W., J. Falz & E. J. Weldon, Jr., "Principles of Data Communication," McGraw-Hill 1968 pp. 186-189.

SECTION 4

INTERSYMBOL INTERFERENCE

4.1 PRE-EMPHASIS VS. POST-EQUALIZATION

4.1.1 Problem Description

Historically, analog instrumentation recorders have used post-equalization to compensate for the frequency distortion effect of the reproduce head. The RMS value of voltage induced by the flux rate-of-change increases with frequency, at 6 db/octave, and falls off at high-frequency band edge (i.e. at short wavelengths) due to the gap effect (Ref.4.1). In addition, pre-emphasis is used to correct for high-frequency losses in the core material of the record head. The purpose of the pre-emphasis has been to allow time-base expansion or contraction by reproducing at speeds other than that at which the recording was made and yet retain reasonably flat frequency response without the need for a different adjustment of the post equalizer at a given reproduce speed, depending upon the initial record speed. This type of pre-emphasis must, therefore, be included in any system capable of time base expansion or contraction.

The criterion for proper pre-emphasis in analog instrumentation recorders has always been frequency response, with no attention given to phase response. At bit-densities exceeding 25Kb/in it is expected that pre-emphasis will be required for the same reason as in analog recording. However, it is also expected that the pre-emphasis method will need to compensate for the phase distortions in the system which can contribute significantly to the intersymbol interference (Ref. 4.2).

No work was done under this contract to develop a pre-emphasis technique to solve this problem, although in the near future we shall initiate work toward a solution. The purpose of including this discussion in the report is to aid in the understanding of the overall data plots on code comparisons:

The tests at speeds other than 30 in/sec were done without the use of suitable pre-emphasis techniques and may therefore be subject to question.

4.1.2 Anti Pulse-Crowding

We did, however, study another type of pre-emphasis sometimes used in magnetic recording. It is aimed directly at the problem of intersymbol interference, independent of frequency, rather than at the compensation of record head losses only. A generally accepted term to describe this currently used type of pre-emphasis is not available, but it might be described as time-domain antipulse-crowding pre-emphasis. It varies in implementation, and has been used successfully in the signal system of computer disk drives. In these systems the signal is recorded in the Miller Code but is modified in such a manner as to reduce intersymbol interference. The modification consists of the storage of several bits of data, followed by a slight time displacement of certain zero crossings, so as to offset that motion which will take place on reproduction, due to intersymbol interference.

4.1.3 Peak Detection in Computer Transports

In conventional computer tape systems equalization to eliminate the 6 db/octave "roll-off" of the reproduce head output is never used. Some more modern systems used post equalization to extend the roll-off over a greater frequency range to increase packing density (Ref. 4.3). However, with the possible exception of the most recent ones, none compensate for the roll-off through the use of an integrating circuit, as has been the practice in instrumentation recorders since their inception.

In computer tape recorders it is customary to attempt reconstruction of the input signal from the output of the reproduce head, without an integration process to compensate for the differentiation process inherent in reproduce heads. This can be accomplished in a number of ways (Ref. 4.4). One of the most common

is the use of peak detection. Figure 24 illustrates why peak detection is used.

The signal output from the reproduce preamplifier, or from the reproduce head if no preamplifier is used, is sketched in Figure 24b.

As seen from Figure 24b, peak detection is based on differentiation of the recorded signal, a process which impairs the SNR by accentuating noise peaks. (Ref. 4.4, p. 115) In conventional digital recording, because of the low packing densities; the SNR is adequate. However, at the packing densities of interest on this program, noise becomes a more severe problem and peak detection cannot be used.

4.1.4 High Bit-Densities: Behr-Blessum Technique

If the position of the peaks of the pulses can be detected, the pulse sequence can be accurately re-constructed. This system operates very well at low packing densities. However, as the packing density is increased, the pulses tend to interfere with one another and a phenomenon known as "peak shift" occurs due to pulse crowding which, as stated earlier, is comparable to inter-symbol interference. The technique proposed by Behr-Blessum to reduce this effect is to predict which peaks will shift in which direction and to move the zero crossings in the opposite direction prior to recording. (Ref. 4.5).

Oscilloscope photographs indicated that the Behr Blessum technique did in fact reduce antipulse crowding when recordings were made at the densities of interest on this program, just as it reduced it at the lower densities studied by Behr-Blessum. However, the technique degraded the SNR of the system significantly. At the lower packing densities used in computer tape transports, the SNR is still very adequate. However, at the higher packing densities, the shorter wavelengths recorded require the use of shorter gap lengths in the reproduce head which results in a lower SNR even before implementation of the Behr-Blessum technique which, in turn, further degrades the SNR.

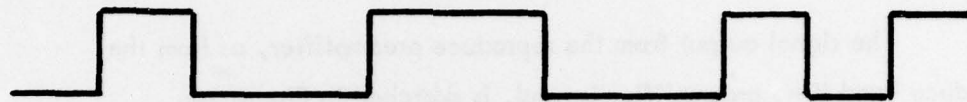

(a) Input Signal to the Record Head

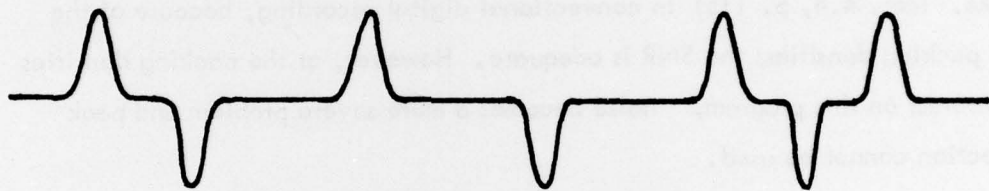

(b) Output Signal from the Reproduce Head

FIGURE 24 RECORD AND REPRODUCE WAVE FORMS FOR TYPICAL COMPUTER TAPE RECORDER

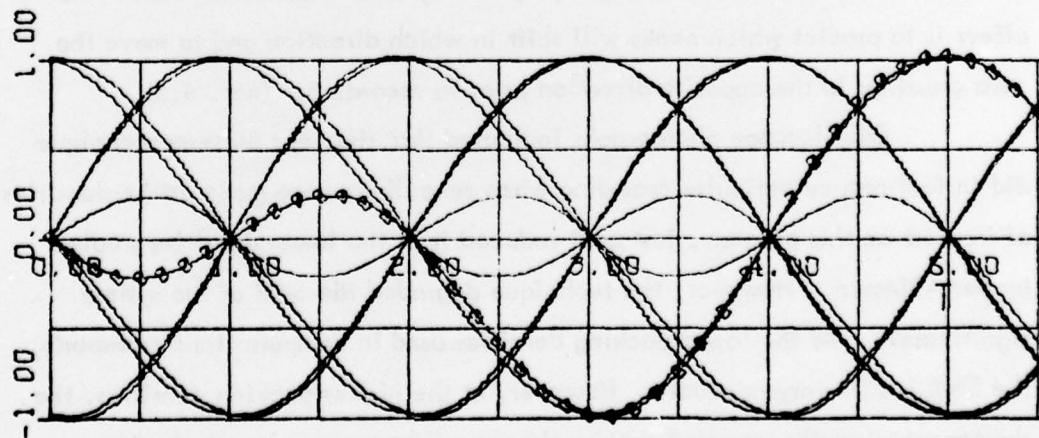

FIGURE 25 TYPICAL COMPUTER-CALCULATED EYE PATTERN

Furthermore, at the higher packing densities the equalization technique used is of the type which integrates the signal from the reproduce head. It was determined that although the peaks of the output pulses from the preamplifier were, in fact, positioned more correctly when using the Behr Blessum technique than when it was not used, the positions of the zero crossings after integration were misplaced by a larger amount. That is, the technique actually increased, rather than decreased, the intersymbol interference.

The Behr-Blessum method is based on the assumption that peak detection (or equivalent) would be used. Its unsuitability for high-density digital recording thus makes the Behr-Blessum technique unsuitable, too.

4.2 COMPUTER SIMULATION

Early in the program it was decided to use computer simulation techniques to aid in understanding the problems of intersymbol interference. The intent was to identify potential equalization techniques which would reduce intersymbol interference. To this end a program was written which would plot eye patterns for various channel characteristics and various data patterns. An example of such a plot is shown in Figure 25. In comparing eye patterns plotted by the computer to those observed in the hardware, it became apparent that the result lost meaning unless the DC restorer were also simulated on the computer, since the basic bit detection process takes place after DC restoration. This recognition coincided with the development of the M^2 -code, which does not require a DC restorer. The computer simulation effort was consequently discontinued.

4.3 REFERENCES

- 4.1 Stewart, W. E., "Magnetic Recording Techniques," McGraw-Hill, 1958.
- 4.2 Gibby, R. A. and J. W. Smith, "Some Extension of Nyquists Telegraphy Theory." BSTJ Sept. 1965, pp. 1487-1510.
- 4.3 Jacoby, G. V., "Signal Equalization in Digital Magnetic Recording", IEEE Trans. on Magnetics.
- 4.4 Bycer, B.B., "Digital Magnetic Tape Recording: Principals and Computer Applications." Hayden Book Co. 1965, p.p. 110-118.
- 4.5 Behr, M. and N. Blessum, "Technique for Reducing Effects of Pulse Crowding in Magnetic Recording," IEEE Trans. on Magnetics, Sept. 1972.

SECTION 5

RECOMMENDED FUTURE RESEARCH

5.1 CODE STUDIES

Although the results of the study thus far are rather persuasive, some of the shortcomings mentioned in Para 3.2.6 and 3.3.3 might be reviewed and, perhaps, some of the tests re-run.

The bandwidth of the test set-up was limited by the electronics available at the outset. Newer circuits would allow doubling the frequency range, i.e. extending the tests to 120 and 180 in/s.

Additional codes should be tested, as they become known. For the sake of completeness, the odd-parity type of MNRZ (i.e. ENRZ) should also be included.

The effectiveness of DC-restoration should be juxtaposed to the results of using peak-detection.

The relation between SNR and record margin should be investigated and quantitatively defined.

5.2 STANDARDIZATION

It might be desirable to develop a standard test tape, by means of which different recorders could be evaluated, aligned, and compared. Such tapes, similar to the so-called speed tapes used to standardize the performance of computer tape transports, would contain various data patterns, in various codes and for a range of bit densities. The recorder would be tested over several defined running speeds of the test tape.

Another form of standardization relates to the selection of one or more test patterns: For example, the pseudo-random number, a digitized ramp function, a digitized sine wave, and perhaps others.

5.3 HEAD DEVELOPMENT

Thought might be given to the selection of materials unique to digital heads - where linearity is no longer a requirement. Thus, one might examine nonlinear magnetic materials.

Another area of potential value concerns the development of thin-film heads. Such designs are, in fact, being actively pursued for computer disks, but could be made suitable for tape, also. Success in this area would greatly reduce head costs - by far the largest single item in the life cycle cost of high bit-rate recorders. It might also allow higher track densities than are currently considered safe.

5.4 EQUALIZER DEVELOPMENT

For machines reproducing at a lower tape speed than was used for the initial recording, pre-equalization is needed, in addition to suitable post-equalization. Quite possibly, such equalization could be made self-adjusting.

5.5 ERROR DETECTION AND CORRECTION (EDAC)

As bit densities exceed some upper limit, e.g. 50 Kb/in at present for the M^2 code, and BER's are required to remain at 10^{-6} or lower, error correction codes must be used. To this end, it will be necessary to accumulate statistics for error occurrence in multitrack digital recorders.

Suitable selection of a sync word may greatly aid in the design of an efficient EDAC code. Data may be reformatted, to further aid in this process. Finally, the Group Coding methods successfully employed in computer tape equipment can be applied.

SECTION 6

APPENDIX

6.1 SOURCES OF BIT-ERRORS

Before efficient Error Detection and Correction (ED AC) methods can be developed, the statistical distribution of errors must be determined. The complexity of a generalized approach becomes obvious when the factors influencing error distribution are listed. For example, the most basic parameter affecting BER is the recorder's analog signal-to-noise ratio (SNR). It, in turn, is defined by the following system parameters: Average tape-output level; tape speed; head design; crosstalk; noise susceptibility; design of head driver, preamplifier, and reproduce amplifier; design and adjustment of equalizer; and filter design. We will assume that the SNR has initially been optimized, although there remains significant doubt about the relation between phase equalization and BER, for any one specific recording code. Moreover, the SNR may vary substantially from track to track even in any one given recorder. In the following paragraphs we list other factors influencing the statistical error distribution.

6.1.1 Tape Dropouts

A decrease in playback signal can result from point-to-point variations of tape quality or of head-to-tape contact. The resultant loss of SNR may lead to errors in the bit detection process. These errors can be isolated, but in more severe cases will occur in bursts of considerable lengths.

6.1.2 Zero-line Drift

If the recording code allows for fewer than one flux reversal per bit, (as is indeed the case with all currently used high bit-rate recording codes), the zero line will experience positive or negative displacements determined by the

elapsed time between reversals. If a noise pulse occurs at the time of displacement, it may cause an error in the detection process. This effect exists even though a DC-restorer may be used to ameliorate the zero-line drift. (The M^2 - code minimizes zero-line drift).

6.1.3 DC-Restorer Effects

A DC-restorer is generally used to prevent excessive zero-line drift. Unfortunately, the DC-restorer can also cause conversion of isolated errors into bursts of errors. (The M^2 - code does not require a DC-restorer).

6.1.4 Loss of Sync Word

Recording codes may require the inclusion of a "sync word", whose length may be a single bit (e.g. the eighth bit in the Modified NRZ code) or longer (e.g. the 101 sequence required in the Miller code). Loss of the sync word, from whatever cause, will result in an error burst until the next sync word is correctly acquired.

6.1.5 Simultaneous Bursts

The data on each input line can be distributed over several recorder tracks and recombined into a corresponding output line after playback. In this mode, an error burst in any one recorder track is converted to a series of isolated errors separated by as many bits as there are tracks per input line. However, simultaneous error burst occurrences in two or more tracks (e.g. due to dropouts) will tend to complicate this desirable feature.

6.1.6 Loss of Frame Sync

It is often necessary to align the data on the several tracks of a recorder, after playback and prior to output, so as to assure synchronized reproduction from all tracks, and prior to recombination into a serial bit stream if desired. Such "deskewing" is performed by insertion of a suitable "frame sync" signal, which is

used to arrange the data into convenient "frames", as a reference for synchronized release from buffer registers. Failure to detect and identify such a frame sync signal will result in an error burst of considerable length; i.e., an entire frame may now be in error.

6.2 COMMENTS ON TAPE SELECTION

The importance of tape selection cannot be overemphasized, in conducting code comparison tests: Tape "dropouts", however the term may be defined, tend to becloud the cause of the measured BER. Only tape of the highest quality and specially made for high density digital recording is therefore suitable for such experiments.

6.2.1 Series 797 Tape

The Ampex Magnetic Tape Division has most recently introduced a superior instrumentation tape closely designed to industry needs. The 797 performance specifications are as follows:

Sensitivity (200 KHz at 120 ips):	0 \pm 1 dB
Response at:	
1 mil:	0 \pm 1 dB
0.25 mil:	0 \pm 1 dB
0.125 mil:	0 \pm 1 dB
0.10 mil:	0 \pm 1 dB
0.08 mil:	0 \pm 1.5 dB
0.06 mil:	0 \pm 2.0 dB
Uniformity (Long and Short Term)	2.0 dB max.

Dropouts: No more than 10 per any 100-foot section on center tracks and no more than 15 per any 100-foot section on edge tracks (not averaged).

If these specifications are compared with 786/787 tape, sizable performance improvements will be noticed. This is especially true in regard to tape-to-tape and batch-to-batch uniformity. 797 tape will perform better than 786 or 787 but it still lacks the appropriate dropout-free performance. Even though 797 tape will provide 3 to 4 dB SNR improvement on most systems, which certainly improves high-density digital performance, the dropout rate can be as high as 10 per 100 feet.

6.2.2 Series 799 Tape

Taking 797 tape one large step further through special processing and 100% testing, a satisfactory tape can be provided. Field applications have shown reliable performance at bit packing densities of 30 Kb/in, with BER of 1×10^{-7} , and better. Each reel is tested with the use of 25-mil heads (28 track format) over 14 equally spaced tracks. On the average, only one dropout per track is allowed, per 100 feet of track. No more than 10 dropouts per track are allowed in any 100-foot section of tape and no more than 125 dropouts over 28 tracks per any 100-foot section. A dropout is defined as a 75% (12 dB) loss of signal for a period of one microsecond.

Although the depth of a dropout has been increased, its length has been shortened to 1/10 of the GSA-specified dropout length. In addition, restrictions have been placed on the maximum number of dropouts allowable across the tape or in a concentrated area, to force the dropouts to be randomly distributed.

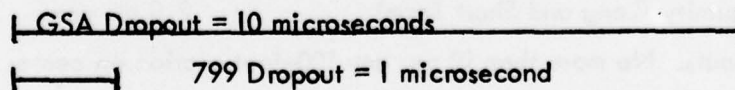

6.2.3 Conclusion

Although GSA-qualified tapes may provide satisfactory performance for high-density digital systems, there is no guarantee that they will. The W-T-001553 specification in itself is not designed for high-density digital

recording although it is an excellent specification for general analog recording applications. To receive confidence in tape performance for high density digital applications requiring a low BER, special processing and 100% testing of the tape by the tape manufacturer is needed. For reference, the specification sheet for Series 799 tape is shown on the following page.

REFERENCES

- 2.1 A. Miller, U.S. Patent 3,108,261 October 22, 1963.
- 2.2 Wells, Jon B., "High Density PCM Magnetic Tape Recording," International Telemetry Conference, 1973, pp. 66-73.
- 3.1 Hecht, M., and A. Guida, "Delay Modulation," Proc. IEEE, July 1969, pp. 1314 - 1316.
- 3.2 Patel, A.M., "Zero-Modulation Encoding in Magnetic Recording," IBM J. Res. Develop., v. 19, No. 4, July 1975, pp. 366-378.
- 3.3 Ringjob, Erik T., "Achieving a Fast Data Transfer Rate by Optimizing Existing Technology," Electronics, May 1, 1975, pp. 86 - 91.
- 3.4 Lucky, R. W., J. Falz and E. J. Weldon, Jr., "Principles of Data Communication," McGraw-Hill 1968 pp. 186-189.
- 4.1 Stewart, W.E., "Magnetic Recording Techniques," McGraw-Hill, 1958.
- 4.2 Gibby, R.A. and J. W. Smith, "Some Extension of Nyquists Telegraphy Theory." BSTJ Sept. 1965, pp. 1487-1510.
- 4.3 Jacoby, G.V., "Signal Equalization in Digital Magnetic Recording," IEEE Trans. on Magnetics.
- 4.4 Bycer, B.B., "Digital Magnetic Tape Recording: Principles and Computer Applications." Hayden Book Co. 1965, pp. 110-118.
- 4.5 Behr, M. and N. Blessum, "Technique for Reducing Effects of Pulse Crowding in Magnetic Recording," IEEE Trans. on Magnetics, Sept. 1972.