

AD-A037 435

NATIONAL AVIATION FACILITIES EXPERIMENTAL CENTER ATL--ETC F/G 1/2  
FLIGHT TEST AND EVALUATION OF MDEC (MCDONNELL DOUGLAS ELECTRONI--ETC(U)  
FEB 77 T J TURNOCK, H SCOZZAFAVA

UNCLASSIFIED

FAA-NA-76-23

FAA-RD-75-231

NL

1 of 3  
ADA037435

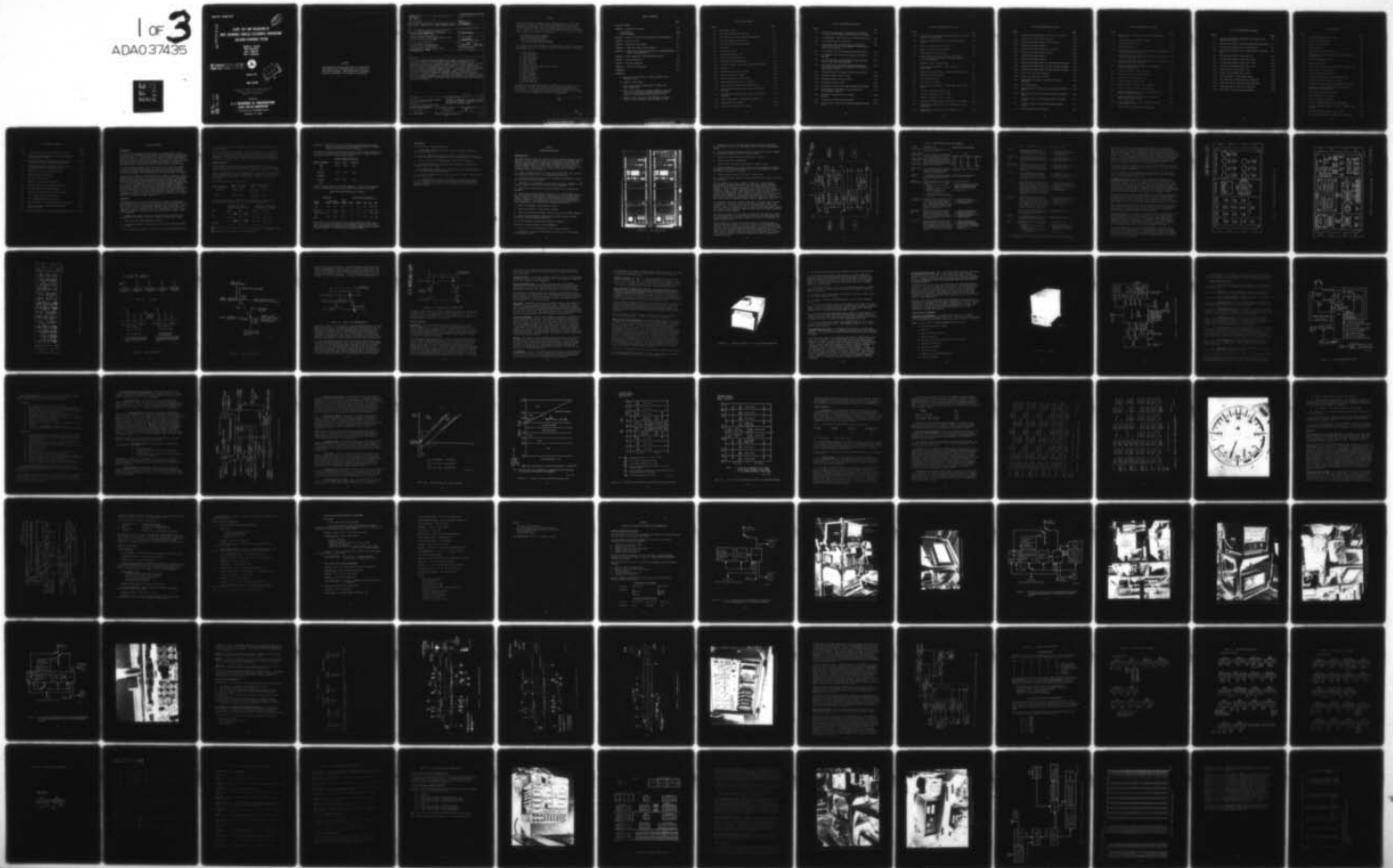

1 OF

3

ADA037435

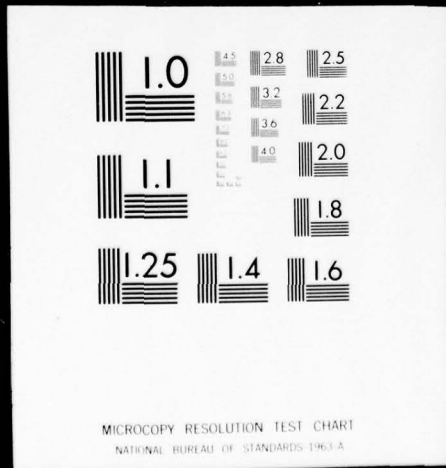

Report No. FAA-RD-75-231

12  
B.S.

ADA 037435

**FLIGHT TEST AND EVALUATION OF  
MDEC (McDONNELL DOUGLAS ELECTRONICS CORPORATION)  
COLLISION AVOIDANCE SYSTEM**

Theodore J. Turnock  
Henry Scozzafava  
John J. Wojciech  
Kent T. Culbertson

**COPY AVAILABLE TO DDC DOES NOT  
PERMIT FULLY LEGIBLE PRODUCTION**



February 1977

**FINAL REPORT**

DDC  
RECEIVED  
MAR 28 1977  
C

Document is available to the public through the  
National Technical Information Service  
Springfield, Virginia 22151

Prepared for

**U. S. DEPARTMENT OF TRANSPORTATION  
FEDERAL AVIATION ADMINISTRATION**

Systems Research & Development Service

Washington, D.C. 20590

AD No. \_\_\_\_\_  
DDC FILE COPY

NOTICE

This document is disseminated under the sponsorship of the Department of Transportation in the interest of information exchange. The United States Government assumes no liability for its contents or use thereof.

Technical Report Documentation Page

1. Report No. FAA-RD-75-231	2. Government Accession No.	3. Recipient's Catalog No.	
4. Title and Subtitle FLIGHT TEST AND EVALUATION OF MDEC (MCDONNELL DOUGLAS ELECTRONICS CORPORATION) COLLISION AVOIDANCE SYSTEM.		5. Report Date February 1977	6. Performing Organization Code
7. Author(s) Theodore J. Turnock, Henry Scozzafava, John J. Wojciech, and Kent T. Culbertson	8. Performing Organization Report No. FAA-NA-76-23		10. Work Unit No. (TRAIS)
9. Performing Organization Name and Address Federal Aviation Administration National Aviation Facilities Experimental Center Atlantic City, New Jersey 08405		11. Contract or Grant No. 052-241-000	13. Type of Report and Period Covered Final rept. January 1975 - October 1975
12. Sponsoring Agency Name and Address U.S. Department of Transportation Federal Aviation Administration Systems Research and Development Service Washington, D.C. 20590		14. Sponsoring Agency Code 12/287p	
15. Supplementary Notes			
16. Abstract This report covers the test and evaluation of commercial and general aviation versions of airborne collision avoidance system (ACAS) equipments which are candidates for selection in a National Standard Collision Avoidance System. The CAU (collision avoidance unit) and Mini-CAS were evaluated for their communications range, reliability, synchronization, and their ability to provide timely and correct advisories (Tau 2) and maneuver commands (Tau 1). In addition, range and range rate accuracy and display reliability were analyzed. Based on these studies, it is concluded that the CAU and Mini-CAS equipments perform the collision avoidance function as described in ANTC 117. The report also summarizes the operation of the ground and airborne equipment, along with brief descriptions of the aircraft installation, test instrumentation, flight test outline, and the various problems encountered during the evaluation.			
17. Key Words Airborne Collision Avoidance System Collision Avoidance Unit Mini-CAS Collision Avoidance Ground Station Communications Reliability		18. Distribution Statement Document is available to the public through the National Technical Information Service, Springfield, Virginia 22151	
19. Security Classif. (of this report) Unclassified	20. Security Classif. (of this page) Unclassified	21. No. of Pages 27	22. Price

240 550

(A)

bpg

PREFACE

The airborne collision avoidance system (ACAS) program, one of the largest flight test programs ever conducted at the National Aviation Facilities Experimental Center (NAFEC) was accomplished through the efforts of many different NAFEC entities. While it is impractical to list all, acknowledgement is given herein to the following who supported the Systems and Equipment Engineering Branch, ANA-140, in the project:

Data Preparation Section, ANA-245,  
Instrumentation Branch, ANA-320,  
Graphic Arts Branch, ANA-520,  
Data Processing Branch, ANA-550, and  
Aviation Facilities Division, ANA-600.

The contributions of the individuals in these branches at NAFEC are gratefully acknowledged. Due special recognition, however, are the members of the ACAS team listed below:

J. Beaty, ANA-140,  
F. Baraccini, ANA-140,  
J. Carr, ANA-140,  
J. Cibinski, ANA-140,  
W. Gadow, ANA-140,  
J. Fisher, ANA-140,  
D. Henry, ANA-140,  
P. Karsten, ANA-110,  
V. Lasewicz, ANA-140 - NAFEC Program Manager,  
R. Lamprecht, ANA-140,  
V. Luciani, ANA-140  
A. Madge, ANA-243,  
C. Munafo, ANA-550,  
R. Polillo, ANA-550,  
D. Riley, ANA-550,  
R. Sadowiczak, ANA-550,  
D. Timateo, ANA-550,  
F. Wesighan, ANA-140.

In addition, J. Brennan and Owen McIntire, ARD-210, who provided the program management between NAFEC and McDonnell Douglas Electronics Company, are acknowledged. Also the technical engineering support provided by McDonnell Douglas Electronics Company, with special recognition to Messrs. K. E. Toerper, W. Von Fange, J. Willingham, and D. Earnest is acknowledged.

## TABLE OF CONTENTS

	Page
EXECUTIVE SUMMARY	1
CHAPTER 1 - Equipment Description	1-1
Ground Station	1-1
Airborne Equipment	1-15
CHAPTER 2 - Aircraft Installation and Flight Test Instrumentation	2-1
CHAPTER 3 - Laboratory Test	3-1
CHAPTER 4 - Flight Test Plan Summary	4-1
CHAPTER 5 - Flight Test Results and Conclusions	5-1
CHAPTER 6 - Communications Range and Reliability and Synchronization Accuracy and Reliability	6-1
CHAPTER 7 - Range, Range Rate, and Warning-Time Accuracy	7-1
CHAPTER 8 - Display Reliability	8-1
CHAPTER 9 - Altitude Boundaries	9-1
CHAPTER 10 - Notes and Observations	10-1
REFERENCES	11-1
APPENDICES	
A - ANA-140, ACAS T/F Results of Flight Acceptance Test, January 22, 1975	
B - Summary of ACAS Flights	
C - Notes from Log Book on NAFEC Support by MDEC from May to August 1975	
D - MDEC Letter, Completion of Factory Acceptance Test with a List of Failure Reports Requiring Review and Waiver Approval by Contracting Official, October 9, 1974	
E - ARD-242 Letter, Decision to Test MDEC CAS in Identical Fashion as RCA and Honeywell CAS, November 13, 1974	

## LIST OF ILLUSTRATIONS

Figure		Page
1-1	CAS Ground Station	1-2
1-2	CAS Ground Station Block Diagram	1-4
1-3	CAS Ground Station Power Control/Monitor Panel	1-8
1-4	CAS Ground Station Display Panel	1-9
1-5	CAS Ground Station Test Point Panel	1-10
1-6	CAS Epochs	1-11
1-7	Epoch Start Triads	1-11
1-8	Coarse Synchronization ●	1-12
1-9	Initial Fine Synchronization	1-13
1-10	Continuous Fine Synchronization	1-14
1-11	Collision Avoidance Unit (CAU) and Maneuver Indicator	1-17
1-12	Mini-CAS	1-20
1-13	CAS/FBS Functional Block Diagram	1-21
1-14	CAU Functional Block Diagram	1-23
1-15	CAU Logic Functional Block Diagram	1-26
1-16	Range and Range Rate Threat Evaluation	1-28
1-17	Threat Evaluation Altitude and Altitude Rate	1-29
1-18	Low-Altitude Threat/Evaluation Output, Two-Aircraft Encounter	1-30
1-19	High-Altitude Threat/Evaluation Output, Two-Aircraft Encounter	1-31
1-20	Threat Logic Output, Three-Aircraft Encounter	1-34
1-21	Maneuver Indicator Display	1-36
1-22	dR/dT Unit Functional Block Diagram	1-38

LIST OF ILLUSTRATIONS (Continued)

Figure		Page
2-1	N42 CAU Installation with Instrumentation Consisting of Digital Recorder/Magnetic Tape Interface and Display	2-2
2-2	N42 CAU/Magnetic Tape Interface and Display Installation	2-3
2-3	N42 Digital Recorder Installation	2-4
2-4	N377 CAU/Mini-CAS Installation with Instrumentation Consisting of Digital Recorder/Magnetic Tape Interface and Photopanel Display	2-5
2-5	N377 CAU/Mini-CAS with Synchronized Time Installation	2-6
2-6	N377 Magnetic Tape Interface and Display with Digital Recorder	2-7
2-7	N377 CAS Photopanel Instrumentation Display and TACAN Air-Air Range Measurement Equipment	2-8
2-8	N376 CAU/Mini-CAS Installation with Instrumentation Consisting of Digital Recorder/Magnetic Tape Interface and Photopanel Display	2-9
2-9	G159 Gulfstream Pilot Maneuver Indicator Installation	2-10
2-10	CAS/TACAN Antenna Location on N377	2-13
2-11	CAS/TACAN Antenna Location on N376	2-14
2-12	CAS Antenna Location on N42	2-15
2-13	CAS Magnetic Tape Interface and Instrumentation Display	2-16
2-14	Block Diagram of CAS Magnetic Tape Interface and Instrumentation Display	2-18
2-15	Photopanel Instrumentation and Display Monitor	2-28
2-16	Photopanel Instrumentation and Display	2-29
2-17	Gulfstream N377 TACAN Air-Air Range Measurement Installation	2-31

LIST OF ILLUSTRATIONS (Continued)

Figure		Page
2-18	TACAN Air-Air Range Equipment Showing TACAN with Formatter and Time Code/WWV Receiver	2-32
2-19	Functional Diagram of TACAN Air/Air Range Measurement System	2-33
2-20	Sample of TACAN "Quick Look" Printout	2-34
2-21	Sample of CAS "Quick Look" Printout	2-37
3-1	Receiver Sensitivity Test Setup	3-2
3-2	Detected Video and Threshold Video, Scope Adjusted to 5.0 $\mu$ s/Division with Output Attenuator Adjusted for Clean Waveshapes	3-3
3-3	Laboratory Setup for Output Power	3-6
4-1	Communications Reliability. Single Daisy over a Figure Eight	4-5
4-2	Communications Reliability. Double-Daisy Flight Pattern	4-6
4-3	NAFEC Instrumentation Range	4-10
4-4	Two-Aircraft Encounter	4-11
4-5	Three-Aircraft Encounter	4-12
6-1	Communications Reliability. Single Daisy over a Figure Eight	6-2
6-2	Geometric Limitations, N377 vs. N42	6-6
6-3	Geometric Limitations, N377 vs. N376	6-7
6-4	Geometric Limitations, N377 vs. N376	6-8
6-5	Communications Range Flights, N377 (CAU) vs. N42 (CAU)	6-10
6-6	Communications Range Flights, N377 (Mini-CAS) vs. N376 (Mini-CAS)	6-11
6-7	Communications Range Flights, N377 (Mini-CAS 2) vs. N376 (CAU 2)	6-13

LIST OF ILLUSTRATIONS (Continued)

Figure		Page
6-8	Communications Range Flights, 10, 11, 12, 13, and 14	6-15
6-9	Communications Range Flights 10 and 11	6-16
6-10	Communications Range Flights, 20, 23, and 26	6-17
6-11	Communications Range Flight 20	6-18
6-12	Communications Range Flights 19, 43, and 48	6-19
6-13	Communications Range Flights 8 and 41	6-21
6-14	Communications Range Flight 31	6-23
6-15	Communications Range Flight 54	6-24
6-16	Communications Range Flight 38, Three-Aircraft Encounter	6-26
6-17	Communications Range Flight 38, Three-Aircraft Encounter	6-27
6-18	Communications Range Flight 38, Three-Aircraft Encounter	6-28
6-19	Typical CAS Input Data, Aircraft 1	6-30
6-20	Typical CAS Input Data, Aircraft 2	6-32
6-21	Communications Reliability Run Output Data, N377 (Mini-CAS)	6-36
6-22	ACAS Message Format	6-41
6-23	Sample Listing of Synchronization Difference Statistics (Run 1)	6-43
6-24	Sample Listing of Synchronization Difference Statistics (Run 2)	6-44
7-1	A Sample Listing of CAS Photopanel Reduction Program Printout	7-3
7-2	A Sample Listing of the CAS/Tracker Merge Program Printout	7-5
7-3	Mean Range Rate Error Estimation	7-14

LIST OF ILLUSTRATIONS (Continued)

Figure		Page
7-4	Tau 1 and Tau 2 Thresholds as Function of True Radial Range Rate	7-15
7-5	Range and Range Rate Threat Evaluation	7-17
7-6	Mini-CAS Warning-Time Plot	7-23
7-7	CAU Warning-Time Plot	7-24
7-8	Histograms and Fitted Normal Distributions for Warning-Time Percent Deviation Data (Tau 1)	7-26
7-9	Histograms and Fitted Normal Distributions for Warning-Time Percent Deviation Data (Tau 2)	7-27
7-10	Histograms and Fitted Normal Distributions for Warning-Time Deviation Data (Tau 2 and Tau 1)	7-28
8-1	Example Warning-Light Performance Plot and Related Display Reliability Data	8-2
8-2	Flight 41, 90°/300°, -150° Encounter	8-4
8-3	Flight 41, 255°/105°, -150° Encounter	8-5
8-4	Flight 49, Run 7, 90° Encounter	8-6
8-5	Flight 49, Run 8, 90° Encounter	8-7
8-6	Flight 15, Run 1, 270°/90°, 180° Encounter	8-8
8-7	Flight 15, Run 2, 75°/255°, 180° Encounter	8-9
8-8	Display Reliability for CAU vs. CAU Configuration by Angles between Radials Flown	8-14
8-9	Display Reliability for Mini-CAS vs. Mini-CAS by Angles between Radials Flown	8-15
8-10	Display Reliability for CAU vs. Mini-CAS by Angles between Radials Flown	8-16
9-1	Threat Evaluation Altitude and Altitude Rate	9-2

LIST OF ILLUSTRATIONS (Continued)

Figure		Page
9-2	Pressure Altitude Code Transmission and Example of the Digital Input to CAS	9-3
9-3	Altitude Zone Boundary Coaltitude (Mini-CAS vs. Mini-CAS)	9-5
9-4	Altitude Zone Boundary Level, 3,300/3,400 Feet	9-6
9-5	Altitude Zone Boundary Level, 1,800/1,900 and 1,300/1,400 Feet	9-7
9-6	Altitude Zone Boundary, Coaltitude Zone	9-8
9-7	Altitude Zone Boundary, Epoch 1295 to 1344	9-9
9-8	Altitude Zone Boundary, Epoch 1345 to 1394	9-10
9-9	Altitude Zone Boundary, Epoch 1395 to 1444	9-11
9-10	Lateral Turn-In, Epoch 1689 to 1783	9-12
9-11	Lateral Turn-In, Epoch 2279 to 2361	9-13
9-12	Lateral Crossover, Lower Flight Turning	9-15
9-13	Dive (Mini-CAS vs. Mini-CAS) below 10,000 Feet	9-16
9-14	Climb (Mini-CAS vs. Mini-CAS) below 10,000 Feet	9-17
9-15	Climb (Mini-CAS vs. CAU) below 10,000 Feet	9-18
9-16	Dive (CAU vs. CAU) above/below 10,000 Feet	9-19

LIST OF TABLES

Table		Page
1-1	Ground Station Built-In Test (BIT)	1-5
2-1	Aircraft Antenna Location	2-12
2-2	Magnetic Tape Data Format	2-19
2-3	Field Content List	2-24
2-4	Definitions for Field Content List	2-25
2-5	Test Mode Information Ground Station Test Transmissions for Odd Epochs	2-36
3-1	Receiver Sensitivity (in dB)	3-5
3-2	Power Output (Watts)	3-7
4-1	Communications Reliability--Double-Daisy Encounter Chart	4-4
4-2	Accuracy Flights (Two-Aircraft)	4-13
4-3	Accuracy Flights (Three-Aircraft)	4-14
4-4	Altitude Zone Boundaries (Pattern--Figure Eight)	4-16
5-1	RF Communications Reliability and Range	5-3
5-2	Communications Synchronization Reliability and Accuracy	5-4
5-3	Communication Synchronization Reliability Percent Receptions for Ground and Air	5-5
5-4	Range and Range Rate Error Estimates	5-6
5-5	Warning-Time Accuracy Estimates	5-7
5-6	Display Reliability Estimates	5-9
6-1	Ratios of Starting Distance from TACAN Station	6-4
6-2	RF Communications Reliability, Percent of Communications, Air-Air	6-39
6-3	COM Synchronization Accuracy (CAU vs. CAU)	6-45
6-4	COM Synchronization Accuracy (Mini-CAS vs. Mini-CAS)	6-45

LIST OF TABLES (Continued)

Table		Page
6-5	COM Synchronization Accuracy (Mini-CAS vs. CAU)	6-46
6-6	COM Synchronization Reliability, Percent, Receptions, Ground-Air (CAU vs. CAU)	6-47
6-7	COM Synchronization Accuracy Reliability, Percent, Receptions, Ground-Air (Mini-CAS vs. Mini-CAS)	6-48
6-8	COM Synchronization Accuracy Reliability, Percent, Receptions, Ground-Air (Mini-CAS vs. CAU)	6-49
7-1	Summary of the Accuracy Tests Performed	7-2
7-2	Mini-CAS Range Error Estimates	7-7
7-3	CAU Range Error Estimates	7-8
7-4	Summary of CAS Range Error Estimates	7-9
7-5	Mini-CAS Range Rate Error Estimates (Knots)	7-11
7-6	CAU Range Rate Error Estimates (Knots)	7-12
7-7	Data Base of Potentially Usable Warning Times	7-19
7-8	Tau 1 Warning-Time Data and Statistics	7-21
7-9	Tau 2 Warning-Time Data and Statistics	7-22
8-1	Display Reliability Data (CAU-CAU), Flights 8 and 41	8-10
8-2	Display Reliability Data (Mini-CAS-Mini-CAS), Flights 49 and 50	8-11
8-3	Display Reliability Data (CAU-Mini-CAS) Flights 15 and 16	8-12

## EXECUTIVE SUMMARY

### INTRODUCTION.

The Federal Aviation Administration (FAA) has been engaged during the past several years in evaluating various airborne collision avoidance systems (ACAS). One system concept is a time/frequency (T/F) family of equipments designed by McDonnell Douglas Co. The two air-derived collision avoidance system (CAS) or ACAS systems reported herein are the advanced Model 2000 CAU (collision avoidance unit) and a general aviation unit, designated a Mini-CAS. In addition, a development model T/F CAS ground station was used throughout the evaluation.

The Federal Aviation Administration (FAA) was directed by the U.S. Congress to report CAS progress and to arrive at a decision for a national CAS plan. In support, the flight test program conducted at the FAA National Aviation Facilities Experimental Center (NAFEC) was on the T/F ACAS family of equipments.

By midyear 1973, McDonnell Douglas Electronic Co. (MDEC) was under FAA contract DOT-FA 73WA-3239 (reference 1) to design, fabricate, and deliver a development model T/F CAS ground station and associated airborne equipment complying with Engineering Requirement FAA-ER-240-016, based on ANTC 117 standards (reference 2). A factory acceptance test of the T/F CAS system was made in September 1974. The field test which demonstrated that all subsystems, ground and airborne, were operable, optimized, and complied with the specifications was made in October 1974 at NAFEC. Acceptance flight testing was conducted during November 1974 and demonstrated that the T/F concept was ready for a complete flight evaluation. Acceptance test results are reported in appendix A. Final flight evaluation was started in January 1975 and completed in October 1975, whereby a total of 65 flights were made (appendix B).

### OBJECTIVES.

The overall objective of this test program was to evaluate the MDEC family of CAS equipments to perform the collision avoidance function as described in ANTC 117 (reference 2). An important program goal was to assure that a comparison of results could be made with other candidate systems competing in the evaluation. This was accomplished with test data gathered in laboratory and flight testing which included received sensitivity and output power. Flight tests determined:

1. Communications range, reliability, and synchronization accuracy of the radiofrequency (RF) link as a function of range and antenna aspect angles,
2. Range, range rate, and warning-time accuracy,
3. The display reliability, (the ability to give correct threat information to the pilot),
4. The conformance with ANTC 117 TAU zone and altitude zone boundaries, and

5. The ability of the ground station to transfer time synchronization to the airborne equipment.

The added functions and capabilities which included the (a) fly-by sync (FBS) (for air-to-ground synchronization of the ground station) and (b) extended range sync (for doubling the startup and resync range from the ground-to-air link) were not tested during the flight evaluation, but were briefly demonstrated during the acceptance test. The test results can be found in appendix A.

SUMMARY OF RESULTS.

The CAU and Mini-CAS provided sufficient avoidance warning to assure safe vertical separation as per the requirements of ANTC 117. Necessary avoidance warning was given even if one aircraft did not respond to the maneuver command.

Results indicated that the required communications range was more than adequate for all encounter angles flown. Communications reliability was over 90 percent from range point of establishment to the closest approach for all encounter angles flown.

The range and range rate accuracies were:

<u>Type of Equipment</u>	<u>Range Error (nmi)</u>		<u>Range Rate Error (Knots)</u>	
	<u>Mean</u>	<u>Std. Dev.</u>	<u>Mean</u>	<u>Std. Dev.</u>
Mini-CAS	-0.004	0.036	See Graph Fig. 7-3	13.5
CAU	0.019	0.032	See Graph Fig. 7-3	14.9

The warning time mean and standard deviations expressed as deviations from threshold and percentages of the Tau 2 and Tau 1 thresholds were:

	<u>Deviation from ANTC 117 Threshold* Tau (Seconds)</u>		<u>Deviation from ANTC 117 Threshold* Tau (Percent)</u>	
	<u>Tau 1</u>	<u>Tau 2</u>	<u>Tau 1</u>	<u>Tau 2</u>
<u>CAS</u>	$\bar{X} = -4.4 \triangle 1$	$\bar{X} = -1.6 \triangle 2$	$\bar{X} = -15.0$	$\bar{X} = -1.7$
<u>CAU</u>	SD = 2.0	SD = 2.8	SD = 7.0	SD = 3.0
<u>Mini-CAS</u>	$\bar{X} = -1.8 \triangle 2$	$\bar{X} = -1.6 \triangle 2$	$\bar{X} = -7.1$	$\bar{X} = -1.9$
	SD = 1.7	SD = 3.1	SD = 6.7	SD = 3.5

$\triangle 1$  Expected  $\bar{X} = -4.5$  seconds, due to epoch phasing  $\frac{(3 \text{ sec})}{2}$  and  $\frac{2 \text{ threats } (3 \text{ sec})}{3 \text{ tries}}$ .

$\triangle 2$  Expected  $\bar{X} = -1.5$  seconds, due to epoch phasing.

\*Exception - Threshold Tau 1 for the Mini-CAS was determined from the Tau 1 threat line incorporated in the equipment, which has a zero-nmi offset and reciprocal slope of 25 seconds.

The display reliability, which relates to giving correct threat information to the pilot in an uninterrupted sequence from the start of a threat in the Tau 2 zone until the end of a threat, is given below.

<u>Type of Equipment</u>	<u>Percent Display Reliability</u>		
	<u>Tau 2</u>	<u>Tau 1</u>	<u>Tau 1 &amp; 2</u>
CAU vs. CAU	98.9	99.0	98.9
Mini-CAS vs. Mini-CAS	99.8	99.5	99.7
Mini-CAS vs. CAU	97.0	100	97.5

In order to participate in the T/F CAS community, an aircraft must initially obtain a synchronization and process as many resync updates as possible.

COMMUNICATIONS SYNCHRONIZATION RELIABILITY AND ACCURACY

<u>Type of Equipment</u>	<u>Synchronization</u>		<u>Percent Sync Received</u>	<u>Accuracy-Difference Statistics in <math>\mu</math>s</u>				
	<u>Chances</u>	<u>Processed</u>		<u>Maximum</u>	<u>Minimum</u>	<u>Range</u>	<u>Mean</u>	<u>Sigma</u>
CAU vs. CAU	22,420	20,807	92.81	0.55	-0.35	0.70	0.0165	0.1007
Mini-CAS (ACY) vs. Mini-CAS (Waterloo)	2,578	1,984	76.96	.45	- .25	.70	.0460	.1022
CAU vs. Mini-CAS	22,711	19,676	86.64	.75	- .75	1.50	.0542	.1214

From the above, the lowest percent sync received updates were from a local flight over Atlantic City (ACY) very high frequency omnirange radar (VOR) at NAFEC using Mini-CAS vs. Mini-CAS where a 77-percent update rate was received. A complete analysis of the results are contained in chapter 5.

CONCLUSIONS.

From the results it was concluded that:

1. The MDEC CAS equipments perform the collision avoidance function as described in ANTC 117.
2. The Tau 2 communications range for both CAU and Mini-CAS was sufficient for encounters based on the range rates tested and extrapolated to 1,200 knots.
3. There was satisfactory communications range for Tau 1 warnings.
4. The range and range rate accuracies were sufficient to establish an accurate track on the intruder.
5. The warning-time deviations from threshold Tau were considered adequate to avoid a collision under ideal conditions.
6. The display reliability gave a high reliability of correct threat information for pilot action.
7. The synchronization accuracy and reliability were more than adequate, with the exception of local flights using Mini-CAS versus Mini-CAS, where antenna shielding using the top antenna in proximity to the ground station presented problems.

CHAPTER I  
EQUIPMENT DESCRIPTION

GROUND STATION.

The ground station (figure 1-1) consists of two functionally identical channels. While the two may be separated, with each retaining most of the major time-keeping, time dissemination, communication, monitoring, and test functions of the dual-channel system, the normal mode of operation is the dual mode, in which one channel assumes the role of master channel, and the other, the role of slave channel. The functions of the master channel can be found in reference 3 and are the following:

1. Accept synchronization from a primary source by portable clock, satellite synchronization system, fly-by clock, ground-wave radio, etc.;
2. Maintain synchronization within  $\pm 0.5 \mu\text{s}$  between synchronization intervals with said primary source standard;
3. Synchronize all CAS-equipped aircraft within range, up to maximum of 1,936 aircraft (2,000 less 64 which are used for special purposes);
4. Radiate test signals for ground-based preflight tests of airborne CAS equipment;
5. Monitor time agreement between "internal" (i.e., own) and "external" (i.e., the slave channel's) cesium clocks and the ground epoch start triad. (Epoch start is received by slave channel via radiofrequency (RF) from the master channel, demodulated and verified by the slave channel, and hardlined back to the master channel.) Time comparison is also made between cesium clocks and other independent sources such as Loran-C ground-wave reception;
6. Monitor performance of synchronized aircraft;
7. Monitor performance of slave channel functions;
8. Monitor own performance through a series of built-in test (BIT) functions;
9. Inhibit transmissions when indicated and transfer the master channel function to the other working channel; and
10. Provide appropriate alarms when a failure is detected.

Functions of the slave channel are the following:

1. Accept initial time synchronization from the master channel;
2. Independently maintain synchronization to within  $\pm 0.5 \mu\text{s}$  of the master channel between updates;

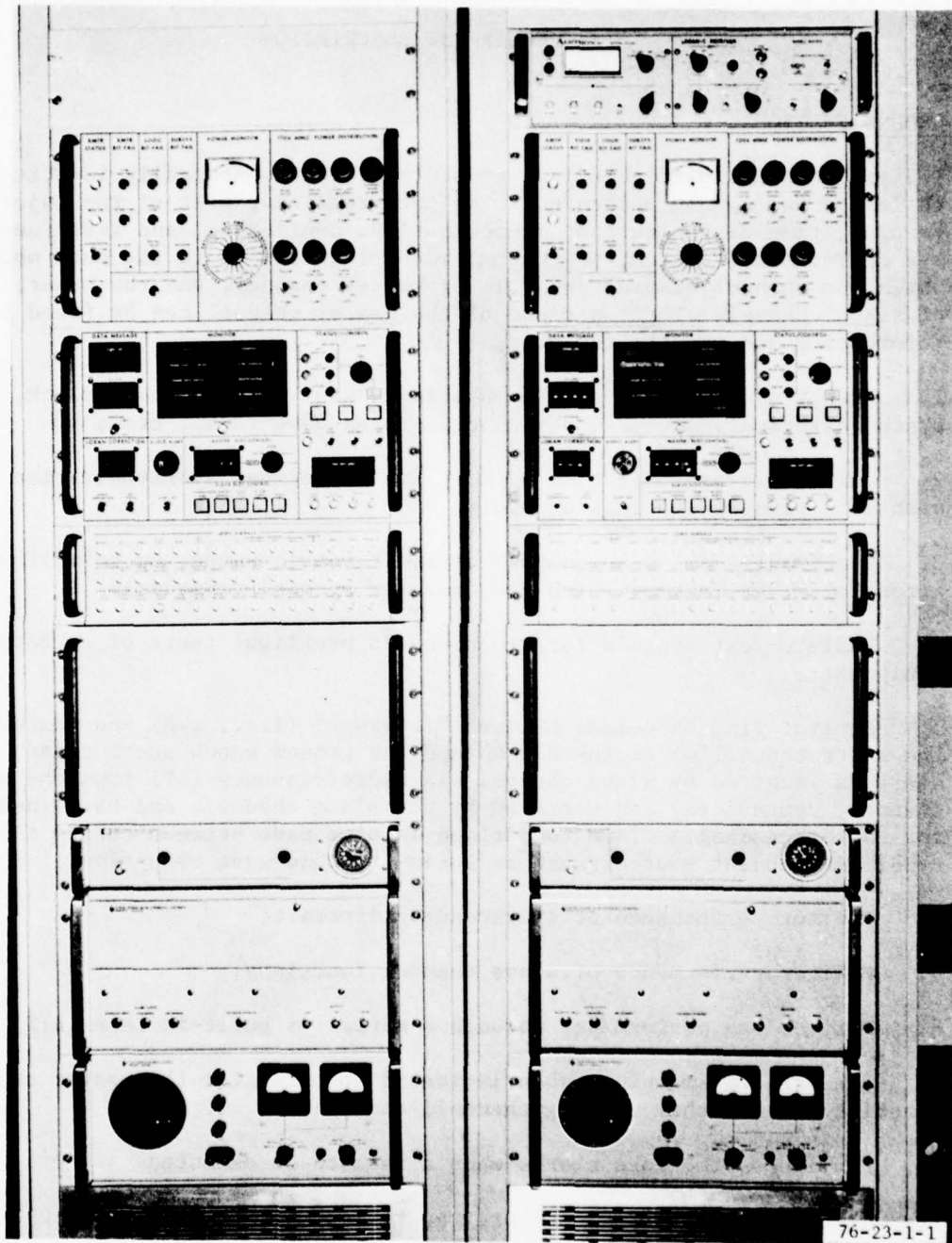

FIGURE 1-1. CAS GROUND STATION

3. Independently monitor time agreement between the online cesium clock and the standby clock; and, if used, another time source such as ground-wave Loran-C.
4. Receive and demodulate ground epoch start triads from the master channel and send hardline verification back to master channel;
5. Display test signals received from the master channels;
6. Display ground-slot transmissions;
7. Detect aircraft operating asynchronously or skewed in time;
8. Monitor performance of all slave channel functions through BIT functions and inhibit all slave channel transmissions (e.g., interrogations of skewed aircraft) when a failure is detected;
9. Provide suitable alarms in the event of failure; and
10. Automatically assume the master channel functions in the event of a master channel failure.

A block diagram of the system is shown in figure 1-2. System timing is provided by two digital clocks driven by cesium-beam frequency standards. Only one clock is "online" at any one time, the other being kept as a hot standby. A third independent standard, such as a Loran-C receiver, may be employed as a check. A two-out-of-three situation prevails, with at least two of the time sources having to agree within 0.5  $\mu$ s before the logic will activate the transmitters. Only a cesium-driven digital clock is ever used to control station timing; the third (Loran-C) is used solely for reference. The logic also controls the transmitter, exciter-receiver; and it is an integral part of the station's self-check feature, which is summarized in table 1-1.

The transmitter, which has a nominal peak power of 1 kilowatt (kW), is driven by the exciter. The exciter generates the biphase modulation (under logic control), local oscillator frequencies for the double-conversion receiver, a reference signal for calibration of the receiver's Doppler measurement circuits, and a pulsed, gated 25-megahertz (MHz) reference signal used by the transmitter to test the receiver subsystem.

The receiver, in addition to its usual functions of RF amplification, conversion, and demodulation, also demodulates nonreturn-to-zero (NRZ) biphase data and discriminates the intermediate frequency (IF) signals for monitoring the Doppler frequency shift.

The transmitter and receiver, which are isolated by a circulator, share a common antenna which consists of a vertical array of collinear-mounted dipole elements. The sections have an electrical length of one-half wavelength, and have their inner and outer conductors transposed at each junction. An inverted choke, one-half wavelength below the first gap, eliminates the need for a ground plane and prevents unwanted RF from traveling back down the feed cable. The top section contains a quarter-wavelength short, which is extended for lightning protection.

BEST AVAILABLE COPY

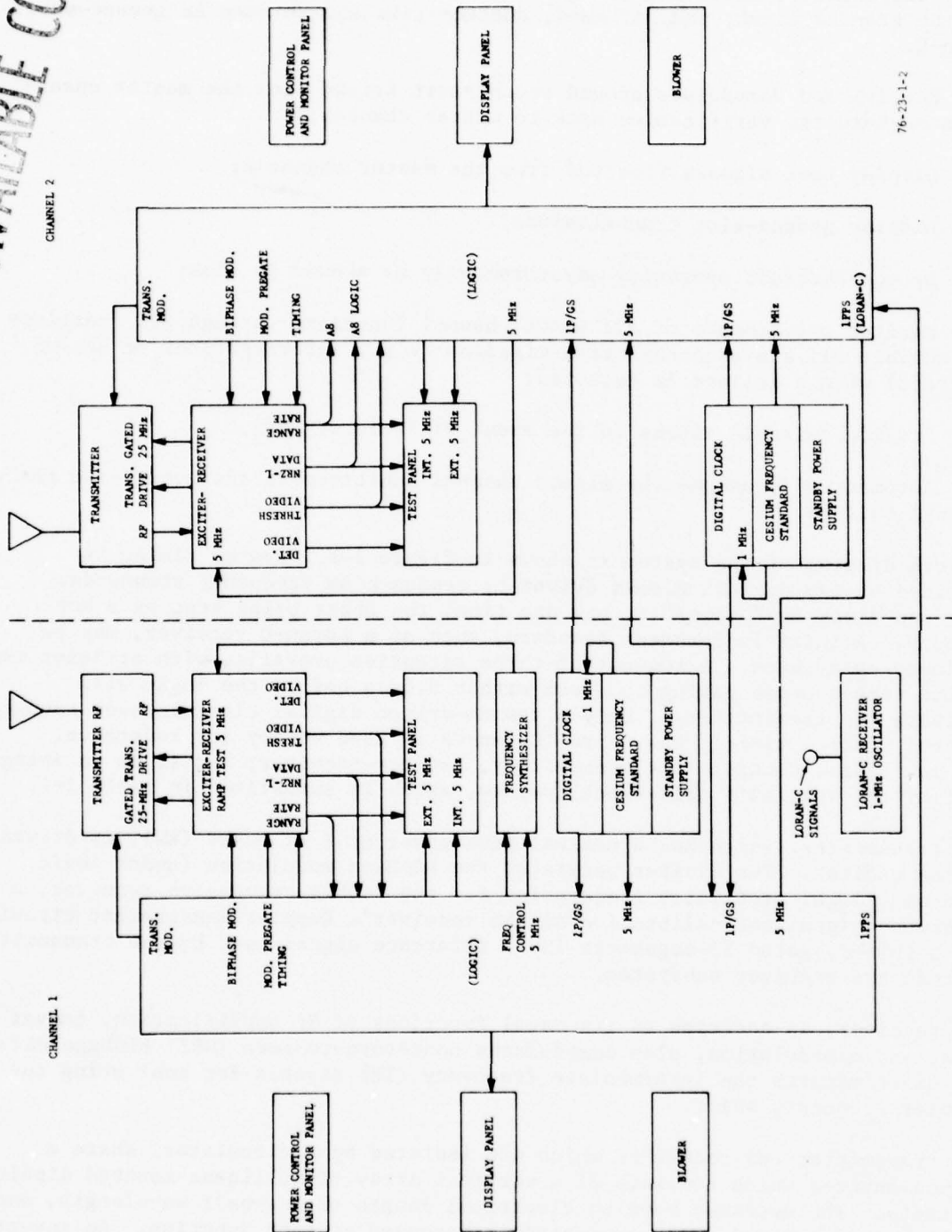

FIGURE 1-2. CAS GROUND STATION BLOCK DIAGRAM

TABLE 1-1. GROUND STATION BUILT-IN TEST (BIT) (REFERENCE 4)

Test Name	Description of Test	Result/Indication in Failed Channel																																
Channel GO/NO-GO	All BIT failures except RECEIVER also cause channel NO-GO indications.																																	
Internal Frequency Standard GO/NO-GO (Int Freq Std)	A 0.5-us pulse based on each frequency standard and a 0.1-us pulse based on the Loran receiver are compared for overlap. In the table, "A" means the frequency standard pulses overlap, "A" means no overlap; "B" means overlap of the internal standard and Loran pulses, "B" means no overlap; and "C" means overlap of external standard and Loran pulses, "C" means no overlap.	<p style="text-align: center;">Lamps</p> <table border="1"> <thead> <tr> <th>Comparison</th> <th>Loran</th> <th>Int Freq Std</th> <th>Ext Freq Std</th> </tr> </thead> <tbody> <tr> <td>ABC</td> <td>GO</td> <td>GO</td> <td>GO</td> </tr> <tr> <td><math>\overline{ABC}</math></td> <td>GO</td> <td>GO</td> <td>GO</td> </tr> <tr> <td><math>\overline{A}BC</math></td> <td>GO</td> <td>GO</td> <td>GO</td> </tr> <tr> <td><math>\overline{A}\overline{B}C</math></td> <td>NO-GO</td> <td>GO</td> <td>GO</td> </tr> <tr> <td><math>\overline{A}B\overline{C}</math></td> <td>GO</td> <td>NO-GO</td> <td>GO</td> </tr> <tr> <td><math>\overline{A}\overline{B}\overline{C}</math></td> <td>GO</td> <td>GO</td> <td>NO-GO</td> </tr> <tr> <td><math>\overline{A}BC</math></td> <td>NO-GO</td> <td>NO-GO</td> <td>NO-GO</td> </tr> </tbody> </table>	Comparison	Loran	Int Freq Std	Ext Freq Std	ABC	GO	GO	GO	$\overline{ABC}$	GO	GO	GO	$\overline{A}BC$	GO	GO	GO	$\overline{A}\overline{B}C$	NO-GO	GO	GO	$\overline{A}B\overline{C}$	GO	NO-GO	GO	$\overline{A}\overline{B}\overline{C}$	GO	GO	NO-GO	$\overline{A}BC$	NO-GO	NO-GO	NO-GO
Comparison	Loran	Int Freq Std	Ext Freq Std																															
ABC	GO	GO	GO																															
$\overline{ABC}$	GO	GO	GO																															
$\overline{A}BC$	GO	GO	GO																															
$\overline{A}\overline{B}C$	NO-GO	GO	GO																															
$\overline{A}B\overline{C}$	GO	NO-GO	GO																															
$\overline{A}\overline{B}\overline{C}$	GO	GO	NO-GO																															
$\overline{A}BC$	NO-GO	NO-GO	NO-GO																															
External Frequency Standard GO/NO-GO (Ext Freq Std)																																		
LORAN GO/NO-GO Standard GO/NO-GO																																		
High Voltage (HV) DELAY	Power to the high-voltage (HV) power supply in transmitter is inhibited until after filament power is applied and tubes are warmed up to operating temperature.	The "HV DELAY" light is ON until the delay has timed out.																																
Modulator ON (MOD ON)	The pulse-modulation signal from the logic to the transmitter can be enabled/inhibited by the MODULATION ON/OFF switch on the panel.	The "MOD ON" light is on whenever the switch is in the ON position.																																
Modulation Inhibit (MOD INH)	Transmitter modulation can be self-inhibited by the modulator for any of the following reasons:	<ol style="list-style-type: none"> <li>1. MOD INH light turned ON.</li> <li>2. If fault condition (2) thru (5) exists, logic will sense absence of forward power and cause "LOW FWD PWR" and "CHANNEL NO-GO" lights to turn ON.</li> <li>3. Pulsed audio alarm.</li> </ol>																																
	<ol style="list-style-type: none"> <li>(1) MODULATION ON/OFF switch in the OFF position.</li> <li>(2) Transmitter high-voltage supply senses overvoltage condition.</li> <li>(3) Malfunction in receiver monitor section of the transmitter.</li> <li>(4) Reflected RF power exceeds 300 watts.</li> <li>(5) Pulse modulator monitor detects excessive duty cycle.</li> </ol>																																	
Low Forward Power (LOW FWD PWR)	Transmitter RF power is supplied at the coupler in the antenna line. Transmitter monitor detects forward power and passes signal to logic if power exceeds threshold (approx. 300 watts). Logic checks for presence of signal each time range pulse is transmitted. Absence of signal (low forward power) four times in succession causes BIT to fail.	<ol style="list-style-type: none"> <li>(1) Channel NO-GO light ON.</li> <li>(2) Transmitter LOW FWD PWR light ON.</li> <li>(3) Transmission inhibited.</li> <li>(4) Pulsed audio alarm.</li> </ol>																																
High Reverse Power (HI REV PWR)	Reflected RF power is sampled at coupler in antenna line. If reverse power exceeds threshold (approx. 300 watts), transmitter monitor causes immediate lockout of pulse modulator to protect transmitter and receiver. Resulting loss of transmitter power also causes FWD PWR alarm.	<ol style="list-style-type: none"> <li>(1) Transmitter HI REV PWR light ON.</li> <li>(2) Transmitter MOD INH light ON.</li> <li>(3) Channel NO-GO light ON.</li> <li>(4) Transmitter "LOW FWD PWR" light ON.</li> <li>(5) Transmission inhibited.</li> <li>(6) Pulsed audio alarm.</li> </ol>																																
High (HI) Duty	Pulse modulator circuit continuously monitors input logic modulation signal. If duty is excessive (pulse width or repetition rate), high-power modulation is inhibited. Resulting loss of transmitter power also will cause logic to sense FWD PWR failure, if excess does not return to within normal maximum duty in several seconds.	<ol style="list-style-type: none"> <li>(1) Transmitter HI DUTY light ON.</li> <li>(2) Transmitter MOD INH light ON.</li> <li>(3) Channel NO-GO and transmitter LOW FWD PWR. Light ON and transmission will be inhibited if excess duty persists.</li> <li>(4) Pulsed audio alarm.</li> </ol>																																

TABLE 1-1. GROUND STATION BUILT-IN TEST (BIT) (REFERENCE 4) (Continued)

Range Pulse	Range pulse modulation (logic signal) is passed thru range verification logic. Four consecutive failures of any of the normal pulse-width checks results in a BIT failure.	<ol style="list-style-type: none"> <li>(1) Channel NO-GO light ON.</li> <li>(2) Logic RANGE PULSE failure light ON.</li> <li>(3) Transmission inhibited.</li> <li>(4) Pulsed audio alarm.</li> </ol>
Epoch Start (Master Channel Only)	Ground epoch start triad modulation (logic signal) is passed thru precise decoder to check format. Four consecutive failures of any of the format tests results in a BIT failure.	<ol style="list-style-type: none"> <li>(1) Channel NO-GO light ON.</li> <li>(2) Logic EPOCH START failure light ON.</li> <li>(3) Transmission inhibited.</li> <li>(4) Pulsed audio alarm.</li> </ol>
Resync Triad (Master Channel Only)	Ground resync triad (logic signal) is passed thru precise decoder to check for proper format and for precise time of reply. Four consecutive errors result in a BIT failure. In test slots, correct transmission time is also verified.	<ol style="list-style-type: none"> <li>(1) Channel NO-GO light ON.</li> <li>(2) Logic RESYNC TRIAD failure light ON.</li> <li>(3) Transmission inhibited.</li> <li>(4) Pulsed audio alarm.</li> </ol>
Timing	Logic continuous monitors (1) dropout of 5 MHz from selected frequency standard, (2) failure of own basic timing counter, (3) coincidence of $T_0$ and online frequency standard $1\mu/6s$ , coincidence of master and slave channel $T_0$ 's.	<ol style="list-style-type: none"> <li>(1) Channel NO-GO light ON.</li> <li>(2) Functional BI PHASE failure light ON.</li> <li>(3) Transmission inhibited.</li> <li>(4) Audio Alarm will be a steady tone.</li> </ol>
Receiver	Logic commands exciter to generate 25-MHz signal in test slot 1612. Signal causes step recovery diode in receiver monitor to produce 1600-MHz pulse (level approx -77 dBm which is coupled into receiver front end. Logic tests normal receiver threshold video output for weak signal sensitivity. (Test may also fail in presence of strong "on-frequency" jamming signal from external source, or if exciter generates incorrect transmit or local oscillator frequency.)	<ol style="list-style-type: none"> <li>(1) Functional RECEIVER light held 3 seconds for each BIT failure.</li> <li>(2) Flashing light indicates jamming.</li> <li>(3) Steady light indicates low receiver sensitivity.</li> <li>(4) Transmission is <u>NOT</u> inhibited.</li> <li>(5) Pulsed audio alarm.</li> </ol>
Master Slave Loop Fail	Transmitted epoch start triad from master channel is received by slave channel (via antennas). Thresholded video in slave channel is verified and a single pulse is returned to the master channel. Single failure results in BIT failure indication; however, transmission is not inhibited until one or more specific channel BIT failures (e.g., master channel transmitter, slave channel receiver, etc.).	<ol style="list-style-type: none"> <li>(1) Master channel functional MASTER SLAVE LOOP FAIL light ON.</li> <li>(2) Other BIT failure lights may be ON, depending on nature of problem in loop.</li> <li>(3) Pulsed audio alarm.</li> </ol>
HV Delay	Power to the high-voltage power supply in transmitter is inhibited until after filament power is applied and tubes are warmed up to operating temperature.	The HV DELAY light is ON until the delay has timed out.
Modulator ON (MOD ON)	The pulse modulation signal from the logic to the transmitter can be enabled/inhibited by the MODULATION ON/OFF switch on the panel.	The MOD ON light is on whenever the switch is in the ON position.
Modulation Inhibit	Transmitter modulation can be self-inhibited by the modulator for any of the following reasons: <ol style="list-style-type: none"> <li>(1) MODULATION ON/OFF switch in the OFF position.</li> <li>(2) Transmitter high-voltage supply senses overvoltage condition.</li> <li>(3) Malfunction in receiver monitor section of the transmitter.</li> </ol>	<ol style="list-style-type: none"> <li>1. MOD INH light turned ON.</li> <li>2. If fault condition (2) thru (5) exists, logic will sense absence of forward power and cause LOW FWD PWR and channel NO-GO lights to turn ON.</li> <li>3. Pulsed audio alarm.</li> </ol>

NOTE: BIT failures sensed only by the logic do not turn ON the MOD INH light; however, modulation input to the transmitter is inhibited to prevent erroneous transmissions, and the appropriate BIT fail light(s) will be turned ON.

The nominal gain in the horizontal plane is 8 decibels (dB), measured by MDEC. The station also has a frequency synthesizer and a Loran-C receiver which are physically mounted in the channel 1 rack and which are functionally shared by both channels. The synthesizer is used to generate frequencies which are used by the master channel in simulating Doppler signals for use during ramp tests. The Doppler capability, which was the original range-rate-determining parameter, has been retained in the present system, which also has the capability for discrete  $dR/dT$  ( $\Delta R$  over  $\Delta T$ ) range-rate determination. The Loran-C receiver is intended to be an independent time source.

The station also has the capability to accept synchronization from a fly-by cesium clock, and this capability was evaluated as part of the field acceptance test and reported in appendix A.

All of the station's vital parameters may be monitored by the operator by means of the power control/monitor panel (figure 1-3), display panel (figure 1-4), and test point panel (figure 1-5).

SYNCHRONIZATION SCHEME. Because T/F CAS is time-ordered (time-division multiplexed), it is necessary that all participants be synchronized to sub-microsecond accuracy. This is the primary role of the ground station. The CAU, but not the Mini-CAS, also has the capability of air-air synchronization of another CAU or Mini-CAS not in contact with a ground station. Except for minor differences, this process is essentially the same as via a ground station and will not be discussed further. Note that even a CAU must initially receive synchronization from a ground station before it can synchronize others.

As mentioned in the section on airborne units, the time-division multiplexing scheme consists of 3-second intervals (epochs) during which participants may be updated (figure 1-6). Every other epoch is reserved for the air-air synchronization process; therefore, the ground station may fully synchronize participants only once every 6 seconds, unless addressed during an air epoch.

Every epoch is divided into 2,000 time slots (CAS message slots) of 1,500  $\mu$ s each. Sixty-four are reserved for special purposes, such as transmission of test signals for equipment checkout, obstacle avoidance, and landing-aid messages, leaving 1,936 available for CAS participants.

The synchronization process occurs in two stages, coarse synchronization and fine synchronization. The former is enabled by the fact that the ground station transmits a precisely timed unique group of three pulses called a ground epoch start triad (figure 1-7) in CAS message slot 0000 during all odd-numbered epochs. The airborne unit aligns its clock to these triads (this may take several epochs) and is then coarse-synchronized (figure 1-8), with a time-base error equal to the one-way propagation time ( $T_p$ ).

Once the airborne unit is in coarse synchronization, it selects a vacant message slot (determined by monitoring) and transmits a CAS message (range pulse) back to the ground station. The ground station computes the range to the aircraft based on the one-way propagation time  $T_p$ , but since the airborne time base is at this point slow by  $T_p$ , the indicated range will correspond to  $2T_p$ , or twice the actual range.

BEST AVAILABLE COPY

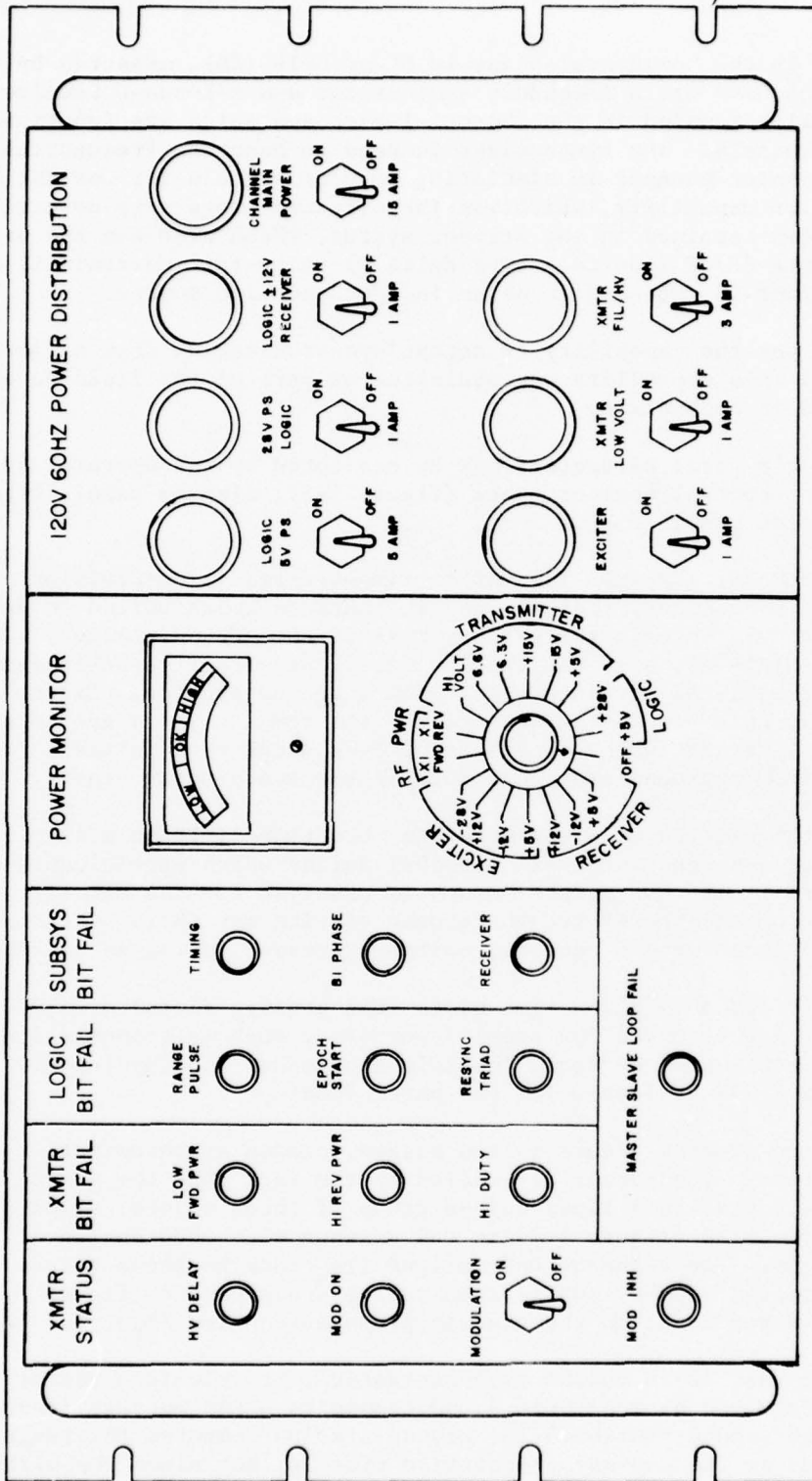

76-23-1-3

FIGURE 1-3. CAS GROUND STATION POWER CONTROL/MONITOR PANEL

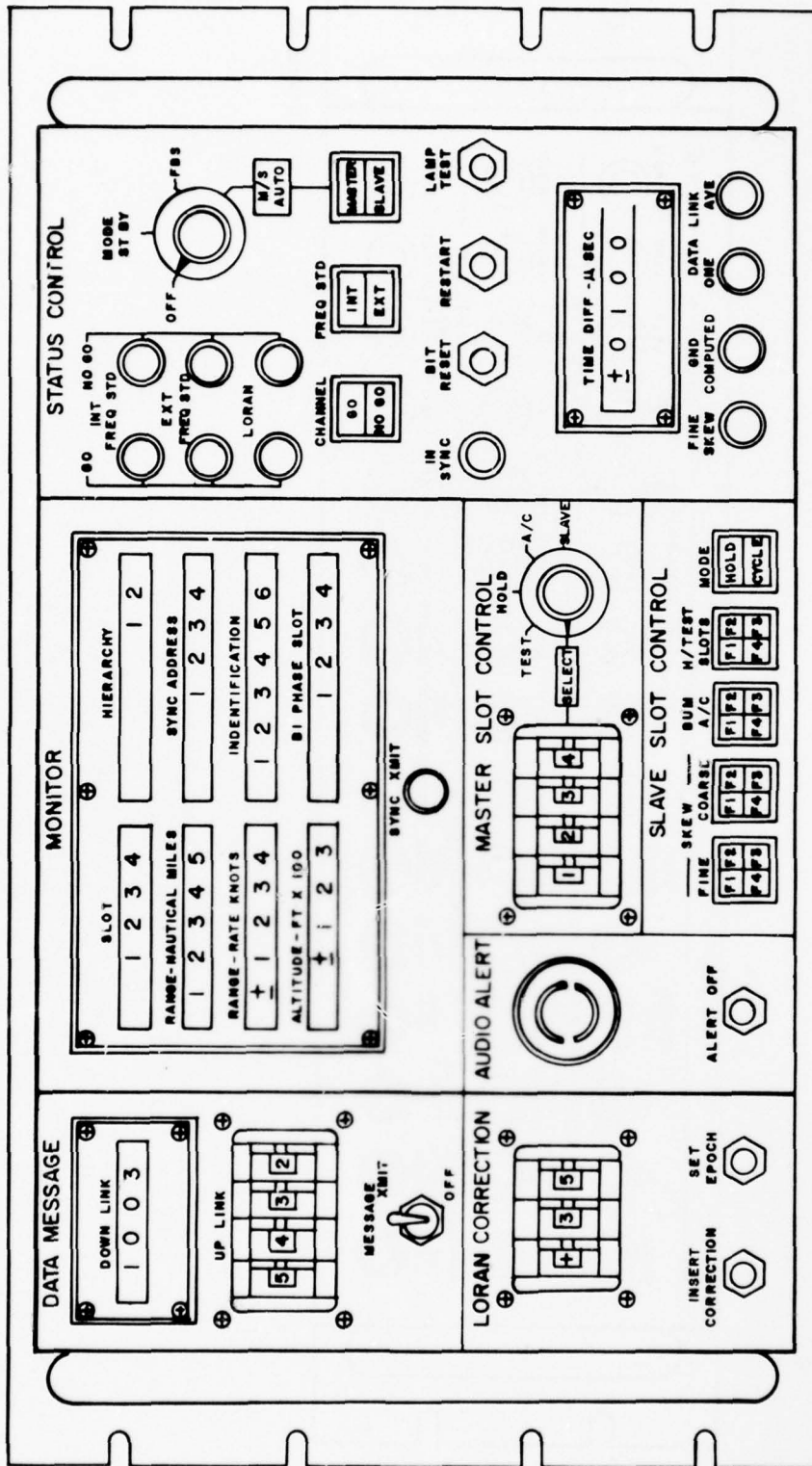
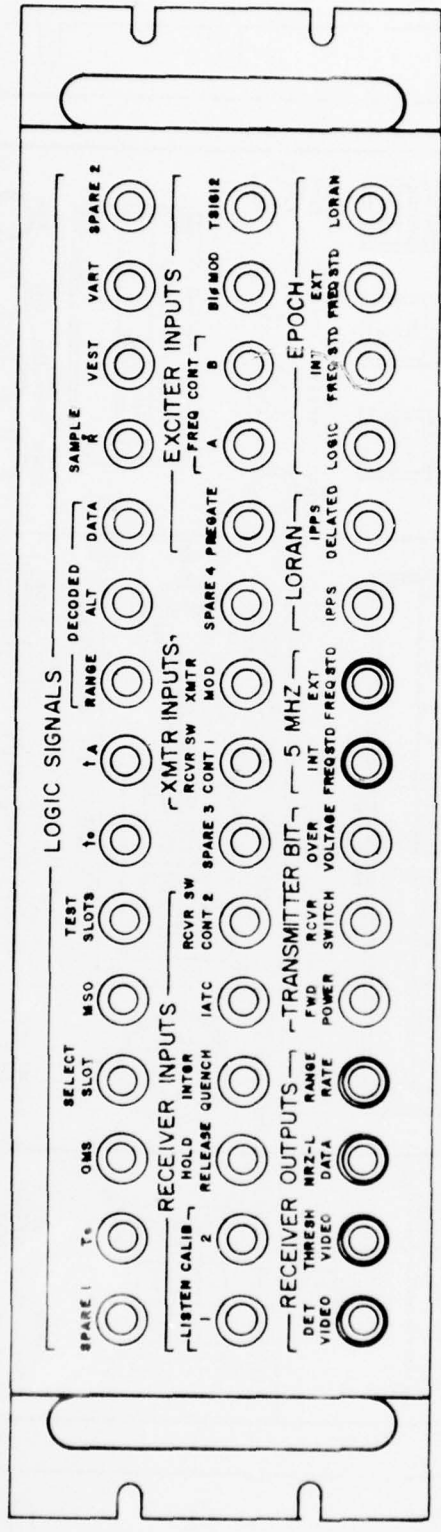

FIGURE 1-4. CAS GROUND STATION DISPLAY PANEL

BEST AVAILABLE COPY



76-23-1-5

FIGURE 1-5. CAS GROUND STATION TEST POINT PANEL

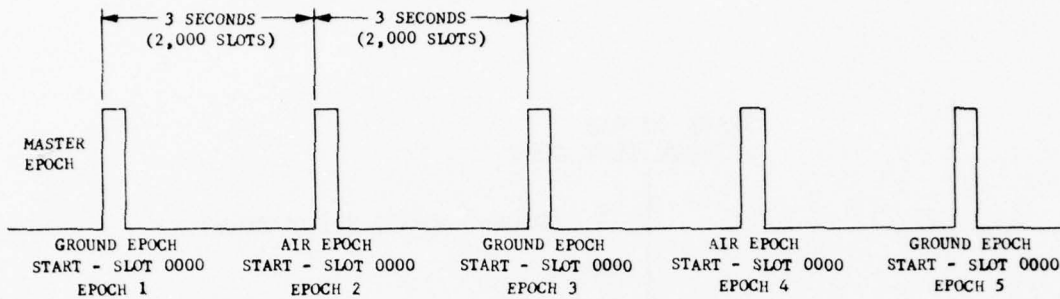
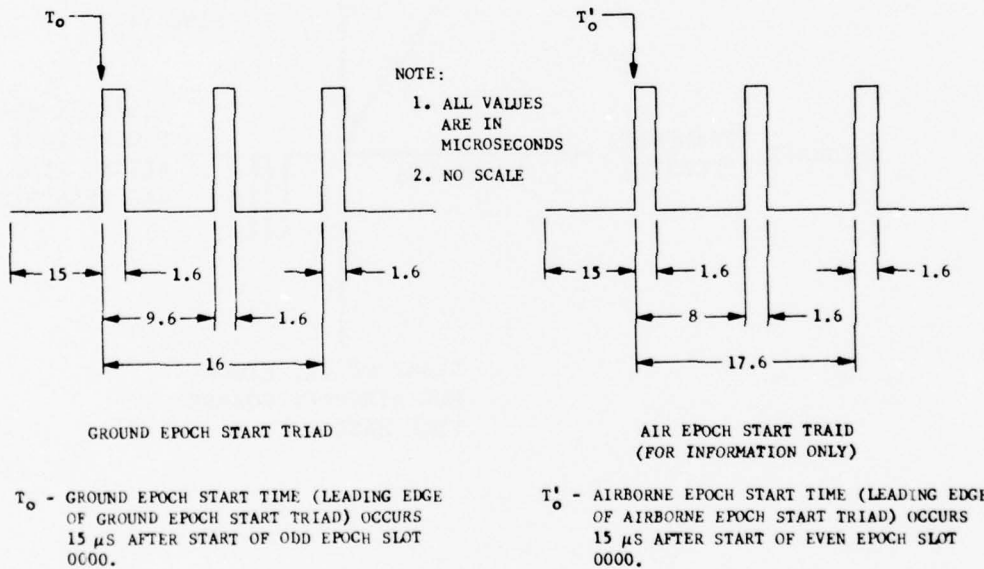
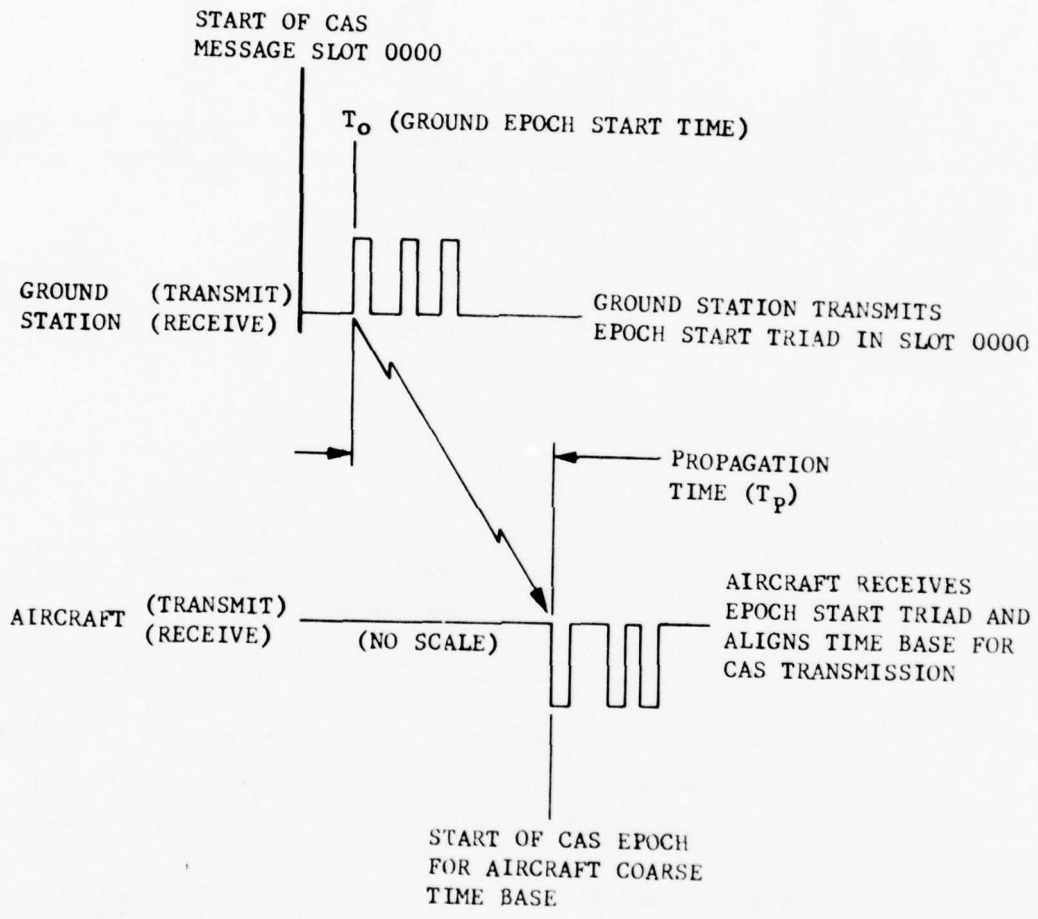

FIGURE 1-6. CAS EPOCHS



76-23-1-7

FIGURE 1-7. EPOCH START TRIADS



76-23-1-8

FIGURE 1-8. COARSE SYNCHRONIZATION

The ground station then transmits a fine synchronization triad (figure 1-9), which is pretriggered to occur  $2T_p$  prior to a specific reference time ( $t_s$ ) (no-error synchronization time reference) within the CAS message slot. The airborne unit compares the time of receipt of this triad to its own clock's  $t_s$ , the time difference being equal to twice the synchronization error, and realigns its own clock accordingly. It is then in fine synchronization.

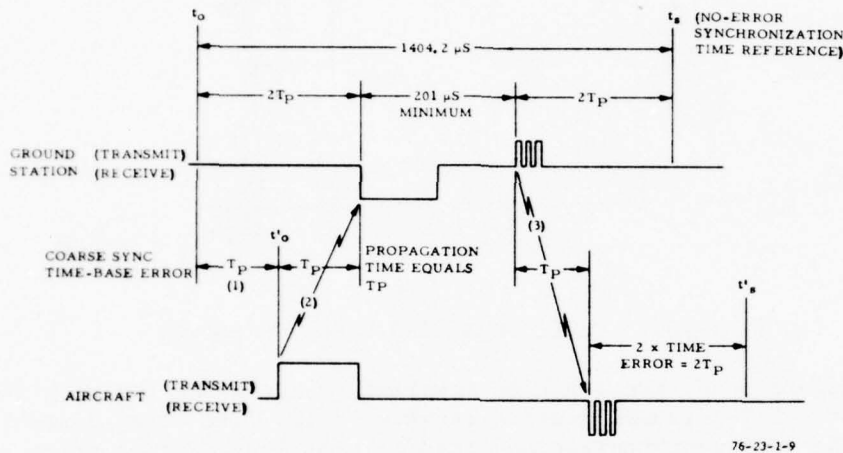

76-23-1-9

FIGURE 1-9. INITIAL FINE SYNCHRONIZATION

Referring to figure 1-9, an aircraft in coarse synchronization has a time base that is late by  $T_p$  (1). It transmits range pulse in selected slot (2). The ground station therefore receives range pulse  $2T_p$  after the correct start of slot ( $t_o$ ) and transmits back fine synchronization triad (3) which is pre-triggered to occur  $2T_p$  prior to no-error synchronization time reference  $t_s$ . The airborne unit measures arrival time of triad relative to own reference time  $t'_s$ . The difference is equal to twice the synchronization error, and the airborne unit realigns its clock accordingly to achieve fine synchronization.

The fine synchronization process continues indefinitely (figure 1-10), every epoch for the CAU and every other (i.e., every ground) epoch for the Mini-CAS. In either case, the fine time-base error  $\epsilon$  that has accrued in the airborne clock since the last resynchronization is reflected in the time that the range pulse is received by the ground station, and hence in the position of the fine synchronization triad that is transmitted back to the airborne unit. Since the airborne unit again compares the arrival time of the fine triad to its own  $t_s$ , it detects an error of  $2\epsilon$  and realigns its clock accordingly.

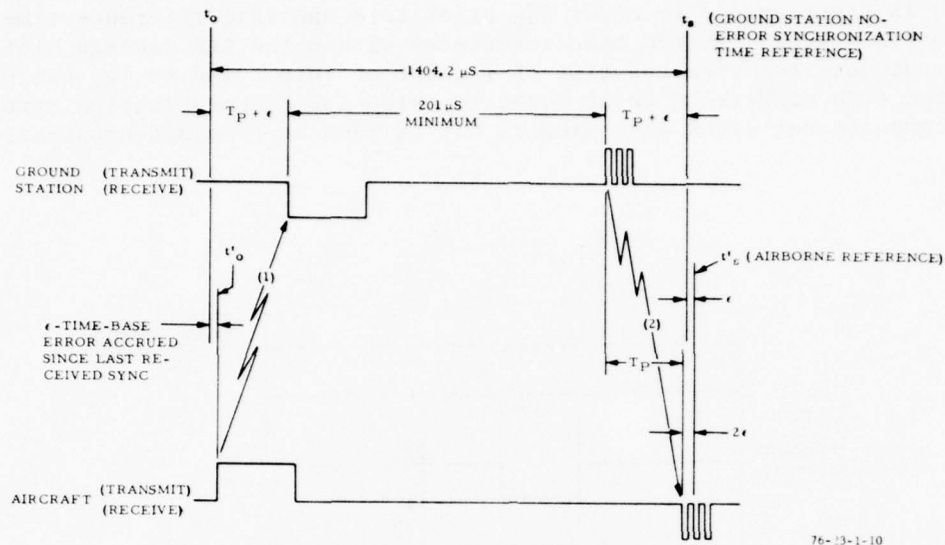

76-13-1-10

FIGURE 1-10. CONTINUOUS FINE SYNCHRONIZATION

In regard to figure 1-10, the aircraft transmits range pulse (1) with internal time base error  $\epsilon$ . The ground station receives pulse  $T_p + \epsilon$  after correct start of slot  $t_0$ . The fine synchronization triad is pretriggered  $T_0 + \epsilon$  prior to reference time  $t_s$ . The airborne unit receives triad  $2\epsilon$  prior to own  $t'_s$  and makes appropriate correction to own time base.

AIRBORNE EQUIPMENT.

INTRODUCTION. This section contains a brief description of the airborne T/F CAS equipment. The T/F is a cooperative time-division multiplex RF system designed to protect equipped aircraft against the threat of collision with any other similarly equipped aircraft. In dense traffic areas, the T/F concept provides interference-free data exchange for nearly 2,000 participants. The technique requires precise time synchronization and controlled frequency switching of air and ground equipment.

A network ground station synchronized to a single source of master time provides first-order synchronization support to all airborne units within communication range. Extension of ground station time is provided through time-hierarchy relay chains to all users equipped with Aeronautical Radio Inc. (ARINC) Characteristic 587 CAU's. Provisions are made in ARINC Characteristics 590 and ANTC report No. 117 for limited-level classes of cooperative equipment intended for use by small commercial airline, general aviation, and military users. One of the major simplifications in limited-level systems is the omission of the time-hierarchy function. These systems can obtain T/F synchronization from hierarchical systems, but cannot relay it to others. In less dense

traffic areas, not covered by ground stations and beyond the reach of the aircraft sync relay, CAS protection is provided by a secondary asynchronous mode (backup mode).

AIRBORNE EQUIPMENT. The airborne equipment supplied for the T/F CAS evaluation consisted of two CAU's, two dR/dT units, one set of FBS equipment, two Mini-CAS units, and associated maneuver indicators.

COLLISION AVOIDANCE UNITS. Two identical airborne CAU's were provided. These units are refurbished Engineering Model 2000 equipments which conform to ARINC Characteristic No. 587. The logic of both units is new and has been redesigned to incorporate new functions required for the evaluation program.

The new functions include (1) FBS (for air-to-ground synchronization of the ground station), (2) extended range sync (for nearly doubling the start-up and resync range of the ground-to-air link), and (3) dR/dT unit instead of internal Doppler measurement). All previously tested functions are retained, with a few improvements, in the new logic design.

dR/dT UNITS. dR/dT units were provided as "add-on" boxes for each CAU and are intended for use in evaluation of the dR/dT concept. The CAU will operate normally (using Doppler-derived range rate) without the dR/dT unit. When the unit is interfaced with the CAU and dR/dT mode is selected (switch provided on unit), the CAU utilizes the digitally derived range rate for Tau (range divided by range rate) computations. The digital range rate is computed by differencing successive range measurements (dR) and dividing by elapsed time (dT).

FLY-BY SYNC EQUIPMENT. One set of FBS equipment is provided for evaluation of the air-to-ground FBS technique. The equipment is designed to obtain master time by means of a portable clock from the U.S. Naval Observatory, maintain time while enroute, and transfer time to CAS ground stations via an RF link. Since the equipment utilizes one of the CAU's, it also operates cooperatively in the normal CAS environment with other CAS-equipped aircraft. Timekeeping is provided by an HP "flying clock" which consists of a cesium beam frequency standard and clock (with an improved beam tube) and a standby power supply (with nicad batteries). The FBS equipment is packaged on a special pallet and cabinet which includes a FBS Control Panel (simplified by contract modification to FAA Engineering Requirement).

MINI-CAS. Two identical airborne Mini-CAS units were provided for evaluation of limited-level CAS concepts for general aviation users. These units are modified versions of MDEC Micro-CAS feasibility models. The logic has been redesigned to include Tau threat logic based on the dR/dT range rate concept. The new logic was packaged as a flight-worthy breadboard in the Mini-CAS assembly. No attempt was made to miniaturize the design for flight test and evaluation of the Mini-CAS concepts.

CAS INSTRUMENT. Two sets of instrumentation were provided on loan by MDEC for the FAA CAS flight test. Each set is provided with cables to interface with either the CAU or Mini-CAS. The instrumentation contained digital displays and status lights for real-time monitoring of system performance.

A 35-millimeter (mm) camera recorded the display panel information. The camera was synchronized and pulsed by the CAS equipment such that one frame was recorded each 3-second CAS epoch.

MANEUVER INDICATOR. This unit is a combination CAS maneuver indicator and vertical speed indicator (VSI). The CAS command/advisory information is displayed to the pilot along with the aircraft vertical speed. Command information consists of flashing red symbols, while advisory information is provided in the form of yellow bands which establish vertical speed restrictions.

BASIC PRINCIPLES OF OPERATION AND FUNCTIONS. The primary functions of the airborne CAS are to detect and evaluate potential collisions and to indicate to the pilot a timely evasive maneuver (climb, level-off, or descend) or restriction (limit vertical speed and no-turn). Secondary functions include (depending on the class of airborne (ACAS) FBS service for the ground station, hierarchalsync service to other CAS's, obstacle avoidance, station-keeping, and distance measuring-equipment (DME) range to CAS ground stations.

All ground and air equipments employ the same basic time division multiplex and frequency switching techniques essential for T/F CAS operation. For a discussion on the terminology introduced thereon, such as time slot structure, signal-in-space, pulse and message formats, synchronization techniques, test messages, and other technical characteristics of the equipment refer to ANTC 117 (reference 2).

The instrumentation equipment operates with the ACAS to provide real-time monitoring and photographic recording of all displayed information.

MODEL 2000 CAS OPERATION/FUNCTION. The McDonnell Douglas Model 2000 CAS shown in figure 1-11 may be operated with or without the FBS equipment. On the FBS aircraft this is accomplished simply by selecting either CAS/FBS or CAS-only mode on the control panel. In the CAS/FBS mode, the CAU uses the precision frequency (5 MHz) of the flying clock to maintain time and is initially synchronized to the epoch time of the clock. The CAU remains in time-hierarchy 01 throughout its FBS mission. In the CAS-only mode, the CAU continues to use the precision frequency of the flying clock (simulating operation of the ARINC 587 precision frequency unit (PFU)); however, the epoch time of the clock is not used. Instead, the CAU must achieve time sync via the normal ground-to-air or air-to-air hierarchal resync process. In this mode, the CAU demotes in hierarchy at the normal "slow" rate of one step per 834 epochs (41.7 minutes) in the absence of a resync update. On the aircraft without FBS equipment, the CAU always operates in the normal CAS mode using its internal crystal oscillator. In the absence of resync update, the hierarchy demotes at the normal "fast" rate of one step per two epochs (6 seconds).

The CAU's are interchangeable and perform the following identical CAS functions:

1. To encode and transmit CAS signals to convey range, range rate, altitude, and time synchronization information to receiving stations.



76-23-1-11

FIGURE 1-11. COLLISION AVOIDANCE UNIT (CAU) AND MANEUVER INDICATOR

2. To receive and decode CAS signals transmitted by participating stations.
3. To provide two basic modes of CAS operation: Sync mode, using time-hierarchy, four frequency-multiplexing, and one-way threat evaluation; and Backup mode (BUM), using special interrogate-respond threat evaluation techniques when operating asynchronously. Obstacle avoidance is also provided, since it is an integral part of the existing design, but was not evaluated during this flight program.
4. To determine the extent of the collision hazard with respect to cooperating aircraft and to generate maneuver and advisory information (visual and aural) for the pilot.
5. To maintain time synchronization with respect to the most accurate source of time within communication range.
6. To transfer accurate time synchronization to other stations requiring such service.
7. To provide for automatic selection of the ARINC 587 PFU 5 MHz, when available, for the generation and protection of a more accurate time base, permitting longer operation in the sync mode in the absence of time update from other stations (not required when the "flying clock" is used).
8. To provide continuous integrity monitoring (BIT); to provide outputs to an airborne integrated data system (AIDS), when available; to provide data to a flight data recorder (FDR), when available; and to send commands to the maneuver recorder and FBS panel to indicate status, degradation, and failure.
9. To provide outputs for automatic test equipment (ATE) for use in fault isolation in the maintenance shop. These signals are used also for interface with the instrumentation.

CAU OPERATION AND dR/dT UNIT. The operation and functions of the CAU, when connected to the dR/dT unit, are unchanged from those described in the previous paragraph. The only difference is the technique by which range rate information is derived.

In the basic CAU, range rate is obtained by measuring the Doppler shift of the radio carrier frequency. This requires highly accurate and stable frequency generation throughout the entire transmitting and receiving subsystems (in addition to precise timekeeping logic for ranging and resync). Using the dR/dT concept, in which range rate is digitally derived by range differencing, the requirements placed on the RF subsystems are greatly relaxed. For this evaluation program, no change had been made to the RF hardware. However, in the dR/dT mode, the CAU utilizes the digitally derived range rate instead of the internal Doppler measurement for Tau-threat computation. When connected to the instrumentation, both types of range rate data are displayed for simultaneous comparison and evaluation. Threat displays and maneuver commands, however, will be the range rate (dR/dT) measurement technique in this test evaluation.

MINI-CAS OPERATION/FUNCTION. ANTC 117 and ARINC characteristic No. 590 provide for limited-level CAS's that omit as many complexities as possible while permitting use by aircraft flying at jet altitudes and speeds. The Mini-CAS provides a compatible system for subsonic aircraft whose performance constrains them to an altitude below 10,000 feet and altitude rates less than 1,000 feet per minutes (ft/min).

The Mini-CAS unit shown in figure 1-12 provided for the evaluation program is a modified version of early model Micro-CAS equipment. Micro-CAS threat logic was based on range and altitude computations only; however, the transmitted signal was controlled to the extent that receiving aircraft equipped with Doppler measurement circuits could compute Tau threats based on both range and range rate information. The modified Mini-CAS retains this so-called "coherent" transmission feature for use with the CAU which can process either Doppler or  $dR/dT$  range rate.

Mini-CAS incorporates the new  $dR/dT$  concept permitting it to use full Tau computations in the threat decision logic. Functionally, the Mini-CAS provides the essential characteristics of the ANTC 117 Limited-Level 2 system. Specifications for the Level 2 system have been revised slightly to reflect the performance of the Mini-CAS. The revised specification can be found in (reference 1) Mini-CAS specifications.

#### CAS/FBS THEORY OF OPERATION

MAJOR UNITS AND INTERFACES. A functional block diagram of the CAS/FBS airborne configuration is shown in figure 1-13. The diagram is arranged to show the line replaceable units (LRU's) as well as the major electrical interfaces.

LRU'S. The major LRU's of the CAS equipment are the following:

1. Collision Avoidance Unit (CAU),
2.  $dR/dT$  Unit,
3. Upper and Lower Antennas, and
4. Maneuver Indicator.

The additional LRU's which provide the FBS function are:

5. Frequency Standard/Clock,
6. Standby Power Supply,
7. FBS Control Panel,
8. 5-MHz Phase Shifter (Resolver), and
9. 5-MHz Buffer Module

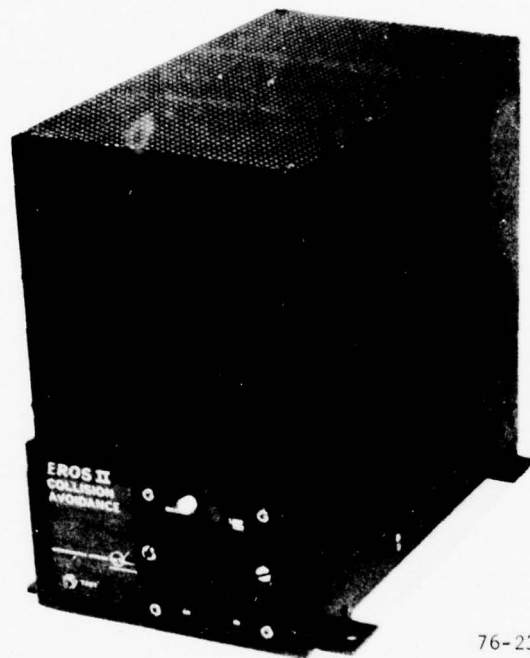

76-23-1-12

FIGURE 1-12. MINI-CAS

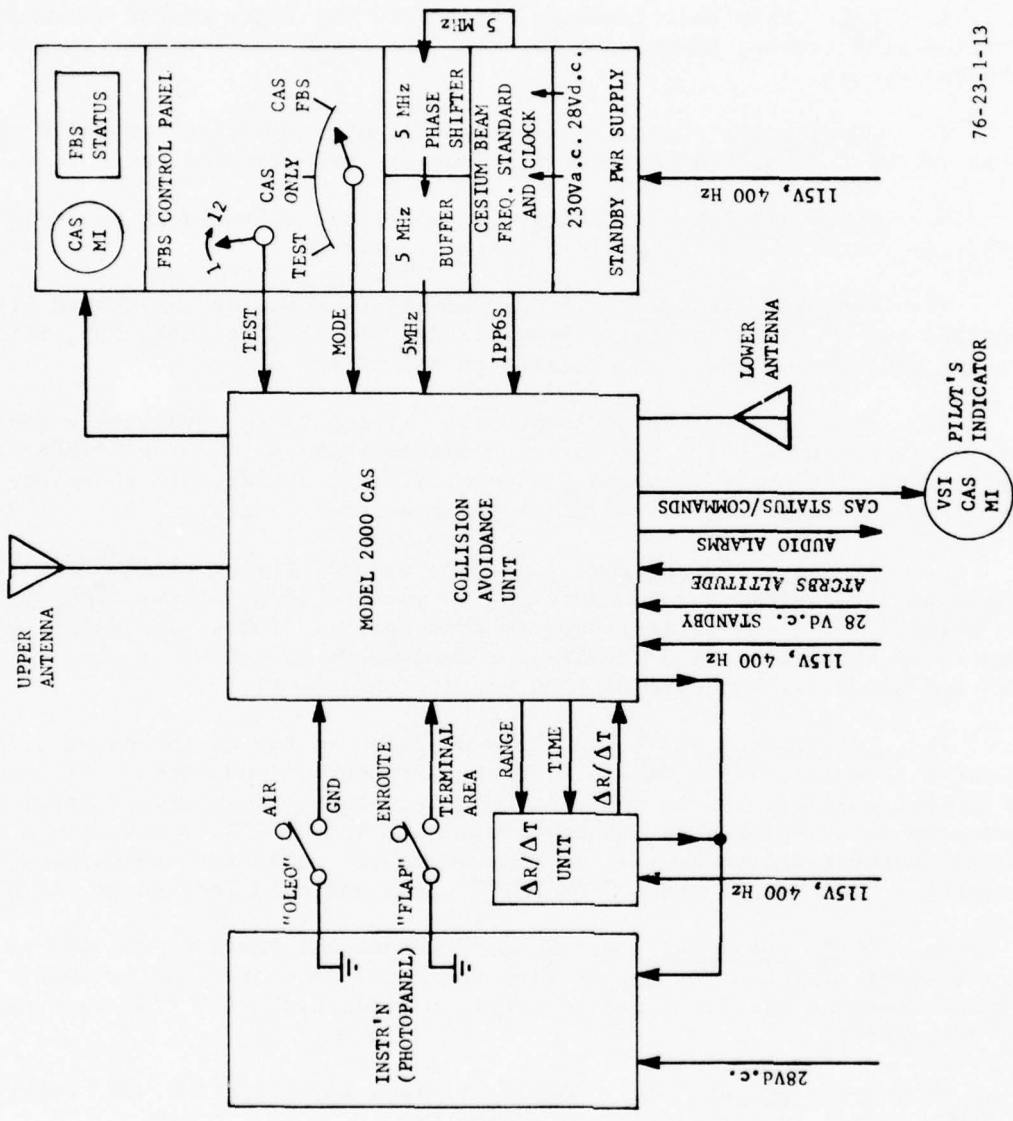

76-23-1-13

FIGURE 1-13. CAS/FBS FUNCTIONAL BLOCK DIAGRAM

The combination of the frequency standard/clock and standby power supply is sometimes referred to by the manufacturer, Hewlett-Packard, as the "flying clock." Instrumentation is also shown on the diagram to indicate interfaces.

#### GENERAL FUNCTIONS OF LRU'S.

1. CAU. This unit contains all of the CAS logic and RF assemblies which perform the timing, threat computation, and communication functions of the airborne system.
2. dR/dT Unit. Contains experimental digital circuitry which provides the CAU with an alternate means (to Doppler) for deriving range rate.
3. Upper and Lower Antennas. Antennas are switched in accordance with ANTC-117 rules to provide omnidirectional coverage.
4. Maneuver Indicator. A CAS indicator, normally integrated with the Vertical Speed Indicator (VSI), provides CAS mode status (OFF, BUM, SYNC) and evasive maneuver/advisory information to the pilot.
5. Frequency Standard/Clock. The "flying clock" contains a cesium beam frequency standard which generates an ultrastable and accurate 5-MHz output frequency. This frequency is counted down by digital dividers in the clock to produce an output occurring at one pulse per 6 seconds (1p/6s).
6. Standby Power Supply Also part of the "flying clock," the supply allows the frequency standard/clock to operate from various types of primary power (115 V, 400 Hz is issued in this installation). The supply also contains nicad batteries which provide for continuous operation of the standard and clock during interruptions of aircraft power.
7. FBS Control Panel. A three-position switch on the panel allows the operator to select TEST, CAS-ONLY, or CAS/FBS operational modes. A second switch on the panel allows the operator to select the various ground station test messages for display when the mode switch is in the TEST position. A second CAS Maneuver Indicator (MI) is mounted on the panel for convenience of the operator. Test points and a "FBS FAIL" light are also located on the panel.
8. 5-MHz Phase Shifter. A small mechanical resolver is used to adjust the phase of the 5-MHz output from the standard to the CAU so that final submicrosecond agreement can be obtained between the CAU time base and that of the clock.
9. 5-MHz Buffer. This module provides amplification and buffering of the 5-MHz signal from the standard to the CAU.

All of the major LRU's are discussed in more detail in the following paragraphs.

CAU. A functional block diagram of the CAU is shown in figure 1-14. The diagram is arranged to show the major assemblies as well as the major electrical interfaces within the CAU and to the other associated CAS/FBS equipment.

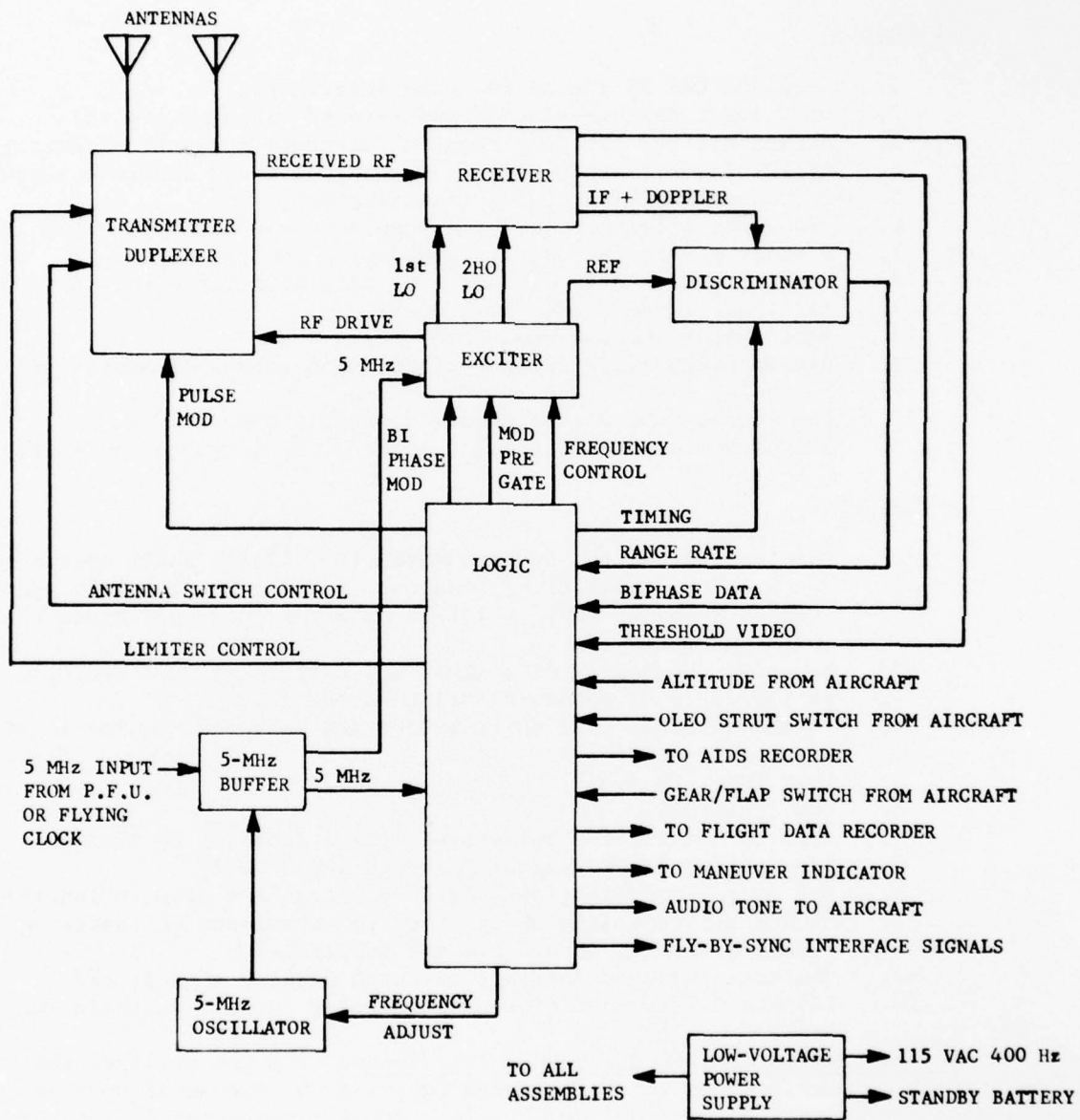

76-23-1-14

FIGURE 1-14. CAU FUNCTIONAL BLOCK DIAGRAM

CAU External Interfaces. The inputs and outputs are listed below and electrical characteristics are given in reference 4 and table 3-1. Signals listed below are used for bench testing and instrumentation.

CAU Inputs.

1. Received CAS RF signal (antenna interface),
2. Oleo strut switch--closed/open (ground airborne signal),
3. ATCRBS digital altitude signals (aircraft pressure altitude),
4. ATCRBS (uncorrected) failure warnings 1 and 2 (failure signal),
5. RF transmit inhibit (stop transmitting),
6. PFU 5-MHz (flying clock 5-MHz replaces airline-type PFU),
7. Standby power (28 V d.c., timekeeping power),
8. Identification data (18 parallel data bits for aircraft ident),
9. 115 V a.c.), 400 Hz (prime power),
10. Audio/visual test signal (from MI),
11. Approach/departure switch--closed/open (terminal area logic signal),
12. CAU enable (CAU ON/OFF remote control), and
13. Bright/dim signal (day/night control for indicator intensity).

CAU Outputs.

1. CAS command/caution aural warning (to pilot's audio system),
2. Maneuver commands (climb, descend, level off, no turn), and CAS ON (Sync or BUM) to flight data recorder and/or audible warning system,
3. Maneuver commands (CAS status, and caution signals (to MI),
4. 28 V d.c. to MI (audio/visual test output),
5. Power Amplifier (PA) power output (PA soft fail analog to AIDS),
6. Sync early (to AIDS),
7. Sync late (to AIDS),
8. BUM (to AIDS),
9. Internal oscillator adjustment limits (warning to AIDS),
10. Transmitted CAS RF signal (antenna interface),
11. 5-V d.c. Identity (ID) pull-up (voltage for open ID inputs)
12. ATCRBS altitude data OK (voltage for simulated GO condition when failure warning inputs are not available),
13. Obstacle avoidance/airport approach warning signal, and
14. 115-V a.c. switched (for antenna relay in dual installation).

CAU Instrumentation and dR/dT Unit Interfaces. The CAU utilizes the built-in ATE interface connector for operation with the McDonnell Douglas Instrumentation and the external dR/dT unit. The ATE connector is located at the rear of CAU.

In the McDonnell Douglas Model 2000 CAU, approximately 80 signals, including seven RF sampled signals, are routed to the ATE connector as a maintenance aid in bench testing. For the FAA flight tests, the signals available at the ATE connector are used for both the dR/dT unit interface and the McDonnell Douglas Instrumentation interface.

CAU Internal Assemblies and Interfaces. CAU internal assemblies and interfaces are depicted in the functional block diagram, figure 1-14. The CAU contains eight principal assemblies. The major functions of each principal assembly are described in the following paragraphs.

CAU Logic Assembly. The CAU logic assembly consists of eight plug-in cards, a mother board and a card rack. As shown in figure 1-14, the logic interfaces with all other assemblies of the CAU as well as various other CAS/FBS units and the aircraft. A simplified functional block diagram of the logic is shown in figure 1-15. The major functional blocks are described below:

1. Basic Timing Block. This block represents a counter which keeps track of air/ground epochs, message slots, and specific times within a slot. This timing information ( $t_0$ , MS000, etc.) is used in all of the remaining functional blocks. The time base is updated by time of arrival of verified ground or air resync (SYNC REC'D). Resync time of arrival is also used to adjust the frequency of the internal CAU oscillator by means of an eight-bit code (OSC ADJUST). In FBS mode, the time base is initially aligned by the 1p/6s input from the "flying clock." Thereafter, the time base alignment is maintained by counting down the same 5 MHz used by the clock. 1p/6s from the clock and 1p/6s from the CAU logic are continuously compared for agreement. (An FBS FAIL light provided on the FBS panel indicates when a time error exists.) In FBS mode, received air and ground resyncs do not adjust the CAU time base, or frequency, or the internal oscillator, because the "flying clock" is the master source.

Modulation signals for epoch start triads, in all sync modes, and own-range pulse are encoded directly by the basic timing counter.

2. Mode Control Block. The mode control determines three principal modes of operation:

1. Backup mode (BUM),
2. Sync mode (including "limited sync" and hierarchy sync"), and
3. Test mode (used only on the ground to process ground station test messages).

CAS frequency and antenna switching controls are dependent on the mode of operation and are outputs, respectively, to the exciter and transmitter/duplexer assemblies. Frequency and antenna switching are in accordance with ANTC 117 system logic.

Signal Decoding. Threshold video from the receiver assembly is processed by decoders in this block which classify and validate incoming CAS signals and reject interference and noise. The verified outputs (Rec'd range, altitude, BUM signals, and triads) are passed to the indicated blocks for timing and threat computation.

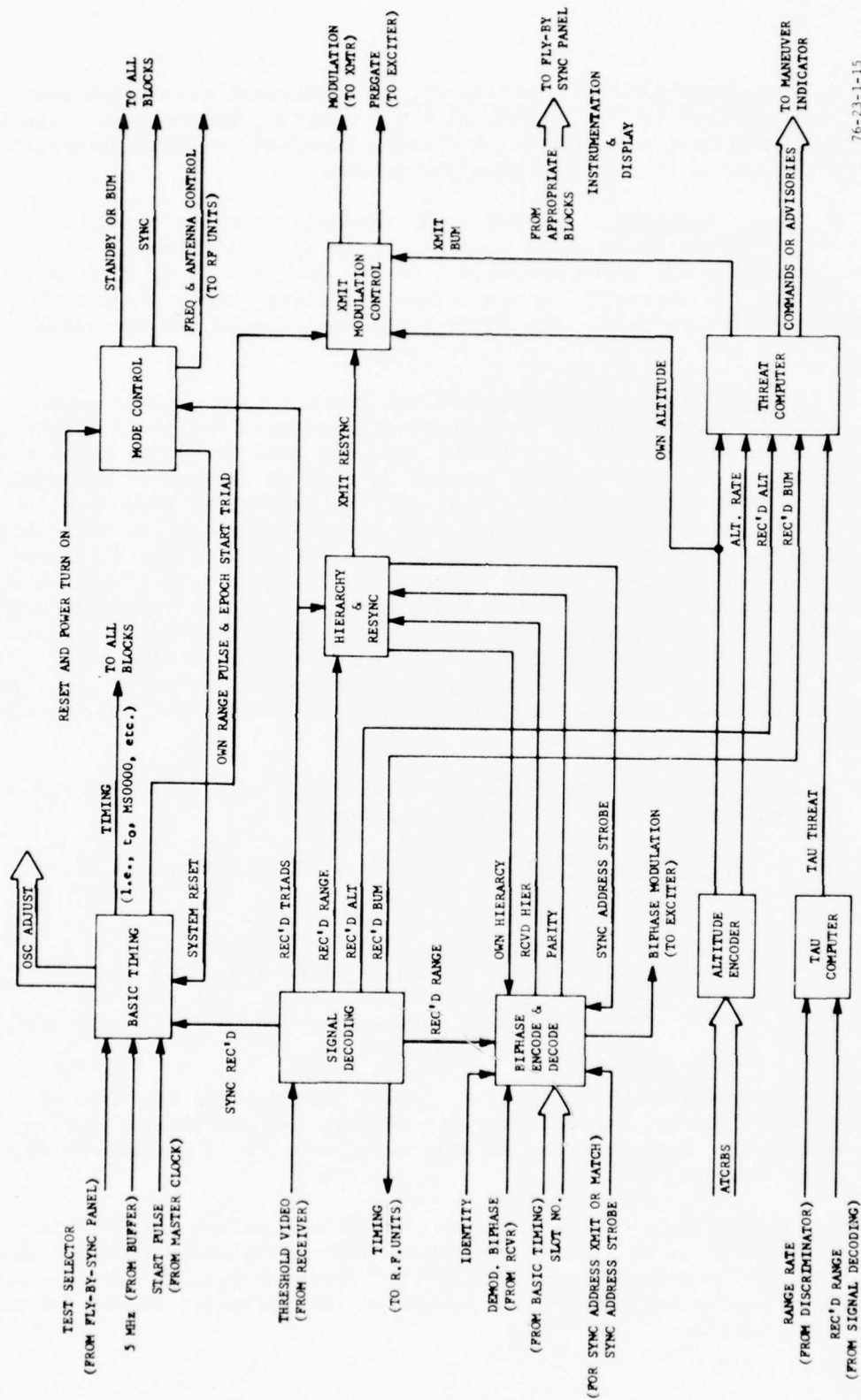

76-23-1-15

FIGURE 1-15. CAU LOGIC FUNCTIONAL BLOCK DIAGRAM

)

Biphase Encoder/Decoder. The encoding circuits convert NRZ-level data inputs (own-hierarchy, identity, slot No., etc.) to NRZ-space biphase modulation control of the exciter. Own-slot number is included in the biphase transmission to aid the ground station in detecting skew. The decoding circuits operate on the demodulated biphase data from the receiver. The data are converted from NRZ-space to NRZ-level format by the receiver demodulation process; therefore, the primary function of the logic decoding circuits is to identify the marker bit and clock the data bits properly for use in the hierarchy and resync logic. The encoder and decoder also generate parity bits for transmitted data and checks the parity of the received data.

Hierarchy and Resync. This logic keeps track of own-hierarchy status, demoting and updating as appropriate. Incoming data (received hierarchy and sync address) are used to determine whether to request sync (sync from address strobe) or supply sync (xmit resync) to the aircraft occupying the time slot. The hierarchy and resync logic operates in accordance with the general rules of ANTC 117, including the optional provision for extending startup range by advancing own-station time. (See ANTC 117, paragraph B-2.c(3).)

NOTE: The CAU logic which permits extended startup range should not be confused with the ground station logic implementation which increases the resync range of the ground-to-air link. This technique called "Extended Range Resync" requires special resync donor logic in the ground station and special processing logic in the airborne unit.

Altitude Encoder. The altitude encoder logic transforms the 11-bit ATCRBS input (from the aircraft) into a time positioned pulse transmitted after the range pulse in accordance with the CAS message format of ANTC 117. It also determines the altitude rate by monitoring the time between changes on the ATCRBS input. Own-altitude and altitude rate are supplied to the threat computer logic.

Tau Computer. This is an analog circuit which determines range divided by range rate (Tau) for each active data slot. The received range from the signal decoding logic is, in effect, divided by the received range rate to provide two outputs, "Tau - 25 seconds" and "Tau - 40 seconds" for use in the threat computer. Tau threat lines with range offsets are used per ANTC 117 and shown in figure 1-16. Range rate input may be supplied from either the internal discriminator assembly (Doppler measurement) or the external dR/dT unit (range/time, differencing measurement).

Threat Computer. Combinatorial decision logic in this block generates appropriate commands and advisory signals to drive the MI unit. Threat logic is in accordance with ANTC 117 criteria for both BUM and sync mode. As shown in figure 1-17 and figure 1-18 for low-altitude threat (below 10k feet) and high altitude threat evaluation output (above 10k feet) in figure 1-19.

Transmit Modulation Control. This is essentially an "OR" function which accepts the various logic signals (range pulse, altitude, triads, etc.) and produces the properly timed modulation signals for the transmitter. In

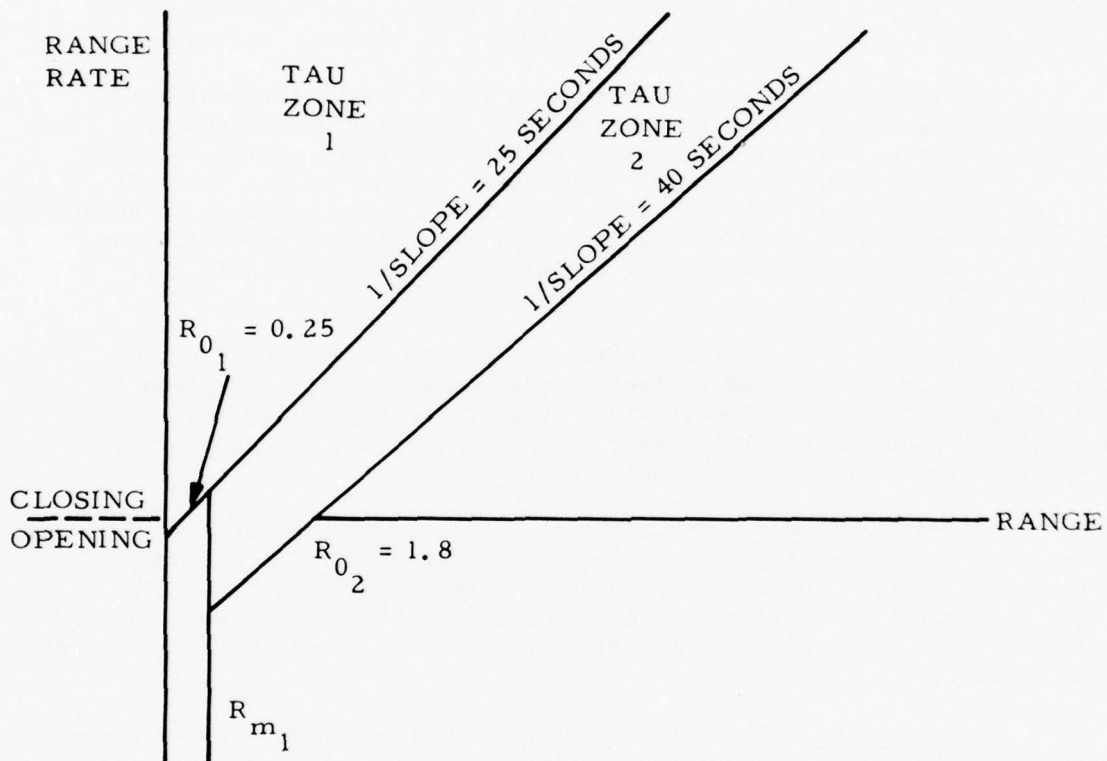

$R_{01} = 0.25 \text{ NMI} = 1,520 \text{ FEET}$   
 $R_{02} = 1.8 \text{ NMI} = 10,944 \text{ FEET}$   
 $R_{m1} = 0.5 \text{ NMI} = 3,040 \text{ FEET}$

76-23-1-16

FIGURE 1-16. RANGE AND RANGE RATE THREAT EVALUATION

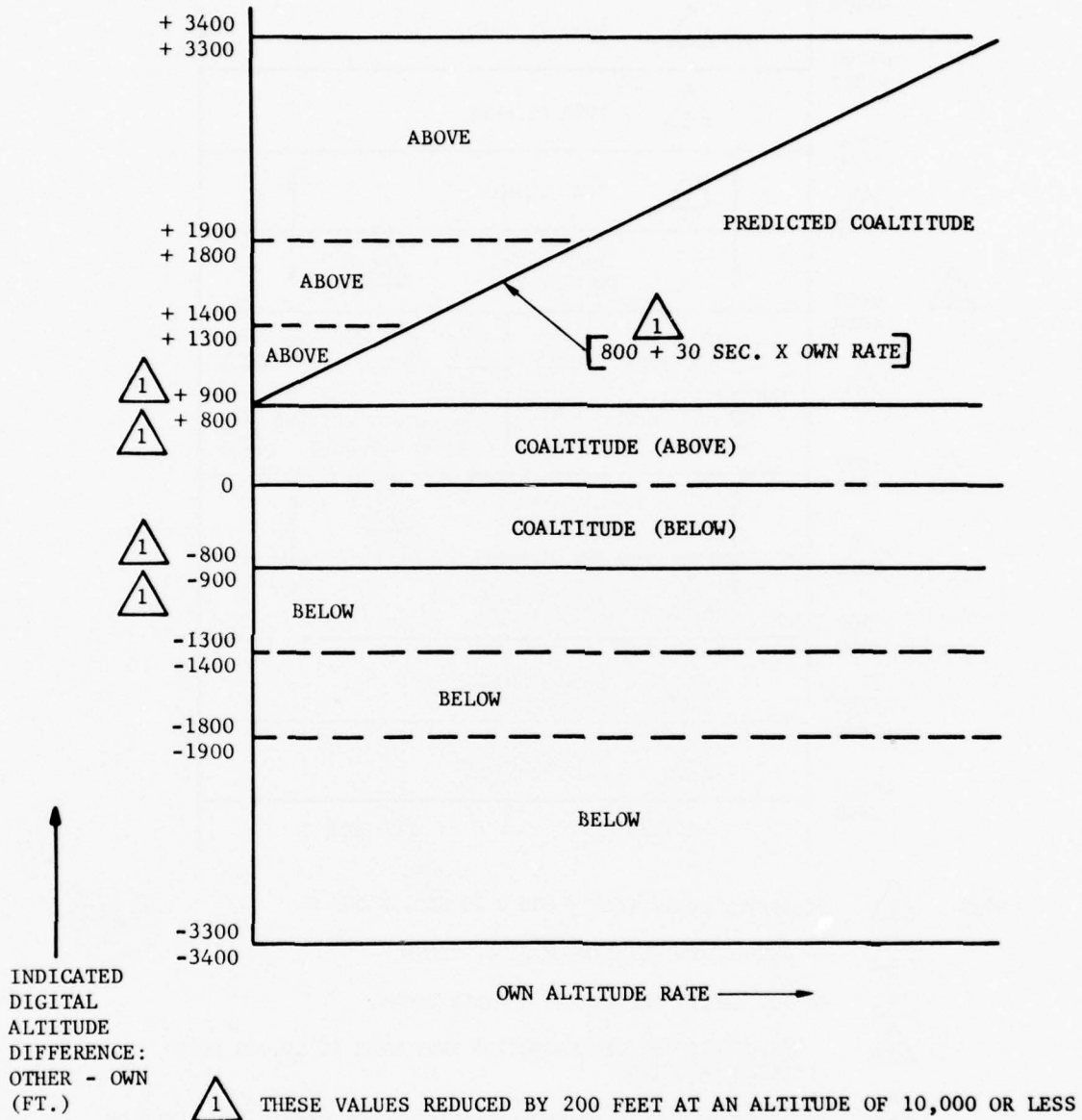

NOTE: PREDICTED COALTITUDE IS EXTENDED ONLY IN DIRECTION OF OWN ALTITUDE RATE. THIS FIGURE ONLY ILLUSTRATES OWN A/C ASCENDING.

76-23-1-17

FIGURE 1-17. THREAT EVALUATION ALTITUDE AND ALTITUDE RATE

INDICATED DIGITAL  
 ALTITUDE DIFFERENCE:  
 OTHER - OWN (FT.)

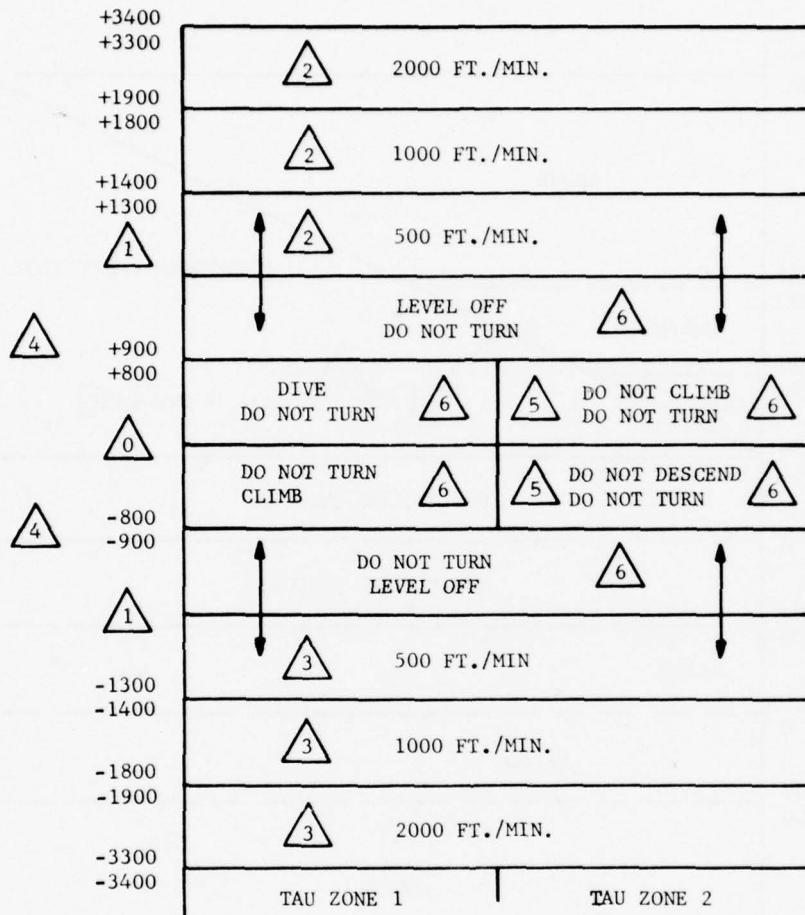

- NOTE:
- △1 PREDICTED COALTITUDE =  $800 + 30 \text{ SEC.} \times \text{OWN } \dot{H}$
  - △2 DO NOT EXCEED CLIMBING  $\dot{H}$  VALUE SHOWN.
  - △3 DO NOT EXCEED DESCENDING  $\dot{H}$  VALUE SHOWN.
  - △4 THESE VALUES ARE DECREASED 200 FEET WHEN AT 10,000 FEET ALTITUDE OR BELOW.
  - △5 COCKPIT DISPLAY OF A VERTICAL SPEED LIMIT WITHIN THE RANGE OF 0-400 FEET PER MINUTE IS ACCEPTABLE.
  - △6 RESTRICT BANK ANGLE TO  $\pm 10^\circ$  OR LESS

76-23-1-18

FIGURE 1-18. LOW-ALTITUDE THREAT/EVALUATION OUTPUT, TWO-AIRCRAFT ENCOUNTER

INDICATED DIGITAL  
 ALTITUDE DIFFERENCE:  
 OTHER - OWN (FT.)

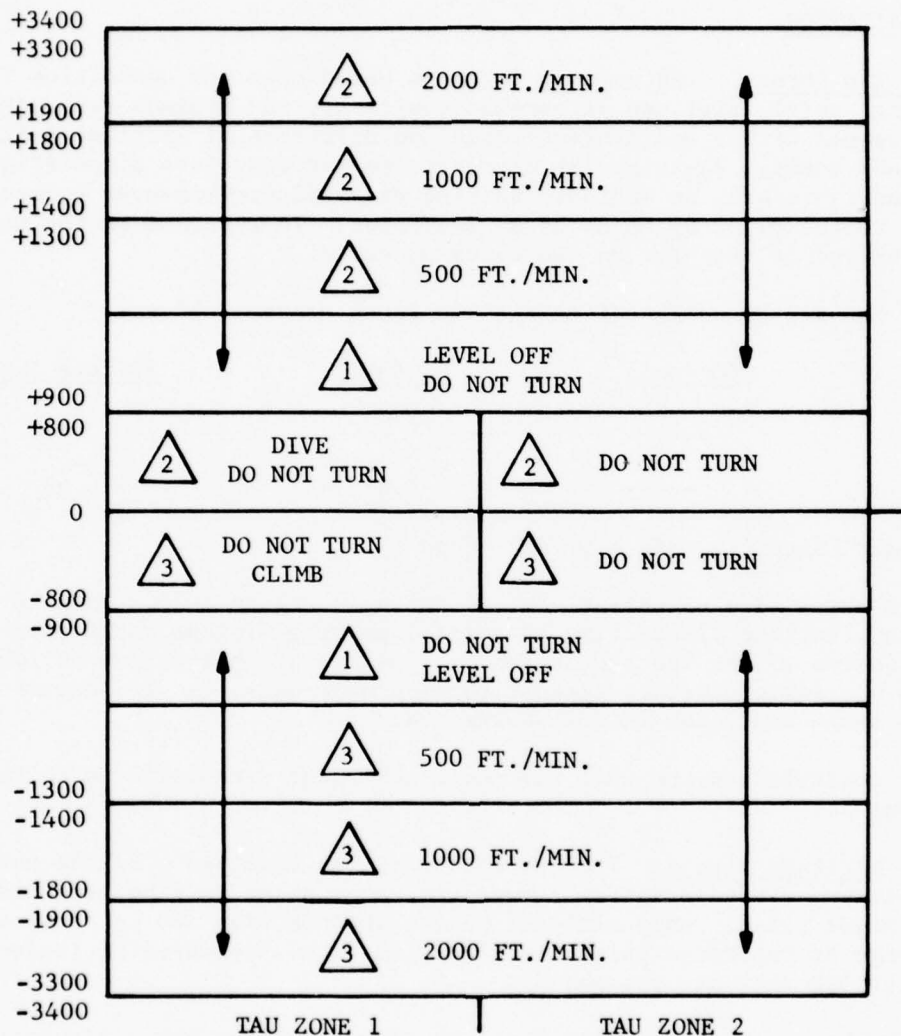

- NOTES: 1 LEVEL OFF IF EXCEEDING  $\dot{H}$  VALUE SHOWN.  
 2 DO NOT EXCEED CLIMBING  $\dot{H}$  VALUE SHOWN.  
 3 DO NOT EXCEED DESCENDING  $\dot{H}$  VALUE SHOWN.

76-23-1-19

FIGURE 1-19. HIGH-ALTITUDE THREAT/EVALUATION OUTPUT, TWO-AIRCRAFT ENCOUNTER

addition a pregate signal, which starts slightly ahead of and lasts throughout each modulation pulse train, is produced to gate "on" the exciter. This is done to ensure that the transmitter drive from the exciter is stabilized before pulse modulation is applied to the high-power amplifier in the transmitter.

THREAT EVALUATION.

1. Tau Threat. CAS warning logic is based upon the quantities Tau (range/range rate), altitude difference (delta h), and minimum range (Rm). Selected values of Tau and minimum range and differential altitude define Tau and altitude zones. An intruding aircraft, on entering into a specific altitude or Tau zone, initiates an advisory warning or avoidance maneuver command to be displayed to the pilot by means of an indicator. In response to the maneuver command, the pilot executes an avoidance maneuver.

Values of Tau and Rm which define the Tau zones are as follows:

<u>Tau Zone</u>	<u>Rm (nmi)</u>	<u>R<sub>0</sub> (nmi)</u>	<u>1/Slope (sec)*</u>
1	0.5	0.25	25
2	-	1.8	40

Rm = Minimum range      R<sub>0</sub> = Offset range

\*RH (right-hand) edge of threat zone as shown in figure 1-16. This is the slope of the line, not the linear time to collision. The minimum range zone is added as an extension of the Tau threat zone to insure safe separation at low closing rates, to provide protection against turning maneuvers, and to accommodate errors in range and range rate measurements.

No threat condition exists when the range and range rate point is to the right of Tau zone 2.

2. Altitude Threat. The CAU evaluates the received altitude data relative to own-altitude data. A received range pulse must be verified prior to an altitude pulse. Only altitude pulses which arrive 520 μs after the leading edge of the range pulse are processed (i.e., received altitude from -1k feet to 50k feet are processed).

On the basis of this evaluation, the CAU classifies the altitude threat status according to altitude difference bands as shown in figure 1-17. Coalitude bands include all values from zero to +800 when at high altitudes and from zero to +600 feet when at low altitudes. Above-below bands extend an additional 2,500 feet beyond the outer edge of the coalitude bands and are subdivided as shown in figure 1-17. The predicted coalitude band extends from the outer edge of the coalitude band in the direction of altitude rate when the rate is greater than 500 feet/minute. The height of this band is equal to own-altitude rate times 30 seconds. No altitude threat exists when the other aircraft is outside these bands.

Using the threat evaluation criteria, the equipment provides command outputs in accordance with the logic shown in figures 1-18 and 1-19 for two-aircraft encounters and figure 1-20 for three-aircraft encounters. To assure complementary maneuvers in all threat encounters, the transmitted altitude signal is biased when certain output commands are formulated and 400 feet or less of altitude separation is indicated. The bias is 200 feet in the direction of the following commands:

<u>Command</u>	<u>Bias</u>
Climb. Do not turn.	+200
Dive. Do not turn.	-200
Do not turn. Don't descend.	+200*
Do not turn. Don't climb.	-200*

\*This bias must not be used unless accompanied by a display to the pilot showing the direction of the imminent maneuver. At all other times, unbiased altitude data shall be transmitted. "Own" unbiased altitude data are always used on board for input into the threat evaluation logic.

Maneuver Indicator Display. This unit is a combination CAS, MI, and VSI (figure 1-21). The MI displays CAS status (OFF, BUM, Sync) and command/advisory information to the pilot. The VSI portion is a standard instrument currently used by airlines and meets the requirements of FAA Technical Specification Order TSO C8b.

The three-position flag mechanism indicates CAS operational status. Red and black diagonal stripes indicate CAS OFF. Yellow indicates BUM. Black indicates sync mode operation.

Commands consist of flashing red symbols which instruct the pilot to climb, descend, or level off. Red "no-turn" commands accompany each maneuver instruction. Advisory information is provided in the form of yellow bands which establish vertical speed restrictions if a target is Tau 2 or Tau 1. There are four lighted bands for climb restrictions, and four for descent restrictions. These limit vertical speed to 2,000 feet per minute, 1,000 feet per minute, 500 feet per minute, and 200 feet per minute. The pilot is instructed to keep the VSI needle out of any yellow band. For the case of noncoaltitude target, either one, two, or three yellow bands are energized depending upon the altitude difference. If the target is coaltitude, the fourth yellow band, limiting vertical speed to 200 feet per minute, is energized. This also energizes the no-turn lights.

The commands are red-lights (arrows) which instruct the pilot to climb, dive or level off. The climb and dive commands are energized if a target is coaltitude and Tau 1. There are two ways to energize the level-off command. First, there is the case of two coaltitude targets, both Tau 1, where one is above, and the other is below. Second, there is the case of a predicted coaltitude target Tau 1 or Tau 2.



$\Delta h \leq 3300$ ft Tau 2	Dive Do Not Turn LVS 0 fpm Up	Do Not Turn LVS 200 fpm Up	Level Off Do Not Turn LVS 500 fpm Up	Level Off Do Not Turn LVS 1000 fpm Up	Level Off Do Not Turn LVS 2000 fpm Up	Level Off Do Not Turn LVS 2000 fpm Up
Predicted Coalitude $\Delta h \leq 3300$ ft Tau 2	Level Off Do Not Turn LVS 500 fpm Up	Level Off Do Not Turn LVS 200 fpm Up	N/A	N/A	Level Off Do Not Turn LVS 2000 fpm Up	Level Off Do Not Turn LVS 2000 fpm Up
$\Delta h \leq 1800$ ft Tau 2	Dive Do Not Turn LVS 0 fpm Up	Do Not Turn LVS 200 fpm Up	Level Off Do Not Turn LVS 500 fpm Up	Level Off Do Not Turn LVS 1000 fpm Up	N/A	LVS 1000 fpm Up
Predicted Coalitude $\Delta h \leq 1800$ ft Tau 2	Level Off Do Not Turn LVS 500 fpm Up	Level Off Do Not Turn LVS 200 fpm Up	N/A	Level Off Do Not Turn LVS 1000 fpm Up	Level Off Do Not Turn LVS 1000 fpm Up	Level Off Do Not Turn LVS 1000 fpm Up
$\Delta h \leq 1300$ ft Tau 2	Dive Do Not Turn LVS 0 fpm Up	Do Not Turn LVS 200 fpm Up	Level Off Do Not Turn LVS 500 fpm Up	N/A	N/A	LVS 500 fpm Up
Predicted Coalitude $\Delta h \leq 1300$ ft Tau 2	Level Off Do Not Turn LVS 500 fpm Up	Level Off Do Not Turn LVS 200 fpm Up	Level Off Do Not Turn LVS 500 fpm Up	Level Off Do Not Turn LVS 500 fpm Up	Level Off Do Not Turn LVS 500 fpm Up	Level Off Do Not Turn LVS 500 fpm Up
Coalitude Tau 1	Dive Do Not Turn LVS 0 fpm Up	Do Not Turn LVS 200 fpm Up	Level Off Do Not Turn LVS 200 fpm Up	Level Off Do Not Turn LVS 200 fpm Up	Level Off Do Not Turn LVS 200 fpm Up	Level Off Do Not Turn LVS 200 fpm Up
Intruder Above	Dive Do Not Turn LVS 0 fpm Up	Dive Do Not Turn LVS 0 fpm Up	Level Off Do Not Turn LVS 500 fpm Up	Level Off Do Not Turn LVS 500 fpm Up	Level Off Do Not Turn LVS 500 fpm Up	Level Off Do Not Turn LVS 500 fpm Up
Intruder Above	Coalitude Tau 1	Coalitude Tau 2	Predicted Coalitude $\Delta h \leq 1300$ ft Tau 2	Predicted Coalitude $\Delta h \leq 1800$ ft Tau 2	$\Delta h \leq 1300$ ft Tau 2	Predicted Coalitude $\Delta h \leq 3300$ ft Tau 2

NOTE: LVS = "Limit Vertical Speed" to values listed.

(Sheet 2 of 2)

76-23-1-20b

FIGURE 1-20b. THREAT LOGIC OUTPUT, THREE-AIRCRAFT ENCOUNTER

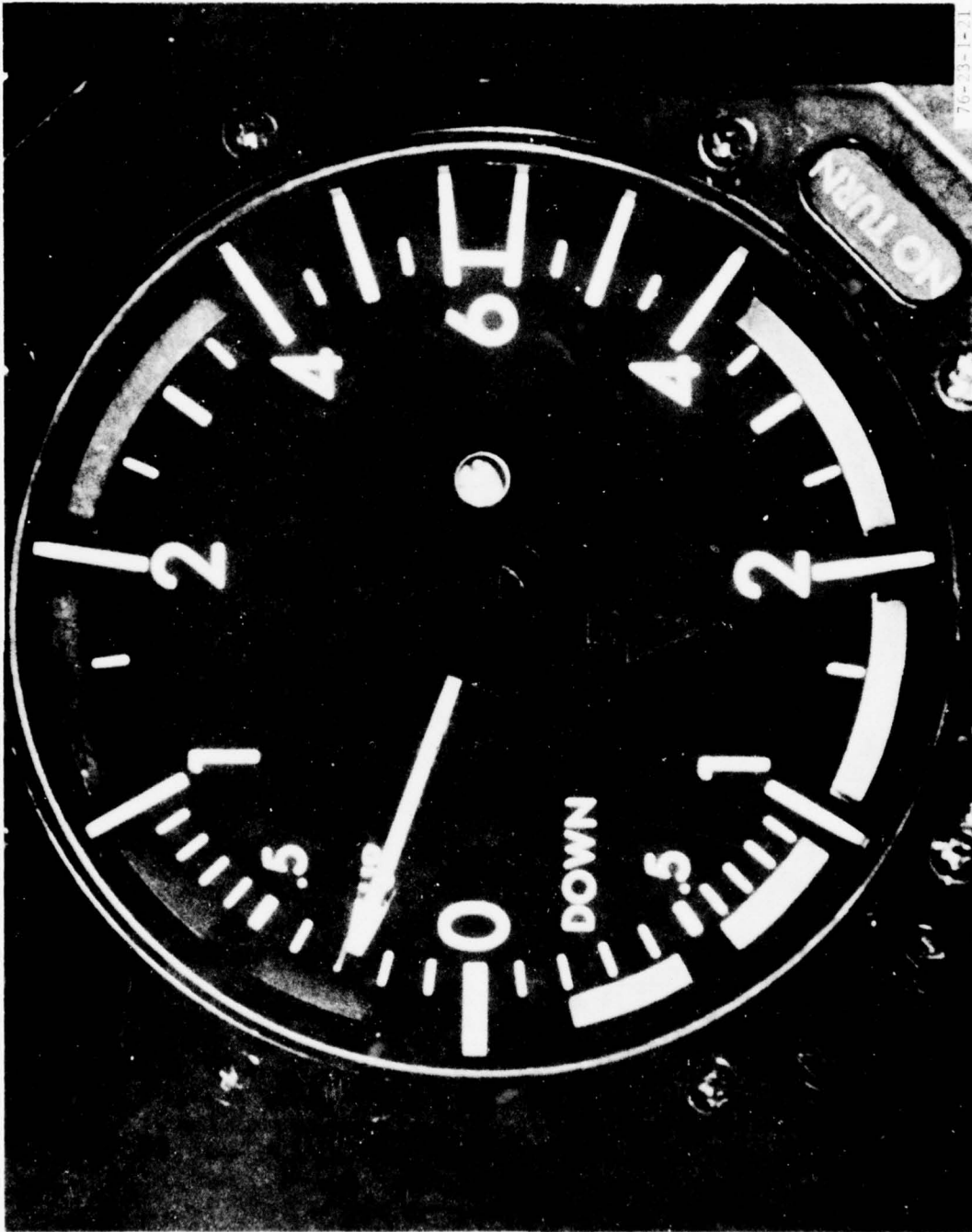

FIGURE 1-21. MANEUVER INDICATOR DISPLAY

Five maneuver commands used by the CAS are as follows:

1. Vertical Maneuver (Climb or Dive). This requires a rotation in the direction specified at an acceleration of not more than  $1/4$  g, but not less than  $1/8$  g up to a terminal climb or descent rate of 2,000 feet per minute or more until the maneuver command is terminated.
2. Hold Altitude. This requires remaining in level flight.
3. Level Off. This requires decreasing vertical speed to zero in not more than 10 seconds.
4. Do not turn. This requires return to linear flight in no more than 4 seconds; if not turning, a turn will not be initiated. "No turn" means do not exceed a bank angle of  $10^\circ$ .
5. Vertical Speed Restriction (limiting vertical speed to either 200 ft/min, 500 ft/min, 1,000 ft/min, or 2,000 ft/min). If the aircraft vertical speed exceeds the restriction, it must be reduced in not more than 10 seconds.

#### dR/dT UNIT.

This LRU operates with the Model 2000 CAS. Its function is to compute range rate (dR/dT) based on range data and timing inputs from the CAU. The dR/dT output is fed back to the CAU for use in the Tau threat computer logic and to the instrumentation for display and recording. A simplified functional block diagram is shown in figure 1-22.

The unit is capable of tracking and computing range rate for up to 256 active CAS-equipped aircraft within 15 nmi of own aircraft. The CAU logic checks each of the 2000 CAS time slots for valid range signals. Range data fed to the dR/dT are screened for  $R < 15$  nmi. This range boundary encompasses all potential 40-second Tau threat intruders at relative range rates up to 1,250 knots. It also includes adequate range to establish the first 3-second track (a 6-second track is used initially if 3-second data are not available). After the track is established, 6-second data are used when available to provide approximately 20-knot resolution. Otherwise, 3-second data are used to provide approximately 40-knot resolution. The output to the CAU is an analog voltage scaled at 250 knots/volt, linear from -5 V (1,250 knots, opening range rate) to +5 V (1,250 knots, closing). This voltage instead of the discriminator output, is used by the CAU when the dR/dT mode is selected (switch provided on dR/dT unit). A digital output provides closing range rate data to the instrumentation for display and recording.

UPPER AND LOWER CAS ANTENNAS. The CAS antenna radiates and receives signals in the assigned band from 1592.5 MHz to 1622.5 MHz. Two antennas are used with the CAU, one on top of the fuselage and one mounted on the bottom to provide omnidirectional coverage for large aircraft. Normally, the antennas are connected via coaxial cable to the upper and lower antenna input ports of the CAU. The logic switches the receiver and transmitter to the proper antenna in

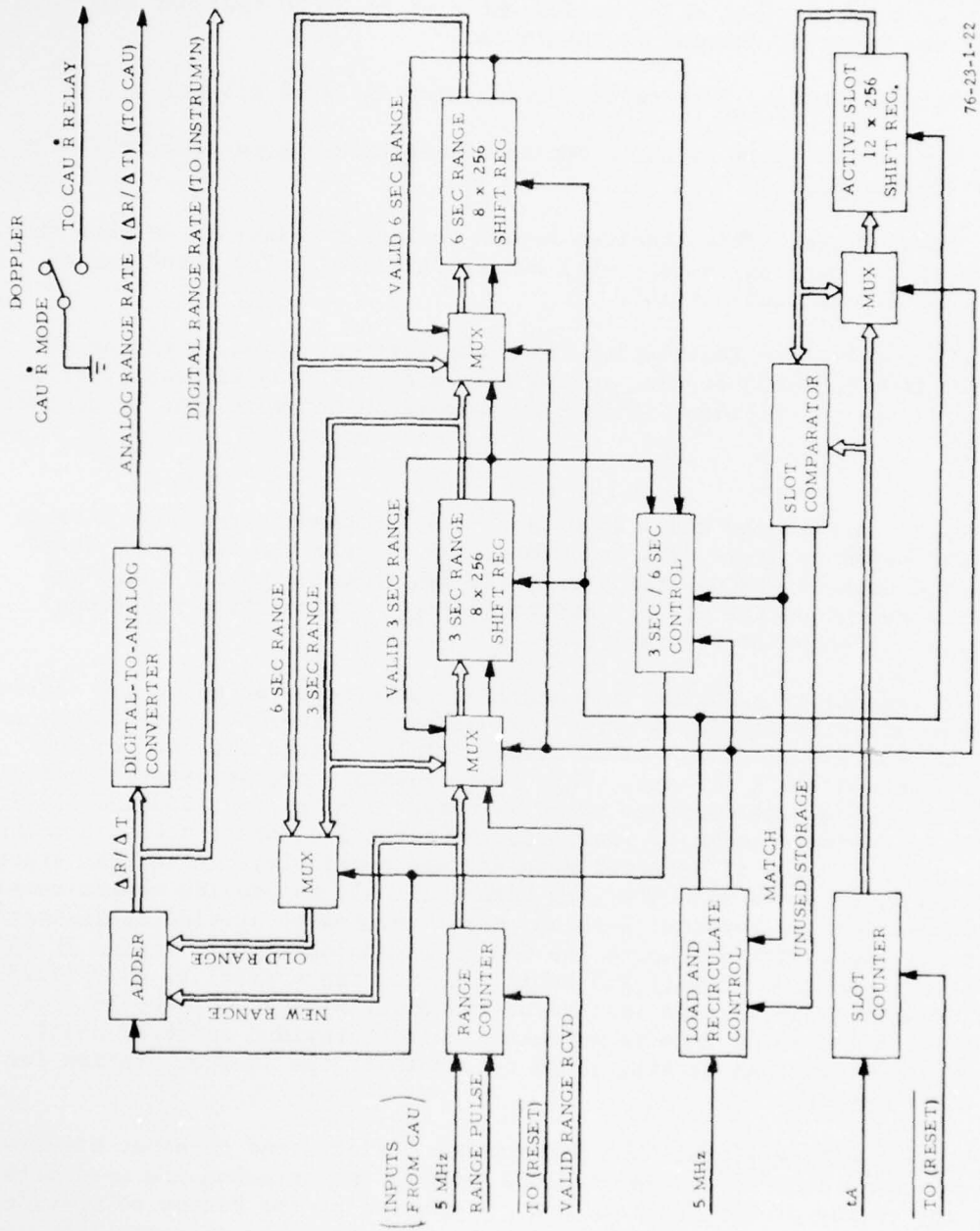

FIGURE 1-22.  $dr/dt$  UNIT FUNCTIONAL BLOCK DIAGRAM

accordance with ANTC 117 rules. For test purposes, a toggle switch is provided in the CAU to enable "lock-up" on the upper antenna only.

Each antenna has the following characteristics:

1. RF Power Handling: 2-kW peak, 6-W average
2. Impedance: 50 ohms at CAS frequency band
3. VSWR: 1.3 maximum, at CAS frequency band
4. Polarization: Vertical
5. Pattern: Within 1 dB of a matched quarter-wave stub.

The antennas have a built-in d.c. short which is sensed by BIT circuitry in the duplexer assembly of the CAU. This provides a simple method of determining that the antennas are connected and that no open circuits exist in the transmission line. A sensed "open" automatically causes the CAU to inhibit transmission, drop the "CAS-OFF" flag on the MI, and latch up the ANT BIT FAIL indicator on the front of the CAU.

#### EQUIPMENT SUMMARY SHEET.

##### GENERAL INFORMATION.

Equipment Type. Airborne Communication, Navigation, and Identification.

Equipment Function. Airplane Collision Avoidance.

Equipment Use. FAA Test and Evaluation.

Procurement Specification. Department of Transportation, Federal Aviation Administration Engineering Requirement, "Collision Avoidance System Ground Station," FAA-ER-240-016, October 1, 1971 (includes partial specifications for airborne equipments, modified by changes to contract DOT-FA73WA-3239).

##### Major Equipment Items.

McDonnell Douglas Model 2000 CAS (modified)  
Hewlett-Packard "flying clock" (modified)  
Fly-by-Sync control panel (simplified)  
Mini-CAS (modified Micro-CAS)  
Instrumentation (photopanel)

Assigned Frequency Band. 1592.5 MHz to 1622.5 MHz.

Operating Frequencies. 1600 MHz, 1605 MHz, 1610 MHz, and 1620 MHz, normally time division multiplexed.

Frequency Control. Cesium beam or crystal.

Modulation. Pulse (1.6  $\mu$ s to 200  $\mu$ s) and biphase (NRZ space at 500 kilobit/second burst rate for 120  $\mu$ s within the 200- $\mu$ s pulse).

Modulation Duty. One 200  $\mu$ s pulse per 3 seconds minimum; 0.0002 typical maximum; 0.003 lockout.

SPECIFIC EQUIPMENT INFORMATION.

1. McDonnell Douglas Model 2000 CAS (Modified).

Major Items.

Collision avoidance unit (CAU).  
Upper and lower antennas.  
Maneuver indicator (MI).  
dR/dT unit.

Function. Commercial airline CAS.

Airline Specification. Aeronautic Radio Corporation (ARINC)  
Characteristic No. 587.

Special Modifications. Fly-by sync, extended range resync, dR/dT unit for digital range rate, and instrumentation interface outputs.

System Frequencies Used. All (transmit and receive).

Frequency Control. External cesium beam or internal crystal.

Modulation. Pulse and biphase.

Power Output. 1,000 watts (W)  $\pm$ 3 dB.

Receiver Type. Double conversion superheterodyne.

Receiver Sensitivity. -88 decibels at 1 milliwatt (dBm), nominal.

Receiver Noise Figure. 8-dB, maximum.

Antenna. Vertically Polarized Stub.

Displays. CAS Status Flag and CAS Command/Advisories.

Power Requirements. 115 volts (V), 400 hertz (Hz), 3 amperes, maximum and standby. Timekeeping 28 V d.c. 2 amperes, maximum (CAU).

NOTE: dR/dT unit requires 115 V, 400 Hz, 1 ampere, maximum.

2. Hewlett-Packard (HP) "Flying Clock" (Modified)

Major Items.

Standby power supply model K02-5060A

Cesium beam frequency standard model 5061A, with Standard options 002 (30 minute battery) and 004 (improved beam tube, and special option H59 (001 clock option with special 1PP6S output.)

Function. Master clock for for fly-by-sync service

HP Specifications. (Also see HP manuals)

Accuracy:  $\pm 7 \times 10^{-12}$

Stability:  $\pm 1 \times 10^{-13}$

Long-Term Stability:  $\pm 3 \times 10^{-12}$  (for life of tube)

Warmup Time: 30 minutes

Standby Battery Operation: 30 minutes without main standby supply, 6 hours with main supply.

Outputs. 5 MHz, 20 milliwatts (mw), minimum, into 50 ohms 1p/6s, 4.7 V  $\pm 5$  percent (CAS epoch pulse).

Power Requirements. 115 V, 400 Hz, 1.5 amperes, maximum.  
(Aircraft input to standby power supply)

3. Fly-by-Sync Control Panel (Simplified).

Function. Mode control and display for fly-by sync (FBS) CAU

Mode Selection. Test, CAS-only, and CAS/FBS

Displays. CAS MI and FBS "FAIL" light.

Interface. CAU and Instrumentation.

Power Requirements. Provided by interfaces (aircraft power input not required.)

4. Mini-CAS (Modified Micro-CAS with dR/dT).

Function. General aviation CAS.

Specification. McDonnell proposal, March 18, 1974.

Special Modifications. dR/dT and Tau threat logic.

System Frequencies Used. Transmit 1605 MHz; receive all.

Frequency Control. Internal crystal.

Modulation. Pulse only (no biphase).

Power Output. 150 W  $\pm$ 3 dB.

Receiver Type. Single conversion superheterodyne.

Receiver Sensitivity. -78 dBm, nominal.

Receiver Noise Figure. 13 dB, maximum.

Antenna. Vertically polarized stub.

Displays. Standby/sync light and CAS command/advisories.

Power Requirements. 13  $\pm$ 1 V d.c., 5 amperes, maximum.

5. Instrumentation (Photopanel).

Function. Real time data display and photographic recording.

Interfaces. CAU or Mini-CAS, and aircraft.

Capacity. Two data slots (own aircraft and intruder).

Display Update Rate. Once per CAS 3-second epoch.

Recording Rate (Camera). One frame per epoch.

Displays.

- Own message slot number.
- Own hierarchy status.
- Own sync address.
- Own transmitted altitude.
- Own received resync time.
- Bogey message slot number (nonselected slot).
- Intruder range.
- Intruder transmitted altitude.
- Intruder hierarchy status.
- Intruder Doppler range rate.
- Intruder dR/dT range rate.
- Intruder sync address.
- CAS input/output status lights.

Controls.

Data slot selector switches.  
Oleo switch (simulates aircraft strut switch).  
Approach/departure switch (simulates flap switch).  
Transmit inhibit switch.  
Camera ON/OFF switch.

Power Requirements. 28 V d.c., 2 amperes, maximum.

## CHAPTER 2

### AIRCRAFT INSTALLATION AND FLIGHT TEST INSTRUMENTATION

#### AIRCRAFT EQUIPMENT INSTALLATION.

The three NAFEC aircraft used in the flight test evaluation were the Gulfstreams G159 (N376 and N377) and Convair CV880 (N42).

The N42 equipment installation (figures 2-1, 2-2, and 2-3) carried the following contractor-supplied equipment:

1. Collision avoidance unit (CAU),
2. dR/dT unit for the CAU,
3. Maneuver indicator (pilot and remote),
4. Antenna (upper and lower), and
5. ATRCBS altitude simulator.

The N377 installation (figures 2-4, 2-5, 2-6, and 2-7) carried the same equipment as N42 except as shown in figure 2-7, when a photoinstrumentation station was installed.

The N376 installation (figure 2-8) carried the following contractor-supplied equipment:

1. Mini-CAS (General Aviation unit)
2. Maneuver indicator--pilot (figure 2-9),
3. Antenna (upper),
4. Photoinstrumentation unit, and
5. ATRCBS altitude simulator

Aircraft equipment configurations were usually as the test dictated and usually followed these patterns:

#### Two-Aircraft (A/C) Flight

Aircraft:	N377 (A/C 1)	N376 (A/C 2)
Equipment:	CAU Mini-CAS CAU Mini-CAS	CAU Mini-CAS Mini-CAS CAU

#### Three-Aircraft (A/C) Flight

Aircraft:	N377 (A/C 1)	N376 (A/C 2)	N42 (A/C 3)
Equipment:	CAU	Mini-CAS	CAU

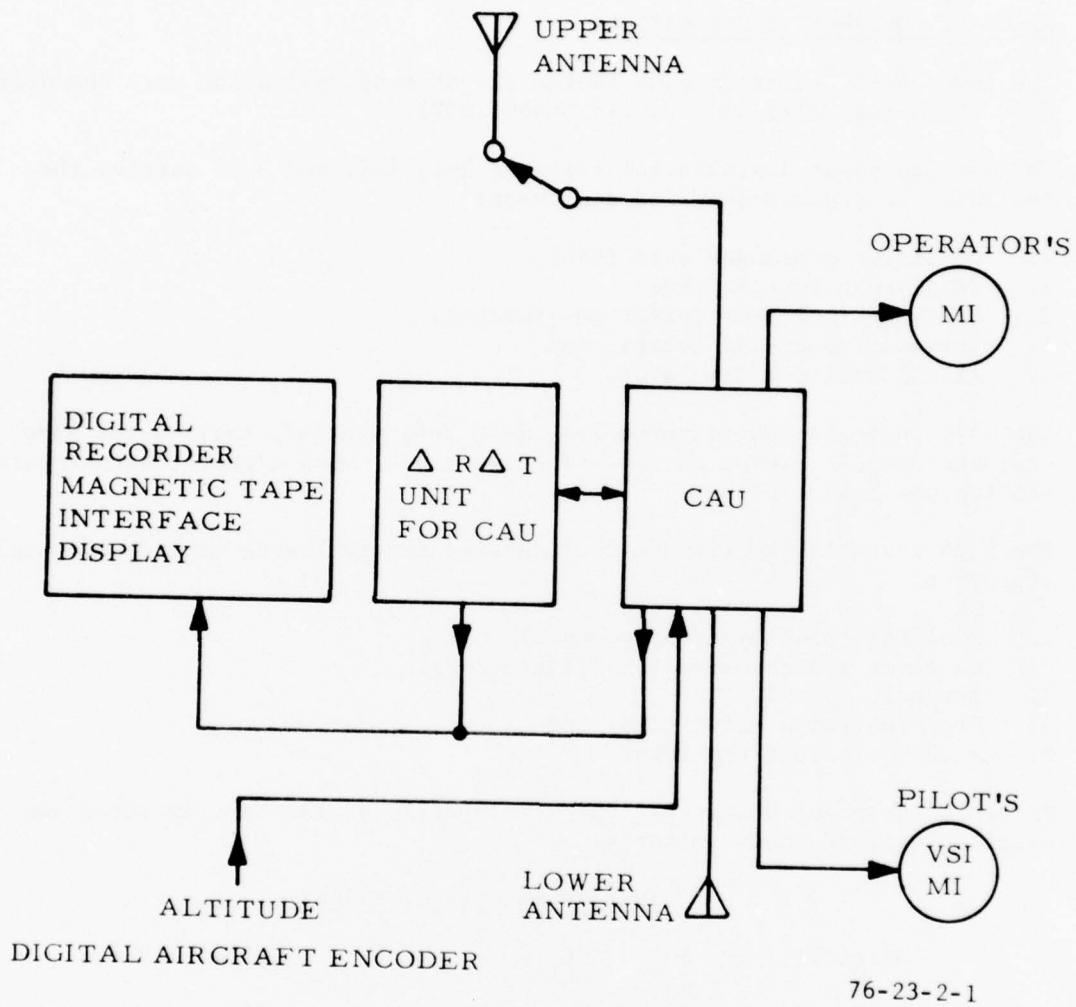

FIGURE 2-1. N42 CAU INSTALLATION WITH INSTRUMENTATION CONSISTING OF DIGITAL RECORDER/MAGNETIC TAPE INTERFACE AND DISPLAY

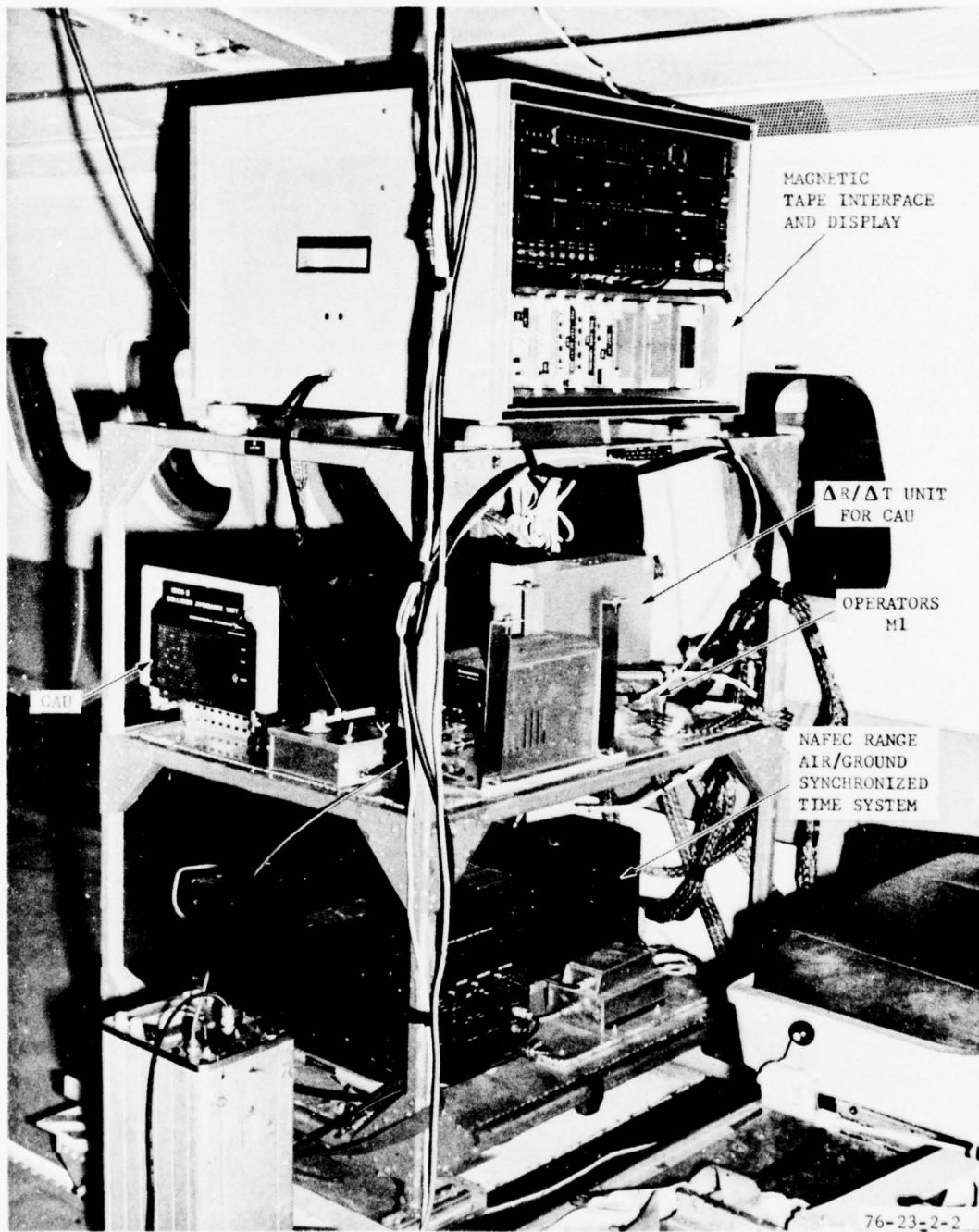
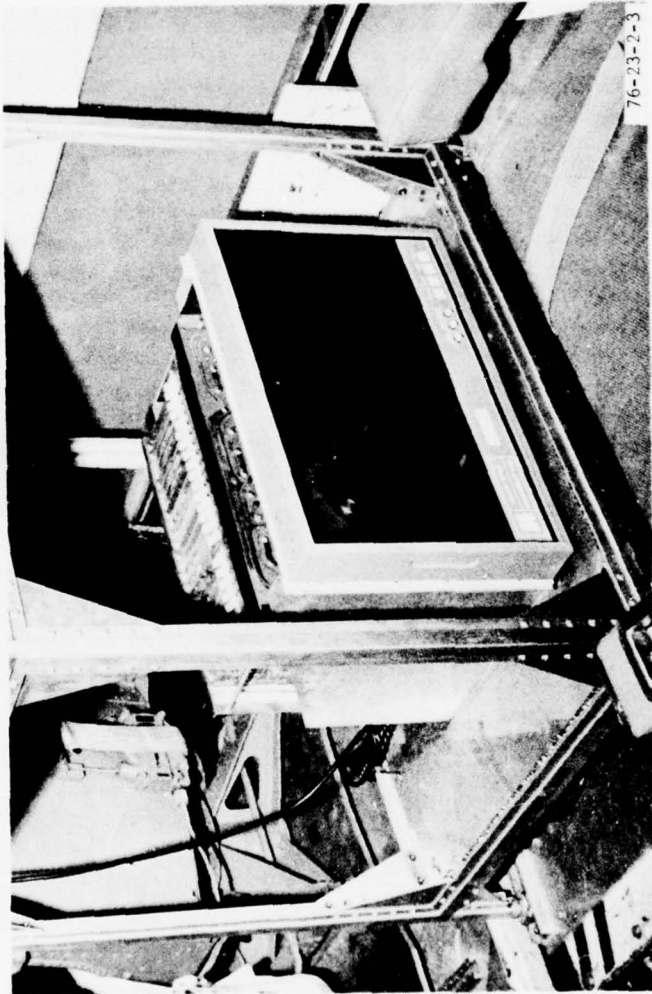
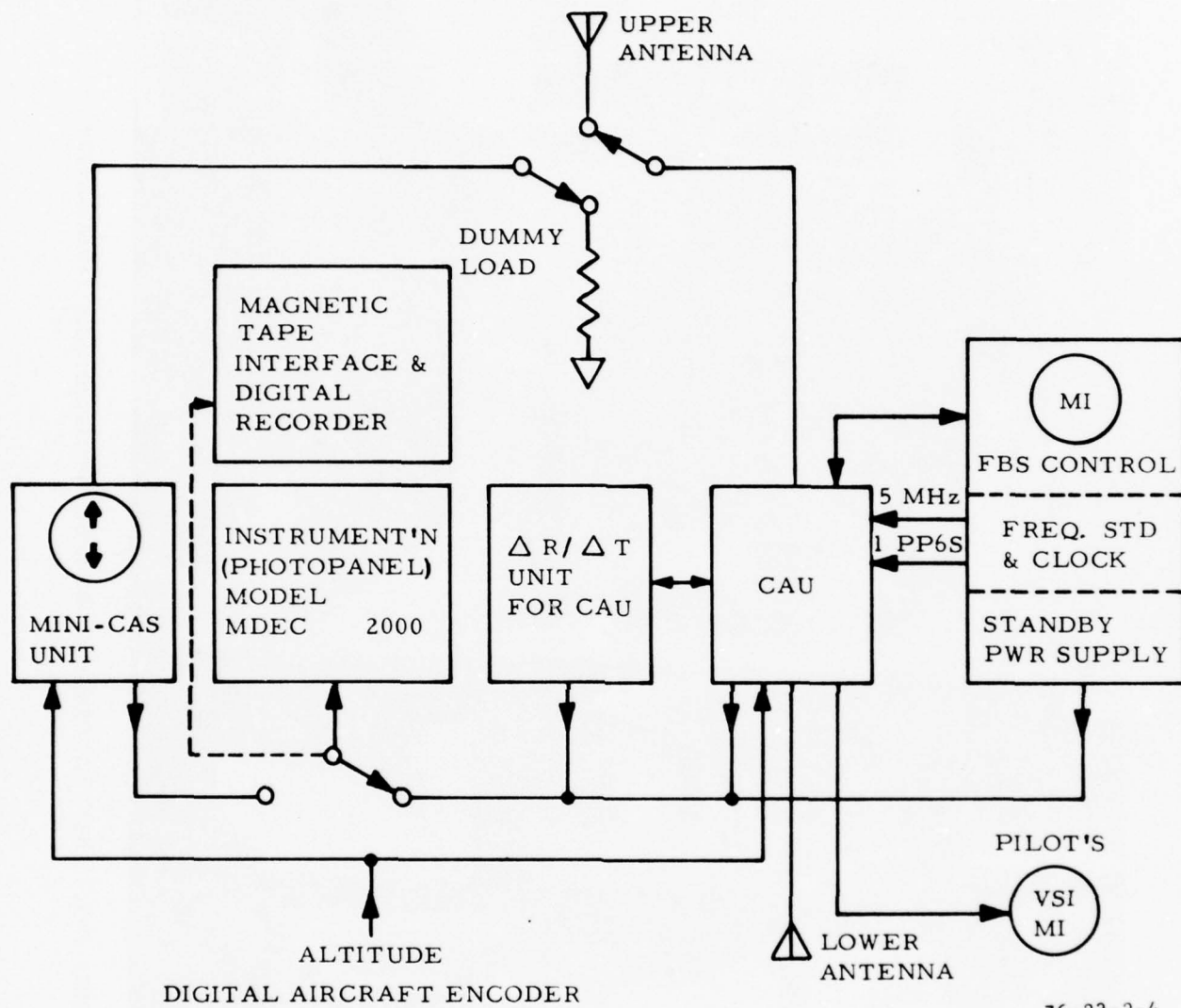

FIGURE 2-2. N42 CAU/MAGNETIC TAPE INTERFACE AND DISPLAY INSTALLATION



76-23-2-3

FIGURE 2-3. N42 DIGITAL RECORDER INSTALLATION



76-23-2-4

FIGURE 2-4. N377 CAU/Mini-CAS INSTALLATION WITH INSTRUMENTATION CONSISTING OF DIGITAL RECORDER/MAGNETIC TAPE INTERFACE AND PHOTOPANEL DISPLAY

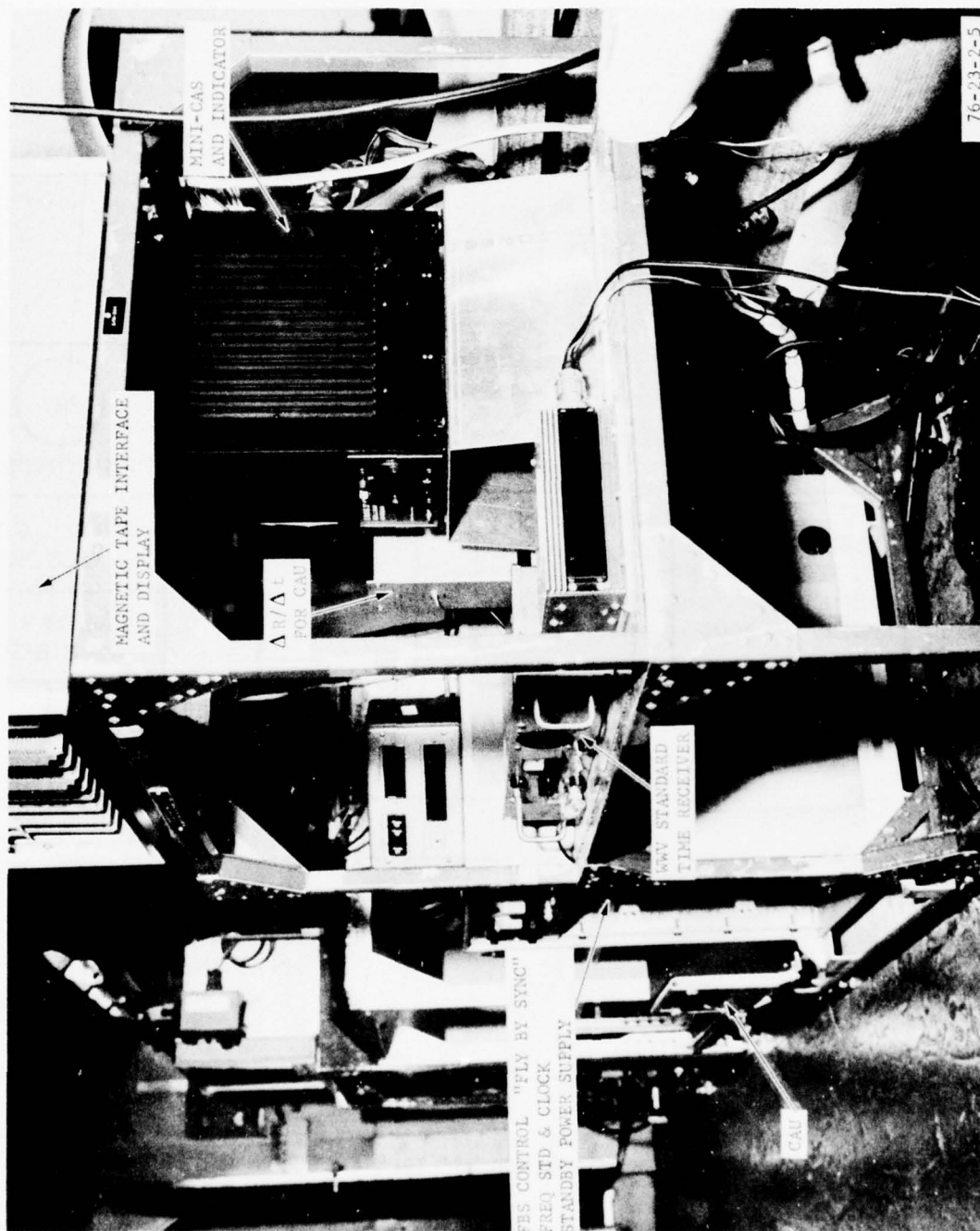

FIGURE 2-5. N377 CAU/MINI-CAS WITH SYNCHRONIZED TIME INSTALLATION

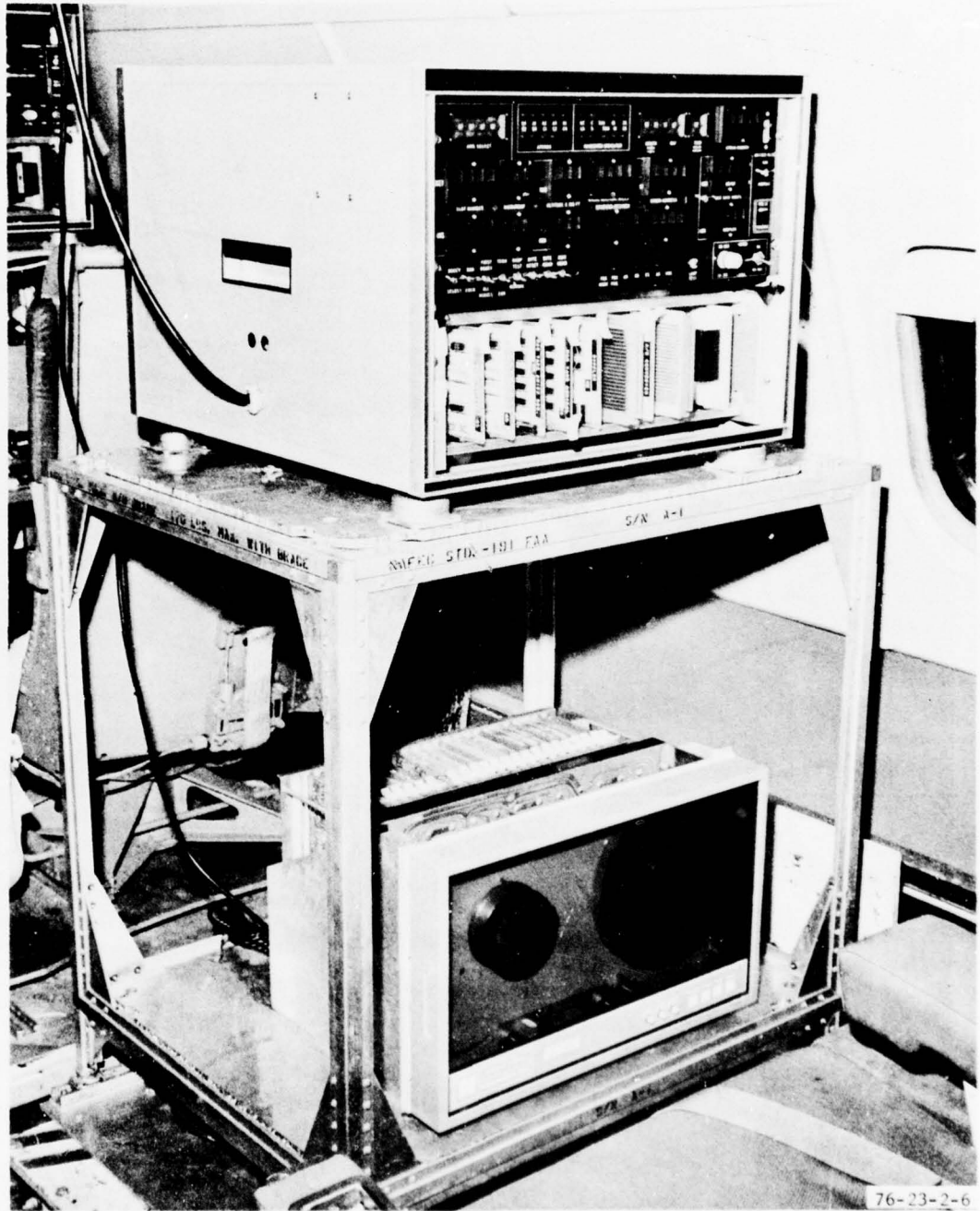

FIGURE 2-6. N377 MAGNETIC TAPE INTERFACE AND DISPLAY WITH DIGITAL RECORDER

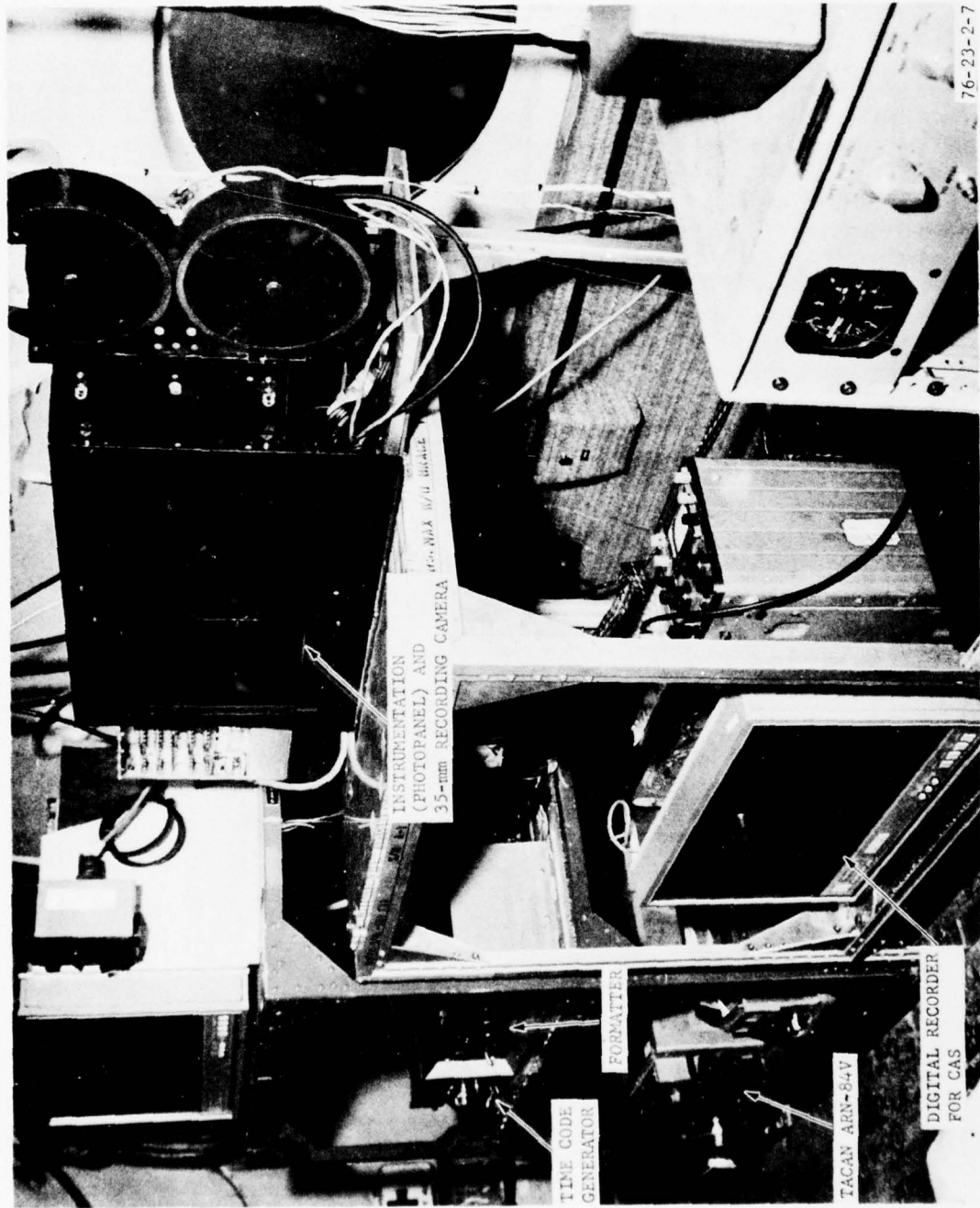
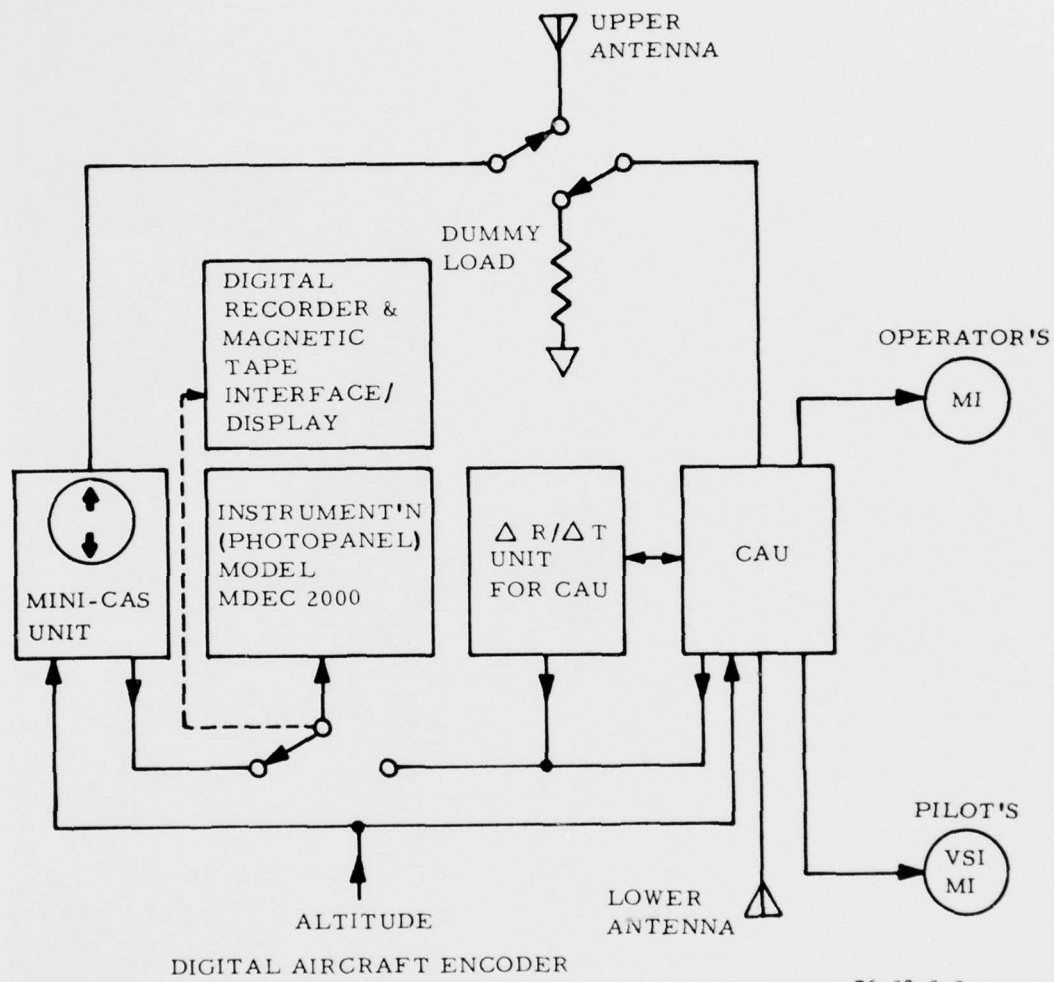

FIGURE 2-7. N377 CAS PHOTOPANEL INSTRUMENTATION DISPLAY AND TACAN AIR-AIR RANGE MEASUREMENT EQUIPMENT



76-23-2-8

FIGURE 2-8. N376 CAU/MINI-CAS INSTALLATION WITH INSTRUMENTATION CONSISTING OF DIGITAL RECORDER/MAGNETIC TAPE INTERFACE AND PHOTOPANEL DISPLAY

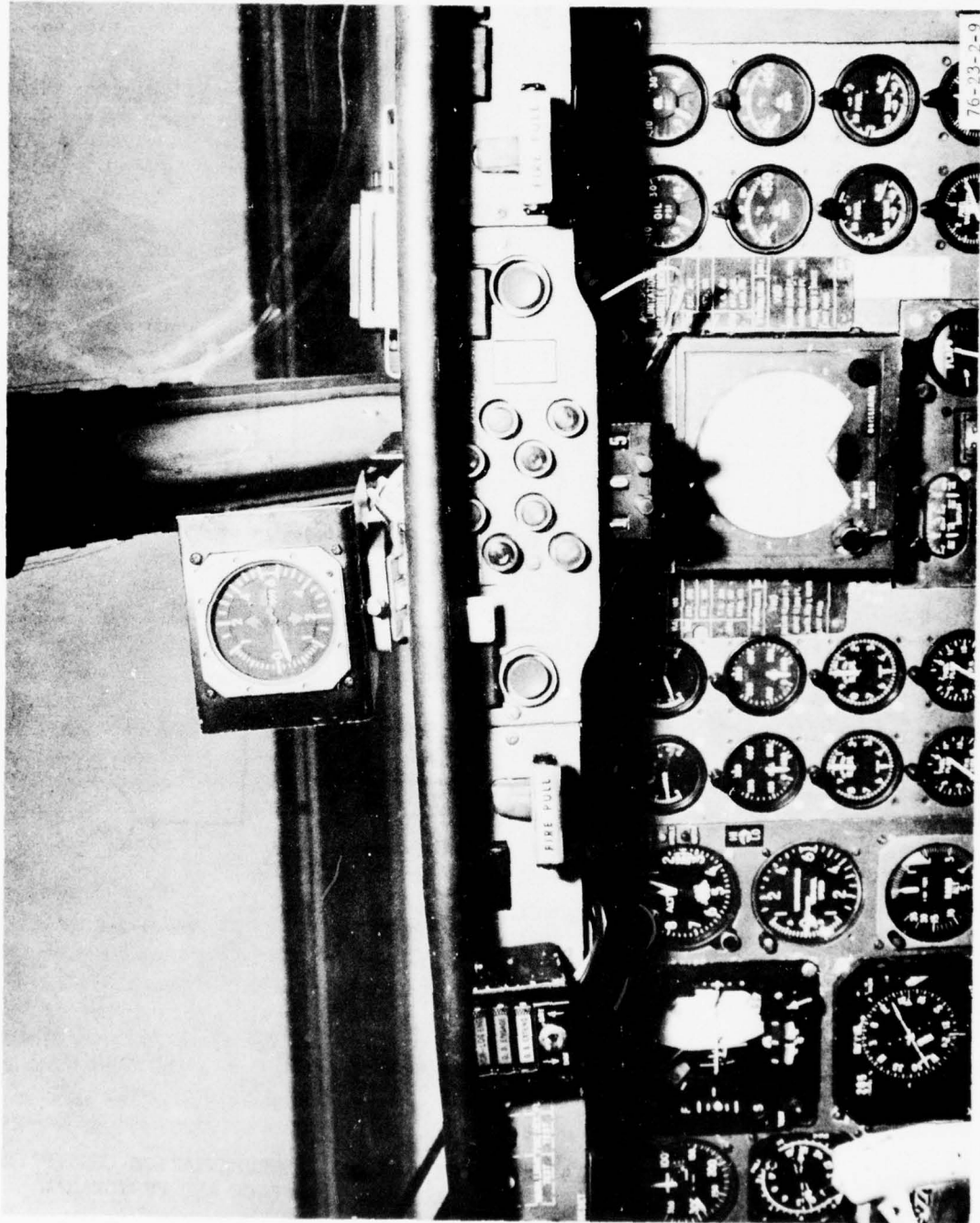

FIGURE 2-9. G159 GULFSTREAM PILOT MANEUVER INDICATOR INSTALLATION

Throughout the total test program, N376 (A/C 2) was the photoinstrumentation collection aircraft, and all data were provided by 35-millimeter (mm) camera pulse-actuated from the CAS hardware. The data collection was accomplished in the following manner:

PHASE I. Flights 1 through 26 were two-aircraft flights, and collection was by photoinstrumentation using the pulse-actuated camera.

PHASE II. Flights 27 through 39 were a mix of two- and three-aircraft flights, and data collection was by photoinstrumentation and magnetic tape interface with a digital recorder on the third aircraft.

PHASE III. Flights 40 through 65 were all magnetic tape interface, except when a third aircraft was involved using photoinstrumentation.

The antenna locations and station lengths are listed in table 2-1. The lengths are broken down by equipment used aboard each aircraft. Selected aircraft locations for the CAS and Tactical Air Navigation (TACAN) antennas are shown in figures 2-10, 2-11, and 2-12.

#### FLIGHT TEST INSTRUMENTATION.

NAFEC provided and operated the following instrumentation on board the aircraft:

1. CAS magnetic tape interface and instrumentation display;
2. Kennedy Model 1708 digital tape recorder;
3. Data recording 35-mm camera used on the photoinstrumentation panel;
4. AN/ARN-84V airborne TACAN set and formatter/digital tape recorder (Kennedy Model 1708);
5. NAFEC Range Air-Ground Synchronized Timing ultrahigh frequency (UHF) transmissions;
6. Onboard precision clock system consisting of a Datametrics model SP-305-SE time code generator, Kinematics model time frequency standard receiver Mark IV receiver, and a Model 1710 HP Hewlett-Packard oscilloscope;
7. ATCRBS digital barometric altitude encoder.

CAS MAGNETIC TAPE INTERFACE AND INSTRUMENTATION DISPLAY. The CAS magnetic tape interface and instrumentation display (figure 2-13) was designed and built at NAFEC. Its function was to display information from MDEC CAS equipment during flight tests, by recording all target and own-plane information.

The instrumentation and interface input are received from the following:

1. Time code generator,
2. Select switches on the interface,
3. CAU or Mini-CAS, and
4. ATCRBS decoder.

TABLE 2-1. ANTENNA LOCATIONS

<u>Aircraft</u>	<u>Equipment</u>	<u>Lower Antenna</u>		<u>Upper Antenna</u>	
		<u>Station (Inches)</u>	<u>Lead-in Length (ft)</u>	<u>Station (Inches)</u>	<u>Lead-in Length (ft)</u>
N377	CAU	251	52	313	28.5
N376	CAU	251	31	313	28.5
N42	CAU	706	52	667	52
N377	Mini-CAS			313	12.5
N376	Mini-CAS			313	15.5

NOTE: Upper antenna on N377 and N376 had a 3.5-foot pigtail from antenna station. CAU equipment had a permanent 25-foot fixed RG/8U cable on mounting rack.

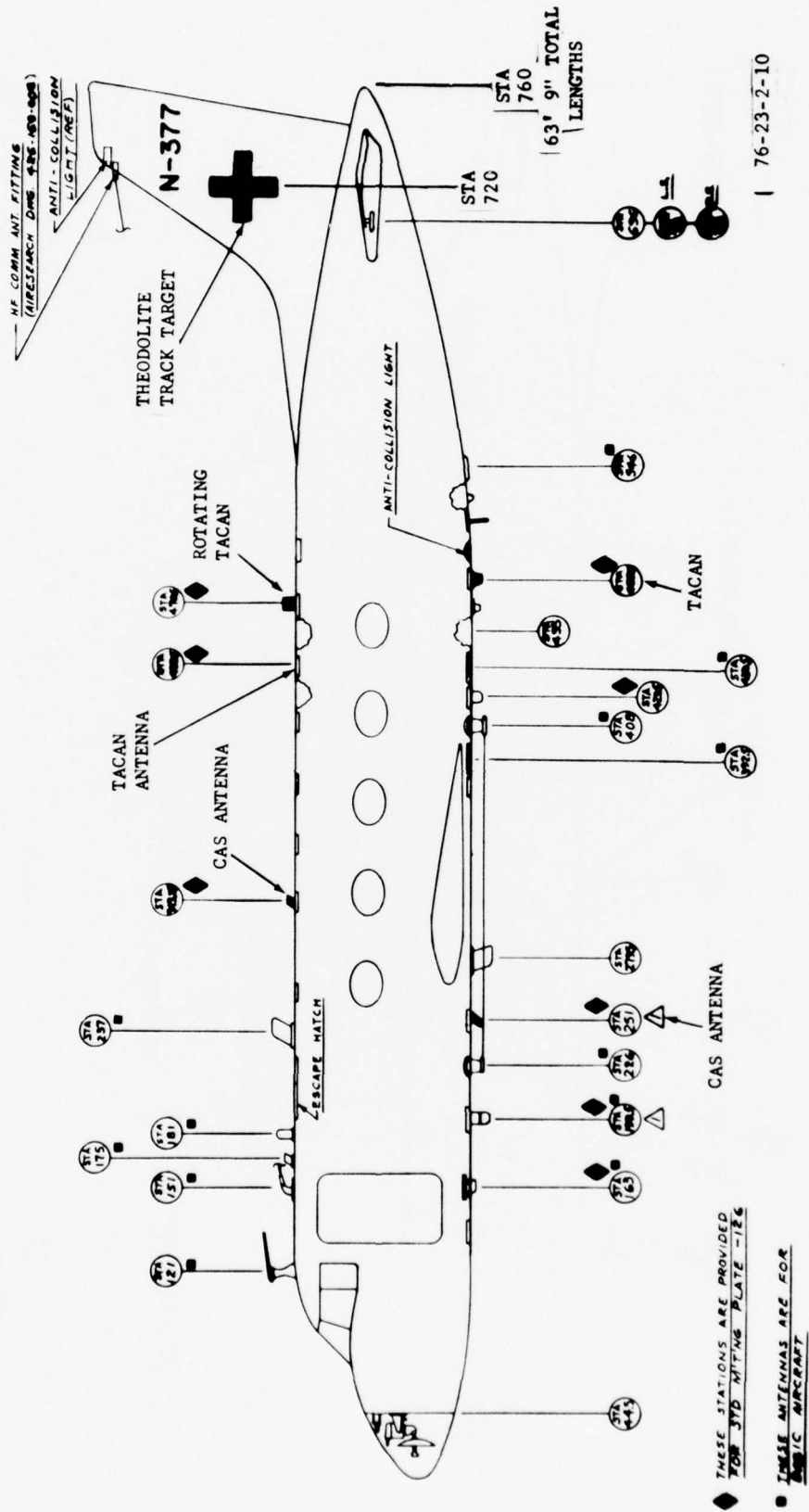
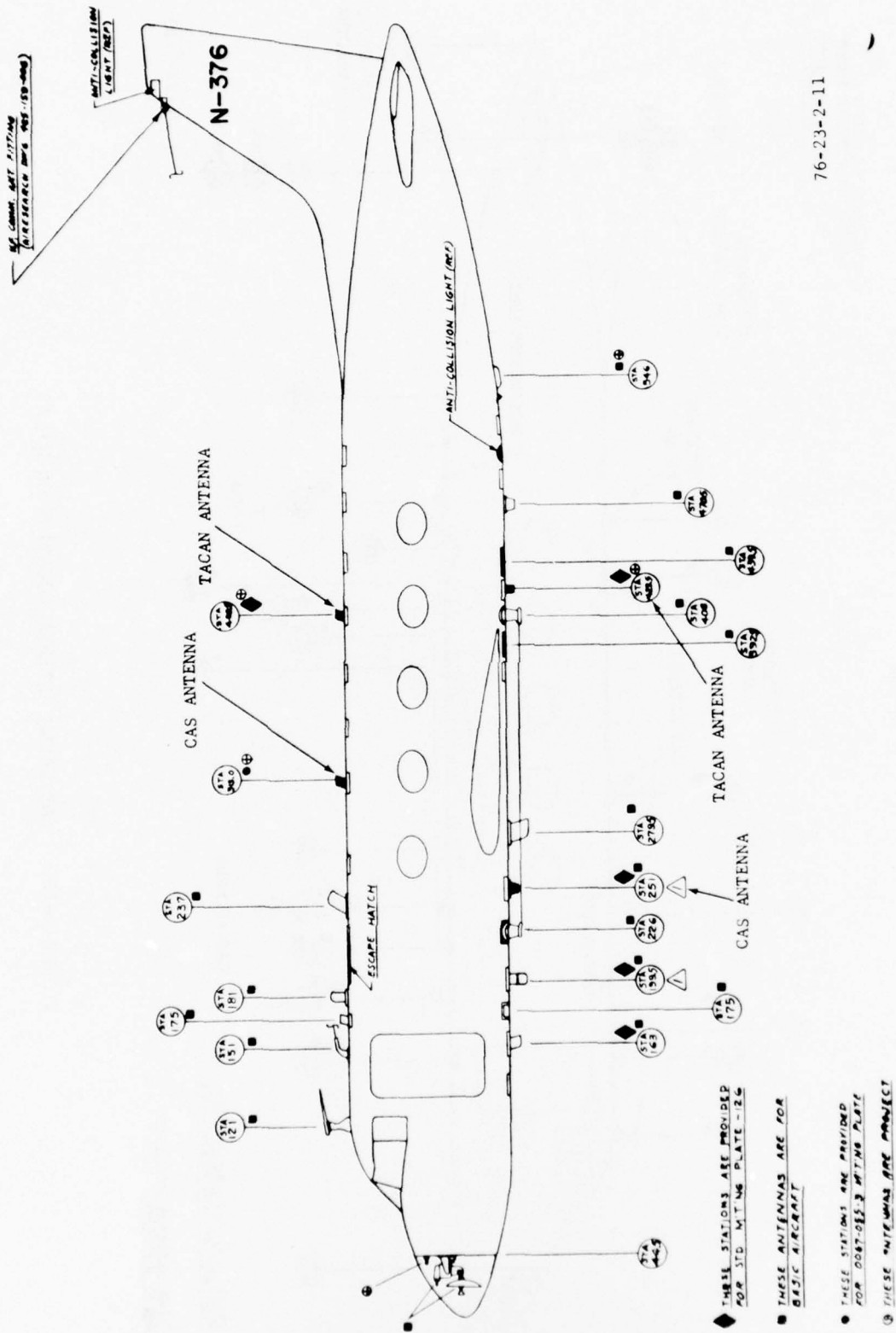

FIGURE 2-10. CAS/TACAN ANTENNA LOCATION ON N377



76-23-2-11

FIGURE 2-11. CAS/TACAN ANTENNA LOCATION ON N376



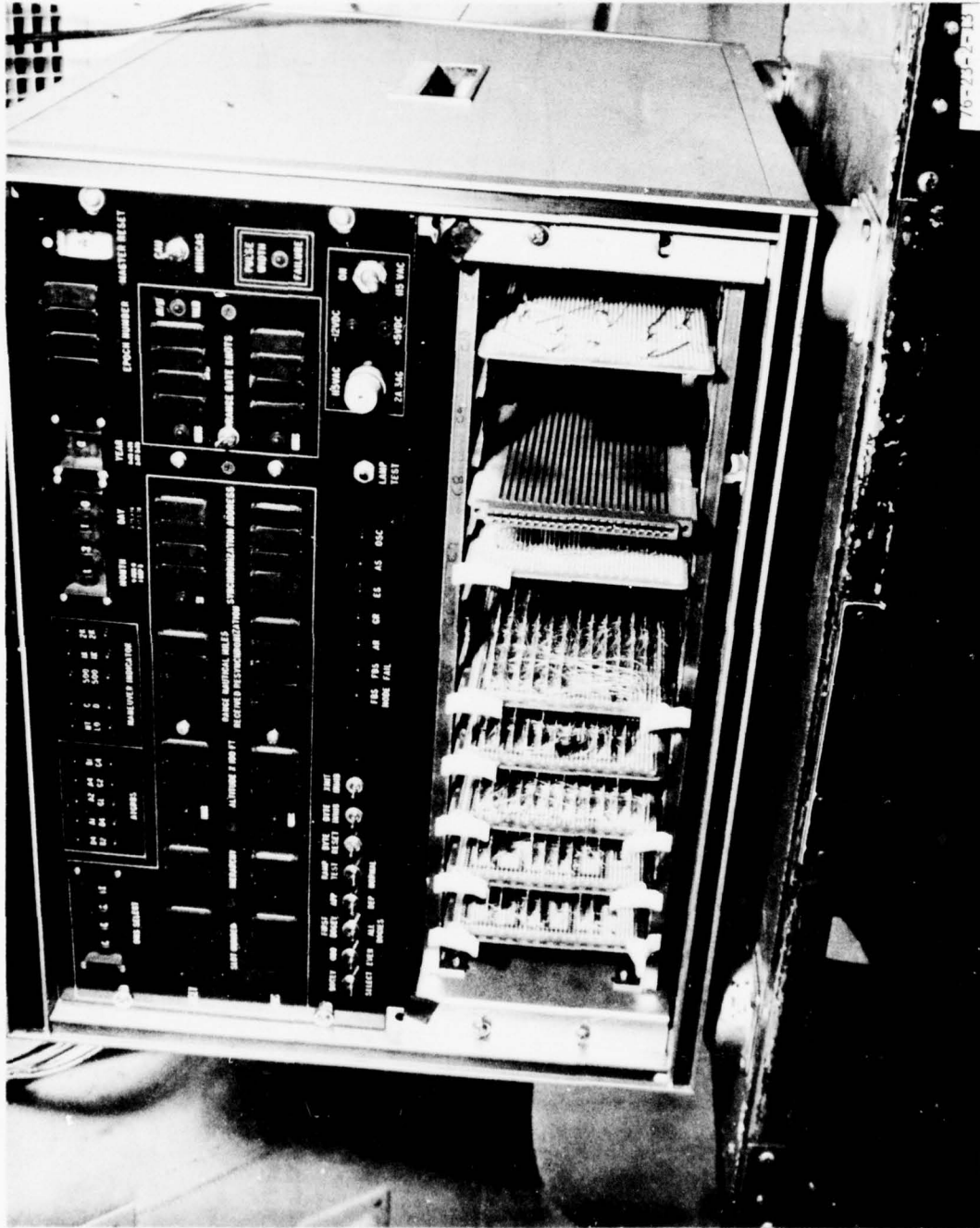

FIGURE 2-13. CAS MAGNETIC TAPE INTERFACE AND INSTRUMENTATION DISPLAY

As shown in block diagram (figure 2-14), the CAS magnetic tape interface and display inputs synchronized time from a time code generator, to record time in each aircraft to one tenth of a second. A CAU/Mini-CAS switch is used to set individual presets, which allows for different signal verification times in the CAU or Mini-CAS. Data from these units are grouped into 3-second time intervals called epochs. Each epoch is divided into 2,000 time slots on CAS message slots. The information associated with each target aircraft is assigned a particular slot. As the information range, altitude, hierarchy, and resync are received, they are encoded in time relative to that message slot. The CAS data are then processed into meaningful parameters for display and magnetic tape recording.

A control sequencer is used to transfer data from input storage to the 1024 byte shift register, which is used to serialize the data bytes for magnetic recording. Due to timing considerations, it was necessary to multiplex the data. The tape interface and control does the transferring of data to the Kennedy recorder. Inputs to the recorder are six-bit characters. An odd parity is generated internally in the magnetic tape unit and recorded on the seventh tape track. Data are stored in variable-length records, with the recorder inserting gaps between the records. Each record contains the information in one epoch of all data received by a CAU or Mini-CAS. Data are then recorded for slot 0, own message slot (OMS), own message slot plus 4 (OMS+4), and all slots containing intruders in addition to an end of epoch. The test slots are also recorded within the epoch.

A record length is determined by the number of intruders that occur in a particular epoch. The recording format for the data is shown in table 2-2, along with the Field content list shown in table 2-3 and Field content definitions shown in table 2-4.

On the display, light emitting diode (LED) readouts are controlled by the display control and are updated every 3 seconds. When the SELECT MODE switch is engaged, a data slot is determined by the dialed-in data message slot (DMS) number which is displayed along with the OMS information. If the switch is in bogey mode, the display will sequence through all intruder slots, one epoch at a time. A detailed description of the display instrumentation and magnetic tape interface will be found in reference 5.

DATA RECORDING CAMERA. The 35-mm data recording camera was used in the collection of CAS information from the instrumentation photopanel shown in figures 2-15 and 2-16.

Information displayed every epoch (3 seconds) was recorded. The camera was activated by a pulse derived from the CAS instrumentation. This pulse was transmitted after all CAS information was frozen on the display, usually at the end of each epoch (slot 1940). Precautions were taken to avoid any slot number greater than 1940, which would have offset the data into the next epoch. After each flight the film was developed and reviewed for equipment failures or operational deficiencies. A print was then made and released to data preparation for reduction. The information was read, and the data were transferred to punch cards. For each aircraft, the cards were assembled by flight, run, and transferred on tape in binary coded decimal (BCD) form. A typical sample printout can be seen in Chapter 6, and a program description can be found in reference 6.

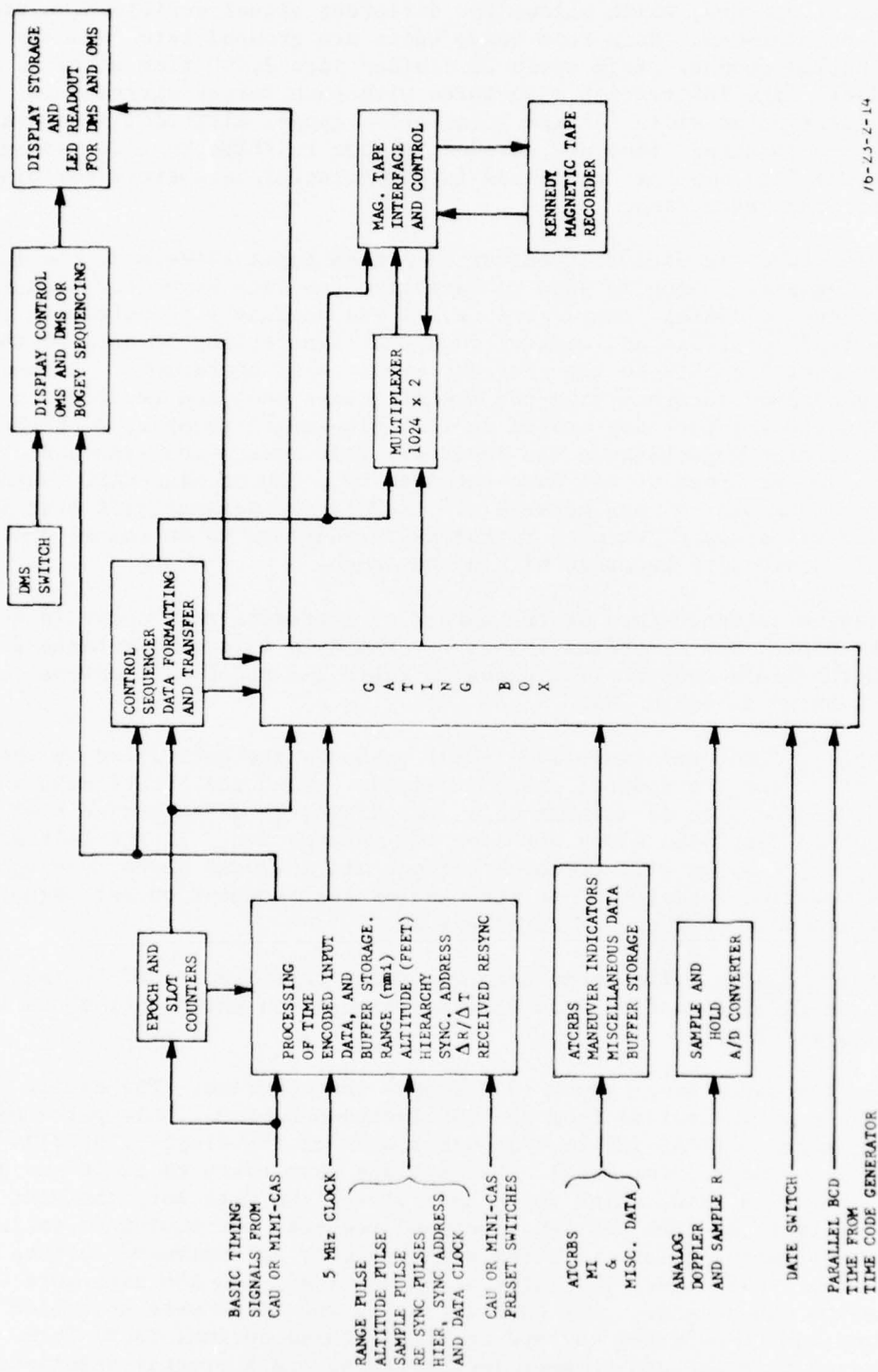

76-23-2-14

FIGURE 2-14. BLOCK DIAGRAM OF CAS MAGNETIC TAPE INTERFACE AND INSTRUMENTATION DISPLAY

TABLE 2-2a. MAGNETIC TAPE DATA FORMAT

Identifier Bytes

Consists of 9 bytes. The first 3 bytes are all 1's. The last 3 bytes are all 1's. The 4th byte will identify the data that follow as shown below:

Bit 6	Bit 5	Bit 4	Bit 3	Bit 2	Bit 1
1	0	0	0	0	0 - - Start of Epoch
0	1	0	0	0	0 - - Data Message Slot
0	0	1	0	0	0 - - Own Message Slot
0	0	0	1	0	0 - - Unselected Intruder Slot
0	0	0	0	1	0 - - OMS+4 Slot
0	0	0	0	0	1 - - MI Data

Each record of data will contain one epoch. The record will begin with an Epoch Identifier which will be followed by 9 bytes of data. During the test of the record each classification of data will be preceded by its own identifier. The number of bytes in each classification are listed below:

- Data Message Slot - 18 bytes (one or none slots/epoch)
- Unselected Intruder Slot - 18 bytes (any number slots/epoch)
- Own Message Slot - 15 bytes (one slot/epoch)
- OMS+4 Slot - 4 bytes (one slot/epoch)
- MI Data - 2 bytes (once at end of epoch)

Byte Definitions for each Classification

For each byte shown the most significant bit will be at the left. The most significant byte of data for each type of data listed will be the left-most byte. Data will be stored on tape most significant byte first. As represented below, data will be stored left to right, then top to bottom in the sequence shown.

Much of the data will be represented by 4 bit binary coded decimal digits. The four bits will be weighted 8421 from left to right.

- 0 - - - - 0000
- 1 - - - - 0001
- 2 - - - - 0010
- 3 - - - - 0011
- 4 - - - - 0100
- 5 - - - - 0101
- 6 - - - - 0110
- 7 - - - - 0111
- 8 - - - - 1000
- 9 - - - - 1001

TABLE 2-2b. MAGNETIC TAPE DATA FORMAT

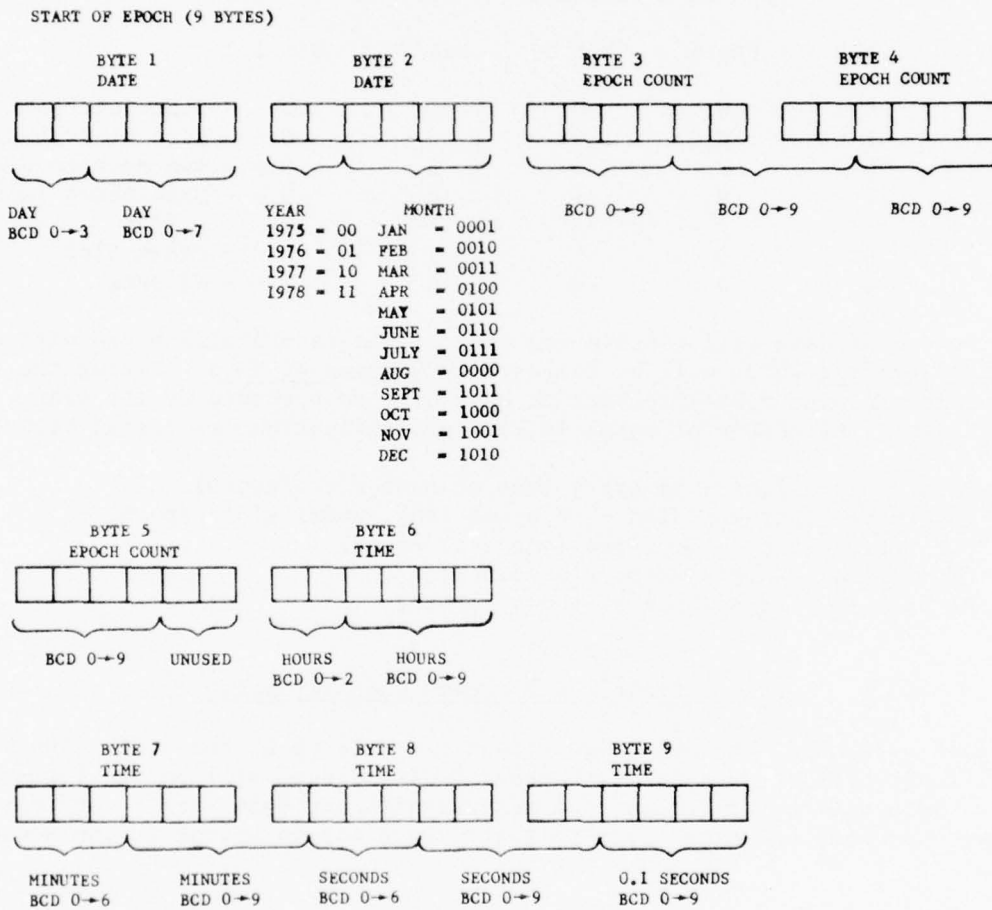

UNSELECTED INTRUDER SLOT (18 BYTES)

FORMAT OF DATA IS IDENTICAL TO  
THAT OF DATA MESSAGE SLOT  
SHOWN ON NEXT PAGE.

TABLE 2-2c. MAGNETIC TAPE DATA FORMAT

DATA MESSAGE SLOT (18 BYTES)

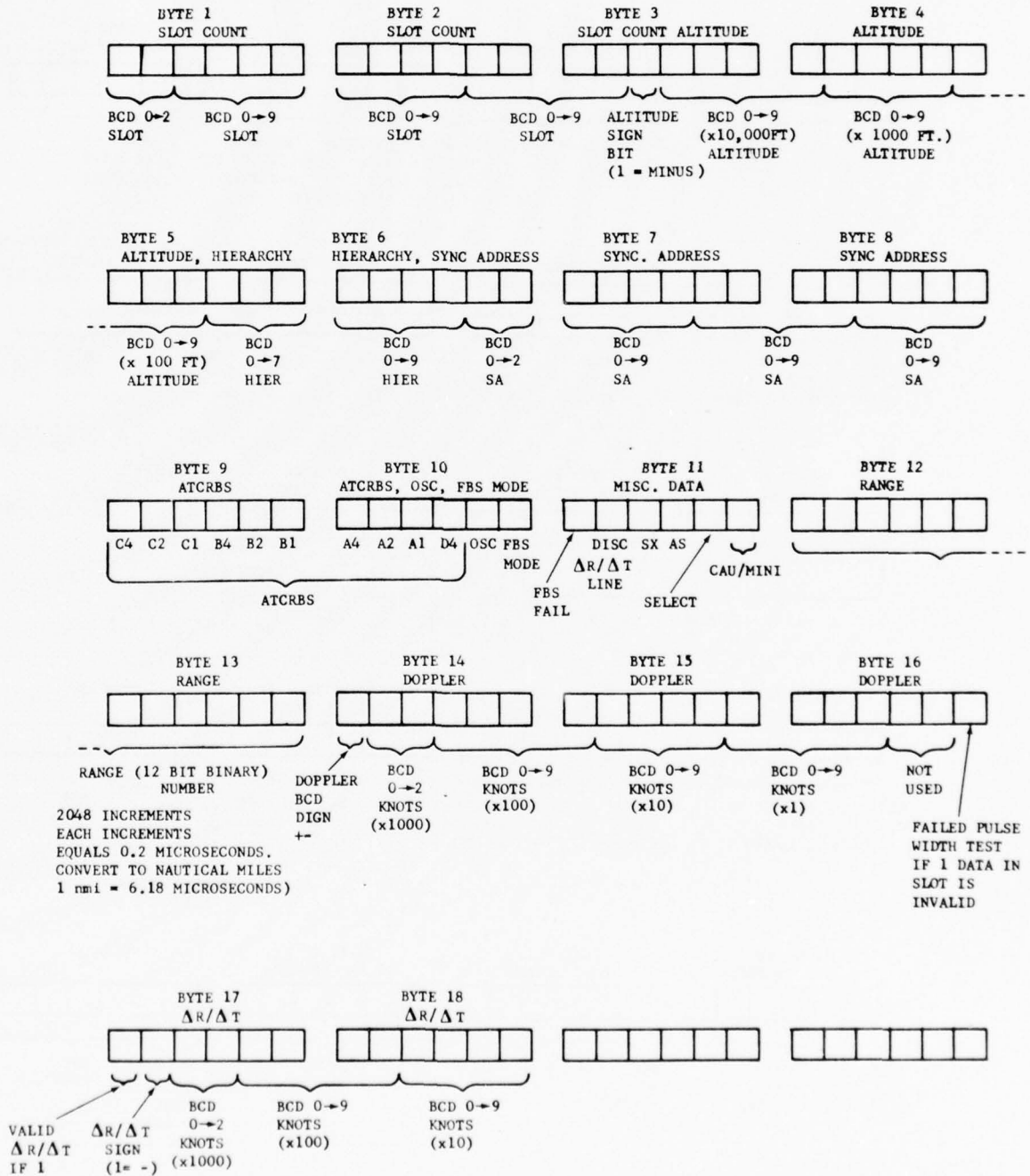

TABLE 2-2d. MAGNETIC TAPE DATA FORMAT

OWN MESSAGE SLOT (15 BYTES)

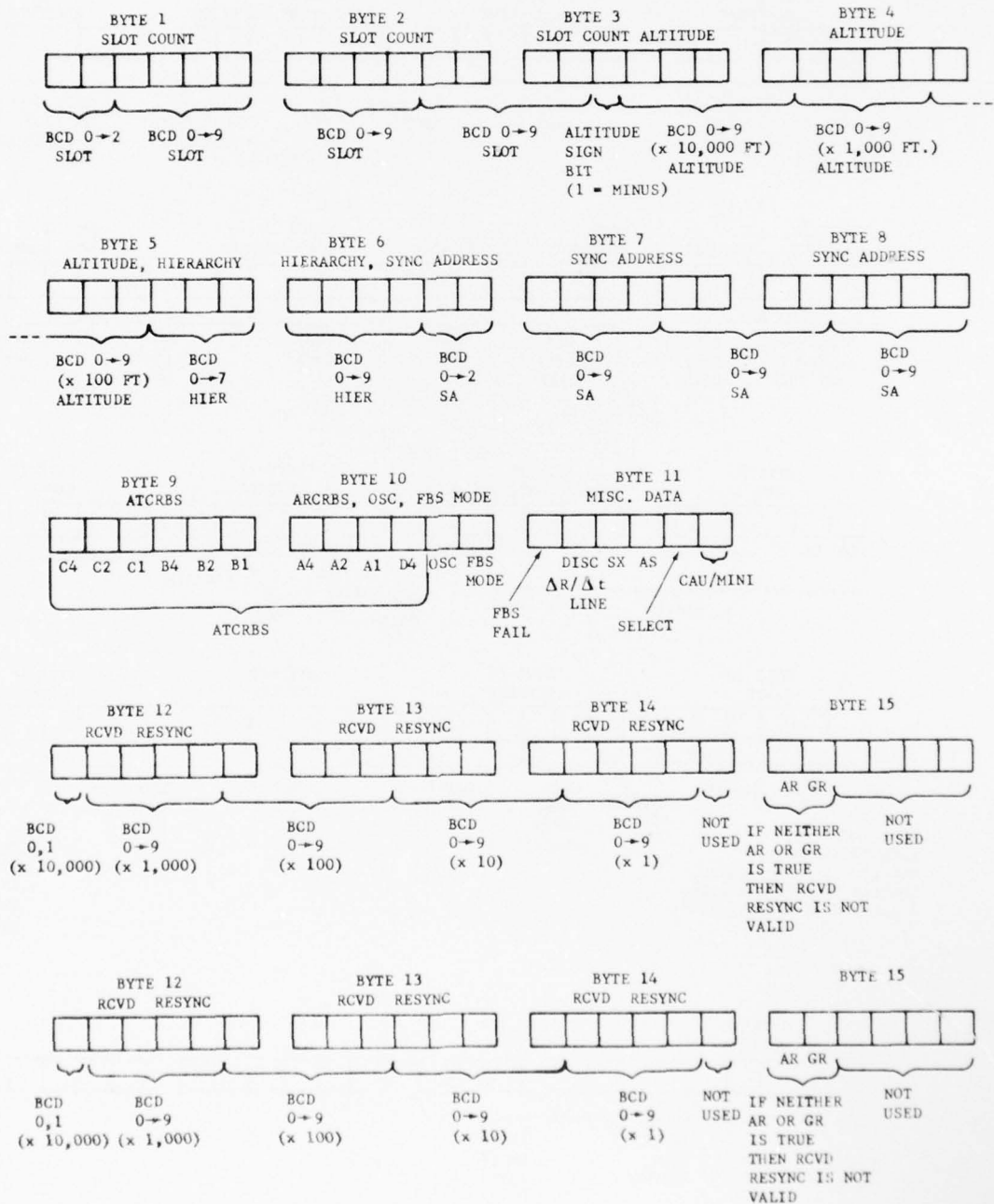
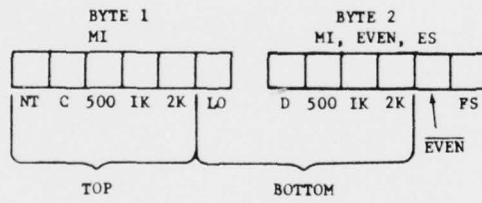

TABLE 2-2e. MAGNETIC TAPE DATA FORMAT

MI DATA (2 BYTES)  
(MANEUVER INDICATOR)



# BEST AVAILABLE COPY

TABLE 2-3. FIELD CONTENT LIST

Field	<u>1</u>	<u>2</u>	<u>3</u>	<u>4</u>	<u>5</u>	<u>6</u>	<u>7</u>	<u>8</u>	<u>9</u>	<u>10</u>
Start of Epoch	ID=1 Raw=32	Day (1 to 12)	Year (1975-1978)	Month (1 to 12) (Decoded)	Epoch (0 to 9999)	HR (0 to 24)	MIN (0 to 60)	SecX10 (0 to 600)		
Data MSG Slot	ID=2 Raw=16	Slot (0 to 2999)	AltX100 Ft (0 to +999)	HIER (0 to 63)	SYNC ADDR (0 to 2999)	C4 (0 to 1)	C2 (0 to 1)	C1 (0 to 1)	B4 (0 to 1)	B2 (0 to 1)
Own MSG Slot	ID=3 Raw=8	Slot (0 to 2999)	AltX100 Ft (0 to +999)	HIER (0 to 63)	SYNC ADDR (0 to 2999)	C4 (0 to 1)	C2 (0 to 1)	C1 (0 to 1)	B4 (0 to 1)	B2 (0 to 1)
Unselected Intruder	ID=4 Raw=4	Slot (0 to 2999)	AltX100 Ft (0 to +999)	HIER (0 to 63)	SYNC ADDR (0 to 2999)	C4 (0 to 1)	C2 (0 to 1)	C1 (0 to 1)	B4 (0 to 1)	B2 (0 to 1)
OMS+4 Slot	ID=5 Raw=2	RCD RSYNC (0 to 19999)		GR (0 to 1)						
Above Advisory										
MI Data	ID=6 Raw=1	NT (0 to 1)	C (0 to 1)	500 (0 to 1)	1k (0 to 1)	2K (0 to 1)	1D (0 to 1)	D (0 to 1)	500 (0 to 1)	1k (0 to 1)
Field	<u>11</u>	<u>12</u>	<u>13</u>	<u>14</u>	<u>15</u>	<u>16</u>	<u>17</u>	<u>18</u>	<u>19</u>	<u>20</u>
Start of Epoch										
Data MSG Slot	B1 (0 to 1)	A4 (0 to 1)	A2 (0 to 1)	A1 (0 to 1)	D4 (0 to 1)	OSC (0 to 1)	FBS Mode (0 to 1)	FBS Fail (0 to 1)	DISC DR/DT (0 to 1)	SX (0 to 1)
Own MSG Slot	B1 (0 to 1)	A4 (0 to 1)	A2 (0 to 1)	A1 (0 to 1)	D4 (0 to 1)	OSC (0 to 1)	FBS Mode (0 to 1)	FBS Fail (0 to 1)	DISC DR/DT (0 to 1)	SX (0 to 1)
Unselected Intruder	B1 (0 to 1)	A4 (0 to 1)	A2 (0 to 1)	A1 (0 to 1)	D4 (0 to 1)	OSC (0 to 1)	FBS Mode (0 to 1)	FBS Fail (0 to 1)	DISC DR/DT (0 to 1)	SX (0 to 1)
OMS+4 Slot										
MI Data	2K (0 to 1)	Even (0 to 1)	ES (0 to 1)							
Field	<u>21</u>	<u>22</u>	<u>23</u>	<u>24</u>	<u>25</u>	<u>26</u>	<u>27</u>	<u>28</u>	<u>29</u>	
Start of Epoch										
Data MSG Slot	AS (0 to 1)	SELECT (0 to 1)	CAU MINI (0 to 1)	Range (Outputted to nearest .001 NMI)	Doppler Sign (0 to 1)	Knots Doppler (0 to 2999)	Valid DR/DT (0 to 1)	DR/DT Sign (0 to 1)	Knots X10 DR/DT (0 to 299)	
Own MSG Slot	AS (0 to 1)	SELECT (0 to 1)	CAU MINI (0 to 1)	RCD RSYNC (0 to 19999)	AR (0 to 1)	GR (0 to 1)				
Unselected Intruder	AS (0 to 1)	SELECT (0 to 1)	CAU MINI (0 to 1)	Range (Outputted to nearest .001 NMI)	Doppler Sign (0 to 1)	Knots Doppler (0 to 2999)	Valid DR/DT (0 to 1)	DR/DT Sign (0 to 1)	Knots X10 DR/DT (0 to 299)	
OMS+4 Slot										
MI Data										

Odd = Ground Epoch  
Even = AIR Epoch

TABLE 2-4a. DEFINITIONS FOR FIELD CONTENT LIST

FIELD ID=1: FLIGHT IDENTIFICATION.

DAY, YEAR, MONTH. Date the flight was flown.

EPOCH. A count which is resettable to zero and increments by one count every epoch (once every three seconds).

HR, MIN, SEC. The time of day synchronized between each aircraft and ground tracking facilities.

FIELD ID=2: DATA MESSAGE SLOT (DMS) INFORMATION.

SLOT. The data message slot (DMS) number of the selected CAS that is being recorded.

ALT X100. Indicate altitude transmitted by the DMS in hundreds of feet (includes bias).

HIER. DMS hierarchy, as decoded from the biphasic message received. Hierarchy status (00 indicates ground station, and 63 indicates CAU in BUM---back up mode). Mini-CAS will display 63 as decoded by a CAU.

SYNC ADDR. Sync address slot number being requested for resync by the DMS as decoded from the biphasic message received.

ATCRBS. Indicates altitude code input (bits C4, C2, C1, B4, B2, B1, A4, A2, A1, and D4) from aircraft digital altimeter.

OSC. Indicates CAU is operating on the internal oscillator (5 MHz) instead of external source.

FBS. Indicates CAU is operating in FBS (fly-by-sync) mode. (Not used during evaluation).

FBS FAIR. Indicates a time-base disagreement between CAU and "Flying Clock" in FBS mode. Not used during evaluation.

DISC dR/dT. Status bit indicates (CAU only) whether the THREAT LOGIC is using Doppler or dR/dT successive rate input to compute a threat.

SX. Indicates resync triad was transmitted to the data slot aircraft by the onboard CAU.

AS. Antenna switch; even indicates air epoch (UPPER ANTENNA), and odd is ground epoch (LOWER ANTENNA).

TABLE 2-4b. DEFINITIONS FOR FIELD CONTENT LIST

SELECT BOGEY. In select position, the data message slot dialed in is recorded for one epoch. In bogey, a slot number for one epoch of any occupied slot in a roll call manner is recorded.

CAU MINI. Programs the range preset values for range zero correction for CAU or Mini-CAS.

RANGE. Slant range in nautical miles between (OMS) own aircraft and (DMS) data slot aircraft.

DOPPLER SIGN. Sign bit for Doppler range measurement, minus indicates aircraft are opening, plus indicates aircraft are closing.

KNOTS DOPPLER. Doppler range rate in knots between OMS aircraft and DMS aircraft.

VALID dR/dT. A sign bit of "1" indicator CAS verification of a valid successive range rate measurement.

dR/dT SIGN. Successive rate logic sign bit. Minus indicates aircraft are opening. Plus indicates aircraft are closing.

KNOTS X10 dR/dT. The relative velocity between OMS aircraft and DMS aircraft using successive rate measurement logic.

FIELD ID=3: OWN MESSAGE SLOT (OMS).

Data positions 1 through 23 same as DMS.

RCVD RSYNC. The time in microseconds, relative to start of own slot, when resync is received. Zero error is 1419.25.

AR. A "1" bit indicates the air resync triad was received.

GR. A "1" bit indicates the ground resync triad was received.

FIELD ID=4: UNSELECTED INTRUDER.

Data positions same as DMS. The ground station transmitted to all CAS participants test slots on the odd epochs. The magnetic tape interface brought out this capability and recorded these messages in the unselected intruder during odd epoch ground transmission. Table 2-4 shows the slot information messages that appeared during the transmission.

TABLE 2-4C. DEFINITIONS FOR FIELD CONTENT LIST

FIELD ID=5: OMS + 4 SLOT (OWN MESSAGE SLOT).

The CAU stops transmitting and listens for one epoch in its own message slot, on a random basis, for a coslot occupant. The interruption of the CAU transmission does not occur during successive epochs and only after all threats have been cleared during an encounter.

FIELD ID=6: MI DATA (MANEUVER INDICATOR).

Indicates the threat status displayed on own (OMS) aircraft vertical maneuver indicator. The following definitions apply:

- NT - No Turn
- C - Climb
- 500 - Limit Vertical Speed to 500 ft/min ascent climb
- 1K - Limit Vertical Speed to 1,000 ft/min ascent climb
- 2K - Limit Vertical Speed to 2,000 ft/min ascent climb
- LO - Level Off
- D - Dive
- 500 - Limit Vertical Speed to 500 ft/min descent
- 1K - Limit Vertical Speed to 1,000 ft/min descent
- 2K - Limit Vertical Speed to 2,000 ft/min descent

EVEN. Epoch start triad--odd for ground epoch and even for air epoch.

ES. Indicates epoch start triad, ground or air received and verified.

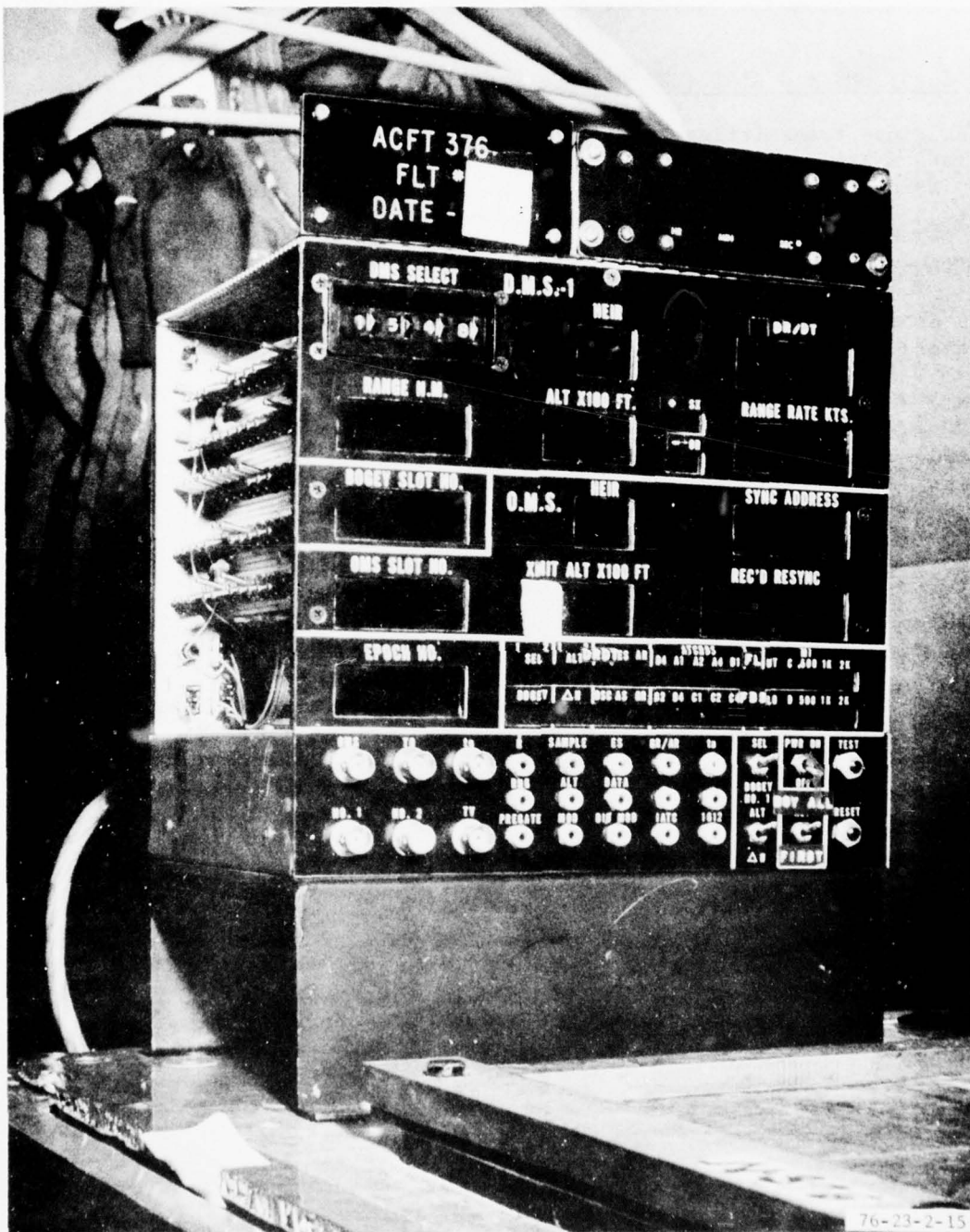

FIGURE 2-15. PHOTOPANEL INSTRUMENTATION AND DISPLAY MONITOR

DATA LOG

DATE: 3-15-75  
 FLIGHT: 5  
 ACFT: 376

REMOTE TIME DISPLAY

12 06 30.2

DMS SELECT

0 0 3 7

D.M.S. - I

HIER

01

$\Delta R / \Delta T$

1936

RANGE N.M.

0275

ALT X 100 FT

021

A SX

+

B OR

-

DOPPLER RANGE RATE KTS.

+0035

BOGEY SLOT NO.

0037

HIER

01

SYNC ADDRESS

1936

O.M.S.

O.M.S. SLOT NO.

0021

XMIT ALT X 100 FT

034

REC'D RESYNC

14191

EPOCH NO.

1298

1	2	1	2	RUN ES AR			ATCRBS				FBS FAIL		MI					
SEL		ALT					D4	A1	A2	A4	B1			NT	C	500	1K	2K
<input type="radio"/>	<input type="radio"/>	<input type="radio"/>	<input type="radio"/>	<input type="radio"/>	<input type="radio"/>	<input type="radio"/>	<input type="radio"/>	<input type="radio"/>	<input type="radio"/>	<input type="radio"/>	<input type="radio"/>	<input type="radio"/>	<input type="radio"/>	<input type="radio"/>	<input type="radio"/>	<input type="radio"/>	<input type="radio"/>	<input type="radio"/>
BOGEY		$\Delta$ H	OSC	AS	GR		B2	B4	C1	C2	C4	FBS MODE		LO	D	600	1K	2K
<input type="radio"/>	<input type="radio"/>	<input type="radio"/>	<input type="radio"/>	<input type="radio"/>	<input type="radio"/>	<input type="radio"/>	<input type="radio"/>	<input type="radio"/>	<input type="radio"/>	<input type="radio"/>	<input type="radio"/>	<input type="radio"/>	<input type="radio"/>	<input type="radio"/>	<input type="radio"/>	<input type="radio"/>	<input type="radio"/>	<input type="radio"/>

76-23-2-16

FIGURE 2-16. PHOTOPANEL INSTRUMENTATION AND DISPLAY

AIRBORNE TACAN MEASUREMENT SYSTEM. The airborne TACAN system model AN/ARN-84V (figures 2-17, 2-18, and 2-19) provided the air-to-air reference range separation measurement during the CAS evaluation. The instrumentation package aboard each aircraft included the AN/ARN-84V TACAN, magnetic tape recorder, time code generator (jointly used with CAS), remote numeric displays of slant range and signal processing interfacing with the TACAN and time generator signals. A typical sample of the TACAN quick-look printout can be seen in figure 2-20, and program description found in reference 7.

This allows each aircraft supply redundant range information on each flight. This output was used in the CAS analysis program for ranging data comparison.

The following special feature options were provided by the formatter:

- (1) Recording rates on range of 1, 2, 5, or 10 samples per second.
- (2) Software recognition flags from external events.

NAFEC RANGE AIR-GROUND TIMING. NAFEC Range Control distributes precise time by UHF transmission to all aircraft, and by land lines digitally to each tracking facility in the NAFEC range system. The correlation of all sensor data was compared against this time base. The onboard precision clock in each aircraft was initially synchronized by using the air-ground timing. At this time, the CAS instrumentation epoch counter was "zeroed" out. The instrumentation epoch count was then restarted in synchronization to within 1 millisecond (ms) of real time. The slot number (difference time between slots) was readjusted by computer programming during analysis. This allowed for a real-time analysis from each sensor.

ONBOARD PRECISION CLOCK SYSTEM. The precision clock was initially synchronized by the range control timing system during the preflight period. The onboard system was utilized for monitoring time throughout the test mission and, if required, to reset to WWV standard time. Each aircraft was equipped with a time frequency standard receiver (WWV), oscilloscope and precision time generator. The clock was synchronized by externally triggering the oscilloscope from the time generator and bringing the WWV tick pulse in coincidence with the time generator trigger. This time-check procedure was displayed at all times and checked periodically by the CAS observer.

ATCRBS DIGITAL BAROMETRIC ALTITUDE ENCODER. The altitude was provided to the CAU or Mini-CAS by a digital altitude signal encoded by the aircraft ATC transponder. The reference altitude was a standard barometric setting of 29.92 inches of Mercury (Hg).

#### FLIGHT CALIBRATION.

An in-flight calibration was performed prior to each test mission. Aircraft usually performed the calibration during the transit time to the test area. It consisted of aircraft joining up, and flying side by side (50 to 100 feet apart) and calibrating the airspeed through the band programmed for the day's flight emission. Upon completion, a series of altitude-level changes were

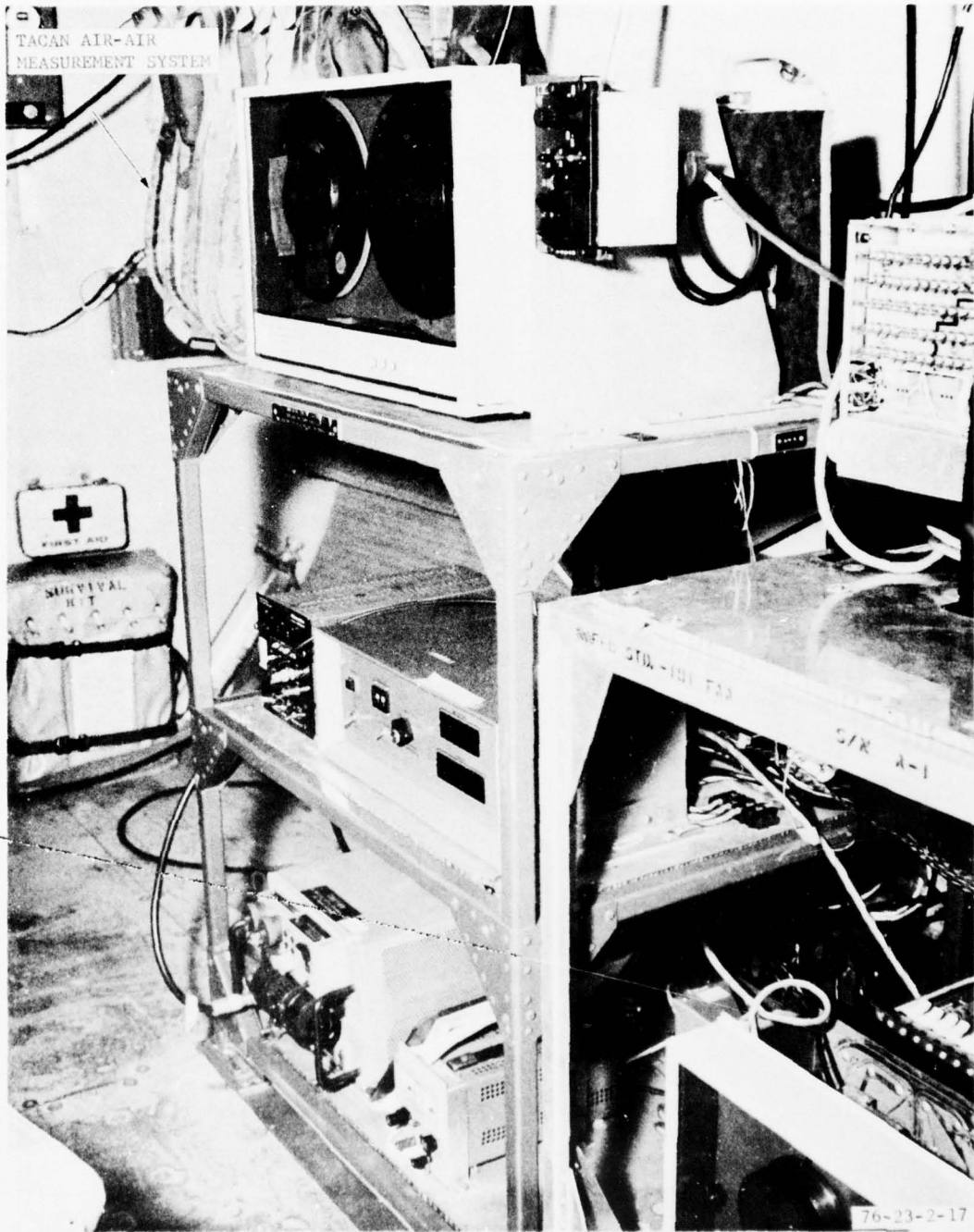

FIGURE 2-17. GULFSTREAM N377 TACAN AIR-AIR RANGE MEASUREMENT INSTALLATION

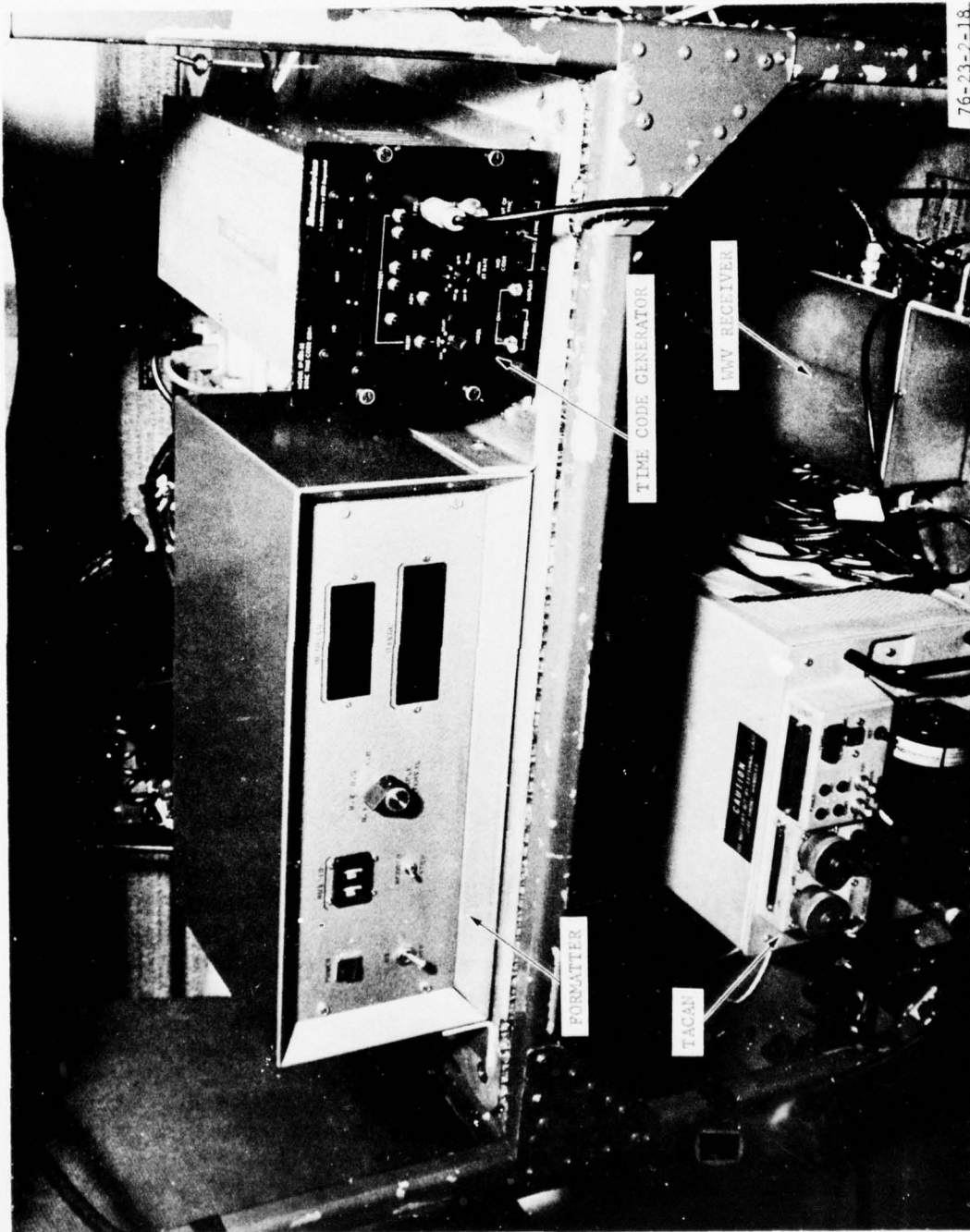
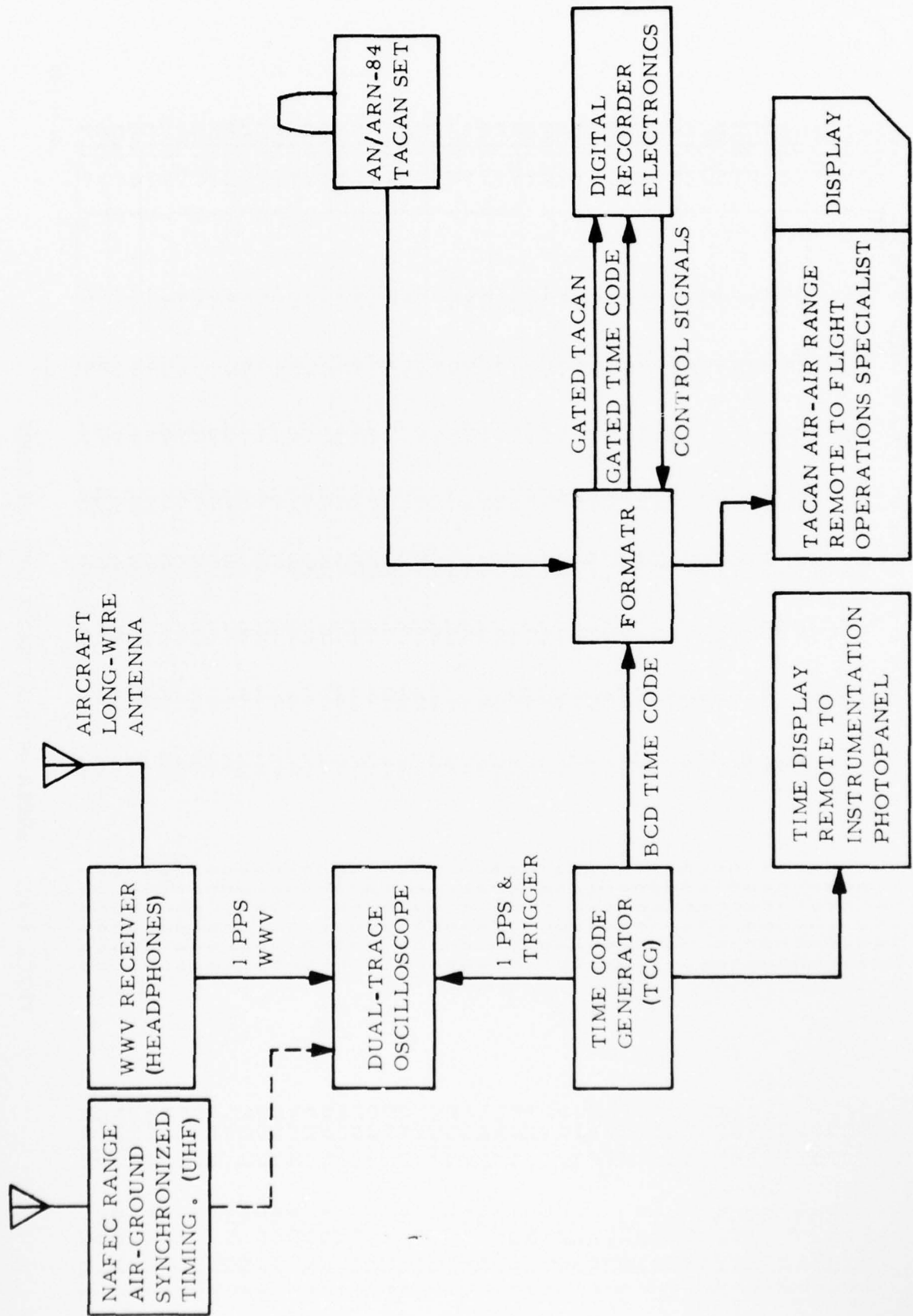

FIGURE 2-18. TACAN AIR-AIR RANGE EQUIPMENT SHOWING TACAN WITH FORMATTER AND TIME CODE/WWV RECEIVER



76-23-2-19

FIGURE 2-19. FUNCTIONAL DIAGRAM OF TACAN AIR/AIR RANGE MEASUREMENT SYSTEM

TACAN TAPE FLT=15 A/C N-376 Q-18 6-3-75  
 RUN 1 FILE 5 PRINT INTERVAL 1.00

TIME	TACAN RANGE	S	W	I	T	C	H	1	2	3	4	5	6	7	ANALOG B	ANALOG RE-CORD	RANGE CHANGE
9 58 37.0	15.7000	0	0	0	0	0	0	-0.	-0.	-0.	-0.	-0.	-0.	-0.	1	15.7000	
9 58 38.0	15.6375	0	0	0	0	0	0	-0.	-0.	-0.	-0.	-0.	-0.	-0.	1	-0.0625	
9 58 39.0	15.4000	0	0	0	0	0	0	-0.	-0.	-0.	-0.	-0.	-0.	-0.	1	-0.2375	
9 58 40.0	15.4500	0	0	0	0	0	0	-0.	-0.	-0.	-0.	-0.	-0.	-0.	1	0.0500	
9 58 41.0	15.3375	0	0	0	0	0	0	-0.	-0.	-0.	-0.	-0.	-0.	-0.	1	-0.1125	
9 58 42.0	15.1375	0	0	0	0	0	0	-0.	-0.	-0.	-0.	-0.	-0.	-0.	1	-0.2000	
9 58 43.0	15.0500	0	0	0	0	0	0	-0.	-0.	-0.	-0.	-0.	-0.	-0.	1	-0.0875	
9 58 44.0	14.8875	0	0	0	0	0	0	-0.	-0.	-0.	-0.	-0.	-0.	-0.	1	-0.1625	
9 58 45.0	14.8000	0	0	0	0	0	0	-0.	-0.	-0.	-0.	-0.	-0.	-0.	1	-0.0875	
9 58 46.0	14.7375	0	0	0	0	0	0	-0.	-0.	-0.	-0.	-0.	-0.	-0.	1	-0.0625	
9 58 47.0	14.5875	0	0	0	0	0	0	-0.	-0.	-0.	-0.	-0.	-0.	-0.	1	-0.1500	
9 58 48.0	14.5000	0	0	0	0	0	0	-0.	-0.	-0.	-0.	-0.	-0.	-0.	1	-0.0875	
9 58 49.0	14.3875	0	0	0	0	0	0	-0.	-0.	-0.	-0.	-0.	-0.	-0.	1	-0.1125	
9 58 50.0	14.2875	0	0	0	0	0	0	-0.	-0.	-0.	-0.	-0.	-0.	-0.	1	-0.1000	
9 58 51.0	14.2375	0	0	0	0	0	0	-0.	-0.	-0.	-0.	-0.	-0.	-0.	1	-0.0500	
9 58 52.0	14.1000	0	0	0	0	0	0	-0.	-0.	-0.	-0.	-0.	-0.	-0.	1	-0.1375	
9 58 53.0	14.0500	0	0	0	0	0	0	-0.	-0.	-0.	-0.	-0.	-0.	-0.	1	-0.0500	
9 58 54.0	13.9500	0	0	0	0	0	0	-0.	-0.	-0.	-0.	-0.	-0.	-0.	1	-0.1000	
9 58 55.0	13.8875	0	0	0	0	0	0	-0.	-0.	-0.	-0.	-0.	-0.	-0.	1	-0.0625	
9 58 56.0	13.7500	0	0	0	0	0	0	-0.	-0.	-0.	-0.	-0.	-0.	-0.	1	-0.1375	
9 58 57.0	13.6500	0	0	0	0	0	0	-0.	-0.	-0.	-0.	-0.	-0.	-0.	1	-0.1000	
9 58 58.0	13.5500	0	0	0	0	0	0	-0.	-0.	-0.	-0.	-0.	-0.	-0.	1	-0.1000	
9 58 59.0	13.4375	0	0	0	0	0	0	-0.	-0.	-0.	-0.	-0.	-0.	-0.	1	-0.1125	
9 59 0.0	13.3000	0	0	0	0	0	0	-0.	-0.	-0.	-0.	-0.	-0.	-0.	1	-0.1375	
9 59 1.0	13.2500	0	0	0	0	0	0	-0.	-0.	-0.	-0.	-0.	-0.	-0.	1	-0.0500	
9 59 2.0	13.1875	0	0	0	0	0	0	-0.	-0.	-0.	-0.	-0.	-0.	-0.	1	-0.0625	
9 59 3.0	13.0375	0	0	0	0	0	0	-0.	-0.	-0.	-0.	-0.	-0.	-0.	1	-0.1300	
9 59 4.0	12.9500	0	0	0	0	0	0	-0.	-0.	-0.	-0.	-0.	-0.	-0.	1	-0.0875	
9 59 5.0	12.8500	0	0	0	0	0	0	-0.	-0.	-0.	-0.	-0.	-0.	-0.	1	-0.1000	
9 59 6.0	12.7875	0	0	0	0	0	0	-0.	-0.	-0.	-0.	-0.	-0.	-0.	1	-0.0625	
9 59 7.0	12.6875	0	0	0	0	0	0	-0.	-0.	-0.	-0.	-0.	-0.	-0.	1	-0.1000	
9 59 8.0	12.5875	0	0	0	0	0	0	-0.	-0.	-0.	-0.	-0.	-0.	-0.	1	-0.1000	
9 59 9.0	12.4875	0	0	0	0	0	0	-0.	-0.	-0.	-0.	-0.	-0.	-0.	1	-0.0875	
9 59 10.0	12.4000	0	0	0	0	0	0	-0.	-0.	-0.	-0.	-0.	-0.	-0.	1	-0.1000	
9 59 11.0	12.3000	0	0	0	0	0	0	-0.	-0.	-0.	-0.	-0.	-0.	-0.	1	-0.1000	
9 59 12.0	12.2375	0	0	0	0	0	0	-0.	-0.	-0.	-0.	-0.	-0.	-0.	1	-0.0625	
9 59 13.0	12.0875	0	0	0	0	0	0	-0.	-0.	-0.	-0.	-0.	-0.	-0.	1	-0.1500	
9 59 14.0	12.0000	0	0	0	0	0	0	-0.	-0.	-0.	-0.	-0.	-0.	-0.	1	-0.0875	
9 59 15.0	11.9000	0	0	0	0	0	0	-0.	-0.	-0.	-0.	-0.	-0.	-0.	1	-0.1000	
9 59 16.0	11.7875	0	0	0	0	0	0	-0.	-0.	-0.	-0.	-0.	-0.	-0.	1	-0.1125	
9 59 17.0	11.6375	0	0	0	0	0	0	-0.	-0.	-0.	-0.	-0.	-0.	-0.	2	-0.1500	
9 59 18.0	11.5875	0	0	0	0	0	0	-0.	-0.	-0.	-0.	-0.	-0.	-0.	2	-0.0500	
9 59 19.0	11.4875	0	0	0	0	0	0	-0.	-0.	-0.	-0.	-0.	-0.	-0.	2	-0.1000	
9 59 20.0	11.3875	0	0	0	0	0	0	-0.	-0.	-0.	-0.	-0.	-0.	-0.	2	-0.1000	
9 59 21.0	11.3375	0	0	0	0	0	0	-0.	-0.	-0.	-0.	-0.	-0.	-0.	2	-0.0500	
9 59 22.0	11.2000	0	0	0	0	0	0	-0.	-0.	-0.	-0.	-0.	-0.	-0.	2	-0.1375	
9 59 23.0	11.1000	0	0	0	0	0	0	-0.	-0.	-0.	-0.	-0.	-0.	-0.	2	-0.1000	
9 59 24.0	11.0375	0	0	0	0	0	0	-0.	-0.	-0.	-0.	-0.	-0.	-0.	2	-0.0625	
9 59 25.0	10.9500	0	0	0	0	0	0	-0.	-0.	-0.	-0.	-0.	-0.	-0.	2	-0.0875	
9 59 26.0	10.8375	0	0	0	0	0	0	-0.	-0.	-0.	-0.	-0.	-0.	-0.	2	-0.1125	

76-23-2-20

FIGURE 2-20. SAMPLE OF TACAN "QUICK LOOK" PRINTOUT

made above and below to calibrate and check any differences in each aircraft system. This aircraft system check, also allowed the CAS operators to in-flight check their equipment operations.

After each flight, the film or tape was logged in by team personnel and delivered to the appropriate processing facility. The film was delivered to the photographic laboratory, developed, reviewed, and released to film reduction and preparation. The tape from the Kennedy recorder, which is also an input to the CAS List Program (reference 8) is a low-density (200 bits per inch), binary (odd parity) tape. Encounter runs were separated by single end of files, with the end of data for a tape noted by five end of files back to back. Records were variable length containing a maximum of 1,024 six-bit characters or 171 IBM 7090 computer words. Each record started with a START-OF-EPOCH message and ended with a maneuver indicator (MI) message. There was one START-OF-EPOCH, OMS, OMS+4 and MI message, and at least one DATA MESSAGE SLOT message in each record. Also the UNSELECTED INTRUDER message transmitted by the CAS ground station test transmission on odd epochs was recorded, see table 2-5. This tape was released for processing by a IBM 7090 computer, and an output listing of unpacked binary CAS data was available for "quick-look" analysis as the sample shown in figure 2-21. Table 2-3 is a content list along with definitions (table 2-4) for the message printout decoding.

The CAS List Program tape and derived sample printouts shown in figures 6-19 and 6-20 were format suitable and used in processing other analysis program, such as COM Mod (Range, Reliability) and COM SYNCRO as shown in figure 6-21, 6-23, and 6-24, and CAS Merge, shown in figure 7-2.

TABLE 2-5. TEST MODE INFORMATION. GROUND STATION TEST TRANSMISSIONS FOR ODD EPOCHS

Test Sequence No.	Message Slot	RF	Range (nmf)	Range Rate 2 (knots)	Diff. Alt. 3 (ft)		Biphase		Sync @
					Rate 2	Alt. 3	4	5	
1	79	F4	19.0	2330	-	3500	00-0079	ts	
2	207	F4	3.6	000	+	800	00-0207	ts	
3	335	F4	24.5	2330	-	3200	00-0335	ts	
4	463	F4	0.3	-	-	800	00-0463	ts	
5	590	F3	12.6	1165	+	1700	00-590	ts	
6	718	F3	3.8	350	-	200	00-718	ts	
7	846	F3	10.0	1165	-	500	00-846	ts	
8	974	F3	1.5	350	-	500	00-974	ts	
9	1101	F2	14.5	2330	-	200	63-2047	None	
10	1229	F2	1.5	350	+	200	63-2047	None	
11	1357	F2	7.0	1165	+	500	63-2047	None	
12	1485	F2	3.8	350	+	500	63-2047	None	
13	1612	F1	No G/S Transmission, A/C self check						
14	1740	F1	3.8	350	+	1200	00-1740	ts	
15	1868	F1	17.1	1165	+	2000	00-1868	ts	
16	1996	F1	7.5	350	-	1500	00-1996	ts	

- NOTE:
1. No test transmissions during even epochs.
  2. -, indicates opening range rate.
  3. +, indicates intruder (G/S signal) above own altitude. Own altitude set at 4000 feet for these tests.
  4. Hierarchy
  5. Sync address

AD-A037 435

NATIONAL AVIATION FACILITIES EXPERIMENTAL CENTER ATL--ETC F/G 1/2  
FLIGHT TEST AND EVALUATION OF MDEC (MCDONNELL DOUGLAS ELECTRONI--ETC(U)  
FEB 77 T J TURNOCK, H SCOZZAFAVA

UNCLASSIFIED

FAA-NA-76-23

FAA-RD-75-231

NL

2 of 3

ADA037435

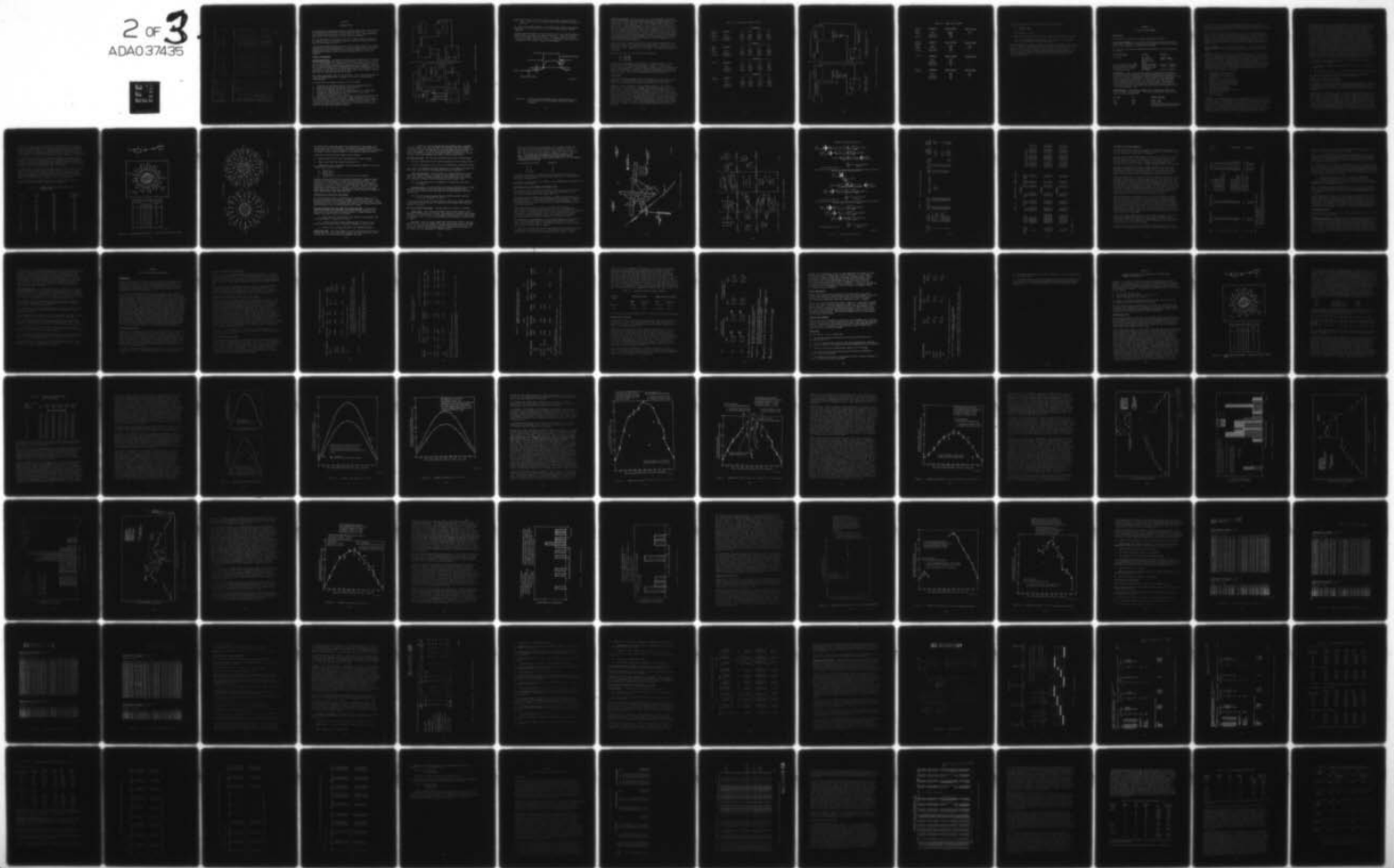

2 OF 3

ADA037435

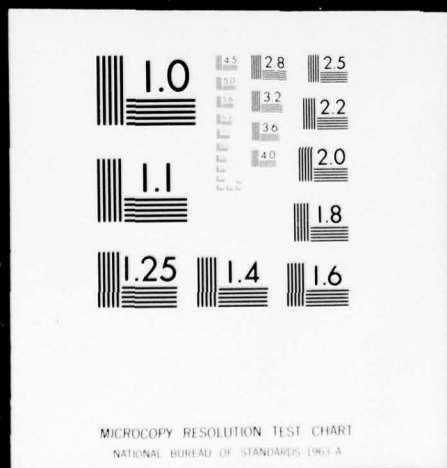

CAS MAGNETIC TAPE 9-2-75 FLIGHT NO. 49 Q143 N377  
 FILE 1 2 RECORD 74  
 1 2 3 4 5 6 7 8 9 10 11 12 13 14 15 16 17 18 19 20 21 22 23 24 25 26 27 28 29  
 START 1 21975 9 605 14 8 424  
 JMN 3 1285 81 0 0 1 0 1 1 0 1 1 0 0 1 0 0 1 0 1 1 0 0 1 196 0 0  
 JMS 5 0 0 0  
 INFR 4 1546 0 0 0 1 0 1 1 0 0 1 1 0 0 1 0 1 1 0 0 0 48 000 0 -0 0 1 2  
 DATA 2 1773 87 0 0 1 0 1 1 0 1 1 0 0 1 0 0 1 0 1 1 0 0 2 524 0 -27 1 0 36  
 MI 6 0 0 1 0 0 0 0 0 0 1 0

CAS MAGNETIC TAPE 9-2-75 FLIGHT NO. 49 Q143 N377  
 FILE 1 2 RECORD 75  
 1 2 3 4 5 6 7 8 9 10 11 12 13 14 15 16 17 18 19 20 21 22 23 24 25 26 27 28 29  
 START 1 41975 9 606 14 8 454  
 INFR 4 79 0 0 0 0 1 0 1 1 0 1 1 0 0 1 0 1 1 1 0 0 0 67 126 0 -0 0 1 2  
 INFR 4 207 0 0 0 0 1 0 1 1 0 1 1 0 0 1 0 1 1 1 0 0 0 52 524 0 -0 0 1 2  
 INFR 4 345 0 0 0 0 1 0 1 1 0 1 1 0 0 1 0 1 1 1 0 0 0 73 420 0 -0 0 1 2  
 INFR 4 403 0 0 0 0 1 0 1 1 0 1 1 0 0 1 0 1 1 1 0 0 0 49 254 0 -0 0 1 2  
 INFR 4 59 0 0 0 0 1 0 1 1 0 1 1 0 0 1 0 1 1 1 0 0 0 61 053 0 -0 0 1 2  
 INFR 4 718 0 0 0 0 1 0 1 1 0 1 1 0 0 1 0 1 1 1 0 0 0 52 114 0 -0 0 1 2  
 INFR 4 846 0 0 0 0 1 0 1 1 0 1 1 0 0 1 0 1 1 1 0 0 0 58 032 0 -0 0 1 2  
 INFR 4 974 0 0 0 0 1 0 1 1 0 1 1 0 0 1 0 1 1 1 0 0 0 50 453 0 -0 0 1 2  
 INFR 4 1101 0 0 0 0 1 0 1 1 0 1 1 0 0 1 0 1 1 1 0 0 0 69 003 0 -0 0 1 2  
 INFR 4 1229 0 0 0 0 1 0 1 1 0 1 1 0 0 1 0 1 1 1 0 0 0 50 453 0 -0 0 1 2  
 JMN 3 1285 81 0 0 1 0 1 1 0 1 1 0 0 1 0 0 1 0 1 1 0 0 1 194 1 0  
 JMS 5 1419 0 0  
 INFR 4 1337 0 0 0 0 1 0 1 1 0 1 1 0 0 1 0 1 1 1 0 0 0 55 154 0 -0 0 1 2  
 INFR 4 1485 0 0 0 0 1 0 1 1 0 1 1 0 0 1 0 1 1 1 0 0 0 52 751 0 -0 0 1 2  
 INFR 4 1546 0 0 0 0 1 0 1 1 0 1 1 0 0 1 0 1 1 1 0 0 0 48 164 0 -0 0 1 2  
 INFR 4 1746 0 0 0 0 1 0 1 1 0 1 1 0 0 1 0 1 1 1 0 0 0 52 783 0 -0 0 1 2  
 DATA 2 1773 87 0 0 1 0 1 1 0 1 1 0 0 1 0 0 1 0 1 1 0 0 2 233 0 -27 1 0 36  
 INFR 4 1862 0 0 0 0 1 0 1 1 0 1 1 0 0 1 0 1 1 1 0 0 0 66 032 0 -0 0 1 2  
 INFR 4 1934 0 0 0 0 1 0 1 1 0 1 1 0 0 1 0 1 1 1 0 0 0 55 472 0 -0 0 1 2  
 MI 6 0 0 1 0 0 0 0 0 0 0 1 1

FIGURE 2-21. SAMPLE OF CAS "QUICK LOOK" PRINTOUT

## CHAPTER 3

### LABORATORY TEST

The measurements of transmitter power and receiver sensitivity on both the CAU and Mini-CAS were taken during aircraft inspection "down time." This time period usually occurred after a 2-month period of flying. Measurements were conducted by NAFEC technicians and MDEC contractor personnel.

With the completion of the flight program, the overall receiver sensitivity was constant, with the exception of Mini-CAS 1 which had a deterioration of about 4.3 dB (chapter 10, note 1).

A noticeable deterioration was observed on both CAU and Mini-CAS power output readings, which may be explainable by the visual judgment used in measurement. Although power output deficiencies were apparent, analysis of the RF link communications (range, reliability, and synchronization) were more than adequate.

#### METHOD OF MEASUREMENT.

RECEIVER SENSITIVITY. The receiver sensitivity measurements were accomplished with the CAU in backup mode (BUM) and the Mini-CAS in stand-by sync. In the case of the Mini-CAS, it was necessary for it to receive an epoch-start triad from the ground station or CAU before measurements were attempted. Figure 3-1 was the physical setup used for determining the receiver sensitivity of a CAU or Mini-CAS. As can be seen, the upper antenna was the RF feed-point for each equipment, with the lower antenna being dummy loaded. This affected only the CAU, since the Mini-CAS uses only one antenna.

Only slight differences exist in the procedures. When inhibiting the CAU, an X-MIT and INHIBIT switch must be engaged on the back of the Model 2000 instrumentation.

An outline that was followed consisted of the following:

1. Triggering the UHF signal generator and scope from test point  $t_0$ ;
2. Power setting and zero setting the signal generator;
3. Setting the frequency control switch to F1;
4. Setting the frequency dial on the signal generator to F1 (1600 MHz);
5. Setting the output attenuator dial to about 250 mV for 60 dB;
6. Setting the sync selector for X1; and
7. Adjusting the scope so that at least eight successive time slots can be seen on the sweep (1.5 ms per time slot). Note the presence of receiver switching transients in both DET VIDEO and THRESH VIDEO on vertical channels of the scope. Test points are located on the instrumentation panel. The switching transients occur slightly ahead of  $t_0$  of each slot and should be stable on the scope when properly triggered.

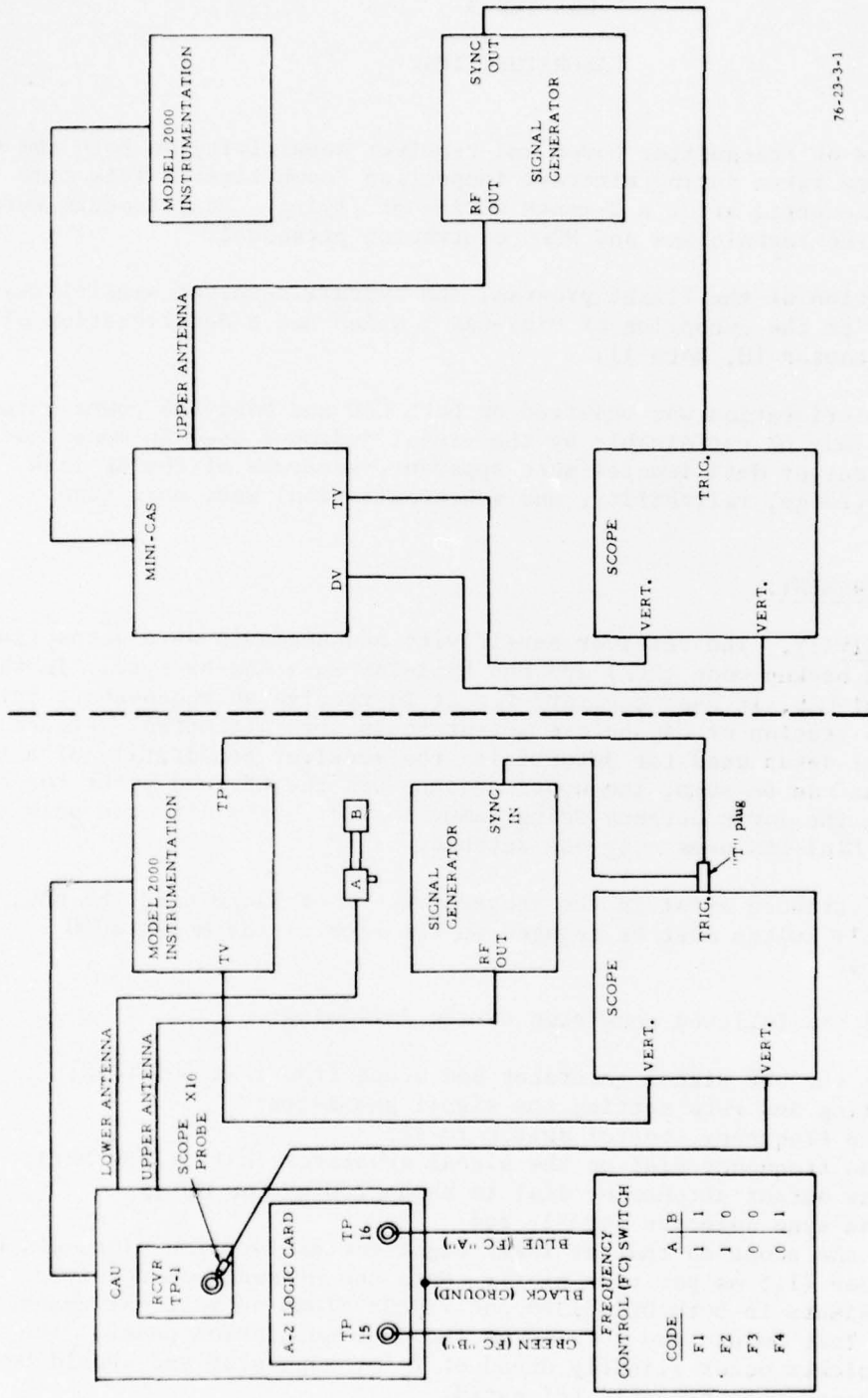

76-23-3-1

- TO
- TP-1 D. V. DETECTED VIDEO
- TV THRESHOLD VIDEO
- A COAXIAL COUPLER (-20 dB)
- B DUMMY LOAD (50 ohm)

FIGURE 3-1. RECEIVER SENSITIVITY TEST SETUP

NOTE: Ignore pulsed signals which appear in receiver during OMS and TEST SLOTS. These are due to exciter pregate, which normally saturates the receiver.

8. Adjust the signal generator for a pulsed output (pulse width, approximately 10  $\mu$ s with a delay of 10  $\mu$ s) and a PRF of 200 to 300 at -80 dBm (1600 MHz).

A signal should be observed in every fourth time slot on both DET VIDEO and THRESH VIDEO scope displays as shown in figure 3-2. Adjust the frequency slowly through 1605, 1610, and 1615 MHz. The signal should be observed to progress in steps through the time slots, appearing in every fourth slot corresponding to the proper "frequency-of-the-moment."

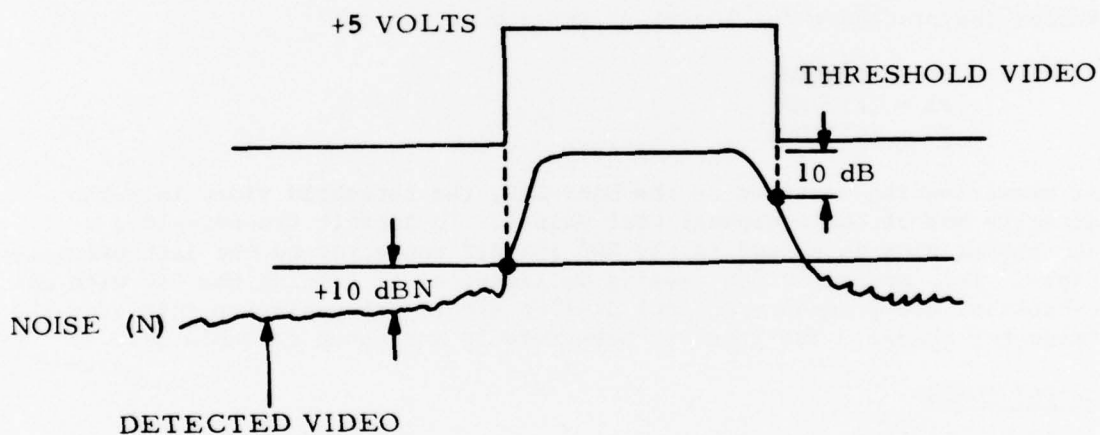

76-23-3-2

FIGURE 3-2. DETECTED VIDEO AND THRESHOLD VIDEO, SCOPE ADJUSTED TO 5.0  $\mu$ S/DIVISION WITH OUTPUT ATTENUATOR ADJUSTED FOR CLEAN WAVESHAPES

THRESHOLD SENSITIVITY. On each of the four frequencies, adjust the signal level so that signal threshold envelope displayed on THRESHOLD VIDEO becomes a solid pulse with less than 1-percent breakup (dropout below threshold as ascertained by visual judgment). This is the minimum usable sensitivity of the receiver. (Note: The threshold is actually set at the point where the pulse is seen to obtain threshold 50 percent of the time, and it should occur near the tangential sensitivity level. If the threshold is set too close to the receiver peak noise, excessive threshold triggering on noise will occur; so-called high "false alarm" rate. This may tie-up the logic signal verifier to the extent that valid signals cannot be decoded. It will never generate a "false alarm" in the sense of permitting a false range pulse to be verified. Receiver threshold may be set to any desired level by an adjustment in the Video/Biphase Demodulator module).

Record the output attenuator dial; this is the receiver sensitivity for the frequency selected. For finding the tone signal level at the antenna port subtract all known cable losses from the signal generator readings. Example: Cable loss is 2 dB. Signal generator reads dBm. True signal at antenna port is -88 dBm.

Repeat the procedure for the other three frequencies:

F2 = 1605 MHz  
F3 = 1610 MHz  
F4 = 1615 MHz

In measuring the receiver on the Mini-CAS, the threshold video is taken directly out of the equipment test points. To inhibit transmission, a shortening plug is placed in the MOD INHIBIT connector on the instrumentation panel. This procedure for testing is identical to testing the CAU with one exception, the frequency control dial on the signal generator initiates the frequency change. The receiver measurements are shown in table 3-1.

#### OUTPUT POWER.

In the output power measurement, the test procedures are identical for both equipments. The XMIT INHIBIT switch is activated in power checking the range and altitude pulse, which should be within  $\pm 1$  dB of each other.

Figure 3-3 is the setup used for the power measurements. The variable attenuator is set for 60 dB. A trigger from the OMS equipment test point is used for sync. The two pulses are then displayed on the scope, and by adjusting the variable attenuator are brought to within  $\pm 1$  dB of each other. After the pulses are set, using the peak power meter with a built-in calibrator and detector, observe the range and altitude pulse on the scope. (Caution: approximately 40 dB of calibrated attenuation must be connected between the upper antenna port and the peak-power meter (or detector) to prevent damage to the meter or detector.) The variable attenuator was then read, and adding 19.5 dB for coupler loss, and 1 dB for upper antenna, the total power figure was found. The power in watts was then computed from dBm and recorded in table 3-2.

TABLE 3-1. RECEIVER SENSITIVITY (IN dB)

	<u>Equipment</u>	<u>Frequency</u>			
		<u>F1</u>	<u>F2</u>	<u>F3</u>	<u>F4</u>
Before Flight Test	CAU 1	-88.1	-88.6	-88.6	-88.4
8-27-74	CAU 2	-89.3	-90.0	-90.0	-89.3
to	Mini-CAS 1	-79.6	-79.6	-79.6	-79.6
9/13-74	Mini-CAS 2	-80.5	-80.5	-79.6	-78.7

	<u>Equipment</u>	<u>Frequency</u>			
		<u>F1</u>	<u>F2</u>	<u>F3</u>	<u>F4</u>
Midway Thru Test	CAU 1	-90.5	-90.5	-90.5	-90.5
6-26-75	CAU 2	-89.0	-88.5	-89.5	-89.0
to	Mini-CAS 1	-78.8	-78.8	-78.8	-78.8
6-27-75	Mini-CAS 2	-81.8	-81.8	-81.8	-80.8

	<u>Equipment</u>	<u>Frequency</u>			
		<u>F1</u>	<u>F2</u>	<u>F3</u>	<u>F4</u>
9-17-75	CAU 1	-89.0	-88.5	-89.0	-88.0
	CAU 2	-87.5	-88.0	-87.5	-87.5
	Mini-CAS 1	-76.0	-75.0	-75.0	-75.0
	Mini-CAS 2	-80.0	-80.0	-79.5	-79.0

	<u>Equipment</u>	<u>Frequency</u>			
		<u>F1</u>	<u>F2</u>	<u>F3</u>	<u>F4</u>
Final 10-20-75	CAU 1	-89.0	-88.5	-89.0	-88.5
	CAU 2	-89.0	-89.5	-91.0	-90.0
	Mini-CAS 1	-75.0	-74.0	-75.0	-76.5
	Mini-CAS 2	-79.5	-80.0	-81.5	-81.0

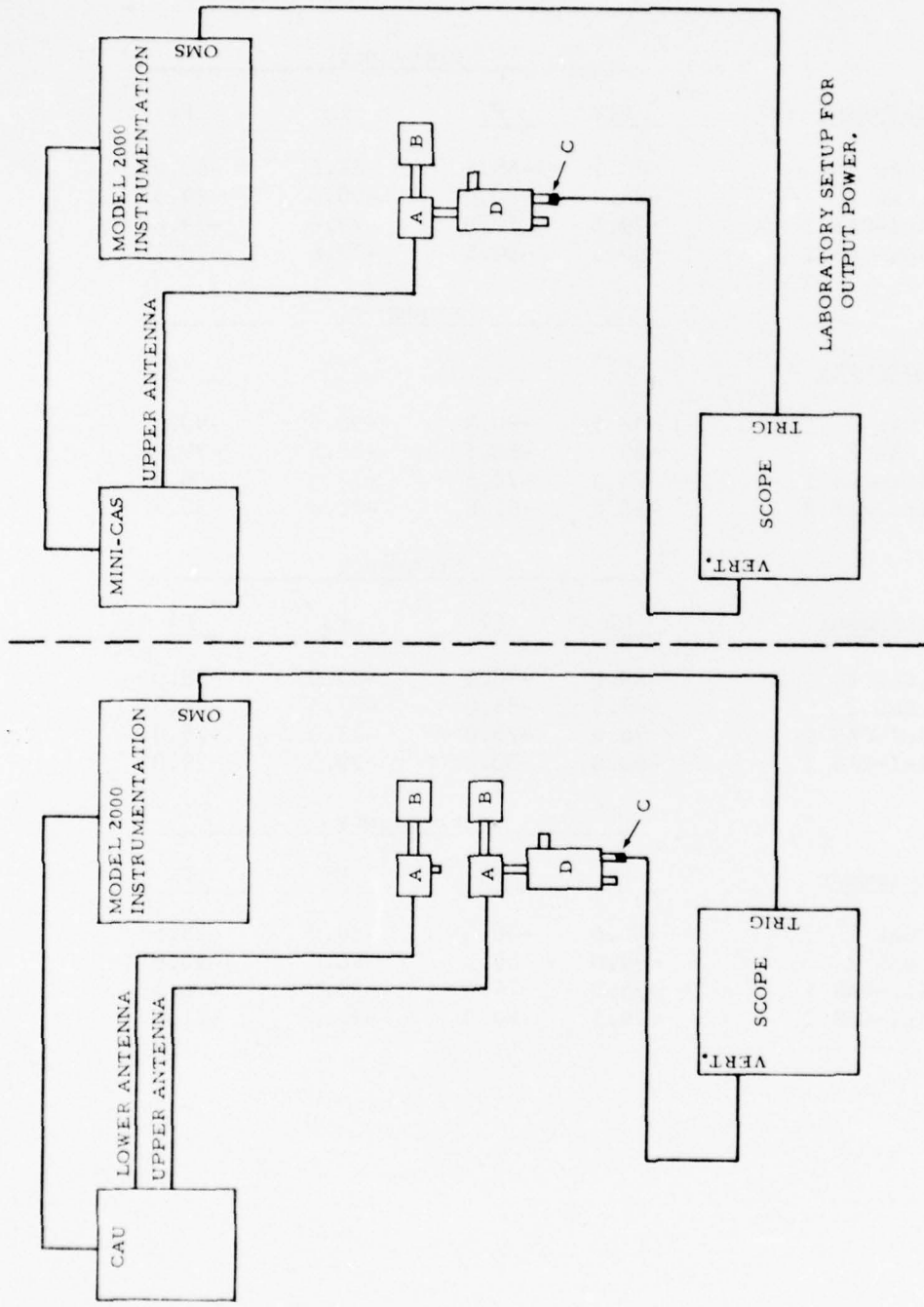

A COAXIAL COUPLER (-20 dB)  
 B DUMMY LOAD (50 ohm)

C O, dBm DETECTOR (+27mV OR -18 mV)  
 D VARIABLE ATTENUATOR

76-23-3-3

FIGURE 3-3. LABORATORY SETUP FOR OUTPUT POWER

TABLE 3-2. POWER OUTPUT (WATTS)

	<u>Equipment</u>	<u>Upper Antenna</u>	<u>Lower Antenna</u>
Before Flight Test	CAU 1	1,622	863
8-27-74	CAU 2	2,000	-
to	Mini-CAS 1	108	-
9-13-74	Mini-CAS 2	155	-
Midway Through Test	<u>Equipment</u>	<u>Upper Antenna</u>	<u>Lower Antenna</u>
6-26-75	CAU 1	708	447
to	CAU 2	1,413	1,122
6-27-75	Mini-CAS 1	339	-
	Mini-CAS 2	269	-
9-17-75	<u>Equipment</u>	<u>Upper Antenna</u>	<u>Lower Antenna</u>
	CAU 1	446	-
	CAU 2	831	-
	Mini-CAS 1	224	-
	Mini-CAS 1	200	-
Final 10-20-75	<u>Equipment</u>	<u>Upper Antenna</u>	<u>Lower Antenna</u>
	CAU 1	224	200
	CAU 2	724	282
	Mini-CAS 1	107	-
	Mini-CAS 2	191	-

Nominal antenna losses used in computing the dBm reading were:

CAU on upper = 1 dB  
lower = 2 dB

Mini-CAS upper = 0.8 dB

The combined flight and laboratory time of operation was recorded as follows:

CAU 1 = 1,134 hours, CAU 2 = 835 hours. (Recording of each equipment was by an internal power-actuated time meter.)

Starting with the acceptance in October 1974, when the approximate operational time was 200 hours. Subtracting out the acceptance time would leave an elapsed time of 934 hours for CAU 1 and 635 hours for CAU 2. The difference of 300 hours is accountable; during the design checkout on serial number 01 and 02 tape interface, CAU 1 was used exclusively by ANA-140 personnel. Mini-CAS unit operation, based on flight logs and laboratory testing, totaled 400 operating hours.

CHAPTER 4

FLIGHT TEST PLAN SUMMARY

INTRODUCTION.

The details of the flight test outline are found in reference 9.

FLIGHT CONSIDERATIONS. Due to limited sophisticated airborne navigation and communication's equipment, procedures were implemented to assure that desired airspace was available for use during live testing.

The following areas and associated controlling agencies were used throughout the testing:

<u>Controlling Agency</u>	<u>Facility</u>	<u>Airspace</u>
N.Y. ARTCC	ACY VORTAC Sea Isle City Waterloo (ATR) VORTAC	35-nmi Radius 5,000 - 15,000 ft
N.J. Air National Guard (ANG)	Warren Grove Range	Surface - 10,000 ft
Lakehurst Naval Air Station	Warning Area 107	Surface - 15,000 ft
Patuxent Naval Air Station	Warning Area 108	
ACY Approach Control	ACY VORTAC	60 nmi to 5,000 ft

COORDINATION. Early in the program, appropriate agencies were contacted by the flight operations specialist and mission coordinator and were given a briefing of the overall program with associated plan views of the desired flight patterns and airspace requirements. Direct contact with the appropriate controlling agency was made from 3 to 7 days prior to a specific flight. Final coordination was effected 1 day before the flight. Any change in flight patterns, airspace requirements, or departure or arrival times was accomplished by phone to the appropriate agency mission coordinator prior to the proposed departure time.

COMMUNICATIONS. Three separate communication channels were required for effective mission accomplishment. This initially presented a minor problem due to aircraft configuration.

<u>A/C Type</u>	<u>No.</u>	<u>Cockpit Equipment</u>
G159	N376	2 VHF, 1 UHF
G159	N377	2 VHF, 1 UHF
CV880	N42	2 VHF (an additional VHF transceiver was installed in the cabin area)

When using N376 and/or N377, the following communications' procedures applied: one VHF, air-to-ground for Air Traffic Control, one VHF air-to-air and air-to-ground for test personnel, one UHF channel for flight crew coordination, cockpit to cockpit.

When using N42 with either or both N376 or N377, the following communications' procedures applied: N376 and N377, one VHF for flight crew coordination, cockpit to cockpit; one VHF, air-to-ground and air-to-air for test personnel; one UHF air-to-ground for air traffic control, N42, one VHF, air-to-ground for air traffic control; one VHF for flight crew coordination, cockpit to cockpit; one VHF (rear cabin), air-to-air and air-to-ground for test personnel.

SPECIAL EQUIPMENT. All aircraft were equipped with a 4096 transponder with altitude encoder; discrete settings were used as requested by air traffic control.

PREFLIGHT. Several days prior to any scheduled flight, the flight operation's specialist presented a detailed plan of flight requirements to the project pilot. All apparent problem areas were discussed and resolved, resulting in a final briefing guide. Two hours prior to scheduled block time, the flight operation's specialist reviewed aircraft status, crew assignments, and obtained from the national weather service, a weather briefing. This information, together with detailed flight patterns, was incorporated into separate briefing packages for each flight crew. One hour prior to scheduled block time, the assigned project pilot presented a formal briefing to all pilot personnel, encompassing the following:

1. Flight Plan Information/Waivers,
2. A/C Number(s), Fuel Load,
3. Flight/Project Crew Assignment,
4. Block Times,
5. Lead A/C - Taxi/Takeoff Sequence,
6. Patterns and Positioning Procedures,
7. Altitudes/Airspeeds - Calibration,
8. Communication Frequencies and Use,
9. Restricted/Warning Areas,
10. CAS Indicator Commands,
11. Vertical Avoidance Maneuver Limits,
12. Tracking Requirements,
13. Weather, and
14. ATC Coordination.

IN-FLIGHT. During actual flight, the flight operation's specialist occupied the "jump" seat in the designed control aircraft. This was determined by which aircraft during the flight would be in a position the maximum percentage of time to observe the other aircraft during maneuvers and crossovers. Relative positions of all project aircraft within the airspace were continuously determined by the specialist/controller by monitoring the ATC frequency, the cockpit to cockpit frequency, the test frequency, and observing navigation instruments in the control aircraft, the flight operation's specialist

transmitting on the test and cockpit frequencies, called the start, crossover (when applicable) and the end of each run. The start and end-of-run determination were accomplished by observing DME distance to the fix, relative bearing of the RMI needles to the fix, and radio transmissions of the designated aircraft (nonmaneuvering) indicating distance and position to the fix, in 1-mile increments. Crossovers were determined in the following manner: (1) by visually observing each aircraft at the instant of the actual crossover; (2) observing the air-to-air TACAN distance readout for a minimum distance to the other aircraft; (3) observing the Collins AL101 radio altimeters when positioned so as to crossover another aircraft. When the actual crossover occurred, a momentary "bang" was shown on the indicator, displaying altitude from the lower aircraft; (4) observing the two Collins 51X2 radio magnetic indicators showing relative position in relation to the primary fix. Through cockpit/cockpit communications, the aircraft maneuvered after visual sighting so as to accomplish "station passage" simultaneously as indicated by RMI 180° needle swings; and (5) observing the two Collins 860E3 distance measuring indicators. Continuous callout of mileage to the crossover in 1-mile increments by the nonmaneuvering aircraft, enabled the maneuvering aircraft to maintain the desired position so as to effect simultaneous crossover at the fix. The primary objectives of the flight tests were to determine the following:

1. Communications' range and reliability of the RF link as a function of angle between the flightpath.
2. Communications synchronization reliability and accuracy of the RF ground/air transmissions.
3. Range and range rate (rate of closure between intruder aircraft) accuracy.
4. The ability to provide timely and correct advisories and maneuver commands or warning-time accuracy and display reliability.

#### COMMUNICATION'S RANGE AND RELIABILITY.

The objective of the RF link (communication's range and reliability) tests was to determine the range at which link parameters were established as a function of flight geometry. For instance, at what distance could the target aircraft be identified and tracked for range, range rate, altitude, and other data messages.

All aircraft that constitute a threat to each other must exchange the required communications for collision avoidance. For two aircraft above 10,000 feet with a closure rate of 1,200 knots, the reliable communication range of 15 nmi is considered adequate. The threat range for two aircraft below 10,000 feet with a closing velocity of 600 knots is 8.5 nmi. These ranges apply only to the head-on encounter case, recognizing that for different angles and aircraft speeds, the necessary communication range is proportionately less. Usually a communication's exchange was made well beyond the threat range. This exchange provided altitude, range, and synchronization (hierarchy status) information to the onboard system from the intruder. (See CAS Message Format figure 6-22a).

After initial contact was established with the detected aircraft, and range decreased to ( $R \leq 15$  nmi), a logic screen was lifted, allowing for computation of dR/dT digital range rate. As the range envelope decreased, the maneuver display presented an indication of potential threats to the onboard system. The distances which enabled the pilot to evaluate the hazard and determine the evasive maneuver to maintain safe operation varied according to closing velocity.

The RF link and detection ability is directly dependent on antenna patterns; although, protection must be provided to all equipped aircraft regardless of relative bearing and relative altitudes using the system. The flight tests included all geometries encompassing a 360° coverage around the participating aircraft to test adequate hazard detection for all angles.

The flights were run with the CAU equipment above and below 10,000 feet, with various altitude separation and aircraft velocities. In some cases, tests were run to exercise the above/below 10,000 feet logic mode of operation, which involved three aircraft pattern situations. The Mini-CAS equipment was tested below 10,000 feet, with aircraft velocities ranging from tail chases (below 100 knot approaching) to head-on closure rate of 600 knots.

The patterns which were shown consisted of the "single daisy" (shown in figure 4-1) and "double daisy" (figure 4-2 and table 4-1).

TABLE 4-1. COMMUNICATIONS RELIABILITY--DOUBLE DAISY ENCOUNTER CHART

Encounter	Daisy (20°)	Daisy (15°)	Angle Between Radials
1	90	270	180
2	250	75	175
3	50	240	170
4	210	45	165
5	10	210	160
6	170	15	155
7	330	180	150
8	130	345	145
9	290	150	140
10	90	315	135
11	250	120	130
12	50	285	125
13	210	90	120
14	10	255	115
15	170	60	110
16	330	225	105
17	130	30	100
18	290	195	95
19	90	360	90
72	290	105	175

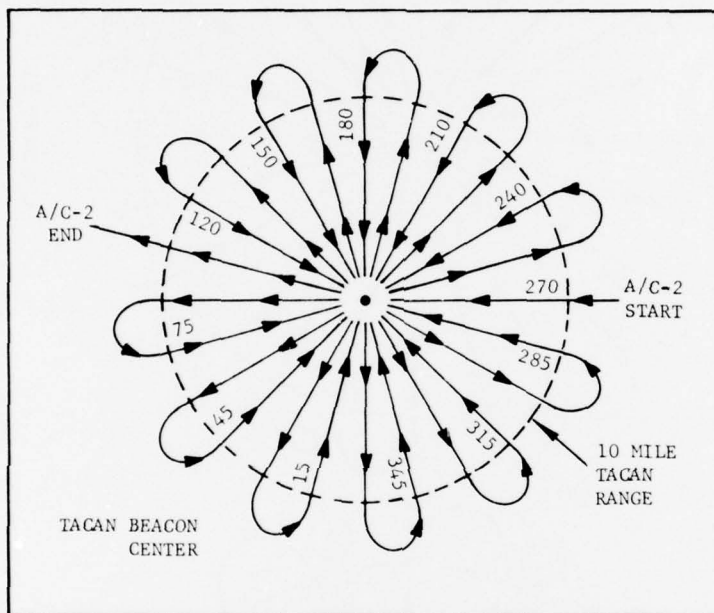
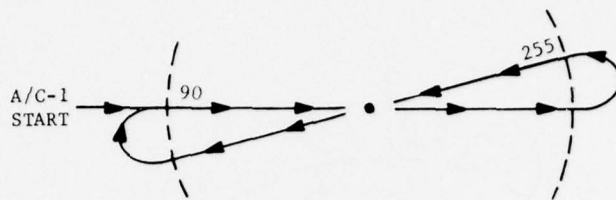

ENCOUNTER NUMBER	RADIALS FLOW		ANGLE BETWEEN RADIALS (DEG)
	A/C-1 (DEG)	A/C-2 (DEG)	
1	90	270	180
2	255	75	180
3	90	240	150
4	255	45	150
5	90	210	120
6	255	15	120
7	90	180	90
8	255	345	90
9	90	150	60
10	255	315	60
11	90	120	30
12	255	285	30
13	90	90	0

76-23-4-1

FIGURE 4-1. COMMUNICATIONS RELIABILITY. SINGLE DAISY OVER A FIGURE EIGHT

10 MILE TAGAN RANGE

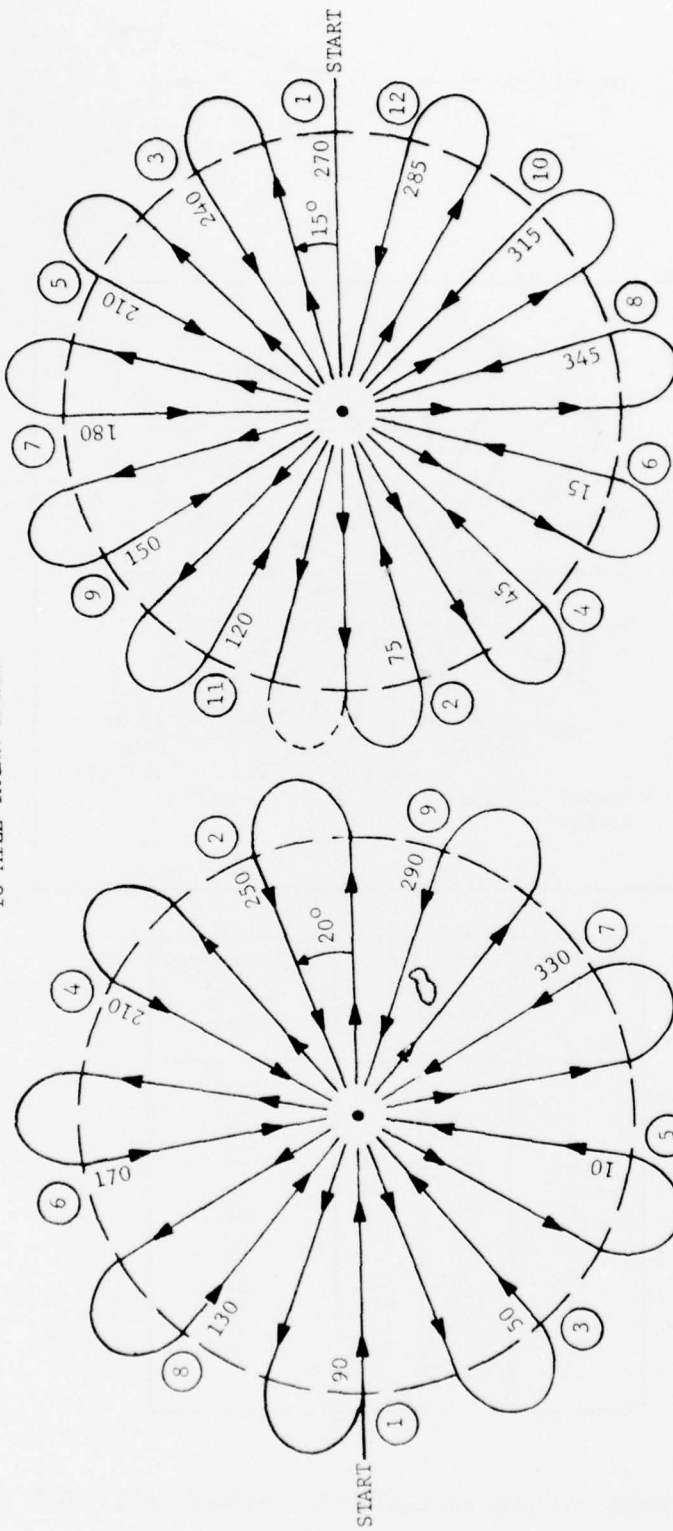

AIRCRAFT NO. 2

76-23-4-2

AIRCRAFT NO. 1

FIGURE 4-2. COMMUNICATIONS RELIABILITY. DOUBLE-DAISY FLIGHT PATTERN

The flights were flown with coaxial line attenuation in the antenna cable for both upper and lower antennas. The amount of attenuation (table 3-1) varied from a low of 1 dB to a high of 3 dB in each aircraft and was determined by equipment station location relative to the antennas (upper and lower).

Primary data derived from the flights were as follows:

1. Range between aircraft after first detection of each encounter,
2. Range versus angle plot between encounter, and
3. Communication link reliability from each encounter--number of lost data communications during each epoch.
  - a. Before Tau 2,
  - b. During Tau 2,
  - c. During Tau 1,
  - d. Combination of total Tau 1, Tau 2, and all the above.

The CAS equipment should be able to detect and evaluate a potential hazard situation in a timely manner to enable safe separation assurance. This necessitates the extrapolation of the data when necessary to "worst-case" combination of aircraft velocities to determine precisely when targets are detected and evaluated in terms of time to collision. Ideally, the system should detect and evaluate, as a minimum, all Tau 2 and Tau 1 situations nearly 100 percent of the time. The results of these tests are in chapter 6 under COMMUNICATIONS RANGE AND RELIABILITY.

#### SYNCHRONIZATION RELIABILITY AND ACCURACY.

The synchronization accuracy and percentage of completion requests in the air/air and ground/air RF link were the data derived from these tests. Air Navigational/Traffic Control Division (ANTC) 117 specifications are as follows: synchronization shall be accomplished with respect to the synchronization donor with an accuracy of  $\pm 5 \mu\text{s}$  with a probability of 0.995.

COLLISION AVOIDANCE UNIT SYNC MODES AND JOIN-UP FROM BUM. The process of join-up (achieving synchronization) is initiated by the reception of the epoch start triad from either the ground station or another synchronized airborne CAU, general rules are as follows:

1. Align time base (coarse adjust) and listen for second-epoch start triad approximately 6 seconds after first.
2. Continue operation in BUM on 1600 MHz (F1) in vacant F1 slot, until first fine resync triad is received in response to an "all-call".
3. Validate sync and begin operation in the LIMITED SYNC mode.

LIMITED SYNC MODE. Protection against false sync acquisition is provided by the following sync logic rules which introduce an intervening mode, called "LIMITED SYNC" mode between BUM and HIERARCHY SYNC mode:

1. A minimum of two sync replies must be validated prior to assuming hierarchy status. The first sync shall fall within a sync time "window," open from  $t_s$  (1419.2  $\mu$ s) minus 600  $\mu$ s to  $t_s$  plus 20  $\mu$ s, and shall result from an all-call request. The sync used to assume hierarchy status must fall within a "deadband,"  $t_s \pm 0.2 \mu$ s, and must be either a ground sync in the odd (ground) epoch or an addressed sync reply in the even (air) epoch.

HIERARCHY SYNC MODE. This mode can be entered only by the following steps:

1. Selecting CAS/FBS mode on the aircraft equipped with the "flying clock", or
2. Properly validating sync at  $t_s \pm 0.2 \mu$ s as described in limited sync mode.

After entry into HIERARCHY SYNC mode, operation is in accordance with ANTC 117 "SYNC Mode" rules with the following modifications and additions:

SYNC DONOR SELECTION. The CAU employs the following additional rule to ensure the requestor does not "lock-up" its sync address logic or a donor that cannot respond or cannot be heard for some reason (e.g., weak receiver, weak transmitter, biphasic decoder malfunction, poor RF link, etc.):

Rule: The logic shall use 0.5 probability in selecting a sync donor for address.

Hierarchy Update. The CAU employs the following additional rule to ensure the hierarchy status is updated only when the time base and oscillator frequency (which generates the time base) are in good agreement with those of the donor:

Rule: Hierarchy shall be updated only by validating proper received sync in the "deadband",  $t_s \pm 0.2 \mu$ s

If sync is received within the sync window,  $t_s \pm 20 \mu$ s, but outside the  $\pm 0.2 \mu$ s "deadband", the CAU corrects its time base (and frequency when using the internal oscillator).

MINI-CAS SYNCHRONIZATION MODES. Mini-CAS operates in either of two modes:

Standby Mode. After turn-ON and warmup, the Mini-CAS remains in this mode until synchronization is attained. Upon receipt of two epoch start triads, approximately 6 seconds apart, the unit begins requesting sync by transmitting a range pulse only. If sync is not attained within 64 epochs, the unit reverts to standby.

Sync Mode. After two resync replies are received and verified, the unit operates in sync mode and transmits both range and altitude pulses. Hierarchy logic is not employed, and biphasic is neither transmitted or processed. Sync was received either from the ground station or from the CAU which employed a 1/N sync logic for responding to "limited" systems.

NOTE: 1/N sync reply rules for the CAU are as follows: during even (airborne) epochs, the synchronized CAU on a random duty cycle, fine sync replies to all aircraft which (a) transmit hierarchy 63 and a 2047 "all call" or (b) do not transmit biphasic data such as the (mini-CAS). The average duty rate shall be 1/N when N is equal to the number of synchronized CAS with hierarchy status better than 63 within communication range. (Own aircraft counts as 1. The 1/N response is approximated as follows:

<u>No. of Hierarchy Aircraft</u>	<u>Value of N</u>
1 - 3	2
4 - 7	4
8 - 15	8
16 and up	16

The flights were flown in conjunction with the communication reliability evaluation, and consisted of long range (50-60 nmi) and short range (0-20 nmi) from the CAS ground station.

The results of these tests are in chapter 6 under COMMUNICATIONS SYNCHRONIZATION RELIABILITY AND ACCURACY.

RANGE, RANGE RATE, AND WARNING TIME ACCURACY TESTS.

The objective of these tests was to estimate the accuracy with which the CAS can measure range and range rate to other aircraft and provide Tau 1 and Tau 2 alarms to the pilot as specified in ANTC 117.

Tests were conducted within a 10-nmi radius of NAFEC using the NAFEC phototheodolites and the Extended Area Instrumentation Radar (EAIR) for independent position measurement. A detailed description of these measurement systems is contained in reference 10. The layout of the NAFEC Instrumentation Range is shown in figure 4-3.

Radio communications were utilized to coordinate test activities on a continuous basis including synchronization of CAS time with Range Control time. Prior to the EAIR flights, the EAIR beacon on the aircraft was calibrated at a specific point on the runway ramp. Visual limitations and general operability of the phototheodolites were also checked prior to takeoff. Preflight calibration of the CAS equipment is discussed in chapter 2.

The instrumentation used initially to measure CAS range and record CAS range, range rate, and warning times was the photopanel described in chapter 2. Midway through the test program, a magnetic tape recording system was added. This system is also described in chapter 2.

The maneuvers associated with the two- and three-aircraft encounters are shown in figures 4-4 and 4-5, respectively, and described in tables 4-2 and 4-3, respectively. The results of the accuracy tests are found in chapter 7.

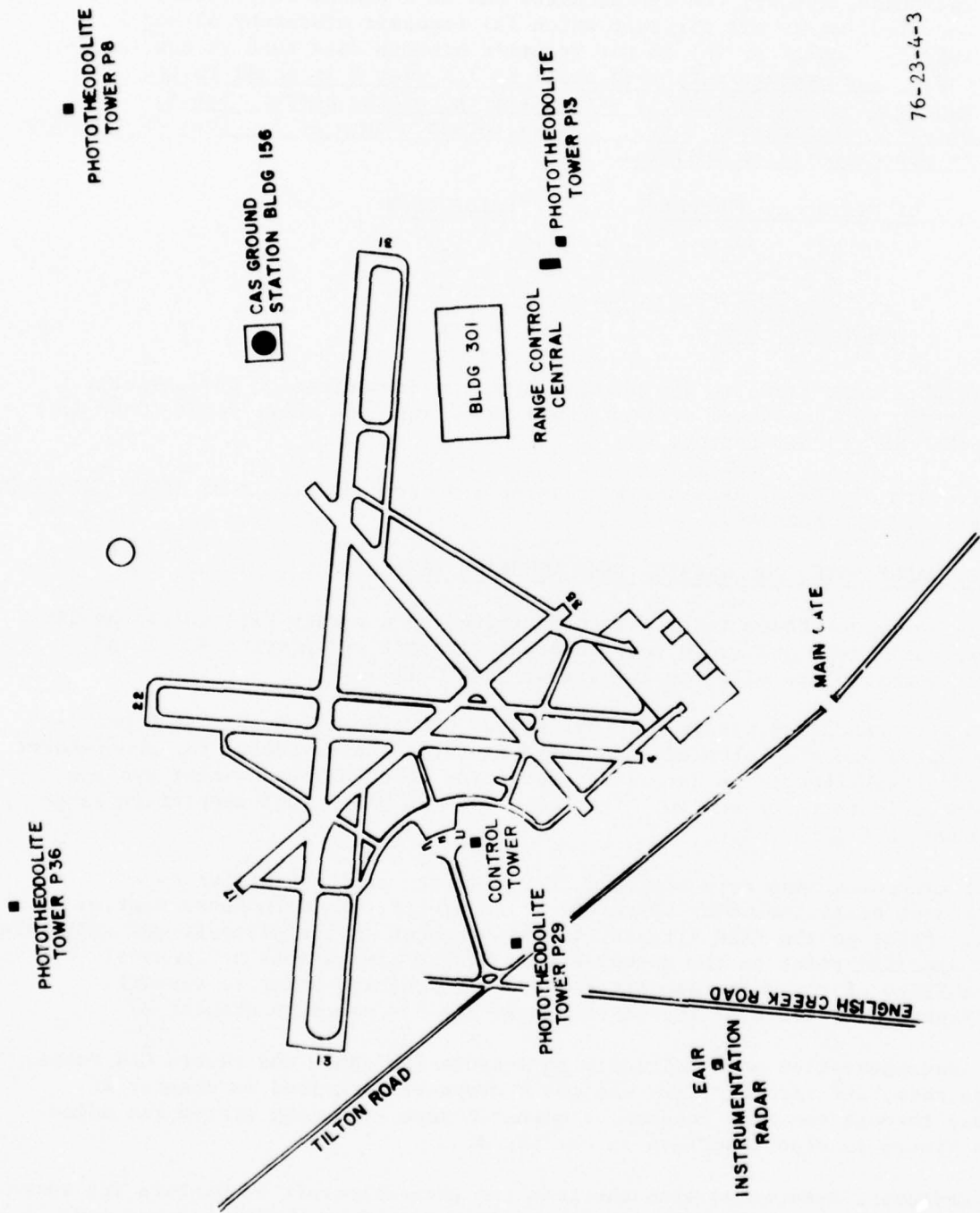

76-23-4-3

FIGURE 4-3. NAFEC INSTRUMENTATION RANGE

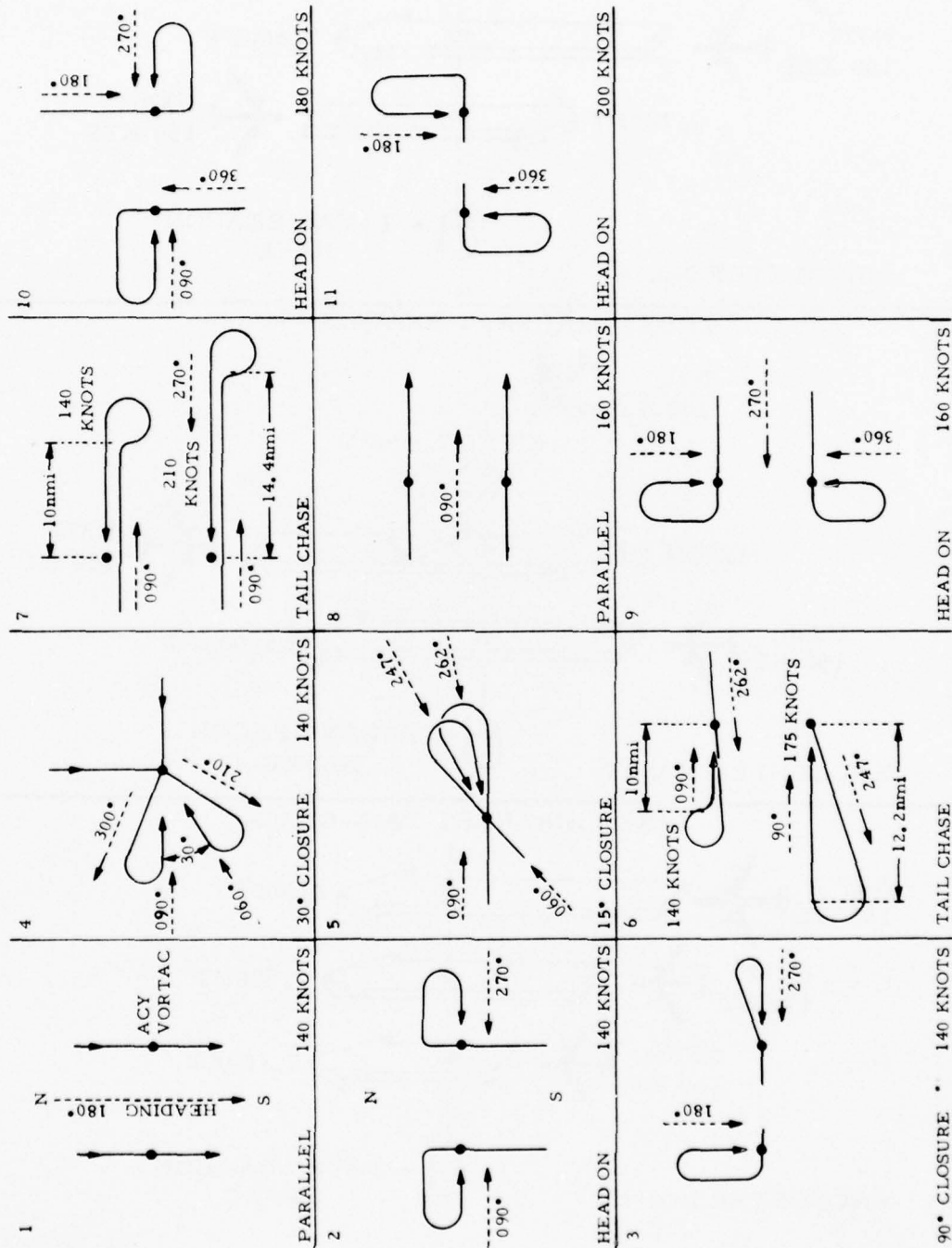

76-23-4-4

FIGURE 4-4. TWO-AIRCRAFT ENCOUNTER

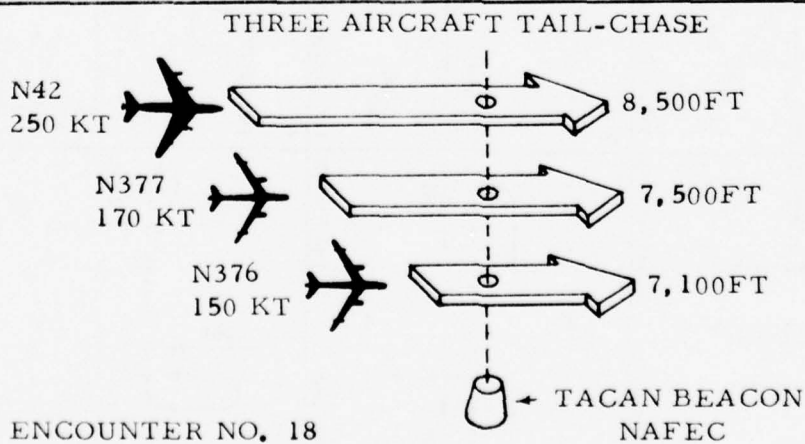
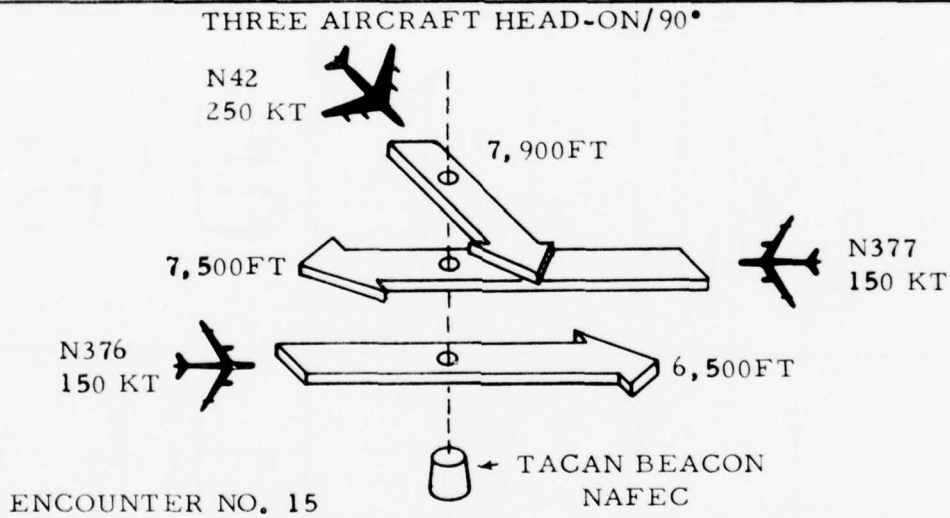
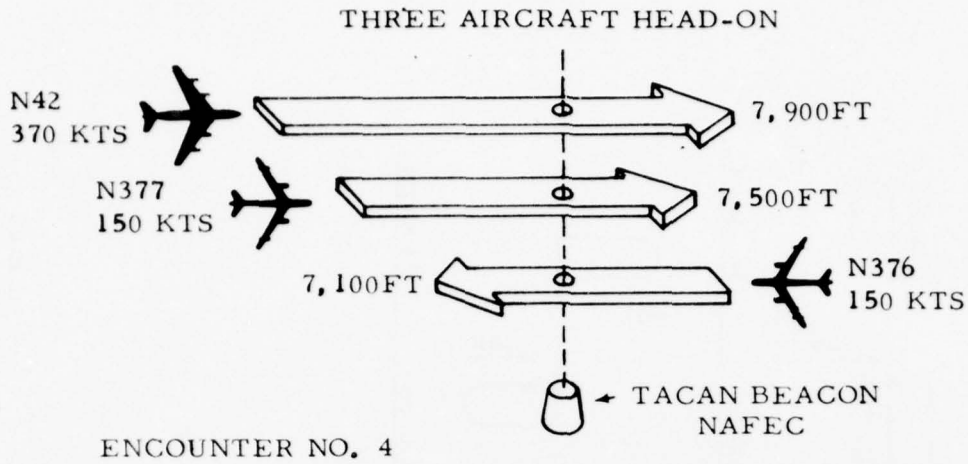

76-23-4-5

FIGURE 4-5. THREE-AIRCRAFT ENCOUNTER

TABLE 4-2. ACCURACY FLIGHTS (TWO-AIRCRAFT)

Encounter No.	Type of Encounter	Altitude (Feet)		Initial A/C Location	Airspeed (Knots)		Range Variation (nmi)	Range Rate (Knots)
		N376	N377		N376	N377 N880		
1	Parallel (1)	4400	4000		140	140		0
2	Head-On	4400	4000	See	140	140	0.2-10	280
3	90° Closing	4400	4000	Figure	140	140	0.2-10	197
4	30° Closing	4400	4000	4-4	140	140		
5	15°	4400	4000		140	140		
6	Tail Chase	4400	4000		140	175	0.2-2	35
7	Tail Chase	4400	4000		140	210	0.2-4	70
8	Parallel (2)	4400	4000		160	160		0
9	Head-On	4400	4000		160	160	0.2-10	320
10	Head-On	4400	4000		180	180	0.2-10	360
11	Head-On	4400	4000		200	200	0.2-10	400

TABLE 4-3. ACCURACY FLIGHTS (THREE-AIRCRAFT)

PATTERN 1

Encounter No.	Type of Encounter	Altitude (feet)			Airspeed (Knots)			Initial A/C Location
		N42	N377	N376	N42	N377	N376	
1	Head-On	9500	7500	5500	370	150	150	S=235°, R=070°, L=235° etc.
2	Head-On	8500	Level	6500	370	150	150	S=235°, R=070°, L=235° etc.
3	Head-On	Level	Level	7100	370	150	150	S=055°, R=250°, L=055° etc.
*4	Head-On	7900	Level	Level	370	150	150	S=235°, R=070°, L=235° etc.
5	Head-On	Level	Level	6500	370	150	150	S=235°, R=070°, L=235° etc.

PATTERN 2

6/7	Head-On/90°	9500	7500	5500	250	150	150	S=325°, R=160°, L=325° etc.
6/8	Head-On/90°	8500	Level	6500	250	150	150	S=145°, R=340°, L=145° etc.
10/11	Head-On/90°	Level	Level	7100	250	150	150	S=235°, R=070°, L=235° etc.
12/13	Head-On/90°	7900	Level	Level	250	150	150	S=325°, R=160°, L=325° etc.
*14/15	Head-On/90°	Level	Level	6500	250	150	150	S=145°, R=340°, L=145° etc.

PATTERN 3

16	Tail-Chase	9500	7500	5500	250	170	150	S=070°, R=070°, L=235° etc.
17	Tail-Chase	8500	Level	6500	250	170	150	S=070°, R=070°, L=235° etc.
*18	Tail-Chase	Level	Level	7100	250	170	150	S=070°, R=070°, L=235° etc.
19	Tail-Chase	7900	Level	Level	250	170	150	S=070°, R=070°, L=235° etc.
20	Tail-Chase	Level	Level	6500	250	170	150	S=070°, R=070°, L=235° etc.

\*See figure 4-5

#### OPERATIONAL TEST (ZONE BOUNDARY).

The operational flight testing was performed to determine the altitude and Tau zone boundaries in addition to equipment capability in generating warning/advisory information against ANTC 117 standards.

There are five maneuver commands generated by the CAU and Mini-CAS: vertical Maneuver (climb or dive), hold altitude, level off, do not turn, and the Vertical Speed Restriction. A description of the maneuver commands can be found in chapter 1 under DISPLAY. A discussion on the maneuvers and advisories are described in chapter 1 THREAT EVALUATION (RANGE AND ALTITUDE).

Altitude zone boundaries are shown in figure 1-18 and 1-19. Tests were performed to determine the CAU and Mini-CAS ability to define the bands. Aircraft were flown in figure-eight patterns in various overtaking runs to determine the coalitude, aircraft above/below, and predicted coalitude bands. Initial conditions and configurations are shown in table 4-4.

Additional flights were to define the Tau zone boundaries and generate warning and advisory indications in avoidance maneuver tests. The CAS threat logic processes, during each slot other than own, quantities of range, range rate, and altitude data received from an aircraft transmitting in that slot. The altitude threat and Tau-range threat status of the other aircraft are evaluated and produce the appropriate logic output. The CAS compares the data and formulates a maneuver command and an advisory output for the pilot display if a Tau zone is violated. At the end of the slot, all logic is cleared and readied to evaluate threat data in the next slot. The values of Tau and minimum range which define the zones are found in figure 1-16.

The following cases were examined: case A is for level flight, nonturning, where two aircraft flew a single-daisy, figure-eight pattern with initial aircraft separation of 400 feet. Each aircraft obeyed the CAS command and after crossover for each encounter, resumed its former altitude. Similar encounters were flown with three aircraft, with two aircraft flying opposite head-on encounters from a figure-eight, and the third aircraft executing the daisy pattern. On these tests, the aircraft were separated by 400 feet and maneuvers were undertaken at any time. This series of test was also utilized in providing data for the communication's range, reliability, and synchronization portions of the program.

Case B is for level flight, turning. These studies demonstrate that loss of warning time between two aircraft, for all angles of approach, can be sufficiently reduced by stopping the turn(s) immediately upon receipt of an appropriate alarm. These maneuvers in the horizontal plane are protected against by means of the no-turn command.

In this test aircraft were flown in parallel flight separated by 500 feet in altitude, and on command, were turned into one another, ignoring the display

TABLE 4-4. ALTITUDE ZONE BOUNDARIES (PATTERN - FIGURE EIGHT)

Run No.	Initial Altitude Separation (feet)	Final Altitude Separation (feet)	Display	Equipment Configuration	Altitude Rate
1	3100	3400 <sup>1</sup>	LVS 2000/No Threat	CAU vs. CAU	See Notes
2	3400 <sup>2</sup>	3100	No Threat/LVS 2000	CAU vs. CAU	
3	2200	1900	LVS 2000/LVS 1000	CAU vs. CAU	
4	1500	1200	LVS 1000/LVS 500	CAU vs. CAU	
5	1000	700	LVS 500/CoAlt (Above)	CAU vs. CAU	
5A	800	500	LVS 500/CoAlt (Above)	CAU vs. CAU	
6	600	-200	CoAlt (Above)/CoAlt (Below)	CAU vs. CAU	
7	-400	+400	CoAlt (Below)/CoAlt (Above)	CAU vs. CAU	
8	3400	500 <sup>4</sup>		CAU vs. CAU	
9	500	3400 <sup>4</sup>		CAU vs. CAU	
10	3400	500 <sup>4</sup>		CAU vs. CAU	
11	500	3400 <sup>4</sup>		CAU vs. CAU	
12	900	1200	LCR 500/No Threat	Mini vs. Mini	
13	900	1200	LCR 500/No Threat	Mini vs. Mini	
14	1200	900	No Threat/LDR 500	Mini vs. Mini	
15	1200	900	No Threat/LDR 500	Mini vs. Mini	
16	1200	600	No Threat/ICR 500/CoAlt	Mini vs. Mini	
17	1200	600	No Threat/LDR 500/CoAlt	Mini vs. Mini	
18	1200	-1200	No Threat/LDR 500/CoAlt (Above)	Mini vs. Mini	
19	-1200	1200	CoAlt Below LDR 500 No Threat (Below)	Mini vs. Mini	
20	1200	600	CoAlt Above/ICR 500 No Threat	Mini vs. Mini	
21	3400	600	No Threat/LDR 500/CoAlt	CAU vs. CAU	
22	500	3400		CAU vs. CAU	
23	3400	600		CAU vs. CAU	
24	600	3400		CAU vs. CAU	

- NOTES:
- Altitude change within each run at 200 ft/min.
  - Altitude change between runs at 600 ft/min.
  - Run 5A below 10,000 feet.  
Run 5 above 10,000 feet.
  - Altitude change for runs 8 and 9 at 600 ft/min and runs 10 and 11 at 1,100 ft/min.
  - Xmit Alt x 100 feet indicates transmitted altitude of CAU or Mini-CAS includes 200-foot bias when transmitted during a coalition threat.

commands. The encounters were repeated, and the NO-TURN command obeyed, and the aircraft returned to parallel linear flights.

Case C is for two-aircraft encounters where the generation of a warning or advisory information is received with the aircraft ascending or descending. A LEVEL OFF or LIMIT VERTICAL SPEED command is utilized to stop the climb or descent when the protected altitude band, which possesses a Tau or minimum range threat, has been violated.

In the CAS, the LEVEL OFF command is generated by use of own altitude rate ( $\dot{h}$ ) and a comparison of altitude difference ( $\Delta h$ ), with the predicted coaltitude zone (figure 1-17). The logic within the CAS first examines the altitude threat by comparing transmitting aircraft altitude data relative to own aircraft altitude data. On the basis of this evaluation, the equipment classifies the altitude threat (figure 1-17) as follows:

1. Coaltitude minus  $\Delta h =$  zero to  $+800$  feet;  $>10,000$  feet
2. Advisory above/below minus  $\Delta h = +900$  to  $+3,300$  feet;
3. Predicted coaltitude only exists in the direction of change when own-altitude rate is greater than 500 ft/min.  $\Delta h = +900$  feet to  $+(\dot{h} \times 30)$ , where  $\dot{h}$  is own altitude rate in ft/sec.

Below 10,000 feet altitude the 800/900-foot boundary is reduced to 600/700 feet as seen in figure 1-18. When an intruder is within the predicted coaltitude zone boundary and within Tau zones 1 or 2, a LEVEL OFF command signal is generated.

The encounters were flown in the familiar figure-eight pattern with initial altitude separation of 3,000 feet. Air-Air-TACAN was used for vertical positioning with 3,000 feet equaling 0.49 nmi, 2,000 feet equaling 0.33 nmi, and aircraft were not permitted to penetrate to less than 500 feet. With the upper aircraft descending for the closest approach, the commands were obeyed to provide a safe separation. An example of the output data printout used in evaluating these encounters can be found in chapter 9, ALTITUDE BOUNDARY.

#### EXTENDED RANGE RESYNC.

The objective of the startup sync and range extension was to resync a long-range startup from the ground station.

STARTUP-RANGE EXTENSION. Without using special techniques, the startup range for acquiring initial fine synchronization is limited to approximately 48 nmi by the procedure described in ANTC 117 (except for special cases in which coarse alignment has been acquired from a nearby synchronized "third party"). Startup range is not limited by the RF power budget, which provides a nominal link, well over 100 nmi, but rather by the zero sync error reference time ( $t_s = 1,419.2 \mu s$  after start of slot) required to verify the range and resync pulses, and by round-trip propagation time, which imposes a logical restriction on startup range.

The CAS incorporates logic which extends startup range to approximately 80 nmi. In general, this is accomplished by having the CAU transmit early in time (prior to own BUM slot) if it fails to receive normal sync after coarse alignment to received epoch start triads. The donor (ground station or other airborne CAS) replies normally to the request and need not be aware of the situation. The requestor, however, can achieve fine sync if the reply arrives within its normal time slot. The early transmission, ahead of own BUM slot, allows more time for the requestor's range pulse to read the synchronized donor who must verify the entire pulse and transmit a sync reply before the end of slot time.

EXTENDED-RANGE RESYNC. The long-range startup and initial-sync acquisition process described above cannot be used to extend the resync range. (Serious range errors would occur if synchronized CAS transmitted early.) Therefore, a second method is used to extend the resync range of the CAU beyond the 80-nmi limit imposed by slot length (1,500  $\mu$ s) to approximately 150 nmi for ground-to-air operation. Air-to-air resync range remains at the 80-nmi limit.

The developmental model ground station incorporates extended-range resync logic which is compatible with that implemented in the CAU. In general, extended-range resync operates as follows:

1. The mode is used only by CAU-equipped aircraft above 20,000 feet, since line of sight otherwise limits its usefulness. The CAU must be in full HIERARCHY SYNC mode.
2. Message slots on F3 frequency (1615 MHz) are reserved for these aircraft. BUM and LIMITED SYNC mode aircraft always transmit on F1 (1600 MHz).
3. Two successive F3 slots per aircraft are used; one for normal range/altitude transmission, and the second for the ground resync reply. (This reduces the available F3 slots from 500 to 250 and total system slots to 1,750.)
4. The ground station replies normally to range pulses received within 80 nmi in the first F3 slot. It replies in the second F3 slot to range pulses received from 80 nmi to 200 nmi in the first F3 slot.
5. The airborne CAS normally does not track range to the ground station; it first looks for normal ground replies in the first F3 slot. If none occurs, it then looks for long-range ground resync in the second F3 slot.

An acceptance test was flown and results were reported in a letter to the program area leader. The letter report is included in appendix A. A flight summary is included in appendix B of all flights.

## CHAPTER 5

### FLIGHT TEST RESULTS AND CONCLUSIONS

#### INTRODUCTION.

The results reported in this final report were derived from laboratory and flight tests performed on a family of CAS equipment built by MDEC. The airborne units consisted of a Model 2000 CAU (full commercial version) and Mini-CAS (an updated version of the original general aviation Micro-CAS). In addition, a development model T/F CAS ground station based on ANTC 117 standards was used in the evaluation.

The flight test program was conducted in such a fashion, that comparative results with other candidate CAS systems could be made. Most flights were flown in the altitude-encoding mode, using available onboard aircraft ATCRBS encoding equipment. Where three-aircraft encounters were flown, altitude levels were simulated by an altitude switch box located at each CAS operator position. (Early flights were flown with separation of 400 feet, and pilots were instructed to obey commands.) It was found during these flights that the avoidance maneuvers and relative clearance separation were more than adequate. Encounters were flown flying lateral turn-in with altitude separations of 500 feet, and advisory and command warnings were more than adequate. Collision encounters involving either climbing or diving with initial separation outside the altitude boundaries, warning times were more than adequate. The flight test area chosen for communications range, reliability, synchronization, display reliability and warning time (obey maneuvers) was the Waterloo, VORTAC near Dover, Delaware. The area selected for altitude boundary, Tau warning zone, and lateral turn-in maneuver's, climb and dive, was in the vicinity of the Sea Isle VORTAC. All range, range rate, and warning time accuracy encounters were flown near NAFEC at Atlantic City, New Jersey, using phototheodolites, and EAIR (Instrumentation radar) for independent position measurement.

#### RF COMMUNICATIONS RANGE.

Communications range data were derived using the TACAN air-to-air measurement as a reference, and time-comparing it against the CAS for range errors. Range was recorded throughout the flight, with output starting and stopping times selected from the flight log sheets. Flights involving either CAU or Mini-CAS equipments or a combination of each, had sufficient communications range to alert for a Tau 2 warning at all collision encounter angles. When extrapolated to higher speed encounters above 10,000 feet involving two 600-knot aircraft, the power margins ranged between 3 and 6 dB for the CAU, for the flight patterns flown.

For flights involving the Mini-CAS below 10,000 feet, it also had sufficient communication range for a budget margin exceeding that required for Tau 2 warning.

#### RF (LINK) COMMUNICATION'S RELIABILITY.

The CAS, once having established adequate communication range, is required to have a high link reliability. This reliability is an indication of successful message transfers each epoch, between the CAS participants. The reliability categories were before Tau 2 (a point where initial range contact was started), Tau 2, Tau 1, Tau 1 and 2 (where combined link totals were computed), and overall.

Results for the link reliability are shown in table 5-1, with categories for each hardware type above 90 percent for all encounter angles flown. This analysis was made from 23 flights from the Com Mod series. For flights involving the Mini-CAS below 10,000 feet, it also had sufficient communication range for a budget margin exceeding that required for Tau 2 warning.

#### COMMUNICATIONS SYNCHRONIZATION RELIABILITY AND ACCURACY.

The CAS, in addition to having a high RF link reliability for message transfer each epoch, is required to initially obtain synchronization and process sync replies each epoch to participate in the T/F CAS community. The categories in table 5-2 are overall percentages for both ground and air communication chances transmitted and processed by the onboard CAS. Results shown for CAU's, of percentage of sync received/processed, were above 92 percent. A CAU requires a resync every 6 seconds to remain in sync, demoting to heirarchy No. 40 in the absence of resync in 4 minutes. The Mini-CAS's were flown both at short range (within CAS ground station communication range) and extended range over Waterloo, with an average value of 80-percent sync received/processed. The short-range flight value of 77 percent was attributed to the flightpath, where a portion of each pattern was flown over the CAS ground station. A 7-percent increase to 84 percent was noted on the overall value when the antenna angle was more favorable on the longer range flights. Accuracy mean difference values shown in table 5-2 were 0.0165  $\mu$ s for CAU and 0.0694  $\mu$ s average mean for Mini-CAS for the flights flown.

Both ground-to-air communication's reliability for synchronization and accuracy were more than adequate. Table 5-3 examines the individual breakdown for receptions of table 5-2.

#### RANGE AND RANGE RATE ACCURACY.

The CAS measurements were merged with smoothed tracker (Phototheodolite/EAIR) measurements to obtain range and range rate errors. Only the errors associated with converging flightpaths were considered in the analysis. Range separations between the two aircraft varied between 8 nmi and 0.2 nmi depending on the type of maneuver flown. Closing range rates varied between 0 knots and 440 knots, again depending on the maneuver. The range and range rate error samples taken, were from the Mini-CAS/Mini-CAS and CAU/CAU runs. Detailed screening was applied to each of the error samples.

TABLE 5-1. RF COMMUNICATIONS RELIABILITY AND RANGE

<u>Type of Equipment</u>	<u>Percent of Communication</u>				
	<u>Before Tau 2</u>	<u>Tau 2</u>	<u>Tau 1</u>	<u>Tau 1 and 2</u>	<u>Overall</u>
CAU vs. CAU	95.67	98.79	98.74	98.75	96.94 N = 22,420
Mini-CAS vs. Mini-CAS	96.00	98.96	99.79	99.34	98.79 N = 14,420
CAU vs. Mini-CAS	91.53	98.10	97.45	97.60	92.87 N = 22,711

Overall Communication's Range 30 nmi

- Power budget exceeded that required for Tau 2 warning.  
Additional power margins ranged between 3 and 6 dB for Com range extrapolated from 1,200 knots closing speed. (15.1 nmi for 40 sec Tau, 1.8 nmi R<sub>0</sub>)

Overall Communication's Range >20 nmi

- Power budget exceeded that required for Tau 2 warning, for communication range derived using 1,200 knots closing speed.

TABLE 5-2. COMMUNICATIONS SYNCHRONIZATION  
RELIABILITY AND ACCURACY

Type of Equipment	Synchronization		Accuracy-Difference Statistics in $\mu$ s					
	Number of Chances	Communications Processed	Percent Received	Maximum	Minimum	Range	Mean	Sigma
CAU vs. CAU	22,420	20,807	92.81	0.55	-0.35	0.70	0.0165	0.1007
Mini-CAS vs. Mini-CAS	2,578	1,984	76.96	0.45	-0.25	0.70	0.0460	0.1022
Waterloo vs. Mini-CAS	11,842	10,000	84.45	0.45	-0.35	0.80	0.0929	0.0865
CAU vs. Mini-CAS	22,711	19,676	86.64	0.75	-0.75	1.50	0.0542	0.1214

ACY - Flown over Atlantic City  
Waterloo - Approximately 50 nmi from ground station

ANTC 117 - Synchronization shall be accomplished with an accuracy of  $\pm 0.5 \mu$ s with respect to the synchronization donor, with a probability of 0.995.

TABLE 5-3. COMMUNICATIONS SYNCHRONIZATION RELIABILITY  
PERCENT RECEPTIONS FOR GROUND AND AIR

<u>Type of Equipment</u>	<u>Ground</u>			<u>Air</u>		
	<u>Chances</u>	<u>Receptions</u>	<u>Percent</u>	<u>Chances</u>	<u>Receptions</u>	<u>Percent</u>
CAU vs. CAU	14,494	13,538	93.40	7,926	7,269	91.71
Mini-CAS ACY	2,578	1,984	76.96	-	-	*
vs. Mini-CAS Waterloo	11,842	10,000	84.45	-	-	*
CAU vs. Mini-CAS	15,776	14,042	89.01	6,935	5,634	81.24

ACY - Flown over Atlantic City  
Waterloo - Approximately 50 nmi from CAS ground station

\* Mini-CAS was designed as a limited level 2 system and had no capability to transmit synchronization.

Statistical analyses indicated that range error did not vary significantly with range, closing range rate, or maneuver type. Overall estimates of Mini-CAS and CAU range error means and standard deviations are given in table 5-4. Analyses did indicate, however, a strong linear relationship between mean range rate error and closing range rate. The slopes of the estimated regression lines shown in figure 7-3 were approximately 3.5 percent for both the Mini-CAS and the CAU. This result is close to the 3 percent expected due to the design use of 200 feet per clock count instead of the true 194 feet. Estimates of mean range rate error for closing range rates from 0 to 700 knots are given in table 5-4. The range rate error standard deviations were found to be independent of maneuver or closing range rate. Overall estimates of the range rate error standard deviations are also given in table 5-4.

TABLE 5-4. RANGE AND RANGE RATE ERROR ESTIMATES

<u>Equipment Type</u>	<u>Range Error (nmi)</u>		<u>Range Rate Error (knots)</u>	
	<u>Mean</u>	<u>Std. Dev.</u>	<u>Mean</u>	<u>Std. Dev.</u>
Mini-CAS	-0.004	0.036	0 to 24*	13.5
CAU	0.019	0.032	-3 to 22*	14.9

\*As closing range rate increases from 0 to 700 knots (0 to 21 knots expected).

WARNING-TIME ACCURACIES.

Warning-time data were derived using phototheodolite and EAIR position data at the instant of time a first alarm occurred in a Tau zone. Tau 1 and Tau 2 warning-time statistics were compiled for both CAU and Mini-CAS equipment. The results are summarized in table 5-5.

A deviation from threshold Tau is the difference between the actual Tau (range divided by range rate) and the threshold Tau in seconds. A positive deviation means the warning is early, and a negative deviation means the warning is late. The mean deviations ( $\bar{X}$ ) in table 5-5 are in good agreement with those expected, i.e., 4.4 seconds late for CAU Tau 1, versus an expected 4.5 seconds late; and 1.6, 1.8, 1.6 seconds late versus 1.5 seconds late each for CAU Tau 2, Mini-CAS Tau 1, and Mini-CAS Tau 2. Note that the Tau 1 threshold for Mini-CAS has an offset of zero nmi and a reciprocal slope of 25 seconds as incorporated in the Mini-CAS equipment. Otherwise, the Tau thresholds are those specified in ANTC 117.

A percent deviation from threshold Tau indicates the percent of time to collision lost when a first alarm is late, and the percent of time gained when early. The percent deviation statistics given in table 5-5 were considered adequate for both Tau 2 and Tau 1 warning times.

TABLE 5-5. WARNING TIME ACCURACY ESTIMATES

CAS	Deviation from Threshold Tau in Sec.		Percent Deviation from Threshold Tau	
	<u>Tau 1</u>	<u>Tau 2</u>	<u>Tau 1</u>	<u>Tau 2</u>
CAS	$\bar{X} = -4.4$ $S = 2.0$ $N = 16$	$\bar{X} = -1.6$ $S = 2.8$ $N = 7$	$\bar{X} = -15.2$ $S = 7.0$ $N = 16$	$\bar{X} = -1.7$ $S = 3.0$ $N = 7$
CAU	$\bar{X} = -1.8$ $S = 1.7$ $N = 23$	$\bar{X} = -1.6$ $S = 3.1$ $N = 10$	$\bar{X} = -7.1$ $S = 6.7$ $N = 23$	$\bar{X} = -1.9$ $S = 3.5$ $N = 10$
Mini				

$\bar{X}$  = Mean, S = Standard Deviation, N = Sample Size

Threshold Tau = The value of Tau, in seconds, on the ANTC 117 Tau threat line at tracker range rate.

\* Exception - Threshold Tau 1 for the Mini-CAS determined from the Tau threat line incorporated in the equipment which has zero-nmi offset and reciprocal slope of 25 seconds.

$\triangle$  Expected  $\bar{X} = -4.5$  second, due to epoch phasing ( $\frac{3 \text{ sec}}{2}$ ) and 2 threats ( $\frac{3 \text{ sec}}{3 \text{ tries}}$ ).

$\triangle$  Expected  $\bar{X} = -1.5$  second, due to epoch phasing ( $\frac{3 \text{ sec}}{2}$ ).

Adequate Tau 1 warning-time accuracy is most important; for without it, there would be insufficient warning time to avoid a collision. In this respect, the results in table 5-5 imply (with 99-percent confidence) that at least 99.9 percent of CAU Tau 1 warnings are not later than -53 percent, and at least 99.9 percent of Mini-CAS warnings are not later than -39 percent. A 53 percent late warning for CAU Tau 1 corresponds to a loss of 16 out of 30 seconds, leaving 14 seconds to avoid a collision. A 39-percent late warning for Mini-CAS Tau 1 corresponds to a loss of 10 out of 25 seconds, leaving 15 seconds to avoid a collision.

#### DISPLAY RELIABILITY.

Display reliability measures the ability of the CAS system to provide an uninterrupted sequence of expected display advisories and commands to the pilot from the start of the threat at the Tau 2 zone to the end of the threat. All threats were treated as either Tau 2 advisories or Tau 1 commands.

Results for display reliability are shown in table 5-6. The smallest reliability for Tau 2 was 97.0 percent (Mini-CAS vs. CAU); the 3.0-percent loss being caused, primarily, by the slot-checking feature of the CAS equipment. For Tau 1, the least reliability was 99.0 percent (CAU vs. CAU); the 1.0-percent loss being caused by low CAS range rate measurements, and on a lesser scale by missed RF communications. All display reliabilities for the CAS equipment were well above 90.0 percent.

#### ALTITUDE ZONE BOUNDARY.

Flights were flown to determine the ability of each equipment type to correctly place the target in the proper altitude threat zone. Both CAU's and Mini-CAS's operated satisfactorily, with boundary zones either at the indicated level, or +100 foot higher, due primarily to clock phasing. Flight evaluation was carried out over 10 individual flights.

#### CONCLUSIONS.

From the results it was concluded that:

1. The MDEC CAS equipments perform the collision avoidance function as described in ANTC 117.
2. The Tau 2 communications range for both CAU and Mini-CAS was sufficient for encounters based on the range rates tested and extrapolated to 1,200 (knots).
3. There was satisfactory communications range for Tau 1 warnings.
4. The range and range rate accuracies were sufficient to establish an accurate track on the intruder.
5. The warning-time deviations from threshold Tau were considered adequate to avoid a collision under ideal conditions.

TABLE 5-6. DISPLAY RELIABILITY ESTIMATES

<u>Type of Equipment</u>	<u>Percent Display Reliability</u>		
	<u>Tau 2</u>	<u>Tau 1</u>	<u>Tau 1 and 2</u>
CAU vs. CAU	98.9 N = 908	99.0 N = 326	98.9 N = 1234
Mini-CAS vs. Mini-CAS	99.8 N = 539	99.5 N = 236	99.7 N = 775
Mini-CAS vs. CAU	97.0 N = 609	100 N = 130	97.5 N = 739

5-6

N = Total No. of displays in sample (one display each 3-second epoch)

Display Reliability =  $\frac{\text{Total No. Displays} - \text{No. Lost Displays}}{\text{Total No. Displays}}$

Lost Display (Tau 2) - No lights in Tau 2 zone when there should have been  
 Lost Display (Tau 1) - No command light in Tau 1 zone when there should have been

6. The display reliability gave a high reliability of correct threat information for pilot action.

7. The synchronization accuracy and reliability were more than adequate, with the exception of local flights using Mini-CAS versus Mini-CAS, where antenna shielding using the top antenna in proximity to the ground station presented problems.

## CHAPTER 6

### COMMUNICATIONS RANGE AND RELIABILITY AND SYNCHRONIZATION ACCURACY AND RELIABILITY

A total of 31 flights were selected for processing communication data for analysis. Out of these, only 25, or 80 percent, were eventually used in the analysis. The remaining flights were carefully reviewed and where instrumentation or accountable equipment malfunctions were present, these flights were not included in the analysis. The equipment configurations that were evaluated were as follows:

1. CAU vs. CAU (Full vs. Full)
2. Mini-CAS vs. Mini-CAS (Level 2 vs. Level 2), and
3. CAU vs. Mini-CAS (Full vs. Level 2).

The flight list breakdown (appendix B) indicates flight objectives and type of equipment and patterns employed during the test.

The main objective during this phase was to determine the range at which the required RF link parameters are established as a function of flight geometry. In addition the reliability and synchronization data message transfer between air-to-air and air-to-ground links were also investigated.

#### COMMUNICATION RANGE.

The following pattern was employed in the investigation of warning time and RF link between aircraft on a comparison basis with other CAS systems presently being evaluated. This pattern was developed by NAVAIRDEVCEEN and was carried forward in the NAFEC flight program (reference 11 and 12). The single-daisy figure-eight flight profile (figure 6-1) is unique, in that it maximizes the data collected for flight test hours flown.

In a two-aircraft encounter, one aircraft flies a daisy pattern, while the other flies a figure-eight pattern. The aircraft flying the daisy pattern commences flying from east of a TACAN ground station to west of the TACAN station. While inbound to the station from the east, his TACAN bearing is  $270^\circ$ , which is the course from magnetic north that he must fly to reach the station. After passing the TACAN station and continuing westward, his TACAN bearing is  $90^\circ$ . Upon reaching a predetermined distance west of the TACAN station, the pilot executes a  $180^\circ$  left turn to position the aircraft inbound on a radial displaced  $15^\circ$  from the previous radial traveled. His TACAN bearing is now  $75^\circ$ . After each traverse of the TACAN station, at the predetermined distance, the pilot executes a  $180^\circ$  left turn to assume a TACAN bearing displaced  $15^\circ$  from the previous one. This process continues for a total of 24 traverses of the TACAN station to form a daisy pattern. The aircraft flying the figure eight commences flying from west of the TACAN station to east of the station. While inbound to the station from the west, his TACAN bearing is  $90^\circ$ , which is the course he must fly to reach the TACAN station. After passing the TACAN station and continuing eastward, his TACAN bearing changes to  $270^\circ$ . Upon reaching a predetermined distance east of the station, the pilot executes a

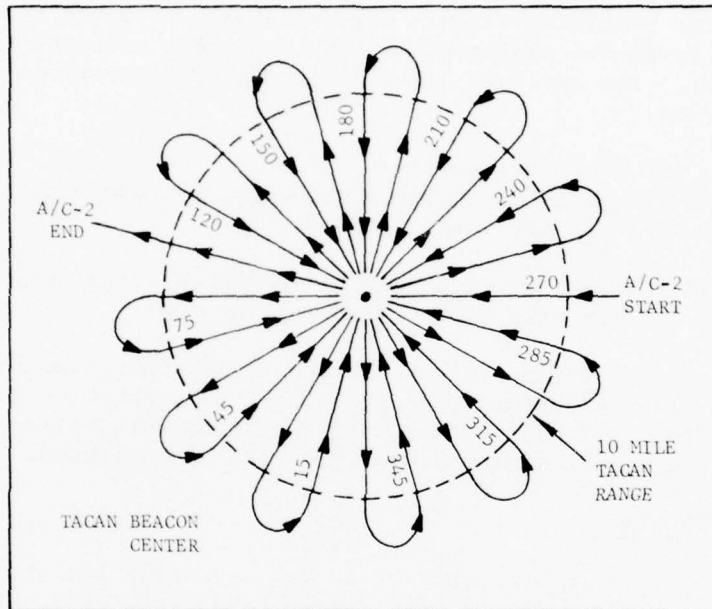
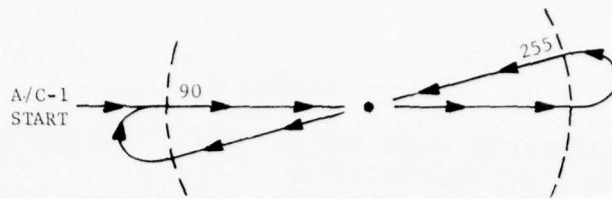

ENCOUNTER NUMBER	RADIALS FLOW		ANGLE BETWEEN RADIALS (DEG)
	A/C-1 (DEG)	A/C-2 (DEG)	
1	90	270	180
2	255	75	180
3	90	240	150
4	255	45	150
5	90	210	120
6	255	15	120
7	90	180	90
8	255	345	90
9	90	150	60
10	255	315	60
11	90	120	30
12	255	285	30
13	90	90	0

76-23-4-1

FIGURE 6-1. COMMUNICATIONS RELIABILITY. SINGLE DAISY OVER A FIGURE EIGHT

180° left turn to position the aircraft inbound on a radial displaced 15° from the previous radial traveled. His TACAN bearing is now 255°. Following this course inbound he traverses the TACAN station, whereupon his TACAN bearing changes to 75°. After reaching the predetermined distance outbound from the station, the pilot executes a 180° right turn and resumes his original eastward course with his TACAN reading 90°. Two traverses of the TACAN station constitute a figure eight. This pilot repeats the figure-eight pattern until the other pilot has completed his daisy pattern. The result, with proper selection of aircraft velocities and predetermined starting and turning distances, is a series of 24 collision encounters, meeting directly over the TACAN station, but displaced by 400 to 800 feet in altitude for safety of flight. The encounters occur in pairs, each pair being displaced 30° from the previous pair, with head-on encounters considered to be 180° encounters, and tail chases considered to be zero-degree encounters. The encounter angles (figure 6-1) are the angles between the TACAN radials flown by the two aircraft. The convention chosen for positive and negative encounter angles was as follows:

N377	Looks left to see	N376	-
N377	Looks right to see	N376	+
N42	Looks left to see	N377	-
N42	Looks right to see	N377	+

An encounter angle of -90° involving N377 and N376 would mean that the angle between the TACAN radial flown is 90° and that N377 would look left to see N376 when both are approaching the TACAN station.

The predetermined starting and turning distances were chosen as follows:

CAU-CAU	N377	250K	15nmi	+2.6	N42	370K	22.2 nmi	+3...	TACAN Slant Range
Mini-CAS-	N376	190K	12.7	+1.3	N377	150K	10	+1.3.....	TACAN Slant Range
Mini-CAS									
CAU-Mini-	N376	200K	9.2	+1.2	N377	150K	7	+1 .....	TACAN Slant Range
CAS									

The true airspeeds were selected in the same ratios as their starting distances from the TACAN station so that the aircraft arrival over the TACAN station would be coincident.

Typical airspeed versus mileage increments, as shown in table 6-1, were employed during the communications range, reliability, and synchronization flights. For example, the aircraft designated the control aircraft was occupied by a flight operation's specialist who coordinated the starting and stopping and patterning of each run. Any in-flight changes were coordinated by the specialist. After initial rendezvous and line up, the start of the run was accomplished by the specialist observing the DME fix distance, relative bearing of the remote mileage indicator (RMI) dial to the fix, and reciprocal information from the participating aircraft. When each aircraft was in position, a run start was initiated, and mileage bearing fix information was exchanged between aircraft during the run. Usually a distance callout was made every mile to enable each aircraft to adjust for wind and other factors.

TABLE 6-1. RATIOS OF STARTING DISTANCE  
FROM TACAN STATION

Control Aircraft Speed	Participating Aircraft Speeds (Knots)					
	150 Knots	190	230	250	265	275
	<u>Nautical Miles from DME</u>					
1	1.26	1.5	1.7	1.74	1.82	2.0
2	2.5	3.1	3.3	3.5	3.65	4.0
3	3.8	4.6	5.0	5.2	5.5	6.0
4	5.1	6.15	6.7	7.0	7.3	8.0
5	6.3	7.65	8.3	8.7	9.2	10.0
6	7.6	9.2	10.0	10.5	11.0	12.0
7	8.85	10.7	11.65	12.2	12.8	14.0
8	10.1	12.2	13.3	14.0	14.6	16.0
9	11.4	13.8	15.0	15.7	16.5	18.0
10	12.7	15.3	16.6	17.4	18.3	20.0
11	13.9	16.8	18.3	19.2	20.2	22.0
12	15.2	18.4	20.0	21.0	22.0	24.0
13	16.4	20.0	21.6	22.6	23.8	26.0
14	17.8	21.4	23.3	24.4	25.6	28.0
15	19.0	23.0	25.0	26.5	27.5	30.0

This procedure was maintained so as to effect a simultaneous crossover at the fixed station. Generally, the miss distances were of the order from 400 to 800 feet for most collision encounters.

When three aircraft were simultaneously flown in collision encounters, two of the aircraft flew figure-eight patterns displaced by 180° in space, while the third aircraft flew a daisy pattern. Thus the third aircraft generated a 360° daisy pattern with each of the other two aircraft, while they flew repeated 180° (head-on) encounters with each other. For these encounters between N42 and N377 or N376, the true airspeed ranged from 190 to 240 knots for N377 or N376 and up to 370 knots for N42.

It became apparent, that even with longer initial (head-on) starting distances, geometry limitations of the shallow angles (tail chases) would not allow sufficient pattern ranges to be established. For example, the communication range required for a tail chase involving a 300-knot aircraft by a 600-knot aircraft above 10,000 feet decreases to 5.13 nmi. With the geometry of flight chosen for optimum (minimum flight time), determination of communication range in encounter angle steps of 30°, these geometry limits had to be tolerated. Another example, with an initial start involving N376 at 12.7 nmi and N377 at 10 nmi, the maximum measured range was 22.7 nmi. This was more than adequate for the head-on, but with the pattern limitation, this diluted down to 2.8 nmi for the tail-chase encounter. This problem was partially solved by adding attenuation in the RF line (table 2-1,) which increased the geometric limits.

Since the most severe angle was the tail chase, a separate flight was flown for each class of equipment with initial separation on a radial run of 10 nmi. With the added attenuation in the line (6 dB) for aircraft involved in the encounters, this had the effect of doubling the geometric limit as far as the parameter of signal strength was concerned. With 3 dB added in the lines, it had an effect of increasing the geometric limit to only one half as much. A separate flight, number 54, was flown with 3 dB attenuations. The encounters without the daisy-pattern limitation, commenced with a 10-nmi tail-chase separation; with the 3 dB, this increased the geometric limit to 15 nmi, and was more than sufficient for a tail-chase flight. Another separate flight, No. 32 using N42, used starting distances of 10 nmi, but with the 6-dB doubling effect, the geometric limit was increased to 20 nmi. Although problems with the onboard data collection prevented the analysis to be carried out to the maximum range. However, this problem was not present in the case involving N42 and N377. The limits using aircraft N42, starting at 22.3 nmi and N377 at 15-nmi air-to-air separation with the starting encounter, were more than adequate when looking at the tail-chase range of 7.2 nmi.

In instances where two aircraft are flying above 10,000 feet at 600 knots each, the maximum communication range required is 15.1 nmi for a 40-second Tau 2, 1.8-nmi  $R_0$  (range offset from zero closest approach point), range equals zero.

The Mini-CAS versus Mini-CAS, or level 2 equipment, was intended for use in general aviation aircraft. The cable length additions on the upper antenna only increased the link by approximately 3 dB in the N376 and N377 aircraft. When N42 was involved, link range was doubled to +6 dB. For Mini-CAS, the initial starting distances were more than sufficient for communication range. In the case of the tailchase, with an aircraft traveling at 150 knots encountering an aircraft of 400 knots below 10,000 feet, the communication range for a Tau 2 indicator reduces to 4.57 nmi for adequate RF link warning. An additional tailchase flight was flown to exercise this angle.

The geometric limitations for the communication range flights are plotted in figures 6-2, 6-3, and 6-4 for N377 versus N42, N377 versus N376 (CAU), and N377 versus N376 for a (Mini-CAS) equipment. These were used as a guide in determining whether the communication ranges for the various flights fell within the expected geometric limitations. Although, one would not expect the communication range to exceed the theoretical geometrical limitations, this did occur occasionally, due to imperfections in the flight course flown, primarily from wind or one pilot turning sooner or later to correct for a previous encounter with a large miss distance. Usually, this problem was minimized by assigning one aircraft to call out the mileage increments to the fixed point. Where the communication range was limited by geometry or aircraft turning to get on course, the encounter start times (epochs) were manually recorded in each aircraft. These epoch times were used to align the program tape for a similar range comparison. Otherwise the ranges are representative of the communication ranges to be expected for the given encounter angle. Usually each single daisy flight had two ranges for each encounter angle. Differences in range of two-to-one, are due to variations in crab angle flown

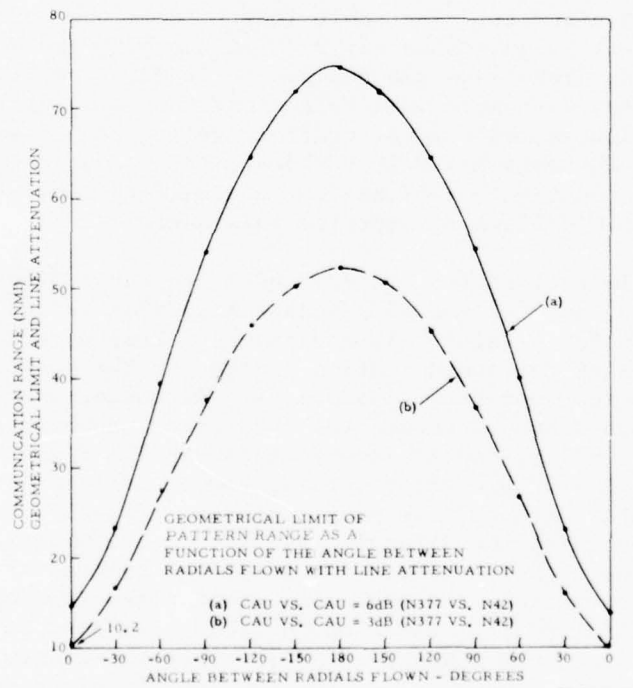
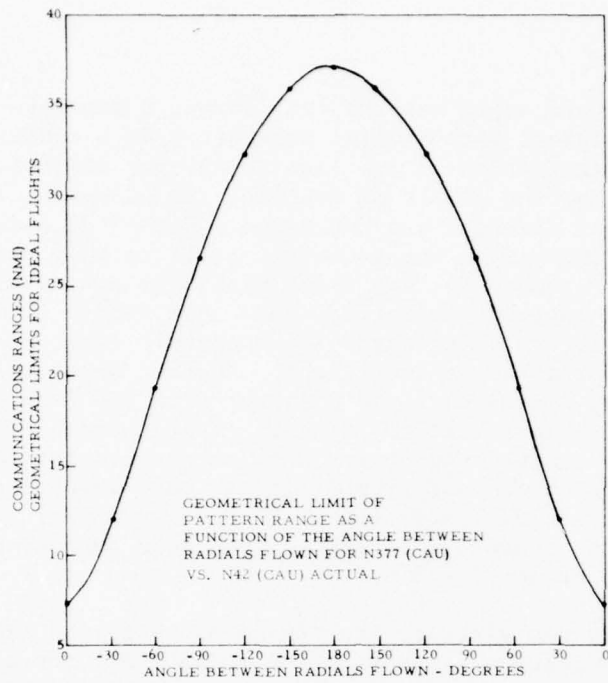
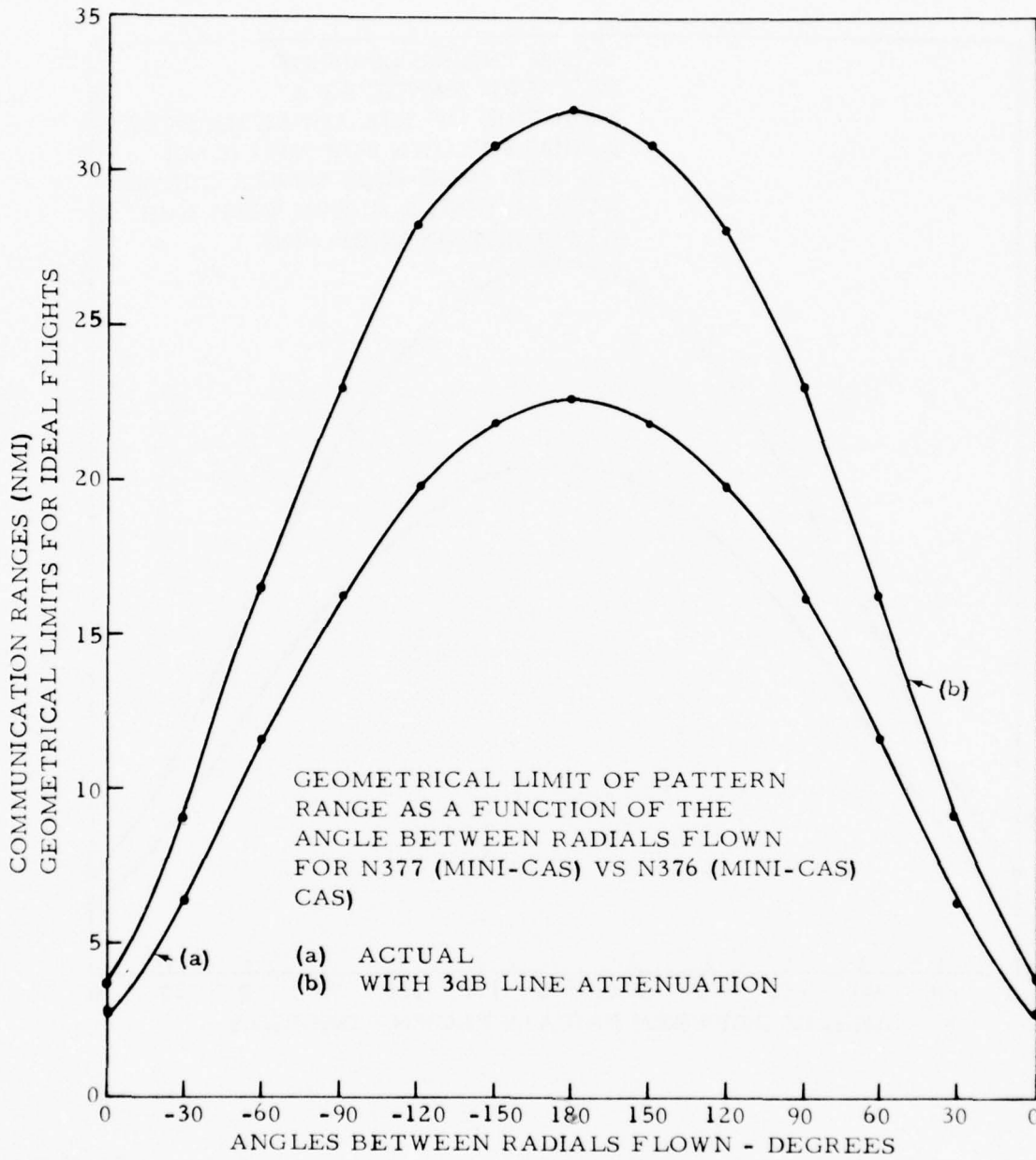
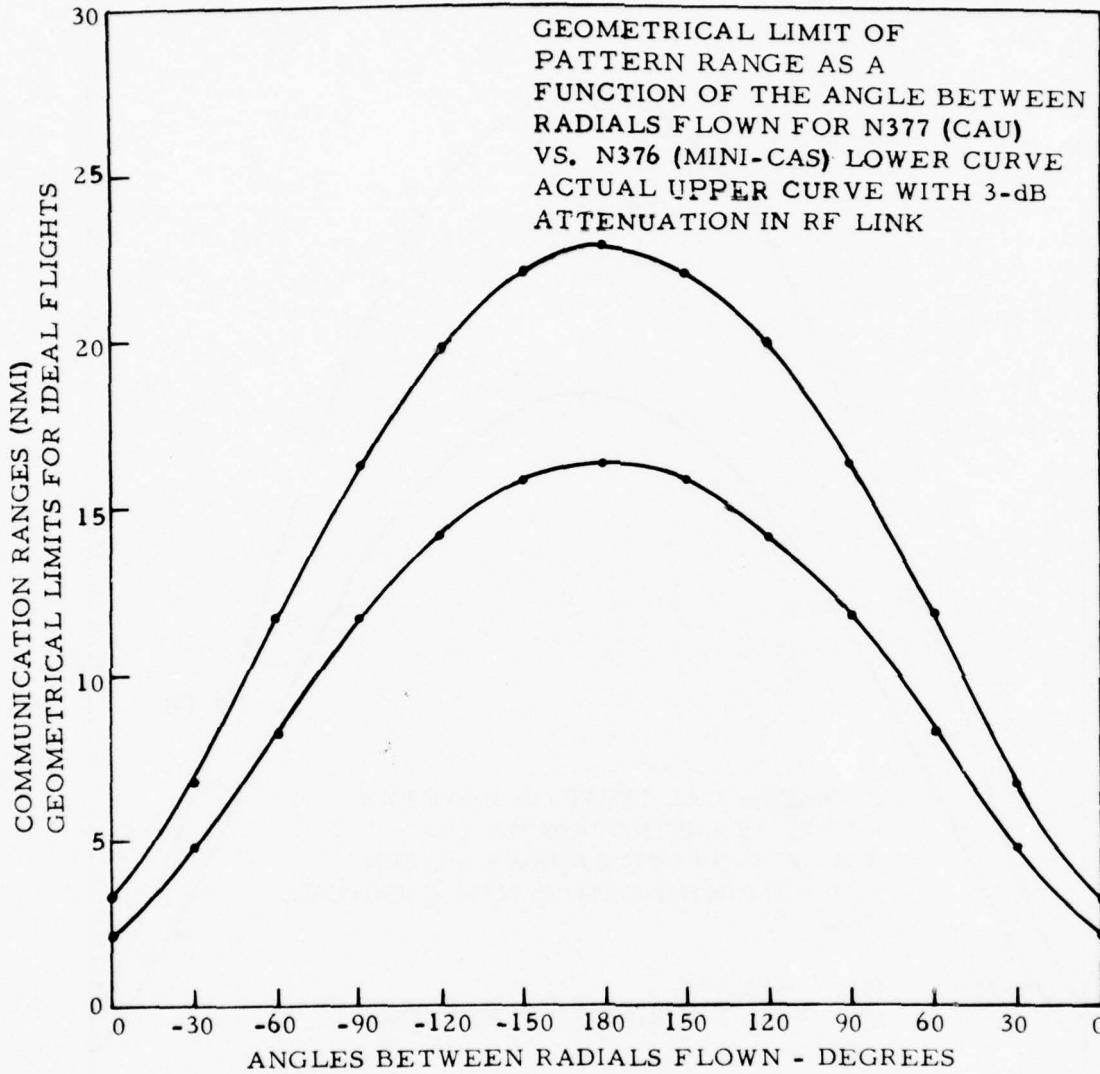

FIGURE 6-2. GEOMETRIC LIMITATIONS, N377 VS. N42



76-23-6-3

FIGURE 6-3. GEOMETRIC LIMITATIONS, N377 VS. N376



76-23-6-4

FIGURE 6-4. GEOMETRIC LIMITATIONS, N377 VS. N376

against the TACAN radial going in the opposite direction. While all points are plotted, the communication range curves are drawn through the approximate mean of the data points for each encounter.

The communication ranges shown in figures 6-2, 6-3, and 6-4 are plotted individually, where one aircraft is acquiring and tracking the other after a starting point was initiated by the flight test coordinator.

On screening of information, the CAU measured range, range rate, altitude, and accepted hierarchy synchronization information continuously throughout the encounter. However, the Mini-CAS was screened from delivering range rate information until the 16-nmi air-to-air separation point was reached. Although each equipment was allowed to communicate throughout the total flight, data collection was stopped at each turning point and then restarted after initial aircraft line up.

In examining the individual flights in detail, the results indicate what communication range margins can be computed from known data to extrapolate for maximum 1,000- and 1,200-knot closing rates.

Figure 6-5 is a graph depicting communication range as a function of the angle between TACAN radials (encounter angles) for flight 57 on September 28, 1975. The altitude separation ranged between 600 and 800 feet, with N42 at 11,700 feet and N377 at 11,000 feet. This flight was a test of the CAU equipments above 10,000 feet, with moderately high closing rates, with initial encounter head-on being 560 knots. Viewing the points on the graph contained in the  $\pm 120^\circ$  angle, it is seen that 14 values had a mean value of 29.9 nmi. Two range points at 12 nmi were deleted from the computation, due to a late tape recorder start, which failed to acquire the true range figure. In comparing this mean value with the head-on encounter of a closing rate of 1,200 knots, where the required communication range would be 15.1 nmi, an overall 6-dB margin exists; and where the true aircraft speed averaged 560 knots during the encounter, the communication range required was only 8.02 nmi, the margin was 11.4 dB. As indicated, for the speeds flown the power margins were even greater. Inspecting the tail-chase mean of 5.5 nmi, this margin was close to 9 dB. The run was started within the geometrical limit, with N42 at 5.7 nmi at epoch 3240 overtaking N377. True aircraft speeds were 360 knots for N42 and 200 knots and N377. The first Tau 2 warning occurred at epoch 3282 at 3.1 nmi. The difference of 42 epochs (126 seconds) before initial Tau 2 warning was given provided a margin of what is indicative in the power budget figure. Examining the individual tracks, it becomes apparent that good correlation of data can be extracted from this flight. As for the flight versus the geometric limitations, all data were well within the limits of flight variation.

Flights 49 and 50 (figure 6-6) on September 2 and 3, 1975, are communication range values obtained in flight testing two Mini-CAS equipments below 10,000 feet. The altitude separation for the encounter angles flown were 500 feet. Aircraft N377 was at 8,100 feet and N376 was at 8,600 feet. Initial closing speed of 400 knots was used in testing the Mini-CAS, which is a general

COMMUNICATIONS RANGE AS A  
 FUNCTION OF THE ANGLE  
 BETWEEN RADIALS FLOWN  
 FLIGHT 57, SEPT. 28, 1975  
 N377 BELOW N42

DATA SAMPLE: 1  
 22 COLLISION ENCOUNTERS

× TRACK OF N377 BY N42  
 ○ TRACK OF N42 BY N377

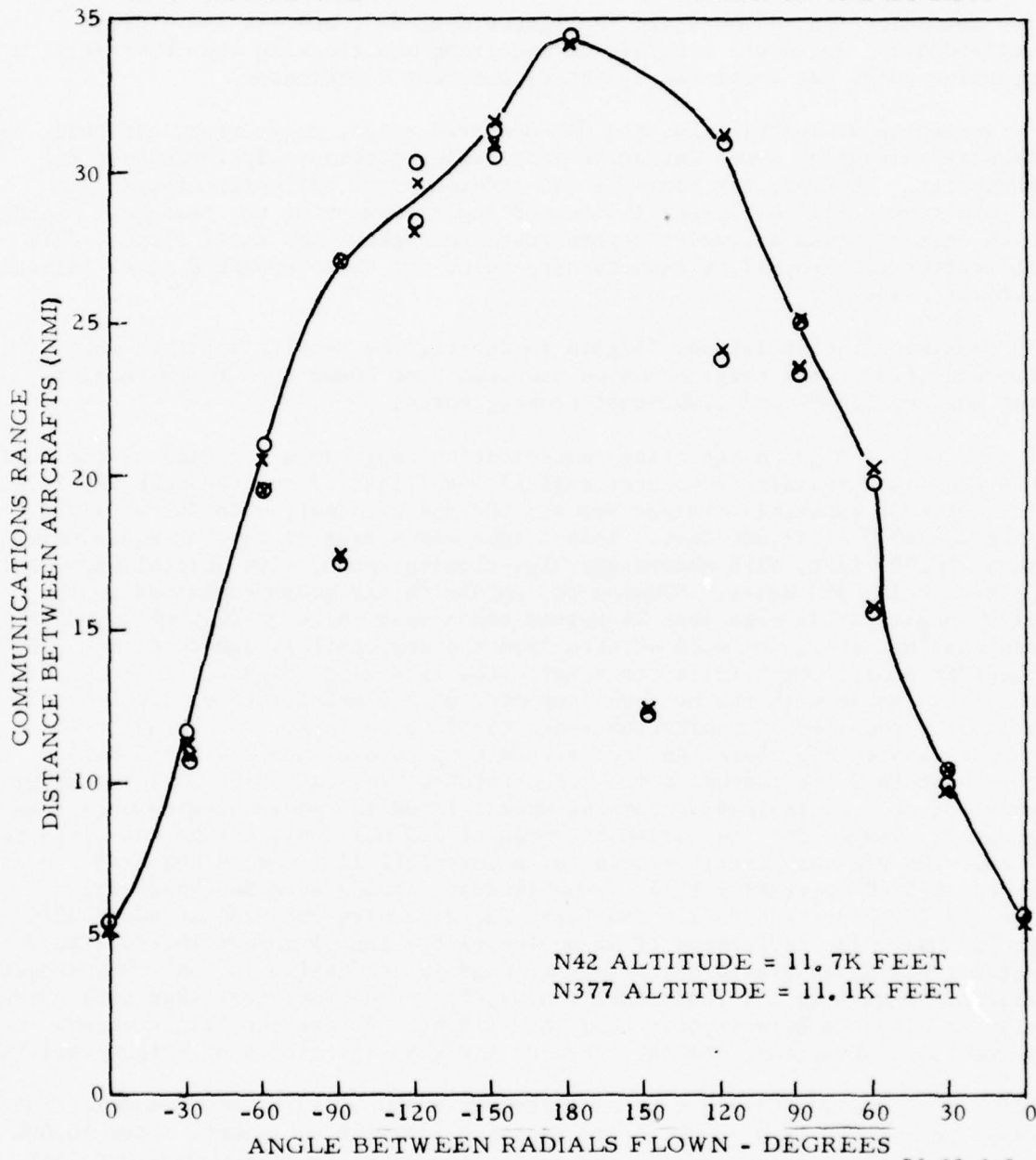

Figure 6-5. COMMUNICATIONS RANGE FLIGHTS, N377 (CAU) VS. N42 (CAU)

COMMUNICATIONS RANGE  
 AS A FUNCTION OF THE ANGLE  
 BETWEEN RADIALS FLOWN  
 FLIGHT 49, SEPT. 2, 1975  
 FLIGHT 50, SEPT. 3, 1975

DATA SAMPLE:  
 21 COLLISION ENCOUNTERS

× TRACK OF N377 BY N376  
 ○ TRACK OF N376 BY N377

N377 ALTITUDE = 8.1K  
 N376 ALTITUDE = 8.6K

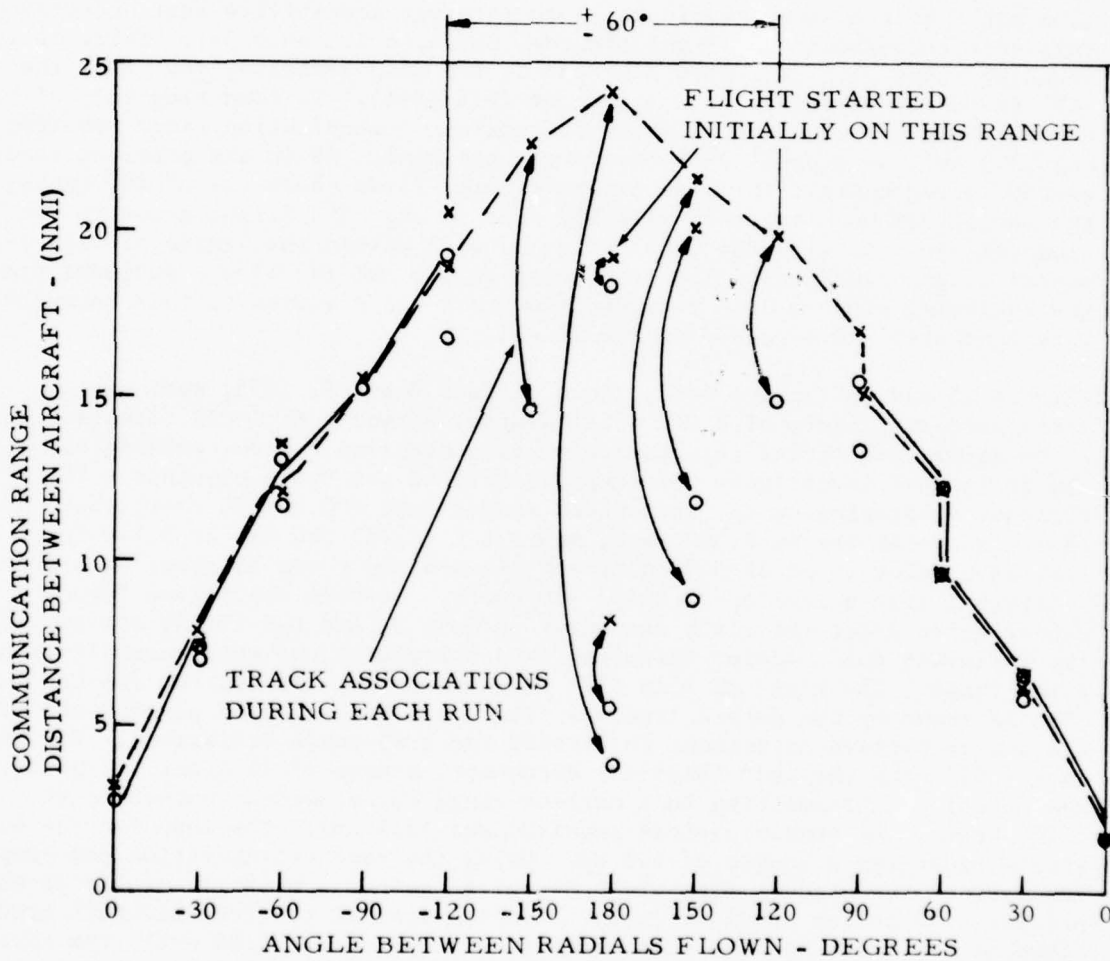

76-23-6-6

FIGURE 6-6. COMMUNICATIONS RANGE FLIGHTS, N377 (MINI-CAS) VS. N376 (MINI-CAS)

aviation type of equipment. The track data from N376 - (X - dashed line) to N377 (O - solid line) indicate that range dropout was occurring in N377 during the initial head-on and thru-encounter angles  $\pm 60^\circ$  either side. The ground rules established in analyzing the range data were that two consecutive range verifications should be established before a range communication track is initiated.

Mini-CAS 1 had a history of communication difficulties at the extreme ranges (above 20 nmi). In most instances, a range message was received, but it failed to receive the second, thereby negating the start. This problem was not due to the aircraft; Mini-CAS 1 was transferred during the evaluation to the other aircraft, and it exhibited similar range startup difficulties. One explanation might be the slow deterioration in receiver sensitivity that occurred on this unit throughout the flight program, as shown in table 3-1. Using corresponding range data from N376 Mini-CAS 2, the data straddling  $\pm 60^\circ$  from the  $180^\circ$  (head-on) encounter show a mean of 20.8 (N=8). In comparing this with a closing rate of 1,000 knots, where the maximum communication range required was 12.9 nmi, an overall 4-dB margin was apparent. As in the previous case, extrapolating against the true aircraft speed flown (head-on) of 400 knots, the margin was much greater, slightly over 10 dB. The flight geometry was flown as planned, with the data collected well within the limits of experimental flight variation. The data point at 8.1 nmi (N376) was excluded from the analysis, since a late recorder run start was executed on this encounter. This encounter was repeated in the flight.

Flights 15 and 16 (figure 6-7), flown on June 3 and 4, 1975, were single-daisy pattern flights of a CAU (full system) versus a Mini-CAS (limited level 2) to gather additional information on communication ranges, warning times, and to further investigate the compatibility of the two equipments. The altitude separation on the encounters ranged from 400 to 500 feet, where A/C 1 (N377) Mini-CAS was at 8,500 feet, and A/C 2 (N376) CAU was at 8,100 feet. Initial closing speed of 340 knots was planned and flown in order to simulate a terminal area encounter of below 400 knots. Weather conditions forced cancellation after the sixth encounter on June 3, and the flight was completed the following day. Again, there was good correlation between communication track range. The Mini-CAS 2 in N377 is shown by the circle, and the CAU 2 in N376 is shown by the dashed line -X. The lower range points at  $+60^\circ$  and  $-150^\circ$  are due to pattern adjustment to correct for crab angle deviations. For the data  $\pm 60^\circ$  from the  $180^\circ$  (head-on) encounter, a mean of 15.5 nmi (12 points was noted). Extrapolating to a maximum range for a head-on encounter at 1,000 knots, the communications required was 12.9 nmi. The mean for the  $60^\circ$  window indicated a margin of 1.8 dB. Using the same extrapolation and comparing against the head-on mean of 16.35 nmi (4 points), a margin of 2.2 dB was present. As in the previous case, comparing against the true aircraft speed flown of 340 knots head-on (communications required was 5.58 nmi), the margin was 9 dB. No attempt was made to analyze the smaller angle encounters, since range was limited by the geometry of the daisy pattern flown. Although in reviewing the tail chase, the ranges recorded were more than twice the 1.8-nmi advisory, which would indicate a margin ranging from 3 to 6 dB.

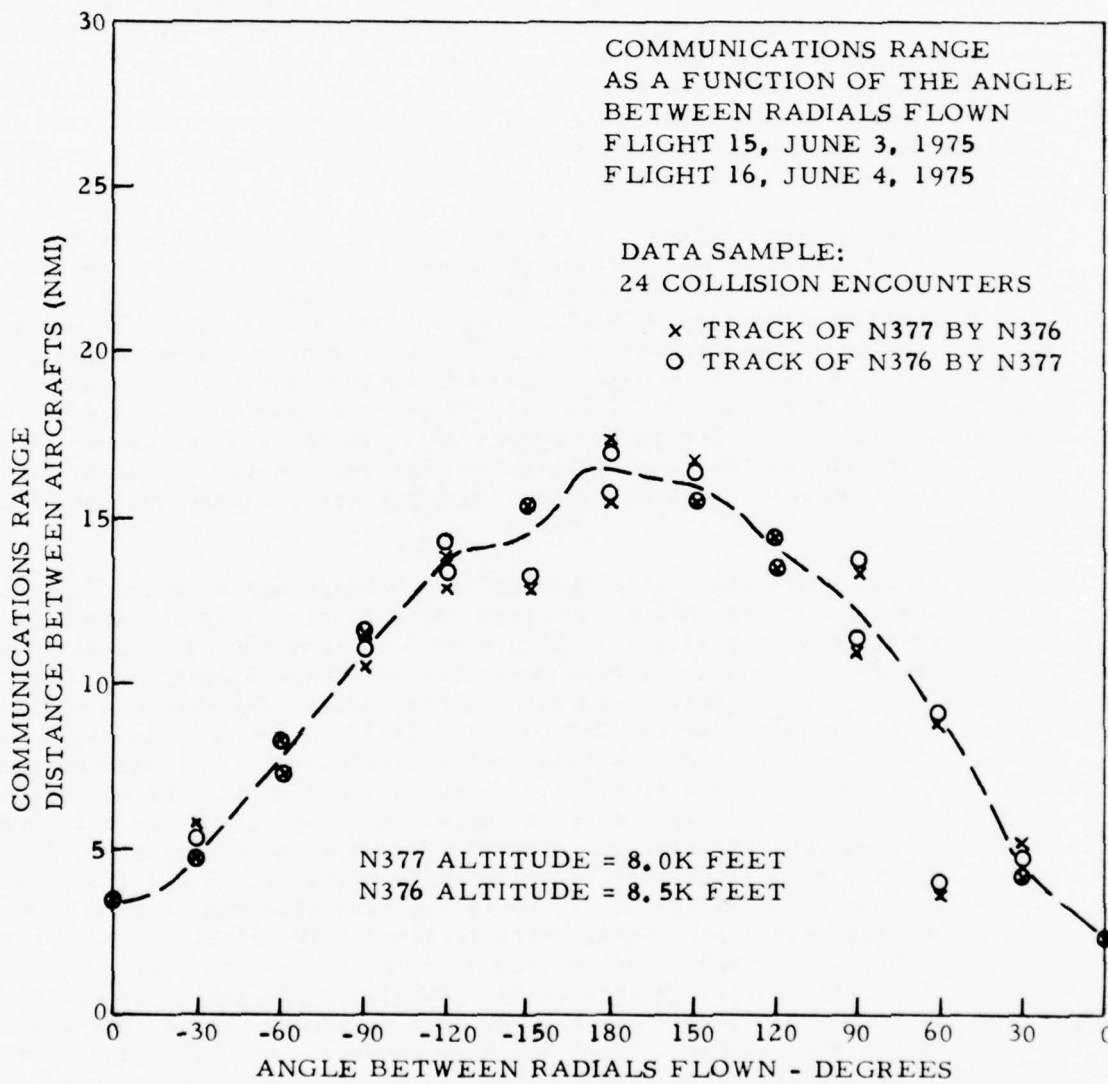

76-23-6-7

FIGURE 6-7. COMMUNICATIONS RANGE FLIGHTS, N377 (MINI-CAS 2) VS. N376 (CAU 2)

Figure 6-8 depicts the double-daisy pattern for flights 10 thru 14 flown on May 15, 20, 29, and June 2, 1975, respectively. The first 19 encounters, starting with the initial head-on, were flown at longer ranges in order to establish a range figure of merit between a CAU and a Mini-CAS. The aircraft flew at a 400-foot altitude separation with A/C 2 (N376) at 10,000 feet and A/C 1 (N377) at 9,600 feet. This test, in addition to being an equipment comparison mix, also exercised the "low-altitude" (9,600 feet) and "high-altitude" (9,800 feet) cutoff of the threat logic altitude bands. By design, coalatitude bands above 9,800 feet extend to cover  $\pm 800$  feet around the base-altitude-indicated difference of two aircraft. At 9,600 feet and below, the coalatitude band extends some  $\pm 600$  feet around base aircraft altitude. The 200 feet is overlapped when transitioning from one logic threat zone to the other and are shown in figures 1-18 and 1-19.

Concentrating on the blocked inset of figure 6-8, which represents the 19 encounters, a histogram was plotted as shown in figure 6-9. In the histogram, a range value extends from a low of 21.5 nmi to a high of 36.6 nmi, with a grouped coordinate mean of 30.9 nmi. Extrapolating data to a 1,200-knot encounter, the margin is greater than 6 dB. When comparing the head-on range values of 35.4 and 35.0 nmi, the margin is further increased to 7.5 dB. As can be seen from the total plot of figure 6-8, close correspondence exists between the two initial tracks for the 72 encounters. In the smaller encounter angles, as in the tailchase, the range figures are not representative and do not reflect the true communication range, since pattern geometry was the limiting factor.

Another flight where the initial communication range was exceeded in order to investigate the forward antenna location was a double-daisy pattern of a CAU-versus-CAU (full system flight). Figure 6-10, flight 20, 23, and 26, flown on June 16, 20, and 24, 1975, were communication range flights to gather reliability, synchronization, and warning-time data. The test was modified to a "upper antenna only" for the CAU on A/C 1 (N377). The antenna toggle switch was placed in the "lock-up" position, which provided for transmission and reception of data messages to A/C 1 on upper antenna only. The objective was to determine whether a single antenna (upper) had any effect on link range, reliability, and synchronization. The equipments were full systems, flying above 10k feet, with aircraft separated by 400 feet, with A/C 1 (N377) at 10,600 feet and A/C 2 (N376) at 11,000 feet. Examining figure 6-10 blocked inset, and histogram figure 6-11, which represents the first 19 encounters, or a 90° segment, range values extend from 32.9 nmi to 21.7 nmi, with a mean of 26.1 nmi (for 38 points). Both aircraft ranges are plotted in the histogram. As before, extrapolating against a 1,200-knot encounter, the margin was greater than 6 dB. Comparing with the head-on values of 32.9 and 32.5 nmi, the margin is 6.6 dB. This double-daisy flight was completed in three flying periods. Again, geometry limited the smaller angle communication ranges, especially near the tail-chase angle, which was cancelled.

A Mini-CAS-versus-Mini-CAS double-daisy flight (figure 6-12, 70 encounters) was flown over three flight periods, starting with flight 19, June 11, 1975, where photoinstrumentation was used for data recording, and ending on flight 43 and 48, August 14 and 29, 1975, using a tape interface magnetic

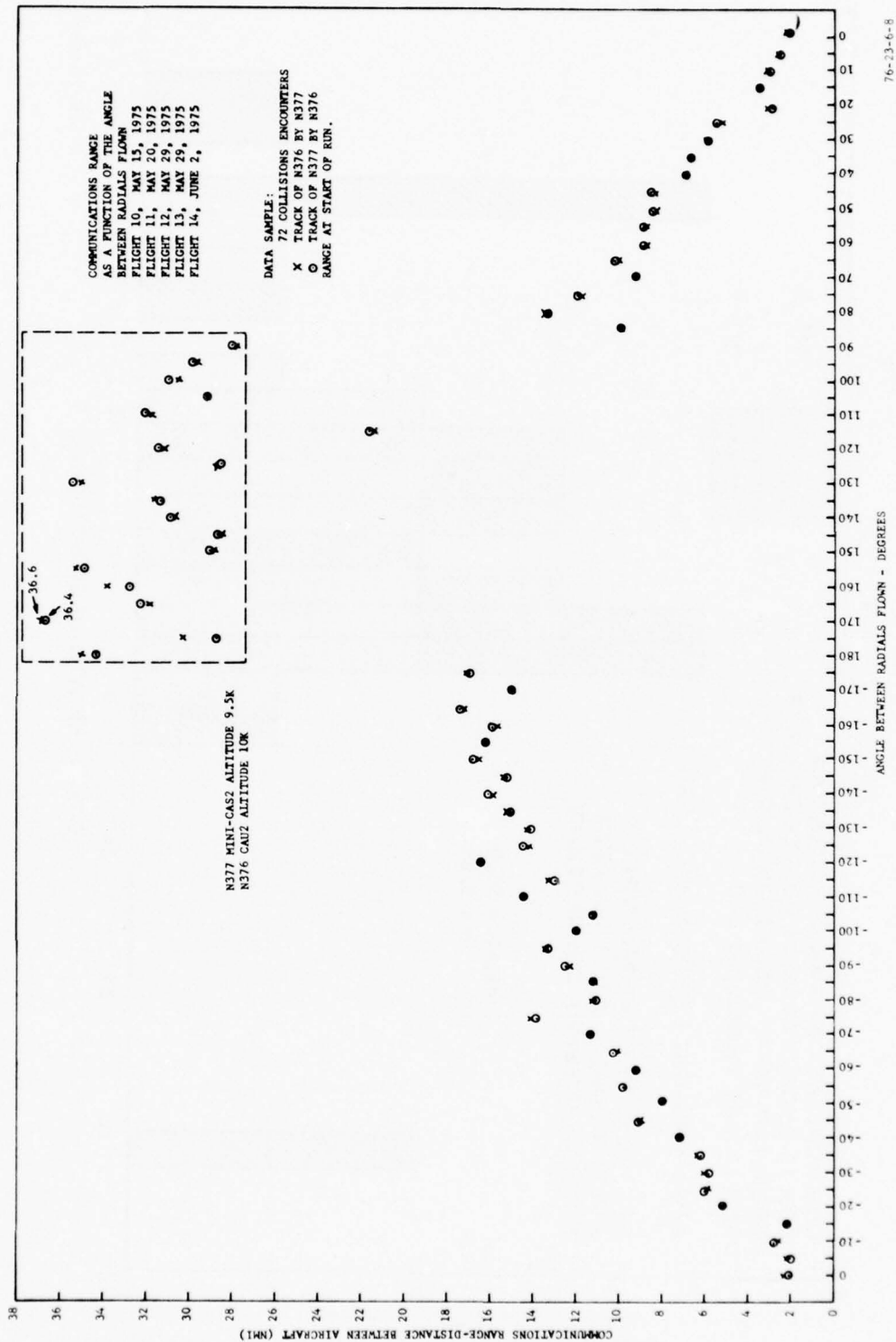

BEST AVAILABLE COPY

FIGURE 6-8. COMMUNICATIONS RANGE FLIGHTS, 10, 11, 12, 13, AND 14

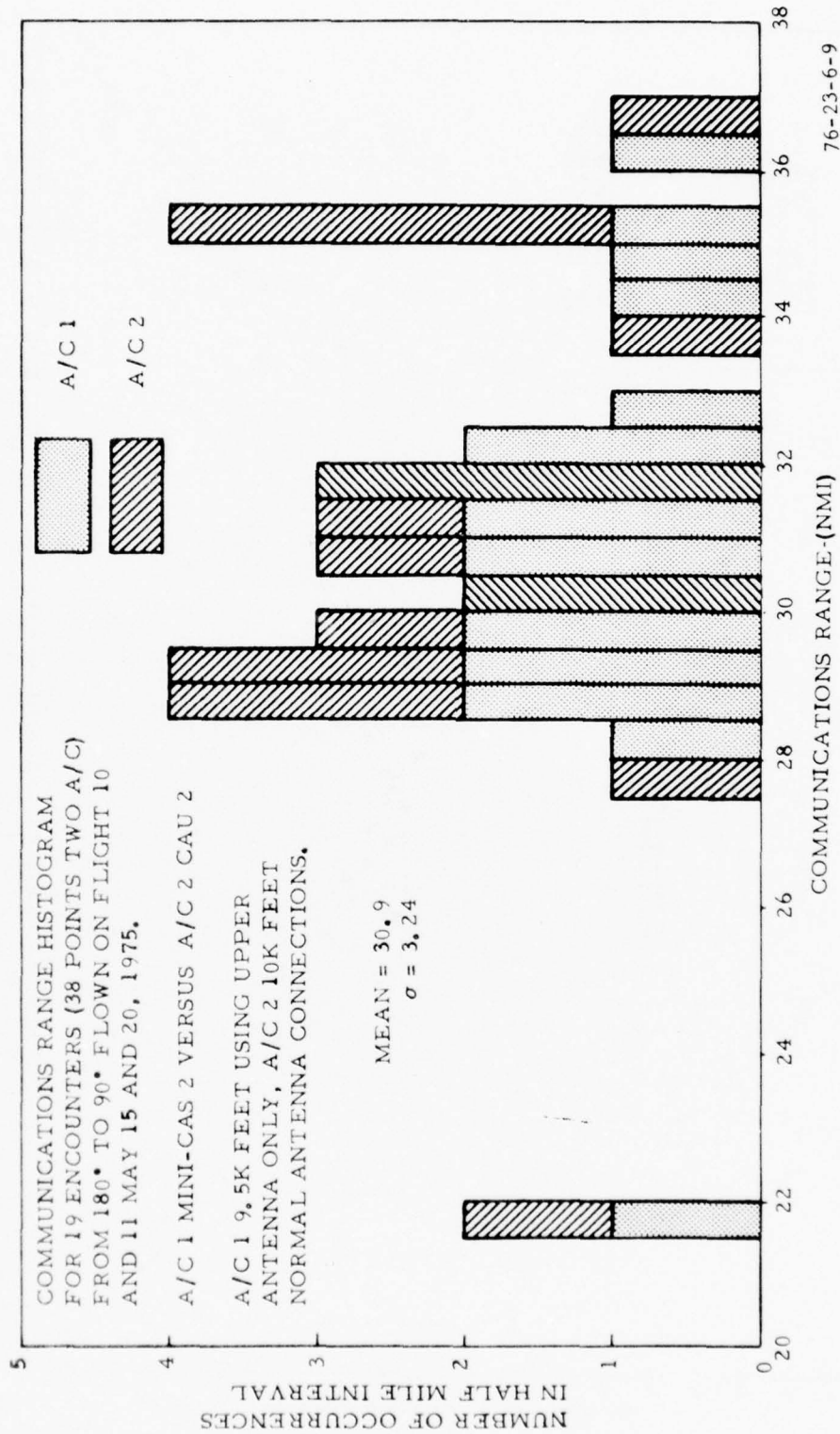

FIGURE 6-9. COMMUNICATIONS RANGE FLIGHTS 10 AND 11

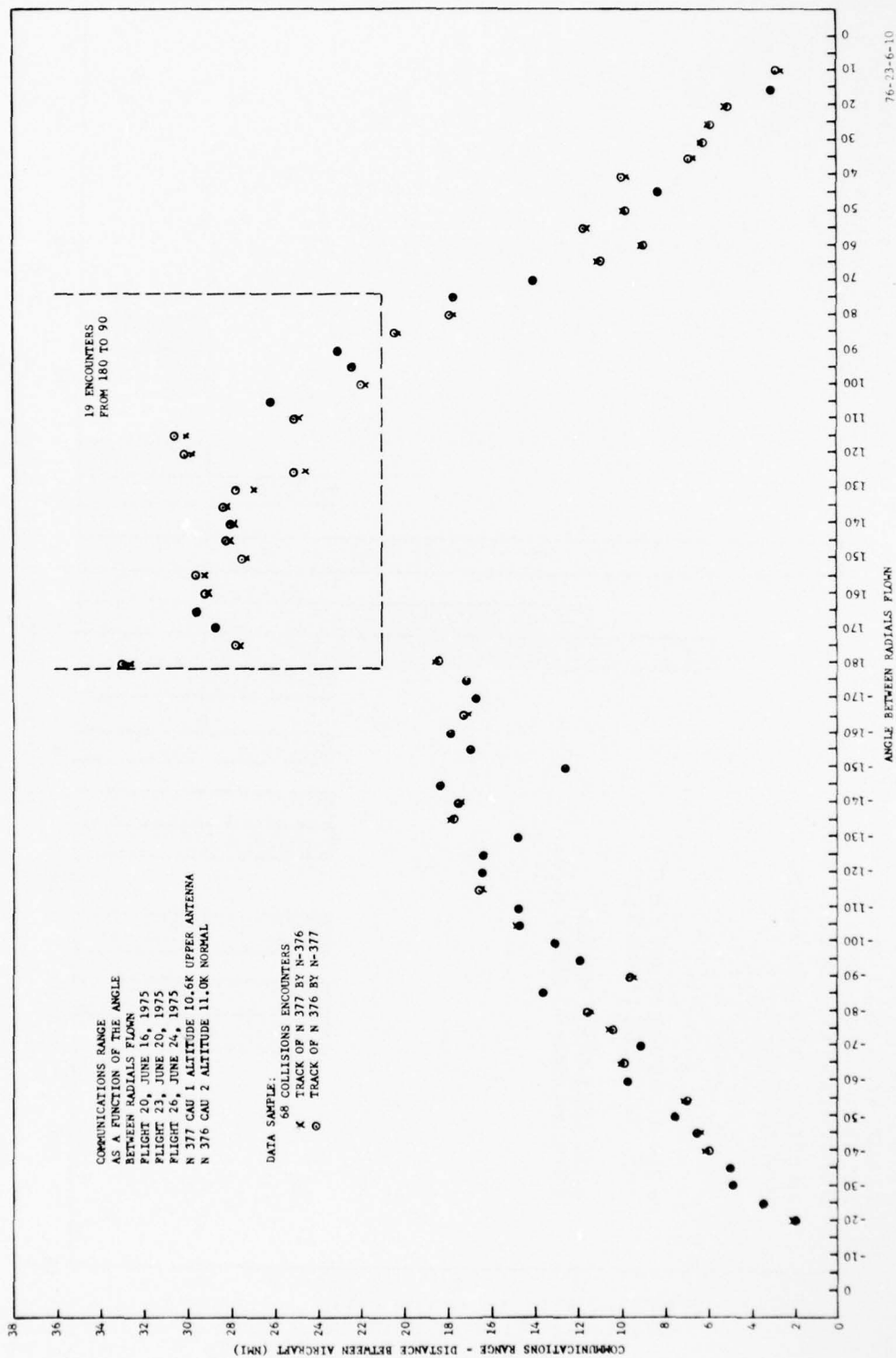

FIGURE 6-10. COMMUNICATIONS RANGE FLIGHTS, 20, 23, AND 26

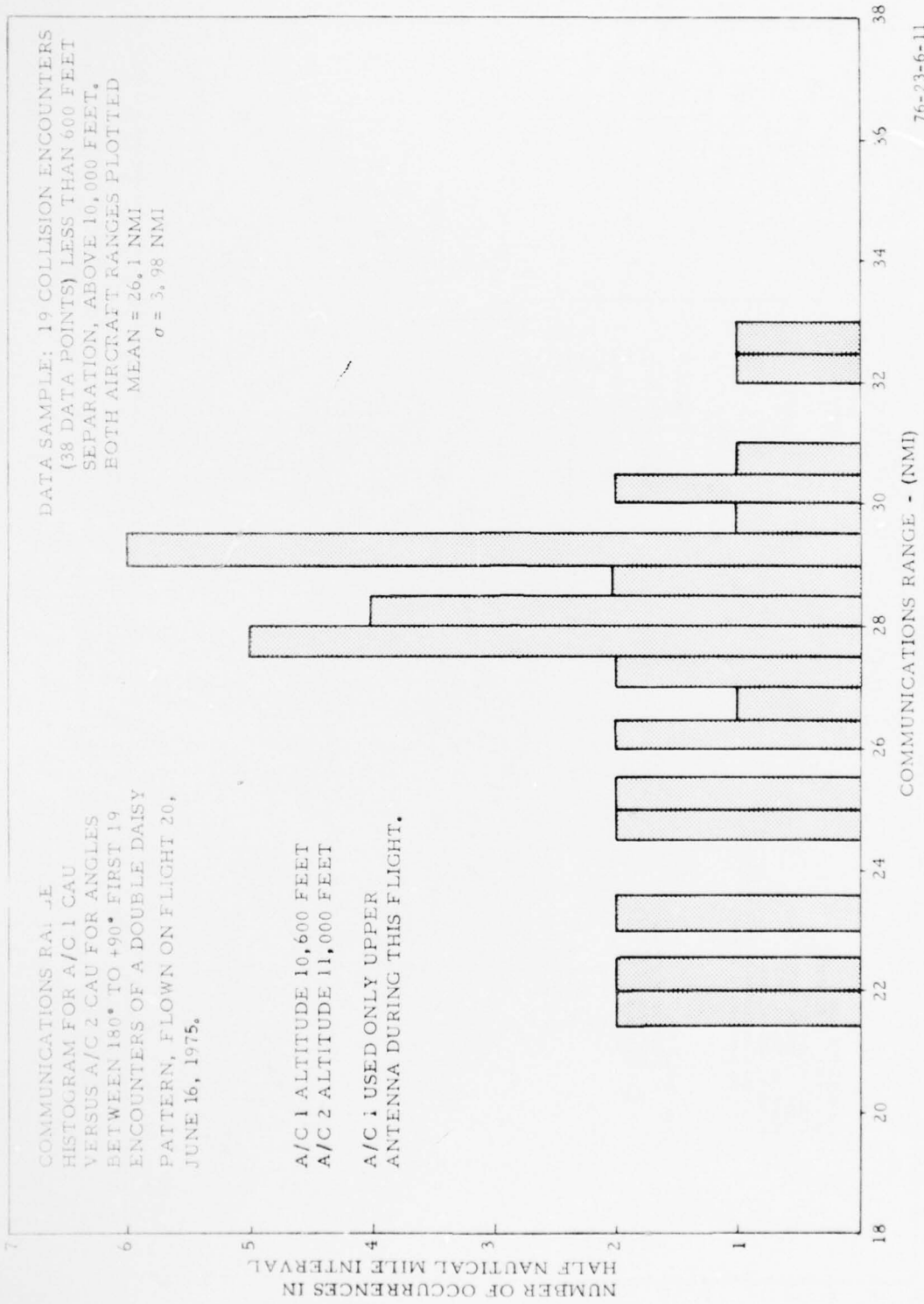

FIGURE 6-11. COMMUNICATIONS RANGE FLIGHT 20

BEST AVAILABLE COPY

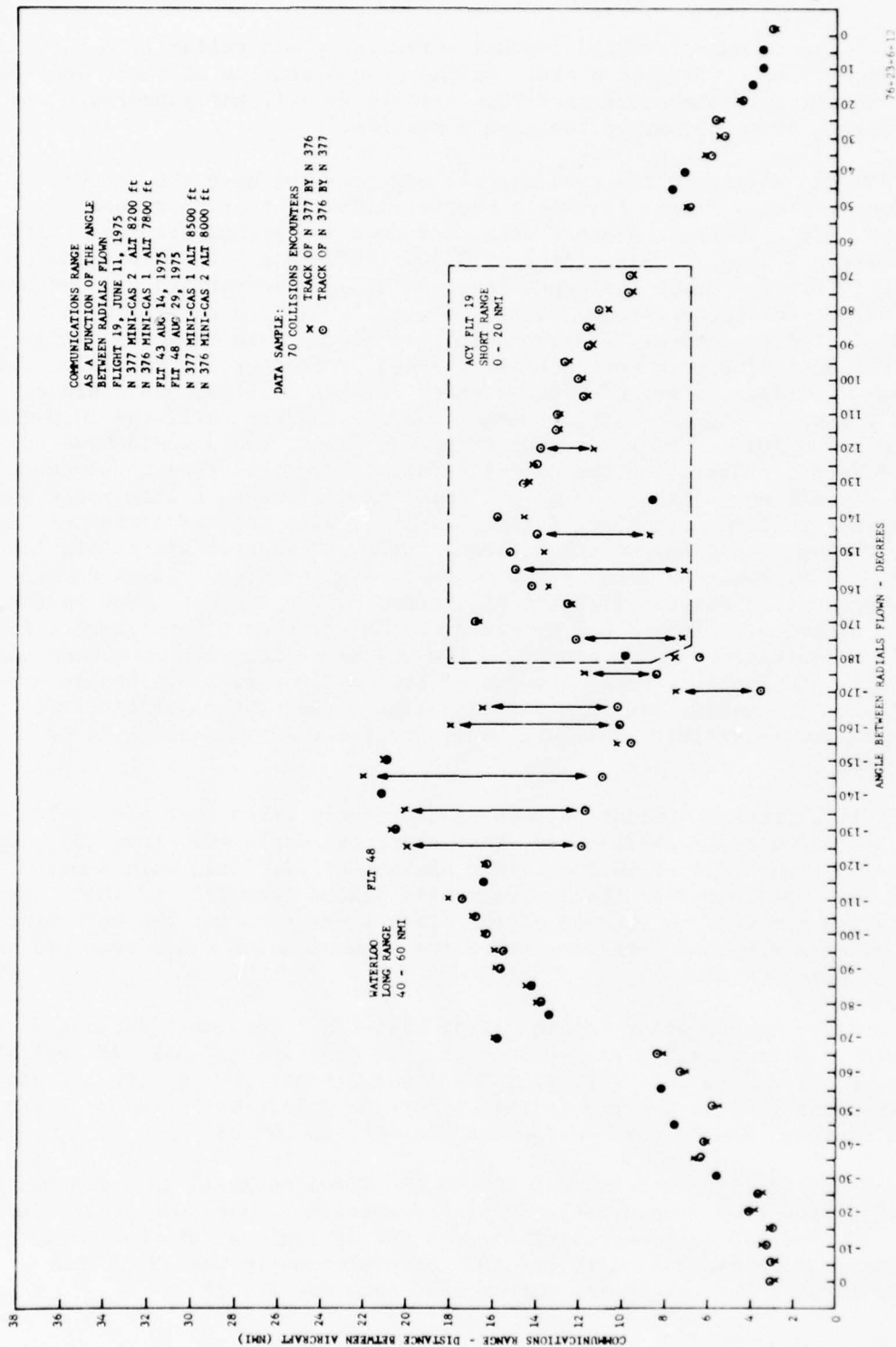

FIGURE 6-12. COMMUNICATIONS RANGE FLIGHTS 19, 43, AND 48

recorder. The flights recorded communication range and reliability information in addition to synchronization from the CAS ground station at short and long range. Short-range distances were from zero to 20 nmi, and long-range distances were from 40 to 60 nmi to the ground station.

A Mini-CAS can only accept a sync signal, and does not have the capability of sync transmission. Flight 19, was a short-range flight of 23 encounters ( $180^\circ$  thru  $+70^\circ$ ) where crossovers were made over the ground station. Altitude levels were A/C 1 (N377) Mini-CAS 2 at 8,500 feet and A/C 2 (N376) Mini-CAS 1 at 8,000 feet. The track correspondence was acceptable through all encounters, except during the encounter angles of  $175^\circ$ ,  $155^\circ$ ,  $145^\circ$ , and  $120^\circ$ , when A/C 2 Mini-CAS failed to achieve hard communication at the same range as A/C 1 Mini-CAS. Reviewing processed data at the  $155^\circ$  encounter, it was found that one range verification was present at epoch 1004 at 13.8 nmi and again at epoch 1008, (12.6 nmi). Communication contact was not resumed until the 10.0-nmi range on epoch 1027. For the encounter speeds flown, Tau 2 would have occurred at the 6.24 nmi. Reviewing the data listing, it was seen that no advisory or command signals were lost on this run. Similar instances of late range verification occurred on flight 48, August 29, 1975, with the completion of the daisy. During flight 43, where shallower angle and shorter air-to-air link runs were made, Mini-CAS 1 exhibited no range difficulties. It is normal during range verification between aircraft at extreme ranges to miss a few epochs; however, close in or near Tau 2 presents another problem. For example, for a missing communication of two epochs in the OMS aircraft, with encounter speeds approaching 600 knots, a range dropout of 1.0 nmi is possible. Should one aircraft be maneuvering and shielding its signal, and the other aircraft carrying a low-sensitivity receiver, adequate Tau 2 advisories could be jeopardized.

Figure 6-12 depicts a similar pattern as previously shown in figure 6-10 and 6-11. Analyzing A/C 2 (N376) only, from encounter angle  $-90^\circ$  thru  $165^\circ$ , shows a variation from a low of 10.2 nmi to a maximum of 22.0 nmi, with a mean of 17.8 nmi. Deleted from the analysis were angles from  $170^\circ$  to  $180^\circ$ , due to compensation for wind on the end of the flight. Margins for the encounter angles using a 600-knot baseline, where the communication range required was 8.46 nmi, were 6.4 dB.

The laboratory measurements (table 3-1 of Mini-CAS 1 receiver) indicated a slow rate of deterioration as the test program progressed. Also in reviewing appendix C, it can be seen that Mini-CAS 1 had a history of altitude logic problems possibly contributing to its failure to detect an intruder of the extreme ranges. The RF link design for Mini-CAS is 20 nmi.

Flights 8 and 41 (figure 6-13) CAU versus CAU flown on April 23 and August 12, 1975, also show good communication range correlation. Altitude separation between 600 and 800 feet exercised the coalitude logic point above 10,000 feet. The communication range mean at the  $180^\circ$  encounter angle was 19.75 nmi. For this flight, the margin for the head-on case was 2.3 dB.

COMMUNICATIONS RANGE  
AS A FUNCTION OF THE ANGLE  
BETWEEN RADIALS FLOWN  
FLIGHT 8, APRIL 23, 1975  
FLIGHT 41, AUG. 12, 1975

UPPER ANTENNA ON N377 FOR FLIGHT 8  
N377 ALT = 11,000 - 10,600  
376 ALT = 10,600 - 10,100

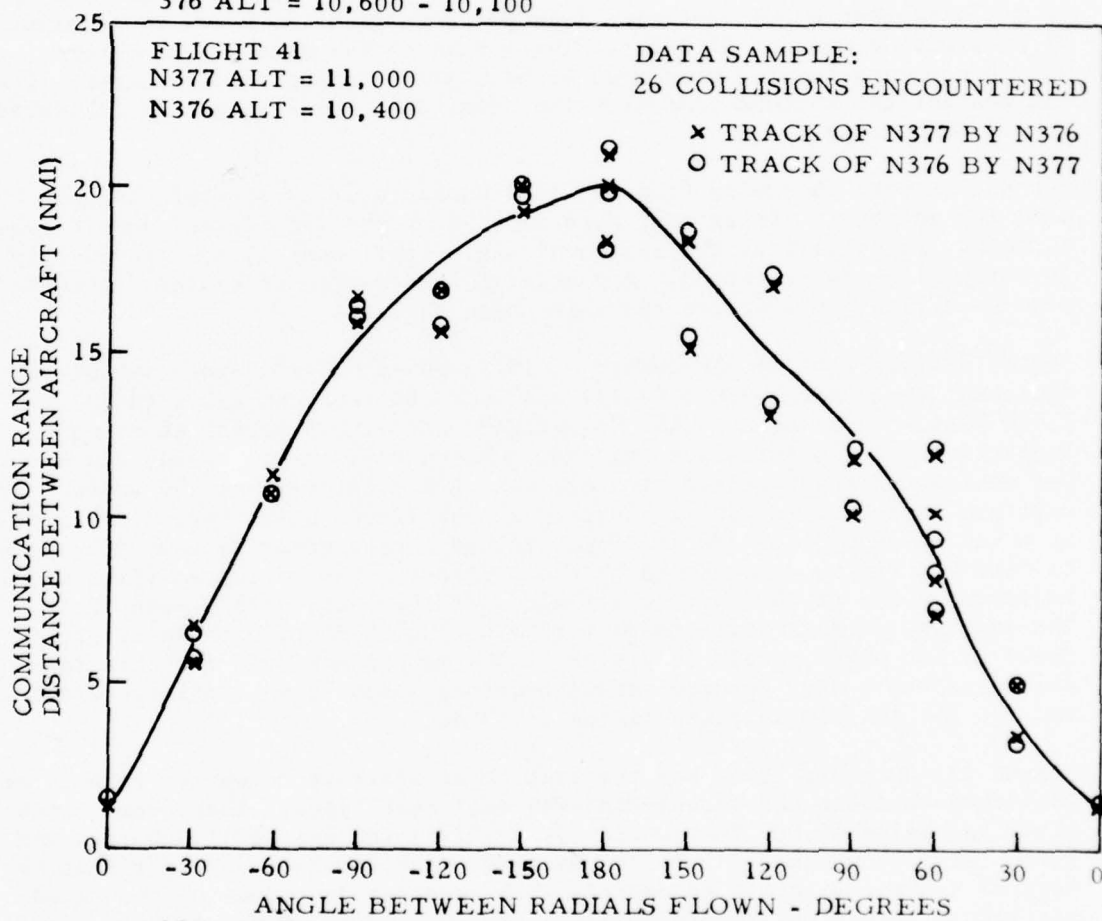

76-23-6-13

FIGURE 6-13. COMMUNICATIONS RANGE FLIGHTS 8 AND 41

Figure 6-14 (Flight 31 on July 19, 1975) was the initial three-aircraft encounter flight flown. Each aircraft was positioned as shown in figure 4-5 (three-A/C head-on/90°). One exception was that A/C 2 flew a standard daisy against A/C 1 and A/C 3, with all encountering a crossover at the same time. True aircraft altitudes were A/C 3 (N42) at 11,000 feet, A/C 1 (N377) at 9,000 feet, and A/C 2 (N376) at 7,000 feet. An ATRCBS altitude simulator box was used only on A/C 2 (8,500 feet simulated altitude) to allow it to threaten on A/C 1, which flew its true altitude. This flight being the maiden flight for NAFEC magnetic tape interface, serial number 2 on A/C 3, which experienced problems with redundant range and other data messages, and made the data unusable. The tape data from A/C 1 were used in the analysis and plotted in figure 6-14. All data from A/C 2, which used photoinstrumentation were usable, and were essentially repeats of results obtained previously. The range data of A/C 1 on the histogram shows variation from a low range of 30.4 nmi to a maximum of 41 nmi, with a mean of 37.2 nmi. The spread of the data is, as before, mainly due to compensation for wind made by each pilot during the encounter. Comparing against the maximum communication required a +8-dB margin is indicated for the 12 encounters.

Antenna pattern shadowing from the rear surfaces of an aircraft is well known. With the geometric limits that were imposed by the single- and double-daisy patterns, especially at the shallower angle (tail chase), additional flight investigation was performed. A special flight series of radial "overtake" runs were flown to exercise the tail-chase angle.

Figure 6-15 (flight 54, September 8, 1975) was a Mini-CAS-versus-Mini-CAS equipment encounter. A/C 1 (N377) was at 7,000 feet and A/C 2 (N376) at 8,000 feet. This was a radial "overtake" run, with aircraft starting respectively at 18 nmi and 6 nmi from a known fix. A/C 1 speed, 250 knots, was designated the overtake aircraft with A/C 2 maintaining 150 knots. The overtake crossover encounter occurred at the 12-nmi point beyond the fix, making it a run of 30 nmi for A/C 1. Range values were greater in some instances, due to wind and timing encountered by the aircraft. The histogram (figure 6-15) indicates a low of 10.5 nmi to a maximum of 15.5 nmi, with a mean of 12.8 nmi. The required communication range for below 10,000 feet, with an aircraft speed of 500 knots, would be 7.4 nmi. The margin achieved for this tail-chase encounter was 6 dB. For the actual overtake speed flown (difference A/C 1 vs. A/C 2), the margin extrapolates to 13 dB.

Flight 32, July 21, 1975, was the last three aircraft encounter flights with a tail-chase between CAU-versus-Mini-CAS equipment types. These were encounters above and below 10,000 feet where A/C 1 (N377) CAU was at 11,000 feet and 2,000 feet below was A/C 2 (N376) Mini-CAS at 9,000 feet. This flight was part of a three-aircraft encounter, with recorder data loss on the third aircraft. (A/C 3 was recording A/C 1, and 2, and A/C 2 and 1 were recording each other.) The recorded communication ranges were 15.5, 10, and 10.1 nmi with no range variation between aircraft. A mean value of 11.9 nmi for the three encounters indicate sufficient margin for the tail chase.

DATA POINTS: 12 COLLISION  
ENCOUNTERS, TRUE  
ALTITUDE SEPARATION  
2,000 FEET, A/C 1 RANGES  
ARE PLOTTED ONLY.

MEAN = 37.2 NMI  
 $\sigma = 3.16$  NMI

COMMUNICATIONS RANGE HISTOGRAM  
FOR HEAD ON ENCOUNTER FLOWN ON  
FLIGHT 31, JULY 19, 1975. THIS WAS  
A THREE AIRCRAFT ENCOUNTER, DATA  
FOR A/C 3 (N-42) AT 11,000 FEET VS  
A/C 1 (N377) AT 9,000 FEET.

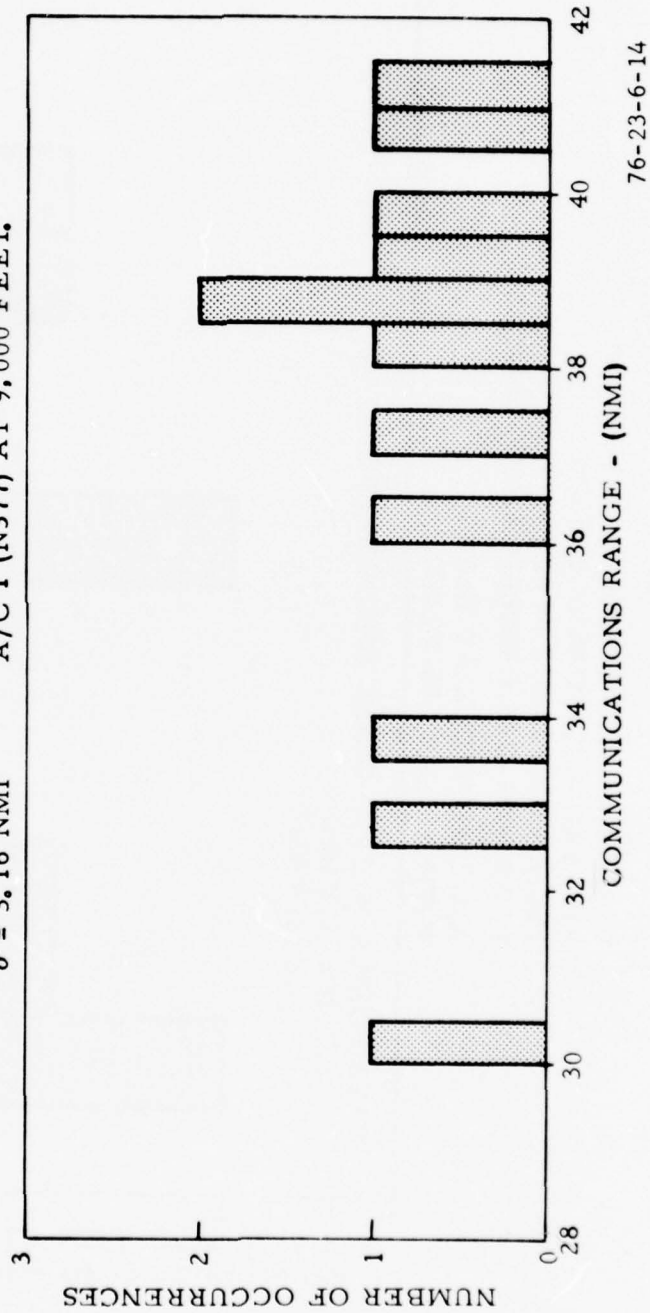

76-23-6-14

FIGURE 6-14. COMMUNICATIONS RANGE FLIGHT 31

COMMUNICATIONS RANGE HISTOGRAM  
 FOR TAIL-CHASE ENCOUNTERS  
 FLOWN ON FLIGHT 54 SEPT. 8, 1975  
 A/C 1 MINI-CAS 1 VERSUS A/C 2 MINI-CAS 2  
 A/C 1 ALTITUDE AT 7K FEET  
 WITH A/C 2 AT 8K FEET

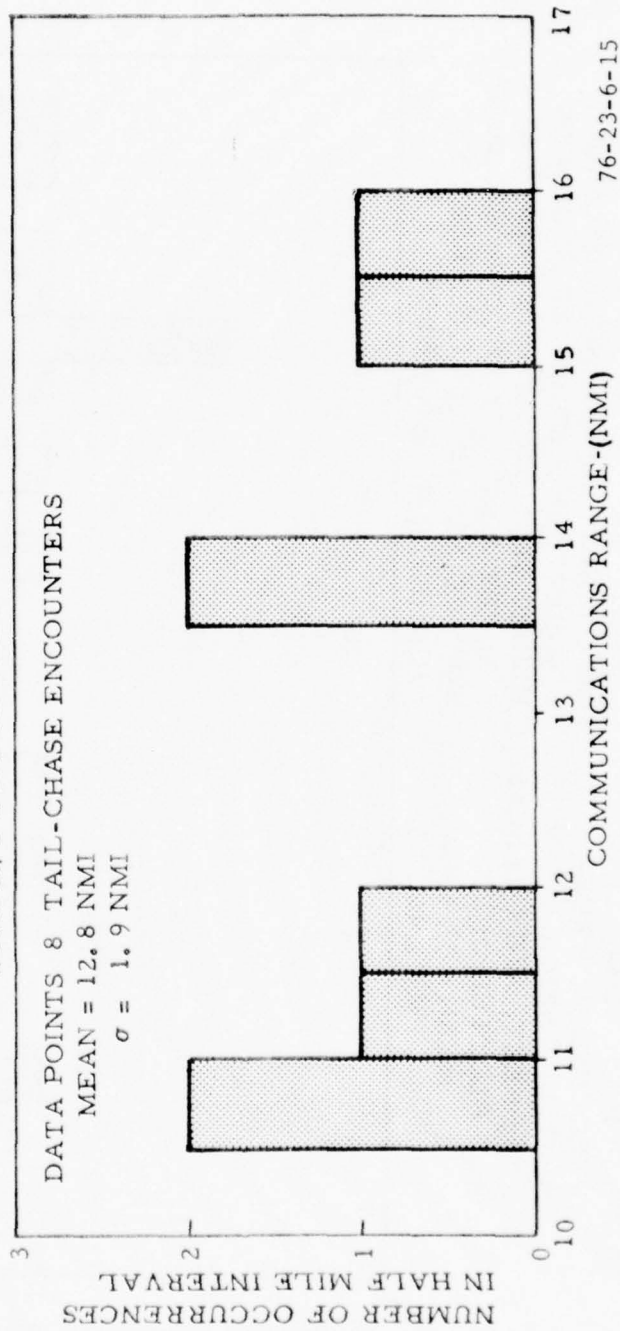

FIGURE 6-15. COMMUNICATIONS RANGE FLIGHT 54

The following flight, flight 38, flown on July 28, 1975 (figures 6-16, 6-17, and 6-18) contains additional information on another three-aircraft encounter. A/C 3 (N42) and A/C 2 (N376) were engaged in reverse figure-eight head-on encounters, while A/C 1 (N377) flew the single daisy. The pattern was started with A/C 1 and A/C 2 in a tail chase and head-on with A/C 3. The true altitudes were as follows: A/C 3 (11,000 feet), A/C 2 (9,000 feet), and A/C 1 (7,000 feet); however A/C 2 and A/C1 ATCRBS altitudes were simulated to 8.5k, and 8.0k feet, respectively. Head-on closing speed was 400 knots between the head-on encounter. This was maintained throughout the flight. The data track (figure 6-16) of A/C 3 versus A/C 2 was broken into two means. The 10 encounters, starting with the maximum range, show a mean of 30.6 nmi, while the clustering of the lower five encounters show a mean value of 15 nmi. These differences occurred when the aircraft traversed one leg at the longer distance and required new starting points to correct for wind (crab angle correction) going in the opposite direction. Figure 6-17 gives the data recorded in A/C 1 which was traversing the flight in a single-daisy pattern. The communication range values at the 180° encounter were well above the limits for maximum communication's range encounter. The range at the shallower angles, as stated before, is geometry limited. In figure 6-18 another part of this flight where the Mini-CAS was encountering the CAU also indicates a head-on link above 15 nmi. Margins for the larger mean of figure 6-16 are 6 dB.

Analyzing each of the communication range flights in detail was attempted. The power budget margins were brought out and extrapolated to closing velocities of 1,000 and 1,200 knots unless otherwise noted. As shown in most flights, the margins were exceeded, and only pattern limitation prevented the total air-to-air range at all angles from being investigated. From the acceptance test flights conducted in November and December 1974, upwards of 97-nmi RF link air-to-air ranges were recorded for the CAU equipments. This limitation in range was due to instrumentation design and could possibly have been much higher. Nevertheless, using this range value and extrapolating for two 1,800-knot aircraft encountering (3,600 knots) head-on, where the required communication range is 40 nmi with the 97-nmi limited value, this would allow for a 7.7-dB margin against Mach-2 supersonic aircraft.

#### COMMUNICATIONS RELIABILITY.

Communications reliability is another important key in implementing the CAS system, since each aircraft must periodically (every epoch) exchange data with another equipped aircraft within communication range. If the reliability figure is low, chances of detecting an intruding aircraft are reduced, thus limiting the effectiveness of the CAS concept.

Communications reliability was determined by checking several thousand receptions and transmissions from two- and three-aircraft encounters. Synchronization reliability was also determined, as was accuracy during this flight series, and is reported in the section following. The test for time slot occupants was made periodically by the CAU and Mini-CAS. When this check was being made, the CAS slot data were suppressed or retransmitted in a future slot. These points of slot data interruption were identified and deleted from the analysis. This was done in order to get a true transmit-receive reliability figure of merit. A report on the slot-checking occurrence rate can be found in chapter 8.

COMMUNICATIONS RANGE AS A  
 FUNCTION OF THE ANGLE BETWEEN  
 RADIALS FLOWN, FLIGHT 38, JULY 28, 1975  
 A/C 3 (CAU 2) VS. A/C 2 (MINI-CAS 1)

THREE AIRCRAFT ENCOUNTER WHERE  
 N42 (TRUE ALTITUDE WAS 11.0K FEET)  
 SIMULATED TO 9K, N376 (TRUE ALTITUDE  
 9K) SIMULATED TO 8.5K FEET AND N377  
 (TRUE ALTITUDE 7K FEET) SIMULATED  
 TO 8K FEET.

DATA SAMPLE:

15 (HEAD-ON) COLLISION ENCOUNTERS

ALTITUDE SEPARATION OF 2,000 FEET  
 (ABOVE AND BELOW 10,000 FEET)

x TRACK OF A/C 2 (N376) BY A/C 3 (N42)

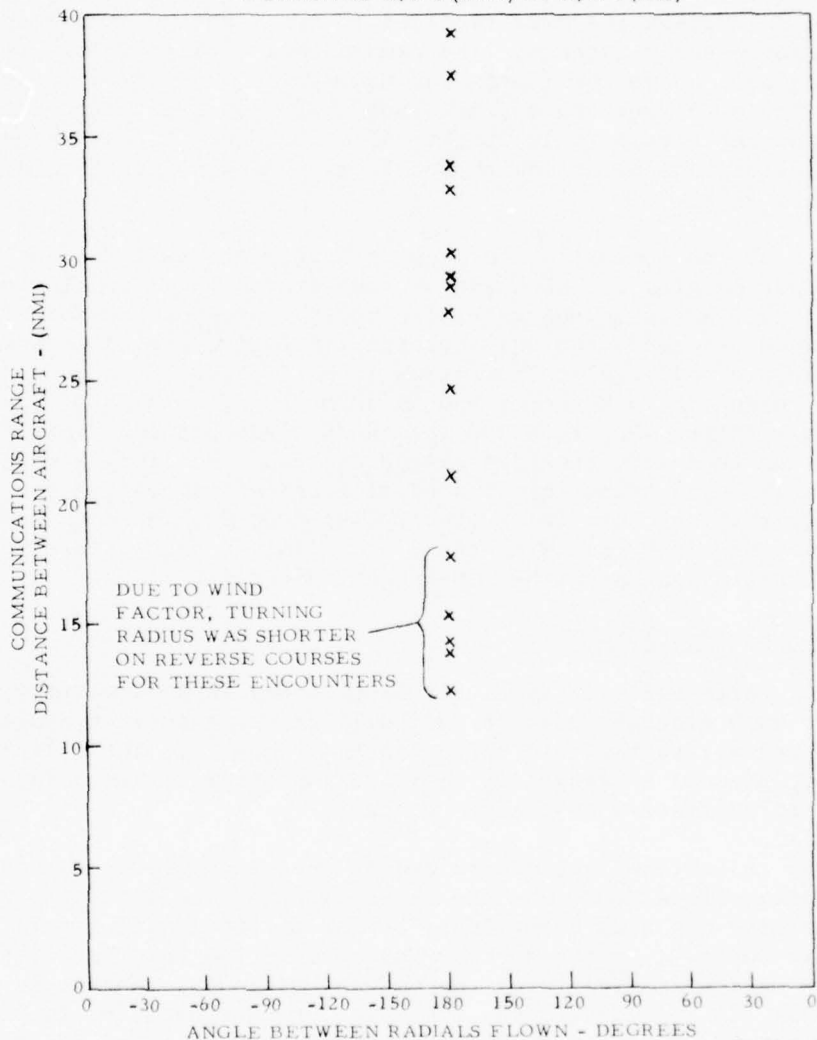
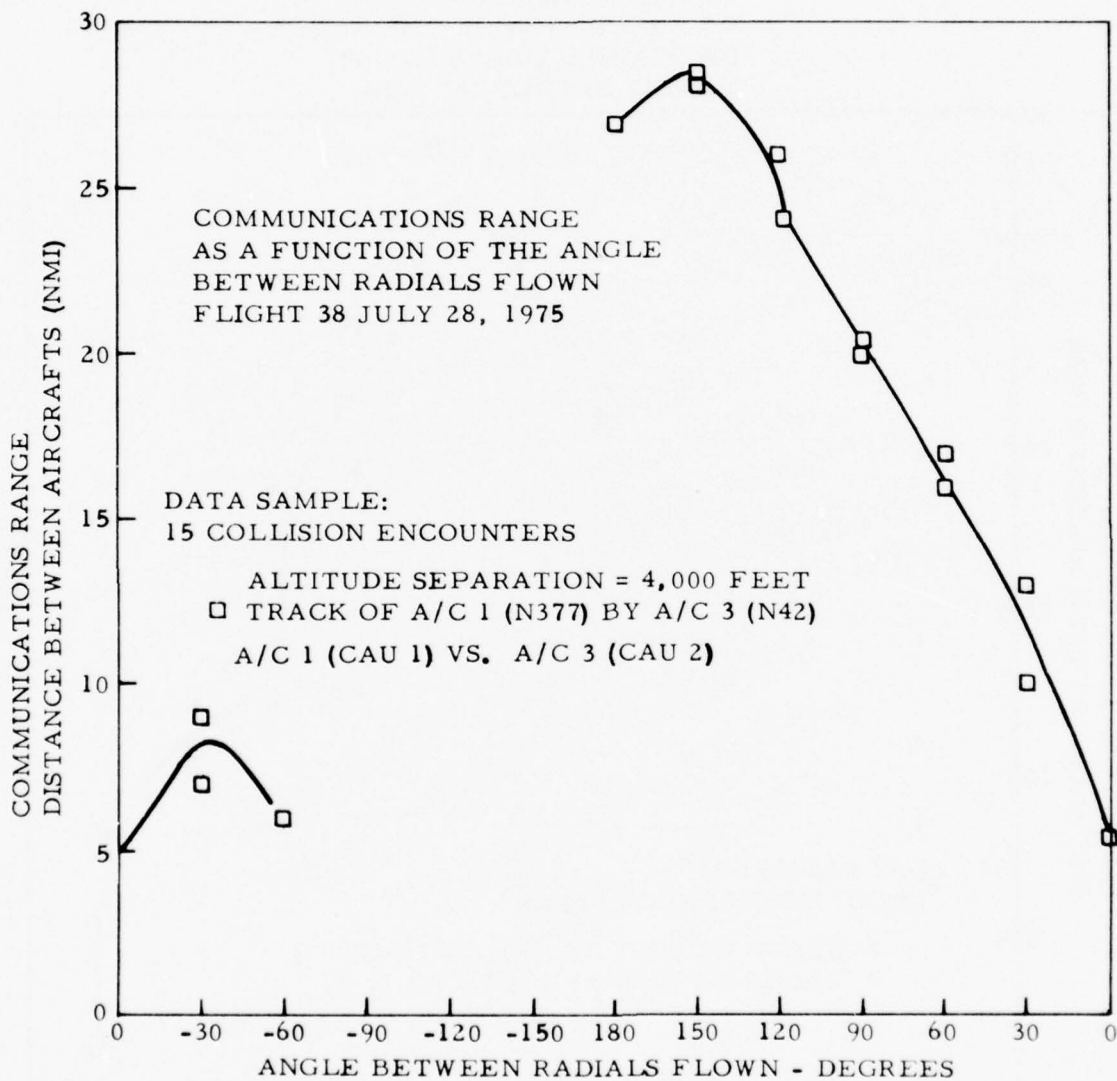

FIGURE 6-16. COMMUNICATIONS RANGE FLIGHT 38, THREE-AIRCRAFT ENCOUNTER



76-23-6-17

FIGURE 6-17. COMMUNICATIONS RANGE FLIGHT 38, THREE-AIRCRAFT ENCOUNTER

THREE AIRCRAFT ENCOUNTER,  
 WHERE N377 ALTITUDE 7.0K FEET  
 WAS ATCRBS TEST SIMULATED TO  
 8K AND N376 SIMULATED TO 8.5K FEET.

COMMUNICATION RANGE  
 AS A FUNCTION OF THE ANGLE  
 BETWEEN RADIALS FLOWN  
 FLIGHT 38 JULY 28, 1975

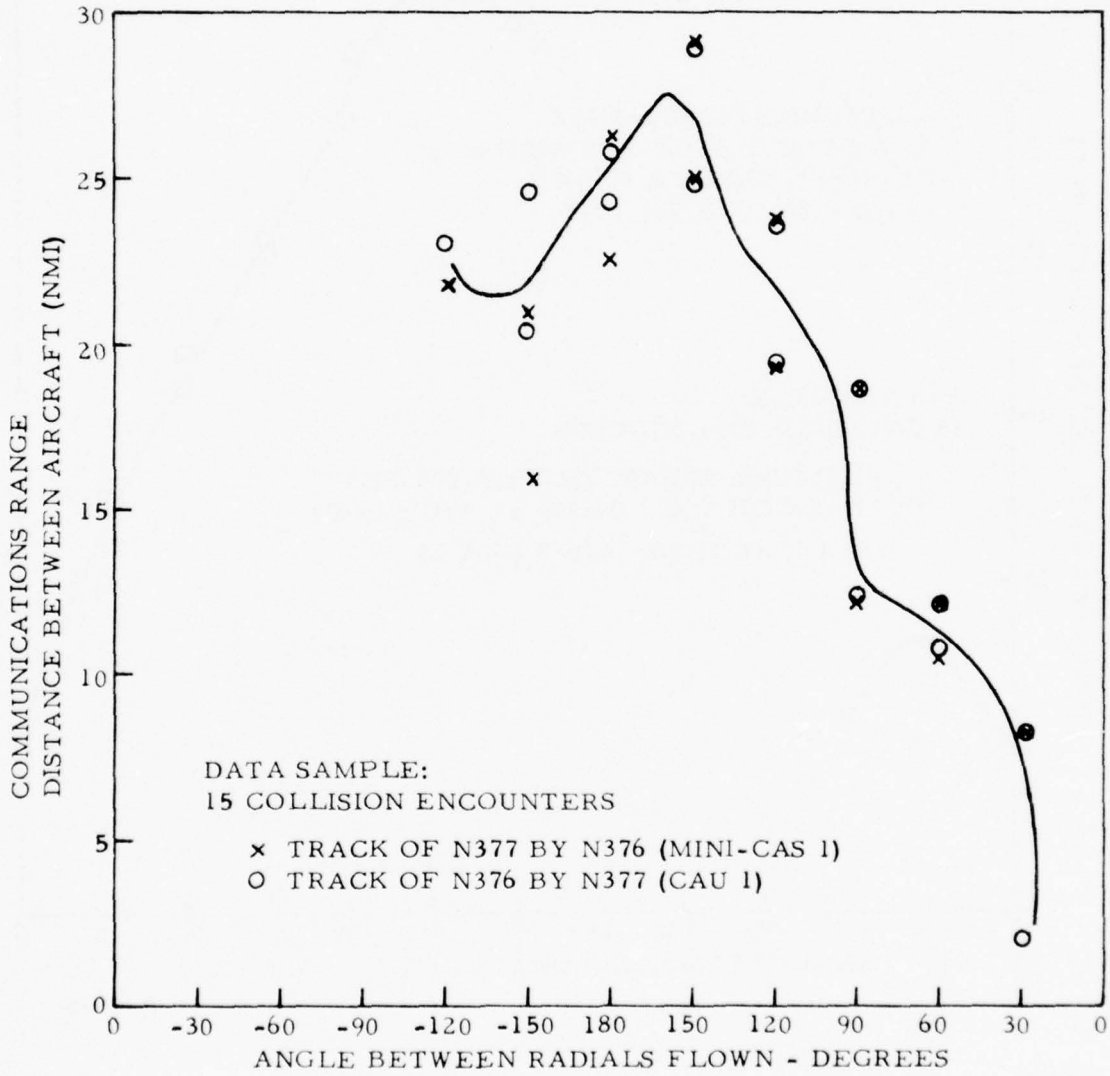

76-23-6-18

FIGURE 6-18. COMMUNICATIONS RANGE FLIGHT 38, THREE-AIRCRAFT ENCOUNTER

The communication reliability data was recorded during the single and double-daisy flight series. As before, this series also provided the range, synchronization, and warning time data for analysis. Additional flights were made over the NAFEC instrumentation range, which provided reliability data for short-range testing in the vicinity of the ground station.

The material provided on the printout of figure 6-19 (input data A/C 1) and figure 6-20 (input data A/C 2) is an indication of the quality of the recorded data. These particular data sample printouts from flight 15 (June 3, 1975) were recorded from the instrumentation photopanel. The film was read and transferred from card to magnetic tape for comparison processing with the other aircraft.

The following is a description of each column and other necessary details:

1. Type of input: BCD indicates photographic film was used to record data. Binary would indicate recording by magnetic tape thru tape interface.
2. Program type: Input data for Com Mod program.
3. Task Number: evaluation of MDEC ACAS equipments.
4. Date, Flight No: the date and flight number assigned.
5. Run Number, Pattern Type, Aircraft equipment configuration: this was run 1 of a single-daisy figure-eight flight, with A/C 2 starting at 270° and A/C 1 starting at 90°, with an angle of 180° between them (head-on encounter). The equipment under test A/C 1 (N377, Mini-CAS) and A/C 2 (N376, CAU).
6. Input data for A/C 1 ----page 1.
7. Time: hours, minutes, seconds, and tenths of second; code input from the synchronized onboard time clock.
8. DMS: Data message slot number of the intruder.

DATA MESSAGE SLOT INFORMATION.

HI: DMS hierarchy status (00-63) decoded from the message received.

dR/dT: range rate (dR/dT) is the relative velocity between "own" aircraft and intruder "DMS" aircraft.

A: sign of dR/dT "1" indicates aircraft range rate is positive and aircraft are closing on each other.

S: indicates resync triad was transmitted to the DMS by the onboard CAU.

RNG: the slant range between own aircraft and DMS aircraft in nmi.

Alt: altitude of the DMS in hundreds of feet.

# BEST AVAILABLE COPY

BCD INPUT CAS CARD/MAG REDUCTION--COMMODOE FLT. 15 6/3/75  
 CAS 052-241-000 6-3-75 FLIGHT NO. 15 N377 N376  
 RUN NO. 1 SIMDSY 270-180/90-180 N377(N1) N376(CAU)

INPUT DATA FOR A/C 1 DATA RUN 1

PAGE 1

TIME	HR	SEC	DMS	HI	DROT	A	S	RNG	ALT	RNG/R	B	B	BDG	HI	SYNC	DMS	XALT	RRX10	EPCH	SEL	ALT	RUN	AFC	#F85	HT	
																				SL	BQ*AL	H*REA	DAG*DAZAB	ZACZ*WF	HENC*SI2	L0512
9/58/39.2	721	0	280	1	0	15.7	87	28	0	0	154.8	0	0	517	80	99999	930*	10	00*11	00*000	000*00110	11010*1	0*00000	00000		
9/58/42.2	721	0	300	1	0	15.2	85	28	0	0	154.8	0	0	517	80	99999	951*	10	00*11	00*010	000*00110	11010*1	0*00000	00000		
9/58/45.2	721	0	300	1	0	14.9	85	28	0	0	154.8	0	0	517	80	14193	952*	10	00*11	00*011	000*00110	11010*1	0*00000	00000		
9/58/48.2	721	0	320	1	0	14.7	85	28	0	0	99999	0	0	517	80	99999	953*	10	00*11	00*010	000*00110	11010*1	0*00000	00000		
9/58/51.2	721	0	340	1	0	14.4	85	28	0	0	700	0	0	517	80	99999	954*	10	00*11	00*000	000*00110	11010*1	0*00000	00000		
9/58/54.2	721	0	380	1	0	14.1	86	28	0	0	154.8	0	0	517	80	99999	955*	10	00*11	00*010	000*00110	11010*1	0*00000	00000		
9/58/57.2	721	0	300	1	0	13.9	85	28	0	0	174.0	0	0	517	80	14193	956*	10	00*11	00*011	000*00110	11010*1	0*00000	00000		
9/59/0.2	721	0	380	1	0	13.6	86	28	0	0	99999	0	0	517	999	99999	957*	10	00*11	00*010	000*00110	11010*1	0*00000	00000		
9/59/3.2	721	0	300	1	0	13.3	85	28	0	0	207.8	0	0	517	80	14193	958*	10	00*11	00*011	000*00110	11010*1	0*00000	00000		
9/59/6.2	721	0	360	1	0	13.0	86	28	0	0	154.8	0	0	517	80	14194	959*	10	00*11	00*011	000*00110	11010*1	0*00000	00000		
9/59/9.2	721	99	99999	1	09999	9	999	99999	9	999	99999	0	0	517	80	14193	960*	10	00*11	00*011	000*00110	11010*1	0*00000	00000		
9/59/12.2	721	0	360	1	0	12.4	86	28	0	0	99999	0	0	517	80	14194	961*	10	00*11	00*011	000*00110	11010*1	0*00000	00000		
9/59/15.2	721	0	380	1	0	12.1	85	28	0	0	707.8	0	0	517	80	14193	962*	10	00*11	00*011	000*00110	11010*1	0*00000	00000		
9/59/18.2	721	0	360	1	0	11.8	86	28	0	0	99999	0	0	517	80	14194	963*	10	00*11	00*011	000*00110	11010*1	0*00000	00000		
9/59/21.2	721	0	380	1	0	11.4	86	28	0	0	463.8	0	0	517	80	99999	964*	10	00*11	00*010	000*00110	11010*1	0*00000	00000		
9/59/24.2	721	0	380	1	0	11.1	85	28	0	0	99999	0	0	517	80	99999	965*	10	00*11	00*010	000*00110	11010*1	0*00000	00000		
9/59/27.2	721	0	360	1	0	10.9	86	28	0	0	71.8	0	0	517	80	99999	966*	10	00*11	00*010	000*00110	11010*1	0*00000	00000		
9/59/30.2	721	0	380	1	0	10.6	85	28	0	0	99999	0	0	517	80	99999	967*	10	00*11	00*010	000*00110	11010*1	0*00000	00000		
9/59/33.2	721	0	340	1	0	10.4	85	28	0	0	263.8	0	0	517	80	99999	968*	10	00*11	00*010	000*00110	11010*1	0*00000	00000		
9/59/36.2	721	0	340	1	0	10.0	85	28	0	0	154.8	0	0	517	80	99999	969*	10	00*11	00*010	000*00110	11010*1	0*00000	00000		
9/59/39.2	721	0	360	1	0	9.8	85	28	0	0	174.0	0	0	517	999	99999	970*	10	00*11	00*010	000*00110	11010*1	0*00000	00000		
9/59/42.2	721	99	99999	1	09999	9	999	99999	9	999	99999	0	0	517	80	99999	971*	10	00*11	00*010	000*00110	11010*1	0*00000	00000		
9/59/45.2	721	0	340	1	0	9.2	86	28	0	0	70.8	0	0	517	80	14192	972*	10	00*11	00*001	000*00110	11010*1	0*00000	00000		
9/59/48.2	721	0	400	1	0	8.7	86	28	0	0	154.8	0	0	517	80	14196	973*	10	00*11	00*010	000*00110	11010*1	0*00000	00000		
9/59/51.2	721	0	300	1	0	8.6	86	28	0	0	174.0	0	0	517	80	14194	974*	10	00*11	00*011	000*00110	11010*1	0*00000	00000		
9/59/54.2	721	0	340	1	0	8.3	85	28	0	0	99999	0	0	517	80	14194	975*	10	00*11	00*011	000*00110	11010*1	0*00000	00000		
9/59/57.2	721	0	360	1	0	8.0	86	28	0	0	70.8	0	0	517	80	99999	976*	10	00*11	00*010	000*00110	11010*1	0*00000	00000		
10/0/0.2	721	99	99999	1	09999	9	999	99999	9	999	99999	0	0	517	80	99999	977*	10	00*11	00*010	000*00110	11010*1	0*00000	00000		
10/0/3.2	721	0	360	1	0	7.5	85	28	0	0	186.8	0	0	517	80	99999	978*	10	00*11	00*010	000*00110	11010*1	0*00000	00000		
10/0/6.2	721	0	320	1	0	7.2	86	28	0	0	99999	0	0	517	80	99999	979*	10	00*11	00*010	000*00110	11010*1	0*00000	00000		
10/0/9.2	721	0	320	1	0	7.0	86	29	0	0	70.8	0	0	517	80	14192	980*	10	00*11	00*011	000*00110	11010*1	0*00000	00000		
10/0/12.2	721	0	360	1	0	6.6	86	28	0	0	99999	0	0	517	80	14196	981*	10	00*11	00*011	000*00110	11010*1	0*00000	00000		
10/0/15.2	721	0	300	1	0	6.4	86	28	0	0	97.8	0	0	517	80	99999	982*	10	00*11	00*010	000*00110	11010*1	0*00000	00000		
10/0/18.2	721	0	340	1	0	6.1	85	28	0	0	154.8	0	0	517	80	99999	983*	10	00*11	00*010	000*00110	11010*1	0*00000	00000		
10/0/21.2	721	0	340	1	0	5.8	85	28	0	0	126.8	0	0	517	80	99999	984*	10	00*11	00*010	000*00110	11010*1	0*00000	00000		
10/0/24.2	721	0	340	1	0	5.3	86	28	0	0	99999	0	0	517	80	99999	985*	10	00*11	00*010	000*00110	11010*1	0*00000	00000		
10/0/27.2	721	0	340	1	0	5.2	86	28	0	0	97.8	0	0	517	80	99999	986*	10	00*11	00*000	000*00110	11010*1	0*00100	00000		
10/0/30.2	721	0	360	1	0	5.0	86	28	0	0	144.8	0	0	517	80	99999	987*	10	00*11	00*010	000*00110	11010*1	0*00100	00000		
10/0/33.2	721	0	380	1	0	4.7	86	28	0	0	174.0	0	0	517	80	99999	988*	10	00*11	00*010	000*00110	11010*1	0*00100	00000		
10/0/36.2	721	99	99999	1	09999	9	999	99999	9	999	99999	0	0	517	80	99999	989*	10	00*11	00*010	000*00110	11010*1	0*00100	00000		
10/0/39.2	721	0	340	1	0	4.2	85	28	0	0	70.8	0	0	517	80	99999	990*	10	00*11	00*000	000*00110	11010*1	0*00100	00000		
10/0/42.2	721	0	280	1	0	3.9	86	28	0	0	144.8	0	0	517	80	99999	991*	10	00*11	00*010	000*00110	11010*1	0*00100	00000		
10/0/45.2	721	0	320	1	0	3.6	85	28	0	0	186.8	0	0	517	80	99999	992*	10	00*11	00*010	000*00110	11010*1	0*00100	00000		
10/0/48.2	721	0	340	1	0	3.4	85	28	0	0	99999	0	0	517	80	99999	993*	10	00*11	00*010	000*00110	11010*1	0*00100	00000		
10/0/51.2	721	0	320	1	0	3.1	85	28	0	0	70.8	0	0	517	80	14193	994*	10	00*11	00*010	000*00110	11010*1	0*00100	00000		
10/0/54.2	721	0	340	1	0	2.8	86	28	0	0	99999	0	0	517	999	99999	995*	10	00*11	00*010	000*00110	11010*1	0*00100	00000		

BCD INPUT CAS CARD/MAG REDUCTION--COMMODOE FLT. 15 6/3/75 DOUBLE DAISY  
 CAS 052-241-000 6-3-75 FLIGHT NO. 15 N377 N376  
 RUN NO. 1 SIMDSY 270-180/90-180 N377(N1) N376(CAU)

INPUT DATA FOR A/C 1 DATA RUN 1

PAGE 2

TIME	HR	SEC	DMS	HI	DROT	A	S	RNG	ALT	RNG/R	B	B	BDG	HI	SYNC	DMS	XALT	RRX10	EPCH	SEL	ALT	RUN	AFC	#F85	HT	
																				SL	BQ*AL	H*REA	DAG*DAZAB	ZACZ*WF	HENC*SI2	L0512
10/0/57.2	721	0	340	1	0	2.5	86	28	0	0	154.8	0	0	517	80	99999	996*	10	00*11	00*000	000*00110	11010*1	0*00100	00000		
10/0/0.2	721	0	320	1	0	2.3	86	28	0	0	99999	0	0	517	80	99999	997*	10	00*11	00*010	000*00110	11010*1	0*00100	00000		
10/0/3.2	721	0	340	1	0	2.0	85	28	0	0	97.8	0	0	517	80	99999	998*	10	00*11	00*000	000*00110	11010*1	0*00100	01000		
10/0/6.2	721	0	340	1	0	1.8	85	28	0	0	154.8	0	0	517	80	99999	999*	10	00*11	00*010	000*00110	11010*1	0*00100	01000		
10/0/9.2	721	0	320	1	0	1.5	85	28	0	0	99999	0														

BEST AVAILABLE COPY

BCD INPUT CAS CARD/MAG REDUCTION--COMMODORE FLT.15 6/3/75 DOUBLE DAISS  
 CAS 052-241-000 6-3-75 FLIGHT NO. 15 N377 N376  
 RUN NO. 2 SINDSY 75-180/255-180 N377HINT1 N376CAUI

INPUT DATA FOR A/C 1 DATA RUN 2

PAGE 5

TIME	*	DMS	*	DMS	*	SFL	* ALT *	RUN *	ATC	*FRS*	NI															
HR MN	SEC	DMS	MI	DROT	A S	RNG	ALT	RNG/R	B	D	BODY*	HI	SYNC	DMS	XALT	NRXID	EPCH*	SL	RG*AL	H*REA	JAG*	QAZZ	Z4C24*	F	H*NC312	L0512
10/ 6/ 0.20	721	0	0	10	17.0	86	-0	0	0	1548	0	0	517	80	99999	1099*	10	70*11	00*010	000*00110	11010*1	0*00000	00000			
10/ 6/ 9.20	721	0	0	10	16.8	87	-0	0	0	1740	0	0	517	80	14195	1100*	10	70*11	00*011	000*00110	11010*1	0*00000	00000			
10/ 6/ 15.20	721	0	0	10	16.5	86	-0	0	0	9709	0	0	517	80	99999	1101*	10	70*11	00*010	000*00110	11010*1	0*00000	00000			
10/ 6/ 15.20	721	0	320	10	16.2	86	-28	0	0	79*	0	0	517	80	14193	1102*	10	70*11	00*011	000*00110	11010*1	0*00000	00000			
10/ 6/ 18.20	721	0	300	10	15.9	86	-28	0	0	1548	0	0	517	80	99999	1103*	10	70*11	00*010	000*00110	11010*1	0*00000	00000			
10/ 6/ 21.20	721	0	380	10	15.6	86	-28	0	0	1740	0	0	517	80	14193	1104*	10	70*11	00*011	000*00110	11010*1	0*00000	00000			
10/ 6/ 24.20	721	0	340	10	15.3	86	-28	0	0	9999	0	0	517	80	14192	1105*	10	70*11	00*011	000*00110	11010*1	0*00000	00000			
10/ 6/ 27.20	721	0	340	10	15.0	85	-28	0	0	79*	0	0	517	80	14195	1106*	10	70*11	00*011	000*00110	11010*1	0*00000	00000			
10/ 6/ 30.20	721	99	9999	10	9999	9999	9999	9999	0	724*	0	0	517	80	99999	1107*	10	70*11	00*011	000*00110	11010*1	0*00000	00000			
10/ 6/ 33.20	721	0	340	10	14.5	86	26	0	0	1548	0	0	517	80	14193	1108*	10	70*11	00*011	000*00110	11010*1	0*00000	00000			
10/ 6/ 36.20	721	0	400	10	14.1	86	26	0	0	1548	0	0	517	80	99999	1109*	10	70*11	00*010	000*00110	11010*1	0*00000	00000			
10/ 6/ 39.20	721	0	380	10	13.9	85	26	0	0	1740	0	0	517	80	14194	1110*	10	70*11	00*011	000*00110	11010*1	0*00000	00000			
10/ 6/ 42.20	721	0	360	10	13.6	86	26	0	0	9999	0	0	517	80	14192	1111*	10	70*11	00*011	000*00110	11010*1	0*00000	00000			
10/ 6/ 45.20	721	0	380	10	13.3	86	26	0	0	79*	0	0	517	80	14195	1112*	10	70*11	00*011	000*00110	11010*1	0*00000	00000			
10/ 6/ 48.20	721	0	360	10	13.0	86	26	0	0	1548	0	0	517	80	14192	1113*	10	70*11	00*011	000*00110	11010*1	0*00000	00000			
10/ 6/ 51.20	721	0	380	10	12.7	85	26	0	0	1740	0	0	517	80	14195	1114*	10	70*11	00*011	000*00110	11010*1	0*00000	00000			
10/ 6/ 54.20	721	0	380	10	12.4	85	26	0	0	9999	0	0	517	80	99999	1115*	10	70*11	00*010	000*00110	11010*1	0*00000	00000			
10/ 6/ 57.20	721	0	340	10	12.1	86	17	0	0	79*	0	0	517	80	14193	1116*	10	70*11	00*011	000*00110	11010*1	0*00000	00000			
10/ 7/ 0.20	721	0	380	10	11.8	86	17	0	0	1548	0	0	517	80	14194	1117*	10	70*11	00*011	000*00110	11010*1	0*00000	00000			
10/ 7/ 3.20	721	0	380	10	11.5	85	17	0	0	1740	0	0	517	80	14193	1118*	10	70*11	00*011	000*00110	11010*1	0*00000	00000			
10/ 7/ 6.20	721	0	380	10	11.1	85	26	0	0	9999	0	0	517	80	14192	1119*	10	70*11	00*011	000*00110	11010*1	0*00000	00000			
10/ 7/ 9.20	721	0	400	10	10.9	85	26	0	0	79*	0	0	517	80	14196	1120*	10	70*11	00*011	000*00110	11010*1	0*00000	00000			
10/ 7/ 12.20	721	0	380	10	10.6	86	17	0	0	1548	0	0	517	80	99999	1121*	10	70*11	00*010	000*00110	11010*1	0*00000	00000			
10/ 7/ 15.20	721	0	380	10	10.3	85	26	0	0	1740	0	0	517	80	14194	1122*	10	70*11	00*011	000*00110	11010*1	0*00000	00000			
10/ 7/ 18.20	721	0	380	10	10.0	85	17	0	0	9999	0	0	517	80	14194	1123*	10	70*11	00*011	000*00110	11010*1	0*00000	00000			
10/ 7/ 21.20	721	0	380	10	9.6	85	17	0	0	1485	0	0	517	999	99999	1124*	10	70*11	00*010	000*00110	11010*1	0*00000	00000			
10/ 7/ 24.20	721	0	400	10	9.3	85	26	0	0	1548	0	0	517	80	14194	1125*	10	70*11	00*011	000*00110	11010*1	0*00000	00000			
10/ 7/ 27.20	721	0	380	10	9.0	86	26	0	0	1740	0	0	517	80	14192	1126*	10	70*11	00*011	000*00110	11010*1	0*00000	00000			
10/ 7/ 30.20	721	0	380	10	8.7	86	26	0	0	9999	0	0	517	80	99999	1127*	10	70*11	00*011	000*00110	11010*1	0*00000	00000			
10/ 7/ 33.20	721	0	420	10	8.3	85	26	0	0	79*	0	0	517	80	14195	1128*	10	70*11	00*011	000*00110	11010*1	0*00000	00000			
10/ 7/ 36.20	721	99	9999	10	9999	9999	9999	9999	0	724*	0	0	517	80	14192	1129*	10	70*11	00*011	000*00110	11010*1	0*00000	00000			
10/ 7/ 39.20	721	0	400	10	7.7	85	17	0	0	1548	0	0	517	80	14195	1130*	10	70*11	00*011	000*00110	11010*1	0*00000	00000			
10/ 7/ 42.20	721	0	400	10	7.4	85	26	0	0	1548	0	0	517	80	14194	1131*	10	70*11	00*011	000*00110	11010*1	0*00000	00000			
10/ 7/ 45.20	721	0	400	10	7.1	85	27	0	0	1740	0	0	517	80	99999	1132*	10	70*11	00*010	000*00110	11010*1	0*00000	00000			
10/ 7/ 48.20	721	0	400	10	6.7	85	26	0	0	9999	0	0	517	80	99999	1133*	10	70*11	00*012	000*00110	11010*1	0*00000	00000			
10/ 7/ 51.20	721	0	400	10	6.4	85	26	0	0	207*	0	0	517	80	99999	1134*	10	70*11	00*010	000*00110	11010*1	0*00000	00000			
10/ 7/ 54.20	721	0	400	10	6.1	85	27	0	0	1548	0	0	517	80	99999	1135*	10	70*11	00*010	000*00110	11010*1	0*00000	00000			
10/ 7/ 57.20	721	0	400	10	5.7	85	17	0	0	1740	0	0	517	80	14194	1136*	10	70*11	00*011	000*00110	11010*1	0*00000	00000			
10/ 8/ 0.20	721	0	420	10	5.4	86	30	0	0	9999	0	0	517	80	14195	1137*	10	70*11	00*010	000*00110	11010*1	0*00000	00000			
10/ 8/ 3.20	721	0	420	10	5.0	86	31	0	0	207*	0	0	517	999	99999	1138*	10	70*11	00*011	000*00110	11010*1	0*00000	00000			
10/ 8/ 6.20	721	0	400	10	4.8	86	26	0	0	1548	0	0	517	80	14191	1139*	10	70*11	00*011	000*00110	11010*1	0*00000	00000			
10/ 8/ 9.20	721	0	400	10	4.5	86	26	0	0	1740	0	0	517	80	99999	1140*	10	70*11	00*010	000*00110	11010*1	0*00000	00000			
10/ 8/ 12.20	721	0	400	10	4.1	85	17	0	0	9999	0	0	517	80	99999	1141*	10	70*11	00*010	000*00110	11010*1	0*00000	00000			
10/ 8/ 15.20	721	0	400	10	3.8	86	26	0	0	79*	0	0	517	80	99999	1142*	10	70*11	00*010	000*00110	11010*1	0*00000	00000			
10/ 8/ 18.20	721	0	400	10	3.5	86	17	0	0	9999	0	0	517	80	99999	1143*	10	70*11	00*010	000*00110	11010*1	0*00000	00000			
10/ 8/ 21.20	721	0	400	10	3.1	86	26	0	0	590*	0	0	517	80	99999	1144*	10	70*11	00*010	000*00110	11010*1	0*00000	00000			

BCD INPUT CAS CARD/MAG REDUCTION--COMMODORE FLT.15 6/3/75 DOUBLE DAISS  
 CAS 052-241-000 6-3-75 FLIGHT NO. 15 N377 N376  
 RUN NO. 2 SINDSY 75-180/255-180 N377HINT1 N376CAUI

INPUT DATA FOR A/C 1 DATA RUN 2

PAGE 6

TIME	*	DMS	*	DMS	*	SFL	* ALT *	RUN *	ATC	*FRS*	NI															
HR MN	SEC	DMS	MI	DROT	A S	RNG	ALT	RNG/R	B	D	BODY*	HI	SYNC	DMS	XALT	NRXID	EPCH*	SL	RG*AL	H*REA	JAG*	QAZZ	Z4C24*	F	H*NC312	L0512
10/ 8/ 24.20	721	0	400	10	2.8	86	26	0	0	1548	0	0	517	80	14194	1145*	10	70*11	00*011	000*00110	11010*1	0*00000	00000			
10/ 8/ 27.20	721	0	400	10	2.3	86	26	0	0	9999	0	0	517	80	99999	1146*	10	70*11	00*010	000*00110	11010*1	0*00000	00000			
10/ 8/ 30.20	721	0	400	10	2.1	86	17	0	0	199*	0	0	517	80	99999	1147*	10	70*11	00*010	000*00110	11010*1	0*00000	00000			
10/ 8/ 33.20	721	0	400	10	1.9	87	17	0	0	207*	0	0	517	80	99999	1148*	10	70*11	00*010	000*00110	11010*1	0*00000	00000			
10/ 8/ 36.20	721	0	400	10	1.6	87	26	0	0	9999	0	0	517	80	99999	1149*	10	70*11	00*010	000*00110	11010*1	0*00000	00000			
10/ 8/ 39.20	721	0	400	10	1.3	87	17	0	0	190*	0	0	517	80	99999	1150*	10	70*11								

# BEST AVAILABLE COPY

BCD INPUT CAS CARD/MAG REDUCTION--COMMODORE FLT.15 6/3/74 DOUBLE DAISY  
 CAS 032-241-000 6-2-75 FLIGHT NO. 13 N377 N378  
 RUN NO. 1 SINDSY 270-180/ 90-180 N377(N11) N376(CA1)

INPUT DATA FOR A/C 2 DATA RUN 1

PAGE 3

TIME	HR	MM	SEC	DMS	MI	DRT	A	S	DMS	ALT	ANG/A	B	D	BDG/YMI	SYNC	DMS	XALT	RRX10	EPCH	SEL	ALT	RUN	ATC	*FAS*	HI	
																				SL	SGPAL	H*REA	QAG*QAZR	ZACZ*AF	M*NC512	LD512
9/58/39.5	317	63	300	1	0	15.0	81	271	0	0	9999	2	2047	721	85	14191	950*	10	00*11	00*100	111*00110	10010*	0*00000	00000	00000	
9/58/42.5	317	63	340	1	0	15.3	81	294	0	0	1548*	3	2047	721	85	99999	951*	10	00*11	00*100	100*00110	10010*	0*00000	00000	00000	
9/58/45.5	317	63	320	1	0	15.0	80	392	0	0	9999*	3	2047	721	85	14194	952*	10	00*11	00*100	111*00110	10010*	0*00000	00000	00000	
9/58/48.5	317	63	300	1	0	14.7	81	331	0	0	1548*	4	2047	721	85	99999	953*	10	00*11	00*100	100*00110	10010*	0*00000	00000	00000	
9/58/51.5	317	63	300	1	0	14.4	81	299	0	0	9999*	4	2047	721	85	14192	954*	10	00*11	00*100	111*00110	10010*	0*00000	00000	00000	
9/58/54.5	317	63	300	1	0	14.1	81	340	0	0	1548*	1	1548	721	85	14192	955*	10	00*11	00*100	101*00110	10010*	0*00000	00000	00000	
9/58/57.5	317	63	300	1	0	13.9	80	300	0	0	9999*	1	2047	721	85	14192	956*	10	00*11	00*100	111*00110	10010*	0*00000	00000	00000	
9/59/0.5	317	63	340	1	0	13.9	80	318	0	0	1548*	1	2047	721	85	99999	957*	10	00*11	00*100	100*00110	10010*	0*00000	00000	00000	
9/59/3.5	317	63	320	1	0	13.0	80	292	0	0	9999*	1	2047	721	85	14192	958*	10	00*11	00*100	111*00110	10010*	0*00000	00000	00000	
9/59/6.5	317	63	300	1	0	12.7	80	318	0	0	9999*	1	1548	721	85	14192	960*	10	00*11	00*100	100*00110	10010*	0*00000	00000	00000	
9/59/9.5	317	63	300	1	0	12.4	81	281	0	0	1548*	1	1548	721	85	14192	961*	10	00*11	00*100	101*00110	10010*	0*00000	00000	00000	
9/59/12.5	317	63	300	1	0	12.1	80	265	0	0	9999*	1	2047	721	85	14192	962*	10	00*11	00*100	111*00110	10010*	0*00000	00000	00000	
9/59/15.5	317	63	300	1	0	11.8	81	283	0	0	1548*	1	1548	721	85	14191	963*	10	00*11	00*100	101*00110	10010*	0*00000	00000	00000	
9/59/18.5	317	63	300	1	0	11.5	81	299	0	0	9999*	1	1548	721	85	14193	964*	10	00*11	00*100	111*00110	10010*	0*00000	00000	00000	
9/59/21.5	317	63	340	1	0	11.2	81	297	0	0	1548*	1	2047	721	85	99999	965*	10	00*11	00*100	100*00110	10010*	0*00000	00000	00000	
9/59/24.5	317	63	300	1	0	11.0	81	300	0	0	9999*	1	1548	721	85	14193	966*	10	00*11	00*100	111*00110	10010*	0*00000	00000	00000	
9/59/27.5	317	63	300	1	0	10.7	81	282	0	0	1548*	2	1548	721	85	14194	967*	10	00*11	00*100	101*00110	10010*	0*00000	00000	00000	
9/59/30.5	317	63	300	1	0	10.4	80	303	0	0	9999*	1	1548	721	85	14192	968*	10	00*11	00*100	111*00110	10010*	0*00000	00000	00000	
9/59/33.5	317	63	300	1	0	10.1	81	298	0	0	1548*	1	1548	721	85	14192	969*	10	00*11	00*100	110*00110	10010*	0*00000	00000	00000	
9/59/36.5	317	63	300	1	0	9.8	81	321	0	0	9999*	1	2047	721	85	14192	970*	10	00*11	00*100	100*00110	10010*	0*00000	00000	00000	
9/59/39.5	317	63	300	1	0	9.5	81	294	0	0	1548*	1	2047	721	85	99999	971*	10	00*11	00*100	100*00110	10010*	0*00000	00000	00000	
9/59/42.5	317	63	300	1	0	9.2	81	321	0	0	9999*	1	2047	721	85	14192	972*	10	00*11	00*100	111*00110	10010*	0*00000	00000	00000	
9/59/45.5	317	63	300	1	0	8.9	81	333	0	0	1548*	1	1548	721	85	14192	973*	10	00*11	00*100	101*00110	10010*	0*00000	00000	00000	
9/59/48.5	317	63	300	1	0	8.6	81	278	0	0	9999*	1	2047	721	85	14192	974*	10	00*11	00*100	111*00110	10010*	0*00000	00000	00000	
9/59/51.5	317	63	320	1	0	8.3	81	274	0	0	1548*	1	2047	721	85	99999	975*	10	00*11	00*100	100*00110	10010*	0*00000	00000	00000	
9/59/54.5	317	63	340	1	0	8.0	81	300	0	0	9999*	1	2047	721	85	14192	976*	10	00*11	00*100	111*00110	10010*	0*00000	00000	00000	
9/59/57.5	317	63	300	1	0	7.8	81	299	0	0	1548*	1	2047	721	85	99999	977*	10	00*11	00*100	100*00110	10010*	0*00000	00000	00000	
10/0/0.5	317	63	340	1	0	7.6	81	217	0	0	9999*	1	1548	721	85	14192	978*	10	00*11	00*100	111*00110	10010*	0*00000	00000	00000	
10/0/3.5	317	63	300	1	0	7.4	81	317	0	0	1548*	1	1548	721	85	99999	979*	10	00*11	00*100	100*00110	10010*	0*00000	00000	00000	
10/0/6.5	317	63	300	1	0	7.2	81	242	0	0	9999*	1	2047	721	85	99999	980*	10	00*11	00*100	110*00110	10010*	0*00000	00000	00000	
10/0/9.5	317	63	300	1	0	7.0	81	203	0	0	1548*	2	1548	721	85	99999	981*	10	00*11	00*100	100*00110	10010*	0*00000	00000	00000	
10/0/12.5	317	63	300	1	0	6.8	81	218	0	0	9999*	2	2047	721	85	99999	982*	10	00*11	00*100	110*00110	10010*	0*00000	00000	00000	
10/0/15.5	317	63	300	1	0	6.6	81	310	0	0	1548*	3	1548	721	85	99999	983*	10	00*11	00*100	100*00110	10010*	0*00000	00000	00000	
10/0/18.5	317	63	340	1	0	6.1	80	310	0	0	9999*	3	1548	721	85	99999	984*	10	00*11	00*100	110*00110	10010*	0*00000	00000	00000	
10/0/21.5	317	63	320	1	0	5.8	81	282	0	0	1548*	4	1548	721	85	14192	985*	10	00*11	00*100	111*00110	10010*	0*00000	00000	00000	
10/0/24.5	317	63	320	1	0	5.5	81	310	0	0	9999*	1	2047	721	85	14191	986*	10	00*11	00*100	101*00110	10010*	0*00000	00000	00000	
10/0/27.5	317	63	300	1	0	5.2	81	310	0	0	9999*	1	2047	721	85	14191	987*	10	00*11	00*100	100*00110	10010*	0*00000	00000	00000	
10/0/30.5	317	63	320	1	0	5.0	81	280	0	0	1548*	1	2047	721	85	99999	987*	10	00*11	00*100	100*00110	10010*	0*00000	00000	00000	
10/0/33.5	317	63	320	1	0	4.8	81	259	0	0	9999*	2	2047	721	85	14193	988*	10	00*11	00*100	111*00110	10010*	0*00000	00000	00000	
10/0/36.5	317	63	340	1	0	4.5	81	277	0	0	1548*	1	2047	721	85	99999	989*	10	00*11	00*100	100*00110	10010*	0*00000	00000	00000	
10/0/39.5	317	63	320	1	0	4.3	81	272	0	0	9999*	1	2047	721	85	14194	990*	10	00*11	00*100	100*00110	10010*	0*00000	00000	00000	
10/0/42.5	317	63	300	1	0	3.9	81	279	0	0	1548*	2	2047	721	85	99999	991*	10	00*11	00*100	111*00110	10010*	0*00000	00000	00000	
10/0/45.5	317	63	300	1	0	3.7	81	309	0	0	9999*	2	2047	721	85	14192	992*	10	00*11	00*100	111*00110	10010*	0*00000	00000	00000	
10/0/48.5	317	63	340	1	0	3.4	80	321	0	0	1548*	1	2047	721	85	99999	993*	10	00*11	00*100	100*00110	10010*	0*00000	00000	00000	
10/0/51.5	317	63	340	1	0	3.1	80	339	0	0	9999*	1	2047	721	85	14192	994*	10	00*11	00*100	111*00110	10010*	0*00000	00000	00000	
10/0/54.5	317	63	340	1	0	2.9	80	339	0	0	9999*	1	2047	721	85	99999	995*	10	00*11	00*100	100*00110	10010*	0*00000	00000	00000	

BCD INPUT CAS CARD/MAG REDUCTION--COMMODORE FLT.15 6/3/74 DOUBLE DAISY  
 CAS 032-241-000 6-2-75 FLIGHT NO. 13 N377 N378  
 RUN NO. 1 SINDSY 270-180/ 90-180 N377(N11) N376(CA1)

INPUT DATA FOR A/C 2 DATA RUN 1

PAGE 4

TIME	HR	MM	SEC	DMS	MI	DRT	A	S	DMS	ALT	ANG/A	B	D	BDG/YMI	SYNC	DMS	XALT	RRX10	EPCH	SEL	ALT	RUN	ATC	*FAS*	HI	
																				SL	SGPAL	H*REA	QAG*QAZR	ZACZ*AF	M*NC512	LD512
10/0/57.5	317	63	320	1	0	2.6	81	340	0	0	9999*	1	2047	721	85	99999	996*	10	00*11	00*100	110*00110	10010*	0*00000	00111	00111	
10/0/0.5	317	63	400	1	0	2.2	80	240	0	0	1548*	2	2047	721	85	99999	997*	10	00*11	00*100	100*00110	10010*	0*00000			

BEST AVAILABLE COPY

BCD INPUT CAS CARD/MAG REDUCTION--COMMODOE FLT.15 6/3/74 DOUBLE DAISY  
 CAS 052-241-000 6-3-75 FLIGHT NO. 13 N377 N370  
 RUN NO. 2 SINDSV 75-180/255-180 N377HINI) N370CAL)

INPUT DATA FOR A/C 2 DATA RUN 2 PAGE 7

TIME	HR	MM	SEC	DMS	HI	DRDT	A	S	DMS	RNG	ALT	RNG/R	B	D	BDG	HI	SYNC	DMS	SRXIO	EPCH	SEL	ALT	RUN	ATC	FRS	HI			
HR	MM	SEC	DMS	HI	DRDT	A	S	RNG	ALT	RNG/R	B	D	BDG	HI	SYNC	DMS	SRXIO	EPCH	SL	RG*AL	H*REA	QAG*QAZ48	ZACZ4*P	M*NC512	LD512				
10/ 9/ 0.30	517	63	300	1	0	17.1	81	261	0	1548	1	1548	721	85	14193	1099*	10	00	11	00	100	101	00110	10011*	0	00000	00000		
10/ 9/ 9.30	517	63	440	1	0	16.8	81	337	0	0999	1	1448	721	85	14194	1100*	10	00	11	00	100	111	00110	10011*	0	00000	00000		
10/ 9/12.30	517	63	380	1	0	16.5	81	291	0	1548	1	1548	721	85	14192	1101*	10	00	11	00	100	101	00110	10011*	0	00000	00000		
10/ 9/15.30	517	63	340	1	0	16.2	80	250	0	0999	1	2047	721	85	14191	1102*	10	00	11	00	100	111	00110	10011*	0	00000	00000		
10/ 9/18.30	517	99	9999	1	0	9999	9	999	9	9999	0	1548	1	2047	721	85	99999	1103*	10	00	11	00	100	111	00110	10011*	0	00000	00000
10/ 9/21.30	517	63	340	1	0	15.7	81	293	0	0999	2	2047	721	85	14193	1104*	10	00	11	00	100	101	00110	10011*	0	00000	00000		
10/ 9/24.30	517	63	320	1	0	15.4	81	279	0	1548	1	1548	721	85	14194	1105*	10	00	11	00	100	101	00110	10011*	0	00000	00000		
10/ 9/27.30	517	63	380	1	0	15.0	81	332	0	0999	1	1548	721	85	14191	1106*	10	00	11	00	100	111	00110	10011*	0	00000	00000		
10/ 9/30.30	517	63	300	1	0	14.8	81	290	0	1548	2	1548	721	85	14194	1107*	10	00	11	00	100	101	00110	10011*	0	00000	00000		
10/ 9/33.30	517	63	340	1	0	14.5	81	301	0	0999	2	1548	721	85	14192	1108*	10	00	11	00	100	101	00110	10011*	0	00000	00000		
10/ 9/36.30	517	99	9999	1	0	9999	9	999	9	9999	0	1548	1	1548	721	85	14192	1109*	10	00	11	00	100	101	00110	10011*	0	00000	00000
10/ 9/39.30	517	63	300	1	0	14.1	81	372	0	0999	1	2047	721	85	14191	1110*	10	00	11	00	100	111	00110	10011*	0	00000	00000		
10/ 9/42.30	517	63	320	1	0	13.7	81	350	0	1548	1	2047	721	85	99999	1111*	10	00	11	00	100	100	00110	10011*	0	00000	00000		
10/ 9/45.30	517	63	380	1	0	13.3	80	279	0	0999	2	2047	721	85	14193	1112*	10	00	11	00	100	111	00110	10011*	0	00000	00000		
10/ 9/48.30	517	63	300	1	0	13.1	81	301	0	1548	1	2047	721	85	99999	1113*	10	00	11	00	100	100	00110	10011*	0	00000	00000		
10/ 9/51.30	517	63	300	1	0	12.7	80	317	0	0999	1	2047	721	85	14194	1114*	10	00	11	00	100	100	00110	10011*	0	00000	00000		
10/ 9/54.30	517	63	400	1	0	12.4	81	380	0	1548	2	2047	721	85	99999	1115*	10	00	11	00	100	100	00110	10011*	0	00000	00000		
10/ 9/57.30	517	63	380	1	0	12.1	81	314	0	0999	2	2047	721	85	14192	1116*	10	00	11	00	100	111	00110	10011*	0	00000	00000		
10/ 7/ 0.30	517	63	380	1	0	11.8	80	332	0	1548	1	1548	721	85	14191	1117*	10	00	11	00	100	101	00110	10011*	0	00000	00000		
10/ 7/ 3.30	517	63	380	1	0	11.5	80	372	0	0999	1	1548	721	85	14191	1118*	10	00	11	00	100	111	00110	10011*	0	00000	00000		
10/ 7/ 6.30	517	63	300	1	0	11.2	81	351	0	1548	1	1548	721	85	99999	1119*	10	00	11	00	100	100	00110	10011*	0	00000	00000		
10/ 7/ 9.30	517	63	300	1	0	11.1	81	370	0	0999	2	1548	721	85	14194	1120*	10	00	11	00	100	100	00110	10011*	0	00000	00000		
10/ 7/12.30	517	63	400	1	0	10.6	81	317	0	0999	3	1548	721	85	99999	1121*	10	00	11	00	100	100	00110	10011*	0	00000	00000		
10/ 7/15.30	517	63	400	1	0	10.3	80	349	0	1548	2	1548	721	85	99999	1122*	10	00	11	00	100	111	00110	10011*	0	00000	00000		
10/ 7/18.30	517	63	380	1	0	10.0	81	321	0	1548	1	2047	721	85	99999	1123*	10	00	11	00	100	100	00110	10011*	0	00000	00000		
10/ 7/21.30	517	99	9999	1	0	9999	9	999	9	9999	0	1548	1	1548	721	85	14192	1124*	10	00	11	00	100	111	00110	10011*	0	00000	00000
10/ 7/24.30	517	63	400	1	0	9.3	81	294	0	1548	1	1548	721	85	99999	1125*	10	00	11	00	100	100	00110	10011*	0	00000	00000		
10/ 7/27.30	517	99	9999	1	0	9999	9	999	9	9999	0	1548	1	2047	721	85	99999	1126*	10	00	11	00	100	111	00110	10011*	0	00000	00000
10/ 7/30.30	517	99	9999	1	0	9999	9	999	9	9999	0	1548	1	2047	721	85	14191	1127*	10	00	11	00	100	111	00110	10011*	0	00000	00000
10/ 7/33.30	517	99	9999	1	0	9999	9	999	9	9999	0	1548	1	1548	721	85	14191	1128*	10	00	11	00	100	100	00110	10011*	0	00000	00000
10/ 7/36.30	517	63	0	1	0	8.0	80	301	0	1548	2	1548	721	85	14194	1129*	10	00	11	00	100	111	00110	10011*	0	00000	00000		
10/ 7/39.30	517	63	320	1	0	7.7	80	290	0	0999	2	1548	721	85	14192	1130*	10	00	11	00	100	100	00110	10011*	0	00000	00000		
10/ 7/42.30	517	63	420	1	0	7.4	81	353	0	1548	1	2047	721	85	99999	1131*	10	00	11	00	100	100	00110	10011*	0	00000	00000		
10/ 7/45.30	517	63	380	1	0	7.1	81	294	0	0999	1	2047	721	85	99999	1132*	10	00	11	00	100	110	00110	10011*	0	00000	00000		
10/ 7/48.30	517	63	400	1	0	6.8	81	321	0	1548	2	1548	721	85	14192	1133*	10	00	11	00	100	100	00110	10011*	0	00000	00000		
10/ 7/51.30	517	63	400	1	0	6.4	81	361	0	0999	1	1548	721	85	14192	1134*	10	00	11	00	100	101	00110	10011*	0	00000	00000		
10/ 7/54.30	517	63	420	1	0	6.1	81	319	0	1548	1	1548	721	85	99999	1135*	10	00	11	00	100	100	00110	10011*	0	00000	00000		
10/ 7/57.30	517	63	400	1	0	5.8	81	313	0	0999	1	2047	721	85	14192	1136*	10	00	11	00	100	111	00110	10011*	0	00000	00000		
10/ 8/ 0.30	517	63	400	1	0	5.4	80	329	0	1548	1	1548	721	85	14191	1138*	10	00	11	00	100	100	00110	10011*	0	00000	00000		
10/ 8/ 3.30	517	99	9999	1	0	9999	9	999	9	9999	0	1548	1	1548	721	85	99999	1139*	10	00	11	00	100	111	00110	10011*	0	00000	00000
10/ 8/ 6.30	517	63	300	1	0	4.9	80	354	0	1548	1	1548	721	85	99999	1140*	10	00	11	00	100	100	00110	10011*	0	00000	00000		
10/ 8/ 9.30	517	63	480	1	0	4.5	81	349	0	0999	2	1548	721	85	14194	1140*	10	00	11	00	100	111	00110	10011*	0	00000	00000		
10/ 8/12.30	517	63	440	1	0	4.2	80	297	0	1548	2	1548	721	85	99999	1141*	10	00	11	00	100	110	00110	10011*	0	00000	00000		
10/ 8/15.30	517	63	420	1	0	3.8	80	337	0	0999	3	1548	721	85	14192	1142*	10	00	11	00	100	111	00110	10011*	0	00000	00000		
10/ 8/18.30	517	63	400	1	0	3.5	80	341	0	1548	1	1548	721	85	14192	1143*	10	00	11	00	100	101	00110	10011*	0	00000	00000		
10/ 8/21.30	517	63	400	1	0	3.2	80	317	0	0999	1	1548	721	85	14192	1144*	10	00	11	00	100	101	00110	10011*	0	00000	00000		

BCD INPUT CAS CARD/MAG REDUCTION--COMMODOE FLT.15 6/3/74 DOUBLE DAISY  
 CAS 052-241-000 6-3-75 FLIGHT NO. 13 N377 N370  
 RUN NO. 2 SINDSV 75-180/255-180 N377HINI) N370CAL)

INPUT DATA FOR A/C 2 DATA RUN 2 PAGE 8

TIME	HR	MM	SEC	DMS	HI	DRDT	A	S	DMS	RNG	ALT	RNG/R	B	D	BDG	HI	SYNC	DMS	SRXIO	EPCH	SEL	ALT	RUN	ATC	FRS	HI
HR	MM	SEC	DMS	HI	DRDT	A	S	RNG	ALT	RNG/R	B	D	BDG	HI	SYNC	DMS	SRXIO	EPCH	SL	RG*AL	H*REA	QAG*QAZ48	ZACZ4*P	M*NC512	LD512	
10/ 8/24.30	517	63	400	1	0	2.8	80	337	0	1548	1	2047	721	85	99999	1145*	10	00	11	00	100	1				

B: redundant sign dR/dT.

O: indicates range rate was too great to display or be recorded.

BOGY: displays slot number for 1 epoch of any occupied slot in a roll call manner.

OWN AIRCRAFT SLOT (OMS) INFORMATION.

HI: own hierarchy information transmitted in the biphasic message.

Sync: the slot number transmitted in the biphasic message of the system which has been addressed for resync.

OMS: indicates own message slot number of the CAU or Mini-CAS.

XALT: the altitude transmitted in hundreds of feet.

RRX10<sup>-6</sup>: received resync indicates time in microseconds, relative to start of own slot, when resync was received. (Zero error sync reading = 1419.25).

EPCH: epoch number; increments by one count (once every 3 seconds). This time was zeroed out at the start of the flight and used as a backup to real time in correlating the CAS events.

SL, BG, AL, H: Status bit indicators of events (select, bogey mode, and altitude).

R: Status of dR/dT threat logic; "1" = ON.

E or ES: indicates epoch start triad, ground on air, received and verified. A or AR: indicates air resync triad received and verified.

O or OSC: indicates system is operating on internal oscillator (5 MHz) instead of external source (as FBS).

A or AS: antenna switch a "1" bit indicates ground epoch.

G or GR: indicates ground resync triad was received and verified.

ATC ATCRBS: the altitude code input to a CAU or Mini-CAS of the following bits (D<sub>4</sub>, A<sub>1</sub>, A<sub>2</sub>, A<sub>4</sub>, B<sub>1</sub>, B<sub>2</sub>, B<sub>4</sub>, C<sub>1</sub>, C<sub>2</sub>, and C<sub>4</sub>).

F: Fly-by sync indicates operation in the FBS mode (Not used in evaluation).

MI: Maneuver indicator threat status for CAU and partial threat for a Mini-CAS. (Status indications are N, C, 500, 1,000, 2000, L, D, 500, 1,000, 2,000).

A typical computer printout is shown in figure 6-19. This input data from A/C 1 (N377) was recorded during run 1 of flight 15. From this printout, it can be seen that the run was started at epoch 950. With A/C 1 (N377) in OMS 517, its real time clock was indicating 09:58:39.2, and 204 time slots away (204 X 1.5 ms = 306 ms), A/C 2 (N376) was in OMS 721. A data printout of

A/C (N377), shown in figure 6-20, does verify the computed slot of 09:58:39.5 for epoch 950 on A/C 2. This method of correcting each aircraft slot time to the corresponding epoch number was one method used to correlate data from all systems in a particular flight. A similar technique was employed when using tape-to-tape correlation; it resulted in the same type of slot time correction.

In examining the slot check feature, a flight of a CAU versus a Mini-CAS was chosen. The CAU does what is called a future slot check, where transmission of data messages are inhibited in its present active slot (OMS) and retransmitted in a future slot (OMS +4). The Mini-CAS does a coslot test, where it inhibits its altitude pulse transmission for one epoch.

Viewing the A/C 1 Mini-CAS printout in the before Tau 2 zone, from epoch 950 to 986, it can be seen that data (a blank field indicated by a 9) messages are missing at epoch 960, 971, and 977. In reviewing the corresponding printout of A/C 2, going vertically down the OMS column, the OMS number increases to 724 at both epoch 960 and 971. These two epochs are where the CAU withheld its present slot transmission and transmitted in the future slot. This resulted in a loss of data message, in the Mini-CAS-equipped aircraft. The missing data messages in epoch 977 resulted in a communication failure at the Mini-CAS end. Using the same procedure, by viewing figure 6-20, A/C 2 input data printout it can see that epoch 957 and 970 contain blank message data (range, altitude, etc.). Examining the corresponding printout for A/C 1, suppression of the altitude pulse transmission is apparent in own message for these epochs. A verification of the two epochs indicates that rather than a communication failure, a slot check was being performed. There were no failures in the before Tau 2 zone aboard A/C 2. The sample printouts of figure 6-20 indicate a high reliability for this run.

A summary of the percentage of completions before Tau 2, Tau 2 and Tau 1, and overall are found in figure 6-21. This sample printout illustrates how the air-to-air link communications reliability was computed for each aircraft.

Approximately 80 percent of the reduction was under program computer control. Where redundant data existed, or an epoch was considered questionable, they were deleted from any reliability computation. Manual program restart was used to overcome the obvious errors. The following are descriptions of each column and line on the sample Com Mod printout. Other details are furnished in order to understand the operation.

1. BCD Input CAS Card/Mag indicates the input data originated from card (data extracted from instrumentation photopanel) and then was transferred to magnetic tape.
2. Com Mod in the program used for the range and reliability analysis.
3. Flight Number is the number assigned to flight. Date: the day flight was flown.
4. Type of Flight indicates pattern type.

# BEST AVAILABLE COPY

BCD INPUT CAS CARD/MAG REDUCTION--COMMODORE FLT. 15 6/3/75 DOUBLE DAISY SINGLE DAISY										PAGE	9
RUN NO. ( 180.0 DEG.)		RUN NO. ( 180.0 DEG.)		RUN NO. ( 180.0 DEG.)		RUNS BEFORE		1/2 ( 180.0 DEG.)			
TAU 1	TAU 2	TAU 1	TAU 2	TAU 1	TAU 2	TAU 1	TAU 2	TAU 1	TAU 2	TAU 1	TAU 2
950	987	998	1099	1136	1146						
986	997	1006	1135	1145	1153						
37	11	0	20	57	37	10	8	18	55	74	21
0	0	0	0	0	0	0	0	0	0	0	0
37	11	0	20	57	37	10	8	18	55	74	21
-2	-1	0	-1	-3	-2	0	0	0	-2	-4	-1
35	10	0	12	54	35	10	8	18	53	70	20
3	1	0	1	4	2	0	0	0	2	5	1
0	0	0	0	0	0	0	0	0	0	0	0
-2	-1	0	-1	-3	-2	0	0	0	-2	-4	-1
1	0	0	0	1	0	0	0	0	0	1	0
34	10	0	19	53	35	10	8	14	53	69	20
97.1	100.0	100.0	100.0	90.1	100.0	100.0	100.0	100.0	100.0	91.0	100.0
EPOCH START	950	FND	1006	EPOCH START	1099	EPOCH	1153				
RANGE START	15.7			RANGE START	17.0						

76-23-6-21

FIGURE 6-21. COMMUNICATIONS RELIABILITY RUN OUTPUT DATA N377 (MINI-CAS)

5. Run No. gives run number identification.
6. Degree indicates the angle between radials in degrees of one aircraft with respect to the other.
7. Epoch at Start establishes initial track communication at this epoch. Epoch's along with time of day was used to correlate data from all systems (air and ground).
8. Epoch at End is where the closest approach range occurred, approximately 0.25 nmi.
9. Total No. Epochs is the number of epoch occurrences in that run.
10. Epochs not Recorded are epoch's considered questionable or from instrumentation failure that were not processed.
11. Epochs Recorded are the revised epoch chance total.
12. Slot Checks by Other System is slot checking by other aircraft where transmission of slot information is suppressed. No slot checking is permitted during a Tau 2 or Tau 1 situation.
13. Communication Chances indicate the maximum possible number of chances from the start of the run.
14. Missed Range Receptions are range transmission pulses not received.
15. Range OK Missed Range/Altitude are range pulses received, but altitude pulses were missing. Aircraft are in Tau zone, no computation of threat by onboard system.
16. Slot Checks by other System are same as used here to get corrected reception value. CAU does future slot checking where transmission of data messages are inhibited in active slot and retransmitted in future slot. Mini-CAS does coslot checking, where it inhibits altitude pulse transmission.
17. Total Missed Range/Altitude. Range/Altitude are tested for the same time occurrence. Data not in alignment are communication failures and are subtracted.
18. Total Complete Receptions for that run number.
19. Com. Rel B/A X 100 is communication reliability for a run, for one aircraft.
20. Communication's Range establishes a successful link with two chances in a row.

21. Communications reliability percentage was computed for the following:
- a. Before Tau 2: data computed after the initial turn in at the start of each new run until Tau 2 point.
  - b. Tau 2: data value computed from Tau 2 initiation until Tau 1.
  - c. Tau 1: data value computed from Tau 1 to crossover point (closest approach).
  - d. Tau 1, Tau 2: combination of both.
  - e. All: overall communications reliability for the total run.

The totaled statistical summary of communications reliability percent was computed for each run/flight/aircraft and recorded in table 6-2.

Additional information on the total number of air-to-air chances are found in the synchronization section of this chapter.

A summary of the air-to-air communications reliability for the CAU's was above 95 percent, and above 98 percent for the Mini-CAS. For the combination of a CAU versus a Mini-CAS, this value was above 92 percent. A breakdown of the communications in summary form is found in chapter 5.

#### COMMUNICATIONS SYNCHRONIZATION RELIABILITY AND ACCURACY.

SYNCHRONIZATION. Synchronization can be divided into two parts:

1. The process of obtaining synchronization (sync) to participate in the CAS environment, and
2. The process of responding to direct and general requests for sync from other participants.

The system provides for 2,000 time slots which occur at the rate of one every 1,500  $\mu$ s. These time slots reappear once every 3 seconds and are called epochs. Being that the T/F CAS is a time-ordered system, it is necessary that all participants be synchronized from a common time source. This time source can be either a ground station or another CAU that has an order of hierarchy higher than the requestor.

A ground station, on reception of a CAS transmission, treats it as a sync request in the odd epoch. The ground station initiates a reply which is recognized by the CAU triad decoding logic, and a comparison is made with the OMS time. From this comparison, a correction is made to the sync slot time.

In performing synchronization with another airborne system, the sync reply logic receives the addressing slot of each sync request. This address slot is compared with the OMS, and when correlation occurs, the sync reply is initiated. An error correction is then made to the message slot. A lower

TABLE 6-2. RF COMMUNICATIONS RELIABILITY PERCENT OF COMMUNICATIONS, AIR-AIR

Flight Number	A/C 1 (CAU)			A/C 2 (CAU)			All
	Before Tau 2	Tau 2	Tau 1	Before Tau 2	Tau 2	Tau 1	
20	96.48	99.49	99.49	97.26	99.58	100	99.76
23	98.81	99.89	100	99.38	99.51	100	99.76
26	98.57	99.85	100	99.08	98.81	100	99.39
8	95.44	95.14	96.70	95.87	93.96	100	97.52
41	96.01	99.43	97.98	97.71	98.8	96.4	97.7
46	Data not processable						
27							
29							
30							
57	91.91	99.54	97.88	93.97	100	96.5	98.2
19	95.18	100	100	97.04	98.23	99.51	98.71
43	99.5	99.3	100	99.5	100	100	100
48	93.24	94.89	98.98	93.99	91.83	100	97.23
49	97.6	99.4	100	98.5	99.4	100	99.6
50	94.6	100	100	96.9	100	100	100
10	63.75	100	100	70.08	97.34	95.89	96.82
11	92.46	95.71	98.98	93.44	95.58	100	96.38
12	96.93	99.63	100	99.75	99.38	97.40	98.79
13	99.01	98.53	100	99.04	98.18	99.52	98.68
14	94.61	98.84	100	99.31	93.77	99.28	98.49
15	95.4	100	100	97.0	91.3	100	94.3
16	95.5	99.0	100	97.5	95.2	100	97.8
* 99	96.0	92.1	84.7	92.8	92.86	84.21	89.53
31	A/C 3	N42	Tape	Was	Rad	A/C 2 (Mini-CAS)	
32	96.1	100	93.8	97	96.3	95.9	94.5
36	89.1	68.4	51.1	63.6	80.5	97.8	99.4
38	86.9	82.0	79.8	81.5	85.0	85.7	86.6
38	80.6	80.1	61.0	74.5	79.4	82.0	78.6
						In bogey mode	46.3
						35.0	78.1

The limited-level system, lacking biphasic, processes every message as a sync request in even epochs (in odd epochs, both full and limited level system receive ground replies). Although, the limited system does not provide for synchronization, it recognizes the ground and air starts and sync replies as in a full system.

This section of the report will provide information on synchronization accuracy and the reliability value when responding to other participants.

SYNCHRONIZATION ACCURACY. On synchronization accuracy, the airborne equipment shall be accurate to  $\pm 0.25$   $\mu\text{s}$  with respect to the sync donor with a probability of .995 as shown in the ACAS message format (figure 6-22, note 5). Upon receiving a synchronization request at time  $T_R$  relative to donor  $T_O$ , the synchronization donor shall transmit its synchronization reply at  $1404.2$  minus  $T_R$   $\mu\text{s}$  relative to donor  $T_O$ , with an accuracy of  $0.35$   $\mu\text{s}$ ;  $0.995$  probability. (The effect at the sync requestor is the one-way travel time, or  $\pm 0.17$   $\mu\text{s}$ .)

A sample copy of the statistical printout is shown in figure 6-23 for run 1 and figure 6-24 for run 2. This printout shows the numerical count and percentage weight around the no-correction time. The deadband (no correction) sync time  $t_S$  of  $1419.2$ - $1419.3$   $\mu\text{s}$  was displayed to the instrumentation (photopanel or magnetic tape) from the CAS equipment, and recorded during each epoch. When recording on magnetic tape through the tape interface unit, it was necessary, through a program option, to realign the no correction time. This time ( $t_S$ ) occurs at the leading edge of the synchronization triplet as shown in the CAS format. In processing the data, assuming the mean of a large number of random samples would be  $1419.25$   $\mu\text{s}$ , and assuming normal (Gaussian) distribution, the mean and standard deviation were computed using a corrected  $t_S$  of  $1419.25$   $\mu\text{s}$ . Other data from the distribution, such as maximum and minimum dispersion, provide an indication of the oscillator stability during the test period.

A sample listing of the input data that were transferred from punchcard to tape for run 1 and 2 of flight 15 are found in figures 6-19 and 6-20. The COM Mod program utilized the BCD input CARD/MAG reduction routine with separate option control for also outputting the communication range and reliability in addition to the syncro statistics.

The majority of all flight data, whether photopanel or magnetic tape derived, were processed by computer program control. Where problems occurred either on tape or film, manual "eyeball" processing was employed, and final statistical values determined by slide rule calculators.

A summary of the sync distribution (accuracy) of the equipments is given in table 6-3, CAU vs. CAU COM Synchronization (table 6-4) Mini-CAS vs. Mini-CAS COM Synchronization, (table 6-5) CAU vs. Mini-CAS COM Synchronization. No attempt was made to distinguish between the ground epoch (unaddressed syncs) and air epoch (addressed syncs) transmitted by the ground station and processed by the CAU's. However, this ground and air epoch comparison was made in Communication Sync Reliability.





BEST AVAILABLE COPY

BCO INPUT CAS CARD/MAG REDUCTION--SYNCRD FLT.15 6/3/75 SINGLE DAISY  
 CAS 052-241-000 6-3-75 FLIGHT NO. 15 N377 N376  
 RUN NO. 1 SINDSY 270-180/ 90-180 N377\*INIT) N376CAU)  
 RUN 1

SYNCHRONIZATION DATA FOR RUN TIME VALUES IN MICROSECONDS DIFFERENCE= PANEL VALUE LESS NOMINAL VALUE PAGE 1

VALUE	A/C1		A/C2		A/C3		RUN	
	COUNT	PERCENT	COUNT	PERCENT	COUNT	PERCENT	COUNT	PERCENT
OVER	0	0.0	0	0.0	0	0.0	0	0.0
1419.73	0	0.0	0	0.0	0	0.0	0	0.0
1419.85	3	8.82	0	0.0	0	0.0	3	2.68
1419.93	3	8.82	0	0.0	0	0.0	3	2.68
1419.45	7	20.59	14	17.95	0	0.0	21	18.75
1419.35	15	45.12	11	14.10	0	0.0	26	23.21
1419.25	6	17.65	39	50.00	0	0.0	45	40.18
1419.15	0	0.0	14	17.95	0	0.0	14	12.50
1419.05	0	0.0	0	0.0	0	0.0	0	0.0
1418.95	0	0.0	0	0.0	0	0.0	0	0.0
1418.85	0	0.0	0	0.0	0	0.0	0	0.0
1418.75	0	0.0	0	0.0	0	0.0	0	0.0
UNDER	0	0.0	0	0.0	0	0.0	0	0.0
TOTAL NON-BLANK	34		78		0		112	
TOTAL BLANK	104		60		0		164	

6-43

PBS MODE	0
PBS FAIL	34
PBS FAIL ONLY	34
PBS MODE/FAIL	0

DIFFERENCE STATISTICS IN UNITS OF MICROSECONDS

MAXIMUM	0.3500	0.0	0.3500
MINIMUM	-0.0500	0.0	-0.1500
RANGE	0.4000	0.0	0.5000
MEAN	0.09706	0.0	0.01696
SIGMA	0.11609	0.0	0.11577

76-23-6-23

FIGURE 6-23. SAMPLE LISTING OF SYNCHRONIZATION DIFFERENCE STATISTICS (RUN 1)

BEST AVAILABLE COPY

BCD INPUT CAS CARD/MAG REDUCTION--SYNCRD FLT. 15 6/3/75 SINGLE DAISY  
 CAS 088-241-000 6-3-75 FLIGHT NO. 15 N377 N376  
 RUN NO. 2 SINDSY 75-100/255-100 N377MINI N376CAUJ  
 RUN 2

SYNCHRONIZATION DATA FOR RUN TIME VALUES IN MICROSECONDS DIFFERENCE= PANEL VALUE LESS NOMINAL VALUE PAGE 2

VALUE	COUNT	A/C1	PERCENT	COUNT	A/C2	PERCENT	COUNT	A/C3	PERCENT	COUNT	PERCENT
OVER	0	0	0.	0	0	0.	0	0	0.	0	0.
1419.73	0	0	0.	0	0	0.	0	0	0.	0	0.
1419.65	3	3	5.08	0	0	0.	0	0	0.	3	2.14
1419.55	12	12	20.34	0	0	0.	0	0	0.	12	8.57
1419.45	0	0	0.	0	0	0.	0	0	0.	20	14.29
1419.35	11	11	18.64	9	11.11	0.	0	0	0.	21	15.00
1419.25	17	17	28.81	4	4.94	0.	0	0	0.	73	52.14
1419.15	14	14	23.73	59	72.84	0.	0	0	0.	11	7.86
1419.05	2	2	3.39	0	0	0.	0	0	0.	0	0.
1418.95	0	0	0.	0	0	0.	0	0	0.	0	0.
1418.85	0	0	0.	0	0	0.	0	0	0.	0	0.
1418.75	0	0	0.	0	0	0.	0	0	0.	0	0.
UNDER	0	0	0.	0	0	0.	0	0	0.	0	0.
TOTAL NON-BLANK	59			81			0			140	
TOTAL BLANK	72			50			0			122	
FBS MODE	0			0			0			0	
FBS FAIL	59			81			0			140	
FBS FAIL ONLY	59			81			0			140	
FBS MODE/FAIL	0			0			0			0	

DIFFERENCE STATISTICS IN UNITS OF MICROSECONDS	
MAXIMUM	0.3500
MINIMUM	-0.1500
RANGE	0.5000
MEAN	0.09407
STGMA	0.12902
	0.1500
	-0.1500
	0.3000
	-0.03395
	0.07658
	0.
	0.
	0.
	0.
	0.3500
	-0.1500
	0.5000
	0.02000
	0.11977

76-23-6-24

FIGURE 6-24. SAMPLE LISTING OF SYNCHRONIZATION DIFFERENCE STATISTICS (RUN 2)

TABLE 6-3. COM SYNCHRONIZATION ACCURACY (CAU VS. CAU)

A/C 1 CAU Vs. A/C 2 CAU

<u>Flight Number</u>	<u>Maximum (<math>\mu</math>s)</u>	<u>Minimum (<math>\mu</math>s)</u>	<u>Range (<math>\mu</math>s)</u>	<u>Mean (<math>\mu</math>s)</u>	<u>Sigma (<math>\mu</math>s)</u>
8	0.25	-0.25	0.50	-0.0269	0.1377
20	0.35	-0.25	0.60	- .0056	.0949
23	0.25	0.25	0.50	.0040	.0984
26	0.35	0.35	0.70	.0088	.1097
41	0.25	-0.15	0.40	.0008	.1036
57	0.55	-0.35	0.90	.0167	.0861

A/C 2 CAU Vs. A/C 1 CAU

8	0.25	-0.15	0.40	-0.0269	0.0912
20	0.45	-0.25	0.70	- .0097	.0912
23	0.35	-0.25	0.60	- .0080	.0887
26	0.35	-0.15	0.50	- .0211	.0754
41	0.25	-0.05	0.30	.0889	.0892
57	0.35	-0.25	0.60	.0993	.0879

TABLE 6-4. COM SYNCHRONIZATION ACCURACY (MINI-CAS VS. MINI-CAS)

A/C 1 Mini-CAS Vs. A/C 2 Mini-CAS

<u>Flight Number</u>	<u>Maximum (<math>\mu</math>s)</u>	<u>Minimum (<math>\mu</math>s)</u>	<u>Range (<math>\mu</math>s)</u>	<u>Mean (<math>\mu</math>s)</u>	<u>Sigma (<math>\mu</math>s)</u>
* 19	0.35	-0.35	0.70	0.0982	0.1035
43	0.25	-0.15	0.40	.0952	.0882
48	0.35	-0.05	0.40	.0938	.0816
49	0.25	-0.15	0.40	.0904	.0940
50	0.25	-0.25	0.50	.0954	.0740
4	0.45	-0.15	0.60	.1084	.0897
5	0.35	-0.25	0.60	.0935	.0910

A/C 2 Mini-CAS Vs. A/C 1 Mini-CAS

* 19	0.45	-0.35	0.80	-0.0008	0.0933
43	0.25	-0.15	0.40	.0860	.0733
48	0.35	-0.15	0.50	.1044	.0923
49	0.25	-0.15	0.40	.1043	.0670
50	0.25	-0.15	0.40	.0976	.0858
* 4	0.25	-0.25	0.50	-.0026	.0864
* 5	0.15	0.25	0.40	-.008	.0819

\* Local ACY flight over NAFEC instrument range and CAS ground station.

TABLE 6-5. COM SYNCHRONIZATION ACCURACY (MINI-CAS VS. CAU)

A/C 1 Mini-CAS Vs. A/C 2 CAU

<u>Flight Number</u>	<u>Maximum (<math>\mu</math>s)</u>	<u>Minimum (<math>\mu</math>s)</u>	<u>Range (<math>\mu</math>s)</u>	<u>Mean (<math>\mu</math>s)</u>	<u>Sigma (<math>\mu</math>s)</u>
9	0.50	-0.75	1.25	0.0645	0.1443
10	0.75	-0.55	1.30	.0992	.1208
11	0.45	-0.35	0.80	.0100	.1051
12	0.55	-0.25	0.80	.0919	.1331
13	0.65	-0.45	1.10	.1035	.1303
14	0.55	-0.25	0.80	.0995	.1163
15	0.45	-0.15	0.60	.1061	.1283
16	0.55	-0.25	0.80	.0923	.1277

A/C 2 CAU Vs. A/C Mini-CAS

9	0.65	-0.15	0.80	0.0081	0.0980
10	0.35	-0.25	0.60	-.1380	.0785
11	0.15	-0.25	0.40	.0101	.0694
12	0.25	-0.25	0.50	-.0170	.0844
13	0.25	-0.15	0.40	.0095	.0966
14	0.25	-0.25	0.50	-.0008	.0993
15	0.55	-0.15	0.70	-.0282	.0878
16	0.25	-0.25	0.50	-.0177	.0869

The CAU requires a resync every 6 seconds (within the 0.2- $\mu$ s deadband, to remain in hierarchy 1.) It can remain in sync mode, demoting to hierarchy 40, in the absence of any sync for 4 minutes. While Mini-CAS is designed to operate for 3.2 minutes in the absence of a resync.

COMMUNICATIONS SYNCHRONIZATION RELIABILITY. As indicated earlier, in order to participate in the CAS community, it is necessary to initially obtain a sync and process as many resync updates as possible. Although a resync link reliability as low as 50 percent would result in an average update rate of one resync every 12 seconds.

Discussion in this section will be on the number of chances versus the number of receptions made for the same flights flown earlier in this chapter. All coslot checks and nonrecorded epochs were excluded from these numbers.

Tables 6-6, 6-7, and 6-8 are a summary of (each aircraft-equipment) communication synchronization reliability. In processing this data, the following considerations are presented for each configuration:

1. CAU versus CAU--the possible communication chances for a CAU are 100 percent of the ground epoch transmissions and (40 to 60 percent) of the air epochs. (CAU addresses ground for a sync in air epoch with a 0.5 probability.)



TABLE 6-7. COM SYNC RELIABILITY PERCENT RECEPTIONS GROUND-AIR (MINI-CAS VS. MINI-CAS)

A/C 1 Mini-CAS Vs. A/C 2 Mini-CAS											
Flight Number	Ground		Air		Air		Percent		Total		Total Percent
	Chances	Receptions	Chances	Receptions	Chances	Receptions	Percent	Percent	Chances	Receptions	
* 4	607	469	-	-	-	-	-	-	607	469	77.26
* 5	682	492	-	-	-	-	-	-	682	492	72.14
19	1185	479	-	-	-	-	-	-	1185	479	40.42
43	1192	1124	-	-	-	-	-	-	1192	1124	94.29
48	1639	1156	-	-	-	-	-	-	1639	1556	94.94
49	823	786	-	-	-	-	-	-	823	786	95.50
50	827	781	-	-	-	-	-	-	827	781	94.44
A/C 2 Mini-CAS Vs. A/C 1 Mini-CAS											
* 4	607	492	-	-	-	-	-	-	607	492	81.05
* 5	682	531	-	-	-	-	-	-	682	531	77.86
*19	1185	565	-	-	-	-	-	-	1185	565	47.68
*43	1192	1122	-	-	-	-	-	-	1192	1122	94.13
48	1752	1652	-	-	-	-	-	-	1752	1652	94.29
49	1049	997	-	-	-	-	-	-	1049	997	95.04
50	998	938	-	-	-	-	-	-	998	938	93.98

\* Local ACY flight over NAFEC instruction range and CAS ground station.

TABLE 6-8. COM SYNC RELIABILITY PERCENT RECEPTIONS GROUND-AIR (MINI-CAS VS. CAU)

A/C 1 Mini-CAS Vs. A/C 2 CAU

Flight Number	Ground		Air		Air		Air		Total	
	Chances	Receptions	Percent	Chances	Receptions	Percent	Chances	Receptions	Chances	Percent
9	1401	1144	81.66	517	353	68.28	1918	1497	78.05	
10	1169	974	83.32	390	327	83.85	1559	1301	83.45	
11	1005	755	75.12	403	282	69.97	1408	1037	73.65	
12	728	618	84.89	314	187	59.55	1042	805	77.25	
13	1035	931	89.95	480	199	41.46	1515	1130	74.58	
14	1131	957	84.62	485	338	69.69	1616	1295	80.13	
15	319	158	49.53	102	79	77.45	421	237	56.29	
16	1100	926	84.18	467	299	64.03	1567	1225	78.17	

A/C 2 CAU Vs. A/C 1 Mini-CAS

9	1401	1374	98.07	682	604	88.56	2083	1978	94.96	
10	1169	1138	97.35	559	542	96.96	1697	1649	97.17	
11	1005	957	95.22	493	488	98.98	1498	1445	96.46	
12	728	693	95.19	346	329	95.08	1074	1022	95.16	
13	1035	969	93.62	490	469	95.71	1525	1438	94.29	
14	1131	1083	95.76	529	512	96.78	1660	1595	96.08	
15	319	291	91.22	142	99	69.72	461	390	84.59	
16	1100	1074	97.64	536	527	98.32	1636	1601	97.86	

2. Mini-CAS versus Mini-CAS--the possible communication chances for a Mini-CAS are all the ground epochs only.

Example: 100 epoch total  
50 ground epochs

The maximum chances for this case are 50 ground epochs.

3. Mini-CAS versus CAU--the possible communication chances for the Mini-CAS are all the ground epochs and 40 to 60 percent of the air epochs.

Example: 100 epoch total  
50 ground epochs  
50 air epochs

Mini-CAS possible chances are all the ground epochs and 40 to 60 percent of the air epochs. Mini-CAS air epochs are reserved for discrete address sync by the CAU hierarchial sync scheme, and for 1/N-type air-to-air sync of limited systems by full systems. The final test results for the communications synchronization reliability are shown in chapter 5.

## CHAPTER 7

### RANGE, RANGE RATE, AND WARNING-TIME ACCURACY

#### INTRODUCTION.

A summary of the accuracy tests performed is given in table 7-1. As indicated in this table, there were two Mini-CAS equipments and two CAU equipments tested. The two-aircraft encounters were flown using two Gulfstreams, N377 and N376. The Convair 880 Jet, N42, was used with the Gulfstreams for the three-aircraft encounters. The tests, which took place within a 10-nmi radius of NAFEC, examined various types of maneuvers or patterns. These included head-on, tail-chase, parallel, and  $15^\circ/30^\circ/90^\circ$  closures. In some cases, the maneuvers were repeated at different headings and rates of closure. Specific flight data are given in chapter 4. It should be noted that during these tests, the pilots were asked to ignore the maneuver indicator advisories and commands and continue flying the prescribed pattern.

The positions of the aircraft were measured by the phototheodolites and the EAIR. There are four phototheodolite stations at NAFEC. A minimum of two stations are required to measure the position of one aircraft. For the two-aircraft encounters, two stations were used for each aircraft with EAIR also being used for one of the aircraft. For the three-aircraft encounters, phototheodolites were used for two aircraft and EAIR for the third aircraft.

As indicated in chapter 2, the CAS outputs and real time (to the nearest millisecond) were recorded every epoch on a photopanel and, later on, also on magnetic tape. In the case of the photopanel data, pictures were taken at a predetermined time during the epoch. These pictures were read, and the data contained on them were transferred to punchcard. For each aircraft, the cards were assembled by flight and then by run and put on magnetic tape. A sample copy of this tape printout is shown in figure 7-1. In the case of the data recorded directly on magnetic tape in the aircraft, a different tape was generated for each flight and file marks were used to identify the runs. A sample copy of this tape printout is shown in figure 2-21. Again, it should be noted that the CAS equipments do not compute range directly. Clock pulses are counted with the number counted being a function of the range between the two aircraft but no range is derived. Only range rate, based on the difference in clock counts over 6 seconds or 3 seconds, is directly computed by CAS. The range data discussed in this report were actually computed by the aircraft instrumentation using the same inputs that the CAS receives.

The angular position data from each of the tracking phototheodolite stations, along with real time, were recorded on magnetic tape at the rate of 20 points per second. Film data were also taken at each phototheodolite station for backup purposes. The EAIR data, including real time, slant range, azimuth, and elevation angles, were recorded on magnetic tape every 0.1 seconds. Both the phototheodolite and EAIR data were then rotated and translated to building 156 at NAFEC to provide a common reference using available reduction software in the NAFEC 7090 computer library. For each flight, binary tapes, containing

TABLE 7-1. SUMMARY OF THE ACCURACY TESTS PERFORMED

Flight No.	Flight Date	CAS Equipment		Measurement System		CAS Instrumentation		
		N377	N376	N377	N376	N377	N376	N42
1	1-28-75	Mini-2	CAU-2	Theo.	EAP	Photo.	Photo.	
2	1-30-75	Mini-2	CAU-2	Theo.	EAP	Photo.	Photo.	
3	2-3-75	Mini-2	CAU-2	Theo.	EAP	Photo.	Photo.	
4	2-14-75	Mini-2	Mini-1	Theo.	FAIR	Photo.	Photo.	
5	2-28-75	Mini-2	Mini-1	Theo.	FAIR	Photo.	Photo.	
6	3-6-75	CAU-1	CAU-2	Theo.	EAP	Photo.	Photo.	
7	4-1-75	CAU-1	CAU-2	Theo.	Theo.	Photo.	Photo.	
17	6-9-75	Mini-2	CAU-2	Theo.	Theo.	Photo.	Photo.	
18	6-10-75	Mini-2	CAU-2	Theo.	Theo.	Photo.	Photo.	
25	6-23-75	CAU-1	CAU-2	Theo.	Theo.	Photo.	Photo.	
34	7-23-75	CAU-1	Mini-1	FAIR	Theo.	Photo.	Photo.	Tape
35	7-24-75	CAU-1	Mini-1	FAIR	Theo.	Photo.	Photo.	Tape
39	7-30-75	CAU-1	Mini-1	FAIR	Theo.	Photo.	Photo.	Tape
40	7-31-75	CAU-1	Mini-1	EAP	Theo.	Photo.	Photo.	Tape
59	9-30-75	CAU-1	Mini-1	EAP	Theo.	Tape	Photo.	Tape
60	10-3-75	CAU-1	Mini-1	FAIR	Theo.	Tape	Photo.	Tape

TIME	DMS	HKA	RAT	ASX	RNG	ALT	RR	B	BOY	WHIR	SYC	U'S	DMS	ALT	RE-SYM	EPCH	SLESR	DA4A8BCC	TC12LD512	8BY	DSC	AS	GR	SERIAL
10/ 4/49.3	673	0	100	10	47	30	-0	0	1548	*	0	0	85	32	9999.9	754	1	00	0001100100	0000000000	0	0	0	2
10/ 4/52.3	673	0	100	10	47	29	-0	0	1740	*	0	0	85	31	1419.2	755	1	11	0001100100	0000000000	0	0	0	4
10/ 4/55.3	673	0	100	10	45	30	-0	0	9999.9	*	0	0	85	31	9999.9	756	1	00	0001100100	0000000000	0	0	0	6
10/ 4/58.3	673	0	100	10	44	29	-0	0	79	*	0	0	85	39	9999.9	757	1	10	0001100100	0000000000	0	0	0	8
10/ 5/ 1.3	673	0	100	10	42	30	-0	0	1548	*	0	0	85	31	9999.9	758	1	00	0001100100	0000000000	0	0	0	10
10/ 5/ 4.3	673	0	200	10	41	29	-0	0	1740	*	0	0	85	31	1419.2	759	1	11	0001100100	0000000000	0	0	0	12
10/ 5/ 7.3	673	0	200	10	39	29	-0	0	9999.9	*	0	0	85	31	9999.9	760	1	00	0001100100	0000000000	0	0	0	14
10/ 5/10.3	673	0	180	10	37	30	-0	0	79	*	0	0	85	31	1419.2	761	1	11	0001100100	0000000000	0	0	0	16
10/ 5/13.3	673	0	180	10	35	29	-0	0	1548	*	0	0	85	31	9999.9	762	1	00	0001100100	0000000000	0	0	0	18
10/ 5/16.3	673	0	200	10	34	29	-0	0	1740	*	0	0	85	31	1419.2	763	1	11	0001100100	0000000000	0	0	0	20
10/ 5/19.3	673	9	999	999	999	999	9999	9999	9999	*	0	0	85	31	9999.9	764	1	00	0001100100	0000000000	0	0	0	22
10/ 5/22.3	673	0	180	10	31	29	-0	0	79	*	0	0	85	31	1419.2	765	1	11	0001100100	0000000000	0	0	0	24
10/ 5/25.3	673	0	180	10	29	29	-0	0	1548	*	0	0	85	31	9999.9	766	1	00	0001100100	0000000000	0	0	0	26
10/ 5/28.3	673	0	180	10	29	30	-0	0	1740	*	0	0	85	31	1419.2	767	1	11	0001100100	0000000000	0	0	0	28
10/ 5/31.3	673	0	180	10	27	29	-0	0	9999.9	*	0	0	85	31	9999.9	768	1	00	0001100100	0000000000	0	0	0	30
10/ 5/34.3	673	0	180	10	27	29	-0	0	79	*	0	0	85	31	1419.2	769	1	11	0001100100	0000000000	0	0	0	32
10/ 5/37.3	673	0	160	10	23	29	-0	0	1548	*	0	0	85	31	9999.9	770	1	00	0001100100	0000000000	0	0	0	34
10/ 5/40.3	673	0	160	10	23	29	-0	0	1740	*	0	0	85	31	1419.2	771	1	00	0001100100	0000000000	0	0	0	36
10/ 5/43.3	673	0	180	10	21	29	-0	0	9999.9	*	0	0	85	31	9999.9	772	1	11	0001100100	0000000000	0	0	0	38
10/ 5/46.3	673	0	180	10	20	29	-0	0	79	*	0	0	85	39	9999.9	773	1	11	0001100100	0000000000	0	0	0	40
10/ 5/49.3	673	0	180	10	17	29	-0	0	1548	*	0	0	85	31	1419.2	774	1	11	0001100100	0000000000	0	0	0	42
10/ 5/52.3	673	9	999	999	999	999	9999	9999	9999	*	0	0	85	31	9999.9	775	1	11	0001100100	0000000000	0	0	0	44
10/ 5/55.3	673	0	180	10	14	29	-0	0	1740	*	0	0	85	31	1419.2	776	1	11	0001100100	0000000000	0	0	0	46
10/ 5/58.3	673	0	180	10	13	29	-0	0	9999.9	*	0	0	85	31	9999.9	777	1	11	0001100100	0000000000	0	0	0	48
10/ 5/ 1.3	673	0	160	10	13	29	-0	0	1548	*	0	0	85	31	1419.2	778	1	11	0001100100	0000000000	0	0	0	50
10/ 5/ 4.3	673	0	160	10	13	29	-0	0	1740	*	0	0	85	31	9999.9	779	1	11	0001100100	0000000000	0	0	0	52
10/ 5/ 7.3	673	0	180	10	13	29	-0	0	9999.9	*	0	0	85	31	1419.2	780	1	11	0001100100	0000000000	0	0	0	54
10/ 5/10.3	673	0	180	10	9	30	-0	0	79	*	0	0	85	31	1419.2	781	1	11	0001100100	0000000000	0	0	0	56
10/ 5/13.3	673	0	180	10	7	29	-0	0	9999.9	*	0	0	85	31	9999.9	782	1	00	0001100100	0000000000	0	0	0	58
10/ 5/16.3	673	0	160	10	5	29	-0	0	1548	*	0	0	85	31	1419.2	783	1	00	0001100100	0000000000	0	0	0	60
10/ 5/19.3	673	0	160	10	3	29	-0	0	1740	*	0	0	85	31	9999.9	784	1	00	0001100100	0000000000	0	0	0	62
10/ 5/22.3	673	0	160	10	3	29	-0	0	9999.9	*	0	0	85	31	1419.2	785	1	00	0001100100	0000000000	0	0	0	64
10/ 5/25.3	673	0	180	10	1	29	-0	0	1548	*	0	0	85	31	9999.9	786	1	11	0001100100	0000000000	0	0	0	66
10/ 5/28.3	673	0	120	10	1	29	-0	0	1740	*	0	0	85	31	1419.2	787	1	11	0001100100	0000000000	0	0	0	68
10/ 5/31.3	673	0	140	00	2	29	-0	0	9999.9	*	0	0	85	31	9999.9	788	1	00	0001100100	0000000000	0	0	0	70
10/ 5/34.3	673	0	140	00	3	29	-0	0	1548	*	0	0	85	31	1419.2	789	1	11	0001100100	0000000000	0	0	0	72
10/ 5/37.3	673	0	180	00	2	29	-0	0	1740	*	0	0	85	31	9999.9	790	1	00	0001100100	0000000000	0	0	0	74
10/ 5/40.3	673	0	160	00	2	29	-0	0	9999.9	*	0	0	85	31	1419.2	791	1	11	0001100100	0000000000	0	0	0	76
10/ 5/43.3	673	0	160	00	4	29	-0	0	1548	*	0	0	85	31	9999.9	792	1	00	0001100100	0000000000	0	0	0	78
10/ 5/46.3	673	0	180	00	9	30	-0	0	1740	*	0	0	85	31	1419.2	793	1	11	0001100100	0000000000	0	0	0	80
10/ 5/49.3	673	0	180	00	11	29	-0	0	9999.9	*	0	0	85	31	9999.9	794	1	00	0001100100	0000000000	0	0	0	82
10/ 5/52.3	673	5	999	999	999	999	9999	9999	9999	*	0	0	85	31	1419.2	795	1	11	0001100100	0000000000	0	0	0	84
10/ 5/55.3	673	0	180	00	14	29	-0	0	1548	*	0	0	85	32	9999.9	796	1	00	0001100100	0000000000	0	0	0	86
10/ 5/58.3	673	0	160	00	13	29	-0	0	1740	*	0	0	85	32	1419.2	797	1	11	0001100100	0000000000	0	0	0	88
10/ 7/ 1.3	673	0	160	00	10	29	-0	0	9999.9	*	0	0	85	32	9999.9	798	1	11	0001100100	0000000000	0	0	0	90
10/ 7/ 4.3	673	0	160	00	18	29	-0	0	1548	*	0	0	85	32	1419.2	799	1	11	0001100100	0000000000	0	0	0	92
10/ 7/ 7.3	673	0	160	00	19	29	-0	0	1740	*	0	0	85	32	9999.9	800	1	11	0001100100	0000000000	0	0	0	94
10/ 7/10.3	673	0	180	00	20	30	-0	0	9999.9	*	0	0	85	32	1419.2	801	1	11	0001100100	0000000000	0	0	0	96
10/ 7/13.3	673	0	180	00	21	30	-0	0	1548	*	0	0	85	32	9999.9	802	1	00	0001100100	0000000000	0	0	0	98
10/ 7/16.3	673	0	160	00	22	29	-0	0	1740	*	0	0	85	32	1419.2	803	1	11	0001100100	0000000000	0	0	0	100

76-23-7-1

FIGURE 7-1. A SAMPLE LISTING OF CAS PHOTOPANEL REDUCTION PROGRAM PRINTOUT

BEST AVAILABLE COPY

the x, y, and z data for each aircraft, were generated for follow-on analyses along with hard copy listings of the aircraft positions during each run. The processed phototheodolite data gave position measurements every 0.1 seconds. A description of the phototheodolite and EAIR reduction programs is given in reference 6.

A 7090 computer program was developed to merge, on a tape-to-tape basis, the CAS data, either photopanel or tape, with the measurement system or tracker data for both aircraft to provide CAS range and range rate errors. If CAS photopanel data are being merged, the program first corrects the CAS time to allow for the difference between the time that the picture was taken and the time that the CAS information was received. Using the CAS epoch time, the merge program searches the two tracker files for the times closest to this time. Slant range separation calculations are then made using the tracker data for this time and for the times within 0.5 seconds each side of it. A least squares quadratic was used to fit these 11 range points against time. The range selected for the analysis was computed by solving the quadratic equation using the CAS time. From these smoothed ranges, tracker range rates were calculated over the same time period that CAS used. Finally, for each epoch, tracker range and range rate were subtracted from CAS range and range rate to obtain CAS errors. A sample printout of these data is shown in figure 7-2. An asterisk appearing in column three of the printout indicates that range rates were calculated over 3 seconds instead of 6 seconds.

Also shown in figure 7-2 are CAS and tracker warning time calculations and the status of the maneuver indicator. This information was listed to assist in screening the warning time data. The procedures used to analyze CAS warning time accuracy are described later in this chapter.

#### RANGE AND RANGE RATE ACCURACIES.

The range and range rate accuracy analyses were based on data obtained from the first seven flights listed in table 7-1. A total of 9 Mini-CAS/CAU, 17 Mini-CAS/Mini-CAS, and 13 CAU/CAU runs were initially included in the analyses. A printout of the CAS/tracker merge program, such as that shown in figure 7-2, was generated for each aircraft or equipment and run. Only converging data were considered in the accuracy analyses, primarily, since range and range rate accuracies associated with diverging flightpaths do not impact CAS warning time accuracy. The range separations associated with the start and end of the runs varied with the type of maneuver flown. Head-on runs generally varied between 8-nmi and 0.2-nmi separations. For the other maneuver types, the separations generally varied between 5 nmi and 0.2 nmi. The closing range rates varied between 260 and 440 knots for the head-on runs, between 160 and 240 knots for the 90° closure runs, and between 0 and 120 knots for the remaining maneuvers. During any one particular run, the CAS closing range rates generally were within 20 knots of the nominal closing rate.

BEST AVAILABLE COPY

RUN 03 240709 13 578 2 28 75 8414 M35 N160 X201 N376  
 CAS 054-241-000 2728/75 FLIGHT NO. 3 N160 N376  
 RUN NO. 2 NO DEG CLOSURE (I/O KI METERS) N160(N161)

X	Y	TIME	SRG	CAS	RG	TRK	RG	DEL	RGE	CAS	RT	TRK	RT	DEL RT		CAS TAU		CAS TAU		MI	TRK	TAU	DEL	TAU
														KTS	KTS	SEC	SEC	SEC	SEC					
10	4	36.519	7	4.400	4.329	0.071	200	191.70	8.30	79.77	46.88	76.60	47.15	1.9	0.7									
10	4	39.519	9	4.200	4.174	0.026	200	193.08	6.92	71.11	44.14	73.21	44.3	2.8	1.1									
10	3	24.519	11	4.100	4.015	0.085	200	188.10	11.90	69.3	41.4	72.1	42.4	2.0	0.0									
10	5	5.519	13	3.900	3.663	0.037	200	186.41	18.59	65.7	37.8	69.8	39.8	2.0	0.0									
10	5	8.519	15	3.800	3.709	0.091	180	183.33	23.33	71.0	40.0	67.9	37.5	3.1	2.5									
10	5	11.519	17	3.600	3.554	0.046	180	184.52	24.52	67.0	36.0	64.5	34.3	2.5	1.7									
10	3	14.519	19	3.400	3.401	-0.001	200	185.29	14.71	56.7	28.8	61.2	31.1	-1.5	-1.3									
10	3	17.519	21	3.200	3.256	0.056	200	179.95	18.77	53.7	28.0	55.8	25.4	1.2	0.4									
10	3	20.519	23	3.100	3.025	0.075	180	183.57	23.57	50.0	26.0	53.8	24.2	1.2	0.6									
10	3	23.519	25	3.000	2.952	0.048	200	171.27	28.73	49.5	21.6	51.8	21.0	-1.3	-0.8									
10	3	26.519	27	2.800	2.807	-0.007	180	172.51	7.49	51.0	20.0	51.4	20.4	-1.0	-0.5									
10	3	29.519	29	2.700	2.663	0.037	180	173.48	6.52	49.0	18.0	50.1	17.9	-1.1	0.1									
10	3	32.519	31	2.500	2.519	-0.019	180	172.98	7.02	45.0	14.0	47.2	15.0	-2.2	-1.0									
10	3	35.519	33	2.400	2.370	0.030	160	175.99	-15.99	48.4	13.5	43.4	11.6	5.0	1.9									
10	3	38.519	35	2.300	2.228	0.072	160	174.45	-14.45	46.1	11.3	40.8	8.8	2.4	2.4									
10	3	41.519	37	2.100	2.066	0.034	180	170.45	9.95	37.0	6.0	38.9	6.1	-1.9	-0.1									
10	3	44.519	39	2.000	1.951	0.049	200	163.81	34.19	31.8	3.6	36.9	3.3	-3.4	0.3									
10	3	47.519	41	1.900	1.801	0.099	180	170.74	9.22	33.0	2.0	32.7	0.0	0.3	2.0									
10	3	50.519	43	1.700	1.690	0.010	180	174.97	5.03	29.0	-2.0	29.0	-1.9	0.0	0.9									
10	3	53.519	45	1.500	1.520	0.020	180	169.14	16.14	23.0	-8.0	24.3	-1.3	1.3	1.0									
10	3	56.519	47	1.300	1.331	0.031	180	167.59	12.41	23.0	-8.0	24.3	-1.3	1.3	1.0									
10	3	59.519	49	1.200	1.239	0.039	160	174.05	-14.05	23.4	-11.2	20.4	-1.7	0.6	0.6									
10	3	62.519	51	1.200	1.094	0.106	160	172.00	-12.00	21.4	-13.5	17.7	-11.8	3.7	1.3									
10	3	65.519	53	1.000	0.955	0.045	180	168.52	11.48	15.0	-13.5	15.1	-10.1	2.1	1.3									
10	3	68.519	55	0.900	0.816	0.084	180	166.60	13.40	13.0	-18.0	12.2	-21.3	0.8	3.3									
10	3	71.519	57	0.700	0.683	0.017	180	165.08	16.92	19.0	-22.0	9.6	-24.7	-0.6	2.7									
10	3	74.519	59	0.500	0.533	-0.033	200	168.60	31.40	11.0	-23.4	6.1	-27.0	-0.4	3.6									
10	3	77.519	61	0.400	0.404	-0.004	180	161.50	7.30	8.0	-31.5	3.0	-34.0	-1.3	1.3									
10	3	80.519	63	0.300	0.271	0.029	180	151.46	-17.46	3.0	-34.0	3.0	-37.0	-1.3	1.3									
10	3	83.519	65	0.100	0.31	-0.21	180	163.46	-13.46	3.0	-34.0	3.0	-37.0	-1.3	1.3									
10	3	86.519	67	0.100	0.44	0.34	120	137.18	-17.18	3.0	-34.0	3.0	-37.0	-1.3	1.3									
10	3	89.519	69	0.200	0.157	0.043	-40	-15.69	-2.31	3.0	-34.0	3.0	-37.0	-1.3	1.3									
10	3	92.519	71	0.300	0.501	-0.01	-140	-154.00	14.00	3.0	-34.0	3.0	-37.0	-1.3	1.3									
10	3	95.519	73	0.500	0.443	0.057	-180	-171.62	-16.38	3.0	-34.0	3.0	-37.0	-1.3	1.3									
10	3	98.519	75	0.600	0.278	0.022	-180	-166.23	-16.77	7.0	-24.0	7.1	-26.5	0.1	-1.4									
10	3	101.519	77	0.800	0.715	0.085	-160	-163.13	-9.13	12.4	-22.5	-10.3	-23.9	0.1	-1.4									
10	3	104.519	79	0.900	0.556	0.034	-180	-167.01	-15.99	13.0	-18.0	-13.1	-20.3	0.1	-2.3									
10	3	107.519	81	1.100	0.995	0.105	-180	-168.11	-15.89	13.0	-14.0	-16.0	-17.2	-1.0	-2.3									
10	3	110.519	83	1.400	1.274	0.126	-180	-166.16	-15.89	23.0	8.0	-22.1	-11.3	0.9	3.3									
10	3	113.519	85	1.500	1.408	0.092	-180	-161.09	-15.81	26.1	6.7	-25.8	-8.7	-2.0	2.0									
10	3	116.519	87	1.600	1.545	0.085	-160	-161.75	2.75	20.4	4.5	-28.6	-5.6	-0.7	-1.1									
10	3	119.519	89	1.800	1.684	0.134	-160	-163.70	3.70	20.6	-0.0	-31.5	-2.6	-1.9	-0.9									
10	3	122.519	91	1.900	1.817	0.083	-160	-163.21	2.21	20.6	-2.3	-34.6	-0.4	-1.6	-0.6									
10	3	125.519	93	1.900	1.954	0.056	-180	-163.46	-16.32	23.0	2.0	-37.3	-2.6	-0.9	0.0									
10	3	128.519	95	2.000	1.890	0.110	-180	-163.52	-16.48	23.0	-6.0	-40.3	-3.3	-0.6	0.6									
10	3	131.519	97	2.100	2.026	-0.026	-160	-163.32	3.32	23.9	-9.0	-43.6	-4.4	-0.3	0.4									
10	3	134.519	99	2.200	2.226	0.026	-180	-164.44	-15.96	23.0	-12.0	-46.3	-5.3	0.3	0.3									
10	3	137.519	101	2.300	2.364	0.036	-180	-165.44	-15.99	23.0	-14.0	-49.0	-6.0	4.0	1.3									
10	3	140.519	103	2.500	2.502	-0.002	-180	-165.41	-15.99	23.0	-14.0	-49.0	-6.0	4.0	1.3									

\* TRK TAU 1 = (TRK RG - .25) x 3600/TRK RT  
 \*\* TRK TAU 2 = (TRK RG - 1.8) x 3600/TRK RT

76-23-7-2

FIGURE 7-2. A SAMPLE LISTING OF THE CAS/TRACKER MERGE PROGRAM PRINTOUT

The tracker (phototheodolites/EAIR) range separation measurements were checked for gross errors such as those caused when a phototheodolite station completely lost sight of the aircraft. Following this preliminary screening, samples of the range and range rate errors, or the differences between the CAS and tracker ranges and range rates, respectively, were taken from each run. In the case of the head-on runs, where the rates of closure were relatively high, all of the points or epoch values were selected. Sample sizes for these runs generally varied between 6 and 15 values. Random samples of 24 errors were generally taken from the runs corresponding to the other maneuvers, since many epochs of data were usually available. A detailed screening of these error samples was then performed. Estimates of the mean and standard deviation were computed for each sample, and statistical tests were applied. Finally, overall estimates for Mini-CAS and CAU range and range rate errors were obtained. The range and range rate error analyses are described below:

RANGE ERROR ANALYSIS. A visual screening of the range errors within each of the samples was performed and the following was observed: For three or four consecutive epochs, the errors would increase in a positive direction and then drop back down again on the following epoch. The process would then begin all over again. The cause of this systematic bias was found to be in the CAS photopanel instrumentation. By design, the photopanel range measurement reads linearly from 0 to 0.1 nmi higher than it should, as the range increases from a minus 1 nmi to a plus 1.99 nmi, 2 nmi to 4.99 nmi, 5 nmi to 7.99, and so on. A program was developed for a desk-top computer to remove this "sawtooth" bias from the range errors.

Using the corrected range errors, a simple linear regression analysis was performed on each sample to determine if there was any relationship between range error and the range separation of the two aircraft. Since the coefficients of correlation were generally within  $\pm .5$ , no linear relationship was assumed. A representative number of histograms were constructed and these indicated that range error could be assumed to be normally distributed. Finally, each error sample was visually checked to determine if all of the values contained in the sample could be considered from the same normal distribution. Where certain errors were questionable, a statistical test for "outliers" was applied. Only a few such values were actually found, and these were removed from their respective samples.

For each range error sample, estimates of the mean and standard deviation were calculated. An analysis of the Mini-CAS/CAU estimates obtained from flights 1, 2, and 3 indicated that even for the same maneuver type, statistically significant run-to-run and flight-to-flight variations existed. Therefore, these runs were not considered usable for Mini-CAS and CAU range error estimation. Statistical tests were made on the Mini-CAS/Mini-CAS run estimates from flights 4 and 5 and the CAU/CAU run estimates from flights 6 and 7. For both the Mini-CAS/Mini-CAS and CAU/CAU flights, no significant differences were found between the equipment standard deviation estimates for any run. For each run, then, the standard deviations were pooled. In the case of the mean estimates, only a few runs showed to have a significant difference. These runs were removed from the analysis and combined means were calculated for the other runs.

A general determination was then made concerning the quality of the tracker (phototheodolites/EAIR) data throughout each run based on the tracker design specifications. The specified 1-sigma figure for EAIR range error is 0.01 nmi, with a figure of .01 degrees given for azimuth and elevation error. In order to evaluate the position measurement accuracy of the phototheodolites, it is necessary to refer to the maximum error curves shown in figures 2-6 and 2-7 of reference 6. Generally, these curves indicate that position measurement error increases as the target moves away from the baseline presented by the two tracking stations. In addition, as the angle drawn from the target to the two tracking stations gets close to 0° or 180°, the position error increases very rapidly. The actual CAS flightpaths were checked against the EAIR and phototheodolite position measurement accuracy characteristics, and only those runs for which good tracker data were obtained throughout the run, were selected for the analysis. The run mean and standard deviation estimates used in the final Mini-CAS and CAU range accuracy analysis are given in tables 7-2 and 7-3, respectively.

TABLE 7-2. MINI-CAS RANGE ERROR ESTIMATES (nmi)\*

<u>Maneuver Type</u>	<u>Flight No.</u>	<u>Run No.</u>	<u>Sample Size</u>	<u>Mean</u>	<u>Standard Deviation</u>
Head-on	4	2	16	.0254**	.0345
	4	9	22	-.0103	.0322
	4	15	28	.0068	.0349
	4	16	41	-.0086	.0345
	5	2	27	-.0034	.0402
	5	11	27	.0067	.0386
	5	13	28	-.0037	.0387
90° Closure	4	14	28	.0053	.0283
	5	3	48	-.0028	.0344
30° Closure	4	13	48	.0269	.0388
	5	4	48	.0292	.0339
Tail-chase	4	7	33	-.0177	.0349
	5	7	47	.0089**	.0431
	5	14	47	-.0062	.0329

\* The Mini-CAS 1 and Mini-CAS 2 means for each run were combined and their standard deviations pooled.

\*\* Removed from the analysis following statistical tests of homogeneity.

TABLE 7-3. CAU RANGE ERROR ESTIMATES (nmi)\*

<u>Maneuver Type</u>	<u>Flight No.</u>	<u>Run No.</u>	<u>Sample Size</u>	<u>Mean</u>	<u>Standard Deviation</u>
Head-on	6	2	13	-0.0118**	0.0339
	7	9	26	.0295	.0303
	7	11	26	.0199	.0333
90° Closure	7	12	47	.0150	.0314
15° Closure	6	5	46	.0244	.0468
	7	5	48	.0244	.0422
Tail-chase	7	6	39	.0166	.0347

\* The CAU 1 and CAU 2 means for each run were combined and their standard deviations pooled.

\*\* Removed from the analysis following statistical tests of homogeneity.

Statistical tests were performed to determine if the range error means and standard deviations within each of the mini-CAS and CAU maneuver types could be considered representative of the same normal distribution. The results of these tests indicated that for each maneuver type, the standard deviation estimates were not significantly different. Therefore, pooled estimates of the standard deviations were computed for each maneuver type and these are given in table 7-4. Significant differences between the mean estimates were found for the head-on and tail-chase Mini-CAS maneuvers and the CAU head-on maneuver. The tests were repeated for these maneuvers with the suspect values removed, and no significant differences were found. Combined mean estimates were then computed for each maneuver type, and these are also given in table 7-4.

Statistical tests were then performed to determine if the range error estimates varied significantly with the type of maneuver flown. In the case of the Mini-CAS, a significant difference was determined between the mean estimates. The 30° closure estimate was removed and the test was repeated with no significant difference observed. Also, no significant difference was found between the Mini-CAS standard deviation estimates. For the CAU, a significant difference was obtained between the standard deviations. The test was repeated without the 15° closure estimate and no significant difference was found. The mean estimates, less the 15° closure estimate, were tested and no significant difference was shown. Maneuver mean estimates were then combined and overall estimates of -0.0038 nmi and 0.0191 nmi were obtained for Mini-CAS and CAU mean range errors, respectively. Maneuver standard deviations were pooled, and overall estimates of 0.0361 nmi and 0.0323 nmi were obtained for Mini-CAS and CAU range error standard deviations, respectively.

TABLE 7-4. SUMMARY OF THE CAS RANGE ERROR ESTIMATES (nmi)

Maneuver Type	MinicAS		CAU	
	Mean	Standard Deviation	Mean	Standard Deviation
Head-on	-0.0023	0.0364	0.0247	0.0322
90° Closure	.0002	.0323	.0150	.0314
30° Closure	.0281	.0364	---	---
15° Closure	---	---	.0244	.0445
Tail-chase	-.0109	.0375	.0166	.0347
Overall	-.0038*	.0361	.0191**	.0323**

\* Does not include the mean estimate for the 30° closure.

\*\* Does not include the estimate for the 15° closure.

AD-A037 435

NATIONAL AVIATION FACILITIES EXPERIMENTAL CENTER ATL--ETC F/G 1/2  
FLIGHT TEST AND EVALUATION OF MDEC (MCDONNELL DOUGLAS ELECTRONI--ETC(U)  
FEB 77 T J TURNOCK, H SCOZZAFAVA

UNCLASSIFIED

FAA-NA-76-23

FAA-RD-75-231

NL

3 of 3  
ADA037435



END

DATE  
FILMED  
4-77

3 OF 3

ADA037435

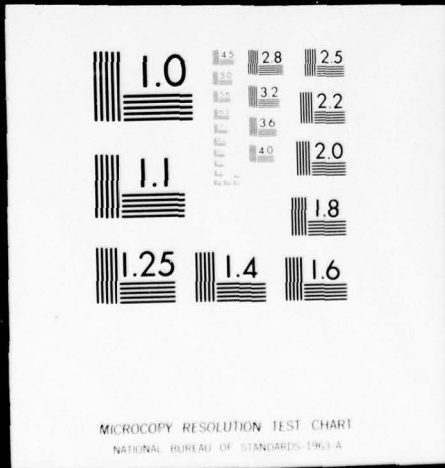

The reasons for the higher Mini-CAS mean range error estimate at the 30° closure and the higher CAU range error standard deviation estimate at the 15° closure mentioned above could not be specifically determined. The design of these equipments does not suggest that a difference should occur at these particular angles of closure. Therefore, it is concluded that they resulted from some anomaly associated with the flight tests and not to the design itself.

As mentioned previously, the closing range rates associated with the various maneuvers flown varied from the 0 to 440 knots. The fact that general agreement existed between the various maneuver mean and standard deviation estimates for both the Mini-CAS and CAU indicates that range error is independent of the closing range rate.

Comparing the overall Mini-CAS and CAU range error estimates given in table 7-4, there is general agreement in the standard deviation estimates. The mean estimates however do show some variation. Since the operational and environmental conditions associated with the flight testing were similar for both equipment types, it is concluded that the approximately 0.02-nmi difference in these mean estimates is due to a difference within the equipments themselves.

RANGE RATE ERROR ANALYSIS. In an attempt to provide homogeneous range rate error samples, only those errors for which the CAS closing range rates were within 20 knots of the nominal range rate, were selected in each sample. For example, if the nominal range rate were 300 knots for a head-on run, then only the range rate errors associated with 280, 300, and 320 knot closing range rates were analyzed. A representative number of histograms were constructed and these indicated that range rate errors could be assumed to be normally distributed. Finally, each error sample was visually examined to determine if all of the values contained in the sample could be considered from the same normal distribution. Where certain errors were questionable, a statistical test for "outliers" was applied. Only a few such values were actually found, and these were removed from their respective samples.

For each range rate error sample, estimates of the mean and standard deviation were calculated. As in the case of the range error analysis discussed previously, only the range rate error estimates from flights 4, 5, 6, and 7 were included in the analysis, since similar equipments were used for a particular flight. Again, the equipment mean and standard deviation estimates for each run were statistically compared, and only those runs for which no significant differences were found were left in the analysis. Finally, only those runs for which the quality of the tracker (phototheodolites/EAIR) data were considered acceptable throughout the run were analyzed. The equipment mean and standard deviation estimates for the runs used in the final Mini-CAS and CAU range rate accuracy analysis are given in tables 7-5 and 7-6, respectively.

As indicated in tables 7-5 and 7-6, the equipment estimates from each run were not lumped together as was done with the range error estimates. The reason for this was that it was observed that the mean range rate error estimates seemed to be directly related to the CAS closing range rate. Therefore, a simple linear regression and correlation analysis was performed using the 32 Mini-CAS means and the 12 CAU means from the tables to quantify the

TABLE 7-5. MINI-CAS RANGE RATE ERROR ESTIMATES (KNOTS)

Maneuver Type	Flight No.	Run No.	Equipment No.	Closing Range Rate (knots)*	Sample Size	Mean	Standard Deviation
Head-on	4	9	1	320	7	11.73	6.32**
			2	323	15	12.46	12.57
	4	15	1	326	15	5.35	16.70
			2	330	24	8.04	18.03
	4	16	1	395	21	16.92	13.86
			2	399	21	19.52	16.41
	5	2	1	283	12	11.61	14.25
			2	277	15	4.34	14.95
	5	9	1	316	11	10.08	20.05
			2	327	11	6.17	18.72
	5	11	1	402	10	19.21	11.86
			2	401	16	11.68	13.05
	5	13	1	331	13	8.38	9.04
			2	333	16	11.24	9.65
90° Closure	4	12	1	198	12	5.39	9.12
			2	203	15	4.85	10.93
	4	14	1	233	14	11.18	9.12
			2	227	15	4.11	14.08
	5	3	1	182	24	5.56	13.10
			2	183	24	8.69	14.77
30° Closure	4	13	1	91	24	4.34	9.57
			2	84	24	1.71	5.84**
	5	4	1	88	23	1.95	10.68
			2	93	24	3.60	13.26
15° Closure	5	5	1	36	18	2.18	7.71
			2	35	22	1.42	9.18
Tail-chase	4	7	1	71	17	.66	15.67
			2	61	16	-5.23	17.41
	5	7	1	63	24	2.81	12.83
			2	68	23	7.73	12.37
	5	14	1	30	24	-2.83	13.87
			2	33	23	3.81	13.17
Overall					542	***	13.5

\* Average of the CAS closing range rates during the run.

\*\* Estimate was not included in the overall estimate below.

\*\*\* See Figure 7-4 for estimation of mean range rate error.

TABLE 7-6. CAU RANGE RATE ERROR ESTIMATES (KNOTS)

Maneuver Type	Flight No.	Run No.	Equipment No.	Closing Range Rate (knots)*	Sample Size	Mean	Standard Deviation
Head-on	6	9	1	321	14	6.64	9.05
			2	329	11	8.59	14.18
	7	9	1	320	14	7.10	8.20
			2	323	12	7.04	15.10
	7	11	1	416	14	14.50	11.81
			2	413	12	12.71	16.66
90° Closure	7	12	1	183	24	2.76	15.94
			2	184	24	1.45	15.39
15° Closure	7	5	1	45	24	2.08	18.15
			2	41	24	-1.58	14.72
Tail-chase	7	6	1	39	21	-.68	15.99
			2	39	17	-3.85	16.02
Overall					211	**	14.9

\* AVERAGE OF THE CAS CLOSING RANGE RATES DURING THE RUN.

\*\* SEE FIGURE 7-4 FOR ESTIMATION OF MEAN RANGE RATE ERROR.

relationship between mean range rate error and CAS closing range rate. The coefficients of correlation were .8 and .9 for the Mini-CAS and CAU, respectively, which are considered highly significant. The estimates of both regression lines along with their plots are shown in figure 7-3. Figure 7-3 indicates that mean range rate errors of 0 to 24 knots can be expected for the Mini-CAS and -3 to 22 knots for the CAU, as the closing range rate increase from 0 knots to 700 knots.

A visual inspection of the range rate error standard deviation estimates given in tables 7-5 and 7-6 indicates that these estimates generally did not seem to vary with maneuver type or CAS closing range rate. A statistical test of homogeneity was performed on the Mini-CAS estimates and a significant difference was determined. The test was repeated with two of the suspect standard deviations removed and no significant difference was found. The standard deviation estimates were then pooled to provide an overall estimate of Mini-CAS range rate error standard deviation of 13.5 knots. In the case of the CAU standard deviation estimates, no significant difference was determined. These standard deviation estimates were then pooled to provide an overall estimate of CAU range rate error standard deviation of 14.9 knots.

The regression line estimates shown in figure 7-3 indicate that both Mini-CAS and CAU range rate can be expected to read higher by a figure equal to approximately 3.5 percent of the CAS closing range rate. The reason for this error is primarily due to the design of these equipments. The time difference between the internal 5-MHz clock pulses is 200 ns, which corresponds to 194 feet. However, the dR/dT logic for both equipments rounds off this time difference to an equivalent of 200 feet, resulting in a 3-percent high range rate measurement. This design relationship is also shown on figure 7-3.

The range rate error regression line estimates in figure 7-3 and the overall standard deviation estimates given in tables 7-5 and 7-6 indicate that there is very little difference in Mini-CAS and CAU range rate accuracy.

#### WARNING-TIME ACCURACY.

The Tau 2 and Tau 1 warning time accuracies were determined from the collision encounters flown. The warning-time data were derived using phototheodolite and EAIR position data at the instant of time a first alarm occurred in a Tau zone. The majority of the encounters failed to provide usable Tau 2 and Tau 1 warning-time data, due to instrumentation or equipment problems experienced during the early flights, late phototheodolite tracking in the Tau 2 zone, and bad tracker data. In other words, the epoch times of the majority of first alarms were late or ambiguous because of testing problems, and not due to CAS failures that occurred during flight.

As a result, only 17 Tau 2 and 39 Tau 1 warning-time events were obtained for accuracy analysis. These sample sizes were further reduced by the necessity to subdivide the Tau 2 and Tau 1 groups into equipment (Mini-CAS and CAU) categories. It was established, however, that the resulting small groups of warning-time data gave valid estimates of warning time accuracy. The data were representative of larger groups and the estimates compared well with those expected from known equipment characteristics.

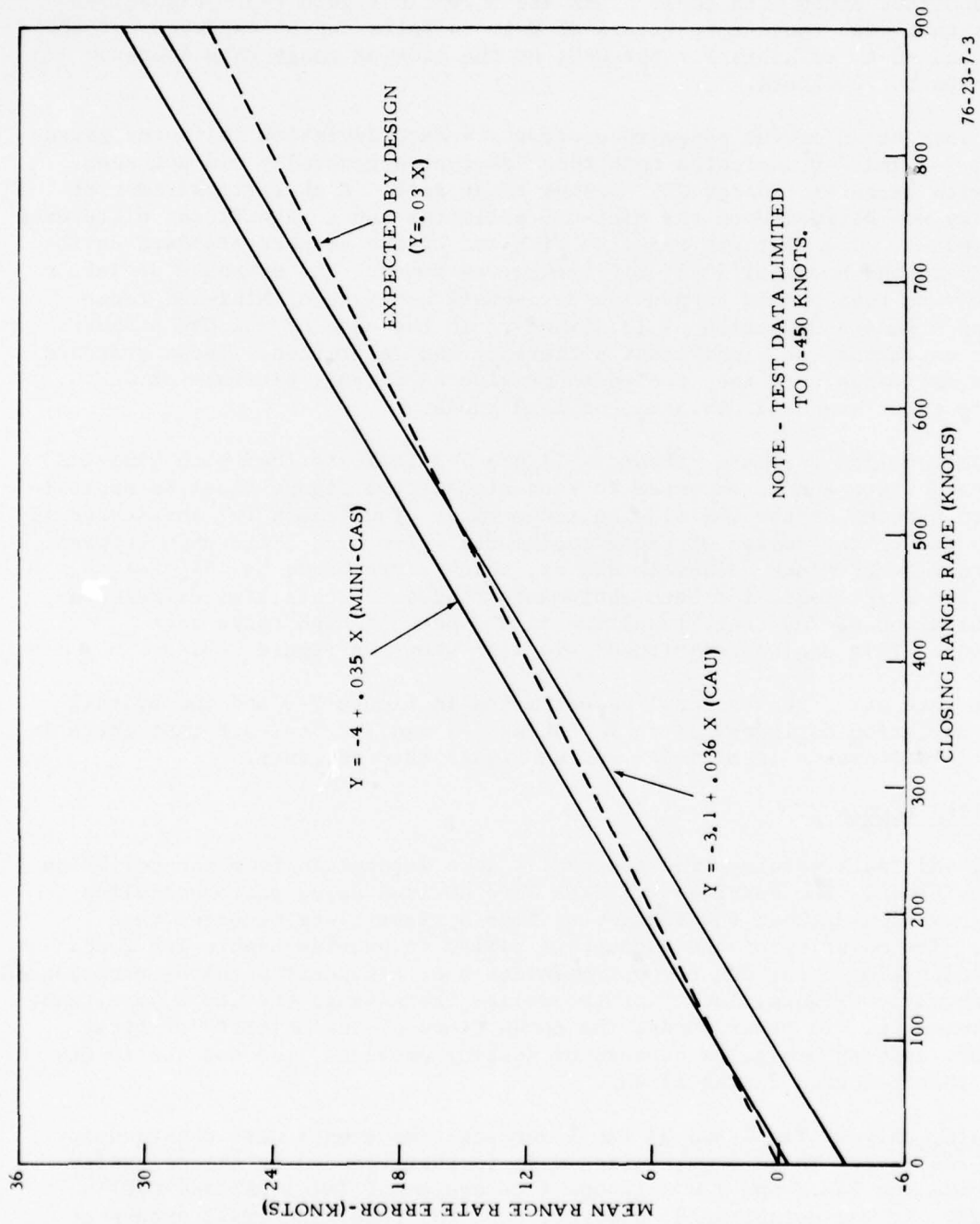

76-23-7-3

FIGURE 7-3. MEAN RANGE RATE ERROR ESTIMATION

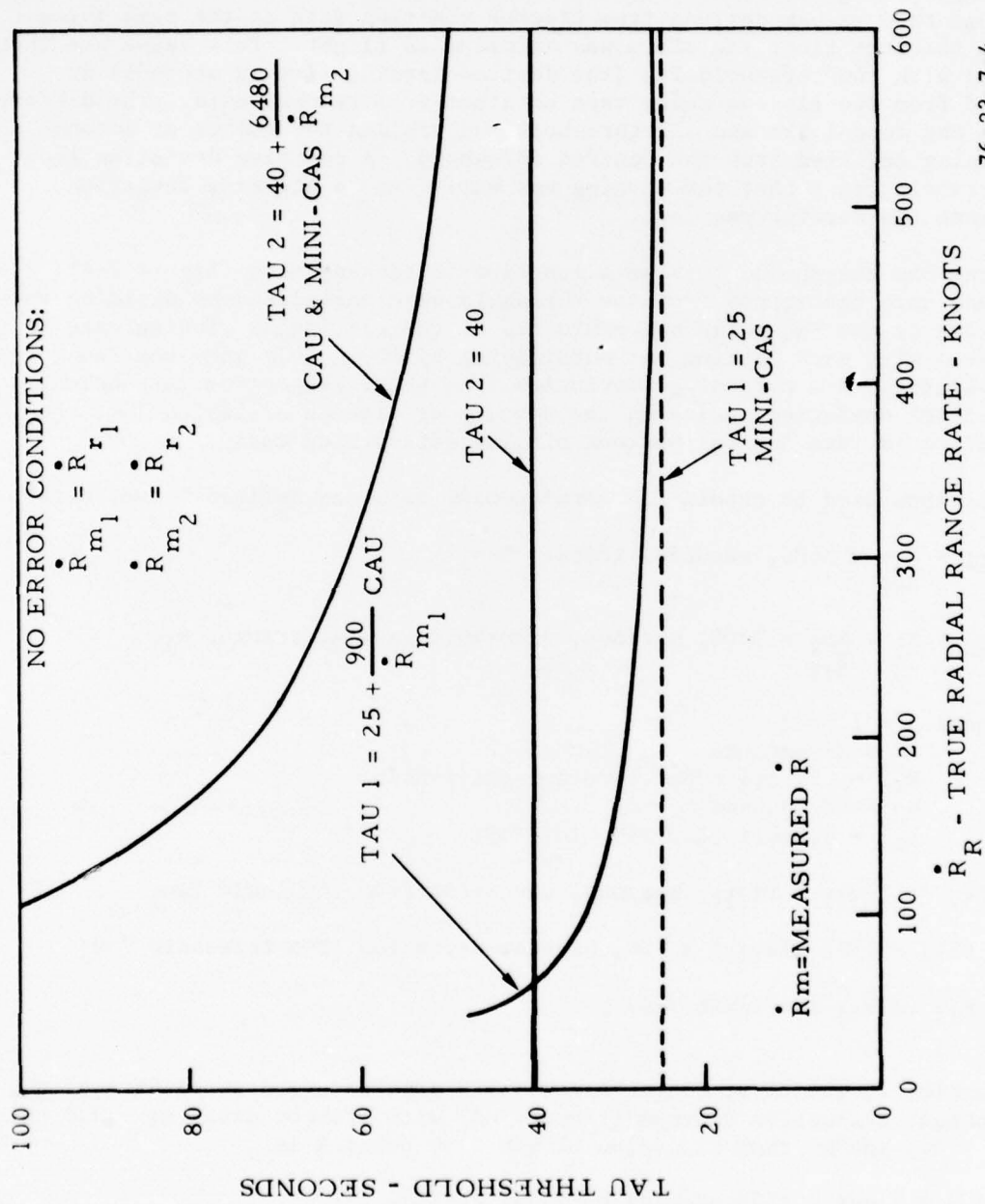

76-23-7-4

FIGURE 7-4. TAU 1 AND TAU 2 THRESHOLD AS FUNCTION OF TRUE RADIAL RANGE RATE

### WARNING-TIME EQUATIONS.

The Tau 2 and Tau 1 warning time data were determined using phototheodolite/EAIR tracker position data as the reference standard. An actual value of Tau (range ÷ range rate, in seconds) was established by referring to the range and range rate values derived from tracker position data at the same instant of time that the first Tau alarm was recorded in flight. This value was then compared with the threshold Tau (the desired warning time in seconds) as computed from the closing range rate obtained from tracker data. The difference between the actual Tau and the threshold Tau yielded the number of seconds the Tau warning deviated from the desired threshold. A positive deviation from the threshold meant that the warning was early, and a negative deviation meant that the warning was late.

Since the Tau thresholds vary as a function of closing rate (figure 7-4), the early and late deviations from the threshold were normalized by dividing those deviations by the Tau threshold evaluated at the particular closing rate associated with each warning and multiplying by 100. This gave the Tau 2 and Tau 1 warnings as a percentage deviation from their respective thresholds. A percentage deviation indicates the percent of time to collision lost when a first alarm is late and the percent of time gained when early.

The equations used to obtain Tau warning-time data, as defined above, were

$$\text{Tau}_{jT} = \frac{R_{jT}}{\dot{R}_{jT}} \times 3600, \text{ seconds, tracker Tau}_j$$

$$\text{Tau}_{jt} = K_j + \frac{R_{0j}}{\dot{R}_{jT}} \times 3600, \text{ seconds, threshold Tau}_j \text{ at tracker } \dot{R}_{jT}$$

Where  $j = 1$  or  $2$

$$K_1 = 25 \text{ seconds}$$

$$R_{01} = .25 \text{ nmi (CAU), } 0.0 \text{ nmi (Mini-CAS)}$$

$$K_2 = 40 \text{ seconds}$$

$$R_{02} = 1.8 \text{ nmi (CAU and Mini-CAS)}$$

$$\text{DEV}_j = (\text{Tau}_{jT} - \text{Tau}_{jt}) \text{ seconds, deviation from threshold Tau}_j$$

$$\% \text{ DEV}_j = (\text{DEV}_j / \text{Tau}_{jt}) \times 100, \text{ percent deviation from threshold Tau}_j$$

Note:  $\dot{R}_{jT}$  is  $\dot{R}_{mj}$  of figure 7-4.

For example, if the first alarm in the Tau 2 zone occurred at point A of the range threat evaluation diagram (figure 7-5) with tracker data,  $R_T = 5.0$  nmi and  $R_T = 340$  knots, then the value of Tau 2 at point A is

$$\text{Tau}_{2T} = \frac{5.0 \text{ nmi}}{340 \text{ knots}} \times 3600 \frac{\text{seconds}}{\text{hour}} = 52.941 \text{ seconds}$$

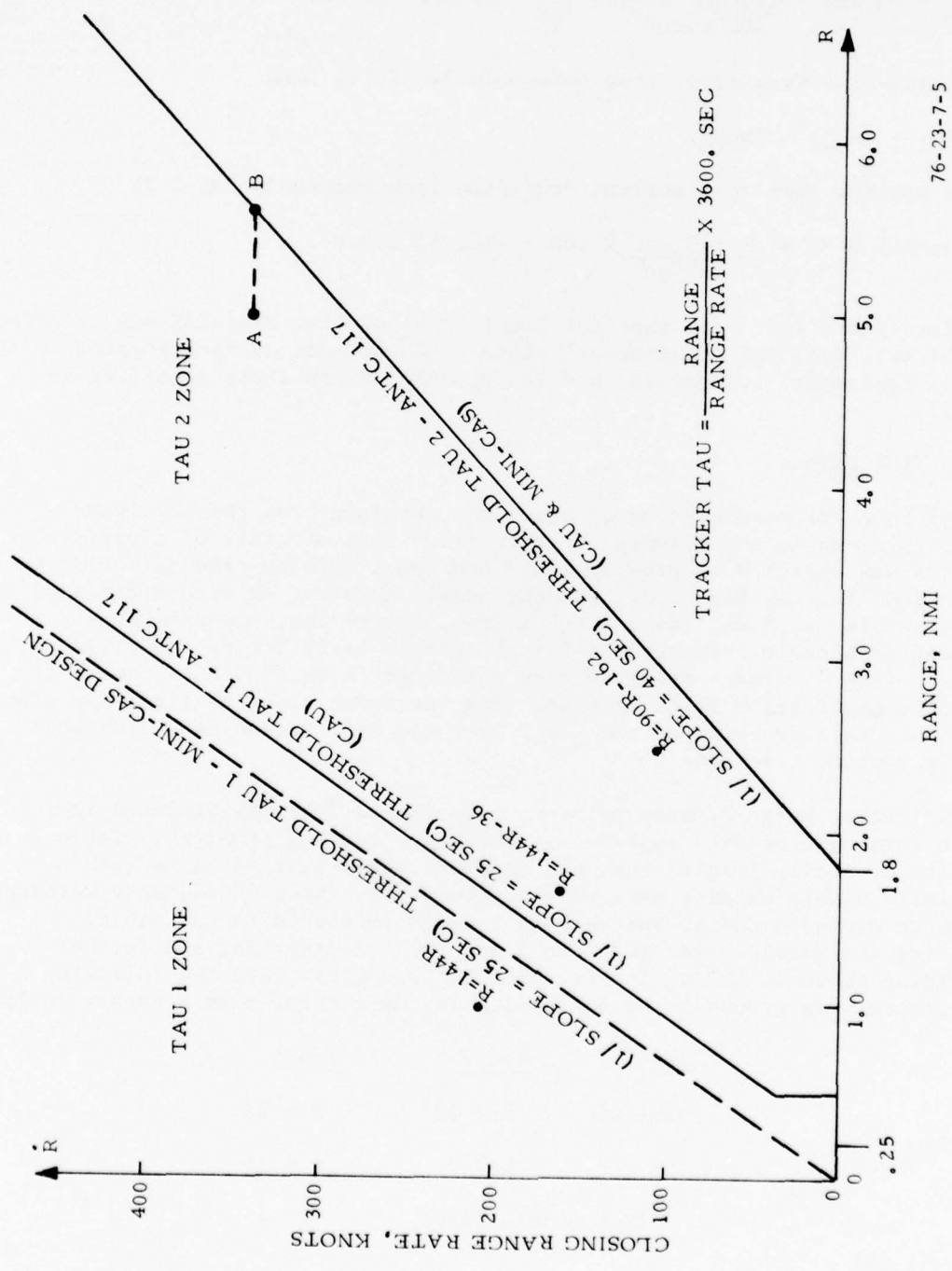

76-23-7-5

FIGURE 7-5. RANGE AND RANGE RATE THREAT EVALUATION

and the value of threshold Tau 2 at point B is

$$\text{TAU}_{2t} = 40 \text{ sec} + \frac{1.8 \text{ nmi}}{340 \text{ knots}} \times 3600 \frac{\text{sec}}{\text{hr}} = 59.059 \text{ seconds}$$

The warning-time deviation, from threshold Tau 2, is then

$$\text{DEV}_2 = \text{Tau}_{2T} - \text{Tau}_{2t}$$

And the warning time as a percent deviation from threshold Tau 2 is

$$\text{Percent DEV}_2 = \frac{-6.118 \text{ sec}}{59.059 \text{ sec}} \times 100 = -10.36\% \text{ (late).}$$

Regarding figure 7-5, note that the Tau 1 threshold for Mini-CAS has an offset ( $R_{01}$ ) of zero nmi, and a reciprocal slope of 25 seconds as incorporated in the Mini-CAS equipment. Otherwise, the Tau thresholds are those specified in ANTC 117.

#### WARNING-TIME DATA.

The data base for warning-time accuracy was obtained from the collision encounters flown in the flights of table 7-1. Each aircraft of a particular encounter was expected to provide Tau 2 and Tau 1 warning-time data from the first alarms in each Tau zone. In many cases, however, an aircraft failed to provide usable Tau 2 and Tau 1 first alarms, due to instrumentation or equipment problems experienced in flight, particularly during the early flights 1 thru 7. These problems were reflected in the CAS data itself as apparent communication failures which made the epoch times of first Tau alarms uncertain. Late tracking in the Tau 2 zone and bad tracker data also gave unusable warning time data.

The CAS/Tracker Merge-Program printout (see figure 7-2) was screened to exclude warning-time data degraded by the above testing problems. Table 7-7 shows (by aircraft, flight, run, and CAS equipment) that 52 cases with potentially usable warning data were obtained. In these cases, many warning times were excluded due to the various reasons indicated in the table. Separating the usable cases into Tau 2 and Tau 1 categories, and further subdividing these by CAS equipment (Mini-CAS and CAU), gave the following small sample size groups to be dealt with in the warning-time accuracy analysis:

<u>CAS</u>	<u>Tau 2</u>	<u>Tau 1</u>
Mini-CAS	N = 10	N = 23
CAU	N = 7	N = 16

(N = sample size)

TABLE 7-7. DATA BASE OF POTENTIALLY USABLE WARNING TIMES

Aircraft No. 1 (N-377)						Aircraft No. 2 (N-376)					
Flight No.	Run No.	2/3 A/C	EQ CD	Tau 2	Tau 1	Flight No.	Run No.	2/3 A/C	EQ CD	Tau 2	Tau 1
3	1	2	M2	NL	X	3	1	2	C2	CM	X
	2			NL	X		X			X	
	3			NL	X		LT			X	
4	2	2	M2	LC	X	4	4	2	M1	X	NL
	9			LT	X		9			LC	X
	13			X	RM		13			CM	BT
	14			LT	X		14			LT	X
	15			X	X		15			X	X
	16			X	X		16			X	X
5	3	2	M2	NL	X	5	3	2	M1	X	X
	9			NL	X		4			X	X
	11			NL	X		9			LC	X
	13			NL	AS		11			X	CM
6	4	2	C1	X	X	6	9	2	C2	LC	X
	9			LC	X		7			CM	X
7	2	2	C1	LT	BT	7	3	2	C2	CM	X
	3			BT	X		4			BT	X
	9			X	X		7			CM	X
	11			LT	X		12			X	X
17	10	2	M2	X	AS	17	10	2	C2	LT	X
	34			LT	X		34			4	3
34	4	3	C1	X	NL	34	6			X	NL
	12			AS	X		12			BT	X
	14			AS	X		14			X	NL
	40			2	3		M1			LT	AS
X Usable warning time						59	9	3	M1	NL	X
M1 - Mini-CAS 1						60	5	3	M1	NL	X
M2 - Mini-CAS 2							7			NL	X

C1 - CAU 1  
C2 - CAU 2

NL - No warning lights (M2-bad C3 connector, wrong presets; M1-IC chip A3 bd.)  
 LT - Late tracker data (Tau 2 zone)  
 CM - Ambiguous warning time due to apparent communication failure  
 LC - Late tracker data (Tau 2) and apparent communication failure  
 BT - Bad tracker data  
 AS - Altitude separation precludes warning lights  
 RM - R min warning light, not included

A computer program (CAS Model 1) was developed to calculate warning-time deviations and percent deviations for both Tau 2 and Tau 1 data. The calculated values are shown in table 7-8 for Tau 1 and table 7-9 for Tau 2. The percent deviation columns of each table are ordered from earliest to latest values. Early deviations due to high (+) R CAS errors and late deviations due to low (-) R CAS errors are noted. Tracker R values are shown for each deviation. In addition, mean and standard deviation statistics ( $\bar{X}$ , S) for both deviations and percent deviations are presented.

Computer warning-time plots (figure 7-6 and figure 7-7) were made for the Mini-CAS and CAU Tau data. It should be noted that the scales of each figure are tracker range and range rate. The solid slant lines are Tau thresholds, and the dashed lines are boundary lines for warning-time deviations 6 seconds late relative to their threshold lines. Except for the Mini-CAS Tau 1 threshold line, all threshold lines are those specified by ANTC 117. The threshold line for Mini-CAS Tau 1 has an offset ( $R_{01}$ ) of zero nmi and a reciprocal slope of 25 seconds as incorporated in the Mini-CAS equipment (see also figure 7-5). Each symbol was plotted at the tracker range and range rate corresponding to the instant of time when the first alarm occurred. Most of the symbols plotted lie within the regions bounded by the 6 seconds (late) and threshold lines.

Assuming a normal distribution with parameters ( $\bar{X}$ , S) for each group of warning-time deviations gave the following comparison between theoretical and observed probabilities of deviations not being later than 6 seconds:

	<u>Tau 1</u>	<u>Tau 2</u>
Mini-CAS	P = .99 Pobsv = $\frac{22}{23} = .96$	P = .92 Pobsv = $\frac{9}{10} = .90$
CAU	P = .79 Pobsv = $\frac{12}{16} = .75$	P = .94 Pobsv = $\frac{6}{7} = .86$

Where  $P = \text{Prob}(\text{DEV}_j \geq -6 \text{ seconds}) = 1 - \phi(Z)$

$$Z = (-6 - (\bar{X})) / s$$

and  $\phi(Z)$  = value of cumulative standard normal distribution at Z.

#### WARNING-TIME ANALYSIS.

To confirm the validity of treating the normalized warning-time data as being normally distributed, each group of percent deviation data on tables 7-8 and 7-9 was subjected to an analysis of variance test for normality. This test, designated as a W-test (reference 13) is an effective procedure for evaluating the assumption of normality against a wide spectrum of non-normal alternatives, even if only a relatively small number of observations are given. Its application to the data permitted each group (Mini-CAS Tau 1, CAU Tau 1, Mini-CAS Tau 2,

TABLE 7-8. TAU ONE WARNING TIME DATA AND STATISTICS

CAU Tau 1				Mini-CAS Tau 1			
<u>Dev.</u> <u>Sec.</u>	<u>Dev.</u> <u>%</u>	<u>Note</u> <u>No.</u>	<u>R TRK</u> <u>Knots</u>	<u>Dev.</u> <u>Sec.</u>	<u>Dev.</u> <u>%</u>	<u>Note</u> <u>No.</u>	<u>R TRK</u> <u>Knots</u>
-1.382	-3.53	1(+35)	63	1.830	7.32	1(+36)	324
-1.421	-4.73	1(+20)	178	.717	2.87	1(+13)	227
-2.498	-8.96	1(+6)	314	-.148	-0.59	2	208
-2.905	-9.59	1(+13)	170	-.201	-0.80	2	348
-2.951	-9.75	1(+13)	171	-.599	-2.39	2	385
-2.882	-10.58	2	403	-.606	-2.42	2	83
-4.520	-13.80	2	116	-1.060	-4.24	2	273
-4.178	-14.24	2	207	-1.139	-4.55	2	322
-6.026	-17.39	2	93	-1.347	-5.39	2	226
-4.950	-17.83	2	326	-1.524	-6.10	2	172
-5.229	-18.79	2	319	-1.525	-6.10	2	310
-5.227	-18.84	2	327	-1.532	-6.13	2	387
-5.972	-21.89	2	394	-1.687	-6.75	2	277
-6.084	-22.06	2	350	-2.002	-8.01	2	315
-6.844	-24.61	3(-40)	320	-2.105	-8.42	2	172
-8.039	-26.93	3(-5)	185	-2.301	-9.20	2	280
			246	-2.401	-9.61	2	311
			AVG.	-2.521	-10.08	2	240
				-3.467	-13.87	3(-17)	304
				-3.573	-14.29	2	403
				-3.605	-14.42	2	326
				-3.653	-14.61	3(-32)	303
				-6.120	-24.48	3(-20)	394
							286
							AVG.

<u>Dev.</u>	<u>% Dev.</u>	<u>Dev.</u>	<u>% Dev.</u>
X = -4.444 seconds	X = -15.218%	X = -1.764 seconds	X = -7.056%
S = 1.951 seconds	S = 6.956%	S = 1.673 seconds	S = 6.695%
N = 16	N = 16	N = 23	N = 23

- NOTES: 1. First alarm one epoch early due to high R CAS error, (+xx) knots.  
 2. Epoch number of first alarm unaffected by high or low R CAS errors.  
 3. First alarm one epoch late due to low R CAS error, (-xx) knots.

TABLE 7-9. TAU TWO WARNING TIME DATA AND STATISTICS

CAU Tau 2				Mini-CAS Tau 2			
Dev. Sec.	Dev. %	Note No.	$\dot{R}$ TRK Knots	Dev. Sec.	Dev. %	Note No.	$\dot{R}$ TRK Knots
0.688	1.13	1(+6)	314	1.529	2.52	1(+28)	312
.672	.97	1(+20)	220	1.404	2.45	1(+46)	374
.317	.42	1(+16)	184	.189	.22	2	136
.028	.05	2	336	-.157	-.21	2	186
-2.884	-3.92	2	193	-.378	-.65	2	360
-2.915	-3.88	2	184	-1.265	-1.72	2	194
-6.758	-6.41	4		-1.313	-2.14	2	305
		(-20,-20)		-3.282	-5.76	2	382
			218	-4.428	-6.26	2	210
			AVG.	-8.613	-7.49	3(-3)	86
							254 AVG.

Dev.	% Dev.	Dev.	% Dev.
$\bar{X}$ = -1.550 seconds	$\bar{X}$ = -1.660%	$\bar{X}$ = -1.631 seconds	$\bar{X}$ = -1.903%
S = 2.790 seconds	S = 3.016%	S = 3.087 seconds	S = 3.537%
N = 7	N = 7	N = 10	N = 10

- NOTES: 1. First alarm one epoch early due to high  $\dot{R}$  CAS error, (+xx) knots.  
 2. Epoch number of first alarm unaffected by high or low  $\dot{R}$  CAS errors.  
 3. First alarm one epoch late due to low  $\dot{R}$  CAS error, (-xx) knots.  
 4. First alarm two epochs late due to low  $\dot{R}$  CAS error, twice in succession, (-xx, -xx) knots.

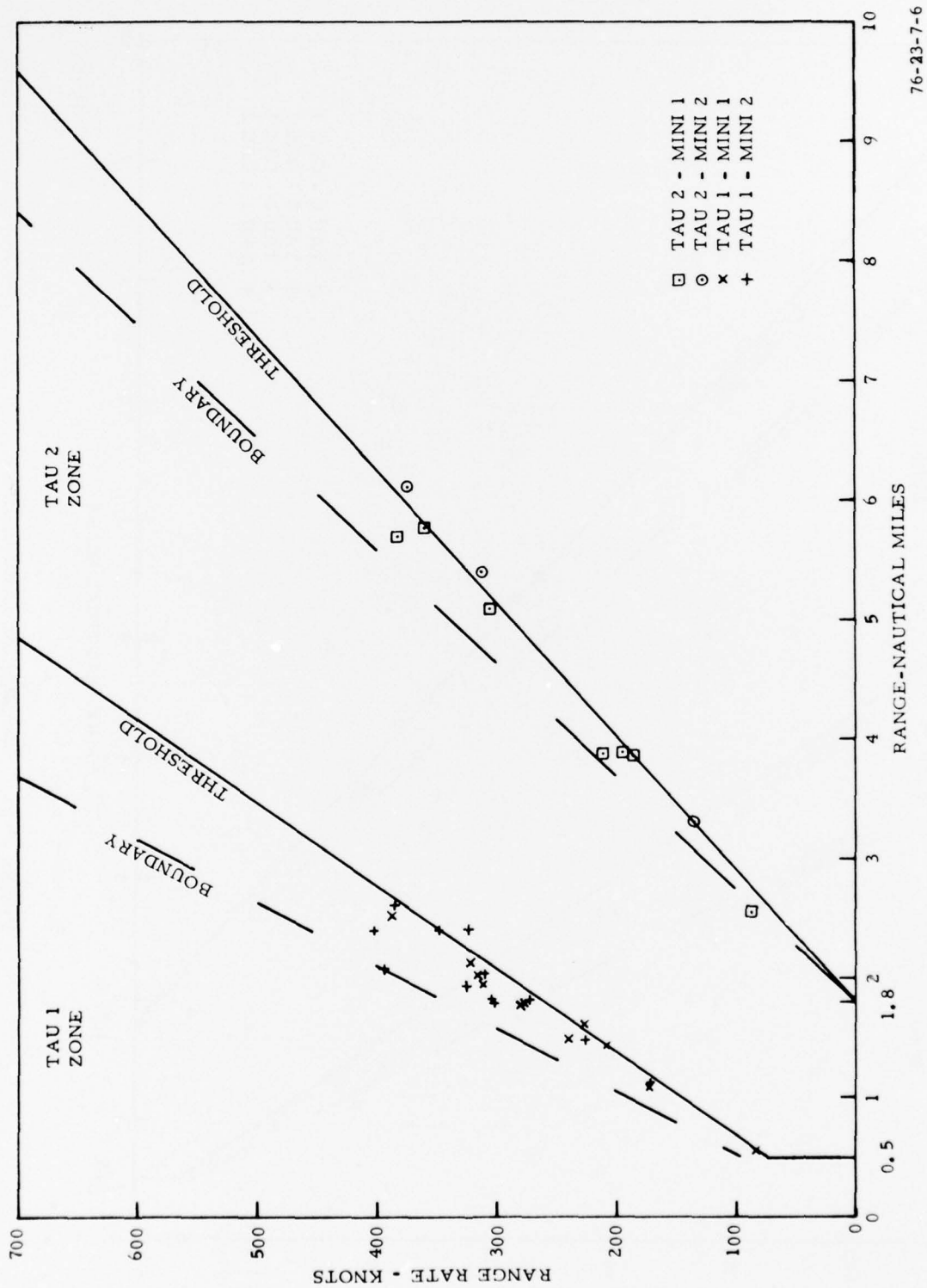

76-23-7-6

FIGURE 7-6. MINI-CAS WARNING-TIME PLOT

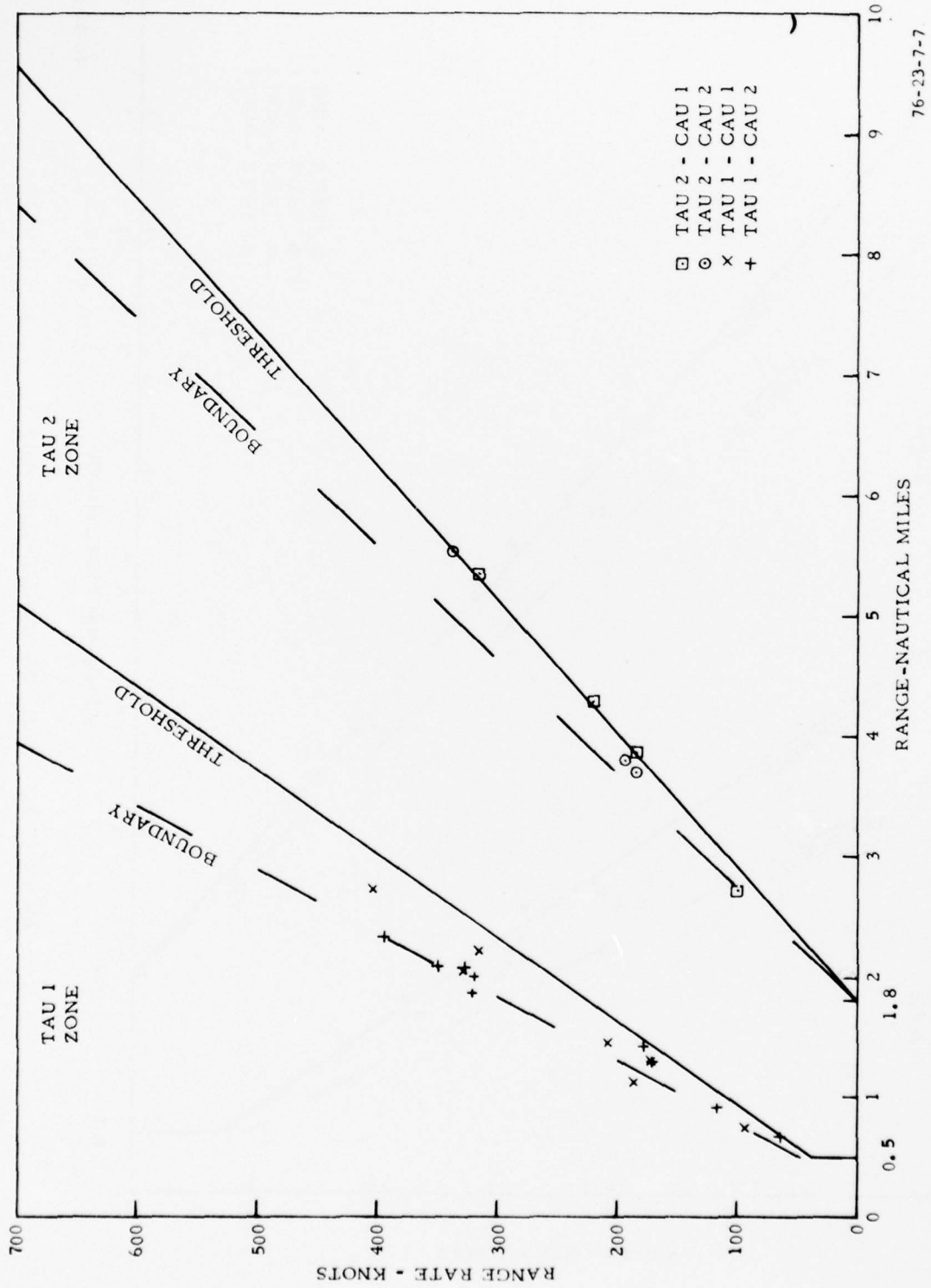

76-23-7-7

FIGURE 7-7. CAU WARNING-TIME PLOT

CAU Tau 2) of percent deviation data to be treated as normally distributed. With this established, a histogram of frequency of occurrence versus percent deviation from threshold Tau was made for each group of data. In each case, the number of intervals and size of each interval were determined to reflect the expected normality. Figures 7-8 and 7-9 show the histograms and the fitted normal distributions.

In addition, it was established that each group of warning-time deviation data (non-normalized) may also be treated as normally distributed. Histograms and the fitted normal distributions for these data are shown in figure 7-10.

To confirm the validity of the statistics ( $\bar{X}$ , S) obtained for warning-time deviations (see figure 7-10), a comparison was made with the corresponding expected values based upon known equipment characteristics.

In the case of the observed means ( $\bar{X}$ ), there was the following agreement:

<u>Data Group</u>	<u>Observed <math>\bar{X}</math></u>	<u>Expected <math>\bar{X}</math></u>
CAU Tau 1	-4.44 seconds	-4.5 seconds, due to epoch phasing (3 seconds $\div$ 2) and 2 threats/3 tries (3 seconds)
Mini-CAS Tau 1	-1.76 seconds	
CAU Tau 2	-1.55 seconds	-1.5 seconds, due to epoch phasing (3 seconds/2)
Mini-CAS Tau 2	-1.63 seconds	

where epoch phasing refers to the alignment of two successive (R, R') points (3 seconds apart) with respect to the Tau threshold line. On the average, the first of these (R, R') points will be 1.5 seconds early, and the second point (when alarm first occurs) will be 1.5 seconds late.. Since two threats out of three are required for the first CAU Tau 1 alarm, where all first alarms in the CAU Tau 1 data were due to the first two successive threats, an additional 3 seconds (one epoch) is expected in this group.

In the case of the observed standard deviations(S), which are measures of dispersion or spread of the data about their respective  $\bar{X}$  values, there are two aspects to be considered. First, the small sample size groups should be representative of the types of early and late deviations expected in large sample size groups. In large sample size groups, the early tail of each group's distribution is due to high (+) values of R CAS errors causing early alarms, and the late tail is due to low (-) values of R CAS errors and, on a much lesser scale, to missed communications. Between these extremes lie the majority of deviations, the alarm time of which is unaffected by either high or low R CAS errors. Tables 7-8 and 7-9 show the expected presence of deviation values in the tails of each group due to high and low R CAS errors. And, except for the smallest sample size (N=7) CAU Tau 2 group, the majority of the deviations are unaffected by either high or low R CAS errors.

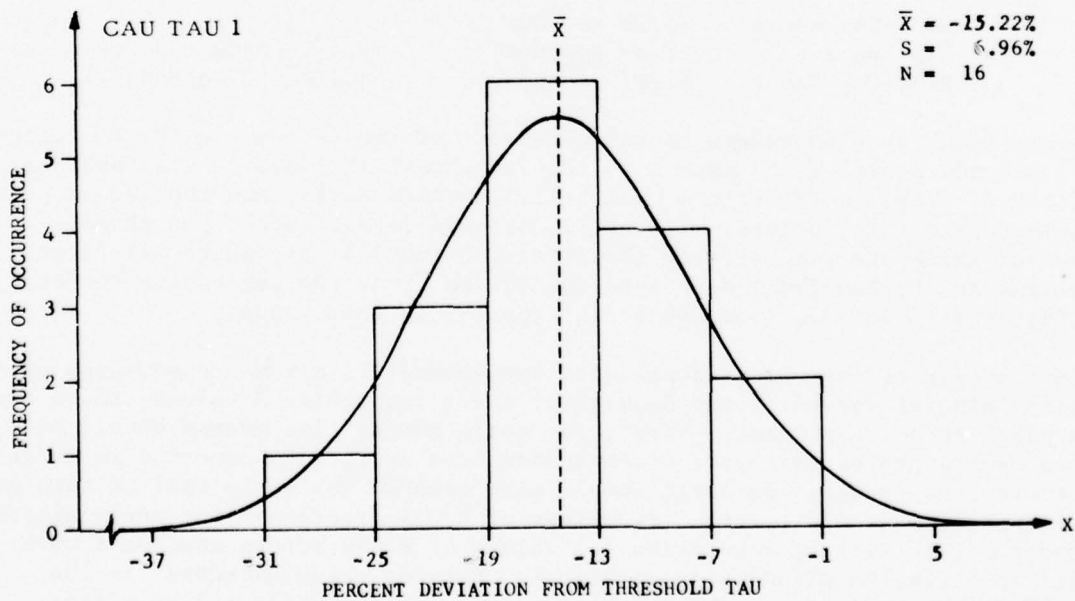
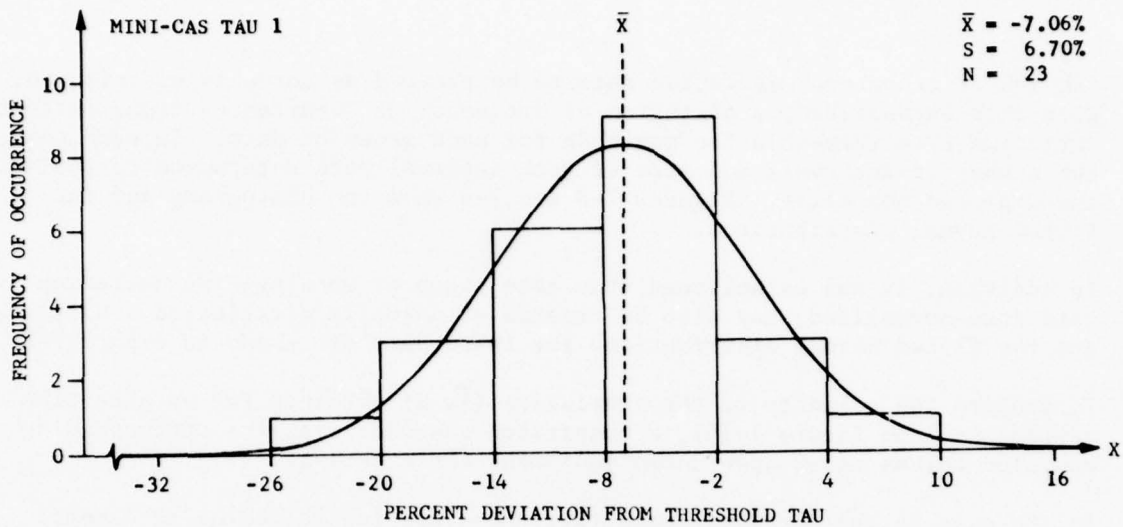

76-23-7-8

FIGURE 7-8. HISTOGRAMS AND FITTED NORMAL DISTRIBUTIONS FOR WARNING-TIME PERCENT DEVIATION DATA (TAU 1)

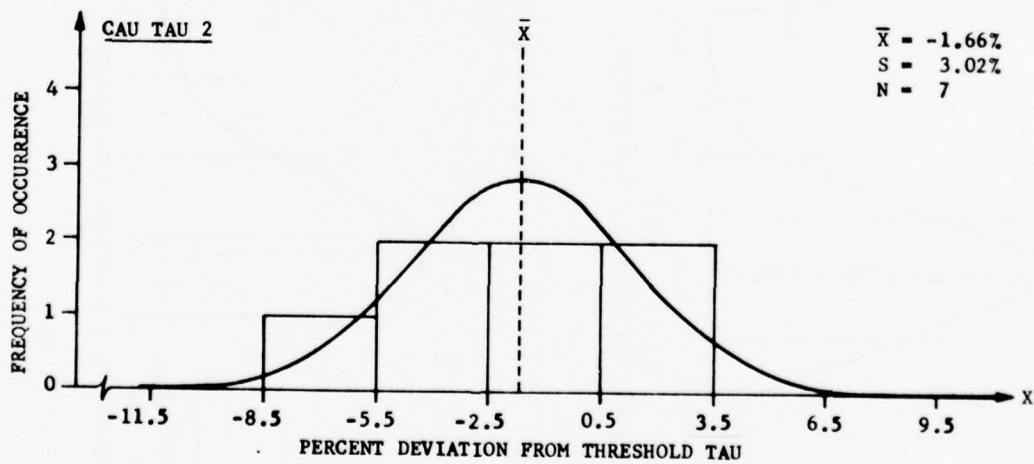
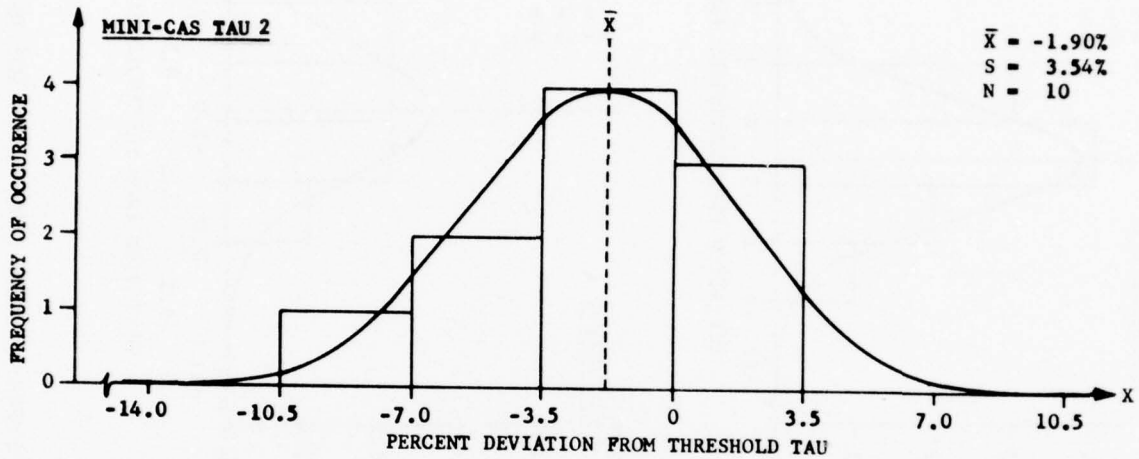

76-23-7-9

FIGURE 7-9. HISTOGRAMS AND FITTED NORMAL DISTRIBUTIONS FOR WARNING-TIME PERCENT DEVIATIONS DATA (TAU 2)

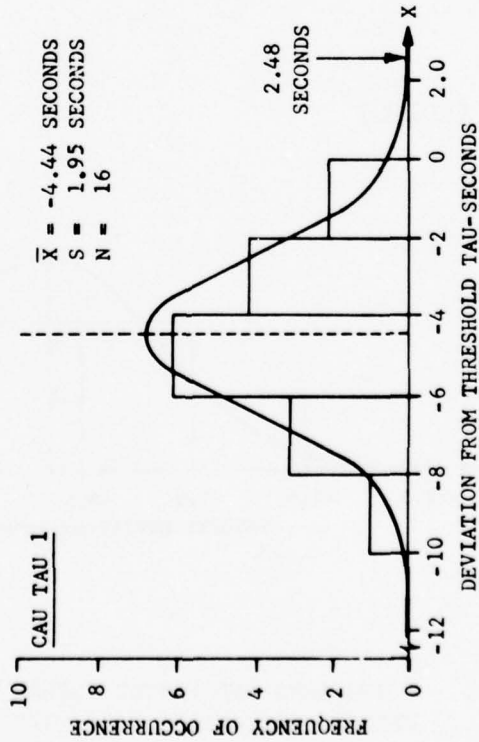
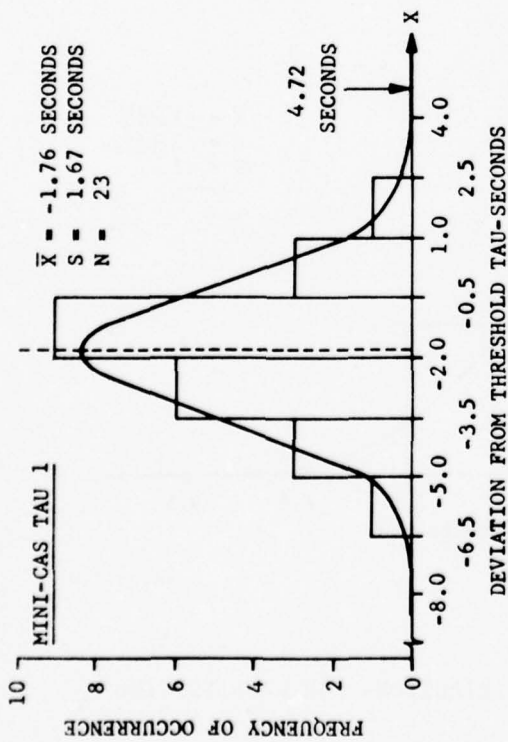
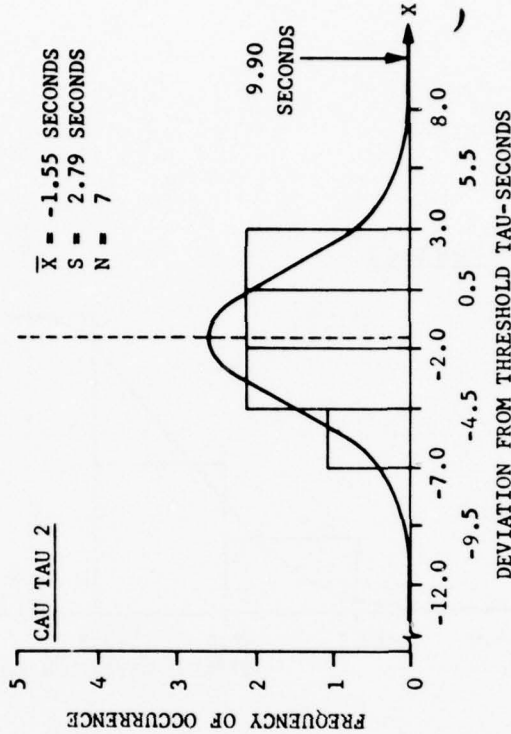
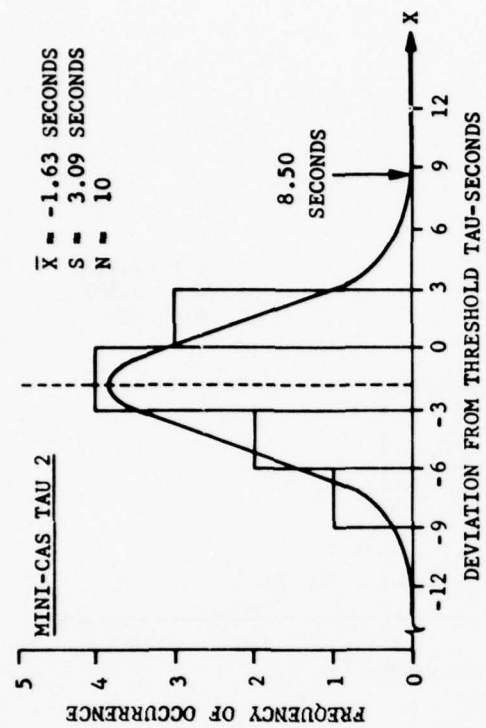

76-23-7-10

FIGURE 7-10. HISTOGRAMS AND FITTED NORMAL DISTRIBUTIONS FOR WARNING-TIME DEVIATION DATA (TAU 2 AND TAU 1)

Second, the magnitude of each standard deviation should be such that the spread of the fitted normal distribution compares favorably with an estimate of the mean warning-time deviation at the earliest possible threat. A high  $\dot{R}$  CAS error of +54 knots, occasionally observed among all high range rate error data, was used to estimate this mean. In the Mini-CAS Tau 1 group, for example, the expected or mean deviation at the earliest possible threat was estimated as:

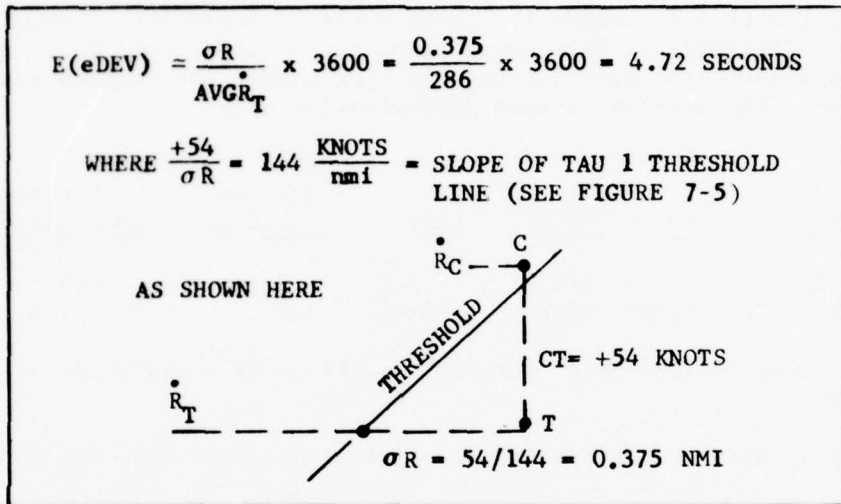

Note that  $\dot{R}$  CAS is 54 knots greater than  $\dot{R}$  TRK, such that a first alarm occurs  $\sigma_R$  nmi before the threshold line. The earliest deviation and its mean value over the observed  $\dot{R}_T$  values are,

$$eDEV = \frac{\sigma_R}{\dot{R}_T} \times 3600, \text{ seconds}$$

$$E(eDEV) = \frac{\sigma_R}{AVG \dot{R}_T} \times 3600, \text{ seconds}$$

Estimates of the mean value for each data group were:

Data Group	Avg $\dot{R}_T$ (Knots)	$\sigma_R$ (nmi)	E(eDEV) (Sec)
Mini-CAS Tau 1	286	0.375	4.72
CAU Tau 1	246	.375	5.48 *
Mini-CAS Tau 2	254	.600	8.50
CAU Tau 2	218	.600	9.90

\* 2.48 seconds (adjusted to second threat)

In the case of CAU Tau 1, the expected value was 5.48 seconds. But, since all deviation data in this group were determined at the second of two successive threats (2 threats out of 3 tries required to alarm), the earliest deviation at the second threat would have an expected value of 5.48 minus 3.00 equals 2.48 seconds. With this adjustment made, a favorable comparison was obtained

for all four data groups. In each case, the fitted normal distribution (figure 7-10) covered the interval  $\bar{X}$  to  $\Sigma(eDEV)$  well. If this were not the case in a particular data group, its standard deviation (S) would be considered too small.

Having established the validity of the statistics (X, and S) for deviation data, the corresponding percentage deviations were considered adequate for both Tau 2 and Tau 1 warning times. Adequate Tau 1 warning-time accuracy is most important; for without it, there would be insufficient warning time to avoid a collision. In this connection, a one-sided lower tolerance limit for percentage deviation data was used to approximate the minimum time left to collision. The results of this approximation were:

Data Group	K*	KS(%)	L(%)	AVG Tau <sub>t</sub> (Seconds)	DEV(L) (Seconds)	Time Left (Seconds)
CAU Tau 1	5.374	37.6	-52.8	29.8	-15.7	14.1
Mini-CAS Tau 1	4.806	32.2	-39.3	25	- 9.8	15.2

\* For minimum proportion of percent deviations (P = .999) and confidence (Y = .99).

where k = tolerance factor for one-sided tolerance limit (Y = .99, P = .999).

S = standard deviation (7.0% for CAU Tau 1, and 6.7 percent for mini-CAS Tau 1).

L = one-sided lower tolerance limit ( $L = \bar{X} - KS$ , where  $\bar{X} = -15.2$  percent for CAU Tau 1 and  $-7.1$  percent for Mini-CAS Tau 1)

AVG Tau<sub>t</sub> = mean value of threshold Tau 1 in a data group.

DEV(L) = warning-time deviation corresponding to L (DEV(L) = L x AVG Tau<sub>t</sub>)

Time Left = warning time left to avoid a collision (Time Left = AVG Tau<sub>t</sub> + DEV(L))

These results imply (with 99-percent confidence) that at least 99.9 percent of CAU Tau 1 warnings are not later than -52.8 percent, and at least 99.9 percent of Mini-CAS Tau 1 warnings are not later than -39.3 percent. A 52.8-percent late warning for CAU Tau 1 corresponds to avoid a collision. A 39.3-percent late warning for Mini-CAS Tau 1 corresponds to a loss of 9.8 out of 25 seconds, leaving 15.2 seconds to avoid a collision.

## CHAPTER 8

### DISPLAY RELIABILITY

#### INTRODUCTION.

Having established adequate communication range and RF communications (reference chapter 6), it is necessary to evaluate the ability of the CAS system to display correct threat information to the pilot.

For purposes of display reliability, all threats were treated as either Tau 2 advisories or Tau 1 commands, depending primarily on the range-divided-by-range-rate criteria. A scheme for classifying displays in each Tau group was based on the definition,

$$\text{Display Reliability} = \frac{\text{Total No. Displays} - \text{No. Lost Displays}}{\text{Total No. Displays}}$$

where Lost Display (Tau 2) = No lights in Tau 2 zone when there should have been,

Lost Display (Tau 1) = No command light in Tau 1 zone when there should have been,

which measures the ability of the CAS system to provide an uninterrupted sequence of expected display advisories and commands to the pilot from the start of the threat at the Tau 2 zone to the end of the threat. Accordingly, the definition allows for separate display reliabilities; one for Tau 2 advisories and one for Tau 1 commands.

#### WARNING-LIGHT PLOTS.

Warning-light performance plots were generated by a computer program (CAS Model 2) as a graphical aid for deriving display reliability data. Excluding encounters of parallel flights, the plot for each encounter is similar to that shown in figure 8-1. A plot is a record of the advisory/command status of warning lights, epoch-by-epoch, from the first hard advisory light after the start of threat logic to the 0.25-nmi cutoff at the end of the threat.

Display reliability data are readily obtained from this type of plot. The total number of displays in figure 8-1, starting from the first hard advisory (the first of two successive advisories where at least one is in the Tau 2 zone), is 17. Two of the 17 have lost lights; one with no lights in the Tau 2 zone when there should have been, and one with no command light in the Tau 1 zone when there should have been. Note that advisories in the Tau 1 zone preceding the first command are counted as Tau 2 displays; they are not lost commands. When evasive maneuvers are employed, advisories in the Tau 1 zone following the last command are counted as Tau 2 displays also. Thus, there are 5 good Tau 1 displays, and 10 good Tau 2 displays.

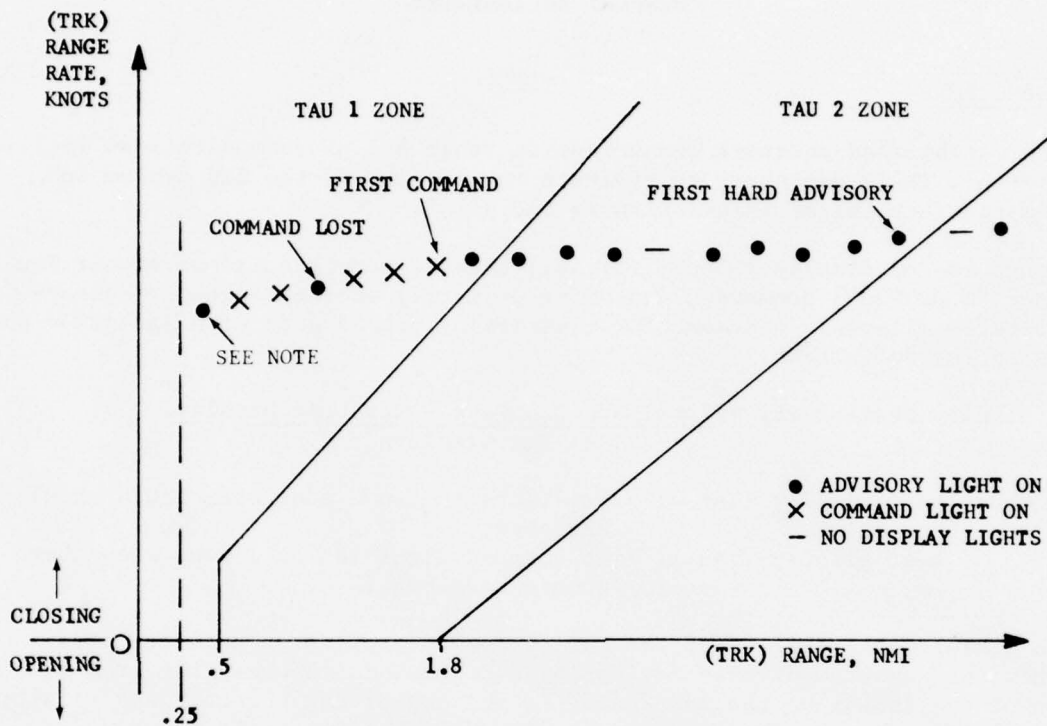

TOTAL DISPLAYS	17,	FROM 1st HARD ADVISORY LIGHT
GOOD DISPLAYS	15	
TAU 1 GOOD	5	
TAU 1 LOST	1	{ NO COMMAND LIGHT IN TAU 1 ZONE WHEN THERE SHOULD HAVE BEEN
TAU 2 GOOD	10*	
TAU 2 LOST	1	{ NO LIGHTS IN TAU 2 ZONE WHEN THERE SHOULD HAVE BEEN

\* WHEN EVASIVE MANUEVERS ARE EMPLOYED, ADVISORIES IN TAU 1 ZONE ARE COUNTED AS TAU 2 DISPLAYS

NOTE: PILOTS INTENTIONALLY INCREASED RANGE TO TURN ON ADVISORY LIGHT.

76-23-8-1

FIGURE 8-1. EXAMPLE WARNING-LIGHT PERFORMANCE PILOT AND RELATED DISPLAY RELIABILITY DATA

The above scheme for classifying displays in each Tau group as either lost or good was based on the definition of display reliability. Since the overall reliability results were good, the distinctions employed to make this classification had no significant effect except to simplify the classification process.

Selected plots of actual warning-light performance are shown in figure 8-2 to 8-7, with display reliability data entered on each figure. These plots were made from the data of single-daisy flights (reference chapter 6). Each single-daisy flight is designed to give two encounters at each angle between radials flown from 180° to -150° in steps of 30°. For example, figure 8-2 and 8-3 are the two encounters of flight 41 at -150° between radials flown. Furthermore, each aircraft in flight 41 has CAU equipment. Thus, the display reliability data for the CAU-CAU configuration at -150° angle between radials are obtained by combining the display data on figure 8-2 with that on figure 8-3.

	<u>Figure 8-2</u>	<u>Figure 8-3</u>	<u>Combined (-150°)</u>
Total Displays	19	19	38
Good Displays	19	19	38
Tau 1 Good	7	8	15
Tau 1 Lost	0	0	0
Tau 2 Good	12	11	23
Tau 2 Lost	0	0	0

The display reliability data of tables 8-1, 8-2, and 8-3 were obtained this way. In fact, the combined display data at -150° above appear in table 8-1.

#### DISPLAY RELIABILITY DATA.

The data base for display reliability was obtained from six selected single-daisy flights in which each CAU-CAU, (Mini-CAS)-(Mini-CAS), CAU-(Mini-CAS) equipment configuration was represented by two flights.

<u>CAS Equipment</u>	<u>Flights</u>
Cau vs. Cau	8, 41
Mini-CAS vs. Mini-CAS	49, 50
CAU vs. Mini-CAS	15, 16

Display reliability data for these equipment groups are shown in table 8-1 to 8-3 by flight number and angles between radials within each flight. The number of lost displays appears in the "Tau 2 lost" and "Tau 1 lost" columns of each table, and notation is provided to indicate the causes of lost displays.

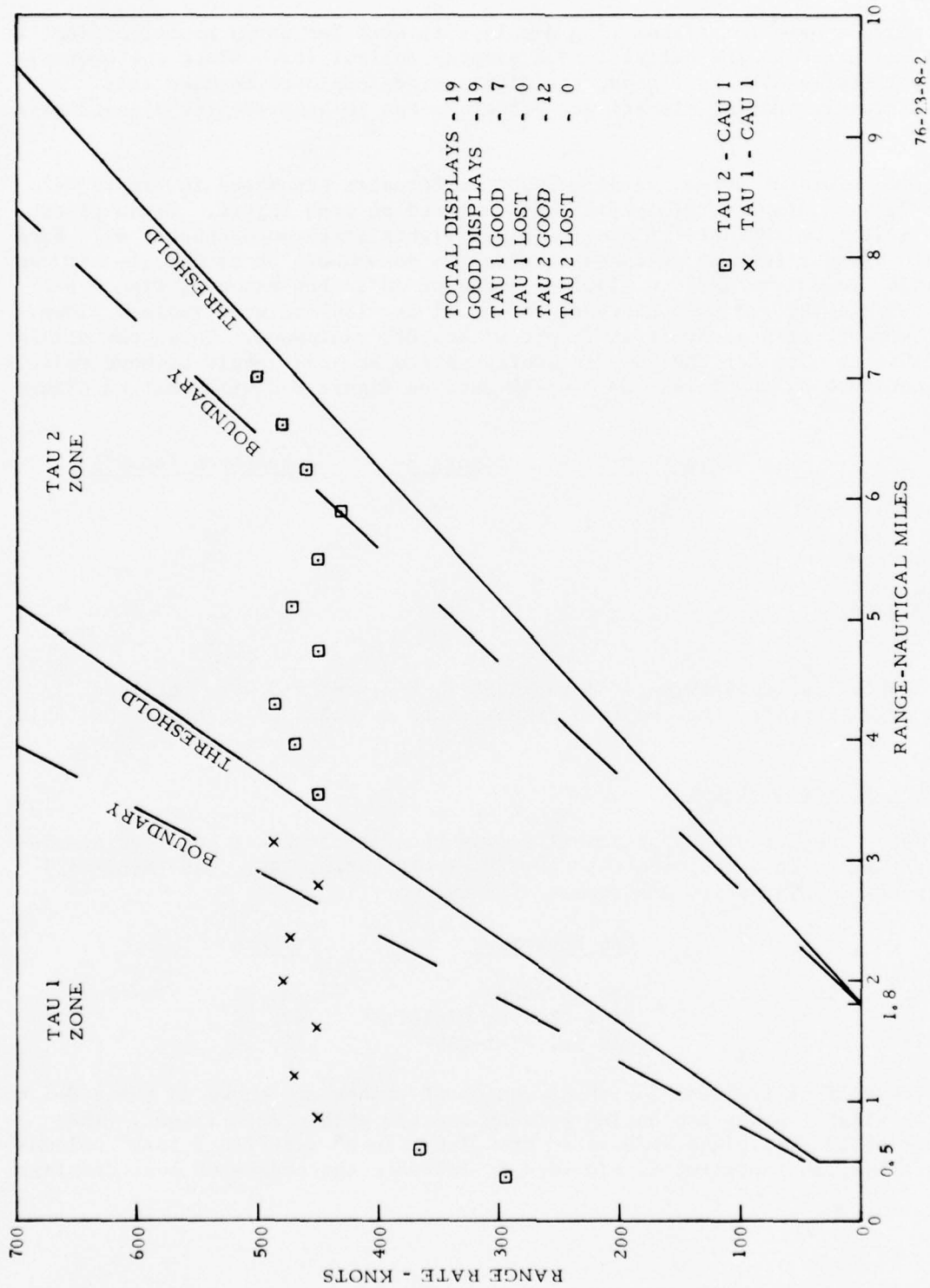

FIGURE 8-2. FLIGHT 41, 90°/300°, -150° ENCOUNTER



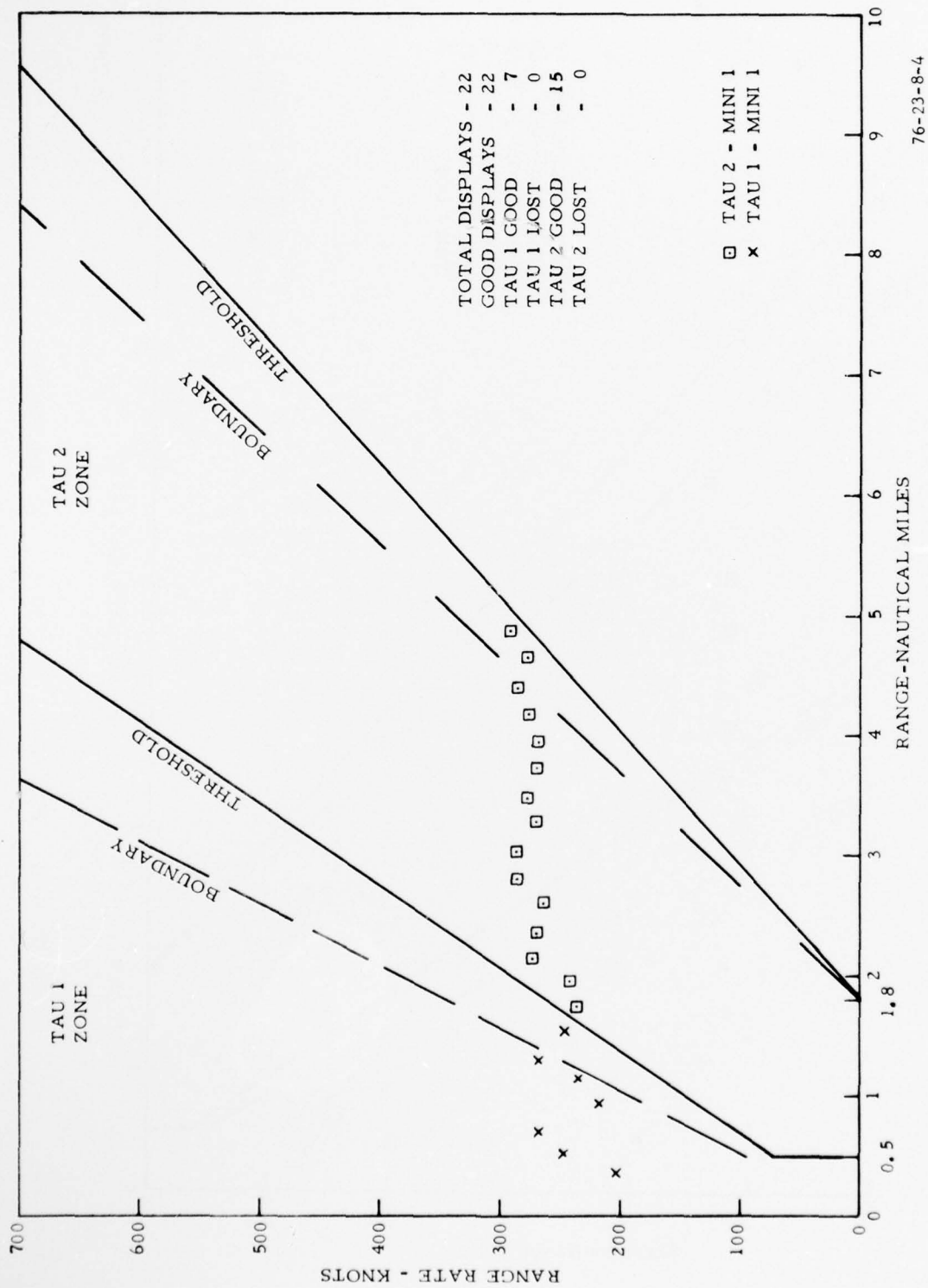

FIGURE 8-4. FLIGHT 49, RUN 7, 90° ENCOUNTER

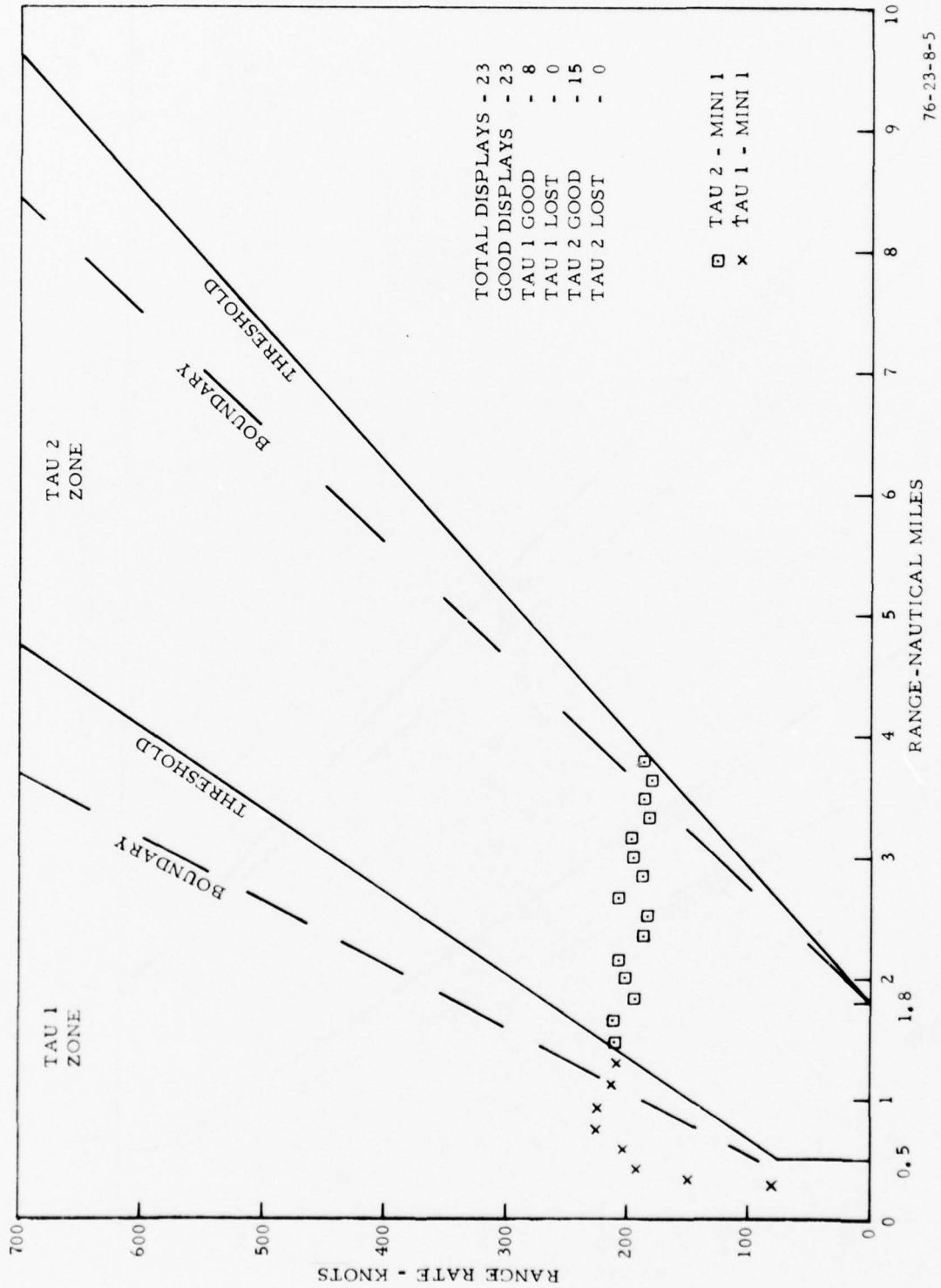

FIGURE 8-5. FLIGHT 49, RUN 8, 90° ENCOUNTER



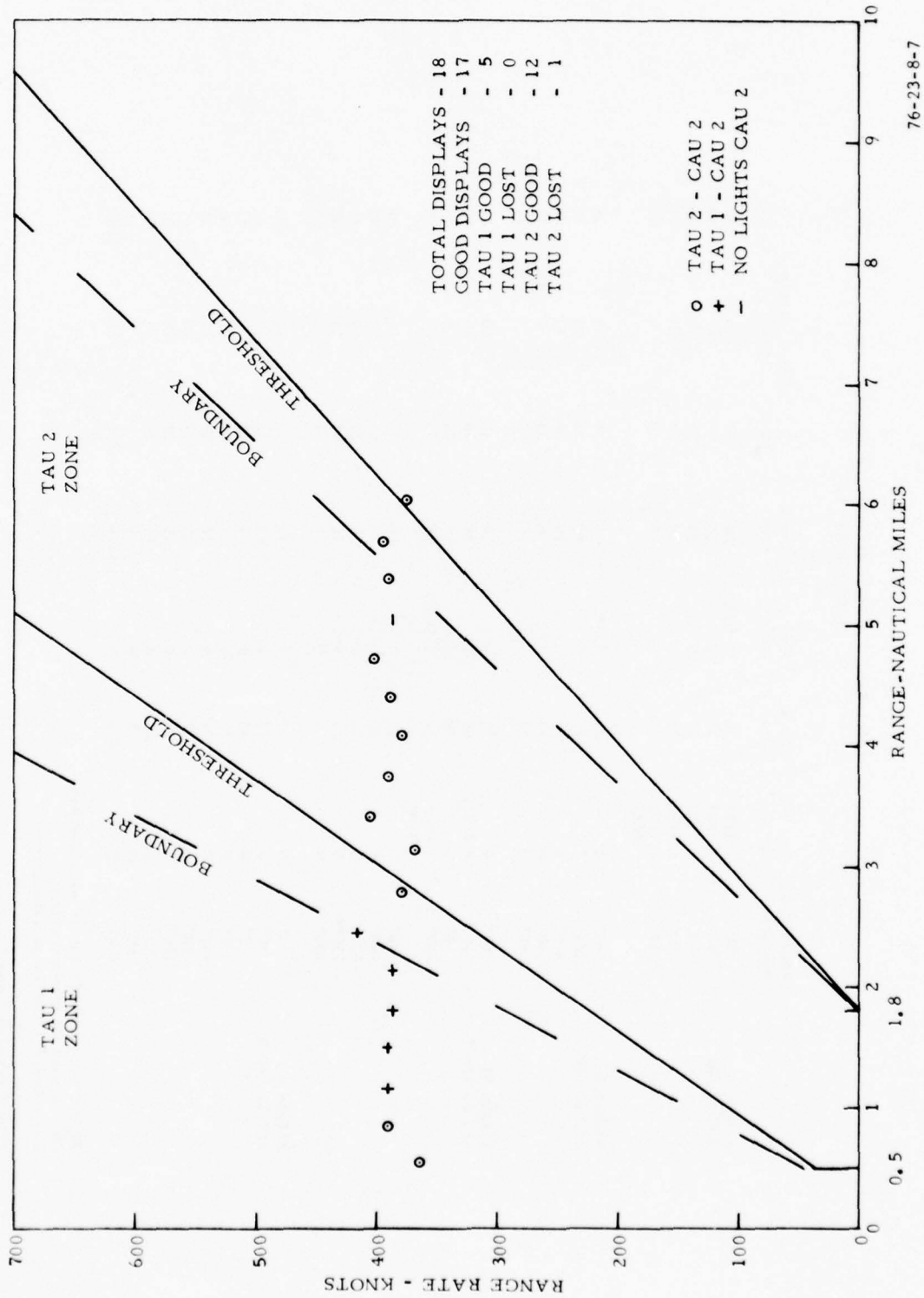

FIGURE 8-7. FLIGHT 15, RUN 2, 75°/255°, 180° ENCOUNTER

TABLE 8-1. DISPLAY RELIABILITY DATA (CAU-CAU),  
FLIGHTS 8 AND 41

Flight	Angle Bet Radials	Tau 2		Tau 1		Total Displays		
		Lost	Good	Lost	Good	Tau 1	Tau 1, 2	
Flight 8 A/C 1, CAU 1	180°	1 (FS)	21	1 (CM)	14	22	15	37
	150°	1 (FS)	24	0	11	25	11	36
	120°	2 (FS)	20	0	14	22	14	36
	90°	1 (FS)	26	0	14	27	14	41
	60°	2 (FS) (CM)	38	0	6	40	6	46
Flight 8 A/C 2, CAU 2	180°	0	34	0	5	34	5	39
	180°	0	26	0	10	26	10	36
	120°	0	26	0	10	26	10	36
	90°	0	33	0	6	33	6	39
	60°	0	43	0	7	43	7	50
Flight 41 A/C 1, CAU 1	60°	0	16	0	10	16	10	26
	30°	1 (LRT)	69	0	16	70	16	86
	0°	0	36	0	8	36	8	44
	-30°	2 (FS) (CM)	51	1 (LRT)	16	53	17	70
	-60°	0	34	0	16	34	16	50
	-90°	0	28	0	14	28	14	42
	-120°	0	21	0	19	21	19	40
	-150°*	0	23	0	15	23	15	38
180°	0	9	0	9	9	9	18	
Flight 41 A/C 2, CAU 2	60°	0	31	0	12	31	12	43
	30°	0	72	0	12	72	12	84
	0°	0	40	0	7	40	7	47
	-30°	0	55	0	11	55	11	66
	-60°	0	37	0	14	37	14	51
-90°	0	31	0	10	31	10	41	
-120°	0	22	0	15	22	15	37	
-150°	0	23	0	14	23	14	37	
180°	0	9	0	9	9	9	18	
Total		10	898	2	324	908	326	1234

FS - Other aircraft future slot checking

CM - Missed RF communication

LRT - Low (-) CAS range rate error

\*See figures 8-2 and 8-3

TABLE 8-2. DISPLAY RELIABILITY DATA (MINI-CAS-MINI-CAS),  
FLIGHTS 49 AND 50

Flight	Angle BET Radials	Tau 2		Tau 1		Tau 1 Good	Tau 2	Total Displays	
		Lost	Good	Lost	Good			Tau 1	Tau 1, 2
Flight 49 A/C 1, Mini-CAS 1	180°	0	14	0	14	14	14	14	28
	150°	0	22	0	14	22	14	14	36
	120°	0	11	0	8	11	8	8	19
	90°*	0	30	0	15	30	15	15	45
	60°	0	39	0	15	39	15	15	54
	30°	0	55	1 (LRT)	16	55	17	17	82
	180°HS	0	8	0	8	8	8	8	16
Flight 49 A/C 2, Mini-CAS 2	180°	0	20	0	15	20	15	15	35
	150°	0	22	0	15	22	15	15	37
	120°	0	11	0	8	11	8	8	19
	90°	0	28	0	17	28	17	17	45
	60°	0	38	0	12	38	12	12	50
	30°	1 (LRT)	55	0	15	56	15	15	71
	180°HS	0	10	0	7	10	7	7	17
Flight 50 A/C 1, Mini-CAS 1	0°	0	51	0	10	51	10	10	61
	-30°	0	30	0	10	30	10	10	40
	-60°	0	43	0	10	43	10	10	53
	-90°	0	12	0	7	12	7	7	19
	-120°	0	21	0	18	21	18	18	39
	-150°	0	18	0	1	18	1	1	19
	Total	1	538	1	235	539	236	236	775

LRT - Low (-) CAS range rate error  
HS - Highspeed, 180° encounter

\*See figures 8-4 and 8-5

TABLE 8-3. DISPLAY RELIABILITY DATA (CAU-MINI-CAS),  
FLIGHTS 15 AND 16

Angle BET Radials	Tau 2		Tau 1		Total Displays	
	Lost	Good	Lost	Good	Tau 1	Tau 1, 2
Flight 15						
180°	0	23	0	13	13	36
A/C 1, Mini-CAS 2	0	29	0	10	10	39
150°						
120°	0	17	0	4	4	21
Flight 15						
180°*	2 (CS)	23	0	13	13	38
A/C 2, CAU 2	0	28	0	11	11	39
150°						
120°	1 (CS)	15	0	6	6	22
Flight 16						
120°	0	16	0	5	5	21
A/C 1, Mini-CAS 2	0	37	0	6	6	43
90°						
60°	1 (LRT)	43	0	8	8	52
30°	0	72	0	7	7	79
0°	0	58	-	-	-	58
-30°	0	38	-	-	-	38
Flight 16						
120°	1 (CS)	15	0	6	6	22
A/C 2, CAU 2	1 (CS)	33	0	9	9	43
90°						
60°	3 (CS)	36	0	11	11	50
30°	2 (CS)	29	0	3	3	34
0°	7 (LRT) (6CS)	56	0	10	10	73
-30°	0	23	0	8	8	31
Total	18	591	0	130	130	739

CS - Other aircraft coslot checking  
LRT - Low (-) range rate error

\* See figures 8-6 and 8-7

### DISPLAY RELIABILITY ANALYSIS.

The causes and number of lost Tau 2 and Tau 1 displays are summarized by

<u>Cause</u>	<u>Tau 2</u>	<u>Tau 1</u>
(CS) Other A/C (Mini-CAS) coslot checking	16	0*
(FS) Other A/C (CAU) future slot checking	7	0*
(LRT) Low (neg.) CAS range rate error	4	2
(CM) Missed RF communication	2	1

\* CAS designed to preclude slot checking in Tau 1 zone.

which shows that most lost Tau 2 displays are caused by slot checking and lost Tau 1 displays are caused by either a low (neg.) CAS range rate error or a missed RF communication.

When the Mini-CAS coslot checks, it drops its altitude transmission, causing the received altitude in the other aircraft to be blank. Since both received range and altitude are required to evaluate a threat, the other aircraft loses its Tau 2 display (one lost Tau 2 threat turns the display lights OFF).

When the CAU future slot checks, it inhibits its transmission of data messages in its own slot (active one) and retransmits these data in a future slot. The other aircraft, not being tuned into this future slot, receives blanks for range and altitude, again causing a lost Tau 2 display.

By CAS design, slot checking occurs on the average once every 15 epochs. For example, flight 16 for the CAU 2 in table 8-3 shows that 13 coslot checks were made by the Mini-CAS during 206 Tau 2 displays--an average of once every 15.8 epochs.

A few lost Tau 2 displays were caused by a low (negative) CAS range rate error. In this case, the actual threat is mistakenly evaluated to be in the zone before Tau 2. Fewer Tau 1 displays were lost due to same cause, because the retention logic of Tau 1 displays requires two successive misses before the Tau 1 lights go OFF. And, the least number of lost displays were caused by RF communication failures.

Estimates of display reliability were obtained from the data in tables 8-1 to 8-3. The results, shown in figures 8-8 to 8-10, were grouped by CAU-CAU, Mini-CAS-Mini-CAS, and CAU-Mini-CAS equipment configurations. Each configuration was further divided into Tau 2, Tau 1, Tau 1 and 2 categories with a bar graph for each radial angle in a Tau category. The ratio of good displays to total displays is shown in each bar graph. The smallest Tau 2 and Tau 1 display reliabilities were 94.2 (at 0°) and 96.4 (at -30°), respectively. By equipment configuration, the smallest display reliability for Tau 2 was 97.0 (CAU-Mini-CAS), and for Tau 1 was 99.0 (CAU-CAU). Thus, display reliability for the CAS equipment was well above 90.0. In fact, all display reliabilities were greater than 95.0 except for the CAU-Mini-CAS at the zero-degree radial angle.

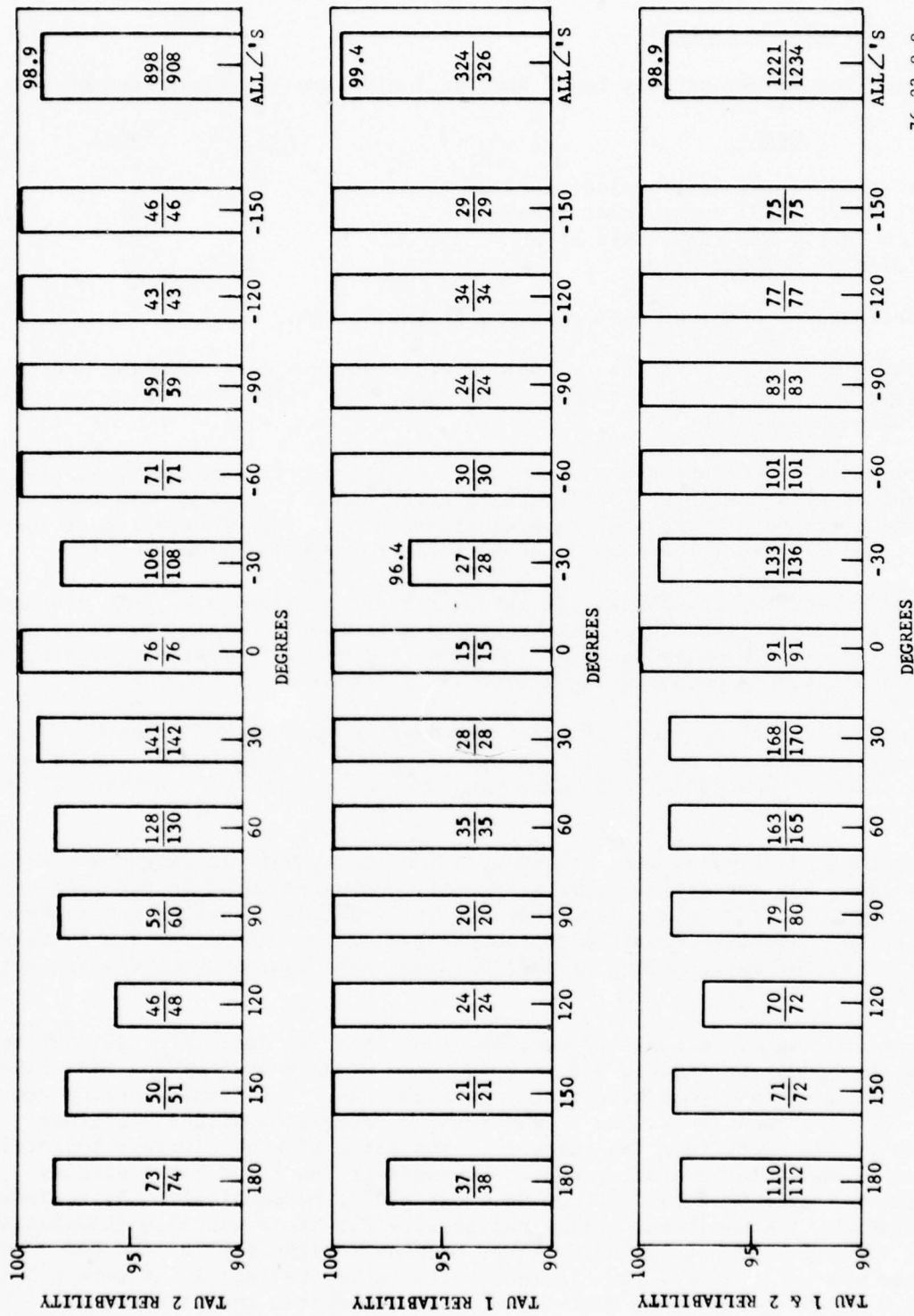

76-23-8-8

FIGURE 8-8. DISPLAY RELIABILITY FOR CAU VS. CAU CONFIGURATION BY ANGLES BETWEEN RADIALS FLOWN

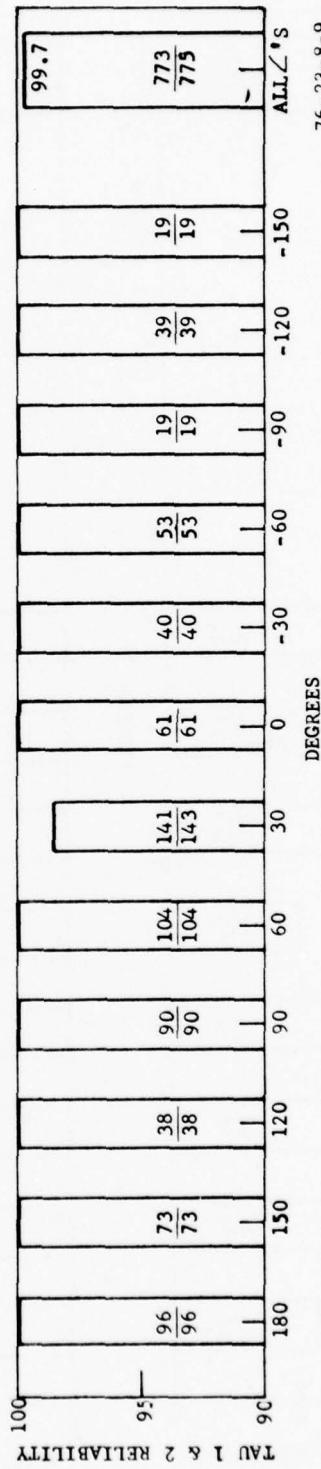
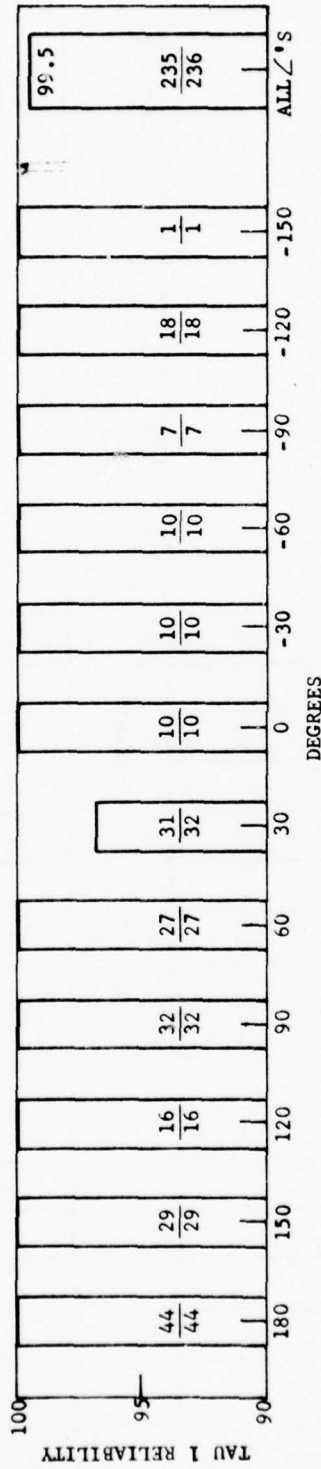
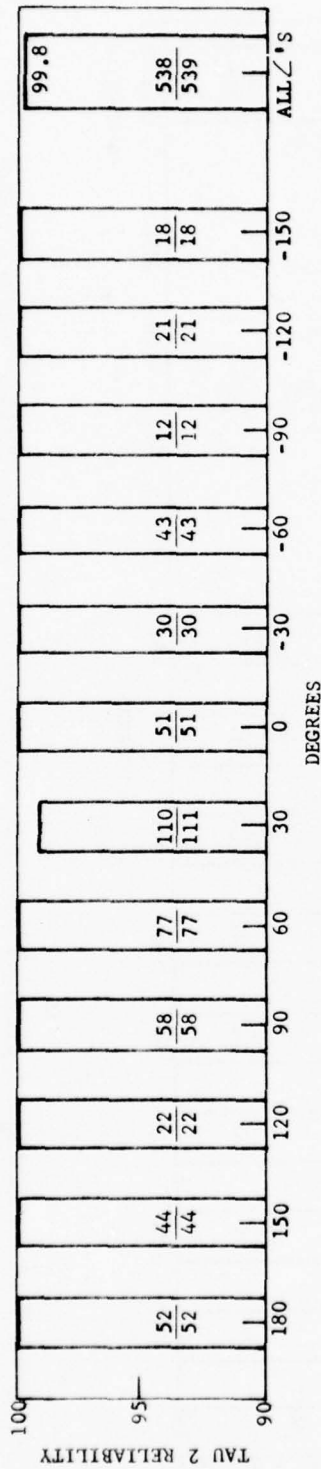

76-23-8-9

FIGURE 8-9. DISPLAY RELIABILITY FOR MINI-CAS VS. MINI-CAS BY ANGLES BETWEEN RADIALS FLOWN

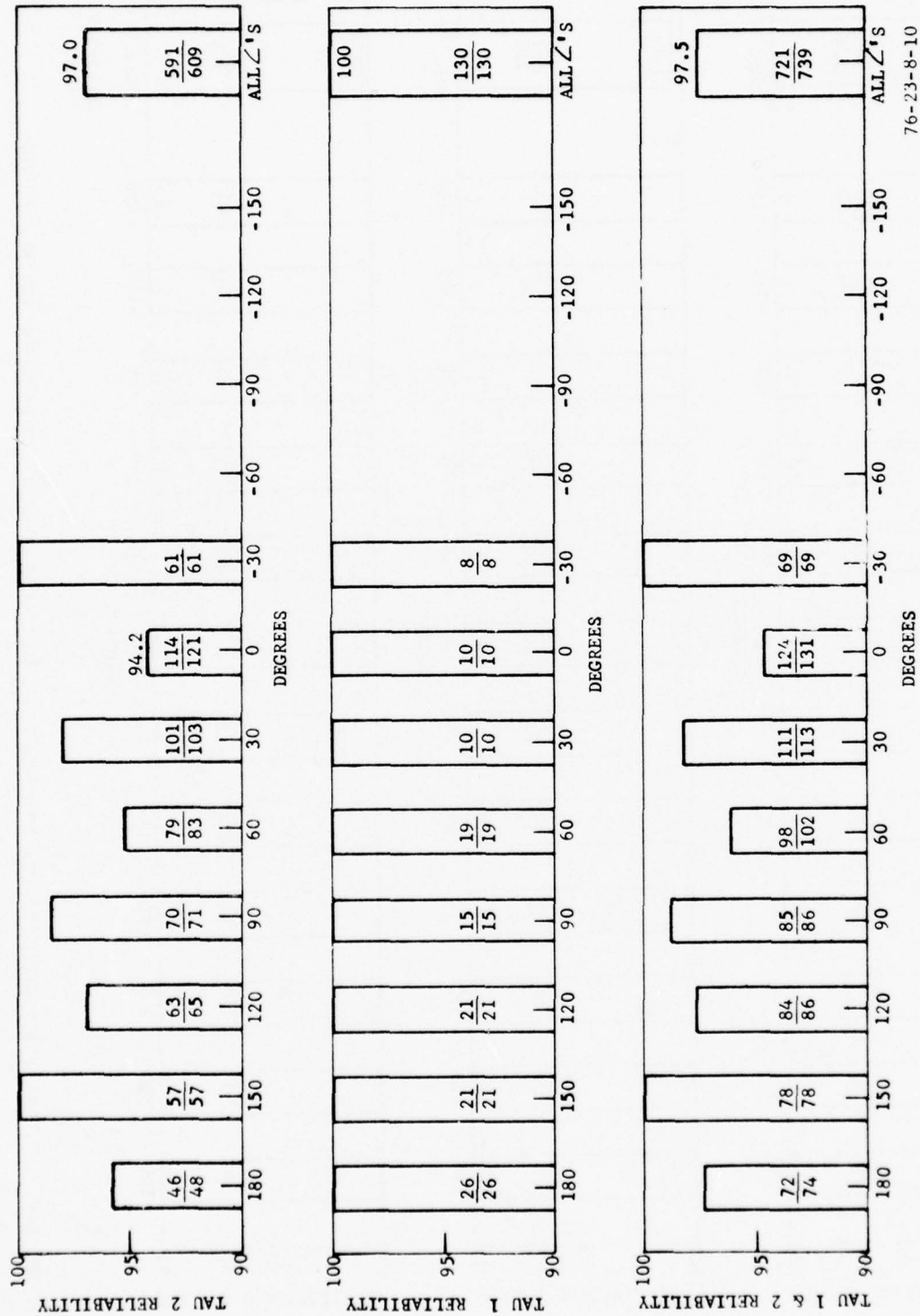

76-23-8-10

FIGURE 8-10. DISPLAY RELIABILITY FOR CAU VS. MINI-CAS BY ANGLES BETWEEN RADIALS FLOWN

## CHAPTER 9

### ALTITUDE BOUNDARIES

The protection envelope or "cocoon" around two approaching aircraft are defined by the altitude and Tau (time to collision) boundaries. Considering only the altitude boundary, the CAS (CAU or Mini-CAS) compares the received altitude data relative to "own altitude data" and classifies an altitude threat as shown in figure 9-1. Aircraft intruding upon the coalatitude zone are considered potential threats, providing the horizontal intrusion falls within the Tau zone. For example, if a coalatitude threat penetrates the Tau 2 boundary, an advisory display is activated, indicating an action may be required shortly. Should the threat continue penetration of the coalatitude band, a Tau 1 maneuver command action is taken. This action may be a climb or dive depending on the threat situation. This sequence is repeated every 3 seconds (epoch) using the altitude and Tau criteria to determine potential threats. Coalatitude band structure is that below 10,000 feet the zone is +600 feet around base altitude, and above 10,000 feet is +800 feet.

The above-below bands each extending an additional 2,500 feet beyond the outer edge of the coalatitude bands are subdivided as shown in figure 9-1. The protection envelope (predicted coalatitude) is increased by the altimeter rate of change when you are climbing or diving. The extension is from the outer edge of the coalatitude band in the direction of altitude rate, when the rate is greater than 500 feet/minute. The height being equal to own-altitude rate-times 30 seconds. Outside of these bands no altitude threat exists.

The CAS equipment compares the received altitude data relative to "own altitude" data. On the basis of this evaluation, the received altitude-coded transmissions (figure 9-2) are sequentially biased to determine occupancy of the altitude threat-status bands in figure 9-1. The CAS evaluates the received altitude data relative to its own altitude, only after a received range pulse is verified. Altitude pulses which arrive 520  $\mu$ s after the leading edge of a range pulse are processed (i.e., received altitude from -1k to 50k feet are processed), as shown in figure 9-2.

The test criteria were to determine the equipment capability to define the altitude boundaries with suitable accuracy. Before each mission, altimeter calibration was performed in flight, to insure a positive altitude separation for aircraft safety. This calibration was made in formation flight (50- to 100-foot separation) during the transit time to the test area. Upon completion, altitude level above and below the base working altitude of the designated aircraft was made to recheck any differences. The flights were flown above and below 10,000 feet for CAU-CAU and below for Mini-CAS-Mini-CAS. The standard pattern flown was a figure eight over the VORTAC. Altitude levels are shown in table 4-4. In examining the individual altitude zone printouts, the main highlights will be to indicate where the Tau 2 advisory or Tau 1 command signals were activated.

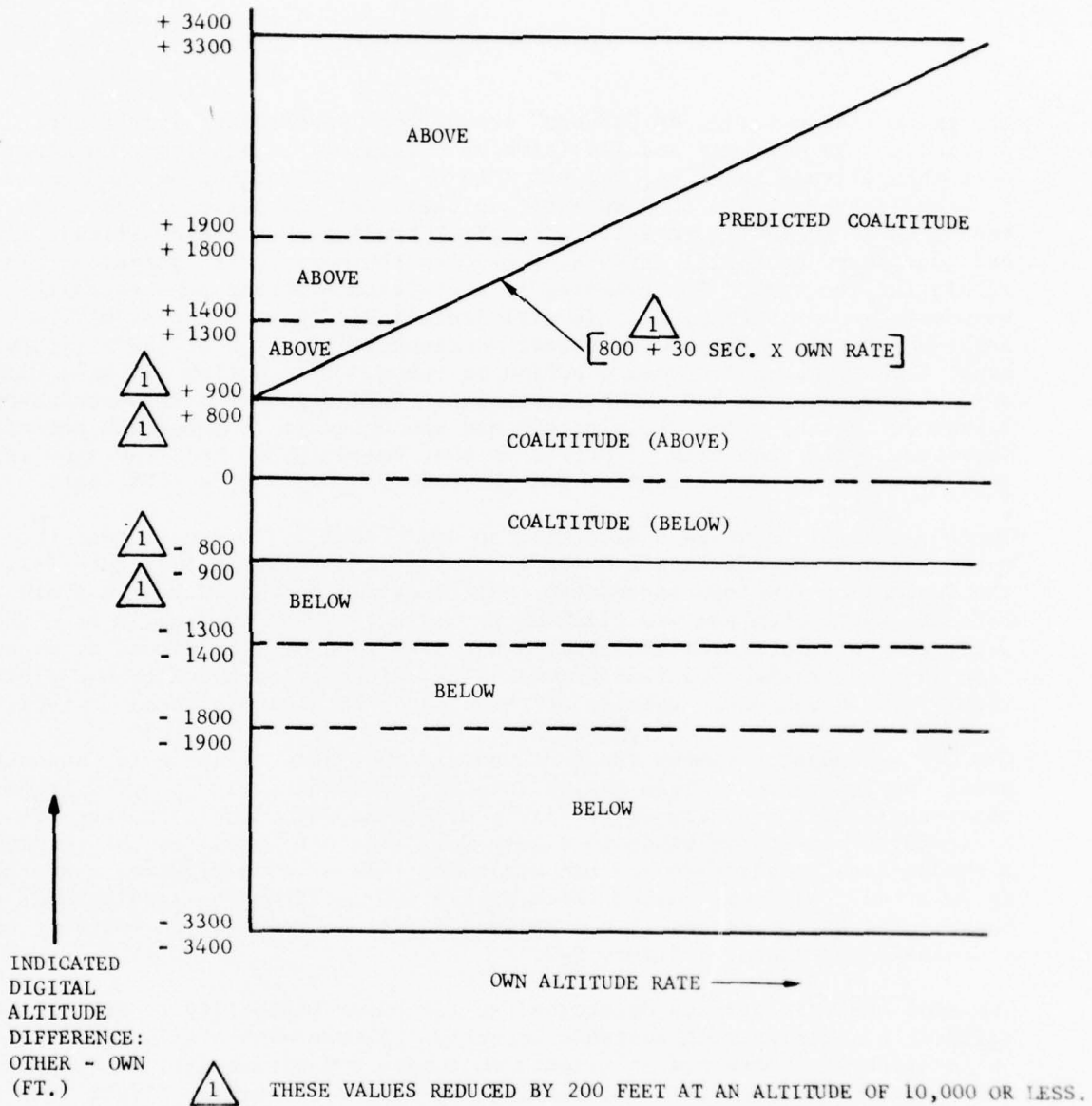

NOTE: PREDICTED COALTITUDE IS EXTENDED ONLY IN DIRECTION OF OWN ALTITUDE RATE. THIS FIGURE ONLY ILLUSTRATES OWN A/C ASCENDING.

76-23-9-1

FIGURE 9-1. THREAT EVALUATION ALTITUDE AND ALTITUDE RATE

ALTITUDE (FT)	DIGITAL CODE										
	D <sub>2</sub>	D <sub>4</sub>	A <sub>1</sub>	A <sub>2</sub>	A <sub>4</sub>	B <sub>1</sub>	B <sub>2</sub>	B <sub>4</sub>	C <sub>1</sub>	C <sub>2</sub>	C <sub>4</sub>
-1000	0	0	0	0	0	0	0	0	0	1	0
-900	0	0	0	0	0	0	0	0	0	1	0
-800	0	0	0	0	0	0	0	0	0	1	0
-700	0	0	0	0	0	0	0	0	0	0	0
-600	0	0	0	0	0	0	0	1	1	1	0
-500	0	0	0	0	0	0	0	1	0	1	0
-400	0	0	0	0	0	0	0	1	0	1	1
-300	0	0	0	0	0	0	0	1	0	0	1
-200	0	0	0	0	0	0	0	1	0	0	1
-100	0	0	0	0	0	0	0	1	0	1	0
000	0	0	0	0	0	0	0	1	0	1	0
100	0	0	0	0	0	0	0	1	1	1	0
200	0	0	0	0	0	0	0	1	1	0	0
300	0	0	0	0	0	0	0	1	0	0	0
400	0	0	0	0	0	0	0	1	0	1	0
500	0	0	0	0	0	0	0	1	0	1	0
600	0	0	0	0	0	0	0	1	0	1	0
700	0	0	0	0	0	0	0	1	0	0	1
800	0	0	0	0	0	0	0	1	0	0	1
900	0	0	0	0	0	0	0	1	0	1	0
1000	0	0	0	0	0	0	0	1	0	1	0
1100	0	0	0	0	0	0	0	1	0	1	0
1200	0	0	0	0	0	0	0	1	0	0	0
1300	0	0	0	0	0	0	0	1	1	0	0
1400	0	0	0	0	0	0	0	1	1	0	0
1500	0	0	0	0	0	0	0	1	1	0	0
1600	0	0	0	0	0	0	0	1	1	0	0
1700	0	0	0	0	0	0	0	1	0	0	0
1800	0	0	0	0	0	0	0	1	0	0	0
1900	0	0	0	0	0	0	0	1	0	1	0
2000	0	0	0	0	0	0	0	1	0	1	0
2100	0	0	0	0	0	0	0	1	0	1	0
2200	0	0	0	0	0	0	0	1	1	0	0
2300	0	0	0	0	0	0	0	1	0	0	0
2400	0	0	0	0	0	0	0	1	0	1	0
2500	0	0	0	0	0	0	0	1	0	1	0
2600	0	0	0	0	0	0	0	1	0	0	1
2700	0	0	0	0	0	0	0	1	0	0	1

THE DIGITAL ALTITUDE IS ENCODED INTO A PULSE POSITION CODE AND TRANSMITTED IN THE CAS MESSAGE AS OWN ALTITUDE. A CHANGE IN THE DIGITAL ALTITUDE OVER A SPECIFIED PERIOD IS USED TO DETERMINE OWN ALTITUDE RATE. THE PRESSURE ALTITUDE IS REFERENCED TO 29.92 in. Hg IN 100 FOOT INCREMENT INPUT TO THE CAS.

FOR EXAMPLE:  
4000 FEET ALTITUDE

ATCRBS CODE D<sub>4</sub> A<sub>1</sub> A<sub>2</sub> A<sub>4</sub> B<sub>1</sub> B<sub>2</sub> B<sub>4</sub> C<sub>1</sub> C<sub>2</sub> C<sub>4</sub>  
0 0 0 1 1 1 1 0 1 0

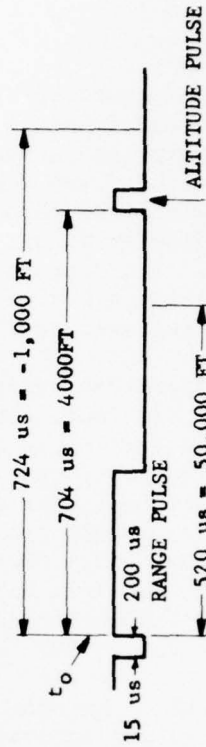

76-23-9-2

FIGURE 9-2. PRESSURE ALTITUDE CODE TRANSMISSION AND EXAMPLE OF THE DIGITAL INPUT TO CAS

Figure 9-3 printout for flight 53, run 6 flown on September 6, 1975, was a test of Mini-CAS in A/C 1 (N377) against another Mini-CAS in A/C 2 (N376). This was a porpoise pattern, changing  $\pm 1,200$  feet from A/C 1 which was flying a base altitude of 7,400 feet. Aircraft were horizontally separated by 500 feet, which was maintained throughout the pattern by using CAS and air-to-air TACAN. The pilots display in A/C 1 on epoch 1157 indicated the outside boundary right on 600 feet. The corresponding display indication came on at epoch 1163 in A/C 2 indicating A/C 1 was below at 700 feet. Both command signals (DIVE/CLIMB) were released at the 700-foot altitude separation point.

Examining figure 9-4, flight 61, run 5, shows the upper limit of the advisory band above 3,300 feet. The equipment in A/C 1 was a CAU; A/C 2 also had a CAU, with the test being flown above 10,000 feet. Continuing with flight 61, figure 9-5 indicates that the 1,800/1,900-foot-above boundary is shown at the top of the printout, while the lower half shows the 1,300/1,400-foot boundary. These boundary levels are displayed on the pilots maneuver indicator as a lighted yellow band. Once a band is activated, the pilot is alerted of an intruder, and to limit his rate of climb or descent as shown in figure 1-18. In the 1,300/1,400-foot case, it would warn the upper aircraft (A/C 2) to limit vertical descent to 500 feet/minute.

Figure 9-6 shows that the band above A/C 1 was reached and the appropriate command signal was activated in each aircraft. The Tau 1 commands were broken at the 800-foot level in each aircraft. Aircraft 2 then received a climb indication to clear the command.

Flight 62, October 6, 1975, was an equipment test of CAU-CAU, utilizing the same aircraft. Figure 9-7 and 9-8 printouts show A/C 2 descending into A/C 1 at a rate of 1,100 feet/minute. The advisories (Tau 2) in each aircraft were activated, in addition to the commands (Tau 1). A/C 2 leveled off at 300 feet at epoch 1393 and then proceeded to climb above A/C 1, which is shown in figure 9-9.

Figure 9-10 is a 3.5-nmi lateral turn-in, separated by 500 feet in altitude; both A/C 1 and A/C 2 were CAU equipped. Aircraft were maneuvered for a turn-in to each other at 3.8 nmi. The advisories and command display were activated in each aircraft, but commands were not obeyed.

Maneuvers in the horizontal plane which generate lateral accelerations are protected against by means of the NO-TURN command. Turning maneuvers have the effect of reducing warning time available to effect an avoidance maneuver. "Worst-case" conditions of turning maneuvers occur when one or both of two aircraft, initially on parallel or slightly convergent courses, turn into the other, with both aircraft at approximately the same speed. The NO-TURN command is initiated at the time corresponding to entry into the Tau 2 zone.

Figure 9-11 is the same pattern as figure 9-10 data except maneuver commands are obeyed. The commands were received at epoch 2341 and obeyed and at epochs 2343 and 2345, respectively. The aircraft were separated by 1,000 feet in altitude, 24 seconds later.

BEST AVAILABLE COPY

FLIGHT 053 RUN 06 05 SEP 75 SEA ISLE  
 A/C 01 MINI N-377 Q-192-1369 A/C 02 MINI N-376 Q-193 0045  
 ALTITUDE ZONE BOUNDARY +-1200 FT

TIME HR:MIN:SEC	TIME HR:MIN:SEC		EPDCH NO	SYNC FLAG	ATCRBS ALT		DAL H FT	MANUEVER IND.		PWF
	A/C 1	A/C 2			A/C 1	A/C 2		A/C 1	A/C 2	
14.27.57.2			1137		7400	7700	1-2	NC512L0512		
14.28.0.2			1138		7400	7800				TACAN 0.1 NMI
14.28.0.2			1139		7400	7800				
14.28.6.2			1140		7400	7800				
14.28.9.2			1141		7400	7800				COMMANDS IN EACH AIRCRAFT WERE ON.
14.28.12.2			1142		7400	7800				
14.28.15.2			1143		7400	7800				
14.28.18.2			1144		7400	7800				
14.28.21.2			1145		7400	7800				
14.28.24.2			1146		7400	7800				
14.28.27.2			1147		7400	7900				
14.28.30.2			1148		7400	7900				
14.28.33.2			1149		7400	7900				
14.28.36.2			1150		7400	7900				
14.28.39.2			1151		7400	7900				
14.28.42.2			1152		7400	7900				
14.28.45.2			1153		7400	7900				
14.28.48.2			1154		7400	7900				
14.28.51.2			1155		7400	8000				
14.28.54.2			1156		7400	8000				
14.28.57.2			1157		7400	8000				
14.29.0.2			1158		7400	8000				A/C 1 ADVISORY ON, INDICATING AIRCRAFT ABOVE AND LIMIT SPEED TO 500 VERTICAL FT/MIN
14.29.3.2			1159		7400	8000				
14.29.6.2			1160		7400	8000				
14.29.9.2			1161		7400	8000				
14.29.12.2			1162		7400	8000				
14.29.15.2			1163		7400	8000				
14.29.18.2			1164		7400	8100				
14.29.21.2			1165		7400	8100				
14.29.24.2			1166		7400	8100				
14.29.27.2			1167		7400	8100				
14.29.30.2			1168		7400	8100				
14.29.33.2			1169		7400	8100				
14.29.36.2			1170		7400	8100				
14.29.39.2			1171		7400	8200				
14.29.42.2			1172		7400	8200				
14.29.45.2			1173		7400	8200				
14.29.48.2			1174		7400	8200				
14.29.51.2			1175		7400	8200				
14.29.54.2			1176		7400	8200				
14.29.57.2			1177		7400	8200				
14.30.0.2			1178		7400	8300				
14.30.3.2			1179		7400	8300				
14.30.6.2			1180		7400	8300				
14.30.9.2			1181		7400	8300				
14.30.12.2			1182		7400	8300				
14.30.15.2			1183		7400	8300				
14.30.18.2			1184		7400	8300				
14.30.21.2			1185		7400	8300				
14.30.24.2			1186		7400	8300				TACAN 0.3 NMI

COMMANDS IN EACH AIRCRAFT WERE TURNED OFF AT 700 FOOT VERTICAL SEPARATION.

76-23-9-3

FIGURE 9-3. ALTITUDE ZONE BOUNDARY COALTITUDE (MINI-CAS VS. MINI-CAS)

BEST AVAILABLE COPY

FLIGHT 061 R/N 005 05 OCT 75  
 A/C 001 CAU N-377 Q-222 1033 A/C 002 CAU N-376 Q-225 0741  
 ALTITUDE ZONE BOUNDARY +600/+3500 FT AT 500 FPM

TIME		EPOCH NO	SYNCH FLAG	ATRRS ALT		DAL H FT	MANUEVER IND.		PWF
HR MN SEC	A/C 1			A/C 2	A/C 1		A/C 2	A/C 1	
11.15.24.1	11.15.24.0	2333	9900	13400	1-3500				
11.15.27.1	11.15.27.0	2334	9900	13500	-3600				
11.15.30.1	11.15.30.0	2335	9900	13500	-3600				
11.15.33.1	11.15.33.0	2336	9900	13500	-3600				
11.15.36.1	11.15.36.0	2337	9900	13500	-3600				
11.15.39.1	11.15.39.0	2338	9900	13600	-3700				
11.15.42.1	11.15.42.0	2339	9900	13600	-3700				
11.15.45.1	11.15.45.0	2340	9900	13600	-3700				
11.15.48.1	11.15.48.0	2341	9900	13600	-3700				
11.15.51.1	11.15.51.0	2342	10000	13700	-3700				
11.15.54.1	11.15.54.0	2343	10000	13700	-3700				
11.15.57.1	11.15.57.0	2344	10000	13700	-3700				
11.16.0.1	11.16.0.0	2345	10000	13700	-3700				
11.16.3.1	11.16.3.0	2346	9900	13700	-3800				
11.16.6.1	11.16.6.0	2347	9900	13700	-3800				
11.16.9.1	11.16.9.0	2348	10000	13700	-3700				
11.16.12.1	11.16.12.0	2349	10000	13700	-3700				
11.16.15.1	11.16.15.0	2350	10000	13700	-3700				
11.16.18.1	11.16.18.0	2351	10000	13700	-3700				
11.16.21.1	11.16.21.0	2352	10000	13600	-3600				
11.16.24.1	11.16.24.0	2353	10000	13600	-3600				
11.16.27.1	11.16.27.0	2354	10000	13600	-3600				
11.16.30.1	11.16.30.0	2355	10000	13600	-3600				
11.16.33.1	11.16.33.0	2356	10000	13600	-3600				
11.16.36.1	11.16.36.0	2357	10000	13500	-3500				
11.16.39.1	11.16.39.0	2358	10000	13500	-3500				
11.16.42.1	11.16.42.0	2359	9900	13500	-3600				
11.16.45.1	11.16.45.0	2360	10000	13500	-3500				
11.16.48.1	11.16.48.0	2361	10000	13500	-3500				
11.16.51.1	11.16.51.0	2362	9900	13400	-3500				
11.16.54.1	11.16.54.0	2363	9900	13400	-3500				
11.16.57.1	11.16.57.0	2364	9900	13400	-3500				
11.17.0.1	11.17.0.0	2365	10000	13400	-3400				
11.17.3.1	11.17.3.0	2366	10000	13400	-3400				
11.17.6.1	11.17.6.0	2367	10000	13300	-3300				
11.17.9.1	11.17.9.0	2368	10000	13300	-3300				
11.17.12.1	11.17.12.0	2369	10000	13300	-3300				
11.17.15.1	11.17.15.0	2370	10000	13300	-3300				
11.17.18.1	11.17.18.0	2371	9900	13300	-3400				
11.17.21.1	11.17.21.0	2372	9900	13200	-3300				
11.17.24.1	11.17.24.0	2373	9900	13200	-3300				
11.17.27.1	11.17.27.0	2374	9900	13200	-3300				
11.17.30.1	11.17.30.0	2375	9900	13200	-3300				
11.17.33.1	11.17.33.0	2376	9900	13100	-3200				
11.17.36.1	11.17.36.0	2377	9900	13100	-3200				
11.17.39.1	11.17.39.0	2378	9900	13100	-3200				
11.17.42.1	11.17.42.0	2379	9900	13100	-3200				
11.17.45.1	11.17.45.0	2380	9900	13100	-3200				
11.17.48.1	11.17.48.0	2381	9900	13000	-3100				
11.17.51.1	11.17.51.0	2382	9900	13000	-3100				

FIGURE 9-4. ALTITUDE ZONE BOUNDARY LEVEL, 3,300/3,400 FEET

76-23-9-4

BEST AVAILABLE COPY

FLIGHT 061 R/N 005 05 OCT 75  
 A/C 001 CAU N-377 Q-225 1033 A/C 002 CAU N-376 Q-235 0741  
 ALTITUDE ZONE BD NEARY +600/+3500 FT AT 500 FPM

TIME	HR. MN. SEC	EPOCH NO	SYNC FLAG	ATCRBS ALT		DAL M		MANUEVER IND.	PWF
				A/C 1	A/C 2	1-2	A/C 1		
11.20.24.1	11.20.24.0	2433		10000	12000	-2000	2	NC512L0512	A/C 2
11.20.27.1	11.20.27.0	2434		10000	12000	-2000	2		A/C 2
11.20.30.1	11.20.30.0	2435		10000	12000	-2000	2		A/C 2
11.20.33.1	11.20.33.0	2436		10000	12000	-2000	2		A/C 2
11.20.36.1	11.20.36.0	2437		10000	11900	-1900	2		A/C 2
11.20.39.1	11.20.39.0	2438		10000	11900	-1900	2		A/C 2
11.20.42.1	11.20.42.0	2439		10000	11900	-1900	2	ADVISORY ON	A/C 2
11.20.45.1	11.20.45.0	2440		10000	11900	-1900	2	1800/1900	A/C 2
11.20.48.1	11.20.48.0	2441		10000	11900	-1900	2		A/C 2
11.20.51.1	11.20.51.0	2442		10000	11900	-1900	2		A/C 2
11.20.54.1	11.20.54.0	2443		10000	11800	-1800	2		A/C 2
11.20.57.1	11.20.57.0	2444		10000	11800	-1800	2		A/C 2
11.21.0.1	11.21.0.0	2445		10000	11800	-1800	2		A/C 2
11.21.3.1	11.21.3.0	2446		10000	11800	-1800	2		A/C 2
11.21.6.1	11.21.6.0	2447		10000	11800	-1800	2		A/C 2
11.21.9.1	11.21.9.0	2448		10000	11800	-1800	2		A/C 2
11.21.12.1	11.21.12.0	2449		10000	11700	-1700	2		A/C 2
11.21.15.1	11.21.15.0	2450		10000	11700	-1700	2		A/C 2
11.21.18.1	11.21.18.0	2451		10000	11700	-1700	2		A/C 2
11.21.21.1	11.21.21.0	2452		10000	11700	-1700	2		A/C 2
11.21.24.1	11.21.24.0	2453		10000	11600	-1600	2		A/C 2
11.21.27.1	11.21.27.0	2454		10000	11600	-1600	2		A/C 2
11.21.30.1	11.21.30.0	2455		10000	11600	-1600	2		A/C 2
11.21.33.1	11.21.33.0	2456		10000	11600	-1600	2		A/C 2
11.21.36.1	11.21.36.0	2457		10000	11600	-1600	2		A/C 2
11.21.39.1	11.21.39.0	2458		10000	11600	-1600	2		A/C 2
11.21.42.1	11.21.42.0	2459		10000	11500	-1500	2		A/C 2
11.21.45.1	11.21.45.0	2460		10000	11500	-1500	2		A/C 2
11.21.48.1	11.21.48.0	2461		10000	11500	-1500	2		A/C 2
11.21.51.1	11.21.51.0	2462		10000	11500	-1500	2		A/C 2
11.21.54.1	11.21.54.0	2463		10000	11500	-1500	2	ADVISORY ON	A/C 2
11.21.57.1	11.21.57.0	2464		10000	11400	-1400	2	1300/1400	A/C 2
11.22.0.1	11.22.0.0	2465		10000	11400	-1400	2		A/C 2
11.22.3.1	11.22.3.0	2466		10000	11400	-1400	2		A/C 2
11.22.6.1	11.22.6.0	2467		10000	11300	-1300	2		A/C 2
11.22.9.1	11.22.9.0	2468		10000	11300	-1300	2		A/C 2
11.22.12.1	11.22.12.0	2469		10000	11300	-1300	2		A/C 2
11.22.15.1	11.22.15.0	2470		10000	11300	-1300	2		A/C 2
11.22.18.1	11.22.18.0	2471		10000	11300	-1300	2		A/C 2
11.22.21.1	11.22.21.0	2472		10000	11300	-1300	2		A/C 2
11.22.24.1	11.22.24.0	2473		10000	11300	-1300	2		A/C 2
11.22.27.1	11.22.27.0	2474		10000	11200	-1200	2		A/C 2
11.22.30.1	11.22.30.0	2475		10000	11200	-1200	2		A/C 2
11.22.33.1	11.22.33.0	2476		10000	11200	-1200	2		A/C 2
11.22.36.1	11.22.36.0	2477		10000	11200	-1200	2		A/C 2
11.22.39.1	11.22.39.0	2478		10000	11100	-1100	2		A/C 2
11.22.42.1	11.22.42.0	2479		10000	11100	-1100	2		A/C 2
11.22.45.1	11.22.45.0	2480		10000	11100	-1100	2		A/C 2
11.22.48.1	11.22.48.0	2481		10000	11100	-1100	2		A/C 2
11.22.51.1	11.22.51.0	2482		10000	11100	-1100	2		A/C 2

76-23-9-5

FIGURE 9-5. ALTITUDE ZONE BOUNDARY LEVEL, 1,800/1,900 AND 1,300/1,400 FEET



FLIGHT 062 RUN 007 '06 OCT 75  
 A/C 001 CAU N-377 0-237 0022 A/C 002 CAU N-376 0-239 0573  
 ALTITUDE ZONE BOUNDARY +300/+350 FT AT 1100 FPM

HR:MM:SS	TIME	EPOCH NO	SYNC FLAG	ATCRS ALT		DAL H FT	MANUEVER IND.	A/C 1		A/C 2		PMF
				A/C 1 FT	A/C 2 FT			A/C 1	A/C 2			
9:45:33.2	0:58:33.2	1295		10300	13000	1-2	NC512LD512	1L	1L			
9:45:36.2	0:58:36.2	1296		10300	13000	-2700		1	1			
9:45:39.2	0:58:39.2	1297		10300	13100	-2800						
9:45:42.2	0:58:42.2	1298		10300	13200	-2900						
9:45:45.2	0:58:45.2	1299		10300	13200	-2900		1L	1L			
9:45:48.2	0:58:48.2	1300		10300	13300	-3000		1L	1L			
9:45:51.2	0:58:51.2	1301		10300	13300	-3000		1L	1L			
9:45:54.2	0:58:54.2	1302		10300	13300	-3000		1L	1L			
9:45:57.2	0:58:57.2	1303		10300	13400	-3100		1L	1L			
9:45:0.2	0:59:0.2	1304		10300	13400	-3100		1L	1L			
9:45:3.2	0:59:3.2	1305		10300	13500	-3200		1L	1L			
9:45:6.2	0:59:6.2	1306		10300	13500	-3200		1L	1L			
9:45:9.2	0:59:9.2	1307		10300	13600	-3300		1L	1L			
9:45:12.2	0:59:12.2	1308		10300	13600	-3300		1L	1L			
9:45:15.2	0:59:15.2	1309		10300	13700	-3400		1L	1L			
9:45:18.2	0:59:18.2	1310		10300	13700	-3400						
9:45:21.2	0:59:21.2	1311		10300	13800	-3500						
9:45:24.2	0:59:24.2	1312		10300	13800	-3500						
9:45:27.2	0:59:27.2	1313		10300	13900	-3600						
9:45:30.2	0:59:30.2	1314		10300	13900	-3600						
9:45:33.2	0:59:33.2	1315		10300	13900	-3600						
9:45:36.2	0:59:36.2	1316		10300	13900	-3600						
9:45:39.2	0:59:39.2	1317		10300	13900	-3600						
9:45:42.2	0:59:42.2	1318		10300	13900	-3600						
9:45:45.2	0:59:45.2	1319		10300	13900	-3600						
9:45:48.2	0:59:48.2	1320		10300	13900	-3600						
9:45:51.2	0:59:51.2	1321		10300	13800	-3500						
9:45:54.2	0:59:54.2	1322		10300	13700	-3400						
9:45:57.2	0:59:57.2	1323		10300	13700	-3400						
10:0:0.2	10:0:0.2	1324		10300	13600	-3300						
10:0:3.2	10:0:3.2	1325		10300	13600	-3300						
10:0:6.2	10:0:6.2	1326		10300	13500	-3200						
10:0:9.2	10:0:9.2	1327		10300	13500	-3200						
10:0:12.2	10:0:12.2	1328		10300	13400	-3100						
10:0:15.2	10:0:15.2	1329		10300	13400	-3100						
10:0:18.2	10:0:18.2	1330		10300	13400	-3100						
10:0:21.2	10:0:21.2	1331		10300	13300	-3000						
10:0:24.2	10:0:24.2	1332		10300	13300	-3000						
10:0:27.2	10:0:27.2	1333		10300	13200	-2900						
10:0:30.2	10:0:30.2	1334		10300	13200	-2900						
10:0:33.2	10:0:33.2	1335		10300	13100	-2800						
10:0:36.2	10:0:36.2	1336		10300	13000	-2700						
10:0:39.2	10:0:39.2	1337		10300	13000	-2700						
10:0:42.2	10:0:42.2	1338		10300	13000	-2700						
10:0:45.2	10:0:45.2	1339		10300	12900	-2600						
10:0:48.2	10:0:48.2	1340		10300	12900	-2600						
10:0:51.2	10:0:51.2	1341		10300	12800	-2500						
10:0:54.2	10:0:54.2	1342		10300	12800	-2500						
10:0:57.2	10:0:57.2	1343		10300	12700	-2400						
10:1:0.2	10:1:0.2	1344		10300	12700	-2400						

A/C 2 DESCENDING INTO A/C 1

ALL ADVISORIES OFF

ADVISORIES ON

76-23-9-7

FIGURE 9-7. ALTITUDE ZONE BOUNDARY, EPOCH 1295 TO 1344

BEST AVAILABLE COPY



FLIGHT 062 RUN 007 06 OCT 75  
 A/C 001 CAU N-377 0-237 0022 A/C 002 CAU N-376 0-239 0573  
 ALTITUDE ZONE BOUNDARY +500/+5500 FT AT 1100 FPM

TIME		EPOCH NO.	SYNC FLAG	ATCRS ALT FT		DAL H FT	MANUEVER IND.		PMF A/C 1 A/C 2
HR	MIN			A/C 1	A/C 2		A/C 1	A/C 2	
10	3.33.2	10	3.33.2	10300	15700	1-2	NC512L0512	NC512L0512	
10	3.36.2	10	3.36.2	10300	1700	-400N	521 D	NC 521	
10	3.39.2	10	3.39.2	10300	1700	-400N	521 D	NC 521	
10	3.42.2	10	3.42.2	10300	1800	-500N	521 D	NC 521	
10	3.45.2	10	3.45.2	10300	1800	-500N	521 D	NC 521	
10	3.48.2	10	3.48.2	10300	1900	-600N	521 D	NC 521	
10	3.51.2	10	3.51.2	10300	1900	-600N	521 D	NC 521	
10	3.54.2	10	3.54.2	10300	1900	-700N	521 D	NC 521	
10	3.57.2	10	3.57.2	10300	1900	-700N	521 D	NC 521	
10	4.0.2	10	4.0.2	10300	1100	-800W	521 D	NC 521	
10	4.3.2	10	4.3.2	10300	1100	-800W	521 D	NC 521	
10	4.6.2	10	4.6.2	10300	1100	-900N	521 D	NC 521	
10	4.9.2	10	4.9.2	10300	1100	-900N	521 D	NC 521	
10	4.12.2	10	4.12.2	10300	1100	-1000	521	NC 521	
10	4.15.2	10	4.15.2	10300	1100	-1000	521	NC 521	
10	4.18.2	10	4.18.2	10300	1100	-1000	521	NC 521	
10	4.21.2	10	4.21.2	10300	1100	-1100	521	NC 521	
10	4.24.2	10	4.24.2	10300	1100	-1100	521	NC 521	
10	4.27.2	10	4.27.2	10300	1100	-1200	521	NC 521	
10	4.30.2	10	4.30.2	10300	1100	-1200	521	NC 521	
10	4.33.2	10	4.33.2	10300	1100	-1300	521	NC 521	
10	4.36.2	10	4.36.2	10300	1100	-1300	521	NC 521	
10	4.39.2	10	4.39.2	10300	1100	-1400	521	NC 521	
10	4.42.2	10	4.42.2	10300	1100	-1400	521	NC 521	
10	4.45.2	10	4.45.2	10300	1100	-1500	21	NC 521	
10	4.48.2	10	4.48.2	10300	1100	-1500	21	NC 521	
10	4.51.2	10	4.51.2	10300	1100	-1600	21	NC 521	
10	4.54.2	10	4.54.2	10300	1200	-1700	21	NC 521	
10	4.57.2	10	4.57.2	10300	1200	-1700	21	NC 521	
10	5.0.2	10	5.0.2	10300	1200	-1800	21	NC 521	
10	5.3.2	10	5.3.2	10300	1200	-1900	21	NC 521	
10	5.6.2	10	5.6.2	10300	1200	-2000	21	NC 521	
10	5.9.2	10	5.9.2	10300	1200	-2000	21	NC 521	
10	5.12.2	10	5.12.2	10300	1200	-2100	1	NC 521	
10	5.15.2	10	5.15.2	10300	1200	-2100	1	NC 521	
10	5.18.2	10	5.18.2	10300	1200	-2200	1	NC 521	
10	5.21.2	10	5.21.2	10300	1200	-2200	1	NC 521	
10	5.24.2	10	5.24.2	10300	1200	-2300	1	NC 521	
10	5.27.2	10	5.27.2	10300	1200	-2300	1	NC 521	
10	5.30.2	10	5.30.2	10300	1200	-2400	1	NC 521	
10	5.33.2	10	5.33.2	10300	1200	-2400	1	NC 521	
10	5.36.2	10	5.36.2	10300	1200	-2500	1	NC 521	
10	5.39.2	10	5.39.2	10300	1200	-2500	1	NC 521	
10	5.42.2	10	5.42.2	10300	1200	-2600	1	NC 521	
10	5.45.2	10	5.45.2	10300	1200	-2600	1	NC 521	
10	5.48.2	10	5.48.2	10300	1200	-2700	1	NC 521	
10	5.51.2	10	5.51.2	10300	1200	-2700	1	NC 521	
10	5.54.2	10	5.54.2	10300	1200	-2800	1	NC 521	
10	5.57.2	10	5.57.2	10300	1200	-2800	1	NC 521	
10	6.0.2	10	6.0.2	10300	1200	-2800	1	NC 521	

↑  
 A/C 2  
 IS CLIMBING  
 AWAY FROM  
 A/C 1

76-23-9-9

FIGURE 9-9. ALTITUDE ZONE BOUNDARY, EPOCH 1395 TO 1444

BEST AVAILABLE COPY

FLIGHT 063 RUN 002 07 OCT 75  
 A/C 01 N-377 Q-241 CAU 1409  
 3.2 NMI LATERAL TURN IN

TIME HR MN SEC	EPOCH NO	SYNC FLAG	ATRRS ALT FT		DAL H FT	MANUEVER IND, A/C 2	A/C 1	A/C 2	PWF A/C 1 A/C 2
			A/C 1	A/C 2					
9:41:15.2	1689		10200	13700	1-2	N	N	512	
9:41:21.2	1691		10200	13700		N	N	512	
9:41:27.2	1693		10200	13700		N	N	512	TACAN 1.2 NMI
9:41:33.2	1695		10200	13700		N	N	512	
9:41:39.2	1697		10200	13700		N	N	512	SLIGHTLY CONVERGING
9:41:45.2	1699		10200	13700		N	N	512	COURSE, "NO TURN" AND
9:41:51.2	1701		10200	13700		N	N	512	ADVISORIES ON,
9:41:57.2	1703		10200	13700		N	N	512	
9:42:03.2	1705		10200	13700		N	N	512	
9:42:09.2	1707		10200	13700		N	N	512	
9:42:15.2	1709		10200	13700		N	N	512	
9:42:21.2	1711		10200	13700		N	N	512	
9:42:27.2	1713		10200	13700		N	N	512	
9:42:33.2	1715		10200	13700		N	N	512	
9:42:39.2	1717		10200	13700		N	N	512	
9:42:45.2	1719		10200	13700		N	N	512	
9:42:51.2	1721		10200	13700		N	N	512	
9:42:57.2	1723		10200	13700		N	N	512	
9:43:03.2	1725		10200	13700		N	N	512	
9:43:09.2	1727		10200	13700		N	N	512	
9:43:15.2	1729		10200	13700		N	N	512	
9:43:21.2	1731		10200	13700		N	N	512	
9:43:27.2	1733		10200	13700		N	N	512	
9:43:33.2	1735		10200	13700		N	N	512	
9:43:39.2	1737		10200	13700		N	N	512	
9:43:45.2	1739		10200	13700		N	N	512	
9:43:51.2	1741		10200	13700		N	N	512	
9:43:57.2	1743		10200	13700		N	N	512	
9:44:03.2	1745		10200	13700		N	N	512	
9:44:09.2	1747		10200	13700		N	N	512	
9:44:15.2	1749		10200	13700		N	N	512	
9:44:21.2	1751		10200	13700		N	N	512	
9:44:27.2	1753		10200	13700		N	N	512	
9:44:33.2	1755		10200	13700		N	N	512	
9:44:39.2	1757		10200	13700		N	N	512	
9:44:45.2	1759		10200	13700		N	N	512	
9:44:51.2	1761		10200	13700		N	N	512	
9:44:57.2	1763		10200	13700		N	N	512	
9:45:03.2	1765		10200	13700		N	N	512	
9:45:09.2	1767		10200	13700		N	N	512	
9:45:15.2	1769		10200	13700		N	N	512	
9:45:21.2	1771		10200	13700		N	N	512	
9:45:27.2	1773		10200	13700		N	N	512	
9:45:33.2	1775		10200	13700		N	N	512	
9:45:39.2	1777		10200	13700		N	N	512	
9:45:45.2	1779		10200	13700		N	N	512	
9:45:51.2	1781		10200	13700		N	N	512	
9:45:57.2	1783		10200	13700		N	N	512	

TACAN 1.2 NMI  
 SLIGHTLY CONVERGING  
 COURSE, "NO TURN" AND  
 ADVISORIES ON,  
 AIRCRAFT DIVERGING  
 ADVISORY BROKEN, A/C  
 SEPARATED BEYOND 1.8 NMI  
 AIRCRAFT TURN IN  
 AT 3.5 NMI  
 TAU 2  
 ADVISORIES ON,  
 NO TURN ON  
 AT 2.8 NMI  
 TAU 1  
 COMMANDS ON  
 AT 1.84 NMI  
 BEYOND 2.3 NMI  
 + AIRCRAFT SEPARATING

76-23-9-10

FIGURE 9-10. LATERAL TURN-IN, EPOCH 1689 TO 1783

FLIGHT 063 RUN 306 07 OCT 75  
 A/C 1 N-377 0-241 CALL 1409  
 3.5 NMI LATERAL TURN IN

HR	MN	SEC	TIME	EPOCH NO	SYAC FLAG	AT/935 ALT		DAL FT	MANEUVER INC, A/C 2		PWF
						A/C 1	A/C 2		A/C 1	A/C 2	
10	10	45.2	10.10.45.2	2279		10200	15700	1-2	C512L0512		
10	10	51.2	10.10.51.2	2281		10200	15700	-500			
10	10	57.2	10.10.57.2	2283		10200	15700	-500			
10	11	3.2	10.11.3.2	2285		10200	15700	-500			
10	11	9.2	10.11.9.2	2287		10200	15700	-500			
10	11	15.2	10.11.15.2	2289		10200	15700	-500			
10	11	21.2	10.11.21.2	2291		10200	15700	-500			
10	11	27.2	10.11.27.2	2293		10200	15700	-500			
10	11	33.2	10.11.33.2	2295		10200	15700	-500			
10	11	39.2	10.11.39.2	2297		10200	15700	-500			
10	11	45.2	10.11.45.2	2299		10200	15700	-500			
10	11	51.2	10.11.51.2	2301		10200	15700	-500			
10	11	57.2	10.11.57.2	2303		10200	15700	-500			
10	12	3.2	10.12.3.2	2305		10200	15700	-500			
10	12	9.2	10.12.9.2	2307		10200	15700	-500			
10	12	15.2	10.12.15.2	2309		10200	15700	-500			
10	12	21.2	10.12.21.2	2311		10200	15700	-500			
10	12	27.2	10.12.27.2	2313		10200	15700	-500			
10	12	33.2	10.12.33.2	2315		10200	15700	-500			
10	12	39.2	10.12.39.2	2317		10200	15700	-500			
10	12	45.2	10.12.45.2	2319		10200	15700	-500			
10	12	51.2	10.12.51.2	2321		10200	15700	-500			
10	12	57.2	10.12.57.2	2323		10200	15700	-500			
10	13	3.2	10.13.3.2	2325		10200	15700	-500			
10	13	9.2	10.13.9.2	2327		10200	15700	-500			
10	13	15.2	10.13.15.2	2329		10200	15700	-500			
10	13	21.2	10.13.21.2	2331		10200	15700	-500			
10	13	27.2	10.13.27.2	2333		10100	15700	-600	512		
10	13	33.2	10.13.33.2	2335		10100	15700	-600	512		
10	13	39.2	10.13.39.2	2337		10100	15700	-600	512		
10	13	45.2	10.13.45.2	2339		10200	15700	-500	512		
10	13	51.2	10.13.51.2	2341		10200	15700	-500	512		
10	13	57.2	10.13.57.2	2343		10100	15700	-600	512		
10	14	3.2	10.14.3.2	2345		10000	15800	-600	512		
10	14	9.2	10.14.9.2	2347		9900	15800	-600	512		
10	14	15.2	10.14.15.2	2349		9900	15900	-1000	512		
10	14	21.2	10.14.21.2	2351		9900	15900	-1000	512		
10	14	27.2	10.14.27.2	2353		9900	15900	-1000	512		
10	14	33.2	10.14.33.2	2355		9900	15900	-1000	512		
10	14	39.2	10.14.39.2	2357		10000	11000	-1000	512		
10	14	45.2	10.14.45.2	2359		10000	11000	-1000	512		
10	14	51.2	10.14.51.2	2361		10000	11100	-1100	512		

AIRCRAFT TURN IN AT 3.95 NMI

TAU 2 ADVISORY AND NO TURN ON AT 3.05 NMI

TAU 1 MANEUVER COMMANDS ON AT 1.79 NMI

BEYOND + 1.8 NMI AIRCRAFT SEPARATING

ALTITUDE SEPARATION OF 1,000 FT IN 24 SECONDS AFTER COMMANDS WERE INITIATED.

A/C 1 OBEYING COMMAND

A/C 2 OBEYING COMMAND

76-23-9-11

FIGURE 9-11. LATERAL TURN-IN, EPOCH 2279 TO 2361

Figure 9-12, flight 54, September 8, 1975, is a lateral crossover test using Mini-CAS equipment aboard each aircraft. Aircraft were separated by 500 feet and parallel to each other at 3.8 nmi. Each aircraft then maneuvered toward the other and crossover of 500 feet was recorded. Aircraft maneuver commands and advisories were generated, although no commands were followed.

Figure 9-13, flight 64, run 6, October 8, 1975, was a dive test using a Mini-CAS on each aircraft. A/C 2 was at 8,000 feet as the maneuvering aircraft, while A/C 1 remained at 5,600 feet. The pattern was a standard figure eight-head-on. With A/C 2 at 2.8-nmi DME from the station, it started a 1,000-foot/minute descent. At the same time, A/C 1 was at the 2.8-nmi DME from the station. A/C 1 then started its descent with the pilot observing the altitude limit commands. As seen in the printout, limit vertical speed of 500 feet/minute was generated, along with command signal of "dive" in A/C 1 and "climb" in A/C 2. Commands were also obeyed, as the closest approach point was 400 feet in altitude, with a TACAN air-to-air (TA-A) range of .45 nmi. Figure 9-14, run 10 was a climb test, with A/C 1 climbing toward A/C 2 and following all advisories and commands. The altitude rate in both cases was greater than the 1,000 feet/minute restriction, and all maneuvers were carried out safely.

Maneuvers in the vertical plane (climbs or dives) are regulated by means of the "level off" command or "limit vertical speed" display signal. In the case of the CAU, the "level off" command is generated by use of own altitude rate and a comparison of altitude difference with the predicted co-altitude zone. It examines the altitude threat by comparing transmitting aircraft altitude data relative to own aircraft altitude data, on this basis it classifies a threat as shown in figure 9-1.

Figure 9-15, flight 64, run 18, was a continuation of the flight, with A/C 2 being reconfigured for a CAU. The altitude zones were probed with A/C 1 climbing toward A/C 2, which maintained a base altitude of 8,700 feet. Altitude separation was limited to 800 feet, and with the logic set for 600 feet. Below 10,000 feet the commands were not activated.

Flight 65, figure 9-16, October 10, 1975, was a test of the above/below altitude threat logic. CAS configuration was a CAU-CAU, with A/C 2 descending into A/C 1 at approximately 2,000 feet/minute. The advisories (limit vertical speed) along with a "level off" command were generated. A/C 2 followed all commands and flew a level flight course for 24 seconds and then proceeded to climb for the next pattern encounter. A "level off" command is utilized to command an aircraft to stop the climb or descent in 10 seconds when the CAS system detects that the protected altitude band possesses a Tau or minimum range threat. The vertical threat evaluation is based on the assumption that the other aircraft is in the predicted coaltitude band.

Altitude zone boundary-type flights involving (lateral turn-in, climbing, diving parallel Tau zone) on each equipment type were flown over 10 flight periods successfully. A sample of the printouts are included for discussion in this chapter.

FLIGHT 054 RUN 004 08 SEP 75 A/C 002 MINI Q-195 0101  
 A/C 001 MINI Q-194 0473  
 LATERAL CROSSING OVER W. C.

HR	MIN	SEC	TIME	HR	MIN	SEC	EPOCH	SYNC	ATCRS	ALT	DAL	H	MANUEVER	IND.	A/C	2	A/C	1	PMF	
A/C	1	A/C	2	NO	1	2	NO	FLAG	FT	FT	FT	FT	IND.	IND.	1	2	1	1	A/C	
14	7	54	2	14	7	54	1088		7200	7700	1-2	NC512LD512	NC512LD512	A/C 2	A/C 2	A/C 1	A/C 2			
14	7	57	2	14	7	57	1089		7200	7700	-500									
14	8	0	2	14	8	0	1090		7200	7700	-500									TACAN 3.88 NMI
14	8	3	2	14	8	3	1091		7200	7700	-500									
14	8	6	2	14	8	6	1092		7200	7700	-500									
14	8	9	2	14	8	9	1093		7200	7700	-500									
14	8	12	2	14	8	12	1094		7200	7700	-500									
14	8	15	2	14	8	15	1095		7200	7700	-500									
14	8	18	2	14	8	18	1096		7200	7600	-400	5								TAU 2
14	8	21	2	14	8	21	1097		7200	7700	-500	5								ADVISORIES ON, TACAN 3.32 NMI
14	8	24	2	14	8	24	1098		7200	7700	-500	5								
14	8	27	2	14	8	27	1099		7200	7700	-500	5								
14	8	30	2	14	8	30	1100		7200	7700	-500	5								
14	8	33	2	14	8	33	1101		7200	7700	-500	5								
14	8	36	2	14	8	36	1102		7200	7700	-500	5								
14	8	39	2	14	8	39	1103		7200	7700	-500	5								
14	8	42	2	14	8	42	1104		7200	7700	-500	5								
14	8	45	2	14	8	45	1105		7200	7700	-500	5								
14	8	48	2	14	8	48	1106		7200	7700	-500	5								
14	8	51	2	14	8	51	1107		7200	7700	-500	5								
14	8	54	2	14	8	54	1108		7200	7600	-400	5								
14	8	57	2	14	8	57	1109		7200	7600	-400	5								
14	9	0	2	14	9	0	1110		7200	7700	-500	5								
14	9	3	2	14	9	3	1111		7200	7700	-500	5								
14	9	6	2	14	9	6	1112		7200	7700	-500	5								
14	9	9	2	14	9	9	1113		7200	7700	-500	5								
14	9	12	2	14	9	12	1114		7200	7700	-500	5								
14	9	15	2	14	9	15	1115		7200	7700	-500	5								
14	9	18	2	14	9	18	1116		7200	7700	-500	5								
14	9	21	2	14	9	21	1117		7200	7700	-500	5								
14	9	24	2	14	9	24	1118		7200	7600	-400	5								
14	9	27	2	14	9	27	1119		7200	7600	-400	5								
14	9	30	2	14	9	30	1120		7200	7600	-400	5								
14	9	33	2	14	9	33	1121		7200	7700	-500	5								
14	9	36	2	14	9	36	1122		7200	7700	-500	5								
14	9	39	2	14	9	39	1123		7200	7700	-500	5								
14	9	42	2	14	9	42	1124		7300	7800	-500	5								

76-23-9-12

FIGURE 9-12. LATERAL CROSSOVER, LOWER FLIGHT TURNING

BEST AVAILABLE COPY

FLIGHT 064 RUM 005 08 OCT 75 A/C 02 N-376 MINI 1953 0-231  
 A/C 01 N-377 MINI 0881 0-247 A/C 03 N-378 MINI 1000 DV 600 N-377 LVL AT 6000 N-376 DIVE  
 CLIMB/DIVE 400 FT CLST LMT CLMB 1000 DV 600 N-377 LVL AT 6000 N-376 DIVE

TIME		EPDCH NO	SYNC FLAG	ATCRBS ALT		DAL H		MANUEVER IND.		PWF	
HR	MIN			SEC	A/C 1	A/C 2	FT	A/C 1	A/C 2	A/C 1	A/C 2
9.32	3.2	10.12.3.2	*	5600	7400	-1800					
9.32	9.2	10.12.9.2	*	5600	7300	-1700					
9.32	15.2	10.12.15.2	*	5600	7100	-1500					
9.32	21.2	10.12.21.2	*	5600	6900	-1300					
9.32	27.2	10.12.27.2	*	5600	6800	-1200					
9.32	33.2	10.12.33.2	*	5600	6600	-1000					
9.32	39.2	10.12.39.2	*	5600	6400	-800					
9.32	45.2	10.12.45.2	*	5600	6200	-600					
9.32	51.2	10.12.51.2	*	5600	6000	-400					
9.32	57.2	10.12.57.2	*	5600	6100	-500					
9.33	3.2	10.13.3.2	*	5600	6200	-600					
9.33	9.2	10.13.9.2	*	5600	6300	-700					
9.33	15.2	10.13.15.2	*	5600	6400	-800					
9.33	21.2	10.13.21.2	*	5600	6500	-900					
9.33	27.2	10.13.27.2	*	5600	6600	-1000					
9.33	33.2	10.13.33.2	*	5600	6700	-1100					
9.33	39.2	10.13.39.2	*	5600	6800	-1200					
9.33	45.2	10.13.45.2	*	5600	6800	-1200					
9.33	51.2	10.13.51.2	*	5600	6800	-1200					
9.33	57.2	10.13.57.2	*	5600	6800	-1200					
9.34	3.2	10.14.3.2	*	5600	6900	-1300					
9.34	9.2	10.14.9.2	*	5600	7000	-1400					
9.34	15.2	10.14.15.2	*	5600	7100	-1500					
9.34	21.2	10.14.21.2	*	5600	7200	-1600					
9.34	27.2	10.14.27.2	*	5600	7300	-1700					
9.34	33.2	10.14.33.2	*	5600	7400	-1800					
9.34	39.2	10.14.39.2	*	5600	7500	-1900					
9.34	45.2	10.14.45.2	*	5600	7600	-2000					
9.34	51.2	10.14.51.2	*	5600	7600	-2000					
9.34	57.2	10.14.57.2	*	5600	7700	-2100					
9.35	3.2	10.15.3.2	*	5600	7800	-2200					
9.35	9.2	10.15.9.2	*	5600	7700	-2100					
9.35	15.2	10.15.15.2	*	5600	7700	-2100					
9.35	21.2	10.15.21.2	*	5600	7700	-2100					
9.35	27.2	10.15.27.2	*	5600	7700	-2100					
9.35	33.2	10.15.33.2	*	5600	7700	-2100					

MANUEVER IND. A/C 1 A/C 2  
 NC512LD512 NC512LD512  
 TAU 1 TAU 2  
 ADVISORIES ON  
 LIMIT VERTICAL SPEED  
 THREAT CLEARED  
 COMMANDS TO TAKE  
 EVASIVE ACTION

76-23-9-13

FIGURE 9-13. DIVE (MINI-CAS VS. MINI-CAS) BELOW 10,000 FEET

FLIGHT 066 RUN.DIG 08 OCT 75  
 - A/C 01 N-377 MINI 0081 Q-267 A/C 02 N-376 MINI 1953 Q-251  
 CLIMB/DIVE 600 FT CLST LMT CLMB 1000 DV 600 N-376 LVL AT 8000 N-376 CLMB

TIME		EPOCH NO		SYNC FLAG	ATCRBS ALT		DAL H		MANUEVER IND.		PWF	
HR	MN	SEC	HR	MN	SEC	A/C 1	A/C 2	FT	A/C 1	A/C 2	A/C 1	A/C 2
9.55.39.2	9.55.39.2	1176	9.55.39.2		5600	7700	-2100	1-2	NC912LD312	NC912LD512		
9.55.45.2	9.55.45.2	1178	9.55.45.2		5600	7700	-2100					
9.55.51.2	9.55.51.2	1180	9.55.51.2		5600	7700	-2100					
9.55.57.2	9.55.57.2	1182	9.55.57.2		5600	7700	-2100					
9.56.03.2	9.56.03.2	1184	9.56.03.2		5600	7700	-2100					
9.56.09.2	9.56.09.2	1186	9.56.09.2		5600	7700	-2100					
9.56.15.2	9.56.15.2	1188	9.56.15.2		5600	7700	-2100					
9.56.21.2	9.56.21.2	1190	9.56.21.2		5500	7700	-2200					
9.56.27.2	9.56.27.2	1192	9.56.27.2		5500	7700	-2200					
9.56.33.2	9.56.33.2	1194	9.56.33.2		5500	7700	-2200					
9.56.39.2	9.56.39.2	1196	9.56.39.2		5600	7700	-2100					
9.56.45.2	9.56.45.2	1198	9.56.45.2		5700	7700	-2000					
9.56.51.2	9.56.51.2	1200	9.56.51.2		5900	7700	-1800					
9.56.57.2	9.56.57.2	1202	9.56.57.2		6100	7700	-1600					
9.57.03.2	9.57.03.2	1204	9.57.03.2		6300	7700	-1400					
9.57.09.2	9.57.09.2	1206	9.57.09.2		6300	7700	-1400					
9.57.15.2	9.57.15.2	1208	9.57.15.2		6700	7700	-1000					
9.57.21.2	9.57.21.2	1210	9.57.21.2		6900	7700	-800					
9.57.27.2	9.57.27.2	1212	9.57.27.2		7100	7700	-600					
9.57.33.2	9.57.33.2	1214	9.57.33.2		7000	7700	-700					
9.57.39.2	9.57.39.2	1216	9.57.39.2		6800	7700	-900					
9.57.45.2	9.57.45.2	1218	9.57.45.2		6800	7700	-900					
9.57.51.2	9.57.51.2	1220	9.57.51.2		6500	7800	-1300					
9.57.57.2	9.57.57.2	1222	9.57.57.2		6400	7800	-1400					
9.58.03.2	9.58.03.2	1224	9.58.03.2		6200	7700	-1500					
9.58.09.2	9.58.09.2	1226	9.58.09.2		6000	7700	-1700					
9.58.15.2	9.58.15.2	1228	9.58.15.2		5900	7700	-1800					
9.58.21.2	9.58.21.2	1230	9.58.21.2		5900	7700	-1800					
9.58.27.2	9.58.27.2	1232	9.58.27.2		5900	7800	-1900					
9.58.33.2	9.58.33.2	1234	9.58.33.2		5800	7800	-2000					

TAU 2, LIMIT VERTICAL SPEED TO 500 FT/MIN

AIRCRAFT BELOW

TAU 1 COMMAND

TACAN = 1.64 NMI

TACAN = 0.4 NMI

THREAT CLEARED

TACAN = 1.1 NMI

76-23-9-14

FIGURE 9-14. CLIMB (MINI-CAS VS. MINI-CAS) BELOW 10,000 FEET

FLIGHT 064 RUA 018 08 OCT 75 A/C 02 N-376 CAU 1083 Q-249  
 A/C 01 N-377 (MI) 0081 Q-247 A/C 02 N-376 CAU 1083 Q-249  
 CLIMB/DIVE 700 FT CLOSEST LIMIT CLIMB 1000 FT

TIME		EPDM NO	SYN FLAG	ATCRBS ALT		DAL H FT	MANUEVER IND.		PnF	
HR	MI			SEC	HR		MI	SEC		A/C 1
11.25	0.2	11.25.0.2	876			5600	A/C 2	700		
11.25	6.2	11.25.6.2	878			5600	A/C 2	8700		
11.25	17.2	11.25.17.2	880			5600	A/C 2	8700		
11.25	18.2	11.25.18.2	882			5600	A/C 2	8700		
11.25	24.2	11.25.24.2	884			5600	A/C 2	8700		
11.25	30.2	11.25.30.2	886			5600	A/C 2	8700		
11.25	30.2	11.25.30.2	888			5600	A/C 2	8700		
11.25	42.2	11.25.42.2	890			5600	A/C 2	8700		
11.25	48.2	11.25.48.2	892			5600	A/C 2	8700		
11.25	54.2	11.25.54.2	894			5600	A/C 2	8700		
11.25	0.2	11.26.0.2	896			5600	A/C 2	8700		
11.25	6.2	11.26.6.2	898			5900	A/C 2	8700		
11.25	12.2	11.26.12.2	900			6300	A/C 2	8700		
11.25	18.2	11.26.18.2	902			6600	A/C 2	8700		
11.25	24.2	11.26.24.2	904			6900	A/C 2	8700		
11.25	30.2	11.26.30.2	906			7100	A/C 2	8700		
11.25	36.2	11.26.36.2	908			7300	A/C 2	8700		
11.25	42.2	11.26.42.2	910			7500	A/C 2	8700		
11.25	48.2	11.26.48.2	912			7500	A/C 2	8700		
11.25	54.2	11.26.54.2	914			7900	A/C 2	8700		
11.27	0.2	11.27.0.2	916			7900	A/C 2	8700		
11.27	6.2	11.27.6.2	918			7900	A/C 2	8700		
11.27	12.2	11.27.12.2	920			8000	A/C 2	8700		
11.27	18.2	11.27.18.2	922			7900	A/C 2	8700		
11.27	24.2	11.27.24.2	924			7610	A/C 2	8700		
11.27	30.2	11.27.30.2	926			7300	A/C 2	8700		
11.27	36.2	11.27.36.2	928			7200	A/C 2	8700		
11.27	42.2	11.27.42.2	930			7100	A/C 2	8700		
11.27	48.2	11.27.48.2	932			7000	A/C 2	8700		
11.27	54.2	11.27.54.2	934			6800	A/C 2	8700		
11.28	0.2	11.28.0.2	936			6800	A/C 2	8700		
11.28	6.2	11.28.6.2	938			6700	A/C 2	8700		
11.28	12.2	11.28.12.2	940			6500	A/C 2	8700		
11.28	18.2	11.28.18.2	942			6400	A/C 2	8700		
11.28	24.2	11.28.24.2	944			6300	A/C 2	8700		
11.28	30.2	11.28.30.2	946			6200	A/C 2	8700		
11.28	36.2	11.28.36.2	948			6100	A/C 2	8700		
11.28	42.2	11.28.42.2	950			6000	A/C 2	8700		
11.28	48.2	11.28.48.2	952			5900	A/C 2	8700		
11.28	54.2	11.28.54.2	954			5700	A/C 2	8700		

FIGURE 9-15. CLIMB (MINI-CAS VS. CAU) BELOW 10,000 FEET

FLIGHT 065 RUN 003 10 OCT 75  
 A/C 01 N-377 CAU Q-260 1227 A/C 02 N-376 CAU Q-254 0131  
 A/C 1 LVL A/C 2 DIVE 500 FT CLOSEST 900 LIMIT

TIME		EPDCH NO	SYNC FLAG	ATCRBS ALT		DAL H FT	MANUEVER IND.	A/C 2 NC512L0312	A/C 1 NC512L0512	PHF A/C 1 A/C 2
HR:MN:SEC	HR:MN:SEC			A/C 1	A/C 2					
9:34:02	9:34:02	703		9200	12300	-3100				
9:34:03	9:34:03	704		9200	12300	-3100				
9:34:04	9:34:04	705		9200	12300	-3100				
9:34:05	9:34:05	706		9200	12300	-3100				
9:34:06	9:34:06	707		9200	12300	-3100				
9:34:07	9:34:07	708		9200	12300	-3100				
9:34:08	9:34:08	709		9200	12300	-3100				
9:34:09	9:34:09	710		9200	12300	-3100				
9:34:10	9:34:10	711		9200	12300	-3100				
9:34:11	9:34:11	712		9200	12300	-3100				
9:34:12	9:34:12	713		9200	12300	-3100				
9:34:13	9:34:13	714		9200	12300	-3100				
9:34:14	9:34:14	715		9200	12300	-3100				
9:34:15	9:34:15	716		9200	12300	-3100				
9:34:16	9:34:16	717		9200	12300	-3100				
9:34:17	9:34:17	718		9200	12300	-3100				
9:34:18	9:34:18	719		9200	12300	-3100				
9:34:19	9:34:19	720		9200	12300	-3100				
9:34:20	9:34:20	721		9200	12300	-3100				
9:34:21	9:34:21	722		9200	12300	-3100				
9:34:22	9:34:22	723		9200	12300	-3100				
9:34:23	9:34:23	724		9200	12300	-3100				
9:34:24	9:34:24	725		9200	12300	-3100				
9:34:25	9:34:25	726		9200	12300	-3100				
9:34:26	9:34:26	727		9200	12300	-3100				
9:34:27	9:34:27	728		9200	12300	-3100				
9:34:28	9:34:28	729		9200	12300	-3100				
9:34:29	9:34:29	730		9200	12300	-3100				
9:34:30	9:34:30	731		9200	12300	-3100				
9:34:31	9:34:31	732		9200	12300	-3100				
9:34:32	9:34:32	733		9200	12300	-3100				
9:34:33	9:34:33	734		9200	12300	-3100				
9:34:34	9:34:34	735		9200	12300	-3100				
9:34:35	9:34:35	736		9200	12300	-3100				
9:34:36	9:34:36	737		9200	12300	-3100				
9:34:37	9:34:37	738		9200	12300	-3100				
9:34:38	9:34:38	739		9200	12300	-3100				
9:34:39	9:34:39	740		9200	12300	-3100				
9:34:40	9:34:40	741		9200	12300	-3100				
9:34:41	9:34:41	742		9200	12300	-3100				
9:34:42	9:34:42	743		9200	12300	-3100				
9:34:43	9:34:43	744		9200	12300	-3100				
9:34:44	9:34:44	745		9200	12300	-3100				
9:34:45	9:34:45	746		9200	12300	-3100				
9:34:46	9:34:46	747		9200	12300	-3100				
9:34:47	9:34:47	748		9200	12300	-3100				
9:34:48	9:34:48	749		9200	12300	-3100				
9:34:49	9:34:49	750		9200	12300	-3100				
9:34:50	9:34:50	751		9200	12300	-3100				
9:34:51	9:34:51	752		9200	12300	-3100				

A/C 1 LEVEL FLIGHT  
 A/C 2 DIVING VERTICAL  
 SPEED 1,700 FT/MIN

ADVISORIES ON TO  
 LIMIT VERTICAL SPEED.

LEVEL OFF COMMAND  
 TACAN=2.74 NMI

A/C 2 CLIMBING

TACAN=0.8 NMI

76-23-9-16

FIGURE 9-16. DIVE (CAU VS. CAU) ABOVE/BELOW 10,000 FEET

BEST AVAILABLE COPY

## CHAPTER 10

### NOTES AND OBSERVATIONS

#### 1. MINI-CAS 1 DETERIORATION OF RECEIVER SENSITIVITY.

During interference testing on September 13, 1975, at the CAS/Ground Station, Mini-CAS 1 was left with an open antenna cable (no load) and the limiter was blown out. A replacement limiter was installed and a new receiver sensitivity reading was recorded. This unit never did come back to its original sensitivity figure.

The combined flight and laboratory time of operation was recorded as follows:

CAU 1 = 1,134 hours, CAU 2 = 835 hours.

Recording of each equipment was by an internal power-actuated time meter.

#### 2. CAU BENCH TEST.

On June 27, 1975, CAU 1 had no transmitter power output, and the receiver would not accept sync from the ground station transmissions. It was determined that the exciter was at fault and had to be replaced (appendix C). Exciter S/N 01 was replaced with spare exciter S/N 03 (original one was delivered in October 1975 and sent back for repair in February 1975).

CAU 1 deteriorated from this point on, possibly due to a soft failing in the transmitter output tube, in addition to exciter drive.

#### 3. CAU 1 POWER OUTPUT DROP.

Power output on CAU 1 can be attributed to the power tube going soft after the extended operation of more than 1,100 hours. This gradual decline is normally expected. Although the CAU has an automatic cutoff if the power level approaches 250 W  $\pm$ 1 dB. This feature was not activated during the evaluation.

#### 4. GROUND STATION TROUBLES.

No catastrophic failures (failures which, after manual reset, prevented the station from performing its primary function of synchronizing a CAU or Mini-CAS) were noted. Virtually all failures were connected with the alarm system designed to detect station failures and switch essential functions to the unaffected channel.

During acceptance testing, two circuit boards (A5 and A10) in each channel had to be modified to correct an improper display of the slot number of the aircraft being monitored. (An additional display problem which occurred later during the flight tests was the display of unrealistic range rates by the channel 2 monitor. Because this display was not an essential functional part of the station, and was not even required under the terms of the contract,

testing was not interrupted to fix it.) Another modification prompted by acceptance testing was made to both A9 boards to prevent biphasic BIT failures caused by multipath.

Another problem during acceptance testing was a condition in which the automatic switchover failed. With channel 1 acting as master and channel 2 acting as slave, and both channels using the channel 1 digital clock as a reference, the clock delay on channel 1 was decreased by 1 ms, whereupon channel 1 momentarily switched to the slave function and then back to the master function. Channel 2 also switched to the master function, leaving both as masters. The three other permutations of initial conditions (channel 2 master, channel 1 slave, and internal/clock), also produced this abnormal reaction. When a failure was produced by increasing the delay, proper transfer of functions occurred. This automatic switchover condition was corrected by modifications to the A3 logic card. In referring to the "two masters" problem, caused by manually selecting master/slave auto mode simultaneously in both channels, this condition was not corrected and was not considered a serious fault. A timing problem of a slightly different nature occurred when video appeared at long range in the time slot (1,227  $\mu$ s to 1,235  $\mu$ s after slot time zero). This trouble manifested itself when (1) the altitude occurred 1,227  $\mu$ s to 1,235  $\mu$ s after verification of the range pulse (90 to 100 nmi), and as a result, failed the logic test, and (2) when the range pulse was received at 1,227  $\mu$ s to 1,235  $\mu$ s (200 nmi). The problem was corrected by modifications to the A6 card of each channel.

Not directly related to the experimental equipment was a timing problem caused by a defective beam tube in one of the cesium beam frequency standards used for station timing. It was replaced by the manufacturer under warranty.

An irregularity that was not corrected by the designer, was that the MOD INH lamp did not light when the modulation was manually inhibited. The lamp did light as required during the automatic modulation inhibit cycle that occurred upon station startup to protect the transmitter during warmup.

Another timing problem that was never corrected was that in bringing the station up from a totally unsynchronized start (i.e., an initial time difference of more than approximately 1 second between the two digital clocks), it was necessary to interrupt the 1-MHz line from one cesium standard or the other, and reconnect it so that both epoch pulses were within approximately 1 second of each other. They could then be synchronized to each other within a few nanoseconds by using the digital delay lines.

Later in the testing, the following logic problem turned up in the alarm system: when the channel 2 clock was more than 34 nanoseconds ahead of the channel 1 clock, the logic in channel 2 assumed the NO-GO state and would not restart until both were brought within a few nanoseconds of each other, or until the channel 2 clock was behind channel 1. This problem, which observed by the contractor's field engineer, cleared up the next day, before it could be corrected.

Approximately 2 weeks later, another problem occurred in which both channels assumed GO status on the basis of only one epoch pulse (from the channel 1 clock). This was an abnormality because the two-out-of-three requirement was not met.

Finally, toward the end of flight testing, a problem occurred which was apparently related to temperature. With channel 1 acting as master, a MASTER/SLAVE LOOP FAIL alarm came up on channel 1. When a restart was attempted on channel 1 (which normally would have reconfigured the station with channel 2 as master and channel 1 as slave), channel 2 had RECVR and LOW FWD POWER alarms and no measurable forward power as indicated by the panel meter.

Yet, when in the slave mode, channel 2 had radiated normally. Master control reverted to channel 1.

After approximately 40 minutes of station operation, the trouble cleared. The following morning, the same problem recurred, and cleared after 10 minutes of operation. This was the final day of flight testing and the contractor's field engineer had left, and no attempt was made to isolate the trouble.

The other items of an incidental nature were (1) the patch cords from the 5-MHz outputs of the cesium clocks to their respective 5-MHz resolvers were approximately 2 feet too short to permit sliding the clocks out along their support tracks for testing or servicing while still in operation, and (2) toward the end of the test period, there was an intermittent noise believed to originate in the channel 1 blower motor bearings.

The majority of the problems which occurred during the airborne evaluation were not repeatable on a daily basis, making it extremely difficult to troubleshoot.

It should be emphasized that these failures were judged to be of a fundamental nature, and the station reliably performed its primary functions. There will be some corrective action necessary in the area of the alarm system.

#### REFERENCES

1. FAA Contract DOT-FA73WA-3239 and Engineering Requirement FAA-ER-240-016.
2. Air Navigation/Traffic Control Division, ANTC Report No. 117, Revision Ten - May 12, 1971, corrected through March 24, 1972.
3. MDEC - Instruction Manual for Collision Avoidance Ground Station Developmental Model A03G0087-1.
4. MDEC - Instruction Manual for Collision Avoidance System Airborne Equipment - A12A0701.
5. Design of ACAS Instrumentation Display and Magnetic Tape Interface, Systems Equipment and Engineering Branch, ANA-140.
6. CAS Card/Mag Reduction BCD Computer Program for Project 052-241-000, prepared by Data Processing Branch, Engineering Application Section, ANA-553.
7. Air-to-Air Range/Bearing Program, Project 052-241-000, prepared by NAFEC, Data Processing Branch, ANA-553.
8. CAS Tape List Program - Project No. 052-241-000, prepared by NAFEC, Data Processing Branch, ANA-553.
9. Test Plan Project No. 052-241-010, Flight Test Outline for Evaluation of MDEC Collision Avoidance System, prepared for U.S. Department of Transportation, FAA SRDS, April 1975.
10. Technical Facilities Manual, Revised April 1965, NAFEC, Atlantic City, New Jersey.
11. Flight Test Evaluation of Secant Vecas Collision Avoidance System, Final Report NADC-74207-60.
12. Flight Test Evaluation of Avoid I Collision Avoidance System, Final Report NADC-75056-60.
13. Hahn, G. J. and Shapiro, S. S., Statistical Models in Engineering, John Wiley and Sons, Inc., New York, 1967, Pages 295 - 297.

APPENDIX A

ANA-140, ACAS T/F RESULTS OF FLIGHT ACCEPTANCE TEST, JANUARY 22, 1975

**DEPARTMENT OF TRANSPORTATION  
FEDERAL AVIATION ADMINISTRATION**

DATE: January 22, 1975  
REPLY TO: ANA-140  
SUBJECT: Subprogram Activity No. 052-241-010 -  
ACAS T/F, Results of Flight Acceptance Tests  
FROM: Project Engineer, ANA-140  
TO: Program Area Leader 05-111, ANA-140

NATIONAL AVIATION FACILITIES  
EXPERIMENTAL CENTER  
ATLANTIC CITY, NEW JERSEY 08405



INTRODUCTION

The final acceptance test of the Collision Avoidance System airborne equipment consisted of a series of five flights, starting on November 14, 1974, and concluding with the December 13, 1974, flight.

Each flight was greater than 2 hours duration following the suggested Field Test Plan outline.

The test setup utilized the Dual Channel Ground Station to provide air synchronization and monitoring of the test aircraft. In addition, a demonstration of the Fly-By Sync (FBS) technique was performed over the air-to-ground communication link.

The aircraft were configured as follows:

Aircraft No. 1 N-377

1. CAS Fly Rack - includes cesium beam clock, FBS panel and Collision Avoidance Unit (CAU).

2. Additional equipment rack contained the Mini Cas,  $\Delta R/\Delta t$  unit for CAU, McDonnell Douglas Electronics Corporation (MDEC) owned instrumentation photo panel, 16 mm data camera and time-of-day code generator.

Aircraft No. 2 N-376

1. Equipment rack contained CAU, Mini Cas,  $\Delta R/\Delta t$  unit for CAU, MDEC instrumentation photo panel, 16 mm data camera and time-of-day code generator.

Aircraft No. 1 was primarily used for test of the FBS equipment on two flights and then reverted to either a CAU or Mini Cas configuration.

Aircraft No. 2 was set up as the test dictated by connecting the instrumentation and antennas to their appropriate interfaces. For instance if the aircraft was configured for Mini Cas operation the CAU is normally "off" or in "standby" with radio frequency transmissions inhibited. The CAU and Mini Cas were not operated simultaneously in the same aircraft due to antenna separation which would have to be 50 feet or greater. In addition other means would have to be taken to prevent "zero range" threats from the operational equipment.

### OBJECTIVES

The primary objective of the flight program was to exercise the CAU and the Mini Cas in a flight environment to determine the following performance characteristics:

1. Display of appropriate reciprocal commands and advisories by both the CAU and Mini Cas Maneuver Indicators.
2. Correct instrumentation displays.
3. Maximum range to the ground station.
4. Maximum range at which CAU's start up and synchronize with the ground station.
5. Maximum range between two cooperative aircraft.
6. Back Up Mode (BUM) reciprocity.

### TEST PROCEDURES SUMMARY

The ground station was brought up in the Master/Slave (M/S) mode one hour before take off of the aircraft. After ground channels and airborne equipment were synchronized a ramp test was performed to verify equipment operation. Upon completion of the ramp test the epoch counters of the airborne instrumentation units were synchronized before take off. After take off the aircraft joined up at the test altitude to calibrate altimeters and check maneuver indicators for appropriate reciprocal commands and advisories. During the in-flight calibration and check the ground station operator was notified of the message slot number in each aircraft to allow him to monitor the entire flight on his displays.

3

The individual flight highlights and aircraft configuration are as follows:

Flight No. 1

Aircraft No. 1 - CAU

Aircraft No. 2 - CAU

The purposes of this flight were: to determine the maximum communication range to the ground station for the CAU; to determine the maximum range at which the CAU's start up and synchronize; to determine BUM operation when beyond maximum communication range.

Flight No. 2

Aircraft No. 1 - CAU

Aircraft No. 2 - CAU

This flight was a repeat of Flight No. 1 with the additional objective of determining air-air range performance between the two aircraft. Also a FBS start-up and sync calibration sequence was performed with the ground station.

Flight No. 3

Aircraft No. 1 - Mini Cas

Aircraft No. 2 - Mini Cas

The purposes of this flight were: to determine the Mini Cas maximum range performance with the ground station; to determine the start-up range to obtain synchronization; to determine the air-air range performance.

Flight No. 4

I

II

Aircraft No. 1 - Mini Cas - Mini Cas

Aircraft No. 2 - Mini Cas - CAU

This flight consisted of two parts. The purpose of Part I was to fly selected threat encounters between two Mini Cas equipped aircraft utilizing sync from the ground station.

The purpose of Part II was to fly selected threat encounters between a CAU equipped aircraft and a Mini Cas equipped aircraft with the CAU providing synch to the Mini Cas Unit.

#### Flight No. 4A

Aircraft No. 1 - CAU/FBS

Aircraft No. 2 - Mini Cas

This test utilized a CAU/FBS equipped aircraft as the main synchronization source during all flight encounters. The CAU maintained sync from its Cesium Beam clock, which has a demote rate of 41 minutes per hierarchy step in the absence of resync from a ground station. The ground station, inhibited throughout the test and was used only as a monitor.

#### Encounters Flown

##### No Alarm Tests (AR/At mode)

- a. Co-altitude, Range > R min.
- b. Off-Altitude, range < R min.

##### Low Altitude Threats

- a. Linear encounter (head-on, scissors and tail chase)
- b. Turning encounter (parallel and turn-in)
- c. Climb/Dive (vertical scissors)

#### RESULTS

The acceptance test on the CAU equipment indicated that a maximum range of 160 nautical miles (n. m.) @ 21,000 feet was attained for one radial leg from the ground station. The range at 8000 feet was 105 n. m. At this point, sync became sporadic and for all practical purposes this can be considered the lower altitude range. The radials selected for the flight paths provided a mixture of water and land over-flights.

The maximum range as monitored on the photo panel display was 96 n. m. which was limited by the on-board instrumentation, a limitation imposed by the factory design.

5

In the test involving CAU's regaining sync, values of 60 and 65 n. m. were recorded. This is less than the design value of 90 to 95 n. m. because the aircraft were in a threat situation until they reached a range of 70 n. m.

A communications range air-air between aircraft on diverging radials was 95 nautical miles. This range figure, as explained earlier, was limited by the instrumentation photo panel display. As recorded on the data log sheets FBS calibrations were performed with the CAS ground station. In each case the station initially acquired a coarse sync around 60 n. m. and proceeded to resync at 40 n. m. The time differences on the ground station TIME DIFF display as noted are within tolerances.

The test data on Mini Cas may be found in Figure 1 "Flight Test Data" and interpreted in the same fashion as CAU information. An equipment operating hour summary (Figure 2) for each aircraft is approximate since warm up and trouble shooting time was not taken into account.

The maneuver indicator operating in conjunction with both equipments functioned properly during all flights.

A limited review of available data reduced from Flight No. 4 indicates the threat and advisory logic is operational and ready for complete flight testing.

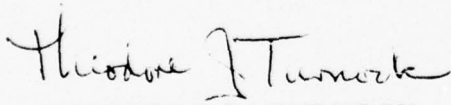
  
THEODORE J. TURNOCK

2 Enclosures

<u>CAU</u>	<u>Flt. No. 1</u>		<u>Flt. No. 2</u>		<u>Flt. No. 4</u>
<u>Max Range to CAS/GS-Air Display</u>	95	96.6	96.8	96.4	100
			91.3	94.8 @ 8K'	
<u>Max Range to CAS/GS-Ground Display</u> (Loss of A/C Data on Display)	160	161	122	161	
			105	105 @ 8K'	
<u>Range to CAS/GS when CAU's Sync</u>	59.6	64.8			
<u>Max Range Between Aircraft</u>			96.9	96.5	
			79.3	78.4	
<u>FBS Calibration of G/S Resync No.</u>			1. Acquired 62.4 n. m. in sync @ 40 1419.3 usec.		
			2. Acquired in sync @ 42 1419.3 usec.		
<u>Time Difference Display at GS</u>			1. CH #1. +0.015usec CH #2. + 0.0 usec.		
			2. CH #1. + 0.0 usec. CH #2 -0.025 usec.		
<u>Mini CAS</u>					
	<u>Flt. No. 3</u>		<u>Flt. No. 4</u>		
<u>Max Range to CAS/GS Air</u> (n. m.)	94.8	81	95		
	92.3	95			
<u>Max Range (n. m.) CAS/GS to A/C</u> (Ground Display)	91	93			
	92	91.7			
<u>Range (n. m.) to CAS/GS to Sync Mini CAS</u>	45.2	41.1			
	43.9	37.4			
<u>Max Range (n. m.) Between Aircraft</u>	55				
	39.9				

NOTES

- Instrumentation limitations of 97 n. m. aboard aircraft.
- Aircraft were joined until 70 n. m. point whereupon threat was broken.
- Aircraft were turned when 105 n. m. from Ground Station.
- Limited by turn around range was not extended.

All numerical data in nautical miles except where otherwise noted.

FIGURE 1. FLIGHT TEST DATA

<u>ITEM</u>	<u>FLIGHTS</u>	<u>OPERATING TIME</u> Hours
CAS/GS (Ground Station)	N/A	62
Aircraft No. 1 CAU/FBS Mini Cas	6	15.1
Aircraft No. 2 CAU Mini Cas	5	14.0

FIGURE 2. SUMMARY EQUIPMENT OPERATION

APPENDIX B

SUMMARY OF ACAS FLIGHTS

Type of Flight	CAU vs. CAU Flight No.	Mini-CAS vs. Mini-CAS Flight No.	CAU vs. Mini-CAS Flight No.	*CAU, CAU, 9 Mini-CAS * Flight No.
Single Daisy	8, 41, 46 27, 29, 30, 57	49, 50	15, 16, 9	31, 32, 33 36, 37, 38, 58
Double Daisy	20, 21, 23, 25, 26	19, 43, 44, 45, 48	10, 11, 12, 13, 14	
Theodolite EAIR Accuracy	6, 7, 25A	4, 5	1, 2, 3, 9, 17, 18	34, 35 39, 40 59, 60
Parallel Tau Zone	42, 47 61, 62	51		
Altitude Tau Zone Boundary	55, 63, 65	52, 53, 64		
Lateral Maneuver	55	54		
Climbing- Diving Maneuver	65	64	64	
Special Flight Tail-Chase BUM	7, 23, 65	54		

\* Three-Aircraft Flights

Flight Numbers.....17 and 18 TACAN Range Accuracy Flights.  
 .....22, 24, 28, and 56 Aborted in Flight: No data were collected.  
 .....63 and 64 Electromagnetic Compatibility Testing.

APPENDIX C

NOTES FROM LOG BOOK ON NAFEC SUPPORT - BY MDEC  
FROM MAY TO AUGUST 1975

JUNE 5.

No fly. Bad weather. Tried FAA instrument cable again on A/C 376. Can't operate both FAA instruments and MAC instruments at the same time. The problem is the 5-MHz that drive FAA instruments and MAC instruments and DR/dT box. Added pull up 1k resistor in both instruments and cut 5-MHz return at J7. This cleans up the 5-MHz, but is still marginal.

This Mini-CAS was S/N 1 and initially was used to interface with NAFEC instrumentation. Cable return was cut to enable operation of MAC and NAFEC instrumentation.

JUNE 9.

5 MHz clock from Mini-CAS was about 2-V at NAFEC instrumentation, so the 54LS04 IC driver was replaced with a 5404. 5-MHz increased to 4-V and better shape of waveform. NAFEC instrumentation worked some better, coming up occasionally with 1419.4 on resync.

Continuing interface tests with NAFEC and MDEC connected in parallel and separately. Mini-CAS driver was replaced and 5-MHz waveform level increased to normal range.

JUNE 11.

Double Daisy Flight No. 19, A/C 1, Mini-CAS 1 vs. A/C 2 Mini-CAS 2.

Range verification of variations on Mini-CAS 1 as compared to Mini-CAS 2.

JUNE 12.

Continuing with Mini-CAS interface with NAFEC instrumentation during the day---- Mini-CAS failed to sync at 4:00 P.M. Trouble traced to no message slot. CMOS chip F4D on the A5 card was bad. NAFEC had a replacement CD4023 which cured the problems.

Mini-CAS 1 now has two oddball IC's. The 4023 was a Motorola MM 14023?? and I am not sure the temperature range is the same as the CD4023AT that was in there.

JUNE 13.

A4 which on June 9 was replaced with a 5404 was changed back to 54LS04. Added ground wire from pin C on J7A.... 7440 used to drive 5 MHz ... MDEC and

NAFEC instrumentation appears to work on the long lines. Mini-CAS provides a good clock although the signal level in the interface still has problems.

From June 12 thru June 24, Mini-CAS 1 remained at Bldg. 156, being used for interfacing with NAFEC instrumentation.

JUNE 27.

Measured transmitter power and receiver sensitivity of both Mini-CAS's. Both OK. Showed NAFEC personnel how to set-up and make Mini-CAS measurements. (Mini-CAS 1 power and receiver sensitivity appeared normal at this time).

JUNE 26, 1975.

Measured transmitter power and receiver sensitivity on CAU 1 and CAU 2. Both OK. (See measurements in table 1-1 and table 1-2).

CAU 1 antenna was in upper position from start of test period.

Flights where CAU 1 was used are:

Theodolite	6,	3-6	
Runs	7,	4-1	
	8,	4-11	
D.D.	(21	6-18	4 runs aborted
CAU vs.	22	6-19)	TACAN problem 1 run aborted
CAU			

JUNE 27, 1975.

CAU 1 won't sync- suspect bad exciter because transmitter has no power output and receiver doesn't "see" G/S transmission. Disconnecting first LO output from exciter has no effect on receiver noise. It should. Replaced exciter with spare exciter 3 (original exciter delivered with CAU in October, 1975, repaired in February, 1975.) CAU 2 now OK.

JULY 18, 1975.

Checked out Mini-CAS 1 on N376 with MDEC instrumentation NO XMIT ALT PULSE - Removed to G/S lab, Bldg. 156. Isolated problem to A<sub>3</sub> board. Verified by substituting A<sub>3</sub> card from Mini-CAS 2. Problem solved. A3-C8 (5496 IC) bad.

JULY 19, 1975.

Three A/C flights using Mini-CAS 1 in A/C 2 (N376).

JULY 21, 1975.

Checked Mini-CAS 1 OK.

JULY 22, 1975.

Checked Mini-CAS 1 OK.

JULY 23, 1975.

Checked Mini-CAS 1 OK.

July 24, 1975.

Checked Mini-CAS 1 OK.

JULY 28, 1975.

Looked at N376 Mini-CAS is MDEC instrumentation for possible problem with Bogey-Select readout. All OK during 1-hour test.

JULY 31, 1975.

Afternoon studied Mini-CAS altitude (XMIT) logic.

AUGUST 1, 1975.

Fixed Mini-CAS 1 altitude logic. Reference July 18 problem: Bad IC (A3-C8-5496) replaced with type 7496--5496 not available-work OK now on bench.

AUGUST 14, 1975.

Flight 43 - Range contact lower on N376 than N377.

AUGUST 15, 1975.

Flight 44 - At ramp to check out Mini-CAS's on N377 and N376. Both have trouble getting two consecutive epoch starts. OK after sync is achieved.

APPENDIX D

MDEC LETTER, COMPLETION OF FACTORY ACCEPTANCE TEST  
WITH A LIST OF FAILURE REPORTS REQUIRING REVIEW  
AND WAIVER APPROVAL BY CONTRACTING OFFICIAL,  
OCTOBER 9, 1974

9 October 1974  
1163-DJH-36233

Department of Transportation  
Federal Aviation Administration  
800 Independence Avenue, S.W.  
Washington, D.C. 20591

Attention: Mr. E. M. Klink - ALG-362  
Contracting Officer

Subject: Contract DOT-FA73WA-3239

Attachments: (1) Failure Report No. 05420  
(2) Failure Report No. 05423  
(3) Failure Report No. 05425  
(4) Failure Report No. 05426  
(5) Failure Report No. 05428  
(6) Failure Report No. 05429

Dear Sir:

The Factory Acceptance Test for the equipment provided under the subject contract has been satisfactorily completed. Failure reports were written on all discrepancies noted during the Acceptance Tests where limits specified in the approved Factory Test Procedure were not met by the equipment. With the exception of three basic discrepancies all failure reports noted during the Factory Acceptance Tests were resolved, and correct operation verified by McDonnell Douglas Electronics Company Quality Control and the FAA Quality Reliability Officer.

McDonnell Douglas Electronics Company is asking for waivers on the three discrepancies not resolved inasmuch as the conditions noted are caused by inconsistencies within ANTC-117 or tolerances imposed by ANTC-117 on the Factory Acceptance Test Procedure. None of the discrepant conditions noted will adversely affect the functions of the equipment or flight safety, nor will it adversely restrict in any way the full capability of the equipment.

The three discrepant conditions associated with the attached Failure Reports are summarized below:

A DIVISION OF

**MCDONNELL DOUGLAS**  
D-1 CORPORATION

Item 1 Failure Report 05420 and Failure Report 05423

After applying power to a cold Collision Avoidance Unit (CAU), the Collision Avoidance Unit will start operation in back-up mode (BUM) before an oscillator accuracy of  $1 \times 10^{-8}$  is achieved.

Item 2 Failure Report 05425 - Failure Report 05428 and Failure Report 05429

Steady state TAU 1 threats at the boundaries between altitude bands sometimes shift from one band to the other momentarily, always in the direction to provide an early alert of a potential threat.

Item 3 Failure Report 05426

On one of the two Collision Avoidance Units (CAU) the first to third pulse spacing of the resync triad is out of tolerance by 20 nanoseconds.

There is no specification in ANTC-117 or ER 240-016 for time-out prior to start of operation in the back-up mode (BUM). Both Collision Avoidance Units do not achieve the required oscillator accuracies within the time specified in the Factory Acceptance Test Procedure. However, on each unit (within one minute of specification) the oscillator achieves an order of magnitude better accuracy than is required by specification. Since warm up time is not specified and considered a market place item, McDonnell Douglas Electronics Company recommends acceptance of the Collision Avoidance Unit as is since the temporary inaccuracy will have no affect on system operation.

The second basic discrepancy is related to the mechanization of the altitude threat logic in both the Collision Avoidance Unit and Mini-CAS. Altitude input to the CAS is in a special gray code format with the least significant bit equal to 100 ft. Altitude is pulse position encoded for transmission at a rate of 0.4 usec per 100 feet input increment with reference to the leading edge of the range signal. Upon reception, the altitude is decoded with reference to the range pulse in the same manner as encoded for transmission.

If the 5 MHz oscillator in the transmitting system is exactly in phase with the oscillator in the receiving system, the Altitude encoded in one system will be perfectly decoded in the other system. However, as the phase of one oscillator shifts with respect to the other the decoded altitude can vary by one least significant bit in the decoder which results in a change of 100 feet in the decoded altitude. Therefore, the only way ANTC-117 requirements incorporated in the Factory Test Procedure can be achieved is if the oscillator of the participating units remain perfectly in phase, which is impossible. McDonnell Douglas Electronics Company therefore allowed for the shift of 100 feet from one band to the next at the altitude band boundary limits such that they only occur at the extreme of the phase differences, and the majority of the threats were correctly detected in the altitude band occupied by the TAU 1 threats. Due to the inconsistency in ANTC-117 McDonnell Douglas Electronics Company has assured that threats will be detected at the earliest point in time. On this basis MDEC requests waiver of failure reports written on this discrepant condition and acceptance of the units "as is".

During the Factory Acceptance Test of one of the two Collision Avoidance Units provided under the subject contract, a measurement of the RF signal at the antenna revealed that the time between the first and third pulses of the resync triad pulse trains was 20 nanoseconds greater than the tolerance (50 nanoseconds) specified in ANTC-117 and the Factory Acceptance Test Procedure. Considering this very tight tolerance on the signal in space and the major retuning and rework that would have been required, McDonnell Douglas Electronics Company requests waiver of the Failure Report covering this discrepancy inasmuch as the system operation is not affected in any way and the correction of this discrepant condition would not improve operation of the Collision Avoidance Unit.

Page 4  
1163-DJH-36233

These discrepant conditions have been coordinated and discussed with Mr. Owen McIntire, the Technical Officer and Mr. Jack Brennan. It is requested that you review these conditions with them and provide the requested approvals for waiver.

Very truly yours,

MCDONNELL DOUGLAS ELECTRONICS COMPANY

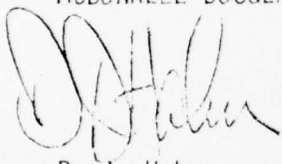
A handwritten signature in cursive script, appearing to read "D. J. Hahn".

D. J. Hahn  
Senior Contract Coordinator  
Commercial Contracts Administration

APPENDIX E

ARD-242 LETTER, DECISION TO TEST MDEC CAS IN IDENTICAL FASHION AS  
RCA AND HONEYWELL CAS, NOVEMBER 13, 1974

13 NOV 1974  
DEPARTMENT OF TRANSPORTATION  
FEDERAL AVIATION ADMINISTRATION

DATE: 13 NOV

WASHINGTON, D.C. 20591

IN REPLY  
TO: ARD-242



SUBJECT: Test and Evaluation of McDonnell Douglas T/F ACAS Equipment

FROM: Chief, Detection Systems Branch, ARD-240

TO: Chief, Systems & Equipment Engineering Branch, ANA-140

As you are aware, the AED-2 decision that the above referenced equipment be tested in as near identical fashion as the RCA and Honeywell ACAS Equipment resulted in the requirement for a modification to the McDonnell Douglas contract.

This contract modification is now nearing finalization; however, financial considerations have limited its extent. As a result, it will be necessary for NAFEC Personnel to accomplish the following:

1. Remote the MINI-CAS Indicators into the cockpit of the test aircraft.
2. Fabricate the required mounting pallets and wiring harness required to allow a three aircraft encounter to be flown. The third aircraft need not be capable of handling the fly-by-synch.

Enclosed is descriptive material supplied by McDonnell-Douglas in response to our RFP, relative to the above. This matter has been discussed with Messrs. Iasewicz and Scozzafava and has their concurrence. Should problems arise at any time or should this result in your need for additional dollars, please inform us as soon as possible.

*for* *Kevin E. M. [unclear]*  
KENNETH WISE

Enclosure

*Kevin E. Scozzafava for action*

*12 Dec 74*

*278*

identical to those being loaned to the Government. A camera will not be provided. Since commercial practices were utilized in the manufacture of the units being loaned to the Government, construction of this unit will be identical. The photo panel will become the property of the Government.

Item 5. Mounting Pallets and Wiring Harnesses - The contractor will fabricate and deliver, five months from receipt of order, one mounting rack for a CAU and one mounting pallet for a Mini-CAS,  $\Delta R/\Delta T$  unit and instrumentation package, plus the necessary wiring harness to operate either a CAU or Mini-CAS on the third airplane. In operation, either a CAU or a Mini CAS will be moved from one of the other two airplanes and installed on the mounting racks in the third airplane. The harness and mounting provisions for the third airplane will not be capable of handling the FBS rack with the cesium beam frequency standard and clock. Two CAS blade antennas will be included on loan to the Government.

Item 6. Remote Mini-CAS Indicator - Two test engineer Mini-CAS indicators will be fabricated and delivered to the Government five months after receipt of order together with harness provisions to move the indicator normally mounted in the Mini CAS to the pilot's instrument panel. The Test Engineer's indicator will have one light for each command/status, a power switch and a lamp test switch. The lamps will be mounted on a Bud aluminum box approximately 4" x 6" x 3".

ITEM NO: 5 DESCRIPTION HARNES & MTG. PALLETS

<u>PART NUMBER</u>	<u>NOMENCLATURE</u>	<u>QUANTITY</u>	<u>UNIT COST</u>	<u>TOTAL COST</u>	<u>DATA SOURCE</u>
-	RAK, 1 ATR	1 SET	\$ 241.27	\$ 241.27	PO WLS448
DPX2MA-C8AP-106S-33B-0000	CONNECTOR	1	137.16	137.16	HISTORY
DPX2MA-D32C2S-F40C1S-33B-0012	CONNECTOR	1	63.49	63.49	HISTORY
M83723-13RI418N	CONNECTOR	1	30.59	30.59	HISTORY
M83723-13R2255N	CONNECTOR	2	46.18	92.36	HISTORY
F M83723-14RI432N	CONNECTOR	2	26.96	53.92	HISTORY
M83723-16-22C	COVER	1	5.00	5.00	ESTIMATE
M827467115P35P	CONNECTOR	1	33.15	33.15	HISTORY
M827467115P35S	CONNECTOR	1	56.70	56.70	HISTORY
DPX2MA-C2S-F40C1S-33B-0013	CONNECTOR	1	130.68	130.68	HISTORY
UC628A	CONNECTOR	1	3.80	3.80	CAT - CR
UC1185B	CONNECTOR	5	2.54	12.70	CAT - CR
UC29A	ADAPTER	1	2.45	2.45	CAT - CR
<u>TOTAL:</u>				<u>\$ 863.27</u>	

APPENDIX F

ANA-140, EVALUATION OF ACAS TAU  
WARNING ACCURACY RESULTS, DECEMBER 15, 1975

**DEPARTMENT OF TRANSPORTATION  
FEDERAL AVIATION ADMINISTRATION**

DATE: December 15, 1975

NATIONAL AVIATION FACILITIES  
EXPERIMENTAL CENTER  
ATLANTIC CITY, NEW JERSEY 08405

REPLY TO: ANA-140



SUBJECT: Evaluation of ACAS tau warning accuracy results

FROM: Analysis Director, ACAS, ANA-140

TO: Program Area Agreement Manager, ANA-140

The results of the McDonnell-Douglas airborne collision avoidance system (ACAS) tau warning accuracy analysis were discussed at a meeting at NAFEC on December 10, 1975, with Mr. J. Brennan, ARD-212. The data was qualified by sample size and types of maneuvers flown. In addition, it was mentioned that the data presented was not influenced by communications reliability failures. Since communications reliability is generally above 90%, the data would not vary significantly even if such failures were included.

In the case of the tau 2 warning data, it was emphasized that for the Mini and the Cau, the initial warning lights are expected to go on about 1.5 seconds on the average following transition into the tau 2 zone due to slot phasing between two aircraft. The results of our tests show this to be true.

In the case of the tau 1 warning data, the Mini should again provide a light around 1.5 seconds on the average following transition into the tau 1 zone. The Cau, however, incorporates a "two out of three" logic to reduce the probability of an early alarm. This means that on the average, the Cau should alarm around 4.5 seconds following transition into the tau 1 zone. This special logic was provided to compensate for the relatively high variation in the "doppler-derived" range rate. Since the Cau currently derives its range rate from the  $\Delta r / \Delta t$  unit, this logic could be deleted as in the case of the Mini. Again the results of the tests indicate that the Cau and the Mini performed as expected.

Finally, it was agreed at the meeting that since the tau 2 and tau 1 zone boundary lines specified in ANTC 117 pertain to static test condition the flight test data indicates that the Cau very closely met the specification for both lines. The Mini also shows compliance to the tau 2 line but instead of the tau 1 line passing through a range equal to .25 nmi, it seems to pass through zero range. McDonnell-Douglas indicated that they designed it this way because it was using the  $\Delta r / \Delta t$  unit

2

instead of the doppler range input. This seems quite acceptable since the .25 nmi offset was put into ANTC 117 to compensate for the doppler range rate bias of approximately 30 knots.

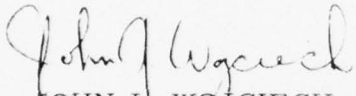
  
JOHN J. WOJCIECH

cc:  
ARD-212 (J. Brennan)  
McDonnell-Douglas (K. Toerper)