

AD-A037 447

GOLDSWORTHY ENGINEERING INC TORRANCE CALIF
U.S. ARMY AUTOMATED TAPE LAYUP SYSTEM 'ATLAS'.(U)
DEC 74 D S STEWART

F/6 13/8

UNCLASSIFIED

DRSAV-76-37

DAAJ01-72-C-0610
NL

1 OF 4

AD
A037447



ADA037447



AD

AVSCOM REPORT NO. DRS AV-76-37
PRODUCTION ENGINEERING MEASURES PROGRAM
MANUFACTURING METHODS AND TECHNOLOGY

US ARMY AUTOMATED TAPE LAYUP SYSTEM "ATLAS"

David Shaw Stewart
Coldsworthy Engineering, Inc. ✓
23930 Madison Street
Torrance, CA 90505

1 December 1974

Final Report

Approved for public release: distribution unlimited

D D C
RECEIVED
MAR 28 1977
A

Prepared for

DEPARTMENT OF THE ARMY
U.S. ARMY AVIATION SYSTEMS COMMAND
ST. LOUIS, MISSOURI 63166.

AD NO. _____
DDC FILE COPY.

The findings in this report are not to be construed as an official Department of the Army position, unless so designated by other authorized documents.

Mention of any trade names or manufacturers in this report shall not be construed as advertising nor as an official indorsement or approval of such products or companies by the United States Government.

DISPOSITION INSTRUCTIONS

Destroy this report when it is no longer needed.
Do not return to the originator.

UNCLASSIFIED

SECURITY CLASSIFICATION OF THIS PAGE (When Data Entered)

REPORT DOCUMENTATION PAGE		READ INSTRUCTIONS BEFORE COMPLETING FORM
1. REPORT NUMBER AVSCOM Report No. DRSAV 76-37	2. GOVT ACCESSION NO. -	3. RECIPIENT'S CATALOG NUMBER -
4. TITLE (and Subtitle) U.S. ARMY AUTOMATED TAPE LAYUP SYSTEM "ATLAS"		5. TYPE OF REPORT & PERIOD COVERED Final Report 1 December 1974
7. AUTHOR(s) David Shaw/Stewart		6. PERFORMING ORG. REPORT NUMBER
8. PERFORMING ORGANIZATION NAME AND ADDRESS Goldsworthy Engineering, Inc. 2917 Lomita Blvd. Torrance, CA 90505.		9. CONTRACT OR GRANT NUMBER(s) DAAJ01-72-C-0610 (PIG)
11. CONTROLLING OFFICE NAME AND ADDRESS Department of the Army U.S. Army Aviation Systems Command St. Louis, Missouri 63166.		10. PROGRAM ELEMENT, PROJECT, TASK AREA & WORK UNIT NUMBERS PEM. Project 1716050
14. MONITORING AGENCY NAME & ADDRESS (if different from Controlling Office)		12. REPORT DATE 11 December 1974
		13. NUMBER OF PAGES 295
		15. SECURITY CLASS. (of this report) UNCLASSIFIED
16. DISTRIBUTION STATEMENT (of this Report) Unlimited		18a. DECLASSIFICATION/DOWNGRADING SCHEDULE
17. DISTRIBUTION STATEMENT (of the abstract entered in Block 20, if different from Report)		
18. SUPPLEMENTARY NOTES		
19. KEY WORDS (Continue on reverse side if necessary and identify by block number) Tape Layup Machine Multi-axis Numerically Controlled. Pre-impregnated Tape Advanced Composites		
20. ABSTRACT (Continue on reverse side if necessary and identify by block number) The objective of this contract was the design, manufacture, installation, and testing of the "ATLAS", an acronym for Automatic Tape Layup System. This final report provides detailed descriptions of: the machine system and components, the machine fabrication procedure, fabrication-site testing at Goldsworthy Engineering Inc., and installation and testing at the final site, The Boeing Company, Vertol Division.		

TABLE OF CONTENTS

		<u>PAGE</u>
SECTION I	INTRODUCTION	7
SECTION II	SUMMARY	10
SECTION III	MACHINE DESCRIPTION	13
3-1	General Description	14
3-2	Design Specifications	17
3-3	Base Sections and Ways	18
3-4	Gantry Unit	21
3-5	"Y", "Z" and "A" Axis Motions	26
3-6	Tape Placement Head	33
3-7	Headstock and Tailstock Units	57
3-8	Steady Rests	67
3-9	Controls	71
SECTION IV	MACHINE FABRICATION	97
4-1	Base Sections	99
4-2	Composite Gantry	101
4-3	Composite Cross Beam	112
4-4	Tape Placement Head	114
4-5	Digitizing Line Follower	122
4-6	Steady Rests	135
4-7	Machine Assembly	136
4-8	Control Integration	146
4-9	Tests and Demonstrations	155
4-10	Shipping	161
SECTION V	INSTALLATION OF ATLAS AT BOEING VERTOL	163
5-1	Installation	164
5-2	Alignment and Repeatability Checks	167
5-3	Tape Placement Developments	181
5-4	ATLAS Demonstration	197
5-5	Programming	201
5-6	Acceptance Tests	232

ACCESSION for	
DTIC	White Matter <input checked="" type="checkbox"/>
DOC	Diff. Index <input type="checkbox"/>
SEARCHED	<input type="checkbox"/>
INDEXED	<input type="checkbox"/>
<small>THIS INFORMATION IS UNCLASSIFIED</small> <small>DATE 10/15/01 BY 1043/UC/STP</small>	
A	

TABLE OF CONTENTS (CONT.)

		<u>PAGE</u>
APPENDIX I	TECHNICAL SPECIFICATIONS FOR A NUMERICALLY CONTROLLED TAPE LAYUP MACHINE FOR MONOFILAMENT FIBER STRUCTURES	242
APPENDIX II	TEST REPORT - EVALUATION OF PNEUMATIC PLACEMENT ROLLER CONTOUR COMPLIANCE CHARACTERISTICS	253
APPENDIX III	PERFORMANCE TEST PLAN - U.S. ARMY AUTOMATED TAPE LAYUP SYSTEM	268
APPENDIX IV	COORDINATED TEST PLAN - U.S. ARMY AUTOMATED TAPE LAYUP SYSTEM	277

LIST OF ILLUSTRATIONS

<u>FIGURE</u>	<u>DESCRIPTION</u>	<u>PAGE</u>
1	Numerically Controlled Tape Layup Machine	15
2	Location of Ways and Tooling Guides	19
3	Gantry Mounted on the Carriage Assembly	23
4	X Axis Drive	25
5	X,Y,Z and A Axis Drives	27
6	Y Drive Axis - Gantry Support Side	30
7	A Axis Drive	32
8	The Tape Placement Head	34
9	The C Axis Drive Motor	35
10	A Axis Carriage Assembly	36
11	The Payoff Reel and Load Sensor	38
12	The Paper Takeup Reel	40
13	The Shear	41
14	The Heater and Shear	43
15	The Slitting Assembly	45
16	The Slitting Assembly - Top View	46
17	The Tape Placement Roller	48
18	The Tensiometer	50
19	Tape Head Control Panel	51
20	Tape Head Auxiliary Control Panel	54
21	Tape Head Pneumatic Control Panel	56
22	Headstock	58
23	Vertical Ways, Headstock	59
24	Headstock Assembly, Rear View, Cover Removed	61
25	Tailstock	62
26	Vertical Ways, Tailstock	63
27	Tailstock Assembly, Rear View, Cover Removed	64
28	Quill Drive, Tailstock	65
29	Tailstock Air Cushion Controls	66
30	Spar Tooling and Steady Rest Arrangement	68

LIST OF ILLUSTRATIONS

<u>FIGURE</u>	<u>DESCRIPTION</u>	<u>PAGE</u>
31	Steady Rest Assembly	70
32	Numerical Control Console	73
33	Inside of the Control	74
34	Main Control Panel	76
35	Annunciators	79
36	Secondary Control Panel	80
37	Machine Tool Panel	88
38	Tape Reader/Spooler Panel	90
39	Digitizer Panel	91
40	Steady Rest Control Panel	93
41	Motor Control Center Panel	95
42	Motor Control Center	96
43	Base Section Castings	100
44	1/8 Scale Gantry Model	102
45	Gantry Model Rear View	103
46	Wooden Gantry Mock-up	104
47	Construction of Gantry Mock-up	105
48	Gantry Mould Sections	107
49	Gantry Mould Sections	108
50	Gantry Mould Sections	109
51	Typical Section Through Composite Gantry	110
52	Part Section of Cross Beam	113
53	Main Supporting Ring	115
54	Main Tape Head Frame	116
55	Shear Rotary Drive System	119
56	Tape Head Components	121
57	Reference Tape	125
58	Line Sensing Units	126
59	Line Follower Motions	128
60	Line Follower Assembly	130
61	Line Follower Mounted Under Tape Head	131
62	Remote Digitizer Panel	132

LIST OF ILLUSTRATIONS

<u>FIGURE</u>	<u>DESCRIPTION</u>	<u>PAGE</u>
63	Alignment Carriage	137
64	Alignment Carriage on Flat Ways	138
65	Z Axis - Gantry Drive Side	140
66	Z Axis - Gantry Support Side	141
67	X Axis Cable Track	143
68	Y Axis Cable Track	144
69	Acceleration Curves	149
70	X Axis Acceleration Velocity Traces	151
71	Digitizing Slope Deviation	154
72	Typical X, Y Axes Pen Trace Test	156
73	Root End Mock-up	159
74	X & Y Axes Alignment	172
75	Non-Rotating Placement Units	191
76	Flexible Foot Placement Unit	195
77	Flexible Foot Placement Unit	196
78	Digitized Points for Cross-Ply Wrap	225
79	Torsion Wrap Programming	230
80	Performance Test Plan Flat Layup	233
81	Performance Test Plan Flat Layup	234
82	Effect of Tape Width Tolerance	239
83	Slit Tape on Root End Mock-up	240
84	Pneumatic Placement Roller Test Fixture	257
85	Test No. 1 Contact Patch	258
86	Test No. 2 Contact Patch	259
87	Test No. 3 Contact Patch	260
88	Test No. 4 Contact Patch	261
89	Test No. 5 Contact Patch	262
90	Test No. 6 Contact Patch	263
91	Test No. 7 Contact Patch	264
92	Test No. 8 Contact Patch	265
93	Side View of Roller During Maximum Compression	266
94	End View of Roller During Maximum Compression	267
95	Flat Pattern Layout	275
96	45° Blade Pattern	276

LIST OF TABLES

<u>TABLE</u>	<u>DESCRIPTION</u>	<u>PAGE</u>
1	Program Plan	12
2	ATLAS General Specifications	16
3	Annunciators	78
4	Shipping Configuration for Component Subassemblies	162
5	X Axis Alignment	168
6	Y Axis Alignment	170
7	Y to X Axis Squareness	173
8	Z Axis Squareness to X and Y Axes	175
9	X Axis Repeatability	177
10	Y Axis Repeatability	180
11	Placement Roller Run-out	183
12	Placement Roller Run-out	184
13	Effect of Compaction Load on Roller Placement Accuracy	188
14	Letter A Program Printout	198
15	Printout of Leading Edge Wrap Program	227
16	ATLAS Repeatability Checks - Two Ply on Flat Pattern Layup	236
17	Repeatability Checks - Two Ply on Flat Pattern Layup	237

SECTION I

INTRODUCTION

SECTION I

INTRODUCTION

Immediately following Boeing-Vertol's confirmation that rotor blades made from advanced composites as their primary materials of construction were demonstrably more efficient than counterpart blades made from conventional metals, it became apparent that a method was needed whereby these blades could be manufactured on a production machine. Since those initial prototype and test blades had been fabricated by hand, a theoretically correct orientation and geometric arrangement of each lamella layer had, thereby, been reasonably well established. It remained only to develop a workable concept for an automated machine to reproduce, exactly, that pattern, or any similar planar orientation needed to fabricate structures from these materials. In particular, helicopter rotor blades/spars and other aircraft structures having configurations incorporating surfaces of compound curvature.

Based on first-hand experience in having laid up rotor blades from advanced composites, Boeing-Vertol was able to translate the multiplicity of movements needed to place composite tapes in their respective position and bi-axial orientation into the schematic representation of an automated production machine capable of reproducing essentially the same basic movements.

During the design phase immediately preceding this machine-building phase, Boeing-Vertol's concepts and performance specifications were transposed by this Contractor into detailed drawings of the complete production machine. Certain of the initial parameters were subsequently modified in order to present a more complete all-around capability.

The objective of this program was to fabricate the Automated Tape Layup System (ATLAS) machine. The program would be successfully accomplished when the ATLAS machine, installed at the Boeing-Vertol facility, had shown its ability to layup 3 inch wide glass epoxy tapes on flat and compound curved surfaces to a required degree of repeatability and reliability.

Successful demonstration of ATLAS at the Boeing-Vertol facility showed the versatility of the machine. Final acceptance tests showed the machine to fully meet its required performance within the limitations imposed by available composite tape specifications and tape placement unit developments.

SECTION II

SUMMARY

SECTION II

SUMMARY

This final report presents information on the complete fabrication and testing of the ATLAS machine.

The program was planned in two phases. Table 1 shows the program of these two phases.

The first phase was the complete fabrication, assembly and test of the machine at the Contractor's facility, Goldsworthy Engineering, Inc., Torrance, California. The phase ended with the disassembly and shipment of the machine to the Boeing-Vertol Company facility.

The second phase was the installation, test and demonstration of the ATLAS machine, at the Boeing-Vertol Company facility in Philadelphia, Pa.

Development work on the tape dispensing head placement system was a significant part of the second phase. The ATLAS machine was successfully demonstrated as a complete, reliable system, meeting the requirements of the Contract.

Further development work will continue to improve the placement units versatility in order to utilize the full potential of the ATLAS machine.

SECTION III

MACHINE DESCRIPTION

SECTION III

MACHINE DESCRIPTION

3-1 GENERAL DESCRIPTION

The Automated Tape Layup System (ATLAS) is a completely integrated six axis numerically controlled Tape Placement Machine.

The basic units of the machine are shown in Figure 1 and are as follows:

3-1.1 Cast iron modular base sections with aluminum tooling plate work surface.

3-1.2 Moving gantry ("X" axis) unit with vertical ("Z" axis), transverse ("Y" axis) motions on it.

3-1.3 Tape dispensing head, with rotary motion ("C" axis), mounted to the ("A" axis) tilting carriage.

3-1.4 Powered rotary headstock ("D" axis) and opposing tailstock unit.

3-1.5 Two steady rest units synchronized rotationally to the headstock ("D" axis) and linearly to the gantry motion ("X" axis).

3-1.6 Numerical control system with associated teletypewriter and tape punch, used for self-programming.

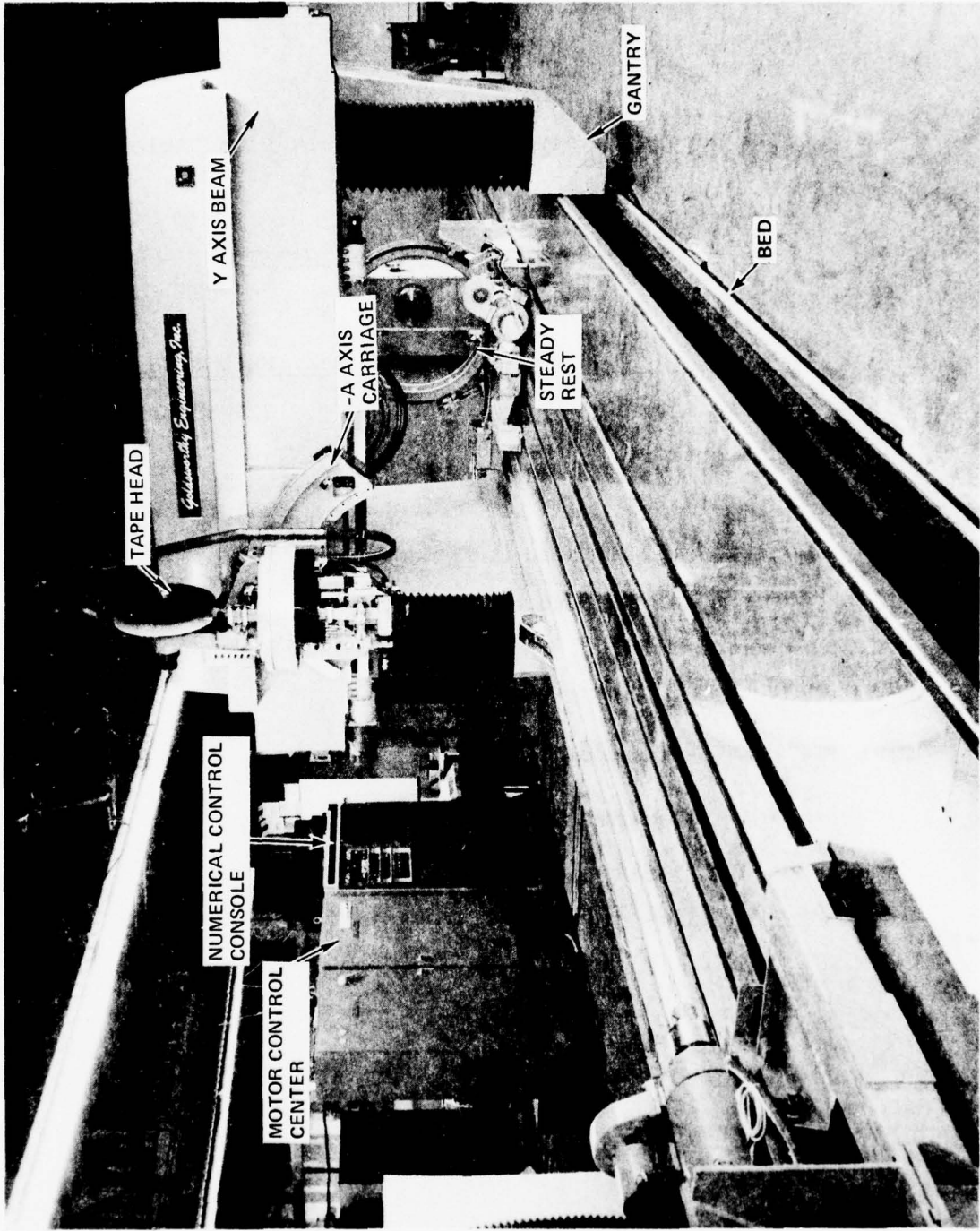

Figure 1. Numerically Controlled Tape Layout Machine

- 3-1 General Description (cont.)
- 3-1.7 Motor control center.
- 3-1.8 The general specifications are given in Table 2.

Table 2. ATLAS General Specifications

AXIS	MOTION	MOVEMENT (MAX.)	FEED RATE (MAX.)
X	Longitudinal	432 inches	720 inches/minute
Y	Transverse	96 inches	720 inches/minute
Z	Vertical	36 inches	150 inches/minute
C	Rotation of Tapehead	405 degrees	10 RPM
D	Rotation of Headstock	Infinite	10 RPM
A	Tapehead Tilt	+45 degrees	3 RPM

MAXIMUM OUTLINE DIMENSIONS

Length	672 inches (56 feet)
Width	204 inches (17 feet)
Height	132 inches (11 feet)

3-2 DESIGN SPECIFICATIONS

The design of the ATLAS machine, was done by Goldsworthy Engineering, Inc. under a preceding Contract.

3-2.1 Technical Specification which was the basis for the design was prepared by the Boeing Company, Vertol Division in their document EES-7-376, which appears in Appendix I of this report.

3-2.2 Design of the machine follows the Specifications closely, with a few deviations.

3-2.3 A certain amount of re-design was done during this Contract, in particular:

3-2.3.1 Base castings modified to allow for steady rest ways and driving gear rack.

3-2.3.2 A number of sub-assemblies in the Tape Head unit were modified. A decision was made to use 3 inch net width composite tapes, eliminating the original requirement to be able to use the 3 inch wide tapes on 4 inch wide paper backing.

3-2.3.3 Complete development of the Line Follower unit required basic design and detailing.

3-2.4 Design of the Steady Rest units was done from Specifications received from Boeing Vertol, during the Fabrication Phase of the Contract.

3-3 BASE SECTIONS AND WAYS

Design considerations had been given to the possibility of using a minimum of structure for the work table of the machine, by mounting the way rails and table top to a rigid foundation. However, since the machine was to be fabricated and tested at the Contractor's facility, then shipped to the Boeing Vertol facility, construction of two special foundations were not feasible.

The base sections were therefore designed as self supporting units with enough height to give good rigidity and heavy enough to stand in a free state without the need for hold down bolts.

Figure 2 shows the general layout of the base sections at the headstock end of the machine. Location of the gantry support ways, and driving gear rack, as well as the steady rest ways are shown.

3-3.1 Base Castings

To achieve the 36 ft. of gantry travel the base of the machine is 56 feet long, and consists of four pairs of castings, each 14 feet long and weighing 8,700 lbs.

The castings are of open construction, with the table surface being formed by 1 inch thick aluminum tooling plate.

3-3.2 The 1 inch thick aluminum tooling plate work surface provides the ability to drill and tap holes, for workpiece location. Damaged sections are easily replaceable.

3-3.3 Two continuous tee slots, located either side of the center reference slot, provide means of clamping the fixed headstock and the re-positionable tailstock units.

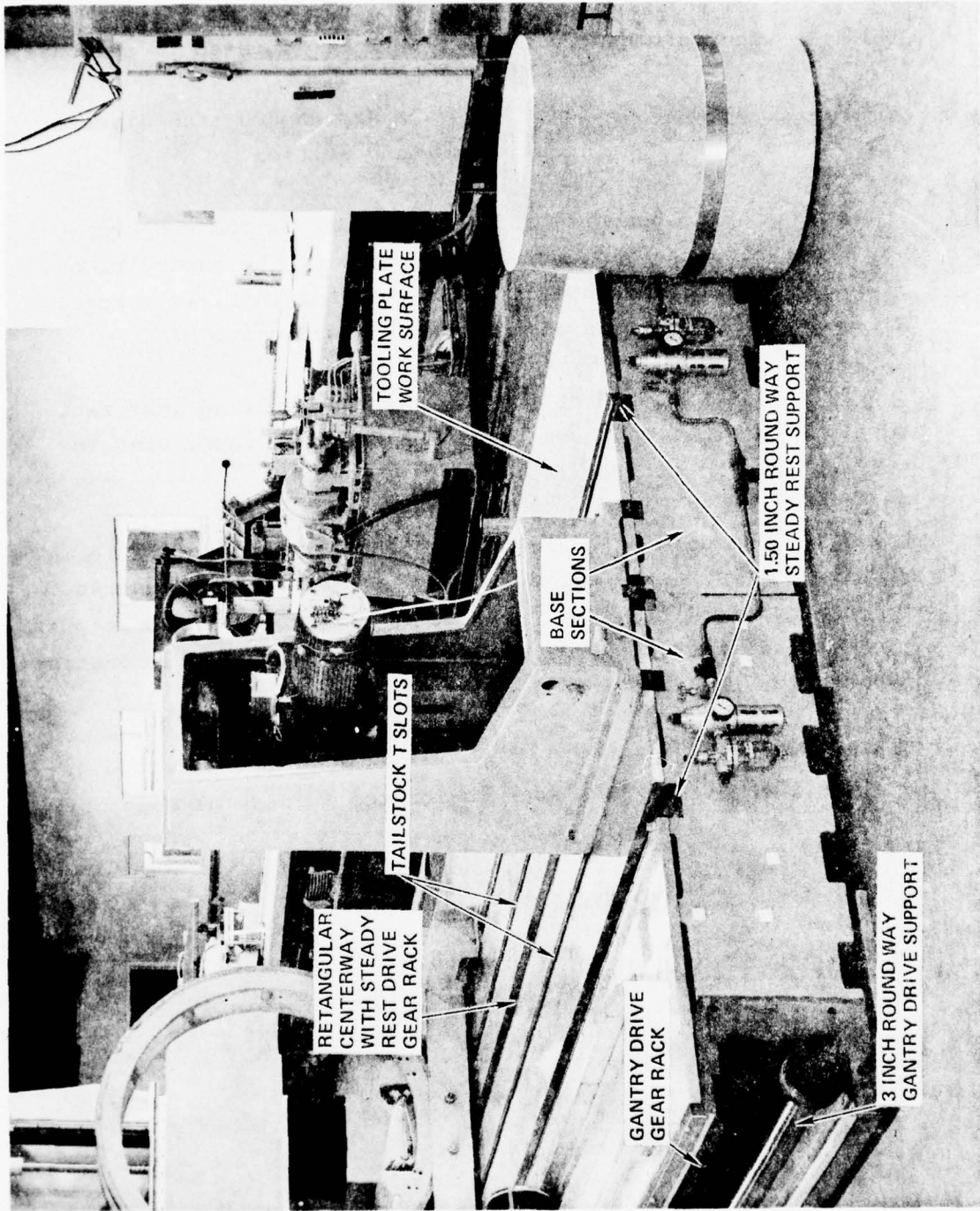

Figure 2. Location of Ways and Tooling Guides

3-3.4 The main gantry support ways are mounted to the base.

3-3.4.1 The main guidance way is a hardened 3 inch diameter bar located on a continuous supporting section.

3-3.4.2 On the opposite side of the base is the supporting way, on which the support side carriage of the gantry rides. The way, made up of a number of butting sections, is a steel section with hard faces at the bearing surfaces.

3-3.5 Also mounted to the base are the driving gear rack sections together with the precision feedback rack, used for the gantry ("X" axis) drive.

3-3.5.1 The driving gear rack is 6 D.P.* with 3 inch face width. The rack is mounted with the teeth facing downwards to prevent dirt from being trapped in the teeth. Also it puts the reacting gear loads directly onto the round ways, mounted beneath the rack sections.

3-3.5.2 The feedback rack consists of many short sections of 1/10 inch pitch. The rack is located against the main drive racks.

* Diametral Pitch

The machine specifications (Appendix I) made recommendations for the gantry construction, under Appendix I sections 3.5.2 and 3.5.3, anticipating the use of aluminum or magnesium structural members.

During the preceding design contract, consideration had been given to aluminum and to a lightweight steel construction for the gantry.

The feasibility of a composite structure was investigated and some static deflection calculations done for a preliminary design layout. The gantry layout, with guidance and drive from one side only, had already been established.

Calculations showed that a composite structure using glass/polyester resin skins and rigid foam core sandwich would be stable enough to achieve the required machine alignments and positional repeatability.

The advantages and disadvantages of metal and composite gantry construction were evaluated.

Metal structures would require welding, stress relieving, machining on large machines, considerable amount of finishing, apart from weighing more and therefore requiring a more powerful drive.

The composite gantry would require a full size mock-up, female moulds, fabrication as a one piece unit complete with gel-coat finish surface.

The knowledge that there would be a future requirement for more machines made the composite gantry structure economically more feasible, since the female moulds would be used again.

To minimize the number of attachment points to the composite gantry, the design utilized the gantry as the main structural member spanning the machine and mounting the smaller detail parts such as bearings and drive gearbox units to two cast aluminum carriages located under the gantry.

Since the gantry is a hollow structure all wiring and air lines were able to be routed through it.

3-4.1 The composite gantry, laid up as a one piece moulding, consists of .180 inch thick glass fabric with polyester resin outer skin, three inch thick rigid urethane foam core, and an inner skin of .125 inch thickness.

The overall dimensions are:

96 inches high by 164 inches wide (across its span)
by 93 inches deep (along the main support side).

3-4.1.1 More details on its construction are contained in Section 4-2 of this report.

3-4.2 The main supporting carriage, on the driving side of the gantry, is an aluminum casting.

Attached to it are the anti-friction way bearings as well as the "X" axis gearbox and motor assembly.

The composite gantry, with attached aluminum interface plate, is located on the top machined surface of the carriage and is fastened with screws tapped into the gantry assembly.

Figure 3 shows the gantry mounted on the carriage assembly.

3-4.2.1 A supporting casting forms the attach point for the main wiring power track which brings all the wires into the terminal strips mounted to a hinged panel on the carriage.

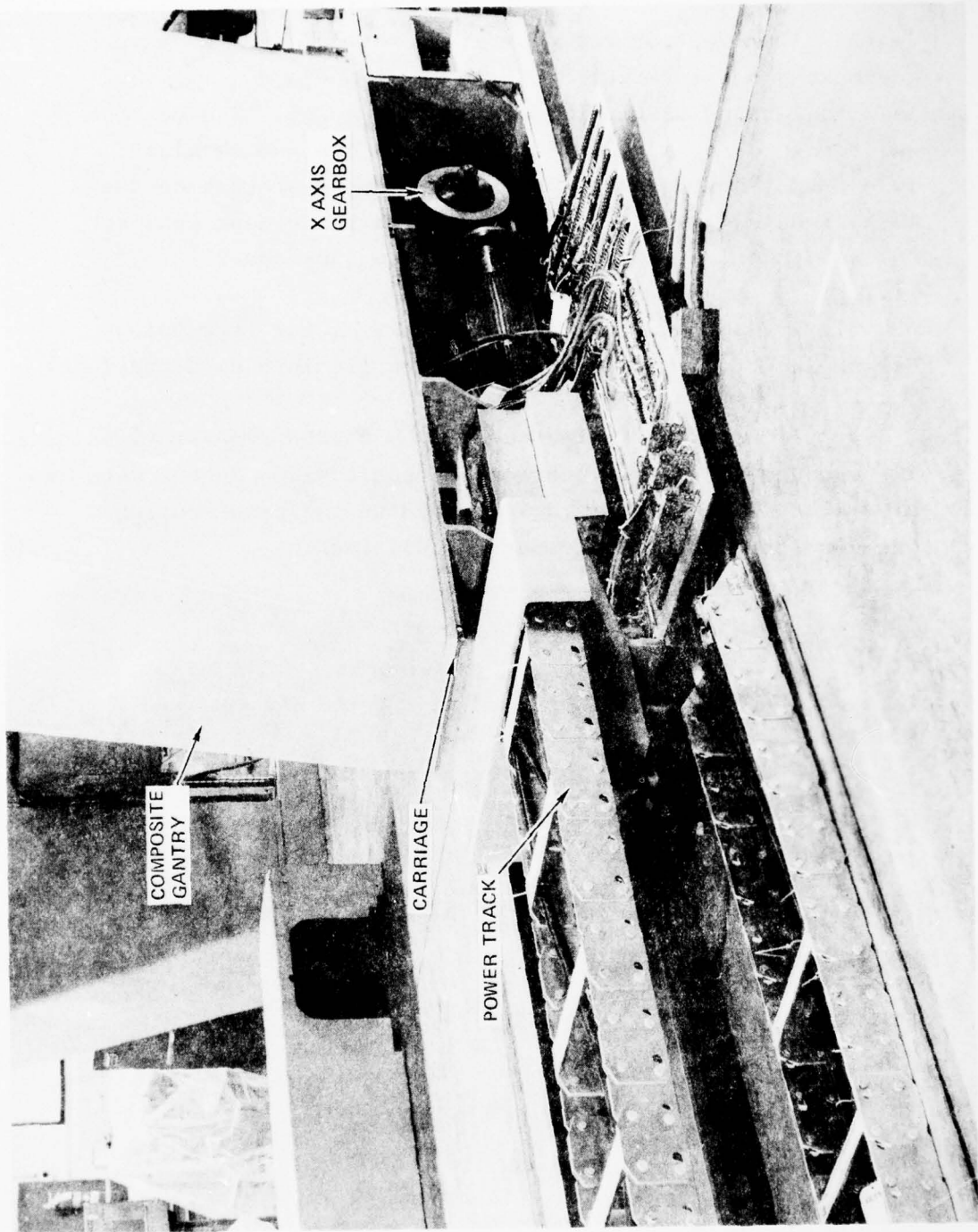

Figure 3. Gantry Mounted on Carriage Assembly

3-4.3 Drive, for the gantry, is through the "X" axis gearbox, shown in Figure 4. The gearbox has a ratio of 10.2 to 1 using a Spiroid Skew axis gear set. The gearbox was designed for maximum rigidity with minimum backlash. Twin output spur gears, meshing with the gear rack on the machine base, are preloaded using a harmonic gear phasing nut and inner torsion bar to eliminate backlash.

3-4.3.1 A permanent magnet D.C. drive motor is coupled to the input of the gearbox through a flexible disc coupling.

3-4.3.2 The "X" axis feedback is by a 2000 lines/rev. encoder. The encoder has a spur gear on its shaft which meshes with the precision feedback gear rack mounted on the base sections. The resolution of the encoder is .001 inch.

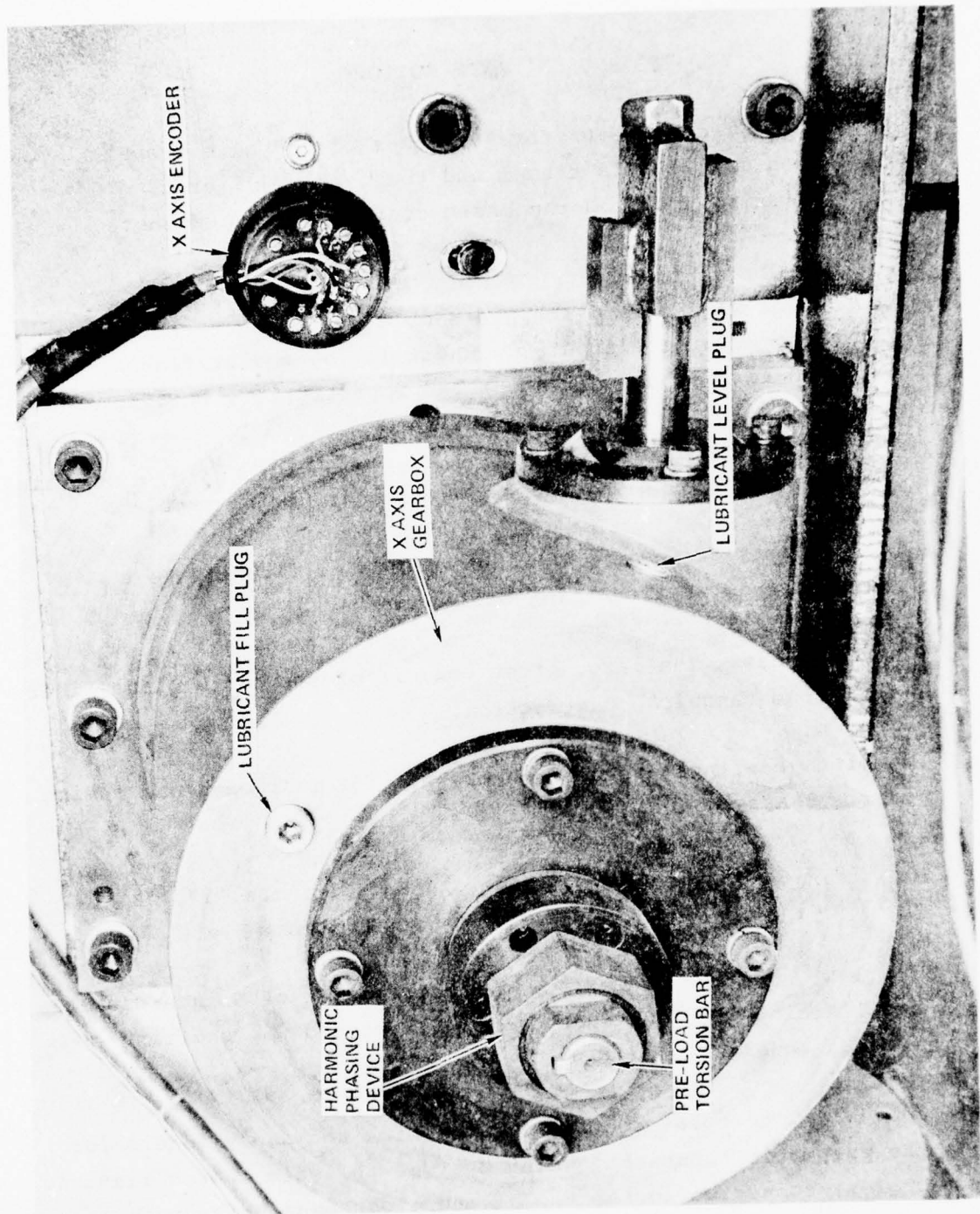

Figure 4. X Axis Drive

3-5 "Y", "Z" AND "A" AXIS MOTIONS

The design requirements for 96 inches of "Y" axis travel, 36 inches of "Z" axis travel and the + or - 45° tilting of the "A" axis, dictated the basic configuration, of these motions.

The design was done to achieve simple lightweight structures for these machine elements, without losing the stiffness required to meet the alignment and repeatability requirements.

For simplicity, a single "Z" axis drive unit is used, overcoming the need for dual drives and their synchronizing problems.

The "Y" axis drive is a D.C. motor coupled directly to a backlash free recirculating ball screw.

For lightness, the large cross beam is of composite glass fiber, rigid foam sandwich construction.

Aluminum castings are used throughout for gearboxes and moving carriage assemblies.

Figure 5 shows the main machine elements for the "Y", "Z" and "A" axes drives, located on the gantry assembly.

3-5.1 The two "Z" axis way tubes consist of 6 inch diameter steel tubing with one inch diameter hardened way shafting located on either side.

3-5.1.1 The tubes contain liners which act as cylinders for the pneumatic counterbalancing system. Plastic coated flexible cables, connected to the top of the cross beam unit, pass over pulleys to the pistons in the cylinders.

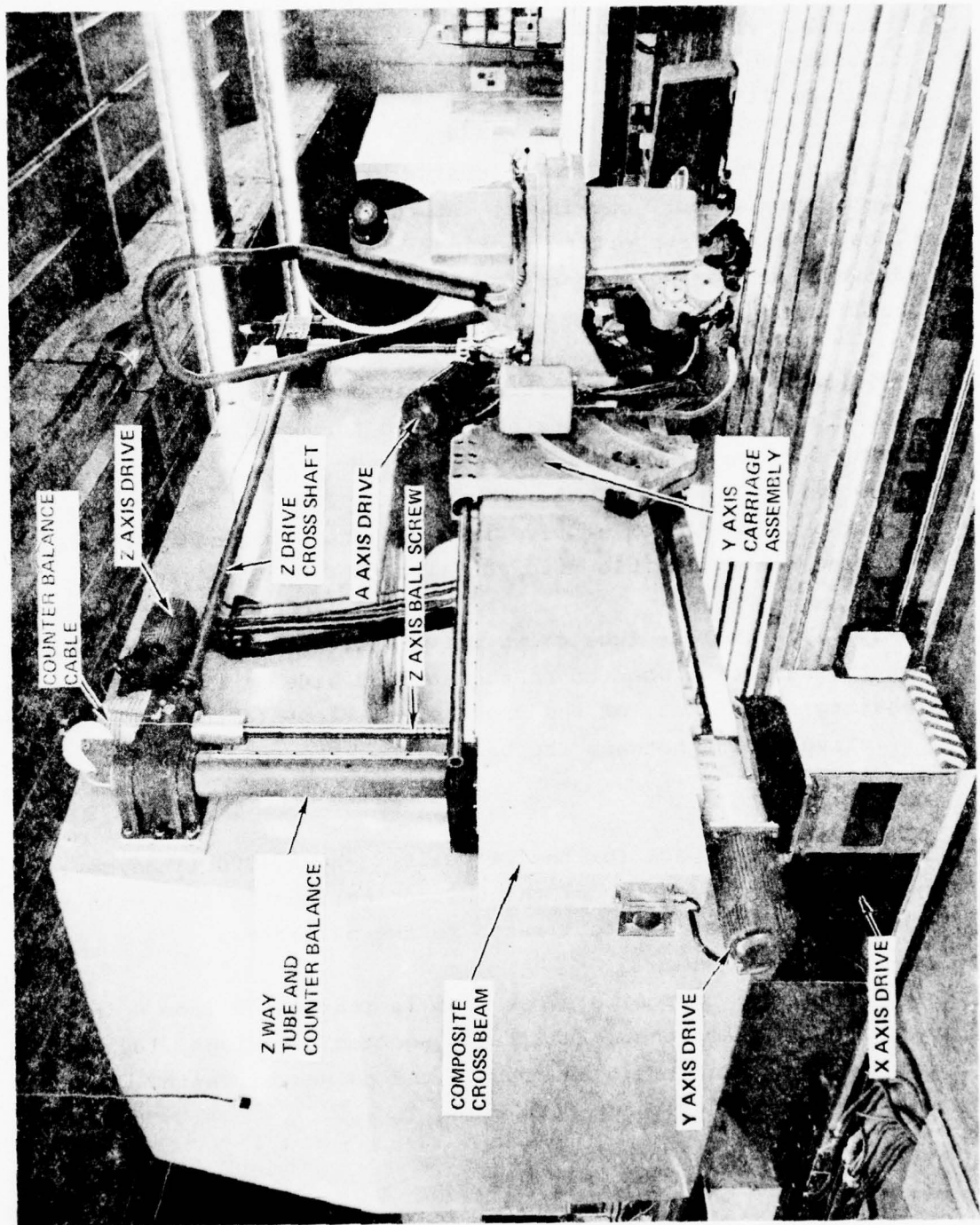

Figure 5. Location of X, Y, Z and A Axis Drives

3-5.1.2 Pressure regulators are set to provide 35 p.s.i. pressure to each cylinder, resulting in a total counterbalance force of 1113 lbs.

3-5.1.3 The way tubes are located at their lower ends to the two gantry support carriages. At their upper ends they are located in two supporting castings which also house right angle drives and bearing support for the two "Z" axis recirculating ball screws.

3-5.1.4 The upper supporting castings are fastened to the interface plates which are bonded and through-bolted to the front surface of the composite gantry.

3-5.2 The "Z" axis drive is a permanent magnet D.C. motor, coupled via a flexible disc coupling to a Helicon gearbox.

3-5.2.1 A torque tube cross drive shaft transmits the drive to the ballscrew mounted on the support side of the gantry. A phasing adjustment, or the cross shaft flexible coupling, allows relative motion between the ballscrews, to adjust the cross beam level.

3-5.2.2 Feed back for the "Z" axis is by a 1000 lines/rev. encoder mounted on top of the Helicon gearbox in line with the output shaft, at a 1 to 1 ratio to the ballscrews.

3-5.3 The composite cross beam is fabricated from 6 inch thick panel sections. Each panel section comprises .180 inch thick outer skins of glass fabric and polyester resin, with 2 lb./ft³ density urethane foam core.

3-5.3.1 The outside edges of the panels are closed by 5/16 inch thick pultruded channel sections specifically designed as a closure for 6 inch thick panels.

3-5.3.2 Aluminum facing strips on the upper and lower surfaces of the beam provide location for the upper and lower ways for the "Y" axis carriage.

3-5.3.3 The upper way is a 2 inch diameter hardened and ground way shaft, hollow for lightness. The way is mounted on a tee shaped supporting section fastened to the top surface of the beam.

3-5.3.4 The lower way is a 1 inch square steel bar with hardened surfaces.

3-5.3.5 Aluminum weldments fastened to the cross beam carry the recirculating roller guides for the "Z" axis motion and also locate the flanges of the "Z" ball screw nuts.

3-5.4 The "Y" axis drive motor is the same as the "Z" axis, a permanent magnet type, with integral tach. generator. The motor mounts to an aluminum casting, which also houses the two bearings supporting one end of the recirculating ball screw.

3-5.4.1 The other end of the 1 inch pitch thread ball screw is located in a housing that also carries the 1000 lines/rev. digital feedback encoder for the "Y" axis motion. This is shown in Figure 6.

3-5.5 The "Y" carriage assembly comprises an aluminum casting to which is mounted the segment gear and curved way for the "A" axis motion.



Figure 6. Y Drive Axis- Gantry Support Side

3-5.5.1 The carriage runs on recirculating ball bushings on the upper round way, and is located with cam follower rollers bearing on the lower square section way.

3-5.5.2 A bracket mounted to the rear of the "Y" carriage casting is attached to the flange of the recirculating ball screw nut, providing the drive to the carriage.

3-5.5.3 The gear segment drive for the "A" axis also provides the upper way guidance for the "A" carriage.

3-5.5.4 Weight of the "A" carriage, with attached tape placement head, is carried on the curved lower way.

3-5.6 The "A" axis drive is by a permanent magnet D.C. motor through a skew axis gearbox to a spur gear meshing with the segment gear, on the face of the "Y" carriage. Figure 7 shows the motor and gearbox unit.

3-5.6.1 Feedback is provided by a 1000 lines/rev. encoder driven from the input shaft of the gearbox through anti-backlash gearing.

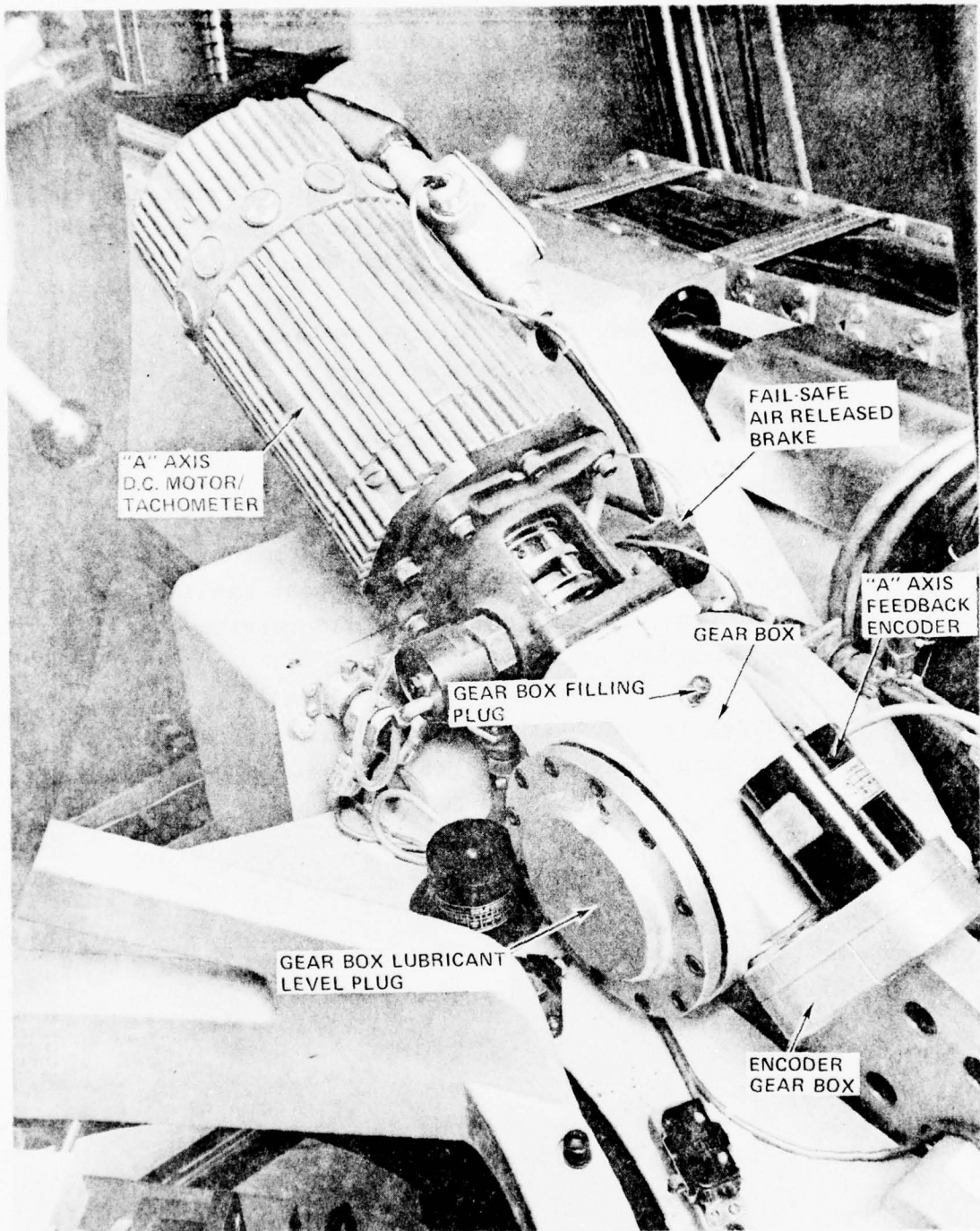

Figure 7. A Axis Drive

3-6 TAPE PLACEMENT HEAD

The Tape Placement Head (Figure 8) consists of a frame attached to the "A" Axis Carriage of the ATLAS and on which are mounted the various component assemblies. These include the the Payoff Reel, the Takeup Reel, the Placement Roller, the Tape Shear, the Infrared Heater, the Tape Slitting Assembly, the Guide Shoe and the Loop Box (dancer arms). In addition to these components the Tape Placement Head contains drive motors, encoders, pneumatic regulators and valves, control devices and all required electronics.

The head is a self-contained unit requiring only power, air, and command signals from the numerical control system.

This section of the report covers the various features of the Head, from the pay-off reel down to the placement roller.

3-6.1 Main Frames and "C" Axis Drive

The main frame of the tape head is mounted to a ring assembly which rotates within the supporting tape head bracket. A pair of cross roller bearings provide the rotational support, and a ring gear, shown in Figure 9, mounted underneath, is driven by the "C" axis motor assembly.

3-6.1.1 The "C" axis motor assembly consists of a permanent magnet D.C. torque motor with integral tach. generator, which drives the ring gear through a set of spur reduction gears.

3-6.1.2 The feedback device, a 2000 lines/rev. encoder is mounted on the top of the motor assembly and protrudes through the bracket casting for ease of access. Figure 10 shows the encoder, and the "C" axis rotational stops.

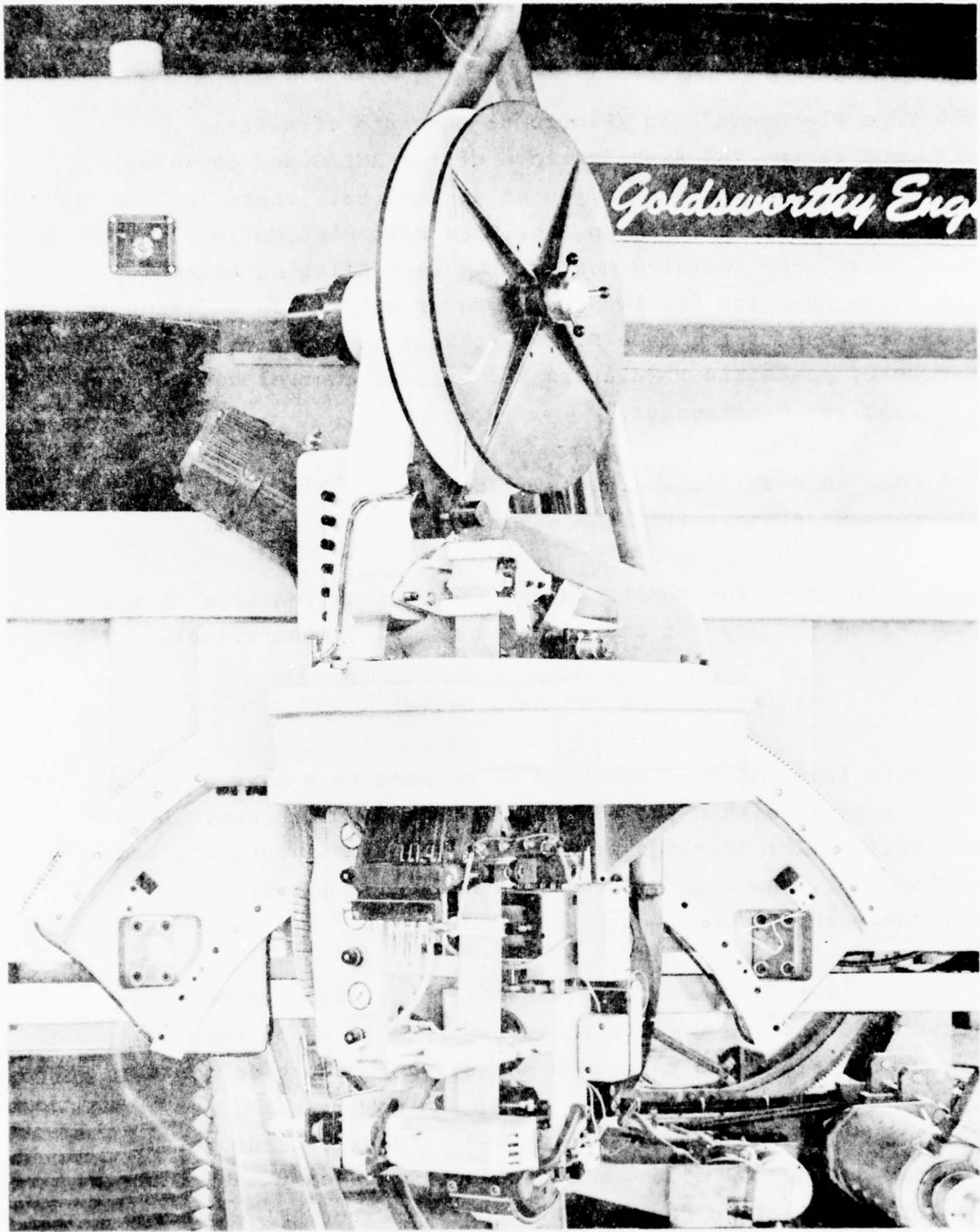

Figure 8. The Tape Placement Head

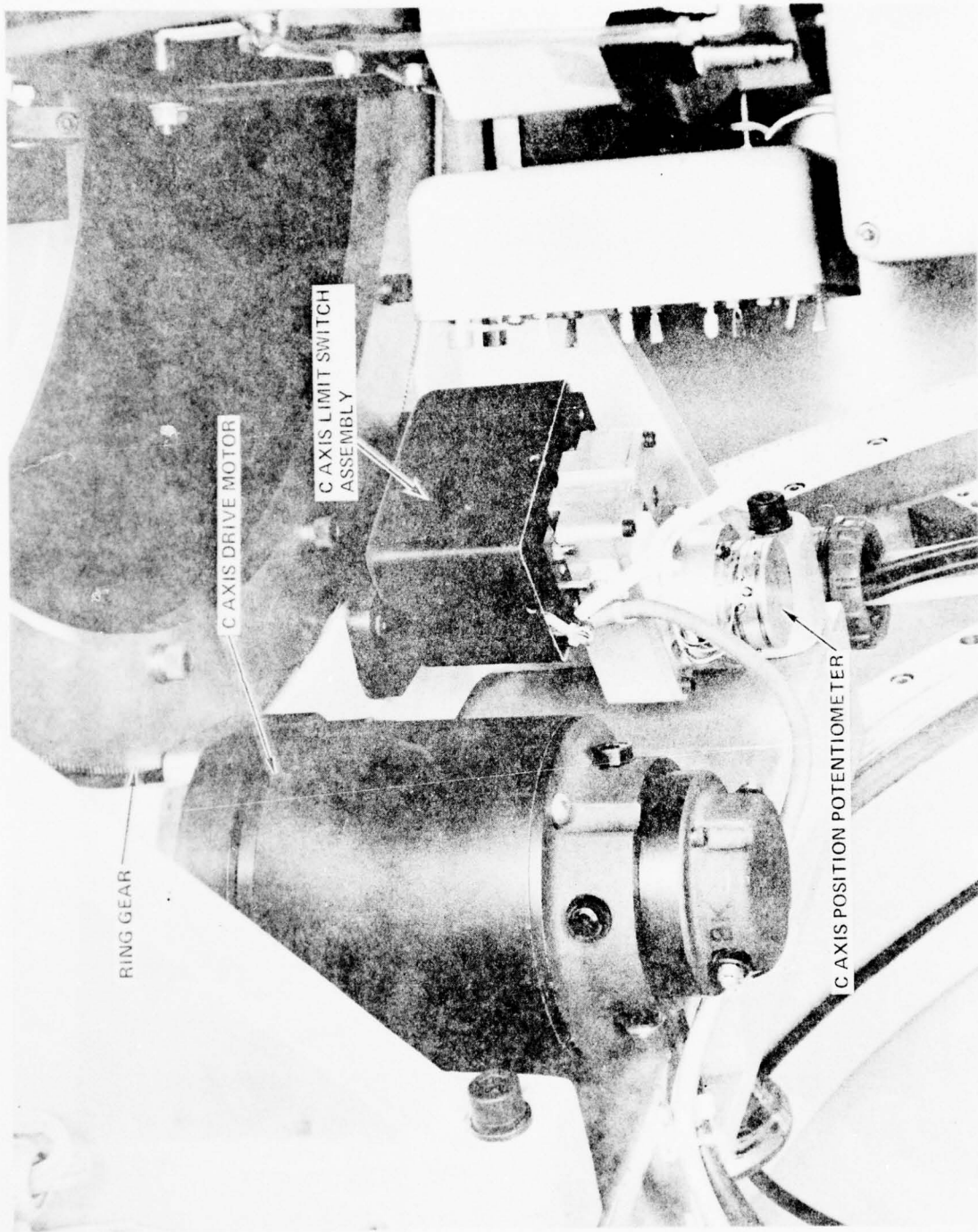

Figure 9. The C Axis Drive Motor

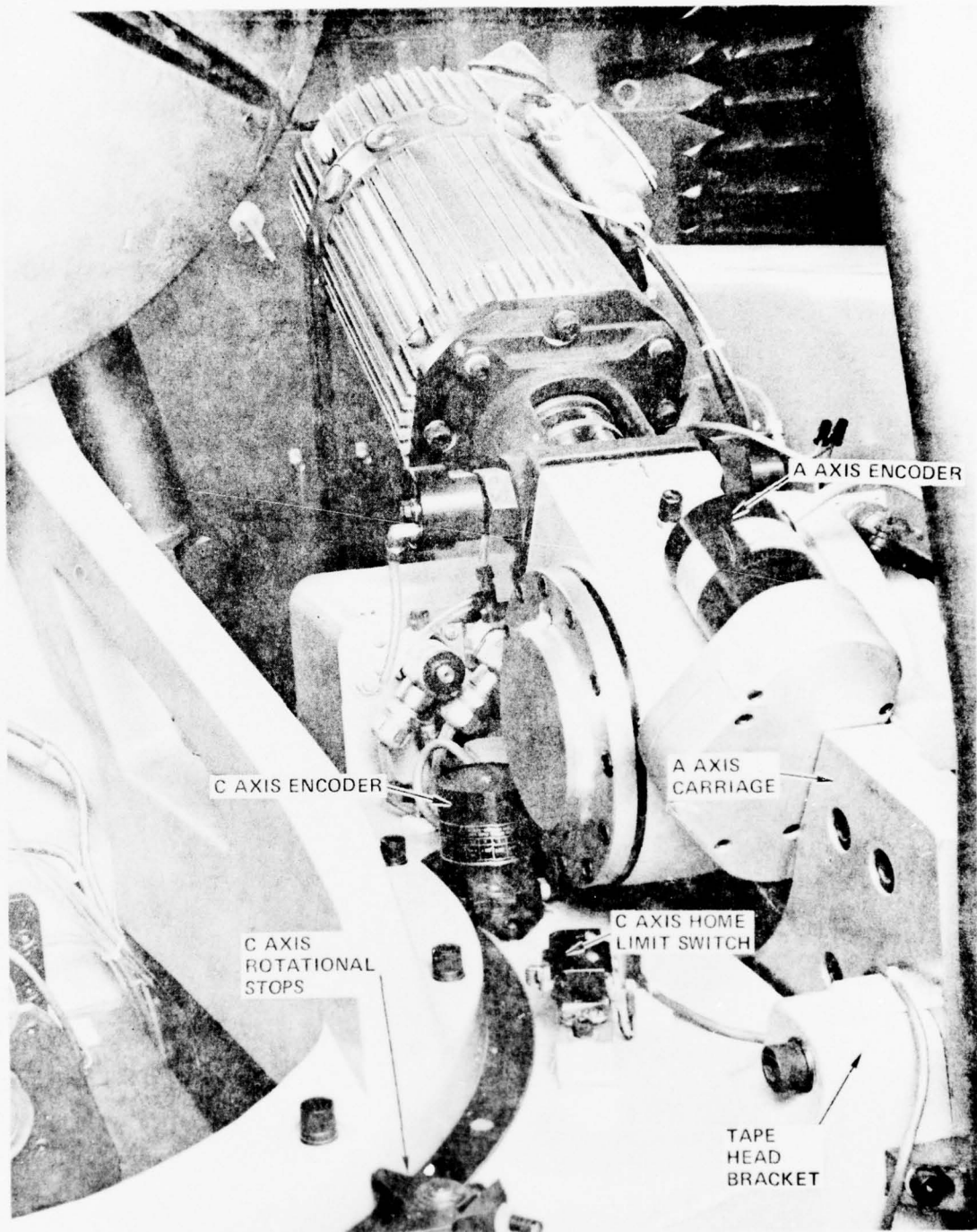

Figure 10. A Axis Carriage Assembly

3-6.1.3 The positive rotational stops are arranged to limit the tape head rotation to 405°.

3-6.1.4 The limit switch assembly, shown in Figure 9, is geared from the ring gear, to provide overtravel and emergency stop signal at each end of the travel, as well as a switch for setting the home position in conjunction with a reference signal from the encoder.

3-6.1.5 The maximum speed of rotation, of the tape head, is 10 rpm. This gives a 180° rotation time of 3 seconds.

3-6.2 The Payoff Reel

The payoff reel (Figure 11) includes the spindle, flanges and a magnetic particle clutch. The detachable 24-inch reel can accommodate up to 3500 feet of 3-mil paper-backed composite tape in three inch widths on a 3-inch core. An adapter is supplied with the tape head assembly to permit the use of an 8-inch core, usually used with boron-filament impregnated tapes.

3-6.2.1 The flanges are faced with teflon sheet to prevent excessive drag when the tape is unspooling, and is readily cleaned to remove resin deposits.

3-6.2.2 The payoff reel load sensor consists of a pivoted arm which bears against the tape spool contained on the reel. When the spool diameter decreases to a size equivalent to 25 lineal feet of tape, the arm position triggers a limit switch which energizes an audible alarm mounted on the numerical control panel.

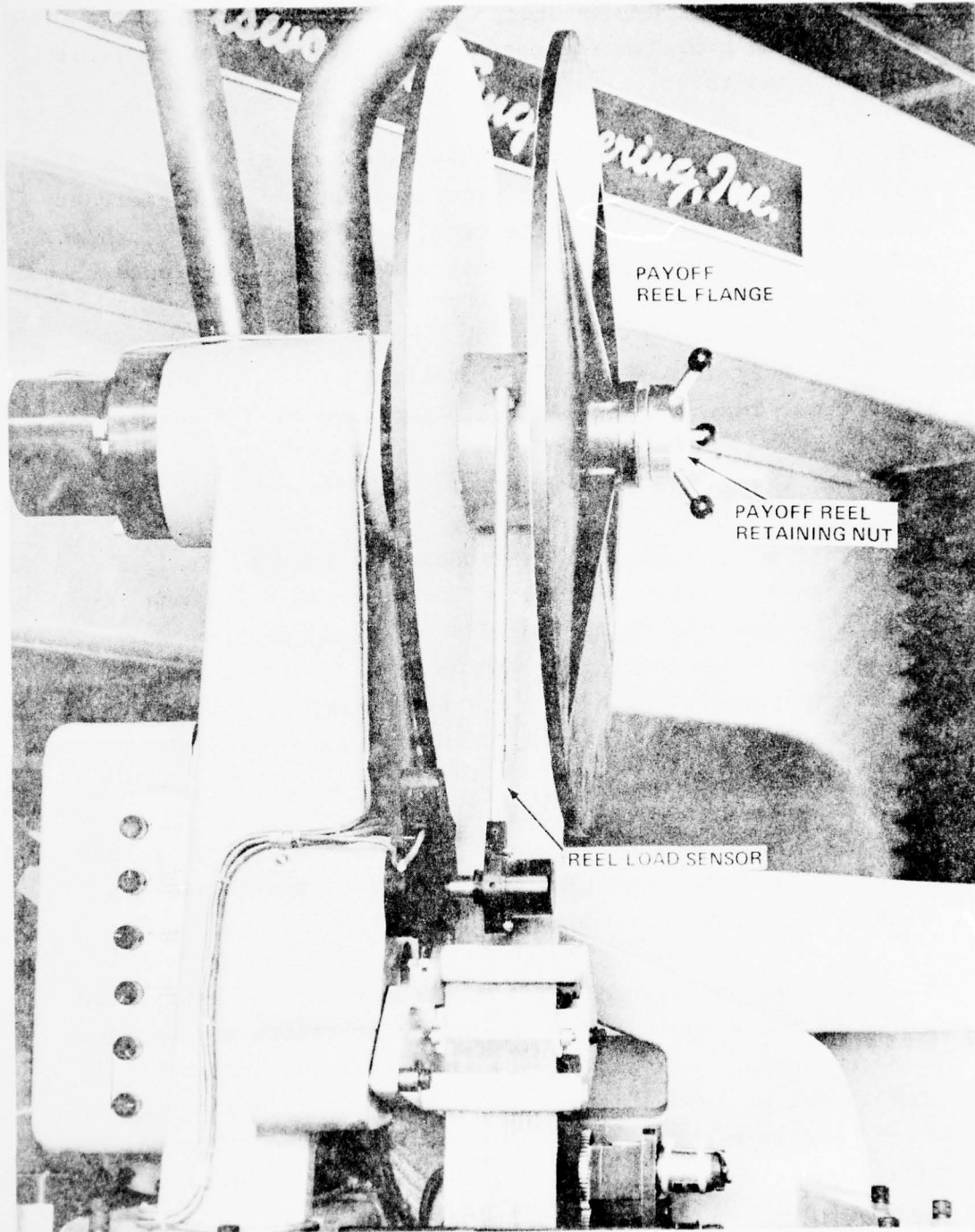

Figure 11. The Payoff Reel and Load Sensor

3-6.3 The paper takeup reel (Figure 12) includes a spindle, a reel sub-assembly and a gear motor and clutch. The detachable 12-inch reel can accommodate up to 3500 feet of 3-mil paper backing/liner in three inch widths on a 3-inch core or with no core. (The reel hub is slotted to accept paper.)

3-6.3.1 The reel drive two speed gear box is used to generate more torque during the "comb-out" cycle following a tape slitting pass.

3-6.3.2 The reel drive motor runs at a constant speed and the amount of tension in the paper being wound up is adjustable via the variable torque clutch.

3-6.3.3 Also as a part of the paper takeup system, a rubber bladed "chicken plucker" paddle wheel opposed by a teflon roller, creates a pulling force on the individual slit paper strips leaving the placement unit. The slit strips are then guided through a roller system before being spooled up on the takeup reel.

3-6.4 The Tape Shear Unit, shown in Figure 13, is mounted in the placement assembly fork. Since the shear and the placement roller are both mounted on the fork, relative positions of the two are not changed when the placement assembly moves. (It has a travel of + or - 1/2 inch.)

3-6.4.1 The tape shear consists of a supporting frame which is mounted to a spindle. The supporting frame has two air cylinders attached to it and a replaceable teflon shear anvil. The shear blade is mounted to a platen driven by the air cylinder.

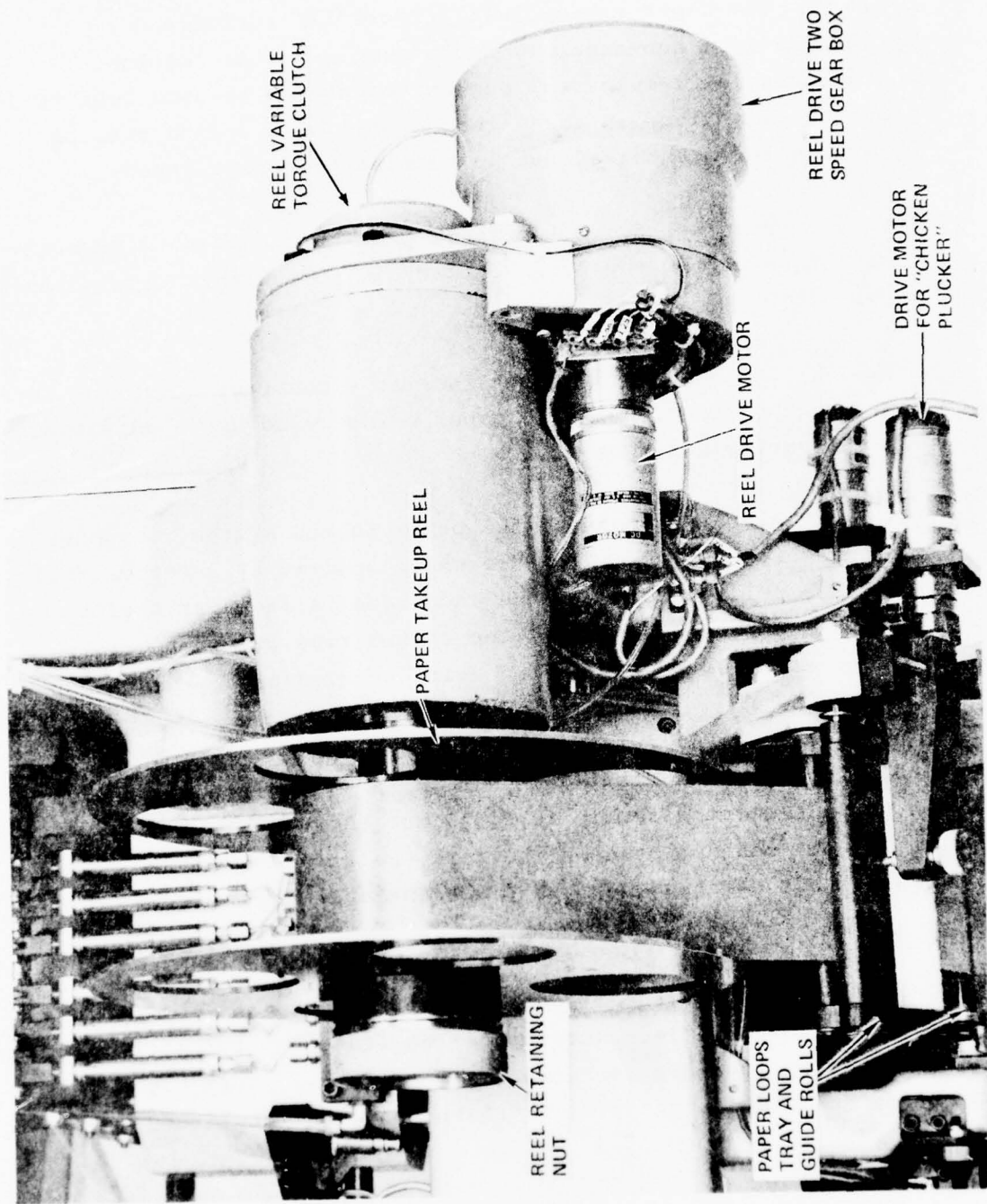

Figure 12. The Paper Takeup Reel

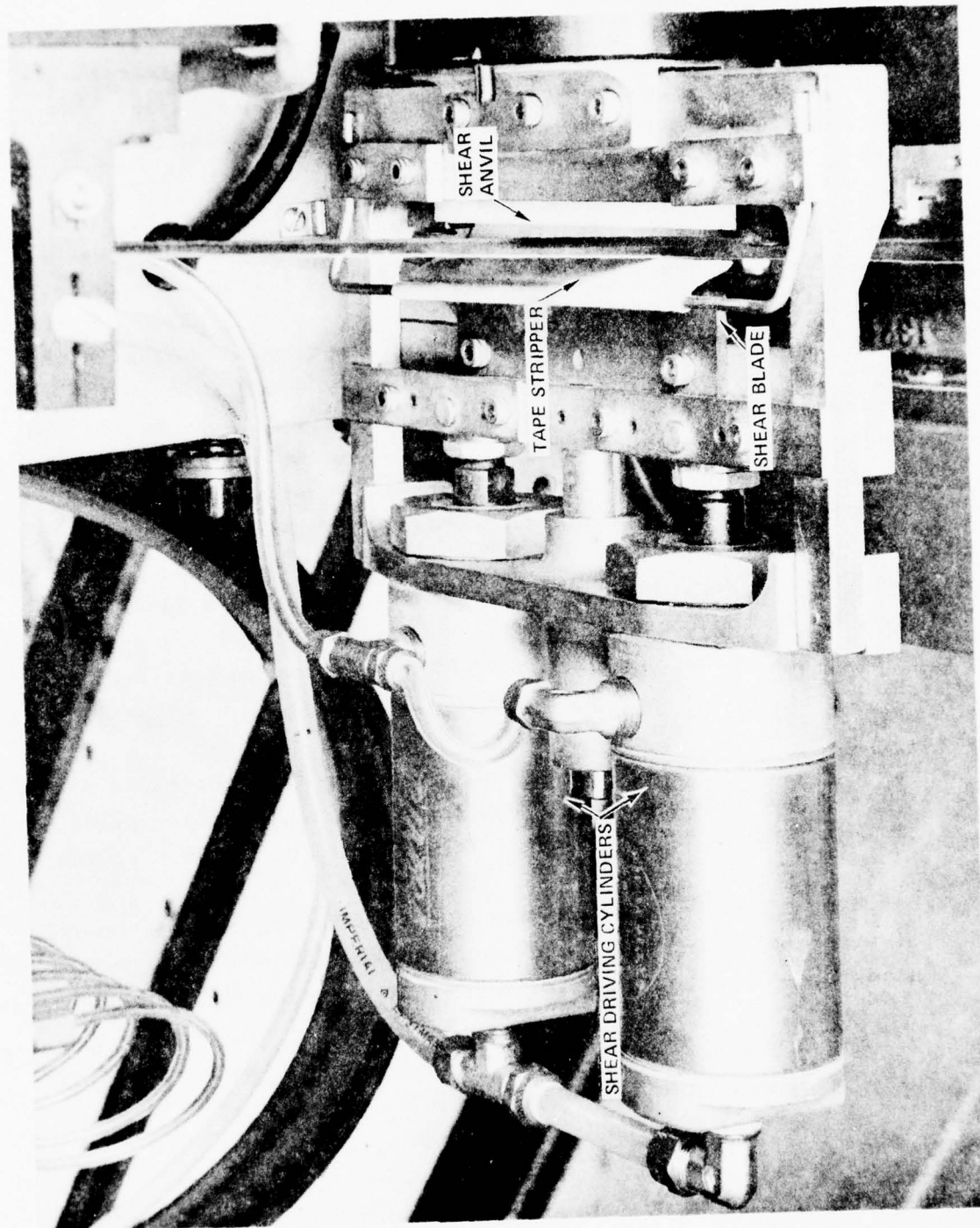

Figure 13. The Shear

3-6.4.2 The centerline of the spindle, seen in Figure 14, coincides with the center of the anvil and shear blade. The shear spindle, mounted in bearings through the placement assembly fork, is driven by means of a small D.C. geared motor.

3-6.4.3 A 10 turn potentiometer, geared to the shear spindle, provides analogue feedback for positioning the spindle angle.

3-6.4.4 Shear angle commands, programmed by "S" words in the numerical control, are conveyed in binary coded form to the decoder which sets up the appropriate analogue signals for the shear angle drive. The angles can be set in one degree increments + or - 45° from a horizontal position of the shear, which corresponds to a straight cut across the tape.

3-6.4.5 A straight cut is programmed by either a S0 or S50 command to the control. A +45° cut is programmed S95 and a -45° cut is programmed S5. The "S" word program goes from S5 thru S95.

3-6.4.6 The shear is designed to cut the filament tapes without cutting the backing paper. Use of the correct backing paper, green in color, (Ref. No. RM 5250 3M Co.) ensures reliable performance.

3-6.4.7 The air pressure to the air cylinders and the length of time the cylinders are pressurized are both variable settings used to set up the shear for different material conditions.

3-6.5 The infrared tape heater, shown in Figure 14, is used to preheat the tape prior to the point of placement.

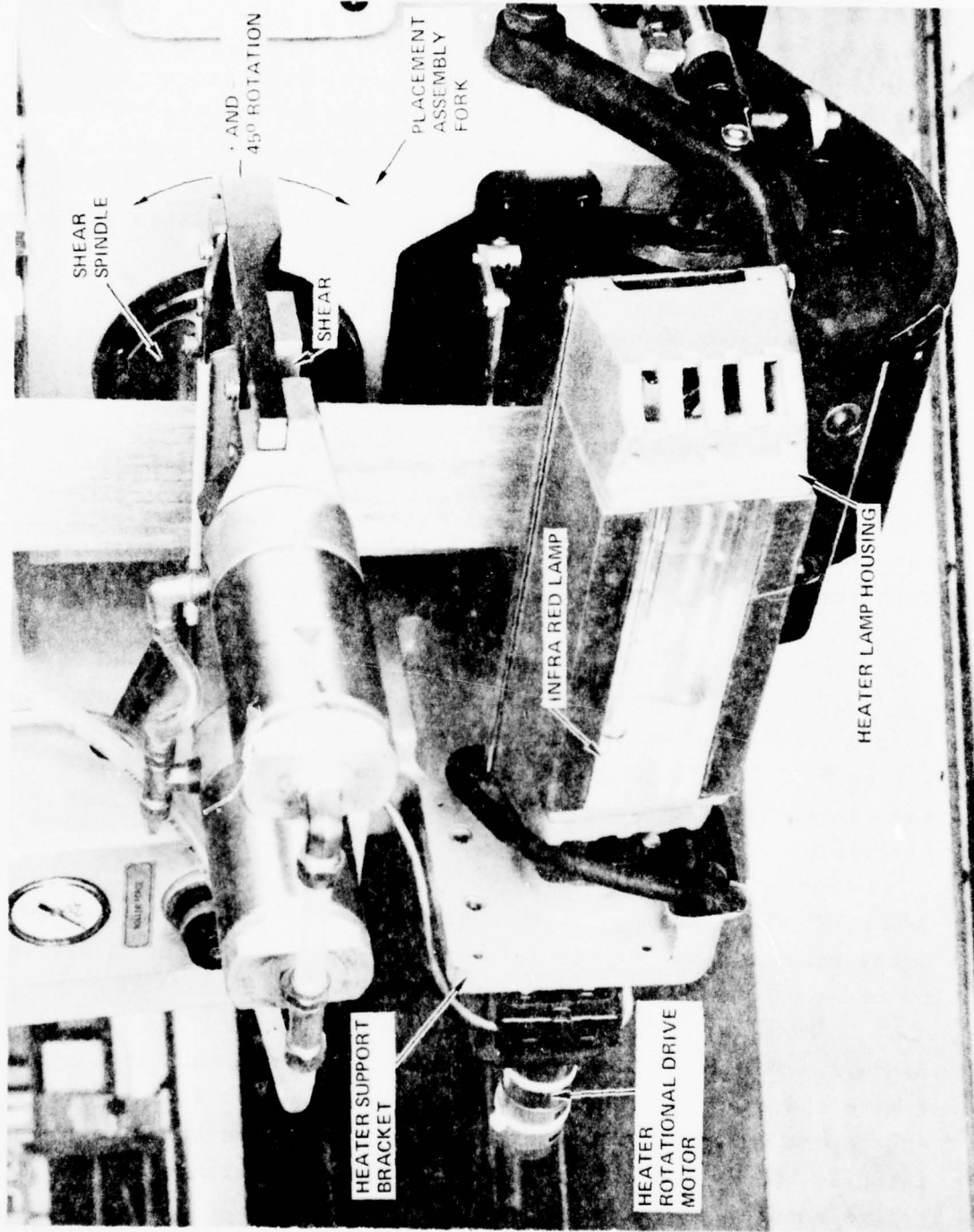

Figure 14. The Heater and Shear

3-6.5.1 The parabolic reflector unit is mounted on a powered rotating housing. On command, when tape is starting to feed through the tape head, the housing rotates 180° to aim the heater at the tape. At the same time the heater is turned on.

3-6.5.2 The amount of heat is controlled by a variable controller with a hand operated potentiometer setting.

3-6.5.3 As soon as the tape ceases to feed through the head the heater rotates back and the heat is simultaneously turned off.

3-6.6 The Tape Slitting Assembly shown in Figure 15 and 16, is a unique feature of this Tape Placement Head. The purpose of the unit is to slit the 3 inch wide tape into equal width strips, and to control the tension in the individual slit strips by means of a Tape Loop Dancer System.

When the tape head starts to lay tape on a compound curved surface, the Tape Slitter is activated. When the slit width tape starts to be laid up on the compound curved surface, some of the strips will have a greater length demand than others. This differential between the strips is taken up by the Tape Loop Dancers.

3-6.6.1 The Slitting Knives consist of two sets of discs with equal thickness spacers in between. One set of knives is driven by means of a D.C. motor and a variable torque clutch.

3-6.6.2 The discs are hardened and precision ground tool steel, as are the spacers. The two knife units are brought into engagement by an air cylinder. The knives on one coincide with the disc spacers on the other set. Minimum clearance between the knives ensures clean cutting of all fibers.

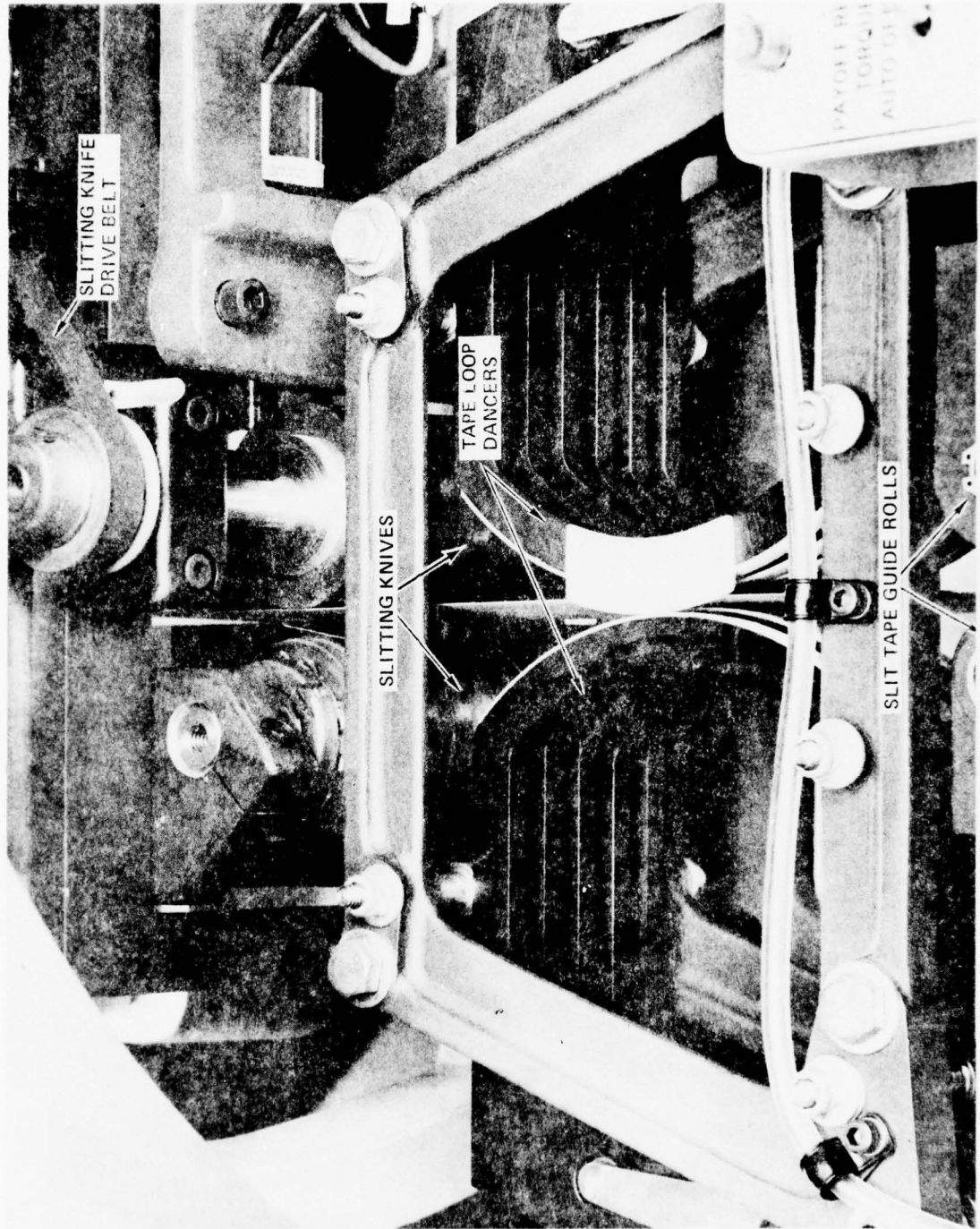

Figure 15. The Slitting Assembly

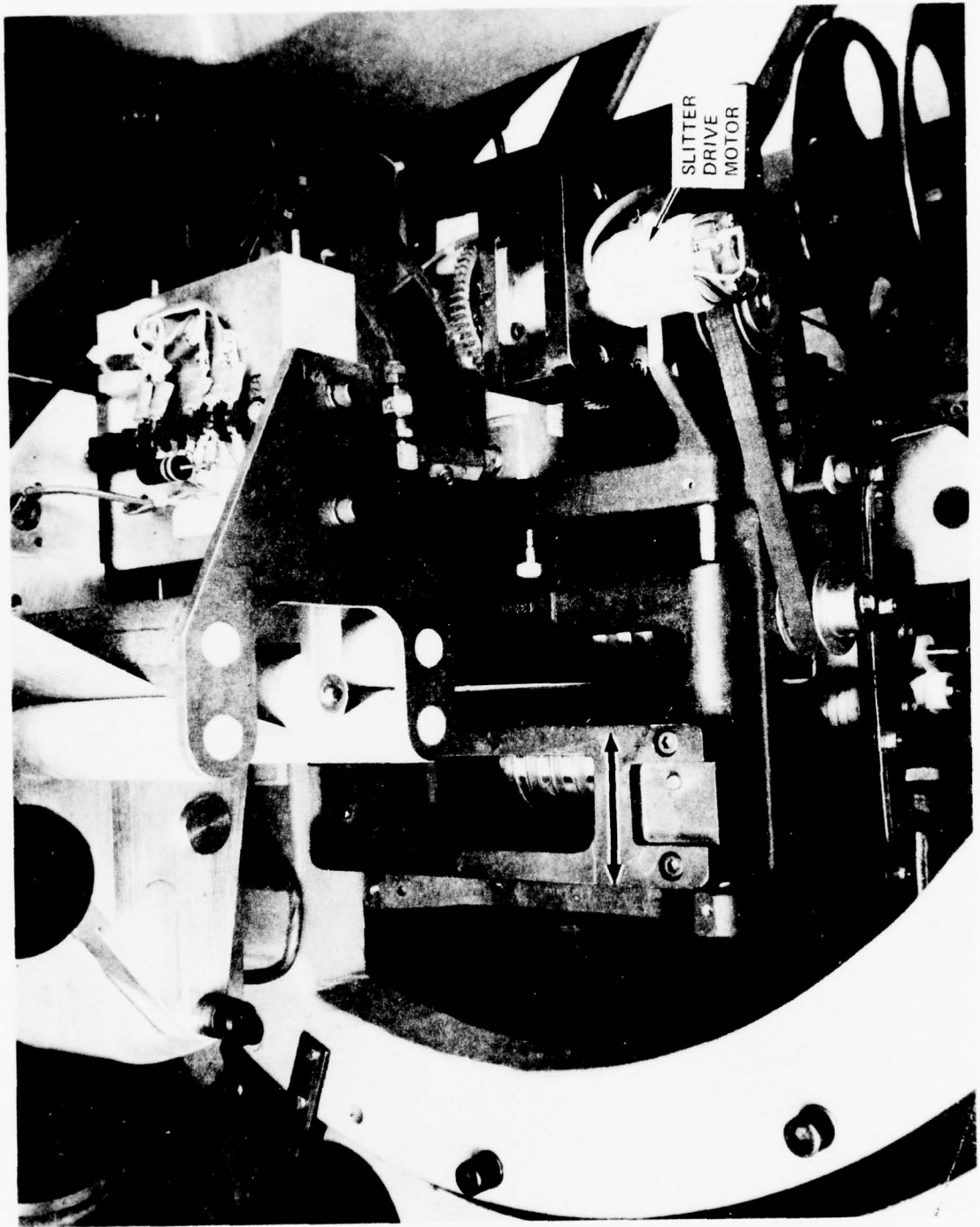

Figure 16. Slitting Assembly-Top View

3-6.6.3 Urethane rings, with teflon outer surface covering, surround the spacer discs acting as strippers to prevent cut strips from adhering to the knives when slitting ceases.

3-6.6.4 The Tape Loop Dancers consist of aluminum frames with curved edges covered with teflon. The frames are located on free running bearings, giving them frictionless sliding motion. Air cylinders, behind the frames, force them to move inwards on command. Air pressure to the cylinders is regulated to set the tension of the tapes passing over the face of the dancers.

3-6.7 The Placement Roller shown in Figure 17, was designed to meet the requirement of the tape head to be able to layup on surfaces of 2 inch radius. The inflatable tire, mounted on an aluminum hub with securing flanges is able to rotate freely on bearings mounted on an axle.

3-6.7.1 The axle registers in a tapered location at each end and is held by two easily removeable retaining pins. This same location is used by the line follower unit described in Section 4-5.

3-6.7.2 A report on the inflatable tire performance is given in Appendix II.

3-6.7.3 Development of other placement units was done during the Contract. These are covered in Sections 5-3.3 through 5-3.6. The placement units, using the same axle location points, replaced the roller and shoe described in this section.

3-6.7.4 Associated with the placement roller is the Guide Shoe, shown in Figure 17. This unit, powered by two air cylinders, guides the tapes, particularly boron, around the

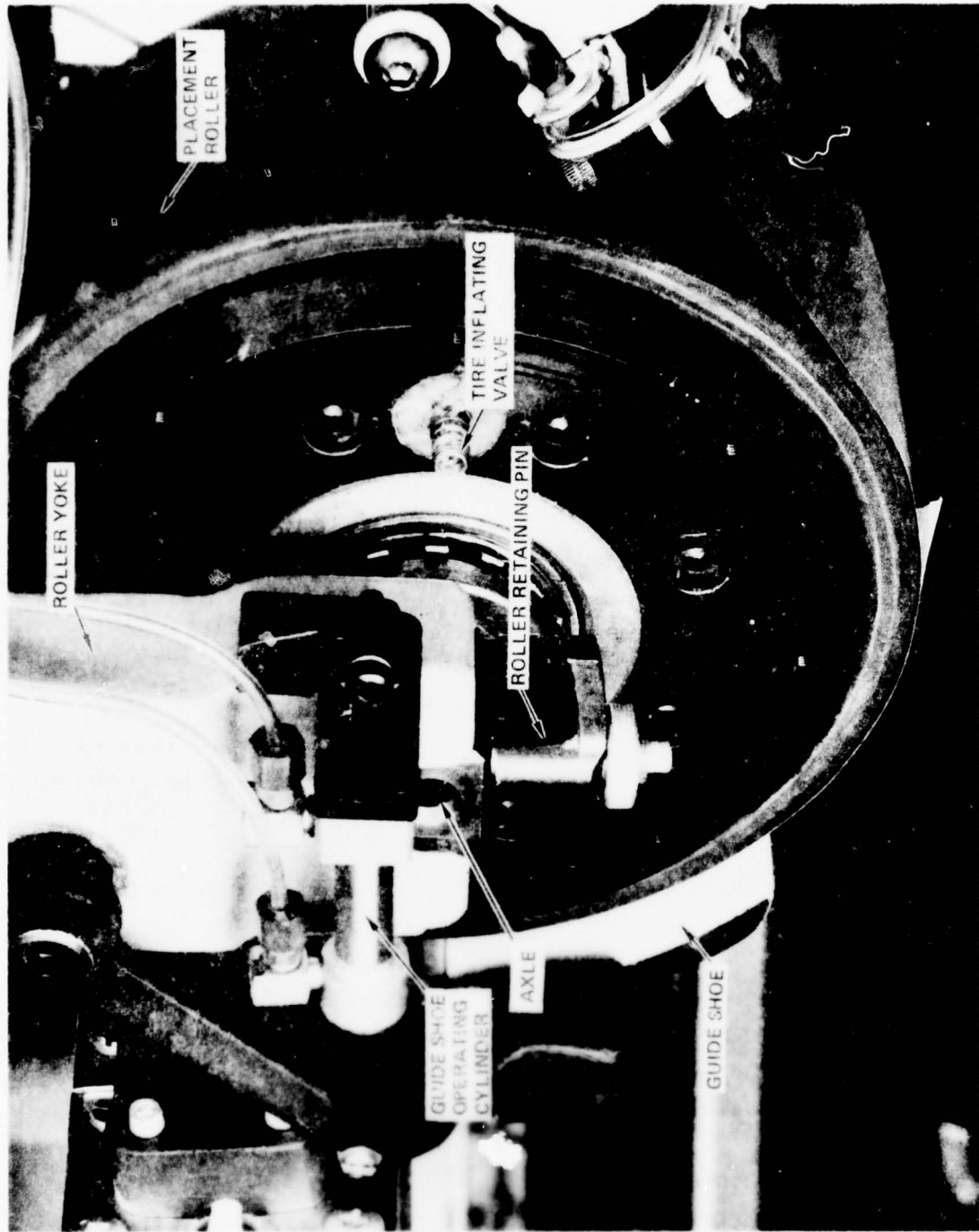

Figure 17. The Tape Placement Roller

front of the placement roller. At the end of a tape layup pass the guide shoe is clamped to the placement roller preventing its rotation and holding the tape in place.

3-6.8 The Tensiometer (Figure 18) provides a means of controlling the drag torque existing on the Payoff Reel magnetic particle clutch. Included in the mechanism is a Tachometer Generator which provides a speed sensitive signal to the head electronic control system.

3-6.9 Tape Head Controls

The self contained controls for the Tape Head functions are contained in three places on the Head:

- Main Control Panel
- Auxiliary Control Panel
- Pneumatic Control Panel

3-6.9.1 The Main Control Panel for the Tape Placement Head (Figure 19) provides those controls most frequently used for both manual and automatic (programmed) operations.

3-6.9.1.1 Payoff Reel Torque - This three-position, center OFF device enables the operator to place control of the Payoff Reel Drag Torque under automatic tape tension control (AUTO position) or set it at a fixed value (ON position) by using the Payoff Reel Drag Torque Knob located on the Auxiliary Control Panel (Paragraph 3.6.9.2.2.)

3-6.9.1.2 Shoe - This three-position device enables the operator to cause the pneumatically actuated Guide Shoe to retract by selecting the OUT position or to "clamp" by selecting the IN position. In the AUTO position, the Shoe will retract and clamp in accordance with programmed instructions.

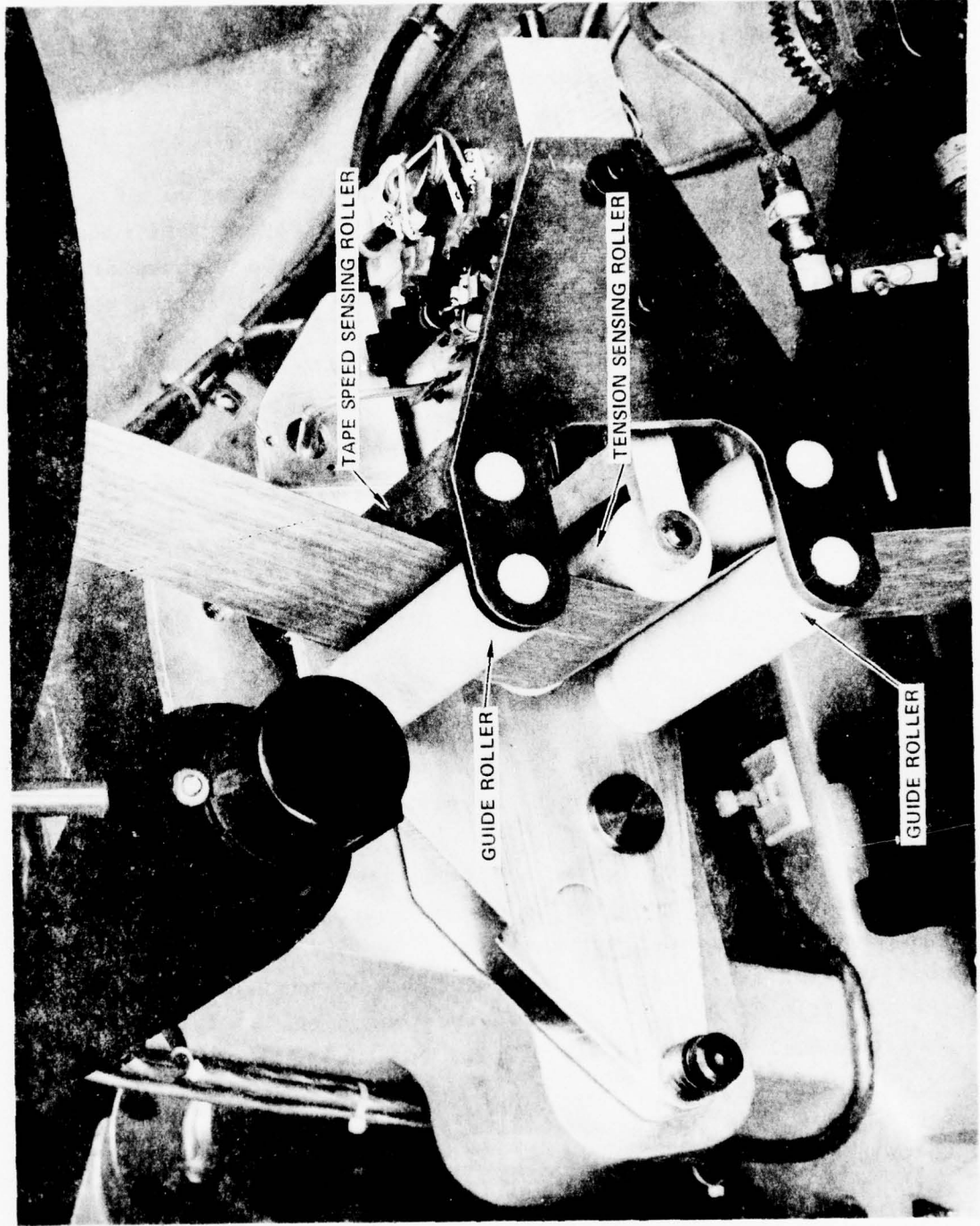

Figure 18. The Tensionmeter

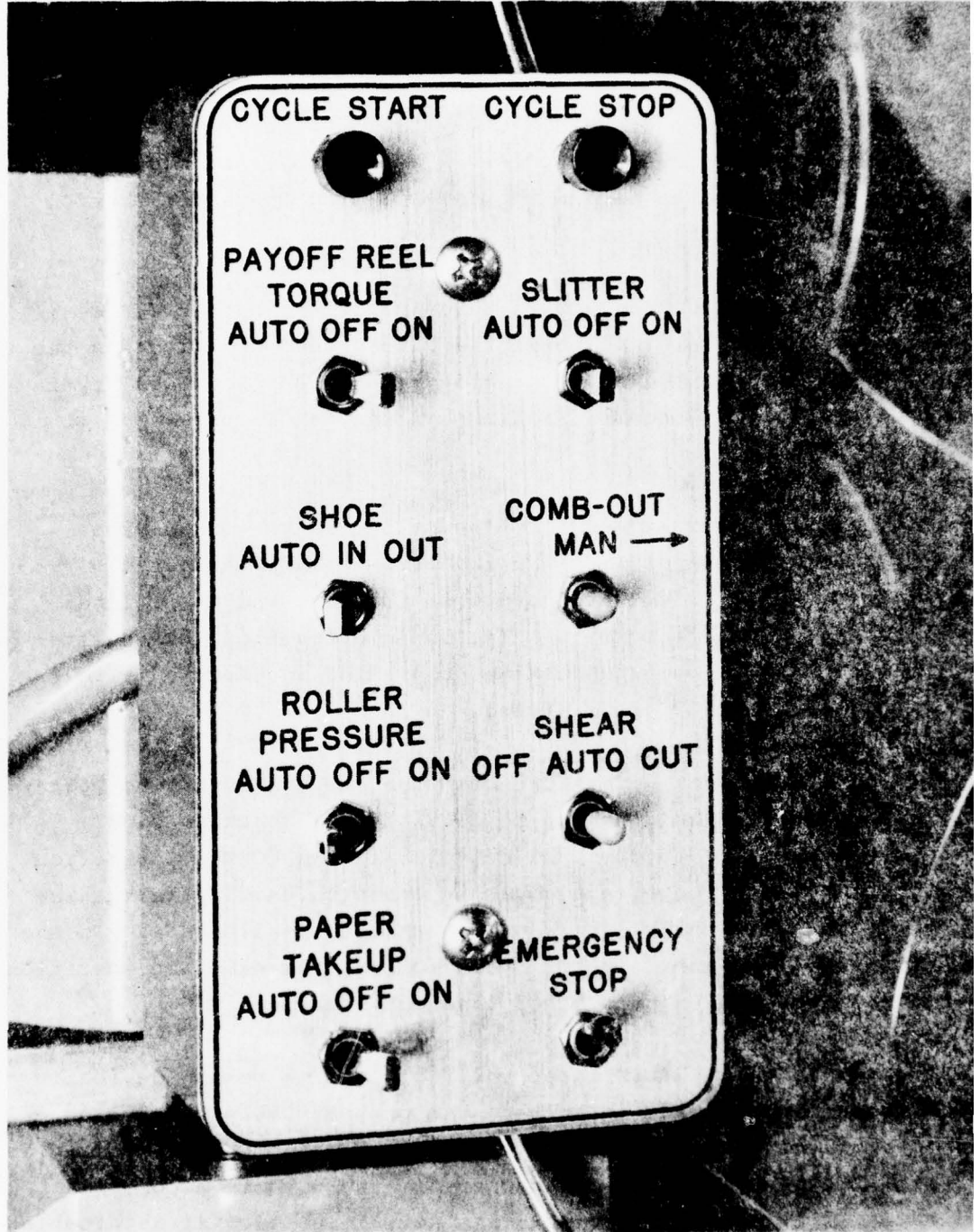

Figure 19. Tape Head Control Panel

3-6.9.1.3 Placement Roller Pressure - This three-position, center OFF device enables the operator to turn the Placement Roller pressure ON or OFF manually or to select the AUTO mode for production runs. The pressure is variable and may be controlled with the bottom regulator on the Pneumatic Control Panel.

3-6.9.1.4 Paper Takeup - This three-position, center OFF device enables the operator to power the Takeup Reel by selecting the ON position. In the AUTO position, the Takeup Reel will synchronize with the Placement Roller and in the OFF position, it is disabled.

3-6.9.1.5 Slitter - This three-position, center OFF device enables the operator to cause the pneumatically actuated slitting discs to converge and slit the tape and paper liner into strips of equal width. In the AUTO position, the Slitter will actuate in accordance with programmed instructions; in the OFF position it is disabled.

3-6.9.1.6 Comb-out - This two-position, spring return-to-center device enables the operator to initiate the (backing paper) combout cycle by holding the selector in the COMB-OUT position. It is the function of the comb-out cycle to enable the machine to again continue its programmed path with unslit tape. In the AUTO position, the comb-out cycle follows the slitting operation in accordance with programmed instructions.

3-6.9.1.7 Shear - This three-position, spring return device enables the operator to actuate the pneumatically controlled shear mechanism by selecting the spring-loaded CUT position. In the AUTO position, the shear operation is done in accordance with programmed instructions; in the OFF position it is disabled.

3-6.9.1.8 Emergency Stop - This momentary-on device parallels all other emergency stop circuits within the system and accomplishes the same results; the immediate and complete shut-down of the system. It is reset from the MCU* main control panel by depressing the E-STOP RESET push button and resetting the BUZZER.

3-6.9.2 The Auxiliary Control Panel (Figure 20) contains six continuously variable resistors which are seldom used regulatory devices which regulate the Paper Takeup, Shear Control and Slitting devices and, in addition, provide a means of regulating the output of the Infrared Heater.

3-6.9.2.1 Heat - This continuously variable resistor enables the operator to vary the output of the Infrared Heater to obtain the desired amount of "Tackiness".

3-6.9.2.2 Payoff Reel Drag Torque - This continuously variable resistor enables the operator to vary the amount of drag being applied to the Payoff Reel by the Magnetic Particle Clutch.

3-6.9.2.3 Shear Time - This continuously variable resistor enables the operator to vary the application time of the Shear Blade. Shearing is accomplished by exerting a given amount of force for a given period of time. These factors will vary according to the ambient temperature and the composition of the tape.

3-6.9.2.4 Comb-Out Time - This continuously variable resistor enables the operator to adjust the length of time during which the comb-out operation is functioning.

* MCU = Master Control Unit

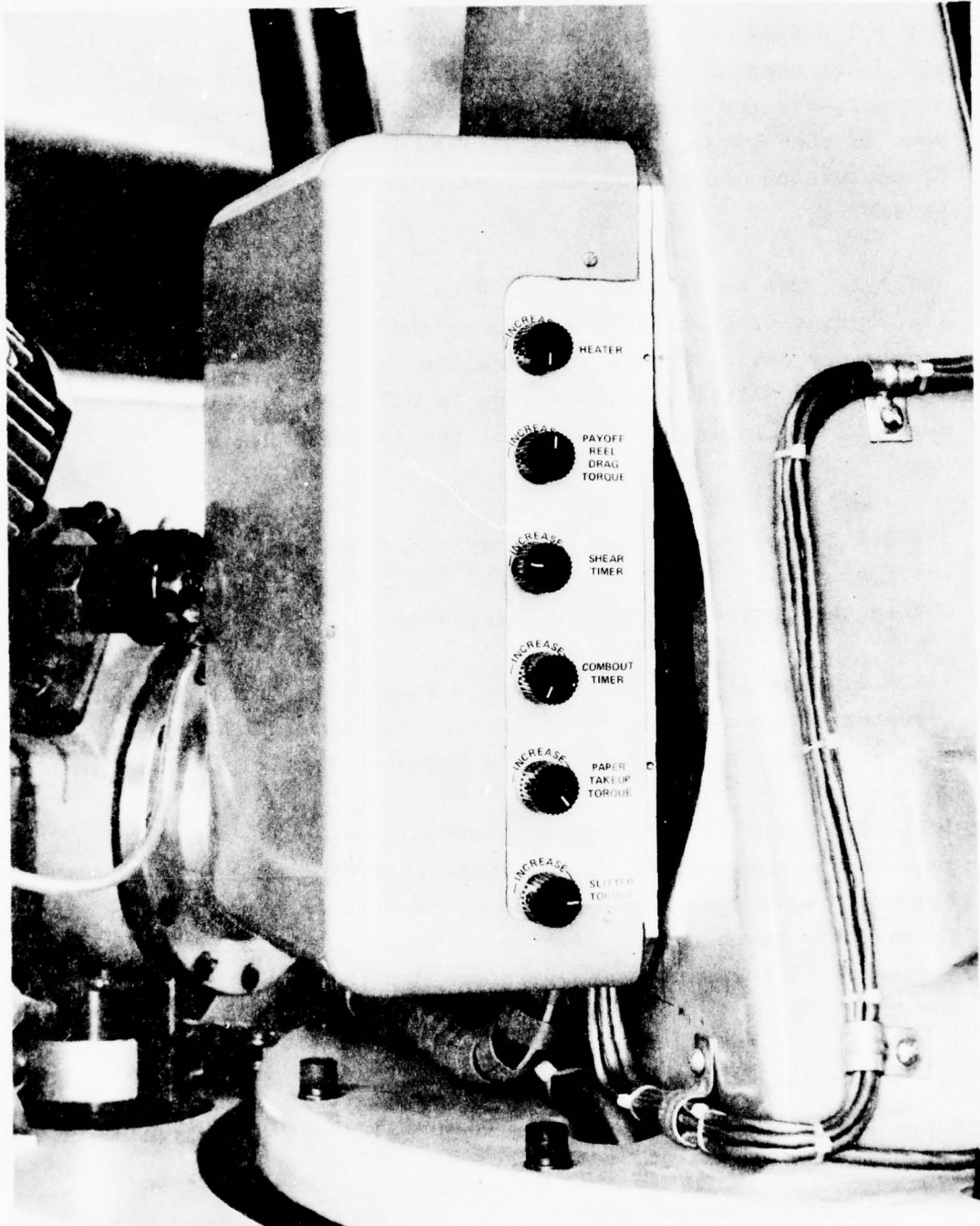

Figure 20. Tape Head Auxiliary Control Panel

3-6.9.2.5 Takeup Torque - This continuously variable resistor enables the operator to vary the amount of torque being applied to the Paper Takeup Reel by the Magnetic Particle Clutch.

3-6.9.2.6 Slitter Torque - This continuously variable resistor enables the operator to adjust the driving torque of the Slitting Rolls in accordance with the needs of the various types of tape that can be run on this machine.

3-6.9.3 The Pneumatic Control Panel (Figure 21) contains three pressure regulators, each with accompanying gauge, which control those assemblies requiring frequent adjustment due to the different types of composite tape that can be used on the ATLAS.

3-6.9.3.1 Dancer Force - This pressure regulator enables the operator to vary the air pressure supplied to the Loop Box air cylinders. The setting of the regulator is a function of the type of tape used.

3-6.9.3.2 Shear Force - This pressure regulator enables the operator to vary the air pressure supplied to the Shear Assembly actuating cylinders. The setting of the regulator is a function of the "boardiness" of the tape being used.

3-6.9.3.3 Roller Force - This pressure regulator enables the operator to vary the force applied to the Placement Roller or Placement Unit. Design parameters are such that the maximum force is 100 pounds at 32 PSIG. All other settings are directly proportional.

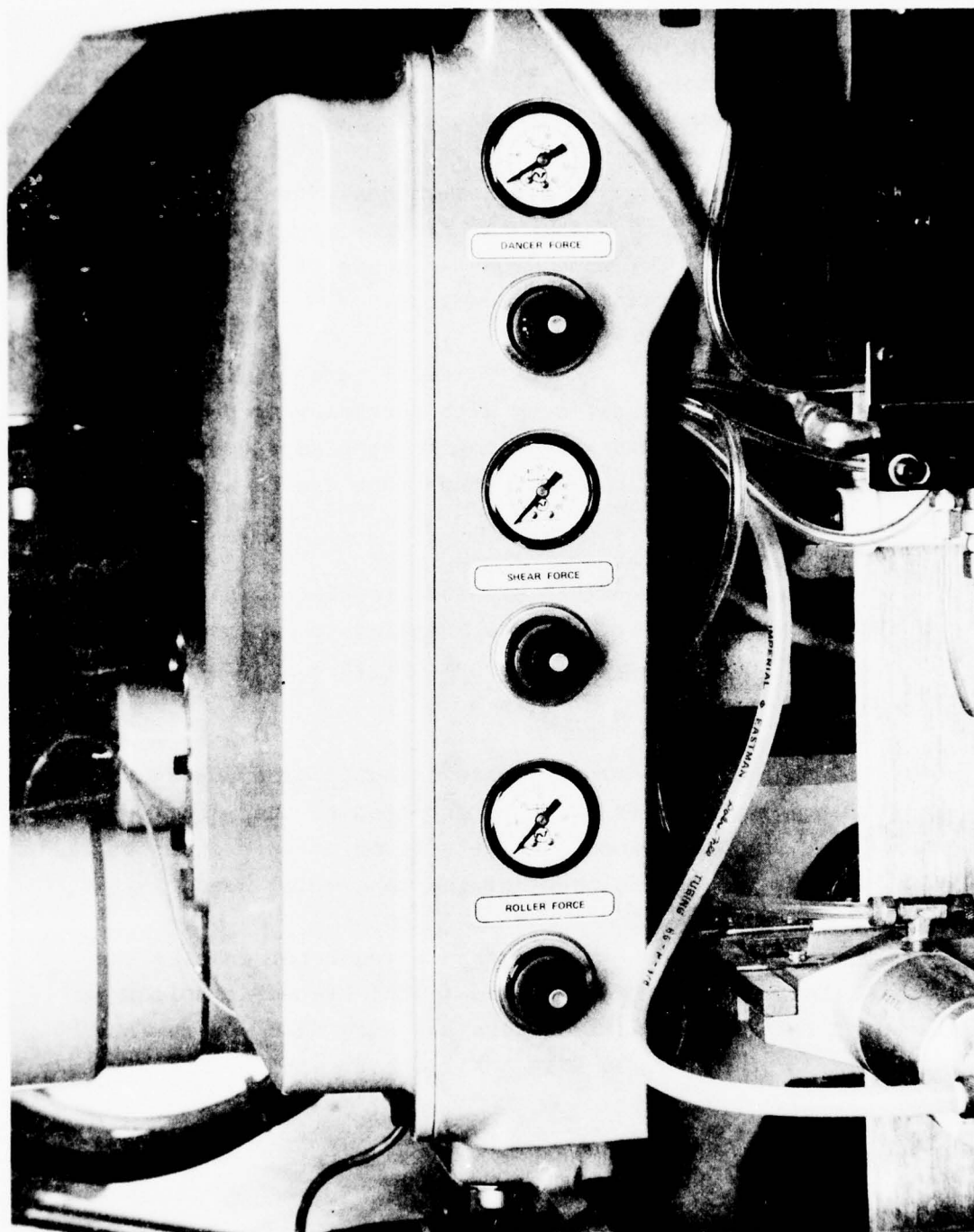

Figure 21. Tape Head Pneumatic Control Panel

3-7 Headstock and Tailstock Units

The Headstock and Tailstock Units have a number of similarities, and were designed to use a number of identical parts. The main frame, an iron casting, and the adjustable vertical slide units are common to both.

Each has a three jaw chuck to hold workpiece mandrels.

The two units are located by keys from the central keyway along the centerline of the machine base, and are clamped to the two tee slots mounted below the table surface. Figure 22 shows the headstock in position on the machine.

Elevation of the chucks from 10" centerline height above the table top to 30" height is by manually operated handle. Integral rotating indicators, in the handles, give the position of the slides.

3-7.1 The Headstock, shown in Figure 22 is a powered unit forming the "D" axis of control in the ATLAS system.

3-7.1.1 The drive and gearbox consist of a permanent magnet D.C. motor coupled to a 80:1 reduction ratio Harmonic Drive gearbox. The gearbox was constructed with a minimum of backlash to the flexible spline unit.

3-7.1.2 The feedback for the "D" axis is provided by an Inductosyn Scale unit, shown in Figure 23. The rotating scale is mounted to the output shaft of the gearbox.

3-7.1.3 The three jaw self-centering chuck mounts to an adaptor flange attached to the output shaft of the gearbox. The maximum speed of the drive is 10 rpm of the chuck.

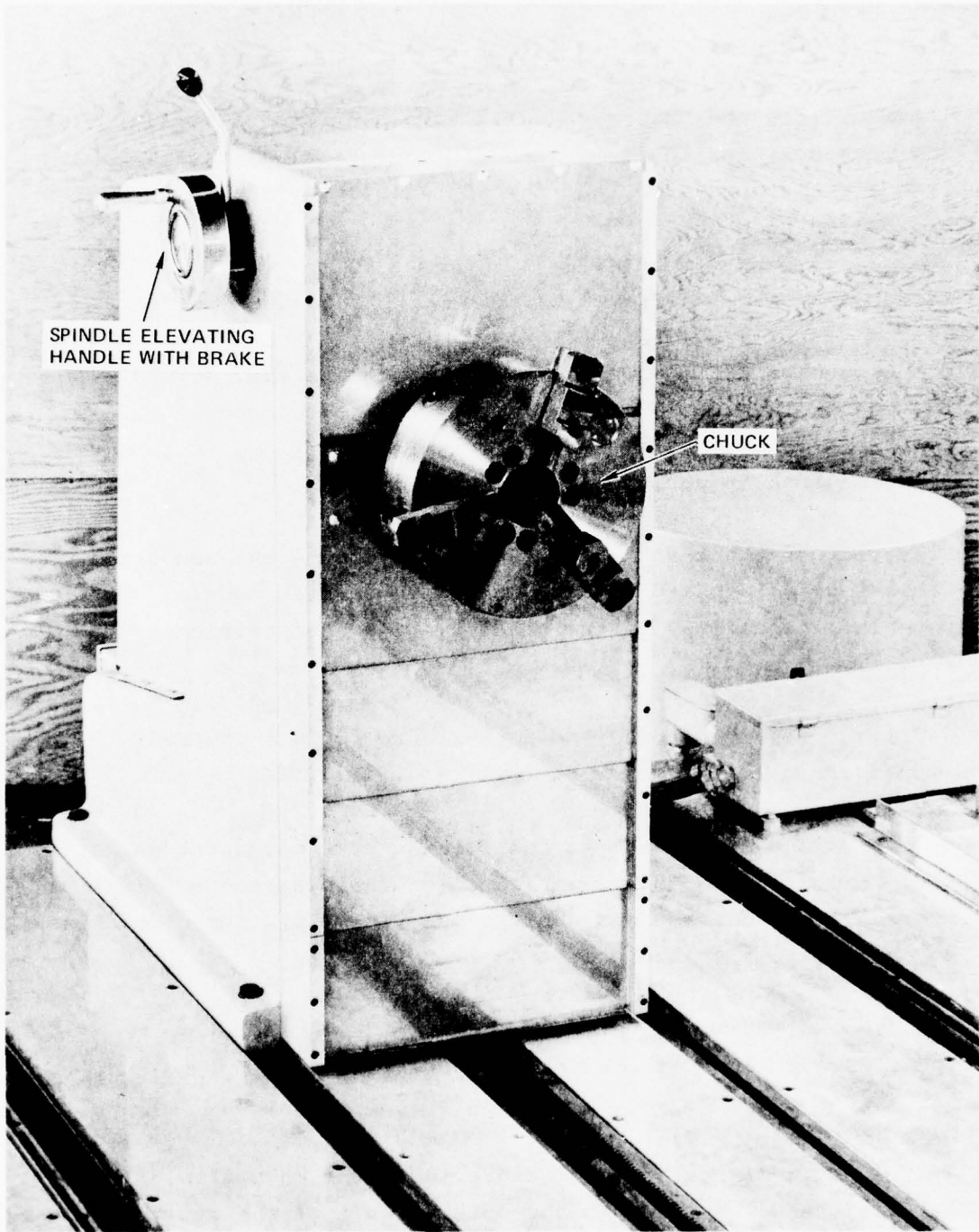

Figure 22. Headstock

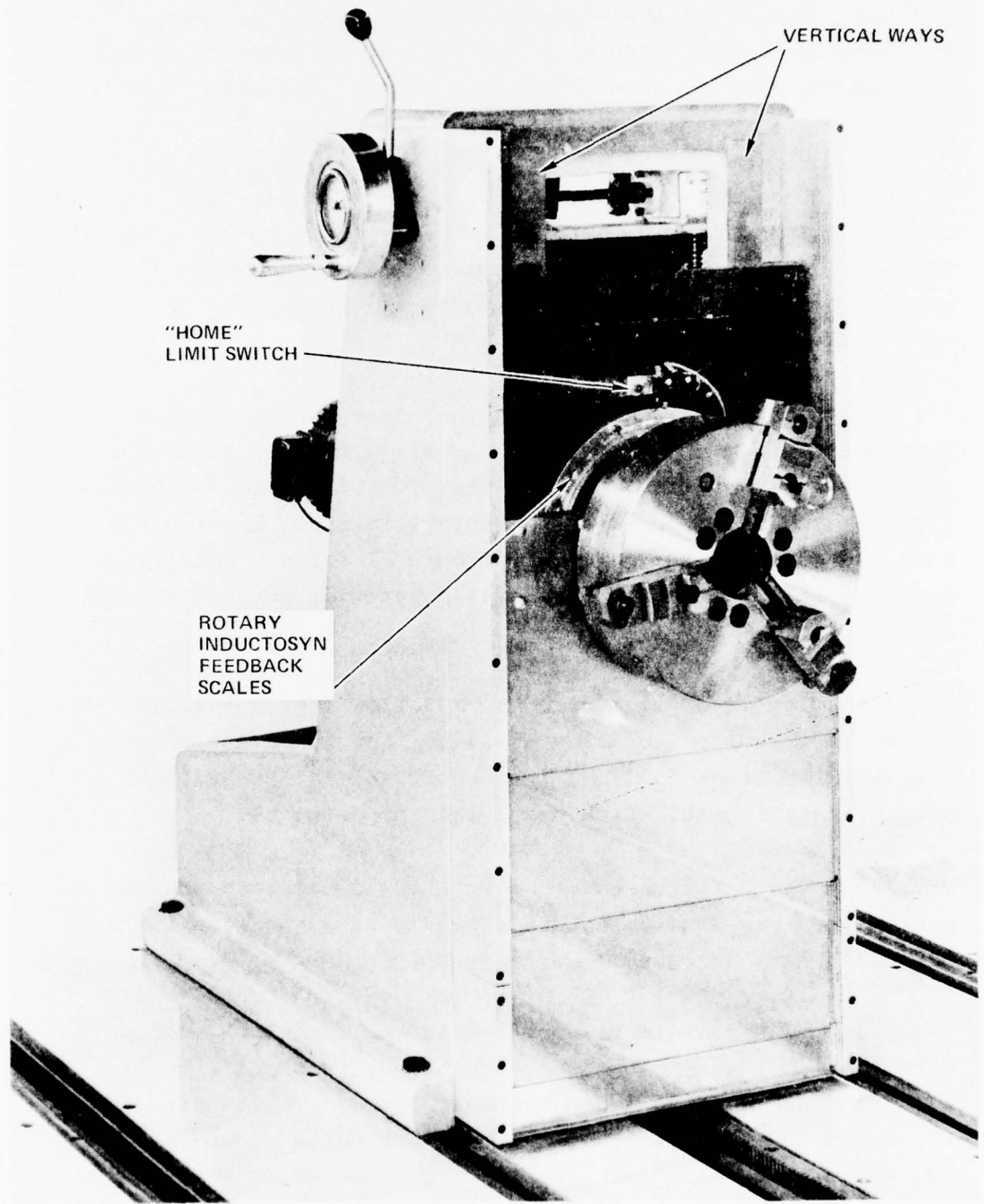

Figure 23. Vertical Ways, Headstock

3-7.1.4 The main cast iron frame of the headstock carries the vertical ways, faced with filled teflon strips to reduce sliding friction. Elevation of the sliding carriage is by a twin jack screw arrangement, shown in Figure 24.

3-7.1.5 The rear of the D.C. motor and integral tach. generator, carries a 250 line/rev. optical encoder geared to the motor shaft. This is shown in Figure 24. The output from the encoder is fed to the electronic control system used to synchronize the rotation of the Steady Rests to the "D" axis.

3-7.2 The Tailstock is shown in Figure 25. As in the Headstock unit, the vertical moving slide, guided by the anti-friction ways, has 20 inches of travel. Figure 26 shows the front of the tailstock with the covers removed, showing the ways and moving carriage unit. Figure 27 shows a rear view giving a layout of the twin elevating jack screws and the quill unit.

3-7.2.1 The chuck is mounted to a hollow freely rotating shaft. The shaft is hollow to allow a vacuum line to be fed through it for use with blade tooling. The shaft and bearings rotate within a quill unit, which has 6 inches of travel.

3-7.2.2 Drive to the quill motor is by a rack and pinion, manually driven from an external handle through a gearbox and splined shaft. Figure 28 shows the rack drive arrangement.

3-7.2.3 To assist in re-positioning the Tailstock unit at different positions along the machine base, four air cushion lift pads are mounted under the main frame. These units are regulated by the four pressure regulator units shown in Figure 29. A quick release air line fitting, mounted on the rear of the tailstock, brings air from a flexible airline to the four units.

TWIN
ELEVATING
JACK SCREWS

DC
MOTOR

ENCODER
OUTPUT FOR
STEADY REST
SYNCHRONIZATION

Figure 24. Headstock Assembly, Rear View, Cover Removed

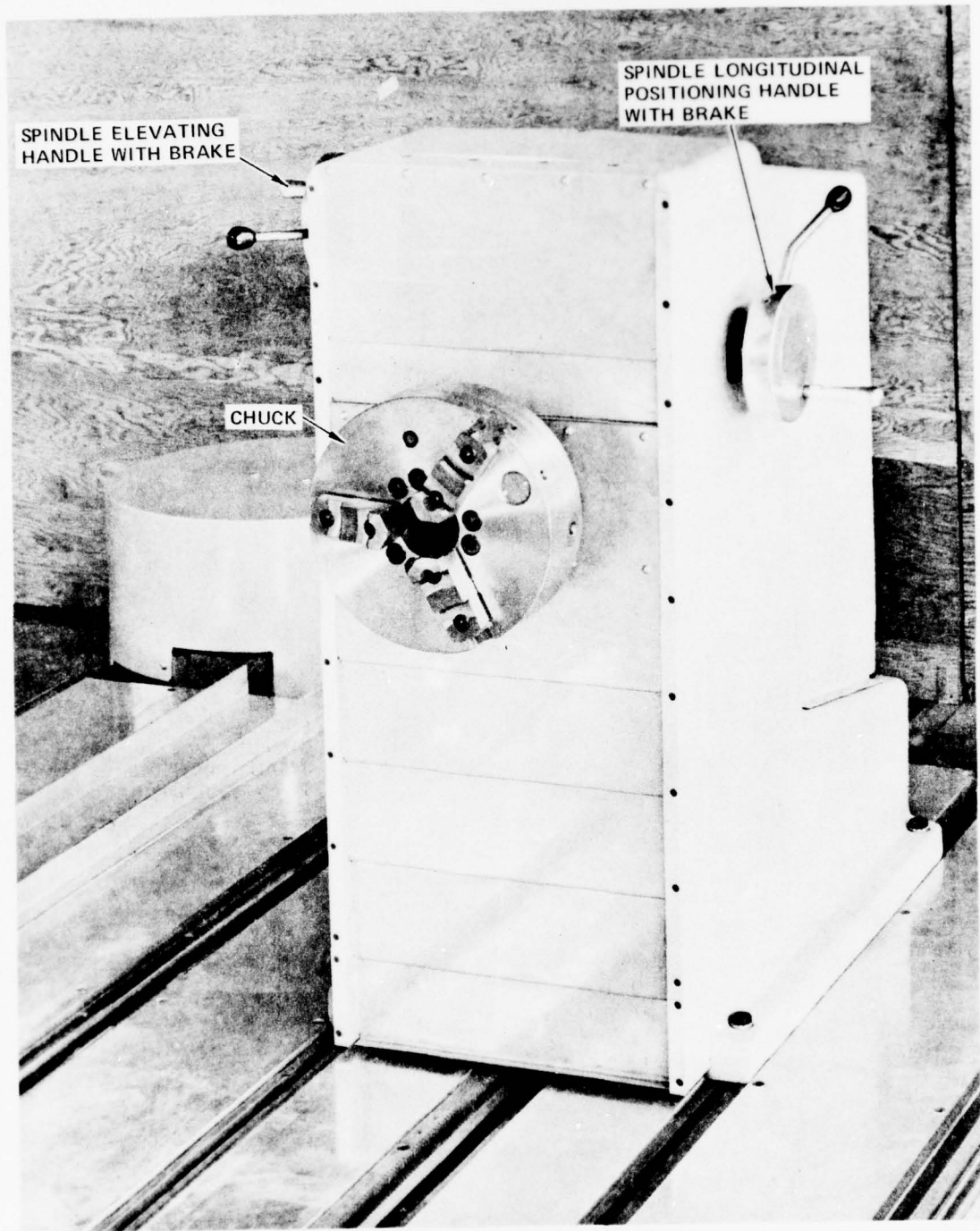

SPINDLE ELEVATING
HANDLE WITH BRAKE

SPINDLE LONGITUDINAL
POSITIONING HANDLE
WITH BRAKE

CHUCK

Figure 25. Tailstock

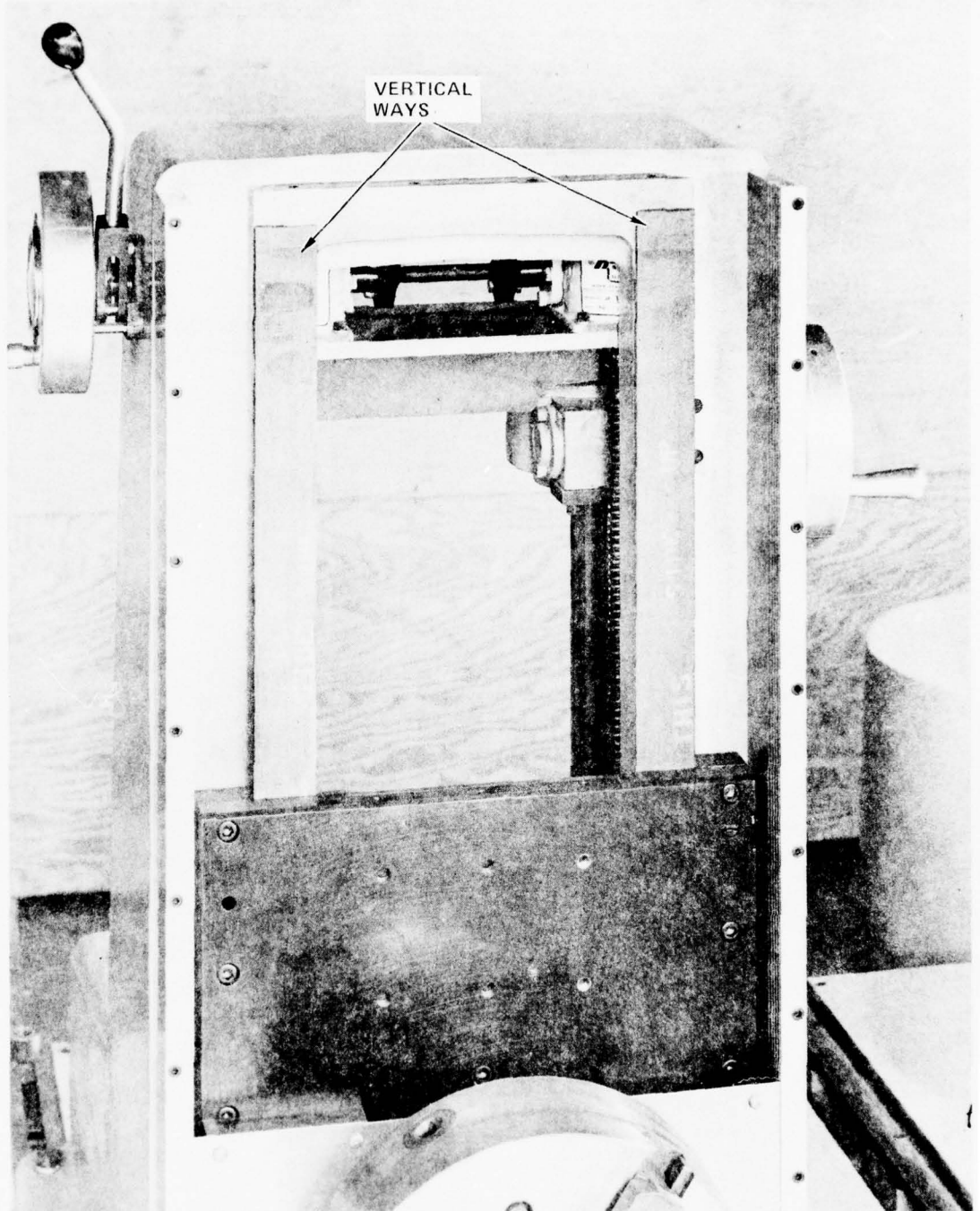

Figure 26. Vertical Ways, Tailstock

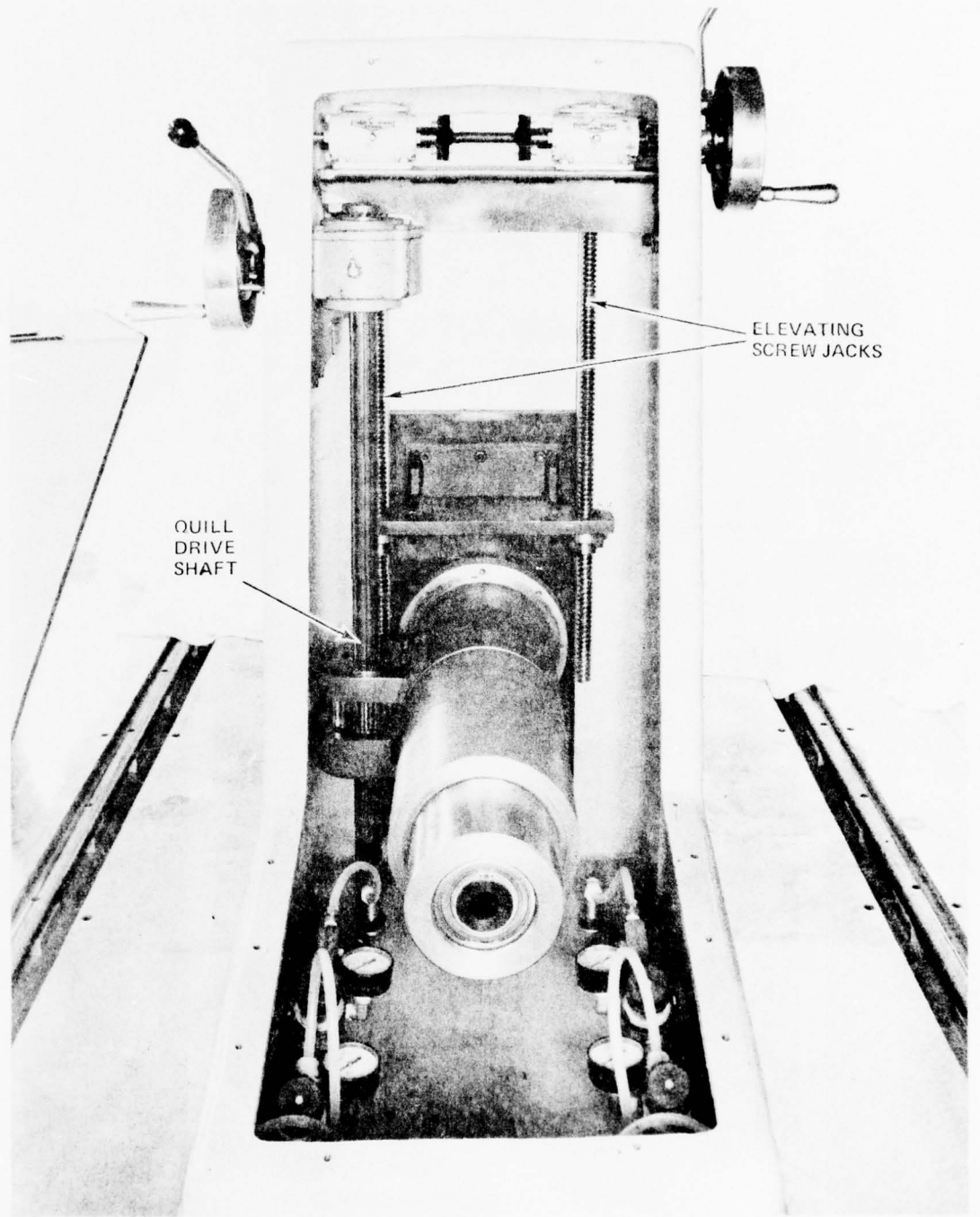

Figure 27. Tailstock Assembly, Rear View, Cover Removed

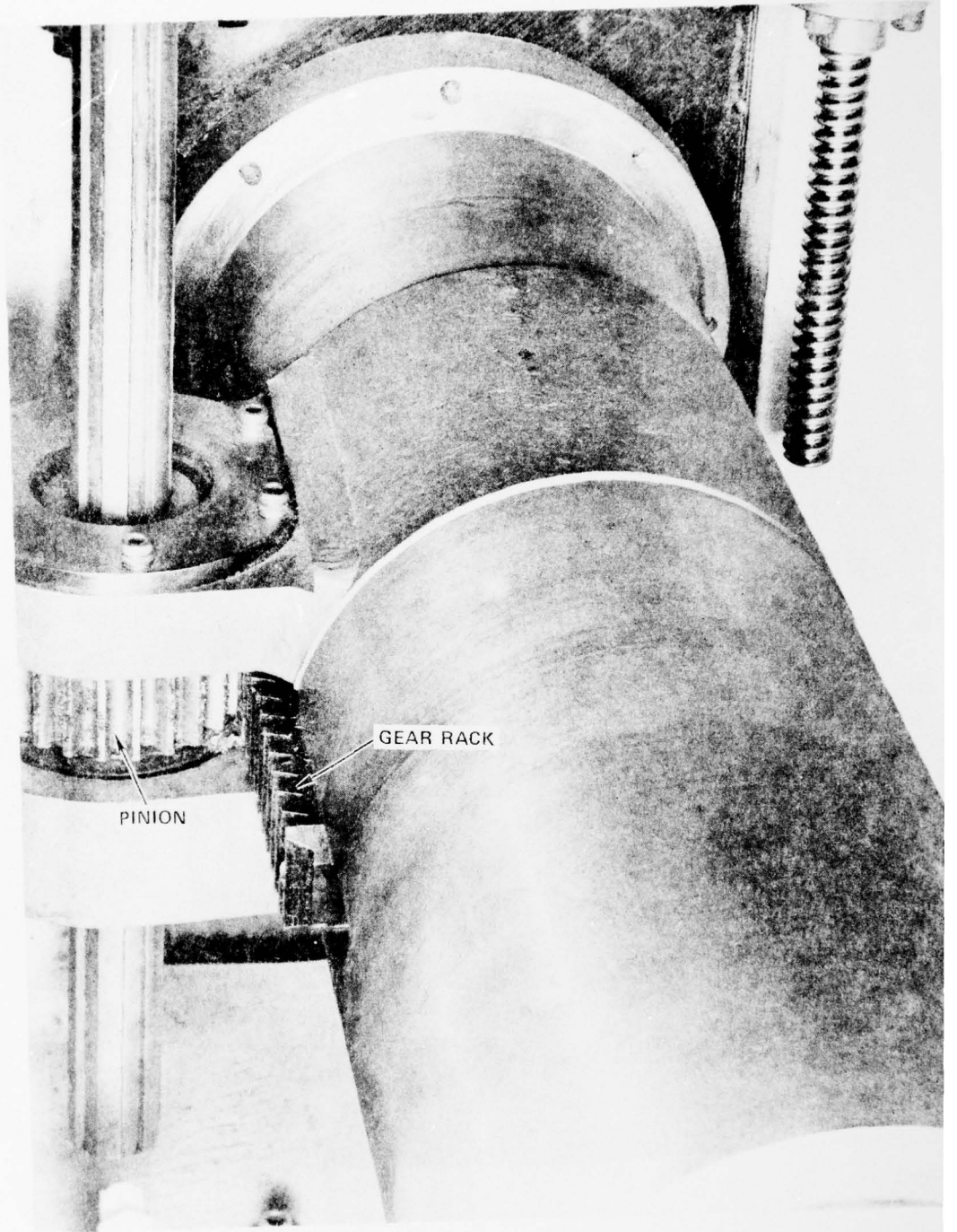

Figure 28. Quill Drive, Tailstock

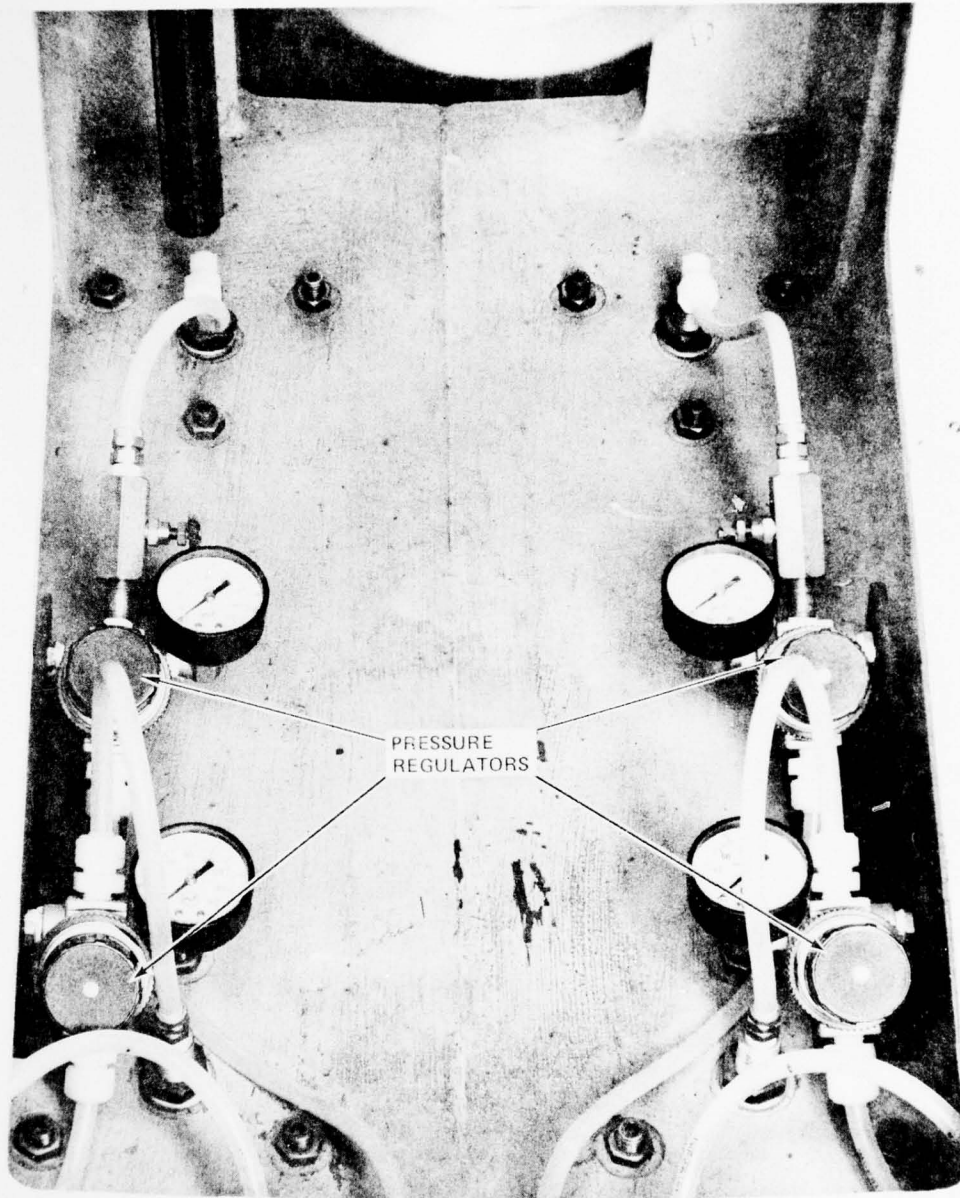

Figure 29. Tailstock Air Cushion Controls

Design of the Steady Rests was done during the Contract covered by this report. The Steady Rests were designed to meet the requirements of the helicopter blade spar tooling being fabricated by Boeing-Vertol Company.

The specific tooling support requirement for the Steady Rests requires rotational as well as linear control of the units.

3-8.1 The tooling consists of an aluminum mandrel, with shafts at each end corresponding to the pitch axis of the blade. The mandrel is a D shape for most of its length. Along the D shape section a strongback is fitted. The strongback carries locating ways to be supported by the Steady Rest units. Figure 30 shows a diagrammatic layout of the tooling together with the Headstock, Tailstock and two Steady Rests.

3-8.1.1 Layup of torsional plies in the strongback D section only takes place from one side to the other, with a wrapping motion over the leading edge. In the root-end section the torsional plies require a continuous wrapping motion for 2-1/2 revolutions of the tool.

3-8.1.2 Supporting rollers, mounted inside the Steady Rest Rings, are located on the strongback ways to give support to the tool. When a Steady Rest unit moves to a parking position, clear of the tool, the supporting rollers disengage from the strongback ways. Rotational synchronization is maintained, so that they re-engage when the Steady Rest moves back to support the tool again.

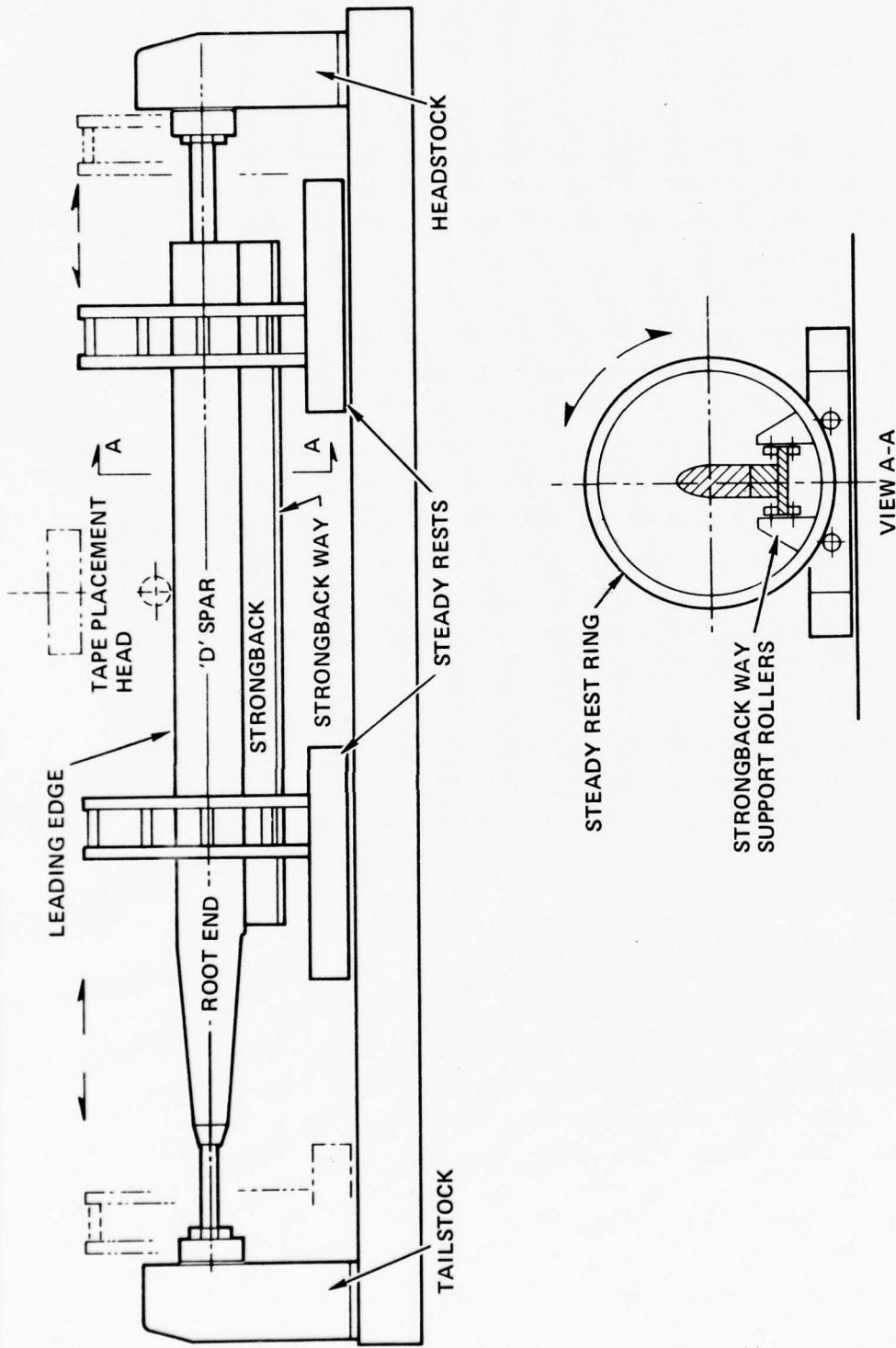

Figure 30. Spar Tooling and Steady Rest Arrangement

3-8.1.3 The shafts from the pitch axis of the tool engage in the chucks of the Headstock and Tailstock. The rotary motion of the Steady Rests is synchronized with the "D" axis at all times.

3-8.1.4 The linear movements of the Steady Rests are controlled from the relative position of the gantry. A Steady Rest is positioned either side of the tape placement head, so that at least one unit is giving support to the strongback at all times.

3-8.2 The Steady Rest shown in Figure 31 is positioned at the Tailstock end of the ATLAS machine.

3-8.2.1 The base frame is a steel weldment and has a set of anti-friction rollers which locate it on the hardened circular ways set into the base of the machine. Four heavy duty cam rollers, mounted on the base frame, support the weight of the ring assembly.

3-8.2.2 Two adjustable and removeable support frames carry sets of cam follower rollers to give added support to the rotating ring.

3-8.2.3 The drive is by a D.C. motor to a dual output gearbox, via two toothed timing belts. The two output pinions from the gearbox mesh with the 50 inch pitch diameter ring gear. Anti-backlash through the gearbox is achieved by rotating the two toothed timing pulleys, on the motor side, relative to one another, thus creating opposite pre-load in the timing belts and spur gearing.

3-8.2.4 Rotational feedback is by a tach. generator and digital encoder unit mounted on the end of the D.C. drive motor.

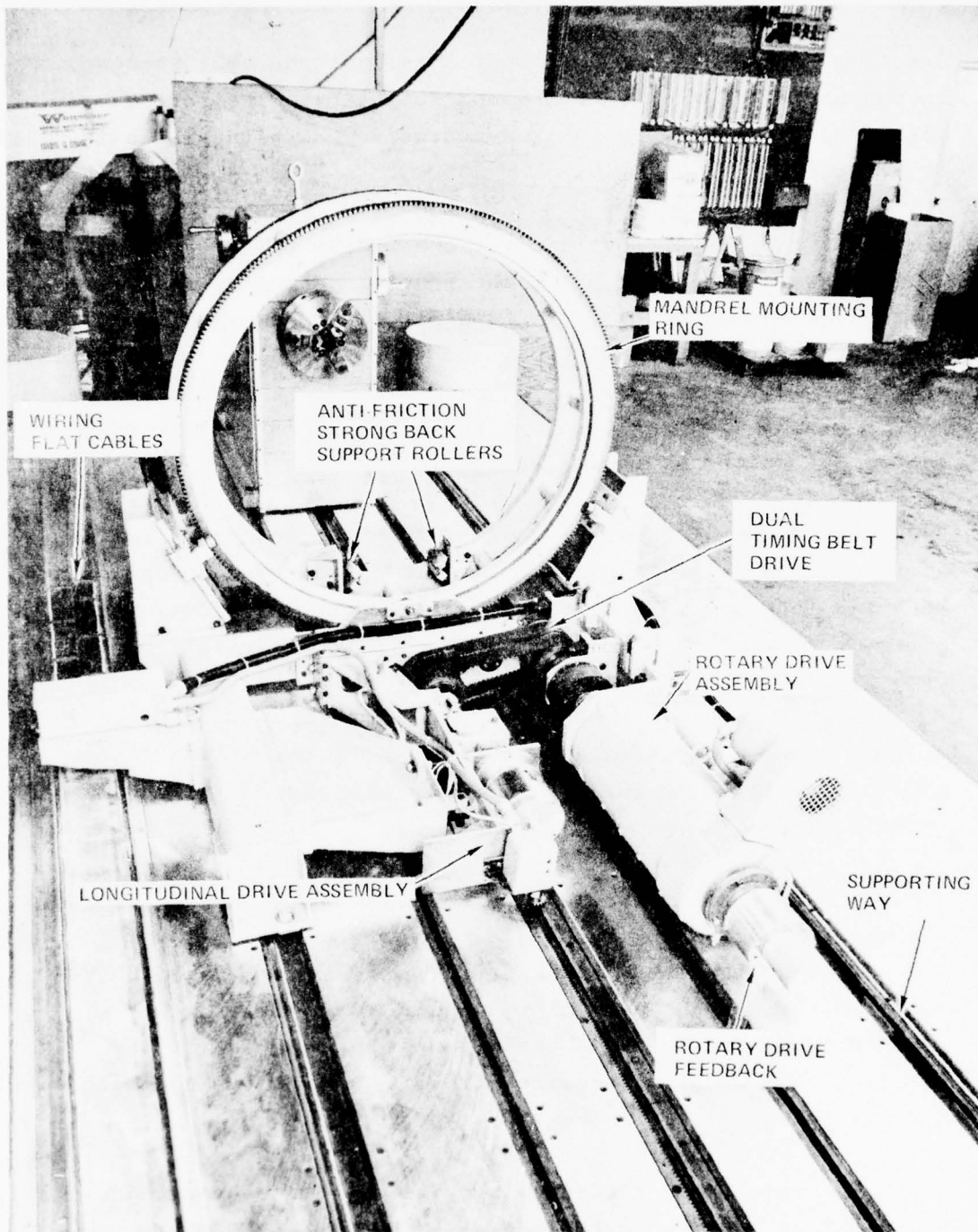

Figure 31. Steady Rest Assembly

3-8.2.5 The ring assembly, with ring gear, carries the anti-friction supporting rollers which engage with the strongback ways on the spar tooling.

3-8.2.6 Linear motion is provided by a 3/4 H.P.D.C. motor driving through a worm reduction gearbox to a spur gear meshing with lengths of gear rack located along the center groove of the base of the machine.

3-8.2.7 Analogue position feedback is used to sense linear motion. A 10 turn potentiometer unit is driven from the gear rack with two trimming potentiometers varying the characteristics, to provide adjustable motion control of the Steady Rests along the machine bed.

3-8.2.8 All the control and power wiring to the Steady Rests, which have 40 ft. travel, is brought to them by flat section, 12 conductor cables, attached to 6 inch wide stainless steel strips. Teflon sheet coating on the back of the strips provides less sliding friction between the moving and stationary surfaces.

3-9 CONTROLS

During the preceding design contract for the ATLAS machine, the requirements for the numerical control system were established. Discussions at that time with three manufacturers of numerical control equipment, Bendix Corp., General Electric and Allen-Bradley, established the type of controls currently available.

The control requirements for six simultaneous axes motions, as well as the self-programming or digitizing capability, were only available as one package in a "soft-wired" control.

The control system chosen capable of meeting these requirements was the Allen-Bradley 7300.

This section covers a description of the Numerical Control System together with the associated Drives for the axes motions.

Information relating to Data Preparation for the Control are covered in the Programming Section 5-5.

3-9.1 The Allen-Bradley 7300 control is shown in Figure 32. The unit is self contained and housed in a two bay free standing cabinet. Hinged, electrically interlocked doors provide complete access to the inside at the front and rear. Figure 33 shows the units inside the Control.

3-9.1.1 The Hewlett-Packard computer, containing 24K of memory core, is a complete slide-out unit. Illuminated push buttons on its front surface enable manual set-up and input to the computer, as well as visual indication of the contents of any selected memory location.

3-9.1.2 The interface modules are the "hard-wired" portion of the control. They form the link between the incoming feedback signals to the computer and the interface of the outputs to the drives.

3-9.1.3 The CRT display has a 1000 character capability. Information displayed on it is divided into three basic areas.

3-9.1.3.1 The upper section, of four lines, is used for display of information entered by the manual keyboard (MDI).

3-9.1.3.2 The middle section displays the readouts of the axes positions and feedrate settings.

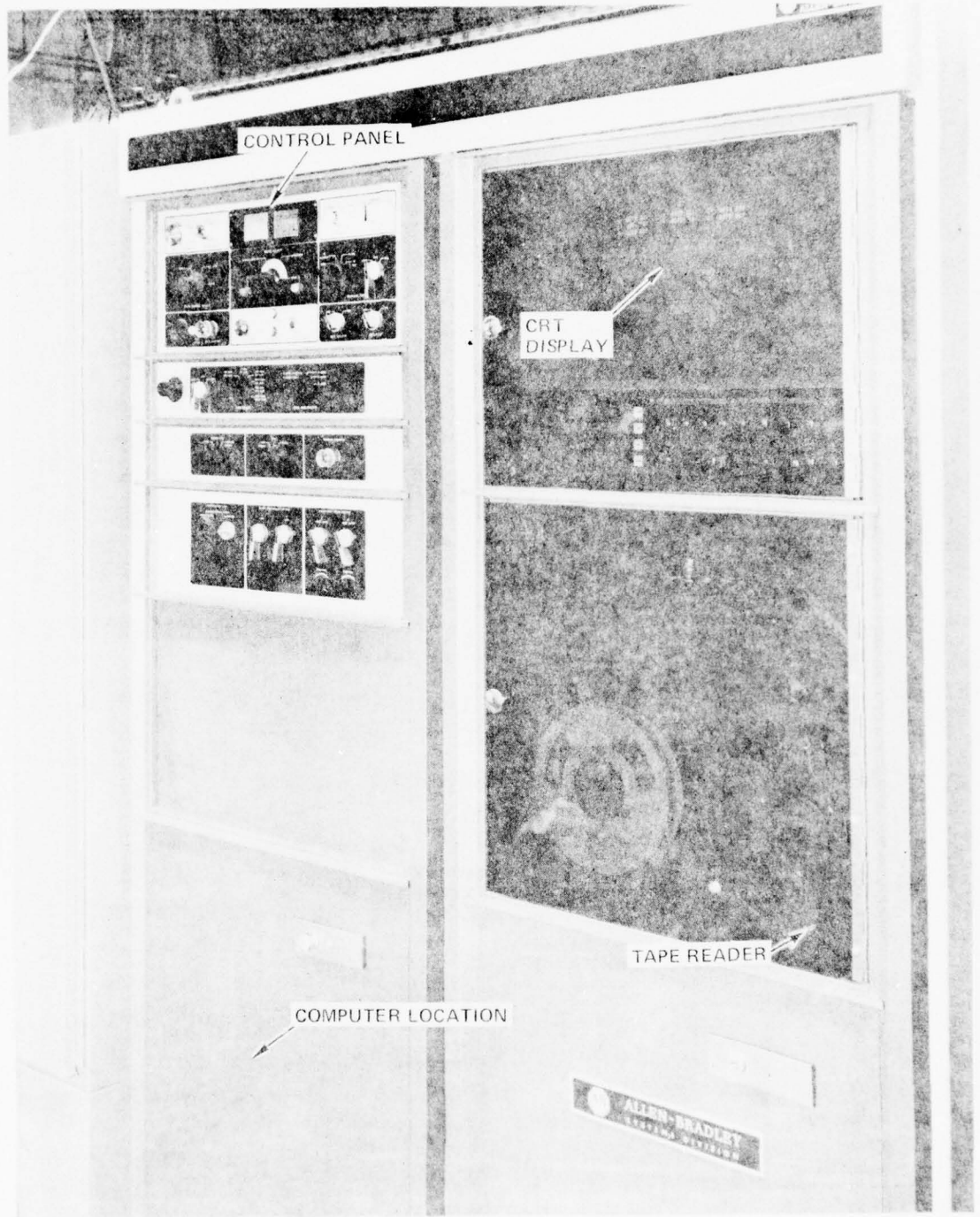

Figure 32. Numerical Control Console

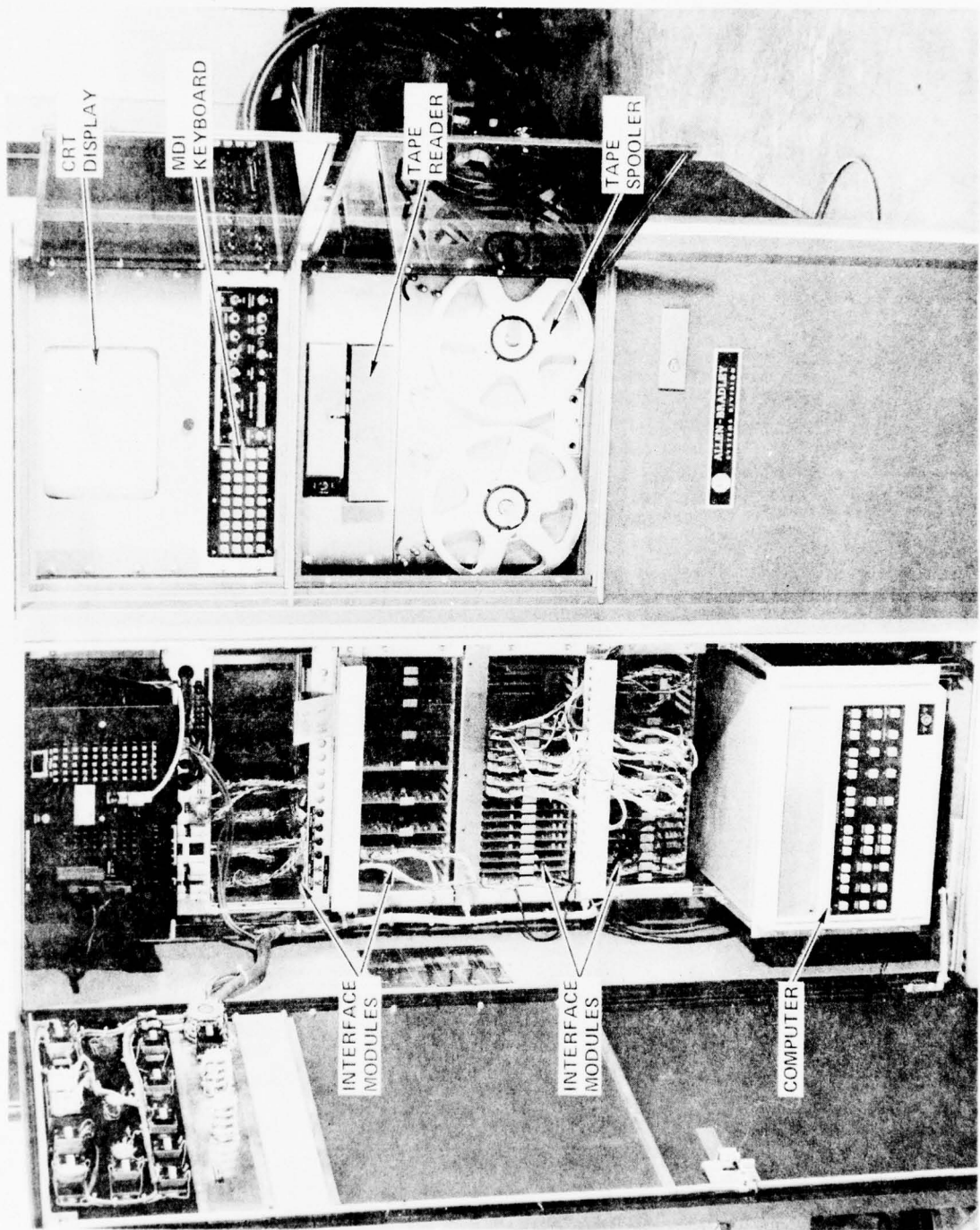

Figure 33. Inside of the Control

3-9.1.3.3 The lower half is used to display the information being read from the tape reader. Eight blocks of information are read at a time, and displayed. An asterisk indicates the "active" block of information.

During digitizing the blocks of information are displayed in the lower half, prior to being transferred to the tape punch and teletypewriter.

3-9.1.4 The Manual Data Insert (MDI) keyboard is used to enter information to the control manually.

Completely programmed moves may be entered by this keyboard and displayed on the CRT.

The keyboard is also used for creating additional information for transferring to the tape punch and teletypewriter during a digitizing operation.

3-9.1.5 The tape reader is a photo-optic device using a single light source.

3-9.1.6 The tape spooler has a capability of taking 19-1/2 inch diameter spools.

3-9.2 7300 Control Panels

The following are the functions of the Control Panels on the 7300 system.

3-9.2.1 The Main Control Panel - Figure 34 provides those control devices most frequently used for operation of the basic system.

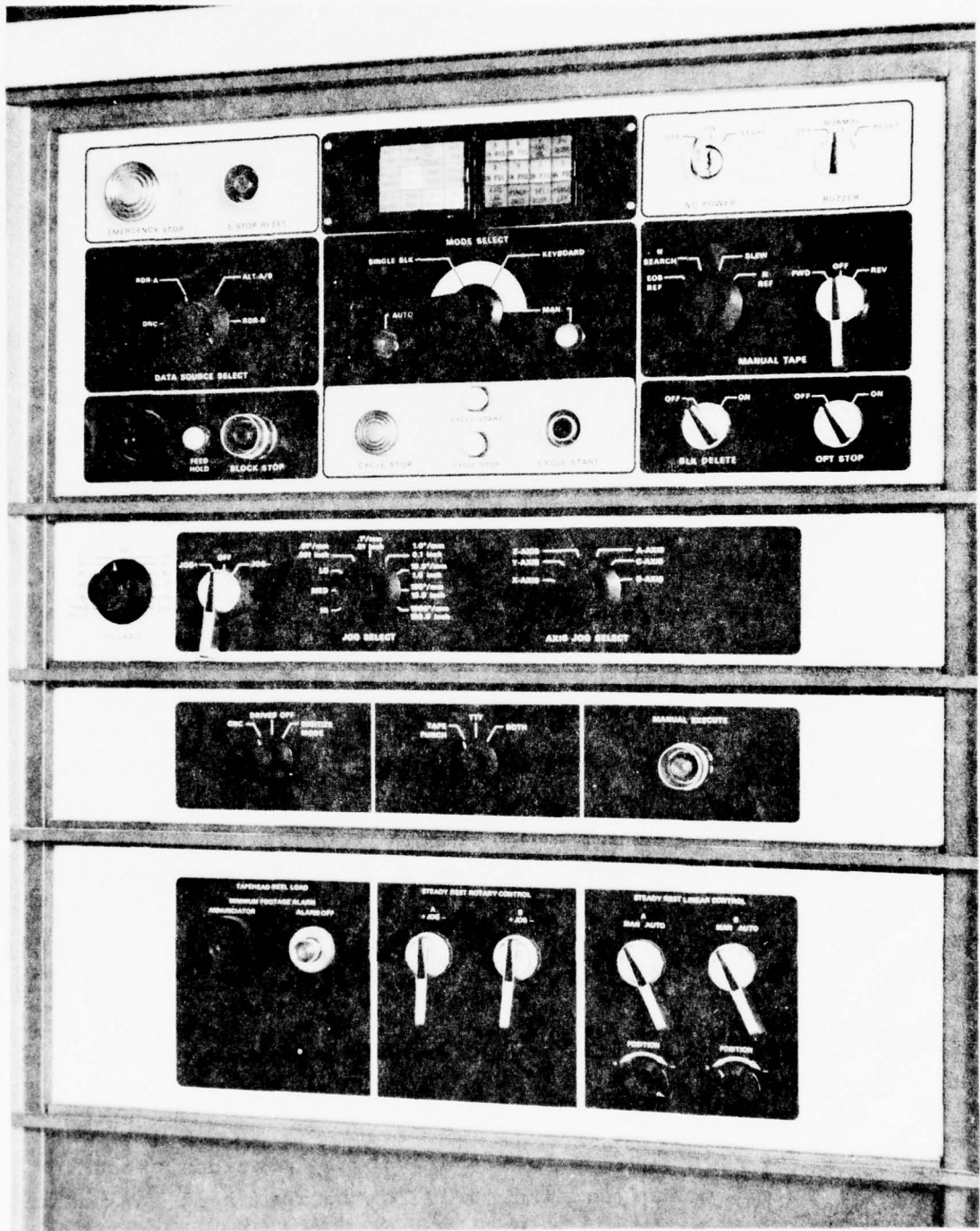

Figure 34. Main Control Panel

3-9.2.1.11 OPT STOP - A two position device to discriminate against an MØ1 code. In the OFF position, the MØ1 code is ignored. In the ON position, the MØ1 code will cause the Numerical Control Unit to come to an orderly, programmed stop as evidenced by the illumination of the red PROG STOP annunciator.

3-9.2.1.12 CYCLE START - A non-annunciating and guarded momentary-on device to enable operator to initiate a cycle or restart an interrupted one.

3-9.2.1.13 CYCLE STOP - A red, mushroom head momentary-on device to enable operator to temporarily halt a cycle when the system is in AUTO mode.

3-9.2.1.14 INDICATORS - A group of 24 annunciators used to signal the status of given system functions. These indicators are detailed in Table 3 and illustrated in Figure 35.

3-9.2.2 The Secondary Control Panel - Figure 36 pictures those control devices less frequently used for operation of the basic system.

3-9.2.2.1 MACH ZERO - A toggle switch and an accompanying red annunciator provided to enable operator to return any or all of the axes to a predetermined "home" position by using the "JOG" switches on the Machine Tool Panel. When the MACH ZERO switch is in the ON position, the adjacent red annunciator will be illuminated, and if the MODE SELECT switch is in the MAN position, the various axes will seek a predetermined Zero position when selected by the AXIS JOG SELECT switch and activated by the "JOG EXECUTE" switch. Only one axis at a time may be zeroed and, when selected, will return to its home limit switch and synchronize with its true "home" position.

3-9.2.2.2 SET ZERO - A momentary-on device to enable operator to establish a zero position at any point along any axis.

TABLE 3.

Annunciators

Left Panel reading from left to right and from top to bottom		
Annunciator	Color	Meaning
MCU TEMP	Red	Control Overtemperature
OVER TRAVEL	Red	Axis Overtravel
RDR NOT READY	Red	Tape Reader Not Ready
EXCESS ERROR	Red	Excess Servo Error
PROG END	Red	MØ2 or M3Ø Decoded - Program End
PROG STOP	Red	MØØ or MØ1 Decoded - Program Stop
READ ERROR	Red	Tape Reader Error/Tape Error
SIGN REV	Amber	Any Axis Sign Reversed
CONTR MODE	Green	Contour Mode
ABS MODE	Green	Absolute Programming

Right Panel reading from left to right and from top to bottom		
Annunciator	Color	Meaning
A IN POS	Green	"A" Axis In Position
D IN POS	Green	"D" Axis In Position
A RDR ON	Amber	"A" Tape Reader Is ON
DIG MODE	Green	Digitizer Control
Y IN POS	Green	"Y" Axis In Position
X IN POS	Green	"X" Axis In Position
Z IN POS	Green	"Z" Axis In Position
C IN POS	Green	"C" Axis In Position
AXIS LAG LIMIT	Red	Feed Rate Suppressor Activated
PUNCH BUSY	Green	Tape Punch Cannot Accept Data
TTY BUSY	Green	Teletypewriter Cannot Accept Data
PUNCH LAG	Red	Tape Punch Lagging Machine

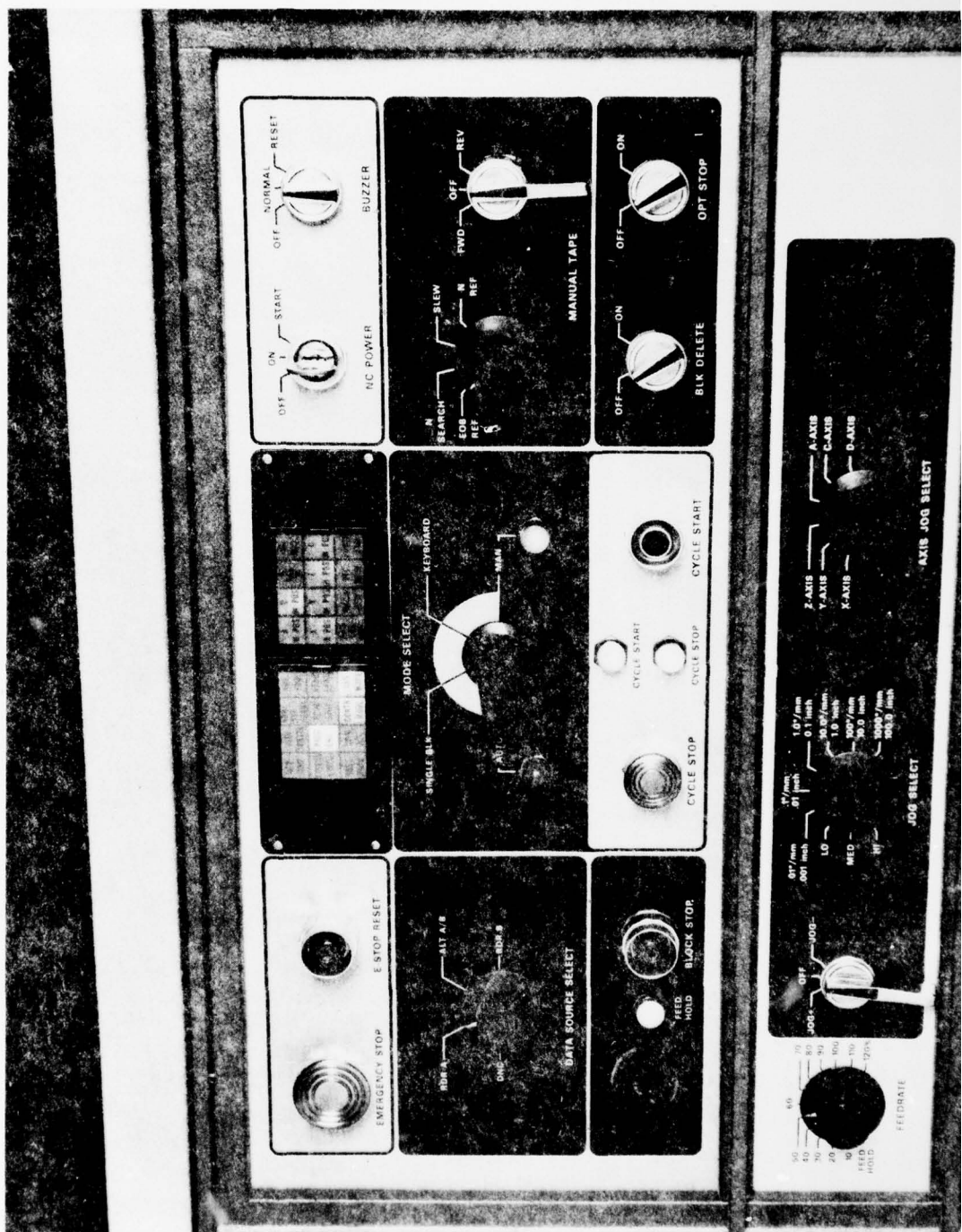

ON START

OFF NORMAL RESET

NC POWER

BUZZER

SEARCH

EOB REF

REF

SLW

N

FWD

OFF

REV

MANUAL TAPE

OFF ON

BLK DELETE

OFF ON

OPT STOP

EMERGENCY STOP

E STOP RESET

MODE SELECT

KEYBOARD

SINGLE BLK

ABT

MM

CYCLE STOP

CYCLE START

CYCLE STOP

CYCLE START

CYCLE STOP

CYCLE START

DATA SOURCE SELECT

RDR A

ALT A/B

ONE

RDR B

FEED HOLD

BLOCK STOP

FEEDRATE

50 60 70 80 90 100 110 120 130 140 150 160 170 180 190 200

FEED HOLD

OFF

JOG

JOG

LD

MED

HF

0.1 inch

1.0 inch

10.0 inch

100.0 inch

1000.0 inch

10000.0 inch

1.01/min

10.01/min

100.01/min

1000.01/min

10000.01/min

Z-AXIS

Y-AXIS

X-AXIS

A-AXIS

C-AXIS

D-AXIS

JOG SELECT

AXIS JOG SELECT

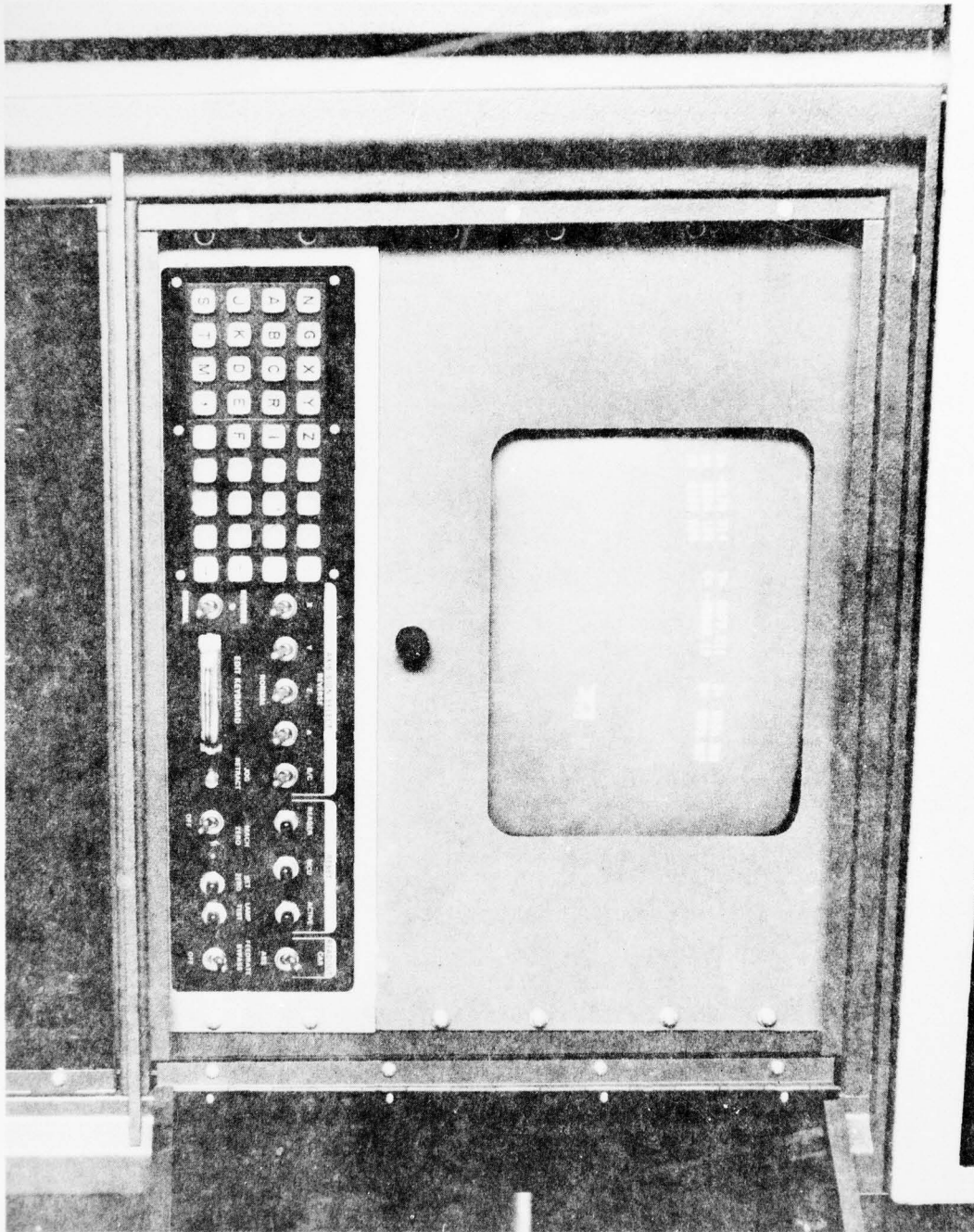

Figure 36. Secondary Control Panel

When a Zero position other than "home" is desired, the SET ZERO push button is used to transmit its coordinate(s) to the computer by either of the following methods:

- a. Set MODE SELECT switch to KEYBOARD position and input desired data with MDI Keyboard. Select appropriate axis on AXIS JOG SELECT switch and switch MODE SELECT to MAN position before depressing SET ZERO push button.
- b. Depress CYCLE STOP push button and switch MODE SELECT to MAN. Select appropriate axis on AXIS JOG SELECT switch and depress SET ZERO push button. To continue programmed path, switch MODE SELECT to AUTO and depress CYCLE START push button.

3-9.2.2.3 LAMP TEST - A momentary-on device to cause the computer to run through a systematic check of all the annunciators on all control panels to verify circuit operation.

3-9.2.2.4 FEEDRATE BYPASS - A toggle switch to enable the NCU to ignore all feedrate codes, forcing it into a rapid traverse for faster cycling of test tapes and program checkouts.

3-9.2.2.5 READOUT - A two position selector which gives the operator the option of monitoring the positions of the axes relative to a given offset (CAR position) or a display of the ABSOLUTE position including all offsets (ABS position).

3-9.2.2.6 RESET - A group of three momentary-on devices enabling operator to:

- a. Clear data from ACTIVE storage.

- b. Clear the MCU (Master Control Unit) to a start-up condition.
- c. Clear the tape READER in the event of a programming error.

When the system is in a Cycle Stop condition, all data may be cleared from the current Active storage block by depressing the ACTIVE Reset push button. Whenever all data is to be cleared so a new program can be started, the MCU Reset push button is depressed which clears the control to a start-up condition only if an Emergency Stop mode or an ECB condition exists. If the tape reader malfunctions due to a programming error which does not cause a shutdown to occur, the operator may clear the reader by depressing the READER Reset push button.

3-9.2.2.7 AXIS SIGN SELECT - A group of six 2-position selectors, one for each axis, to enable operator to perform mirror runs on the same tape. The amber SIGN REV annunciator on the sub-panel will illuminate if one or more of these switches is in the REVERSE position.

3-9.2.2.8 JOG RETRACT - A clear annunciating push button that enables the operator to Jog any selected axis away from its point of contact with the work piece after first having depressed the CYCLE STOP push button with the system in the Automatic mode. The selected axis will continue to move for so long as the JOG RETRACT push button is held depressed. Depressing the CYCLE START push button causes the retracted axis to return to the last programmed point before retraction and to continue its programmed path.

3.9.2.2.9 The MDI (Manual Data Insert) Keyboard, consisting of 36 characters, provides the means of manually entering data into the computer to supplement that which is programmed on tape. The MDI information is immediately displayed on the first four lines of the CRT to permit operator verification and/or modification before the data is transferred to the computer. The MDI keyboard consists of 36 keys arranged as follows:

- a. The following alpha characters:
A thru G, I, J, K, M, N, R, S, T, X, Y and Z
- b. Numerics 0 thru 9
- c. Arithmetic plus (+) and minus (-) signs
- d. A comma (,) and a space (SPACE) key
- e. A transmit (XMIT) key for transferring data to the computer
- f. A carriage Return (CR) key for inputting an EOB code (#)
- g. A left cursor or back space (←) key
- h. A right cursor or forward space (→) key

To repeat a character, hold the appropriate key depressed until the desired number of repetitions have been made. All data must be prefixed with a type code before being transmitted to the computer. Examples of these codes are listed below:

Manual Data Input	MI
Sequence Search	NS
Tool Length Offset	TC
Fixture Offset	FA
Cutter Compensation	CC
Block Edit	BE

3-9.2.1.1 NC POWER - A spring loaded, keylocked device for applying AC power to the NCU and for actuating a contactor to enable the MCC drive solenoids, provided the Main Disconnect for the MCC has been closed.

3-9.2.1.2 BUZZER - A computer activated audible alarm device to signal an emergency shutdown or any other condition requiring immediate operator action.

3-9.2.1.3 BUZZER SELECTOR - A spring loaded, three position device to acknowledge an alarm condition and to disable the Buzzer and reset the buzzer circuitry. In the OFF position, the NCU will be forced into a Feed Hold condition as evidenced by the illumination of the FEED HOLD annunciator.

3-9.2.1.4 EMERGENCY STOP - A red, mushroom head momentary-on device which, when depressed, de-energizes all drive contactors and causes all brakes to be applied, bringing the Tape Layup Machine to an abrupt halt.

3-9.2.1.5 E-STOP RESET - A red annunciating and guarded momentary-on device to de-energize and "safe" the Emergency Stop relay and to restore the system to an operational condition.

3-9.2.1.6 DATA SOURCE SELECT - A four position rotary device to enable operator to select the desired data source for use as a computer input, as applied to the ATLAS, the switch must always be at the Reader A position.

3-9.2.1.7 MODE SELECT- A four position rotary device to enable operator to select the desired mode of operation. Selecting the AUTO position of the MODE SELECT switch causes the control to operate in a continuously cycling mode, reading and executing data in accordance with its programmed instructions. Selecting

this mode will cause the green annunciator below and to the left of the selector knob to illuminate. Selecting the SINGLE BLK position causes information in the next accessible buffer area to be transferred to ACTIVE and executed. If no data is present in buffer storage, selecting this mode will cause reader to read 8 blocks of data into the buffer and to execute one block. In the KEYBOARD position, the Manual Data Insert keyboard is enabled to allow the operator to manually input data into a buffer storage area and to execute it. The MAN position is used for any operation requiring motion of the axes, other than from tape or from keyboard command, such as JOG or MACH ZERO. Selection of this mode will cause the blue annunciator below and to the right of the selector knob to illuminate.

3-9.2.1.8 MANUAL TYPE - Two control devices combine to enable operator to select the type of tape search desired and the direction of the tape travel.

- a. "Search Mode Selector" - A four position rotary device to enable operator to select the desired search mode.
- b. "Tape Direction Selector" - A three position, spring return-to-center device to enable operator to select the desired search direction and to activate the capstan drive. In the EOB REF position of the "Search Mode Selector", the reader will move one block in the direction selected by the "Tape Direction Selector" which must be turned to the desired direction and released when the MODE SELECT switch is in the MAN position. In the N SEARCH mode, which can be enabled only when the MODE SELECT switch is in the KEYBOARD position and is activated by the CYCLE START push button, the computer chooses the direction of search after being told what number to look for by the Manual Data Insert (MDI) Keyboard. The computer assumes that the desired number is in the forward direction and will always read forward to the next number on the tape. At

this point, the computer compares the N number on the tape with the desired N number and decides by the magnitude of the number whether to continue in the forward direction or to reverse. Whenever the reader cannot find the exact block called for, an "N NOT ON TAPE" message will be displayed on the CRT. If, when searching forward, an MØ2 or M3Ø code is encountered or, when searching reverse, an EOR (EIA) or a % (ASCII) code is encountered, the search operation will be halted. In the SLEW position, which will be enabled only when the MODE SELECT switch is in MAN position, the reader will continuously move at read speed in the selected direction for as long as the "Tape Direction Selector" is held in position. When the direction switch is released, the reader will stop on the next EOB. If, when Slewing, an MØ2, an M3Ø, a %, or an EOR code is encountered, the reader will stop. When the reader is Slewing in the forward direction, data is read into buffer storage and cleared at each EOB. When Slewing in the reverse direction, no data is read into buffer storage until the direction switch is released, at which time the reader stops on the next EOB, reverses itself, and reads forward one block, inserting it into buffer storage. When in the N REF position, enabled only when the MODE SELECT switch is in MAN position, the reader will move back in the selected direction to the next sequence number on the tape.

3-9.2.1.9 BLOCK STOP - A red annunciating and guarded momentary-on device to enable operator to halt an automatic cycle at the end of the block being processed.

3-9.2.1.10 BLK DELETE - A two position device to discriminate against data blocks preceded by a slash code. In the OFF position, slash code blocks are ignored but are displayed on the CRT for information only. In the ON position, slash code blocks are executed.

3-9.2.3 The Machine Tool Panel (Figure 37) provides those control devices peculiar to the operation of the ATLAS Tape Layup Machine.

3-9.2.3.1 The FEEDRATE selector permits modification of the programmed feed rate in 10% increments from 0% (FEED HOLD) to 120% but never greater than the maximum allowable axis velocity. It will override the programmed feed rate when the system is in AUTO mode. When the system is in MAN mode it will control the rate of the MACH ZERO movement and override the continuous JOG mode.

3-9.2.3.2 The AXIS JOG SELECT permits the selection of an axis for a JOG, MACH ZERO or SET ZERO move when the system is in the MAN mode.

3-9.2.3.3 The JOG SELECT permits the selection of any of the continuous JOG modes; 1.5 IPM (LO), 15 IPM (MED), or 150 IPM (HI) or any of the six incremental JOG modes at a fixed rate of 10 IPM.

Note: Feed rate override is disabled when the JOG SELECT is set to any one of the incremental modes.

3-9.2.3.4 The "JOG Execute" switch selects the \pm direction the selected axis will move and initiates the movement. Additionally, this device will initiate the MACH ZERO operation.

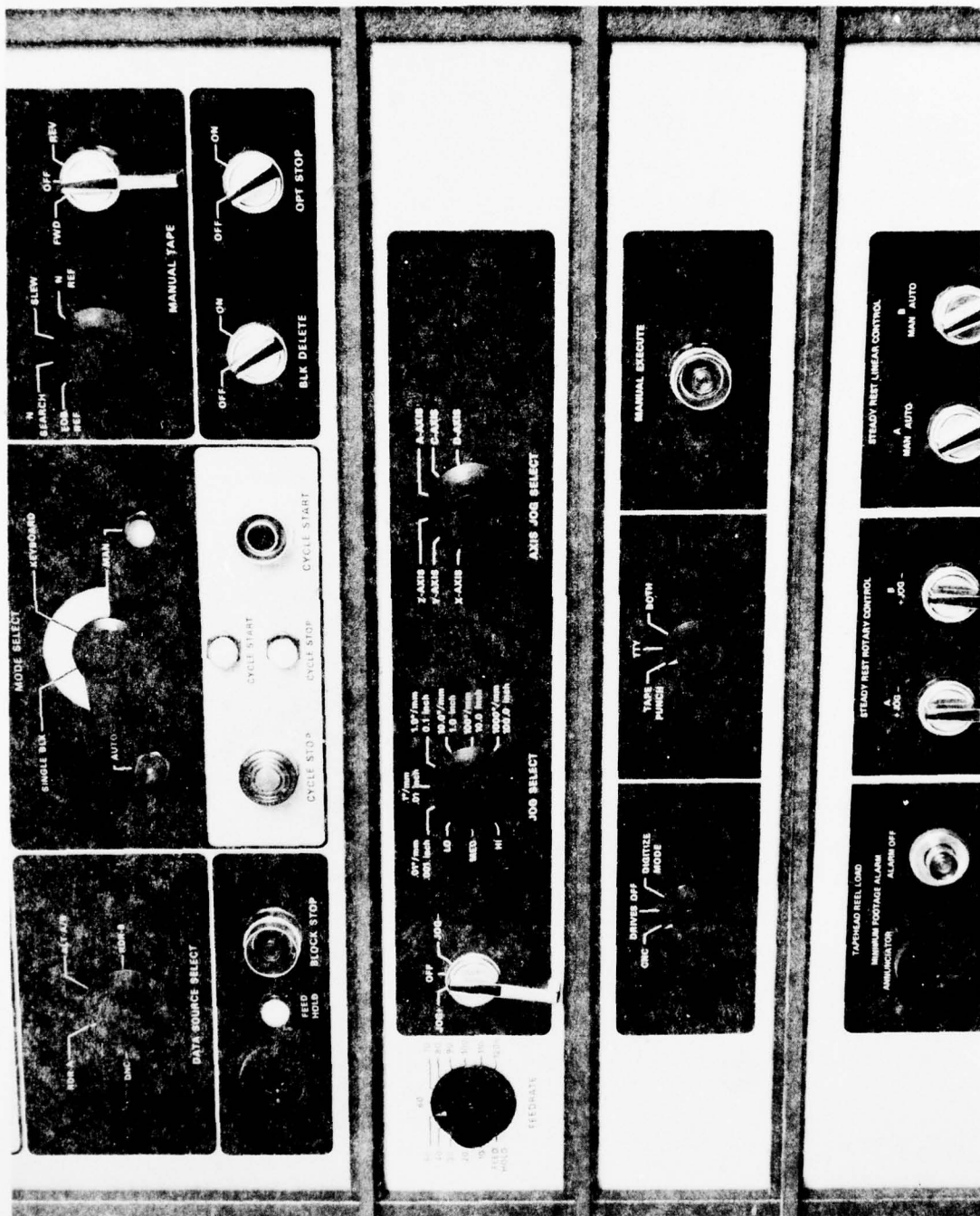

Figure 37. Machine Tool Panel

3-9.2.4 The Tape Reader/Spooler Panel (Figure 38) provides those control devices required for operation of the Tape Reader/Spooler.

The ATLAS configuration has one tape reader. It is enabled by the NC POWER switch as evidenced by the illumination of the capstan. The toggle switch at the left end of the capstan will enable the capstan brake when in the RUN position. On a subpanel at the bottom of the tape reader panel are four devices; a selector an annunciator, and two push buttons. The selector enables the READER ONLY mode, in the left position, only when the DATA SOURCE SELECT switch is in one of the three reader positions. The READER SPOOLER mode, in the right position, is functional any time the tape reader is enabled. The tape drive is turned OFF in the center position. The clear POWER annunciator will illuminate only in the READER SPOOLER mode and the two push buttons, one in each lower corner, determine the direction of travel of the Spooler. The tape reader normally feeds from left to right and is loaded with the sprocket holes toward the back of the panel.

3-9.2.5 The Digitizer Panel (Figure 39) provides those control devices required for operation of the accessory line follower equipment.

3-9.2.5.1 "Mode Select" - A three position rotary device to enable operator to select the desired control mode. The "Control Mode Selector" selects between the CNC (Computerized Numerical Control) mode (to the left), the DIGITIZER MODE (to the right) and OFF (center). The CNC position puts the system under the control of the Numerical Control Unit.

3-9.2.5.2 The "Printout Selector" selects which peripheral device will be utilized for the Digitizer printout; the TAPE PUNCH, the TTY or BOTH.

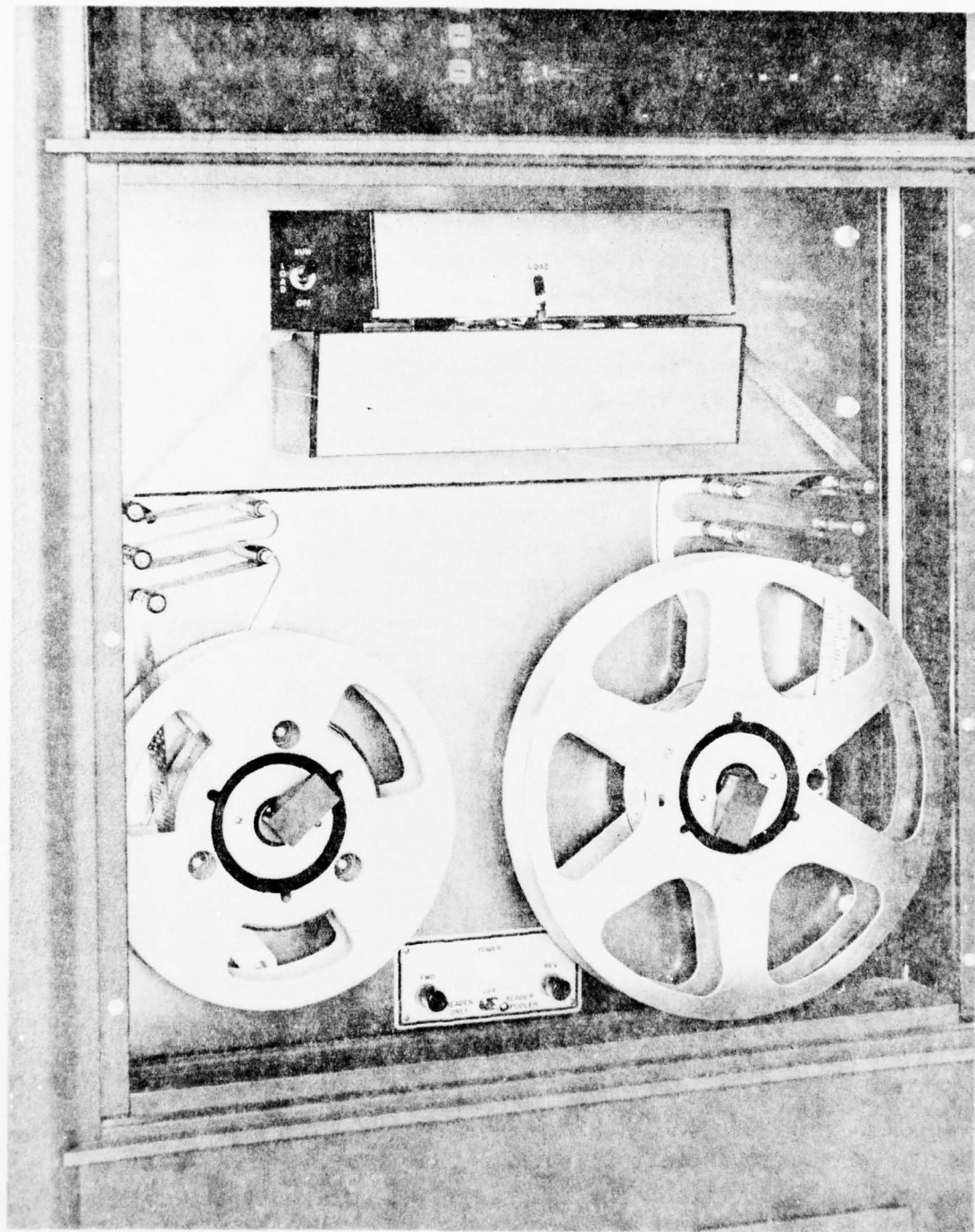
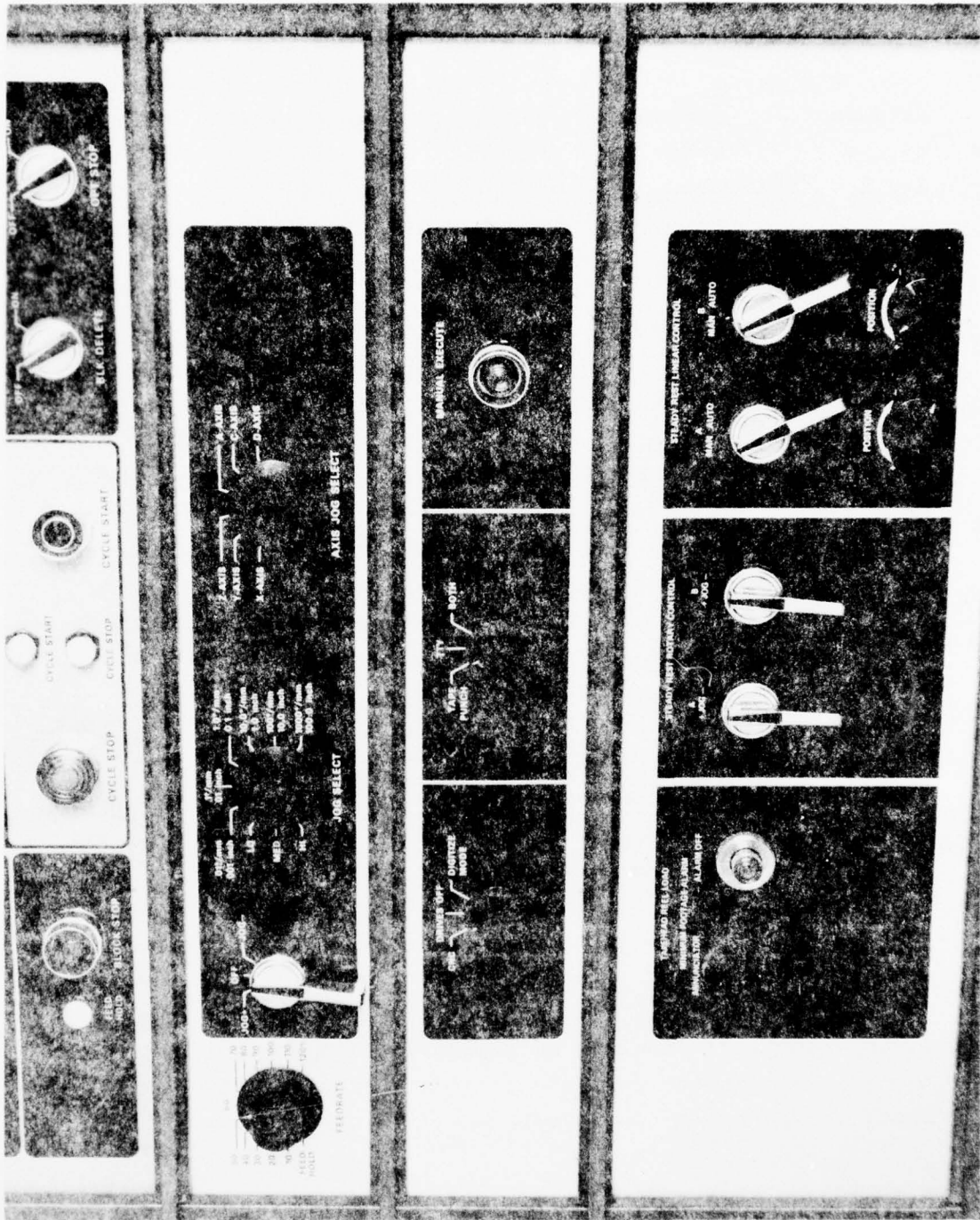

Figure 38. Tape Reader/Spooler Panel



3-9.2.5.3 MANUAL EXECUTE - an amber annunciating and guarded momentary-on device to enable operator to cause a desired block of data to be transferred to the selected printout device.

3-9.2.6 Steady Rest Control Panel (Figure 40) provides those control devices required for operation of the two accessory Steady Rests.

3-9.2.6.1 STEADY REST ROTARY CONTROL - Two self-centering, left and right momentary-on devices are provided to jog either Steady Rest in the desired rotational direction.

3-9.2.6.2 STEADY REST LINEAR CONTROL - A two position device is provided for each Steady Rest to allow the operator to select either the manual or automatic control mode to be effective.

When either Steady Rest is in the manual control mode, it can be moved by rotation of the knob located beneath the effective selector device.

When either Steady Rest is in the automatic mode it will remain stationary until the Gantry enters a preset proximity zone at which time the Steady Rest will move in such a manner as to maintain the distance between itself and the Gantry.

3-9.2.6.3 TAPE HEAD REEL LOAD - An audible annunciator and control device are provided to announce to the operator that the Payoff Reel contains no more than 20 feet of Tape. The operator can silence the audible alarm by depressing the control device but the lamp within the device will remain enabled until a new tape spool is placed on the Payoff Reel.

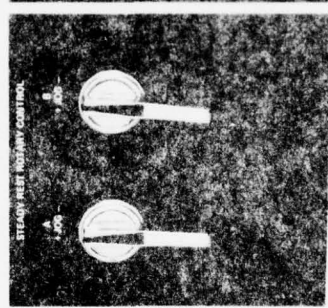
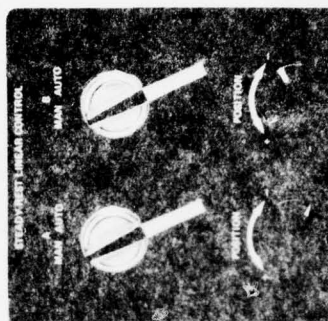
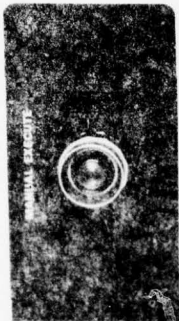

AD-A037 447

GOLDSWORTHY ENGINEERING INC TORRANCE CALIF
U.S. ARMY AUTOMATED TAPE LAYUP SYSTEM 'ATLAS'.(U)
DEC 74 D S STEWART

F/G 13/8

UNCLASSIFIED

DRSAV-76-37

DAAJ01-72-C-0610

NL

2 OF 4
AD
A037447



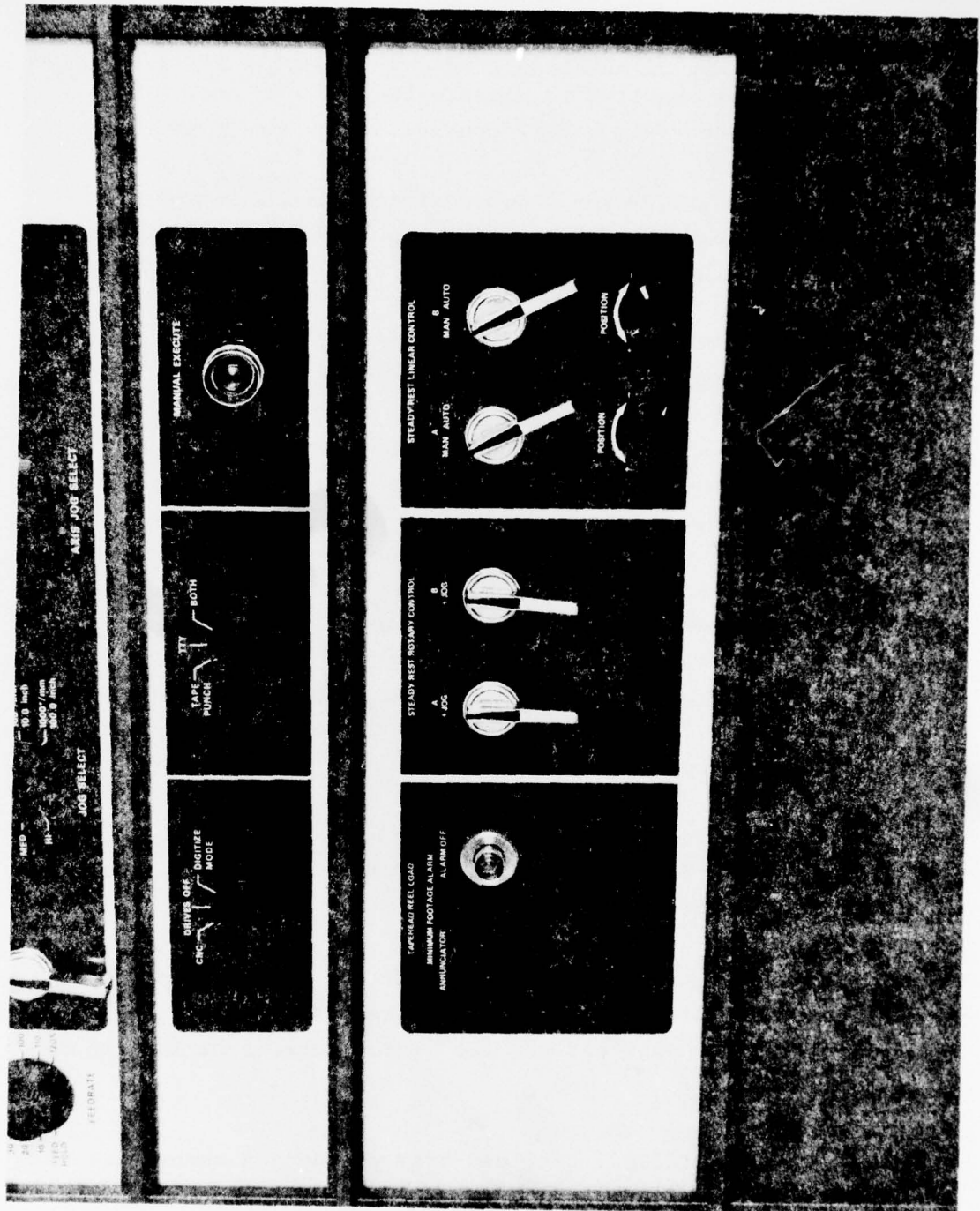

Figure 40. Steady Rest Control Panel

3-9.2.7 Motor Control Center Panel (Figure 41) provides those control devices required to disable the "A", "C" and "D" axes as well as the linear and rotary control of the two Steady Rests.

3-9.2.7.1 AXIS CONTROL - A two position device is provided to enable or disable the "A" and "D" axis drive motors. A similar device is provided to control the "C" axis drive motor.

3-9.2.7.2 STEADY REST CONTROL - A two position device is provided to enable or disable the rotational drive motors for both Steady Rests. A three position device is provided to disable both linear drive motors, enable the 'A' drive motor and enable both the 'A' and 'B' drive motors.

3-9.3 Motor Control Units - The two cabinets housing the motor drive amplifiers are shown in Figure 42. The cabinets are positioned adjacent to the Allen-Bradley 7300 control.

3-9.3.1 Main 3 phase power enters the left hand cabinet via a main disconnect, which is operated by a lever mounted on the door of the cabinet.

3-9.3.2 The left hand cabinet also contains a 3 axis (for "X", "Y", "Z") and a 2 axis ("A", "D") hyperloop drive amplifiers with associated inductors.

3-9.3.3 The right hand cabinet contains a 2 axis hyperloop drive for the rotary steady rests and 3 Westamp drive amplifiers controlling the "C" axis and the two linear motions of the steady rests.

3-9.3.4 Fuses, relays, overload trip contactors associated with the drivers, are located in both cabinets.

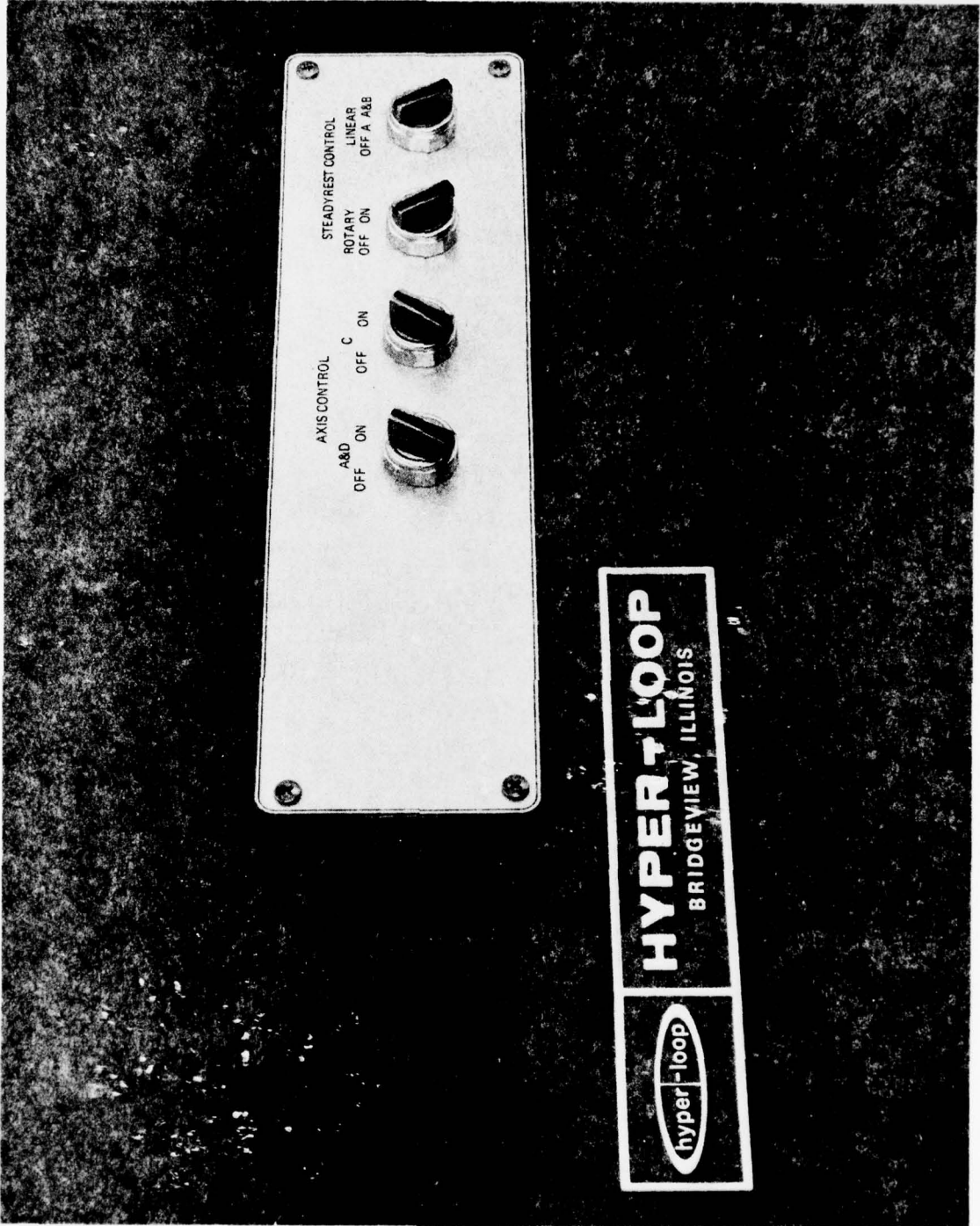

Figure 41. Motor Control Center Panel

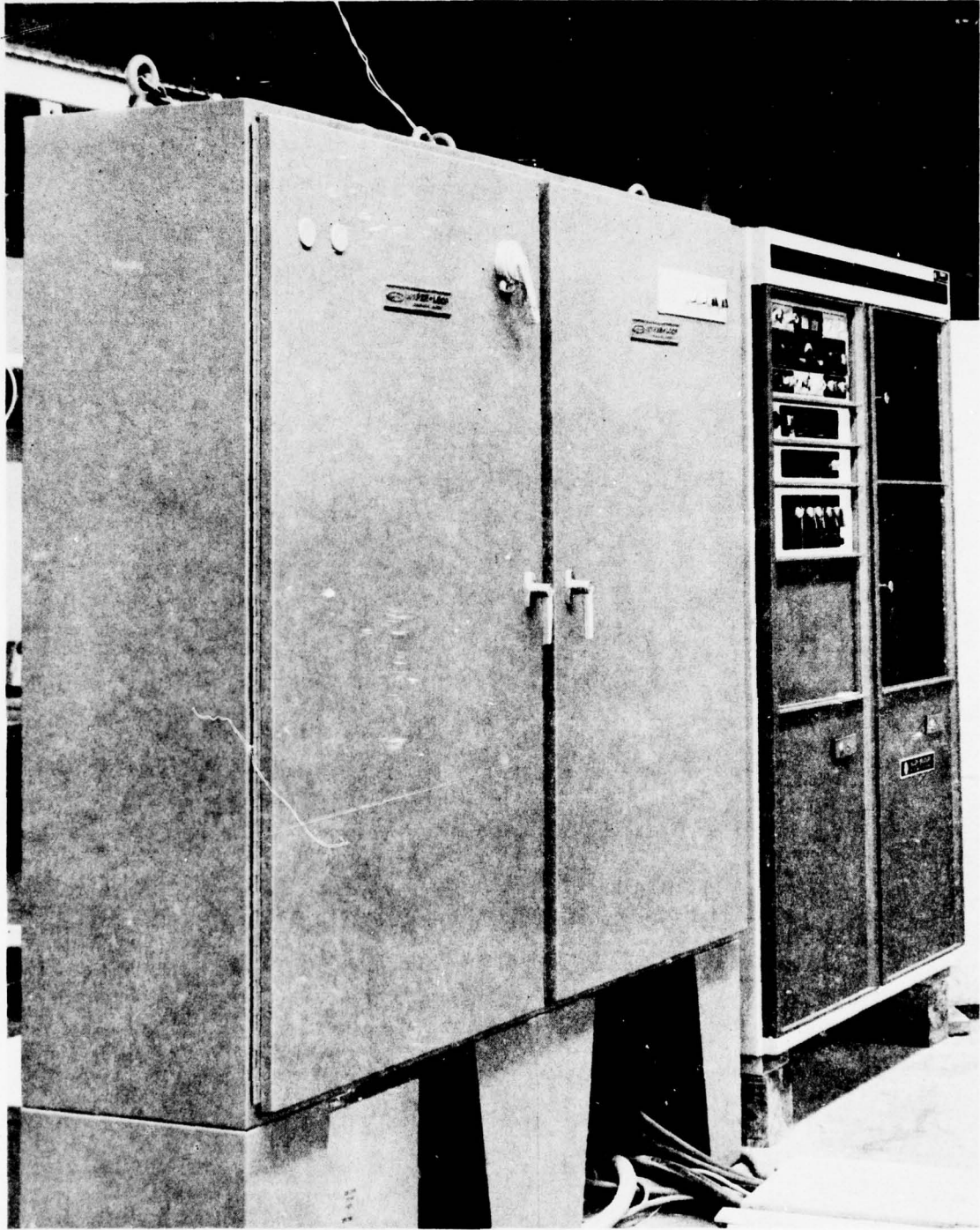

Figure 42. Motor Control Center

SECTION IV
MACHINE FABRICATION

SECTION IV

MACHINE FABRICATION

This section covers the complete fabrication program of the ATLAS machine at the Contractors Facility in Torrance, California.

It covers various aspects of the fabrication of the machine sub - assemblies: design and development work on the line follower and steady rests:

General Assembly and Alignments

Machine/Numerical Control Integration

Preliminary Tests and Demonstrations

Dis-assembly and Shipping to the Boeing
Vertol facility in Philadelphia, PA.

In terms of time span it covers the period between May 1972 and December 1973.

4-1 Base Sections - The program scheduling showed that the main base sections would be pacing items in the fabrication of the machine. Some minor re-design was done to allow for additional ways to be set down below the working surface, for the traveling steady rests.

4-1.1 The design of the cast iron bed sections had been done so that they were of modular box section form, in 2 ft. increments.

4-1.2 To achieve the 56 ft. bed length required for a gantry movement of 36 ft., four 14 ft. long bed sections were used with another set of four along side with the join on the machine centerline.

4-1.3 To obviate the need for precise machining of the ends of the 14 ft. sections to make them exactly to length and square with the sides, the design was made to group the bed sections in four pairs. Each pair was joined along the machined surfaces on the machine centerline. The pairs were then butted together at their ends, and machined spacers used to set up the exact alignment between them.

4-1.4 Casting of the base sections was done locally, using a 40,000 psi iron. Each section weighed 8,750 lbs.

4-1.5 Figure 43 shows the first bed sections being positioned for assembly.

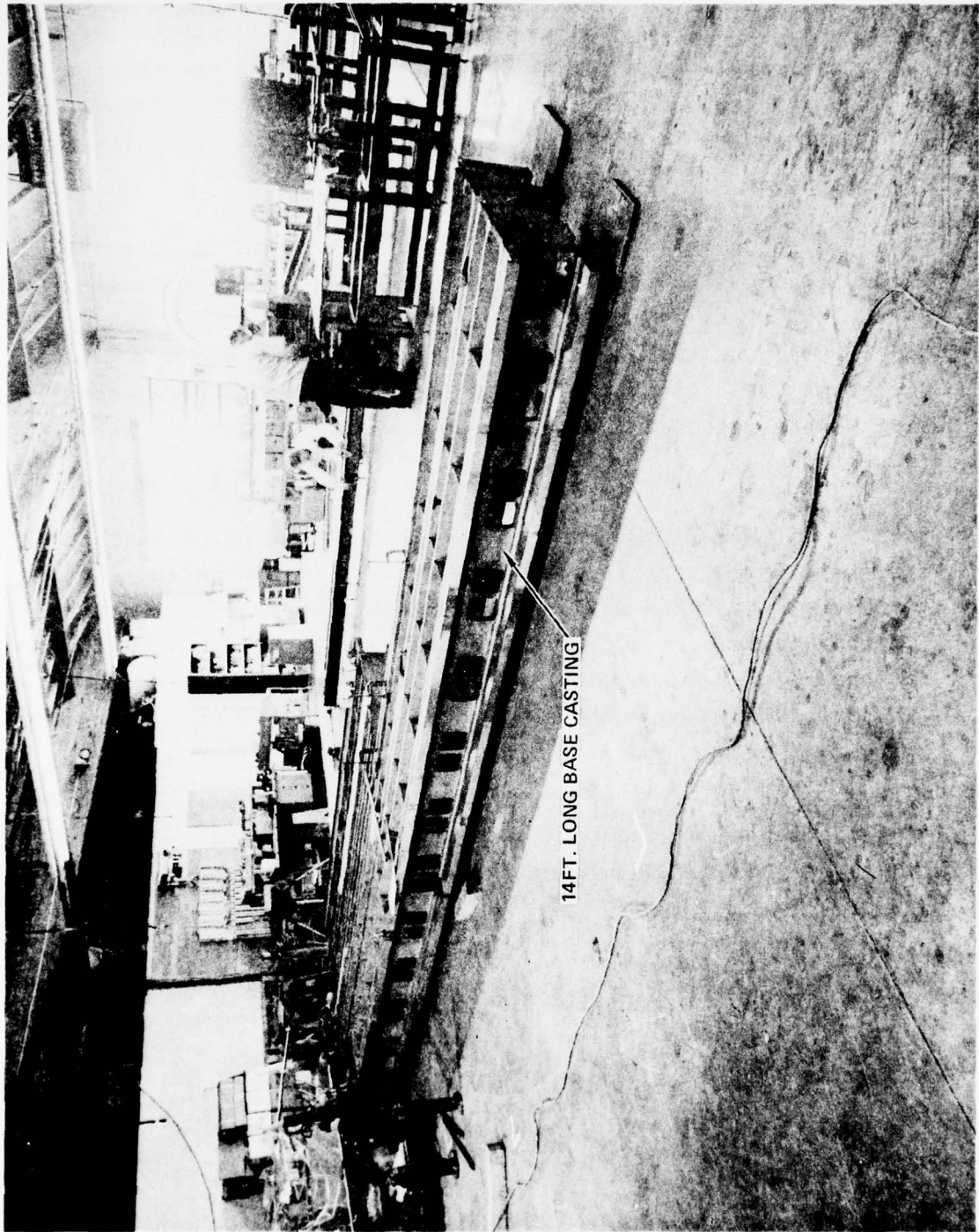

Figure 43. Base Section Castings

4-2 Composite Gantry - In the preceding design contract it had been decided to use a composite fabricated gantry. Studies showed that it would be adequately stiff enough for a tape layup machine, and that the fabrication cost, when compared to metal structures, would be lower.

The fabrication of the gantry was achieved in four phases;

- (a) Scale model development of shape.
- (b) Full scale wooden mock-up.
- (c) Female molds made on wooden mock-up.
- (d) Fabrication of one piece gantry structure, in the molds.

4-2.1 Scale Model of Gantry - A 1/8 scale model of the gantry was made so that the compound curved surfaces and corner radii proportions could be more easily developed. It also provided a very useful tool in the discussions with prospective fabrications as mold parting lines and fabrication sequences could be worked out.

Figures 44 and 45 show two views of the scale model, including the front eye-brow cover, also to be molded in glass fiber.

4-2.2 Full Scale Wooden Mock-up - The basic plywood structure for this mock-up had been constructed during the previous design contract.

Using the 1/8 scale model as a guide, the fabricator built up the mock-up using wood and plaster.

The surfaces were painted and prepared to take the glass fiber molds from it. Figures 46 and 47 show the mock-up during its construction.

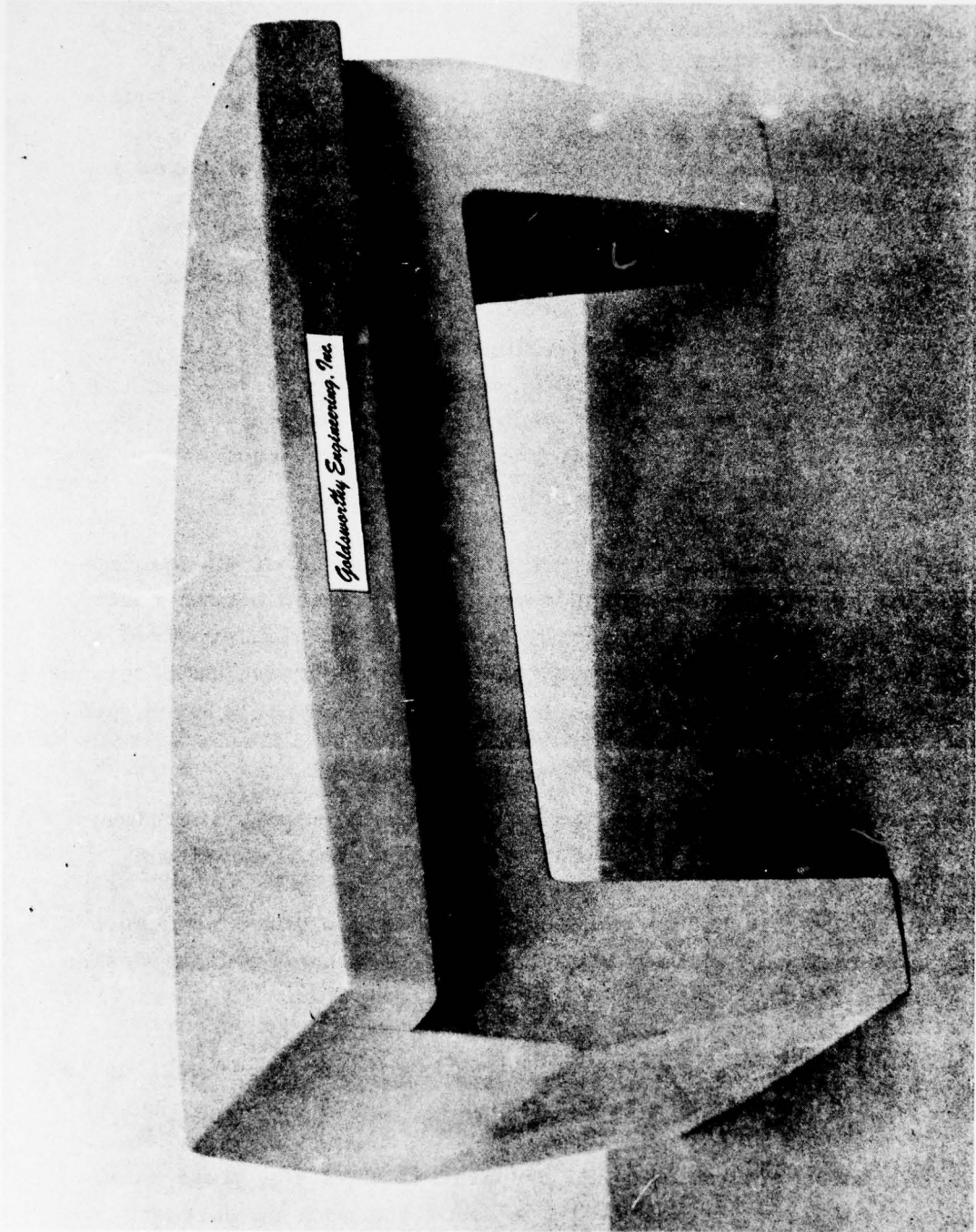

Figure 44. 1/8 Scale Gantry Model

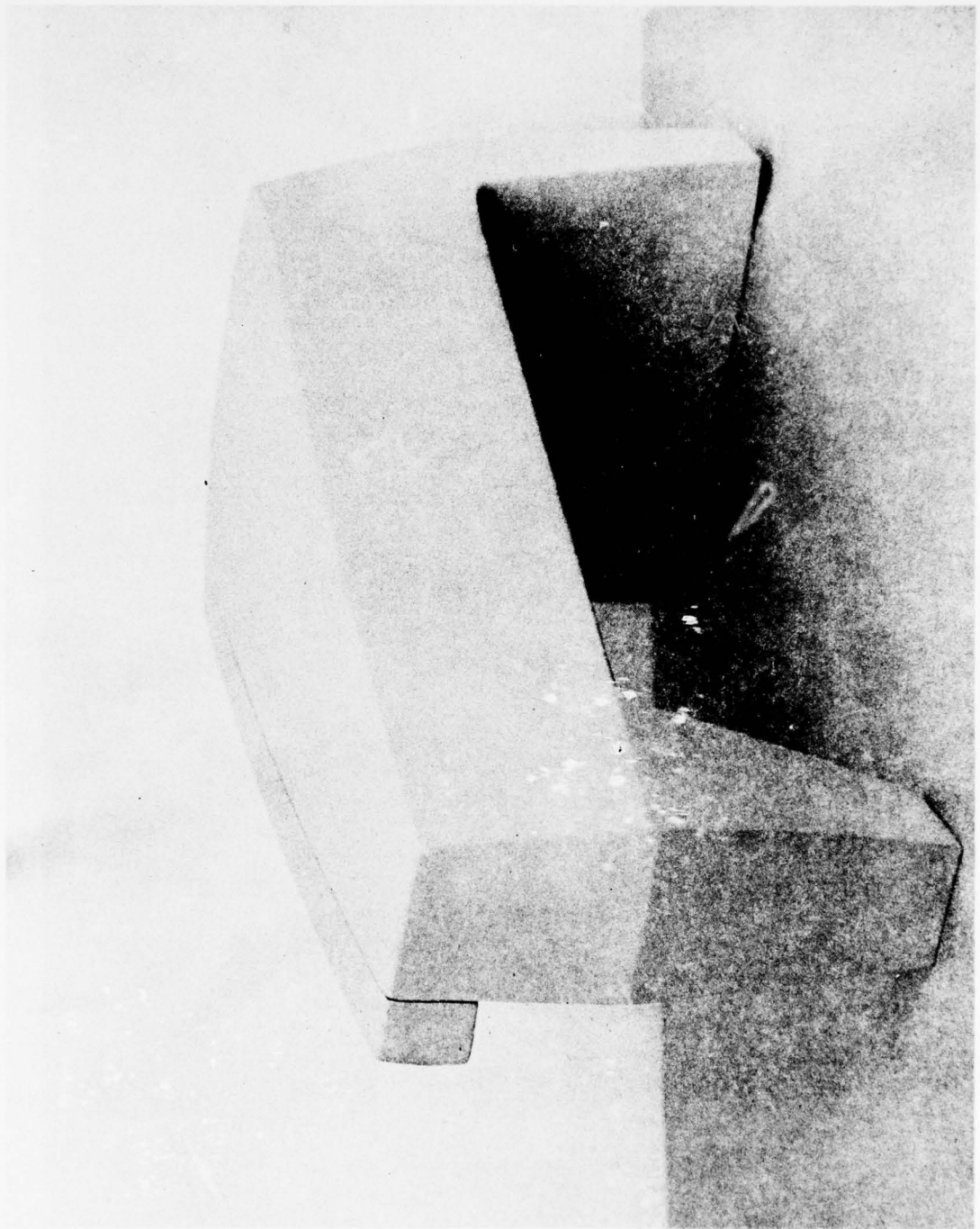

Figure 45. Gantry Model Rear View

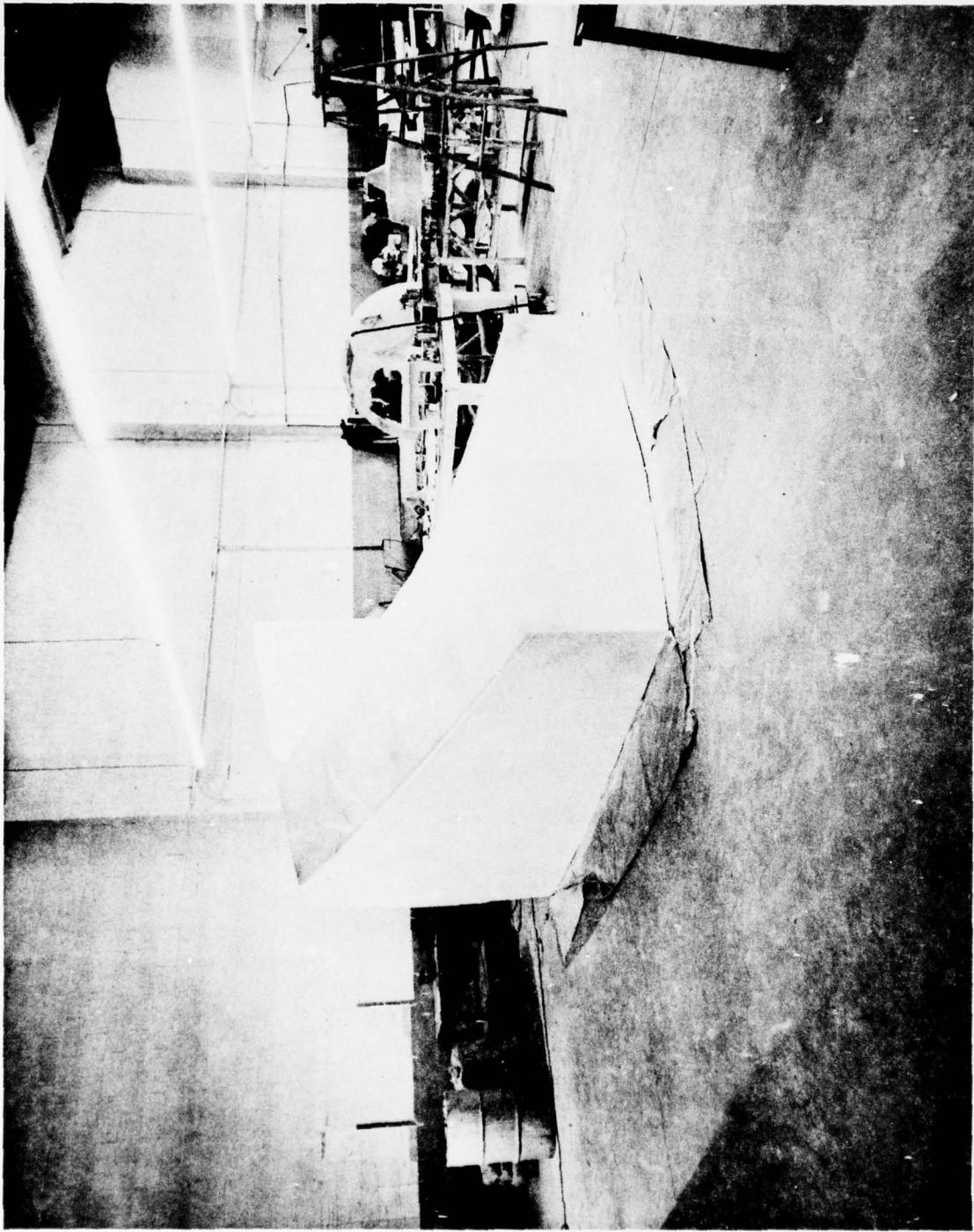

Figure 46. Wooden Gantry Mock-Up

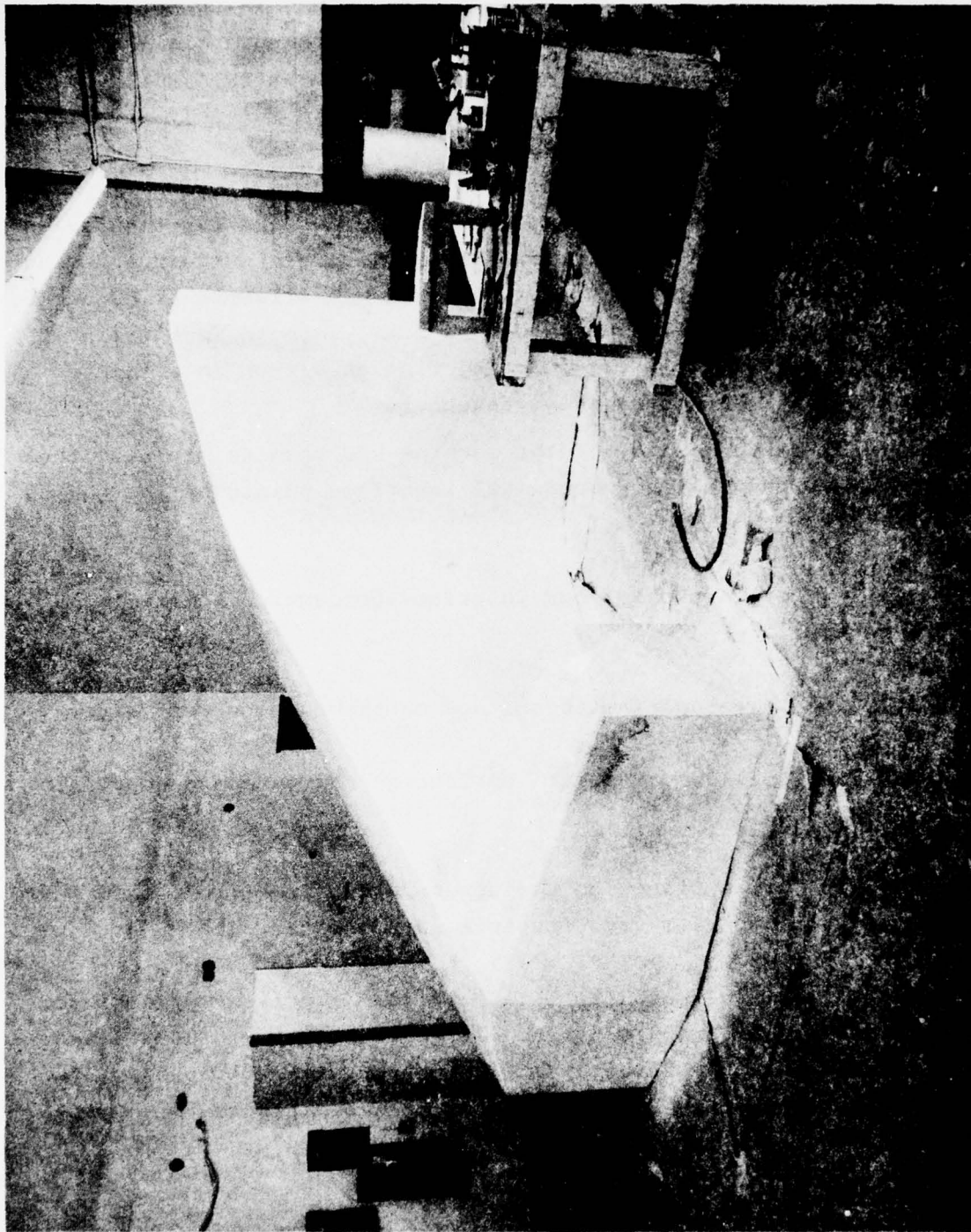

Figure 47. Construction of Gantry Mock-Up

4.2.3 Gantry Molds - The female mold was made in three sections. Each mold section was heavily reinforced to ensure minimum distortion. The sections are shown in Figures 48, 49 and 50. The molding surfaces were polished and suitably prepared for construction of the one piece gantry.

4-2.4 Gantry Construction - The basic parameters for the design of the gantry were that it would be a one-piece structure having .180" thick polyester resin impregnated glass fabric skins backed with 2 and 4 pound density urethane foam, with an inner skin of .125" thickness. Interconnecting ribs at 6 inch intervals to tie the inner and outer skins together.

The basic design policy of the machine had been to minimize the number of load bearing mechanical interface points on the gantry structure.

4-2.4.1 There are only four interface connection points on the gantry.

4-2.4.1.1 Large underneath surface on the main support side.

4-2.4.1.2 Smaller underneath surface on the outboard supporting leg side.

4-2.4.1.3 Two surfaces on the upper part of the front face where the vertical tubular way structures are located.

4-2.4.2 Positive metal to metal surface interface was achieved by fastening external aluminum plates through to insert plates laminated into the structure. The outer skin at these points is being sandwiched between the two plates. Figure 51 shows a typical section through the gantry.

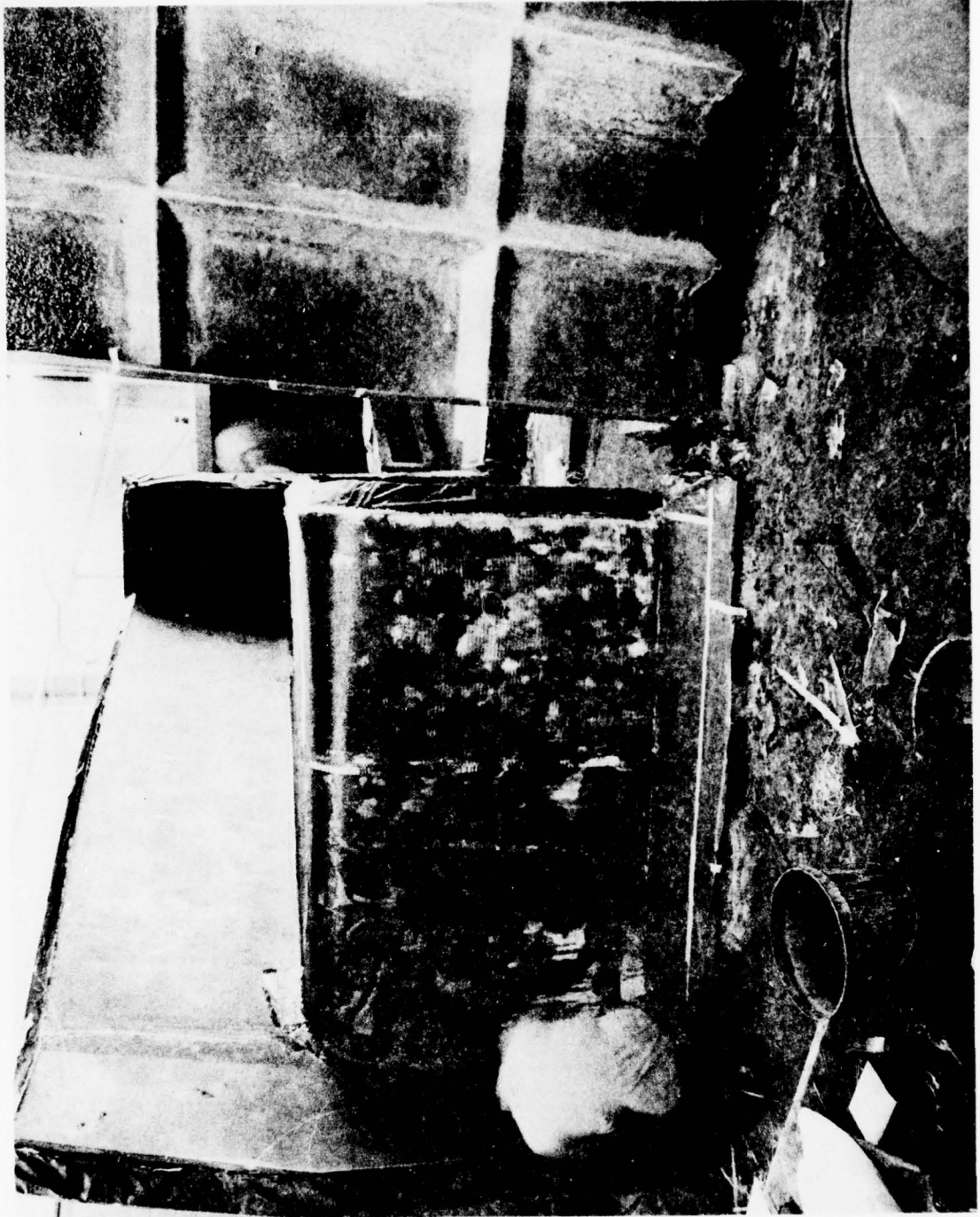

Figure 48. Gantry Mould Sections

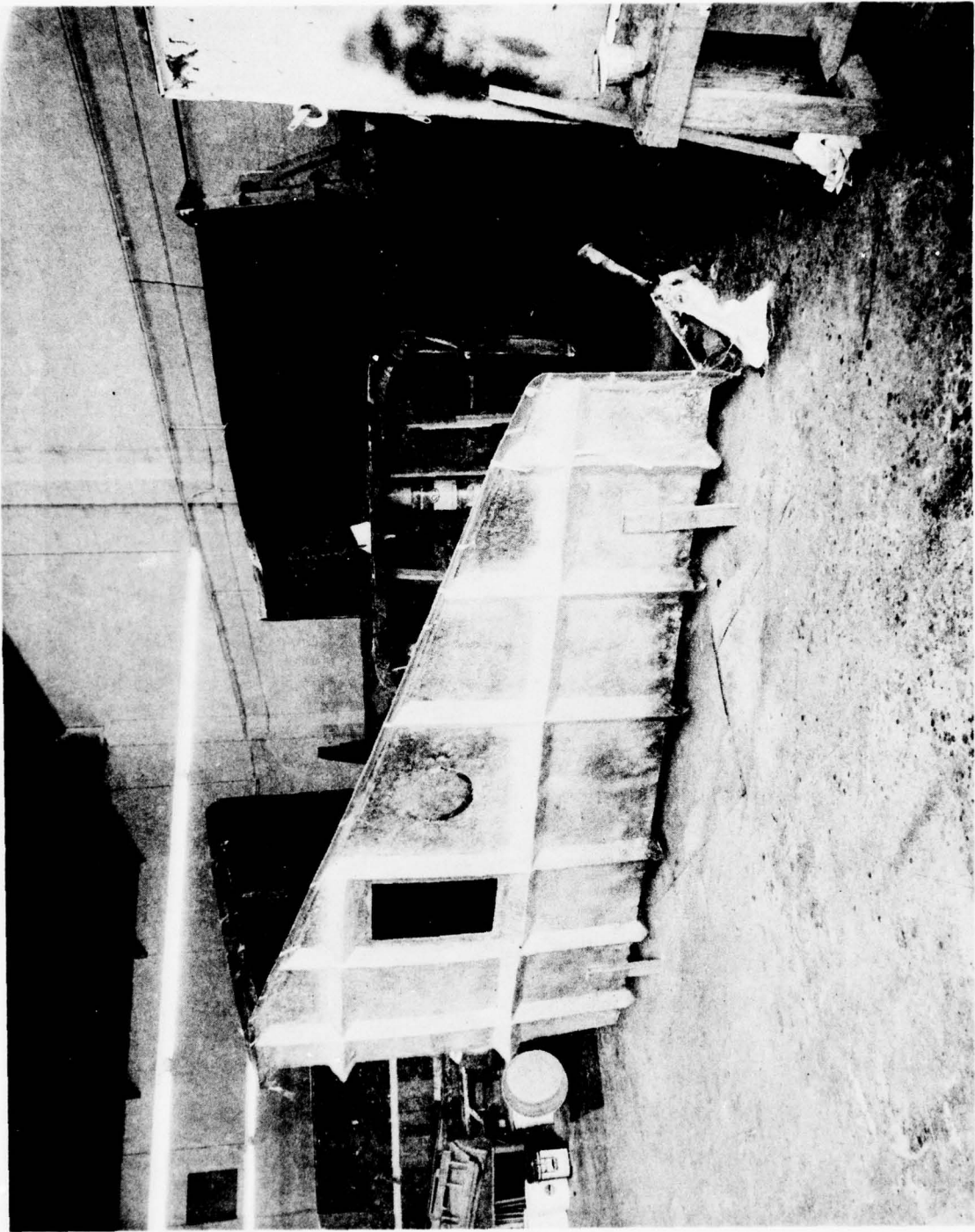

Figure 49. Gantry Mould Sections

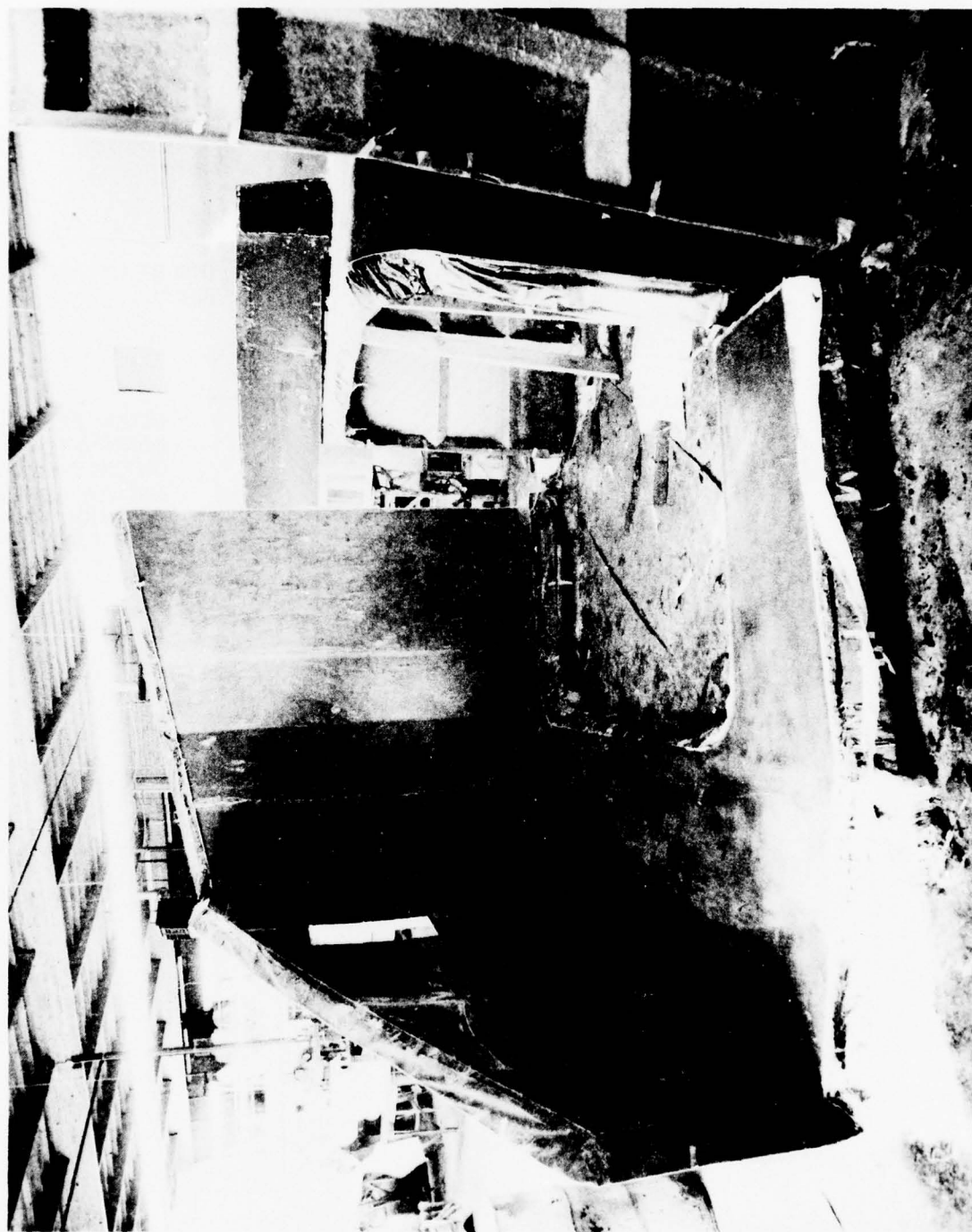

Figure 50. Gantry Mould Sections

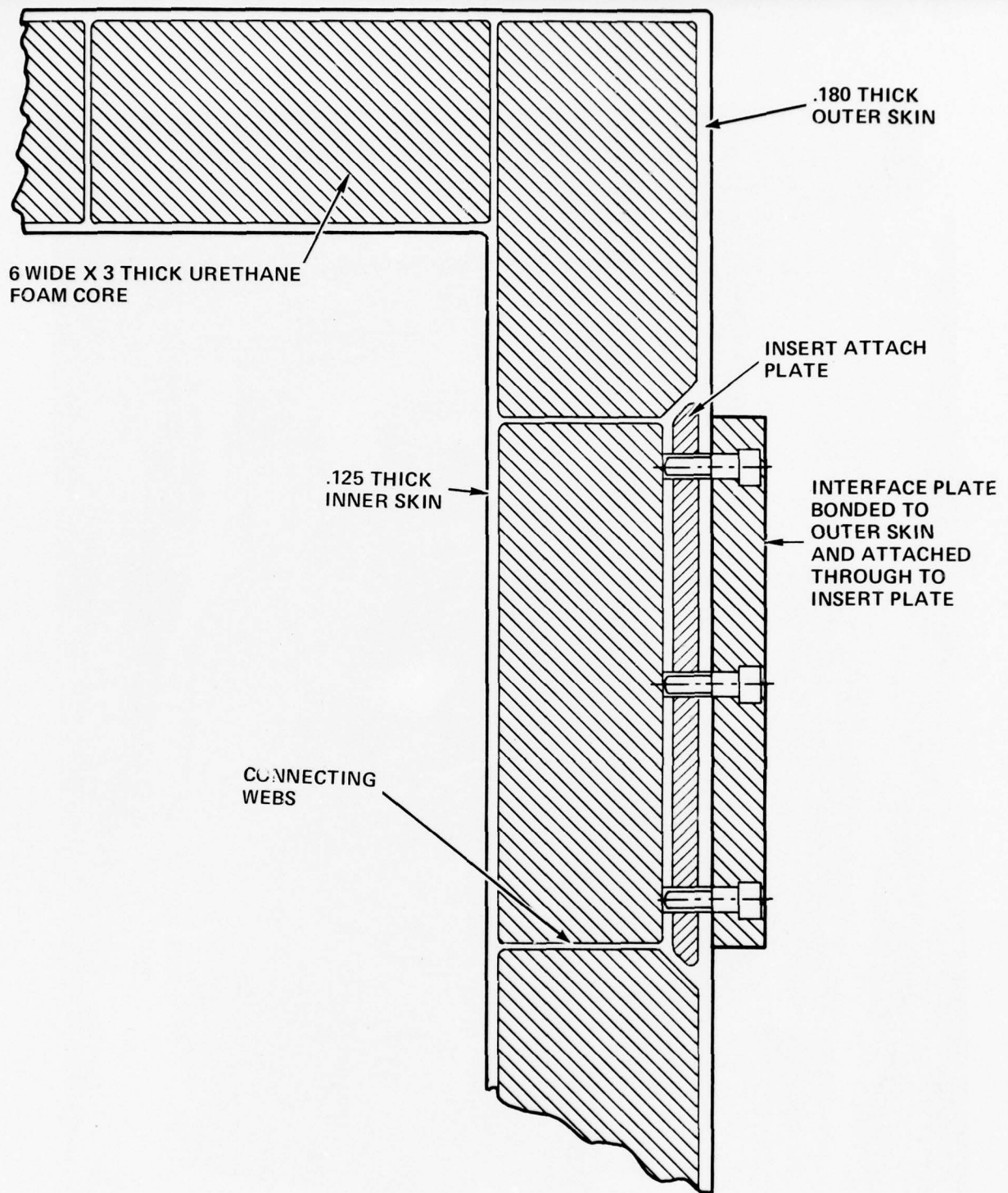

Figure 51. Typical Section Through Composite Gantry

4-2.4.3 The outer skin was make up of:

a gel coat

surfacing mat

1-1/2 oz. chopped strand mat

woven fabric

24 oz. woven roving interspersed with mat

all to make up the .180 inch thickness.

4-2.4.4 The interconnecting webs, between the outer and inner skins were achieved by wrapping the foam "logs", 3" thick by 6" wide, in resin impregnated glass cloth and setting against the outer skin in the mold. The wrapped "logs" were placed side by side to make up the complete structure prior to layup of the inner skin.

4-2.4.5 The one-piece construction was achieved by layup of the outer skin and foam core in the three mold sections, but leaving the core away from the joining edges of the molds. The three sections were then brought together. The joining edges were bridged across with additional layers of glass cloth, to tie the outer skins together. The remainder of the foam cores were then put in place and the inner skin laid up to complete the structure.

4-2.4.6 Access to the inside of the gantry is by means of a rectangular hole in the top surface.

4-3 Composite Cross Beam

In keeping with the policy for having the machine structure as light as possible, the use of a glass fiber composite structure for the large cross beam proved to be successful.

4-3.1 Construction of the beam was from three 6" foam cored panels. Each panel consisted of .180" thick polyester resin with 2 lb./ft.³ density urethane foam core and interconnecting ribs between the skins at 6 inch intervals.

4-3.2 The edges of the panels were closed in by pultruded channel sections of 5/16 inch nominal thickness, made by the Contractor.

4-3.3 Aluminum strips, on the lower and upper surfaces, bonded with epoxy adhesive and fastened to the pultruded channel with screws and metal inserts, provided surfaces for attaching the ways for the "Y" axis carriage.

4-3.4 Figure 52 shows a plan view part section of the beam cut away to show the skins and interconnecting webs.

4.3.5 The effectiveness of this fabrication technique is borne out by the lightness of the beam (465 pounds) in comparison to its size (18 inches thick, 24 inches wide and 186 inches long.)

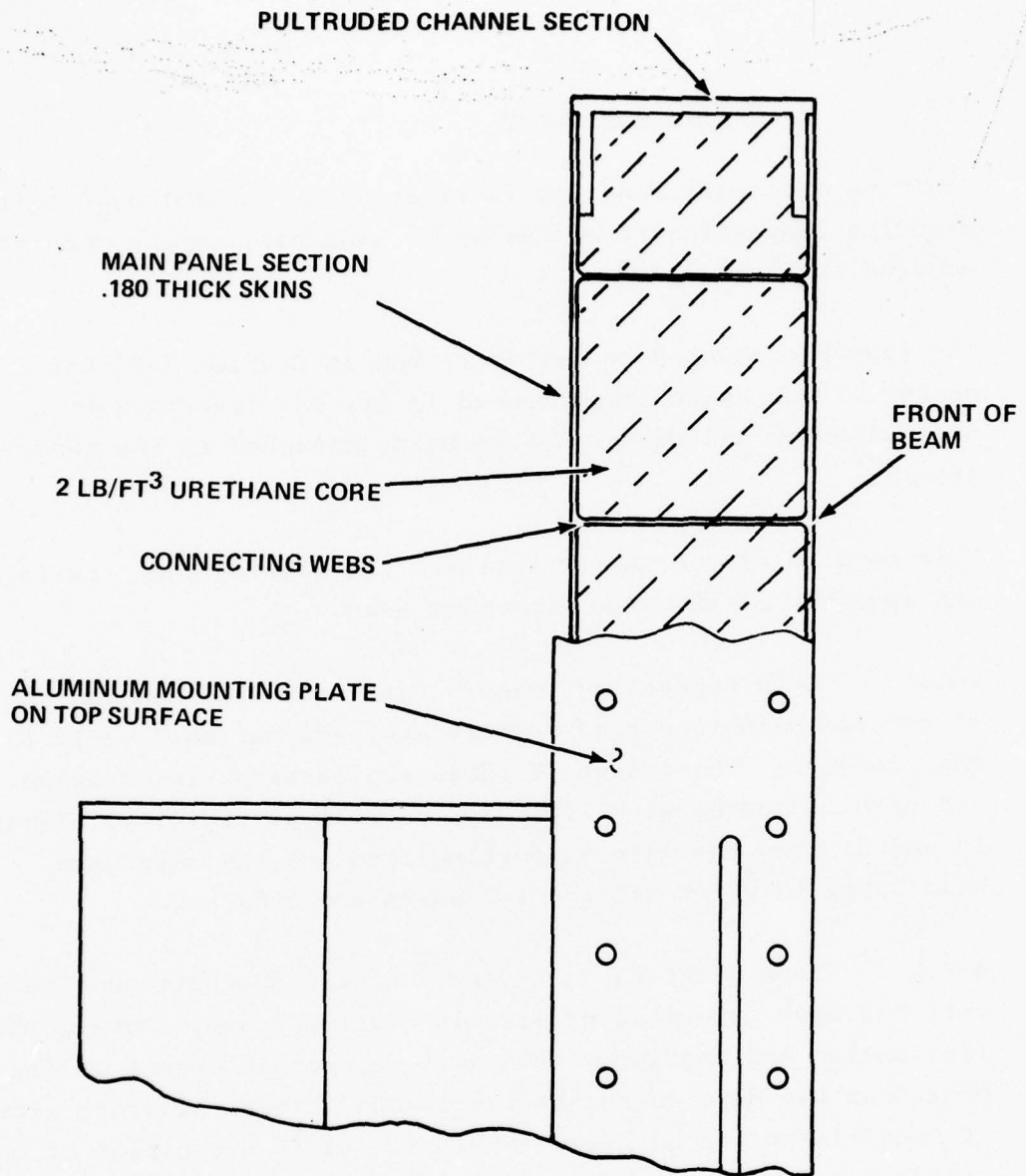

Figure 52. Part Section of Cross Beam

4-4 Tape Placement Head

The Tape Placement Head was fabricated and assembled on a free standing supporting frame, prior to attaching to the completed machine structure.

The Tape Placement Head, as described in Section 3-6, has a number of sub units incorporated in it, enabling them to be pre-assembled and tested before being attached to the head itself.

This section of the Report outlines the fabrication, testing, and assembly of the Tape Placement Head.

4-4.1 Main Supporting Frames-- Pattern making and casting of the two main tape head members were accomplished early in the schedule. The design of these two castings in aluminum had been concerned with lightness as well as rigidity. Figures 53 and 54 show the main supporting ring and the main tape head frame to which all the sub-units are attached.

4-4.2 Tape Slitting Unit- The function of the tape slitting unit has been described earlier in Section 3-6.6. During the fabrication and testing of the unit, a certain amount of development work was done to ensure continuous, clean, accurate slitting of monofilament glass epoxy tape. The basic principles of the slitting had been established during the preceding design contract.

4-4.2.1 The first task was to achieve the required setup of the knives to give clean cutting to glass epoxy filament tape. Each set of cutters has spacers between the cutting discs. By varying the thickness of the spacers, the clearance between the sides of the meshing knife discs was adjusted.

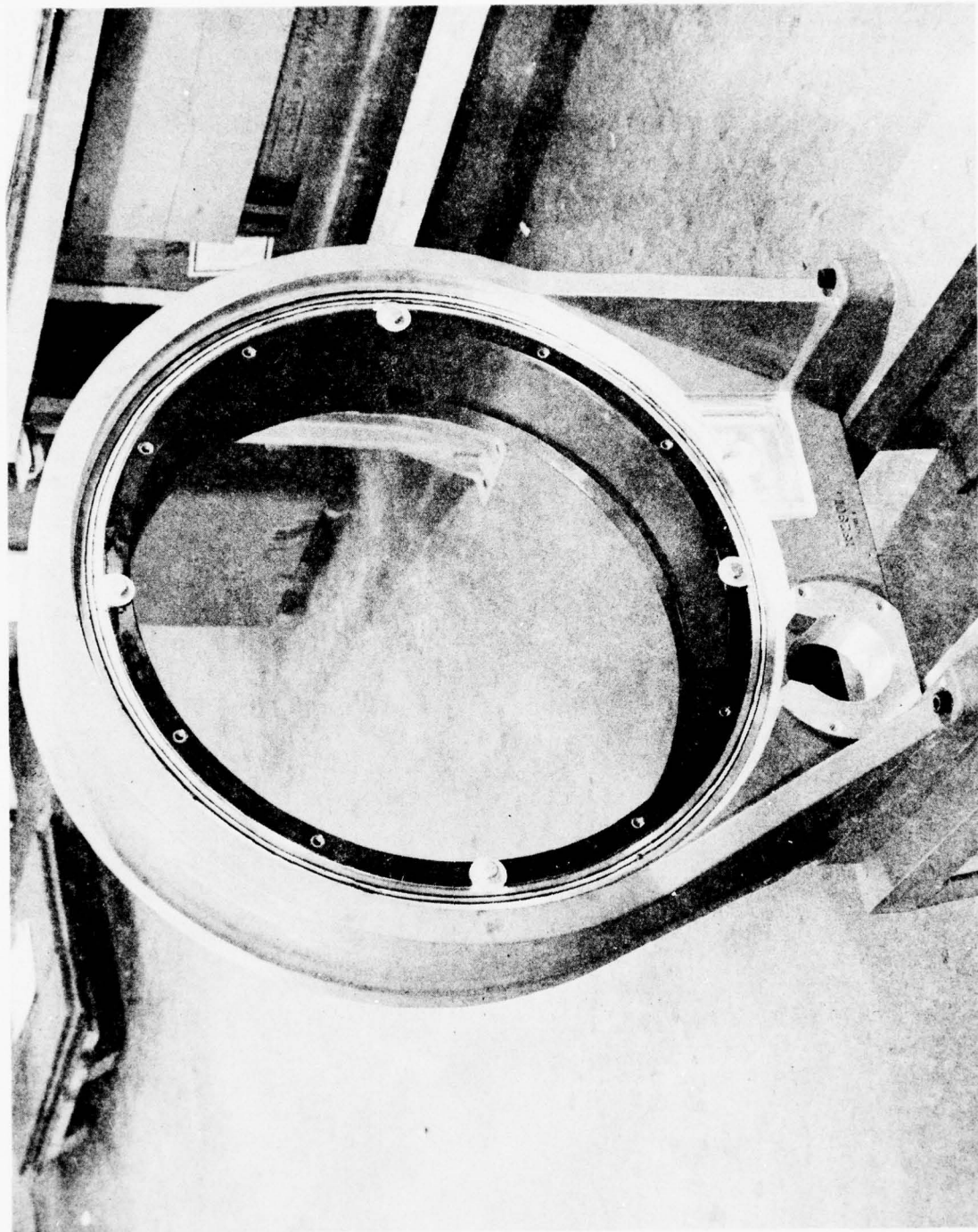

Figure 53. Main Supporting Ring

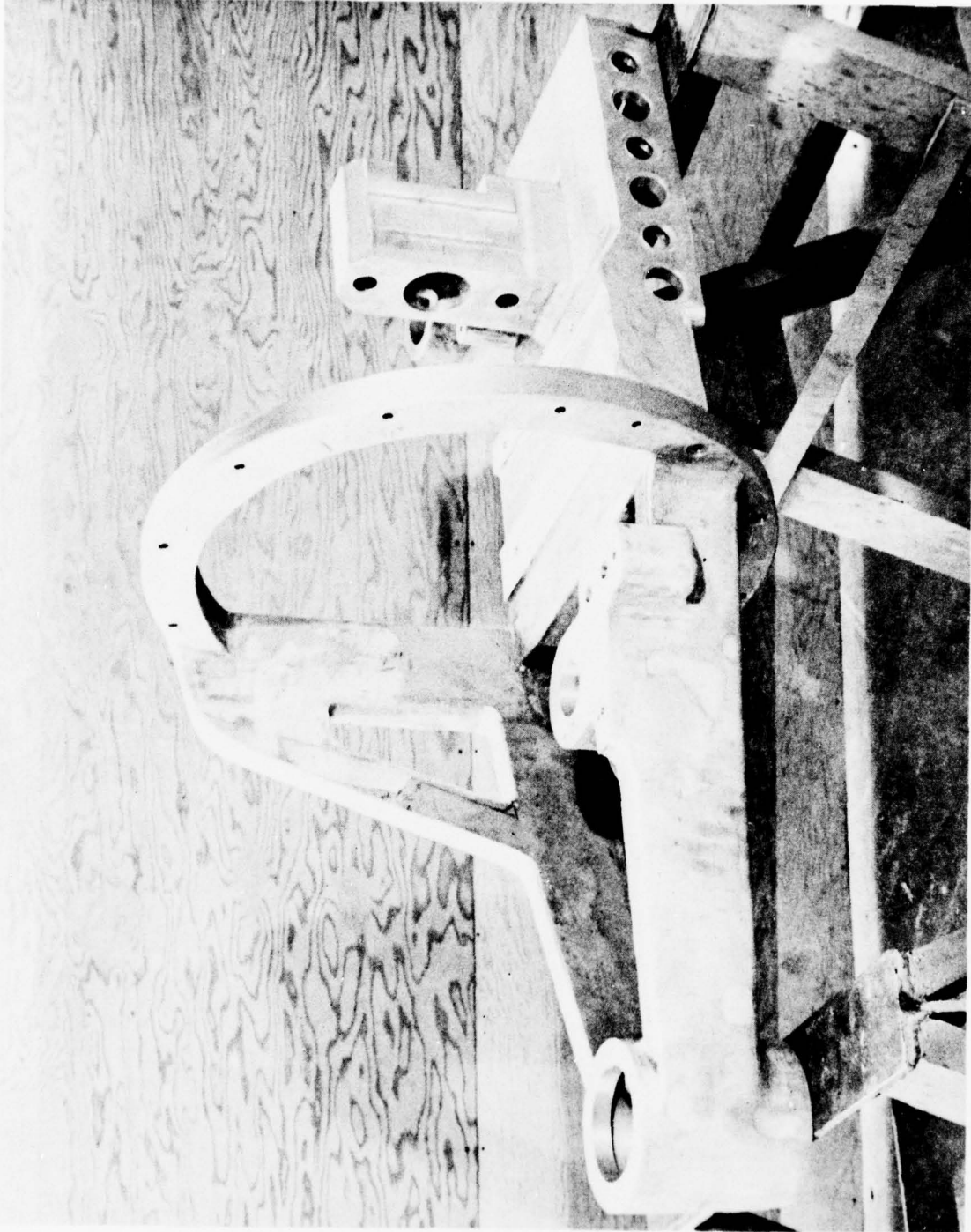

Figure 54. Main Tape Head Frame

4-4.2.2 When first assembled, the clearance between the knife discs had been set at .005". This was found to be excessive, as a number of uncut fibers bridged across between the slit tapes. The clearance was reduced to 0 to .001", which produced the desired clean cutting.

4-4.2.3 With virtually no clearance between the knife discs, accurate position of the two sets of cutters became more significant.

4-4.2.4 The other development work was concerned with the depth of mesh between the cutters and preventing the tacky side of the tapes from adhering to the spacers and pulling away from the backing paper. Clean break-away from the cutters was also a requirement so that on release of the cutters, the tapes would pull away cleanly.

4-4.2.5 To achieve these requirements, entrance rings were made up and fitted to the outside of the spacers so that the diameter of the rings was less than that of the cutting discs.

4-4.2.6 When slitting the entrance discs were slightly deformed and thus pushed the strips away on release of the cutters. Teflon shrink tubing was used to cover the entrance discs to prevent adhesion of the tacky filament tapes.

4-4.3 Tape Shear Unit - The basic principles of the Tape Shear had been developed by the contractor on previous tape placement heads. A bench mounted test rig was used to evaluate the shearing characteristics of different tape systems, and more significantly, with different types of backing paper.

The main effort during the fabrication and assembly phase was involved in setting up the automatic positioning system, which sets the shear unit angle, prior to the cutting action.

4-4.3.1 The use of an in-line D.C. torque motor, initially, was found to be unable to achieve stable positioning to the + or - 1/2 degree angle tolerance. By mounting a small geared D.C. motor to drive the shear spindle via a bevel gear segment, the required positioning accuracy was achieved.

4-4.3.2 Figure 55 shows the shear rotary drive system, with the motor and bevel gear, and the feedback by means of a precision gear driven potentiometer.

4-4.4 Tape Placement Head Rotation, "C" Axis Drive - The rotational control of the head is an integral part of it. The drive motor and gearing unit is a cartridge type assembly, easily removeable. The drive is to a 24" dia bronze gear, mounted under the rotational supporting ring.

4-4.4.1 During the initial testing phase of the whole assembly, it was found that although the drive motor produced sufficient torque to rotate the tape head, it would be insufficient to hold the head in a continuous high torque condition. Such a condition would occur when the "A" axis would be set over to more than 30° and the head positioned to lay tape in line with the Y axis motion.

4-4.4.2 The drive and gearing unit was modified to give a higher gear reduction and a higher torque D.C. motor was fitted. These proved to be capable of full control of the head under the highest torque condition.

4-4.5 Placement Roller - The design of the Placement Roller, using an inflatable reinforced tire, had been developed from previous experience with other tape placement heads. The requirement of this roller to conform to 2 inch radius surfaces resulted in a thin section tread.

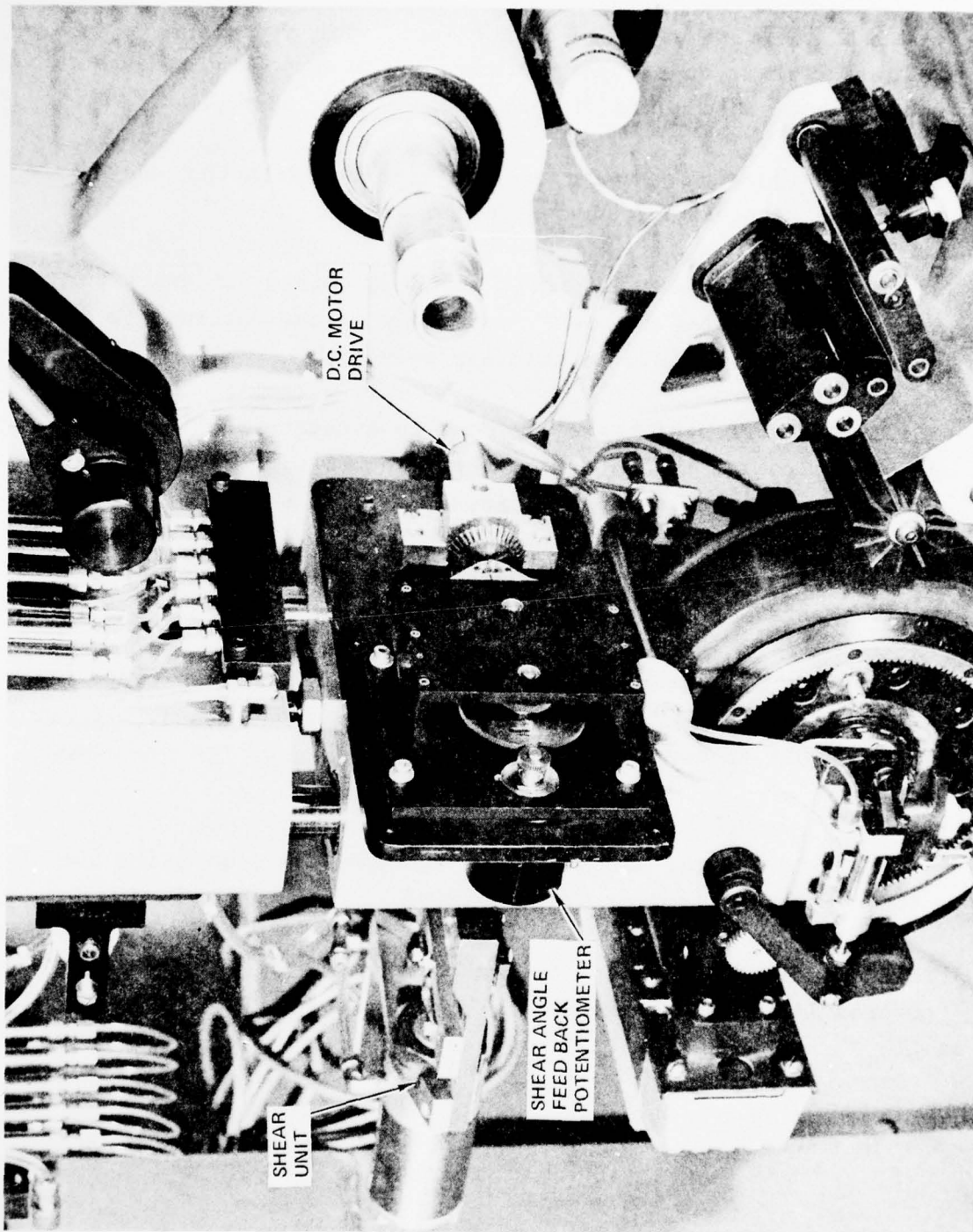

Figure 55. Shear Rotary Drive System

4-4.5.1 The tire was molded in rubber, with transverse reinforcing of glass fibers to prevent the tread from spreading sideways under load. This would displace laid strips of tape.

4-4.5.2 Figure 56 shows the tire, together with the hub and attaching flanges. Also shown is the axle.

4-4.5.3 The tire was assembled to the aluminum hub and after initial air leakage problems, caused by porous casting, were corrected, it was able to hold air pressure.

4-4.5.4 A series of tests was done to evaluate the ability of the placement roller to conform to the 2 inch radius requirement. The report on these tests appears in Appendix II.

4-4.5.5 The report concludes that the roller did meet the design requirements.

4-4.5.6 At this stage of the machine build, the tape placement head was a separate unit sitting on its assembly stand. It was not possible to test the lay-down performance of the placement roller.

4-4.5.7 During the machine check-out and test phase, the performance of the placement roller was evaluated.

Tests done and subsequent design changes in the placement area are covered later in this report.

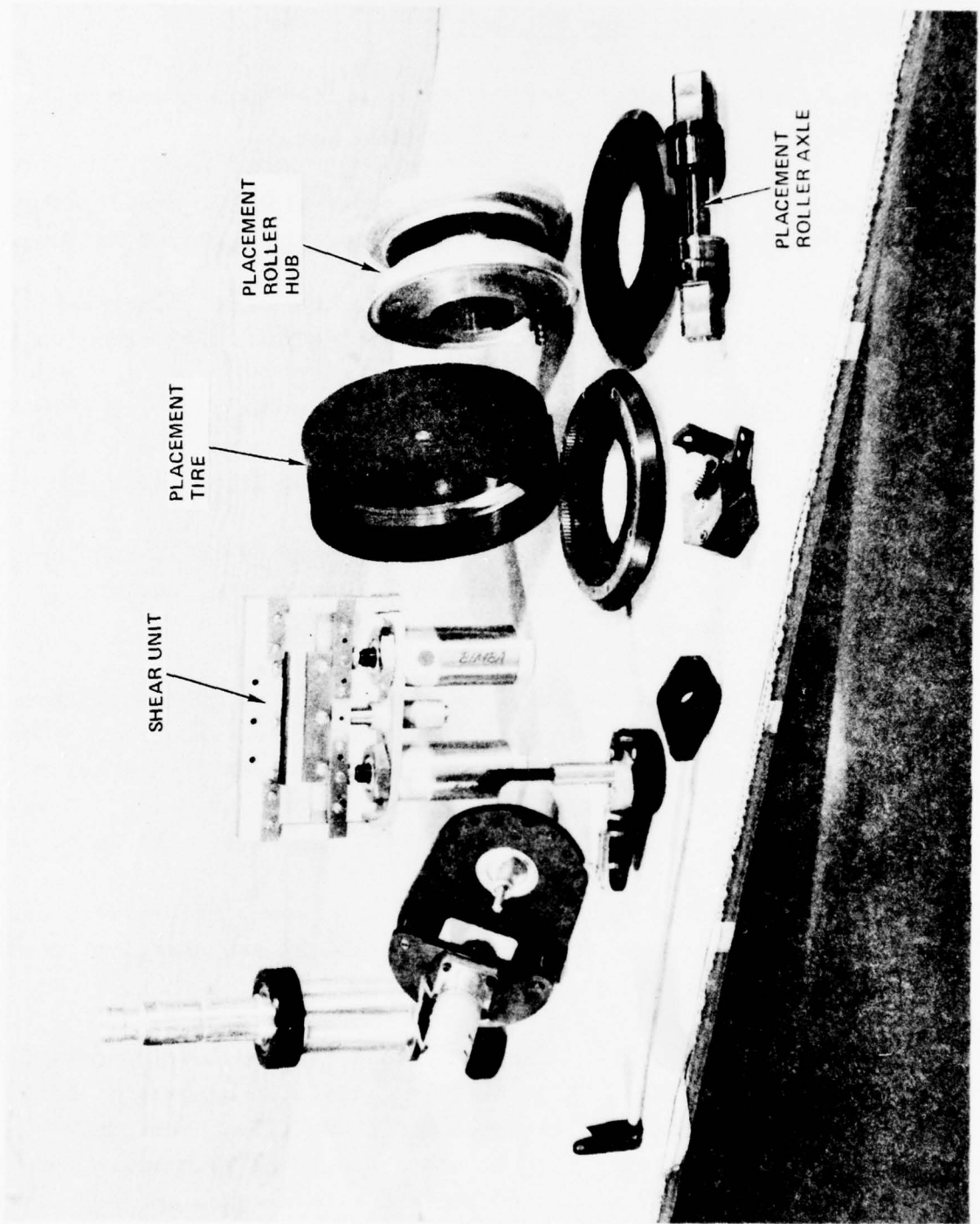

4-5 Digitizing Line Follower

The digitizing line follower system is a five axis tracer unit mounted under the tape placement head.

A survey of available electrical and photo-electric tracers showed that there were none capable of performing the required motions.

The complete development of the unit was therefore undertaken as part of the contract, and took place during the Fabrication Phase.

4-5.1. Requirements - The basic requirement was that the unit should control the five fundamental axis of the machine to follow a reference line placed on the surface of the layup tool.

Thus it would control "X" or "Y" and "C" axis by following the line, as well as "Z" and "A" axis by following the undulations of the tool surface.

4-5.1.1 The unit should fit into the space left when the placement roller is removed, so that the point of reference coincides with the central point of the tape placement path. This point is on the center of rotation of the tape placement head, "C" axis, as well as the center of rotation of the head tilt, "A" axis.

4-5.1.2. Electrical outputs from the unit's amplifiers will control the corresponding axis drives instead of the numerical control system.

4-5.2 Development Work - The major task was the development of the optical line sensing unit so that it would give outputs of both axial motion, as well as rotary, with a positional accuracy in the order of $\pm .0025$ inches. This had to be accomplished both on flat as well as curved surfaces and with varying ambient light conditions.

4-5.2.1 Closely allied to the optical line sensing system were the design parameters for the reference line tape.

Certain physical constraints dictated the final dimensions.

On compound curved surfaces, it is not possible to lay wide tapes to conform to the desired fiber orientation. For this reason the tape placement head has the slitting system to slit the tape into widths of .270 inches.

For this same reason, the width of reference tapes placed on these same surfaces must be limited to the narrow width, namely, .270 inches. Any wrinkles or unnecessary undulations in the reference tape would give erroneous outputs from the line follower unit.

4-5.2.1.1 The reference tape was designed using a white background with a black reference line.

The black line width was chosen to be .070" so that on a .270 wide tape there would be at least .10" of white background on each side of it.

4-5.2.1.2 The following is the specifications for the Digitizing Reference Tape in the 3" wide form.

The Digitizing Reference Tape is to be $3.000 \pm .005$ inch wide matte white finish lithograph stock, 3 to 5 mils thick, having a pressure sensitive adhesive backing and with a printed black line $.070 \pm .005$ inch wide centered on the paper so that the centerline of the line is coincident with the centerline of the paper to within .005. The pressure sensitive adhesive backing must be of a type which allows easy removal of the paper tape after use without damage to the surface it adheres to. The printed line shall be opaque black and of uniform density.

Figure 57 shows a reel of the 3 inch wide reference tape.

4-5.2.2 Two photo-optical sensing systems were evaluated.

- (a) A quadrant photo-cell and lense focusing system.
- (b) Two "bow-tie" shaped fiber-optic sensing devices.

4-5.2.2.1 Figure 58 shows the basic principles of the two systems.

4-5.2.2.2 Quadrant Photo Cell Sensor - The principle of this unit was to focus the image of the black reference line on to the photo cell. By looking at the outputs from the four cells differentially the displacement of the cell unit from true position along the reference line could be determined and appropriate amplified signals sent to the corresponding axes drives to correct the error.

This system required good illumination of the reference tape in order to get a clear reflected image.

4-5.2.2.3 Fiber Optic Line Sensor - In the fiber optic system, three bundles of fibers were brought to two triangular shapes, touching at the apex of the triangles. The three bundles of fibers were connected at their other ends to two photo cells and a light source. The fibers in each triangle were arranged so that there were an equal dispersion of fibers going to one of the photo-cells as well as the light source.

With the unit in contact with the reference tape, outputs from the two photo-cells were looked at differentially to give the amount of displacement from the true center of the line.

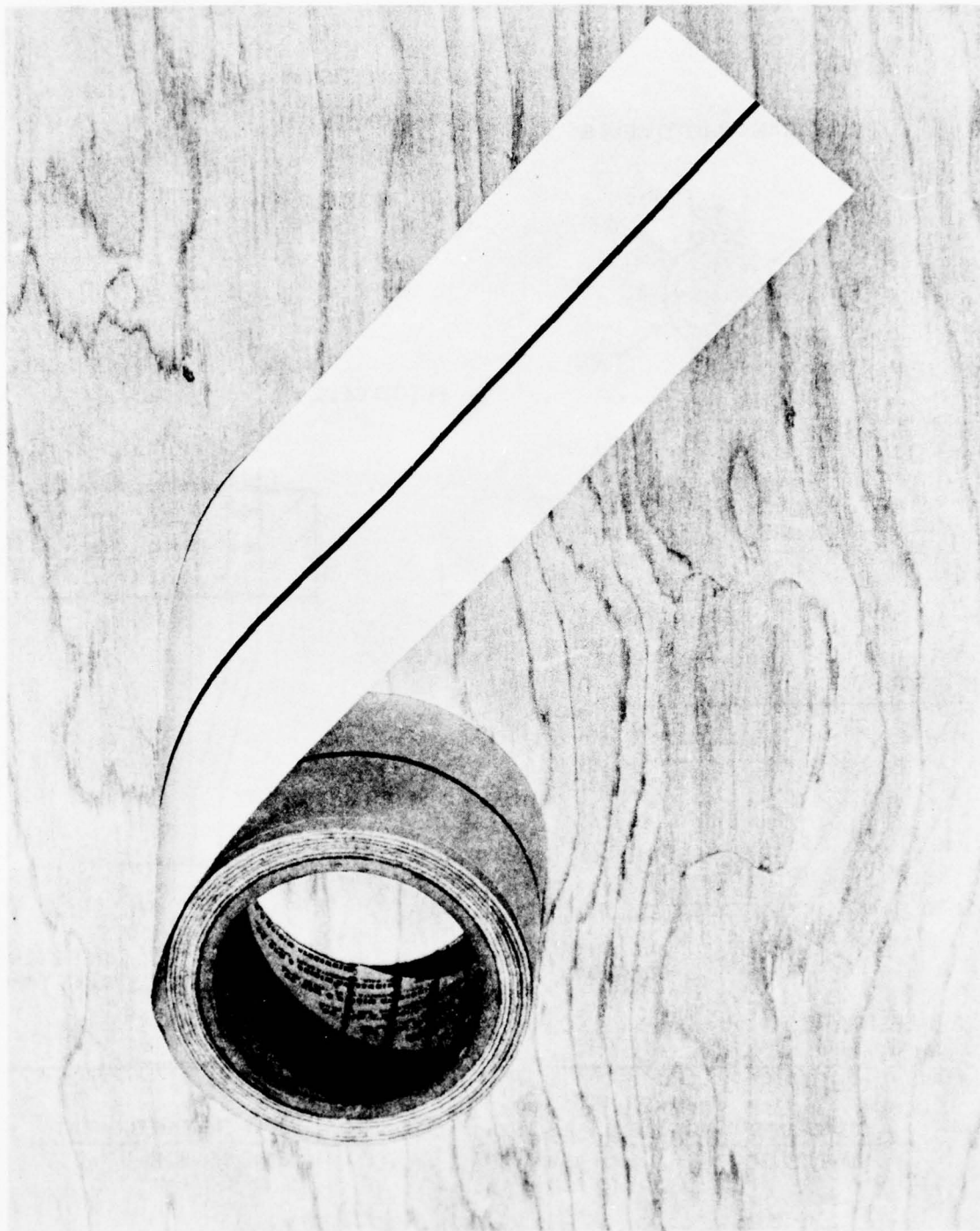

Figure 57. Reference Tape

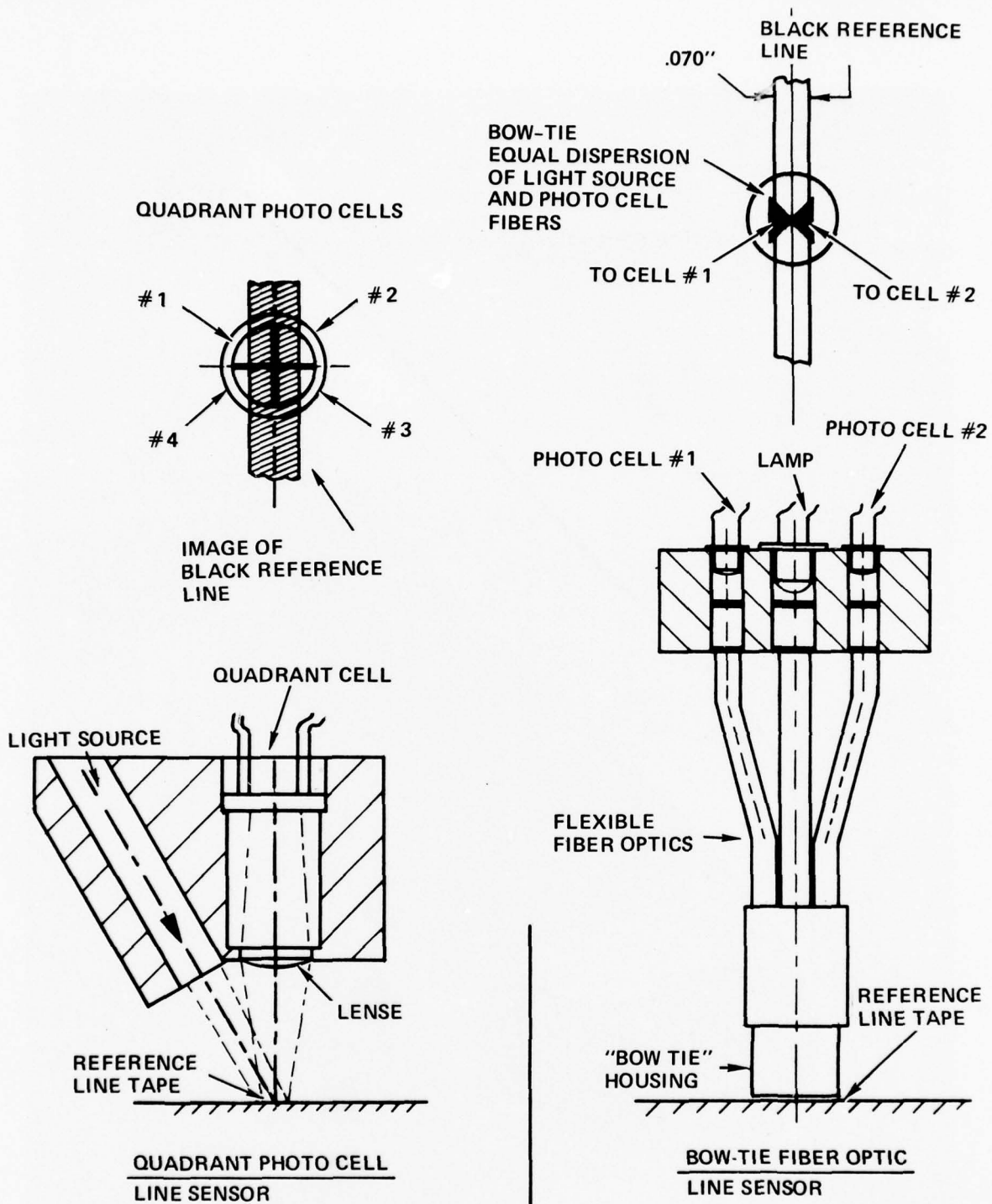

Figure 58. Line Sensing Units

One "bow-tie" unit would be sufficient to give output signals to correct for side to side errors. To get rotational sensing, two units would be needed. The X and Y signal unit would be mounted on the center line of the "C" axis rotation, and the sensor for rotational guidance would be trailing behind it at a given radius.

4-5.2.3 Tests were done to evaluate the line sensing systems, using a test rig with a micrometer adjusted movable platform, with the reference line on it.

4-5.2.3.1 Both systems were found to give sufficient output to meet the $\pm .0025$ " position tolerance.

4-5.2.3.2 It was decided to use the quadrant cell system, since the fiber-optic units would involve more mechanical motions in order to keep them in close contact at all times with the reference tape laid on compound carved surfaces.

4-5.3 Design of the Line Follower Unit - In order to give output signals to the "Z" axis and "A" axis, two mechanically compounded motions were built into the Line Follower Unit.

4-5.3.1 The photo-optic unit, and light source were mounted to a carriage which moved in an arc, with the center of the arc being the line sensing reference point. Free running wheels on either side of the unit maintain it normal to the surface at all times.

4-5.3.2 Figure 59 shows the motions of the Digitizer.

4-5.3.3 The motion giving the output signal to the Z axis, consists of pivoting the photo cell block about a neutral point to produce an up or down displacement.

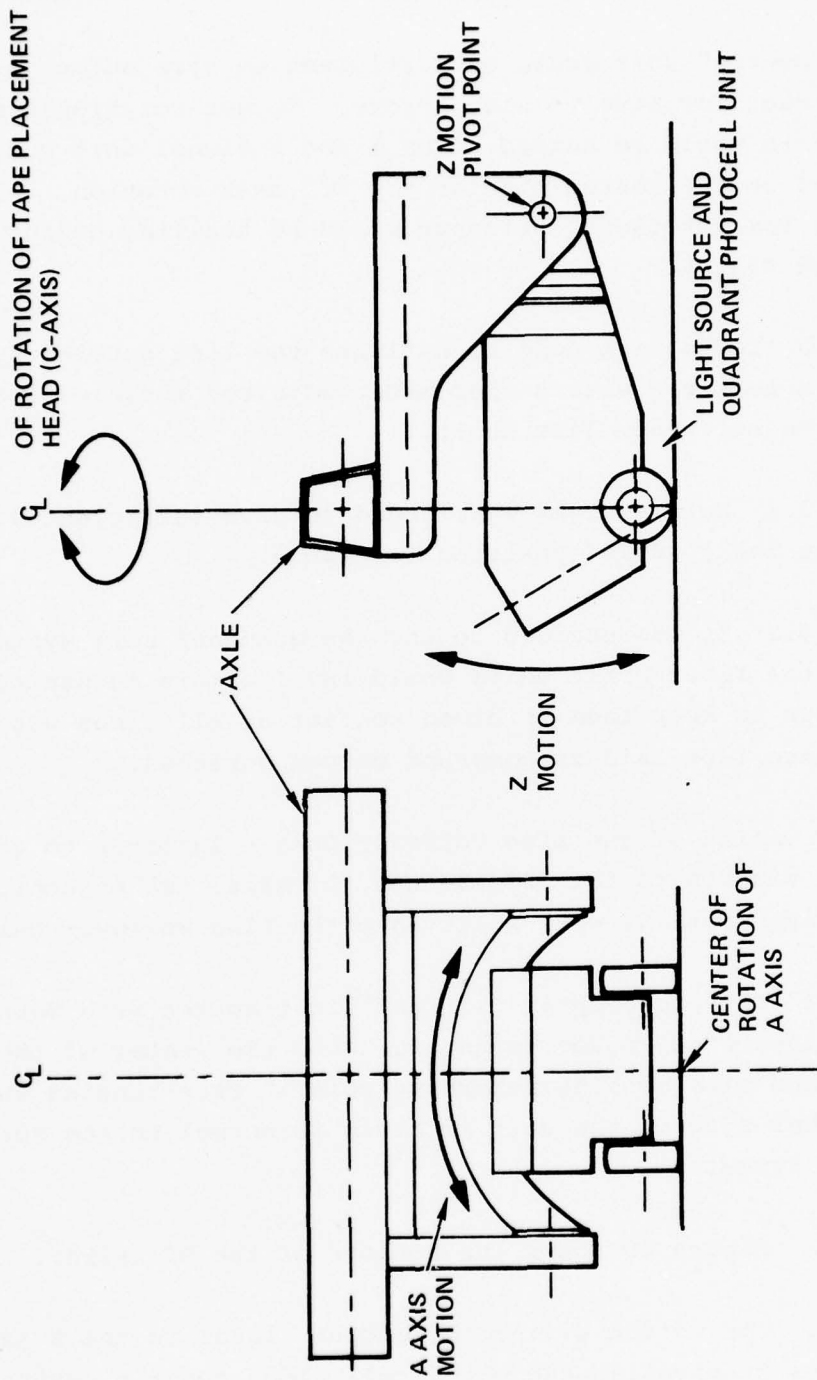

Figure 59. Line Follower Motions

4-5.3.4 Signals to the A and Z axis drives are produced similarly. Each has a pair of photo-cells receiving light from two small in-line lamps. Movement of the axis of the line follower causes one cell to receive more light and the other less. Outputs from the cells give the required direction of motion for the corrective action by the respective drive.

4-5.4 The completed line follower unit is shown in Figure 60. Also shown is the hand held control pendant used to control the machine in conjunction with the line follower unit. Figure 61 shows the unit in position under the tape placement head.

4-5.5 The Hand Held control pendant shown in Figure 62 has the following controlling functions.

4.5.5.1 E-STOP - A red momentary-on device capable of shutting off all machine power.

4.5.5.2 AXIS STOP LOCK- A blue momentary-on device used to stop and hold all machine motions.

4.5.5.3 CYCLE STOP - A yellow momentary-on device used to halt all machine motions. Note: Axis will continue to drift until the Feed Hold button is depressed.

4.5.5.4 REMOTE EXECUTE - A blue momentary-on device which, when depressed, triggers the N/C tape punch to write the position of all axes at that instant. It is used when manually digitizing.

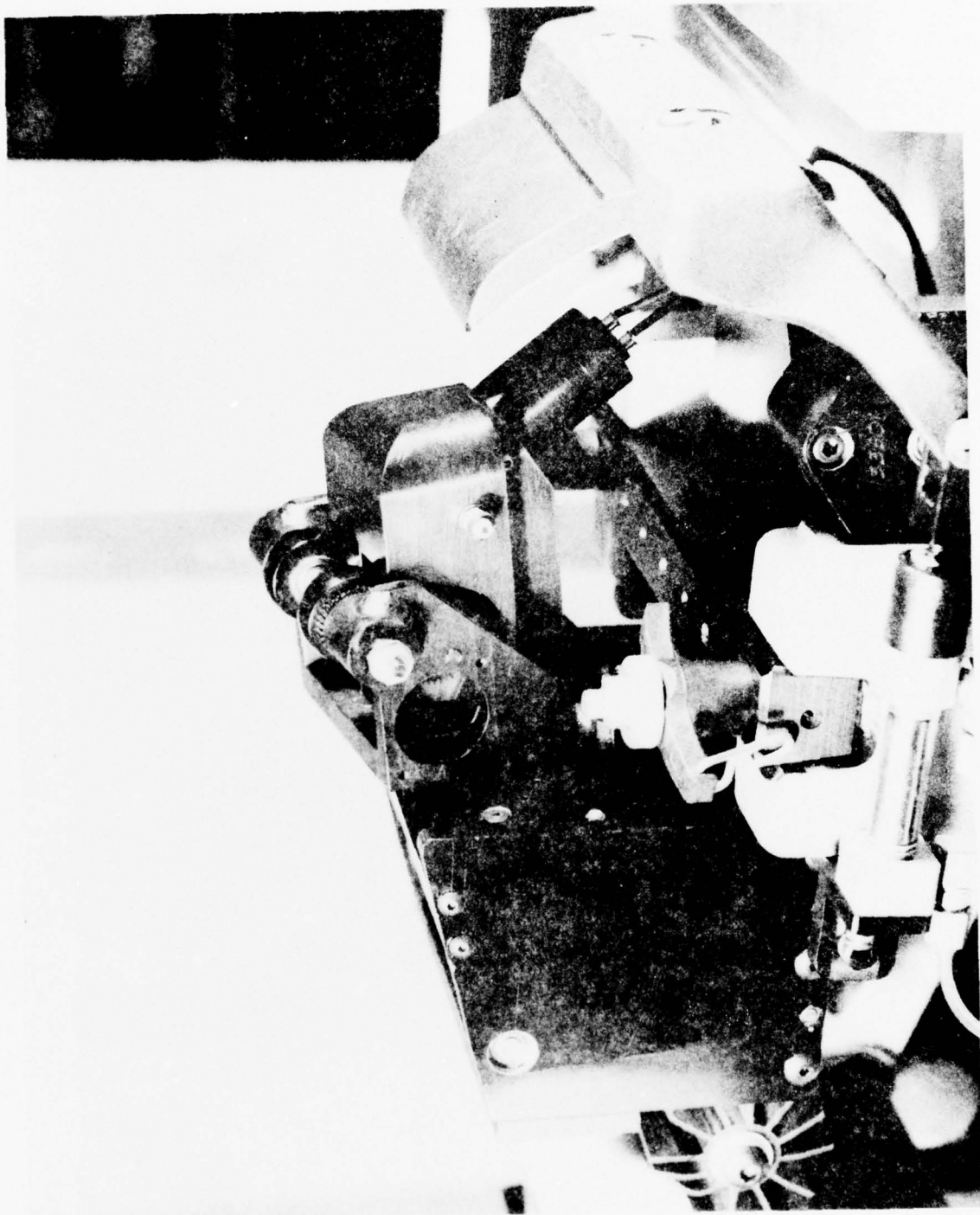

Figure 61. Line Follower Mounted Under Tape Head

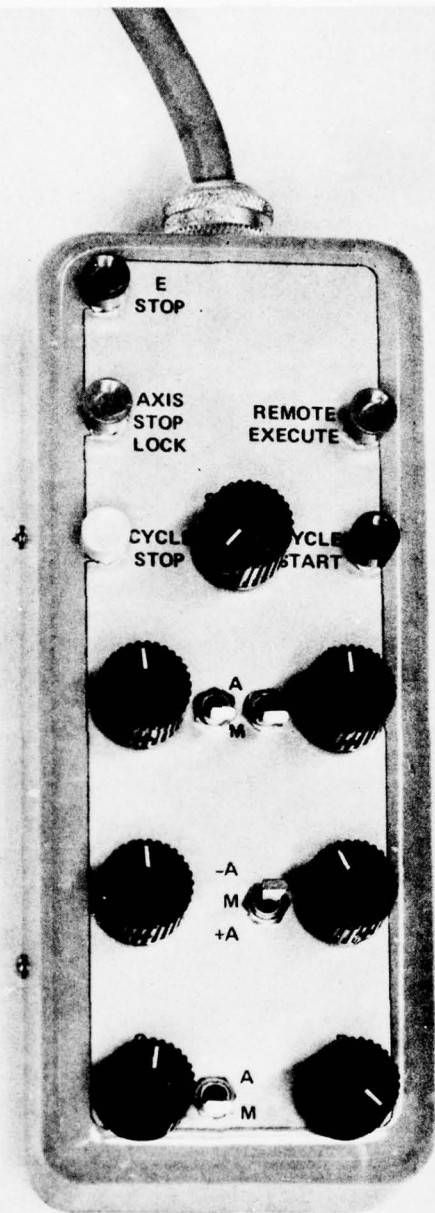

Figure 62. Remote Digitizer Panel

4.5.5.5 CYCLE START - A green momentary-on device used to initiate the movement of all axis. Prior to the control system locking on to the printed line the button must be held depressed until the two Rollers located on the underside of the line following assembly are in contact with the work piece. Once the system is enabled by the Rollers contacting the workpiece, the button may be released.

4.5.5.6 SPEED CONTROL - A rotary device which controls the velocity of the "X", "Y" and "Z" axis after the control system has been enabled by the line follower "seeing" the line.

4.5.5.7 X-AXIS - A combination of a rotary device and a lever device which provide control over the machine movements in the \pm X direction. When the lever is in the MAN position, the rotary knob can be moved in either direction away from the center position and the machine will follow at a rate commensurate with the amount of knob rotation. Clockwise motion of the knob provides + X machine movement.

Once the line following system is enabled, the lever is placed in the AUTO position, placing the X axis drive under automatic control.

4.5.5.8 Y-AXIS - A combination of a rotary device and a lever device which provide control over the machine movements in \pm Y direction. They perform identical functions as described for the X axis.

4.5.5.9 Z-AXIS - A rotary device which controls the machine movements in the \pm Z direction. Clockwise knob movement drives the machine upward at a rate commensurate with the knob rotation. Counter-clockwise movement drives the machine downward. Once the line follower Rollers contact the workpiece, the "Z" axis movement is controlled automatically by the workpiece surface.

4-5.5.10 A-AXIS - A combination of a rotary device and a lever device which provide control over the machine in the + A direction. Clockwise rotation of the knob causes clockwise rotation of the axis.

The lever has three positions. The center position provides the manual control function while the lower position provides automatic control when the tape head is pointed anywhere within the 6 o'clock to 12 o'clock quadrants, when viewed from above (+180° to +0°). The upper auto position is used when the Tape Head is pointed anywhere within the 12 o'clock to 6 o'clock quadrants (-0° to -180°).

Note: If the wrong position on the lever were to be chosen, the axis drive will receive a "hard over" signal and drive the Head to either the + or - 45° position.

4-5.5.11 C-AXIS - A rotary device which provides control of the speed and direction of rotation of the D Axis. It is used in conjunction with the Speed Control device during the digitizing operation. Basically it can be set at a convenient rotational speed and left there while the position of the other axis can be controlled with the Speed Control device, but there may be places on the workpiece where it will be desirable to manipulate the "D" Axis while varying the overall machine speed.

4-6 Steady Rests

The design, as well as the manufacture and assembly of the Steady Rests, was done during the Fabrication Phase of the ATLAS machine.

The design and description of the function of the steady rests has been covered in Section 3-8.

As the design was being done during the machine fabrication, scheduling of the fabrication of the steady rests was of importance.

In order to keep the fabrication on schedule, the design of the steady rests eliminated the requirement of any long lead delivery items, such as skew axis gears.

4-6.1 Fabrication of the steady rests was done using mostly "shelf item" components. By using a dual drive anti-backlash system, the gear box was built of standard spur gears to commercial tolerances.

4-6.2 The only major non-standard items were the two 50 inch pitch diameter gears.

4-7 Machine Assembly

This sub-section covers the assembly of the machine from the alignment of the base sections to the time of integration of the control system.

4-7.1 Base Section and Ways - The base castings were positioned and roughly aligned as each one arrived at the plant. Leveling was achieved by a number of jacking screws bearing onto steel plates placed on the floor.

4-7.1.1 The main guidance ways and drive side of the base sections were used as the datum side to obtain alignment along the base. With the base sections in position and basically aligned, the 3 inch diameter way sections and support were attached. The flat ways on the support side were also attached.

4-7.1.2 An alignment carriage, shown in Figures 63 and 64, was used to provide fine adjustments of the base and ways. A target, mounted to the carriage, was observed by an optical transit.

A maximum deviation from a straight line motor in both planes of .015" was achieved at this stage of the machine assembly.

4-7.2 Gantry and Carriages - The composite gantry was received from the fabricator without the aluminum interface plates attached.

4-7.2.1 The two cast aluminum gantry support carriages with anti-friction bearings attached were positioned on the bed ways. Rigid support was given to the carriages and adjustments made to bring their top surfaces horizontal.

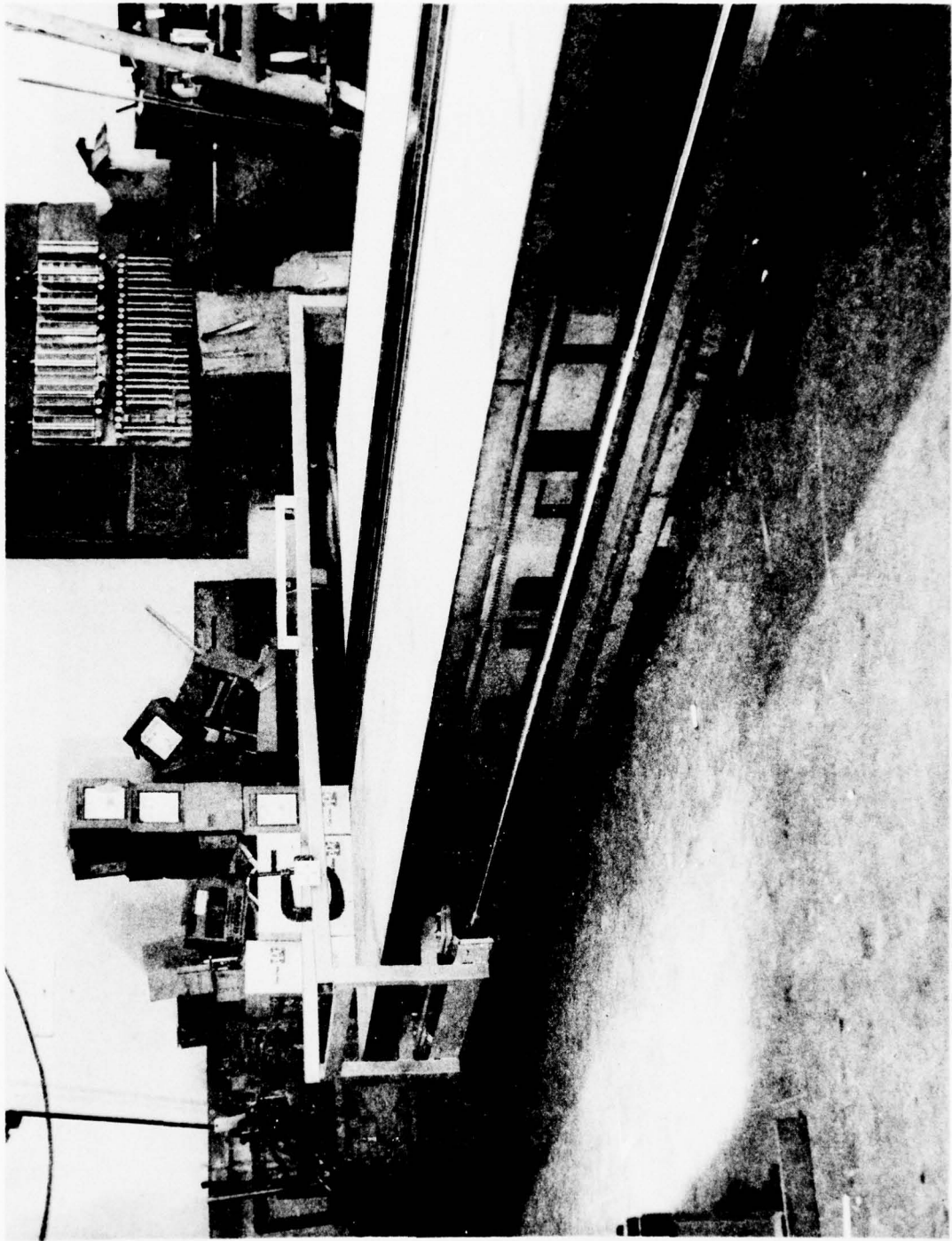

Figure 63. Alignment Carriage

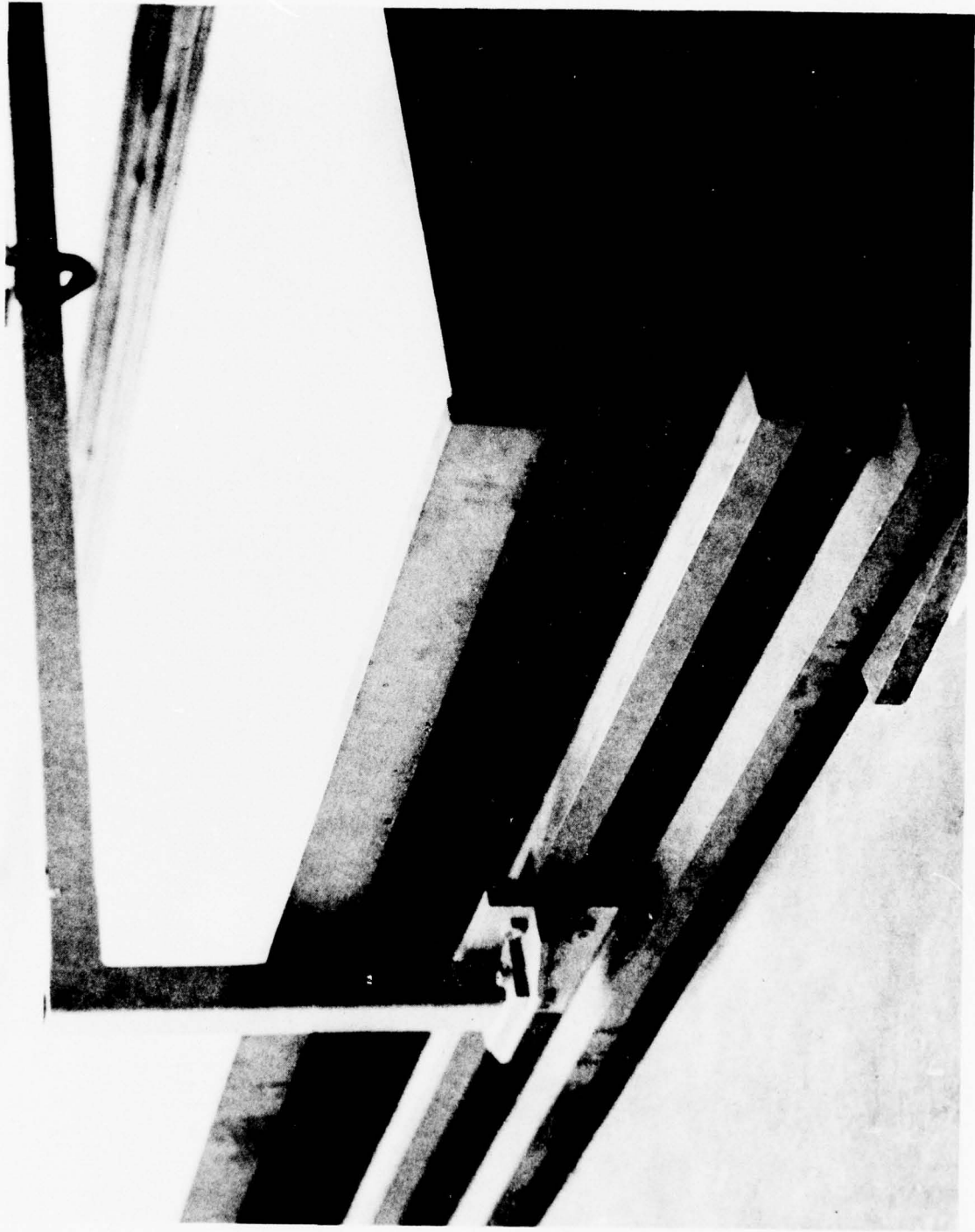

Figure 64. Alignment Carriage on Flat Ways

4-7.2.2 The under surfaces of the gantry and the aluminum interface plates were prepared for bonding.

4-7.2.3 With the interface plates positioned on top of the carriages and coated with filled epoxy adhesive, the gantry was lowered into position, creating a bond to the plates. After cure of the adhesive, all the locating and holding screws were put in place.

4-7.2.4 The gantry, on its carriages, was then mobile and was easily pushed along the ways.

4-7.3 Vertical Ways and Ballscrews - The vertical ways, ballscrew and gearbox units were positioned, and the interface plates between the two upper gearboxes and the gantry front surface bonded in position. Figures 65 and 66 show the two assemblies in position.

4-7.4 Cross Beam - The composite cross beam had been pre-assembled with the upper and lower Y axis ways mounted to it, as well as the aluminum weldments carrying the anti-friction vertical way rollers.

4-7.4.1 With the two ballscrew nuts at the same level, the beam was positioned and fastened in place.

4-7.4.2 True horizontal alignment of the Y Axis ways was achieved by adjustments of the phasing device on the cross torque tube, which changes the relationship between the two ballscrews.

4-7.5 "Y" carriage and "A" carriage assembly. The Y carriage carries the curved way and gear sector for the "A" axis carriage to ride on.

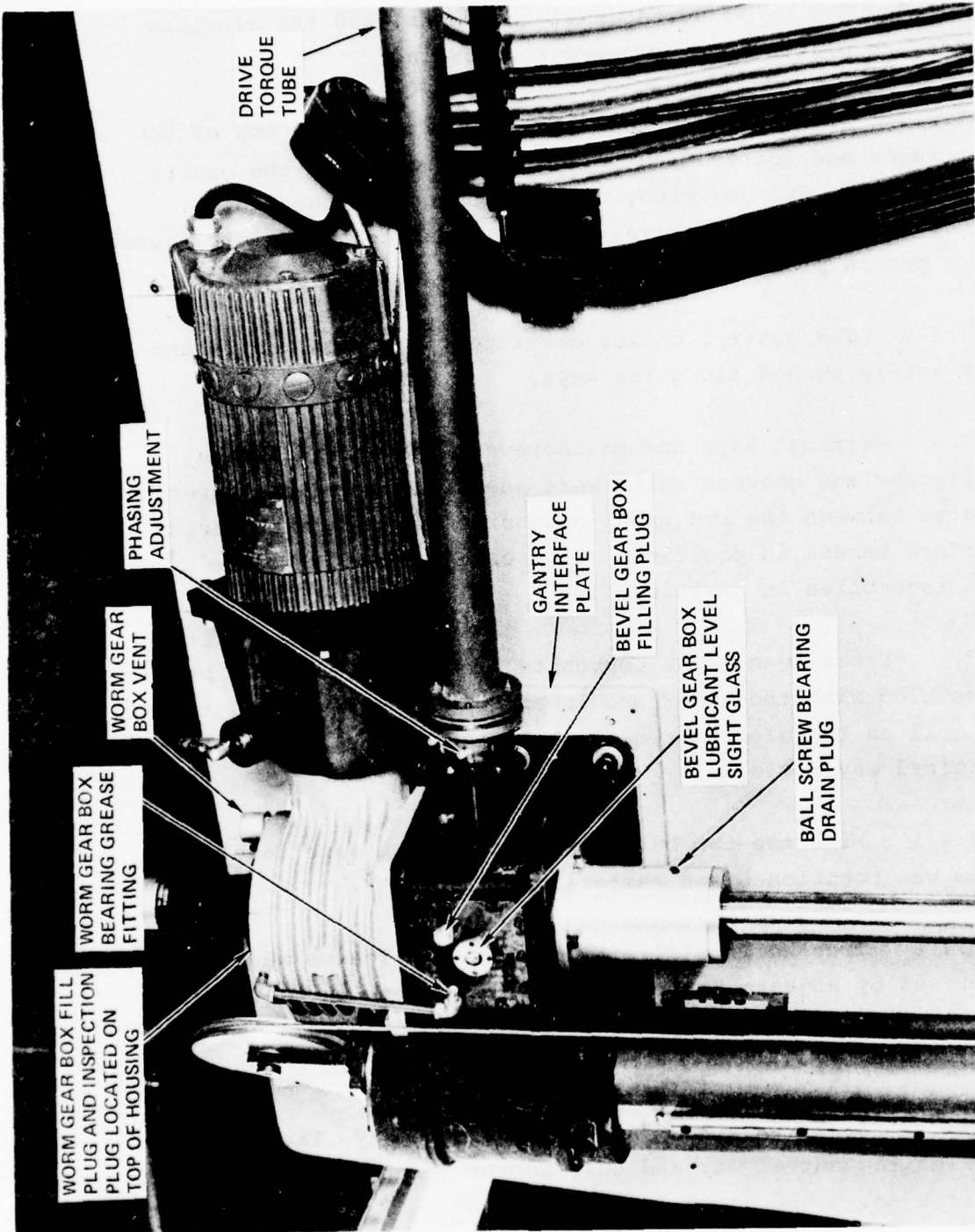

Figure 65. Z Axis - Gantry Drive Side

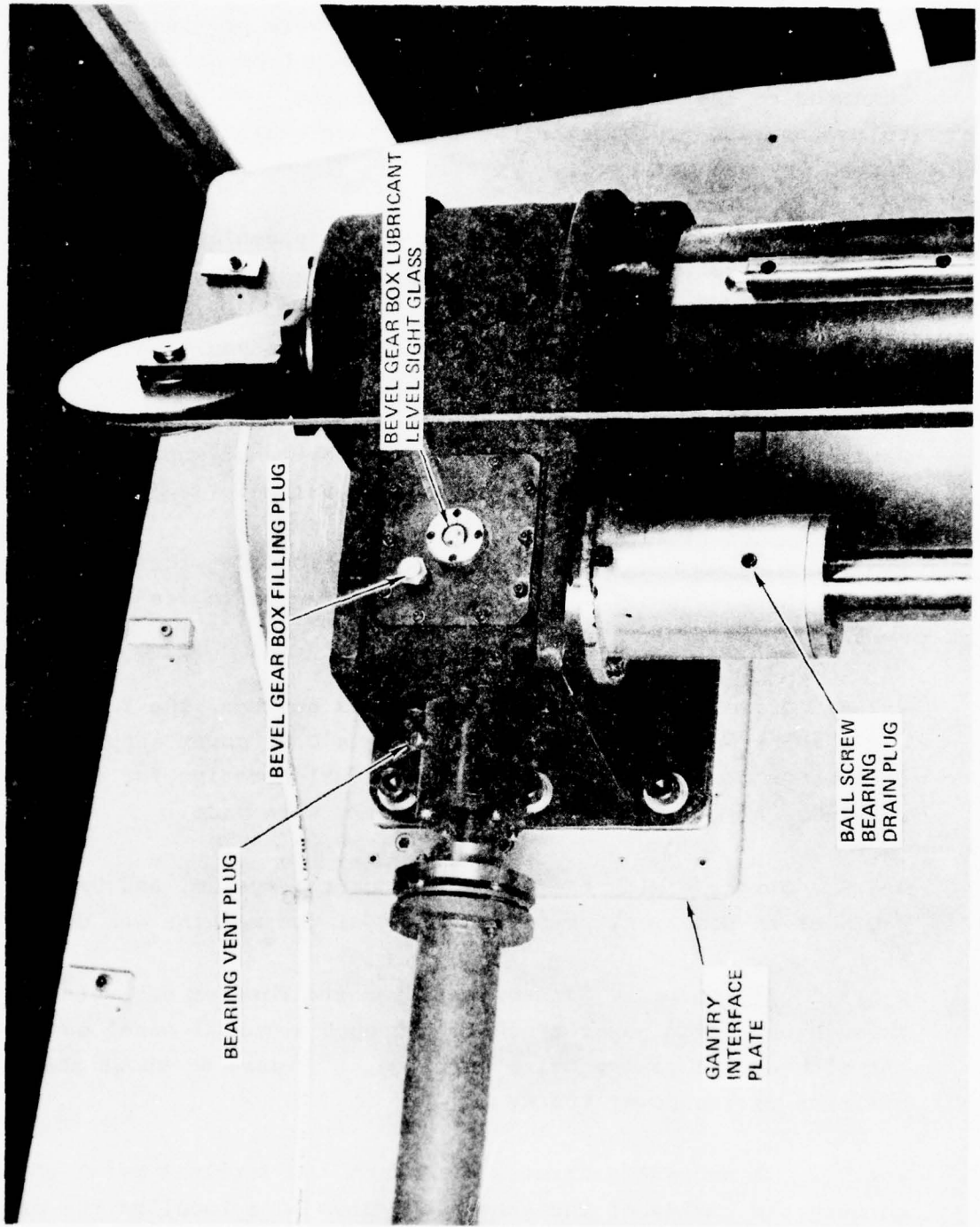

Figure 66. Z Axis - Gantry Support Side

4-7.5.1 The curved way and gear sector were pre-assembled to the Y carriage casting. A certain amount of distortion had occurred to the lower way during processing. By clamping it to the machine register on the Y carriage casting a true curved way was achieved.

4-7.5.2 The A carriage and gearbox was assembled to the Y carriage and the complete unit mounted on the cross beam.

4-7.6 Y Axis Drive Assembly - The ballscrew had been assembled to the two end bearing units as a sub-assembly. It was then positioned under the cross beam and located parallel to the Y axis motion, with the ball nut supporting bracket fastened to the rear of the Y carriage.

4-7.7 Tape Head - With the gantry positioned at the extreme end of the machine, the tape head was attached to its location on the "A" axis carriage.

4-7.8 Drive Motors - The "X" motor and gearbox, the Y motor and Z motor units were located. Using a D.C. power supply, each motor was run to check the individual motoring for free running. Also, further alignment checks were made.

4-7.9 Wiring - With the Numerical Control system, and Driver cabinets in position, complete wiring of the machine was done.

4-7.9.1 The primary harness was from the control cabinets through the large power track to a hinged terminal panel on the side of the gantry drive carriage. Figure 67 shows the position of the power track.

4-7.9.2 A secondary harness runs from the terminal panel up through the inside of the gantry and down in a loop, to the cross beam. On the cross beam, a smaller power track takes the wires to the Y carriage, as shown in Figure 68.

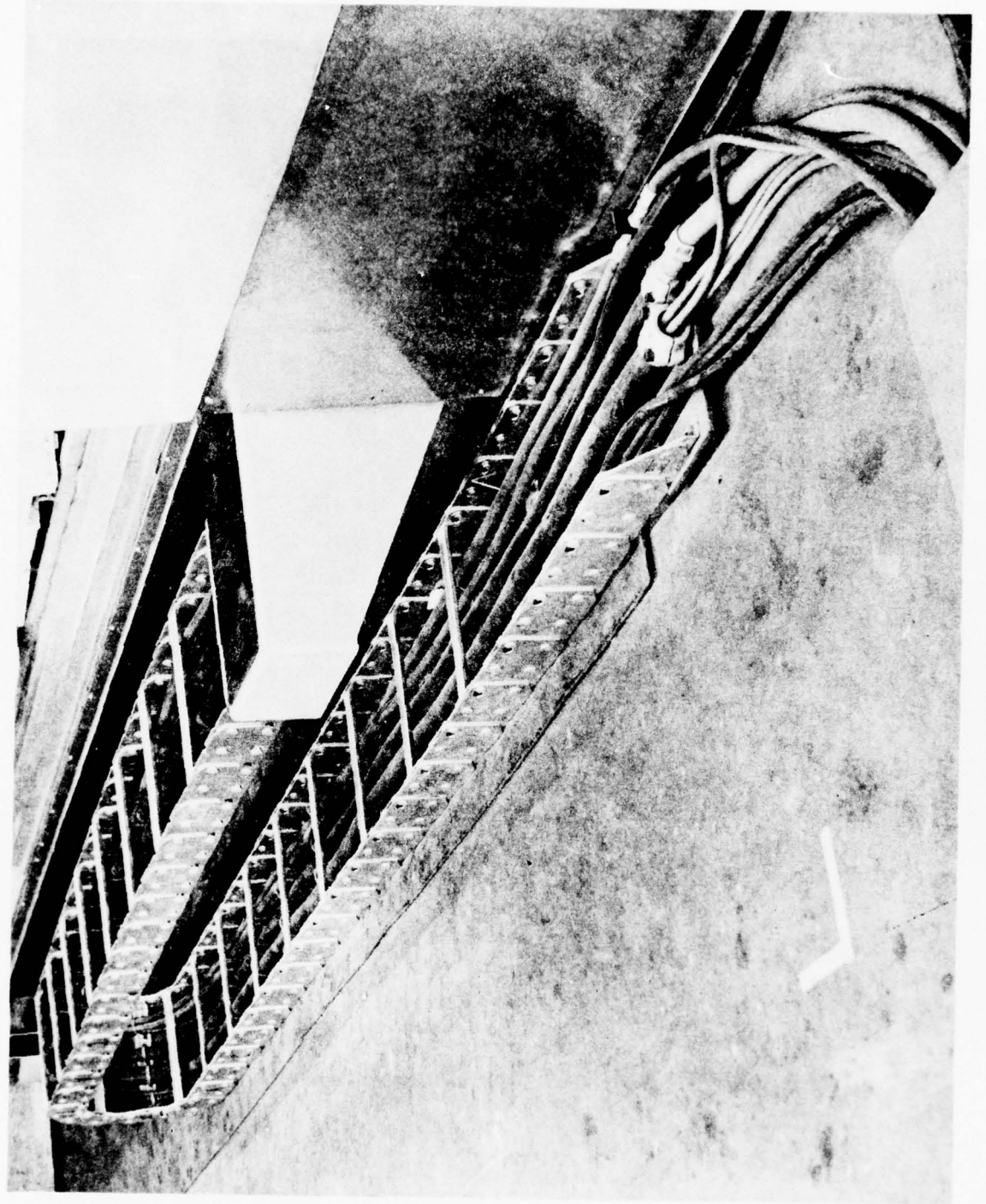

Figure 27. V. K. ...

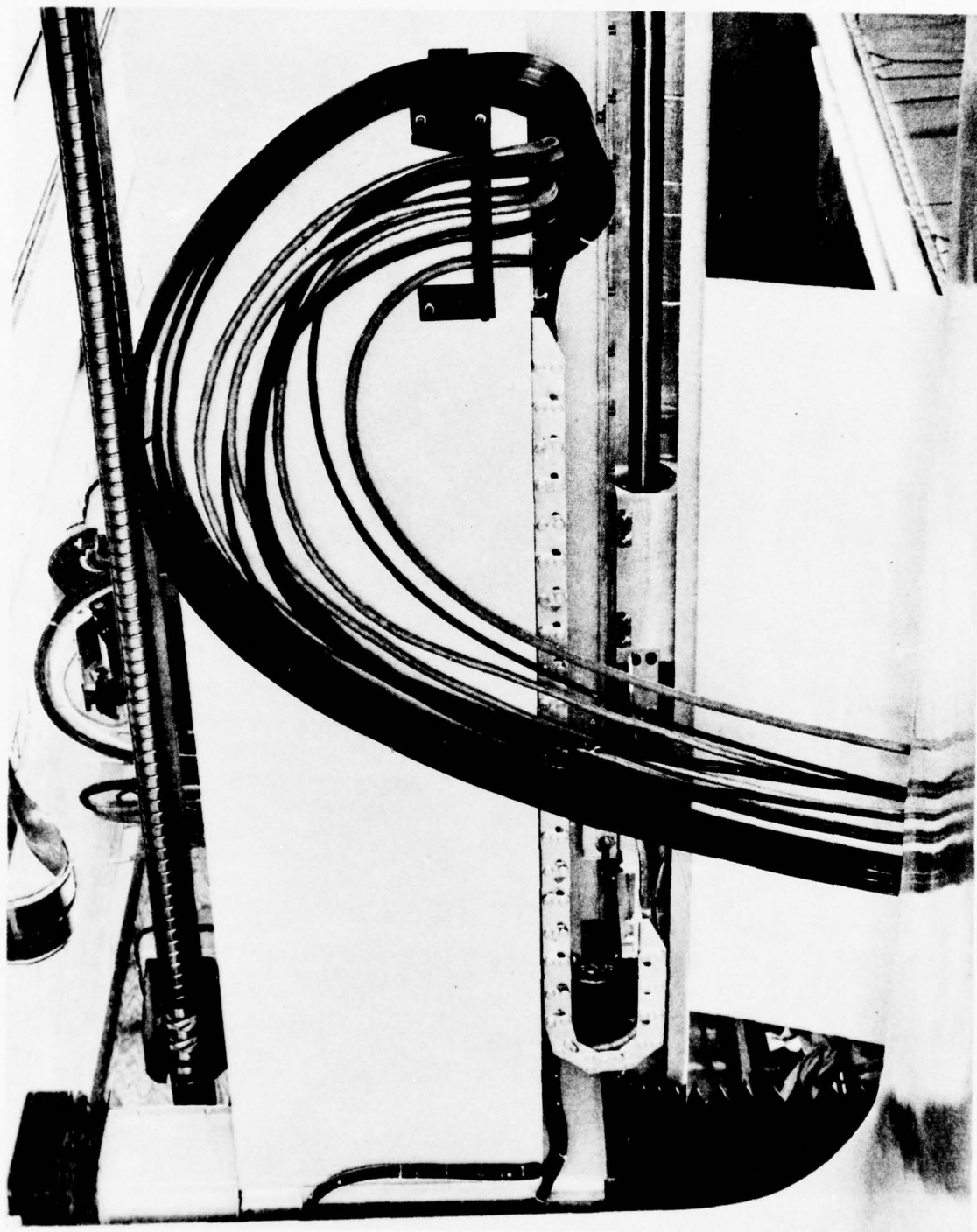

Figure 68. Y Axis Cable Track

4-7.9.3 Wires to the tape head were conducted through the upright conduit unit, which allows for the 405° of rotation required by the tape head.

4-7.9.4 Earlier problems with broken conductors in some of the moving multi-conductor cables were overcome by changing the type of wires used, and also by reducing the number of wires required by eliminating two stepper motor drives in the tape head.

4-8 Control Integration

This sub-section covers the integration of the Allen-Bradley 7300 Control to the machine.

Part of the integration work was concerned with the development of ACCEL/DECEL requirements and with the trials of the digitizing system.

Installation and set-up of the multi-axis drives are also covered.

4-8.1 Motor Drives - The two drives control cabinets contain a total of ten SCR* drive amplifiers controlling all the D.C. motors on the ATLAS machine.

Initial installation and testing of these drives was concerned with tuning them with velocity feedback only, prior to connecting the digital positioning control from the 7300 system.

4-8.2 The Allen-Bradley 7300 Numerical Control System, as described in Section 3-9, being "soft-wired" is adaptable to any type of machine and therefore relies on specific software set-up to suit a particular machine during integration.

4-8.2.1 After the control had been wired up and checked for correct connections, it was put through a number of diagnostic tests to ensure that everything within the control was functioning correctly. For example, tests for tape reader, CRT display, etc.

4-8.2.2 Following these tests, the System Tape was loaded. This system tape was made specifically for the ATLAS machine, and in its final form contains all the software information.

* SCR stands for Silicon Controlled Rectifier.

4-8.2.3 Being controlled by a computer, changes to the system are fairly easily made. With the system tape information in the core storage memory, changes to it can be made via the computer front panel buttons. The changes, or "patches" inside during the set-up, were recorded for inclusion on the next edition of the System Tape.

4-8.2.4 Each of the six machine axis was put under control in turn. Changes were made to adjust the "gain" as well as to set-up the maximum speed of each axis to its correct value.

4-8.2.5 Initially the X and Y axis had been set-up to have four (4) servo bits for each increment of resolution (.001"). When running the machine in tests, it was found that the acceleration and deceleration was too abrupt. The "following error" on X and Y axes had been extended to the maximum capacity of the system. In order to double the "following error", the servo bit was changed to two (2) for each increment of resolution.

4-8.2.6 The start and stop characteristics were still not smooth enough, with the extended "following error" showing the need for a controlled acceleration and deceleration. Further information on this is in 4-8.3

4-8.2.7 The ability of changing various characteristics of the control by "patching" into the computer proved to be a useful feature. However, time was lost due to sudden, unexplained, loss of system software within the computer. Overheating in the control due to lack of an air conditioning system caused a number of components to function incorrectly. An air conditioning system was fitted to rectify this.

4-8.3 Acceleration/Deceleration - The need for controlled acceleration and deceleration of the prime axes (X and Y) of the machine had been anticipated during the preceding design contract. Since the machine elements were designed to be lighter in weight and less stiff than normal N.C. machine tools, a lower natural frequency was expected.

More important was the detrimental effect on the tape laying system caused by sudden acceleration. Good adhesion of the composite tape to the tool surface is essential, particularly at the start of a lay down pass. The tape has to reel off the large pay-off spool and therefore transmits forces needed to accelerate the spool rotation.

4-8.3.1 Even with the increased servo bit size and maximum extended following error, the accelerator characteristic of the X axis, in particular, was too abrupt. By looking at the velocity trace produced by the output from the tach. generator on the "X" axis motor, the shape of the acceleration curve was observed. Figure 69 (a) shows, typically, the velocity trace obtained. The sharp change at the beginning of the move is the undesirable feature.

4-8.3.2 A preferred velocity trace is shown in Figure 69 (b). This was the type of acceleration required with a steady constant motion.

4-8.3.3 Acceleration/Deceleration Software - Development of the Acceleration/Deceleration Software was done by the control manufacturer Allen-Bradley Company.

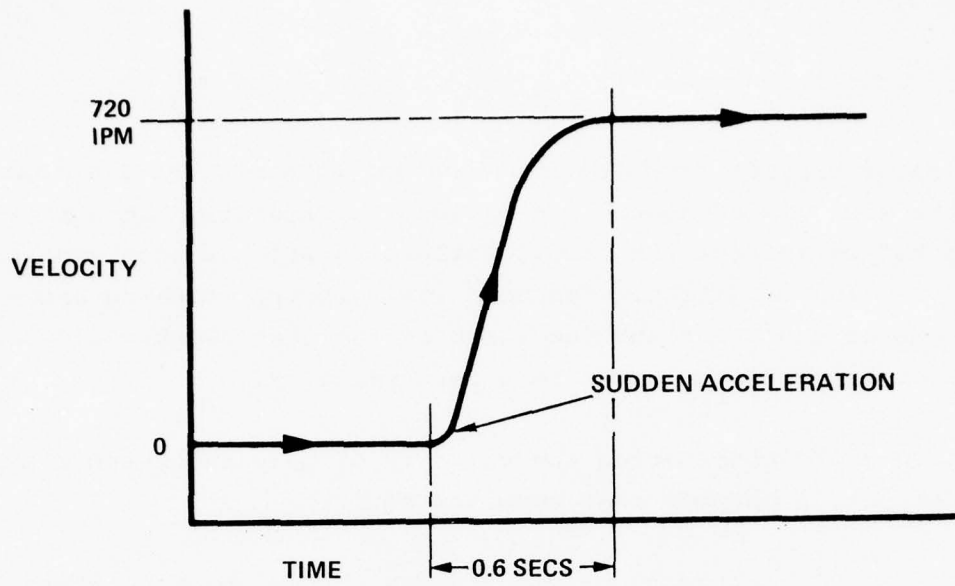

(a) VELOCITY TRACE X AXIS WITHOUT ACCEL. CONTROL

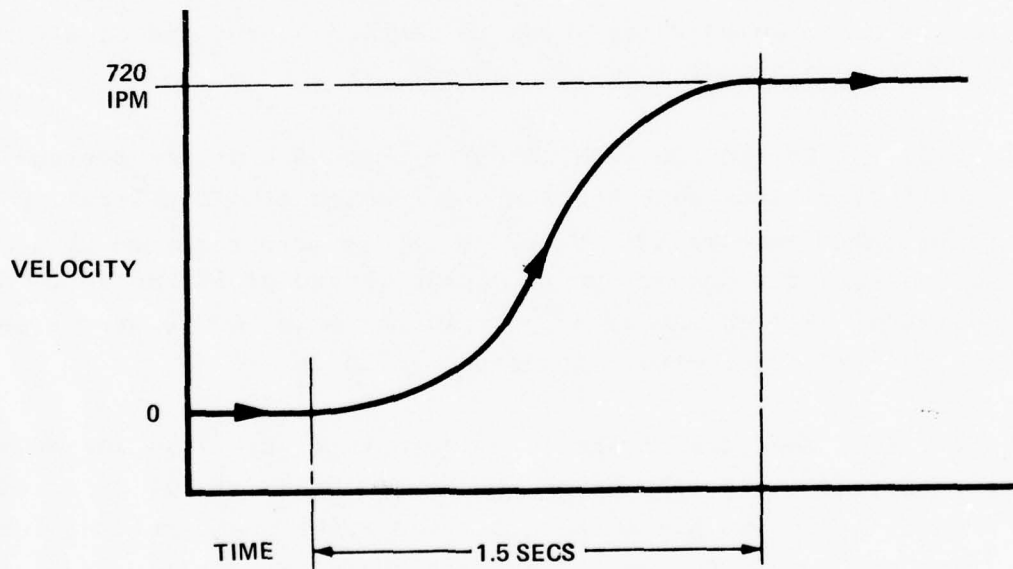

(b) PREFERRED VELOCITY TRACE X AXIS

Figure 69. Acceleration Curves

The major problem in developing the software was the complexity of the six axis of controlled motion, particularly where short "blocks" of information occur, coinciding with an acceleration or deceleration condition. The need for velocity matching between the end of one block and the start of the next block would result in some axis being brought to a zero velocity.

4-8.3.3.2 By considering the velocity of only the X and Y axis, the situation becomes less complicated.

4-8.3.3.3 The software produced gives acceleration/deceleration whenever there is a controlled move, with the control in automatic or keyboard mode.

4-8.3.3.4 There are two variables which can be changed in the computer. One is the acceleration/deceleration rate and the other is the creep speed rate, which is reached at the end of a deceleration before dropping to zero speed.

4-8.3.4 During the final machine check out at the Boeing-Vertol facility, various settings for the Acceleration/Deceleration and creep speed were tried. Velocity traces were recorded on a hot pen chart recorder run at a paper speed of 100 mm/sec. A series of 30 inch moves, in positioning mode (GCO), were programmed for the "X" axis, with a feedrate of 720 ipm.

4-8.3.4.1 The final traces are shown in Figure 70. The acceleration and the deceleration both show a time of 1.7 secs. to go from 0 to 720 ipm and back to 0. The creep speed setting for this final set up was 60 ipm. The trace shows it occurring for a very short time.

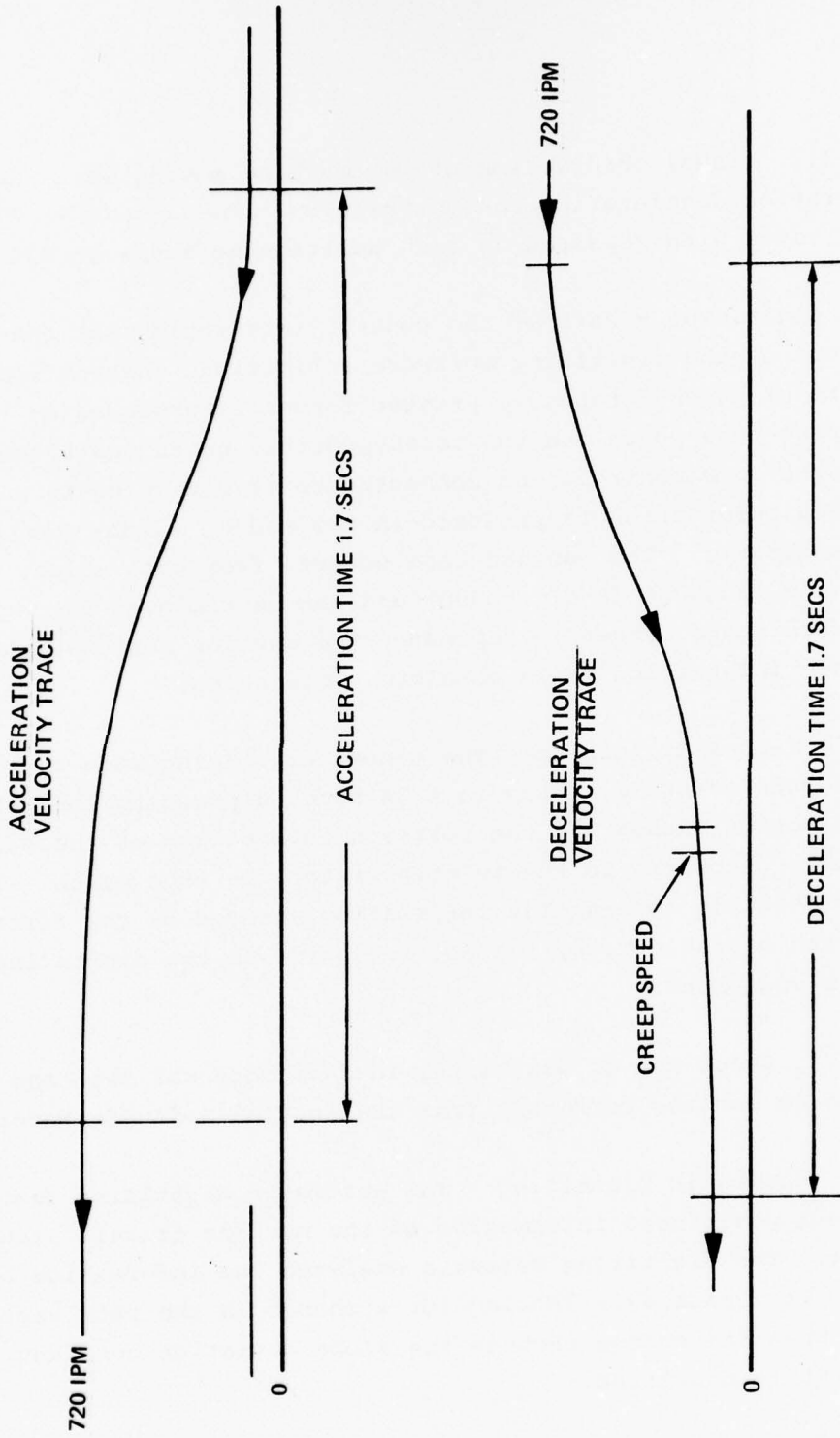

Figure 70. X Axis Acceleration Velocity Traces

4.8.3.4.2 Visual observation of the machine moving with these acceleration/deceleration characteristics show them to be very smooth, even with repeated 30 inch positioning moves at 720 ipm.

4.8.4 Digitizing - Part of the control integration was the check out of the digitizing software. Digitized information in the form of punched tape and printed format is produced on the high speed tape punch and the teletypewriter units positioned beside the 7300 control, and connected to it with plug-in cables. Digitized information is produced in two modes, either manually or in automatic. The punched tape output, from both modes, is in machine language (ASCII coded) and can be replayed through the control tape reader to reproduce the machine motions. All digitized information is in absolute coordinates.

4.8.4.1 Manual Digitizing - The manual digitizing mode does not require much software. When in this mode, depressing the Manual Execute button causes all the position information of the six axis to be outputted to the teletypewriter, or tape punch. It is also possible to transfer information entered on the first four lines of the CRT, by the MDI keyboard, to the digitizing hardware equipment.

4.8.4.1.1 Check out of digitizing in this mode was done and found to be working correctly from the initial software received.

4.8.4.2 Automatic Digitizing - The automatic digitizing feature prints out positional information as the machine travels along the part. The digitizing software analyzes the information being received from each axis looking for a change in the path vector slope. When the change exceeds the slope deviation constant, that point is digitized.

4-8.4.2.1. Before starting to digitize, the slope deviation constant is manually entered by the keyboard and is displayed on the CRT.

4-8.4.2.2 The basic principle of this slope deviation computation is shown in Figure 71.

4-8.4.2.3 Considering just two axis, X and Y and their moves from $X_1 Y_1$ to $X_2 Y_2$ and then to $X_3 Y_3$. The computer calculates the deviation which is the height of the triangle formed by $X_1 Y_1$ and $X_2 Y_2$ and $X_3 Y_3$, and if it is greater than the preset amount causes the point $X_3 Y_3$ to be digitized. This basic calculation is done by looking at every combination of pairs of axis of the machine.

4-8.4.2.4 To check the performance of the automatic digitizing, a pen trace technique was used. A ball point pen, spring loaded vertically, was mounted in the placement roller location under the tape head.

The machine axis (X, Y and Z) were put under control from the line follower manual control box and a random trace done on a board placed on the table surface. Punched digitized tape was produced by the tape punch during the trace.

4-8.4.2.5 The machine was put back under numerical control and the digitized tape fed into the tape reader. Exact reproduction of the original trace was achieved, within the limits of the ball point pen system.

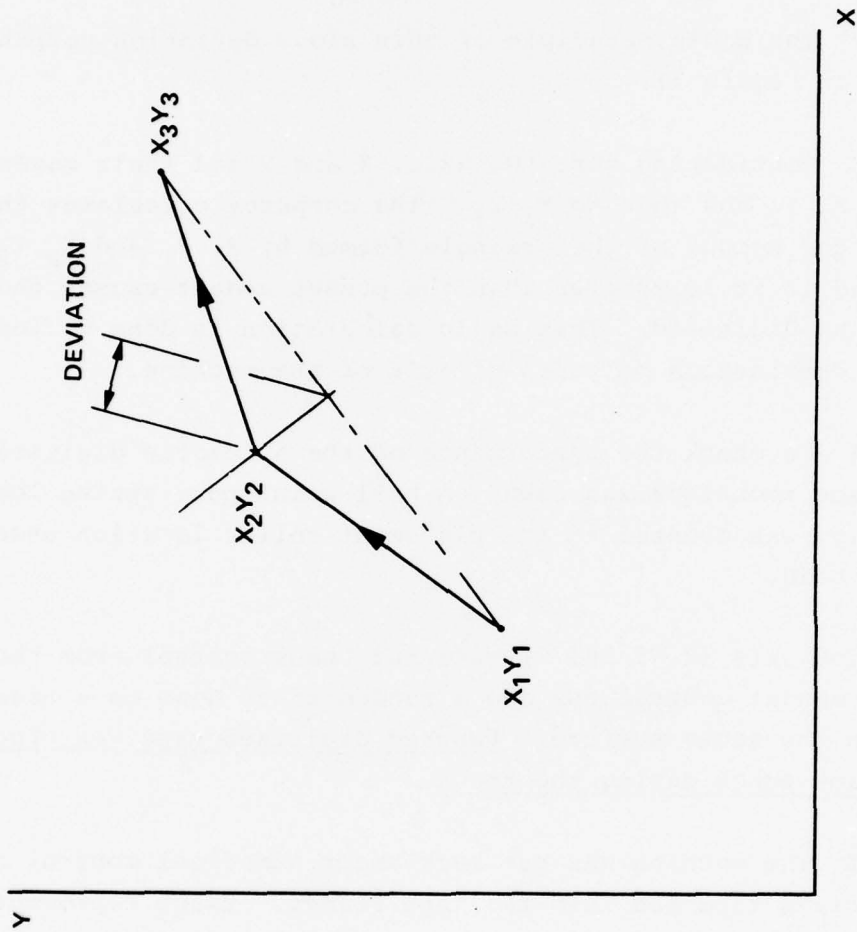

Figure 71. Digitizing Slope Deviation

4-9 Tests and Demonstrations

It had been the original intention to have the machine in a completely developed and tested condition, able to meet the requirements of the Plan of Performance Test Plan. (Appendix III), during this Phase of the Contract.

A number of continuing malfunctions, primarily in the control system, delayed the schedule, and shortened the amount of development work done at this time. This section of the Report covers testing and demonstration work done at the Contractors facility.

4-9.1 Machine Motion Checks - The first tests done to check the performance of the machine's coordinated motions, were done by pen traces. These would show the interpolation ability and repeatability of the X and Y axis.

4-9.1.1 A ball point pen mounted vertically under the tape placement head was used to do a number of programmed traces on a piece of flat board positioned on the table of the machine.

4-9.1.2 The program was written to test the repeatability of the X and Y axes as well as accuracy of interpolation. Figure 72 shows the programmed pattern.

4-9.1.3 The angled lines were designed to show the straight line interpolation of the X and Y axis. The two circles demonstrate the circular interpolation as well as any lost motion in the machine drives at the reversal points.

4-9.1.4 Results showed that the machine and control were working within the specified tolerances. True circular traces, with no flat spots at the four quadrant points, showed the interpolation and drives to be working correctly. A repeated run showed that repeatability was like the resolution of the pen trace, in the order of $\pm .005$ ".

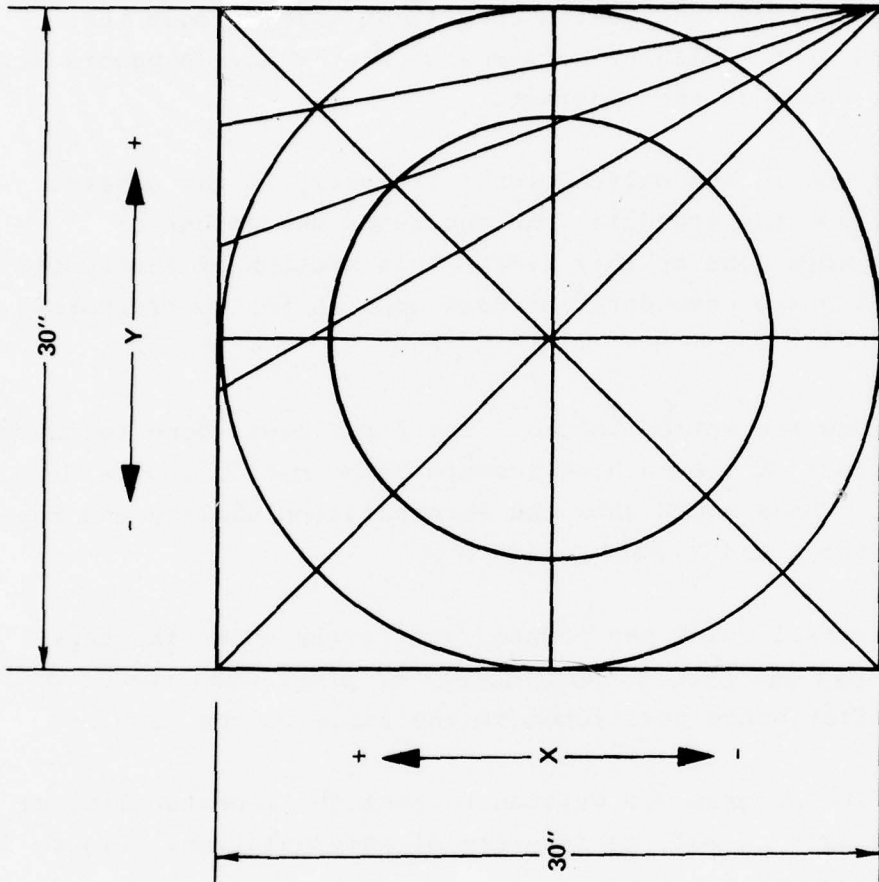

Figure 72. Typical X, Y Axes Pen Trace Test

4-9.1.5 Traces were run at a speed of 100 ipm. With further runs done at 150 and 200 ipm, the traces of the circular shapes reduced in diameter, due to the "following error" inherent in servo driven equipment. Repeatability and dimensions of the straight line traces were not affected by the higher speeds.

4-9.1.6 This type of pen trace system was used to demonstrate the basic capabilities of the machine to do coordinated, accurate motions.

4-9.2 Flat Pattern Layup - The first task in the flat pattern layup program was to establish the exact "cut-off" length. This is the distance travelled by the placement unit from the position where it stops to do the shearing operation, to the end of a laydown pass. This distance has to correspond to the length of tape from the point of shearing to the centerline contact point under the placement roller. Inaccuracy of "cut-off" length becomes easily visible when one pass is completed and the head rotated 180° and a return pass made. The two ends of the passes will not be level if the "cut-off" length programmed is too long or too short.

4-9.2.1 By making successive adjustments to the program, a "cut-off" length was established for the placement roller set-up. The allowable tolerance on a laid tape length is $\pm .060$. This gives an allowable tolerance at the end of $\pm .030$, assuming the machine axes move accurately measured distances.

4-9.2.2 With the "cut-off" length established the program for the flat pattern performance test (Appendix III) was written.

The purpose of this pattern was to demonstrate flat layup in the X and Y directions, as well as 45° passes. The performance of the shear on the 45° passes could also be evaluated. The program was written to produce a no-overlap condition on side by side passes with 3 inch wide tape.

4-9.2.3 Due to a number of factors, this layup pattern was not successfully demonstrated during this phase of the program. Problems with the condition of the glass epoxy tapes, and the run-out of the surface of the inflatable placement roller made the laying of long (120 inches) straight passes to a reasonable degree of accuracy difficult to achieve.

4-9.2.4 Fuller investigation of lay-up on flat surfaces was done during the next Phase of the Contract, at the Boeing-Vertol facility, and is covered in Section 5-3.

4-9.3 Root End Mock-up - Part of the final performance test was the demonstration of the machine's ability to do a series of lay-up wraps on the root end mock-up of a helicopter blade spar.

4-9.3.1 This mock-up, shown in Figure 73 in a supporting stand, was made up from aluminum templates and faired in with plaster. To prevent the surface plaster from cracking, a skin of glass fiber cloth was put over the mock-up.

4-9.3.2 Test 2 of the Performance Test Plan (Appendix III) outlines the type of wraps to be done on the mock-up.

4-9.3.3 Development of the program for one of these wraps was done by digitizing techniques as described in Section 4.5 from reference tape hand laid on the surface in the desired path.

4-9.3.4 Lay-up of tape on this programmed path was not demonstrated at this time. The coordinated six axis machine motions required to follow the programmed path were demonstrated.

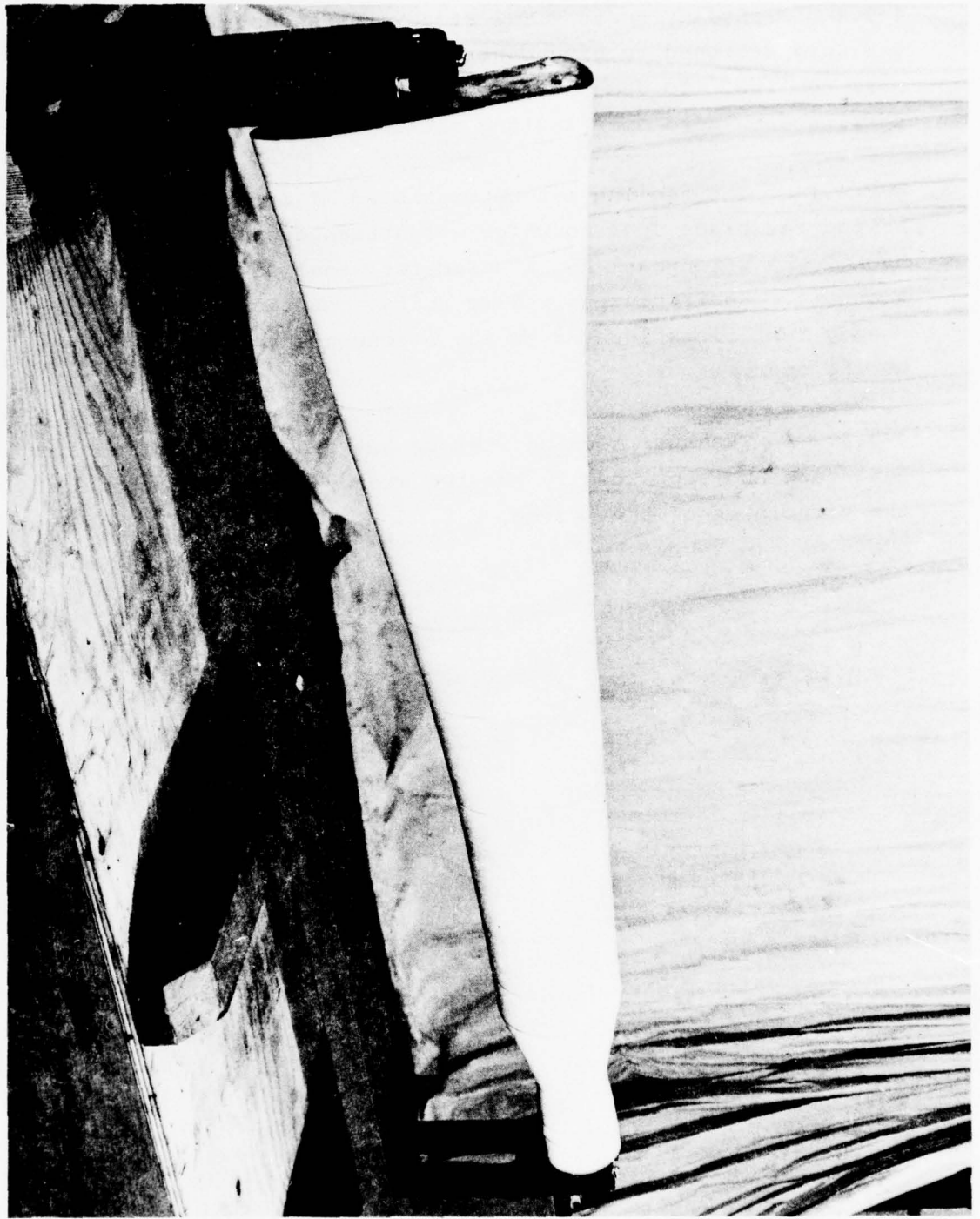

4-9.4 Steady Rests - The steady rests described in Section 3-8 were designed to give controlled support to helicopter blade spar tooling. To demonstrate their function and ability to do this, a simulated spar tooling set-up was made.

4-9.4.1 The tooling set-up consisted of an alloy steel helicopter blade spar to which was attached an aluminum strongback. The strongback had 1" diameter steel way strips mounted along it. Recirculating roller units, mounted within the two steady rest rings located on the strongback ways, gave support to the spar.

4-9.4.2 The spar tooling, set-up between the headstock and tailstock and supported by the two steady rests, demonstrated the principles of the system.

4-10 Shipping

The disassembly of the ATLAS machine marked the end of the Fabrication phase of the Contract at the Contractor's facility.

4-10.1 The machine was broken down into units small enough to be loaded on to trucks for shipment to Philadelphia.

4-10.2 The Allen-Bradley 7300 control unit was shipped to their facility for complete testing, prior to sending on to Boeing-Vertol.

4-10.3 Table 4 gives the shipping configuration for the component subassemblies.

SHIPPING CONFIGURATION FOR COMPONENT SUBASSEMBLIES

TABLE 4

DESCRIPTION	QTY.	WEIGHT (LBS. EA.)	APPROX. SIZE (INCHES)
Bed and Table Top	8	9,000	16 x 53 x 168
Rectangular Way	7	235	1.5 x 5.5 x 96
Round Way	4	510	3 dia. x 168
Gear Rack	14	65	1.5 x 3 x 48
Head Stock	1	1,500	24 x 45 x 46
Tail Stock	1	1,500	24 x 45 x 46
Gantry	1	1,505	94 x 102 x 164
X-Axis Drive Carriage	1	1,110	20 x 21 x 108
X-Axis Support Carriage	1	345	16 x 21 x 40
Y-Axis Assembly	1	1,690	26 x 48 x 198
Z-Axis Drive Assembly	2	450	12 x 12 x 90
Tape Head Assembly	1	900	24 x 24 x 60
Gantry Cover	1	100	14 x 24 x 160
Motor Control Center	2	3,000	36 x 72 x 84
Control Console	1	1,200	30 x 52 x 72
Steady Rests	2	1,500	60 x 60 x 30

Crates containing attaching hardware and miscellaneous small parts.

SECTION V
INSTALLATION OF ATLAS
AT BOEING-VERTOL

SECTION V

INSTALLATION OF ATLAS AT BOEING-VERTOL

This section covers the final installation of ATLAS at the Boeing-Vertol Company facility, from the initial setup through to the successful demonstration and acceptance. Development work on placement units and details of programming techniques are also contained in this section.

5-1 Installation

The machine, shipped by trucks from the Contractor's facility, was re-assembled in the Boeing-Vertol plant. Re-assembly followed similar procedures to the original assembly. (covered in Section 4).

Base sections were positioned and leveled on steel pads placed on the floor. No special foundations were provided.

Final alignment checks and adjustments were made after the control system had been installed.

5.1.1 The Allen-Bradley 7300 Numerical Control unit, which had been shipped via the vendors facility for complete check-out, was installed and wired to the machine. Complete check-out was done after installation and before controlling any of the machine axes. The diagnostic routines confirmed that everything was working satisfactorily.

5.1.1.1 Setting of the following error for the machine axes was facilitated by the use of a program manually entered into the control computer. This program displayed the "following error" of the axis under control on the CRT. By programming the axis to run at maximum velocity, the "following error" was displayed

allowing accurate tuning of the axis to bring the "following error" to the desired value. When stationary, the number displayed represented the "standing error". This allowed balance adjustments of the drives to be optimized.

5-1.1.2 Tuning of the Rotary Inductosyn Scale wave form was assisted by a routine entered into the computer.

The rotary inductosyn scale is the feed back device mounted on the Headstock for the "D" axis motion.

5-1.1.2.1 Alignment of the rotating scale with respect to the fixed scale is critical for both concentricity and air gap. It was discovered that excessive loading on the headstock chuck would cause the rotating scale to tilt. By mechanically adjusting the scales and optimizing the waveforms being generated, the "D" axis was set-up.

5-1.1.3 Part of the final set-up was the optimization of the Acceleration/Deceleration characteristics for the X and Y axis. Velocity traces done on a chart recorder provided the information required to select the desired rates and creep speed settings. The Accelerator/Decelerator finally set-up is shown in Figure 70.

5-1.1.4 The digitizing software performance was checked in both manual and automatic modes.

5-1.1.4.1 In automatic mode, a random shape per trace was done by moving the X and Y axis under manual control from the line follower hand held control box.

The punched tape was re-played to give a precise reproduction of the original trace.

5-1.1.4.2 To check the mirror image feature of the control, the same program was run through four times.

- a) with X and Y in normal setting
- b) with X reversed
- c) with only Y reversed
- d) with X and Y reversed

The resulting trace showed the pattern to be accurately produced in the four quadrant images.

The machine axis alignment checks and repeatability tests are outlined in the coordinated test plan in Appendix III. The test plan formed the basis for the checks done during the installation at the Boeing-Vertol facility.

In the Repeatability tests, the major interest was in the performance of the composite gantry structure relative to positional repeatability in the X axis direction.

5-2.1 Motion in the "X" direction - A precision transit was used to sight a target scale mounted on the tape head.

The gantry was moved in 4 ft. increments. A series of readings were taken showing side to side deviations of motion of the gantry along its supporting and guiding way.

Results are shown in Table 5 (a).

5-2.2 Vertical Alignments in "X" Direction -A precision transit was used to sight a target scale mounted on the tape head, to look at vertical deviations in motion when the gantry was moved in 4 ft. increments.

The resulting readings are shown in Table 5 (b).

(a) Horizontal Deviations 

Gantry Position		Deviation in
Distance in feet		.001" increments
X	0 Home Position	0
	4	0
	8	0
	12	+6
	16	+12
	20	0
	24	+4
	28	+2
	32	+7
	36	+6

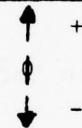
(b) Vertical Deviations 

Gantry Position		Deviation in
Distance in feet		.001" increments
X	0 Home Position	0
	4	0
	8	-1
	12	+2
	16	0
	20	-12
	24	+6
	28	-2
	32	-25
	36	-9

Table 5. X Axis Alignment

5-2.3 Horizontal Alignments of Y Axis - A target scale was positioned under the tape placement head in the placement roller location.

A transit was set up in line with the Y axis motor positioned at the Y direction end.

The Y carriage was programmed to move in 10" increments. The initial reading was taken at Y 0 or Home position. The results are shown in Table 6 (a).

5-2.4 Vertical Alignment of Y axis Motor - With a scale mounted on the Y carriage, a transit level, located at the head-stock end of the machine, was used to obtain changes in the height of the Y carriage, moved in 10" increments.

The gantry remained stationary at a position X-192.00.

The results are shown in Table 6 (b).

(a)

Horizontal Deviations

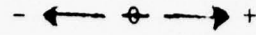

Gantry Position Distance in feet		Deviation in .001" increments
X	0 Home Position	0
	10	+1
	20	+5
	30	+7
	40	+2
	50	+5
	60	-1
	70	-1
	80	-1.5
	90	0

(b)

Vertical Deviations

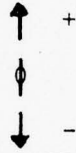

Y carriage position Distance in inches		Deviation in .001" increments
Y	0	0
	10	-4
	20	-9
	30	-12
	40	-12
	50	-12
	60	-12
	70	-8
	80	-2
	90	0

Table 6. Y Axis Alignment

5-2.5 Y Axis Squareness with X Axis - To check the squareness of the Y Axis motion with the X motion, two precision transits were used.

The first was aligned along the length of the machine parallel with the center line.

A tooling plate 48" square, with four round tooling pins accurately set to form a square pattern, was mounted on the table surface with two of the pins parallel to the first transit.

The second transit was then set-up to be in line with the other pair of pins.

The layout is shown in Figure 74. The target was mounted under the tape head, and the Y carriage moved in 10" increments.

Readings, taken with the transit along the Y axis, are shown in Table 7.

The results show the straightness of motion of the Y axis at the tape placement point, superimposed on the general squareness of the Y axis to the X axis direction.

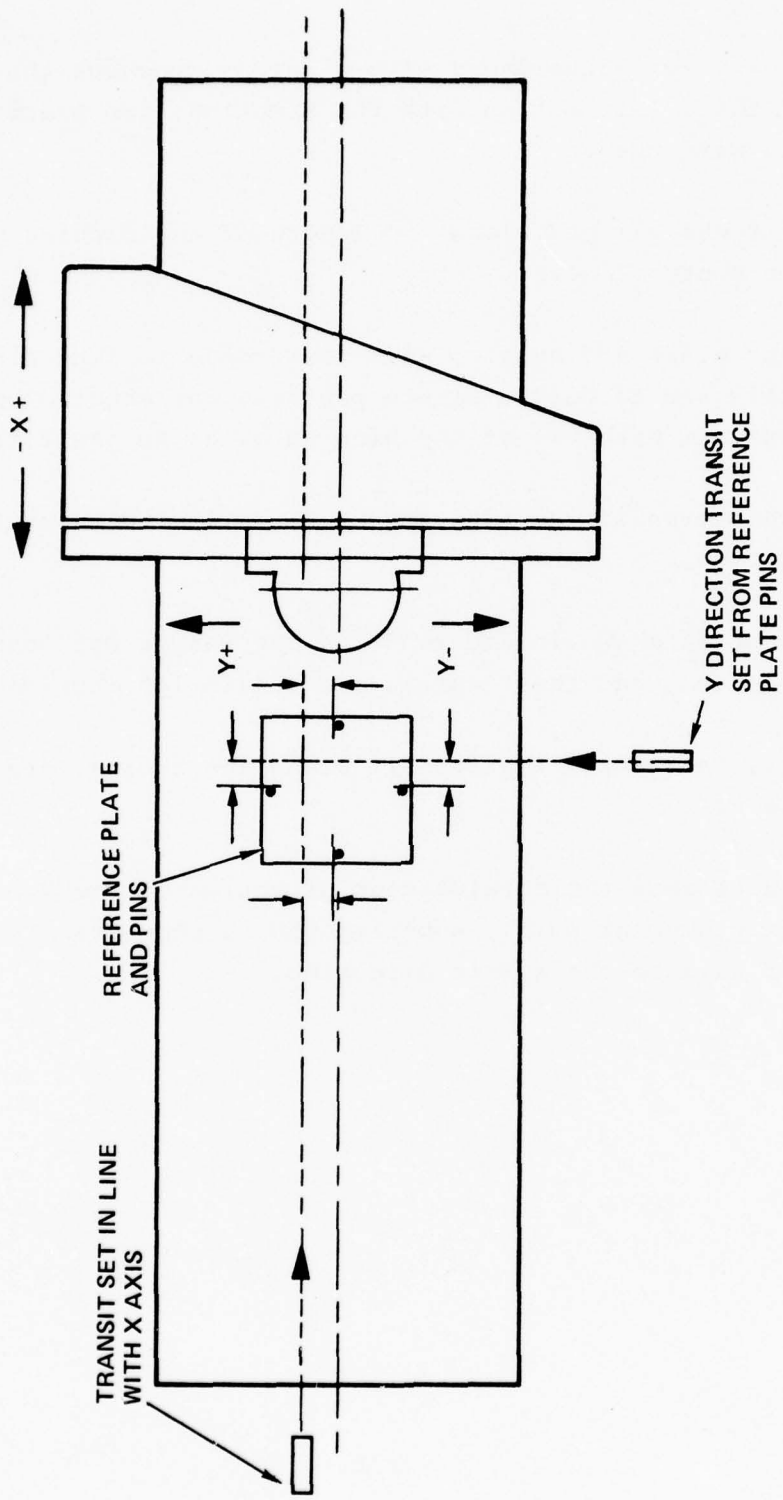

Figure 74. X & Y Axes Alignment

Y Axis Squareness to X Axis

Y Carriage Position		Deviation in
Distance in inches		.001" increments
Y	0 Home position	0
	10	0
	20	-6
	30	-11
	40	-16
	50	-16
	60	-16
	70	-17
	80	-18
	90	-20

Table 7. Y to X Axis Squareness

5-2.6 Z Axis Squareness to X Axis - The Z axis way tubular structures mounted on the two gantry carriages were checked for squareness to the "X" Axis. Since it is the motion of the placement point under the tape head which effects placement accuracy, most alignment checks were done by observing targets positioned there.

For the two Z way checks, the tape head was first positioned at full Y+ travel, on the main support side of the gantry. The second set of readings was taken with the Y carriage at home position.

A precision transit, set in a true level condition, was used to sight, in a vertical plane, a target positioned under the tape head.

The results of the two sets of readings are shown in Table 8 (a).

5-2.7 Z Axis Squareness to Y Axis - The transit was set up at the headstock end of the machine. The target mounted on the cross beam, was sighted at five vertical positions of the cross beam.

The readings are shown in Table 8 (b).

(a) Z Squareness to X Axis + 0 -

Z Position Distance in inches		Deviation in .001" increments	
		Gantry Drive Side	Support Side
Z	Top of Travel	0	0
	-5	-1	0
	-15	-3	+1
	-25	-5	-6
	-32	-6	-8

(b) Z Squareness to Y Axis

Z Position Distance in inches		Deviation in .001" increments
Z	Top of Travel	0
	-5	-1
	-15	+4
	-25	+6
	-32	+10

Table 8. Z Axis Squareness to "X" and "Y" Axes

5-2.7 Repeatability and Lost Motion of "X" Axis - Of particular interest were the repeatability and lost motion checks made in the X Axis direction.

Since the gantry is driven and guided from one side, any backlash in the drive and play in the guiding bearings would show up in these checks. Also the checks reflect the stiffness of the supporting gantry and its ability to maintain critical alignments.

5-2.7.1 A finger type of dial indicator, graduated in .0001" increments, was set up above the working surface of the machine, and positioned 12" in. from the edge of the base on the gantry supporting leg side.

A dowel pin was located under the tape placement head.

5-2.7.2 The X axis was moved to bring the dowel pin against the indicator and a zero established.

The X axis was then programmed to make ten excursions of 5" moves, going in a + direction at first then returning to contact the indicator.

5-2.7.3 The readings taken are shown in Table 9.

They show very good repeatability, well within the + or - .0025" of the specification.

5-2.7.4 Lost motion check - The next check was for repeatability of X axis from the other direction, as well as showing the lost motion. The dial indicator set up was unchanged from the repeatability checks preceding.

Readings taken with X axis approaching from the:

+ Direction	- Direction
0	
-.001"	+.002"
-.0012	+.0018
-.0013	+.002
-.0016	+.0019
-.0013	+.0019
-.0014	+.002
-.0013	+.0017
-.0012	+.0016
-.0013	+.0018

2nd set of readings from opposite direction showing lost motion

The (-) sign indicates the pin is short of the original 0 setting.

Table 9. X Axis Repeatability

5-2.7.5 A program was written which first moved the Y Axis to take the indicator away from the pin.

The X axis then made an excursion moving first in the -- direction followed by returning the Y axis to its original position.

5-2.7.6 The readings shown in Table 9 show a similar pattern to the repeatability readings shown from the other direction.

The results show a total spread of lost motion and repeatability of .0036" or \pm .0018".

5-2.8 Repeatability and Lost Motion of Y Axis - These checks were done in the same manner as the X Axis.

5-2.8.1 First the repeatability checks moving Y + then - in 5" excursions.

5-2.8.2 Then, repeatability and lost motion in the other direction was checked by first moving X axis to clear the pin from the indicator.

5-2.8.3 The results, shown in Table 10, show a high degree of repeatability and virtually no lost motion.

5-2.8.4 The design of the Y axis drive using an anti-backlash recirculating ball screw drive mounted under the cross beam close to the work surface resulted in the precision of this axis.

Readings taken with Y axis approaching from the :

+ Direction	- Direction
0	
-.0001"	+.0001
-.0001	+.00015
-.00015	+.00013
-.0001	+.00012
-.0001	+.00014
-.00015	+.00015
-.00013	+.0001
-.00014	+.0001
-.0001	+.00015

2nd set of readings showing lost motion from the original zero position.

(-) sign indicates the pin is short of the dial indicator original zero setting.

Table 10. Y Axis Repeatability

Development of a placement system to place and compact tapes on flat and compound curved surfaces became a significant part of the ATLAS Contract.

The inability of the first pneumatic placement roller to lay long straight pass with the required degree of control resulted in a number of different systems being tried. These ranged from rollers to a flexing pressure foot.

This section of the Report covers the development work done on placement systems as well as some observations on the glass epoxy tapes used.

5-3.1 The first pneumatic placement roller, as described in earlier sections of the Report and in Appendix II, had been designed to lay tapes on compound curved surfaces. The basic philosophy was to use the pneumatic feature to give a more uniform pressure distribution than a solid tire, and the ability to change the size of the foot-print, for a given down force, by varying the inflation pressure.

5-3.1.1 This placement roller was unable to lay long passes on a flat surface with sufficient accuracy due to the flexibility of the tread, with resulting lack of true running ability. To improve on this condition, another tire was made up with a flatter and stiffer tread.

5-3.2 The placement roller tire with the flatter and stiffer rim, or tread, was the one used in the initial tape placement trials at the Boeing-Vertol facility.

The basic construction of the tire was similar to the original softer one, except that it had a thicker and stiffer layer of glass fiber reinforcing.

After moulding, the tire had been mounted on a mandrel and the outside diameter ground.

Inspite of this, inspection of the outer surface after mounting to the hub and axle assembly showed a degree of run-out, which was to prove unsatisfactory for flat lay up work.

5-3.2.1 With the roller mounted in position under the tape head, a dial indicator was positioned against the rim and a series of readings taken to check the run-out. The indicator was positioned in three places; on the center line and 3/8" from each edge. The roller was rotated to take run out readings all around.

5-3.2.1.1 Readings were taken for two different inflation pressures, 15 psi and 25 psi. The results are shown in Table 11 and Table 12.

5-3.2.1.1.2 The change in inflation pressure did not make much difference to the run-out characteristics.

Indicator Position

Indicator Readings in Inches:

Rotation Position	Right	Center	Left
1.	-.003	.000	+.009
2.	-.002	+ .001	+.010
3.	-.000	+ .001	+.005
4.	-.003	- .002	+.005
5.	-.002	- .003	+.003
6.	-.002	- .001	+.003
7.	-.003	- .009	-.002
8.	-.003	- .015	-.010
9.	-.0075	- .015	-.010
10.	-.0185	- .016	-.009
11.	-.014	- .018	-.014
12.	-.010	- .017	-.016
13.	-.010	- .014	-.012
14.	-.007	- .008	-.002
15.	-.002	- .009	-.003
16.	-.000	- .000	+.002

Inflation pressure 15 psi.

Table 11. Placement Roller Run-out

Indicator Position

Rotation Position	Right	Center	Left
1.	-.0075	0	+.011
2.	-.005	+.003	+.014
3.	-.002	+.005	+.014
4.	-.006	. 0	+.010
5.	-.007	-.002	+.005
6.	-.008	-.002	+.005
7.	-.014	-.012	-.005
8.	-.015	-.015	-.010
9.	-.014	-.015	-.010
10.	-.019	-.013	-.005
11.	-.012	-.010	-.002
12.	-.007	-.007	-.002
13.	-.003	-.003	+.005
14.	-.004	0	+.008
15.	+.002	-.002	+.001
16.	0	0	+.004

Inflation Pressure 25 psi.

Table 12. Placement Roller Run-out

5-3.2.1.3 The most significant aspect of the run-out was the difference between the two outer edges. For example, at reading No. 4 on the 25 psi checks, Table 12, a variation from $-.006$ " on one side to $+.010$ " on the other side created a "wobble" action totalling $.016$ ", which was to show up during placement tests.

5-3.2.2 Placement Tests with Roller - A 12 x 4 ft. sheet of $1/4$ " thick aluminum was used as the working surface to lay up 3 inch wide glass epoxy tape during tests with the placement roller. Initial lay up was in short passes (24") in the Y axis direction. Placement accuracy on these short passes was within $\pm .025$ ". When longer passes (100") were made in the X direction, placement errors became more apparent.

By doing numerous lay up passes, consuming over 500 yd. of glass epoxy tape, the following factors were found to have effect on the lay down performance of the roller.

- a) Run out of the placement roller
- b) Tilt of the A axis
- c) Skewing of the C axis
- d) Condition, particularly temperature, of the tape.

5-3.2.2.1 The Run out of the Placement Roller Surface - The run out showed up during side by side lay ups in the X direction. The program was written to lay 110" long passes, side by side, starting always from one end and moving X axis in a + direction.

After the return of the gantry at the end of each pass, the Y axis was moved 3.050 ". This would give a theoretical gap between passes of $.050$ " for 3.000 " width tape. The width of the tape varied but was 3.020 " on average.

5-3.2.2.1.1 Eight passes were made. The gaps varied from .010" to .080". Also the gaps were not parallel along each pass showing a wandering type of path.

A repeating pattern in the gaps was observed. This pattern was thought to be caused by the run out of the roller surface.

5-3.2.2.1.1 The program was re-written so that the length of the passes were exactly four (4) revolutions of the placement roller (a length of 98.017").

5-3.2.2.1.3 Lay ups done with this program showed that the gaps were now uniform, so that each pass was behaving in the same way and following a similar path. This program was used in all the following investigations on the roller.

5-3.2.2.1.4 To check if the variation in placement load had any effect on the placement performance of the roller, a series of 8 pass side by side lay ups were done with varying placement force. The gaps were measured across the same points after each setting lay up. The results are shown in Table 13.

5-3.2.2.1.5 The results indicate that changes in load on the placement roller did not vary the lay up accuracy.

5-3.2.2.2 Effect of "A" axis Tilt - The effect of tilting the "A" axis on the accuracy of tape placement using the roller was briefly investigated.

5-3.2.2.2.1 Using the same programmed lay up length, passes were made with different positions of the "A" axis. The "A" axis rotates about the center point of the placement roller, and therefore, tilting will cause one side of the roller to compress more and the other less.

By making one pass then tilting the A axis 1/2 degree for the next pass, a run out of .100" was observed at the end of the second pass. Bringing the "A" axis back to its initial position brought the lay ups back in line after the third pass.

5-3.2.2.2.2 Angular settings as critical as this would make accurate digitizing and programming essential.

5-3.2.2.3 The Effect of C Axis Skewing - Some lay ups were done to see the magnitude of the placement errors caused when the "C" Axis was skewed from a true in-line position.

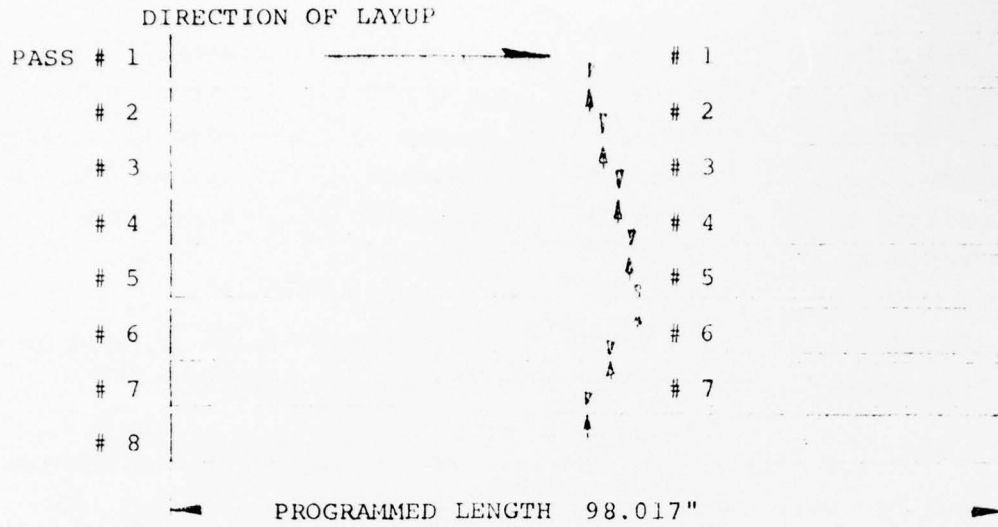

* Pressure setting on placement force

GAP NO	15 PSI	20 PSI	30 PSI	40 PSI	Gaps measured in .001"
1	45	30	45	30	
2	40	40	20	25	
3	45	35	45	20	
4	20	20	35	35	
5	45	45	45	45	
6	30	35	30	35	
7	50	35	45	45	

Note: Pressure setting of 32 PSI = 100 lbs. of placement force.

TABLE 13 - EFFECT OF COMPACTION LOAD ON ROLLER PLACEMENT ACCURACY.

AD-A037 447

GOLDSWORTHY ENGINEERING INC TORRANCE CALIF
U.S. ARMY AUTOMATED TAPE LAYUP SYSTEM 'ATLAS'.(U)
DEC 74 D S STEWART

F/G 13/8

UNCLASSIFIED

DRSAV-76-37

DAAJ01-72-C-0610

NL

3 OF 4
AD
A037447



The machine was programmed to lay some 30" passes with the Placement Roller moving in the Y direction.

Passes were made with "C" at 270.00°, then changed by 1/2 degree to 270.50°. With the 1/2 degree change, the tape ran out by .060" in the 30" pass length. Returning "C" to 270.00° brought successive passes back to a parallel condition.

5-3.2.2.4 The Effect of Tape Condition - Poor layup accuracy was observed when some layup passes were done with tape in a too cold condition. The tape, in a 500 yd. roll, had been in a cold storage room at 0°F and brought into the controlled 70°F ambient condition area and allowed to stabilize for 45 minutes.

5-3.2.2.4.1 The machine was programmed to lay successive 98.017" long strips on top of each other, and all laid in the same direction. The second pass was seen to be out of line compared to the first one beneath it. Successive passes showed a random pattern in terms of misplacement.

5-3.2.2.4.2 Six passes were made and measurements taken to evaluate the placement errors. At the worst position, the total band width was found to be 3.630 inches. The tape was 3.020 wide, thus giving a maximum placement error of .610 inches or $\pm .305$ inches.

5-3.2.2.4.3 The tape was allowed to stabilize for a further 60 minutes. The same layup was then repeated. This time the maximum laid width was 3.125, given a placement error of .105 inches.

5-3.2.2.4.4 Subsequent lay ups were always done with tape stabilized to room temperature for 24 hours before.

5-3.3 Solid Rubber Rim Roller - It was decided to fabricate a solid rubber rim placement roller to investigate its performance, particularly its ability to conform to a 2 inch radius surface.

5-3.3.1 The 1 1/2" thick x 4" wide rubber rim was molded on to an aluminum hub in an accurately machined concentric mold. The material used was RTV silicone rubber, white in color. The hardness was found to be 45 shore.

5-3.3.2 To test its ability to conform to a 2 inch radius, it was positioned over a 4 inch dia cylinder with its axis at right angles to the cylinder and loads with a force of 150 lbs. The width of the footprint was measured and found to be 1.75 inches.

5-3.3.3 A much softer rubber would be required to give a full 3 inch wide footprint.

5-3.3.4 One disadvantage with a solid tire is the uneven pressure distribution which would lead to uneven compaction of a composite layup.

5-3.3.5 While this roller was being fabricated, other placement systems were being evaluated which showed promise of being able to do the accurate tape placement. Consequently, the solid rim tire was not further developed.

5-3.4 Spatula Type Placement Unit - The first non-rotating placement device tried out was a form of spatula. Made of .030" thick stainless steel sheet, the spatula formed a curved guide to bring the tape from its vertical path round to the point of placement. A roll of rubber sheet, mounted under a rigid support in the axle location of the tape head, provided the compaction force to the spatula. Figure 75 (a) shows the principle of the system.

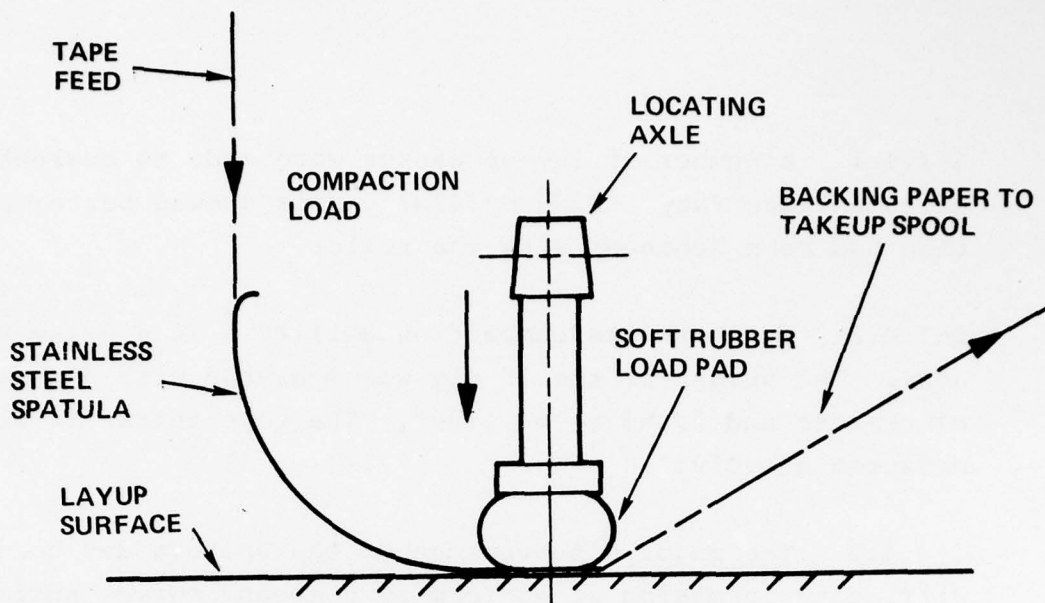

(a) SPATULA TYPE PLACEMENT UNIT

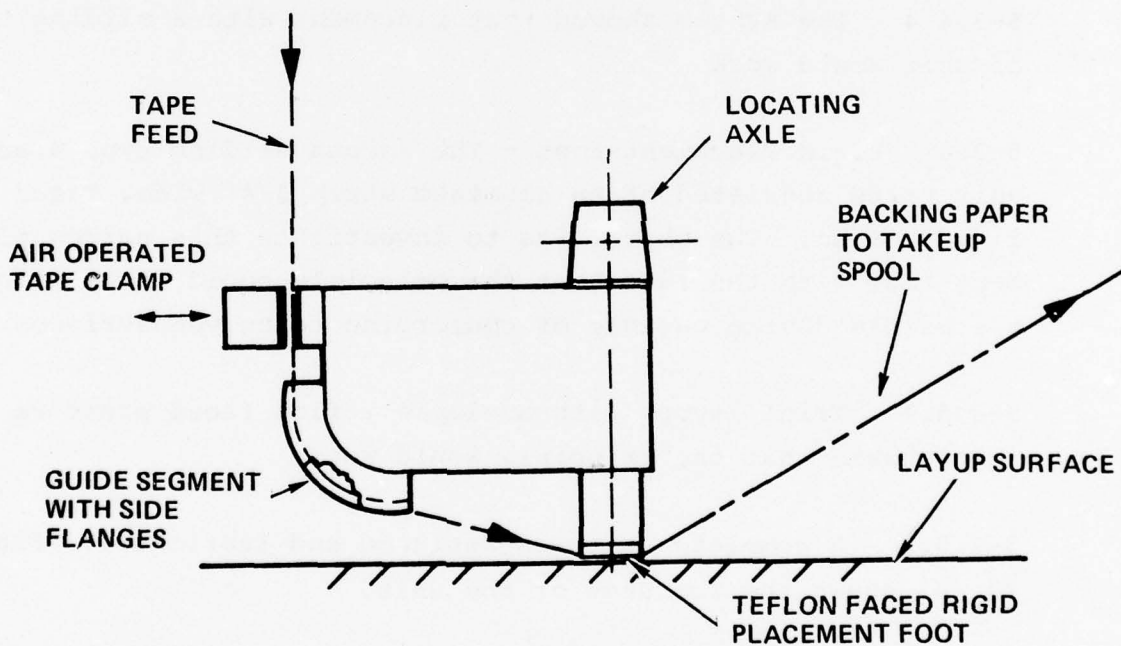

(b) RIGID TEFLON FOOT PLACEMENT UNIT

Figure 75. Non-Rotating Placement Units

5-3.4.1 A number of lay-up passes were made to evaluate the placement accuracy. Side by side passes showed better placement than had been achieved with the roller.

5-3.4.2 To check its compaction ability a 10 ply lay up was done. The height of the 10 ply was measured with a depth micrometer and found to be .106". The tape thickness was measured at .0105".

5-3.4.3 The major disadvantage of the spatula device is the difficulty in making it conform to compound curved surfaces since it already has curvature in the opposite plane.

5-3.4.4 The system showed that placement with a sliding type of unit would work.

5-3.5 Rigid Placement Foot - The second sliding type placement unit tried consisted of an aluminum strip 3/4" wide, faced with rigid teflon. The object was to investigate this narrow placement foot with the idea that the principle could develop into a flexible device capable of conforming to curved surfaces.

5-3.5.1 Trial layups with a simple teflon faced pressure foot showed that the principle would work.

5-3.5.2 A complete unit was designed and fabricated. Figure 75 (b) shows the features of the unit.

5-3.5.3 The tape feeds down past a clamp which is actuated by two air cylinders (previously used for the shoe on the Roller system). The air cylinders are actuated by "M" function commands from the numerical control. The purpose of the clamp is to hold the tape in position when lifting off at the end of a pass until the next lay down pass is started.

5-3.5.4 The tape is then guided round a curved guide which has side flanges on it. The flanges help to guide the tape providing accurate sideways location close to the placement point. The initial guide had a dimension of 3.025" between the flanges.

5-3.5.5 The placement foot, teflon faced with a chamfered leading edge, is rigidly mounted as part of the unit.

5-3.5.6 This placement unit was fabricated, assembled and lined up in true position in the axle location under the tape head. Adjustments were made to position the flanges on the tape guide equally about the centerline of rotation of the tape head.

5-3.5.7 The "cut-off" length from the tape shear to the center of the placement foot was established by measurement and by successive trial lay ups.

5-3.5.8 This placement unit was used for the ATLAS Demonstration, and for the Flat Pattern Acceptance Tests. Reports of its performance are covered in Sections 5-4.2 and 5-6.

5-3.6 Flexible Placement Foot - A flexible placement foot unit was designed and fabricated. Its design was based on the same configuration as the previous rigid foot unit and uses a number of the same components. The clamping system and flanged tape guidance segment are common to both.

5-3.6.1 The flexible foot consists of a piece of rigid teflon attached at its center and allowed to flex at its ends through a linkage system. The linkage system is connected to an air cylinder. When the air cylinder retracts, the ends of the flexible foot are forced downwards.

Figures 76 and 77 show the unit with foot flat and flexed.

5-3.6.2 The unit was mounted to the tape head and the tape guide flanges located accurately. A solenoid valve was connected to the numerical control system and set up to switch "on" and "off" by "M" function commands.

5-3.6.3 Tests showed that the flex foot would conform to a 3 inch radius.

5-3.6.4 A program was written to lay up a pass on the root end mock up mandrel along the centerline starting at the almost flat section and finishing on the 6.75 diameter section.

5-3.6.5 Successive lay up passes done with the program showed the flex foot unit to be able to lay tape with good repeatability on flat and curved surfaces. Observation of the laid tape showed that the pressure distribution on the foot had not been uniform.

5-3.6.6 This unit was used during lay up tests discussed later in the Report. In particular, it was used for the root end wrap Acceptance Test passes.

5-3.6.7 Experience gained in using this flexing foot placement unit showed that the basic principles are sound. A second generation unit will be designed and tested.

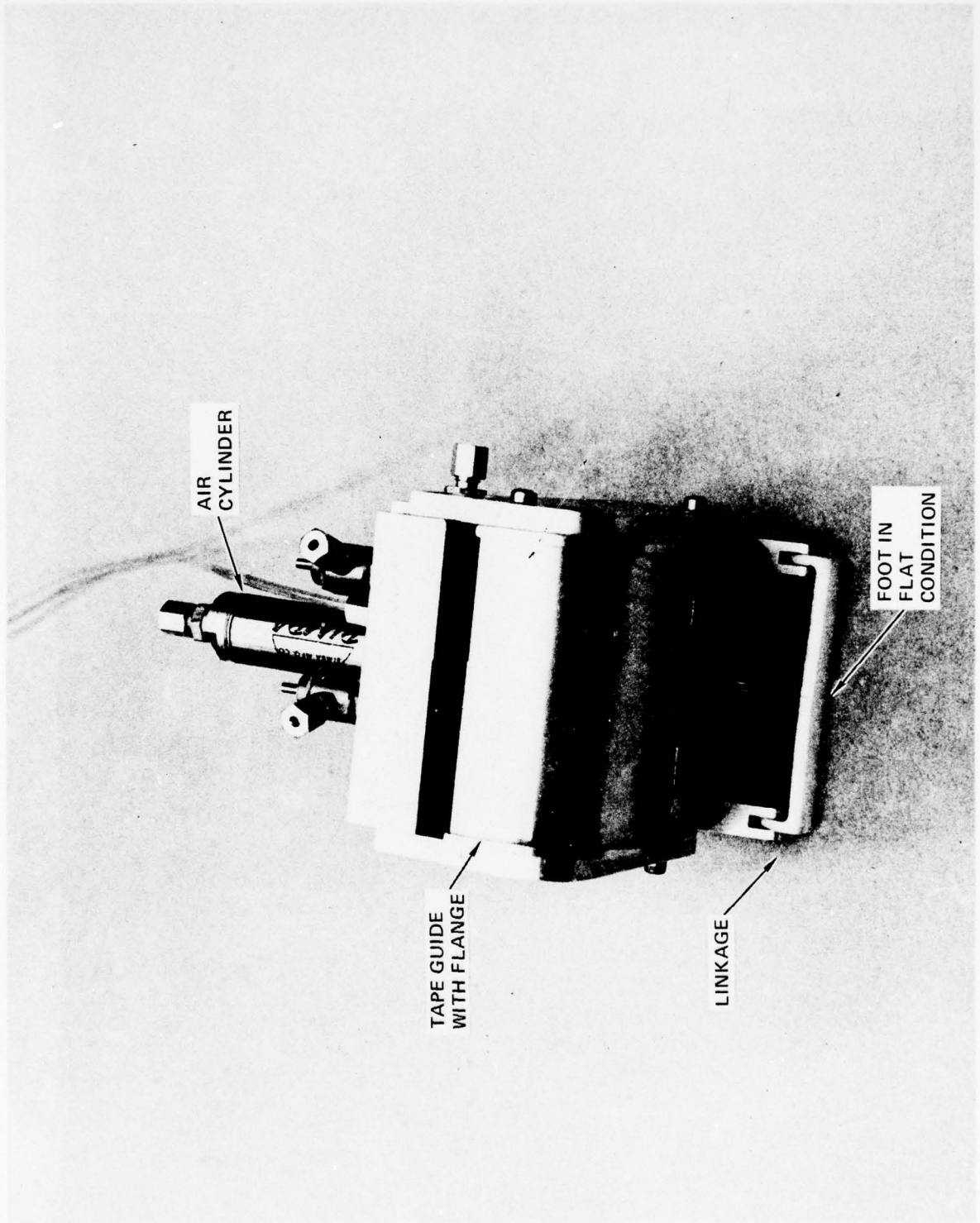

Figure 76. Flexible Foot Placement Unit

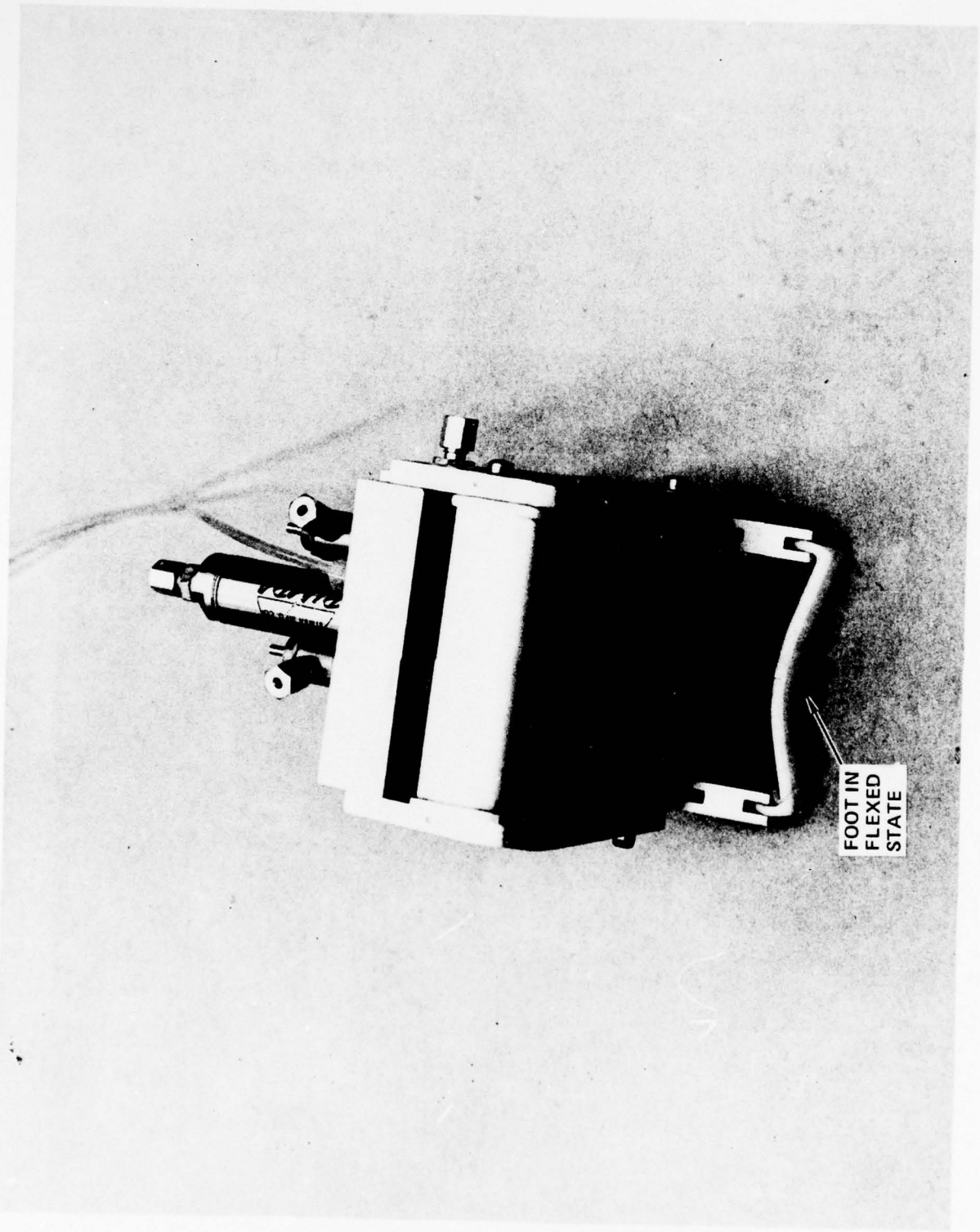

Figure 77. Flexible Foot Placement Unit

Part of this Phase of the ATLAS program was the demonstration of the machine to AVSCOM and other personnel. The demonstration was designed to show the machine's reliability, repeatability, and potential for lay up of composite structures.

This section covers the preparation work done, and the various aspects of the demonstration.

5-4.1 Six axes coordinated motions - This part of the demonstration was to show the six axes of the machine in motion, individually, and moving all together. A short program was written to do this and run through repeatedly before the demonstration to test the reliability of the machine being exercised at top speed.

5-4.2 Flat Pattern Lay up - The rigid teflon faced placement foot unit was the one used for lay up of a demonstration flat pattern. To demonstrate the flat pattern ability laying at different angles with different path lengths, a program was written to lay up the word ATLAS using 3 inch wide tape. The letters of the word ATLAS were programmed to be 31 inches high by 22 inches wide.

The program to lay up the letter "A" is shown in Table 14.

More information on programming the ATLAS machine is contained in Section 5-5.

Some points in the letter "A" program are worth noting at this stage.

BEST AVAILABLE COPY

G00000
N1X0Y0Z0A0C18000(ATLAS)
N2X29000Y17500C29000(LETTER A)
G91
X1092Y-3000
X-1092Y3000Z-2000
Z-500
S30
M62
M74
G04F100
Y-6443Y17703
M80
X-4840Y13297
M75
M63
Z500
X-1092Y3000Z2000
X-10088Y-23881C-11000
S70
X2000Z-2000
Z-500
S70
M62
M74
G04F100
Y4210
M80
X14150
M75
M63
Z500
X2000Z2000
X-10088Y23881C-11000
S50
X-1092Y-3000Z-2000
Z-500
S50
M62
M74
G04F100
Y-6443Y-17703
M80
X-4840Y-13297
M75
M63
Z500
X-1092Y-3000Z2000
G90
N3X30000Y40000C18000(LETTER T)
G91
X2000Z-2000
Z-500
M62

TABLE 14. - LETTER A PROGRAM PRINTOUT

5-4.2.1 The program was written in both absolute and incremental coordinate data. The code G90 sets it into absolute coordinates to establish the starting point in block N1 and N2; then switches into incremental mode (G91) for the lay up of the letter. By this means the position of the letter could be repositioned without changing the coordinate information in it.

5-4.2.2= The "S" words S 30 and S 70 are used to set the shear angle to -20° and $+20^{\circ}$ respectively.

5-4.2.3 The M62, M74, M75, M63, commands are used to turn the tape head automatic functions "on" and "off" and to "unclamp" and "clamp" the tape on the placement unit.

5-4.2.4 Demonstration of the ATLAS flat pattern was successfully accomplished. A second ply was laid up to demonstrate the high degree of repeatability.

5-4.3 Root End Wrap - A length of black line reference tape 1/2" wide was placed on the root end mock up in a path starting at the flat portion and spirally wrapping in towards the root end attach section.

This path was then digitized to develop the program for the machine motions.

Part of the program involved developing a path so that the tape head would leave the surface of the part and in a series of smoothed coordinated moves, wrap the tape over the edge sections, instead of contact placing. This type of combined placement and wrapping had not been done before. Development of this type of program is covered more fully in Section 5-5.3.

5-4.3.1 At the time of the demonstration only the rigid placement foot unit was available. As this was not suited to placement on the root-end spiral wrap, actual tape placement was not demonstrated. The machine was shown to make the six axis coordinated moves following the digitized reference path.

5-4.4 Torsional Ply Wrap - To demonstrate the combined placement and wrapping operation, on the root-end mock up, a program was developed to do a single 45° torsional ply wrap on the flatter portion.

By selecting almost flat surfaces for the start and end of the wrap, the rigid placement foot was able to place the tape satisfactorily.

The digitizing techniques used for this type of program are covered in Section 5-5.

5-4.4.1 Demonstration of this Torsion Wrap using 3" wide glass epoxy tape was satisfactorily achieved. A slow, 60 ipm feedrate was used so that the wrapping operation could be closely observed.

Development of programming techniques for the ATLAS machine presents a continuing effort.

Programming for this type of machine presents different approaches than those used for conventional machining operations. For instance, in the combined placement and wrapping operation, the placement unit leaves the surface. The path it must take in space must keep the tape following behind it on the right path as well as keeping the tape head rotation at right angles to that path. The programming for this is, therefore, similar to filament winding.

This section covers the Numerical Control programming format and covers the digitizing and programming techniques used during the final phase of the contract. A section on programming optimization looks at ways of simplifying the tasks involved in the programming of lay up on spar sections.

5-5.1 Following is a description of the coding used for the ATLAS. These codes will be used for all data inputted to this system.

5-5.1.1 Word Format - All inputted data will be formatted as follows: N4.G2.X+43.Y+43.Z+43.A+43.C+52.D+43.I43.J43.F43.S2.M2 (A); where the alpha character denotes the type of instruction and the numeric indicates the magnitude of the quantity and the number of significant figures required (i.e. N4 is a 4 digit sequence or block number and I43 is an arc center offset xxxx.xxx).

5-5.1.2 Word Descriptions - Following are descriptions of the types of instructions to be inputted to accomplish specific tasks.

5-5.1.2.1 Sequence/Block Number (N4) - A four digit whole number used to designate a portion of a program as a specific sequence as defined by the programmed sequence number. This code is used for program statement definition only and does not affect machine motions or operations.

5-5.1.2.2 Preparatory Functions (G2) - A two digit whole number used to establish a mode of operation, as follows:

G00 - (modal) Positioning Mode

Multi-Axis moves will be made vectorially at the programmed feedrate. When operating in this mode, the active block will close out following error to the in position band before the next block is transferred to active. This mode of operation is not recommended for contouring. Cancels G01, G02, or G03.

G01 - (modal) Linear Interpolation Mode

This mode is the turn-on or reset mode and is the recommended mode for slope contouring. Cancels G00, G02, or G03.

G02 - (modal) Circular Interpolation Clockwise

An arc generated by the coordinated motion of 2 axes in which the curvature of the path with respect to the workpiece is clockwise when viewing the plane of motion in the negative direction of the perpendicular axis. Cancels G00, G01, or G03.

5-5.1.2.2 (cont)

- G03 - (modal) Circular Interpolation Counterclockwise
An arc generated by the coordinated motion of 2 axis in which the curvature of the path of the tool with respect to the workpiece is counterclockwise when viewing the plane of motion in the negative direction of the perpendicular axis. Cancels G00, G01, or G02.
- G04 - (non-modal) Dwell
This code establishes a dwell in conjunction with a programmed F-word. The F-word is programmed in seconds (F32 format) allowing dwell up to 327.67 seconds. At completion of the dwell, the program resumes automatically. A previously programmed F-word will be reinstated and no other G-codes are cancelled.
- G17 - (modal) XY Plane Selection for circular interpolation. This mode is the turn-on reset mode. Cancels G18 or G19.
- G18 - (modal) ZX Plane Selection for circular interpolation. Cancels G17 or G19
- G19 - (modal) YZ Plane Selection for circular interpolation. Cancels G17 or G18.
- G90 - (modal) Absolute Programming Mode. This mode is turn-on or reset mode. This code cancels G91.

5-5.1.2.2 (cont)

- G91 - (modal) Incremental Programming Mode. This cancels G90.
- G93 - (modal) V/D Feedrate Coding. Allows feedrate coding by programming an F-word designating V/D (inverse time).
- G94 - (modal) IPM Feedrate Coding. This mode is the turn-on or reset mode. Allows feedrate coding in IPM for any combination of the X-Y-Z axis or degrees per minute for any combination of the A-C-D axis.
- G98 - (non-modal) Insert Absolute Offset. This code shall be used to preset any axis position to any desired absolute dimension. The machine slide will not move and absolute offsets may be entered on tape or thru MDI. The absolute position of the slide relative to machine zero at the time a G98 offset is inserted and stored. (NOTE: It is assumed that after power turn-on, a machine zero synchronization procedure had been performed.) The G98 block then establishes a new absolute position for the same slide physical position. G98 does not cancel any other G codes and the inserted offsets are cleared by programming the actual slide physical locations relative to machine zero along with another G98, by resynchronizing the axis with a Machine Zero operation, by programming a G99 cancelling code, and by MCU RESET. It should be noted that the G98/set zero offsets are accumulative and mutually inclusive.
- G99 - (non-modal) Cancels Absolute Offset. G99 will cancel the accumulation of G98 presets and set zero offsets.

5-5.1.2.3 Miscellaneous Functions (M2) - A two digit whole number.

Key: A - Activated (After) interpolation of the block in which stored.

I - Activated (Immediately) upon transfer into active storage.

M00 - (A) Program Stop

This code initiates a program stop.

M01 - (A) Optional Program Stop.

This code has the same function as M00 except that it is ignored if not enabled by a manual switch on the Main Control Panel. (Switch must be returned to the ON position.)

M02 - (A) End of Program.

This code has the same effects as M00 except that it indicates an End of Program condition. Additionally, this code insures that all the active storage registers are cleared, cancels parity check until the first EOB is read in the forward direction, and sets up the control logic to begin a new program when the Cycle Start button is depressed. All M codes and S codes are cancelled by M02.

M25 - (I) Z Retract.

This code causes the Z axis to move to home position. Axis data programmed in a M25 block will be ignored.

M30 - (A) End of Program - Rewind.

This code has the same function as M02 except that it also commands a tape rewind to the End of Record (EOR) code.

5-5.1.2.3 (cont.)

- M62 - (I) Auto Head Control ON. This code is reset by M02, M30, M63, M79 and M89.
- M63 - (A) Auto Head Control OFF.
This code is reset by M62.
- M64 - (A) This code turns ON the Slitting Rolls. This code is reset by M02, M30, M65, M79 and M89.
- M65 - (A) This code turns OFF the Slitting Rolls.
This code is reset by M64.
- M66 - (A) Pay-off Reel, Full Torque ON.
This code is reset by M02, M30, M67, M79 and M89.
- M67 - (A) Pay-off Reel, Full Torque OFF.
This code is reset by M66.
- M68 - (A) Take-Up Reel Low Torque ON.
This code is reset by M02, M30, M69, M79 and M89.
- M69 - (A) Take-Up Reel Low Torque OFF.
This code is reset by M68.
- M70 - (A) Unassigned
- M71 - (A) Unassigned
- M72 - (I) Flexing Compactor ON.
- M73 - (I) Flexing Compactor OFF.
- M74 - (I) Tape Clamp OFF.
This code is reset by M02 M30, M75, M79 and M89.

5-5.1.2.3 (cont.)

M75 - (A) Tape Clamp ON.

This code is reset by M74.

M76 - (A) Unassigned.

This code is active only while the block of information in which it is programmed is in active storage.

M77 - (A) Unassigned.

This code is active only while the block of information in which it is programmed is in active storage.

M78 - (I) Unassigned.

This code is active only while the block of information in which it is programmed is in active storage.

M79 - (A) Reset all MDI M Codes.

This code is active only while the block of information in which it is programmed is in active storage.

M80 - (A) SHEAR ON.

This code is active only while the block of information in which it is programmed is in active storage. This code inhibits transfer of the next block of information to active until the machine signals the shear operation is complete.

M81 - (A) COMB OUT START.

This code is reset by M02, M30, M82 (and inhibit removed), M79 and M89.

5-5.1.2.3 (cont.)

M82 - (A) COMB OUT STOP.

This code will cause a COMB OUT STOP if the COMB OUT STOP inhibit is removed by the machine. When a M82 code is active and the inhibit is present the next block of information is inhibited to active until the COMB OUT inhibit is removed.

M83 - (A) Unassigned

M84 - (A) Unassigned

M89 - (A) This code cancels all MDS M Codes. Upon output of M89 all MDS M codes will be cancelled and transfer will be inhibited until the inhibit is removed by a signal from the machine.

5-5.1.2.4 Linear Motion Dimension Words (X±43, Y±43 & Z±43 format) -

All dimension words consist of a letter address (X, Y or Z axis), a direction sign (minus is programmed, plus is assumed), and a command dimension in inches. All linear motion dimension words have leading zero suppression. A linear axis is programmable to .001 inch resolution and will have a maximum programmable departure per block of 9999.999 inches even if this is beyond the machine capability. Any linear command which exceeds the physical capability of a particular axis will actuate an Overtravel limit switch and cause the system to shutdown.

5-5.1.2.5 Rotary Motion Dimension Words (A±43, C±52 & D±43 format) -

All rotary axis dimension words consist of a letter address (A, C or D axis), a direction sign, and a command dimension in inches. All rotary dimension words have leading zero suppression. A rotary axis is programmable to 0.01° resolution. The maximum programmable departure in one block could be 99999.99° in the G91 (incremental) input mode. In the G91 mode, the position counter and display will essentially roll

5-5.1.2.5 (cont.)

over at 359.99° such that incremental moves are really converted absolute positions. If G90 is in effect and the program move is greater than 359.99°, a Cycle Stop will occur and an ILLEGAL TAPE FORMAT message will appear on the CRT. If in Keyboard mode, the error will be denoted by an asterisk (*) in column one, line one of the CRT. This condition can be removed by depressing Active Reset.

5-5.1.2.6 Feedrate (F-word) Coding -

Feedrate characteristics vary with the function code it is associated with.

5-5.1.2.6.1 F-word coding (F43) in G94 (IPM) Mode -

In the G94 Mode, the F-word designates inches per minute for the linear axis from .001 IPM to 720.0 IPM. Feedrate can be programmed directly in IPM in the G00 (positioning) mode and also when contouring (G01, G02, G03) with any combination of the three linear axes. The rotary axes should not be programmed in combination with the linear axis while contouring in the G94 mode. If programmed this way, linear and rotary motion will complete their move at the same time as the linear axis. However, the feedrate along the contoured path is not equal to the programmed IPM value. Large rotary departures combined with small linear departures will cause large feedrates. If these departures cause the rotary feedrates to exceed the value at the gain break point, the correct contour will not be generated. The F-word in conjunction with a G94 designates degrees per minute (DPM) when the rotary axis are programmed without linear axis movement while in the G00 or the G91 mode. The F-word is modal for the G94 mode.

5-5.1.2.6.2 F-word Coding (F43) in G93 (V/D) Mode -

In the G93 (V/D) mode, the F-word is equal to the velocity in IPM divided by the distance in inches.

$$F = \frac{V}{D} = \frac{\text{Inches/Min.}}{\text{Inches}} = 1/\text{Min.} = 1/t \text{ (Min.)}$$

5-5.1.2.6.2 (cont.)

The range of the F-word in inverse time mode is .001 to 9999.999. The F-Word is non-modal for the G93 state and must be programmed in every block; otherwise, an illegal tape format will result.

5-5.1.2.6.3 F-word Coding (F32) in G04 (Dwell) Mode. - The F-word, when programmed in the same block with a G04, will cause a programmed dwell from 00.01 to 327.67 seconds. The G04 dwell is programmable with a G93 or G94 in effect in either positioning or contouring mode. The program resumes automatically upon completion of the dwell and a previously programmed F-word is reinstated. The F-word is non-modal when used with a G04 dwell. The dwell must be programmed in a separate block.

5-5.1.2.6.4 F0 Rapid Traverse Code - An F0 programmed in either positioning or contouring mode with either a G93 or a G94 in effect will cause rapid traverse. At least one zero must be programmed. In either the G00 or the G01 mode, a programmed F0 will cause all linear slides to move at a rate necessary to give a vector velocity equal to the rapid traverse rate. If an F0 is programmed with both linear and rotary axis in the block in either the G93 or G94 modes, the feedrate of the programmed axis with the slowest feedrate will be used. The rotary axis will be followers if programmed with linear axis. An F0 programmed for a combination of two rotary axes will give a vector velocity equal to the maximum velocity of the slowest axis. An F0 programmed in the G02 or G03 modes will cause the respective slides to move at a rate necessary to give a vector velocity equal to the rapid traverse rate. The F0 code is modal in either the G93 or G94 modes respectively. F0 replaces a previously programmed F-word.

5-5.1.2.6.5 Feedrate Coding General Characteristics

a. Feedrate Suppression. Each servo controlled axis will lag the command by an amount proportional to velocity. This position lag is called following error (FE). The System 7300 control continuously monitors following error. If FE increases above a set limit, the control automatically reduces by half the command. This allows FE to diminish. This feature is known as Feedrate Suppression.

b. Four, Five, or Six Axes FRN* Calculation. Calculating the FRN for programs involving four, five or six axes involves special consideration of the orientation of the rotary axis with respect to the conventional axis. During a movement, a FRN should be representative to the actual length of the maximum lateral path of any point on the O.D. of the tape head roller. The necessity of simultaneous rotary motion with conventional linear motions may result in a swept out path which is either considerably longer or shorter than the vector described by X, Y, and Z.

5-5.1.2.7 Shear Spindle Angle (S2)- This code provides 2 digits for shear spindle angle coding.

5-5.1.2.8 Arc Center Offsets (I43, J43, K43) - The arc center offsets entries, I, J and K define the distance between the center of the arc and the starting position of the arc. The I entry is the distance parallel to the X-axis from the starting position of the arc to the arc center. The J entry is the distance parallel to the Y-axis from the starting position of the arc to the arc center. The K entry is the distance parallel to the Z-axis from the starting position of the arc to the arc center. Signs (+ or -) must not be entered with arc center offset entries. IØ, JØ or KØ values need not be programmed when they occur.

* FRN = Feed Rate Number

5-5.1.3 OPERATIONAL FEATURES

5-5.1.3.1 Circular Interpolation - Single Plane. This feature allows the generation of up to a full quadrant of a circular arc in one block of tape. Circular is possible in any of the three planes defined in the X-Y-Z coordinate system. Because of plane selection, two blocks of tape may be necessary to generate the first quadrant. The block sequence and required content are as follows:

1st Block - G17, (G18 or G19). This entry defines the plane of operation. G17 defines the XY plane, G18 defines the ZX plane, and G19 defines the YZ plane. A plane once selected is modal and remains in effect until a complementary cancelling plane is selected or an MCU RESET manual pushbutton function is performed. The G17 plane is the turn-on or reset plane and is the plane in effect when control power is turned on.

2nd Block - G02 (G03). Defines whether the arc is to be generated in the clockwise or counterclockwise direction respectively. Direction conventions are as defined in Paragraph 5-5.1.2.2.

Note: At the discretion of the programmer, multiple G codes may be programmed in one block (i.e. G17, G02).

X Dimension -

Defines the X-axis distance from the beginning of the arc to the end of the arc. Minus (-) sign must only be entered; plus (+) sign is understood: (NOTE: Sign entry requirement applies also to Y and Z dimensions.)

I Dimension -

Defines the incremental distance parallel to the x-axis from the center of the arc to the beginning of the arc.

5-5 .1.3.1 (cont.)

Y Dimension -

Defines the Y-axis distance from the beginning of the arc to the end of the arc.

J Dimension -

Defines the incremental distance parallel to the Y-axis from the center of the arc to the beginning of the arc.

Z Dimension -

Defines the Z-axis distance from the beginning of the arc to the end of the arc.

K Dimension -

Defines the incremental distance parallel to the Z-axis from the center of the arc to the beginning of the arc.

F Feedrate Value -

The feed function in circular interpolation mode can be programmed in either direct IPM or Inverse Time Feedrate Number. In the G94 (IPM) mode of operation, feed can be programmed as described under Paragraph 5-5.1.2.6.1 and will be tangential feedrate. In the G93 1/t mode of operation, feedrate as an inverse time number is expressed as:

$$F = \frac{V}{R} \text{ where } F = \text{Feedrate number ranging from } .001 \text{ to } 9999.999$$

V = desired tangential feedrate in IPM

R = radius in inches 9999.999"

$$\text{thus } F = 1/T \text{ (minutes)}$$

The maximum tangential feedrate permitted is 720 IPM although in some applications of this control, this capability will be limited to some lower value.

5-5.1.3.2 Circular Interpolation combined with 3rd Axis Linear Movement. It is possible to program a third linear axis movement to occur while the other two linear axis are performing circular interpolation. This operation permits the generation of helix-type contours. The third axis movement can not be rotary. Programming this feature is similar to the method used for circular interpolation alone with two exceptions:

- a. The departure command for the third linear axis movement must be programmed. This command is signed.
- b. The rate of movement for the third linear axis is a function of a rise per radian command which is programmed with the appropriate letter address (I, J or K) corresponding to the third axis departure. The I, J and K words in this application are defined as follows:

I	- $\frac{x \text{ departure}}{YZ \text{ arc in radians}}$	G19
J	- $\frac{y \text{ departure}}{ZX \text{ arc in radians}}$	G18
K	- $\frac{z \text{ departure}}{XY \text{ arc in radians}}$	G17

The I-J-K values are unsigned and are formatted as described in paragraph 5-5.1.2.8.

5-5.1.3.3 Block Delete - A block of data programmed on tape and preceded by a slash code(/) will be ignored by the system if the "block delete" function has been enabled by a switch on the Main Control Panel. Turning the "block delete" two-position selector to the ON position enables the function.

5-5.1.3.4 Optional Stop - An MØ1 programmed on tape will cause a "program stop" condition if the "optional stop" function has been enabled by a switch on the Main Control Panel. Turning the "optional stop" two position selector to the ON position enables the function.

5-5.1.3.5 Mirror Image - Sign Reversal Switches - Each servo controlled axis has associated with it a sign reversal switch. When in the NORMAL position, this switch will allow axis movement in the directions as programmed. When in the REVERSE direction, axis movement will be in the directions opposite to that programmed.

5-5.1.3.6 Programmed Dwell - Dwells up to 327.67 seconds can be programmed with a GØ4 code and appropriate F number. Dwell should be programmed as a separate block without axis dimension commands. Refer to Para. 5-5.1.2.2 for additional information.

5-5.1.3.7 Block Format and Tape Format Considerations -

5-5.1.3.7.1 Initial Tape Code Assignments - Every tape shall begin in the following sequence: EOR-EOB-FIRST BLOCK. Each additional part program should commence with EOB - FIRST BLOCK.

5-5.1.3.7.2 End of Record - The "end of record" (EOR) character serves as a tape rewind stop and must appear at the beginning of a tape.

5-5.1.3.7.3 End of Block - The "end of block" (EOB) character must be used after the last character in each block of information.

5-5.1.3.7.4 RS-244 (EIA) and RS-358 (ASCII) Coding - The particular type of tape coding is determined automatically by the control. It does this by decoding the first EOB on tape to determine its coding. Once determined, the coding remains in effect until an End of Program condition exists. (An End of Program condition exists after power turn-on, after a MØ2 or M3Ø.) The decoding and code setup procedure will again occur at the beginning of the next program when the first intended EOB is read. The tape leader must not contain an EOB of the EIA or ASCII set.

5-5.1.3.7.5 Address Sequence and Block Content - Words within a block may follow any convenient sequence. Redundant letter addresses are not allowed in a block. The only exception to this constraint are G codes which can be multiple per block. Should redundant letter addresses appear in one block, the one nearest the EL* and its associative numerics will be recognized by the System 7300. Decimal point, tab characters and other non-functional characters programmed will cause a decode error (displayed on the CRT). All words have leading zero suppression.

5-5.1.3.7.6 Man-Readable Information - Man-Readable descriptive information may be included at the beginning of a tape prior to the first intended EOB. This information must not contain a character with the same hole configuration as the RS-244 or RS-358 defined EOB.

5-5.1.3.7.7 MØ2 - MØ3 Code Reset Effects - These codes have the following reset effects:

- a. Cancels parity check.
- b. Cancels all active and temporary storage registers.
- c. Sets up the control to read and decode the first intended EOB.

Note: These reset effects allow the insertion of Man-Readable information between tapes which are spliced together.

* EL = End of Line

5-5.1.3.7.8 CRT Display Messages Using Control In/Control Out - A message on tape bracketed by control in ("and control out") characters as defined by RS-348 will be displayed on the CRT along with the normal data in the block in which it occurs. This feature can be used for operator instruction in conjunction with a PROGRAM STOP. It is recommended that the total number of characters in a block using this feature be limited to 84 as this is the maximum number allotted per block for CRT display. If more than 84 characters are programmed, the remainder will not be looked at or acted upon.

5-5.1.3.7.9 Block Times of Tape Reader - Since the System 7300 control has an eight block buffer which is replenished four blocks at a time, block read time is not normally a problem with this system.

5-5.1.3.7.10 Minimum Interpolation Time - The minimum interpolation time for a block of data in active storage is 60 milliseconds.

5-5.1.3.7.11 Delete Codes - The System 7300 will recognize punches in tracks 1-7 or 1-8 as being delete codes regardless of the coding being used. Thus, an 8 hole delete code in RS-244 can be used to delete EOB character without giving a parity error. With RS-358, the 8 hole delete code is the normal delete.

5-5.1.3.7.12 Block Length - Block length is 84 character maximum.

.1.3.8 Directions of Travel - The directions of travel are in accordance with EIA standard RS-267A.

5-5.1.3.9 Acceleration and Deceleration Timing - There are no limitations in regard to the minimum block length for a given step input. The minimum block length may be programmed at the maximum velocity step.

5-5.1.3.10 Set Zero Manual Operation- An operator pushbutton, located on the Secondary Control Panel, when depressed will cause on a per axis basis, the present axis position to be defined as the AXIS ZERO position. No slide movement will occur.

5-5.1.3.11 Machine Zero Manual Operation - This operator initiated function is the synchronization procedure performed at power Turn-On to establish the normal MACHINE ZERO or GRID positions.

5-5.1.3.12 Feedrate Override - This control is equipped with an axis feedrate override switch. The feedrate override ranges from 0-120% in 10% steps. System software interlocking insures that no feed above the recommended maximums can occur because of these switch settings.

5-5.1.3.13 Active Storage Reset Capability - An operator pushbutton on the MCU front panel provides an active storage reset feature. This button, when depressed, clears the axis active storage registers and aborts any machine dependent function in the process of execution. This function is only possible in a Cycle Stop condition.

5-5.2 Flat Layup Program - The program used to layup the letter L, taken from the ATLAS demonstration, is an example of a flat layup program.

5-5.2.1 The letter L program is as follows:

G90
N4X60500Y43500C9000 (Letter L)
G91
Y-2000Z-2000
Z-500
M62
M74
G04F100
Y-16850
M80'
Y-14150
M75
M63
Z500
Y-2000Z2000
X-500Y3500C9000
X2000Z-2000
Z-500
M62
M74
G04F100
X4850
M80
X14150
M75
M63
Z500
X2000Z2000
G90

5-5.2.2 Analyzing this program shows the movements of the X,Y,Z and C axis, as well as the operation of the required M functions. Taking it block by block, as follows:

5-5.2.3

G90 puts the control into absolute mode prior to the next block.

N4X60500 - contains the absolute coordinates of the X Y axis and the tape head direction, C, for the first pass.

G91 puts the control back into incremental departures.

Y-2000Z-2000 - is a combined Y and Z move which brings the placement unit in a 45° "glide path" to the position of the start of the pass. This "glide path" is used to prevent wrinkling of any tape that might have separated from the backing paper.

Z-500 brings the placement foot down to the surface.

M62 is Auto head ON. This turns on the head functions and in particular pressurises the placement load cylinder.

M74 releases the tape clamp.

G04F100 gives a one second time delay to ensure good adhesion of the tape to the work surface.

Y-16850 is the first part of the pass. The machine then stops to do the tape shear operation.

M80 the tape shear is actuated for a given time set by the timing control on the tape head. Any movement of the machine is inhibited during this time.

Y-14150 the pass is completed by a Y axis move which is the "cut-off" length 14.150".

M75 Puts the tape clamp ON.

M63 turns the Auto Head OFF.

Z500 gives a short lift off.

Y-2000Z2000 is a pull away move.

X-500 moves the head to start the next pass, rotating the head "C" to bring it in line.

X2000Z-2000 the lift off and away at the end of the pass.

G90 puts the control back into absolute departure mode ready to move to the next letter of the layup program.

5-5.3 Multi-axis Programming Using Digitizing Techniques -
Two basic digitizing techniques were developed to produce programs for multi-axis layup work.

5-5.3.1 The line follower device, with the hand held control box (described in Section 4-5) was developed for use when the unit is in contact with the surface of the part being digitized. It has a self seeking Z axis motion that brings the unit down until it stabilizes on contact with the surface.

On a helicopter blade layup, this line follower will be used to digitize the long tape paths going from the tip down to the root-end attach point.

To digitize a typical path using the line follower, the procedure would be as follows.

5-5.3.1.1 The black line reference tape would be positioned along the desired path. Marks put on it would indicate the points at which other information, such as tape shear (M80) would be put.

5-5.3.1.2 With the line follower positioned at the start of the pass, the M functions to operate the tape head would be entered by the MDI keyboard and the Manual Execute button. (The slope deviation number would have been entered at turn-on of the control.)

5-5.3.1.3 The line follower would be initiated by pushing the Cycle Start button on the hand held control box. The gantry would then start moving in the X direction, under speed control from the control box, and the line follower keep tracking the line in Y axis and C axis, with "A" and "Z" following the surface. The tape punch would be producing digitized punched tape as the follower moves along the line.

5-5.3.1.4 At a point requiring extra input information, the follower is stopped by pushing the Cycle stop and Axis Lock buttons. This holds all axes under servo position by the numerical control while information is entered by the MDI keyboard and transferred to punched tape by the Manual Execute button, while in Manual control mode.

5-5.3.1.5 The line would be traced to the end of the pass, then position locked again for entry of the extra control information.

5-5.3.2 The development of techniques to do both tape placement and tape wrapping, particularly on torsion ply wraps, required some different digitizing hardware other than the line follower unit.

On a typical torsion wrap pass developed, a total of 16 digitized positions was required. Seven of these positions occurred with the placement foot not in contact with the surface of the part.

5-5.3.2.1 The digitizing aid developed to do this task (shown in Figure 58) consists of a holder which is located in place of the placement unit. A strip of mylar 1" wide with a black line down its center is located centrally, with the line oriented to be in the direction of laydown of the tape head. A short piece of mylar leads the unit and a longer tail trails it.

At the center of the holder is located the "bow tie" fiber optic device (described in Section 4-5.2.2). Outputs from this device are displayed on the hand held jog box meter.

5-5.3.2.2 The "bow tie" unit is used to aid positioning on the black reference line tape when digitizing with the unit in contact with the surface. X and Y axis can be jogged to null the meter with a repeatability of $\pm .001$ ".

5-5.3.2.3 To obtain the rotary position of the head, the black line on the mylar tape is usually lined up with the black reference line on the part surface, by jogging the "C" axis. Positional accuracy of .1 degree is easily detectable, since it represents a movement of .014" at the end of the 8 inch long mylar tail.

5-5.3.2.4 Digitizing a Torsional Wrap - Figure 78 shows the sequence of digitized points required to do one torsional wrap on the spar tooling.

- Point 1 Start of the pass. Bow-tie in contact with surface. Leading mylar strip gives "C" angle.
- Point 2 Intermediate point on surface.
- Point 3 Final point on surface before wrap.
- Point 4 Head lifted to release pressure on placement foot.
- Point 5 Placement foot moves out: No rotation of D at this point.
- Point 6 Wrapping operation. Mylar tail used to line up X, Y and C. D is moved in 30° increments between points.
- 10
- Point 11 Contact with surface.
- Point 12 Placement foot brought down 1/2" to provide pressure on surface.
- Point 13 End of pass.

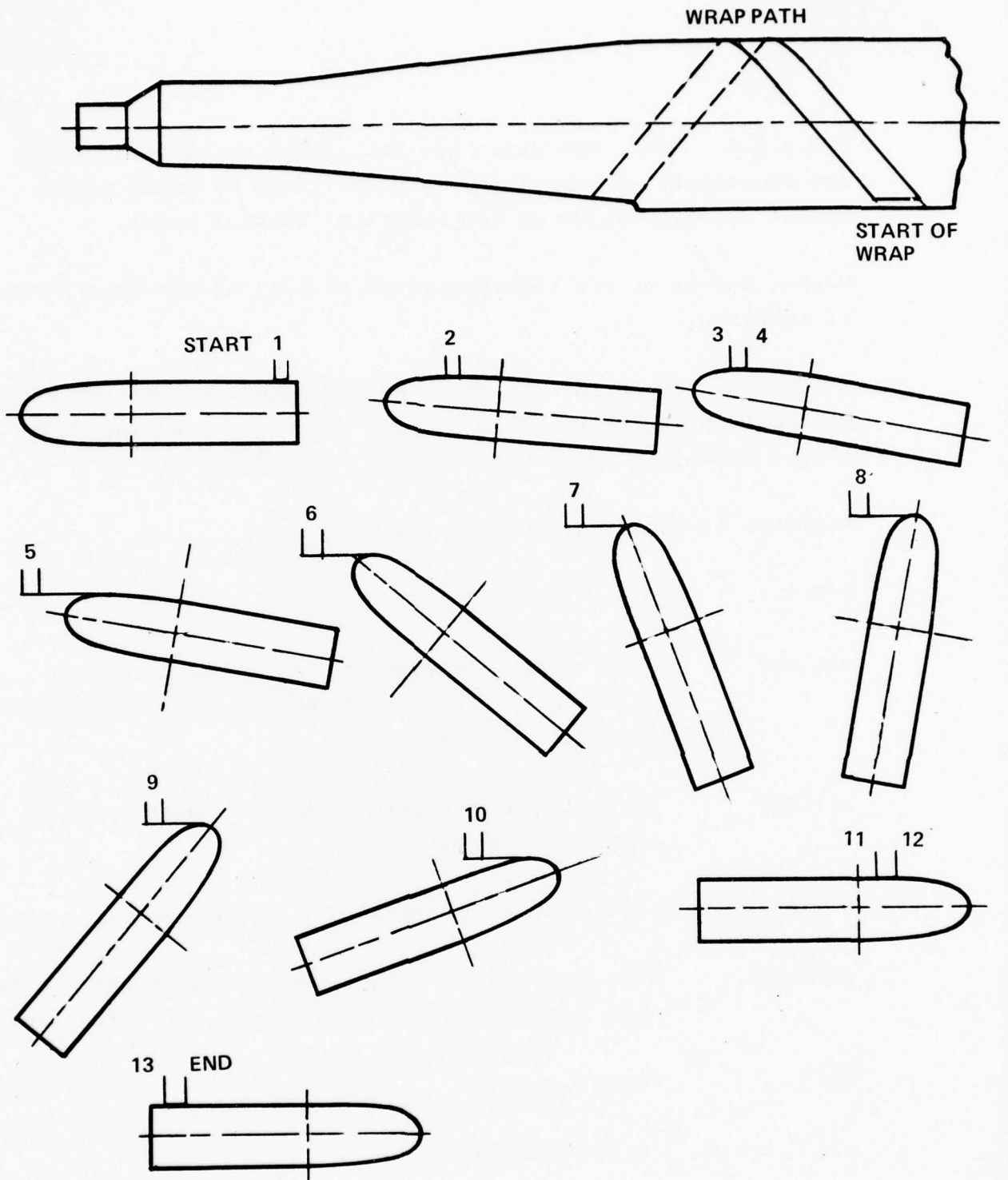

Figure 78. Digitized Points for Cross-Ply Wrap

5-5.3.2.5 After the axis have been lined up at each point, the coordinate axis positions are digitized by means of the Manual Execute button on the numerical control panel.

Output can be to the teletypewriter as well as the tape punch, if required.

5-5.3.2.6 The print out of a leading edge torsion wrap program is shown in Table 15. This program was made using the digitizing techniques just described in 5-5.3.2.1.

Analysis of the program is as follows:

5-5.3.2.7

G01 G90	Information entered by the keyboard and CRT sets the system in contouring mode with absolute coordinate departures.
X63239Y	Position of the head above the surface at the start of the pass.
Z28700	Position of the head at the start on the surface.
G04F200	Two second time delay to ensure that the Z axis has completed its move prior to the M functions.
M62	Auto head ON.
M74	Tape clamp OFF.
M72	Flexing placement foot ON.
G04F100	One second time delay to allow good adhesion of tape to surface.

BEST AVAILABLE COPY

G71G99
X63239Y49344Z39875A0C12670D179459
Z28729
G74F239
M62
M74
M72
G74F139
X66159Y45344Z28652C12619A1D-178358
Y68959Y41774Z28952C12619A1D-177725
M73
M66
X68959Y41773Z29051C12619A1D-177725
X72586Y36774Z29051C12619A1D-177724
X72786Y38774Z32351C12619A1D-142226
X73186Y41684Z34371C12619A1D-129944
X73486Y45344Z34371C12571A1D-82232
X73786Y48664Z33371C12571A1D-52229
X74186Y51754Z32271C12572A1D-22219
X74537Y52674Z28871C12629A1D-9538
X74536Y52674Z28871C12629A1D-9538
M72
M83
M67
X72207Y44675Z28272C12591A1D-825
X82807Y39575Z28372C12592A1D-359165
M75
M63
X82807Y39575Z28872C12592A1D359165
X86407Y34575Z37872C12592A1D359165
M72

TABLE 15. - PRINT OUT OF
LEADING EDGE WRAP PROGRAM.

X 66159 Flexing placement foot OFF

M66 Pay off reel full torque ON. These are entered just prior to lifting off the surface. The pay off reel full torque gives good back tension for the wrap operation, but is not desirable at the start of the pass.

X 68959
TO
X 74536 is the wrapping done in a series of digitized points with approximately 30° of rotation of the D axis between each.

M72 Turns flexing placement foot ON now that it is back on the surface.

M80 Tape shear. On this pass it happened to coincide with the touch down point.

M67 Turns pay-off reel full torque OFF. Too much back tension will prevent the tape from feeding through at the end of the pass, to bring the cut edge to the center of the placement foot, ready to start the next pass.

X 79097 Starts movement to run out cut length of tape.

X 82807 Bring the placement foot to the end of the pass.

M75 Tape clamp ON.

M63 Auto Head OFF.

X 8280 Lifts the placement foot from the surface.

M02 End of Program.

5-5.3.2.8 To summarize this wrap program, it can be seen that the one wrap has needed 31 blocks of information. A blade lay-up program will need to repeat this type of pass many times over. Some digitizing and programming short cuts will be required.

5-5.4 Programming Optimization - A number of programming short cuts became evident during the final phase of this Contract.

The leading edge torsion ply wrap described in 5-5.3.2.7 is a typical path which will be repeated many times.

5-5.4.1 By digitizing and programming with machine axis zero positions coinciding with the blade axis, use of the mirror image facility of the control would reduce the amount of digitizing required. Also by using the G98 off-set feature, a number of adjacent wraps could be achieved from one digitized path without extensive program editing.

5-5.4.2 Figure 79 shows helicopter blade tooling requiring 45° torsional wraps in both directions.

It is assumed that the tooling dimensions in wraps 1, 2 and 3 are similar and that mirror image wraps in the opposite direction, 1M, 2M and 3M can be achieved with the same program since the amount of movement ($\pm 1/2"$) of the placement unit, under the tape head, will compensate for small dimensional differences.

5-5.4.2.1 Axis zero positions are established as shown in Figure 79 with "X" 0 at Station 0 of the blade. This would be done using a G98 off-set.

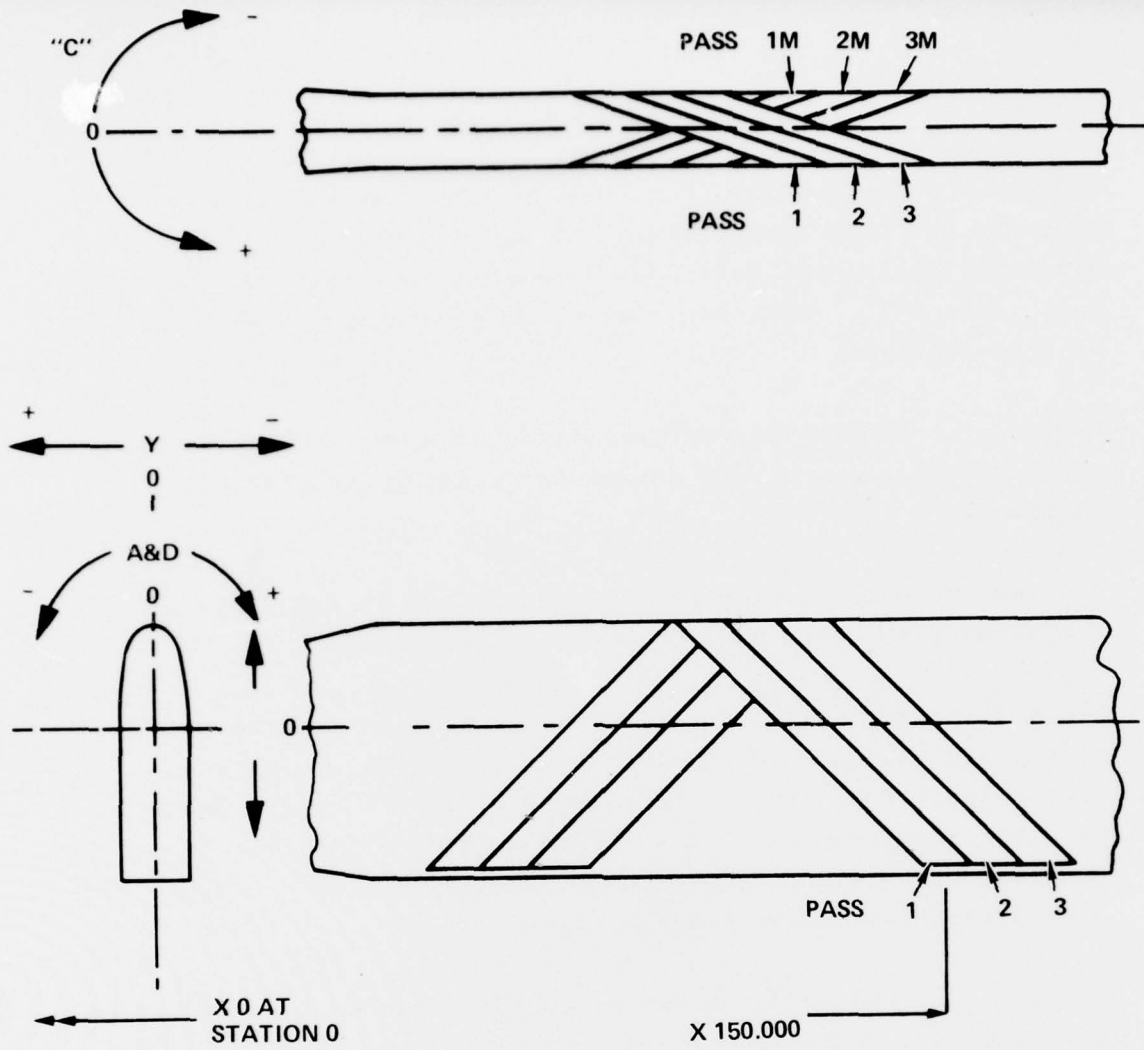

Figure 79. Torsion Wrap Programming

5-5.4.2.2 The path of wrap No. 1 is digitized.

By using the same program, with the same absolute coordinates but prefixing each pass with a G98 "X" axis off-set, wraps No. 2 and No. 3 can be achieved.

5-5.4.2.3 Similarly the opposite hand wraps 1M, 2M, and 3M can be done by changing the "Y", "C", "A" and D axis sign reversal switches.

5-5.4.3 This sort of program optimisation should reduce the time taken to set up programs for new tooling.

5-5.4.4 Another programming simplification would be the grouping of "M" functions to reduce the number of blocks requiring to be entered during digitizing. For example, in the torsion wrap in 5-5.3.2.7, a group of M62, M74, M72 occurs. By having one M function operate these three, in sequence if necessary, and also put the G04F100 time delay in at the end, digitizing time would decrease, and the amount of program proofing would be reduced.

These M function grouping routines could be done in the control by developing the required software.

The reliability and capabilities of the ATLAS machine had been shown at the Demonstration (covered in Section 5-4). Final qualification of the machine was subject to running the tests, as stated in the Performance Test Plan, Appendix III. The two significant tests, the Flat Pattern Lay up and the Spiral Wrap on the helicopter blade mock up were done.

5-6.1 Flat Pattern Layup - The basic layup pattern used is shown in Appendix III, Figure 95. The absolute coordinates for this pattern were changed slightly. Due to the $\pm 1/32$ " tolerance of the 3" wide glass epoxy tape, the programmed dimension between successive passes was increased to 3.050 to ensure that there would be no overlaps in the layup.

5-6.1.1 The rigid teflon faced placement unit was used to do this layup. To check the repeatability of the system, the program was run through two times. Measurements were made to check the dimensional changes between the first and second layups.

Figures 80 and 81 show the layups.

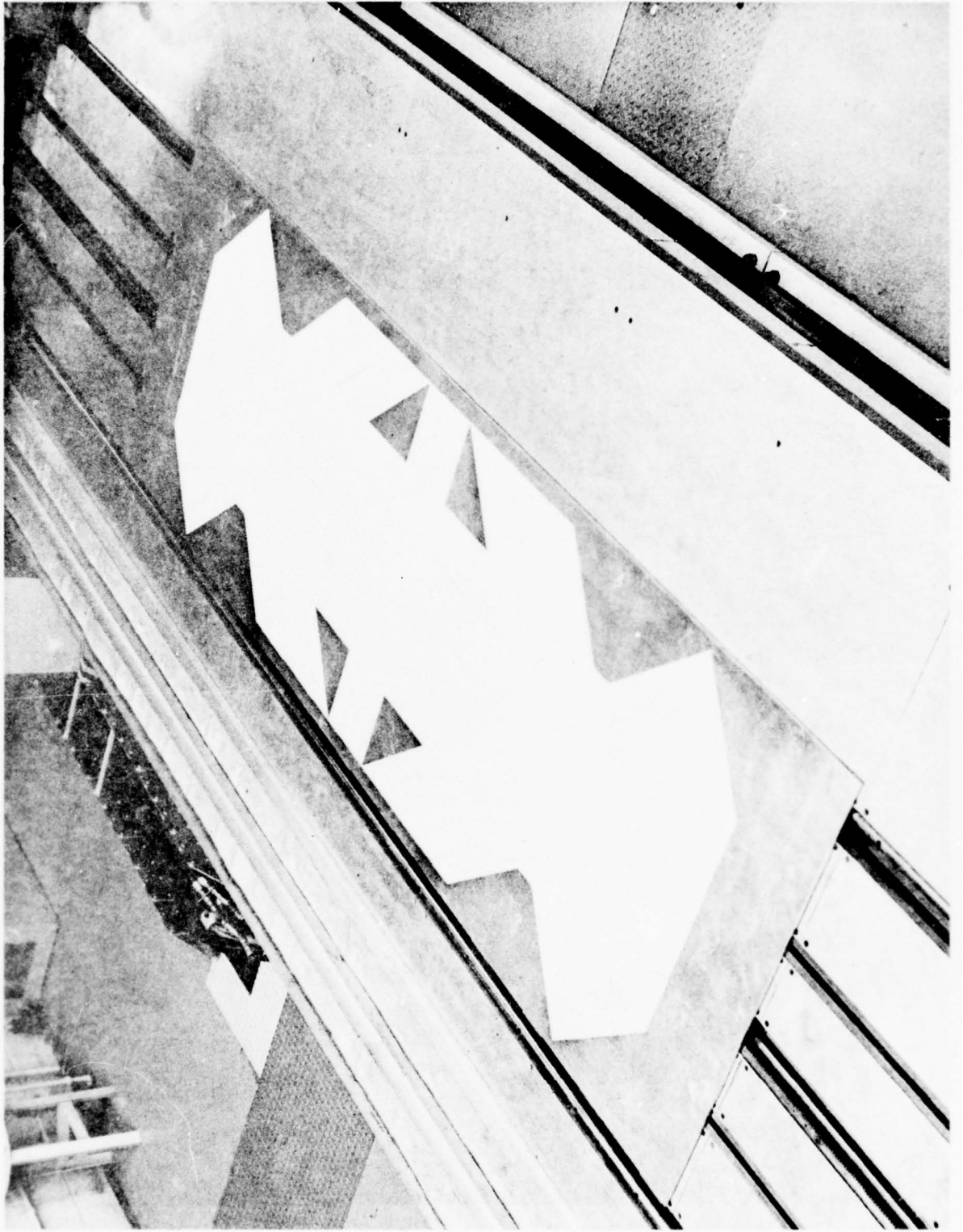

Figure 80. Performance Test Plan Flat Layout

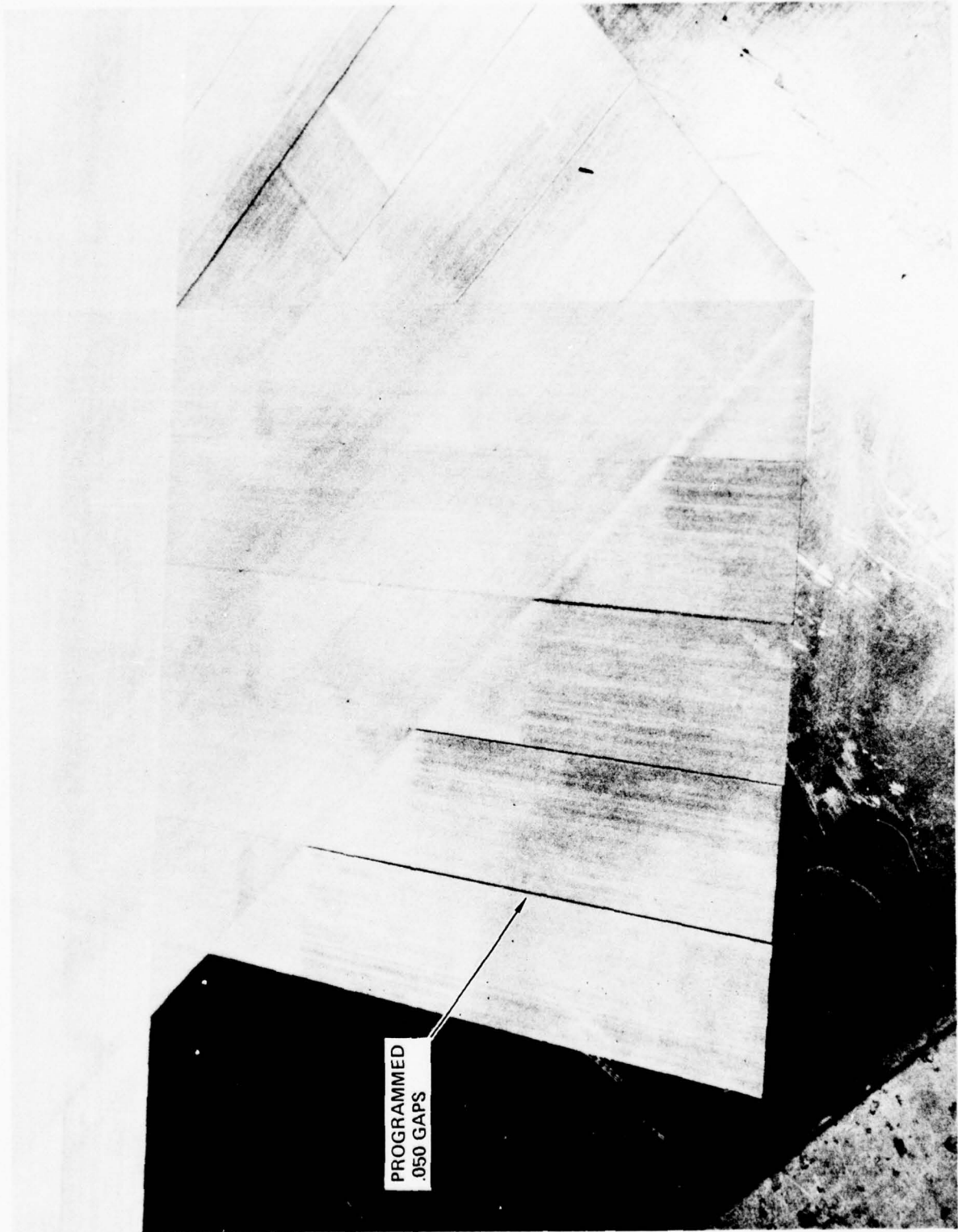

Figure 81. Performance Test Plan Layout

5-6.1.2 Measurements of the repeatability between the two layups were made using a graduated magnifying glass.

The measurements were done at the ends of each of the 31 passes. Where the second ply was shorter than the first, the difference measurement was given a - ve* sign. (* end variance)

Repeatability of location in sideways direction between the first and second layup was also measured at points one inch from the start and end of each pass.

5-6.1.3 The results are shown in Table 16.

Table 17 is an analysis of the results, showing that on average the repeatability is in the order of $\pm .010$ ".

The higher degree of repeatability of the END CUTS is due to the fact that the machine stops while the shear cuts the tape, then moves on by the programmed cut-off length to complete the pass. The tape remains in a tensioned and guided state.

5-6.1.4 Placement errors are created at lift-off at the end of a pass and replacement at the start of a pass in a new direction.

5-6.1.5 Complete uniformity of the gaps between the passes had not been expected. With tape width tolerances of $3" \pm 1/32$ as a commercial standard, the ability to layup with no overlaps to $.020$ " gaps is not possible.

5-6.1.5.1 Figure 82 shows the possible layup accuracy of both the tape and the tape guidance systems taken to their extreme range.

If the tape can be 3.030 " wide, then the tape guidance must be made to 3.030 " to suit.

May 29, 1974 - ATLAS REPEATABILITY CHECKS. TWO PLY ON FLAT PATTERN LAYUP

PASS NO.	START	END	START LOC.	END LOC.
1	-15	-20	10	20
2	+15	0	15	20
3	+15	-15	10	10
4	+10	0	5	5
5	0	0	0	10
6	0	0	5	10
7	+10	0	0	0
8	- 5	0	0	10
9	-20	0	0	5
10	0	0	0	0
11	- 5	0	0	5
12	-15	0	5	0
13	-30	0	0	0
14	0	0	0	10
15	+10	0	5	0
16	0	0	5	10
17	+ 5	0	5	5
18	0	0	0	0
19	+10	0	0	0
20	-10	0	10	0
21	+10	0	5	10
22	0	0	5	0
23	+10	0	0	10
24	0	0	0	5
25	+10	0	10	0
26	-10	0	0	0
27	+15	0	0	0
28	-15	0	15	20
29	+ 5	-20	0	20
30	+10	-10	35	0
31	0	+10	0	15

Numbers represent difference in .001" between first and second ply at the end of each laydown pass

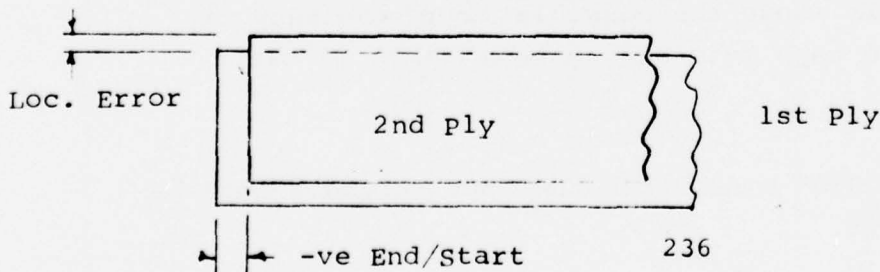

TABLE 16.

May 29, 1974 - REPEATABILITY CHECKS. TWO PLY ON FLAT PATTERN LAYUP

	25		Numbers represent difference
BEGINNING	20		in .001" between first and
END	15	XXX	second ply at the ends of
	10	XXXXXXXXXX	each laydown pass.
	+ 5	XX	
	0	XXXXXXXXXXXX	
	- 5	XX	
	10	XX	
	15	XXX	74% within <u>+10</u>
	20	X	
	25	X	
	20		
END	15		
CUT	10	X	
	+ 5		
	0	XXXXXXXXXXXXXXXXXXXXXXXXXXXX	
	- 5		
	10	X	94% within <u>+10</u>
	15	X	
	20	XX	
	25	X	
BEGINNING	20		
LOC.	15	XX	
	10	XXXX	
	5	XXXXXXXXXX	
	0	XXXXXXXXXXXXXXXXXXXX	94% within <u>+10</u>
	25		
END	20	XXXX	
LOC.	15	X	
	10	XXXXXXXXXX	
	5	XXXXX	84% within <u>+10</u>
	0	XXXXXXXXXXXXXXXX	

TABLE 17.

Figure 82 shows two passes done using tape on its lower width limit 2.970". The tape favors one side of the placement guidance.

On turn-around for the second pass, the tape is assumed to remain in contact with the same guidance flange.

5-6.1.5.2 The resulting gap between the two passes would be .12". Also this assumes no allowable inaccuracies in the rotation of the tape placement head or in positioning accuracy of the machines motions.

5-6.2 Root-End Wrap - A new program was developed to make a single wrap towards the root-end of the mock up mandrel. The program was digitized using the "bow-tie" and mylar strip unit described previously, and included "M" functions to operate the flexing placement foot.

The program for the 2 1/2 revolutions of the mandrel had 65 blocks of axis coordinates and 18 blocks of other information. It was interesting to note that the program punched tape was over 2 times the length of the tape path of the 2 1/2 revolution wrap layup.

5-6.2.1 The wrapping of two passes on the digitized path was witnessed by AVSCOM personnel:

Slitting of the tape, using the slitter and dancer system, was done throughout the layup. Figure 83 shows the slit tape in position on the mock-up. The tape was accurately located with reference to the black line tape remaining under it, showing that the method of digitizing produced accurate layup.

5-6.2.1.1 The second ply of the layup showed good repeatability, similar to that achieved on the Flat Pattern Layup.

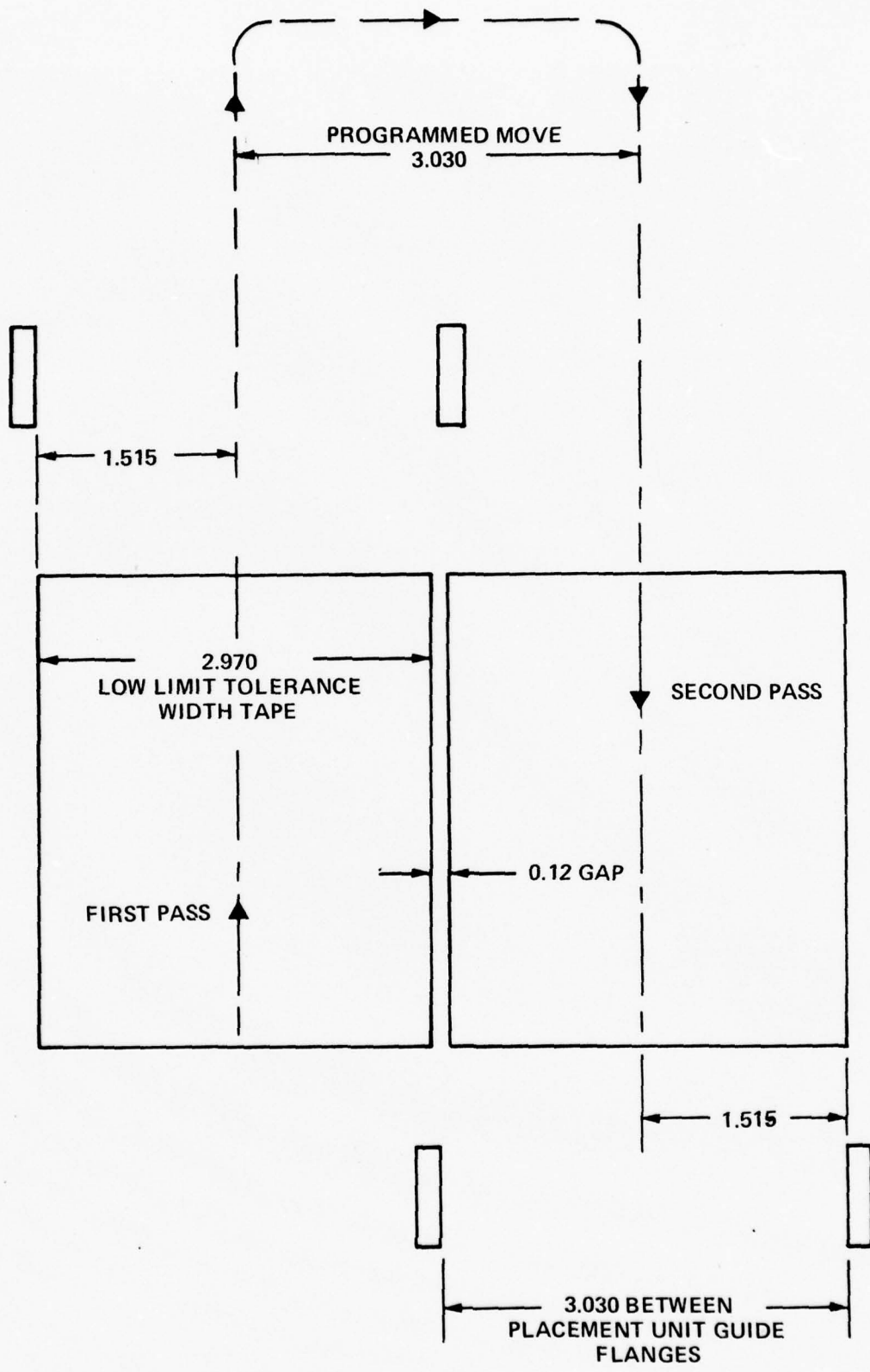

Figure 82. Effect of Tape Width Tolerance

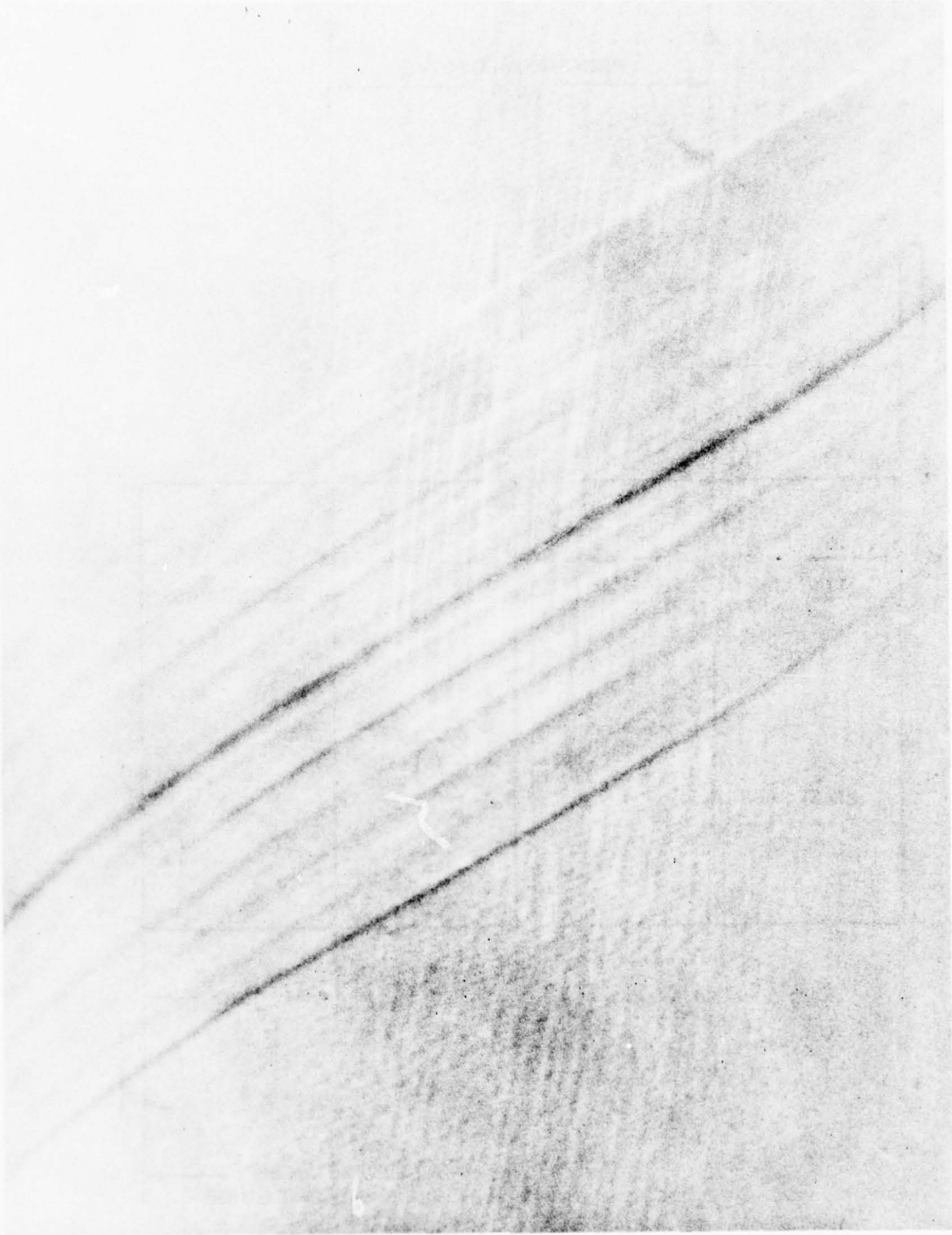

Figure 83. Slit Tape On Root End Mockup

5-6.2.1.2 The inability of the flexing placement foot to properly conform to the surface at the end of each pass resulted in some torn backing paper strips of the slit tape.

5-6.2.2 It was concluded that the ATLAS machine had adequately demonstrated its ability to perform the root-end wrap within the limitations of the placement unit. Further development work on placement devices would be required in order to fully utilize the ATLAS machines potential.

APPENDIX I

TECHNICAL SPECIFICATIONS
FOR A

NUMERICALLY CONTROLLED TAPE
LAYUP MACHINE FOR MONO-
FILAMENT FIBER STRUCTURES

TECHNICAL SPECIFICATIONS
FOR A
NUMERICALLY CONTROLLED TAPE
LAYUP MACHINE FOR MONO-
FILAMENT FIBER STRUCTURES

PREPARED BY: *Grant & Casello*
APPROVED BY: *G. Chandler*
CONCURRENCE: *Les Lee*
M. J. Kolmer

EQUIPMENT ENGINEERING
THE BOEING COMPANY
VERTOL DIVISION
MAIL STOP P36-78
P.O. BOX 16858
PHILADELPHIA, PA. 19142

EES-7-376
ORIGINAL : 07-10-69
REVISION 'C': 10-23-69

1.0

INTRODUCTION

This specification defines a multi-axis numerically controlled machine for the automated layup of pre-impregnated monofilament fiber tapes in prescribed paths over complex contoured surfaces. The tape will be applied by means of a dispensing head automatically oriented to a position normal to the work surface and carried through the prescribed path as a result of coordinated machine functions.

In addition, auxiliary machine functions are to be provided to automatically shear tape to predetermined lengths.

The anticipated applications, on both a developmental and a production basis, include helicopter rotor blade spars, V/STOL blade spars, and a variety of airframe structures.

1.2

Drawing EE-1331 is included in this specification to indicate the overall concept of the machine and to identify the principal machine assemblies, required motions and axes of travel and rotation, lengths of required motions, parking requirements, and associated tooling concepts.

1.3

These specifications and the above referenced drawing are not intended to be restrictive. Alternate concepts are solicited providing that they will meet the intent of these specifications, are within a reasonably attainable state of the art, are coordinated with Boeing-Vertol prior to submittal of the proposal, and are included in writing as a part of the bidder's proposal.

2.0

REQUIREMENTS

2.1

The machine shall apply and cut preimpregnated fiber tape in programmed paths onto work surfaces having contours varying from flat sections to compound curvatures with minimum radius of two inches.

2.2

The feed, application, and shear mechanisms shall be on a tape dispensing head carried on a moving machine member.

2.3

The application head shall be maintained normal to the work surface along the path of application.

- 2.4 The machine shall be capable of applying tape in infinitely variable programmed paths in any direction by means of coordinated motions of up to five numerically controlled axes.
- 2.5 Application of the tape shall be possible on both the forward and return motions of the moving machine member.
- 2.6 Support tooling such as mandrels and molds will be furnished by Boeing-Vertol as tooling and is excluded from the scope of this specification.
- 3.0 DESCRIPTION
- 3.1 Configuration
- 3.1.1 Subject to the alternate concepts discussed in section 1.3, the machine shall be similar to a light duty, high speed gantry head vertical profile mill or router with multi-axis numerical control.
- 3.1.2 The machine shall include the following principal assemblies:
- 3.1.2.1 A fixed horizontal work table approximately 12" above the floor line and including longitudinal ways for the gantry head.
- 3.1.2.2 A horizontally driven gantry head having vertical ways and a cross rail moving in the vertical direction. The cross rail shall have ways and a saddle to provide transverse travel.
- 3.1.2.3 A tape dispensing head mounted on a rotary mechanism attached to the cross rail saddle.
- 3.1.2.4 A powered rotary headstock attached to one end of the bed and having a manually adjustable distance between the centerline of the headstock spindle and the top of the bed.
- 3.1.2.5 An idler rotary tailstock manually adjustable along the horizontal gantry head ways and having a manually adjustable distance between the centerline of the tailstock spindle and the top of the bed.
- 3.1.2.6 Three removable concave roller steady rests to align and support long tooling mandrels attached to the headstock and tailstock.

- 3.1.2.7 A multi-axis contouring numerical control system, and associated other controls, mounted on an operator's platform attached to and moving horizontally with the gantry head, to provide continuous operator surveillance.
- 3.2 Programmed Machine Functions
- 3.2.1 Longitudinal travel (X axis):
- 432 inches of working travel plus parking space for the gantry head. Feed rate range to be from 72 to 720 inches per minute with programmed acceleration and deceleration. Provisions shall be included to allow future field modular length extensions to approximately 600" travel.
- 3.2.2 Transverse travel (Y axis):
- 96 inches of working travel plus parking space for the cross rail saddle with the tape dispensing head in the normal vertical position. Feed range to be from 72 to 720 inches per minute with programmed acceleration and deceleration.
- 3.2.3 Vertical travel (Z axis):
- 36 inches of working travel plus parking space for the cross rail. Feed rate ranges to be from 15 to 150 inches per minute with programmed acceleration and deceleration.
- 3.2.4 Headstock rotation (A axis) and vertical adjustment:
- 360 degrees of rotation around the longitudinal (X) axis with a speed range of 1 to 10 R.P.M. The centerline of the headstock shall be manually adjustable from 10 to 30 inches above the bed. To be shared A axis with A₂.
- 3.2.5 Tape head tilting (A₂ axis):
- Plus or minus 45 degrees of rotation around the longitudinal (X) axis with reference to the normal vertical position of the tape head. To be a shared axis with A₁.
- 3.2.6 Tape head rotation (C axis):
- 360 degrees of rotation around the Z axis with a speed range of 1 to 10 R.P.M. The rotation shall be in both directions.

- 3.3 Tape dispensing head
- 3.3.1 The tape to be dispensed will be monofilament fiberglass, boron, carbon, or advanced fiber materials in the uni-directional configuration. It will be mounted on backing material and packaged on reels.
- 3.3.2 Tape thickness will range from .005 to .020 inches.
- 3.3.3 Tape widths will range from 1/2 to 3 inches.
- 3.3.4 The design effort shall investigate the feasibility of providing interchangeable heads or sub-assemblies to accommodate tapes ranging from 3 to 12 inches in width.
- 3.3.5 The head assembly shall tilt in the A_2 axis around the longitudinal (X axis) as described in section 3.2.5. The center of rotation shall be about the centerline of the application roll in order to reduce the programming effort.
- 3.3.6 The head assembly shall be rotatable in the X axis around the vertical (Z axis) as described in section 3.2.6.
- 3.3.7 A cutter blade assembly shall be provided to shear the tape by auxiliary control function commands. The cutter blade shall be preset and locked in place in one degree increments to plus or minus 60 degrees from the longitudinal axis of the tape.
- 3.3.8 The design effort shall investigate the feasibility of providing an adjustable tape cutter blade assembly which will cut the tape from square to 45° in both directions with respect to the longitudinal axis. Activation, in one degree increments, shall be by an auxiliary function of the numerical control system.
- 3.3.9 A variable pressure shall be applied to the application roll by means of an air cylinder or equivalent electro-mechanical device.
- 3.3.10 A positive feed mechanism shall be provided to dispense and apply the tape to the work surface.
- 3.3.11 Provisions shall be made to minimize the effects of resin pickup on the various head components.
- 3.3.12 The design effort shall investigate the feasibility of compensating for tape inaccuracies by sensing the edge of the last tape laid and overring the programmed path to maintain the gap between adjacent tape edges within allowable tolerances.

- 3.3.13 The design effort shall investigate the feasibility of a means of locally heating the tape immediately prior to the application roll to improve the adhesion of the tape to the work surface.
- 3.4 Controls
- 3.4.1 The machine functions shall be controlled and coordinated by means of a multi-axis contouring (continuous path) numerical control system.
- 3.4.2 The required axes, travels, feed and rotational rates, and auxiliary control functions are specified in section 3.2.
- 3.4.3 It is anticipated that the required control system resolution will be .001 inch or coarser in order to achieve the high positioning speeds required.
- 3.4.4 Dual tape readers shall be provided to accommodate the anticipated long length programs.
- 3.4.5 The control system shall be provided by Bendix, Bunker-Ramo, or General Electric. Specific determination of make, model, features, and accessories will be accomplished under the design phase of this program.
- 3.4.6 The design proposal shall include a line item for the furnishing of an APT III, Fortran IV post processor, compatible with the I.I.T. Research Institute post processor guideline, and conforming to NAS 938, 943, and 955 as applicable. The post processor shall be capable of out-putting machine motions and function commands which allow the machine to be operated in an optimum manner. An I.B.M. 360-65 computer will be used by Boeing-Vertol for N.C. tape preparation.
- 3.4.7 The design effort shall investigate the substitution or provisions for future retrofitting of direct numerical control (D.N.C.) as an alternate to the specified conventional numerical control in order to minimize the problem of excessive tape lengths. Other areas to be investigated will include self programming and tape preparation from actual machine operations.
- 3.5 Construction
- 3.5.1 All equipment proposed against this specification shall be of the high quality associated with aerospace numerical control equipment, and shall be designed for continuous service, long life, and ease of maintenance and replacement.

- 3.5.2 Consideration shall be given to the fact that the extreme rigidity and positioning accuracy of a typical aerospace gantry head profile mill is not required in this application.
- 3.5.3 The gantry head shall be designed to provide the required rigidity, maximum obtainable positioning speed, and minimum practical acceleration-deceleration times using minimum weight. Aluminum or magnesium construction is anticipated.
- 3.5.4 The machine ways shall be designed for minimum friction by the use of recirculating ball bushings, ball or roller packs, or similar methods.
- 3.5.5 Any oil leakage, or film, or oil mist in the working zone of the machine will be unacceptable because of possible contamination of the tape. The use of hydraulic systems shall be avoided if at all possible. Air operated components requiring oil mist lubrication are equally undesirable. The use of electric servo-drives, electro-mechanical actuators, and non-lubricated air components is highly desirable.
- 3.5.6 Wiring and similar connections to the major moving machine assemblies shall be by Gleason Reel "Power-Traks" or equivalent.
- 3.5.7 Interconnecting wiring, wire troughs, hoses, and similar items shall be provided for in the design so as to minimize on-site fabrication during installation.
- 3.6 Operating environment and available utilities:
 - 3.6.1 The machine will be installed in an adhesive layup area having a controlled environment. The nominal temperature will be 70 degrees, relative humidity 40%, and air filtration will be used.
 - 3.6.2 The available utilities will include 460-3-60 electrical power having allowable voltage fluctuations of $\pm 10\%$, compressed air at 80 P.S.I. minimum pressure and domestic water at 65°-85°F. depending upon the season.
- 3.7 Electrical requirements:
 - 3.7.1 All motors 1/2 H.P. and over shall be 230/460-3-60, initially wired for 460 volts.

- 3.7.2 Equipment shall include motor starters and disconnect switches.
- 3.7.3 Motors 15 H.P. and over shall be provided with power factor correcting capacitors.
- 3.8 Applicable specifications:
- MIL-D-1000 Drawing standards.
 - NAS 938 Machine axis and motion nomenclature.
 - NAS 943 Continuous path numerical control systems.
 - NAS 958 Punched tape standards.
 - E.I.A. Electrical construction standards.
 - E.I.A. Bulletin SP621 - tape standards.
 - I.I.T. Research Institute Post Processor Guideline.
 - N.M.T.B.A. Mechanical standards.
 - N.M.T.B.A. and N.E.M.A. electrical standards.
 - J.I.C. Hydraulic and Pneumatic standards, as applicable.
- 4.0 PERFORMANCE
- 4.1 Positioning accuracy, in the X axis, shall not exceed plus or minus .0025 inches per foot deviation from the tape command, with a maximum cumulative error of plus or minus .050 inches, and a repeatability of plus or minus .0025 inches.
- 4.2 Positioning accuracies, in the Y and Z axes, shall not exceed plus or minus .0025 inches per foot deviation from the tape command, with a maximum cumulative error of plus or minus .010 inches, and a repeatability of plus or minus .0025 inches.
- 4.3 The gap between adjacent tape edges shall not exceed .020 inch. Unless specifically programmed, any overlap between adjacent tapes is unacceptable.

- 5.0 ACCEPTANCE TESTING:
- 5.1 The machine will be checked out by Boeing - Vertol personnel at the manufacturer's plant for compliance with these specifications prior to shipment.
- 5.2 A complete checkout will be repeated after installation at Boeing - Vertol.
- 5.3 Details of the checkout procedure will be developed as part of the design effort. It is anticipated that the checkout will fall into the following two categories:
- 5.3.1 Dimensional and performance checks of the machine proper to the requirements defined in sections 3.2 and 4.0, measured from a suitable reference point on the tape head assembly.
- 5.3.2 A check of actual tape layup on a mandrel or mandrels to be furnished by Boeing-Vertol, using either selected production tape or higher accuracy tape of another type, to be furnished by Boeing-Vertol.
- 6.0 SUPPORTING DOCUMENTATION
- In addition to the drawings required for the fabrication and assembly of the machine, the following supporting documentation will be required:
- 6.1 Operator's manual
- 6.2 Maintenance manual, including maintenance instructions, replacement parts lists, recommended spare parts lists, preventative maintenance schedules, data on purchased components principal drawings, and wiring and piping diagrams.
- 6.3 Installation drawings and specifications including accurate utility requirements, weights, and shipping information.

- 6.4 Detailed test procedures for acceptance testing.
- 6.5 Six copies or one reproducible master of each of the above documents will be required.
- 6.6 The bidder's proposal shall include a sketch showing the principal assemblies and overall dimensions. It shall include unusual installation requirements, such as pits or special foundations. The types and approximate quantities of required utilities shall be indicated, together with special utility requirements, such as instrumentation dry air.

APPENDIX II

TEST REPORT

EVALUATION OF PNEUMATIC PLACEMENT ROLLER
CONTOUR COMPLIANCE CHARACTERISTICS

TEST REPORT

Evaluation of Pneumatic Placement Roller Contour Compliance Characteristics.

Purpose

The purpose of the tests is to provide qualitative data concerning the ability of the roller to assume the shape of the surface it is bearing against. By specification, the roller must be able to comply to a minimum radius of two inches. It is felt that this represents the worst case that the roller will see in service, therefore it was decided to design a test fixture wherein it would be possible to visually observe the contact patch of the roller when subjected to a combination of varying inflation pressures and roller loadings while bearing against a curved surface with a two inch radius. The test fixture as it finally evolved is shown in Figure 84.

Test Setup

A welded steel frame is provided with a pair of plywood supports through which passes a 4 inch diameter clear acrylic tube. A lever type support structure is pivotally mounted beneath and parallel to the acrylic tube so that its frame is horizontal when the roller bears against the lower surface to the tube.

The tube has its upper half removed for some distance in order to eliminate distortion when viewing the roller/tube interface.

The roller support structure is arranged to provide a 5:1 ratio between the center of the roller contact patch and the loading

platform at the opposite end of the frame. The frame weight bias provides an initial 25 pound force at the roller contact patch when the frame platform is unladen.

Test Procedure

In order to provide data ranging across the roller operating spectrum, a series of eight tests were performed. These were broken down into two sets of four each. The first set was conducted using 10 PSIG inflation pressure while the second set was run using 20 PSIG inflation pressure. In order to insure that the pressures remained constant throughout the test, the valve core was removed and a pressure regulator connected to the valve stem.

Each set of tests consisted of loading the roller in increments of 25 pounds. Thus the first test in the series had the roller loaded to 25 pounds and the fourth in the series had it loaded to 100 pounds.

Yellow water based paint was applied to the portion of the roller that would be in contact with the acrylic tube. As the roller was brought to bear against the tube, the paint was displaced allowing the black rubber surface to appear. The paint formed a halo around the periphery of the contact patch thereby highlighting it and providing a clearly defined boundary to the patch.

Test Results

The results of the tests are shown in photographs Fig. 85 through 92. As can be seen, the contact patch area increases linearly with increased roller load the pressure at the patch remaining

constant, being approximately equal to the roller inflation pressure plus 2 PSI.

The amount of crowning or bulging of the roller 90° away from the contact patch reached a maximum of approximately 0.18 inches during test 4 (10 psi inflation pressure, 100 pounds load).

The roller did not exhibit any reaction to the imposed loads that would indicate the existence of one or more problem areas. Figures 93 and 94 show the roller under maximum compression (10 psi inflation pressure, 100 pounds load) and as can be seen, the transitions are smooth and gentle so that the tape and liner paper can be expected to follow the roller contour providing reasonable tension can be maintained on the tape/liner.

Conclusions

The tests proved the ability of the roller to comply with a two inch radial surface over a three inch width. Further, they showed the relationship between load and inflation pressure and their cumulative effect on roller compliance.

It can be concluded from the tests that using an inflation pressure of approximately 15 PSIG and a load between 50 and 75 pounds will provide reasonable compaction with good surface compliance in all but the most severe cases.

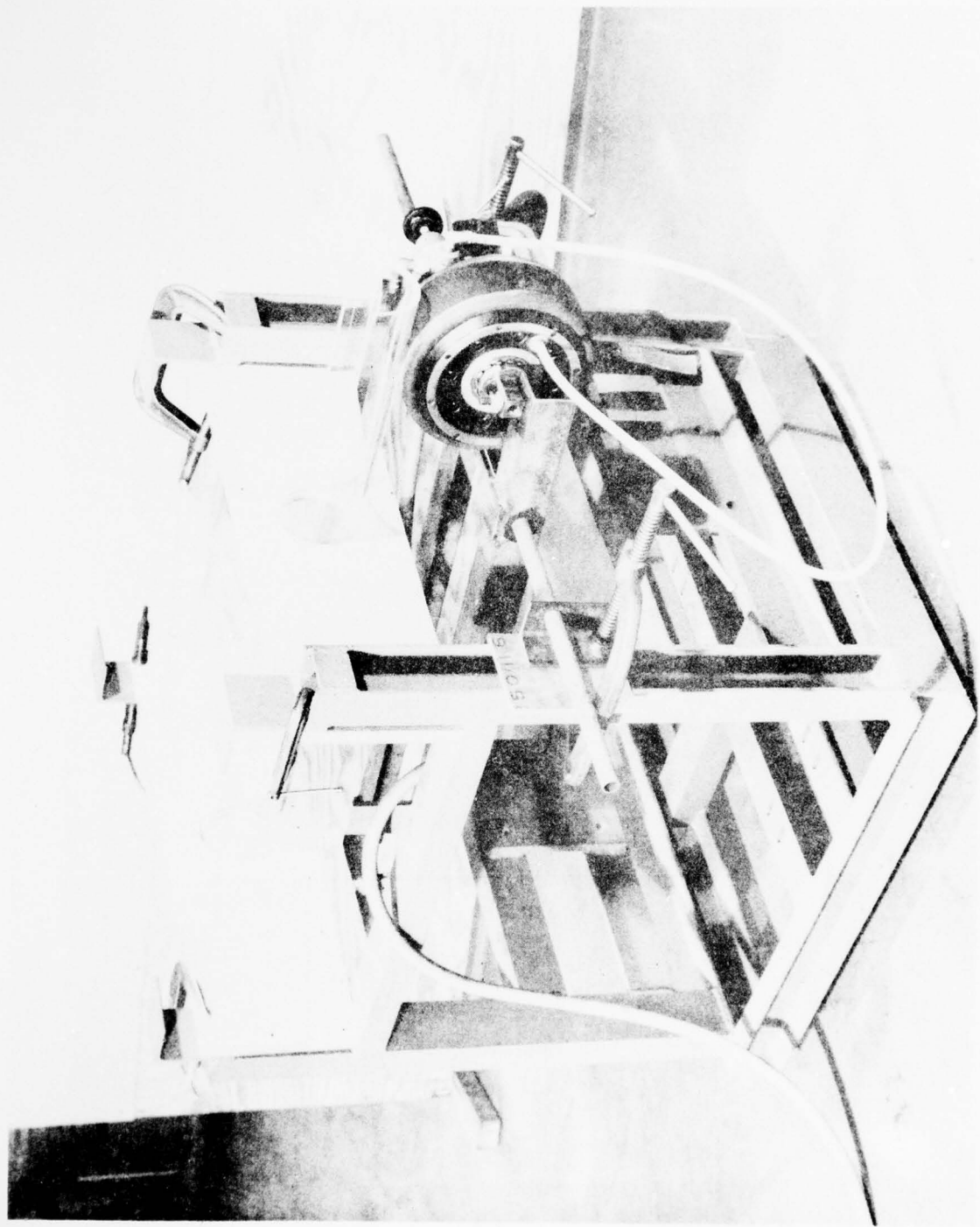

Figure 84. Pneumatic Placement Roller Test Fixture

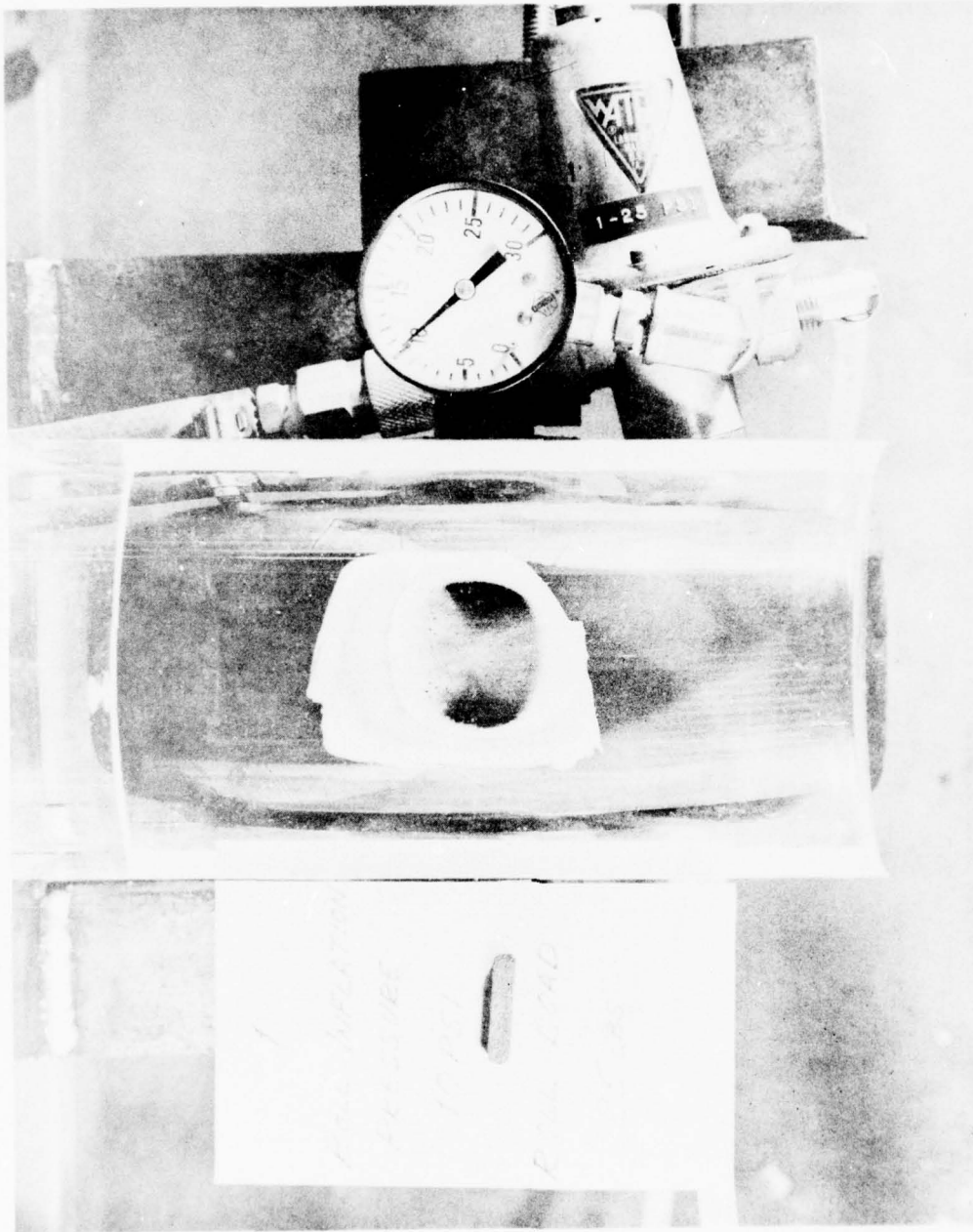

Figure 85. Test No. 1 Contact Patch

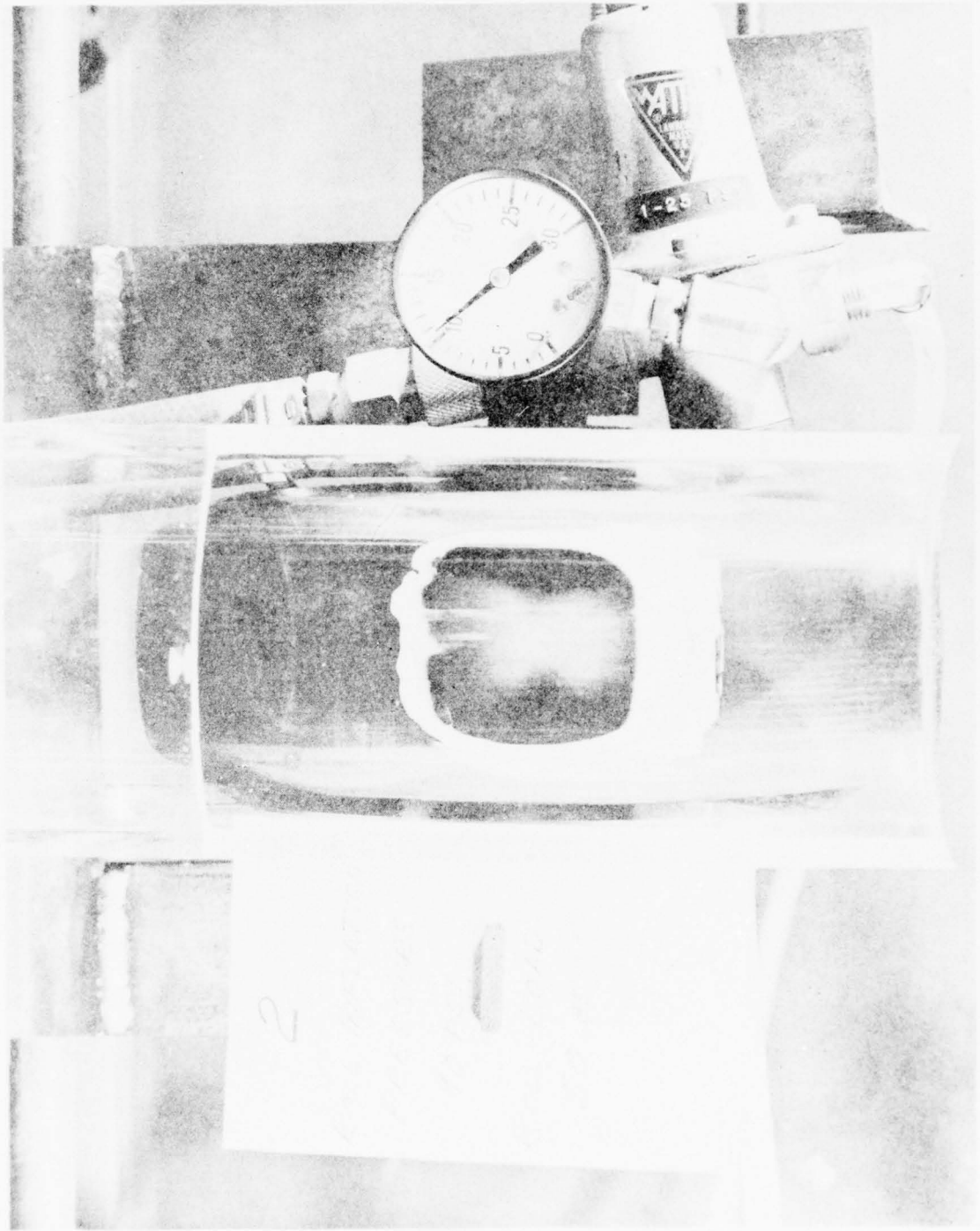

Figure 86. Test No. 2 Contact Patch

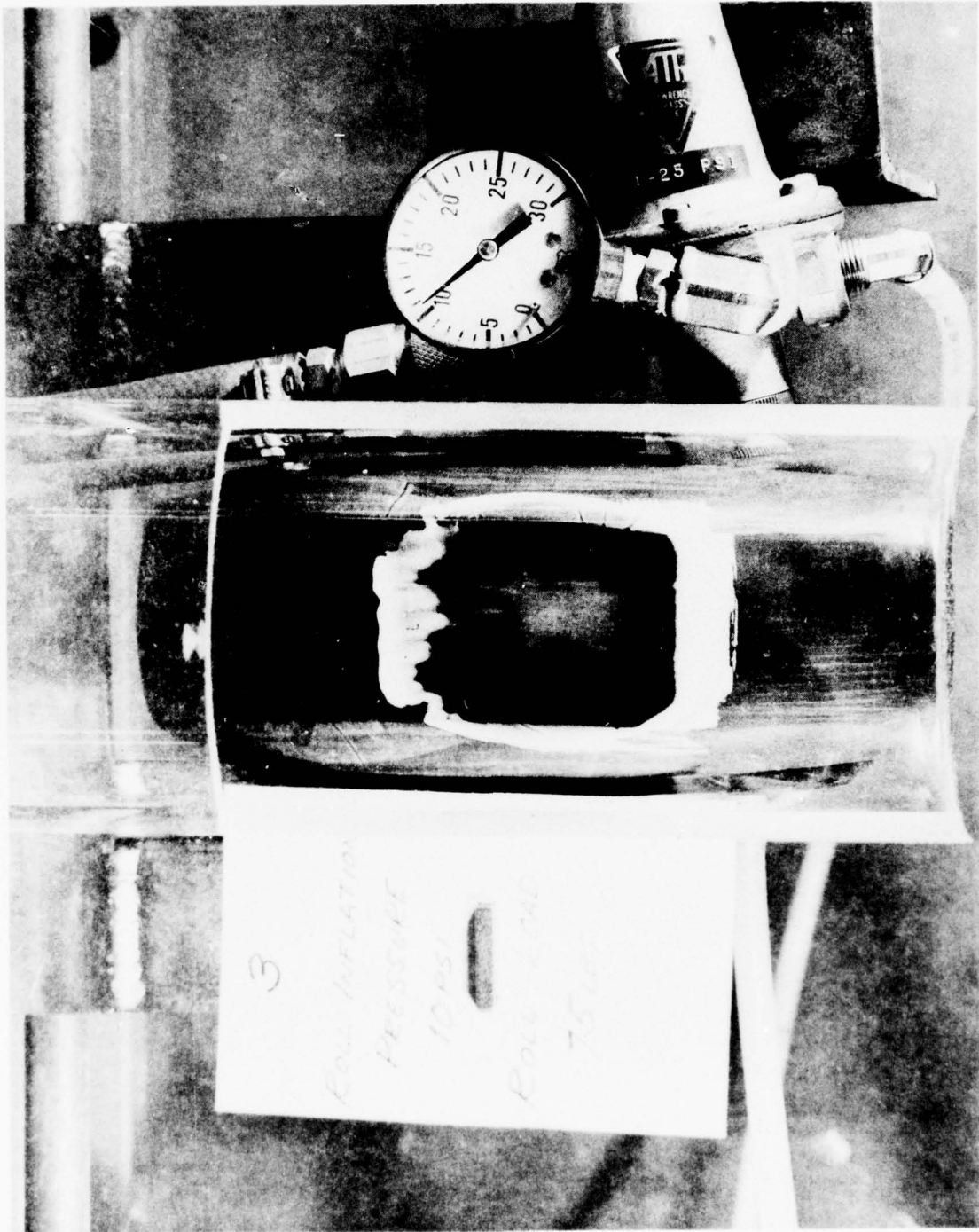
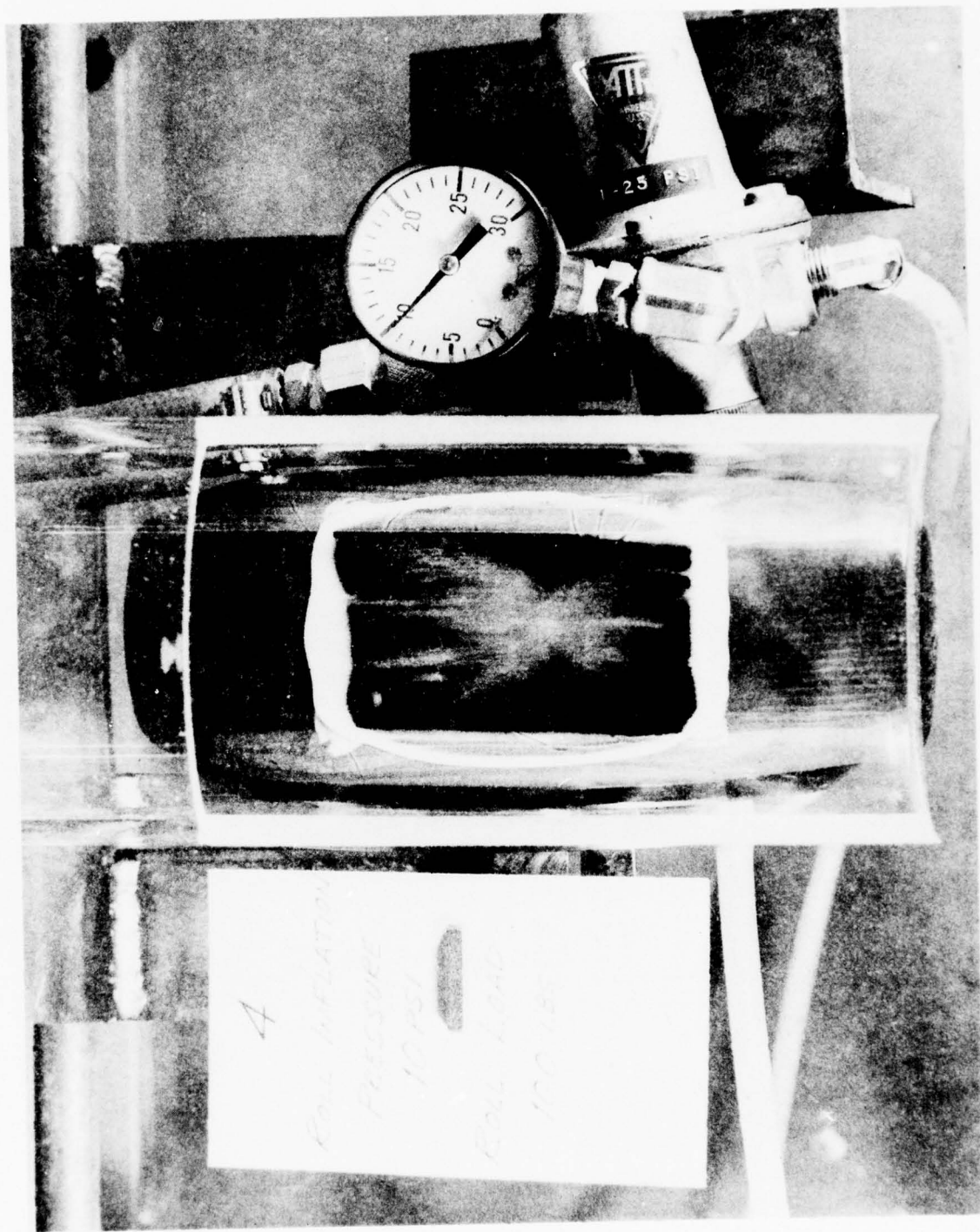

Figure 87. Test No. 3 Contact Patch



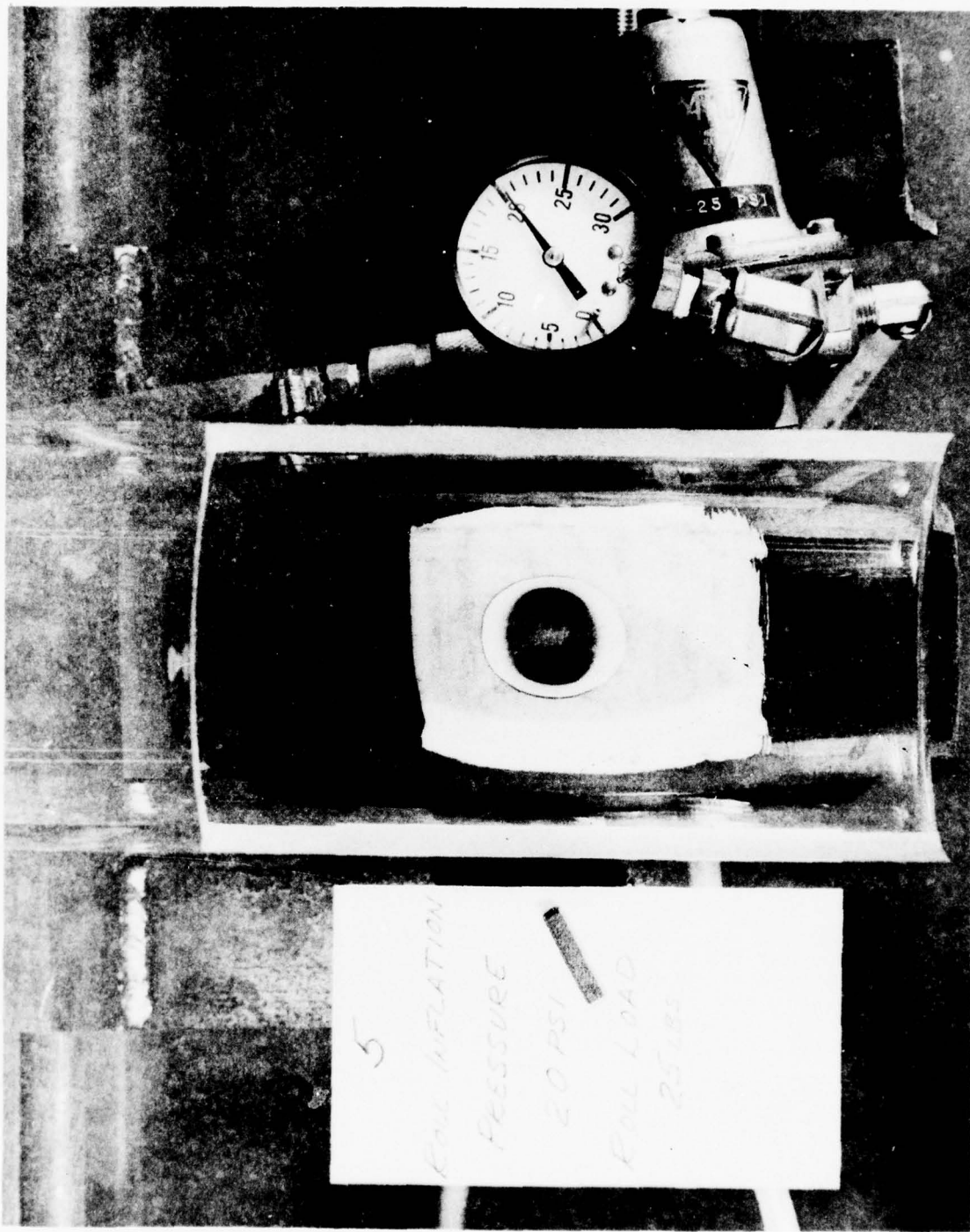
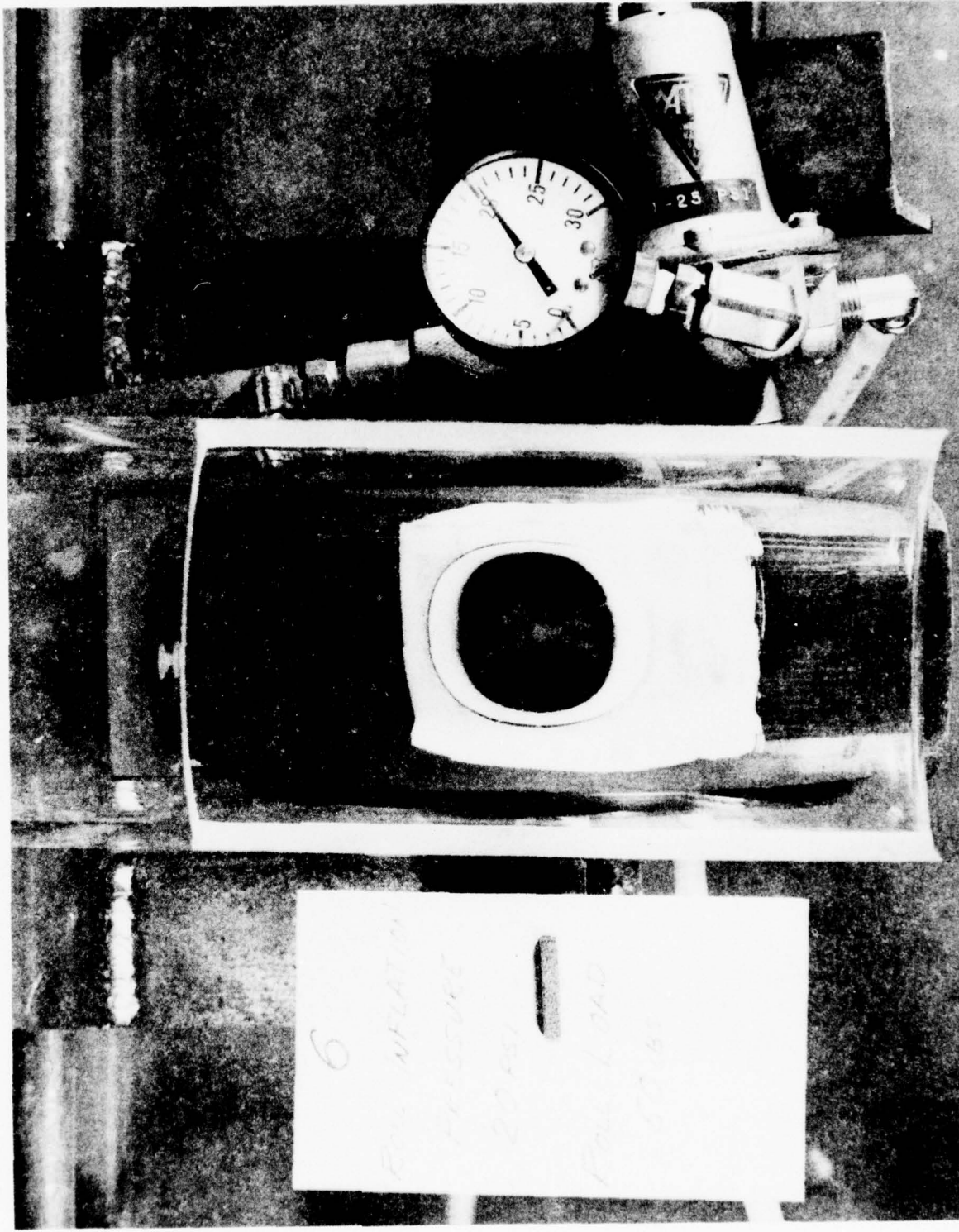
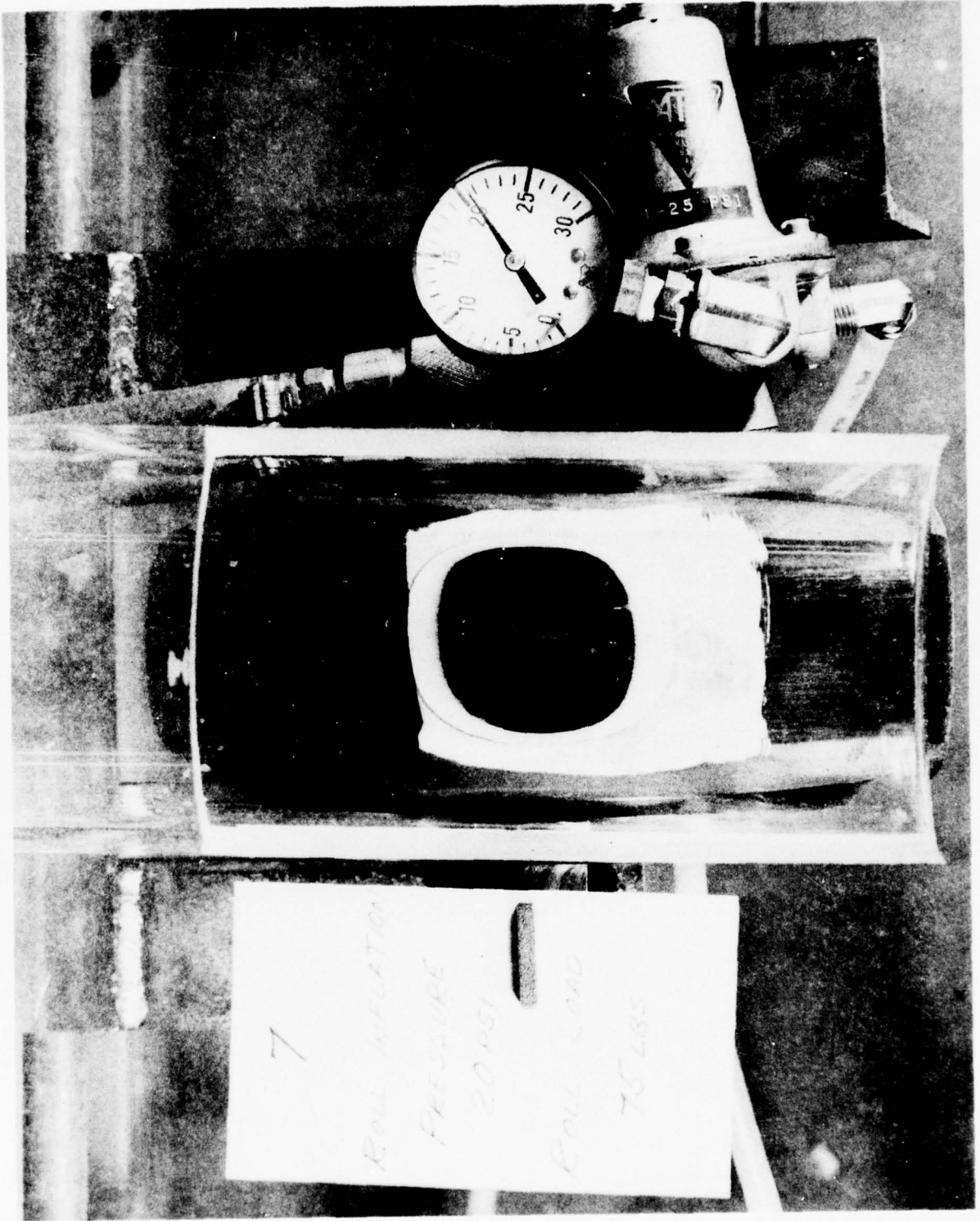

Figure 89. Test No. 5 Contact Patch





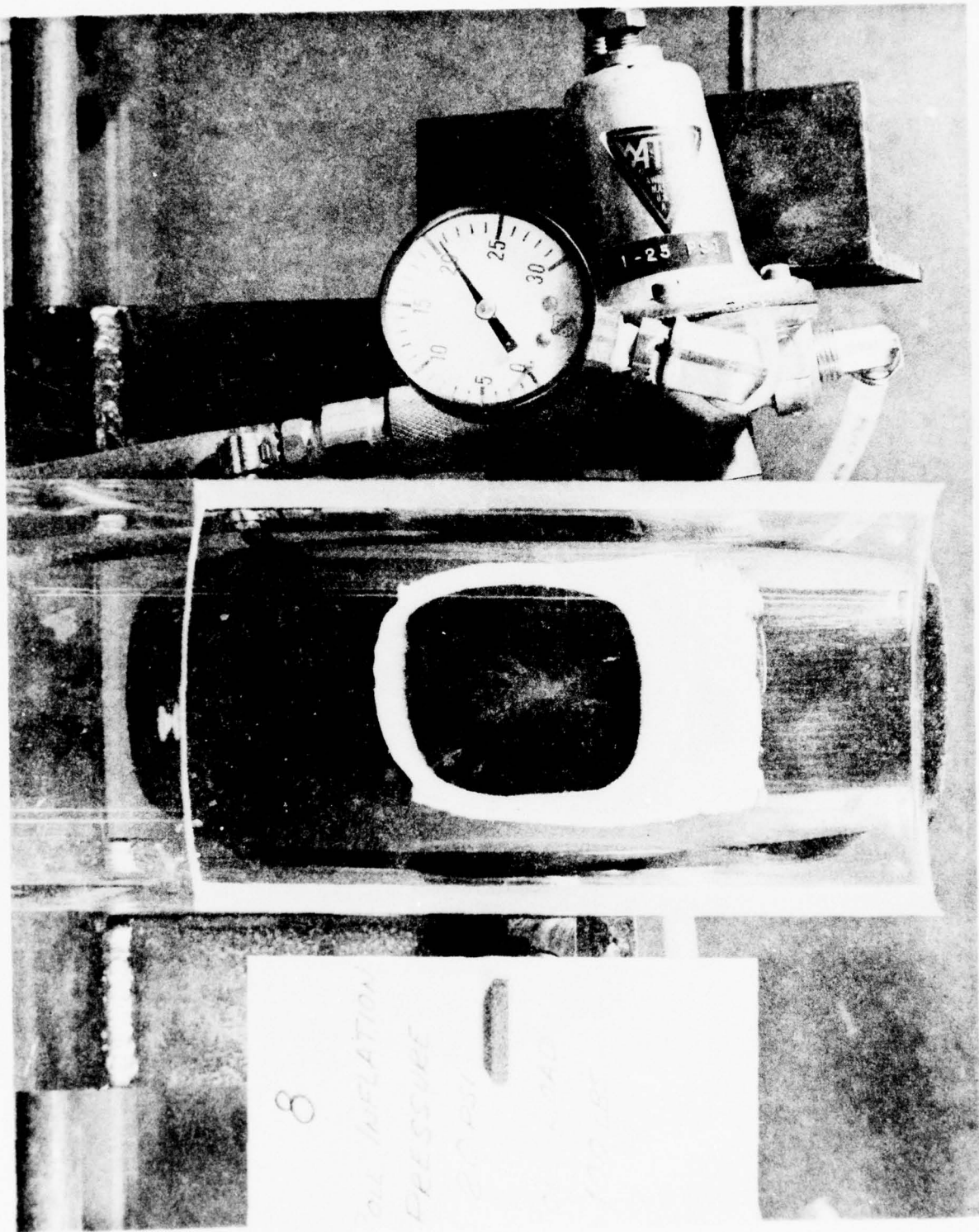

Figure 92. Test No. 8 Contact Patch

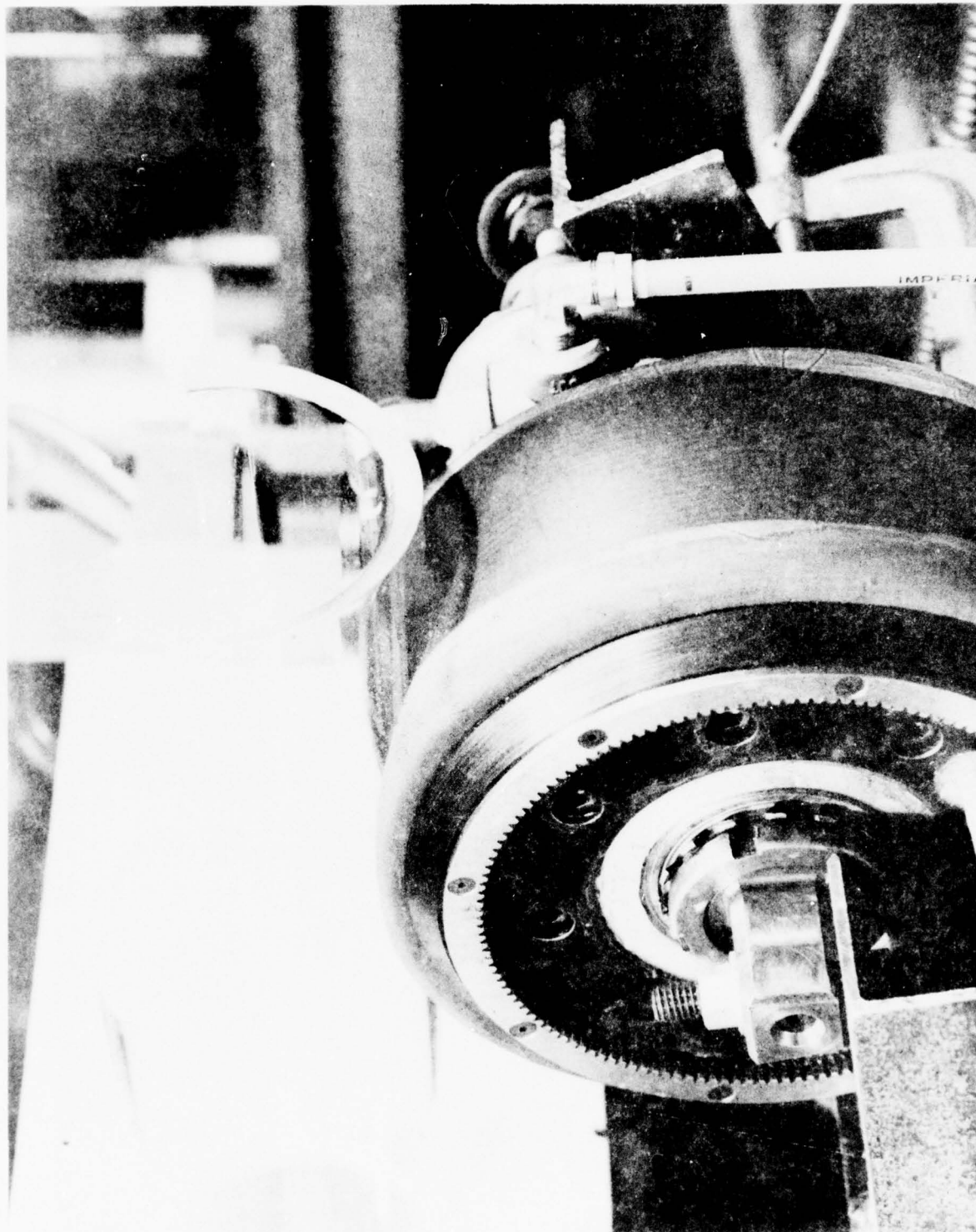

Figure 93. Side View of Roller During Maximum Compression
(10 PSI inflation pressure - 100 lbs. load)

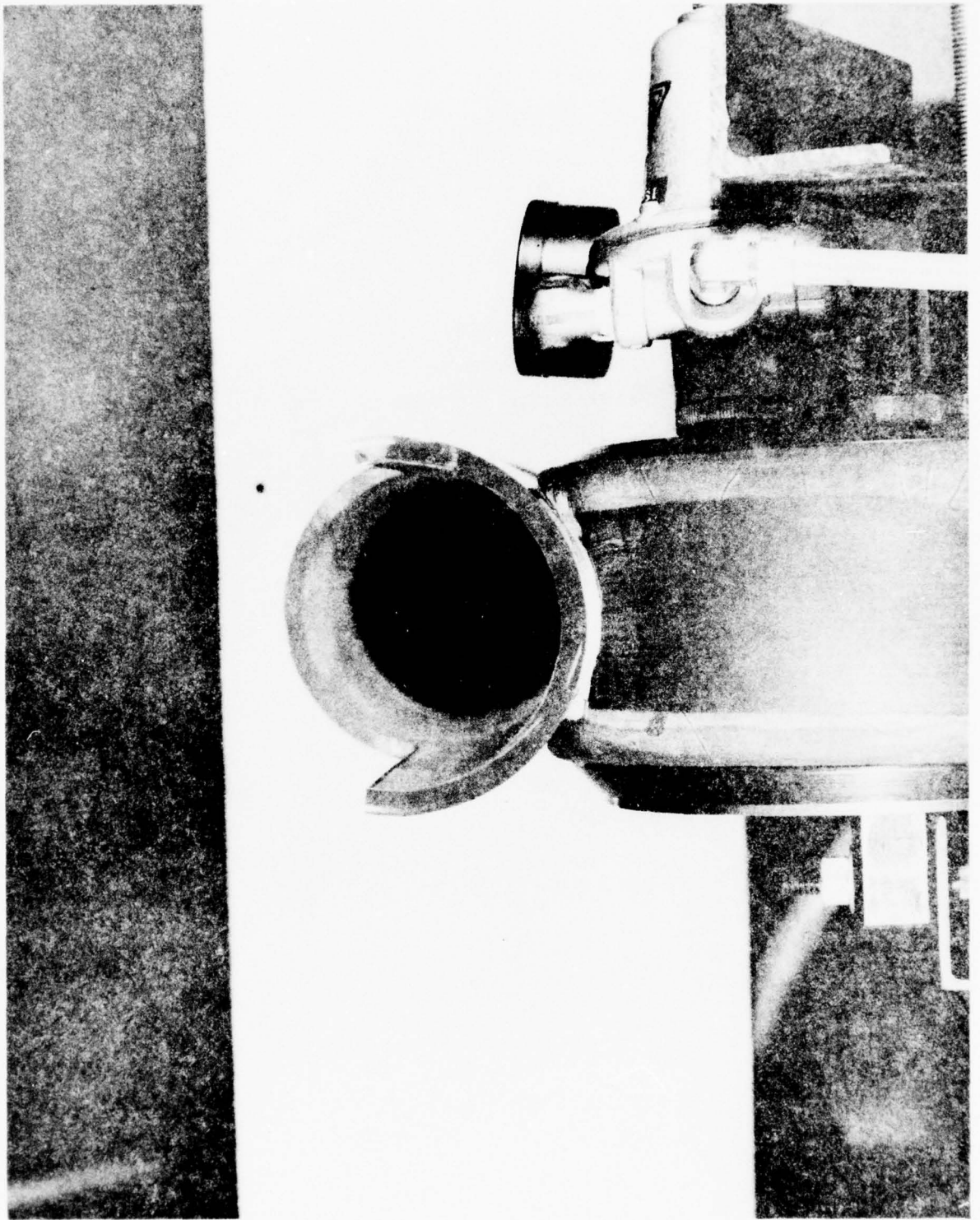

Figure 94. End View of Roller During Maximum Compression
(10 PSI inflation pressure - 100 lbs. load)

APPENDIX III

PERFORMANCE TEST PLAN
U.S. ARMY AUTOMATED
TAPE LAYUP SYSTEM

PERFORMANCE TEST PLAN
U.S. ARMY AUTOMATED
TAPE LAYUP SYSTEM

Rev. Δ 8/21/73

1.0 PURPOSE

The purpose of this plan is to describe a series of functional tests to be performed by the Automated Tape Layup System. These tests have been designed to demonstrate the ability of the system to lay three inch wide tape within specified tolerances during all modes of operation while under full numerical control.

2.0 TEST 1: Flat Pattern Layup (Reference - Figure 95.)

Program the machine to perform the functions described in the Table of Absolute Coordinates. The values listed provide a .030 inch gap between adjacent passes of three inch wide tape.

Upon completion of the pattern, inspect the spacing between adjacent passes for adherence with the specification requirements of 0 to .020 inch gaps with no overlapping allowed.

If an overlapping condition should be found, check the tape width to ascertain that it is no greater than 3.010 inches wide. If it should be found that the tape is running over width, then the condition is beyond the control of the machine and should not be considered as cause for rejection of the pattern. The same case will be true if the tape is running less than 2.990 inches in width and the gap between adjacent passes is running greater than .020 inches.

3.0

TEST 2: Helicopter Blade Wrap (Reference - Figure 96.)

Mount the plaster blade in the Head and Tailstock chucks with the blade's pitch line in a horizontal position.

Mount a spool of preimpregnated fiberglass tape and run the pattern dictated by a numerical-control program tape which has been developed by the line following/digitizing attachment supplied with the machine. The desired path will have been established by a paper tape applied to the blade surface in such a manner as to provide $45^\circ \pm 3^\circ$ helical wraps starting outboard and running into the root of the blade.

Inspect the applied tape for gaps and overlaps between adjacent slit widths of tape as well as adjacent passes and observe the coincidence of centerline of the fiberglass tape to the pre-established theoretical path. If excessive gaps or overlaps occur, check the tape width to determine if out-of-tolerance tape is causing the problem.

As a general rule, the strips of tape formed by the slitting operation should be applied to the blade surface in such a manner as to present the appearance of a full width (3.000 inch) tape having been applied to the surface with only minor gaps discernible to the eye. The exception to this occurs in locations of rapidly changing surface area such as the blade root end. In this type of surface configuration the strips of tape will find some equilibrium line which will create an overlapping condition, either within the three inch width or between adjacent tape lays. Since it is beyond the scope of the machine to adjust to such a condition, "shingling" of some form must be accepted.

4.0 4. TEST 3: Steady Rest Performance Test

Position the Gantry so that it is between the two Steady Rest Assemblies. Mount the Steady Rest Ring sub-assemblies, slide the blade-spar check fixture through them and grip the spar ends with the Head and Tailstock chuck jaws. Adjust the Steady Rests to provide reasonable Gantry movement and proper support for the spar.

Using manual controls, drive the 'D' axis in increments of 20, 40 and 60% of full speed and observe the ability of the Steady Rests to rotate synchronously with the 'D' axis. There should be no visible deformation of the spar due to following error on the part of either Steady Rest. 

Drive the Gantry along the 'X' axis at 720 inches per minute. Observe the longitudinal motion of the Steady Rests to insure that each one maintains adequate clearance between it and the Gantry. 

5.0 TEST 4: Machine High Speed Capability

Program the machine to lay five successive, 8 foot lengths of tape in the X direction and five successive, 6 foot lengths in the Y direction. Tape is to be laid in a flat pattern, directly on or parallel to the machine's primary worksurface. Each pass is to be made in opposition to the previous pass and with a nominal .020 inch gap between them. All passes are to be made at a speed of 720 inches per minute. 

ABSOLUTE COORDINATES
FLAT PATTERN LAYOUT
REF.: FIGURE 1

SHEET 1

PASS NO.	X (INCHES)	Y (INCHES)	Z (INCHES)	A (DEGREES)	C (DEGREES)	D (DEGREES)	SHEAR POSITION (DEGREES)
1	0.000 -120.970	-10.535 -10.535	0.000 0.000	0.00	+180.00	0.00	0.00
2	-120.970 0.000	-7.525 -7.525			0.00		0.00
3	0.000 -120.970	-4.515 -4.515			+180.00		0.00
4	-120.970 0.000	-1.505 -1.505			0.00		0.00
5	0.000 -120.970	+1.505 +1.505			+180.00		0.00
6	-120.970 0.000	+4.515 +4.515			0.00		0.00
7	0.000 -120.970	+7.525 +7.525			+180.00		0.00
8	-120.970 0.000	+10.535 +10.535			0.00		0.00
9	-1.061 -36.826	+13.096 -22.670			-135.00		+45.00
10	-41.083 -3.189	-22.670 +15.224			+45.00		0.00
11	-5.317 -45.340	+17.352 -22.670			-135.00		+45.00
12	-49.597 -7.445	-22.670 +19.480			+45.00		0.00
13	-9.573 -53.854	+21.608 -22.670			-135.00		+45.00
14	-67.116 -111.397	+22.670 -21.608			-135.00		0.00

ABSOLUTE COORDINATES
FLAT PATTERN LAYOUT
REF.: FIGURE 1

SHEET 2

PASS No.	X (INCHES)	Y (INCHES)	Z (INCHES)	A (DEGREES)	C (DEGREES)	D (DEGREES)	SHEAR POSITION (DEGREES)
15	-113.525 -71.373	-19.480 +22.670	0.000 0.000	0.00	+45.00	0.00	+45.00
16	-75.630 -115.653	+22.670 -17.352			-135.00		0.00
17	-117.781 -79.887	-15.224 +22.670			+45.00		+45.00
18	-84.144 -119.909	+22.670 -13.096			-135.00		0.00
19	-119.909 -84.144	+13.096 -22.670			-45.00		-45.00
20	-79.887 -117.781	-22.670 +15.224			+135.00		0.00
21	-115.653 -75.630	+17.352 -22.670			-45.00		-45.00
22	-71.373 -113.525	-22.670 +19.480			+135.00		0.00
23	-111.397 -67.116	+21.608 -22.670			-45.00		-45.00
24	-53.854 -9.573	+22.670 -21.608			-45.00		0.00
25	-7.445 -49.597	-19.480 +22.670			+135.00		-45.00
26	-45.340 -5.317	+22.670 -17.352			-45.00		0.00
27	-3.189 -41.083	-15.224 +22.670			+135.00		-45.00
28	-36.826 -1.061	+22.670 -13.096			-45.00		0.00

ABSOLUTE COORDINATES
 FLAT PATTERN LAYOUT
 REF.: FIGURE 1

SHEET 3

PASS N ^o .	X (INCHES)	Y (INCHES)	Z (INCHES)	A (DEGREES)	C (DEGREES)	D (DEGREES)	SHEAR POSITION (DEGREES)
29	-57.475	-22.670	0.00	0.00	+90.00	0.00	0.00
	-57.475	+22.670	0.00				
30	-60.485	+22.670	↓	↓	-90.00	↓	0.00
	-60.485	-22.670					
31	-63.495	-22.670	↓	↓	+90.00	↓	0.00
	-63.495	+22.670					

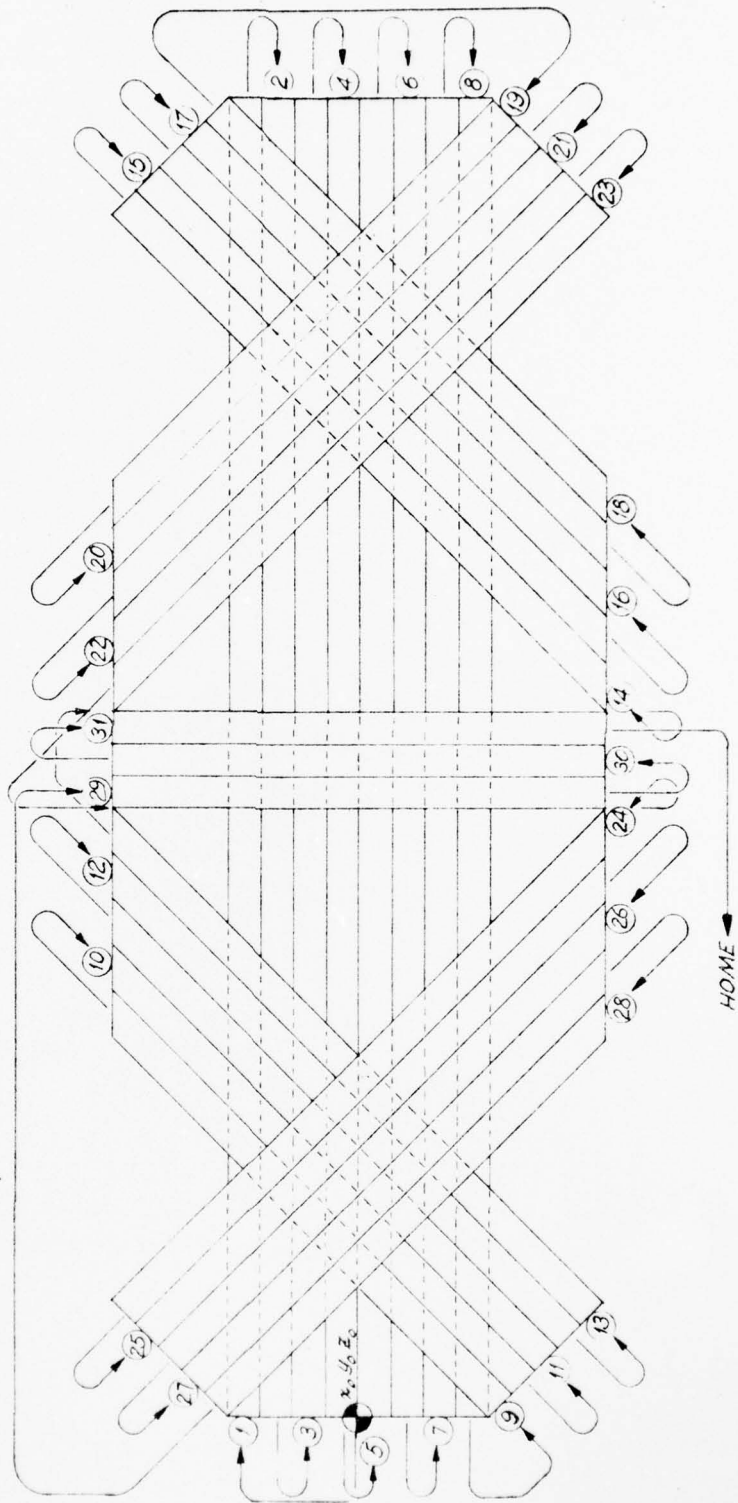
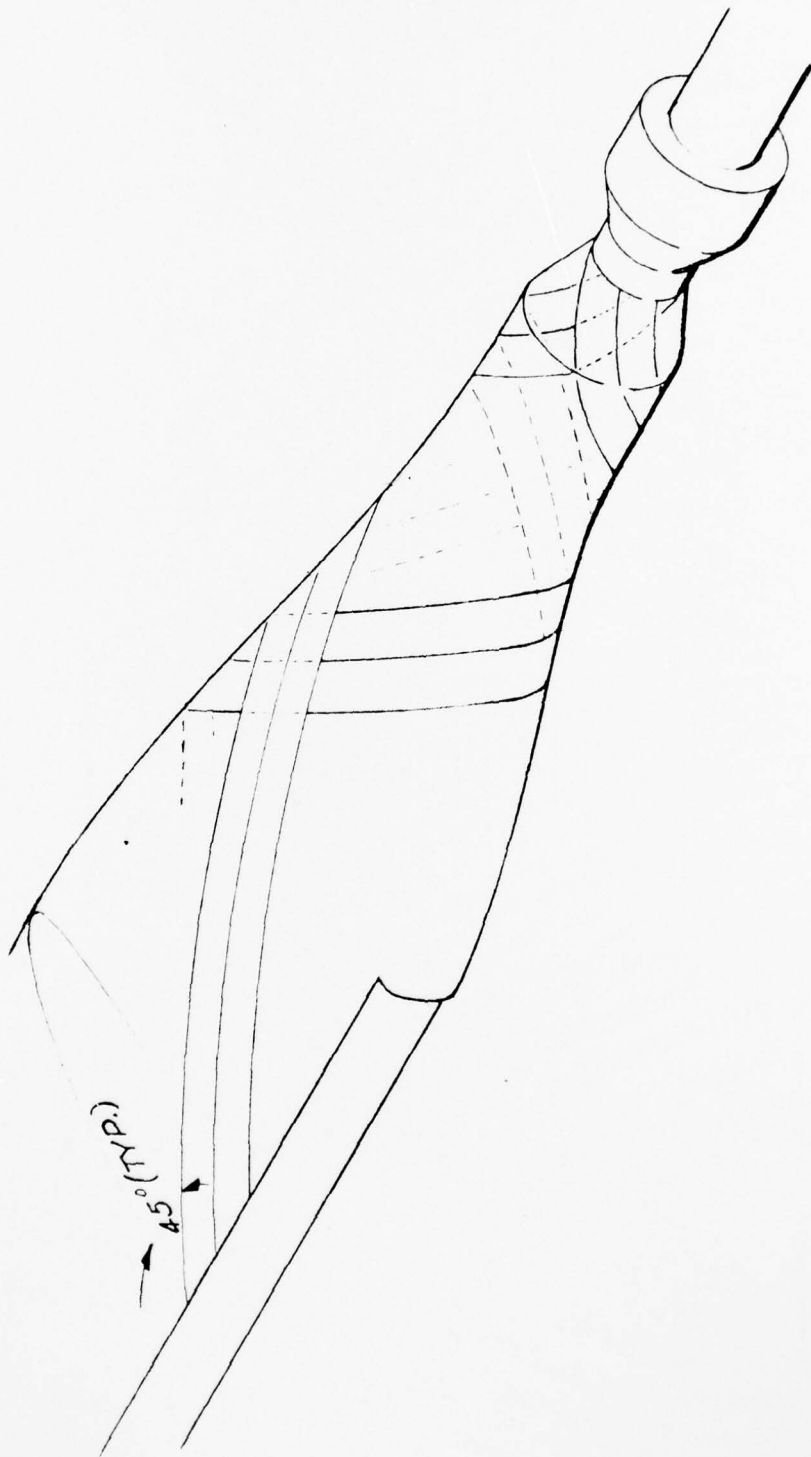

Figure 95. Flat Pattern Layout



APPENDIX IV

COORDINATED TEST PLAN
U.S. ARMY AUTOMATED
TAPE LAYUP SYSTEM

COORDINATED TEST PLAN

U.S. ARMY AUTOMATED

TAPE LAYUP SYSTEM

1.0 ALIGNMENT TESTS

1.1 Work Surface Flatness \triangle \square

1.1.1 Method

Inspect surface at 10.00 inch increments along both X & Y axes for a total of 430 points.

1.1.2 Allowable Deviation

\pm .012/12 inches with a cumulative error no greater than \pm .020 in the total Bed length or width.

1.2 Straightness, Flatness & Parallelism of Bed Ways \triangle \square

1.2.1 Method

Inspect the Master (round) Way optically in the vertical and horizontal planes at 6.00 inch intervals. Inspect the flat Way using a combination of the bridge type inspection fixture and optical equipment for vertical straightness, flatness and parallelism, then switching to the bridge equipped with a dial indicator to inspect horizontal straightness and parallelism.

The bridge is equipped with round way bearings to allow it to ride the Master Way accurately. Adjustable cam followers are fitted at the other end which allow it to straddle the flat Way. As the bridge is rolled the length of the Bed, the end of the bridge directly above the Way will duplicate the vertical movement of the Way.

Positioning a target on the extremity of the bridge and sighting into it with a transit will provide a reference line from which the rise and fall of the Way can be determined. Readings should be taken at 6.00 inch intervals corresponding to the points taken for the Master Way so that the relative position of both Ways to a datum line can be established

Mount a dial indicator on the bridge to bear against the outer edge of the flat Way. Readings should be taken at 6.00 inch intervals corresponding to the points taken for the Master Way so that the runout of the flat Way relative to the Master Way can be defined.

1.2.2 Allowable Deviation

$\pm .002/12$ inches with a cumulative error no greater than .018 in the full Way length.

1.3 Transverse Movement Square with Longitudinal Movement. \triangle \square

1.3.1 Method

A. Establish a line of sight along the X axis by locating a transit so that it focuses on a Gantry mounted target. Locate the base of a 48 inch precision square along the optical reference line. Relocate the transit and establish a second reference along the blade of the square. Mount a target on the machine Cross Slide and establish a zero setting at one end of the Y axis travel. Drive the Slide the length of the Y axis taking readings in 6.00 inch increments.

B. Alternate Method.

Mount a dial indicator on the Gantry base. Lay a 48 inch precision square on its side, on the table, so that the the dial indicator can be used to set the base of the square parallel to the Gantry travel (X axis).

Attach a dial indicator to the machine Cross Slide and bearing against the blade of the square. Drive the Cross Slide the length of the blade, taking readings in 6.00 inch increments.

Reposition the square so that the second half of the Y axis travel can be checked using the same method as outlined.

1.3.2 Allowable Deviation

$\pm .005/12$ inches with a cumulative error no greater than .015 in the total Y axis travel.

1.4 Head Movement Square with Work Mounting Surface \triangle \square

1.4.1 Method

Locate the Cross Slide at the center of the Beam with the Head at its upper limit of travel. Attach a dial indicator to some portion of the Head and position the blade of a 48 inch precision square so that the indicator plunger bears against the blade edge. The base of the square should lay along the X axis. Drive the Head to its lower travel limit taking readings at 6.00 inch intervals. Repeat the procedure with the base of the square along the Y axis.

1.4.2 Allowable Deviation

$\pm .010/12$ inches with a cumulative error no greater than .015 in the full travel.

1.5 Rotation of Head around Pivot Point \triangle

1.5.1 Method

Replace tire assembly with tooling fixture. Mount dial indicator to bear against tooling ball located in the lower end of the fixture. Rotate the Head through 360°.

1.5.2 Allowable Deviation

.006 TIR runout.

1.6 Head Angular Positioning \triangle \square

1.6.1 Method

Insert two .3750 diameter pins into the bushings located in the Roller Yoke and measure their center distance. Set the head at its 0° position and locate an accurate straight edge at least 3.00 inches from each pin. Rotate the Head in 30° increments, measuring the distance from each pin to the straight edge. Mathematically determine the actual angular position of the head.

1.6.2 Allowable Deviation

\pm .02° of arc.

1.7 Positioning Accuracy and Lost Motion in X & Y Axes \triangle \square

1.7.1 Method

Manually command the machine to travel 30 inches in the + X direction. At the end of the travel, locate a dial indicator to bear against the Gantry base. Command the machine to travel 30 inches in the - X direction, then travel 30 inches in the + X direction. Note the indicator reading. Repeat these motions at least three times.

1.7.1 (cont.)

Perform the same task using the Y axis motion.

1.7.2 Allowable Deviation

\pm .005 positioning accuracy in both axes.

\pm .003 repeatability in both axes.

1.8 Longitudinal Movement Straightness \triangle

1.8.1 Method

Position the Gantry at the end of its travel and position the Cross-Slide at the midpoint of its travel. Attach a target on the Guide Shoe of the Tape Head and center a transit to it and parallel to the Master Way.

Drive the Gantry to the extreme of its travel noting the shift of the target center in 12.00 inch increments.

1.8.2 Allowable Deviation

\pm .002/12 inches, \pm .009 maximum.

1.9 Mirror Image Function \square

1.9.1 Method

Replace the Placement Roller with the tooling fixture containing a ball point pen. Tape a 3 foot square sheet of paper to the table and locate the ball of the pen in contact with the paper so that the ball is located at the center of the paper.

1.9.1 (cont.)

Instruct the machine to move 15.000 (-X), and 15.000 (+Y). Return to center and flip the Y axis reverse switch. Repeat the travel instructions and return to zero. Flip the X axis reverse switch, repeat the travel instructions and return to zero. Flip the Y axis to its normal position, repeat the travel instructions and return to zero.

The resulting pattern should be checked to insure that each line drawn is 90° away from the adjacent lines.

1.9.2 Allowable Deviation

Not applicable.

1.10 X & Y Axes Reliability Test

1.10.1 Method

Program 10 separately interpolated trips of the Head between a start point located within a 12 inch square at one corner of the Table and an end point located within a 12 inch square diagonally opposite the first square, at the other end of the Table.

AD-A037 447

GOLDSWORTHY ENGINEERING INC TORRANCE CALIF
U.S. ARMY AUTOMATED TAPE LAYUP SYSTEM 'ATLAS'. (U)
DEC 74 D S STEWART

F/G 13/8

UNCLASSIFIED

DRSAV-76-37

DAAJ01-72-C-0610
NL

4 OF 4
AD
A037447



END
DATE
FILMED
4-77

1.10.1 (cont.)

Mount the tooling ball fixture in place of the roller and adjust two dial indicators to read zero at the starting point. The indicators should be attached to heavy angle plates and located so as to read the X & Y coordinates of the ball position. Locate two indicators in the same manner at the end point.

1.10.2 Allowable Deviation

$\pm .003$ in X direction and $\pm .003$ in Y direction.

1.11 A Axis Positioning Accuracy

1.11.1 Method

Locate and clamp a 1.000 diameter by 18.000 long ground and polished bar into the Roller Axle retaining notches in the lower end of the Yoke.

Position a ground flat bar (24 to 30 inches long) approximately 12 inches below the round bar. Mount a dial indicator on the round bar and adjust it to bear against the upper surface of the flat bar. Run the machine back and forth along the Y axis, adjusting the level of the flat bar to read zero on the indicator.

1.11.1 (cont.)

Once the flat bar is level, rotate the A axis in $\pm 15^\circ$ increments taking readings with a height gage at the extreme ends of the round bar. Subtract the shorter distance from the larger and compare the results with the tabular value.

A Axis Position	Height Reading
15°	4.6588
30°	9.0000
45°	12.7280

1.11.2 Allowable Deviation

$\pm .150$ @ 15° , $\pm .130$ # 30° , $\pm .110$ @ 45°

1.12 D Axis Positioning Accuracy

1.12.1 Method

Fabricate a "T" shaped gage bar by taking a 2 inch diameter bar approximately 9 inches long and accurately locating a 1.000 diameter hole transversely through the center approximately 2 inches from one end.

1.12.1 (cont.)

The hole should provide a slip fit for an 18 inch long, 1.000 inch diameter bar. Provide a tapped hole in the end of the 2 inch bar for a set screw to lock the 1 inch bar. Insert the 1 inch bar into the 2 inch bar, accurately center it and lock it in position with the set screw.

Insert the end of the 2 inch bar into the chuck so that approximately 0.5 inches clearance exists between the end of the chuck jaws and 1 inch diameter bar. Position a ground flat bar, 24 to 30 inches long, approximately 12 inches below the round bar. Level the flat bar optically and rotate the chuck until the round bar is parallel to the flat bar within .001 inches.

Rotate the D axis through $\pm 45^\circ$ in 15° increments taking height readings from the flat bar to extreme ends of the 18 inch long round bar. Subtract the shorter distance from the longer and compare the result with the tabular value.

D Axis Position	Height Reading
15°	4.6588
30°	9.0000
45°	12.7280

1.12.2 Allowable Deviation

$\pm .150 @ 15^\circ$, $\pm .130 @ 30^\circ$, $\pm .110 @ 45^\circ$.

1.13 Machine Reliability Test

1.13.1 Method

Program a complete machine cycle consisting of the following actions:

1. Machine goes to start position
($X_0 Y_0 Z_0 C_0 A_0 D_0$)
2. Machine proceeds with pattern 1
($X_a Y_0 Z_a C_0 A_0 D_0$)
3. Machine proceeds with pattern 2
($X_a Y_b Z_b C_{90} A_0 D_0$)
4. Machine proceeds with pattern 3
($X_c Y_b Z_b C_0 A_{45} D_{45}$)
5. Machine proceeds with pattern 4
($X_c Y_0 Z_a C_{270} A_0 D_0$)
6. Machine proceeds with pattern 5
($X_0 Y_0 Z_0 C_{180} A_0 D_0$)

Repeat patterns for at least four hours.

1.13.2 Allowable Deviation

None

2.0 PERFORMANCE TESTS

2.1 Shearing Angle \triangle \square

2.1.1 Method

Mount a roll of fiberglass tape on the Payoff Reel and string it through the system until the free end has passed through the Guide rolls located beneath the shear. Rotate the Shear to the zero angular position and make a cut.

Pull the tape down approximately 6 inches, rotate the Shear to the $+15^\circ$ angle and make a cut.

Pull the tape down another 6 inches, rotate the Shear to the $+30^\circ$ position and make a cut.

Repeat the procedure at $+45^\circ$ and again at -15° , -30° , -45° . Following the final cut, remove the tape from the machine and lay it, paper liner down, on a flat surface. Measure the angles cut with an accurate protractor using the tape edge as the reference edge.

2.1.2 Allowable Deviation

$\pm 0.5^\circ$

2.2 Sheared Length

2.2.1 Method

String fiberglass tape through the system until the end of the tape is centered beneath the Placement Roll. Drive the Tape Head down contacting the working surface. Continue downward until the Placement Roll has been displaced 0.5 inches with the air pressure regulator set at 16 PSIG. (equivalent to a compaction load of 50 pounds).

Rotate the Shear to the zero angle setting and cut the tape. Instruct the machine to travel 18.000 inches, stop and shear, then travel an additional 30.000 inches. Measure the distance between the two cut lines.

2.2.2 Allowable Deviation

$\pm .060$ inches

2.3 Gap Control

2.3.1 Method

Program the machine to lay four - 48.00 inch long

passes along the X-axis, indexing in the Y direction 3.010 inches between each pass. Subsequent passes are to be made in the opposite direction to the previous one, i.e., first pass in the -X direction, second pass in the +X direction and so forth.

Instruct the machine to move to a location beyond the aforementioned laydown pattern and make four passes in the Y direction, each one 48.000 inches in length. Index in the X direction 3.010 inches between each pass. Subsequent passes are to be made in the opposite direction to the previous one.

Measure the gap between adjacent tape strips at 6 inch intervals.

2.3.2 Allowable Deviation

0 to .020 inches with no overlapping.

The symbols: Δ & \square indicate those tests which conform generally to either the AIAA Specification NAS 990 (Δ) or the Air Force Materials Laboratory Specification AFML-TR-71-71 (\square). In certain instances both specifications were used as a basis for a given test.

TEST RECORD

GOLDSWORTHY ENGINEERING, INC.

6 AXIS AUTOMATED TAPE LAYUP SYSTEM

MODEL NUMBER. _____

SERIAL NUMBER. _____

REFERENCE: COORDINATED TEST PLAN FOR
U.S. ARMY AUTOMATED TAPE LAYUP SYSTEM

TEST NO.

DESCRIPTION

ALLOWABLE TOLERANCE

INITIAL CHECK
(AT G.E.I.)

FINAL CHECK
(AT B/V)

TEST NO.	DESCRIPTION	ALLOWABLE TOLERANCE	INITIAL CHECK (AT G.E.I.)	FINAL CHECK (AT B/V)
1.1	WORK SURFACE FLATNESS	±.012/12 IN. ±.020 IN. MAX.		
1.2	BED WAYS - STRAIGHTNESS, FLATNESS PARALLELISM	.002/12 IN. .018 IN. MAX.		
1.3	Y AXIS SQUARENESS WITH X AXIS	.005/12 IN. .015 IN. MAX.		
1.4	Z AXIS SQUARENESS WITH WORK SURFACE	.010/12 IN. .015 IN. MAX.		
1.5	C AXIS ROTATION	.006 IN. T.I.R.		
1.6	HEAD ANGULAR POSITIONING	±.02° of A/C		
1.7	POSITIONING ACCURACY & LOST MOTION IN X & Y AXES	±.005 POSITIONING ±.003 REPEATABILITY		

FINAL CHECK
(AT B/V)

INITIAL CHECK
(AT G.E.I.)

ALLOWABLE
TOLERANCE

DESCRIPTION

TEST
NO.

TEST NO.	DESCRIPTION	ALLOWABLE TOLERANCE	INITIAL CHECK (AT G.E.I.)	FINAL CHECK (AT B/V)
1.8	LONGITUDINAL MOVEMENT STRAIGHTNESS	.002/12 IN. ±.009 IN. MAX.		
1.9	MIRROR IMAGE FUNCTION	N.A.		
1.10	X & Y AXES RELIABILITY TEST	±.003 IN. X AXIS ±.003 IN. Y AXIS		
1.11	A AXIS POSITIONING	±.150 IN. @ 15° ±.130 IN. @ 30° ±.110 IN. @ 45°		
1.12	D AXIS POSITIONING	±.150 IN. @ 15° ±.130 IN. @ 30° ±.110 IN. @ 45°		
1.13	MACHINE RELIABILITY	4 HR. TEST RUN		
2.1	SHEARING ANGLE	± 0.5°		
2.2	SHEARED LENGTH	± .060 IN.		

TEST NO.

DESCRIPTION

ALLOWABLE TOLERANCE

INITIAL CHECK (AT G.E.I.)

FINAL CHECK (AT B/V)

TEST NO.	DESCRIPTION	ALLOWABLE TOLERANCE	INITIAL CHECK (AT G.E.I.)	FINAL CHECK (AT B/V)
2.3	GAP CONTROL	0 - .020 IN. NO OVERLAP		