

ADA 037901

REPORT NO. NADC-76235-30

12
Hutchins



FATIGUE INVESTIGATION OF THE C-2A NOSE LANDING GEAR

H. D. Lystad
Air Vehicle Technology Department
NAVAL AIR DEVELOPMENT CENTER
Warminster, Pennsylvania 18974

14 OCTOBER 1976

DDC
RECEIVED
APR 8 1977
A

FINAL REPORT
AIRTASK NO. A510-5103/001-4/4510-000-002
Work Unit No. A53022A069

APPROVED FOR PUBLIC RELEASE; DISTRIBUTION UNLIMITED

DDC FILE COPY

Prepared for
NAVAL AIR SYSTEMS COMMAND
Department of the Navy
Washington, D.C. 20361

NADC-76235-30

NOTICES

REPORT NUMBERING SYSTEM - The numbering of technical project reports issued by the Naval Air Development Center is arranged for specific identification purposes. Each number consists of the Center acronym, the calendar year in which the number was assigned, the sequence number of the report within the specific calendar year, and the official 2-digit correspondence code of the Command Office or the Functional Department responsible for the report. For example: Report No. NADC-76015-40 indicates the fifteenth Center report for the year 1976, and prepared by the Crew Systems Department. The numerical codes are as follows:

CODE	OFFICE OR DEPARTMENT
00	Commander, Naval Air Development Center
01	Technical Director, Naval Air Development Center
02	Program and Financial Management Department
09	Technology Management Office
10	Naval Air Facility, Warminster
20	Aero Electronic Technology Department
30	Air Vehicle Technology Department
40	Crew Systems Department
50	Systems Department
60	Naval Navigation Laboratory
81	Technical Support Department
85	Computer Department

PRODUCT ENDORSEMENT - The discussion or instructions concerning commercial products herein do not constitute an endorsement by the Government nor do they convey or imply the license or right to use such products.

APPROVED BY:

Paul M. Sturm
PAUL M. STURM
Commander, USN
Deputy Director, AVTD

DATE: 14 Oct 1976

UNCLASSIFIED

SECURITY CLASSIFICATION OF THIS PAGE (When Data Entered)

REPORT DOCUMENTATION PAGE		READ INSTRUCTIONS BEFORE COMPLETING FORM
1. REPORT NUMBER NADC-76235-30	2. GOVT ACCESSION NO.	3. RECIPIENT'S CATALOG NUMBER
4. TITLE (and Subtitle) FATIGUE INVESTIGATION OF THE C-2A NOSE LANDING GEAR		5. TYPE OF REPORT & PERIOD COVERED FINAL REPORT
7. AUTHOR(s) H. D. LYSTAD		6. PERFORMING ORG. REPORT NUMBER
9. PERFORMING ORGANIZATION NAME AND ADDRESS Air Vehicle Technology Department Naval Air Development Center Warminster, Pa. 18974		8. CONTRACT OR GRANT NUMBER(s)
11. CONTROLLING OFFICE NAME AND ADDRESS Naval Air Systems Command Department of the Navy Washington, D. C. 20361		10. PROGRAM ELEMENT, PROJECT, TASK AREA & WORK UNIT NUMBERS AIRTASK A510-5103/001-4/ 4510-000-002, WORK UNIT A530222A-69
14. MONITORING AGENCY NAME & ADDRESS (if different from Controlling Office)		12. REPORT DATE 14 Oct 1976
		13. NUMBER OF PAGES 36p.
		15. SECURITY CLASS. (of this report) UNCLASSIFIED
		15a. DECLASSIFICATION/DOWNGRADING SCHEDULE
16. DISTRIBUTION STATEMENT (of this Report) Approved for Public Release; Distribution Unlimited		
17. DISTRIBUTION STATEMENT (of the abstract entered in Block 20, if different from Report)		
18. SUPPLEMENTARY NOTES		
19. KEY WORDS (Continue on reverse side if necessary and identify by block number) Fatigue (Materials) Fatigue Tests Service Life		
20. ABSTRACT (Continue on reverse side if necessary and identify by block number) A laboratory fatigue investigation was performed on a C-2A nose landing gear to determine whether the authorized limit of 900 catapult launches could be extended. During the application of test cycle 1,260, the shock strut outer cylinder failed. Using a test scatter factor of two, this is equivalent to 630 service catapult launches. Combined with the estimated 310 in-service catapult launches of the test specimen, this indicates no allowable increase in the C-2A nose landing gear service life.		

DD FORM 1 JAN 73 1473

EDITION OF 1 NOV 65 IS OBSOLETE
S/N 0102-014-6601

407 209 UNCLASSIFIED

SECURITY CLASSIFICATION OF THIS PAGE (When Data Entered)

SECURITY CLASSIFICATION OF THIS PAGE(When Data Entered)

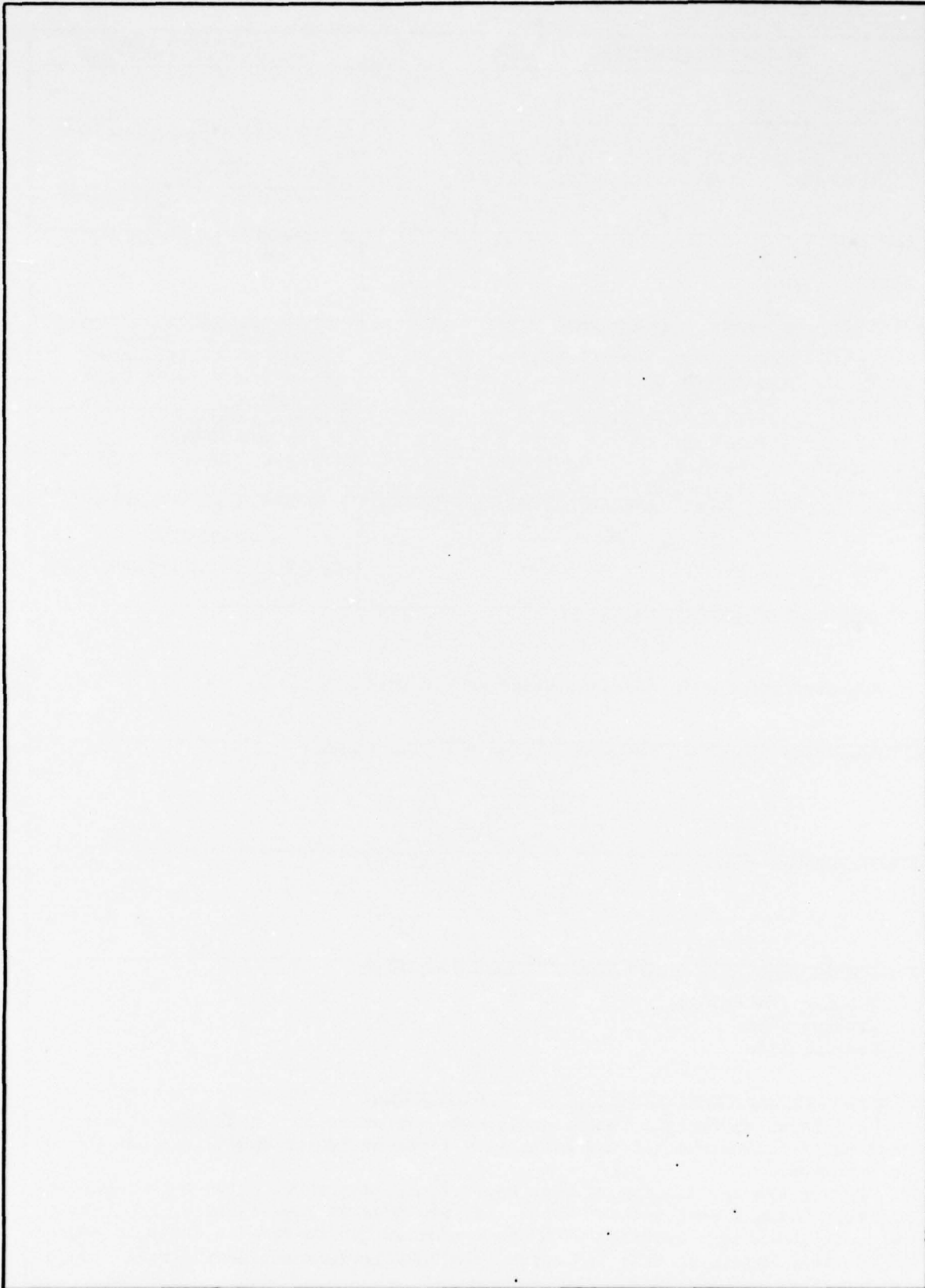

SECURITY CLASSIFICATION OF THIS PAGE(When Data Entered)

S U M M A R Y

A laboratory fatigue investigation was performed on a C-2A nose landing gear to determine whether the authorized limit of 900 catapult launches could be extended.

During the application of test cycle 1,260, the shock strut outer cylinder failed. Using a test scatter factor of two, this is equivalent to 630 service catapult launches. Combined with the estimated 310 in-service catapult launches of the test specimen, this indicates no allowable increase in the C-2A nose landing gear service life.

T A B L E O F C O N T E N T S

<u>Title</u>	<u>Page No.</u>
SUMMARY	1
LIST OF FIGURES	3
LIST OF TABLES	3
INTRODUCTION	4
DESCRIPTION OF TEST SPECIMENS	4
TEST PROGRAM	5
TOTAL LOADING SEQUENCE	5
LANDING SEQUENCE	5
CATAPULT LAUNCH SEQUENCE	6
TEST METHOD	7
TEST RESULTS	11
DISCUSSION	11
CONCLUSIONS	17
RECOMMENDATIONS	17
REFERENCES	18
APPENDIX A - TEST DATA FOR THE C-2A NOSE LANDING GEAR FATIGUE INVESTIGATION	A-1

L I S T O F F I G U R E S

<u>Figure No.</u>	<u>Title</u>	<u>Page No.</u>
1	Typical Loading Cycle	8
2	Test Set-Up - View from Right Side	9
3	Test Set-Up - View Looking Aft	10
4	Outer Cylinder Failure - View Looking Aft	12
5	Outer Cylinder Failure - View Looking Forward	13
6	Outer Cylinder Failure - Side View	14
7	Outer Cylinder Failure - Lower Fracture Surface	15
8	Close-up of Failure Initiation Surface	16

L I S T O F T A B L E S

<u>Table No.</u>	<u>Title</u>	<u>Page No.</u>
I	Test Specimens	4
II	Landing Spectrum	6

I N T R O D U C T I O N

The C-2A nose landing gear (NLG) assembly was fatigue tested to the catapult launch condition several years ago by the Grumman Aerospace Corporation (GAC), as reported in reference (1). The nose gear shock strut outer cylinder failed after the application of 1,807 test launches, which imposed a usable fatigue life of 900 catapult launches on the C-2A NLG. This fatigue life is now insufficient to satisfy the current projected operational requirements of the C-2A airplane.

There has been no major remanufacturing or rework of the C-2A NLG since its acceptance. However, the catapult tow force of 960 820 N (216,000 pounds) used for the original fatigue test has been shown from carrier studies to be 871 850 N (196,000 pounds) mean load with an upper 90 percentile of 938 570 N (211,000 pounds), shown in reference (2). A fatigue investigation of the C-2A NLG was required to determine if this reduction in catapult tow force would be sufficient to increase the service life beyond the long lead time required for procuring NLG replacement components.

D E S C R I P T I O N O F T E S T S P E C I M E N

The test specimen was a C-2A NLG which was removed from service and consisted of the components listed in Table I.

<u>TABLE I</u>	
TEST SPECIMENS	
Item	Part No.
Shock Strut Assembly	Part No. 13648-00
Drag Brace Assembly	Part No. 1364-172
Tow Link	Part No. 123LM40583-3
Tow Link Pin	Part No. 123LM40582

The shock strut assembly consisted of an axle-caster barrel, outer cylinder and inner cylinder. Since none of the above parts are included in a component tracking system, service data, such as total service time, number of landings and number of launches experienced was not available. The number of catapult launches experienced by the test specimen was estimated based on average C-2 usage data as shown in the discussion of this report.

The C-2 is a nose tow type airplane. The nose gear is a retractable, dual wheel assembly, equipped with an inverted metered orifice oleo shock strut. The catapult forces on the NLG tow link are transmitted by the shock strut and drag brace to support fittings attached to the fuselage. The

shock strut support (trunnion) fittings, located at fuselage station (FS) 66.652, provide vertical and lateral stability and also serve as the pivot for gear retraction and extension. Fore and aft stability is provided by the drag brace support fittings, located at FS 130.101. Torsion about the oleo centerline is transmitted through the caster barrel and steering damper into the outer cylinder and finally reacted by the drag brace.

T E S T P R O G R A M

To demonstrate the capability to withstand the effects of repeated catapult launches and establish the service life limit of the C-2A NLG, simulated carrier landings and catapult launches were applied to the test specimen using the loading conditions found in Appendix A.

The locations of the applied loads and reactions, magnitude and direction are shown in Appendix A, Table A-I and Figures A-2 through A-8. Loads were applied in accordance with the test spectrum shown below.

TOTAL LOADING SEQUENCE

- Step 1. Apply NLG actuating cylinder load
- Step 2. Apply landing sequence
- Step 3. Remove NLG actuating cylinder load
- Step 4. Apply NLG actuating cylinder load
- Step 5. Apply catapult launch sequence
- Step 6. Remove NLG actuating cylinder load

The above loading sequence constitutes one carrier landing followed by one carrier catapult launch. Details of the landing sequence (Step 2) and the catapult launch sequence (Step 5) are as follows:

LANDING SEQUENCE

- Step A. Apply the vertical and aft spin-up loads ($Z_{SU} + X_{SU}$).
- Step B. Reduce X_{SU} to zero and apply the forward spring-back load (X_{SB}) as Z_{SU} builds to the vertical spring-back load (Z_{SB}).
- Step C. Reduce X_{SB} to zero and apply the aft second cycle spin-up load (X_{SU2}) as Z_{SB} , which equals the vertical second cycle spin-up load (Z_{SU2}), is held constant.
- Step D. Reduce all loads to zero.

The above sequence of loading constitutes one carrier landing and is applied using the spectrum of sink speeds (V_S) shown in Table II.

TABLE II
LANDING SPECTRUM

V_S m/s (Ft/Sec.)	Occurrences per 500 Carrier Landings	% of Maximum Applied Load		
		$Z_{SU2} = Z_{SB}$	$X_{SU2} = X_{SB}$	$X_{SU} = Z_{SU}$
6.096 (20)	1	100	100	100
5.791 (19)	2	91	98	98
5.486 (18)	4	82	95	95
5.182 (17)	7	73	92	92
4.877 (16)	486	65	90	90

The spectrum of V_S per 500 carrier landings, obtained from reference 3, is truncated at the sink speed of 4.877 m/s (16 fps). All counts of lower sink speed were added to the 4.877 (m/s (16 fps) sink speed. The above spectrum of sink speeds is repeated every 500 landing cycles as follows:

Landings 1 to 486 at $V_S = 4.877$ m/s (16 fps)

Landings 487 to 493 at $V_S = 5.182$ m/s (17 fps)

Landings 494 to 497 at $V_S = 5.486$ m/s (18 fps)

Landings 498 to 499 at $V_S = 5.791$ m/s (19 fps)

Landing 500 at $V_S = 6.096$ m/s (20 fps)

CATAPULT LAUNCH SEQUENCE

Step A. Apply simultaneously the loads of condition 11 D twice.

Step B. Apply simultaneously the loads of condition 11 A once.

Step C. Apply simultaneously the loads of condition 11 C_a once.

The above sequence constitutes one catapult launch cycle. During the application of the loads for conditions 11 D and 11 A the side load is applied first to left, for 100 launches, then to the right for 100 launches. This sequence repeats every 200 launches.

For condition 11 C_a, the loading is varied as follows:

Catapult launch 1 to 9; apply 93% of the maximum tow link and axle loads simultaneously.

Catapult launch 10; apply 100% of the maximum tow link and axle loads simultaneously.

This procedure is repeated every 10 launch cycles. During the application of condition 11C_a, side loads were applied to the tow link at the same percentage of maximum load as the tow load, in the following manner.

Step A. Apply all X and Z loads simultaneously.

Step B. Hold X + Z loads; apply side load once to the left then once to the right.

Step C. Reduce X and Z loads to zero.

A typical loading cycle of one carrier landing followed by one catapult launch is shown in Figure 1.

The loading sequence depicted above is repeated until specimen failure occurred.

T E S T M E T H O D

The test specimen was mounted in an inverted position, in a loading frame. Test loads were reacted at the shock strut upper trunnions and the drag brace trunnions. Steel fixtures were fabricated to simulate the C-2 airplane fuselage fittings for the shock strut and drag brace supports. Adapter fittings were fabricated to apply loads to the test specimen at the catapult tow link, holdback lugs and wheel axles. The metering pin was removed from the oleo shock strut and replaced with a plug. The shock strut was then filled with hydraulic fluid to fix the gear in the fully extended static position throughout the test.

Test loads were applied to the specimen with hydraulic actuators which were part of an electro-hydraulic, servo-controlled closed loop loading system. Independent control of each actuator was provided by individual servo-valves and servo-controllers. Load direction and phase relationships for the actuators were provided by a multichannel programmer.

Loads were monitored on chart recorders and a multichannel bar graph video display, all of which provided overload protection. Additional and independent overload protection was provided by error detectors on each servo-controller and stroke limit switches on each actuator. Triggering an overload system would immediately dump hydraulic pressure at each actuator and at the hydraulic power supply.

A full NDI (Non Destructive Inspection) of each test specimen was performed prior to the test. Inspections of critical areas were performed throughout the test. Nose gear maintenance and lubrication was also performed at scheduled intervals throughout the test.

Figures 2 and 3 show the final test set-up.

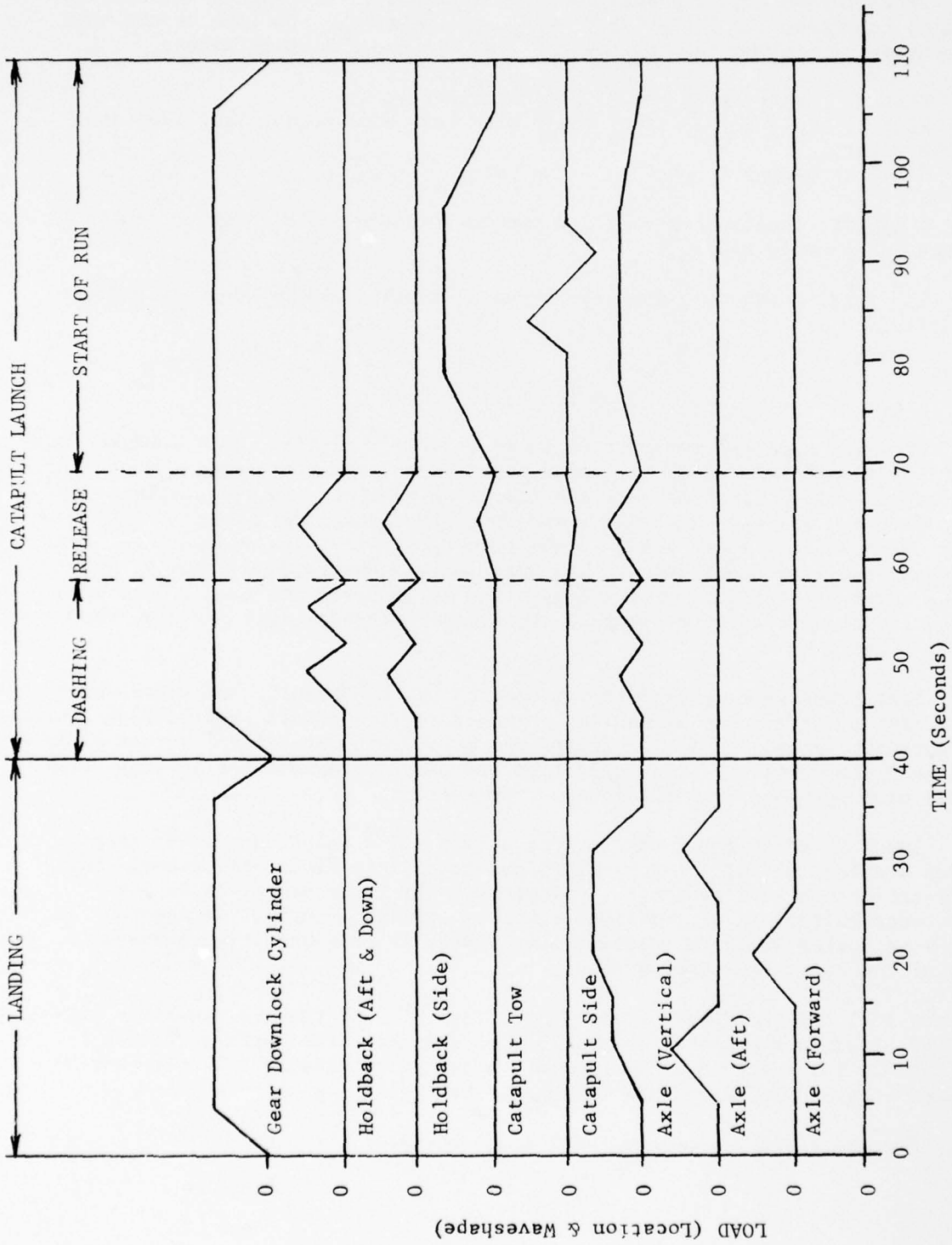

Figure 1. Typical Loading Cycle

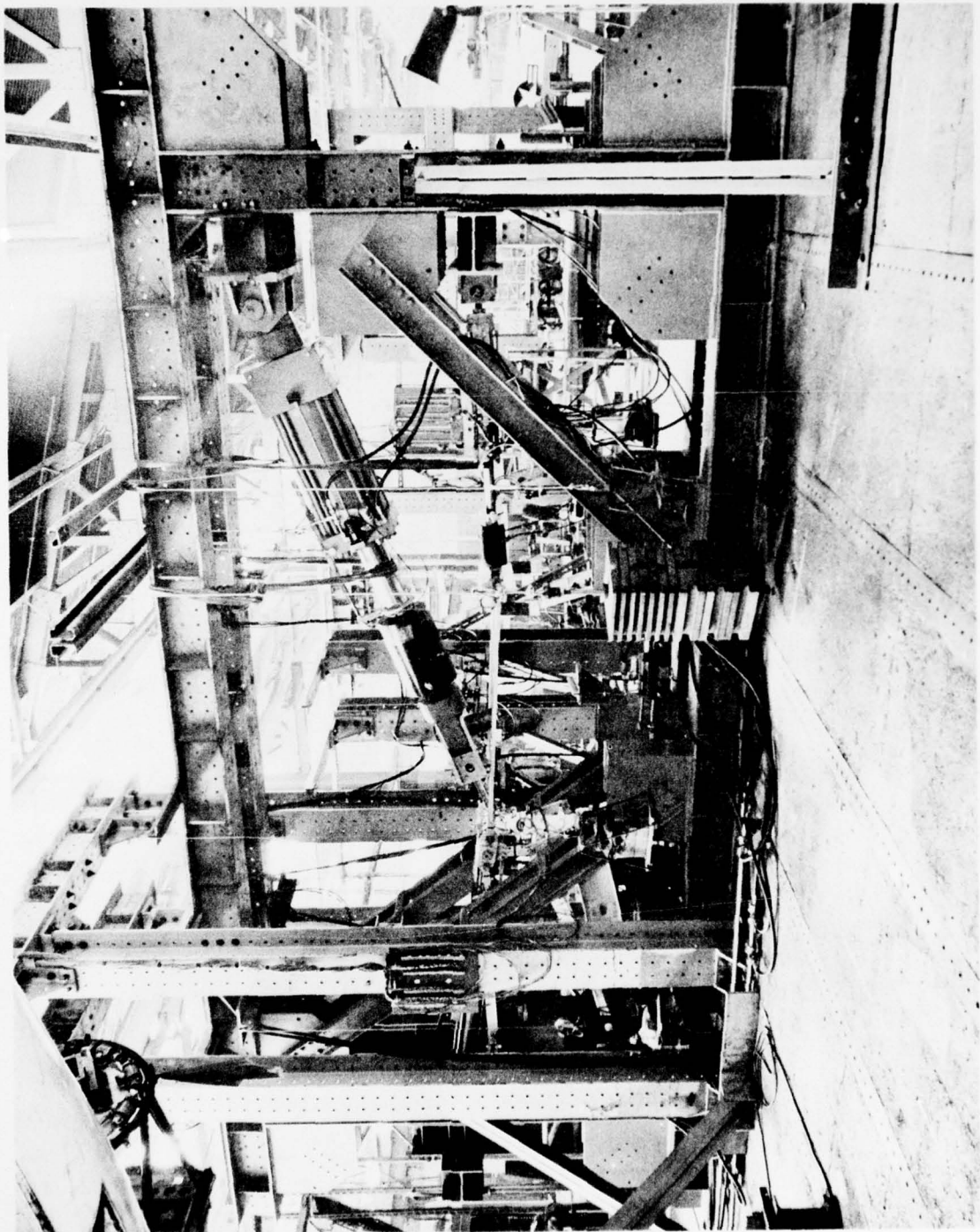

Figure 2. Test Set-Up - View from Right Side

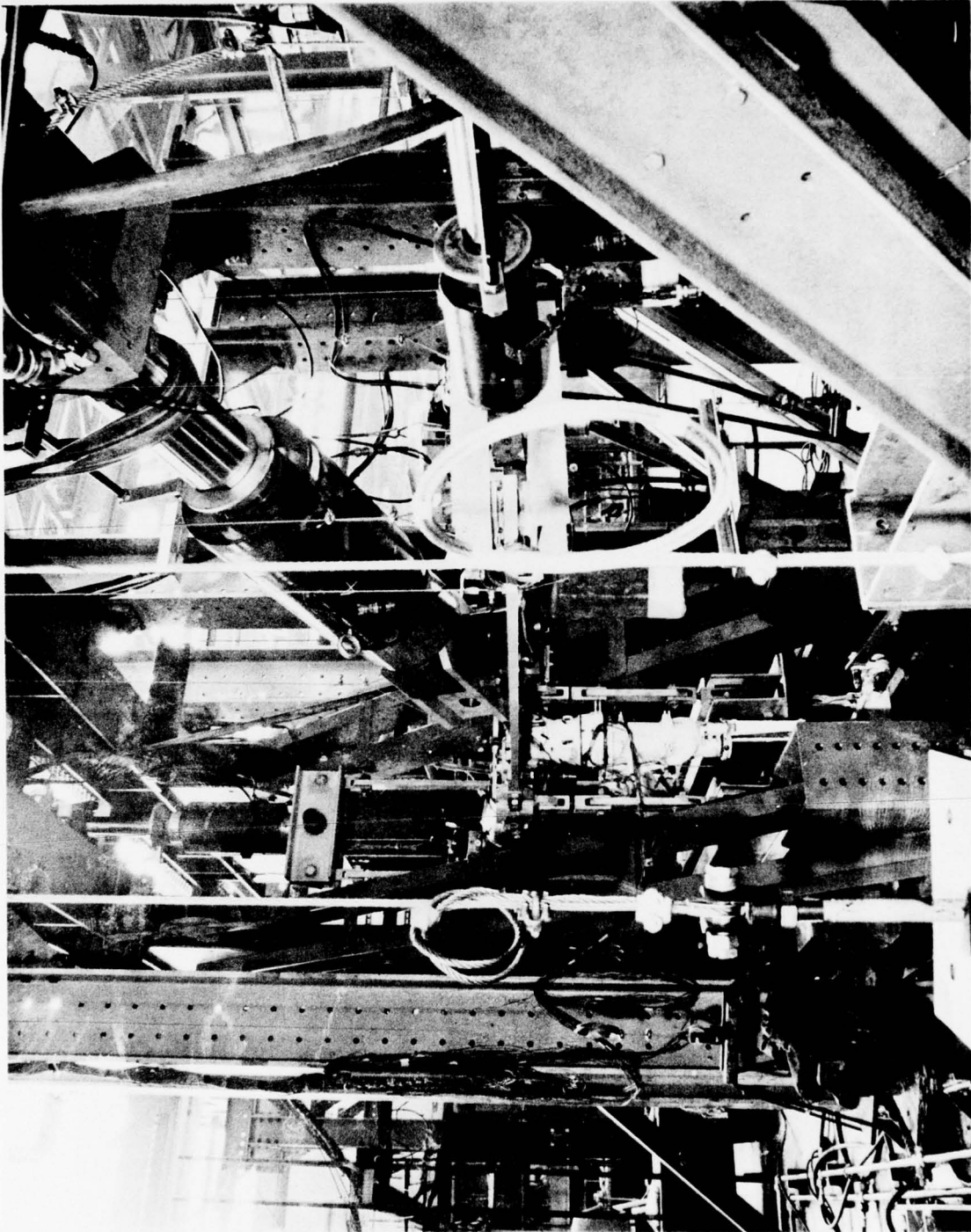

Figure 3. Test Set-up - View Looking Aft

T E S T R E S U L T S

During the application of test cycle 1,260 the shock strut outer cylinder failed. The cylinder was completely severed as shown in Figures 4 and 5. The test specimen was removed from the set-up and disassembled for examination of the fracture surfaces. Figures 6 and 7 show the failed outer cylinder and the lower fracture surface after disassembly of the test specimen.

Visual examination of the fracture surfaces revealed evidence of a two stage failure, starting at the aft side of the outer diameter of the cylinder. A semi-circular ring, approximately .0305 m (1.2 inches) long and .0038 m (0.15 inches) deep, hereby designated area A, is the first stage, where the failure originated and is shown in Figure 8. The second stage, hereby designated area B, is the remaining section of the cylinder and is also shown in Figure 8. A section of the outer cylinder encompassing all of area A and a portion of area B was removed from the specimen and sent to the Aero Materials Laboratory (AML) of the NAVAIRDEVCEEN for metallurgical analysis.

A scanning electron microscope examination of area A of the fracture surface showed that a mixture of intergranular fracture, fatigue and local ductile fracture was present, but could not be certain as to the exact mode of failure. However, the following explanation has been offered by the AML: An extensive literature survey revealed several cases of fractures identical to the test fracture. These failures were attributed to hydrogen embrittlement and/or stress corrosion. The general belief is that these two modes of failure are identical. The failed NLG cylinder was manufactured from air melted 4330 steel which is more susceptible to stress corrosion crack growth than vacuum melted steel. The reason for this is not clear but is likely to be related to the hydrogen content. The evidence indicates that a stress corrosion mechanism initiated the failure and that as the stress intensity increased with crack growth a fatigue mechanism became predominant. This fatigue mechanism continued as the crack propagated across area A. After 1,260 test cycles, area A became critically sized and the remaining section (area B) failed due to shear overload.

D I S C U S S I O N

The test specimen was removed from service and had an unknown number of catapult launches prior to test. By examination of the Navy Weapons - Dahlgren, Virginia Naval aircraft usage tape data, it was determined that C-2A aircraft, as of September 1974, (when the test specimen was made available to the NAVAIRDEVCEEN) experienced an average of 365 arrestments per airplane, since its acceptance. It was also determined that from August 1970, (when the compilation of catapult launch data was initiated) until September 1974 the C-2A airplane experienced 0.85 catapults per arrestment. Therefore, the estimated number of catapult launches for the test specimen was determined as being:

$$365 \text{ arrestments} \times 0.85 \text{ catapult launches/arrestment} = 310 \text{ catapult launches}$$

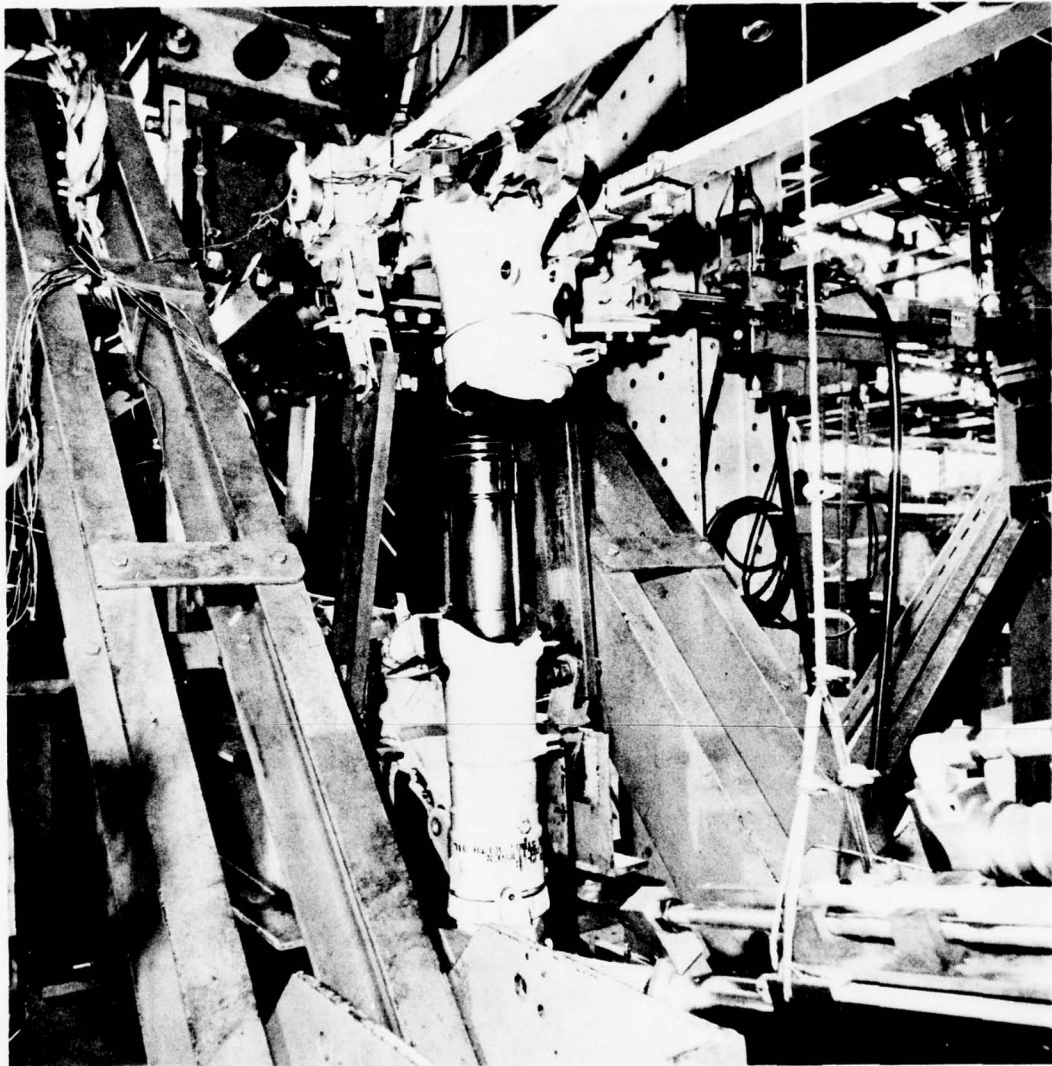

Figure 4. Outer Cylinder Failure - View Looking Aft

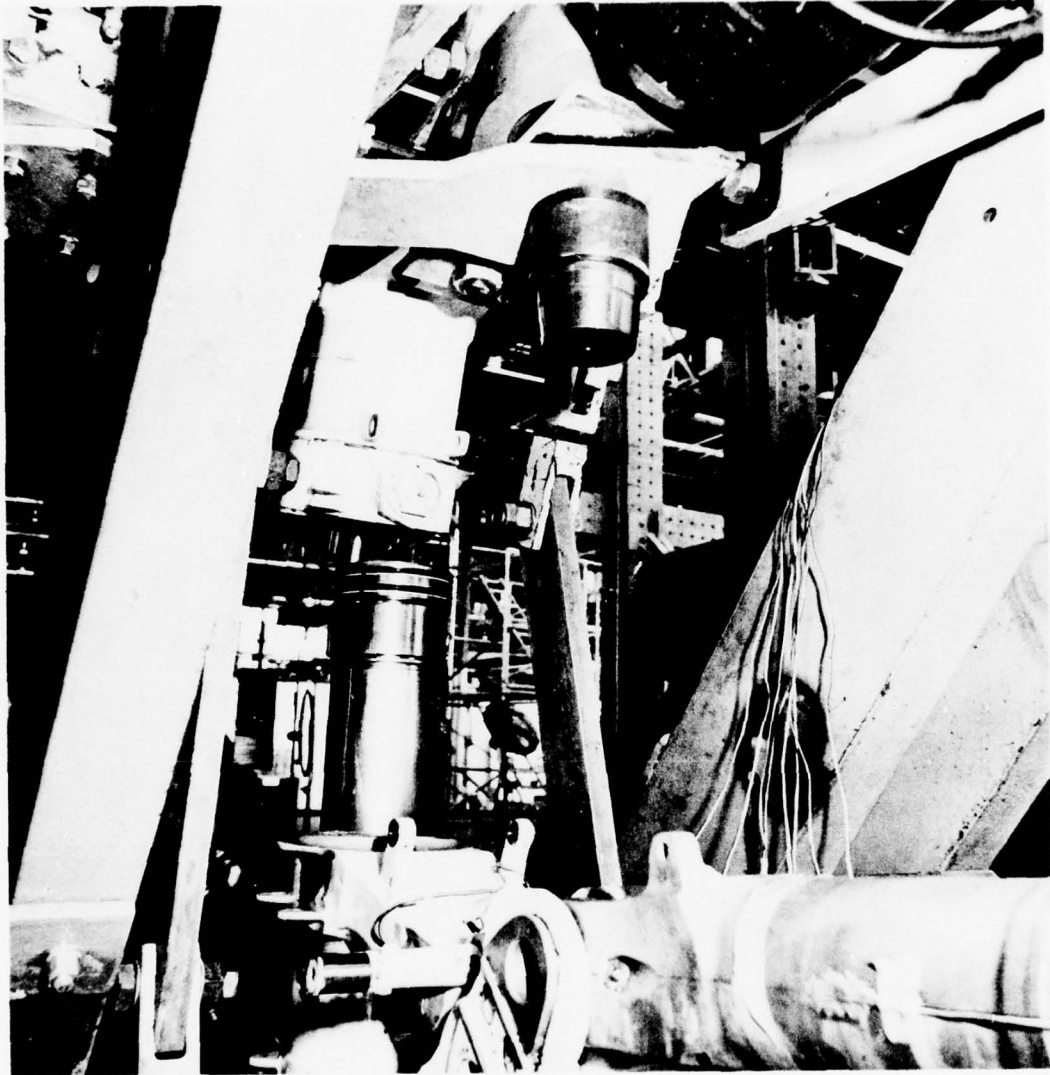

Figure 5. Outer Cylinder Failure - View Looking Forward

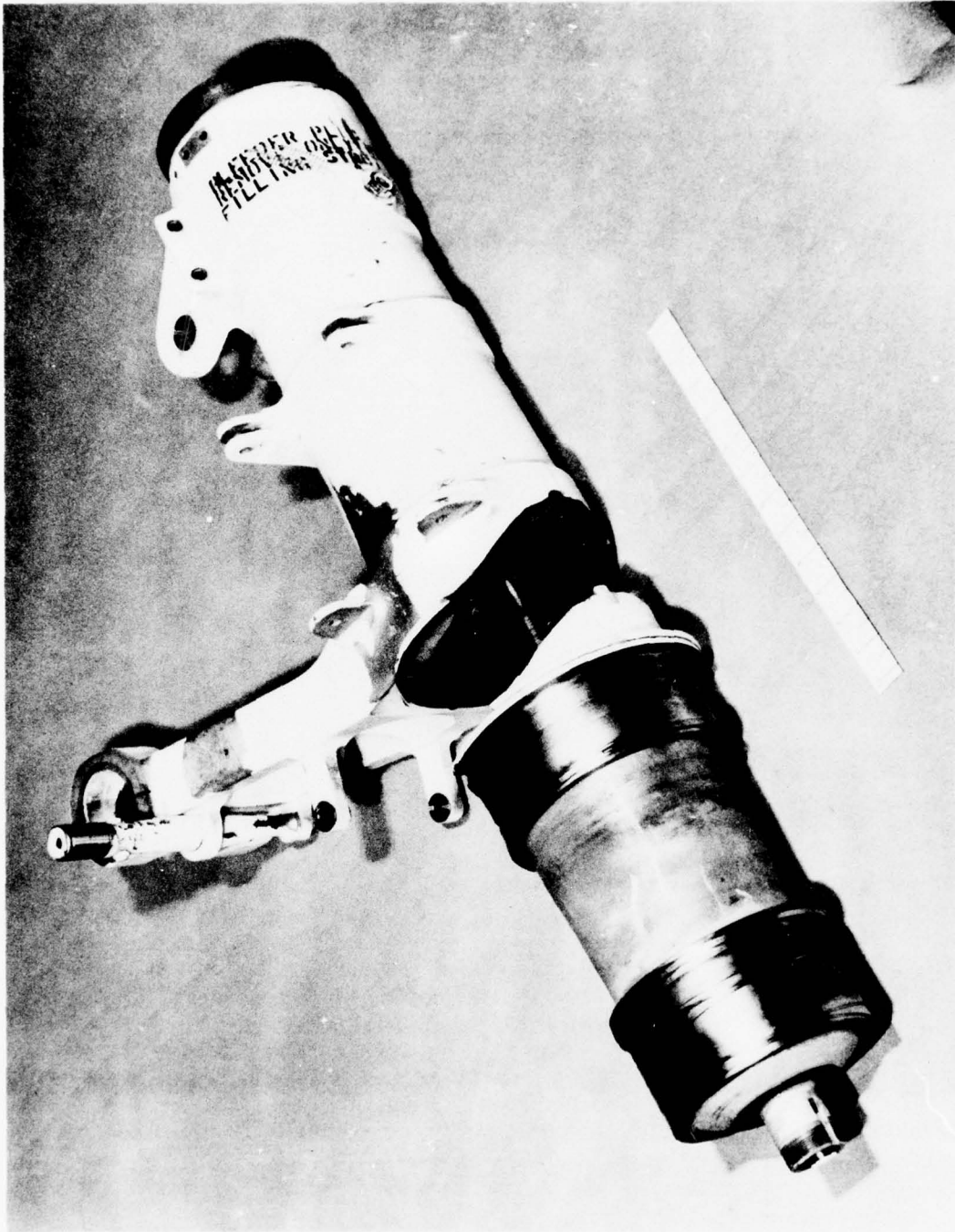

Figure 6. Outer Cylinder Failure - Side View

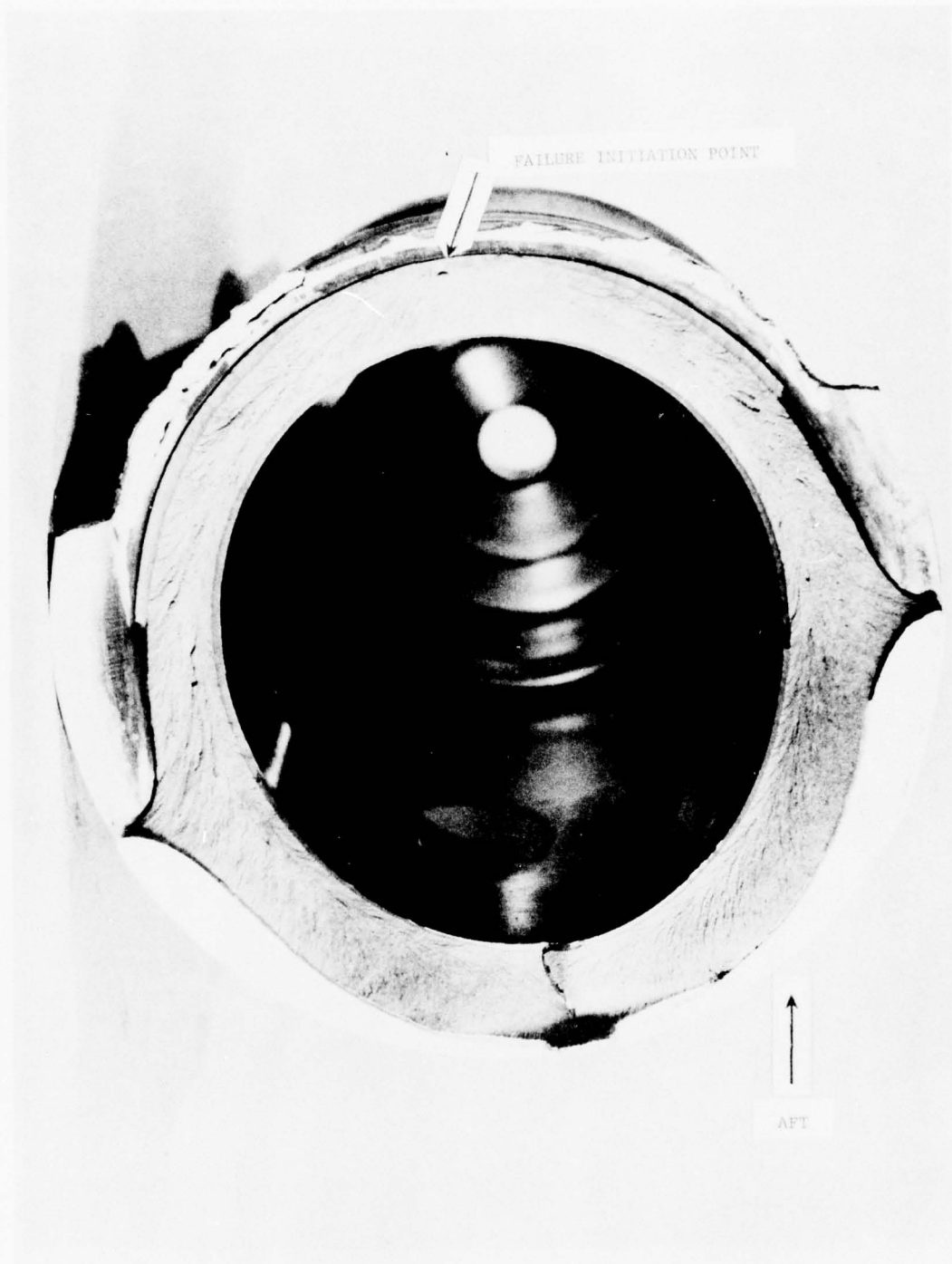

Figure 7. Outer Cylinder Failure - Lower Fracture Surface

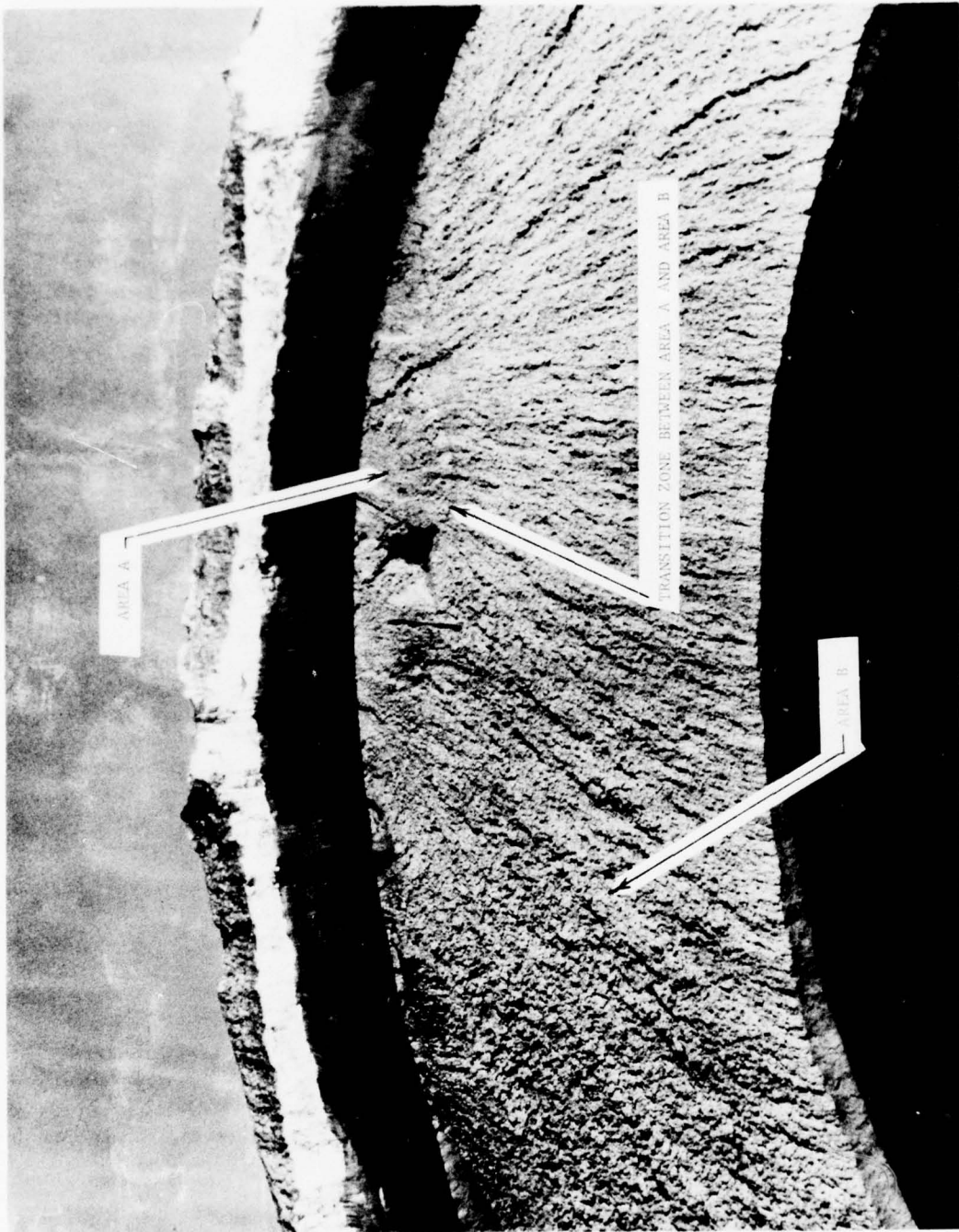

Figure 8. Close-up of Failure Initiation Surface

By applying a scatter factor of 2 to the test results, the life of the C-2A NLG can be determined as follows:

$$310 \text{ service catapult launches} + \frac{1260}{2} \text{ test catapult launches} = 940 \text{ catapult launches}$$

Since the 310 service catapult launches computed above were based on average usage, there can be no allowable increase for the C-2A NLG service life.

It should be noted that this fatigue life limitation (900 launches) is applicable to the C-2A NLG components tested only and does not imply any other structural limitations on the aircraft or components already verified for greater fatigue lives.

C O N C L U S I O N S

Based on the results of this fatigue investigation, the C-2A NLG service life cannot be extended beyond its current authorized service life of 900 catapult launches.

This service life is limited to the nose landing gear only and does not imply any other structural limitations on the C-2A aircraft.

R E C O M M E N D A T I O N S

It is recommended that replacement components for the C-2A nose landing gear be purchased and installed just prior to the expiration of each component's established service life. In particular, for the outer cylinder, which requires a long lead time (26 - 30 months), procurement procedures should be initiated immediately since the outer cylinder must be replaced after 900 catapult launches.

It is further recommended that a method of tracking the C-2A nose landing gear components and recording the number of catapult launches be initiated.

A C K N O W L E D G E M E N T S

The author wishes to acknowledge the valuable assistance, during the test program, of Messrs. L. Berman, V. Catone and E. Kautz of the Aero Structures Division, and also the Aero Materials Laboratory for performing the metallurgical analysis.

R E F E R E N C E S

1. GAC Report 3839.12A, "Results of the Nose Gear Catapult Fatigue Tests", Rev. 3 Jun 1974.
2. NAVAIRSYSCOM msg 23215Z of 26 Aug 1974.
3. GAC Report 3803.3A "Ground Loading Condition", Rev. 9 Jan 1968.

NADC-76235-30

A P P E N D I X A

TEST DATA FOR THE C-2A NOSE LANDING GEAR FATIGUE

INVESTIGATION

L I S T O F F I G U R E S

<u>Figure No.</u>	<u>Title</u>	<u>Page No.</u>
A-1	C-2A Nose Landing Gear Geometry	4
A-2	Condition 1 SU, 3 Point Landing - Maximum Spin-Up	7
A-3	Condition 1 SB, 3 Point Landing - Maximum Spring-Back	8
A-4	Condition 1 SU ₂ , 3 Point Landing, Second Cycle Spin-Up	9
A-5	Condition 11D, Catapult Approach Dashing	11
A-6	Condition 11A, Catapult Release	12
A-7	Condition 11C _a , Catapult Start of Run - Maximum Tow Load	15

L I S T O F T A B L E S

<u>Table No.</u>	<u>Table</u>	<u>Page No.</u>
A-I	C-2A Nose Landing Gear Fatigue Investigation Applied Test Loads	6

S Y M B O L S

All symbols used in this appendix and in the text of the report are as follows:

- FS fuselage station
- WL water line
- FRL fuselage reference line
- R_e resultant load

S I G N C O N V E N T I O N

The following sign convention is used: Distances and forces are positive when they are up, aft and to the left with respect to the reference axes. See Figure A-1.

R E F E R E N C E S A X E S

- X - axis: Lies in the plane of symmetry 2.54 m (100 inches) below and parallel to the FRL
- Y - axis: Perpendicular to the plane of symmetry through the X - axis at FS 0
- Z - axis: Perpendicular to the X-Y plane through the intersection of the X and Y axes.

B A S I C D A T A

- Landing design gross weight - 20 012 kg (44,120 pounds)
- Catapulting design gross weight - 24 655 kg (54,354 pounds)
- Critical Conditions (reference (a))

- Landing Condition . . . GAC Condition 1 SU - 3 point landing, maximum spin-up
- GAC Condition 1 SB - 3 point landing, maximum spring-back
- GAC Condition 1 SU₂ -3 point landing, second cycle spin-up

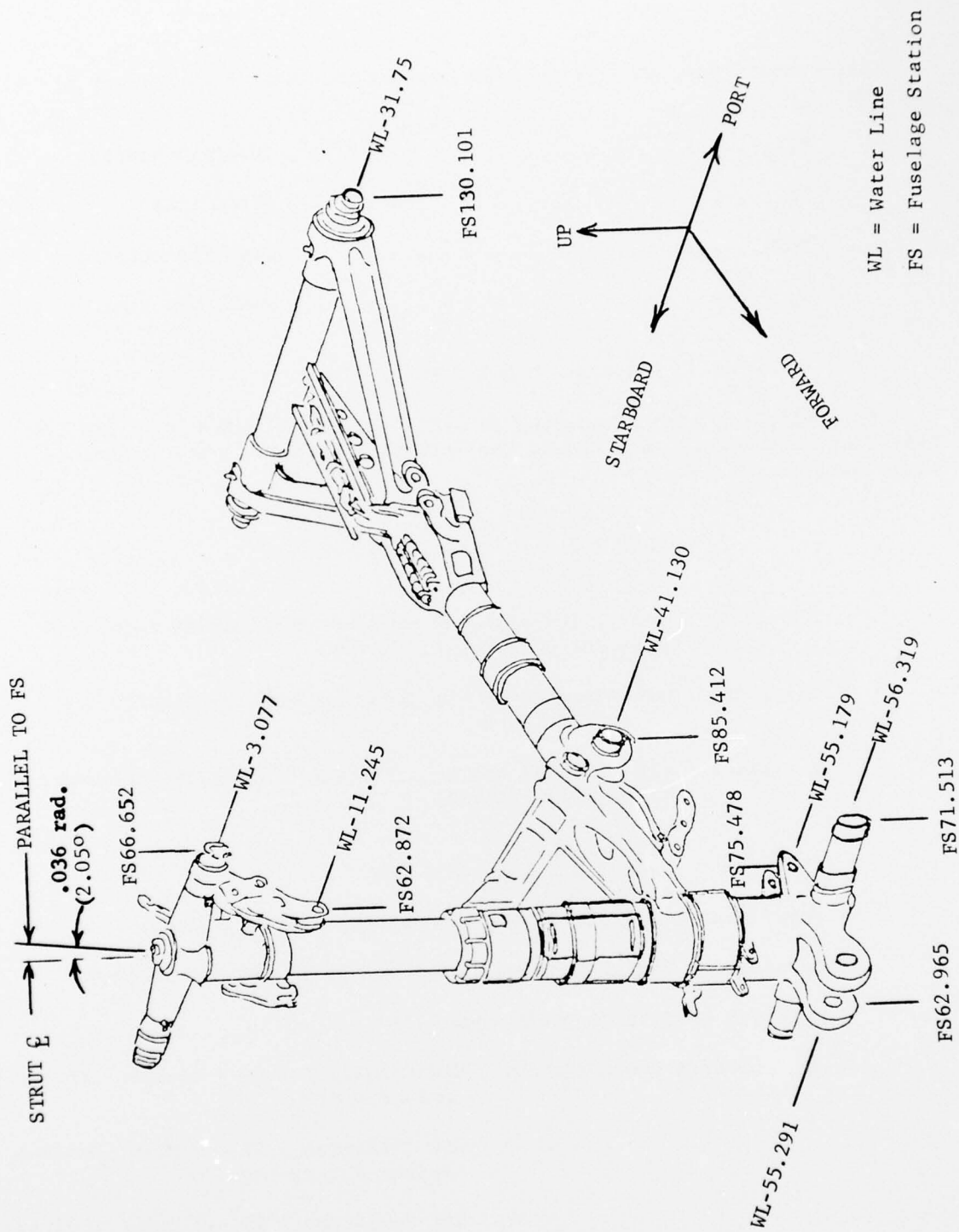

Figure A-1. C-2A Nose Landing Gear Geometry

Catapulting Conditions GAC Condition 11D - Catapult approach dashing
 GAC Condition 11A - Catapulting Release
 GAC Condition 11C_a - Catapult Start of Run

T E S T L O A D S

All test loads presented in this section are in accordance with those found in references (a) and (b) with the exception of Condition 11C_a. The loads for condition 11C_a are as presented by NAVAIR-530223 (reference (c)) and agreed to by GAC and NAVAIRDEVGEN.

The loads associated with each condition of landing and catapult launch are given in Table A-I. Particular details of each condition are given below.

The down lock actuator load of 35 810 N (8,050 lbs.) (reference (d)) was applied for the duration of each landing and catapult launch cycle.

LANDING CONDITIONS

The design landing gross weight of 196 260 N (44,120 lbs.), wing lift equal to 2/3 W, maximum sinking speed equal to 6.096 m/s (20 ft/sec) and a forward speed equal to 48.463 m/s (159 ft/sec) was used for all landing load calculations.

Condition 1-SU - Three point landing, maximum spin up

The nose wheel axle loads relative to the FRL are as follows:

$$X_{NW} = 103\ 290\ \text{N}\ (23,220\ \text{lbs.})$$

$$Y_{NW} = 0$$

$$Z_{NW} = 148\ 880\ \text{N}\ (33,470\ \text{lbs.})$$

The load distribution of this condition, direction and magnitude, is given in Figure A-2.

Condition 1-SB - Three point landing, maximum spring back

The nose wheel axle loads relative to the FRL are as follows:

$$X_{NW} = -90\ 430\ \text{N}\ (20,330\ \text{lbs.})$$

TABLE A-I
C-2A NOSE LANDING GEAR FATIGUE INVESTIGATION
APPLIED TEST LOADS

Condition	Point of Application	Maximum Applied Loads -N/(lbs.)		
		X	Y	Z
1 SU 3 point landing- Maximum spin-up	Axle	103 290 (23,220)	0	148 880 (33,470)
1 SB 3 point landing- Maximum spring-back	Axle	-90 430 (-20,330)	0	372 630 (83,770)
1 SU ₂ 3 point landing- Second cycle spin-up	Axle	80 510 (18,100)	0	372 630 (83,770)
11D Catapult approach	Holdback	193 540 (43,510)	±4050 (± 910)	-11 880 (-2,670)
Dashing	Axle	-3 560 (-800)	0	98,800 (22,210)
11A Catapult Release	Holdback	241 940 (54,390)	±5070 (±1140)	-14 860 (-3,340)
	Tow Link	-145 860 (-32,790)	±3200 (± 720)	-46 970 (10,560)
	Axle	- 4 400 (-990)	0	122 730 (27,590)
11C _a Catapult Start of Run	Tow Link	-928 480 (-208,730)	±19750 (±4440)	-299 010 (-67,220)
Upper 90 percentile	Axle	-1 290 (-290)	0	36 080 (8,110)

NOTES:

- (1) All loads will be applied with the shock strut fixed at the static position.
- (2) The nose gear actuating cylinder load of 35 810 N (8,050#) for the gear in the down and locked position, will be applied for each loading condition.
- (3) Positive loads are up and aft.

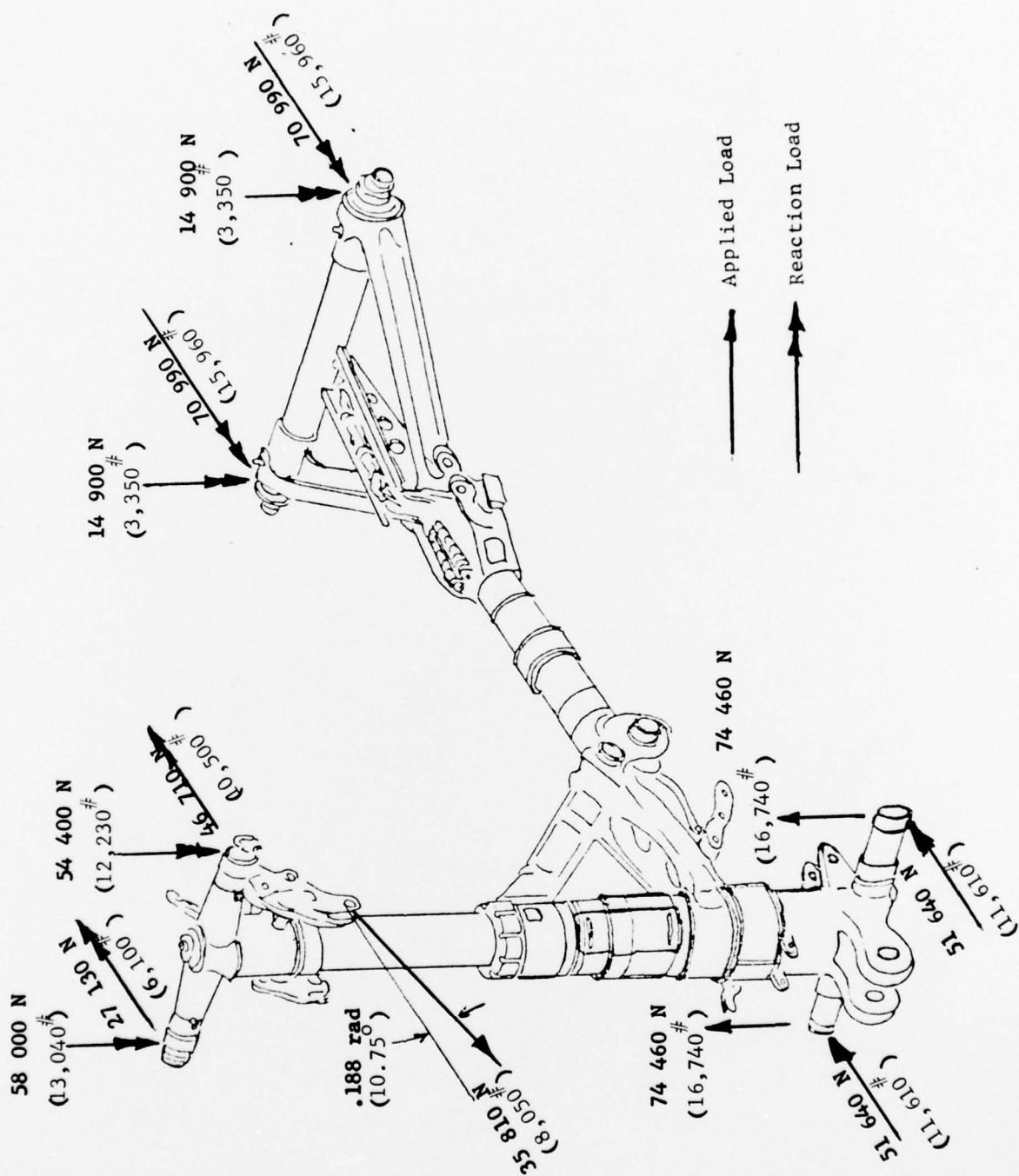

Figure A-2. Condition 1 SU, 3 Point Landing - Maximum Spin-Up

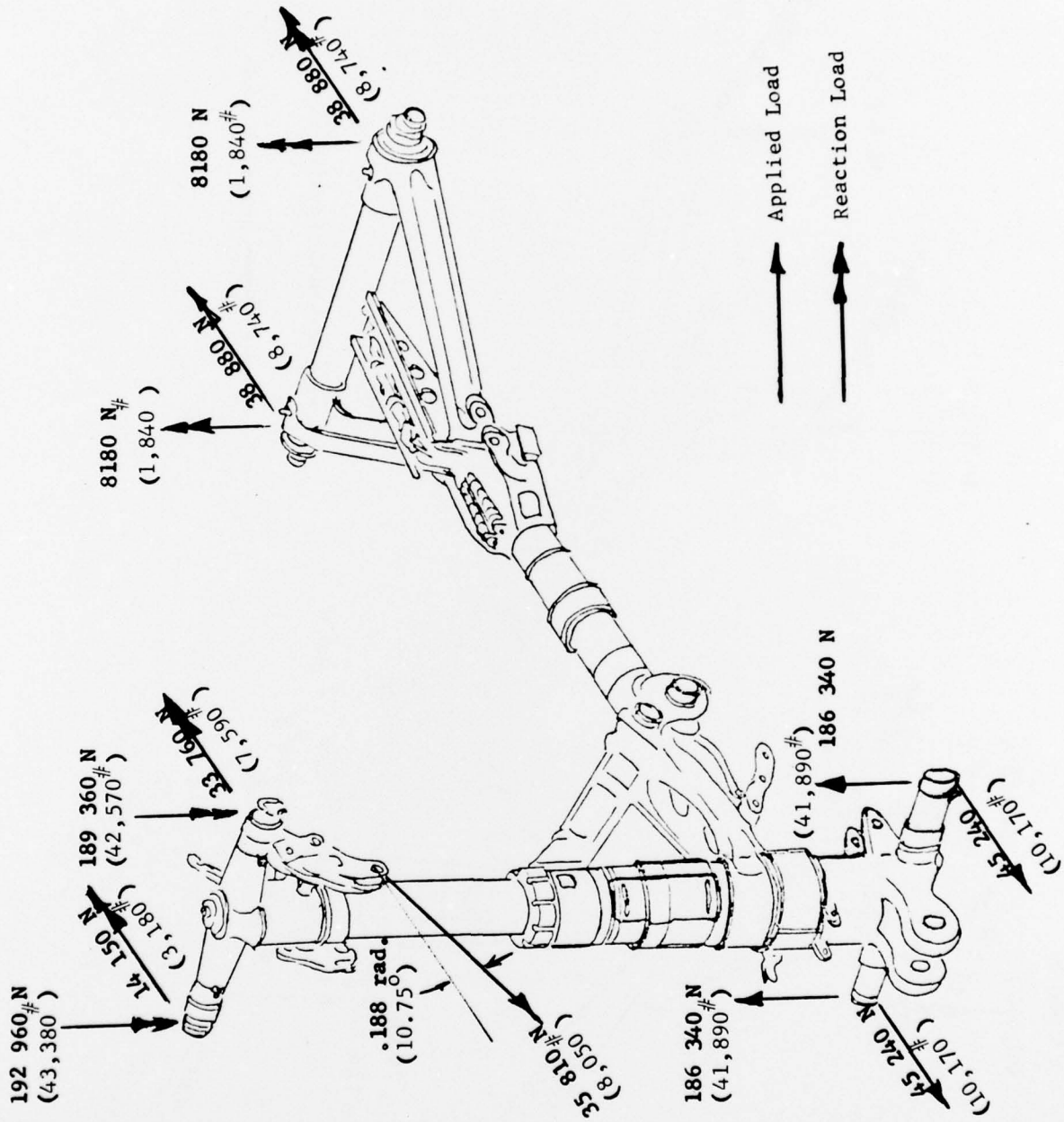

Figure A-3. Condition 1 SB, 3 Point Landing - Maximum Spring-Back

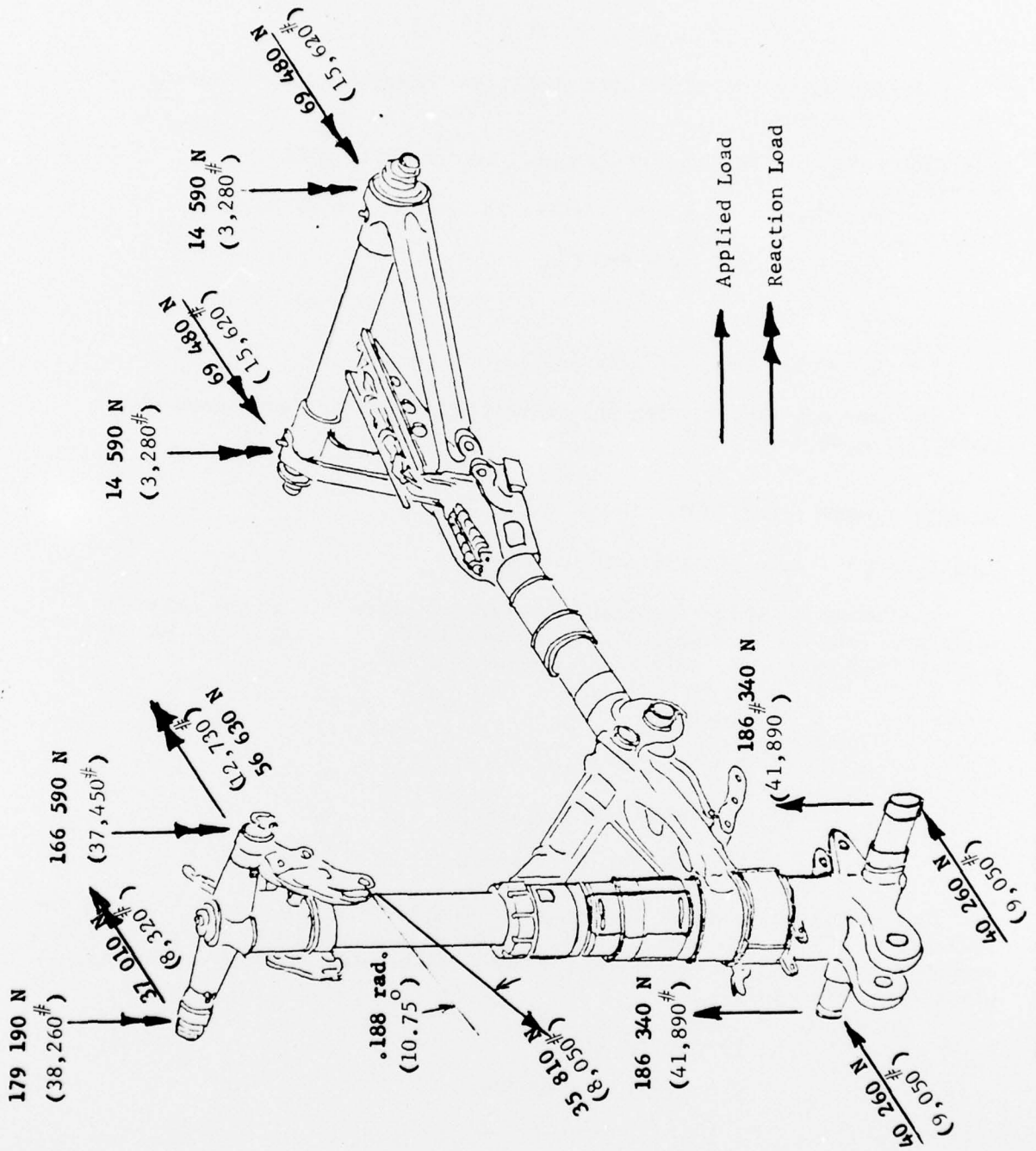

Figure A-4. Condition 1 SU₂, 3 Point Landing - Second Cycle Spin-Up

$$Y_{NW} = 0$$

$$Z_{NW} = 372\ 630\ \text{N (83,770 lbs.)}$$

The load distribution of this condition, direction and magnitude, is given in Figure A-3.

Condition 1-SU₂ - Three point landing, second cycle spin up

The nose wheel axle loads relative to the FRL are as follows:

$$X_{NW} = 80,510\ \text{N (18,000 lbs.)}$$

$$Y_{NW} = 0$$

$$Z_{NW} = 372\ 630\ \text{N (83,770 lbs.)}$$

The load distribution for this condition, direction and magnitude, is given in Figure A-4.

CATAPULT LAUNCH CONDITIONS

Condition 11D - Catapult approach dashing

The loads for this condition were derived using 80% of the holdback release element failure load as the maximum load. The components of the holdback and nose wheel axle loads are as follows:

Holdback

$$X = 193\ 540\ \text{N (43,510 lbs.)}$$

$$Y = \pm 4050\ \text{N (\pm 910 lbs.)}$$

$$Z = -11\ 880\ \text{N (-2,670 lbs.)}$$

The resultant holdback load acts at an angle of .061 rad (3.5°) down and .021 rad (1.2°) to the left or right of the fuselage reference axes. The side component results from a 0.1524 m (6 inch) off-center spotting of the airplane (reference (e)).

Nose Wheel Axle

$$X = -3560\ \text{N (-800 lbs.)}$$

$$Y = 0$$

$$Z = 98\ 800\ \text{N (22,210 lbs.)}$$

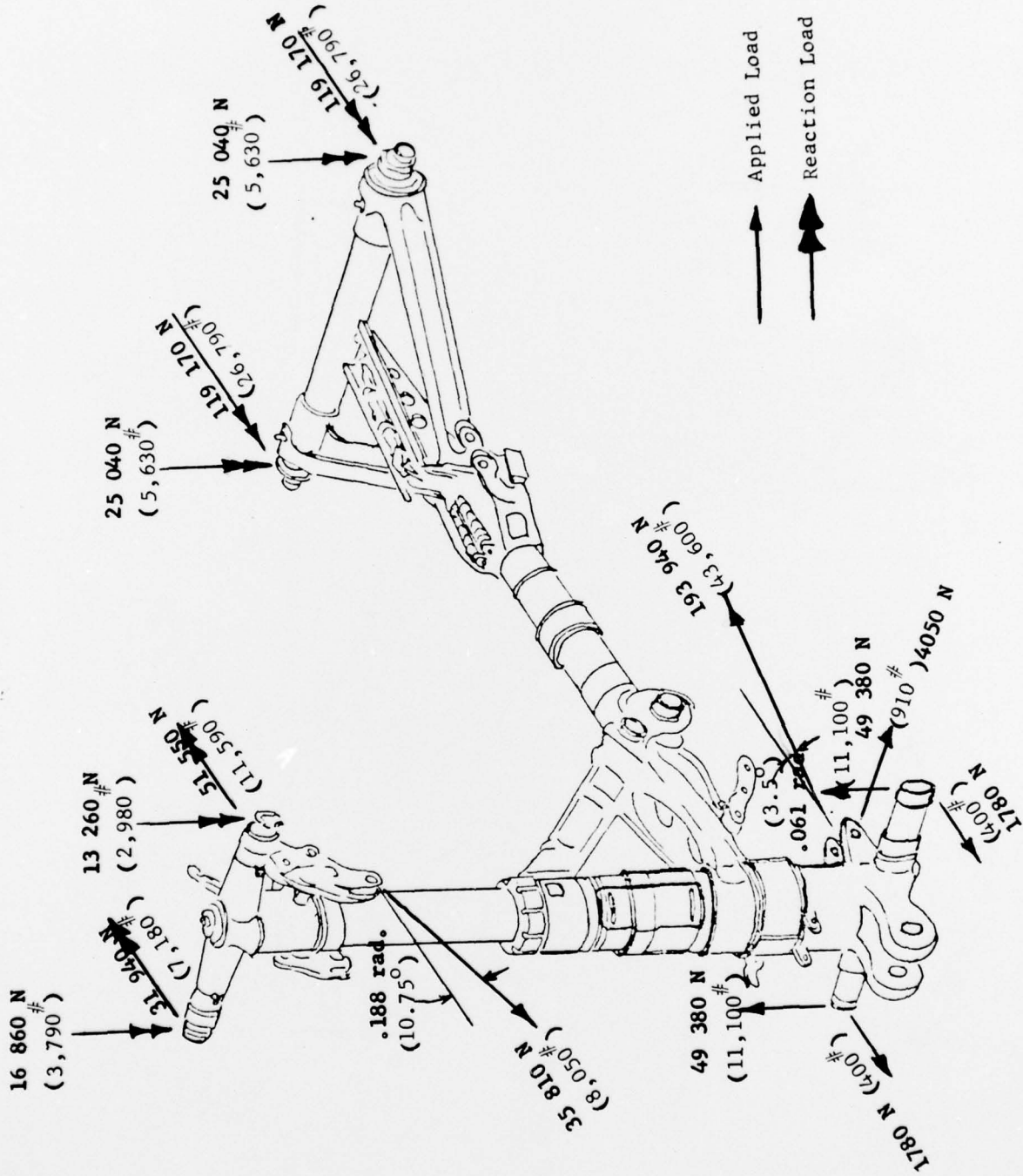

Figure A-5. Condition 11D, Catapult Approach Dashing

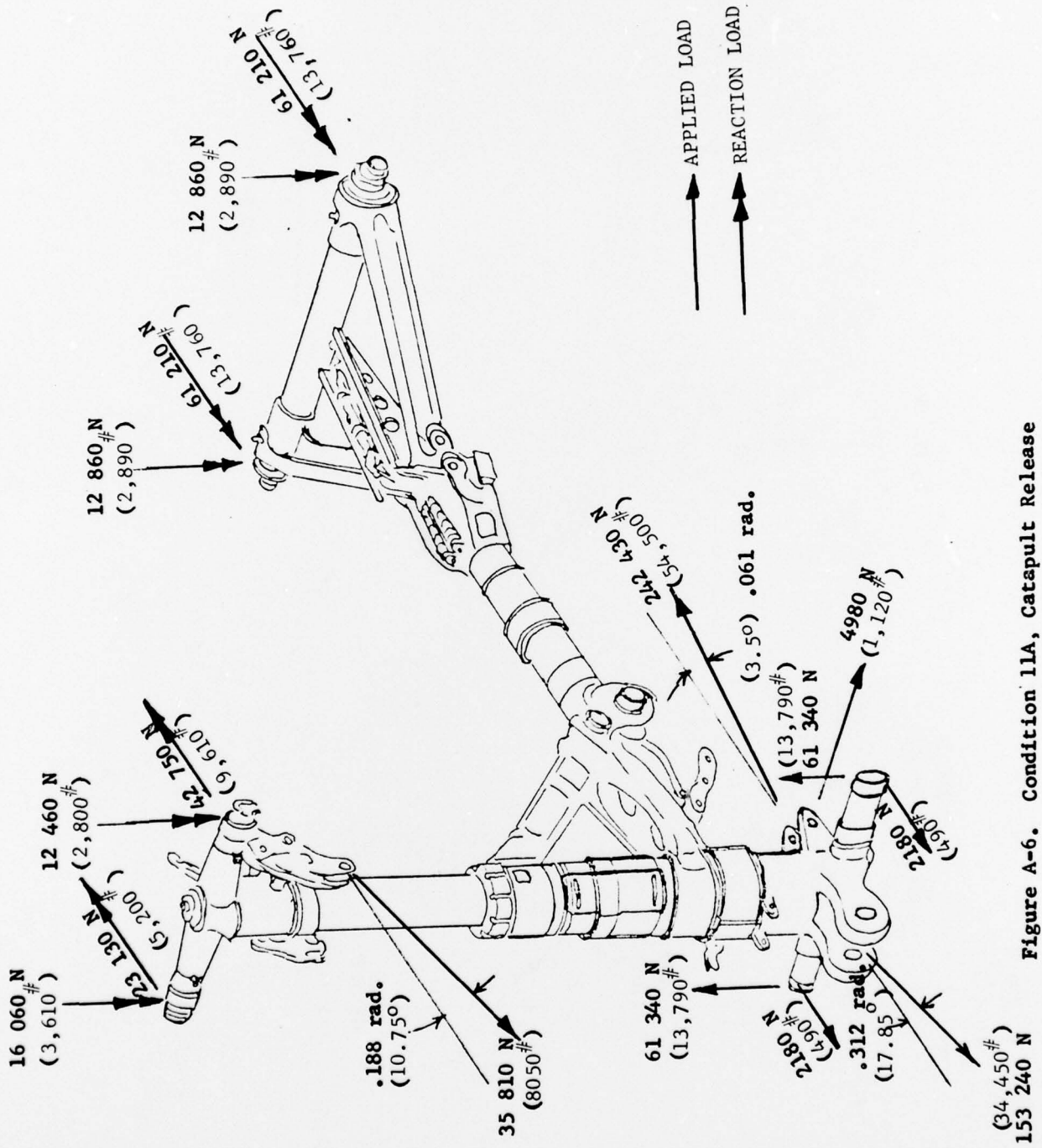

Figure A-6. Condition 11A, Catapult Release

The loading distribution for this condition, direction and magnitude, is given in Figure A-5.

Condition 11A - Catapult Release

The loads for this condition were derived using the holdback release element failure load of 242 430 N (54,500 lbs.) and a simultaneously applied tow link load of 153 240 N (34,450 lbs.). The components of the holdback, tow link and nose wheel axle loads are as follows:

Holdback

$$X = 241\,940\text{ N (54,390 lbs.)}$$

$$Y = \pm 5070\text{ N (\pm 1,140 lbs.)}$$

$$Z = -14\,860\text{ N (-3,340 lbs.)}$$

The resultant load acts in the same manner as that indicated for Condition 11D.

Tow Link

$$X = -145\,860\text{ N (-32,790 lbs.)}$$

$$Y = \pm 3200\text{ N (\pm 720 lbs.)}$$

$$Z = -46\,970\text{ N (-10,560 lbs.)}$$

The resultant tow load acts at an angle of .312 rad. (17.85°) down and .021 rad. (1.2°) to the right or left of the fuselage reference axes.

Nose Wheel Axle

$$X = -4400\text{ N (-990 lbs.)}$$

$$Y = 0$$

$$Z = 122\,730\text{ N (27,590 lbs.)}$$

The loading distribution for this condition, direction and magnitude, is given in Figure A-6.

Condition 11C_a - Catapult Start of Run

The loads for this condition were derived using a maximum tow force equal to 938 570 N (211,000 lbs.) and a mean tow force of 871 850 N (196,000 lbs.), applied at the minimum tow link angle of .276 rad. (15.8°) relative to the ground. The components of the maximum tow link and nose wheel axle loads are as follows:

Tow Link

X = -928 480 N (-208,730 lbs.)

Y = ±19 750 N (±4,440 lbs.)

Z = -299 010 N (-67,220 lbs.)

The resultant tow link load acts at an angle of .312 rad. (17.85°) down and successively .021 (1.2°) to the left and to the right of the fuselage reference axes. The side component of the towing load results from a 0.1524 m (6 inch) off-center spotting of the airplanes.

Nose Wheel Axle

X = -1290 N (-290 lbs.)

Y = 0

Z = 36 080 N (8,110 lbs.)

The loading distribution for this condition is given in Figure A-7.

R E F E R E N C E S

- (a) GAC Report 3803.3A - "Ground Loading Conditions"; Rev. 29 Jan. 1968.
- (b) GAC Report 3839.02A - "Plan for Catapulting Fatigue Tests"; Rev. 17 Feb. 1970.
- (c) NAVAIRSYSCOM msg 232151Z of 26 Aug. 1974.
- (d) Cleveland Pneumatic Tool Co. Report 1364 - "Stress Analysis of the Grumman C-2A Nose Gear of 2 Jan. 1964.
- (e) Paragraph 3.1.7.1 of MIL-C-18805A.

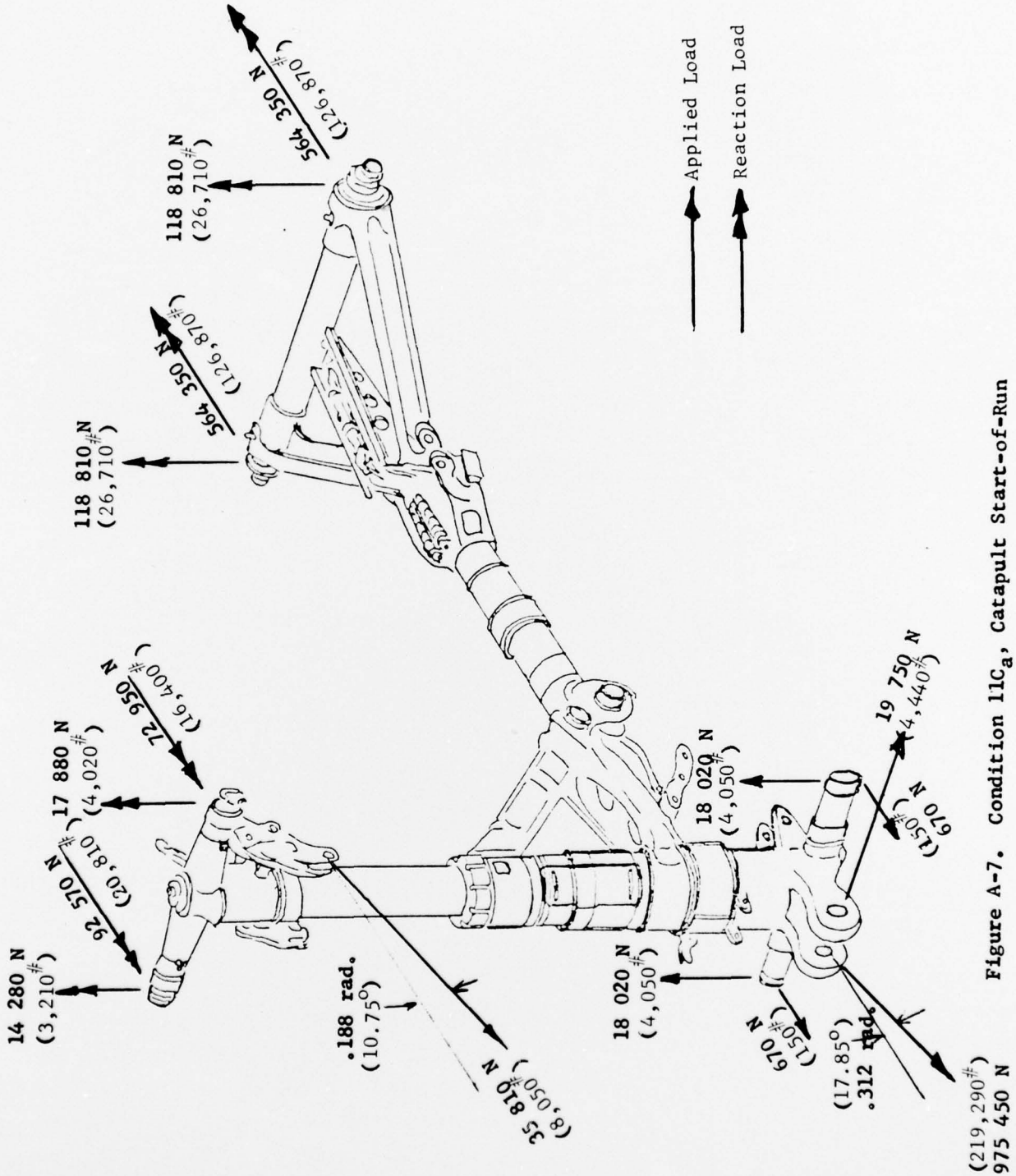

Figure A-7. Condition 11Ca, Catapult Start-of-Run

D I S T R I B U T I O N L I S T

REPORT NO. NADC-76235-30

AIRTASK A510-5103/001-4/4510-000-002

W.U. A530222A-69

	<u>No. of Copies</u>
NAVAIR (AIR-954)	8
(2 for retention)	
(1 for AIR-410)	
(1 for AIR-510)	
(1 for AIR-530)	
(3 for AIR-53022)	
NAVAIREWORKFAC, NAS, Jacksonville, Fl. (Code 300)	2
NAVAIREWORKFAC, NAS, Alameda, Cal. (Code 300)	1
NAVAIREWORKFAC, MCAS, Cherry Point, N. C. (Code 300)	1
NAVAIREWORKFAC, NAS, Norfolk, Va. (Code 300)	1
NAVAIREWORKFAC, NAS, North Island, San Diego, Cal.	1
NAVAIREWORKFAC, NAS, Pensacola, Fl. (Code 300)	1
NAVAIRSYSCOMREPAC, NAS, San Diego, Cal.	1
NAVAIRTESTCEN, Patuxent River, Md.	1
U.S. Naval Academy, Annapolis, Md.	1
Grumman Aerospace Corp., Bethpage, L.I., N.Y.	2
(1 for retention, 1 for Mr. J. Diglio)	
DDC	12
NAVAIRDEVCON, Warminster, Pennsylvania 18974	42
(3 for 813)	
(2 for 30023)	
(1 for 03)	
(1 for 20)	
(1 for 30)	
(1 for 40)	
(1 for 50)	
(1 for 60)	
(1 for 30P7)	
(1 for 301)	
(1 for 302)	
(1 for 303)	
(1 for 304)	
(1 for 305)	
(25 for 3031)	