

AD-A037 942

ROME AIR DEVELOPMENT CENTER GRIFFISS AFB N Y  
AUTOMATIC STRAIN-RATE CONTROLLER, (U)  
DEC 76 R L HUNTSINGER, J A ADAMSKI  
RADC-TR-76-396

F/G 13/8

UNCLASSIFIED

NL

| of |  
ADA037942



END

DATE  
FILMED  
4-77

ADA 037942

RADC-TR-76-396  
IN-HOUSE REPORT  
DECEMBER 1976

12

FG



## Automatic Strain-Rate Controller

R.L. HUNTSINGER  
J.A. ADAMSKI  
N. KLAUSUTIS, Major, USAF  
J.L. SAMPSON

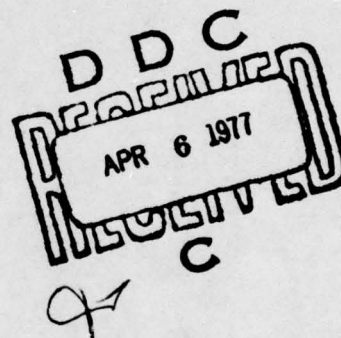

Approved for public release; distribution unlimited.

ROME AIR DEVELOPMENT CENTER  
AIR FORCE SYSTEMS COMMAND  
GRIFFISS AIR FORCE BASE, NEW YORK 13441

ADJ NO.  
DDC FILE COPY

This report has been reviewed by the RADC Information Office (OI) and is releasable to the National Technical Information Service (NTIS).

This report has been reviewed and is approved for publication.

APPROVED:

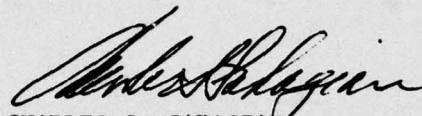

CHARLES S. SAHAGIAN  
Chief, Materials Development Branch  
Solid State Sciences Division

APPROVED:

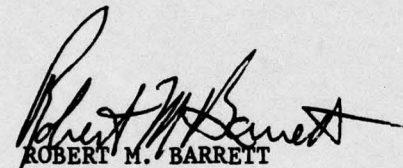

ROBERT M. BARRETT  
Director  
Solid State Sciences Division

FOR THE COMMANDER:

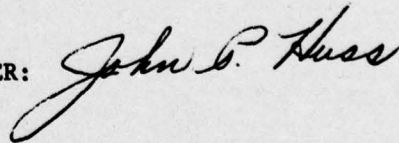

172	173	174	175	176	177	178	179	180
BY	DATE	INITIALS	DATE	INITIALS	DATE	INITIALS	DATE	INITIALS
DISTRIBUTION AVAILABILITY CODES								
CLASS. - Avail. and/or SPECIAL								
A								

*MISSION  
of  
Rome Air Development Center*

*RADC plans and conducts research, exploratory and advanced development programs in command, control, and communications (C<sup>3</sup>) activities, and in the C<sup>3</sup> areas of information sciences and intelligence. The principal technical mission areas are communications, electromagnetic guidance and control, surveillance of ground and aerospace objects, intelligence data collection and handling, information system technology, ionospheric propagation, solid state sciences, microwave physics and electronic reliability, maintainability and compatibility.*



Unclassified

SECURITY CLASSIFICATION OF THIS PAGE (When Data Entered)

REPORT DOCUMENTATION PAGE		READ INSTRUCTIONS BEFORE COMPLETING FORM
1. REPORT NUMBER RADC-TR-76-396 ✓	2. GOVT ACCESSION NO.	3. RECIPIENT'S CATALOG NUMBER
4. TITLE (and Subtitle) AUTOMATIC STRAIN-RATE CONTROLLER	5. TYPE OF REPORT & PERIOD COVERED Scientific. - Interim.	
7. AUTHOR(s) R. L./Huntsinger ↓ J. L./Sampson J. A./Adamski N. Klausutis Maj. USAF	6. PERFORMING ORG. REPORT NUMBER	
8. PERFORMING ORGANIZATION NAME AND ADDRESS Deputy for Electronic Technology (RADC/ETSP) Hanscom AFB Massachusetts 01731 ✓	8. CONTRACT OR GRANT NUMBER(s) n/a	
11. CONTROLLING OFFICE NAME AND ADDRESS Deputy for Electronic Technology (RADC/ETSP) Hanscom AFB Massachusetts 01731	10. PROGRAM ELEMENT PROJECT TASK AREA & WORK UNIT NUMBERS 61102F 2306J106	
14. MONITORING AGENCY NAME & ADDRESS (if different from Controlling Office)	12. REPORT DATE December 1976	
	13. NUMBER OF PAGES 22	
	15. SECURITY CLASS. (of this report) Unclassified	
	15a. DECLASSIFICATION DOWNGRADING SCHEDULE	
16. DISTRIBUTION STATEMENT (of this Report) A - Approved for public release; distribution unlimited. 12/2pp. 162306 12/J1		
17. DISTRIBUTION STATEMENT (of the abstract entered in Block 20, if different from Report)		
18. SUPPLEMENTARY NOTES * Leeds & Northrup Co., Columbia, MD.		
19. KEY WORDS (Continue on reverse side if necessary and identify by block number) Hot forging                      Automatic control Hot pressing                     Single crystals Strain rate Ram rate		
20. ABSTRACT (Continue on reverse side if necessary and identify by block number) This report describes the principle of operation of an automatic strain-rate controller to control or monitor ram rate or strain rate in a vacuum hot-pressing furnace. The system achieves automatic operation with continuous control. This provides smoother pressing at lower strain rates than could be achieved in manual operation, with less attention from the operator. Appendices give details of calibration and operation.		

DD FORM 1 JAN 73 1473 EDITION OF 1 NOV 65 IS OBSOLETE

Unclassified

SECURITY CLASSIFICATION OF THIS PAGE (When Data Entered)

309 050

4B

SECURITY CLASSIFICATION OF THIS PAGE(When Data Entered)



SECURITY CLASSIFICATION OF THIS PAGE(When Data Entered)

## Preface

The authors gratefully acknowledge the assistance of Jack Reed of Leeds and Northrup Company, Dedham, Massachusetts, and of Gerald Lavoie of Centorr Associates, Inc., Suncook, New Hampshire.

## Contents

1. INTRODUCTION	7
2. OBJECTIVE	8
3. THEORY OF OPERATION	8
4. CONCLUSION	13
APPENDIX A: Automatic Controller Components	15
APPENDIX B: Calibrating and Operating Procedures	19

## Illustrations

1. Photograph of Vacuum Hot-Pressing System	8
2. Sample Configuration	9
3. Photograph of Chamber	11
4. Control System Diagram	12
A1. Hydraulic System Schematic	17
A2. Control System Schematic	17

## Automatic Strain-Rate Controller

### 1. INTRODUCTION

An automatic strain-rate controller was designed, built, and placed in operation to control and monitor deformation rate or strain rate of samples in the vacuum hot-pressing apparatus previously described.<sup>1</sup> Figure 1 shows the complete vacuum hot-pressing system, including the new automatic strain rate controller.\* In the automatic control mode, it responds quickly and with a high degree of sensitivity. In the monitoring mode, it allows the operator to observe either the rate of ram motion or the strain rate. The apparatus is provided with current trips which terminate sample deformation in the event of over-pressure conditions or at a desired final height.

This system replaces a manual, step-wise control process with a smooth-acting continuous operation. It improves the quality of the forged billets and reduces the amount of operator time required.

---

(Received for publication 29 December 1976)

\*The automatic strain-rate controller and the original vacuum hot-pressing system were procured with financial support from AFWL.

1. Adamski, J. A., and Klausutis, N. (1975) Vacuum Hot Pressing Apparatus and Technique, AFCRL-TR-75-0582.

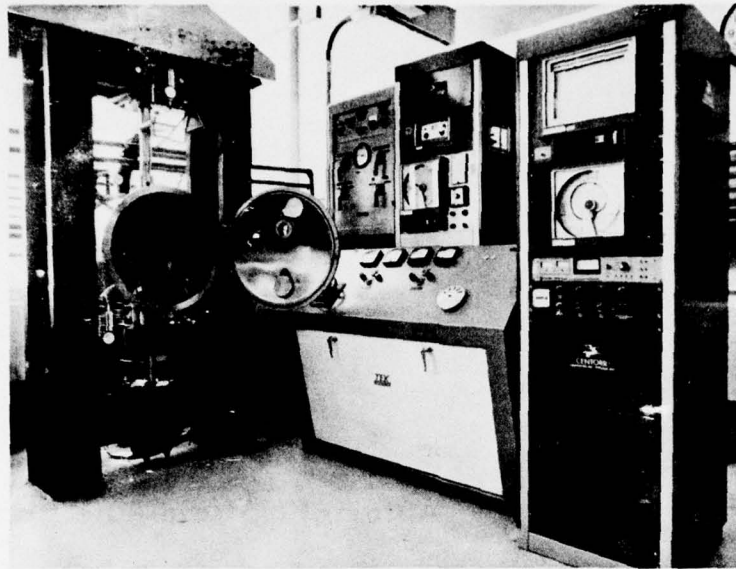

Figure 1. Photograph of Vacuum Hot-Pressing System

## 2. OBJECTIVE

The objective of this work was to design and implement an automatic system to control the deformation of single crystals at constant deformation rates or at constant strain rates, defined below, or to monitor either of these rates. The system had to be sensitive to very small fluctuations in ram motion and simultaneously be rugged enough to survive in an industrial environment.

## 3. THEORY OF OPERATION

The process to be controlled is a uniaxial deformation of a single crystal at a constant temperature. A crystal of initial length  $\ell_0$  is placed between two forging rams inside a die cavity sufficiently large that the cross-sectional area of the sample is not an important parameter for process control. The rams are initially allowed to contact the sample without applying any force. Force is then applied to reduce the length of the sample while increasing its cross-sectional area. Figures 2(a) and (b) show the configuration in its initial state and at a later time.

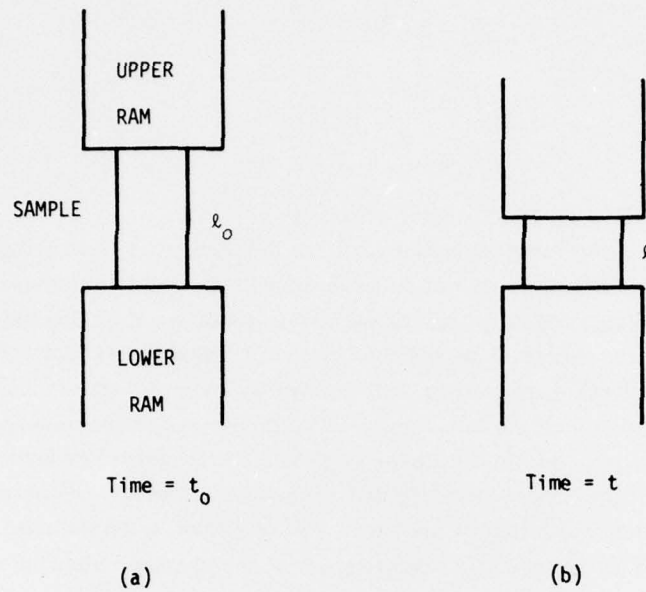

Figure 2. Sample Configuration

Two modes of operation are desired: ram-rate, in which the rate of change of the sample length is constant (Eq. (1)), and strain-rate, in which the fractional rate of change is constant (Eq. (2)).

$$\text{Ram rate} \equiv \frac{dl}{dt} = R = \text{constant} \quad (\text{Eq. 1})$$

$$\text{Strain rate} \equiv \frac{1}{l} \cdot \frac{dl}{dt} = \frac{d \ln l}{dt} = S = \text{constant} \quad (\text{Eq. 2})$$

In the ram-rate mode, the distance between the forging rams diminishes at a constant rate, and the sample is deformed by the same increment of length per unit time,

$$\frac{l - l_0}{t - t_0}$$

over the course of the entire deformation. In the strain-rate mode, the fractional reduction of sample length per unit time,

$$\frac{\frac{l - l_0}{l_0}}{t - t_0}$$

is constant over the course of the deformation.

Samples are forged at constant  $R$  or  $S$ , as desired, at a fixed temperature to a predetermined percentage reduction in sample length. The automatic control system uses a voltage signal proportional to  $l$  to maintain  $R$  or  $S$  constant. The voltage signal is the output of an adder-subtractor. The inputs to the adder-subtractor are voltage signals from two linear displacement transducers, one on the upper ram and one on the lower ram. The inputs are properly adjusted so that the ram motion is within the linear region of the transducers (approximately 5 cm), and are of the proper polarity that the output of the adder-subtractor is proportional to the separation of the rams. Zero output is established with the rams just touching. Figure 3 is a photograph of the chamber showing the rams and the linear displacement transducers, along with continuous dial indicators which are used as a mechanical backup for the electronic measurements.

A logarithmic amplifier can be switched into the circuit to convert the output of the adder-subtractor from a signal proportional to  $l$  to one proportional to  $\ln l$ . This signal, referred to as the sample voltage  $V_S$ , is the one whose time derivative must be controlled. The procedure henceforth will refer to ram-rate control with the logarithmic amplifier out of the circuit. It is apparent that strain-rate control will result from switching it in.

To control rate, it is necessary to control the time derivative of  $V_S$ . The simplest method would employ an operational amplifier to obtain the derivative and then use this as the input to a controller. This approach was considered, but rejected. Slight variations in ram speed, due to friction, would act as a noisy input to the operational amplifier and result in erratic control signals and erratic motion of the rams.

Another approach, which would eliminate the problem of noise due to frictional stick-slip motion, would not differentiate  $V_S$  but compare it with a ramping voltage diminishing at the proper rate to match the desired  $V_S$  at all times. The difference would be fed into a zero set-point controller. While this system would probably be sensitive enough and would avoid the noise problem, its operation would be difficult. The ramping voltage would have to be calculated, calibrated, and set up anew for each run, and the stability of the system might not be adequate.

The approach finally adopted employs an analog integrator and a recorder in an unconventional configuration (Figure 4). The recorder is so connected that its output  $V_R$  drives upscale if the input is positive and downscale if the input is

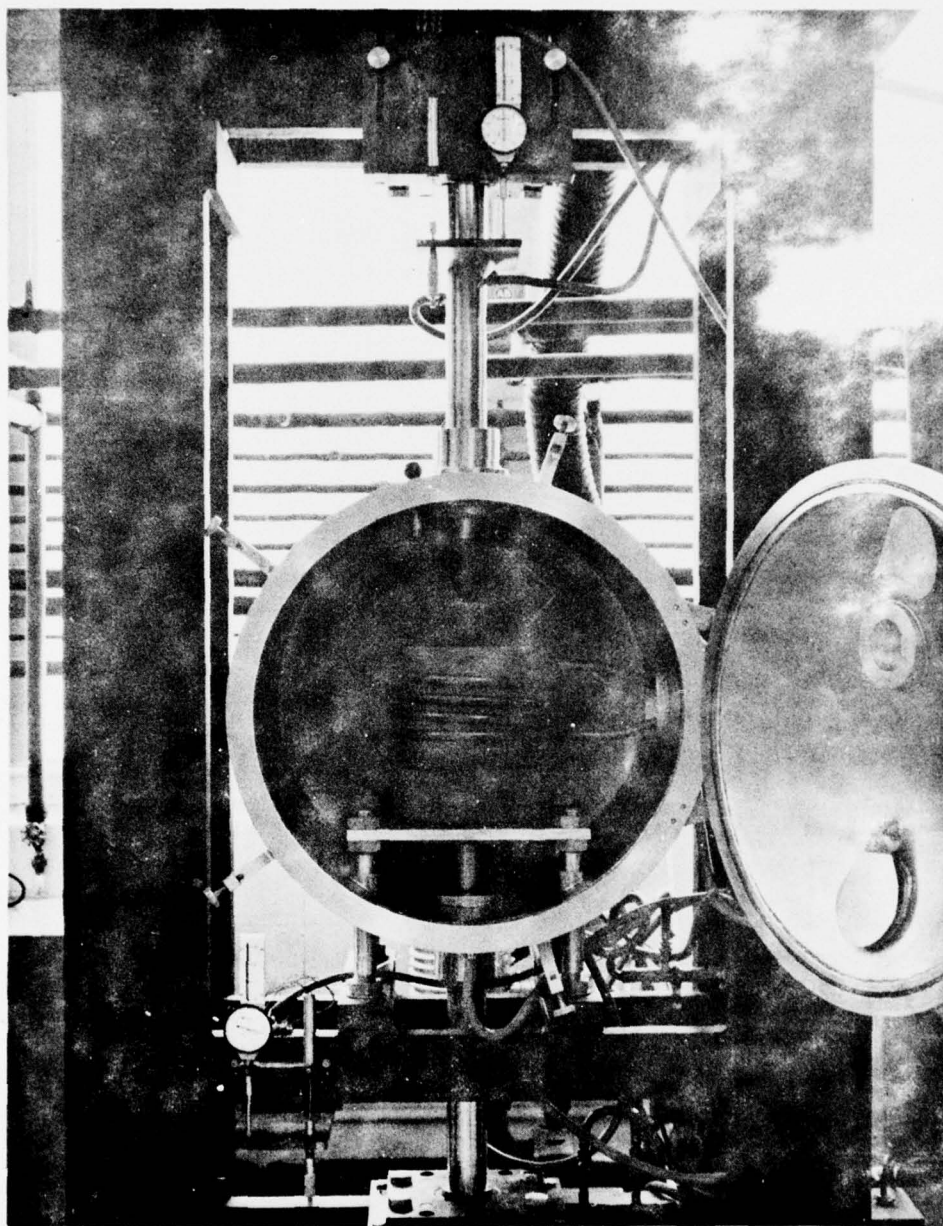

Figure 3. Photograph of Chamber

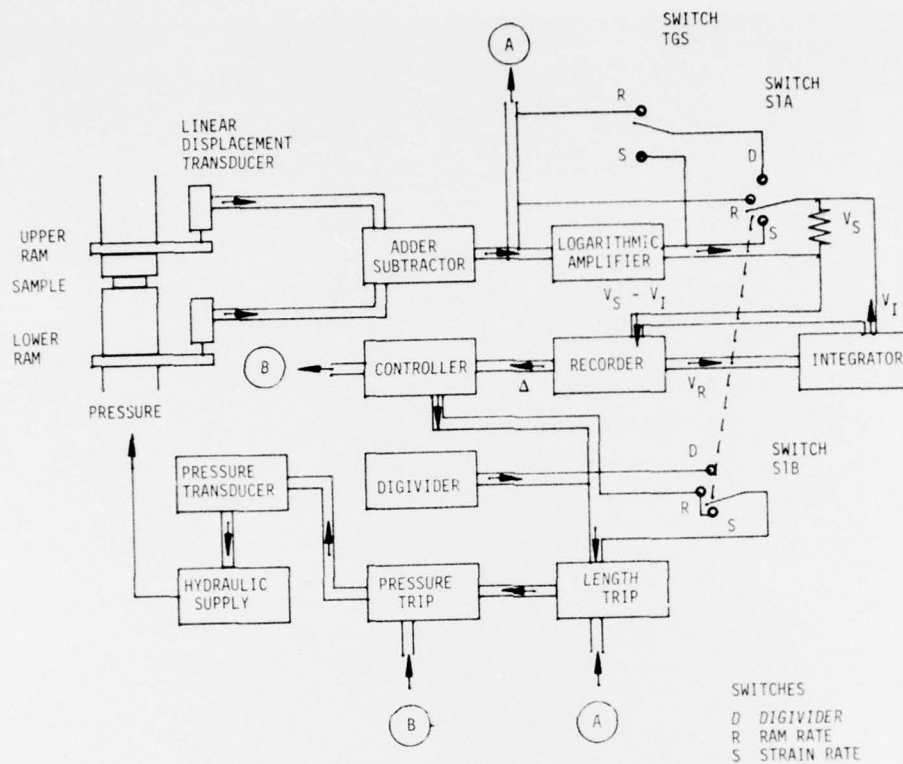

Figure 4. Control System Diagram

negative; only when the input is zero will the output remain constant at less than full-scale. This output,  $V_R$ , serves as the input to the integrator. The integrator output,  $V_I$  is then the time integral of  $V_R$ :

$$V_I = \int V_R dt \quad (\text{Eq. 3})$$

or

$$V_R = \frac{dV_I}{dt} \quad (\text{Eq. 4})$$

The output,  $V_P$ , is bucked against the sample signal  $V_S$ , and the difference,  $V_S - V_P$  is the input to the recorder. The recorder output will become steady only when  $V_S - V_I = 0$ , and the system will thus adjust itself to a recorder reading for which this is true. At this point, for steady-state operation,  $V_S$  must continually be equal to  $V_P$  and their derivatives must thus also be equal. Since  $V_R$  is equal to the derivative of  $V_P$ , it must also be equal to the derivative of  $V_S$ ; that is, the recorder reading will be proportional to the rate of deformation of the sample.

Another output from the recorder is a deviation signal  $\Delta$  proportional to the difference between the recorder reading and a set-point. It is this signal which is finally used as the input to a controller. Proportional band, reset, rate, and approach actions are provided by the controller, a Leeds and Northrup Series 80, to adjust for the proper process response of its output. The output of this controller replaces the Digivider in the manual system. Although the manual control system could have been replaced entirely, it was deemed worthwhile to retain it as a backup system. It was therefore connected via a switch.

#### 4. CONCLUSION

*This system has several advantages over the previously-used manual system. It provides continuous control of the ram pressure, rather than the discrete steps of the manual system. It frees the operators from the necessity of continuously monitoring, calculating, and adjusting from the beginning of a run to the end. This permits longer runs and consequently lower strain rates and higher deformations.*

## Appendix A

### Automatic Controller Components

The principal components of the automatic control system, listed below, are diagrammed in Figures A1 and A2.

LINEAR DISPLACEMENT TRANSDUCERS (LDTs), Hewlett-Packard Model #7DCDT-1000.

Output -4.8 to +4.8 Vdc to adder-subtractor.

Powered by Hewlett-Packard power supply 60063-B,  $\pm 5$  Vdc.

LDTs mounted one on upper ram, one on lower ram.

ADDER-SUBTRACTOR, Leeds and Northrup Part #101135.

Inputs from LDTs; 5 Vdc bias input from Hewlett-Packard power supply Model #62005A.

Output 0 to -10 Vdc to potentiometer R1; then to logarithmic amplifier, switches TGS and S1, and length trip relay.

LOGARITHMIC AMPLIFIER, Leeds and Northrup Part #101293.

Input 0 to 1 Vdc from adder-subtractor via R1.

Output 0 to 1 Vdc to recorder and integrator via switches and potentiometers R2, R4, and R6.

FUNCTION CONTROL SWITCH (S1).

Selects Digivider, ram-rate, or strain-rate modes of operation.

SELECTOR SWITCH (TGS)

Permits selection of recording mode (ram-rate or strain-rate) while operating in Digivider (manual) mode.

RECORDER, Leeds and Northrup Servo Speedomax H.  
Input from logarithmic amplifier or adder-subtractor, bucked against output of integrator.  
Output 0 to 3 Vdc to integrator via potentiometer R5.  
Output (deviation from set-point) to controller.  
Circuit includes interruptor to vary chart speed.

INTEGRATOR, Leeds and Northrup Part #10891.  
Input from recorder via potentiometer R5.  
Output, bucked against adder-subtractor or logarithmic amplifier output, to recorder.  
Four ranges of minutes of control. With recorder at full-scale, control times are 1, 5, 10, and 100 min. Control times increase with decreasing recorder readings and approach infinity as the recorder reading goes to zero.

CONTROLLER, Leeds and Northrup Series 80 CAT with proportional band, rate, reset, and approach controls.  
Input from deviation output of recorder.  
Output to hydraulic supply via switch SIB.

TRIP RELAYS, Rochester Instrument Systems.  
Model #ET-215V shuts machine off on overpressure.  
Model #ET-215 shuts machine off at preset deformation.

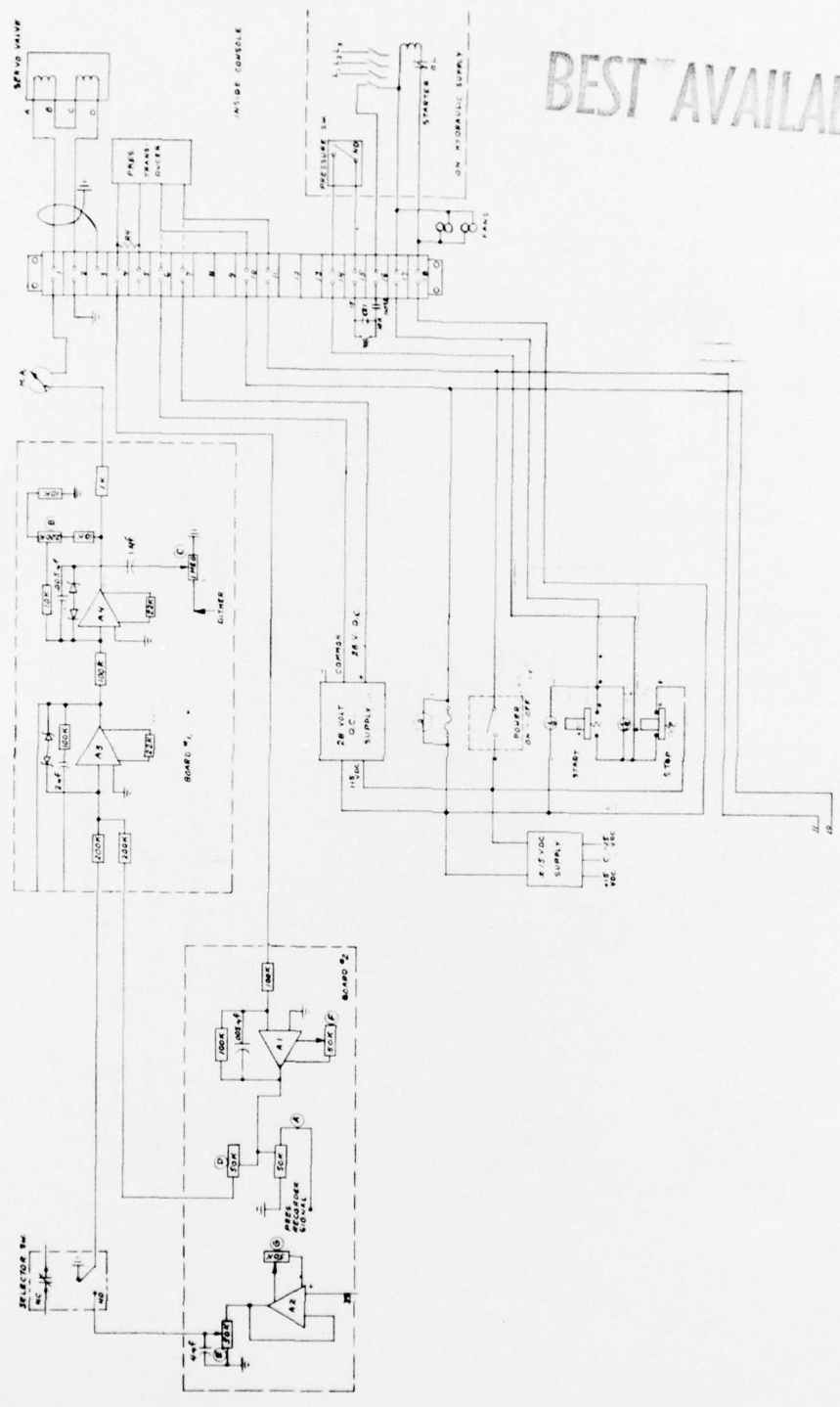

BEST AVAILABLE COPY

Figure A1. Hydraulic System Schematic



## Appendix B

### Calibrating and Operating Procedures

#### 1. CALIBRATION COMPONENTS

This system contains six potentiometers, located as indicated in Figure A2, which must be adjusted properly for the system to be in calibration. Their functions are as follows:

R1 - Voltage divider on the output of the adder-subtractor provides correct input voltage to the logarithmic amplifier.

R2 - Matches the output of the adder-subtractor or the logarithmic amplifier to that of the integrator during balanced operation to provide zero input to recorder.

R3 - Sets the maximum pressure which the system can apply to the rams.

R4 - Voltage divider on the output of the adder-subtractor or the logarithmic amplifier determines overall system sensitivity.

R5 - Sets input voltage to slidewire of recorder. Adjusts control time of integrator.

R6 - Voltage divider on the output of the Hewlett-Packard power supply biases the output of the integrator to a negative value.

There are two current trips in the system to terminate the forging operation at a present deformation or in the event of an accidental over-pressure. Operation of either trip activates visible and/or audible alarms:

CT1 - Terminates a run if a maximum pressure is exceeded. Set by a screw-driver adjustment to trip at a predetermined output of the Series 80 controller.

CT2 - Terminates a run at a predetermined sample length. Set by a knob on the unit.

There is an interlock bypass switch to permit operation of the hydraulic system during calibration and after automatic shutdown by CT2. It must be in the "OFF" position during forging.

## 2. CALIBRATION PROCEDURE

(1) Position the die assembly in the furnace chamber with both rams in contact with the punches. Adjust the verniers on the LDTs to give zero outputs between test points (TPs) 48 and 49, and between TPs 47D and 50. Test points are indicated in Figure A2.

(2) Raise the upper ram and place a two-inch block between the upper ram and the upper punch. Lower the ram until contact is just made with the punch. Adjust R1 to give 1.0 Vdc between TPs 39 and 40. \* Adjust R4 to give 0.1 Vdc between TPs 39 and 54.

(3) With the integrator output at zero (see Operating Procedure in Section 3), adjust R6 to give zero Vdc between TPs 39 and 44.

(4) Turn the recorder off. Raise the upper ram, remove the two-inch block, and lower the upper ram until it is nearly in contact with the upper punch. Set the integrator at full-scale by turning the recorder pointer, by hand, to full-scale and the integration factor to 1. Adjust R5 to give 3 Vdc between TPs 18 and 20. Current on the integrator meter will go from 0 to near full-scale in about 1 min. Adjust R2 to give zero Vdc between TPs 39 and 44.

(5) Adjust the output of the Series 80 controller to 90 percent full-scale. Using a screwdriver, adjust trip unit CT1 to trip at this level of controller output.

(6) The hydraulic servo system has been previously calibrated<sup>1</sup> at 1 mv/psi. Calculate the voltage corresponding to the maximum desired pressure. Adjust R3 until this voltage appears between TPs 34 and 37.

(7) Insert a dummy sample. A block of wood not higher than two inches will suffice. Set function switch S1 on "RAM RATE." Follow Operating Procedure in Section 3, steps (8) through (16).

(8) Move the set-point slowly up to 3 or 4.

(9) If the recorder pointer hunts, adjust the function controls on the Series 80 recorder to stabilize the pointer.

\* If either LDT has its core out of its two-inch linearity range, R1 will fail to adjust this voltage properly.

1. Adamski, J. A., and Klausutis, N. (1975) Vacuum Hot Pressing Apparatus and Technique, AFCRL-TR-75-0582.

- (10) Using the dial indicators and a timer, determine the ram rate for the setting of the set-point.
- (11) Adjust the set-point slowly, and determine ram rate as a function of setting.
- (12) Set switch S1 on "STRAIN RATE" and repeat the calibration.

### 3. OPERATING PROCEDURE

Sample preparation, loading, removal, and evaluation techniques, as well as the selection of forging parameters to modify microstructure and residual strain, have been discussed in a previous report.<sup>1</sup>

These techniques have not been changed by the introduction of automatic rate control. The procedure, as modified for automatic operation, is as follows:

- (1) Raise the upper ram to create a gap exactly as high as the desired final height of the sample to be pressed.
- (2) Turn the interlock switch to the "OFF" position.
- (3) Adjust the CT2 trip setting knob until the alarm light comes on.
- (4) Turn the interlock switch to "ON."
- (5) Place the sample to be forged between the punches in the die cavity. Lower the upper ram so that it nearly touches the upper punch. Replace the carbon felt insulation and the thermocouple, close and evacuate the furnace chamber. If controlled atmosphere is to be used, place the vacuum interlock switch in the "ON" position. Gradually heat the sample to forging temperature and allow thermal equilibrium to be established.
- (6) Turn the interlock bypass switch to "OFF." This puts CT2 in the circuit for automatic shut-down.
- (7) Select ram-rate or strain-rate control, as desired, with switch S1.
- (8) Set the control function settings on the Series 80 controller (Proportional Band, Rate, Reset, and Approach). These settings depend upon the material being forged and must be determined experimentally for each new material.
- (9) Make certain that the recorder is turned on.
- (10) Select a setting of the integrator. The setting (1, 5, 10, or 100) is approximately the maximum length of control time in minutes with the recorder at full-scale, and increases as the recorder scale decreases. Refer to the results of the calibration of rate versus recorder setting.
- (11) Set the recorder set-point on zero.
- (12) Press the "DOWN" button on the Series 80 controller until its output meter indicates zero.
- (13) Press the "RESET" button on the integrator to bring the output to zero.

(14) Turn the integrator program switch to "REMOTE."

(15) Turn the upper hydraulic control valves simultaneously to "ON" for automatic pressure control.

(16) Switch the Series 80 controller to "AUTOMATIC."

(17) It will now require some time, depending upon the height of the sample to be forged, before the input to the recorder reaches zero. When this occurs, the recorder pointer will go from full-scale (100) to zero. After this has occurred, slowly move the set-point to a position where the desired ram rate or strain rate will be achieved (refer to the calibration results). As long as the recorder input is zero, the recorder pointer will follow the set-point.

(18) The dial indicators and a timer should be used to monitor ram rate or strain rate. This permits the operator to check the automatic controller at any time.

(19) The machine may be operated manually and controlled by the output of the Digivider by setting switch S1 on "DIGIVIDER." A record of ram rate or strain rate will be recorded, depending upon the setting of switch TGS.