

AD-A038 011

NAVAL SURFACE WEAPONS CENTER DAHLGREN LAB VA
MUZZLE-FLANGE ALIGNMENT TECHNIQUE FOR PRECISION IMPACT PLANARITY--ETC(U)
JAN 77 W MOCK, W H HOLT
NSWC/DL-TR-3583

F/G 19/6

UNCLASSIFIED

NL

| OF |
AD
A038011



END

DATE
FILMED
4 - 77

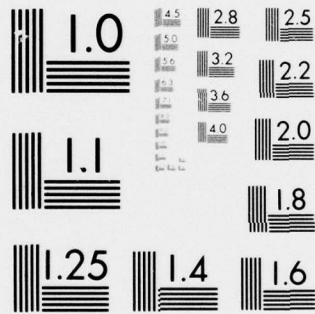

MICROCOPY RESOLUTION TEST CHART
NATIONAL BUREAU OF STANDARDS-1963-A

CK, Jr.
HOLT
ents Development Depart

NAVAL SURFACE WEAPONS CENTER
DANLIGREN LABORATORY
Danligran, Virginia
22448

B. H. Jones, Jr., Capt., USN
QC and Systems Commander

UNCLASSIFIED

SECURITY CLASSIFICATION OF THIS PAGE (When Data Entered)

REPORT DOCUMENTATION PAGE		READ INSTRUCTIONS BEFORE COMPLETING FORM
1. REPORT NUMBER TR-3583	2. GOVT ACCESSION NO.	3. RECIPIENT'S CATALOG NUMBER
4. TITLE (and Subtitle) MUZZLE-FLANGE ALIGNMENT TECHNIQUE FOR PRECISION IMPACT PLANARITY IN GAS GUN EXPERIMENTS	5. TYPE OF REPORT & PERIOD COVERED Final report	6. PERFORMING ORG. REPORT NUMBER
7. AUTHOR(s) W. Mock, Jr. W. H. Holt	8. CONTRACT OR GRANT NUMBER(s)	
9. PERFORMING ORGANIZATION NAME AND ADDRESS Naval Surface Weapons Center (DG-50) Dahlgren Laboratory Dahlgren, Virginia 22448	10. PROGRAM ELEMENT, PROJECT, TASK AREA & WORK UNIT NUMBERS	
11. CONTROLLING OFFICE NAME AND ADDRESS	12. REPORT DATE January 1977	13. NUMBER OF PAGES 24
14. MONITORING AGENCY NAME & ADDRESS (if different from Controlling Office)	15. SECURITY CLASS. (of this report) UNCLASSIFIED	15a. DECLASSIFICATION/DOWNGRADING SCHEDULE
16. DISTRIBUTION STATEMENT (of this Report) Approved for public release; distribution unlimited.		
17. DISTRIBUTION STATEMENT (of the abstract entered in Block 20, if different from Report)		
18. SUPPLEMENTARY NOTES		
19. KEY WORDS (Continue on reverse side if necessary and identify by block number) instrumentation shock waves impact gas gun		
20. ABSTRACT (Continue on reverse side if necessary and identify by block number) A new muzzle-flange configuration and flange alignment device are described for precision alignment of target assemblies in gas gun experiments. The muzzle configuration consists of a fixed barrel flange and a moveable target flange. The alignment device consists of a long precision rod which fits into the gun muzzle and three dial indicators for monitoring the target flange adjustment.		

DD FORM 1473
1 JAN 73

EDITION OF 1 NOV 65 IS OBSOLETE
S/N 0102-LF-014-6601

UNCLASSIFIED
SECURITY CLASSIFICATION OF THIS PAGE (When Data Entered)

DDDC
APR 8 1977
RECEIVED

391 598

lpg

FOREWORD

This report describes a new muzzle-flange configuration and flange alignment device for the alignment of target assemblies in gas gun impact experiments. Precision alignment is necessary to obtain distortion-free data in shock wave experiments.

This report has been reviewed by C. A. Cooper, Head, Munitions Division.

Released by:

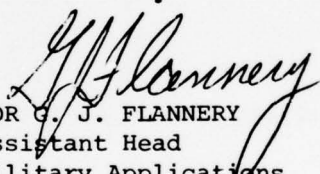
CDR G. J. FLANNERY
Assistant Head
Military Applications
Armaments Development Department

ACCESSION for	White Section <input checked="" type="checkbox"/>
NTIS	Buff Section <input type="checkbox"/>
DSC	<input type="checkbox"/>
UNANNOUNCED	
JUSTIFICATION	
BY	DISTRIBUTION AVAILABILITY CODES
Dist.	Avail. and Special
A	

TABLE OF CONTENTS

	<u>Page</u>
FOREWORD	i
LIST OF ILLUSTRATIONS	iii
EXECUTIVE SUMMARY	iv
INTRODUCTION	1
DETAILS OF PRECISION MUZZLE FLANGES AND ALIGNMENT DEVICE	2
OPERATION OF ALIGNMENT DEVICE	5
SUMMARY	8
REFERENCES	9
APPENDIX A--DRAWINGS FOR MUZZLE FLANGES AND ALIGNMENT DEVICE	A-1
DISTRIBUTION	

LIST OF ILLUSTRATIONS

<u>Figure</u>		<u>Page</u>
1	Schematic of Gas Gun	1
2	Schematic of Muzzle Showing the Double-Flange Configuration (For clarity of presentation the cap and set screws are shown displaced from their common bolt circle.) . .	3
3	View of Muzzle Showing the Barrel and Target Flanges . .	3
4	Precision Flange Alignment Device on Granite V-Blocks. .	4
5	Close-up View of Alignment Device Showing the End Plate and Dial-Indicator Contact Points	5
6	Flange Alignment Device in Operating Position at the Gun Muzzle	6
7	Tilt Pin Target Assembly for Impact Planarity Measurement	7
8	Tilt Data Waveform (Time increases from left to right. The vertical scale is 4 V/div and the horizontal scale is 20 ns/div. A 5-ns-period time calibration wave is shown at the bottom.)	8

EXECUTIVE SUMMARY

A new muzzle-flange configuration and flange alignment device are described for obtaining precision impact planarity in gas gun experiments. The muzzle configuration consists of a fixed barrel flange and a movable target flange. The alignment device consists of a precision rod which fits into the gun muzzle and three dial indicators for monitoring the target flange adjustment. Precision alignment is necessary to obtain distortion-free material response data in shock wave experiments.

INTRODUCTION

This report describes a new muzzle-flange configuration and flange alignment device for obtaining precision alignment of target assemblies in gas gun experiments. The muzzle configuration consists of a fixed barrel flange and an adjustable target mounting flange. The device is placed in the end of the gun barrel for precision alignment of the target flange.

A schematic of the NSWG 40-mm gas gun¹ is shown in Figure 1. A target assembly is placed on the muzzle for impacting at controlled velocities by impactor disks carried on flat-faced projectiles with O-ring seals. The projectile velocity can be varied from 0.03 to 1 km/s in a controlled manner. Precision alignment of the target flange is necessary to obtain a minimum planarity angle (tilt) between the impactor and specimen faces at impact, and thus to ensure that the specimen is subjected to one-dimensional strain conditions. This is important in real-time shock wave measurements to produce distortion-free data.

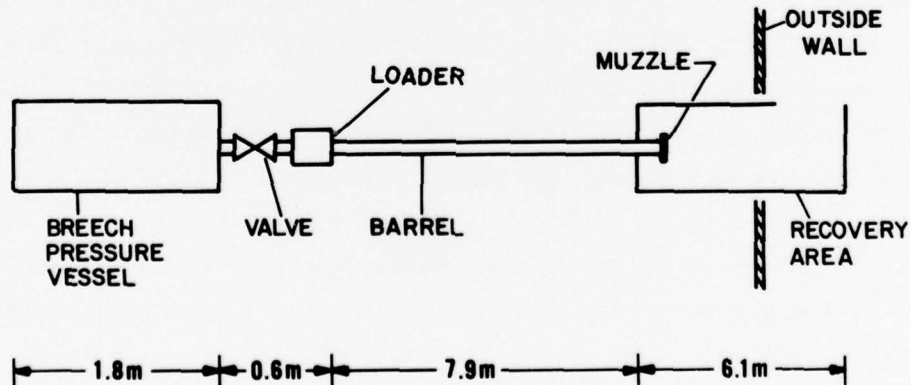

Figure 1. Schematic of Gas Gun

Minimum tilt is especially important for low projectile velocities (0.03 to 0.3 km/s) since for these velocities the closure time between the impactor and specimen faces is largest, leading to large tilt-dependent

risetimes in stress-time profiles. An electronic circuit and charged pins are used for measuring impact planarity.²

The details of the double-flange configuration and alignment device are presented in the next section. In the last section the operation of the alignment device is discussed and tilt data is presented. Appendix A contains the shop drawings for the flanges and alignment device.

DETAILS OF PRECISION MUZZLE FLANGES AND ALIGNMENT DEVICE

Figure 2 is a schematic of the muzzle region showing the double-flange configuration. Also shown is the vacuum line for evacuating the barrel to 10^{-1} Pa prior to firing the gun, and the three pins for measuring the projectile velocity at impact. The barrel flange is held rigidly on the end of the barrel with three 1/2-13 UNC threaded rods (not shown in the figure) that are screwed into the back of the flange. An O-ring provides a vacuum seal between the barrel and the barrel flange. The target flange is supported by the two O-rings (90 durometer Buna-N) between the two flanges, and its alignment is fine adjusted with the three 1/4-28 UNRF socket head cap screws (Unbrako Type 1960 stainless steel, 32-mm long). Before adjustment all three cap screws are turned a fixed amount to compress the O-rings for a vacuum seal. After adjustment the three 1/4-28 UNRF oval point socket set screws (Unbrako Type 1960 stainless steel, 17.2-mm long) are used to lock the position of the target flange. An O-ring in the front face of the target flange provides a vacuum seal between the flange and target assembly.

Figure 3 is a view of the muzzle region showing the two flanges. The three cables are connected to the velocity pins in the side of the barrel. The close proximity of the locking screws to the adjustment screws ensures that the target flange is not deformed when it is locked into its final position. The double-flange configuration was designed so that at impact the front projectile O-ring is supported by the inside of the barrel flange (the inside diameter of the barrel flange is 125 μ m larger than the barrel bore). This ensures that the O-ring is still compressed and provides a gas pressure seal at the time of impact.

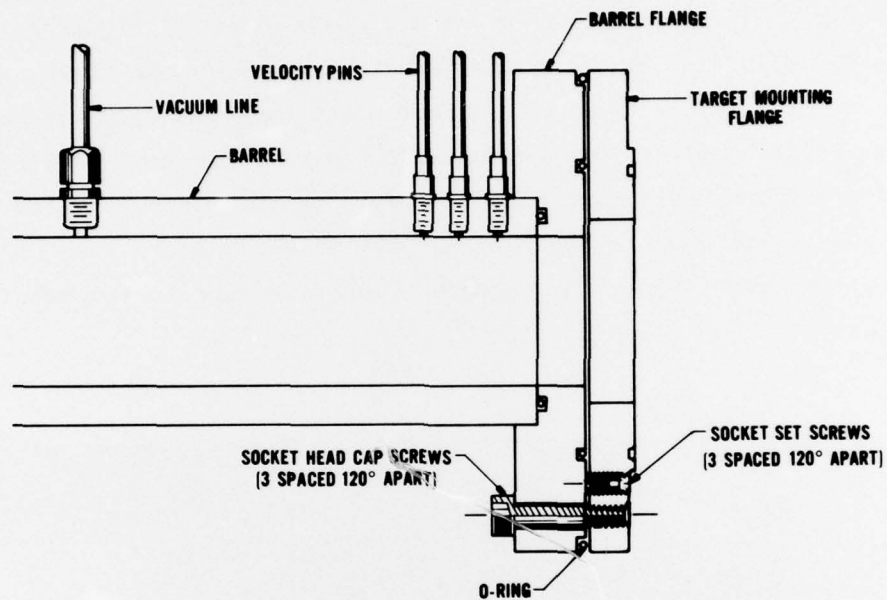

Figure 2. Schematic of Muzzle Showing the Double-Flange Configuration (For clarity of presentation the cap and set screws are shown displaced from their common bolt circle.)

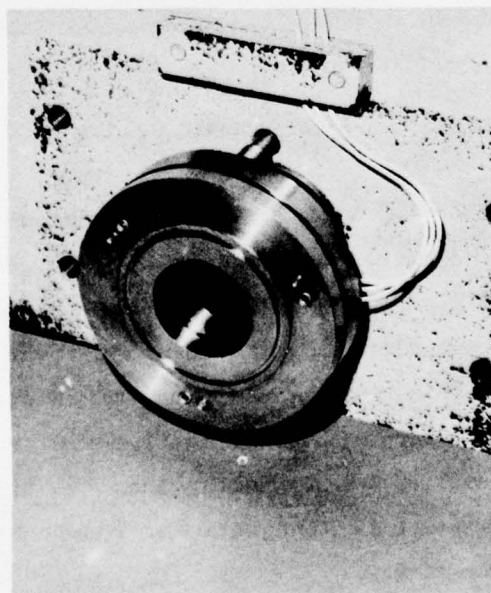

Figure 3. View of Muzzle Showing the Barrel and Target Flanges

The precision flange-alignment device is shown in Figure 4. The device is calibrated by using the granite V-blocks shown in the figure. Since the granite V-blocks and surface plate have accuracy tolerances of $0.5\ \mu\text{m}$, it is possible to synchronize the dial indicators (Starret No. 25-209 with $1.25\text{-}\mu\text{m}$ resolution and 0.38-mm range) by contacting the pin tips two-at-a-time on the end of the granite V-block and then setting the dial-indicator faces to a common graduation line in the middle of their range.

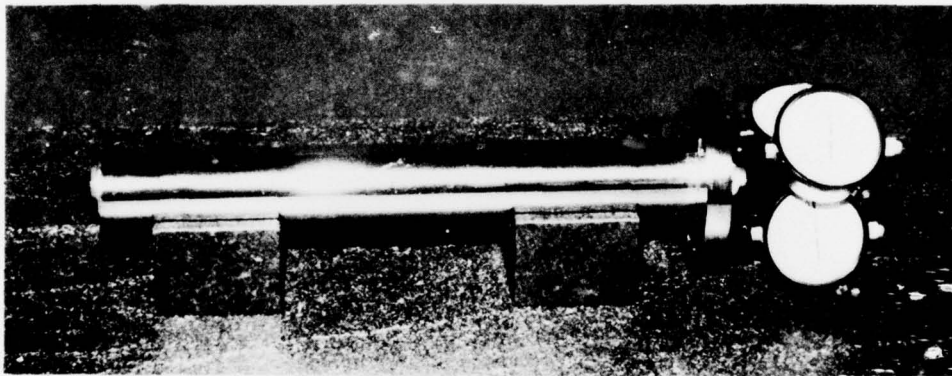

Figure 4. Precision Flange Alignment Device on Granite V-Blocks

Figure 5 is a close-up view of the alignment device showing the end plate and the dial-indicator contact points. The contact points protrude approximately $0.6\ \text{mm}$ beyond the face of the end plate so that only the points touch the target flange during the adjustment procedure. To align the target flange the 0.3-m -long precision rod is placed in the gun muzzle. The adjustment of the flange plate is monitored with the dial indicators. The diameter of the rod is $75\ \mu\text{m}$ smaller than the bore diameter; this can introduce additional tilt (the ratio of rod-to-barrel clearance and rod length) up to $250\ \mu\text{rad}$.

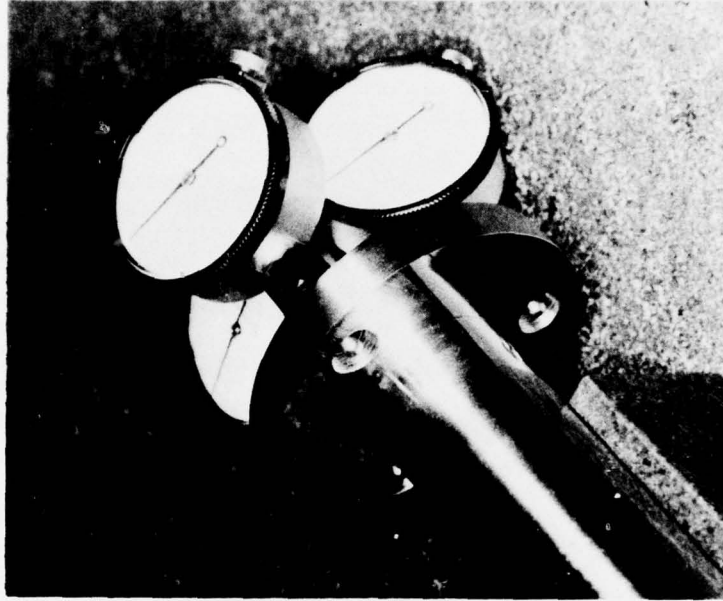

Figure 5. Close-up View of Alignment Device Showing the End Plate and Dial-Indicator Contact Points

OPERATION OF ALIGNMENT DEVICE

Before each shot the target flange (after removal from the muzzle) and the barrel are cleaned. This ensures that no particles of debris from the previous impact experiment interfere with the precision alignment procedure. When the flange is reassembled on the muzzle, the socket set screws are loosened so that they do not contact the barrel flange. The device is rotationally positioned in the barrel so the dial-indicator contact points touch the flange at positions adjacent to the set screws as shown in Figure 6. The device is carefully pushed further into the gun muzzle until the three dial indicators read approximately in the middle of their range (as was done in the calibration procedure). The difference in the readings is then due to flange tilt. The socket cap screws are then turned one-at-a-time thereby adjusting the position of the target flange until the dial indicators read within $1.25 \mu\text{m}$ of each

other. Since the indicators are positioned on a 63.5-mm-diameter circle, the tilt resolution is approximately 25 μ rad. Adding this resolution to the maximum 250 μ rad tilt contribution from the precision rod gives a maximum tilt contribution of about 275 μ rad for the device.

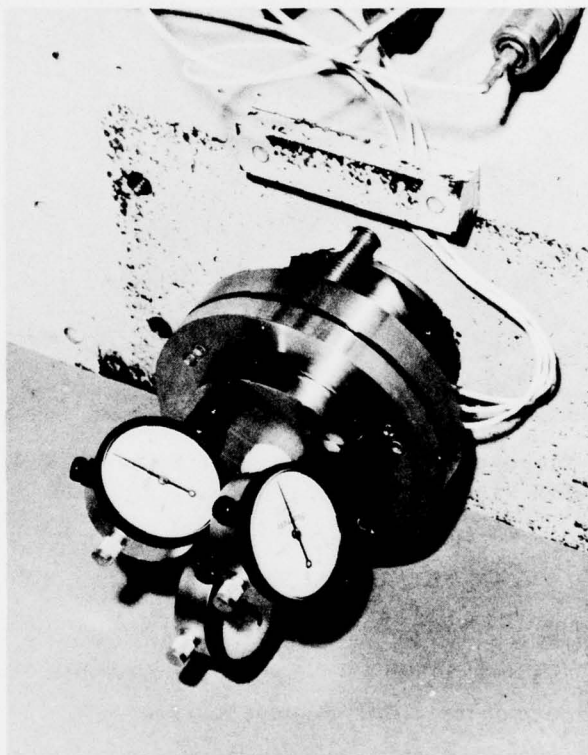

Figure 6. Flange Alignment Device in Operating Position at the Gun Muzzle

Figure 7 shows a target assembly with four tilt pins mounted on the gun muzzle for a tilt measurement after flange alignment. The tilt pin ends have been positioned in the plane of the stainless steel target ring to within 1 μ m. The pins are spaced 90° apart on a 33-mm-diameter circle. Each pin is charged to a different voltage. The tilt angle is determined at impact from the summed output waveform generated when the projectile contacts the tilt pin ends.² The projectile used for this

shot was 123-mm long and had a diameter of $78 \mu\text{m}$ smaller than the gun bore. The face of the projectile was perpendicular to the projectile outer cylindrical surface to within $2 \mu\text{m}$.

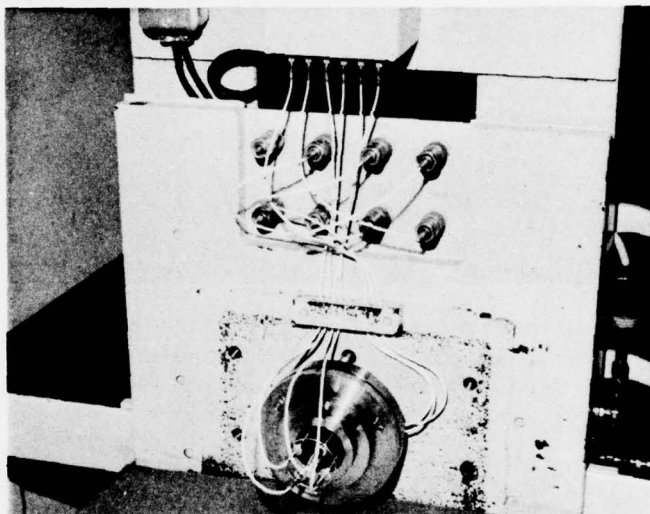

Figure 7. Tilt Pin Target Assembly for Impact Planarity Measurement

Figure 8 is the oscilloscope trace from the output of the tilt target assembly shown in Figure 7. The tilt pins were impacted with the aluminum projectile at 0.307 km/s . Each step on the tilt waveform corresponds to the contact of a pin by the projectile face. The tilt angle is calculated from the pin closure times and the measured distances between the tilt pins. The measured tilt angle for this shot was $650 \mu\text{rad}$, which is consistent with the dimensions of the projectile used. The tilt angle can be reduced by using longer projectiles.

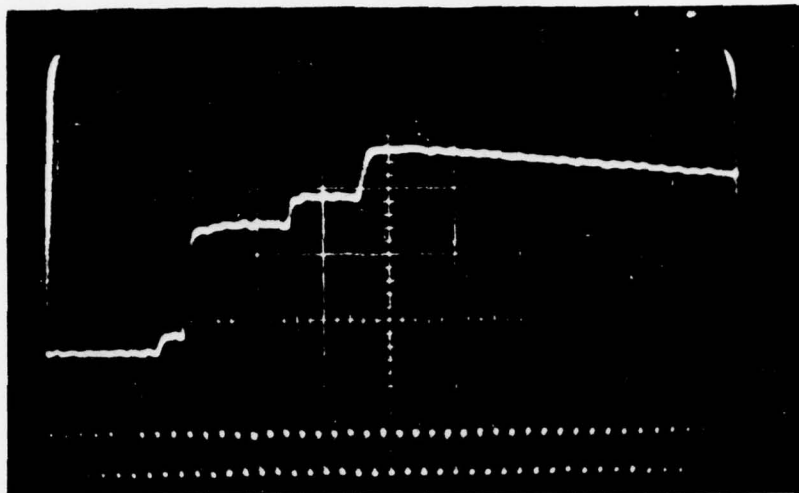

Figure 8. Tilt Data Waveform (Time increases from left to right. The vertical scale is 4 V/div and the horizontal scale is 20 ns/div. A 5-ns-period time calibration wave is shown at the bottom.)

SUMMARY

A new muzzle-flange configuration and flange alignment device have been described for obtaining precision impact planarity in gas gun experiments. The alignment procedure provides a convenient means for adjusting the target flange for minimum tilt.

REFERENCES

1. W. Mock, Jr. and W. H. Holt, *The NSWC Gas Gun Facility for Shock Effects in Materials*, Naval Surface Weapons Center, Dahlgren Laboratory Technical Report TR-3473, Dahlgren, Virginia, July 1976.
2. E. J. Shuler, W. Mock, Jr. and W. H. Holt, "Electronic Circuit Using Charged Pins for Determining Impact Planarity in Shock Wave Experiments, *The Review of Scientific Instruments*, Vol. 45, p. 203, 1974.

APPENDIX A

DRAWINGS FOR MUZZLE FLANGES AND ALIGNMENT DEVICE

(All dimensions in inches. To convert to SI units use
1 in. = 25.4 mm)

- NOTE 5:**
1. INTERPRET DRAWING AS PER ANSI Y14.5-1973.
 2. 64 FINISH EXCEPT AS NOTED; BREAK SHARP EDGES.
 3. WRAP IN CLOTH FOR PROTECTION FROM NICKS AND SCRATCHES.
 4. TOLERANCE: ±.005 EXCEPT AS NOTED

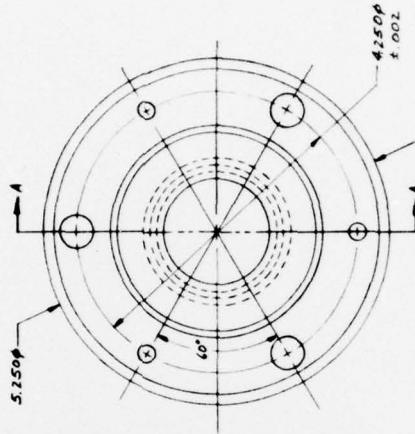
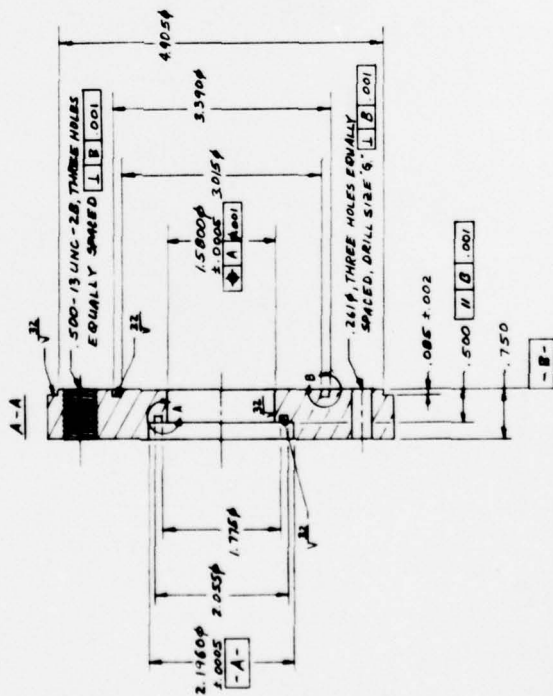
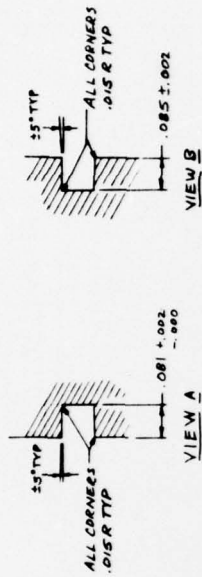

- REFERENCE**
1. INNER DRING - 2-234
 2. OUTER DRING - 2-244
 3. BARREL DRING - 2-134
 4. BARREL I.D. - 1.5743

DESIGNED BY	J.B.B.	DATE	9/57
CHECKED BY			
MATERIAL: S STEEL TYPE 316 SS			
SCALE: 1:1			
BARREL FLANGE PLATE		NAVAL WEAPONS LABORATORY BARBERS POINT, CALIF. 92011	
		57	

NOTES:

- 1 INTERPRET DRAWING AS PER ANCI Y14.5-1973.
- 2 .32 FINISH
- 3 WRAP IN CLOTH FOR PROTECTION FROM NICKS AND SCRATCHES.
- 4 BREAK SHARP EDGES .015 R TYP
- 5 TOLERANCE: ±.002 AND ±0.5°

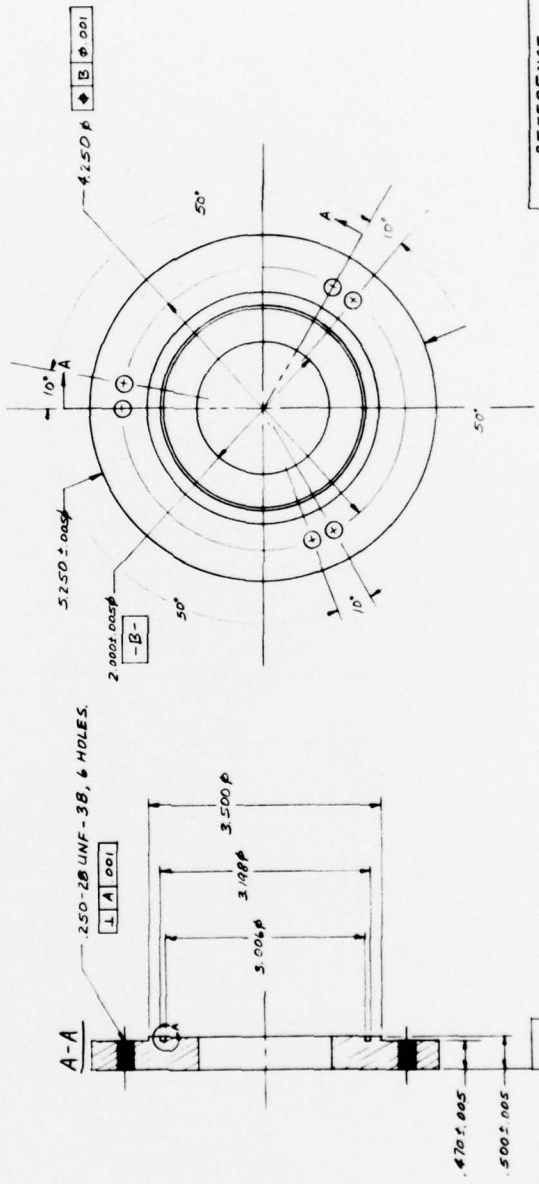
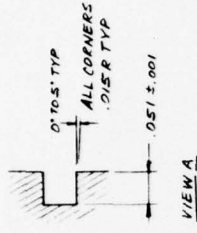

REFERENCE
1 TARGET DRING-2-041

DESIGNED	DATE	BY	SCALE	MATERIAL	FINISH	TOLERANCE
CHECKED	DATE	BY	SCALE			
TARGET-MOUNTING FLANGE PLATE				STEEL TYPE	1/1	
NAVAL WEAPONS LABORATORY						52
DANIELS WAREHOUSE BRANCH						

END-PLATE FOR FLANGE-
ADJUSTMENT DEVICE
SKETCH NO. 53

- NOTES:
 1. INTERPRET DRAWING AS PER ANSI Y14.5-1973.
 2. MATERIAL: STAINLESS STEEL TYPE 316 OR 304.
 3. 32 FINISH ALL OVER.

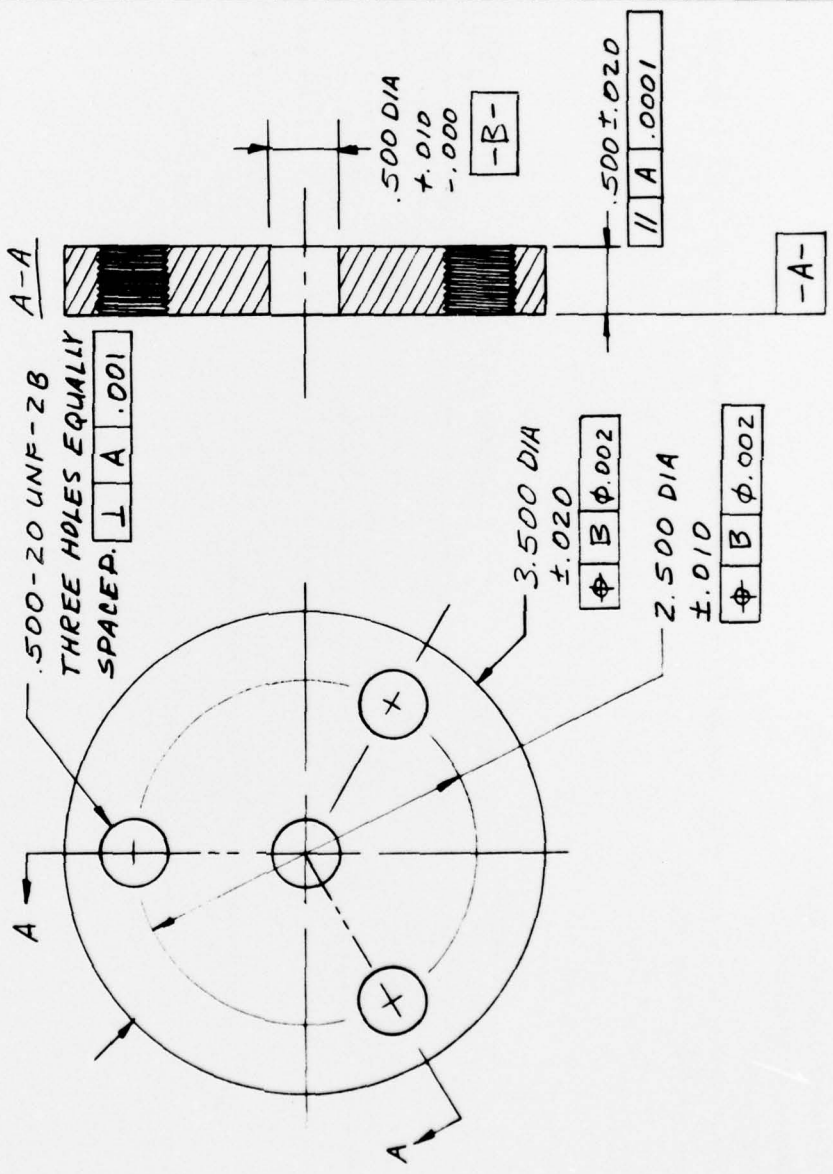

NOTES:

1. INTERPRET DRAWING AS PER ANSI Y14.5-1973.
2. BREAK SHARP EDGES.
3. 32 FINISH
4. THESE ARE GAUGING SURFACES, PROVIDE WRAPPING TO PREVENT NICKS AND SCRATCHES, PROVIDE AT LEAST 4" PACKING ON ALL SIDES PRIOR SHIPPING.

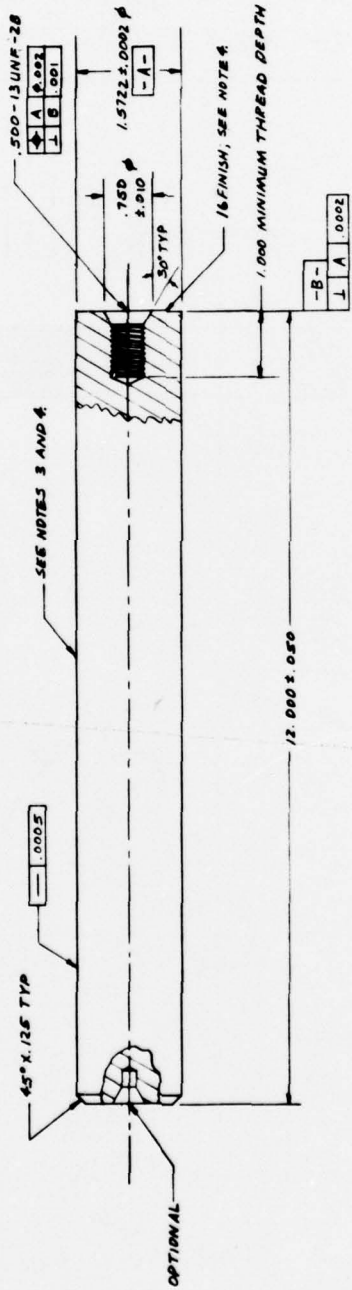

APPROVED	DATE	REVISION	BY	REASON
		1		
		2		
		3		
		4		
		5		
		6		
		7		
		8		
		9		
		10		
		11		
		12		
		13		
		14		
		15		
		16		
		17		
		18		
		19		
		20		
		21		
		22		
		23		
		24		
		25		
		26		
		27		
		28		
		29		
		30		
		31		
		32		
		33		
		34		
		35		
		36		
		37		
		38		
		39		
		40		
		41		
		42		
		43		
		44		
		45		
		46		
		47		
		48		
		49		
		50		
		51		
		52		
		53		
		54		
		55		
		56		
		57		
		58		
		59		
		60		
		61		
		62		
		63		
		64		
		65		
		66		
		67		
		68		
		69		
		70		
		71		
		72		
		73		
		74		
		75		
		76		
		77		
		78		
		79		
		80		
		81		
		82		
		83		
		84		
		85		
		86		
		87		
		88		
		89		
		90		
		91		
		92		
		93		
		94		
		95		
		96		
		97		
		98		
		99		
		100		

SHAFT FOR
FLANGE - ADJUSTMENT
DEVICE

MAVIA
UNIVERSITY
MADISON, WISCONSIN 53706

DISTRIBUTION

Defense Documentation Center
Cameron Station
Alexandria, VA 21314 (12)

Defense Printing Service
Washington Navy Yard
Washington, DC 20374

Naval Publications and Printing Service
NDW
Washington, DC 20390

Library of Congress
Washington, DC 20540
ATTN: Gift and Exchange Division (4)

Commander
Naval Sea Systems Command
Washington, DC 20360
ATTN: SEA-0333 (W. W. Blaine)
SEA-0333 (R. A. Bailey)

Commander
Naval Weapons Center
China Lake, CA 93555
ATTN: J. Pearson
Technical Library (2)

Director
Army Ballistics Research Laboratory
Terminal Ballistics Laboratory
Aberdeen Proving Ground, MD 20015
ATTN: G. E. Hauver
W. S. de Rosset

Commander
Army Materials and Mechanics Research Center
Watertown, MA 02172
ATTN: D. T. Dandekar

Los Alamos Scientific Laboratory
Los Alamos, NM 87544
ATTN: J. Wackerle
J. Morgan
R. Morales
J. M. Holt
Technical Library (2)

DISTRIBUTION (Continued)

Sandia Laboratories
Albuquerque, NM 87115
ATTN: R. A. Graham
P. C. Lysne

Lawrence Livermore Laboratory
University of California
Livermore, CA 94550
ATTN: D. L. Banner

Shock Dynamics Laboratory
Washington State University
Pullman, WA 99163
ATTN: Prof. G. E. Duvall
Prof. G. R. Fowles

Stanford Research Institute
Poulter Laboratory
333 Ravenswood Avenue
Menlo Park, CA 94025
ATTN: D. Curran
A. Bartlett

Local

CC	
CD	
DC	
DD	
DF	
DF-12 (Berger)	
DG	
DG-10	
DG-13	
DG-20	DX-40
DG-30	DX-43 (Sullivan)
DG-40	WR
DG-50	WR-02
DG-51	WR-04
DG-52	WR-10
DG-52 (Mock) (2)	WR-13
DG-52 (Holt) (2)	WR-13 (Forbes)
DG-52 (Wishard)	WR-13 (Edwards)
DG-53	WR-13 (Erkman)
DG-53 (Wenborne)	WR-13 (Coleburn)
DG-55	WR-30
DX-21	WR-303
DX-222 (6)	