

AD-A038 106

MCDONNELL DOUGLAS ASTRONAUTICS CO-WEST HUNTINGTON BEA--ETC F/G 13/13
RESEARCH STUDY OF EJECTA IMPACT PARAMETERS.(U)
DEC 73

UNCLASSIFIED

MDC-G4808

WES-CR-N-73-2

DACA39-72-C-0015
NL

1 of 1
ADA038106

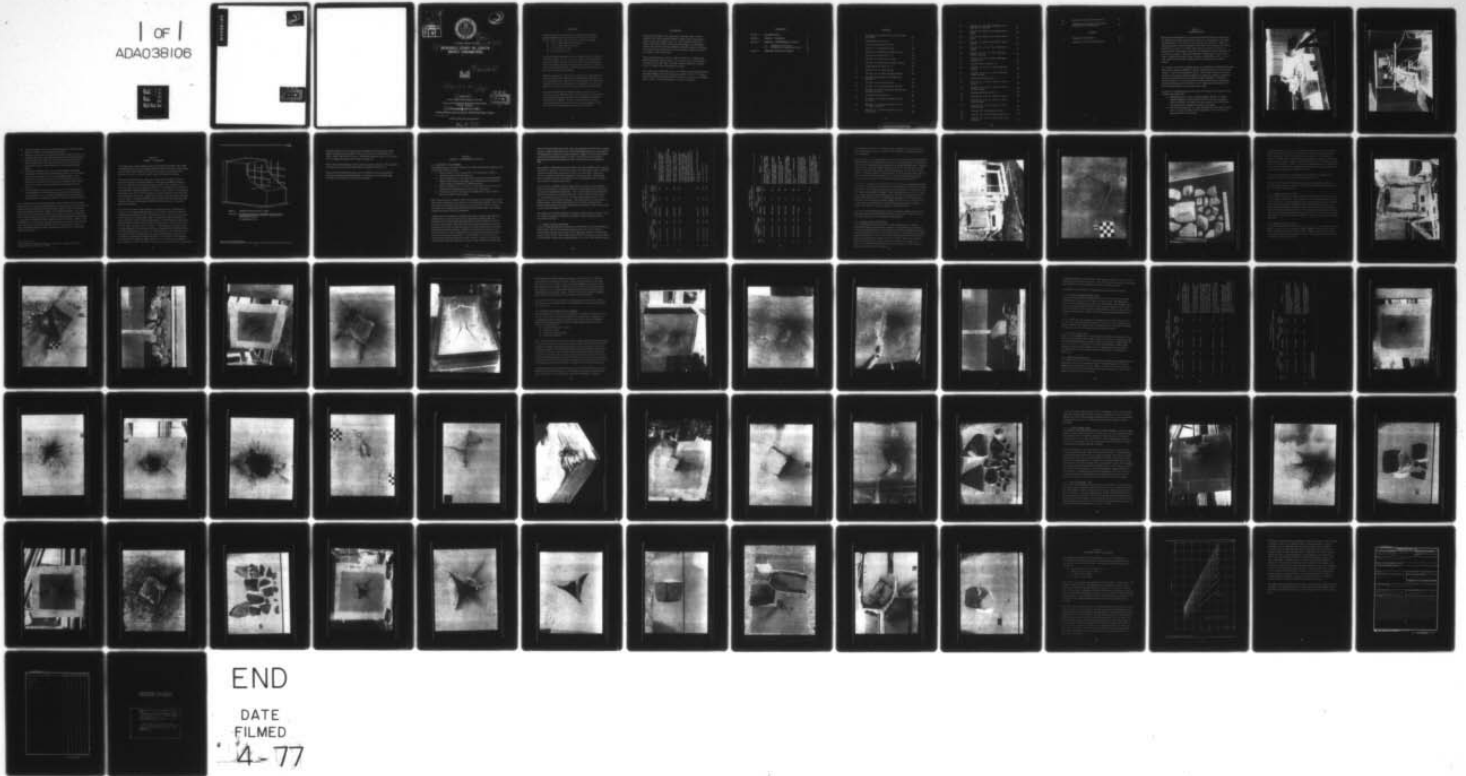

ADA 038106

2
NW

DDC
RECEIVED
APR 5 1977
D

White Section	<input checked="" type="checkbox"/>
Self Section	<input type="checkbox"/>
...	<input type="checkbox"/>
UNIVERSITY/AVAILABILITY CODES	
D-32. ALL OR SPECIAL	
A	

2



18 WES

CONTRACT REPORT N-73-2

19 CR-N-73-2

6 **RESEARCH STUDY OF EJECTA IMPACT PARAMETERS.**

14 MDC-G4848



9 Final rept. 12 69p.

11 December 1973

Sponsored by Office, Chief of Engineers, U. S. Army

Conducted for U. S. Army Engineer Waterways Experiment Station
Vicksburg, Mississippi

DDC
RECEIVED
APR 5 1977
D

15 Under Contract No. DACA39-72-C-0015

By McDonnell Douglas Astronautics Company - West Huntington Beach, California

ARMY-MRC VICKSBURG, MISS.

APPROVED FOR PUBLIC RELEASE: DISTRIBUTION UNLIMITED

1473
404 770

AB

ABSTRACT

Impact tests were performed to investigate survivability of proposed BMD structural materials to fallout debris from a nuclear surface burst. The materials evaluated included:

- A. 1.0-in. thick 6061-T651 aluminum
- B. 2.5-in. thick epoxy fiber glass
- C. 0.5-in. thick T-1 steel
- D. 24-in. thick concrete

A specially designed powder gun was utilized to project sandstone missiles weighing 10-, 25-, and 50-lb each at the specified targets. The impact velocity for the 10- and 25-lb projectiles was nominally 300 fps and the 50-lb projectiles impacted at velocities near, but exceeding, 200 fps. The damage incurred in the targets as result of impact was negligible.

Thinner plates (0.375- and 0.25-in. thick) of T-1 steel and mild steel were impacted to determine the penetrating capability of a 50-lb sandstone cube. Both 0.25-in. thick plates were penetrated while the 0.375-in. thick plates were only dented. A fiber glass panel 0.94-in. thick was also penetrated by the 50-lb projectile.

These tests indicate that sandstone debris in these sizes is a minimal threat to BMD structures although stronger material such as granite has shown considerably more penetration capability in previous tests at MDAC. It is also apparent that previously established predictive data for granite would not apply for materials with less strength than granite such as sandstone.

FOREWORD

The work described in this report was performed under contract DACA39-72-C-0015, Research Study of Ejecta Impact Parameters, dated 30 June 1972, between the U. S. Army Engineer Waterways Experiment Station (WES), Vicksburg, Mississippi, and McDonnell Douglas Astronautics Company (MDAC), Huntington Beach, California. The research was sponsored by the Directorate of Military Construction, Office, Chief of Engineers.

This report describes a series of ejecta impact tests conducted by MDAC using their ejecta cannon. The research was conducted under the supervision of Mr. Glen L. Roark, Program Manager, with Mr. Bruce L. Cooper as the Principal Investigator.

The contract was monitored by Mr. J. W. Meyer of the Weapons Effects Laboratory (WEL) under the general supervision of Mr. L. F. Ingram, Chief of the Phenomenology and Effects Division, and Mr. W. J. Flathau, Chief of WEL. Contracting Officer was BG E. D. Peixotto.

CONTENTS

Section 1	INTRODUCTION	1
Section 2	PHASE I - PLANNING	5
Section 3	PHASE II - EXPERIMENTAL STUDY	9
	3.1 Diagnostic Test Series	9
	3.2 Parameter-Variation Test Series	24
Section 4	SUMMARY AND CONCLUSIONS	57

FIGURES

1	Rock Mortar-Front View with 10-lb Granite Projectile	2
2	Rock Mortar—Rear View	3
3	Concrete Target Specifications	6
4	Test No. 12, Aluminum Target	14
5	Test No. 12, Aluminum Target—Closeup	15
6	Fragments From Test No. 12	16
7	Test No. 13, Fiber Glass Target	18
8	Test No. 13, Fiber Glass Target—Closeup	19
9	Fragments From Test No. 13	20
10	Test No. 14, T-1 Steel Target	21
11	Test No. 14, T-1 Steel Target—Closeup	22
12	Concrete Target Form and Reinforcing Structure	23
13	Test No. 15, Concrete Target	25
14	Test No. 15, Concrete Target—Closeup	26
15	Test No. 15, Concrete Target—Closeup with Residue Removed	27
16	Fragments from Test No. 15	28
17	Test No. 16, Colorado Sandstone versus T-1 Steel	32
18	Test No. 16, Colorado Sandstone versus T-1 Steel—Closeup	33
19	Test No. 17, Colorado Sandstone versus Fiber Glass	34

20	Test No. 17, Colorado Sandstone versus Fiber Glass—Closeup	35
21	Test No. 8, Granite versus Fiber Glass— Front	36
22	Test No. 8, Granite versus Fiber Glass— Back	37
23	Test No. 8, Granite versus Fiber Glass— Section	38
24	Test No. 18, 0.25-in. Thick Mild Steel Target	39
25	Test No. 18, 0.25-in. Thick Mild Steel Target—Closeup	40
26	Test No. 18, 0.25-in. Thick Mild Steel Target—Back	41
27	Fragment From Test No. 18	42
28	Test No. 19, 0.375-in. Thick Mild Steel Target	44
29	Test No. 19, 0.375-in. Thick Mild Steel Target—Closeup	45
30	Fragments From Test No. 19	46
31	Test No. 21, 0.375-in. Thick T-1 Steel Target	47
32	Test No. 21, 0.375-in. Thick T-1 Steel Target—Closeup	48
33	Fragments From Test No. 21	49
34	Test No. 22, 0.25-in. Thick T-1 Steel	50
35	Test No. 22, 0.25-in. Thick T-1 Steel, Front Closeup	51
36	Test No. 22, 0.25-in. Thick T-1 Steel, Back Closeup	52
37	Test No. 22, Projectile After Test	53
38	Test No. 20, 0.94-in. Thick Fiber Glass	54
39	Test No. 20, 0.94-in. Thick Fiber Glass— Closeup	55

40	Test No. 20, Projectile After Test	56
41	Penetration versus Impact Velocity for Granite Rocks on Steel Plates	58

TABLES

1	Diagnostic Test Results	11
2	Parameter-Variation Test Results	30

Section 1
INTRODUCTION

During recent ABM studies it became apparent that prediction of damage to the phased array radar and associated structure, resulting from the impact of fallout debris from a nuclear surface burst, was uncertain. There are different theories of rock distribution and fallout, but regardless of the rock distribution, given a rock and an impact angle and velocity, there is no empirical data or theoretical approach that adequately predicts damage with a feeling of certainty. Effects of interaction of parameters such as rock shape, composition, impact angle, breakup, target stiffness, etc., are not well understood at this time, especially in this low projectile velocity regime.

As a result, an in-house research project was undertaken by McDonnell Douglas Astronautics Company (MDAC) in which a propellant powered rock projector (Figures 1 and 2) was designed and built. This cannon is capable of projecting rocks of any shape against targets at velocities simulating the maximum terminal velocities of rocks free-falling in the atmosphere. During this research project, 5- and 10-lb granite cylinders were fired at steel plates varying in thickness from 0.188 in. to 2.0 in. High-speed photography was used to provide details of rock-target interaction.

A number of interesting effects were observed during this test period, some of which are listed below:

- A. Although the rock velocity is approximately 300 fps, the initial impact sidespray is a fine dust cloud with a velocity of approximately 1,400 fps. This dust cloud spray moves out laterally from the impact point and hugs the surface of the plate.
- B. The rocks striking the 2-in. plate fragment into sharp pieces which have an average fragment velocity (parallel to the steel plate) of approximately 150 to 200 fps.



Figure 1. Rock Mortar - Front View with 10-lb Granite Projectile

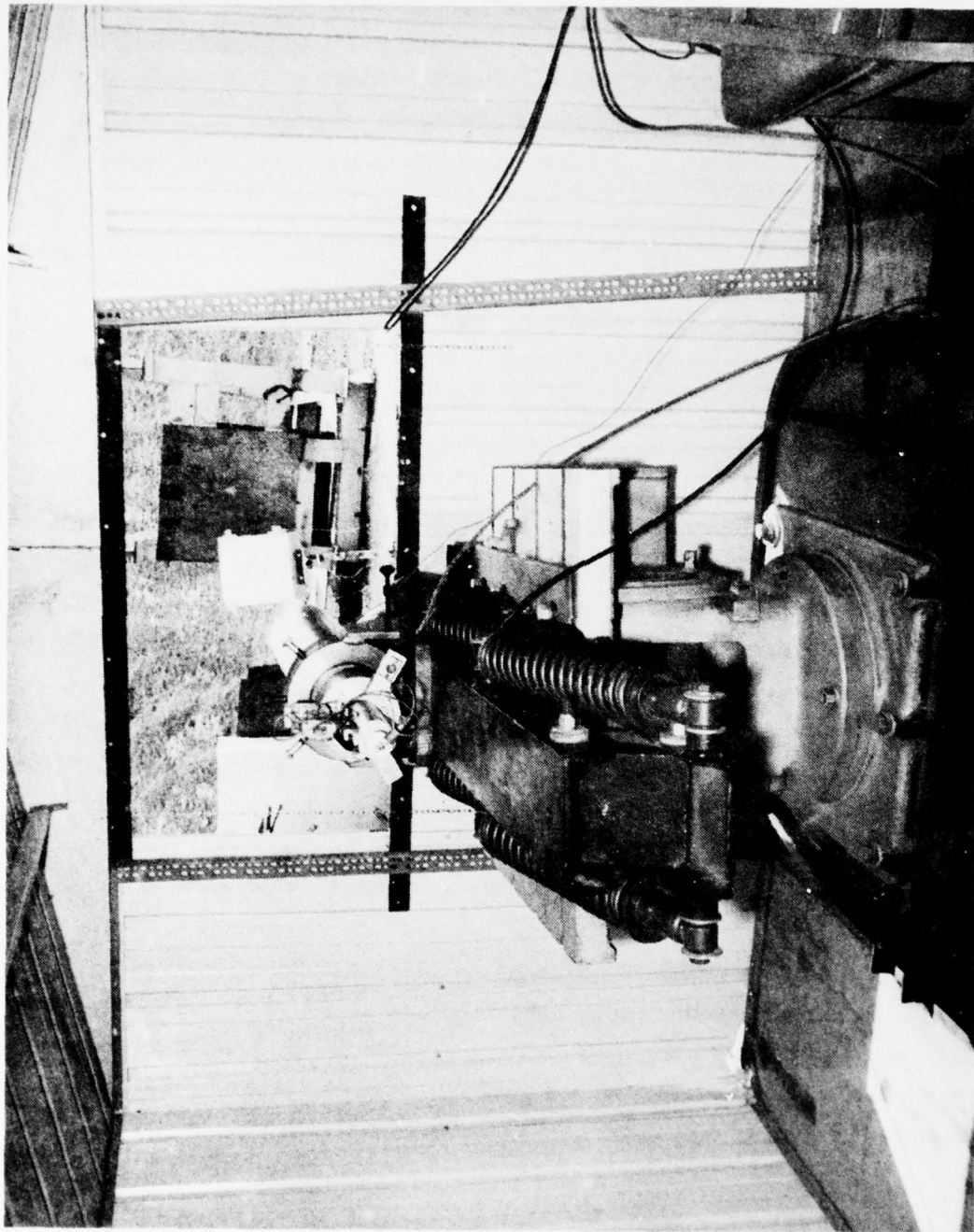

Figure 2. Rock Mortar - Rear View

- C. The rock fragments do not rebound at angles from the steel plate but follow a path almost parallel to the plate.
- D. There is a correlation of fragment sizes and initial rock size; i. e., the larger the rock, the larger the size of its principal fragments.
- E. There is a geometry effect on impact damage and penetration of thinner plates. Rock-cylinders hitting on an edge cut through a plate while similar rocks hitting end-on only dented the same plate.
- F. On the thinner plates, the rocks were essentially undamaged regardless of whether they penetrated the target or were stopped by the target. Except for minor edge chipping, there was no fracture or cracking of the rock. This indicates that, at some thickness or compliance, there will be a transition region where the rock will break up and the high velocity sidespray will be formed.
- G. Even though the rock velocity is very low, the limited test data corresponded very well with the empirically derived equation for small particles; i. e., projectile diameter much greater than the plate thickness, striking thin plates at extremely high velocities.*

These experiments demonstrated that there was a definite need for further experiments to increase the understanding of the low-speed impact phenomena, thereby precipitating this experimental study with the Corps of Engineers, Waterways Experiment Station (WES), Vicksburg, Mississippi. This study was performed in two phases. Phase I was a study in which a detailed planning of impact experiments was coordinated with representatives of the Office of the Corps of Engineers (OCE), Huntsville Engineer Division (HND), WES, and MDAC. Phase II was the experimental phase of the study where the tests were conducted in accordance with the test plan as formulated in Phase I. This experimental effort included a diagnostic test series and a parameter-variation test series.

*NASA SP-8042, Meteoroid Damage Assessment, NASA Space Vehicle Design Criteria (Structure), 1970.

Section 2
PHASE I - PLANNING

The first portion of this study involved a joint effort with WES, OCE, HND, and MDAC personnel in developing a detailed plan for the impact experiments. In this effort, determination was made of such items as projectile size, geometry, material, velocity, impact angle, and target description.

The primary objective of the study was to determine the effects of ejecta fragment impacts on advanced ballistic missile defense (BMD) structural materials; therefore, four typical target materials were selected: (1) T-1 steel, (2) epoxy fiber glass (Synthane GEC 500, Type GEE, MIL-P-18177C), (3) reinforced concrete as specified in Figure 3, and (4) 6051-T651 aluminum. All targets were 4.0- by 4.0-foot square, secured around all four sides such that local failure may occur, rather than flexural or bending failure along the mounted edges. The target thickness for the initial tests was selected as the minimum thickness for the specific BMD structural material or potential structural material.

The projectiles used for this study were natural materials with properties similar to rock types located at actual missile sites. Properties of the test materials are available at WES. The projectiles were cubical or near cubes, so that impacts on a sharp edge might be obtained, thereby simulating the worst case with respect to target vulnerability. Consideration was also given to firing blunt-nose projectiles as part of the parameter-variation test series, but this later proved to be unnecessary. The principal projectile weight was approximately 50 lb, however, during the diagnostic tests of the aluminum and fiber glass targets, 10-lb and 25-lb projectiles were used initially on the assumption that the smaller projectile might penetrate these materials. If they didn't, the projectile weight would then be increased until the maximum projectile-weight capability (approximately 50 lb at 350 fps) was reached or target failure occurred. The impact velocities selected were to be the calculated

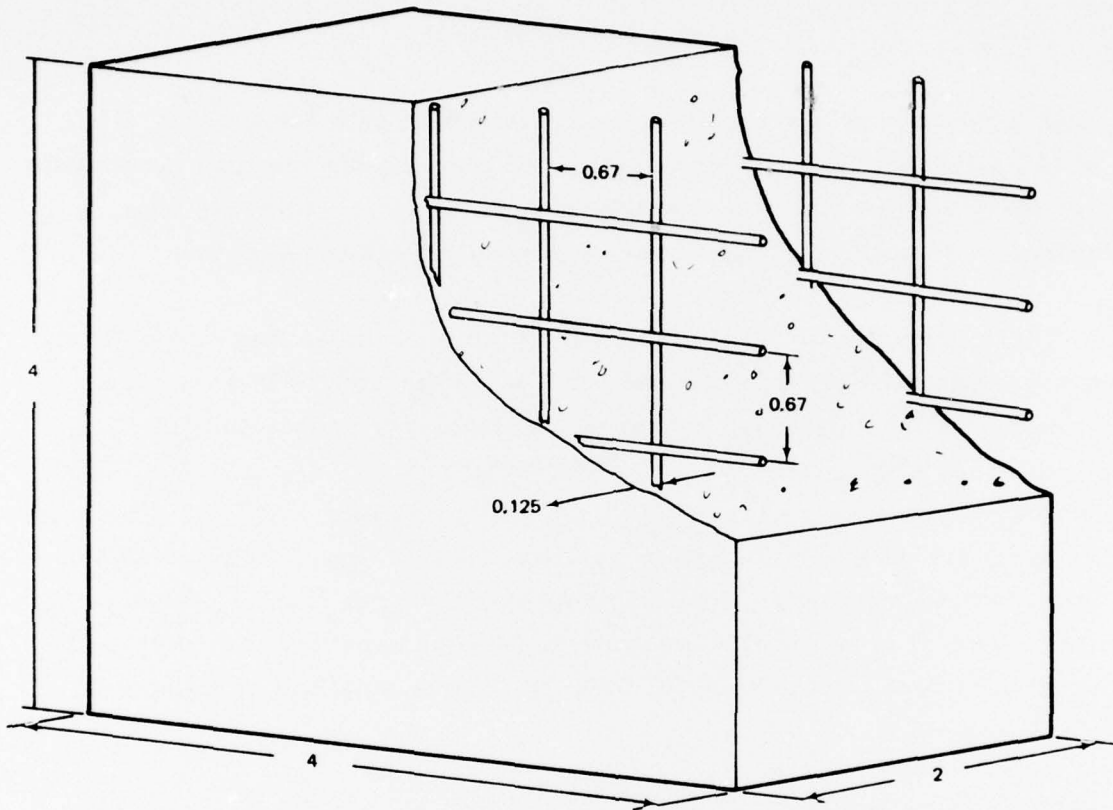

CONCRETE: COMPRESSIVE STRENGTH AT 28 DAYS - 4,000 PSI

REINFORCING: NO. 8 BARS (1 INCH DIAMETER, 2.67 POUNDS PER LINEAR FOOT) SPACED 8 INCHES ON CENTER EACH WAY IN EACH FACE. MINIMUM COVER ON REINFORCING IS 1.5 INCHES.

ALL DIMENSIONS ARE IN FEET

Figure 3. Concrete Target Specifications

terminal velocity for free falling rocks ejected by a nuclear surface burst. These velocities are nominally 275 fps for 10-lb rocks, 325 fps for 25-lb rocks, and 375 fps for 50-lb rocks. During the diagnostic tests, it was necessary to modify this plan as discussed in Section 3. 1.

The results of the diagnostic test series were used to determine the parameter-variation test series. These tests will be discussed in Section 3.2.

Data collection during these tests were to include velocity measurements obtained from high-speed photography, visual inspection and photographs of targets, and collection of projectile fragments.

Section 3
PHASE II - EXPERIMENTAL STUDY

3.1 DIAGNOSTIC TEST SERIES

The diagnostic test series was designed to answer the following questions with a minimum number of trials:

- A. The resistance of 1.0-in. thick 6061-T651 aluminum to edge-on impacts normal to the target surface.
- B. The survivability of 2.5-in. thick fiber glass to projectiles striking edge-on and normal to the target, thus determining the suitability of fiber glass as a material for BMD structures.
- C. The survivability of 0.5-in. thick T-1 steel to the largest projectile weight (50 lb) striking edge-on and normal to the plate.
- D. The effects of the 50-lb projectile striking edge-on and normal to the 24-in. thick concrete target.

All of the test plates, except for the concrete target, were clamped to a large steel frame made from 8-in. I-beam to ensure maximum rigidity. The I-beam framed the test sample on the back side, leaving a 30.0- x 30.0-in. square free space on the target that would allow projectile penetration of the target without interference from the framework.

Velocity data were obtained by utilizing high-speed cameras (approximately 2,500 frames/second) located normal to the projectile flight path. Two stanchions were located along the flight path to measure distance travelled in a given time period. These data were backed up by utilizing an electrical break circuit to start and stop an electronic counter as the projectile passed through pre-positioned stations. Pressure-time histories in the gun were also recorded to monitor repeatability and to ensure that internal pressures were not exceeding gun limitations. Some differences were noted in the velocity measurements between the three systems, but they were generally less than 10 percent. The velocities indicated in the presented test data were

obtained from the high-speed film, since this appeared to be the more reliable method. A high-speed camera was also located approximately 10 degrees off the flight path to observe the target response to impact, as well as to observe projectile breakup and the spray velocity. This camera was operated at approximately 6,000 frames/second. All of the test films are available at WES.

The sandstone projectiles utilized for these tests were obtained from a quarry in Ash Fork, Arizona. The first projectile materials obtained were sandstone slabs that could only be made into 10- and 25-lb projectiles. These projectiles resembled rough parallelepipeds rather than cubes, although they were acceptable for test. The stones for 50-lb projectiles came at a later date and were cut into perfect cubes.

Previous tests at MDAC had been with granite projectiles and no difficulty had been encountered in launching; however, the sandstone material does not have the strength inherent in granite. This caused problems in attempting to launch the sandstone projectiles; therefore, many of the early shots were not considered good tests. In order to keep the projectiles intact, it was necessary to lower the firing velocity. This modification was acceptable to WES personnel, since their observation from previous cratering tests indicated that fallout velocity was somewhere near 200 fps. This was selected as the minimum impact velocity.

The results of all of the diagnostic test firings are presented in Table 1. Only the firings considered as producing acceptable impact data points will be discussed in this text.

3.1.1 Impact Tests on Aluminum

Test No. 3 was the first test on aluminum in which the projectile impacted the target intact. The 10-lb projectile measured 4.0 x 4.8 x 7.0 in. and was launched with the long axis parallel to the flight path. Impact velocity of the projectile was 298 fps. Upon impact the projectile broke up into several small pieces with the largest pieces approximating 2-in. cubes. The breakup velocity

Table 1 (Page 1 of 2)
DIAGNOSTIC TEST RESULTS

Test No.	Projectile		Target		Impact Velocity (fps)	Results
	Dimensions (in.)	Weight (lb.)	Material	Thickness (in.)		
1	3.8 x 5.0 x 6.5	10.0	Aluminum	1.0	344	Projectile broke up into multiple fragments during launch with no resultant damage to the target.
2	5.3 x 5.3 x 6.0	10.0	Aluminum	1.0	261	Projectile broke up during launch. One large piece hit low on the target but no damage was apparent.
3	4.0 x 4.8 x 7.0	10.0	Aluminum	1.0	298	Good launch with no breakup. No noticeable damage to the target.
4	4.5 x 6.5 x 9.0	25.0	Aluminum	1.0	327	A small portion of the projectile broke off during launch but the major piece appeared to weigh greater than 20 lb. The smaller piece impacted first with the larger piece following. A slight bow was detected in the plate. The depth was approximately 0.13 in. in 48.0 in.
9	8.5 x 8.5 x 8.5	48.0	Aluminum	1.0	303	Projectile shattered during launch - no damage.
10	8.5 x 8.5 x 8.5	49.0	Aluminum	1.0	272	Same as Test No. 9.
11	8.5 x 8.5 x 8.5	49.0	Aluminum	1.0	204	Same as Test No. 9.

Table 1 (Page 2 of 2)
 DIAGNOSTIC TEST RESULTS

Test No.	Projectile		Target		Impact Velocity (fps)	Results
	Dimensions (in.)	Weight (lb.)	Material	Thickness (in.)		
12	8.5 x 8.5 x 8.5	50.0	Aluminum	1.0	216	Good launch. Broke into several large pieces upon impact. Target was dished 1.5 in. in 48.0 in. and 0.5 in. in 15.0 in.
5	4.8 x 5.3 x 6.0	10.0	Fiber glass	2.5	363	Broke up during launch. Largest piece weight approximately 5 lb. No damage to the target.
6	5.0 x 5.0 x 5.0	10.0	Fiber glass	2.5	280	Broke up during launch. No large pieces noted and no damage resulted in the target.
7	4.5 x 6.5 x 9.0	25.0	Fiber glass	2.5	281	Some apparent break up during launch. The largest piece weighed about 15 to 20 lb. No noticeable damage occurred.
13	8.5 x 8.5 x 8.5	50.0	Fiber glass	2.5	209	Good launch - no damage to the target.
14	8.5 x 8.5 x 8.5	48.0	T-1 Steel	0.5	216	Good launch; projectile broke into several pieces upon impact. No penetration or spalling occurred, although the plate was bowed to a depth of 1.0 in. in 48.0 in. and 0.5 in. in 15.0 in.
15	8.5 x 8.5 x 8.5	50.0	Concrete	24.0	225	Good launch; projectile broke into several pieces upon impact. A 10.0-in. long x 6.5-in. wide x 1.0-in. deep crater was formed. The damaged area did not reach the reinforcing bar.

or sidespray was from 300 to 400 fps. This consisted of very fine particles; the larger particles had considerably lower velocity. The aluminum target was undamaged.

For Test No. 4, a 25-lb projectile 4.5 x 6.5 x 9.0 in. was fired at the aluminum target similar to the method used in Test No. 3. A small portion of the projectile broke off during launch but, judging from the photographic data, it appears that the major particle weighed approximately 20 lb. The smaller piece hit slightly before the larger piece. Impact velocity was 327 fps, with a small particle sidespray velocity of about 200 fps. No local damage to the plate was detected but the plate was bowed 0.13 in. This was measured by placing a straight edge across the 48-in. plate and measuring total deflection.

Test No. 12 consisted of a 50-lb cube, 8.5 x 8.5 x 8.5 in., impacting the target at 216 fps. The projectile remained intact during launch but broke into several large pieces upon impacting the target. The largest piece weighed about 20 lb. The target incurred minor damage. Total plate deflection was 1.5 in., with a 0.5-in. deep dent noted at the impact point. The dent at the impact point was measured by placing a 15.0-in. straight edge diagonally across the square "footprint" and measuring maximum depth. As may be seen in Figures 4 and 5, the projectile impacted on a corner producing representative edge-on impact data. Figure 6 shows the larger residual fragments.

This test concluded the diagnostic tests for aluminum showing that the minimum thickness considered for this material could survive impacts of sandstone projectiles up to 50 lb without serious damage.

3.1.2 Impact Tests on Fiber Glass

Two 10-lb projectiles were fired at the fiber glass target, but neither maintained integrity during launch. Because of the difficulty of keeping the smaller projectiles intact, it was agreed upon by WES and MDAC personnel to proceed with the 25-lb test. This was Test No. 7, consisting of an irregular shaped projectile 4.5 x 6.5 x 9.0 in. fired with the longer axis along the projectile flight path with an impact velocity of 281 fps. Again, the sandstone broke up during launch, but the largest piece appeared to weigh from 15 to 20 lb. The resultant damage to the fiber glass consisted of minor surface pocks but was otherwise undamaged.

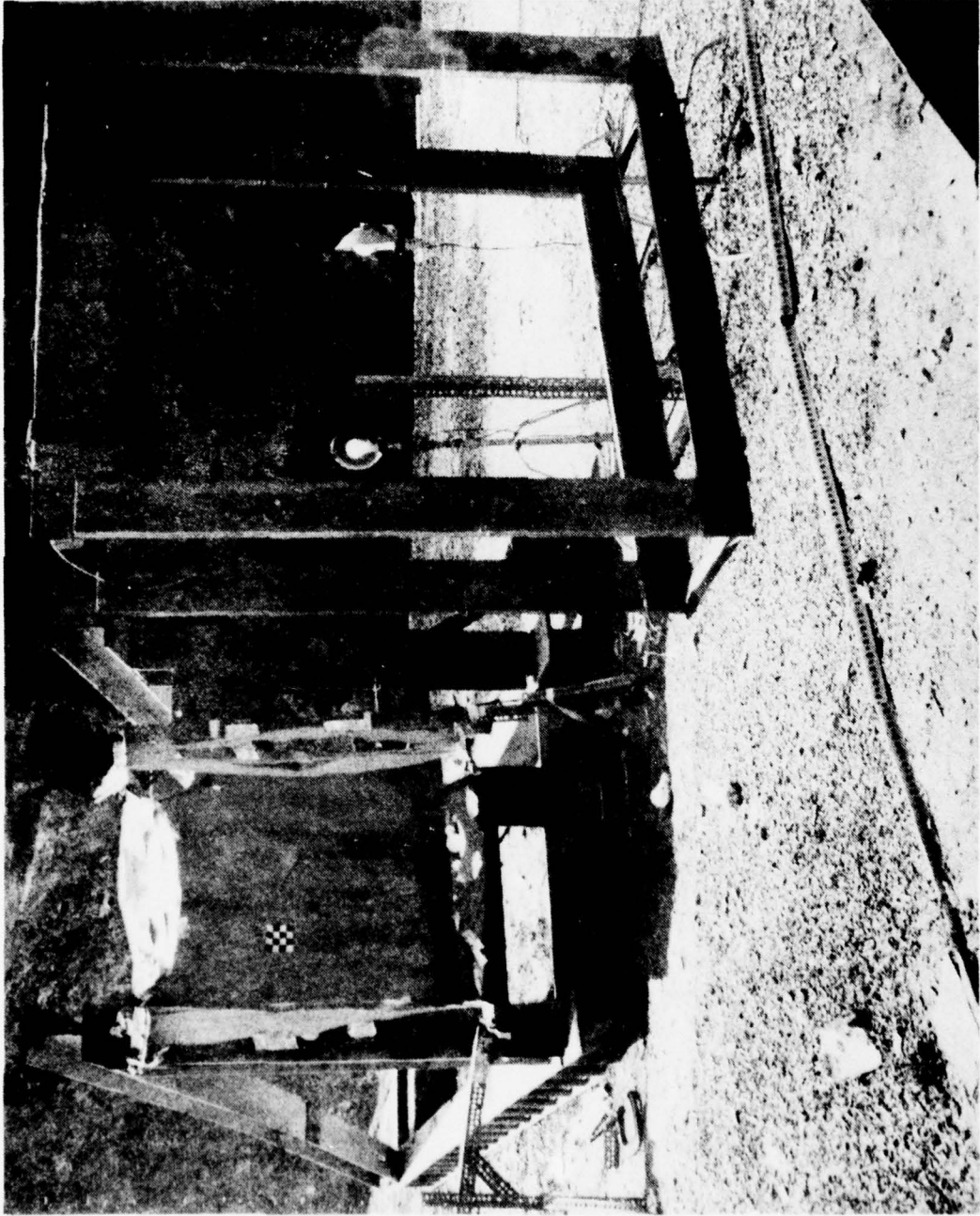

Figure 4. Test No. 12, Aluminum Target

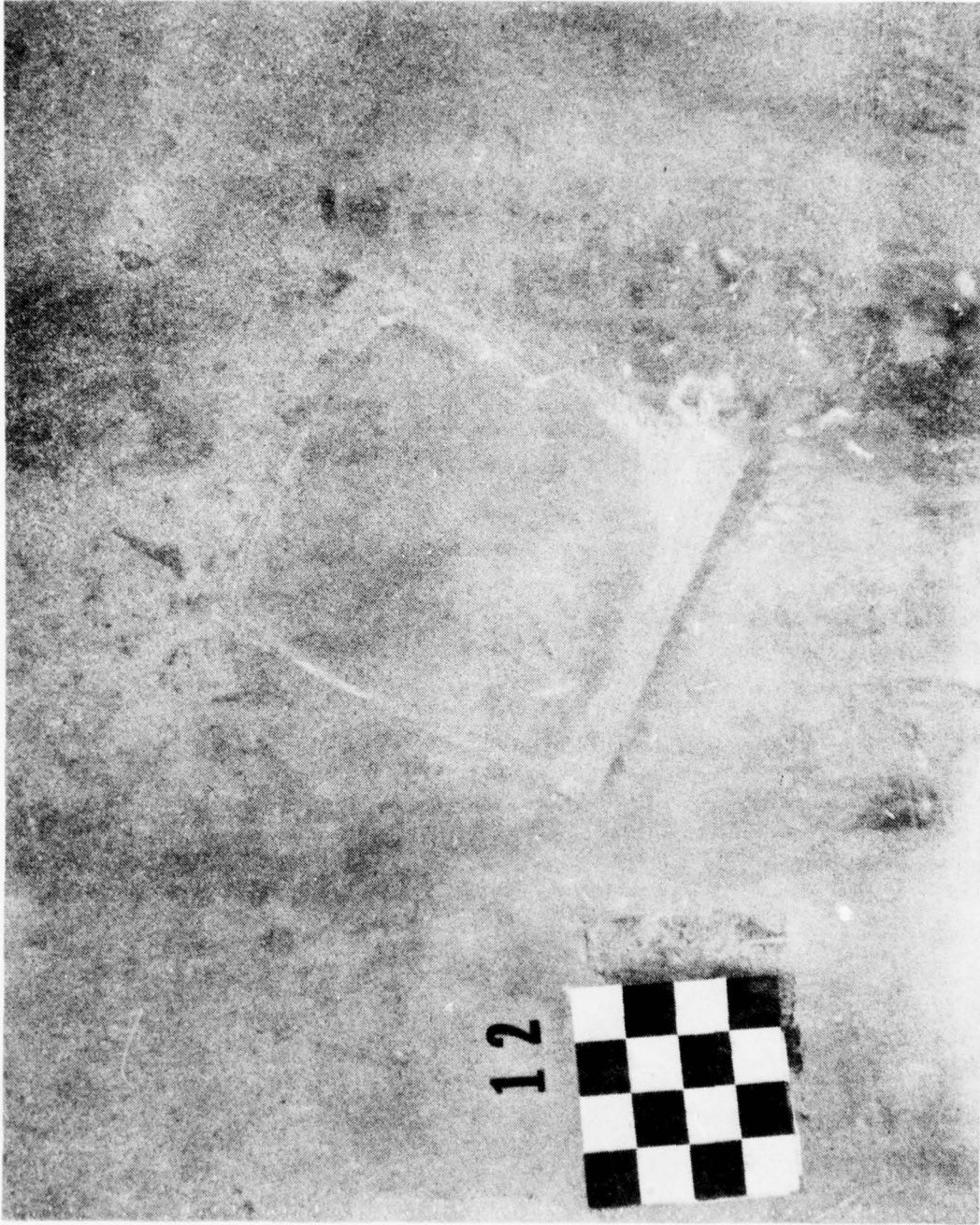

Figure 5. Test No. 12, Aluminum Target – Closeup

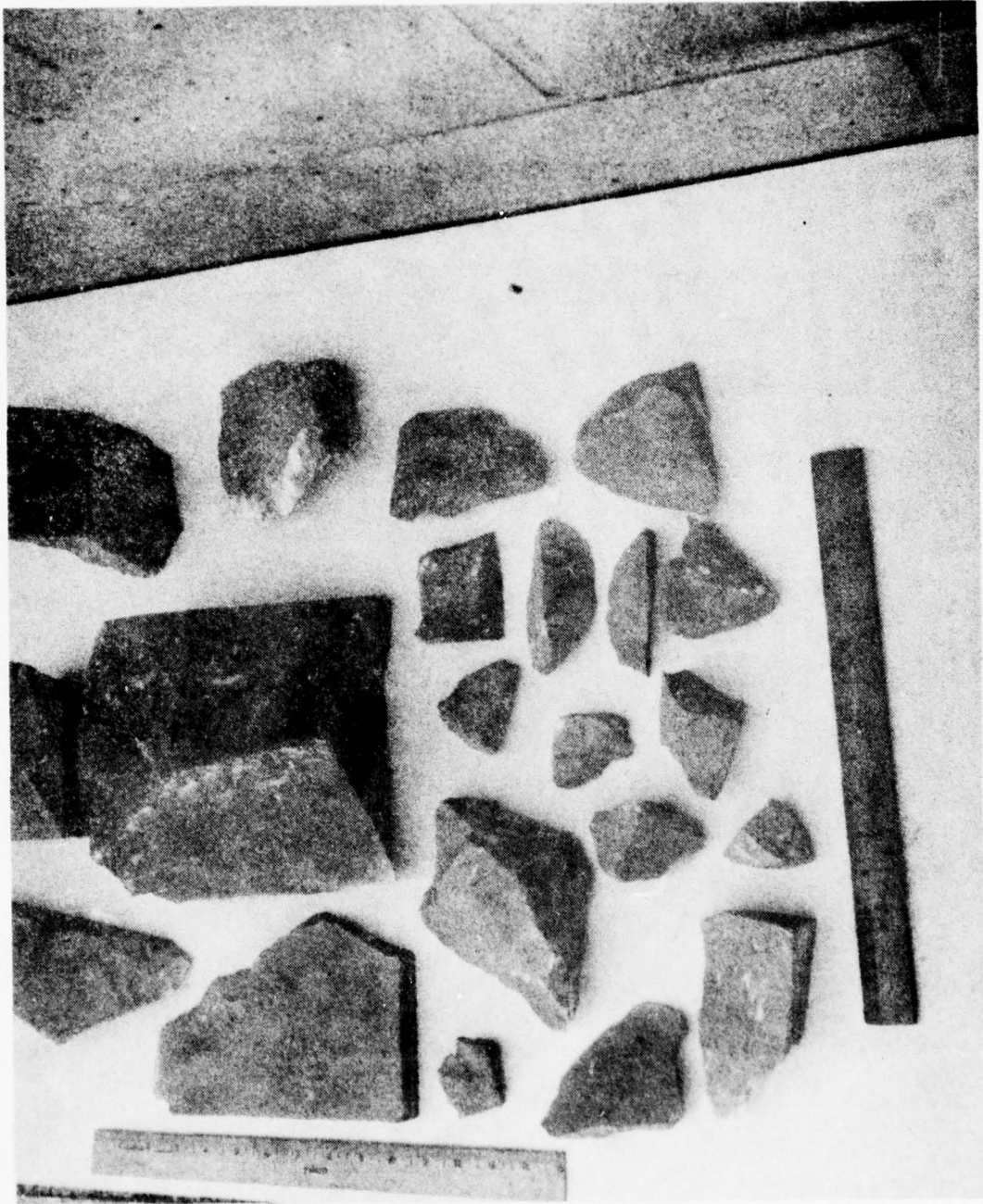

Figure 6. Fragments from Test No. 12

A 50-lb cube 8.5 x 8.5 x 8.5 in. was used for Test No. 13. This was launched such that the impact velocity was 209 fps. The projectile remained intact until impact where it broke into several large pieces, with a sidespray velocity of 300 to 400 fps. The target was not damaged. Figures 7 and 8 show the target after impact. Figure 8 reveals that the corner of the projectile hit first for a good edge-on impact. Lines in the photograph are not cracks in the fiber glass but "footprints" revealing how breakup occurred in the sandstone. The sandstone fragments are shown in Figure 9.

These tests also indicate the capability of this material to withstand the largest rock projectiles considered for this test series.

One other test was conducted during this series to evaluate the effects of granite versus sandstone. This was Test No. 8, which will be discussed with the parameter-variation tests.

3.1.3 Impact Tests on T-1 Steel

The purpose of Test No. 14 was to determine the survivability of 0.5-in. thick T-1 steel when impacted by a 50-lb projectile. The sandstone projectile was an 8.5 x 8.5 x 8.5-in. cube weighing 48.0 lb, with an impact velocity of 216 fps. The projectile remained intact during launch but broke into several large pieces upon impact with a sidespray velocity of 300 to 400 fps. The largest piece observed weighed less than 1 lb. The plate was not penetrated, nor did spalling occur; total permanent deflection was 1.0 in., with a 0.5-in. deep dent where the corner of the projectile impacted. Figures 10 and 11 show the plate after test.

3.1.4 Impact Tests on Concrete

Test No. 15 consisted of firing a 50-lb, 8.5 x 8.5 x 8.5-in. cube against a 24-in. thick concrete slab. The target was made by MDAC to specifications set by WES. A sample of the concrete was tested by WES and was found to have an unconfined compressive strength of 6,290 psi. Forms and reinforcing for this structure are shown in Figure 12.

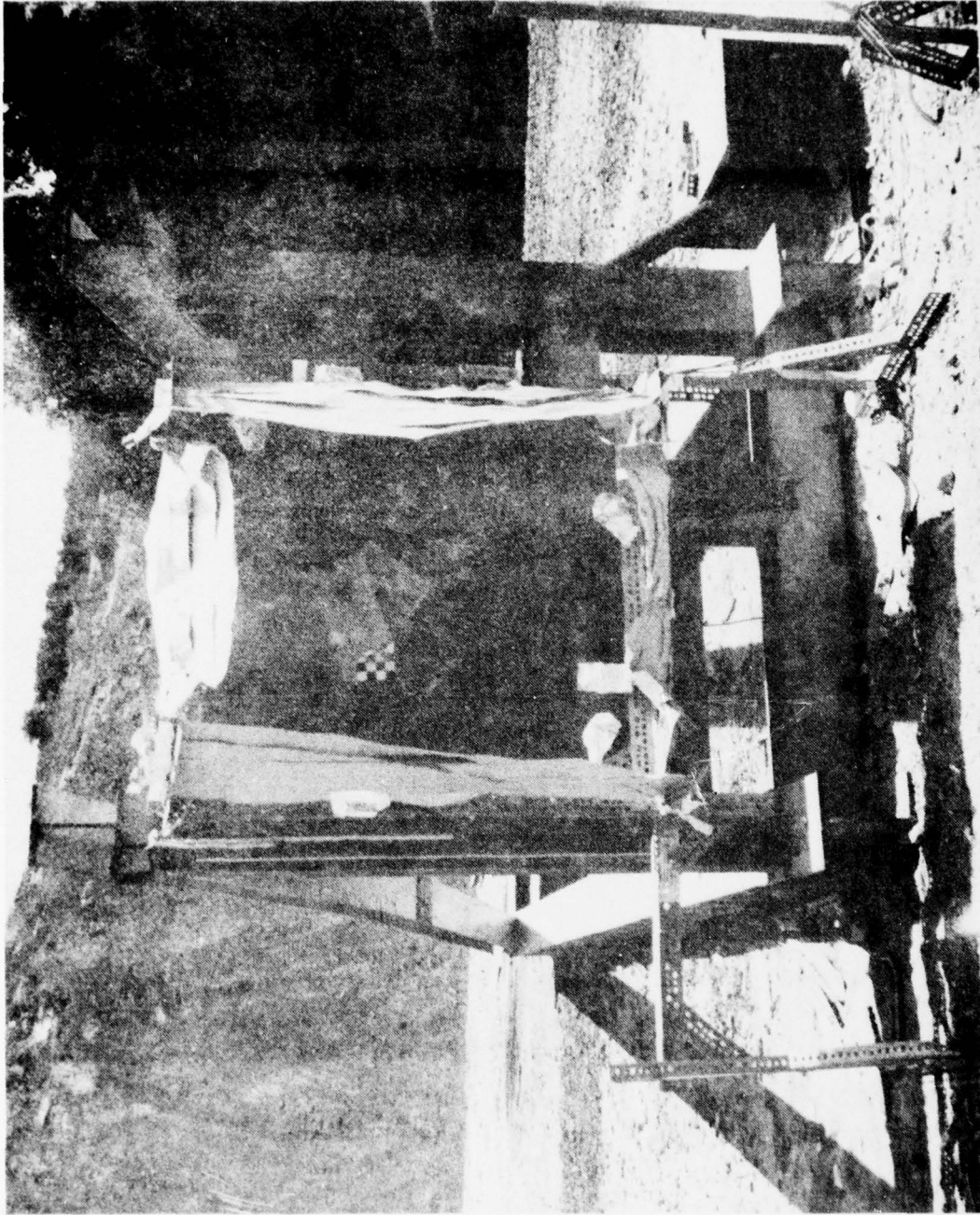

Figure 7. Test No. 13, Fiber Glass Target

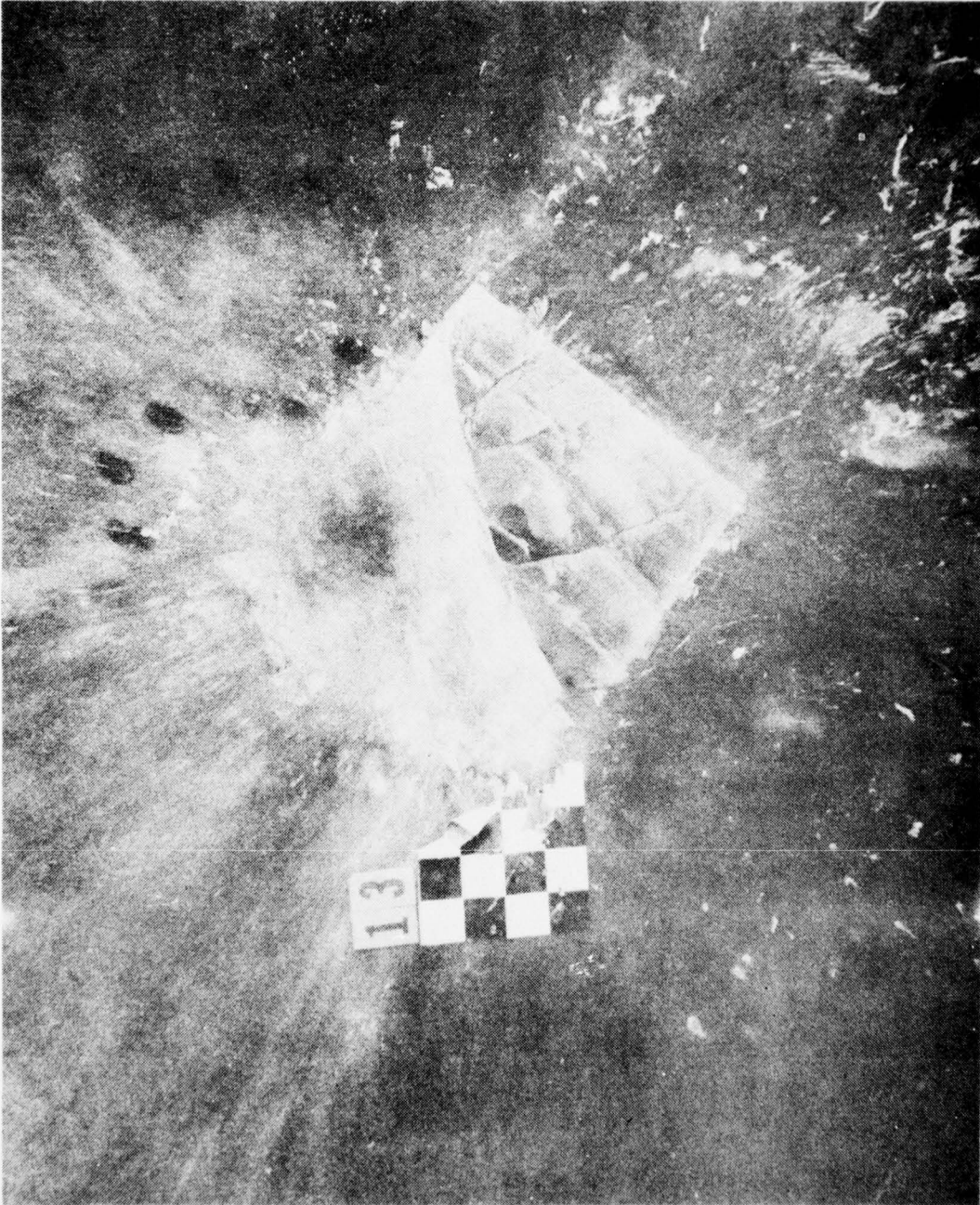

Figure 8. Test No. 13, Fiber Glass Target — Closeup

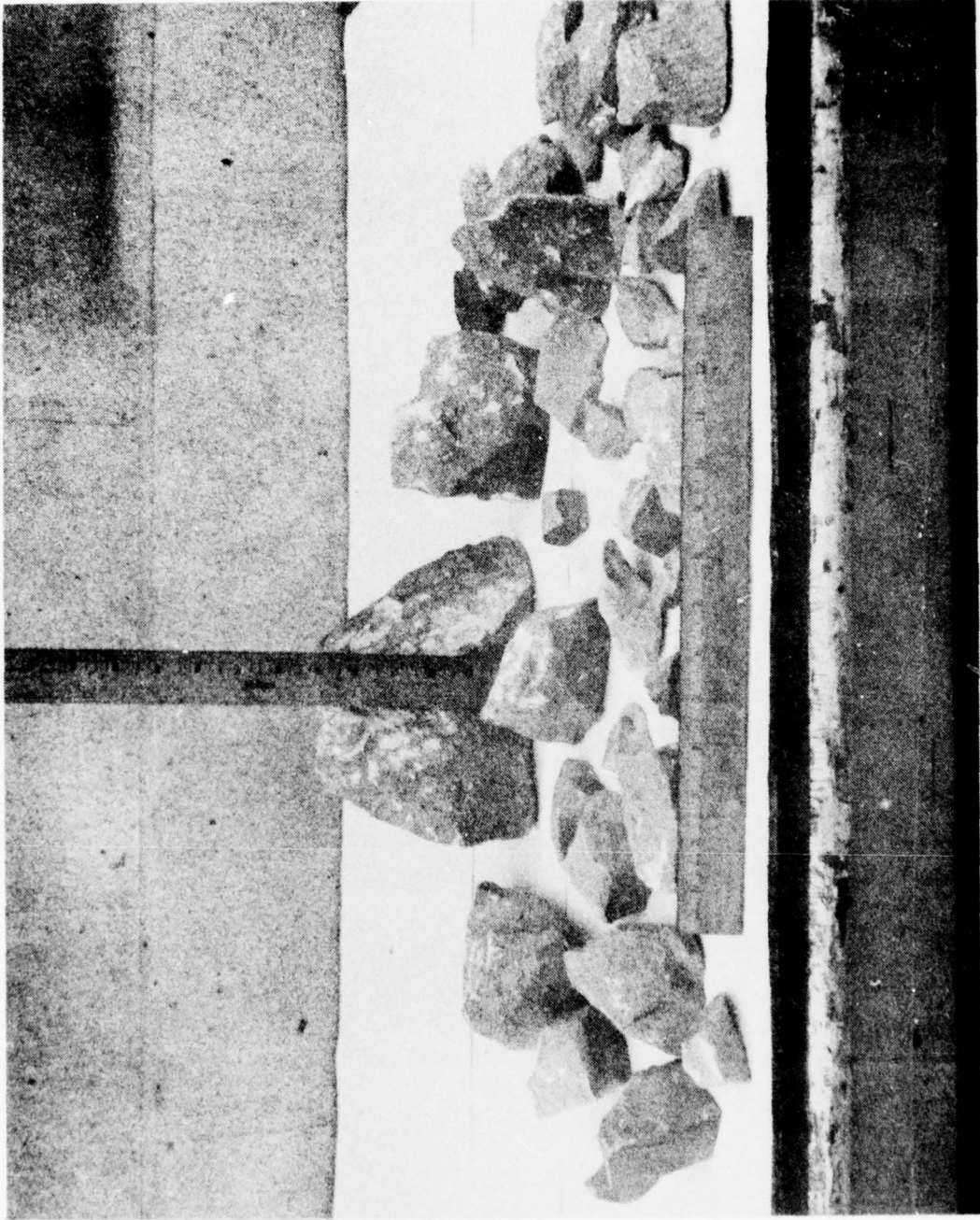

Figure 9. Fragments from Test No. 13

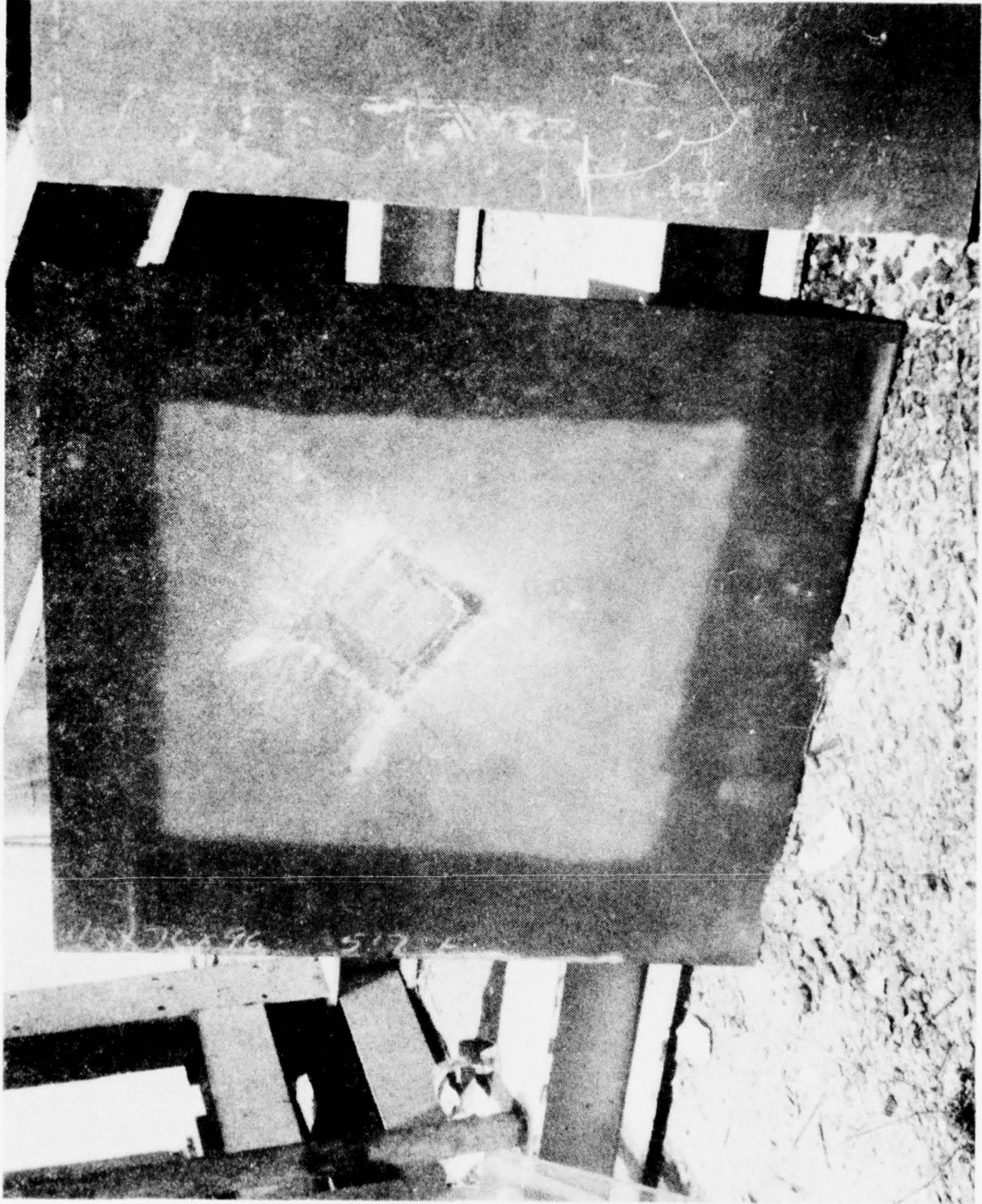

Figure 10. Test No. 14, T-1 Steel Target

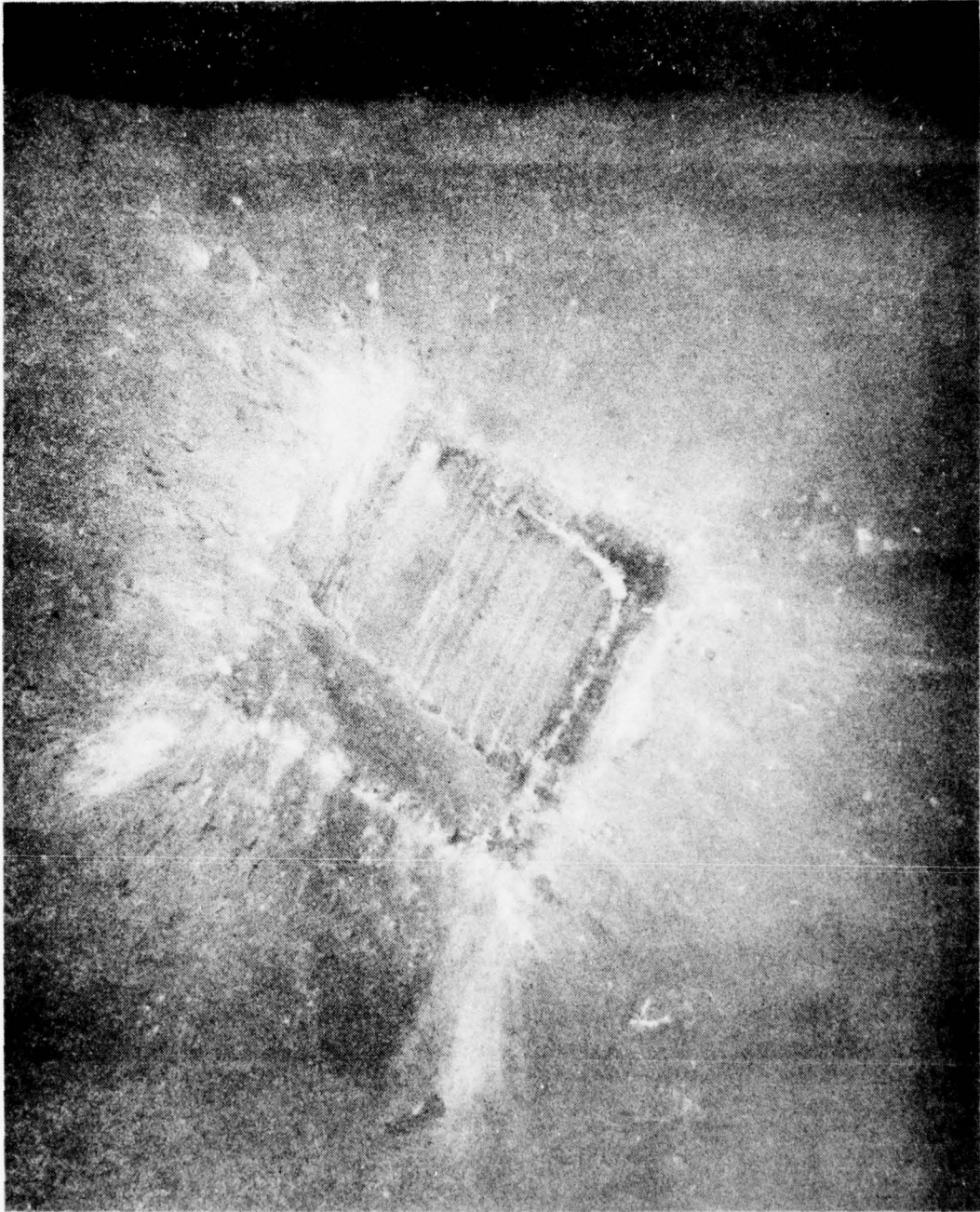

Figure 11. Test No. 14, T-1 Steel Target - Closeup

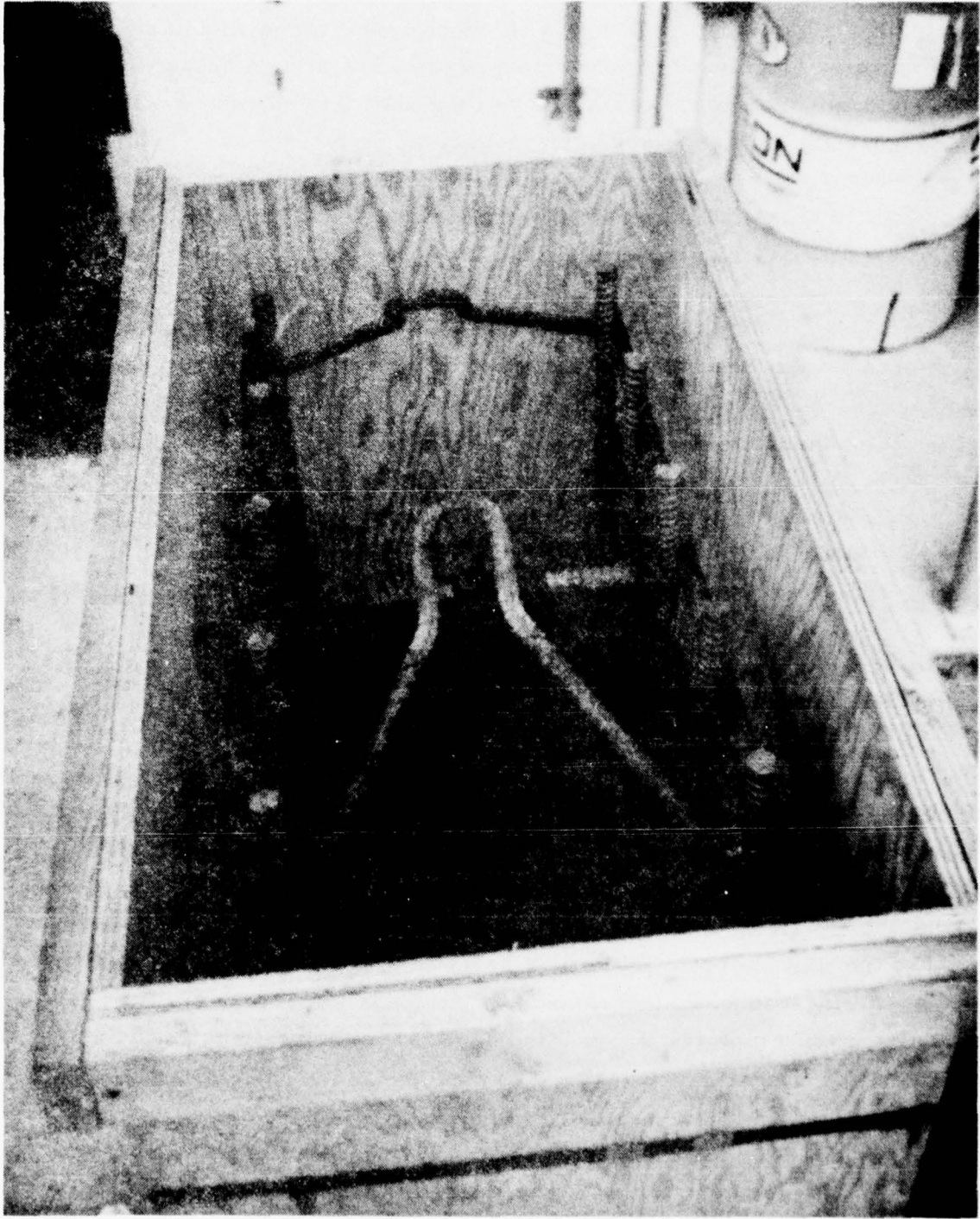

Figure 12. Concrete Target Form and Reinforcing Structure

The sandstone projectile impacted intact at a velocity of 225 fps. Another corner impact was apparent, with an ensuing crater resulting in the target 10.0 in. long x 6.5 in. wide x 1.0 in. deep. The damaged area did not reach the reinforcing bar. Figure 13 shows an overall view of the specimen after test. Figure 14 is a closeup of the damaged area revealing a deposit of fine sandstone dust covering the crater. It was not until this residue was dusted away (Figure 15) that the true crater depth could be measured.

The projectile broke into several very small particles (Figure 16), except for one large piece weighing about 5 lb. Sidespray velocity was again between 300 and 400 fps.

3.2 PARAMETER-VARIATION TEST SERIES

After the diagnostic test series was completed, a meeting was held to review the test results and to outline the parameter-variation tests. Originally, it was thought that the parameter-variation tests would consist of evaluating the projectile-target materials, with the following priorities set for the order of variable testing:

- A. Target thickness (increasing).
- B. Projectile weight.
- C. Projectile angle of impact.
- D. Projectile material.

Since all of the minimum proposed thicknesses withstood the largest sharp edged projectile considered at a 90-degree angle of impact, the first three priorities could be eliminated. This left only projectile material evaluation. All of the sandstone projectiles virtually disintegrated upon impact with any of the target materials. Therefore, it was decided to determine whether this breakup was typical or if it was due to the properties of the particular sandstone used. All materials for the diagnostic test came from Arizona. For this evaluation, WES provided sandstone material from Grand Junction, Colorado to be cut into 50-lb projectiles and fired at 0.5-in. thick T-1 steel and 2.5-in. thick fiber glass.

It was also decided to test thinner targets of T-1 steel and mild steel to find failure points for these materials in an attempt to tie in the results of these tests to predictive curves previously established by MDAC for granite

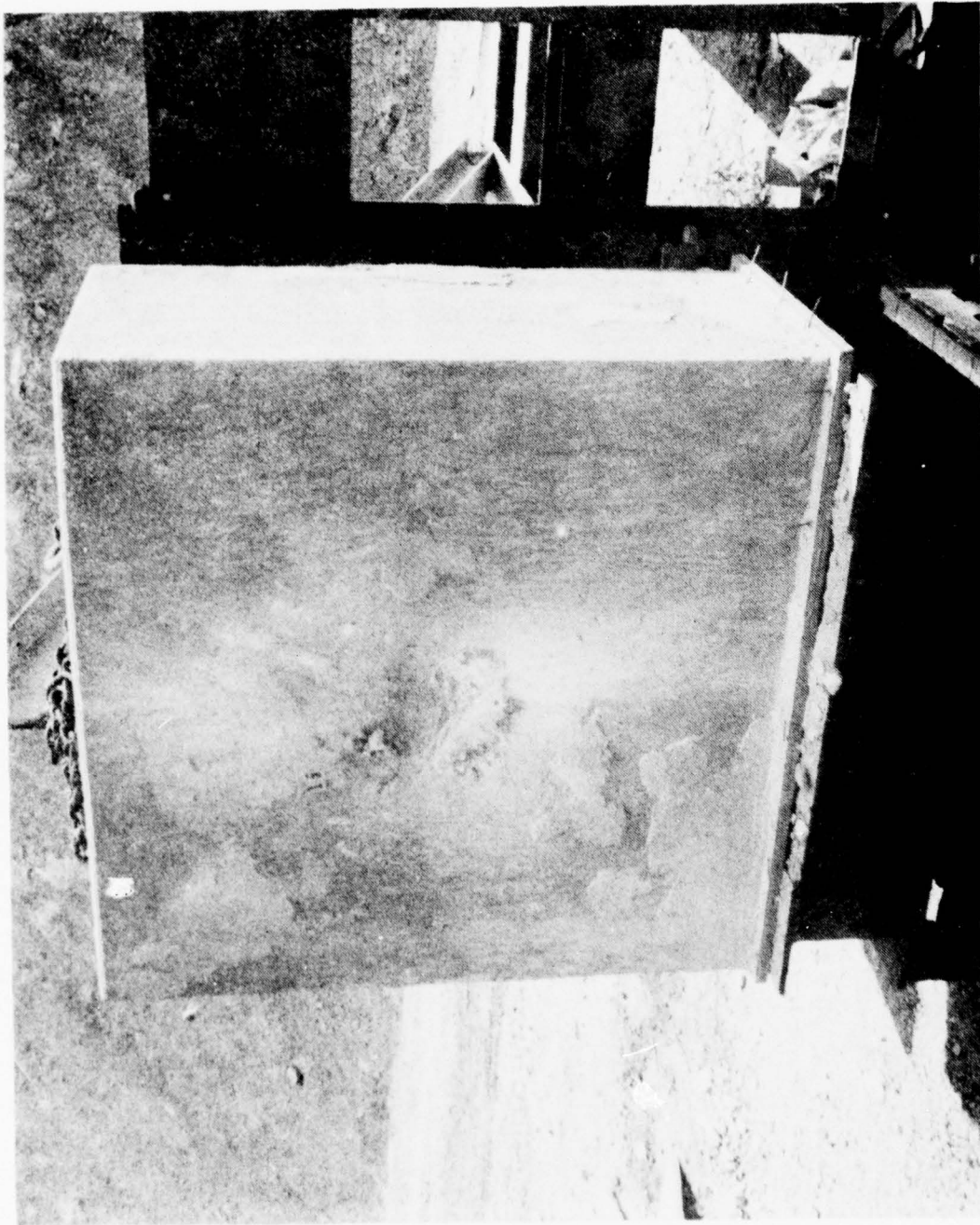

Figure 13. Test No. 15, Concrete Target

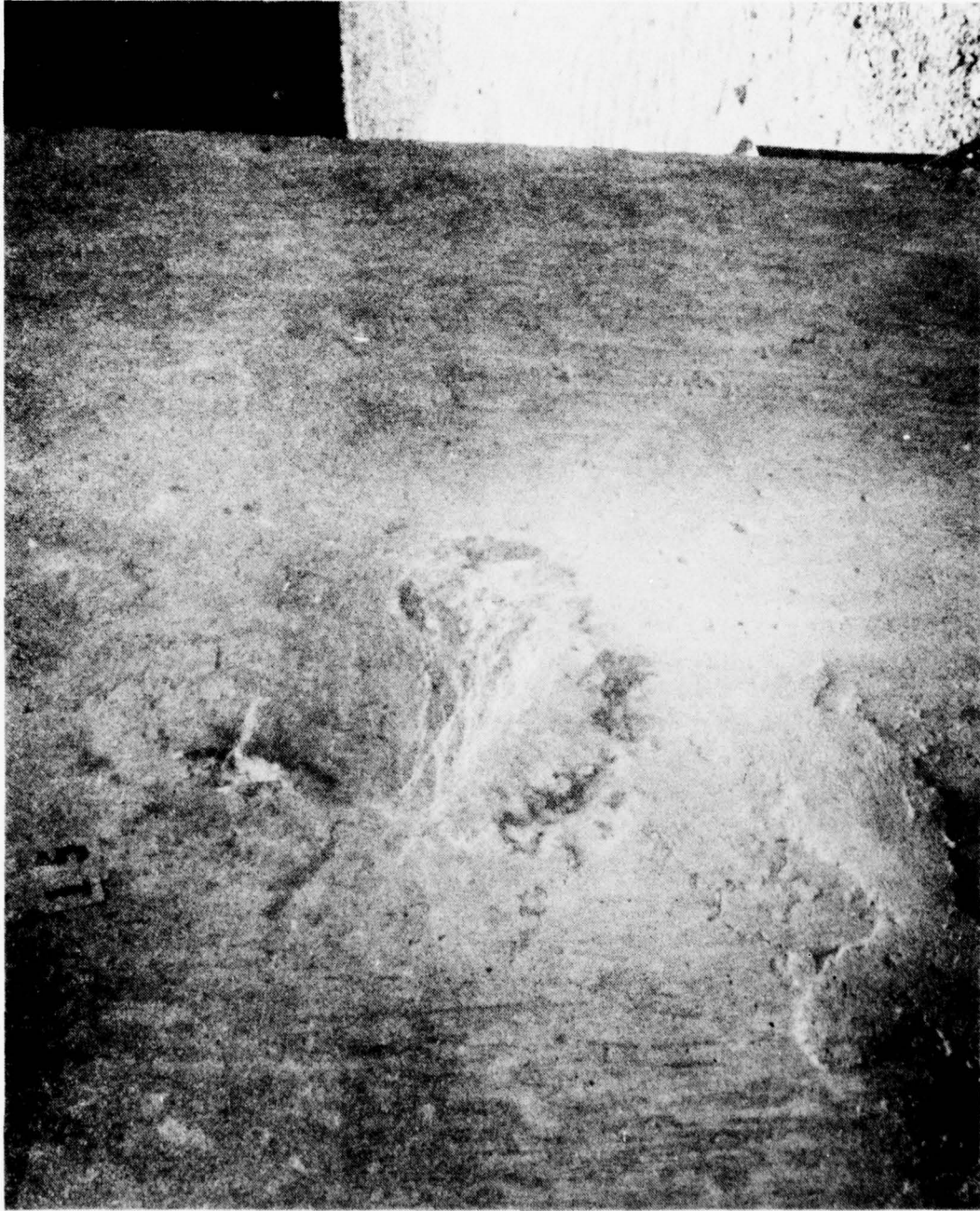

Figure 14. Test No. 15, Concrete Target — Closeup



Figure 15. Test No. 15, Concrete Target Closeup with Residue Removed

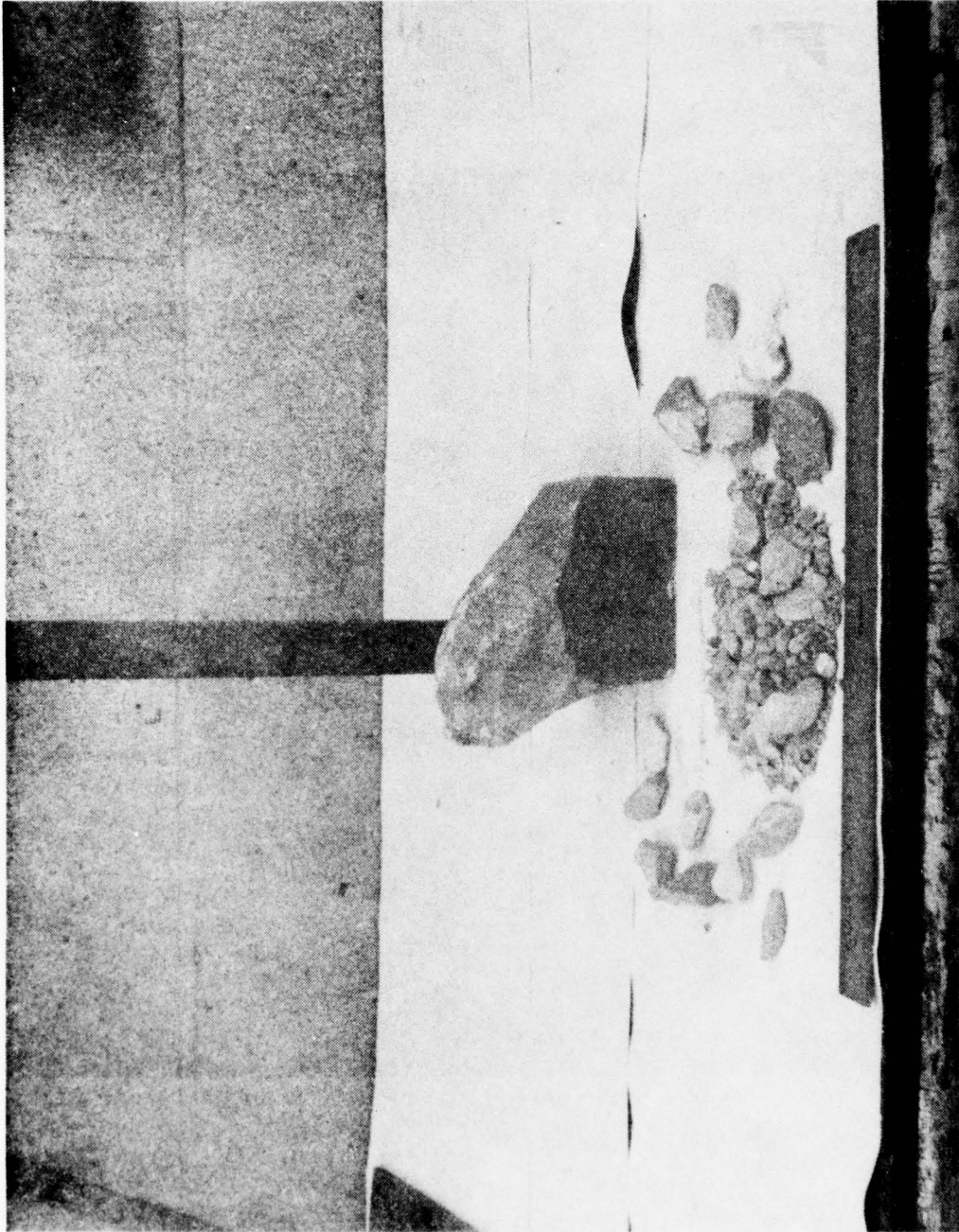

Figure 16. Fragments from Test No. 15

projectiles impacting on mild steel. The final test in this series was a 50-lb sandstone cube impacted against a 1.0-in. thick fiber glass panel to determine the feasibility of utilizing thinner material for BMD structures.

A summary of the parameter-variation tests may be found in Table 2.

3.2.1 Colorado Sandstone Impact Tests

Test No. 16 consisted of impacting a 46.5-lb, 8.3 x 8.3 x 8.3-in. Colorado sandstone cube against a 0.5-in. thick T-1 steel target. The high-speed cameras did not function for this test, but backup data indicated that impact velocity was approximately 240 fps. The projectile shattered into fine particles upon impact. The target had a total deflection of 0.5-in. with a 0.15-in. dent at the impact point. Figures 17 and 18 are post-test photographs Test No. 16.

A 2.5-in. thick fiber glass target was impacted at 230 fps by a 46.0-lb 8.3 x 8.3 x 8.3-in. Colorado sandstone cube for Test No. 17. The projectile completely shattered upon impact with a sidespray velocity of 400 fps. As shown in Figures 19 and 20, only slight surface damage occurred.

3.2.2 Granite Impact Tests

A 10-lb, 5-in. diameter by 5.0-in. long granite cylinder was fired at a 2.5-in. thick fiber glass panel with an impact velocity of 340 fps. The projectile was virtually undamaged while a crater was formed in the fiber glass (Figure 21) 4.8 in. long by 2.5 in. wide by 1.3 in. deep, with damage extending to the backside causing cracking (Figure 22). The damaged area was sectioned, and delamination was detected throughout the thickness of the specimen (Figure 23).

3.2.3 Mild Steel Impact Tests

For Test No. 18 an 8.3 x 8.3 x 8.3-in. Arizona sandstone cube weighing 48.5-lb impacted a 0.25-in. thick mild steel plate at 247 fps (Figure 24). A "vee" shaped hole resulted from a corner impact, as shown in Figures 25 and 26. The projectile broke into large pieces upon impact (Figure 27), with a small particle sidespray velocity of 370 fps.

Table 2 (Page 1 of 2)

PARAMETRIC VARIATION TEST RESULTS

Test No.	Projectile		Target		Impact Velocity (fps)	Results
	Dimensions (in.)	Weight (lb.)	Material	Thickness (in.)		
*16	8.3 x 8.3 x 8.3	46.5	T-1 steel	0.5	240	Projectile shattered into fine particles upon impact. Maximum permanent deflection was 0.5 in. Dent depth at impact point was 0.15 in.
*17	8.3 x 8.3 x 8.3	46.0	Fiber glass	2.5	247	Projectile shattered upon impact. No more than slight surface damage was noted on the target.
*18	5.0(d) x 5.0(l)	10.0	Fiber glass	2.5	340	Projectile remained intact before and after impact. Dent was produced from an edge-on impact. The crater was 4.8 x 2.5 in. with a maximum depth of 1.3 in. The target was split on the backside.
*19	8.3 x 8.3 x 8.3	48.5	Mild steel	0.25	247	Projectile broke upon impact. A "vee" shaped hole was punched in the plate as the result of a corner impact.
*20	8.3 x 8.3 x 8.3	48.5	Mild steel	0.375	246	Projectile chipped slightly upon impact but was essentially left intact. The target was deeply dished, but no spall or penetration was detected. Permanent deflection was 4.0 in. in 48 in. and 1.3 in. in 15.0 in.

Table 2 (Page 2 of 2)
 PARAMETRIC VARIATION TEST RESULTS

Test No.	Projectile		Target		Impact Velocity (fps)	Results
	Dimensions (in.)	Weight (lb.)	Material	Thickness (in.)		
20	8.3 x 8.3 x 8.3	48.5	Fiber glass	0.94	242	The projectile remained intact and completely penetrated the target. The test specimen was broken into four large pieces.
21	8.3 x 8.3 x 8.3	49.0	T-1 steel	0.375	241	Projectile broke into several pieces upon impact. Plate was bowed 1.8 in. in 48.0 in. and 0.7 in. in 15.0 in.
22	8.3 x 8.3 x 8.3	49.0	T-1 steel	0.25	245	Projectile partially damaged from impact. Target was penetrated completely by the projectile.

*Colorado Sandstone Projectile
 +Granite Cylinder Projectile

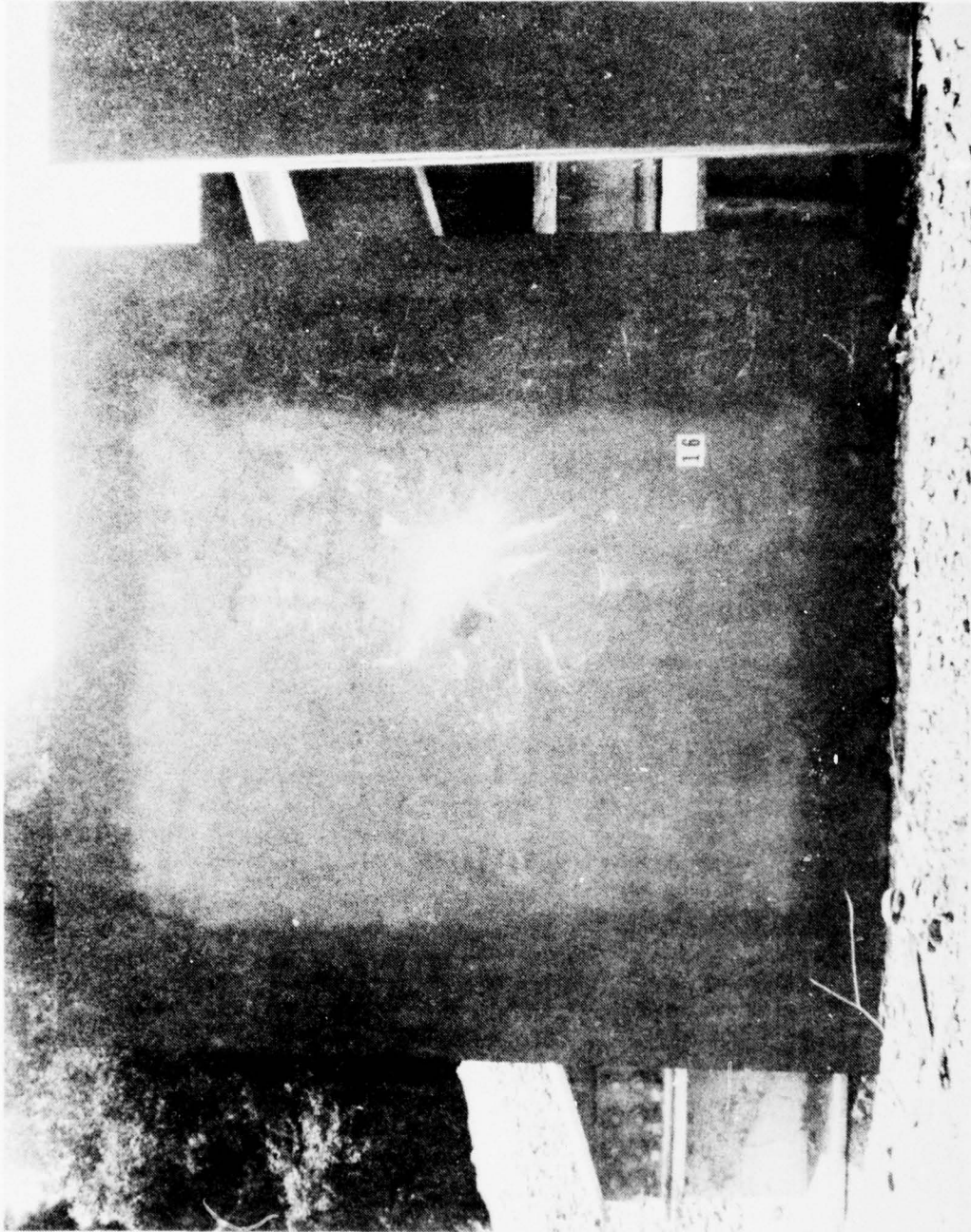

Figure 17. Test No. 16, Colorado Sandstone Versus T-1 Steel



Figure 18. Colorado Sandstone Versus T 1 Steel - Closeup

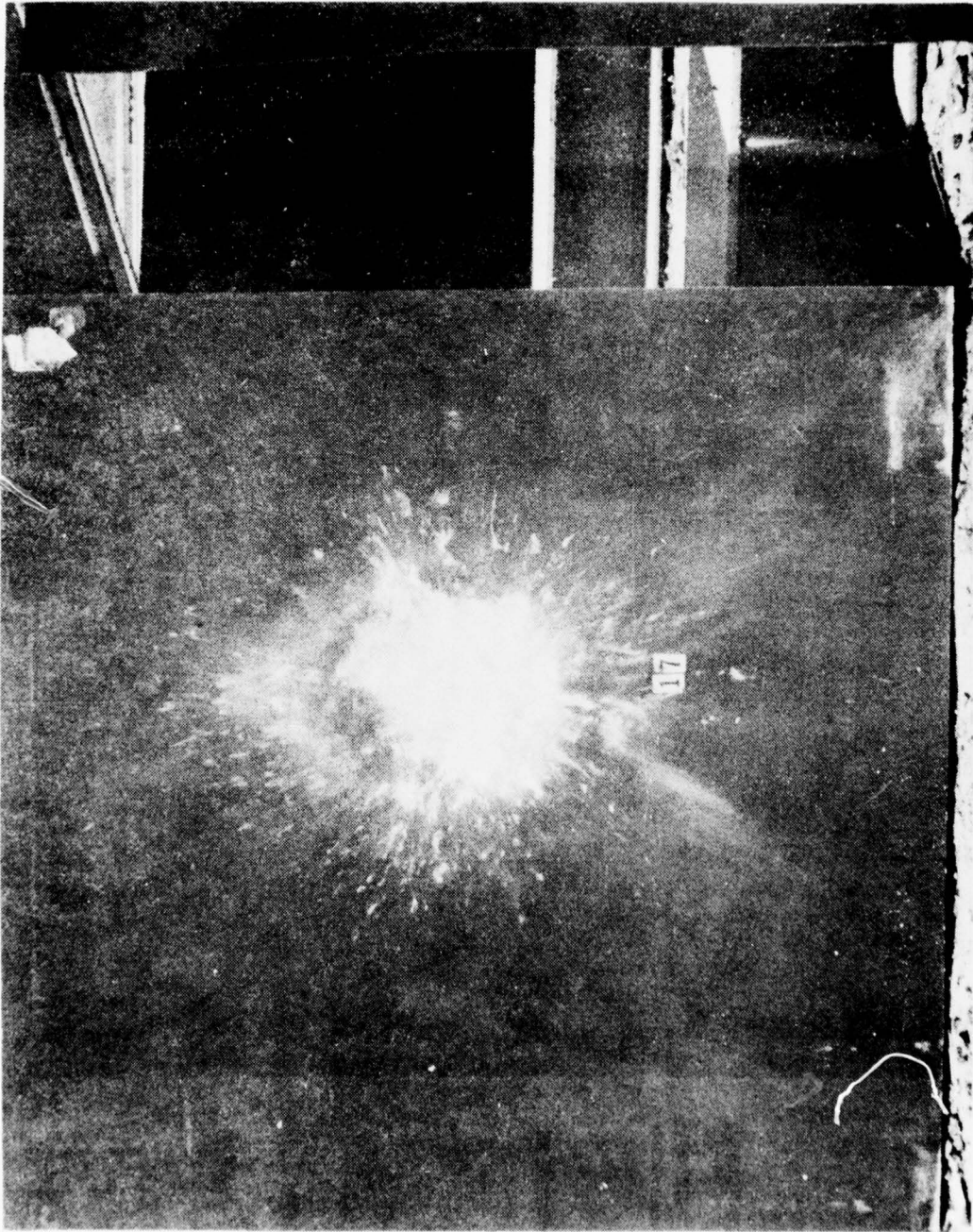

Figure 19. Test No. 17, Colorado Sandstone Versus Fiber Glass

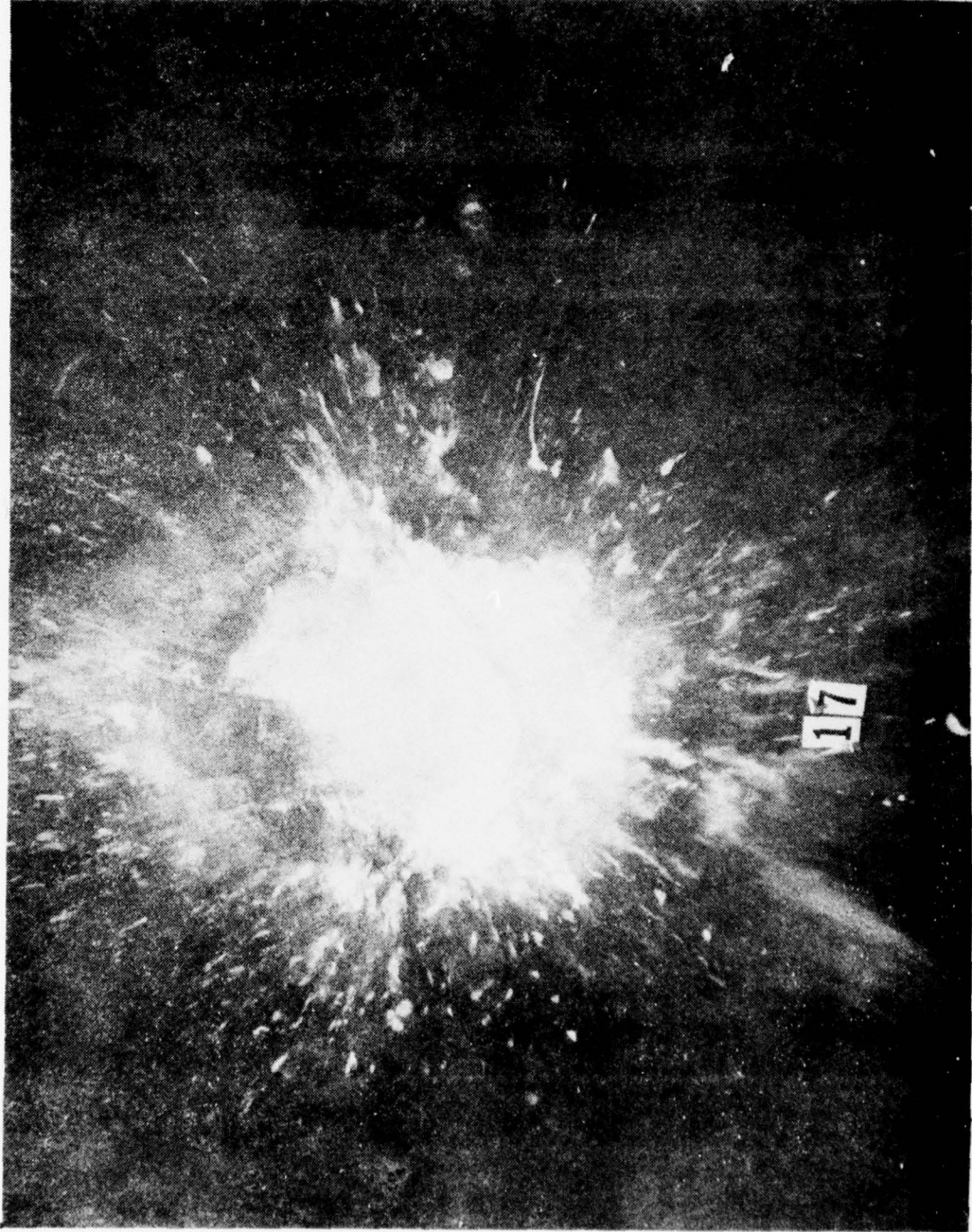

Figure 20. Test No. 17, Colorado Sandstone Versus Fiber Glass — Closeup



Figure 21. Test No. 8, Granite Versus Fiber Glass — Front



Figure 22. Test No. 8, Granite Versus Fiber Glass — Back

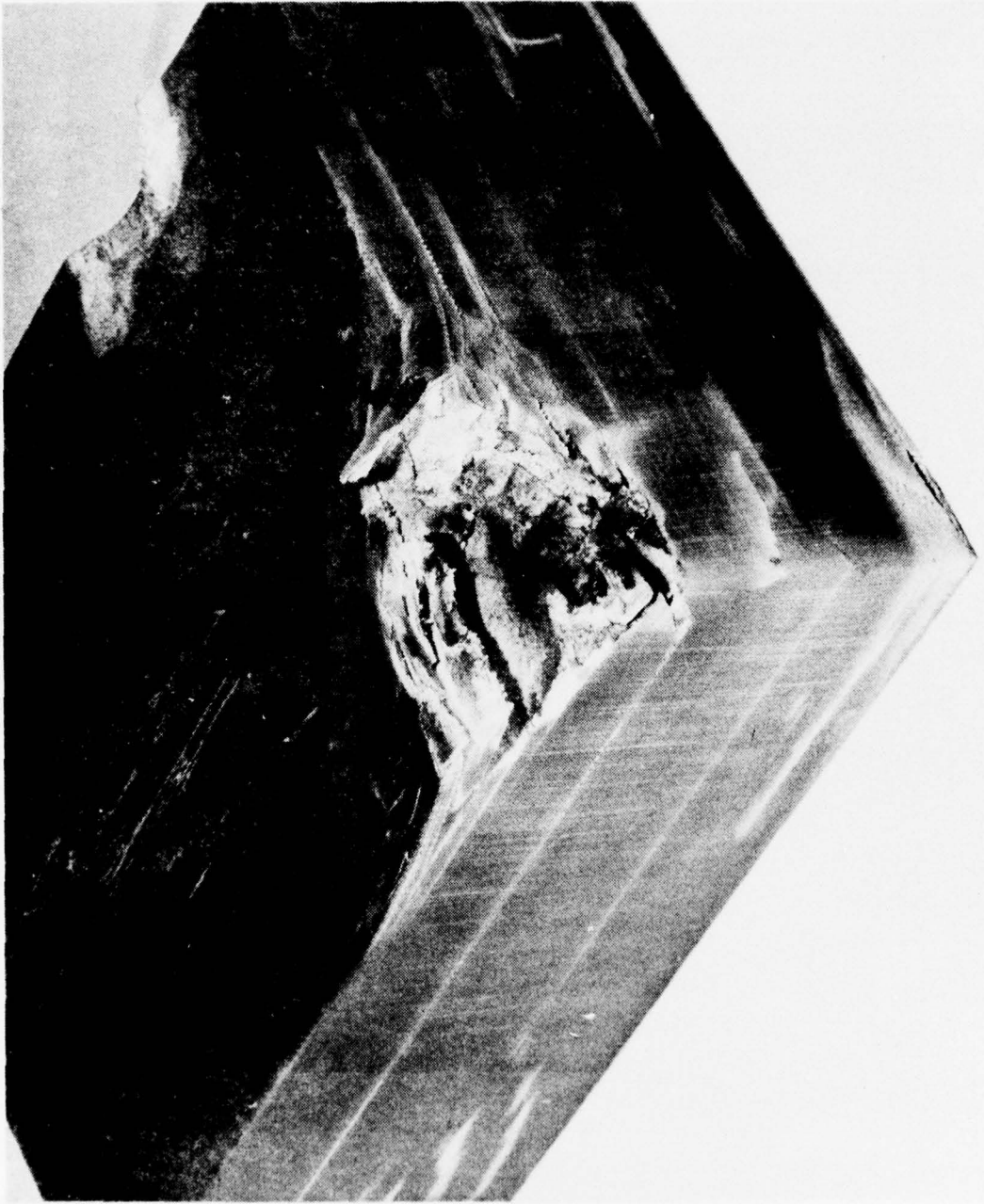

Figure 23. Test No. 8, Granite Versus Fiberglass - Section

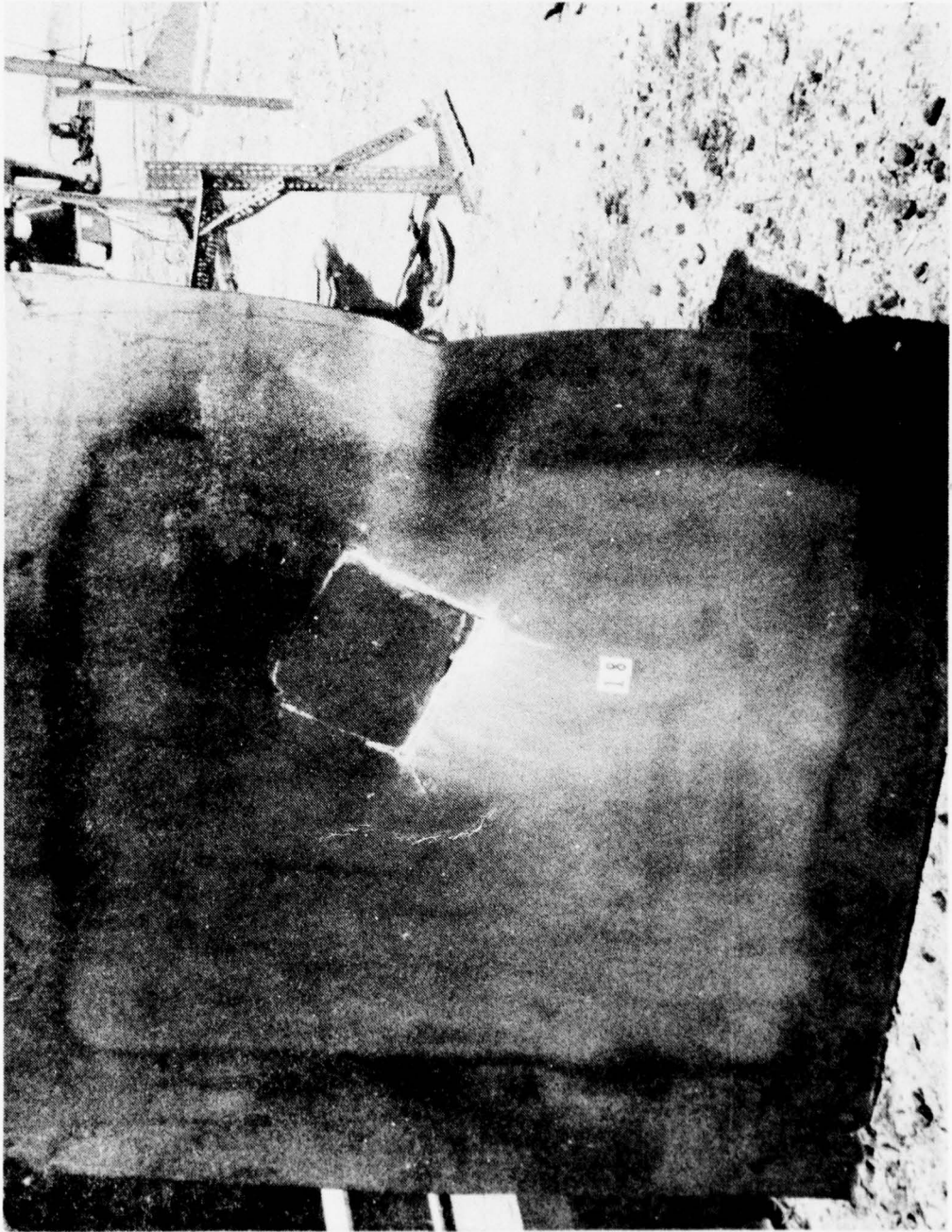

Figure 24. Test No. 18. 0.25-in. Thick Mild Steel Target

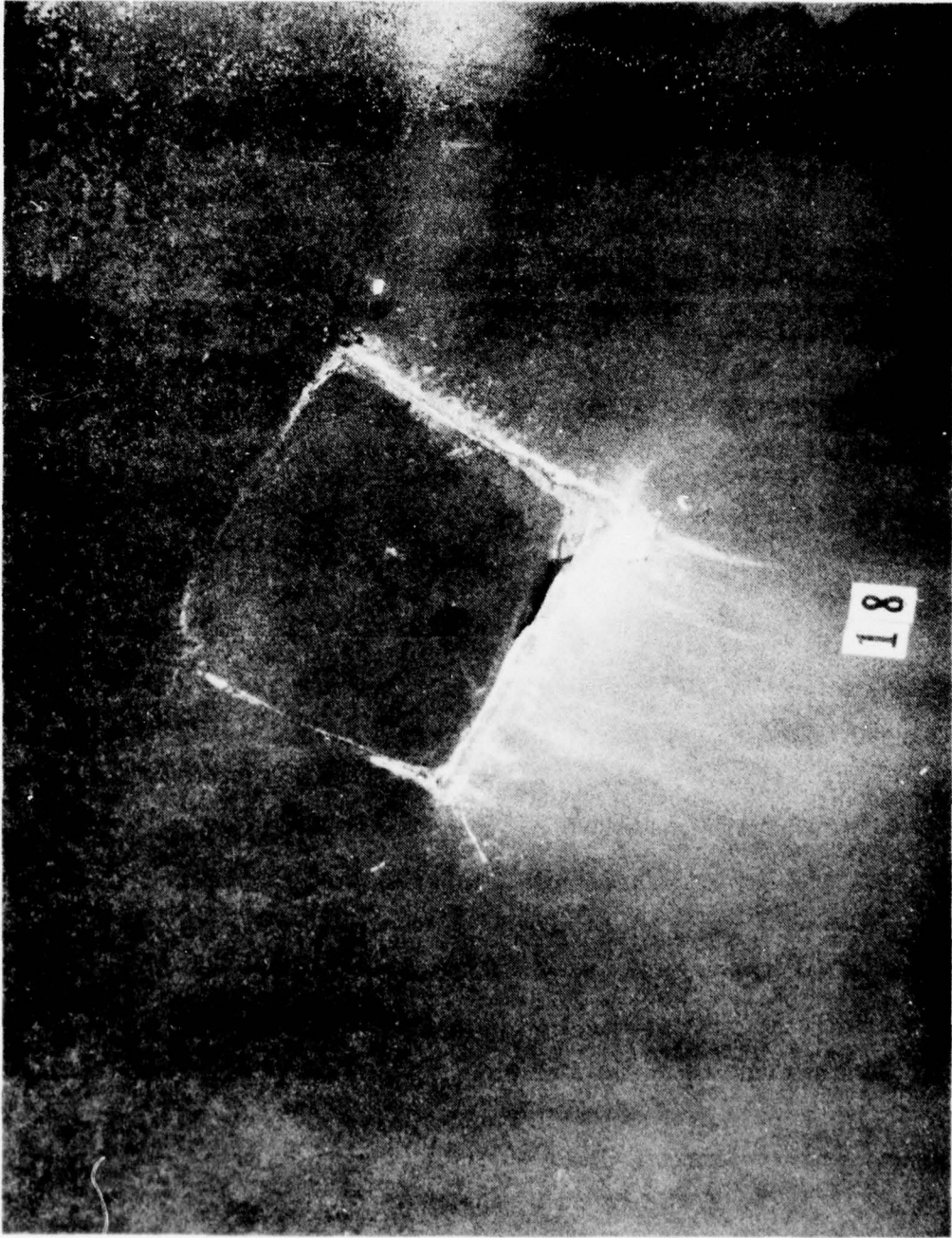

Figure 25. Test No. 18. 0.25-in. Thick Mild Steel Target — Closeup

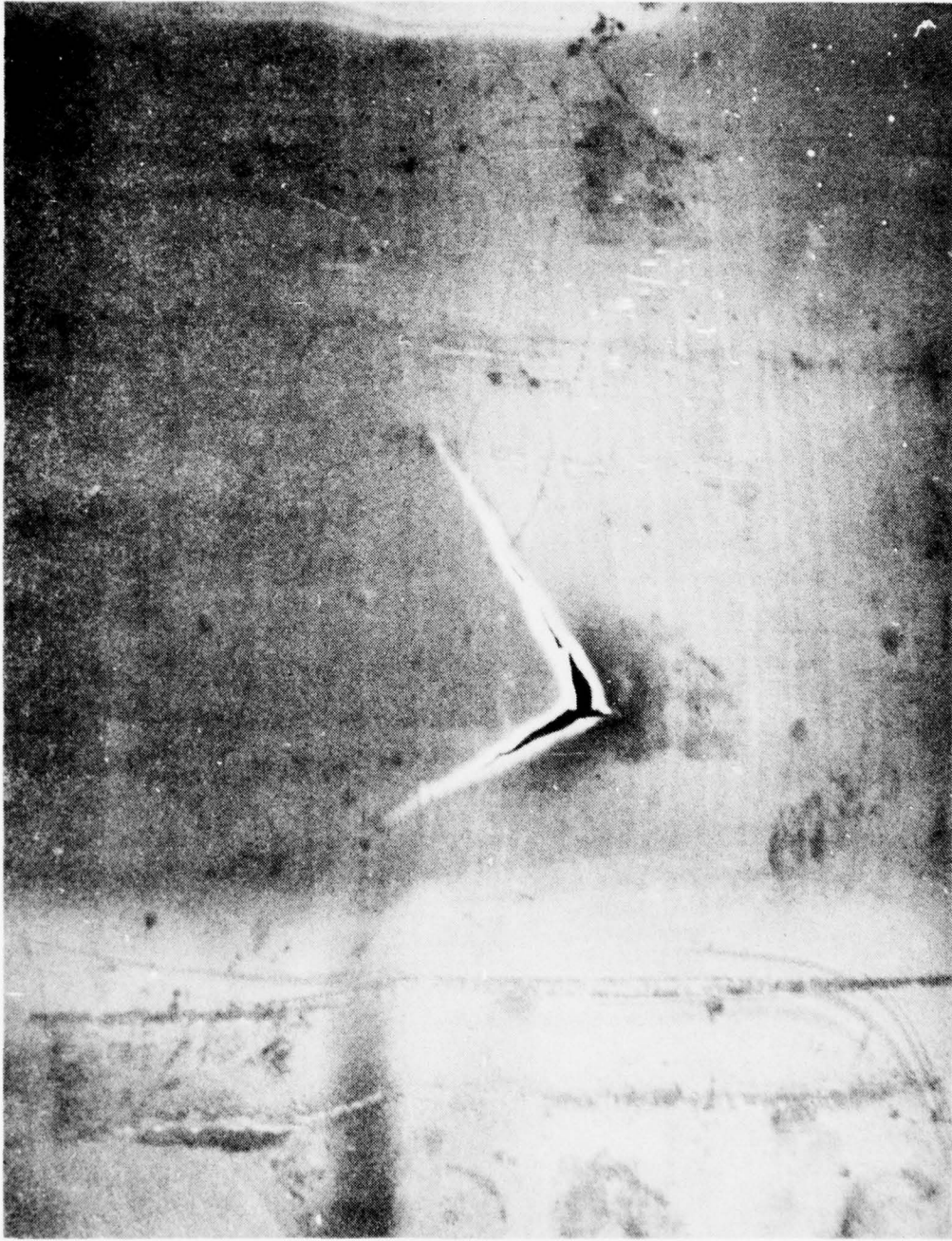

Figure 26. Test No. 18, 0.25-in. Thick Mild Steel Target — Back

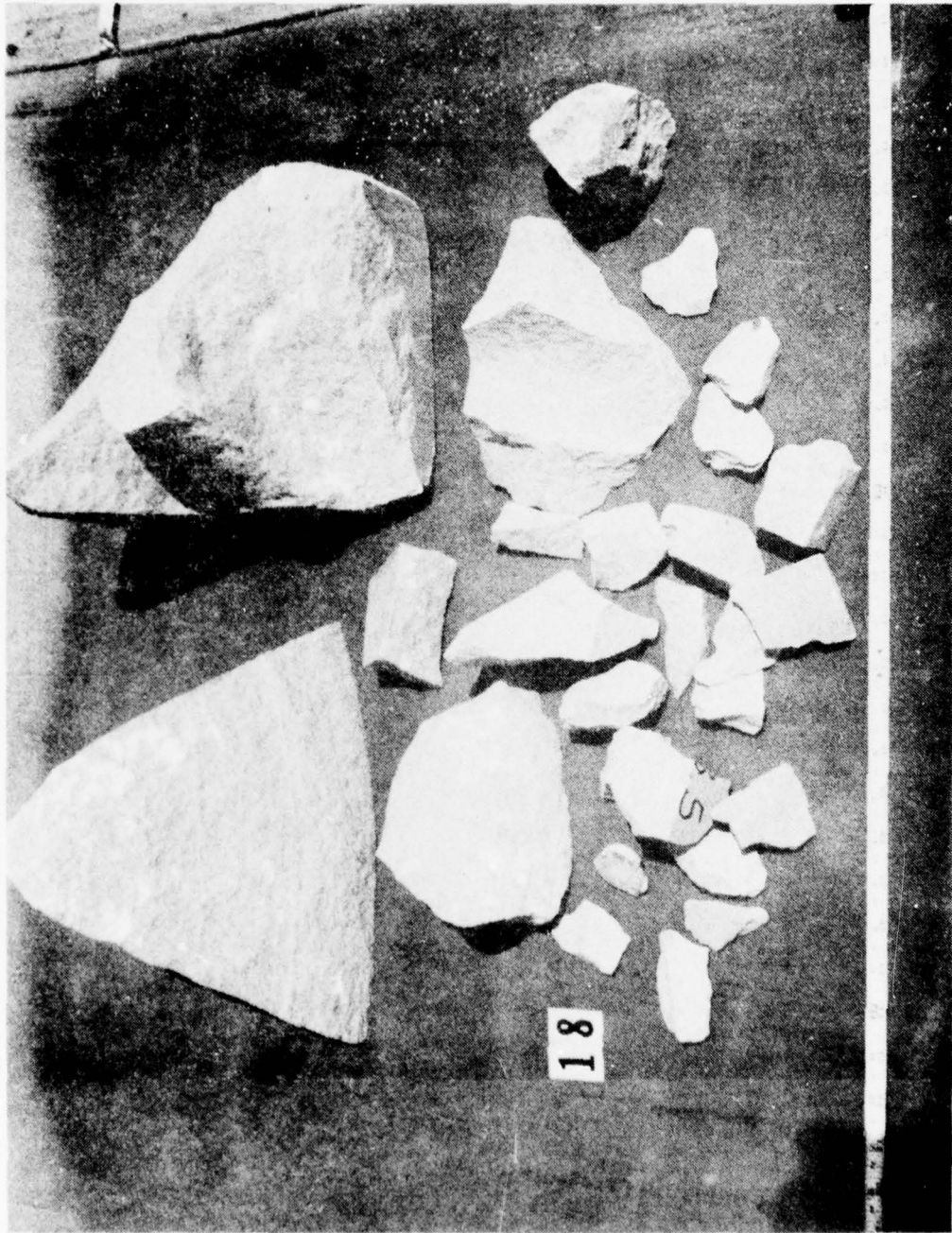

Figure 27. Fragments from Test No. 18

Test No. 19 was the same as Test No. 18, except that a 0.375-in. thick mild steel plate was used for a target. As seen in Figures 28 and 29, very little damage occurred. Total permanent deflection was 4.0 in., with local denting at the impact point of 1.3 in. Damage to the projectile (Figure 30) was negligible.

3.2.4 T-1 Steel Impact Tests

To determine where the failure point was for this material, a 0.375-in. thick target was utilized for Test No. 21. The 8.3 x 8.3 x 8.3-in. Arizona sandstone cube weighed 49.0 lb and had an impact velocity of 241 fps. Total target deflection was 1.8 in., with a dent of 0.7 in. at the impact point (Figures 31 and 32). The projectile broke into several large pieces (Figure 33), with a small particle sidespray velocity of 340 fps.

Since failure did not occur with the 0.375-in. thick plate, a 0.25-in. thick target was used under the same conditions for Test No. 22. The high-speed camera monitoring velocity did not trigger during this test, but backup data indicated impact velocity was approximately 245 fps. A large hole was produced in the target (Figure 34). Figure 35 is a closeup of the forward side, and Figure 36 shows the backside. The actual "punch" failure does not appear to be any greater than that observed with the 0.25-in. thick mild steel plate, but once the cracking began it continued to propagate in three directions. This material, although having greater strength than mild steel, appears to be more sensitive to impact damage once penetration has occurred. The projectile (Figure 37) received very little damage as a result of impact.

3.2.5 Fiber Glass Impact Test

Test No. 20 was performed to determine the survivability of a 0.94-in. thick fiber glass panel to impact by a 48.5-lb, 8.3 x 8.3 x 8.3-in. Arizona sandstone cube. The impact velocity for this test was 242 fps. Although this panel was 36.0 in. x 48.0 in., it was still supported on all four sides similar to all of the previous tests. Figures 38 and 39 show that the specimen was broken into four large pieces upon impact. The projectile (Figure 40) continued to travel after penetration and came to rest about 200 yards past the impact point. The projectile received little damage as a result of impact.

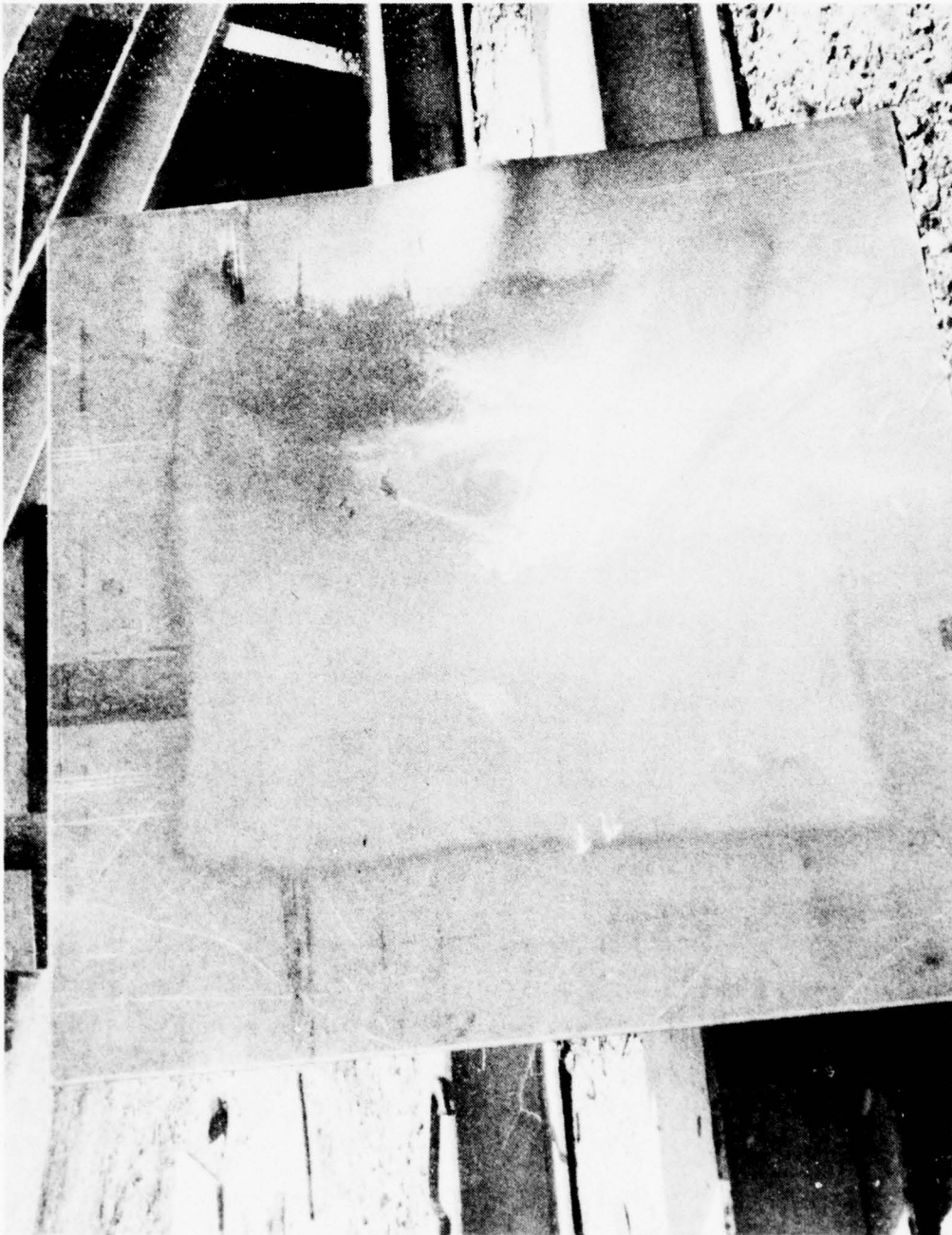

Figure 28. Test No. 19, 0.375-in. Thick Mild Steel Target



Figure 29. Test No. 19, 0.375 in. Thick Mild Steel Target - Closeup

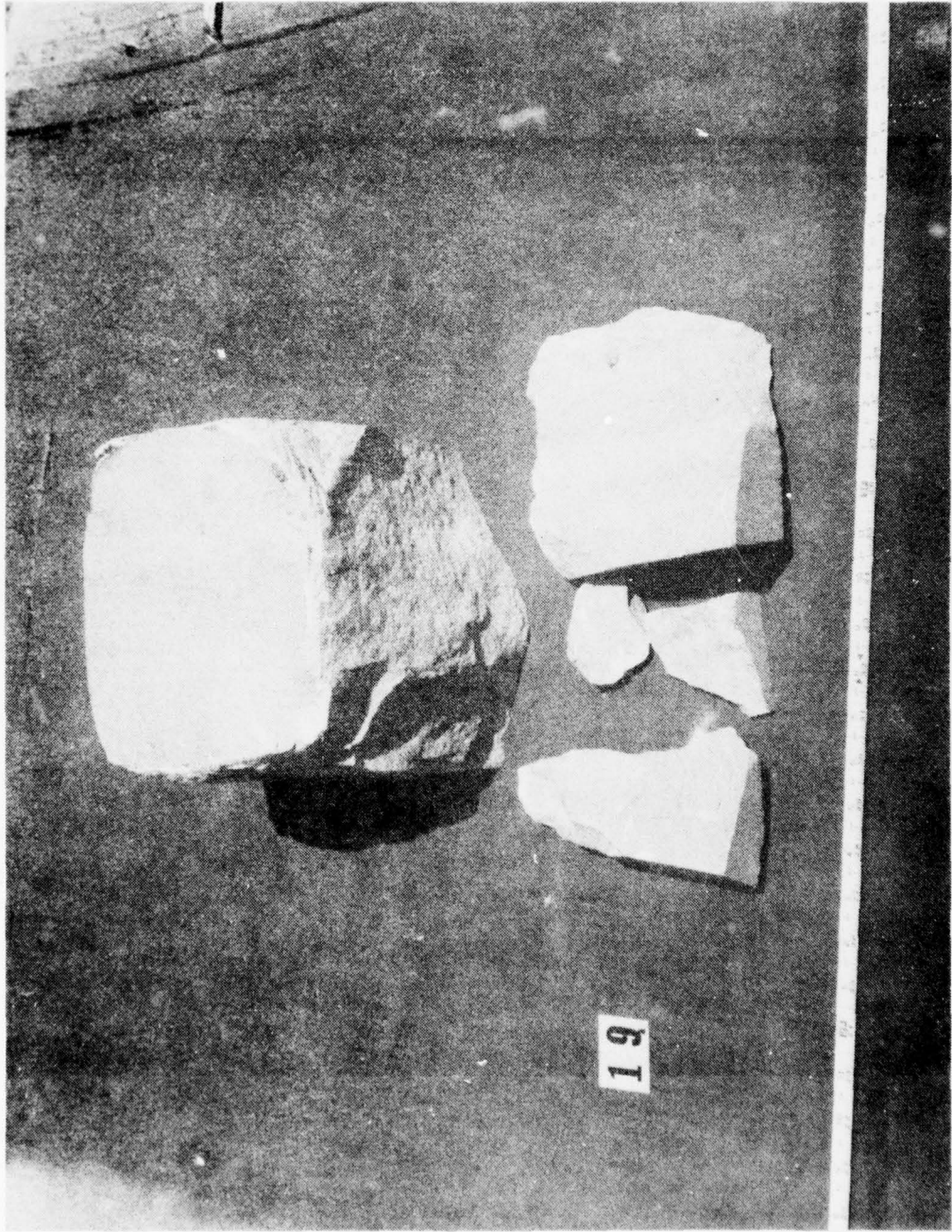

Figure 30. Fragments from Test No. 19

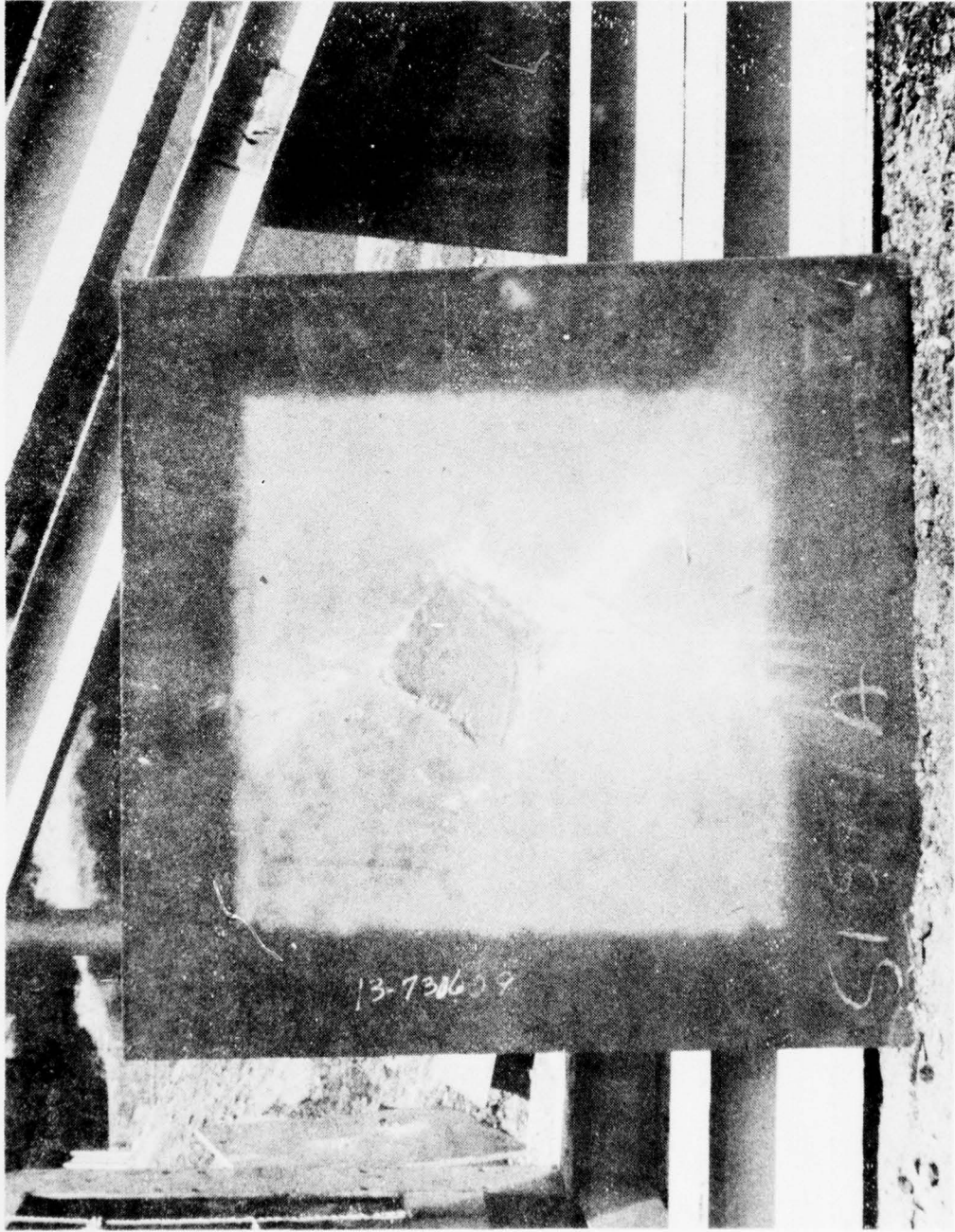

Figure 31. Test No. 21, 0.375-in. Thick T-1 Steel Target



Figure 32. Test No. 21, 0.375-in. Thick T-1 Steel Target — Closeup



Figure 33. Fragments from Test No. 21

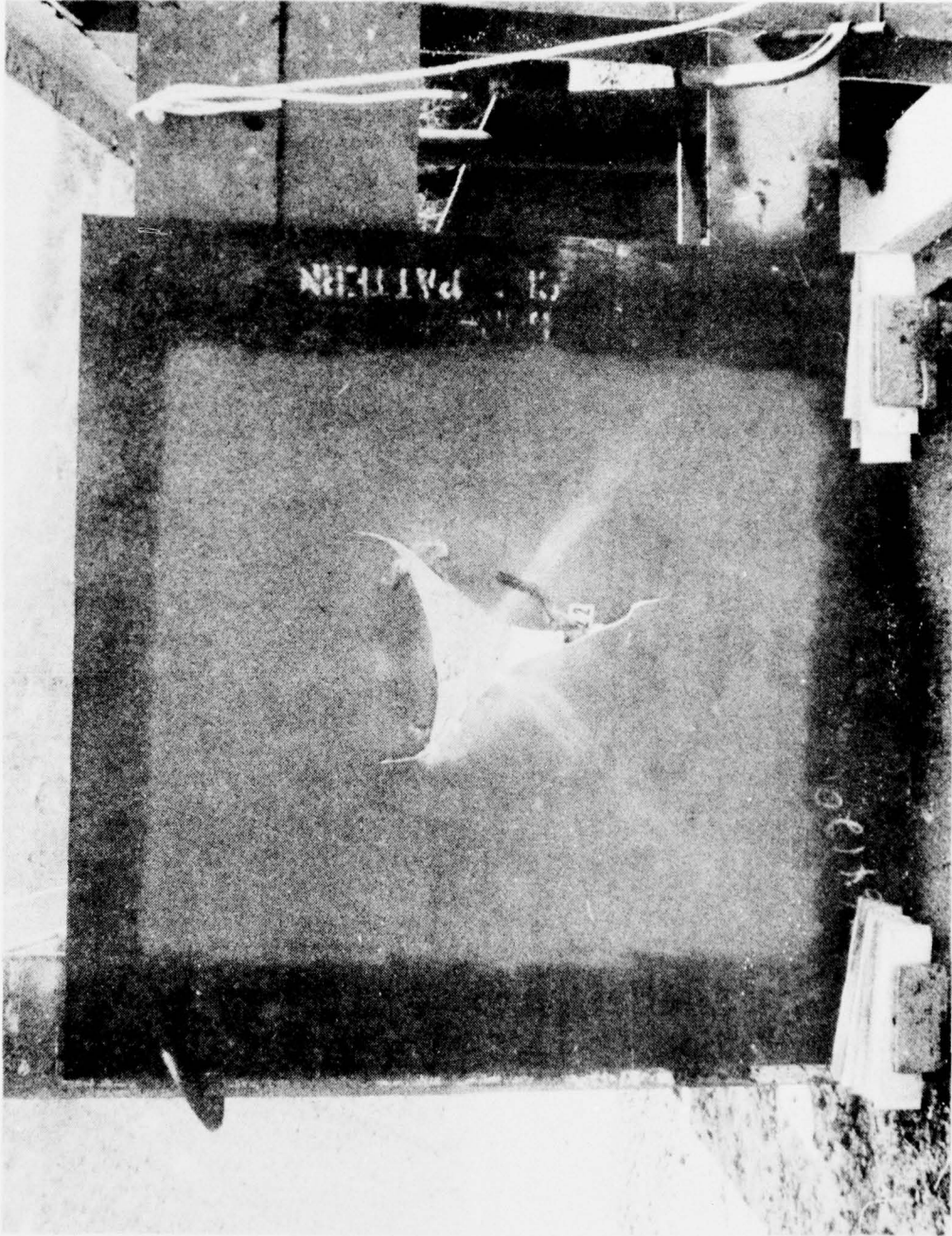

Figure 34. Test No. 22, 0.25 in. Thick T-1 Steel Target

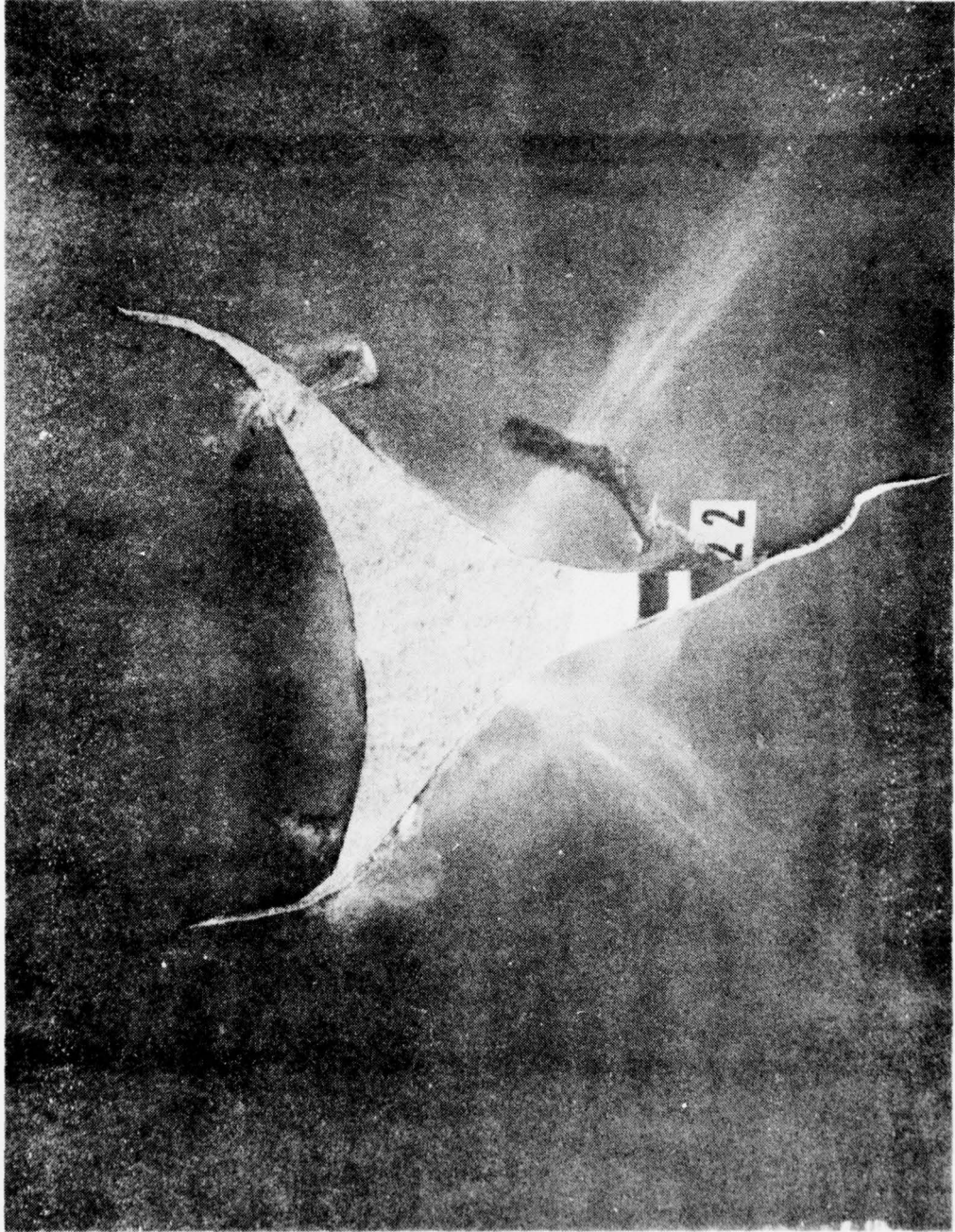

Figure 35. Test No. 22, 0.25 in. Thick T. 1 Steel Target - Front Closeup

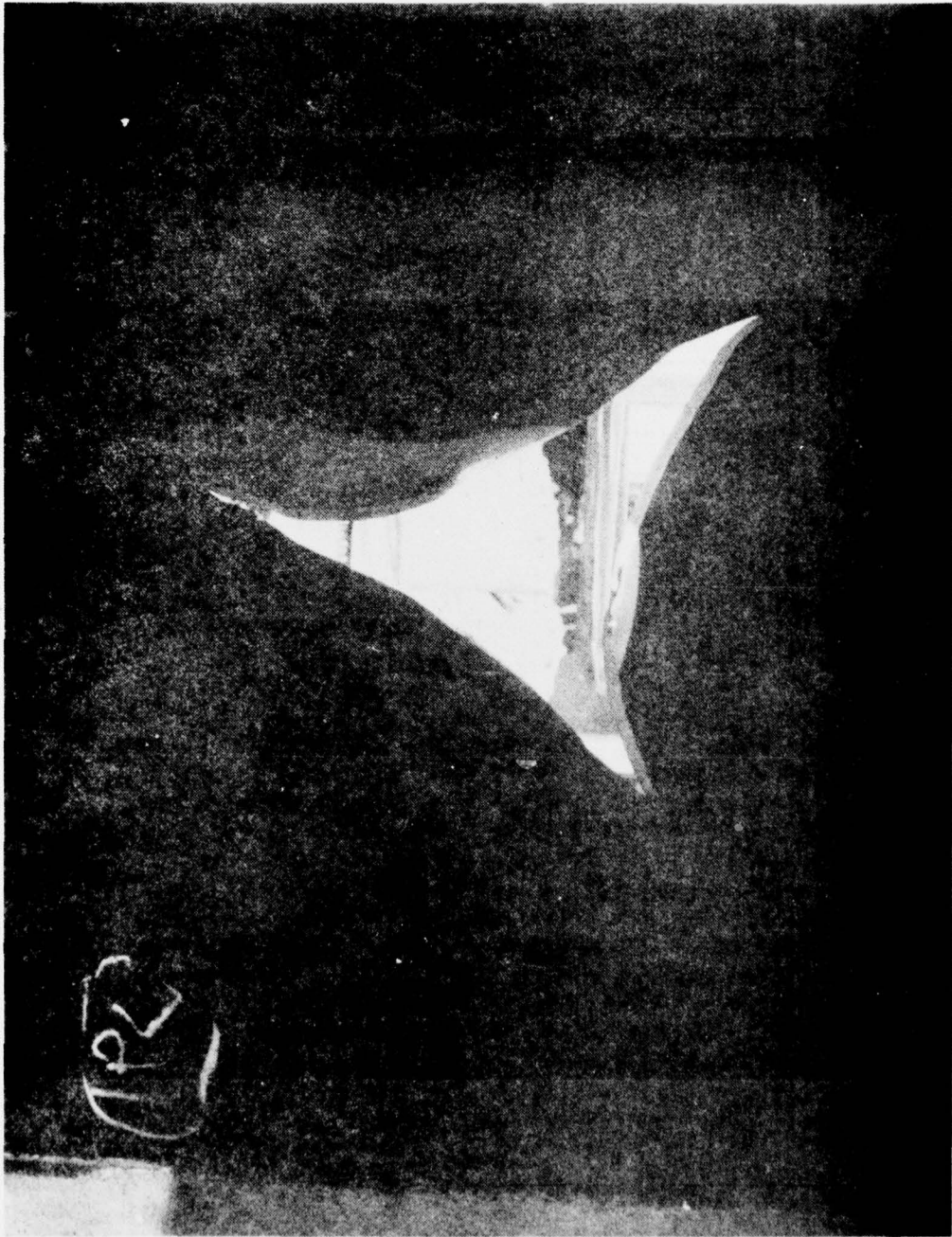

Figure 36. Test No. 22, 0.25-in. Thick T-1 Steel Target — Back Closeup

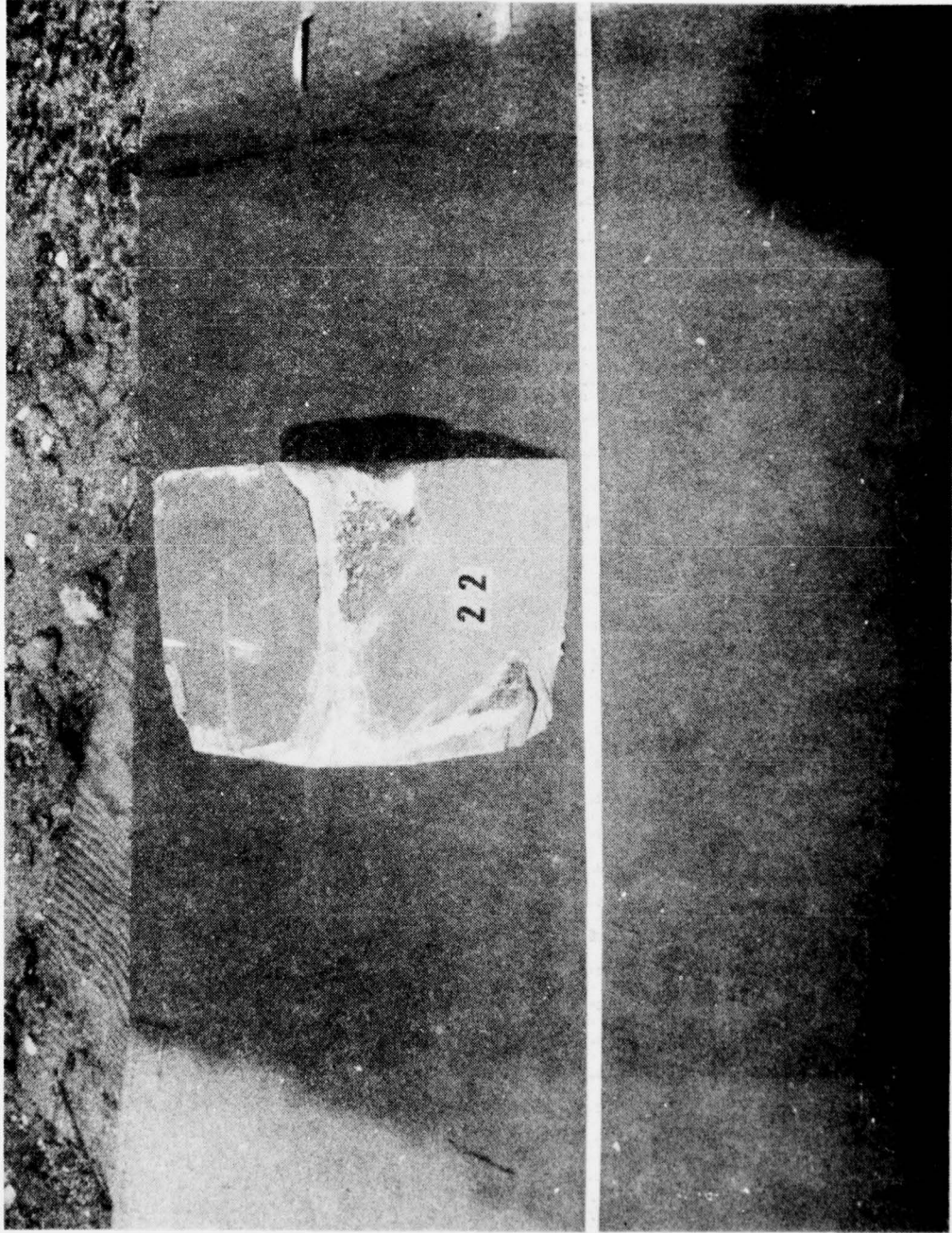

Figure 37. Test No. 22, Projectile After Test

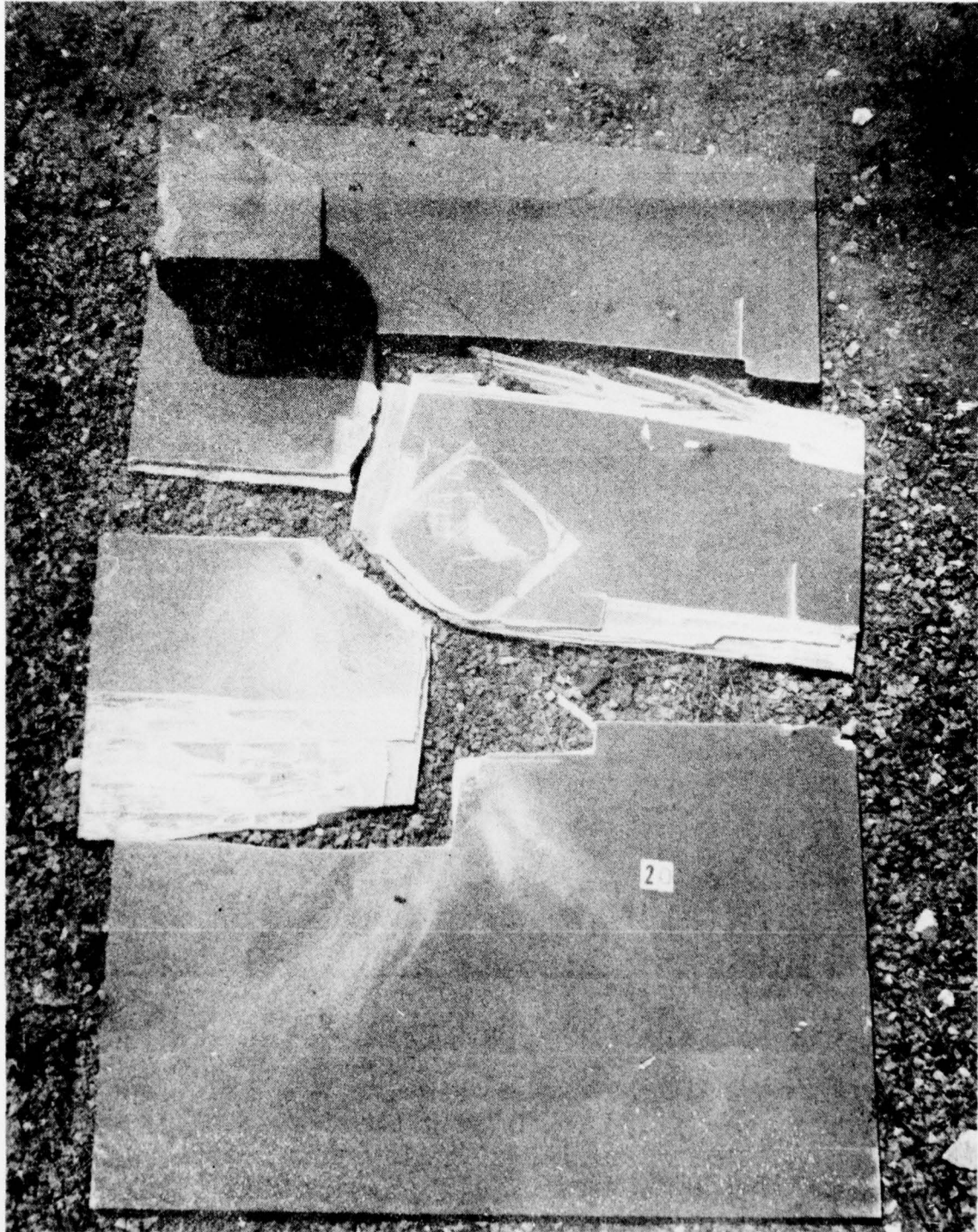

Figure 38. Test No. 20, 0.94-in. Thick Fiber Glass

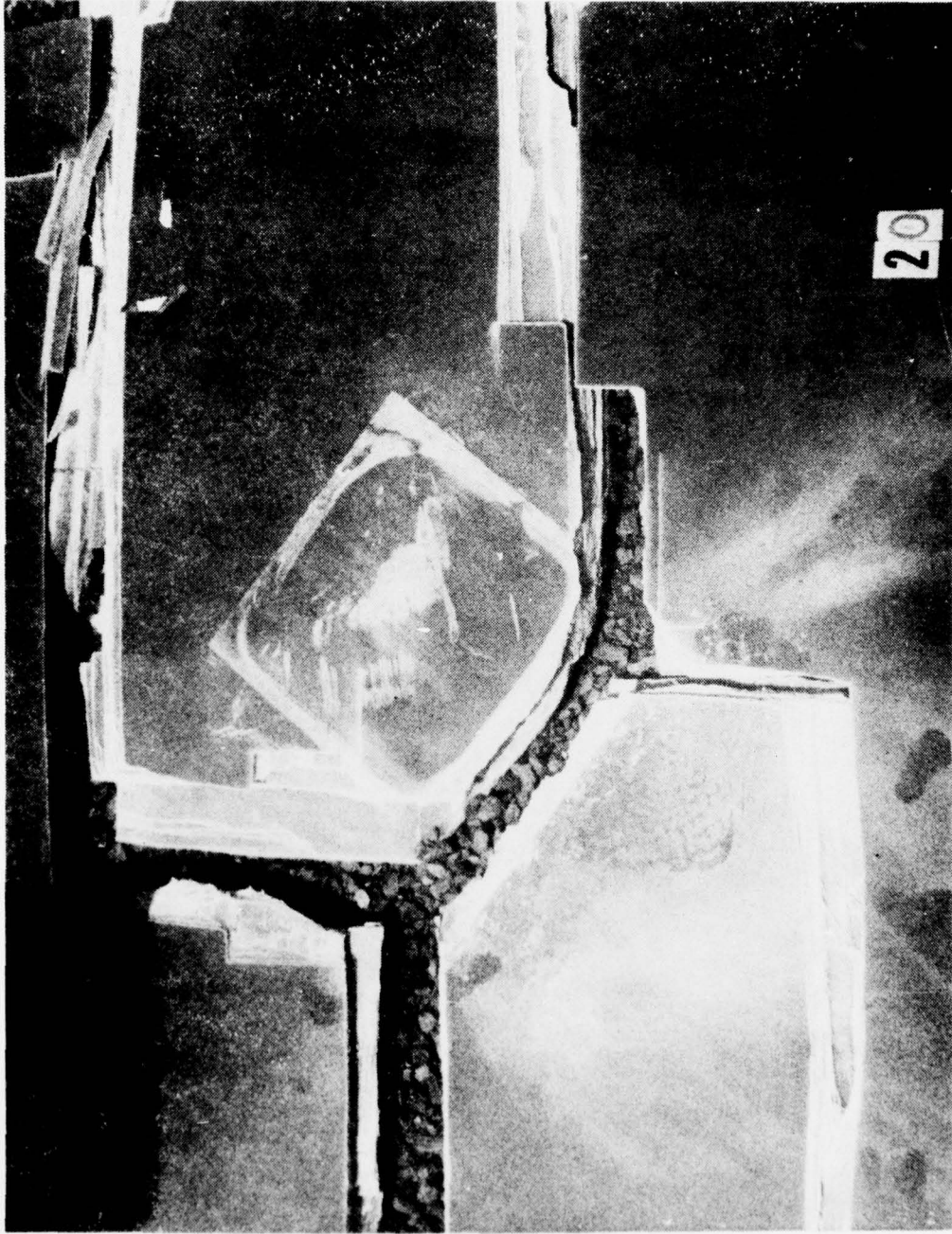

Figure 39. Test No. 20, 0.94-in. Thick Fiber Glass — Closeup

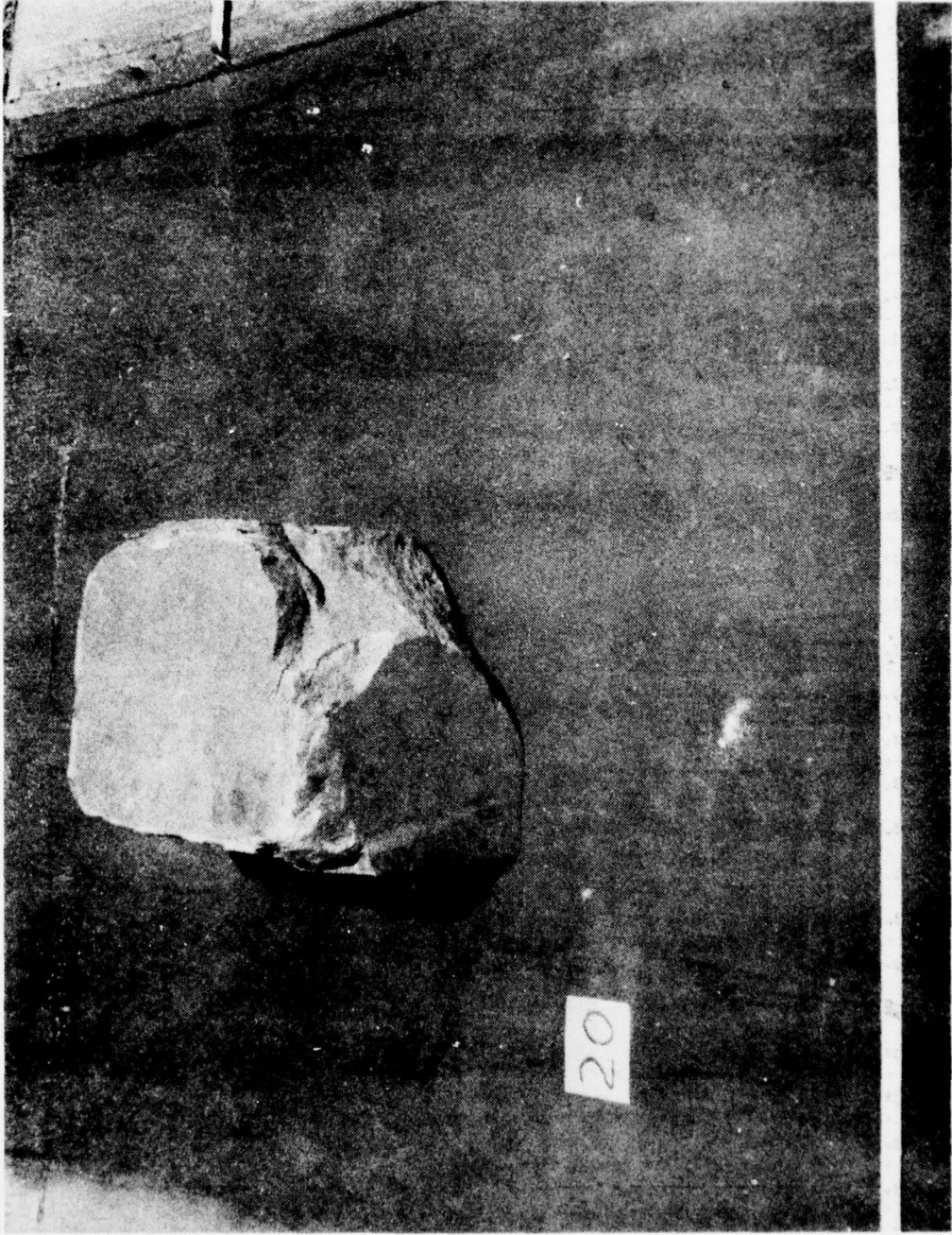

Figure 40. Test No. 20, Projectile After Test

Section 4
SUMMARY AND CONCLUSIONS

This experimental study was performed primarily to investigate the survivability of designated materials to impact damage caused by fallout debris from a nuclear surface burst. The materials and thicknesses were as follows:

- A. Aluminum, 6061-T651, 1.0-in. thick.
- B. Epoxy fiber glass, 2.5-in. thick.
- C. T-1 Steel, 0.5-in. thick.
- D. Concrete, 24.0-in. thick.

All of these materials survived impacts by 50-lb sandstone cubes at velocities of approximately 250 fps. The impact velocity originally planned for these tests was the MDAC calculated terminal velocity for a 50-lb rock, which is about 375 fps, but the sandstone could not survive launch conditions to achieve this velocity without breaking up. Therefore, it was decided to test with impact velocities near to, but exceeding, 200 fps. This was selected because previous cratering tests by WES exhibited this fallout velocity from photographic coverage.

Predictive data for granite (Figure 41) indicates that a 50-lb projectile would breach a 0.5-in. thick steel plate. This has not been demonstrated with granite in these larger sizes, but predictions did hold true in a previous MDAC study program for 5- and 10-lb granite cylinders. Penetration by a 50-lb sandstone projectile did not occur until the target was reduced to a 0.25-in. thick mild steel specimen. This may be compared to penetration of a similar target by a 5-lb granite cylinder at 310 fps or a 10-lb granite cylinder penetrating 0.375-in. thick mild steel at 300 fps. Also, during this study a 10-lb granite cylinder at 340 fps also demonstrated considerably more penetration capabilities than did the 50-lb sandstone at 209 and 247 fps against the 2.5-in. thick fiber glass target.

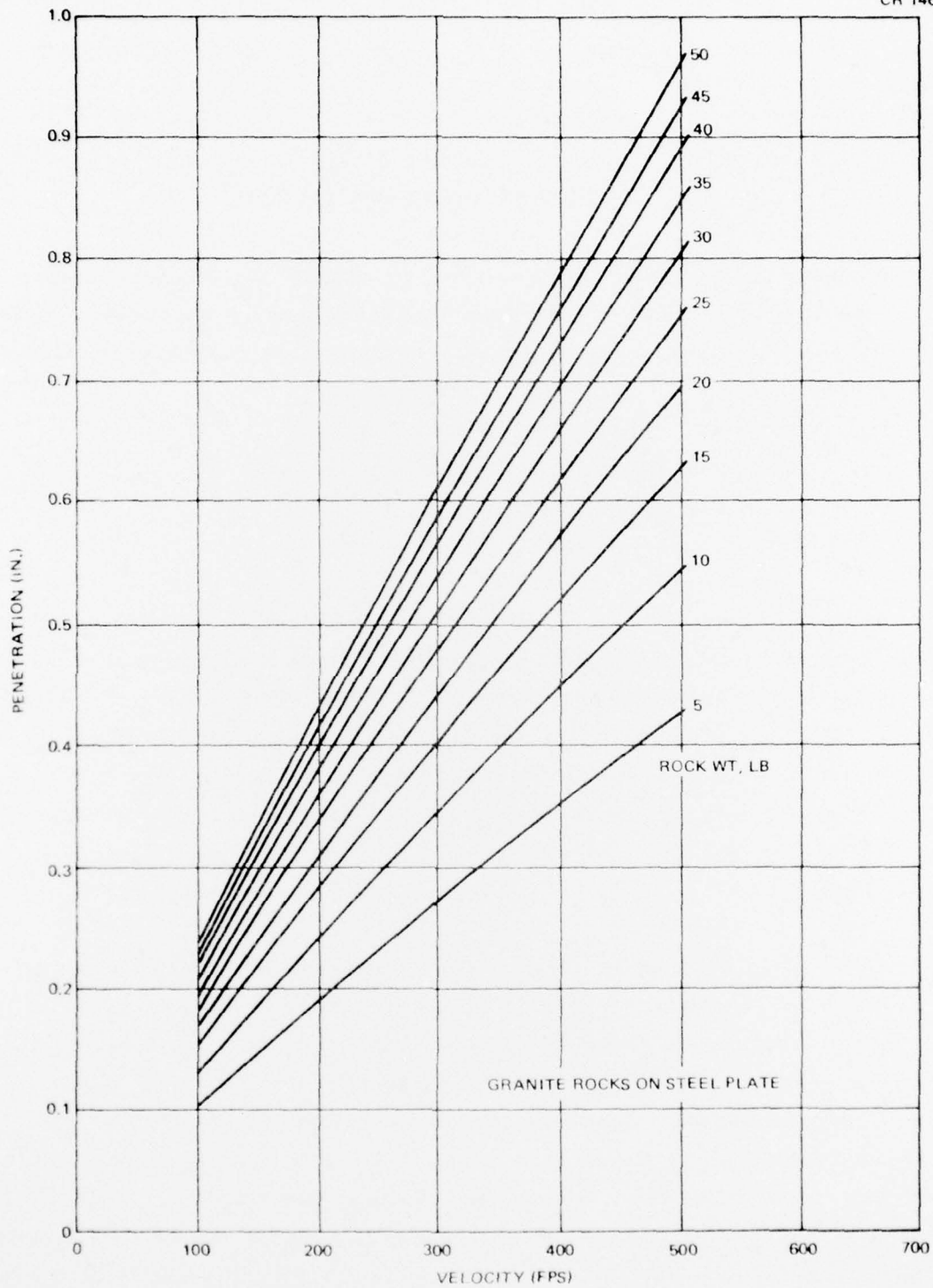

Figure 41. Penetration Versus Impact Velocity

These data would indicate that sandstone is not a penetration threat to BMD structures in the sizes evaluated in this test series because of its low strength. It is also apparent that the predictive data would not apply to materials with less strength than granite. Although penetration is not a problem with sandstone, the deflection of materials such as steel and aluminum may cause serious problems if such materials are utilized for a radar face. The slightest deflection will reduce the effective radar coverage considerably. Another point to consider is the possible damage to elements on the radar face resulting from the projectile sidespray. This projectile breakup, with ensuing sidespray, appears to occur only when the structure is rigid and penetration resistant. This may prove to be an interesting tradeoff study in which thin plates may be utilized for radar faces, allowing only the penetrated area to be damaged instead of the damage resulting from a rigid face in which projectile breakup occurs with some damage radius to dipoles greater than the impact area alone.

It is apparent that although the survivability of the selected materials proved favorable, it is still necessary to be able to predict damage to other more vulnerable materials that may be in critical locations near a nuclear surface burst.

Unclassified
Security Classification

DOCUMENT CONTROL DATA - R & D		
<i>(Security classification of title, body of abstract and indexing annotation must be entered when the overall report is classified)</i>		
1. ORIGINATING ACTIVITY (Corporate author) McDonnell Douglas Astronautics Company--West Huntington Beach, California		2a. REPORT SECURITY CLASSIFICATION Unclassified
		2b. GROUP
3. REPORT TITLE RESEARCH STUDY OF EJECTA IMPACT PARAMETERS		
4. DESCRIPTIVE NOTES (Type of report and inclusive dates) Final report		
5. AUTHOR(S) (First name, middle initial, last name)		
6. REPORT DATE December 1973	7a. TOTAL NO. OF PAGES 64	7b. NO. OF REFS 0
8a. CONTRACT OR GRANT NO. DACA39-72-C-0015	9a. ORIGINATOR'S REPORT NUMBER(S) MDC G4808	
8b. PROJECT NO.	9b. OTHER REPORT NO(S) (Any other numbers that may be assigned this report) U. S. Army Engineer Waterways Experiment Station Contract Report N-73-2	
8c.		
8d.		
10. DISTRIBUTION STATEMENT Approved for public release; distribution unlimited		
11. SUPPLEMENTARY NOTES Prepared under contract for U. S. Army Engineer Waterways Experiment Station, Vicksburg, Mississippi		12. SPONSORING MILITARY ACTIVITY Office, Chief of Engineers, U. S. Army Washington, D. C.
13. ABSTRACT Impact tests were performed to investigate survivability of proposed BMD structural materials to fallout debris from a nuclear surface burst. The materials evaluated included: 1.0-in. thick 060-T651 aluminum; 2.5-in. thick epoxy fiber glass; 0.5-in. thick T-1 steel; 24-in. thick concrete. A specially designed powder gun was utilized to project sandstone missiles weighing 10-, 25-, and 50-lb each at the specified targets. The impact velocity for the 10- and 25-lb projectiles was nominally 300 fps and the 50-lb projectiles impacted at velocities near, but exceeding, 200 fps. The damage incurred in the targets as result of impact was negligible. Thinner plates (0.375- and 0.25-in. thick) of T-1 steel and mild steel were impacted to determine the penetrating capability of a 50-lb sandstone cube. Both 0.25-in. thick plates were penetrated while the 0.375-in. thick plates were only dented. A fiber glass panel 0.94-in. thick was also penetrated by the 50-lb projectile. These tests indicate that sandstone debris in these sizes is a minimal threat to BMD structures although stronger material such as granite has shown considerably more penetration capability in previous tests at MDAC. It is also apparent that previously established predictive data for granite would not apply for materials with less strength than granite such as sandstone.		

DD FORM 1473 1 NOV 66
REPLACES DD FORM 1473, 1 JAN 66, WHICH IS OBSOLETE FOR ARMY USE.

Unclassified
Security Classification

14 KEY WORDS	LINK A		LINK B		LINK C	
	ROLE	WT	ROLE	WT	ROLE	WT
Crater ejecta						
Debris impact						
Fallout						
Impact						
Nuclear explosion effects						
Projectiles						

In accordance with ER 70-2-3, paragraph 6c(1)(b), dated 15 February 1973, a facsimile catalog card in Library of Congress format is reproduced below.

McDonnell Douglas Astronautics Company, Huntington Beach, Calif.

Research study of ejecta impact parameters. Vicksburg, U. S. Army Engineer Waterways Experiment Station, 1973. ix, 59 p. illus. 27 cm. (U. S. Waterways Experiment Station. Contract report N-73-2)

Sponsored by Office, Chief of Engineers, U. S. Army ... under Contract No. DACA39-72-C-0015.

1. Crater ejecta. 2. Debris impact. 3. Fallout.
4. Impact. 5. Nuclear explosion effects. 6. Projectiles.
I. U. S. Army. Corps of Engineers. (Series: U. S. Waterways Experiment Station, Vicksburg, Miss. Contract report N-73-2)
TA7.W34c no.N-73-2