

AD-A038 249

DREXEL UNIV PHILADELPHIA PA DEPT OF MECHANICAL ENGIN--ETC F/G 11/1
ULTRASONIC PROCEDURES FOR THE DETERMINATION OF BOND STRENGTH.(U)
FEB 77 J L ROSE, J W RAISCH

UNCLASSIFIED

AFOSR-TR-77-0372

NL

1 OF 1
AD
A038249

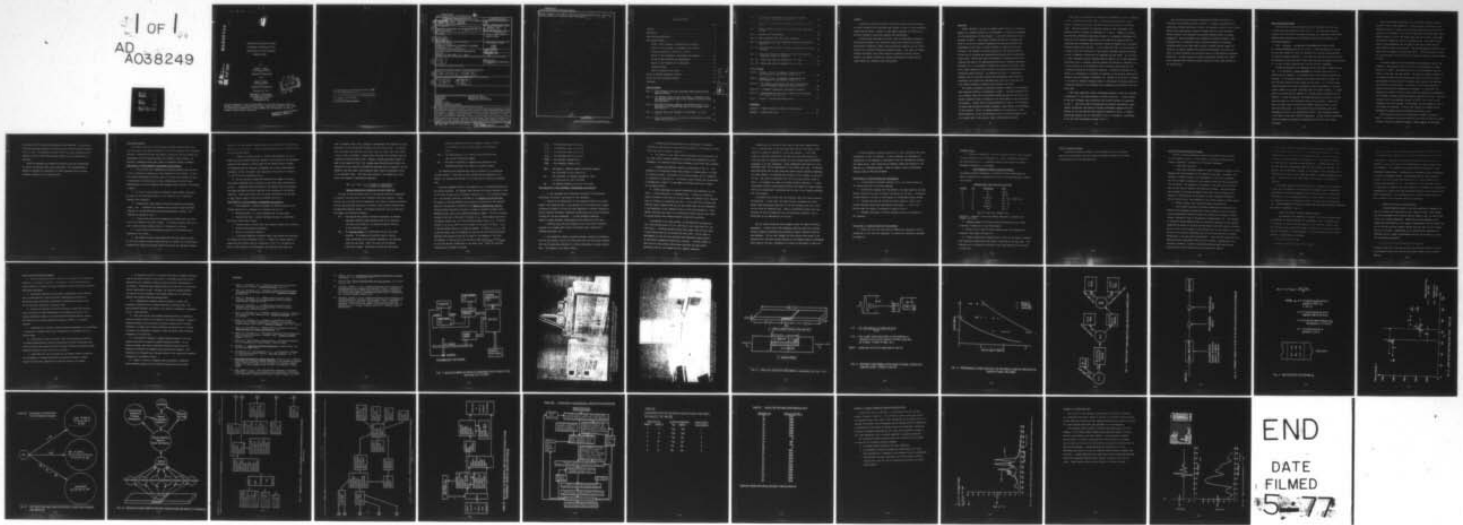

4

ADA 038249

AFOSR Interim Scientific Report
"Ultrasonic Procedures for the
Determination of Bond Strength"

AFOSR-73-2480C

by

Joseph L. Rose
Associate Professor
of
Mechanical Engineering

and

Jack W. Raisch
Graduate Student
in
Mechanical Engineering

February 28, 1977

Department of Mechanical
Engineering and Mechanics
Drexel University
Philadelphia, Pa.

AD No.
DDC FILE COPY.

DDC
APR 15 1977
C

Research sponsored by the Air Force Office of Scientific Research, Office of
Aerospace Research, United States Air Force, Grant Number AFOSR-73-2480, under
the direction of Charles Hays. This document has been approved for public
release; distribution is unlimited.

Approved for public release;
distribution unlimited.

AIR FORCE OFFICE OF SCIENTIFIC RESEARCH (AFSC)
NOTICE OF TRANSMITTAL TO DDC
This technical report has been reviewed and is
approved for public release IAW AFR 190-12 (7b).
Distribution is unlimited.
A. D. BLOSE
Technical Information Officer

function analysis, and adaptive search and learning techniques for linear and nonlinear models are currently being investigated.

100-57-21-1000

<p>SECRET</p>	<p>NO INFORMATION IS TO BE RELEASED FROM THIS DOCUMENT TO ANY OTHER AGENCY OR INDIVIDUAL WITHOUT THE EXPRESS WRITTEN PERMISSION OF THE OFFICE OF THE DIRECTOR, NATIONAL SECURITY AGENCY</p>
<p>SECRET</p>	<p>NO INFORMATION IS TO BE RELEASED FROM THIS DOCUMENT TO ANY OTHER AGENCY OR INDIVIDUAL WITHOUT THE EXPRESS WRITTEN PERMISSION OF THE OFFICE OF THE DIRECTOR, NATIONAL SECURITY AGENCY</p>
<p>SECRET</p>	<p>NO INFORMATION IS TO BE RELEASED FROM THIS DOCUMENT TO ANY OTHER AGENCY OR INDIVIDUAL WITHOUT THE EXPRESS WRITTEN PERMISSION OF THE OFFICE OF THE DIRECTOR, NATIONAL SECURITY AGENCY</p>
<p>SECRET</p>	<p>NO INFORMATION IS TO BE RELEASED FROM THIS DOCUMENT TO ANY OTHER AGENCY OR INDIVIDUAL WITHOUT THE EXPRESS WRITTEN PERMISSION OF THE OFFICE OF THE DIRECTOR, NATIONAL SECURITY AGENCY</p>
<p>SECRET</p>	<p>NO INFORMATION IS TO BE RELEASED FROM THIS DOCUMENT TO ANY OTHER AGENCY OR INDIVIDUAL WITHOUT THE EXPRESS WRITTEN PERMISSION OF THE OFFICE OF THE DIRECTOR, NATIONAL SECURITY AGENCY</p>
<p>SECRET</p>	<p>NO INFORMATION IS TO BE RELEASED FROM THIS DOCUMENT TO ANY OTHER AGENCY OR INDIVIDUAL WITHOUT THE EXPRESS WRITTEN PERMISSION OF THE OFFICE OF THE DIRECTOR, NATIONAL SECURITY AGENCY</p>
<p>SECRET</p>	<p>NO INFORMATION IS TO BE RELEASED FROM THIS DOCUMENT TO ANY OTHER AGENCY OR INDIVIDUAL WITHOUT THE EXPRESS WRITTEN PERMISSION OF THE OFFICE OF THE DIRECTOR, NATIONAL SECURITY AGENCY</p>
<p>SECRET</p>	<p>NO INFORMATION IS TO BE RELEASED FROM THIS DOCUMENT TO ANY OTHER AGENCY OR INDIVIDUAL WITHOUT THE EXPRESS WRITTEN PERMISSION OF THE OFFICE OF THE DIRECTOR, NATIONAL SECURITY AGENCY</p>
<p>SECRET</p>	<p>NO INFORMATION IS TO BE RELEASED FROM THIS DOCUMENT TO ANY OTHER AGENCY OR INDIVIDUAL WITHOUT THE EXPRESS WRITTEN PERMISSION OF THE OFFICE OF THE DIRECTOR, NATIONAL SECURITY AGENCY</p>
<p>SECRET</p>	<p>NO INFORMATION IS TO BE RELEASED FROM THIS DOCUMENT TO ANY OTHER AGENCY OR INDIVIDUAL WITHOUT THE EXPRESS WRITTEN PERMISSION OF THE OFFICE OF THE DIRECTOR, NATIONAL SECURITY AGENCY</p>
<p>SECRET</p>	<p>NO INFORMATION IS TO BE RELEASED FROM THIS DOCUMENT TO ANY OTHER AGENCY OR INDIVIDUAL WITHOUT THE EXPRESS WRITTEN PERMISSION OF THE OFFICE OF THE DIRECTOR, NATIONAL SECURITY AGENCY</p>
<p>SECRET</p>	<p>NO INFORMATION IS TO BE RELEASED FROM THIS DOCUMENT TO ANY OTHER AGENCY OR INDIVIDUAL WITHOUT THE EXPRESS WRITTEN PERMISSION OF THE OFFICE OF THE DIRECTOR, NATIONAL SECURITY AGENCY</p>
<p>SECRET</p>	<p>NO INFORMATION IS TO BE RELEASED FROM THIS DOCUMENT TO ANY OTHER AGENCY OR INDIVIDUAL WITHOUT THE EXPRESS WRITTEN PERMISSION OF THE OFFICE OF THE DIRECTOR, NATIONAL SECURITY AGENCY</p>
<p>SECRET</p>	<p>NO INFORMATION IS TO BE RELEASED FROM THIS DOCUMENT TO ANY OTHER AGENCY OR INDIVIDUAL WITHOUT THE EXPRESS WRITTEN PERMISSION OF THE OFFICE OF THE DIRECTOR, NATIONAL SECURITY AGENCY</p>
<p>SECRET</p>	<p>NO INFORMATION IS TO BE RELEASED FROM THIS DOCUMENT TO ANY OTHER AGENCY OR INDIVIDUAL WITHOUT THE EXPRESS WRITTEN PERMISSION OF THE OFFICE OF THE DIRECTOR, NATIONAL SECURITY AGENCY</p>
<p>SECRET</p>	<p>NO INFORMATION IS TO BE RELEASED FROM THIS DOCUMENT TO ANY OTHER AGENCY OR INDIVIDUAL WITHOUT THE EXPRESS WRITTEN PERMISSION OF THE OFFICE OF THE DIRECTOR, NATIONAL SECURITY AGENCY</p>
<p>SECRET</p>	<p>NO INFORMATION IS TO BE RELEASED FROM THIS DOCUMENT TO ANY OTHER AGENCY OR INDIVIDUAL WITHOUT THE EXPRESS WRITTEN PERMISSION OF THE OFFICE OF THE DIRECTOR, NATIONAL SECURITY AGENCY</p>

Table of Contents

	Page
Abstract.	1
Background.	1
Test Specimen Description	4
Test Series Details	7
Series I Test Procedure, Improvements and Analysis	7
Series II Test Procedure, Improvements and Analysis.	8
Features Selected for Series III, IV and V	9
Series III Test Procedure, Improvements and Analysis	11
Series IV Test Procedure and Improvements.	14
Series V Test Procedure and Improvements	14
Composite Series	15
Metal to Composite Test Series	16
Status of Pattern Recognition Studies	17
Future Work and Concluding Remarks.	20
References.	22
 <u>List of Figures</u>	
Fig. 1 - Block Diagram of the Fast Ultrasonic Data Acquisition and Analysis System.	24
Fig. 2 - The Immersion Tank, Driving Step Motors, Ultrasonic Pulser, and Spectrum Analyzer used in the Automated Ultrasonic Scanning Procedure	25
Fig. 3 - The PDP11/05 Digital Computer, and Biomatron 8100 A to D Converter used to Control and Acquire the Ultrasonic Bond Echo Signal.	26
Fig. 4 - Step-Lap Joint Test Specimen (SI conversion: 25.4 mm = 1 in.)	27
Fig. 5 - Features Considered in the Adhesive Bond Inspection Sorting Study (Series I and II).	28

ACCESSION FOR	
NTIS	<input checked="" type="checkbox"/>
DCC	
UNANIMOUS	
JUSTIFICATION	
BY	
DISTRIBUTION/AVAIL.	
Dist.	AVAIL.
A	

Fig. 6 - Performance Characteristics of the Twelve Surface Preparation Adhesive Bond Specimens	29
Fig. 7 - Series I - The Two-Sided Adhesive Bond Inspection Sorting Study	30
Fig. 8 - Primary Sources of Noise in the Adhesive Bond Inspection Problem	31
Fig. 9 - Definition of the Feature	32
Fig. 10- Bond Inspection From Both Sides - Series II	33
Fig. 11- The Practical One Sided Ultrasonic Inspection Problem for Series II	34
Fig. 12- Collective Flow Chart of the Data Acquisition and Analysis Procedure	35
Fig. A1 - Sample PDF Curves for Feature 8 for the Two-Class Bond Inspection Problem in Series III	43
Fig. A2a - Sample Test Data for Specimen No. 79 - Good	45
Fig. A2b - Sample Test Data for Specimen No. 81 - Poor	46

List of Tables

Table I - Program of Study - Ultrasonic Procedures for the Determination of Bond Strength (Page 1 of 2)	36
Table I - Program of Study - Ultrasonic Procedures for the Determination of Bond Strength (Page 2 of 2)	37
Table II - NDT Values in the Material and Flaw Classification System Performance Potential Prediction Problem	38
Table III - A Proposed Simulearning Computation Procedure.	39
Table IV - Characteristics of the Twelve Adhesive Bond Specimens For Series I, II, and III	40
Table V - Series IV Specimen Performance Data.	41

Appendices

Appendix 1 - Sample Probability Density Function Curves	42
Appendix 2 - Sample Test Data.	44

Abstract

A completely automated ultrasonic inspection system has been developed at Drexel University for predicting bond strength in metal to metal adhesively bonded step-lap joints. Results to date appear promising for solving this difficult problem of predicting adhesive bond performance.

A resource base developed in earlier years in experimental technology, theoretical ultrasonic wave interaction studies with adhesive bond models, manufacturing technology, shear stress distribution analysis has been incorporated into a pattern recognition program of study. Such topics as nearest neighbor philosophy, fuzzy logic analysis, probability density function analysis, and adaptive search and learning techniques for linear and non-linear models are currently being investigated.

Background

Drexel University, as part of contract number 73-2480, is currently engaged in a research program in the development of ultrasonic procedures for the determination of bond strength. A five-year program of study is outlined in Table 1. Work tasks are being carried out to advance the state of the art in ultrasonic inspection for predicting adhesive bond performance in both metal to metal and metal to composite structures. Emphasis in the program is directed towards the bond strength problem and not that of locating and classifying de-bonding within an adhesively bonded joint. Rather than study the mechanics of bonding and the relationship with many of the manufacturing and service variables outlined in Reference [1], it is proposed to examine the potential of various ultrasonic signal features and their ability for predicting performance of an adhesively bonded structure. As indicated in Table 1, a substantial resource base in bond model analysis and experimental data acquisition techniques, has already been developed that allows us to move into the more advanced problems in adhesive bond strength prediction.

The overall philosophy of employing ultrasonic analysis in the adhesive bond inspection problem is illustrated in Table 2. The path labelled 1-2-3, as an example, shows how the theoretical modelling analysis was used in the overall program of study, providing us with improvements in data acquisition and analysis. Current work is directed towards the path 4-5 in an attempt to obtain some correlation between ultrasonic signal feature and performance of the structure. Path 6 is avoided because of the difficulty in flaw characterization, as well as extensions by way of fracture mechanics into the ultimate goal of the project; that of performance prediction.

Early work in the project, as indicated in References [1 and 2], provides us with a substantial resource base in understanding manufacturing parameters, thickness measurement, and shear stress distribution in a step-lap joint. Modelling concepts for studying ultrasonic wave interaction with adhesive bonds is reported in References [3, 4 and 5]. Promise for solving the difficult performance prediction problem is illustrated in Reference [6], where acid etch surface preparation on both sides of an adhesive bond is eliminated and performance and ultrasonic echoes are compared with a properly prepared adhesive bond specimen. In this particular case, the one feature of ultrasonic bond echo amplitude to upper surface reference amplitude provides us with a reasonable correlation for excellent and poor bonds. In this case, a 20 MHz transducer produced improved results compared to a 10 MHz transducer. Preliminary work in composite material analysis is reported in Reference [7], the work serving as an introductory study to problems associated with the ultrasonic examination of composite materials. Theoretical modelling of the effects of attenuation as a function of frequency on the physical modelling of adhesive bonds is reported in Reference [8], concepts of which may be extended to the metal to composite bonding problem in evaluating the masking effects of a composite material as an ultrasonic wave impinges on the interface from the metal side.

A fast data acquisition system, preliminary details of which are included in Reference [9], has been developed at Drexel University. A block diagram of the fast ultrasonic data acquisition and analysis system is illustrated in Fig. 1. Such work tasks as analog/digital converter interfacing, signal control interfacing, and specific software development programs have been carried out for the adhesive bond inspection program of study. A computer controlled scanning tank is illustrated in Fig. 2, followed by a photograph of our PDP 11/05 minicomputer system in Fig. 3.

Data acquisition and analysis principles are briefly outlined in a simulearning data analysis routine in Table 3. Although variations on the computation procedure presented in Table 3 are numerous, emphasis in the current adhesive bond data analysis program is focused on fuzzy logic procedures, nearest neighbor rule techniques, and several advanced aspects of pattern recognition. Basic philosophy of the approach is outlined in Table 3 when considered with a probability density function estimator for achieving threshold values in the fuzzy logic routine, prototype feature vectors required in the nearest neighbor rule algorithm development, and useful concepts of feature variation and interaction useful in many pattern recognition algorithms. Advanced concepts in pattern recognition combined with theoretical ultrasonic wave interaction model analysis are also being explored in the current work.

Test Specimen Description

Several series of test specimens have been fabricated for this study. A typical step-lap specimen is shown in Fig. 4. Two industrial adhesive systems, FM-47 and FM-73, from American Cyanamid Co. were used in this study. Manufacturing techniques for each adhesive system are illustrated in the following paragraphs.

Each substrate was machined from aluminum bar stock so that its finished dimensions were 6" X 1" X 1/2". A hole was drilled in the end of each half opposite the joint for mounting in an Instron testing machine for tensile strength evaluation. A one inch long step was cut into the other end providing a total bond area of one square inch with a nominal bond thickness of .01 inch for FM-47 specimens and .005 inch for FM-73 specimens.

Surface preparation of the adherends is the first step in adhesive bonding. It is important to clean thoroughly all surfaces which will be in contact with the adhesive. To accomplish this, the following procedure was followed: 1) The aluminum specimens were first wiped free of grease, oil, and dirt with acetone and then rinsed with tap water. 2) A test for water break was done at this point to determine surface contamination. The water usually beaded at this time, indicating need for further cleaning. 3) Specimens to be etched are then immersed in a chromic-sulfuric solution for ten minutes. 4) After ten minutes, the etched specimens are rinsed in cold tap water and soaked in cold de-ionized water for five minutes. During this step, the water break test will show a smooth continuous sheet of water over the etched areas. 5) Upon removal from the de-ionized water, the specimens are dried in the vented oven at 145°F. This cleaning procedure is the same for both FM-47 and FM-73 adhesives. In each series of specimens, surface treatment was varied by eliminating the acid etch from certain specimens.

After the specimens have dried, they are removed from the oven and allowed to cool to room temperature. After cooling, a thin layer of the appropriate primer is sprayed on the specimen surfaces which are to be in contact with the adhesive. For the FM-47 adhesive, the primer layer (FM-47 primer) should be .001 to .003 inches thick and for the FM-73, the primer layer (BR-127) should be .001 to .002 inches thick. The primer is first dried at room temperature, for two hours in the case of FM-47 and for thirty minutes in the case of BR-127. Then the specimens are placed in the vented oven to complete the primer cure cycle. The FM-47 primer is cured for sixty minutes at 230°F and the BR-127 primer is cured for thirty minutes at 250°F.

The actual bonding of the two aluminum half specimens is done in an autoclave. Both adhesives, FM-47 and FM-73, are manufactured in large sheets with a skrim. The sheets may be cut to the appropriate size and shape, in this case, one inch squares. The adhesive squares are placed on the bonding surfaces and the specimens are placed in a jig for curing. The specimens are then sealed in an acetate bag, placed in the autoclave, and attached to a vacuum line. A vacuum of 28 to 29 inches mercury is drawn on the bag as the temperature is increased. To cure FM-47, the specimens are heated to 280°F, at which point the autoclave is pressurized with nitrogen to obtain an effective bonding pressure of 100 psi. Heating is continued until the temperature reaches 300-335°F, and is held at that temperature for thirty minutes. The specimens are then allowed to cool to 210°F under full pressure. At 210°F, the pressure is released and the specimens are removed from the autoclave and allowed to cool.

FM-73 cure cycles need not be controlled as rigidly as those for FM-47. The following cure cycle chosen for this study is within the specifications outlined by American Cyanamid. After bagging, the specimens

are heated to 250°F within thirty minutes in the autoclave. The vacuum is drawn and autoclave pressure is applied until the effective bonding pressure is 40 ± 5 psi. The specimens are held at 250°F for sixty minutes and then allowed to cool to 200°F under pressure before they are removed from the autoclave.

After the specimens are removed from the jig, they are waterproofed by coating the bondline edges with polyurethane. This waterproofing is applied to eliminate the possibility of water affecting the bond during ultrasonic inspection in an immersion tank.

Test Series Details

Five series of metal to metal adhesively bonded test specimens have been fabricated, data analysis results of which are explained in the following sections. Conditions for each test series, results for the test series, and improvements for the following series are included in each section. In addition, a composite series and a metal to composite series is planned.

Test Series I - Test Procedure, Improvements, and Analysis:

1. A 10 mil-thick FM-47 commercially available adhesive was used with a 2024 T4 aluminum in preparing 12 bond specimens for this series. An acid etch surface preparation was either used or not used in an attempt to obtain a distribution of failure loads on which classification could be based. Characteristics of the 12 adhesive bond specimens used in Series I is outlined in Table 4.

2. A 10 MHz, 1/4 inch diameter non-focused, highly damped transducer was used for this test series with a 1 1/2" water path in a pulse-echo immersion test procedure.

3. A mechanically based feature extraction procedure from graphics output was undertaken with emphasis being placed on three nonlinear features of the amplitude-time and amplitude-frequency profiles. The features are defined in Fig. 5.

4. A 6-point data acquisition procedure was obtained over the total area of the adhesive bond being studied. This series, however, made use of only typical profiles obtained over all 6 locations in the bond.

5. A very crude visual acceptance criteria on the transducer was employed in this series.

6. The feature of peak-to-peak magnitude from the bondline divided by the front surface reference amplitude was not suitable for classification purposes even though this feature worked fairly well for specimens prepared

earlier in the test program, namely those with either both or no sides prepared with an acid etch. A higher frequency transducer may be needed to show the required separation.

7. A graph of quality rating vs. failure load presented in Fig. 6 shows that this typical industrial approach to the problem is not applicable because of the overlap in failure load for the various quality ratings. This approach does not work and is generally not a valid classification technique; in fact, to support this conclusion, data points for Series I, II, and III are all included in Fig. 6.

8. The only pattern recognition algorithm that seemed to classify this series reasonably well is outlined in the fuzzy logic sorting chart in Fig. 7. Inspection from both sides of the adhesive bond was necessary, and values obtained from both sides had to be considered in the sorting algorithm. Bonds were divided into two groups classified as either good or bad, failure loads of which can be obtained from Fig. 6.

Test Series II - Test Procedure, Improvements, and Analysis:

1. Noise Reduction - reduced attenuation in receiver amplifier and reduced sensitivity of Biomatron A/D converter (See Fig. 8).
2. Reference Echoes - to insure repeatability of input pulse.
3. Multiple Data Sets - spacial averaging was used in combination with shear distribution concept.
4. Improved signal to noise ratio was obtained through noise reduction.
5. Improved data analysis procedures.
6. Series I routine not effective.
7. A two-sided inspection algorithm based on α_1 average was developed, the feature of which is defined in Fig. 9. Results for the α_1 feature in predicting bond failure load are illustrated in Fig. 10, the approach of which is 100% effective if measurements are taken from both sides and

then a threshold value of α_1 average of approximately 130 separates the test specimens into two categories--excellent and poor--very nicely. If measurements are taken from one side of the bond only, the fuzzy logic chart shown in Fig. 11 may be followed. Values of α_1 less than 128 or greater than 168 classify the bonds as good or bad. However, complete separation cannot be made in the range $128 < \alpha_1 < 168$, causing some potentially good bonds to be classified as bad, since all unclassified specimens must be assumed to be bad. Possibly, with more data, this threshold region could be decreased in size to an acceptable level. Note that other features, for example α_2 , could reduce this number of unclassified specimens.

$$\alpha_2 = W_i \times (A6)_i = 2 \times (2 \text{ highest A6 measurements}) + 1 \times (2 \text{ lowest A6 measurements})$$

Features Selected for Series III, IV and V Data Sets

The data acquisition method used for the feature extraction determined 13 features from each point of the ultrasonic bond scan sequences. These features may be divided into two categories, one being the features extracted from the amplitude-time domain and the second, those features obtained from the amplitude-frequency domain. The features extracted from the amplitude-time domain were defined as follows:

PTP - The peak-to-peak pressure variation represents the maximum amplitude variation among adjacent lobes of the amplitude-time bond echo divided by the maximum pressure variation of the reference signal.

ARG - The activity region is a modification of the term pulse duration. To determine the activity region, a spline curve containing all the relative maximums of the rectified bond echo was found. Next, two points on the splined curve were located. They were the first and last points

having an amplitude equal to a threshold value 5% of PTP.

The difference in time of these points is the activity region.

ERAT - The area enclosed by the rectified amplitude-time bond echo within the activity region.

EAT - The ratio of positive to negative area enclosed by the amplitude-time bond echo within the activity region.

The remaining nine features were found by analysis of the amplitude-frequency domain. Since many of their definitions are dependent on one another, the features are defined in the order that the computer determined them.

The first parameter found by the computer is A_3 , the maximum amplitude of the Fourier spectrum. The computer next searches the Fourier spectrum to find a 6 dB point on each side of frequency location of A_3 . The difference between the 6 dB frequency locations is defined as the bandwidth of the bond echo. The number of relative maximums and minimums occurring within the bandwidth region of the spectrum is defined as the number of relative max. and min. Working outward from each 6 dB point, a number of relative minimums and/or maximums usually occur in the amplitude-frequency domain. The first relative minimum to the left of the left 6 dB point is A_2 . After passing A_2 and still proceeding towards zero, the first relative maximum found is A_1 . Similarly defined is A_4 and A_5 which are to the right of the right 6 dB point. A_4 is a relative minimum and A_5 is a relative maximum. If either A_1 , A_2 , A_4 , and A_5 are not found, they are assigned the value of the last Fourier amplitude analyzed while moving to the left or right of the respective 6 dB point. For example, if both A_1 and A_2 do not exist, then $A_1 = A_2 = C_{\text{begin}}$ where C_{begin} is the first Fourier coefficient in the search area. Thus, the remaining features may be defined as follows:

A_3/A_1 - the amplitude ratio of A_3 to A_1
 A_3/A_5 - the amplitude ratio of A_3 to A_5
 A_1/A_2 - the amplitude ratio of A_1 to A_2
 A_5/A_4 - the amplitude ratio of A_5 to A_4
FREQ2 - the frequency location of A_2
FREQ4 - the frequency location of A_4

NRMM - the number of relative maximum and minimum between
the 6 dB points on both sides of A_3
BDW - the difference in frequency between the right
6 dB point and the left 6 dB point
MDF - the average frequency of the two 6 dB points

Test Series III - Test Procedure, Improvements, and Analysis:

1. 12 test specimens were fabricated according to the guidelines established for Series I and Series II test specimens.
2. Because of the sensitivity of the ultrasonic echoes on the input signal to the adhesive bond, it was decided to try the fuzzy logic concept introduced in Series II as well as other algorithms in pattern recognition with an improved ultrasonic transducer incorporating more severe acceptance criteria for the test transducer. A 10 MHz broadband transducer tuned for smooth frequency characteristics was selected for the study.
3. Reference test data was obtained for all test points, hopefully allowing us to compare test results on different days, conducted by different operators, etc.
4. The probability density function estimator concept was introduced for this test series, [10,11], the PDF being useful in fuzzy logic determination and in prototype selection for various algorithms in pattern recognition. See Appendix 1 for sample results.

5. Computerized feature extraction was introduced, the specific features and definitions of which have been outlined in the previous section. Sample test data is shown in Appendix 2.

6. The Series II fuzzy logic sorting algorithm was not applicable for this test series, probably because of threshold value dependence on pulse parameters, the threshold values being important in the fuzzy logic sequence.

7. A complete data analysis routine is illustrated in Fig. 12. Time averaging of the amplitude versus time profiles is accomplished by a spline fit computer program. Background on the spline function and its capability is illustrated in Reference 12. The spacial shear averaging was accomplished by designating a weight 2 to the edges of the shear joint and a weight 1 to the center portion.

8. Several approaches to pattern recognition were considered in this study. A brief description is presented below. A series of probability density estimator curves were run on each feature to determine which features might be suitable for separating the data. It was found that although some features looked promising when run for each class--good and bad--separately, it was impossible to set threshold values to yield good separation. These results indicated that there is an interaction between features that cannot be defined without more advanced pattern recognition algorithms.

In performing a two class problem, the specimens were grouped such that those failing above 2500 lbs. were Class I and those below 2500 lbs. were Class 2. Prototype feature vectors were formed using the mean value of each feature over all of the data for each class. The low index of performance on this self test indicates that additional sophistication in the pattern recognition algorithm is required. A further attempt to solve the two class problem using weight selection was unsuccessful indicating that the two classes were not linearly separable.

Because one of the goals of this study is one sided classification, that is classification of the bond using data from only one side, it was decided to expand the problem to a four class problem. A four class system is physically motivated by the fact that weak bonds may fail at a low load due to a problem at either the top or bottom adhesive-adherend interface, or at both interfaces. These differences would show up in the ultrasonic echo, but not necessarily in the failure load data. In addition, good bonds which fail at high loads may produce varied ultrasonic responses. For these reasons, the specimens were grouped in four classes, two good and two bad. The index of performance for this four class problem, shown in Table 4, is extremely low using the minimum distance classifier. A linear discriminant function using weighting factors was sought but proper weights could not be established, indicating that the data is not linearly separable into four classes.

A thirteen class problem was then attempted using the linear discriminant algorithm. In this case, each bond specimen represented one class. Weights were established using half of the data available and then a test was run using the remaining data. Index of performance figures were high. Although the test is unrealistic from an engineering viewpoint, hope is established in the separability of the data.

The two class problem was then attempted using two adaptive learning procedures. A linear first order technique using the eight best features chosen by physical motivation and probability density function variations was attempted. In this case, weights for each feature were chosen by the operator in an iterative process looking for the highest index of performance. Final results were poor, resulting in an index of performance of about 60%.

The second adaptive learning procedure to be used considered non-linear combinations of sets of features. In this technique, the performance of combinations of two features is evaluated to find the combinations yielding the lowest error. Then, those sets of features chosen are combined in the same way in a layering sequence. After two layers, index of performance values as high as 90% were obtained.

Test Series IV - Test Procedure and Improvements:

1. A more recently available adhesive, FM-73, was chosen because of its current wide use in Air Force programs.
2. Twenty-four specimens were fabricated in the same manner as previous series, using the acid etch to control the quality of the bond. In addition, specimen numbers 45 through 48 were exposed to contaminants before bonding.
3. Failure load data was grouped into more classes to yield a prediction procedure having more engineering significance. A list of the failure loads for Series IV specimens is shown in Table 5.
4. Advanced techniques in pattern recognition will be considered in this analysis.

Test Series V - Test Procedure and Improvements:

1. Plans call for this test series of twenty-four specimens (48 test situations) to be a test set completely, in testing the algorithms developed for Series IV.

Composite Series

1. Ultrasonic examination of several composite material test specimens is being carried out in our laboratory as a pilot inspection program for the more difficult metal to composite adhesive bond inspection program. Specimens available are listed below:

PILOT COMPOSITE MATERIAL INSPECTION PROGRAM

(to examine possible attenuation or dispersion effects associated with metal to composite bond inspection and also for moisture absorption inspection control)

Graphite Epoxy Panel Specimens Available

<u>Quantity</u>	<u>Ply</u>	<u>Orientation</u>	<u>Size</u>	
20	8	90°	3x3	} Proper Cure
15	8	90°	3x3	
5	8	[0,+45,90]	3x3	
5	8	[0,90]	3x3	
2	16	[0,90]	3x3	
2	16	[0,+45,90]	3x3	
2	16	90°	3x3	

plus 2 of each with improper cure

3501/AS1-5 - Hercules 3 inch wide prepreg tape using a standard type Grumman cure cycle.

2. Advanced aspects of the shear stress distribution and its value in pattern recognition is being investigated.

3. Series IV and V metal to metal adhesive bond test specimens are currently being tested and analyzed.

4. Pattern recognition techniques will be used in this study to examine both composite classification and natural clustering of the data sets. New features will be evaluated in addition to the ones described for the metal to metal work.

Metal to Composite Series

A specimen fabrication program is being planned that will incorporate many of the experimental and data analysis techniques developed in the metal to metal work and in the composite work.

Status of Pattern Recognition Studies

Several different approaches in pattern recognition were considered in this program of study. A brief summary of principle observations for several techniques is outlined in the following paragraphs:

1. Fuzzy Logic Technique.

Fuzzy logic procedures similar to those considered in Series I and II analysis have been evaluated for the Series III test data. In summary, the approach is certainly useful, but unfortunately, in the kind of adhesive bond test specimens considered in this program, leaves too many unclassified test situations. The concept may be explored in the future if found necessary for this kind of adhesive bond inspection problem. Technique depends quite strongly on accurate threshold values which can be obtained quite reliably if sufficient data is available to form a reasonable probability density function curve. [See Reference 13 for another example in fuzzy logic].

2. Nearest Neighbor Rule (Minimum Distance Classification).

This standard technique in pattern recognition was considered for Series III test specimens, designated as either excellent or poor, including various normalization techniques along with weighted and unweighted feature vectors, produced an index of performance of approximately 55%. This approach is definitely being eliminated from the algorithms considered in this program. Apparently the nature of the good and bad bonds is such that natural clustering does not occur in two classes, but may perhaps occur in six, seven, etc. classes because of the physical differences that can occur from one bond to another, particularly in the poor bond classification. A poor bond can come about from undercure, surface preparation from one side or another, fingerprints, etc., producing, therefore, a variety of amplitude-time and amplitude-frequency signatures even though failure loads are grouped very tightly.

The minimum distance classification scheme was also considered for a 13-class problem in Series III. Of 26 different test situations, counting inspection from both sides as two separate specimens, but in this case as one class, produced an index of performance of 97% when randomly dividing the data base into training and test situations. Although promising, the 13-class problem is unrealistic since too many classes are involved. The approach does provide hope, however, if the number of test specimens could increase to two, three or four times the number of classes considered in the study. Further work in this rather basic technique may be considered if necessary.

A four-class problem was also studied that consisted of two categories of poor and two categories of excellent, this approach being considered to incorporate the physical differences that could occur within a given class. Unfortunately, this predetermined number of class problem did not produce any reasonable index of performance values, the values being approximately 60%. Several examples of the use of weights and the minimum distance classifier are found in References 14 and 15.

3. Linear First-Order Adaptive Learning Network.

This approach was introduced to simplify our visual interpretation of clustering of certain features; as an example, of the 13 features used in the study, the eight best were selected. The selection criteria being both physically and statistically based by examining the probability density function variations of certain features. The eight features were then combined in a linear fashion as follows:

$$y_1 = a_1 x_1 + a_2 x_2 + a_3 x_3$$

$$y_2 = a_4 x_4 + a_5 x_5 + a_6 x_6 + a_7 x_7 + a_8 x_8$$

where x_1 , x_2 and x_3 were amplitude-time features and x_4 through x_8 were amplitude-frequency features, the a's being coefficients to be determined by adjustment. Basically, this approach provided us with two modified features, y_1 and y_2 , of which a good prototype and a poor prototype could be calculated. This allowed us to examine natural clustering in a two-dimensional feature space. Adjusting the a's provided us with improvements in index of performance values. This approach was not very successful, providing us with an index of performance of 60%, and a probability of locating poor specimens of 72%. This approach may be considered further in future work if adhesive bond model analysis of ultrasonic wave interaction mechanisms with various poor bond situations provides us with feature interaction appreciation. If so, adjusting the a's with an inverse feature or with a produce of two features could prove worthwhile.

4. Adaptive Non-Linear Learning Network.

A layered machine similar to the type described by Mucciardi [16 and 17] has also been considered in this program of study. Best results for this preliminary study involved feature numbers 1 and 4 as one set and 3 and 9 as a second combination. These two sets were combined in the second layer providing for us an index of performance of 90% for Series III. All of the test data was randomly divided into two sets; one for training and one for testing. Combinations of two features were considered for producing the best index of performance value in the 1st layer, x_1 and x_2 the two features considered.

$$y = a_1 x_1 + a_2 x_2 + a_3 x_1^2 + a_4 x_2^2 + a_5 x_1 x_2 + a_6$$

Additional work will be carried out that will certainly improve the index of performance values when including additional layers of this learning machine.

Future Work and Concluding Remarks

1. Careful experimentation and knowledge of ultrasonic wave propagation parameters is definitely critical. In addition, a test sequence should be planned carefully to reduce the water absorption effects on various ultrasonic measurement parameters.

2. Substantial progress has been made in developing a sound resource base in model analysis, data acquisition, weighting shear factors for non-uniform bonds, and signal processing for advancing the state of the art in ultrasonic inspection of adhesive bonds.

3. Promise for solving the difficult problem of predicting adhesive bond performance has been demonstrated in the feasibility study of the surface preparation problem in an aluminum-FM-47-aluminum step-lap system. Additional work in pattern recognition analysis, however, is certainly required.

4. Correlation of ultrasonic signal processing parameters with performance is definitely of greater value than correlation with programmed flaws in a bonded system.

5. There exists a need to utilize a fast data acquisition system and to develop computationally efficient algorithms in pattern recognition that could be used to solve some of the more difficult problems in adhesive bonded systems of practical value to the U.S. Air Force.

6. Additional work will be carried out to examine feature interaction and development of advanced algorithms in pattern recognition, several details of which were presented in an earlier section of the report.

7. The principle benefit to be gained from using the adaptive learning networks described earlier is the ability to determine significant feature interactions and, therefore, develop a greater physical understanding of the problem. Additional model analysis may then be done with the particular feature interactions in mind. Secondly, the adaptive learning networks may provide us with solutions to the bonding problem for the particular geometry and adhesive-substrate system chosen.

8. A comprehensive reference check is required to insure that acceptable ultrasonic data is indeed collected at any given time. The point-by-point reference check made in our system is sufficient to guarantee the go - no-go criteria.

9. Note that the six point scanning procedure used is an attempt to obtain an overall picture of the quality of the bond in question. Actually, complete coverage of the bond area is required, possibly with a focused transducer, if single point failure initiation locations need to be found. At present, our procedure is designed to find the overall crack formation resistance of the bond area.

10. The problem of cohesive strength prediction appears to be more easily solved than the adhesive strength prediction problem. In the cohesive problem, more easily understood mechanical properties of the adhesive are affected by parameters affecting cohesive strength. This problem will be addressed later through studies of wave speed and attenuation variations in the adhesive itself.

11. Series IV, Series V, Composite Series and Metal to Composite Series described earlier will be studied during the next year's work.

References

1. Rose, J.L. and Meyer, P.A., "Ultrasonic Procedures for Predicting Adhesive Bond Strength", Materials Evaluation, June 1973.
2. Rose, J.L. and Meyer, P.A., "Ultrasonic Signal-Processing Concepts for Measuring the Thickness of Thin Layers", Materials Evaluation, November 1973.
3. Rose, J.L. and Meyer, P.A., "AFOSR Interim Scientific Report - Ultrasonic Procedures for the Determination of Bond Strength", AFOSR-73-2480, (AFOSR TR 74-0779).
4. Rose, J.L. and Meyer, P.A., "AFOSR Interim Scientific Report - Ultrasonic Procedures for the Determination of Bond Strength", AFOSR-73-2480A, (AFOSR TR-75-0672).
5. Rose, J.L. and Meyer, P.A., "Modeling Concepts for Studying Ultrasonic Wave Interaction With Adhesive Bonds", Journal of Adhesion, Vol.8, pp. 107-120.
6. Meyer, P.A. and Rose, J.L., "Ultrasonic Determination of Bond Strength Due to Surface Preparation Variations in an Aluminum-To-Aluminum Adhesive Bond System", Journal of Adhesion, Vol.8, pp. 145-153.
7. Rose, J.L. and Shelton, W., "Damage Analysis in Composite Materials", American Society for Testing and Materials, 1975.
8. Meyer, P.A. and Rose, J.L., "Ultrasonic Attenuation Effects Associated With The Physical Modeling of Adhesive Bonds", Journal of Applied Physics, March 1977.
9. Rose, J.L., "AFOSR Interim Scientific Report - Ultrasonic Procedures for the Determination of Bond Strength", AFOSR-73-2480B.
10. Watanabe, S., Frontiers of Pattern Recognition, Academic Press, Inc., New York and London (1972).
11. Loftsgaarden, D.O. and Quesenberry, C.P., "A Non-Parametric Estimate of a Multivariate Density Function," Ann. Math. Statist., Vol. 38, pp. 1261-1265 (1965).
12. Theory and Applications of Spline Functions, Edited by T.N.E. Greville, Proceedings of an Advanced Seminar Conducted by the Mathematics Research Center, United States Army, at the University of Wisconsin, Madison, October 7-9, 1968, Academic Press, New York, San Francisco, London, (1969).
13. Rose, Joseph L. et al, "Flaw Classification Techniques in Ultrasonic Inspection," presented and published in the proceedings of the Eighth World Conference on Nondestructive Testing, Cannes, France, Sept. 1976.

14. Andrews, Harry C., Introduction to Mathematical Techniques in Pattern Recognition, Wiley Interscience, 1972.
15. Duda and Hart, Pattern Classification and Scene Analysis, Wiley Interscience, 1973.
16. Mucciardi, Anthony N. et al, "Adaptive Nonlinear Signal Processing for Characterization of Ultrasonic NDE Waveforms," Task 1, Inference of Flat-Bottom Hole Size, United States Air Force Materials Laboratory, Air Force Systems Command, Wright-Patterson AFB, Ohio, by Adaptronics, Inc., McLean, Virginia, January 1975.
17. Mucciardi, Anthony N. et al, "Adaptive Nonlinear Signal Processing for Characterization of Ultrasonic NDE Waveforms," Task 2, Measurement of Subsurface Fatigue Crack Size, United States Air Force Materials Laboratory, Air Force Systems Command, Wright-Patterson AFB, Ohio, by Adaptronics, Inc., McLean, Virginia, April 1976. Technical Report AFML-TR-76-44.

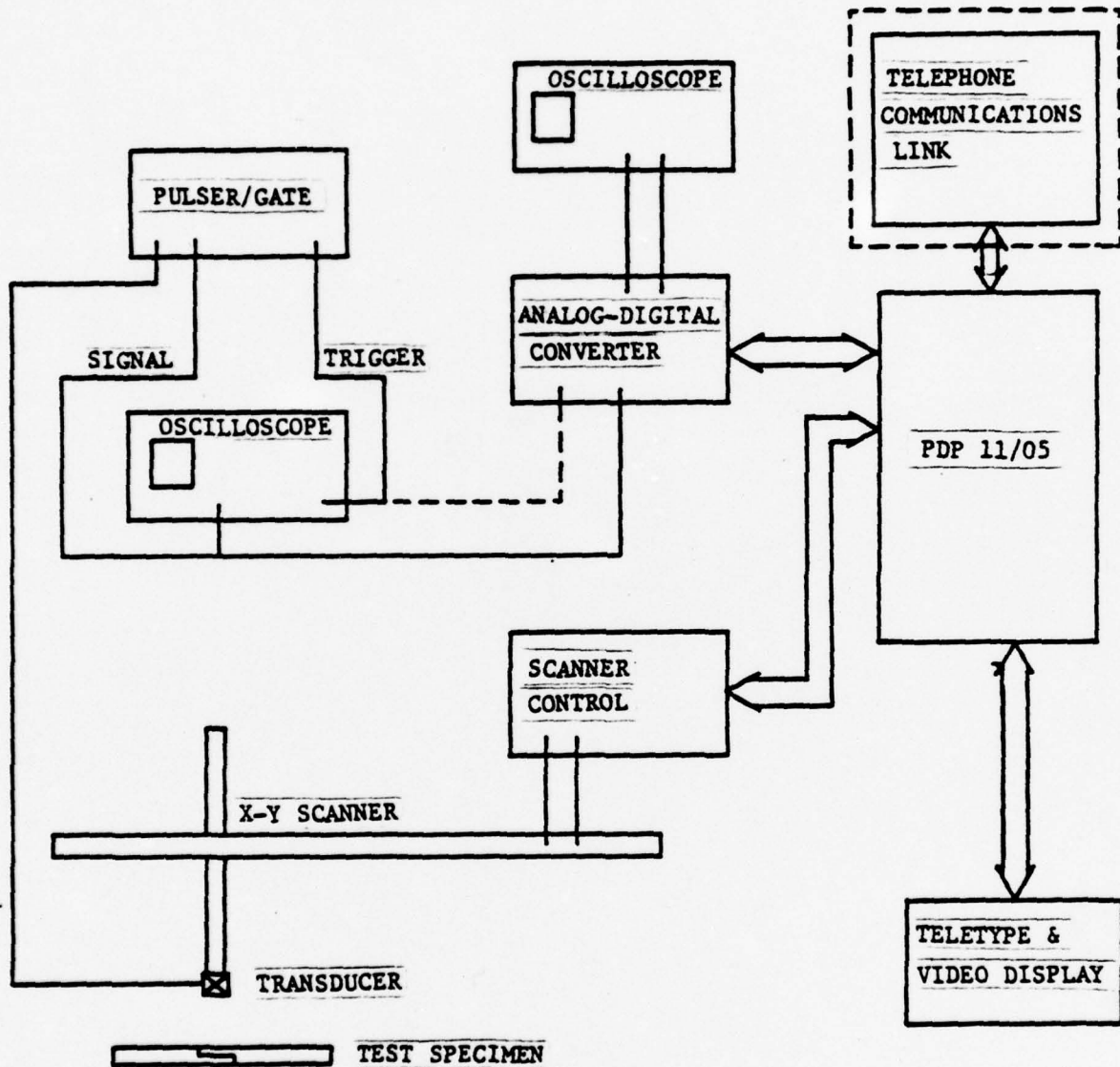

FIG. 1 - BLOCK DIAGRAM OF THE FAST ULTRASONIC DATA ACQUISITION AND ANALYSIS SYSTEM

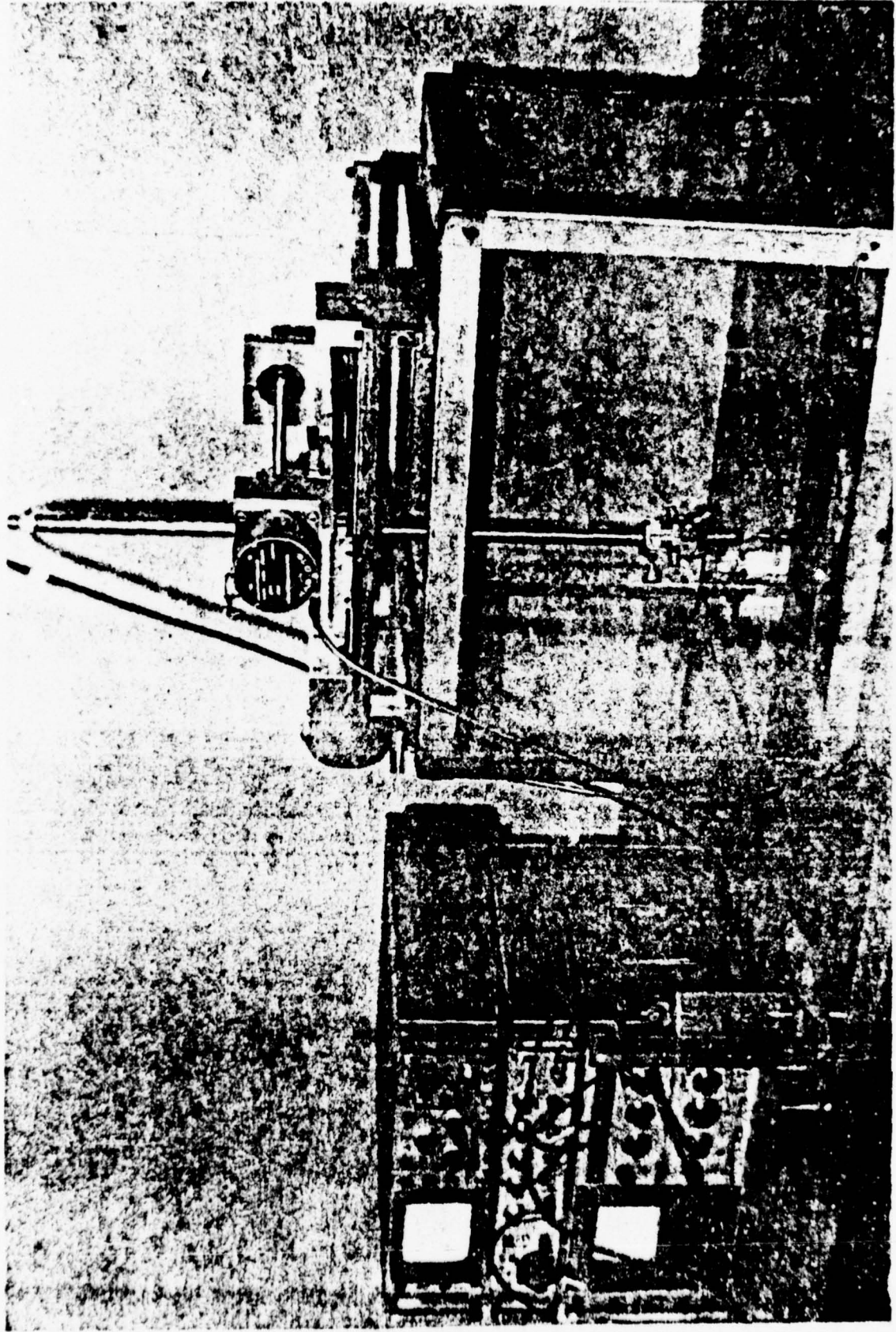

FIG. 2 - THE IMMERSION TANK, DRIVING STEP MOTORS, ULTRASONIC PULSER,
AND SPECTRUM ANALYZER USED IN THE AUTOMATED ULTRASONIC
SCANNING PROCEDURE

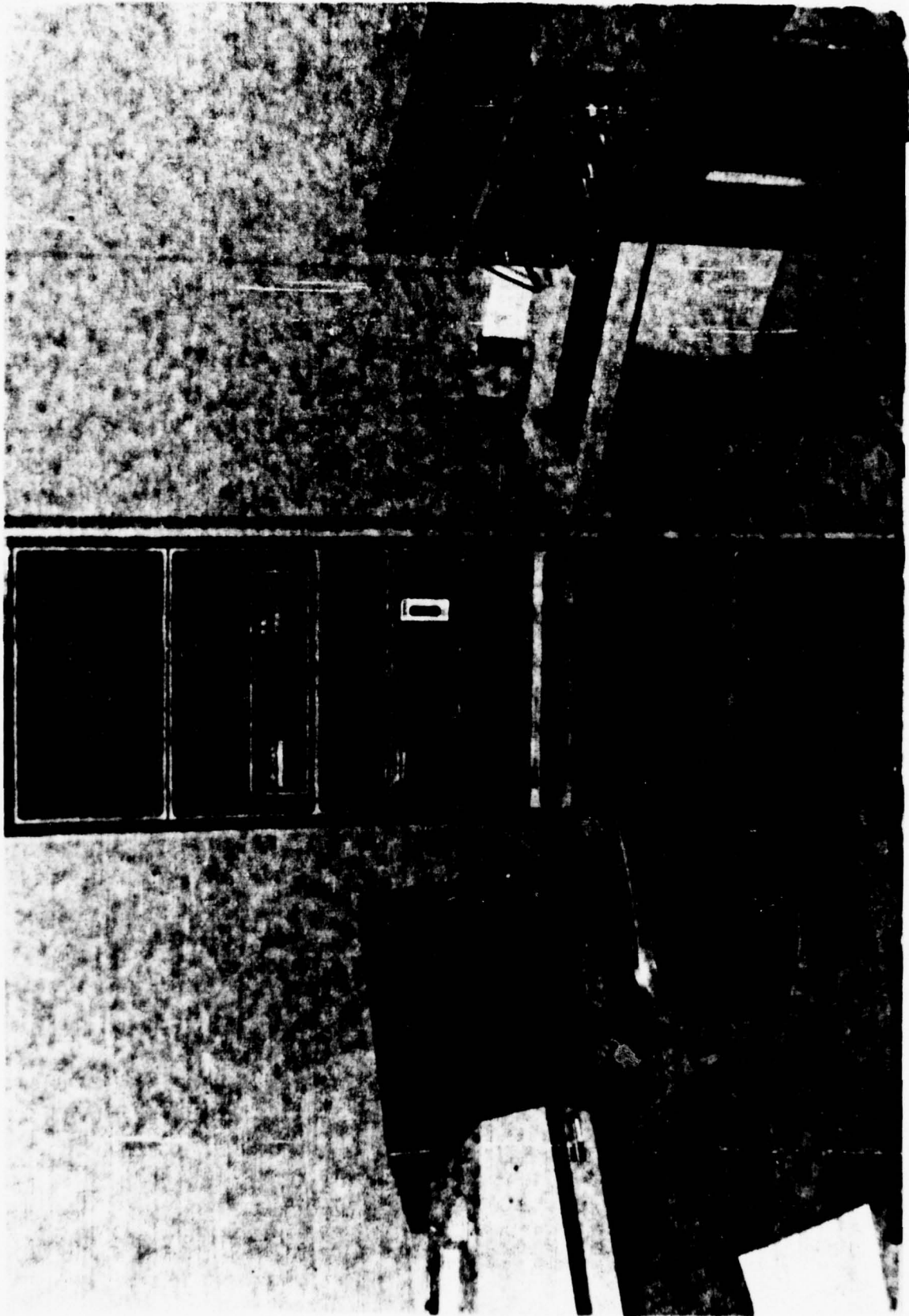
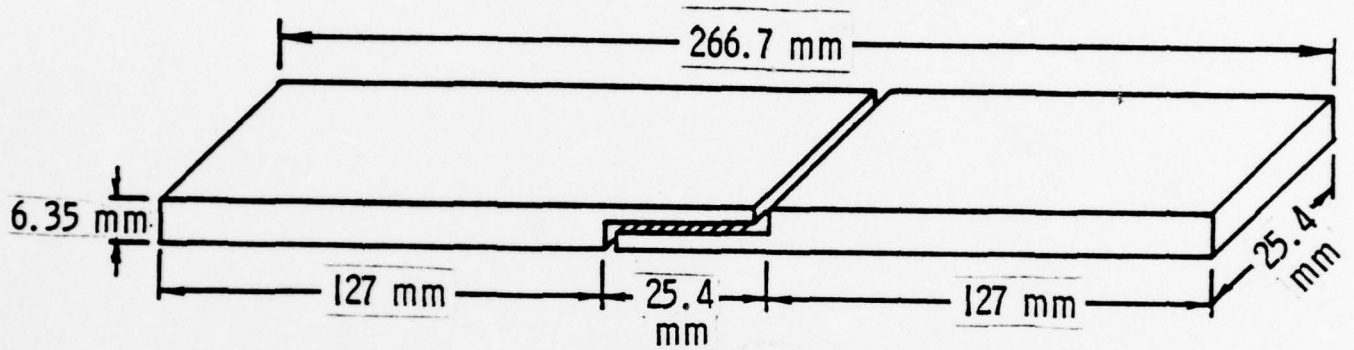
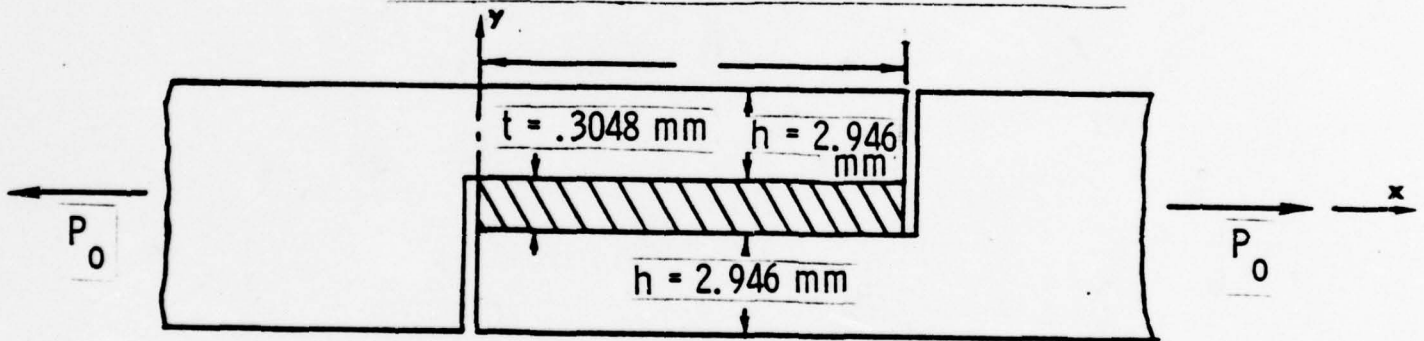

FIG. 3 - THE PDP 11/05 DIGITAL COMPUTER AND BIOMATION 8100 A/D CONVERTER
USED TO CONTROL AND ACQUIRE THE ULTRASONIC BOND ECHO SIGNAL



a - Metal to Metal Adhesive Step-Lap Joint



b - Bondline Detail

FIG. 4 - STEP-LAP JOINT TEST SPECIMEN (SI conversion: 25.4 mm = 1 in.)

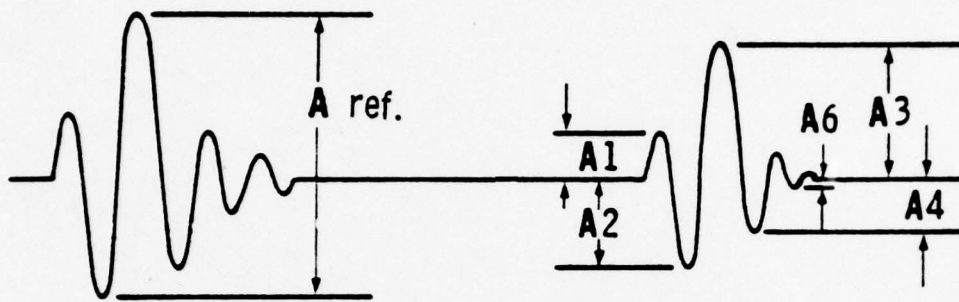

$$P.P. = \frac{A3 + \text{the maximum of either } A2 \text{ or } A4}{A \text{ ref.}}$$

N.D. = the number of discontinuities in the amplitude vs. frequency curve in the interval 5-10 MHz (could also be α decay, number of lobes, etc.)

$A2/A4$ = amplitude ratio of the magnitude A2 over A4

FIG. 5 - FEATURES CONSIDERED IN THE ADHESIVE BOND INSPECTION SORTING STUDY (SERIES I AND II)

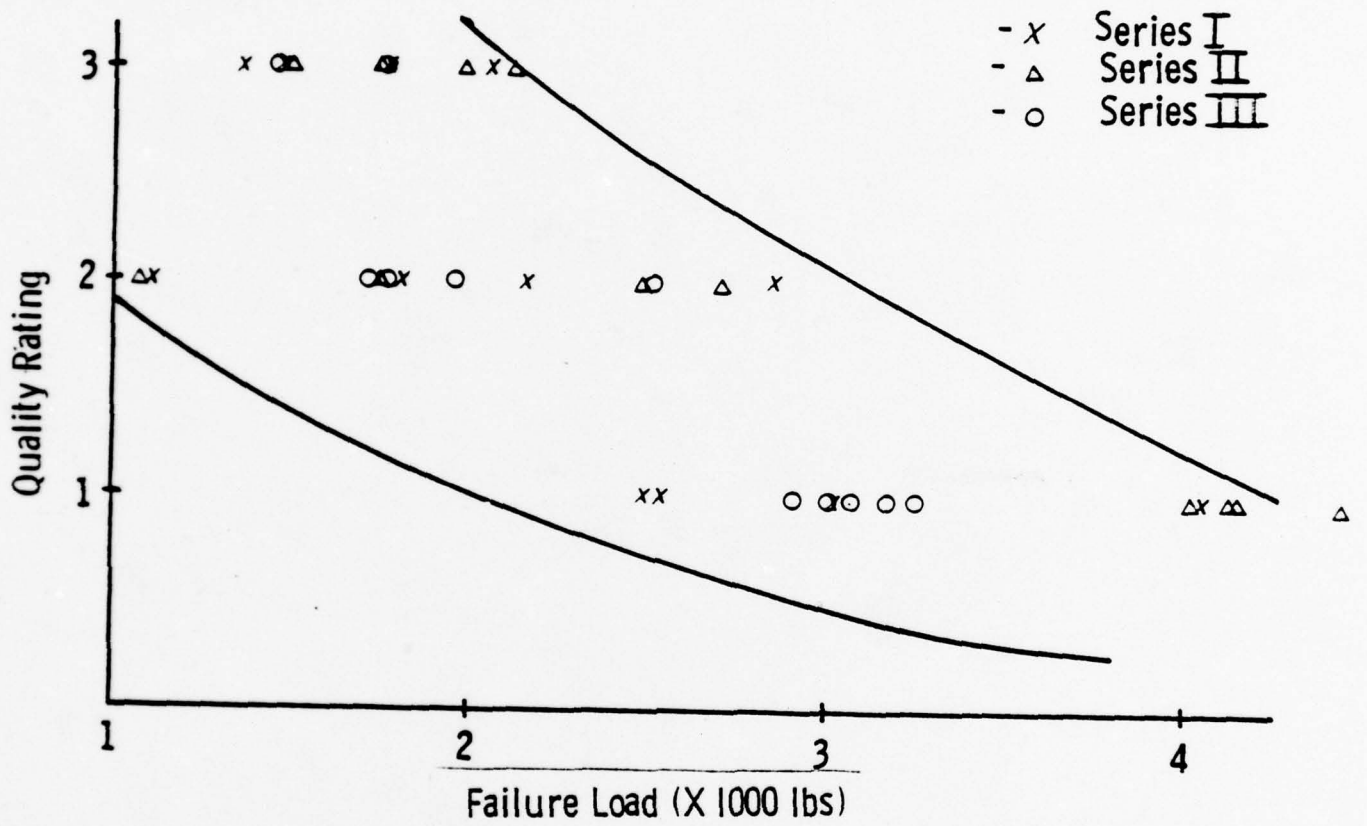

FIG. 6 - PERFORMANCE CHARACTERISTICS OF THE TWELVE SURFACE PREPARATION ADHESIVE BOND SPECIMENS

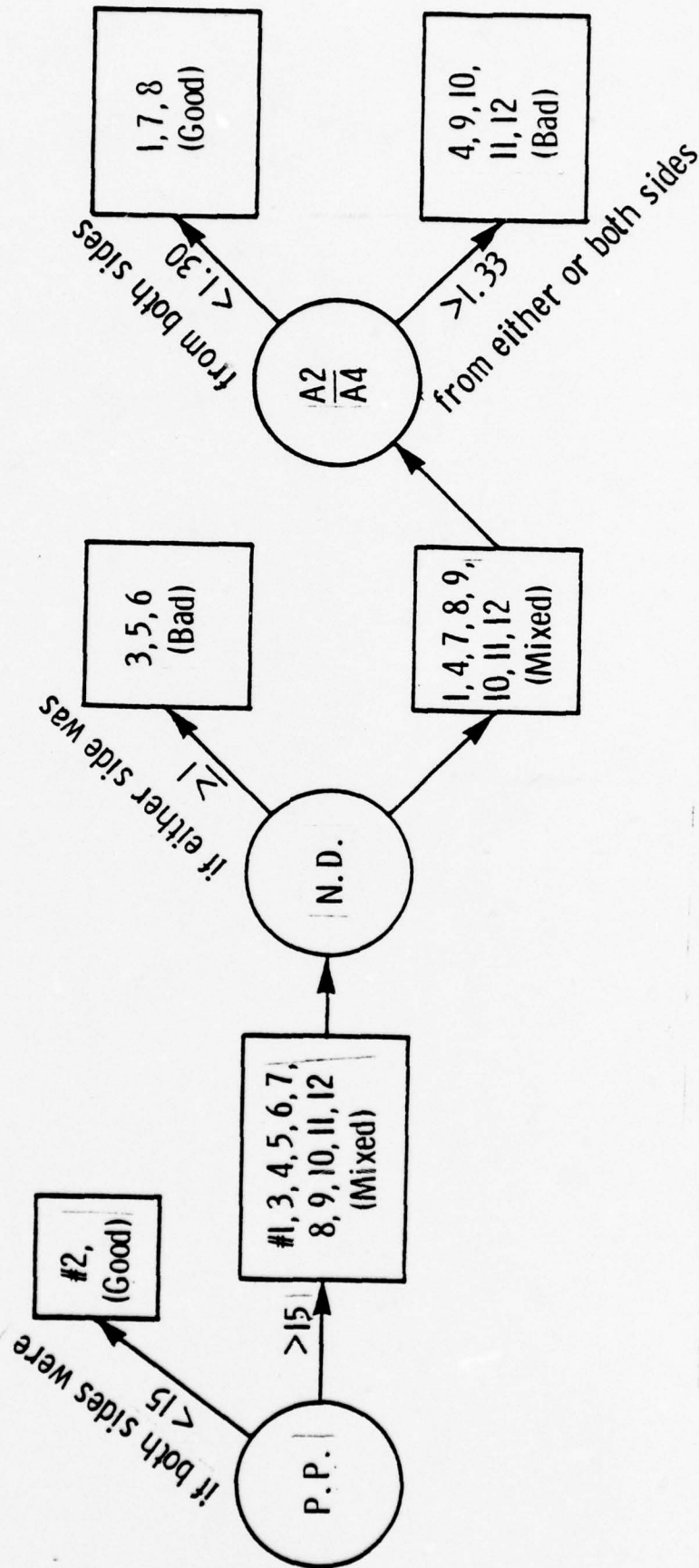

FIG. 7 - SERIES I-THE 2-SIDED ADHESIVE BOND INSPECTION SORTING STUDY

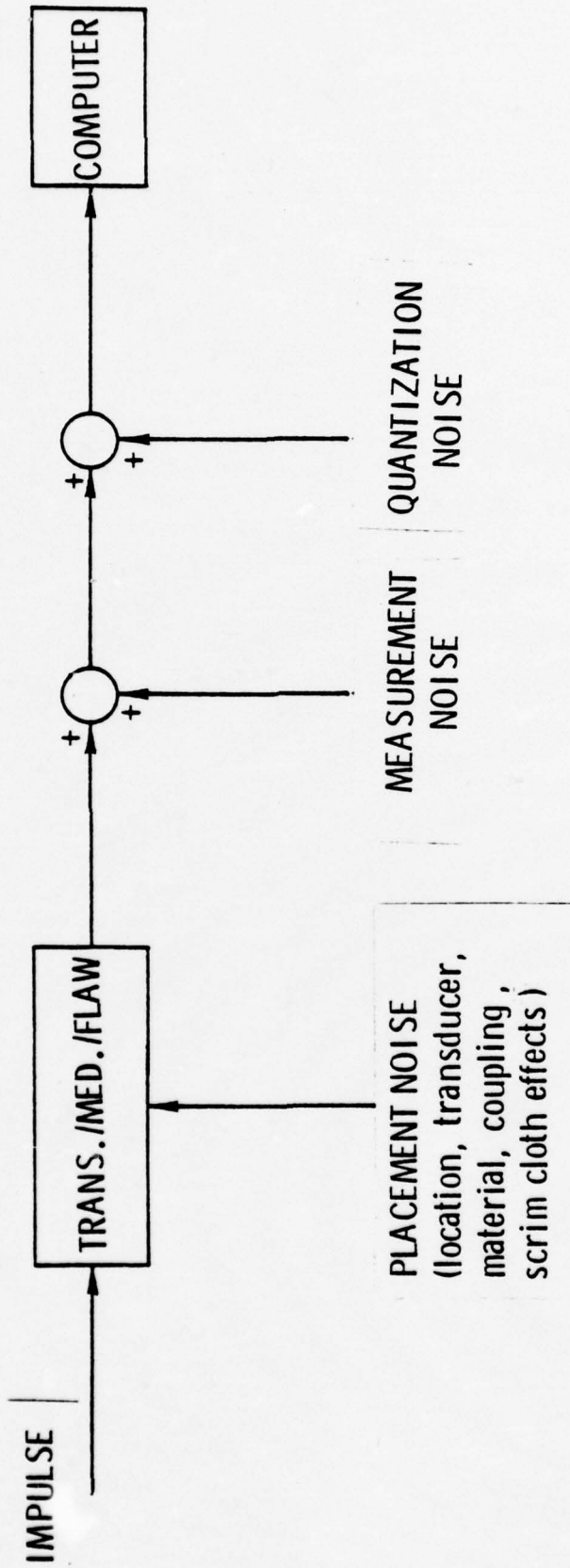

FIG. 8 - PRIMARY SOURCES OF NOISE IN THE ADHESIVE BOND INSPECTION PROBLEM

$$\alpha_1 = \omega_i \times (A_6)_i \times \left(\frac{A_2 + A_3}{10} \right)$$

WHERE $\omega_i = 5$ if highest A_6 values are in positions 6 and 1 or 3 and 4.

= 4 if highest A_6 values are on opposite sides of the bond.

= 2 for the two lowest values of A_6 (at positions 1, 6, 3 and 4).

= 1 for measurements at positions 2 and 5.

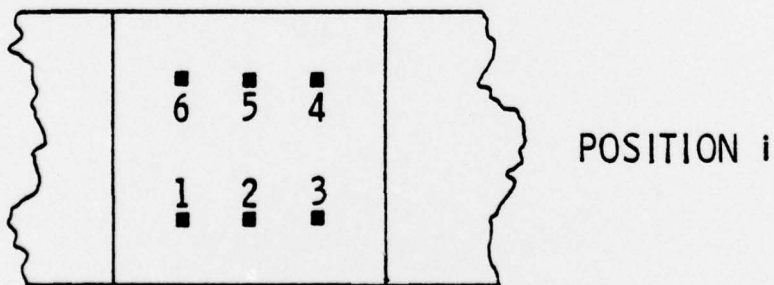

FIG. 9 - DEFINITION OF THE FEATURE α_1

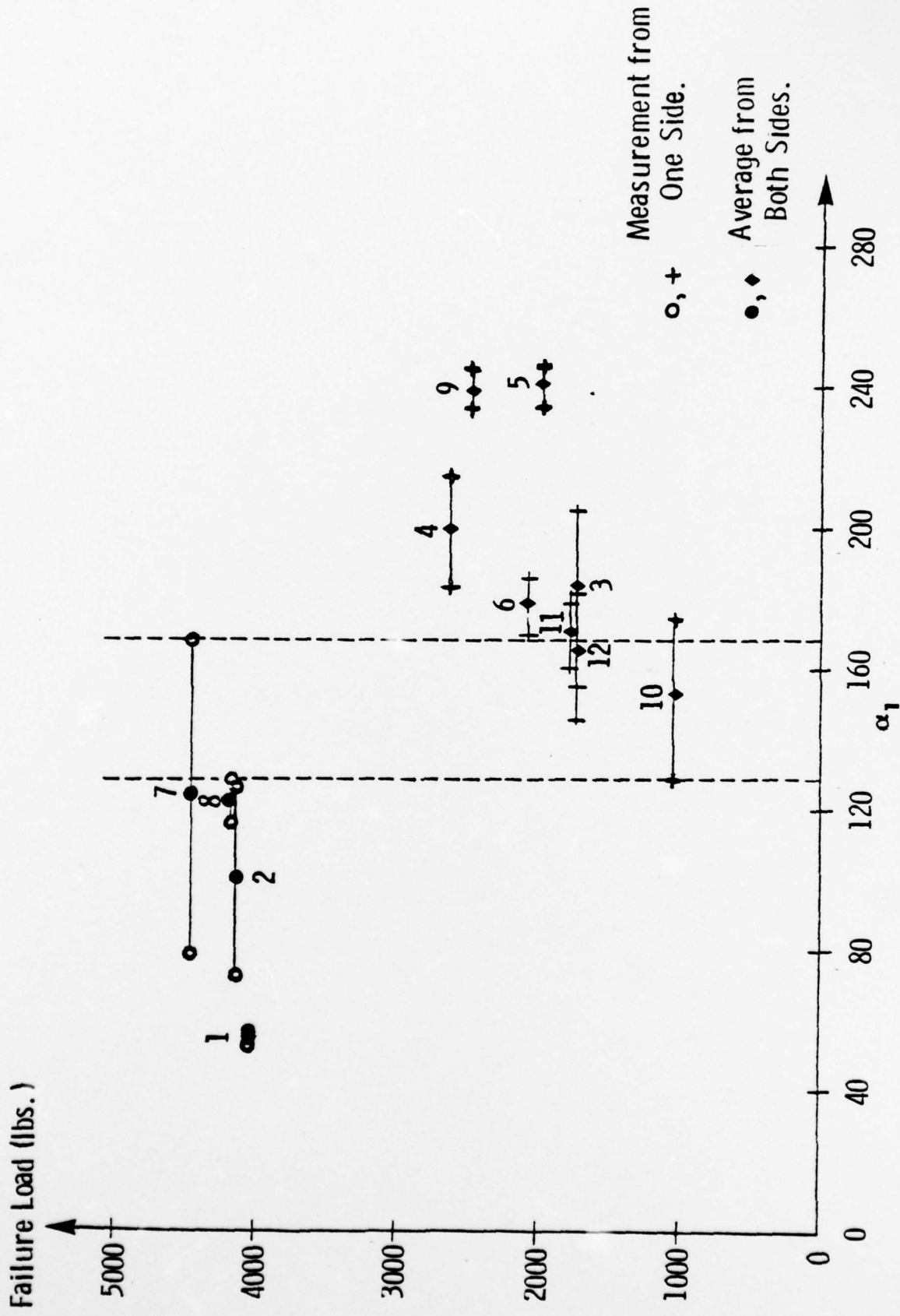

FIG. 10 - BOND INSPECTION FROM BOTH SIDES - SERIES II

Series II - Equivalent to 24 Specimens
For All Practical Purposes

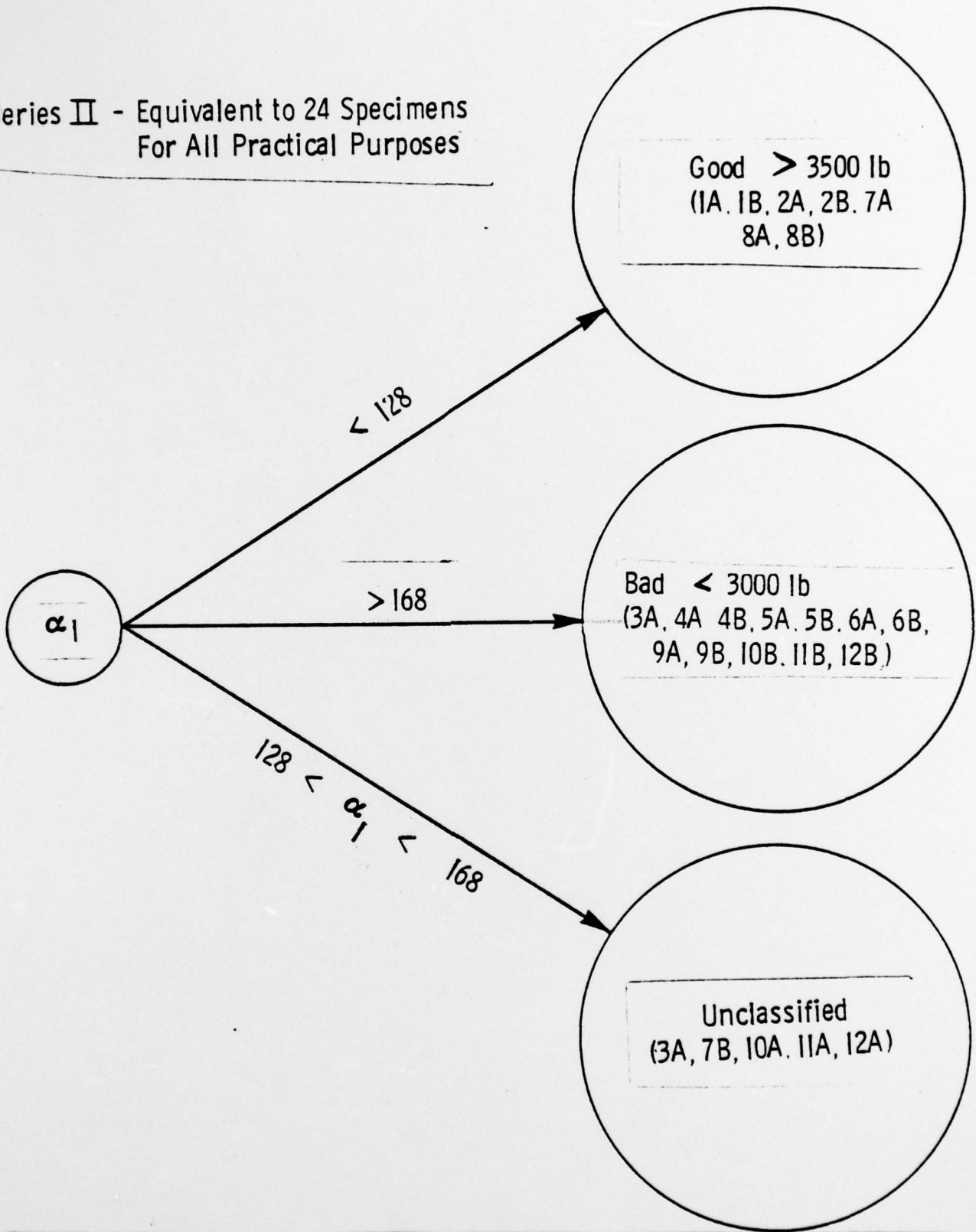

FIG. II - THE PRACTICAL ONE SIDED ULTRASONIC INSPECTION PROBLEM
FOR SERIES II

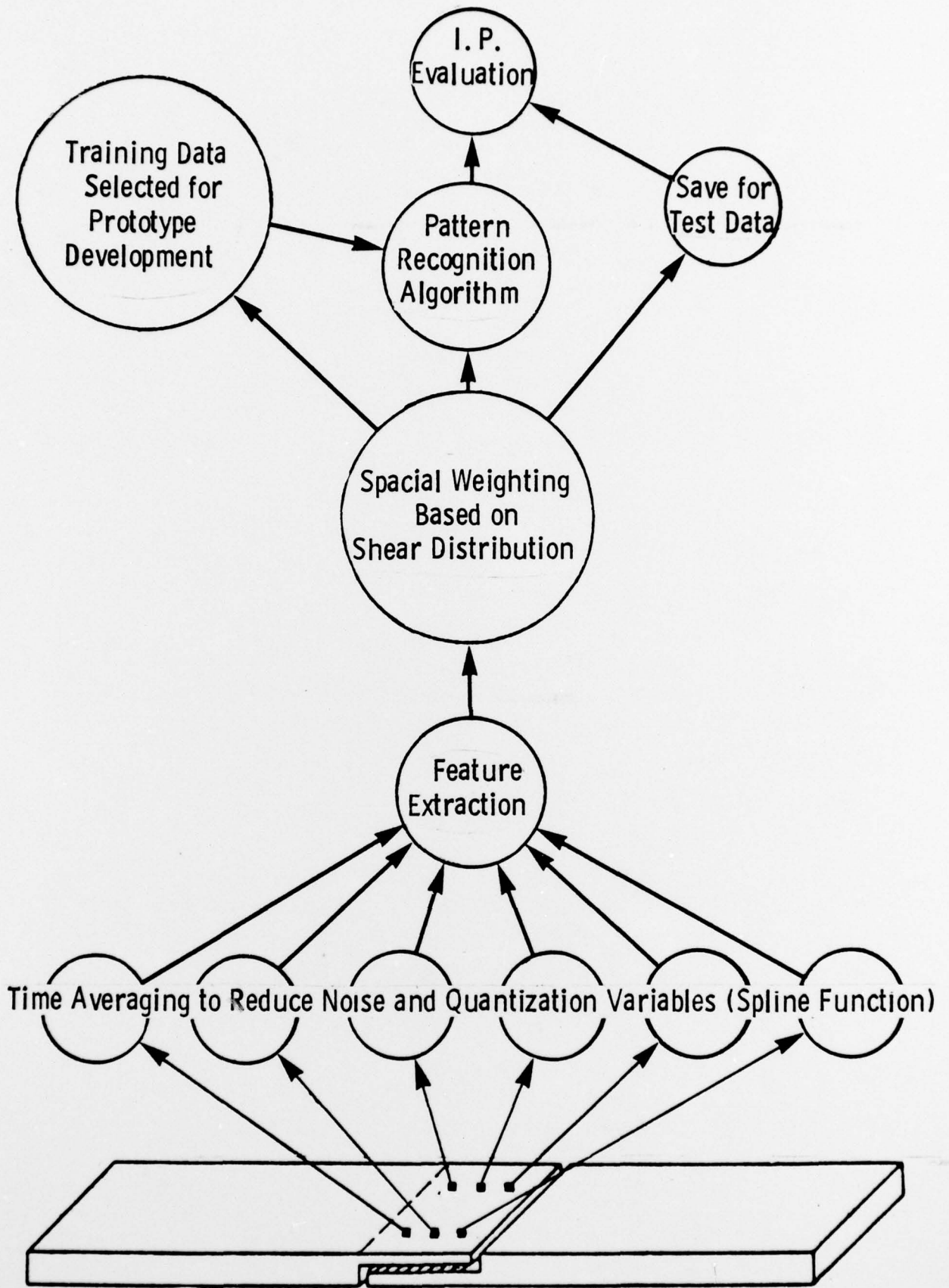

FIG. 12 - COLLECTIVE FLOW CHART OF THE DATA ACQUISITION AND ANALYSIS PROCEDURE

PREVIOUS WORK

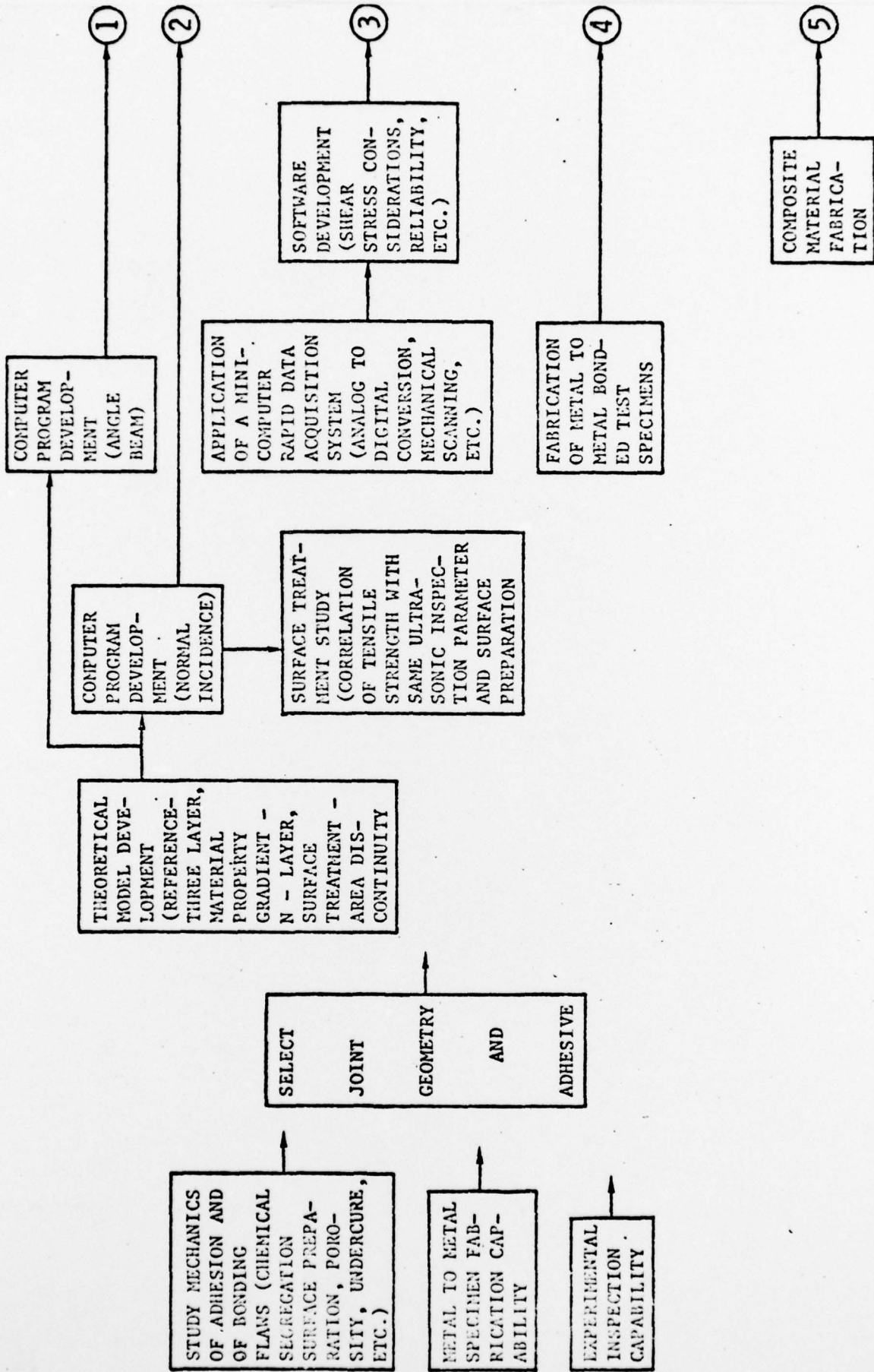

TABLE I - PROGRAM OF STUDY - ULTRASONIC PROCEDURES FOR THE DETERMINATION OF BOND STRENGTH (PAGE 1 OF 2)

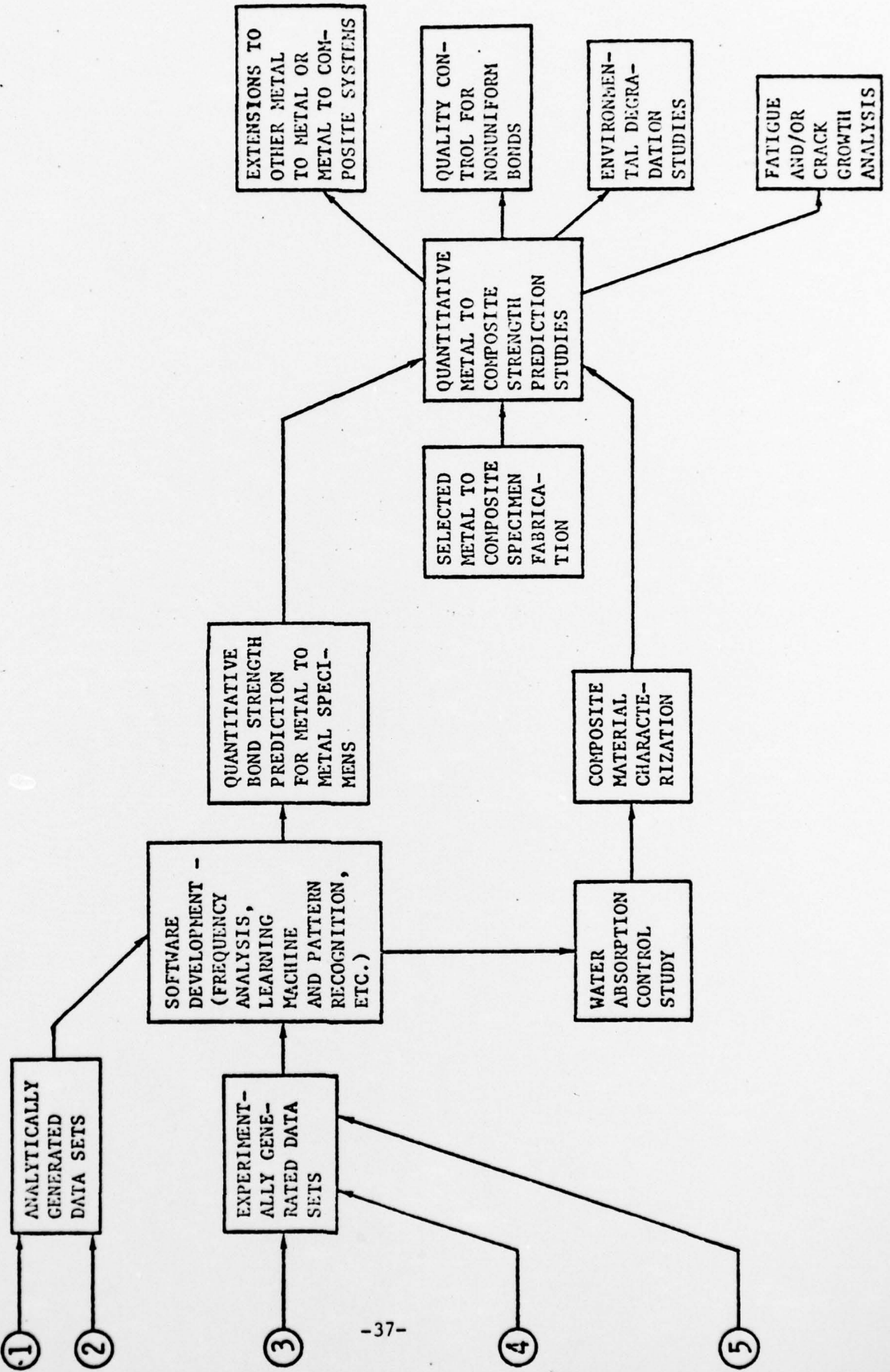

TABLE I - PROGRAM OF STUDY - ULTRASONIC PROCEDURES FOR THE DETERMINATION OF BOND STRENGTH (PAGE 2 OF 2)

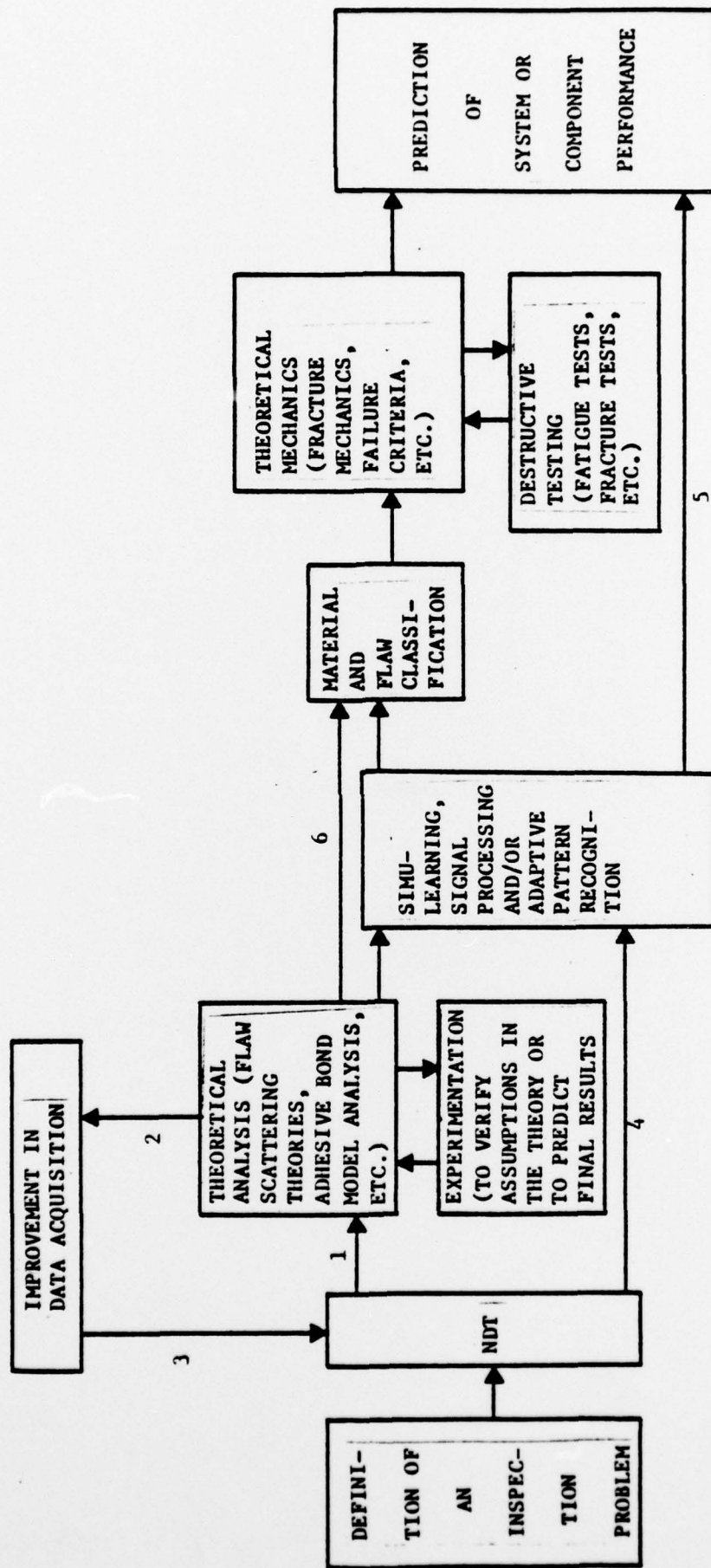

TABLE II - NDT VALUES IN THE MATERIAL AND FLAW CLASSIFICATION SYSTEM PERFORMANCE POTENTIAL PREDICTION PROBLEM

TABLE III - A PROPOSED SIMULEARNING COMPUTATION PROCEDURE

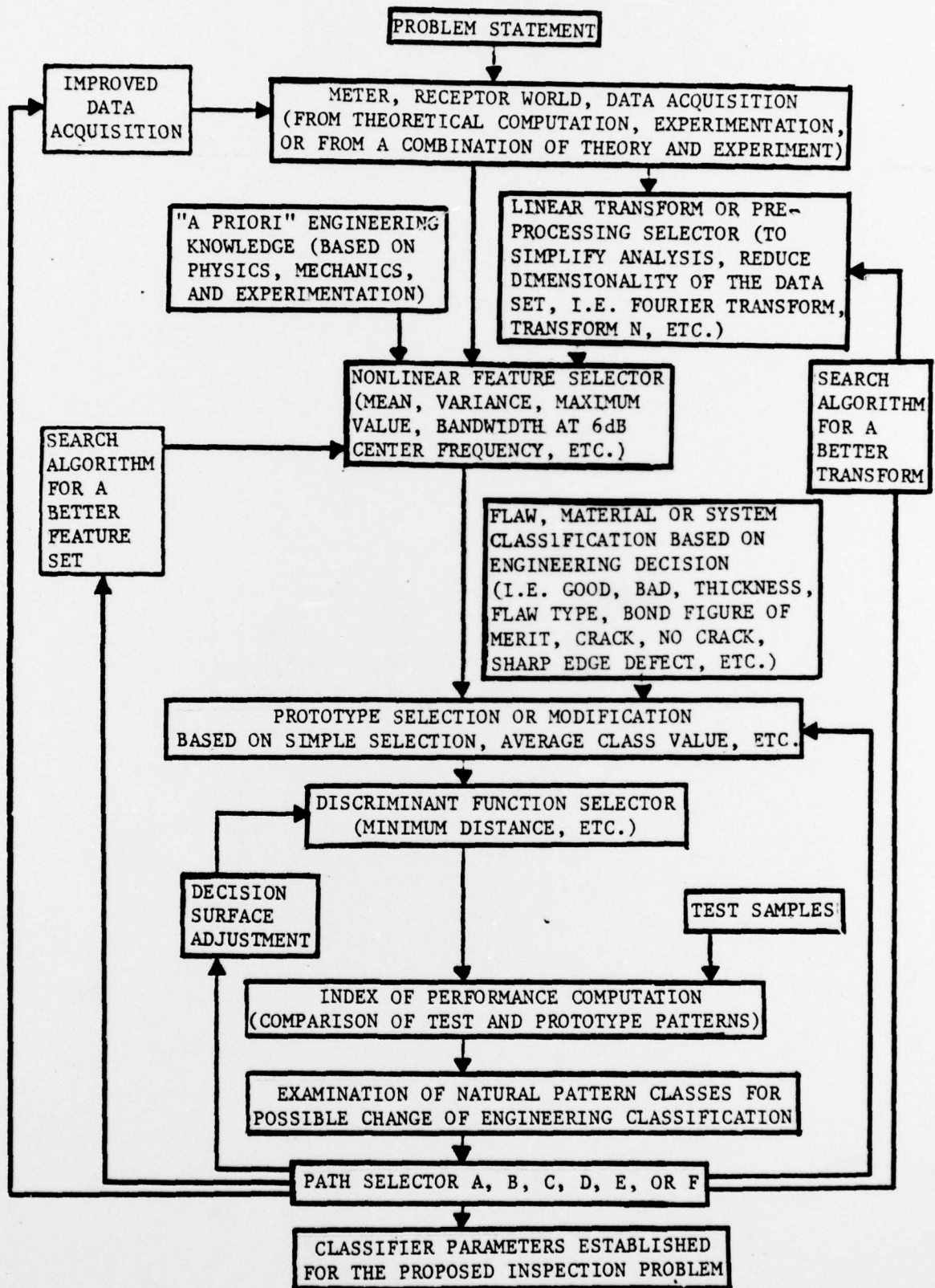

TABLE IV -
 CHARACTERISTICS OF THE TWELVE ADHESIVE BOND SPECIMENS
 FOR SERIES I, II, AND III

Specimen No.		Surface Preparation		Bond Quality Classification
Batch 1	Batch 2	Top	Bottom	
1	7	Yes	Yes	1
2	8	Yes	Yes	1
3	9	Yes	No	2
4	10	Yes	No	2
5	11	No	No	3
6	12	No	No	3

TABLE V - SERIES IV SPECIMEN PERFORMANCE DATA

<u>Specimen No.</u>	<u>Failure Load (lbs.)</u>
37	4330
38	3600
39	2080
40	2460
41	4280
42	4030
43	2290
44	2750
45	0*
46	480
47	300
48	0*
49	4310
50	3100
51	2760
52	2670
53	2300
54	1850
55	2900
56	3300
57	3100
58	2850
59	2640
60	3070

*Specimen failed while being mounted in testing machine.

Appendix 1 - Sample Probability Density Function Curves

A sample PDF curve for Feature 8, as distributed over the two bond classes is shown in Figure A1. This particular example shows some promise of separating class 1 from class 2 when considering the threshold value 1.7. Although this feature does not separate the two classes with 100% reliability, a combination of this result for Feature 8 with the probabilistic results of the other 12 features considered in this study, would hopefully provide us with class separation, with a suitable algorithm in pattern recognition.

The probability density function curves are considered in the program of study for the following principle reasons:

1. To examine feature potential for class separation.
2. To incorporate a series of threshold values useful in a fuzzy logic sequence for a reasonably high separation index of performance.
3. The prototype selection associated with either maximum probable value or mean value for use in establishing algorithms in pattern classification.

FE
 ALL-1E FE-1 IN THE NUMBER OF POINTS
 NO
 EXP. THE FEAT. FIL. NAME
 (0.1E-01)

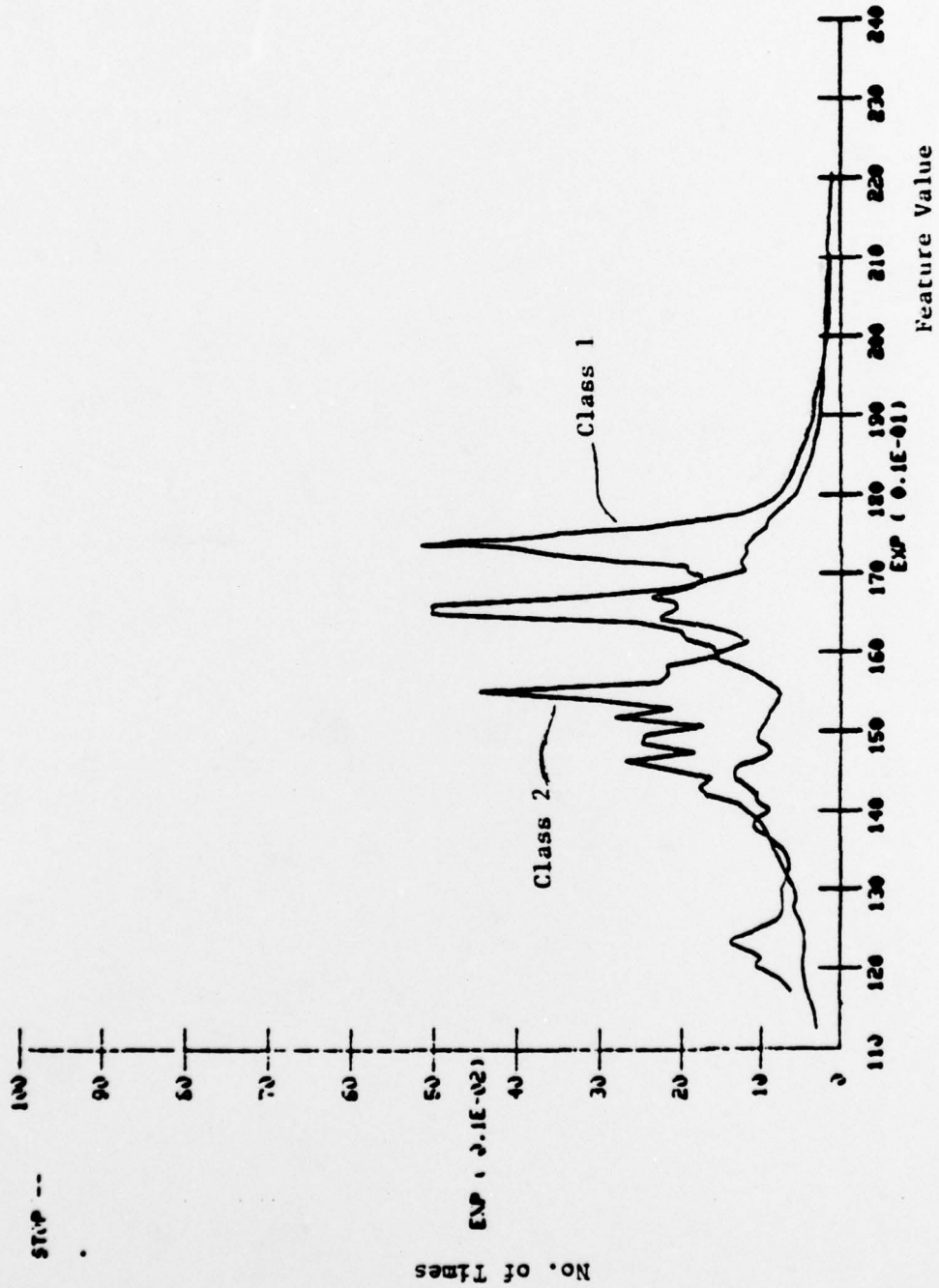

FIG. A1 - SAMPLE PDF CURVES FOR FEATURE 8 FOR THE TWO-CLASS BOND INSPECTION PROBLEM IN SERIES III.

Appendix 2 - Sample Test Data

Each series of bond specimens is subjected to ultrasonic examination in an immersion tank before loading to failure in an Instron testing machine. Failure loads are recorded for each specimen and provide the basis for forming the class structure into which each specimen is to be categorized.

All ultrasonic data is taken in the pulse echo mode using a 1/4 inch diameter, 10 MHz highly damped straight beam transducer placed 1.5 inches above the top surface of the bond specimen. Each bond area is scanned several times in an effort to minimize error due to noise in the system. Data is taken at six points from each bond to account for the possibility of non-uniform specimens. Spatial averaging may be applied to the six amplitude-time curves or to the six resulting feature vectors obtained from each scan. A sample amplitude-time signal along with its amplitude-frequency profile and associated feature vector elements is shown on the next two pages. Sample feature values are also listed on the next two pages.

```

INPUT FILE ----- 7971
DATA SET NO. ----- 8
SUM SQ. ERROR ----- 0.1014E+02
PEAK-TO-PEAK REF. ----- 0.1750E+01
PEAK-TO-PEAK ----- 0.7441E+00
ACTIVITY REGION ----- 0.4584E+00
ERAT ----- 0.2510E-01
LAY ----- 0.1400E+01
A3 / A1 ----- 0.3260E+01
A3 / A5 ----- 0.1470E+01
A1 / A2 ----- 0.2887E+01
AS / A4 ----- 0.1763E+01
A2 FREQUENCY ----- 0.4617E+01
A4 FREQUENCY ----- 0.9811E+01
NO. OF REL. MAX & MIN ----- 1
BANDWIDTH OF SIGNAL ----- 0.4040E+01
MID-FREQUENCY ----- 0.7406E+01

```

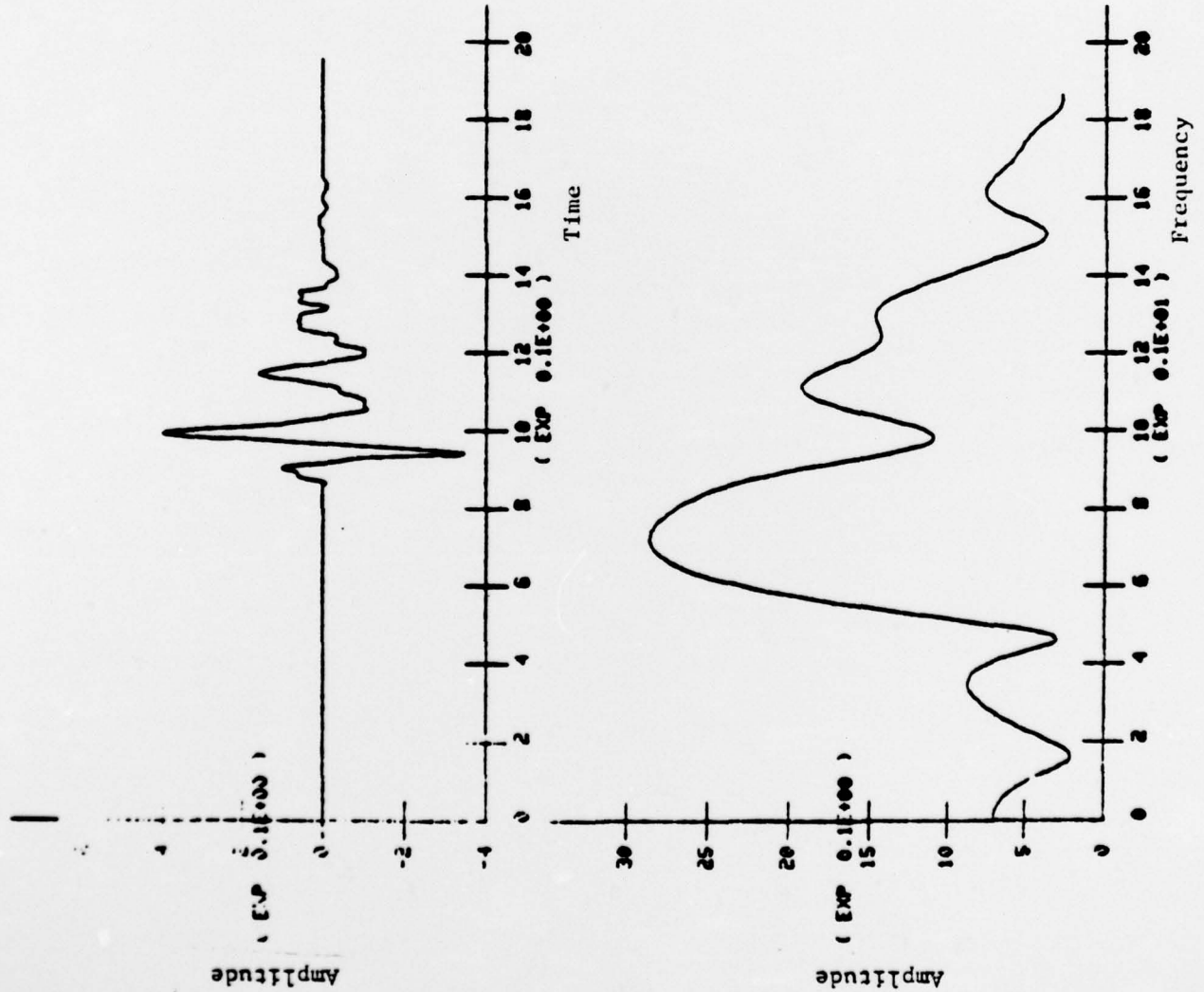

FIG. A2a - SAMPLE TEST DATA FOR SPECIMEN NO. 79 - GOOD