

AD-A038 307

ROME AIR DEVELOPMENT CENTER GRIFFISS AFB N Y  
USE OF MODEM REGENERATION OF THE AUTOVON.(U)  
FEB 77 J B EVANOWSKY  
RADC-TR-77-3

F/G 17/2

UNCLASSIFIED

NL

| OF |  
AD  
A038 307  
FEB 77



END  
DATE  
FILMED  
5-77

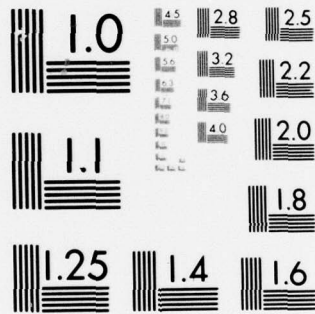

MICROCOPY RESOLUTION TEST CHART  
NATIONAL BUREAU OF STANDARDS-1963-A

AD A 038307

12

6

RADC-TR-77-3  
In-House Report  
February 1977



USE OF MODEM REGENERATION ON THE AUTOVON

John B. Evanowsky

Approved for public release; distribution unlimited.

DDC  
RECEIVED  
APR 15 1977  
A

ROME AIR DEVELOPMENT CENTER  
AIR FORCE SYSTEMS COMMAND  
GRIFFISS AIR FORCE BASE, NEW YORK 13441

DC FILE COPY

This report has been reviewed by the RADC Information Office (OI) and is releasable to the National Technical Information Service (NTIS). At NTIS it will be available to the general public, including foreign nations.

This report has been reviewed and is approved for publication.

APPROVED:

*John D. Kelly*  
JOHN D. KELLY  
Chief, Telecommunications Branch  
Communications & Control Division

APPROVED:

*Fred I. Diamond*  
FRED I. DIAMOND, Technical Director  
Communications and Control Division

FOR THE COMMANDER:

*John P. Huss*  
JOHN P. HUSS  
Acting Chief, Plans Office

Do not return this copy. Retain or destroy.



**UNCLASSIFIED**

SECURITY CLASSIFICATION OF THIS PAGE(When Data Entered)

constituent links of a channel using regeneration.

2

**UNCLASSIFIED**

SECURITY CLASSIFICATION OF THIS PAGE(When Data Entered)

PREFACE

Tests and analysis described in this report were accomplished under Job Order Number 93870104.

The author wishes to extend his appreciation to Norman J. Sturdevant and Captain Jeffrey D. Ives for their valuable assistance during this program.

ACCESSION FOR	
RTG	Write Section <input checked="" type="checkbox"/>
EGG	Buff Section <input type="checkbox"/>
UNANNOUNCED	<input type="checkbox"/>
JUSTIFICATION	
BY	
DISTRIBUTION/AVAILABILITY CODES	
FILE	ACAM. SER. N. SERIAL
A	

## TABLE OF CONTENTS

	<u>Page No.</u>
Introduction	1
Description of Problem	1
Test Configurations	4
Test Results	8
Conclusions and Recommendations	12

## LIST OF FIGURES

<u>Figure No.</u>		<u>Page No.</u>
1	Basic Regeneration	2
2	9303 Test Configuration	6
3	Distribution of Bit Error Rates for Regeneration vs Analog Loopback Comparison	11

#### INTRODUCTION:

The motivation for this effort arose from a question posed by the Joint Steering Committee of the Communications Standard Program. The question was - Can a set of rules be established relative to how often a modem signal should be reconstructed or regenerated in a large network to provide a particular or a best level of user-to-user bit error rate performance? RADC's Digital Communications Experimental Facility (DICEF) agreed to use its resources to answer this question as it applies to commercial modems operating over the switched AUTOVON system.

Two basic areas were addressed in this effort, each of which required a different test configuration to analyze. The first objective was to determine the data rates at which regeneration was effective on the switched AUTOVON. The second was to estimate the performance improvement which could be attained with regeneration. The results of these tests were then analyzed using a variety of statistical programs and recommendations provided.

#### DESCRIPTION OF PROBLEM:

A block diagram is shown in Figure 1 which will help define the regenerator configuration used in this study. The conventional manner of transmitting data from the data source on the left to the data sink on the right would be to use a single modulator, transmit the analog signal through the channel, and demodulate at the receive site. For the purpose of this analysis, another modem (modulator-demodulator) was placed between two segments of the AUTOVON. It will prove convenient to identify three error sources at this time. As shown in the figure,  $E_1$  and  $E_2$  are the error rates associated with each of the two segments of the composite.  $E_T$  is the total error rate or the

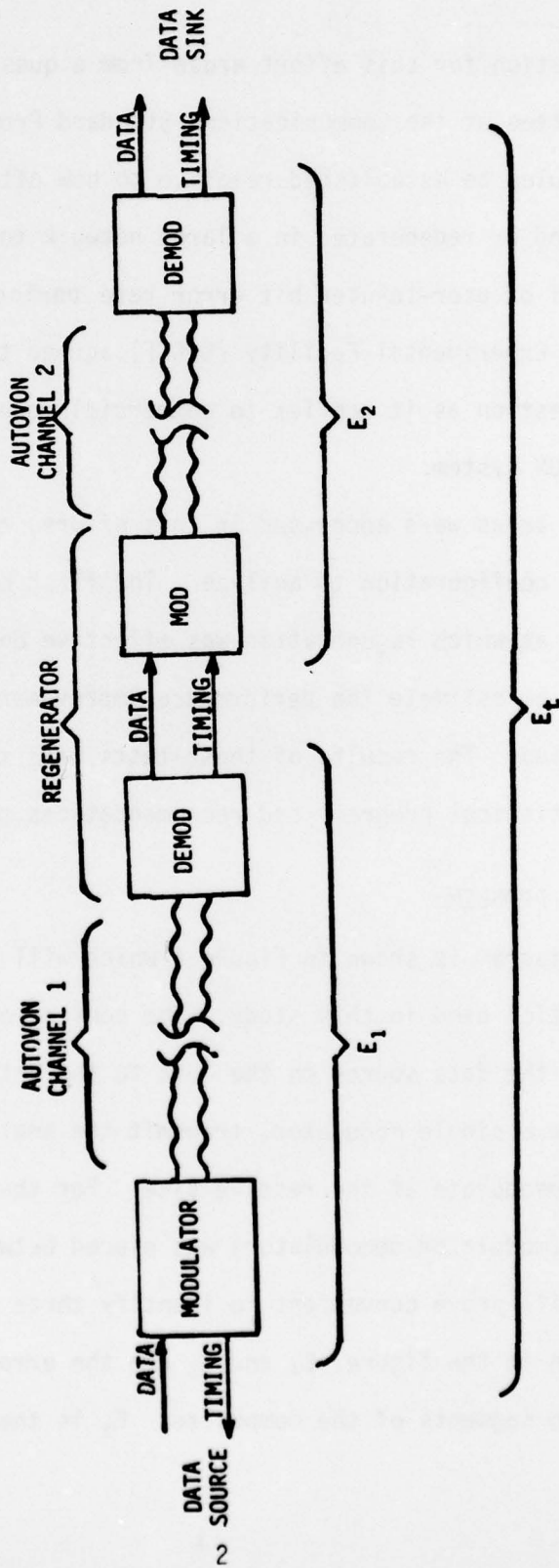

Figure 1  
BASIC REGENERATION

error rate detected by comparing the data at the sink with that which was produced at the source.\* The basic question arises as to how  $E_T$  compares with the error rate which would otherwise result should the regeneration be replaced by a straight through connection.

An examination of the relationship between  $E_T$ ,  $E_1$  and  $E_2$  will reveal some of the idiosyncrasies of regeneration over the switched AUTOVON. First of all,  $E_T$  is bounded as follows:

$$|E_1 - E_2| \leq E_T \leq E_1 + E_2$$

The lower bound depicts the situation in which a bit reversal (error) occurring on the first channel coincides with a reversal on the second channel. For the upper bound a bit reversal on the first channel never coincides with one on the second. The relative distance between  $E_T$  and either bound is affected by the dependence, or conditional probability, of errors on channel one with those on channel two. However, despite the fact that some parameters of channel one and two may be dependent, especially near the regenerative repeater, the propagation delay through the repeater is large enough to essentially remove the time coincidence required by the lower bound. This is due to the fact that sophisticated modem techniques temporarily store a large amount of data for functions such as adaptive equalizers and modulo two scramblers. Only under extreme conditions do channel parameters exist which will move  $E_T$  away from the upper bound. This interaction of  $E_1$  and  $E_2$  will be investigated further in the Test Results Section.

\*The reason for the notation  $E_1$ ,  $E_2$ ,  $E_T$  was to identify error sources. For simplicity, these characters will be used for both bit error rates or corresponding bit errors. Their usage will be obvious in context.

The AUTOVON channels alone produce a unique set of problems. The routing between any two points after each dial through is a random process, such that the channel obtained can have different sets of characteristics. Consequently, all results must be verified for statistical accuracy. Because of the time consuming nature of this process, use of DICEF's wireline simulator was first considered for this effort. However, it was considered critical to preserve any possible correlation between the analog parameters on channels one and two. Since this is not possible using the simulator, it was not utilized for this effort.

#### TEST CONFIGURATIONS:

At the outset, several comments of a general nature are appropriate. The modem chosen for this analysis has an excellent performance record at both 9.6 and 4.8 kilobits per second. As the test program developed, the results proved to be more dependent on channel statistics rather than modem characteristics. The testing was therefore limited to this single modem type so that emphasis could be placed on other test parameters.

To utilize the power of the ITT 9303 processor for the analysis, the data source, regeneration node, and data sink were all collocated in the DICEF. Although this configuration is not representative of a field environment, it is ideal for this analysis because it represents the worst case situation. Indeed, the major complication in this effort was the possible correlation between the two channels. This possibility is maximized with the aforementioned collocation. Even under these extreme conditions it will be shown that this factor does not significantly influence the results.

Due to the statistical nature of these tests, emphasis was placed on randomization to assure valid results. All possible combinations of modem serial numbers and configurations, number of AUTOVON trunks, and times of day were equally weighted to assure that they would not bias the control parameters.

Specifically, the two basic test configurations used consisted of operation with the ITT 9303 processor and operation with a hardware pseudo-random sequence comparator. The 9303 processor has the capability for recording the exact position of every error that occurs for multiple digital channels. The features of this machine will not be enumerated here since literature on this subject is available at the DICEF.\* The 9303 configuration used for this study is depicted in Figure 2. The processor detected errors in the data on channels A and B based on the 33,264 bit PN sequence from its output port. It is noted that this corresponds to the  $E_1$  and  $E_T$  bit error rates, respectively, of Figure 1. These errors were recorded on magnetic tape for subsequent computation of  $E_2$  and statistical post processing.

The first step in the computation of  $E_2$  was the proper alignment of the  $E_1$  and  $E_T$  error patterns to assure examination of corresponding data bits.  $E_2$  was then generated by performing the following comparison:

<u><math>E_1</math></u>	<u><math>E_T</math></u>	<u><math>E_2</math></u>
no error	no error	no error
no error	error	error
error	no error	error
error	error	no error

\*DICEF-RADC's Digital Communications Experimental Facility, SIGNAL (Journal of the Armed Forces Communications And Electronics Association) by James McEvoy and Norman J. Sturdevant.

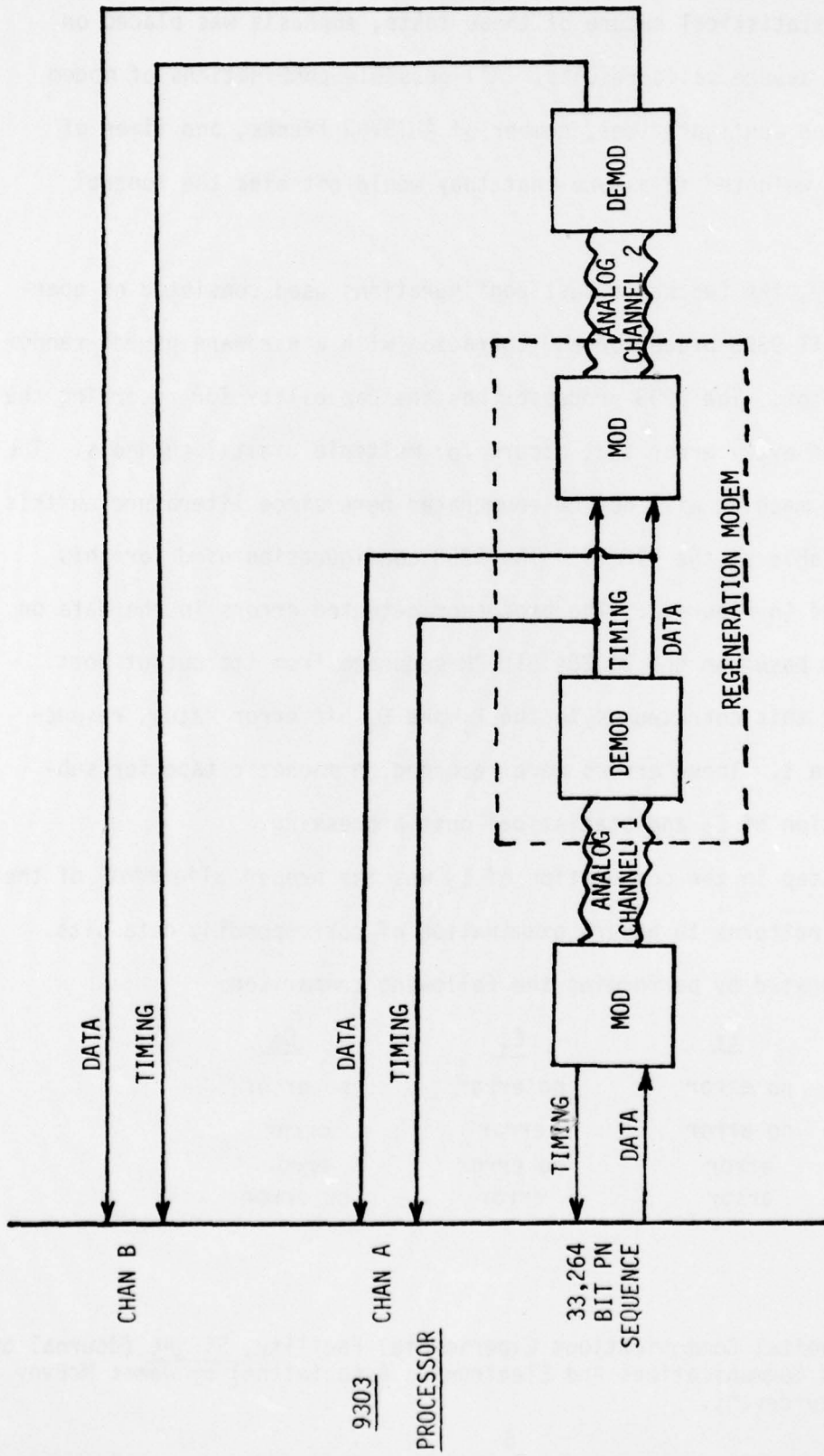

Figure 2  
9303 TEST CONFIGURATION

The basic algorithm in this comparison was the fact that  $E_T$  is the modulo 2 addition or exclusive-or of  $E_1$  and  $E_2$ . In conclusion, it can be seen that the 9303 configuration provides an excellent data source for the examination of correlation between errors on channel one and two of Figure 1.

Many tests were performed which did not require the power of the 9303 processor. These tests were concerned with simply determining the composite bit errors ( $E_T$ ) with the data output of the regenerator's demodulator connected directly to the modulator for retransmission over the second channel. For these tests a modified commercial PN sequence generator and comparator were used to compute bit errors and the results were logged along with experimental parameters. The operation of these PN sequence test sets is so common that reader familiarity is assumed.

In many instances, a comparison was required between operation of a data link (Figure 1) with and without regeneration at the intermediate node. However correct power levels could not be obtained by simply connecting the output of AUTOVON channel one to the input of channel two. To assure a valid comparison, the analog loopback mode of the regeneration modem was used. In this mode the receive telephone line is connected through the receiver AGC to the transmit output amplifier. Using this method all balancing, impedances, and levels were carefully controlled.

Finally, besides the post-processing of error positions recorded on magnetic tape, statistical processing was performed on most of the data to determine statistical validity. For each of the confidence interval computations presented in the Test Results Section, a double sided student's t-distribution was used based on the computed sample variance of the appropriate data. In

each case the computation was based on a 95% confidence level. Details could be obtained from any basic statistics text such as Design and Analysis of Industrial Experiments by Owen L. Davies.

#### TEST RESULTS:

Over 30 test runs were performed using the 9303 processor and the test configuration shown in Figure 2. The average run length for these tests was over an hour and the data rates used were both 9.6 and 4.8 KB/S. Twenty-nine of these runs were successfully compiled and used in this analysis. One characteristic examined was the relationship between  $E_1$ ,  $E_2$ , and  $E_T$ . The general conclusion was the  $E_T$  essentially equals the sum of  $E_1$  and  $E_2$ . This is based on observations from several points of view.

First, a statistical examination was made of the following ratio:

$$\frac{E_1 + E_2}{E_T}$$

where all values are the associated bit error rates for a particular test run. When 29 samples of these ratios were averaged, the resulting sample mean was 1.010 with a sample deviation of 0.0289. The corresponding 95% confidence interval is 0.999 to 1.02. Thus, the conclusion that  $E_T$  essentially equals  $E_1 + E_2$ .

There were several other interesting observations made. It was noted that out of a total 34,348 errors logged by the 9303 processor for this portion of the analysis, 362 errors were cancelled due to a coincidence of an  $E_1$  and  $E_2$  error. This represents about a 1% cancellation rate which is certainly not statistically significant.

It is also noteworthy that cancellation did not seem to be dependent on data rate but on error rate. Out of 29 test runs only 4 runs produced more than one cancellation. Each of these four runs exhibited two characteristics, a high bit error rate and a large number of errors per burst. These four runs were four of the worst five bit error rates recorded (on the order of  $10^{-4}$ ). The fifth of these  $10^{-4}$  error rates did not satisfy the other important factor -- a large number of errors per error burst. A necessary consequence of this correlation between the cancellation rate and high bit error rate (and large number errors per burst), is the continued maintenance of a low cancellation rate since the number of errors is so high for these runs. In fact, even during these four runs the cancellation rate was never greater than 4.5%.

Because cancellation occurred only when the error rate was high, the possibility that the probability of a cancellation could be predicted simply by treating the  $E_1$  and  $E_2$  error rates as independent Poisson processes was investigated. That is, if we assume independence, the probability of an error mechanism from channel one and channel two affecting any one data bit is:

$$\text{Prob (cancellation)} = \text{Prob} (e_1) \text{Prob} (e_2)$$

However if we take one of the questionable four runs as a typical example we find:

$$\frac{\text{number of cancellations}}{\text{total bits transmitted}} \neq (\text{bit error rate 1})(\text{bit error rate 2})$$

$$\frac{133}{13,146,840} \neq 3.38 \times 10^{-4} \quad (3.61 \times 10^{-4})$$

$$1.01 \times 10^{-5} \neq 1.22 \times 10^{-7}$$

The discrepancy of about two orders of magnitude indicates some dependence between errors on channel one and two when the error rate is large enough and/or the errors occur in bursts. Error dependency on AUTOVON as well as other channels is an extensive continuing study at DICEF and any superficial treatment here would not affect the conclusions and may in fact be misleading.

Thus, the conclusion of this investigation is that the composite bit error rate on a channel with regeneration can be assumed to be the sum of the bit error rates that would be measured on each of the composite links. Further, this result held for either 4.8 or 9.6 KB/S.

The next area of investigation was a comparison between digital transmission with and without regeneration. The regenerator configuration was set up as shown in Figure 1 with the data source and sink a commercial PN sequence generator and comparator, respectively. Once a bit error rate computation was made in this mode, the regenerator modem was switched to analog loopback as described in the test configuration section of this report. This effectively removed regeneration and provided a measure of the performance of a single modem operating over channel one and two in tandem. A comparison was then made of the bit error rate obtained in each case.

Before a quantitative analysis is made on the results, attention is drawn to Figure 3 which gives a bar graph representation of the results of 135 test runs. It is noted that the abscissa is on a logarithmic scale and a darkened square indicates an occurrence of one data point in the range of bit error rates indicated. The presentation is made so that the reader can gain an appreciation for the distribution of bit error rates which were

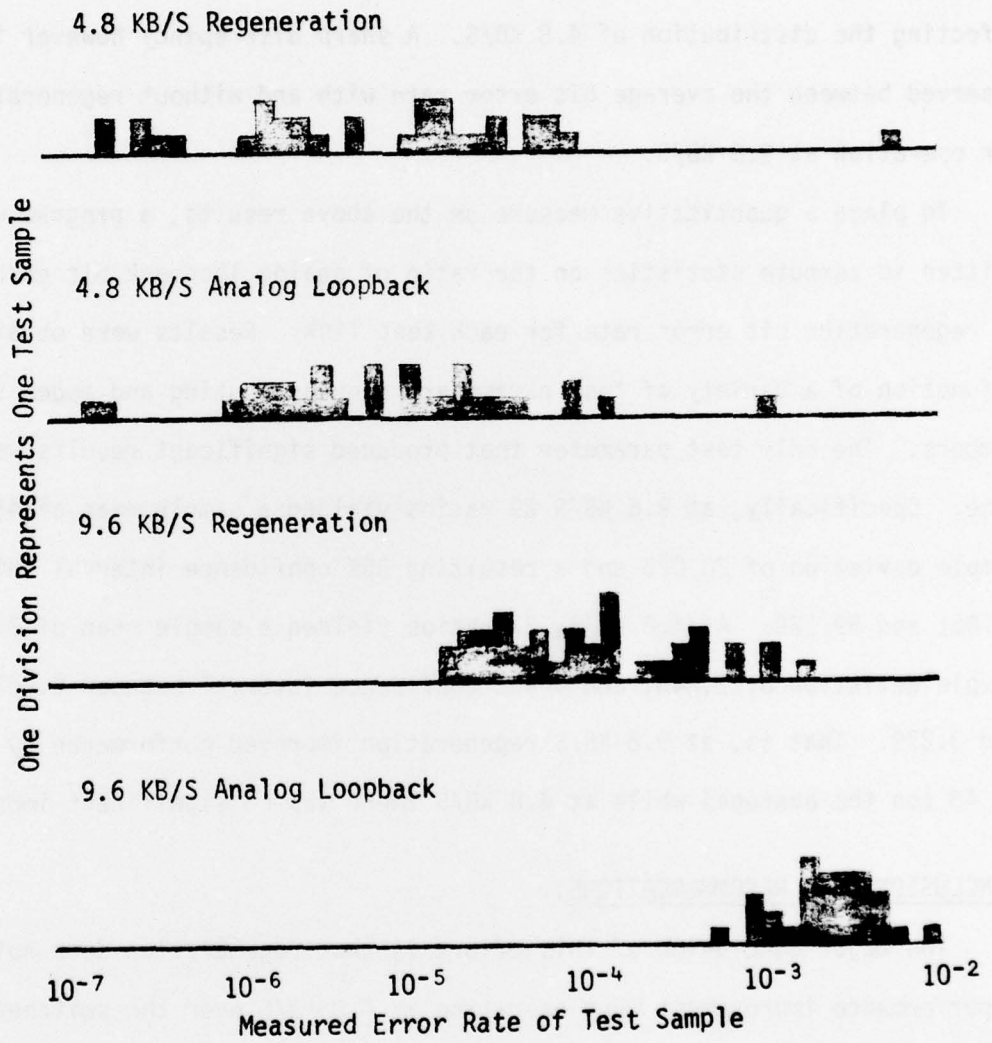

Figure 3  
 DISTRIBUTION OF BIT ERROR RATES FOR  
 REGENERATION vs ANALOG LOOPBACK COMPARISON

obtained at 4.8 and 9.6 KB/S over the AUTOVON.\* Although there is not a one to one correspondence of data points in each of the two modes with this type of presentation, it can also be seen that regeneration is not profoundly affecting the distribution of 4.8 KB/S. A sharp discrepancy however is observed between the average bit error rate with and without regeneration for operation at 9.6 KB/S.

To place a quantitative measure on the above results, a program was written to compute statistics on the ratio of analog loopback bit error rate to regeneration bit error rate for each test link. Results were obtained as a function of a variety of test parameters such as routing and modem serial numbers. The only test parameter that produced significant results was data rate. Specifically, at 9.6 KB/S 29 ratios yielded a sample mean of 48.090, sample deviation of 28.025 and a resulting 95% confidence interval between 37.051 and 59.129. At 4.8 KB/S, 27 ratios yielded a sample mean of 2.123, sample deviation of 2.843, and a 95% confidence interval between 0.967 and 3.279. That is, at 9.6 KB/S regeneration improved performance by a factor of 48 (on the average) while at 4.8 KB/S there was no significant improvement.

#### CONCLUSIONS AND RECOMMENDATIONS:

The major conclusion of this effort is that regeneration does not provide a performance improvement when operating at 4.8 KB/S over the switched CONUS AUTOVON. This is based on the experimental evidence presented in the report and in turn leads to the following rationale. The state-of-the-art in wire-line modulation techniques at 4.8 KB/S is such that these devices are not

\*It is noted that the subject test configuration, on the average, is twice the length of a typical connection for CONUS and as a result the bit error rates are about an order of magnitude higher than a one-way connection.

operating in tight decision regions. That is, there is a large performance margin for relatively steady state channel perturbations such as amplitude and delay vs frequency, harmonic distortion, phase jitter, frequency offset, and additive Gaussian noise because even with the addition of a tandem channel modem operation is not significantly affected. It is probable that channel parameters of a transient nature such as phase hits, amplitude hits, and impulse noise are predominant. Parameters of this type saturate even a conservatively designed modulation system whether or not the signal was regenerated at an intermediate node.

The results of this effort have shown that regeneration may be helpful at 9.6 KB/S. At present, operation at 9.6 KB/S over the switched AUTOVON does not enjoy the wide performance margin mentioned above for 4.8 KB/S. On the contrary, operation at 9.6 KB/S is minimally acceptable and the addition of any channel perturbations (whether steady state or not) can quickly render the channel useless for data communication. The results for a typical AUTOVON circuit may not be as dramatic as those shown on page 12 for the unusually long circuits tested but regeneration may be practical in special cases. The system designer should be cautioned, however, against indiscriminate use of regeneration at higher data rates. There must be assurance that the process of reducing the signal to baseband from carrier and up again even with regeneration did not do more harm than good.

Finally, it has been determined that the total bit error rate for a channel with regeneration is simply the sum of the bit error rates of the two constituent channels. That is, the modulation techniques essentially remove all error coincidences between the two paths even when the underlying channel

perturbations may be dependent. This conclusion may be of interest to a system designer requiring an estimate of performance improvement with regeneration at 4.8 and 9.6 KB/S on the switched AUTOVON, given bit error rate performance between nodes.

## METRIC SYSTEM

### BASE UNITS:

Quantity	Unit	SI Symbol	Formula
length	metre	m	...
mass	kilogram	kg	...
time	second	s	...
electric current	ampere	A	...
thermodynamic temperature	kelvin	K	...
amount of substance	mole	mol	...
luminous intensity	candela	cd	...

### SUPPLEMENTARY UNITS:

plane angle	radian	rad	...
solid angle	steradian	sr	...

### DERIVED UNITS:

Acceleration	metre per second squared	...	m/s
activity (of a radioactive source)	disintegration per second	...	(disintegration)/s
angular acceleration	radian per second squared	...	rad/s
angular velocity	radian per second	...	rad/s
area	square metre	...	m
density	kilogram per cubic metre	...	kg/m
electric capacitance	farad	F	A-s/V
electrical conductance	siemens	S	A/V
electric field strength	volt per metre	...	V/m
electric inductance	henry	H	V-s/A
electric potential difference	volt	V	W/A
electric resistance	ohm	...	V/A
electromotive force	volt	V	W/A
energy	joule	J	N-m
entropy	joule per kelvin	...	J/K
force	newton	N	kg-m/s
frequency	hertz	Hz	(cycle)/s
illuminance	lux	lx	lm/m
luminance	candela per square metre	...	cd/m
luminous flux	lumen	lm	cd-sr
magnetic field strength	ampere per metre	...	A/m
magnetic flux	weber	Wb	V-s
magnetic flux density	tesla	T	Wb/m
magnetomotive force	ampere	A	...
power	watt	W	J/s
pressure	pascal	Pa	N/m
quantity of electricity	coulomb	C	A-s
quantity of heat	joule	J	N-m
radiant intensity	watt per steradian	...	W/sr
specific heat	joule per kilogram-kelvin	...	J/kg-K
stress	pascal	Pa	N/m
thermal conductivity	watt per metre-kelvin	...	W/m-K
velocity	metre per second	...	m/s
viscosity, dynamic	pascal-second	...	Pa-s
viscosity, kinematic	square metre per second	...	m/s
voltage	volt	V	W/A
volume	cubic metre	...	m
wavenumber	reciprocal metre	...	(wave)/m
work	joule	J	N-m

### SI PREFIXES:

Multiplication Factors	Prefix	SI Symbol
1 000 000 000 000 = 10 <sup>12</sup>	tera	T
1 000 000 000 = 10 <sup>9</sup>	giga	G
1 000 000 = 10 <sup>6</sup>	mega	M
1 000 = 10 <sup>3</sup>	kilo	k
100 = 10 <sup>2</sup>	hecto*	h
10 = 10 <sup>1</sup>	deka*	da
0.1 = 10 <sup>-1</sup>	deci*	d
0.01 = 10 <sup>-2</sup>	centi*	c
0.001 = 10 <sup>-3</sup>	milli	m
0.000 001 = 10 <sup>-6</sup>	micro	μ
0.000 000 001 = 10 <sup>-9</sup>	nano	n
0.000 000 000 001 = 10 <sup>-12</sup>	pico	p
0.000 000 000 000 001 = 10 <sup>-15</sup>	femto	f
0.000 000 000 000 000 001 = 10 <sup>-18</sup>	atto	a

\* To be avoided where possible.