

AD-A038 407

ARMY MEDICAL INTELLIGENCE AND INFORMATION AGENCY WAS--ETC F/G 6/5
SURGICAL STAPLING MACHINE FOR CONNECTING FLAT BONES (KHIRURGICH--ETC(U)
DEC 73 S A MAKAROV, Y V EFIMOV, V G SIDORENKO

UNCLASSIFIED

USAMIIA-K-4353

NL

| OF |
AD
A038 407



END

DATE
FILMED
5 - 77

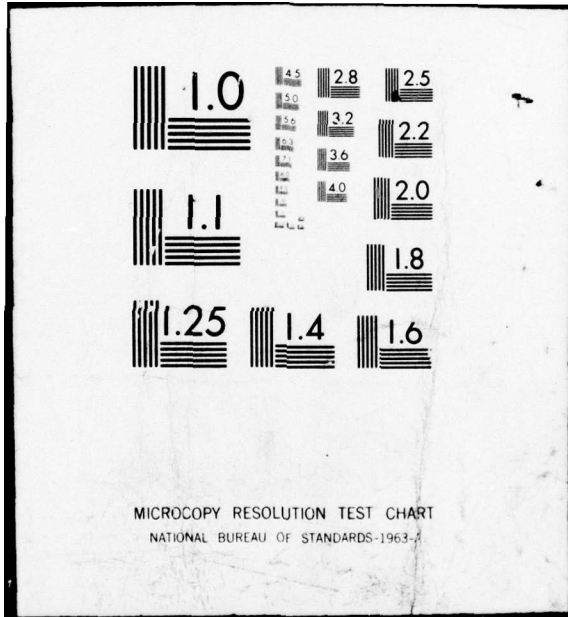



DEPARTMENT OF THE ARMY
U.S. ARMY MEDICAL INTELLIGENCE AND INFORMATION AGENCY
WASHINGTON, D.C. 20314

AD A 038407

Number: (14) USAMIIA-K-4353 ✓

Date Completed: (11) 18 Dec 1973

Language: Russian

Geographic Area:

English Title: (6) SURGICAL STAPLING MACHINE FOR CONNECTING FLAT BONES

Foreign Title: (Khirurgicheskiy Sshivayushchiy Apparat dlya Soyedineniya Ploskikh Kostey)

Author: (10) S. A./Makarov, Yu. V./Efimov and V. G./Sidorenko

Source Document: Soviet Patent No. 342,615

Pages Translated: All (4)

Publisher: "Meditsina" Press

Date/Place Publication: 1972, Leningrad

Distribution Statement: Approved for public release; distribution unlimited

10

12 5p.

DDC
APR 19 1977
C

DDC FILE COPY



409112

ACQUISITION OR		
RTIS	White Section	<input checked="" type="checkbox"/>
DEC	Buff Section	<input type="checkbox"/>
UNANNOUNCED <input type="checkbox"/>		
JUSTIFICATION		
BY		
DISTRIBUTION/AVAILABILITY CODES		
USL	AVAIL. Rtd. or	SPECIAL
A		

The invention pertains to the area of medicine and involves surgical stapling machines for connecting flat bones.

Known surgical devices for this purpose, containing handles with working jaws — a stapler with a groove for the staple and a striker with a device to limit its motion and a support with a matrix for bending the staple — are insufficiently reliable or inconvenient to use.

The purpose of the invention is to develop an apparatus whose nature excludes the possibility of premature and improper bending of the staple and is more reliable in operation.

For this purpose, the handles of the proposed device are joined by a hinge on which there is a bracket with a working head, constituting a housing with a cylinder and cover mounted on it. Inside of this there is a bushing which can be moved with a supporting edge, and a striker with projections located on its end and a spring-loaded lock to hold the staple. The housing, bushing and striker have grooves for the staple; these grooves in the bushing have a helical shape and are diametrically opposite to each other in cross section. In addition, to ensure reliable holding of the staple, the spring-loaded lock is advantageously made in the form of a V-shaped grip.

Figure 1 shows the proposed device in a general view; Figures 2 and 3 show the working jaws of the apparatus in cross section.

The surgical stapling device for connecting flat bones contains spring-loaded handles 1 with double linkage, fitted with operating upper stapling jaw 2 and lower supporting jaw 3. Between the jaws is mounted a bracket 4 on hinges on which the working head 5 is located, made in the form of a cylinder 6 with a cap 7 and a housing 8. On the inside surface of the housing there are two parallel slots 9, at whose level are located pins 10 on the outside. Inside the housing, there is a bushing 11 which has a limiting edge 12 and two slots 13, mounted crosswise on diametrically opposite sides and set at an angle of 11 degrees to the lengthwise axis of head 5. Striker 14, located inside bushing 11, has cutters 15, slot 16 beneath lock 17 with a flat spring 18. The lock is fitted with an edge 19 for locking the back of the clamp and an oval depression 20 for axis 21 which passes through striker 14. On lower

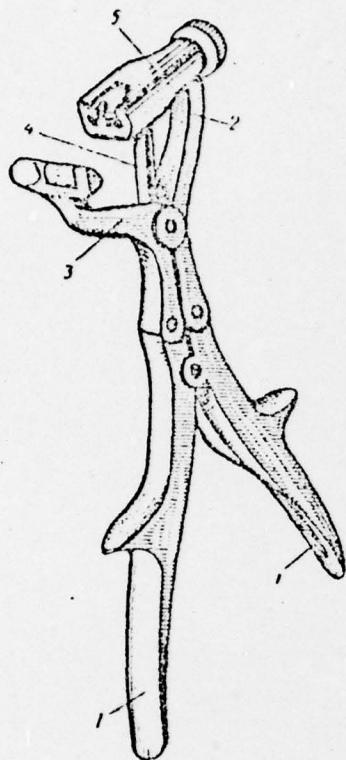

Figure 1.

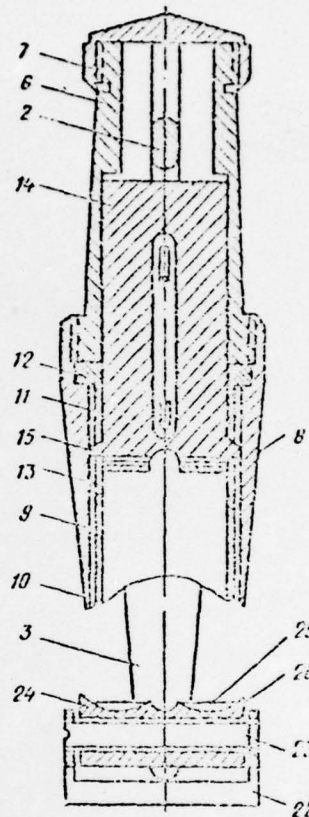

Figure 2.

jaw 3, by means of a threaded joint, is fastened a fork-counter support 22 with a matrix 24 mounted on axis 23, having two spherical depressions 25 and two fastening clamps 26.

Under aseptic conditions, a U-shaped staple is placed by means of forceps in the parallel slots 9 in the housing of the device. As the clip moves forward further, bushing 11 turns due to the motion of blade 15 of the striker along side slots 13. At the same time, edge 19 on clamp 17 comes in contact with striker 14, which holds the back of the staple firmly. Then, for final discharge of the device, the striker moves all the way against the support. After exposure of the fracture site, the bone fragments are repositioned and fastened in the correct position. The loaded device, with the jaws open, is applied to the bone, which is placed between the head 5 and the matrix 24. Due to the mobility of the matrix in two mutually perpendicular planes, the latter can be adjusted to the shape of the bone by shifting the handles slightly. With further movement of the handles, the upper working jaw 2 sets striker of knife 15 in motion which, sliding along the side grooves of bushing

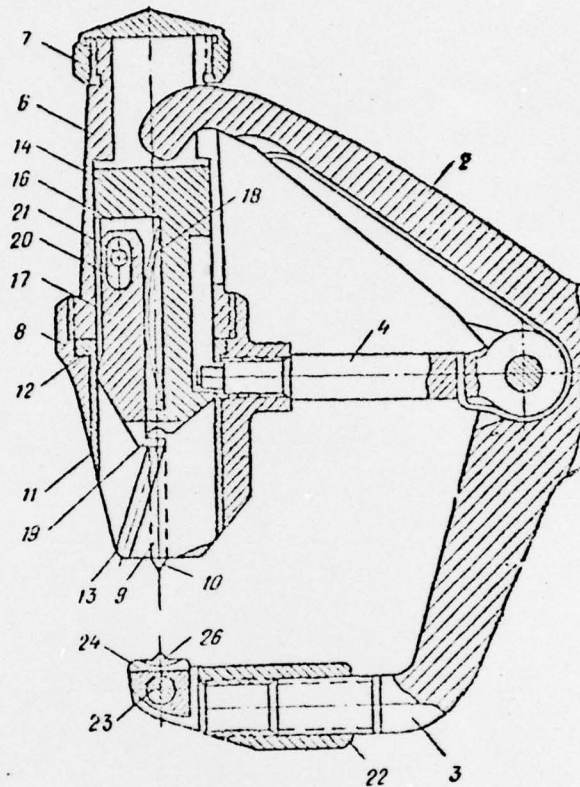

Figure 3.

11, turns it around its axis. The bushing covers the points of the staple, located in parallel grooves in housing 8, keeping them from being distorted. The points of the staple pass through the outer cortical layer of bone and move on into the spongy substance. At this time, the staple clamp is freed from holder 17, due to the action of a flat spring that is mounted in the striker. Then, after passing through the internal cortical layer, the tips of the staple, coming in contact with the spherical depression 25 in matrix 14, are bent and come to rest flat against the bone.

OBJECT OF THE INVENTION

1. Surgical stapling device for joining flat bones, consisting of handles with working jaws: a stapling jaw with a groove for the staple, and a support jaw with a matrix for bending the staple. In order to exclude the possibility of premature and incorrent bending of the staple and to ensure convenience in operation, the handles are hinged on an axis on which is mounted a bracket with a working head. This head represents with a cylinder

mounted on it with a cap, within which is moveably mounted a bushing with a supporting edge and a striker, fitted with projections located on its end. It includes a spring-loaded clamp for holding the staple. In the housing, bushing and striker there are grooves to accept the staple, so that the grooves in the bushing have a helical shape and are located diametrically opposite one another as viewed in cross section.

2. A surgical stapling device according to Claim 1. In order to ensure reliable closure of the staple, the spring-loaded lock is made in the form of a L-shaped lever.