

AD-A038 469

AEROMET INC NORMAN OKLA
HAWADS EQUIPMENT DESCRIPTION AND OPERATIONAL MANUAL.(U)
JAN 77 D R BOOKER, J WINDES
770112

F/G 4/2

F19628-76-C-0103

AFGL-TR-77-0066

NL

UNCLASSIFIED

1 OF 2

AD
A038469

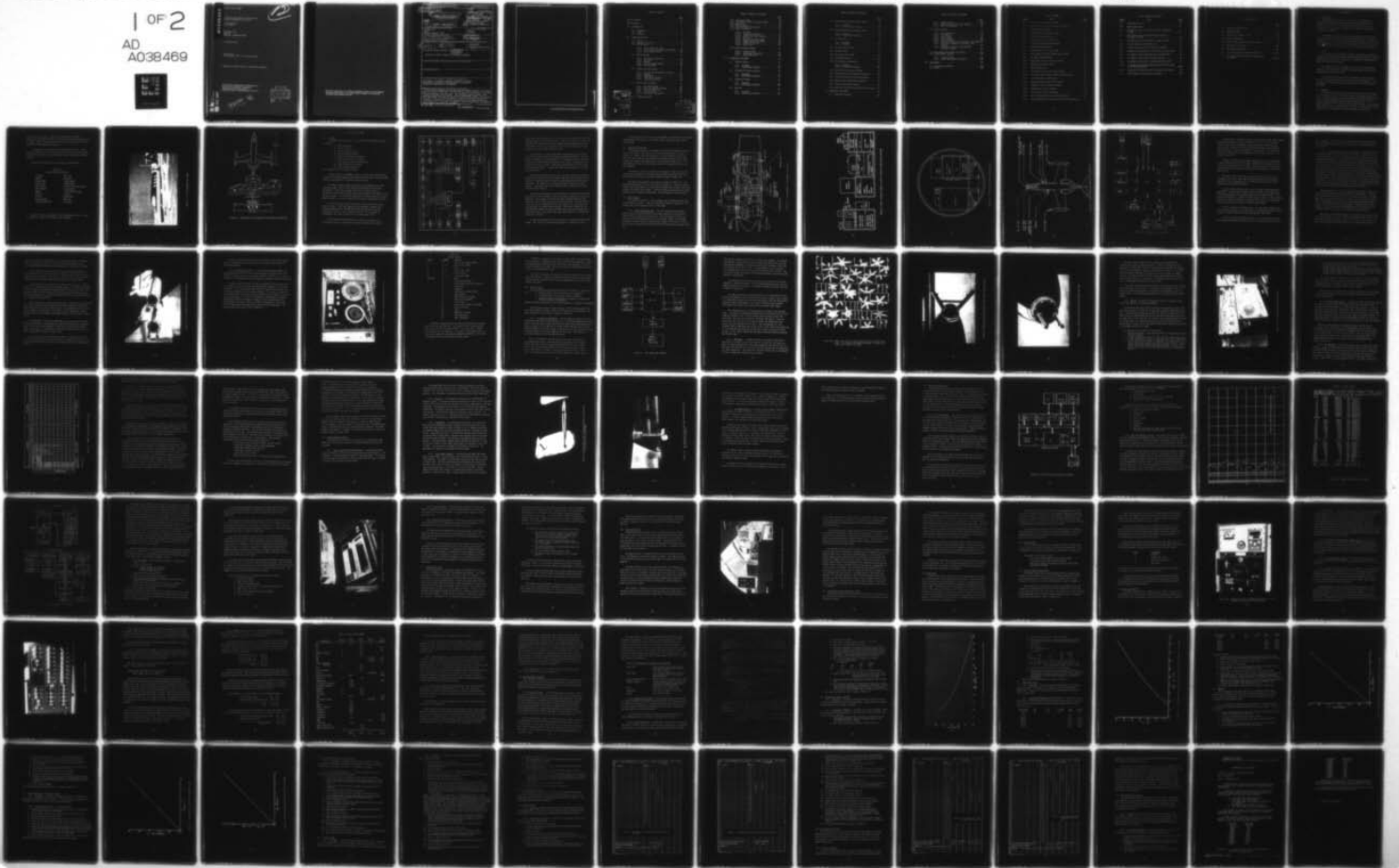

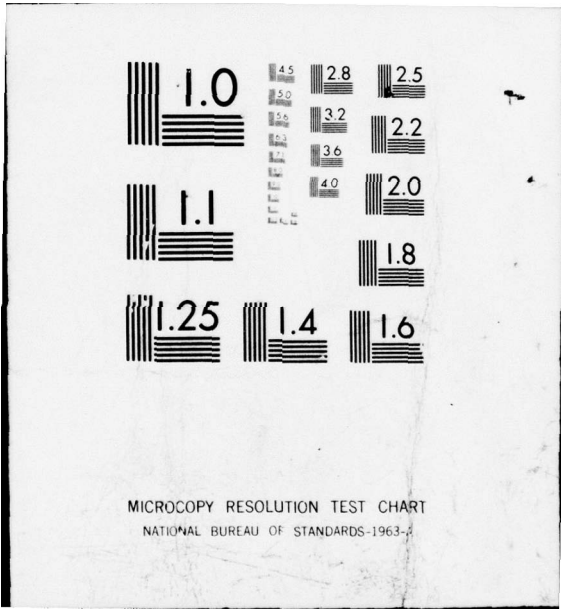

MICROCOPY RESOLUTION TEST CHART
NATIONAL BUREAU OF STANDARDS-1963-A

ADA 038469

AFGL-TR-77-0066

12 ^{FG}

HAWAII EQUIPMENT DESCRIPTION
AND OPERATIONAL MANUAL

D. Ray Booker
Joe Windes

Aeromet, Inc.
Box FF
Norman, Oklahoma 73070

12 January 1977

Final Report
22 September 1975 - 31 December 1976

Approved for public release; distribution unlimited.

AIR FORCE GEOPHYSICS LABORATORY
AIR FORCE SYSTEMS COMMAND
UNITED STATES AIR FORCE
HANSCOM AFB, MASSACHUSETTS 01731

DDC
RECEIVED
APR 20 1977
REGULATED
D
He

AD No. _____
DDC FILE COPY

392168 s/c

Qualified requestors may obtain additional copies from the Defense Documentation Center. All others should apply to the National Technical Information Service.

19 REPORT DOCUMENTATION PAGE		READ INSTRUCTIONS BEFORE COMPLETING FORM	
18 1. REPORT NUMBER AFGL TR-77-0066	2. GOVT ACCESSION NO.	9 3. REPORT'S CATALOG NUMBER	
4. TITLE (and Subtitle) 6 HAWADS EQUIPMENT DESCRIPTION AND OPERATIONAL MANUAL.		5. TYPE OF REPORT & PERIOD COVERED Final Report 22 Sep 75 - 31 Dec 76	
7. AUTHOR(s) 10 D. Ray Booker and Joe Windes		14 6. PERFORMING ORG. REPORT NUMBER 770112	
9. PERFORMING ORGANIZATION NAME AND ADDRESS Aeromet, Inc. Box FF Norman, Oklahoma 73070		15 8. CONTRACT OR GRANT NUMBER(s) F19628-76-C-0103 / NEW	
11. CONTROLLING OFFICE NAME AND ADDRESS Air Force Geophysics Laboratory Hanscom AFB, Massachusetts 01731 Monitor/Donald McLeod/LYC		11 12. REPORT DATE 12 Jan 77	
14. MONITORING AGENCY NAME & ADDRESS (if different from Controlling Office) 12 125p. 16 627A		13. NUMBER OF PAGES 128	
16. DISTRIBUTION STATEMENT (of this Report) 17 00 Approved for public release; distribution unlimited.		15. SECURITY CLASS. (of this report) UNCLASSIFIED	
15a. DECLASSIFICATION/DOWNGRADING SCHEDULE			
17. DISTRIBUTION STATEMENT (of the abstract entered in Block 20, if different from Report)			
18. SUPPLEMENTARY NOTES			
19. KEY WORDS (Continue on reverse side if necessary and identify by block number) Cloud Physics Instruments, Airborne Instruments, Particle Measurements, Instrument System Maintenance, Calibration Procedures, Meteorological Instruments.			
20. ABSTRACT (Continue on reverse side if necessary and identify by block number) A High Altitude Weather Aircraft Data System (HAWADS) installed in a Learjet Model 36 aircraft is described. The aircraft was selected because of its high altitude performance and long range. The instrument system includes flight conditions sensors and five optical particle spectrometer probes. Two are very high speed probes for making 2D images of clouds and precipitation particles. A computer is included for realtime computations of cloud water content and radar reflectivity. Principles of operation, detailed operational, calibration and maintenance procedures are described.			

15

SECURITY CLASSIFICATION OF THIS PAGE(When Data Entered)

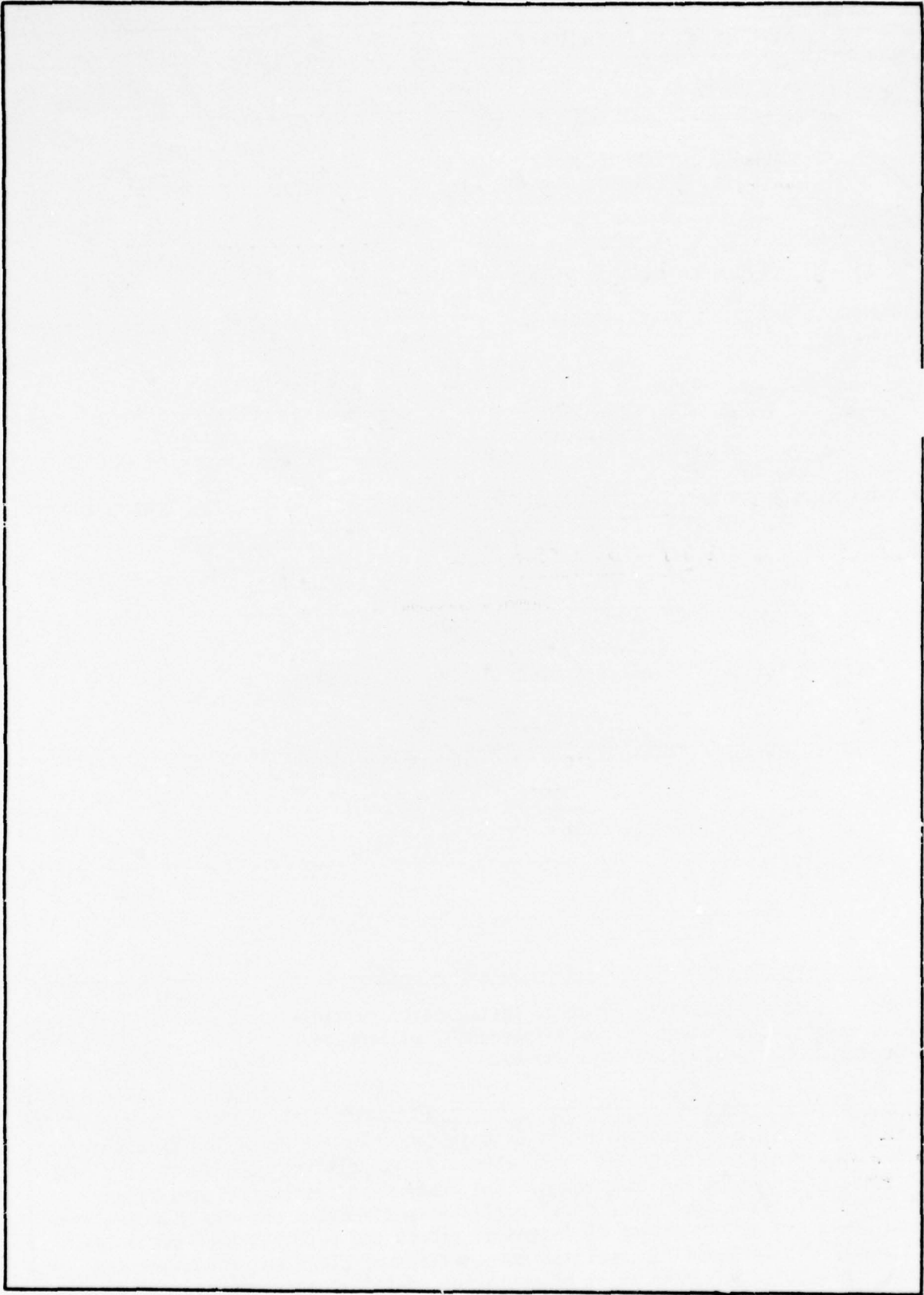

SECURITY CLASSIFICATION OF THIS PAGE(When Data Entered)

TABLE OF CONTENTS (Continued)

	<u>Page</u>
2.8 Time Lapse Camera	49
2.9 Total Water Content Instrument (TWCI)	50
2.10 Snow Stick	51
2.11 AIP/Transmuter	52
2.12 Project Communication System	52
2.13 Power Distribution	53
2.13.1 DC Power	55
2.13.2 Topaz 60 Hz Inverters	55
2.13.3 Low-Voltage Power Supplies	55
2.13.4 Deicing	55
2.13.5 Aircraft Electrical Power	57
2.13.6 HAWADS Power Requirements	58
2.13.7 Protective Devices	60
2.13.8 Cable Lists	61
2.14 Ground Support Equipment	61
2.14.1 Printer Plotter	61
2.14.2 Audio-Tape Transcriber	62
2.14.3 Ground Power Unit	62
3.0 CALIBRATION PROCEDURES	65
3.1 Pressure System	65
3.1.1 Equipment	65
3.1.2 Calibration Procedure	65
3.2 Differential Pressure System	66
3.2.1 Equipment	66
3.2.2 Calibration Procedure	66
3.3 Temperature Sensor	68
3.3.1 Equipment	68
3.3.2 Calibration Procedure	68
3.4 Dewpoint	70
3.4.1 Equipment	70
3.4.2 Calibration Procedure	70

TABLE OF CONTENTS (Continued)

	<u>Page</u>
3.5 Johnson Williams Liquid Water Content	72
3.5.1 Equipment	72
3.5.2 Calibration Procedure	72
3.6 Axial Scattering Spectrometer Probe	75
3.6.1 Equipment	75
3.6.2 Calibration Procedures	75
3.7 1D Cloud Probe	75
3.7.1 Equipment	75
3.7.2 Procedure	76
3.8 1D Precipitation Probe	77
3.9 2D Cloud Probe	77
3.10 2D Precipitation Probe	80
3.11 Time Code Generator	80
3.12 VCO Calibration Procedures	83
3.12.1 Equipment	83
3.12.2 Calibration Procedure	83
3.13 Data Processing System Procedure	86
3.14 Formvar Replicator Calibration Procedure	86
3.15 Time-Lapse Camera Calibration Procedure	86
3.16 AIP/Transmuter Calibration Procedure	86
3.17 Project Communication System	87
3.18 Power Distribution System Calibration Procedure	87
4.0 OPERATIONAL PROCEDURES	88
4.1 Preflight Procedures	88

TABLE OF CONTENTS (Continued)

	<u>Page</u>
4.1.1 Supplies Check	88
4.1.2 Power up and Systems Check Sequence	89
4.1.3 Power down Sequence	92
4.2 Flight Checklist	93
4.2.1 Pre-engine Start	93
4.2.2 Pre-Takeoff	94
4.2.3 After Takeoff	96
4.2.4 After Landing	96
4.2.5 Program Reload	99
4.2.6 Recovery Procedures for the Real Time Program	100
4.2.7 Operating Procedures for the Real Time Program	100
4.2.8 Operating Procedures using the BMS Similator Program	100
4.3 Data Acquisition Channel Assignments	103
4.4 Ground Support Systems	105
4.4.1 Printer Plotter	105
4.4.2 Audio Tape Playback Procedure	107
5.0 MAINTENANCE	109
5.1 Maintenance Procedures	109
5.2 Spares	109

LIST OF FIGURES

<u>Number</u>	<u>Title</u>	<u>Page</u>
1.1	Photo of instrumented Lear N36TA	3
1.2	Three views of Lear with exterior dimensions	4
2.1	Data Flow Block Diagram.	6
2.2	Arrangement of equipment in cabin.	9
2.3	Electronic systems; racks 1-4.	10
2.4	View to aft of cabin; rack no. 5	11
2.5	Externally mounted instrumentation	12
2.6	1D System, Block Diagram	13
2.7	1D probes on nose of the Learjet	17
2.8	Front panel of BMS and Kennedy tape recorder	19
2.9	2D System, Block Diagram	22
2.10	Image slice data for stellar dendrites	24
2.11	PMS 2D precipitation probe	25
2.12	PMS 2D cloud probe	26
2.13	The DAS-2D and the Pertec tape recorder.	28
2.14	Rosemount Total Temperature Sensor and snow stick.	35
2.15	J-W Liquid Water Content Meter	36
2.16	Data Processing System, Block Diagram.	40
2.17	Example of real time plotter output.	42
2.18	Sample output from TI printer.	43
2.19	Flow diagram, real time program.	44
2.20	The TI keyboard, VHF, and audio selector box	47
2.21	Forward-looking time lapse camera and copilot audio box.	51

LIST OF FIGURES (Continued)

<u>Number</u>	<u>Title</u>	<u>Page</u>
2.22	Instrument rack no. 1	56
2.23	Master power panel.	58
3.1	Calibration curve of altitude (pressure) transducer for BMS	67
3.2	Calibration curve of airspeed (delta pressure) transducer for BMS.	69
3.3	Calibration curve of temperature system for BMS	71
3.4	Current dewpoint calibration curve.	73
3.5	Calibration curve for the J-W LWC for the BMS	74
3.6	Example of calibration data from PMS for the 1DC probe. . .	78
3.7	An example of 1DP calibration data from PMS probe	79
3.8	An example of 2DC calibration data from PMS	81
3.9	An example of 2DP probe calibration data from PMS.	82
3.10	A voltage calibration procedure for the DVM to be used in the VCO calibration.	84-85
3.11	Deviation of BMS and DAS from calibrated input signal . . .	87
4.1	Block Diagram, ground support equipment	106

LIST OF TABLES

	<u>Page</u>
1.1 Learjet 36 Specifications	2
2.1 BMS Data Format	20
2.2 Format of the DAS-2D record	30
2.3 Power Loading Chart	59
2.4 Printer/Plotter Interface Specifications	64
4.1 BMS Channel Assignments	103
4.2 DAS Channel Assignments	104
5.1 List of Recommended Vendor Documentation	110-111
5.2 List of Recommended Spare Parts and Supplies for HAWADS	112-114

1.0 INTRODUCTION

1.1 Background

The High Altitude Weather Aircraft Data System (HAWADS) was developed under AFGL/SAMSO sponsorship by Meteorology Research Inc., Altadena, Ca. to describe the hydrometeor environment of missiles. Aeromet, Inc. has been the contractor for operating, maintaining and calibrating the HAWADS.

The HAWADS is a sophisticated data acquisition system for making cloud physics measurements at relatively high altitudes. The data is treated in real time to produce information which can be correlated with radar measurements in order to derive liquid water content measurements. It is used in the decision making process for launching test vehicles.

1.2 Scope

This report describes HAWADS equipment, gives general maintenance information, calibration information and operational procedures. Detailed maintenance and calibration information is available in vendor manuals which are listed in this report.

This report describes the HAWADS as of the time of this writing. Revisions in the equipment, calibration and operational procedure will be published as the system changes.

This report deals with operation, calibration, and maintenance. The use of the data generated by the system is not included here. The aircraft and its systems are not covered except as they interface with the HAWADS.

1.3 Aircraft

The Learjet Model 36 is owned and operated by Thunderbird Airways, Inc. of Houston, Tx. under a subcontract with Meteorology Research, Inc. It is a high performance executive jet capable of sustained operation at speeds in excess of Mach 0.8 and altitudes above 45,000 ft. It is powered by two Garrett Airesearch TFE7312 Turbofan engines, each producing 3500 pounds of thrust. The maximum gross weight is 17,000 pounds, 8,500 pounds of which is available for fuel, passengers, and payload.

With a crew of four and a 2,000 pound instrumentation package, the Lear 36 can climb to 41,000 ft in 18 minutes and then sample for up to six hours. With a reduced payload for ferrying, the Lear 36 can fly up to 2875 nm with standard fuel reserves.

The cabin is 13.8 ft long, 4.8 ft wide and 4.3 ft high. Sensors have been installed in the forward portion of the wing tip tanks weather radar bay of the nose section and through several of the seven fuselage windows.

General specifications for the aircraft are given below.

TABLE 1.1
LEARJET 36 SPECIFICATIONS

Wing Span	39.5 feet
Length	48.7 feet
Gross Weight	17,000 pounds
Useful Load	8,500 pounds
Power Plants	TFE-731-2 Turbofan engines
Fuel Capacity	7,232 pounds
Range	~3,000 nautical miles
Duration	8 hours
Ceiling	45,000 feet
Cruising Speed	441 knots
Time to 41,000 feet	18 minutes

Figure 1.1 shows a photograph of the instrumented aircraft. Figure 1.2 shows three views of the aircraft with dimensions.

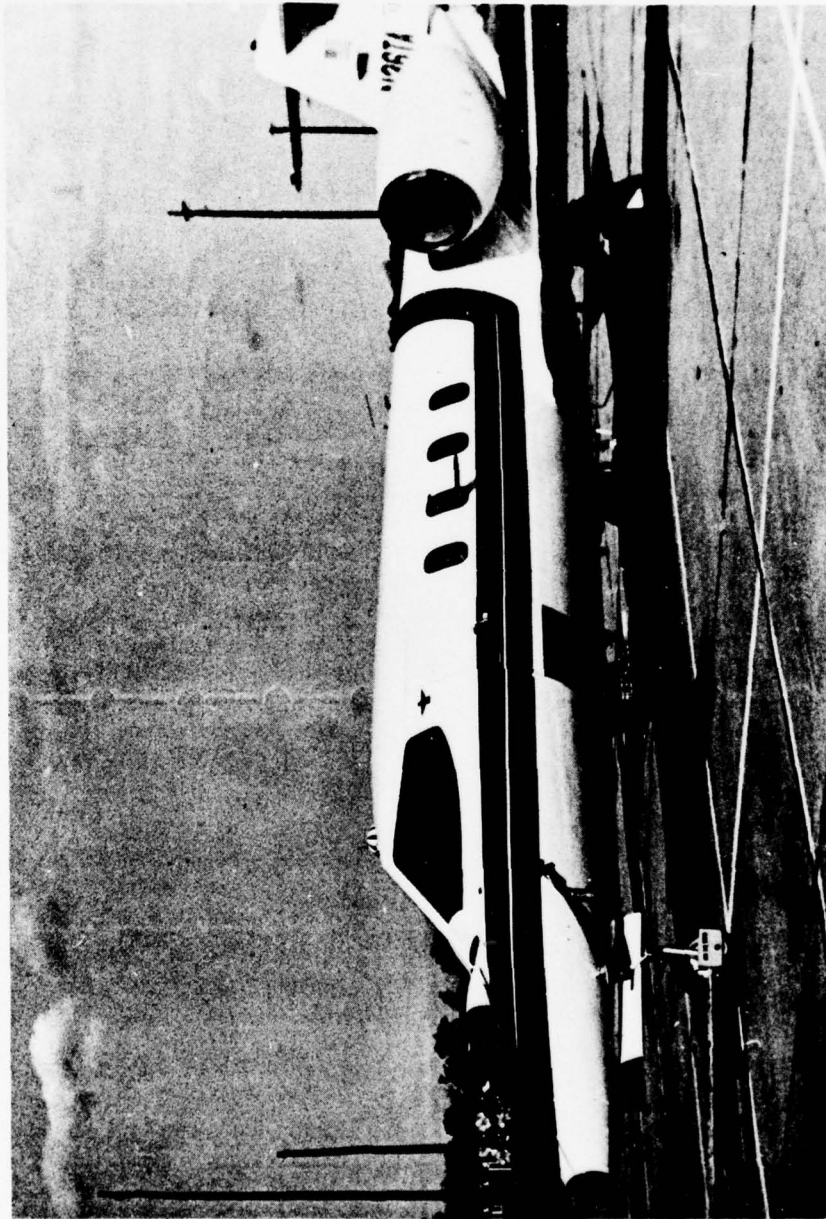

Figure 1.1 The instrumented Lear N36TA.

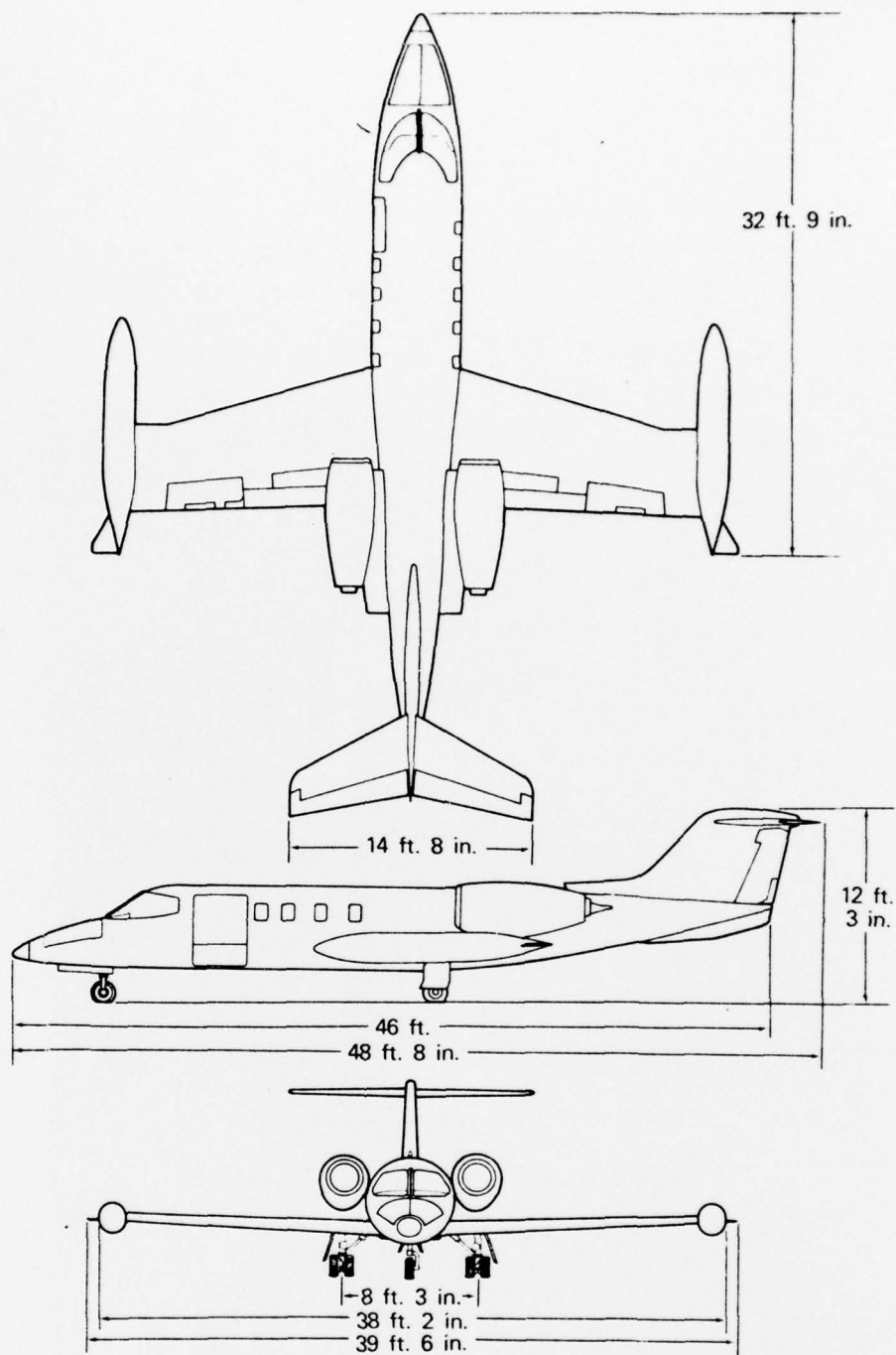

Figure 1.2. The profile of the Learjet 36 with exterior dimensions.

2.0 HAWADS DESCRIPTION

2.1 General

The HAWADS instrumentation is classified into the following general categories:

1. PMS 1D equipment
2. PMS 2D equipment
3. Flight condition sensors
4. Data handling equipment
5. Particle observations equipment
6. Audio-communications equipment
7. Total water content instrumentation
8. Power distribution equipment
9. Ground support equipment.

Each category will be treated separately.

The data flow for the HAWADS, Figure 2.1, shows that the PMS 1D and 2D data are recorded separately, with each record including time and flight condition data required to analyze the particle data.

The PMS 1D systems include the optical array probes and the axial scattering probe. Each of these measures one dimension of particles encountered. These data, together with flight condition data, are formatted in the PMS Buffer Memory System and recorded on a Kennedy 9 track, 800 bpi recorder. This system has been used for several years on this and other aircraft. It is also commonly used on other cloud physics aircraft.

The PMS 2D system includes two optical array probes which produce particle images. These high speed data are formatted, together with flight condition data in the PMS DAS-2D data acquisition system and recorded on a Pertec 9 track, 1600 bpi recorder. The 2D images are displayed in real time on a PMS Particle Image Display (PID).

Flight condition sensors consist of transducers for pressure, differential pressure, temperature, dewpoint and liquid water content.

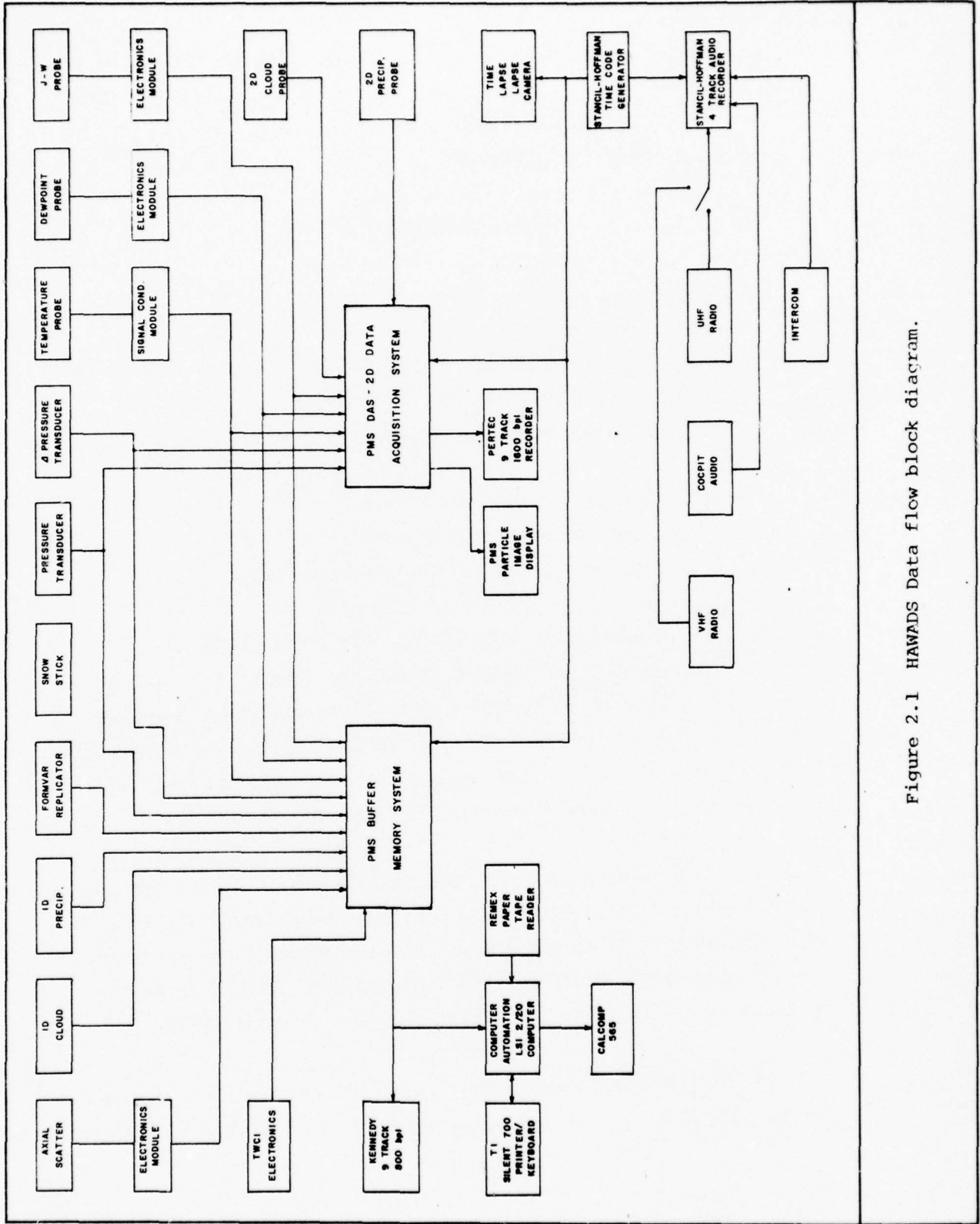

Figure 2.1 HAWADS Data flow block diagram.

The pressure and differential pressure transducers are used to derive altitude and indicated airspeed information. These five variables are fed simultaneously to the Buffer Memory System (BMS) and the 2D Data Acquisition System (DAS). Time-of-day, as generated by the Stancil-Hoffman time code generator is also recorded on both systems.

Formatted data is fed from the BMS simultaneously to the Kennedy 9 track tape recorder and to the Computer Automation computer. The tape data are saved for post flight analysis. The computer uses the same data to derive real time computed outputs which are useful in making go/no-go decisions for missile tests. These data are displayed on the TI printer and the Calcomp plotter. Programs are input to the computer via a Remex paper tape reader.

Particle observations are required in order to provide information necessary to compute liquid water content and radar reflectivity from the ID data. These observations primarily use the snowstick and the Formvar replicator. The snowstick is a simple observation stage on a heated airfoil. The Formvar replicator attempts to make replicas of particles for post flight analysis.

The audio-communications system includes an intercom system, UHF and VHF radios, a Stancil-Hoffman 4 track audio tape recorder and a time code generator. The intercom is used by the crew to communicate with each other and to enter data onto one track of the recorder. The UHF and VHF radios are used to communicate with ground crews and to record audio on a second track of the audio tape recorder. The crystal controlled time code generator feeds real time to the BMS, DAS, audio tape recorder and time lapse camera. One track of the audio tape recorder is reserved for coded real time data.

A 16mm forward-looking time lapse camera is provided to record cloud images. Real time from the time code generator is shown on the film.

A custom Total Water Content Indicator (TWCI) is installed in the Learjet. Information on this system is incomplete and not included in this report at this time.

2.2 Physical Description

The subsystems making up the HAWADS are mounted in standard electronics racks in the cabin. The floor plan of the modified airplane is shown in Figure 2.2. Most of the instrumentation is mounted along the right side. One rack, three inverters and the TWCI tanks occupy the rear of the cabin. Sensors are mounted on aluminum plates in the forward window spaces. The two HAWADS crew seats are faced forward and aft for easy access to all of the equipment.

The vertical view of the equipment racks is shown in Figure 2.3 and 2.4. The racks are mounted on an aluminum angle structure along the right side and aft end of the cabin, a portion of which is shown in Figure 2.4.

The probes are mounted on the aircraft as shown in Figure 2.5. The window mounted probes are also illustrated in Figure 2.2. They are directly ahead of the fanjet engines, so particular attention must be given to deicing equipment to avoid engine damage. The PMS 1D probes are mounted on the nose, and also pose a potential icing hazard. The 2D probes are in the tiptanks.

2.3 PMS 1D System

The 1D system consists of the 1D probes, the recording system and the flight condition sensors. These are connected as shown in Figure 2.6. The relationship of the computer system is also shown.

2.3.1 Axial Scattering Probe. The Axial Scattering Probe (ASP) measures optical forward scattering from small particles in an isokinetic sample volume to determine particle size. Dual photodiode detectors are used to verify that the particles are in the sample volume. Pulse height detection circuitry classifies the particle signals into fifteen size bins. The size bins are read out by the data acquisition system at one second intervals.

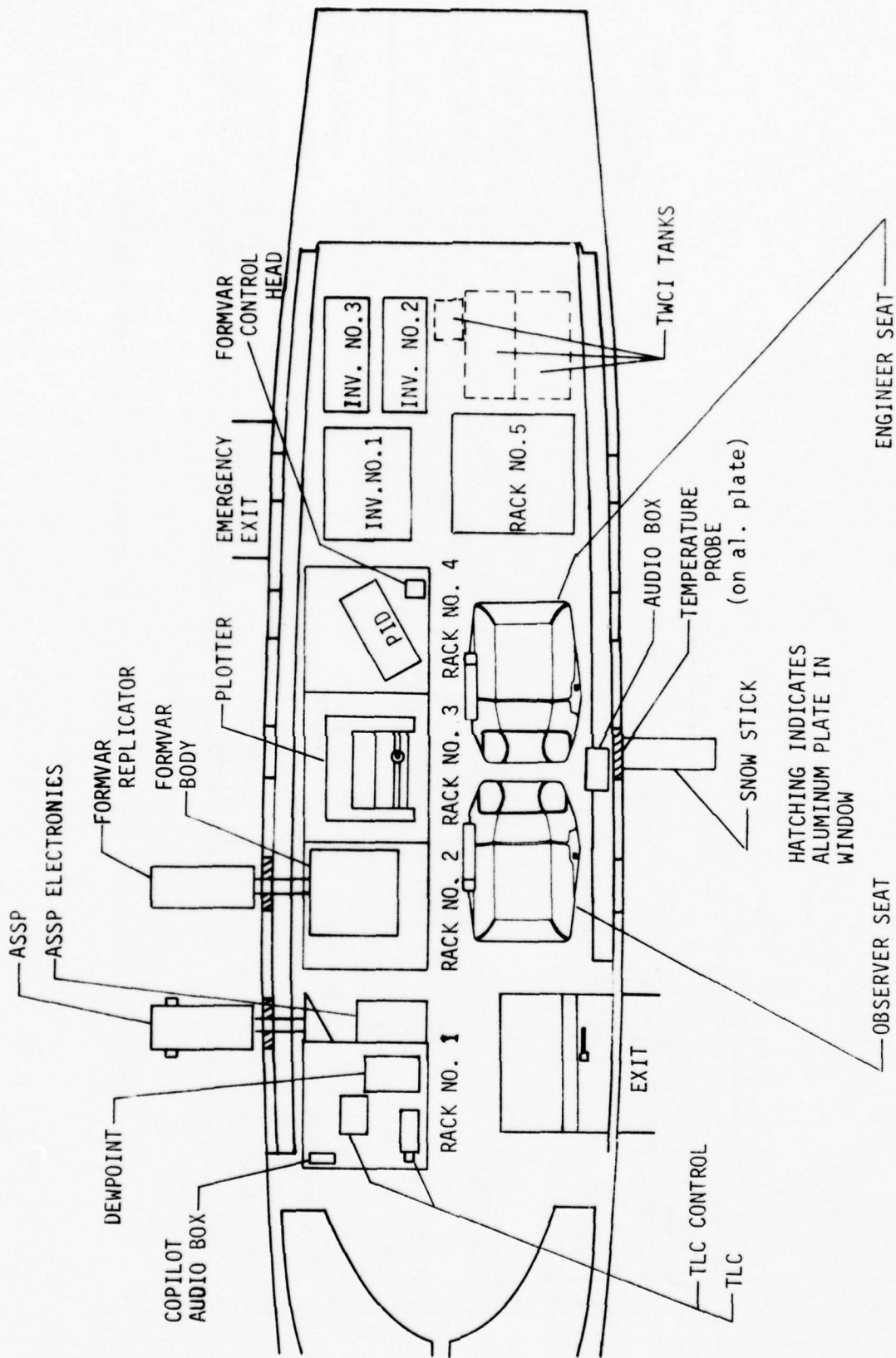

Figure 2.2 The arrangement of equipment in the cabin.

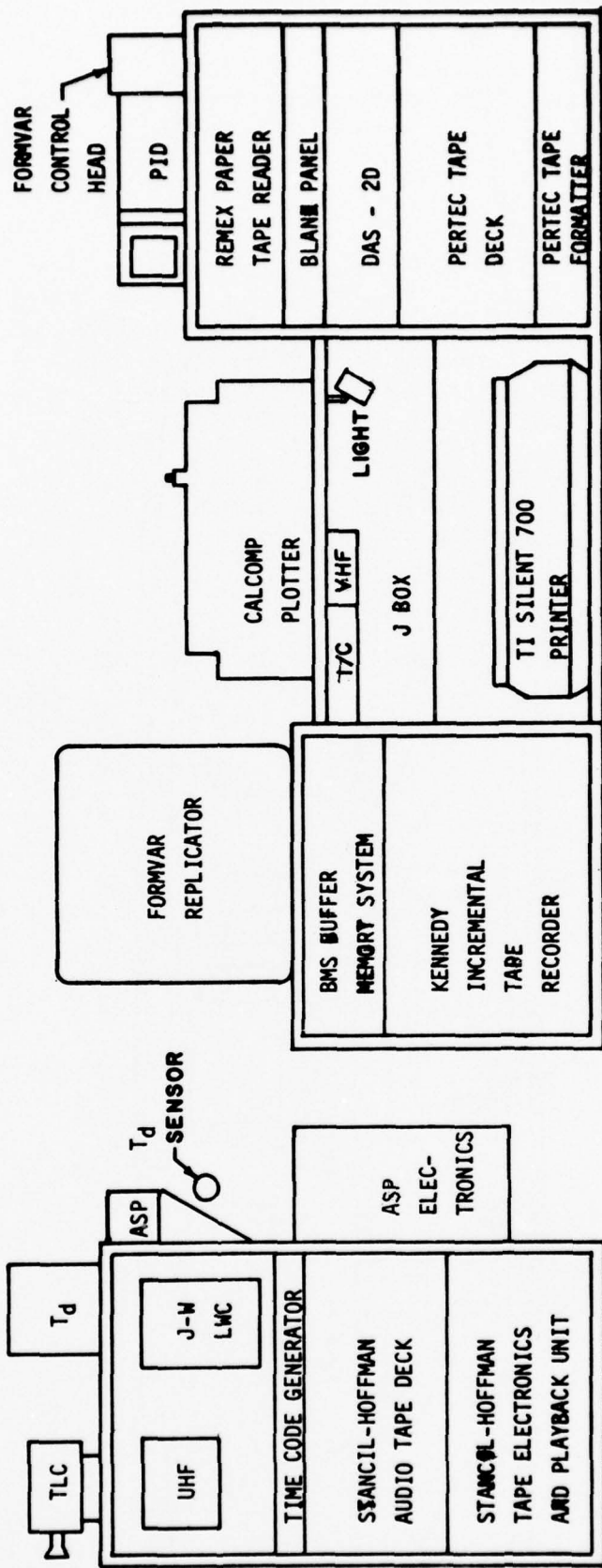

Figure 2.3 View of electronic systems in racks 1-4 along the right side of the cabin.

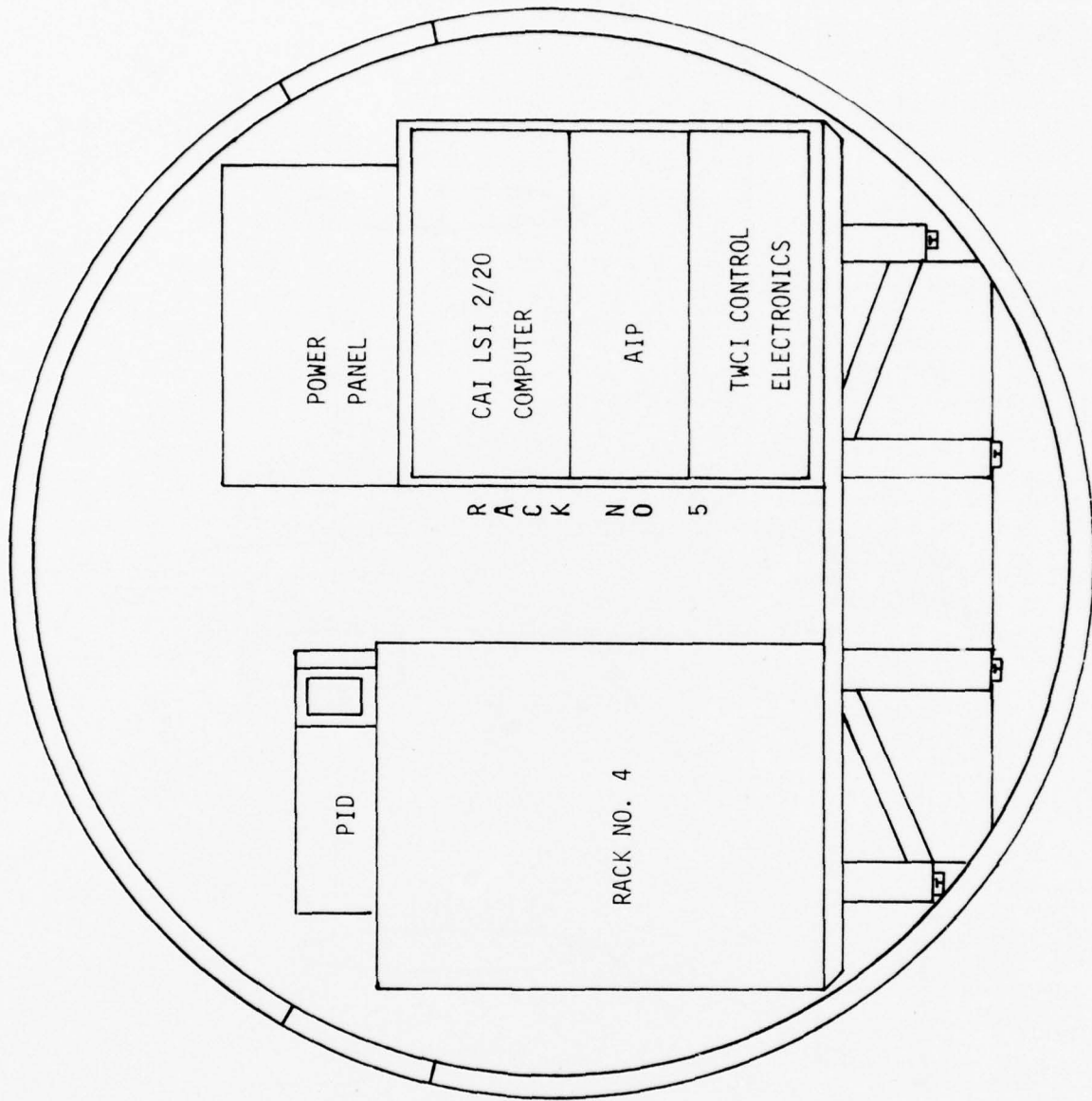

Figure 2.4 View to aft of cabin showing Rack No. 5.

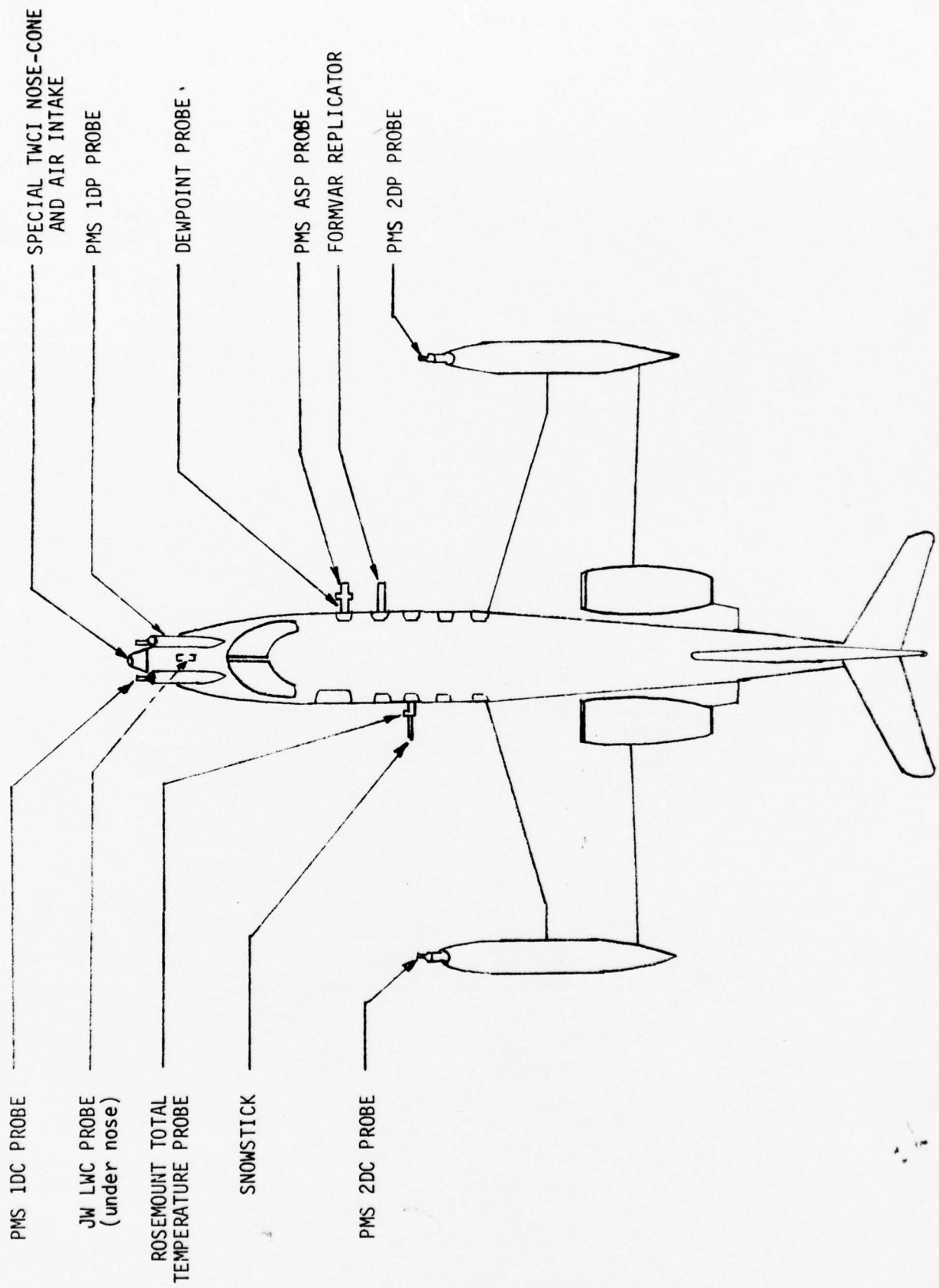

Figure 2.5 IIAWADS externally mounted instrumentation.

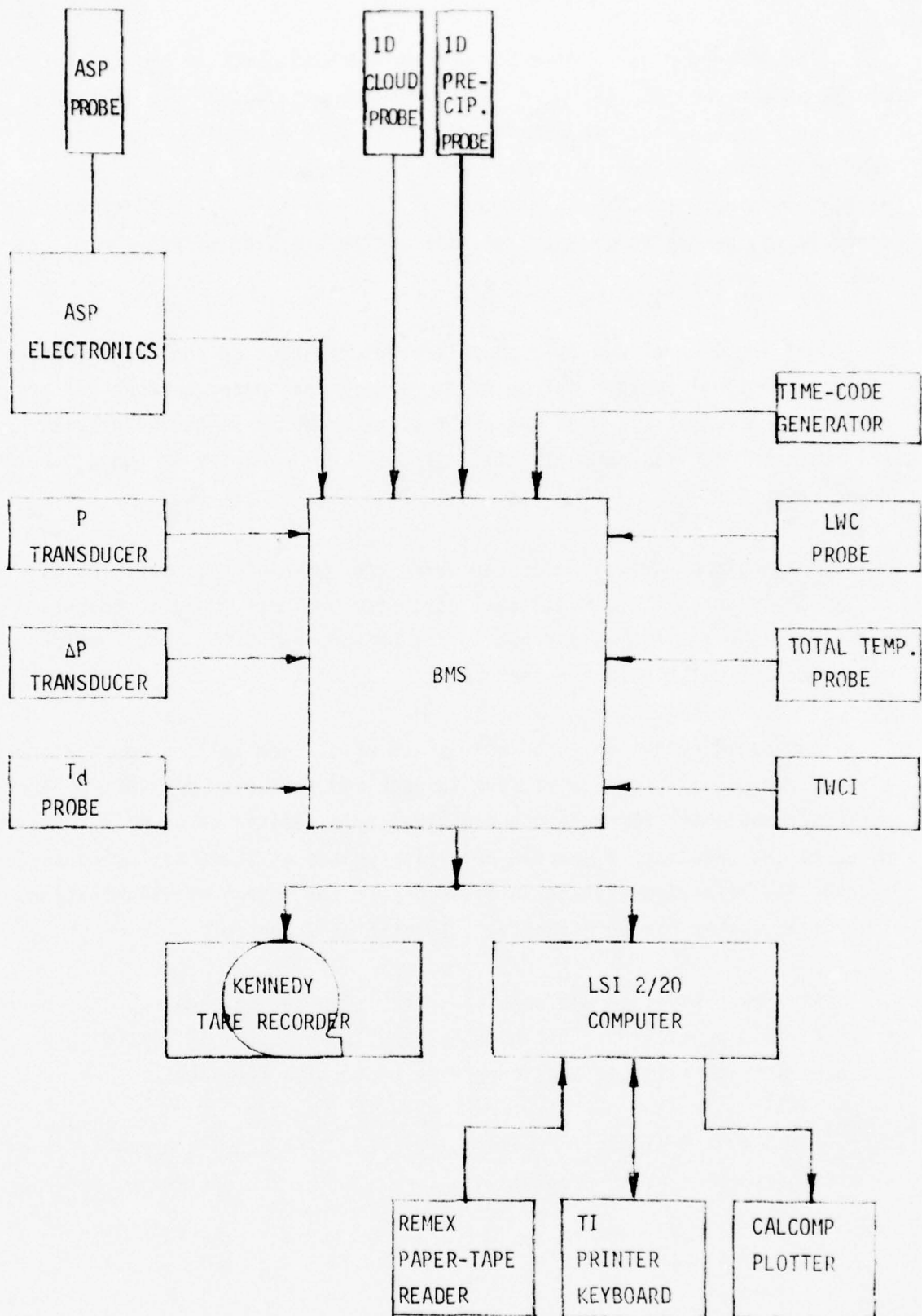

Figure 2.6 1D System, Block Diagram

The ASP probe is mounted through an aluminum plate in the right forward window of the Learjet, as shown in Figures 2.2 and 2.5. A streamlined cross-section has been provided to eliminate Mach buzz effects at high cruise speeds. Because of vibration at high Mach numbers and noticeable drag, this probe is normally removed for ferry flights. The electronics circuitry is contained in a box mounted on the aft side of rack No. 1, as shown in Figure 2.3.

Deicing is provided by a propellor deicing boot on the leading edge of the elliptical section of the probe. Additional patch heaters are provided at the outboard end of the probe. The probe is sealed with putty on the inside of the aluminum plate to maintain the integrity of the aircraft pressure hull.

The logic circuitry necessary to reject out-of-focus particles is contained in the probe. Additional circuitry includes logic to channel the particle size information out to the BMS and reset the input buffer memory on the pulse height detector.

The pulse height detector uses a set of sixteen voltage comparators and latches. The reference voltage to each comparator is provided by the reference photodetector module and divided by a resistance divider. The pulse height detector is capable of sizing pulses as short as 100 nanoseconds. Because its reference voltage is divided from the source of illumination, the entire system has an effective automatic gain control.

All power supplies are modular units. The low voltage supplies have short circuit protection. The high voltage laser supply is potted to avoid arc-over at high altitude and to provide protection from shock.

The ASP is designed for water particles. The Learjet normally flies at altitudes where water droplets are rare. Since the scattering function

of ice crystals is poorly understood, the ASP is only used to indicate relative numbers but is normally not relied upon for determining mass of ice crystals.

2.3.2 1D Cloud and 1D Precipitation Probes. These optical array spectrometer probes are manufactured by Particle Measuring Systems, Inc. They count and size particles by imaging the shadow of each particle on an array of photodiodes. A helium-neon laser is used with condensing and imaging optics to focus the shadow of a particle lying within the sample volume on an array of 24 photodiode elements spaced 200 microns apart. The laser light beam is passed between two optical arms in the airstream. A particle passing through the beam casts a shadow on the photodiode array. Photodetectors and logic circuitry convert the signal from the photodiodes occulted during a particle shadow transit into a count of the number shadowed for each particle. This count effectively measures the lateral dimension of the particle. Particles shadowing the end diodes are rejected because they are not entirely contained in the sample volume. The count data are stored in the probe and read out by the BMS at one second intervals.

Two configurations of the optics have been developed to cover size ranges from 20 to 300 microns and from 200 to 3,000 microns. The probe covering the smaller range is called the 1D cloud probe (1DC). The other probe covers the larger range and is known as the 1D precipitation probe (1DP). The combined size is sufficient to determine the water content in dense high altitude particle environments. Although particles with diameter larger than 3 mm have been encountered, their contribution to the water content is usually not significant at high altitudes.

The sample area of the 1D probes is a function of the depth of field or the beam length, whichever is smaller, the magnification, width of the photodiode array and the particle size. In the smaller size classes, each probe configuration has adequate sample area to characterize particles

expected at altitudes above 15,000 ft. In the larger ranges, the sample area is marginally acceptable. Relatively sparse particles are not characterized with the expected accuracy because of statistical variation.

The 1D probes resolve particles into 15 size classes, uniformly distributed over the range of the probes. Although the recorded size may not be a precise measurement for non-spherical particles, studies have been completed which allow adjustments for a variety of ice crystal types.

The two 1D probes are mounted on the nose of the aircraft as shown in Figure 2.7. Short pylons provide structural support. The probes are mounted so as to align the sampling area perpendicular to the local air flow. Power and data lines are routed through the forward pressure bulkhead and along the side of the cockpit. Deicing is provided by electrical heating elements in the forward facing surfaces.

The 1D probes use a helium-neon laser with a sealed cavity configuration. The optical systems include condensing and imaging spherical elements with plain dielectric mirror positioning surfaces. The photodiode array has 200 micron spacing in either probe. The number of active photodiode elements may vary from 17 to 24; however the maximum number of size channels resolved is 15.

The photodetector modules are constructed using two cascaded Teledyne Philbrick amplifiers. The photodetector modules discriminate the shadowing events of the individual photodiode elements and provide the appropriate logic output signals. The modules are designed to operate over at least an order of magnitude variation in light level.

The necessary logic to determine the number of photodiodes occulted during a particle shadow transit include logic to channel the particle sizes out through the BMS and to reset the input buffer memory on the photodetector modules.



Figure 2.7 The 1D Probes on the nose of the Learjet.

Specifications and other details are provided in the vendor manuals. Further information on the operation of these probes has been given by Knollenberg (1976).

2.3.3 Buffer Memory System. The Buffer Memory System (BMS) is the data acquisition system for the 1D probes and the associated analog data. The BMS is mounted with its associated recorder in rack No. 2, as shown in Figure 2.3. A photograph of the front panel of the BMS is shown in Figure 2.8.

The BMS collects data from the ASP (15 channels), the 1D cloud probe (15 channels), and the 1D precipitation probe (15 channels) at one second intervals. It also accumulates data from the flight condition sensors and the time code generator at one second intervals. All data is accumulated in the BMS, stored, formatted, and then transferred to a Kennedy incremental 9 track tape drive. The data is simultaneously transmitted to a Computer Automation LSI 2/20 minicomputer so that real time computations can be accomplished on the data. Data in the BMS is displayed on a four digit Nixie display with a thumb wheel word selector on the front panel. The addresses and contents are listed in Table 2.1.



Figure 2.8 Front panel of the BMS and Kennedy tape recorder.

TABLE 2.1
BMS DATA FORMAT

<u>PROBE</u>	<u>CHANNEL</u>	<u>CONTENTS</u>
1	0	Formvar Replicator Footage
1	1 - 15	Data counts (ASSP)
2	0	9333
2	1 - 15	Data counts (1DC)
3	0	Elapsed Time
3	1 - 15	Data counts (1DP)
AUX DATA	0	8192
	1	Pressure (Altitude)
	2	Differential Pressure (Airspeed)
	3	Temperature
	4	Dewpoint
	5	Liquid Water Content (J-W)
	6	Analog Spare
	7	TWCI Reference Frequency
	8	TWCI Sense Frequency
	9	Analog Spare
	10	Minutes and Seconds (from TCG)
	11	Hours (from TCG)
	12	Spare
	13	TWCI zero set mode
	14	TWCI Temperature
	15	TWCI Temperature

The BMS has storage capacity for input data from three separate probes plus the auxiliary data. The memory has 64 storage addresses with 16 bits of BCD storage per address. The memory uses a common shift register for two addresses. The memory is constructed from TTL logic and is capable of asynchronous read-write functions. The memory is provided with optical isolators for probe input.

The BMS also contains the necessary interface logic for sending data to the Kennedy incremental magnetic tape recorder and the computer. A standard Kennedy Model 1600-360 9 track incremental tape transport is used to record the output of the BMS. The 8½ inch reels are sufficient for over 19 hours of recording time per reel.

The input analog data is converted to digital signals by a VCO-counter type A-D converter. Digital data from the time code generator, the footage counter and other digital sources can be accommodated by four digital input channels available.

2.4 PMS 2D Systems

The 1D systems described above have certain limitations. Among these are:

1. Only the lateral particle dimensions are measured.
2. No information on ice crystal shape is provided.
3. Several different assumptions are required in computations involving complex ice particles.

Because of these limitations, a set of PMS 2D probes is included in the HAWADS.

The 2D system consists of two 2D probes, the 2D recording system and the flight condition sensors. There is no connection to the computer. The block diagram for the 2D system is shown in Figure 2.9.

2.4.1 Principles of Operation. The 2D probes are similar to the 1D systems described above except that they use a 32 element photodiode array and have a high speed data storage register which enables each photodetector element to transmit up to 1,024 bits of shadow information from each particle. Shadow information from each element is stored at a rate of up to four million bits per second as a particle shadow passes the array. This results in successive image slices as the particle passes.

Data is recorded only when particles are present, thus automatic data compression results. When no particles are present in the sample volume, the clock is used to accumulate elapsed time in time counters. When a shadow is detected by any of the 32 elements, the clock output to the time counter is stopped. Each successive clock pulse is used to shift the condition of each of the 32 diode elements to a buffer memory.

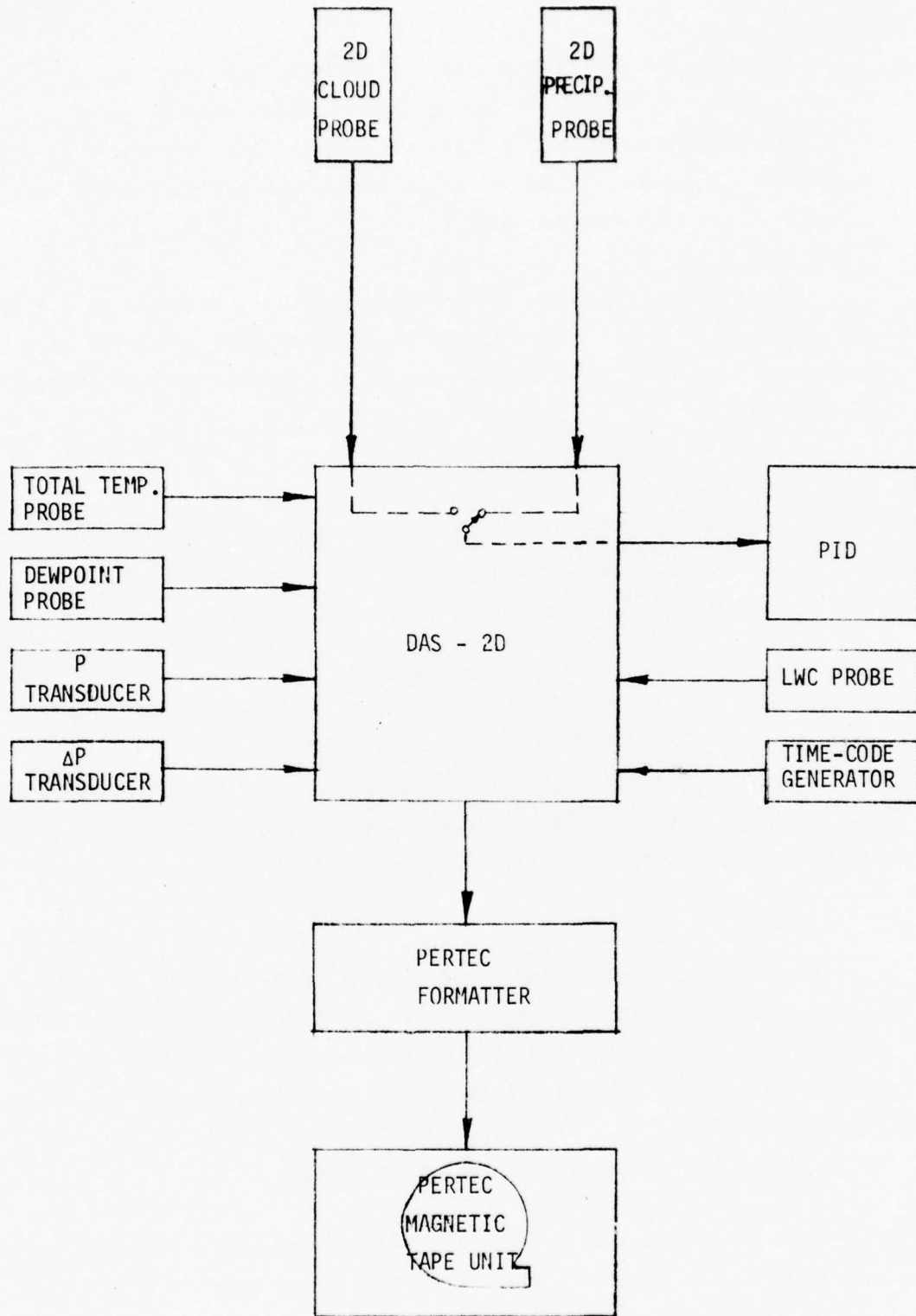

Figure 2.9 2D System, Block Diagram.

This process continues until no more elements are shadowed. The elapsed time counter is then read and reset, so that the elapsed time since the last particle encounter is written in microseconds in binary form in the first 24 bits of the 32 bit word. The remaining 8 bits are available for recording other data and can be used to identify the time ward. The clock then resumes the function of accumulating elapsed time until another particle is encountered.

The result of shifting the successive 32 bit words into the buffer register is successive image slices which effectively define the size and shape of particles encountered. An example of images of stellar dendrites is given in Figure 2.10.

The clock rate can be controlled manually by a potentiometer on the front of the DAS-2D or can be slaved to the true air speed of the aircraft. It is desirable to have the clock rate controlled so that the longitudinal sampling interval corresponds to the lateral effective diode spacing. This measure will assure that round particles produce round images.

The components used in the 2D systems are limited to four MHz data rates. This means the photodiode elements must be scanned at four million times per second or less. With 25 micron diode spacing, the four MHz data rates limit the true airspeed to 100 meters per second. Since the Learjet can not fly this slow at high altitudes, the HAWADS 2DC diode spacing has been adjusted to 40 microns. This corresponds to a true airspeed limit of 160 meters per second, which is well within the capability of the Learjet. The 2DP diode spacing must be a binary multiple of the 2DC spacing. A 160 micron spacing was selected as the most effective spacing for the 2DP probe.

2.4.2 2D Probes. The PMS 2D probes are mounted in cylindrical pods which are housed in the forward ends of the wing tip fuel tanks, as shown in Figures 2.11 and 2.12. These pods extend aft into the fuel cell so that fuel surrounds the pod, providing an effective heat sink for regulating the probe temperature. The probes are connected electrically to the DAS-2D by cables through the wings and into the cabin.

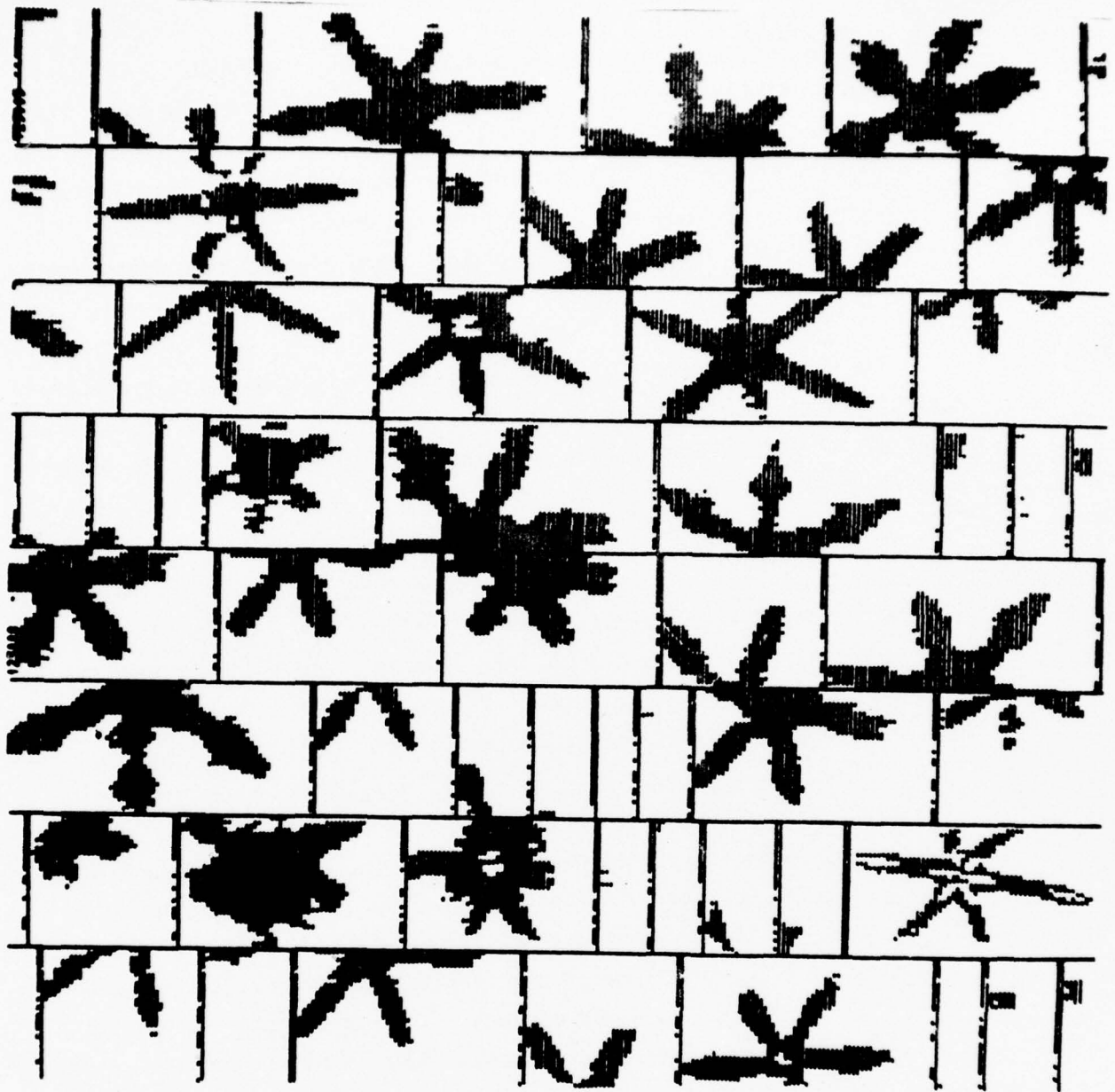

Figure 2.10 Image slice data for stellar dendrites from a PMS 2D cloud probe. The elapsed time between encounters is coded in 24 bits to the right of the image.

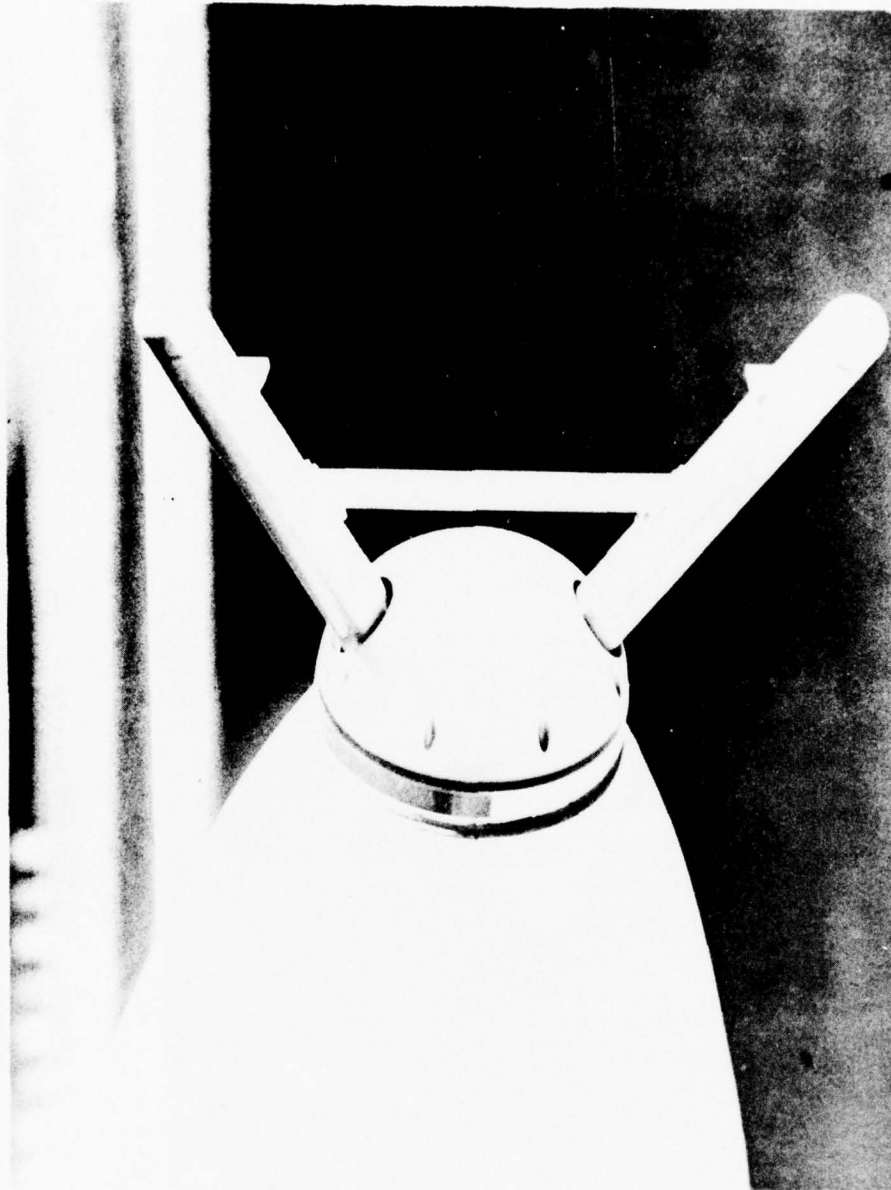

Figure 2.11 PMS 2D precipitation probe on the right wingtip fuel tank.



Figure 2.12 PMS 2D cloud Probe on the left wingtip fuel tank.

The data from each image slice is stored in a static MOS shift register which serves as the probe buffer. Actually, two MOS buffers are employed in a "ping-pong" fashion so that one can be available for loading (at a rate determined by incoming particles) while the other is used to unload the previous sampling of particles (at a rate necessary for proper writing). As long as the first buffer can be unloaded before the second buffer is half filled, no "indigestion" is encountered and the buffer roles can be alternately reversed with no loss of data.

If particles are encountered too rapidly, one buffer may not be unloaded before the other is half filled. In this case, an "overload" exists. The duration of this overload period is recorded in milliseconds for each 10 second period. This expresses the overload as a percent for that 10 second period.

2.4.3 DAS 2D. The DAS-2D is mounted in rack No. 3 (Figure 2.3 and 2.13), with the Pertec recorder and formatter.

The DAS-2D accepts data from the two 2D probes along with various other input data and makes it available for writing on computer compatible magnetic tape. Data from the 2D probes are written "on request" as determined by the particle activity encountered whereas all other data (slow data) are written at fixed rates of one record per ten seconds. Up to twelve optional differential analog inputs are sampled once per second, plus 32 counters that are sampled every 2 seconds, plus forty words of four digits (16 bits of BCD) that are recorded once every 10 seconds.

The data channels provided for slow data are:

1. Elapsed milliseconds - seven decades written at the beginning of each slow data printout.
2. 2D clock frequency in percent of 4 MHz; one word sampled once each 2 seconds and printed as word 17 in odd data lines. (Even subcom. Nos.)
3. Percent overload on 2D probes in hundredths of a percent for the 10 second interval preceding the previous slow data printout. 2 words, one for each probe, sampled once each 10 seconds. Printed out as words 1 and 2 in 2nd line of slow data printout (or record)(Subcon Line 1).



Figure 2.13 The DAS-2D and Pertec tape recorder.

4. Total 2D particle counts for each probe for the 10 second period preceding the previous slow data record. Printed out as words 3 and 4 in 2nd line of slow data record.
5. Parallel digital inputs from time code generator; 2 words (of which $1\frac{1}{2}$ are used for time) sampled once each 10 seconds, printed as words $3\frac{1}{2}$ and 4 in 1st line of slow data. Elapsed time in seconds is printed out as word $1\frac{1}{2}$ and word 2 in 1st line of slow data.

The flight condition sensors, as shown in Figure 2.1, are fed to the DAS-2D as well as the BMS. The real-time data from the time code generator are also recorded in the DAS, as well as other recording systems. Thus, the DAS-2D provides a redundant record in most respects.

The format of the DAS-2D record is shown in Table 2.2. The assignment of the analog channels, time and other data are shown according to their current configuration.

2.4.4 Particle Image Display. The particle image display (PID) consists of a four inch by five inch CRT monitor which is driven by the DAS-2D. It provides for displaying 640 slice images from either 2D probe. In the run mode this presentation will change every time a new 2D record is available from the selected 2D probe. Switching to the hold mode inhibits new updates and allows selection of any one of the four areas for expanded viewing. All 640 slices remain in storage and can be repeatedly selected for viewing as desired until the run mode is again entered, allowing real time data updates.

Each slice image contains 32 elements displayed vertically and corresponds to the condition of the 32 photodiodes in the 2D probe during one clock period with dark elements for shadowed diodes and light elements for unshadowed diodes. Each of the four rows of slices in the unexpanded display consists of 640 slices, or 160 slices in the expanded mode. The appearance of the image is very similar to the printer/plotter output shown in Figure 2.10.

2.4.5 Tape Recording. The DAS-2D system drives a Pertec Model T7640-9 9 track, 25 fps recorder/formatter with 1600 bpi density which limits the slice rate to 245 particles per second with the record length of 37,240 bytes. This particle rate is for large length particles of about 32 image slices per particle. Maximum rates for smaller particles are proportionately greater. With 600 ft. of tape available on the 7 inch reels, the maximum

particle rate can be maintained for only about eight minutes. However, normal particle rates result in recording times of over one hour.

A total of 32 slow data words are provided each second along with storage for ten such readouts before writing them on tape, such that each slow data record written on tape will consist of 320 data words plus two words of time and identification information (644 tape bytes of 8 bits each). The scan rate of once per second results in one slow data record being written every ten seconds.

Recording of data from one probe does not have to be completed before a request for recording from the other probe is received in order to provide uninterrupted particle sampling. As long as a buffer memory in a probe does not get half filled before its alternate buffer memory has been completely read out onto the tape, there will be no interruption of data in that probe. This applies to both probes.

With 600 ft. of tape per reel, about 5 minutes of data can be recorded at the maximum 2D request rate. For situations where changing tapes is not practical, a selector switch on the front of the DAS-2D is provided to limit writing 2D (image) records to 1, 2, or 10 second intervals as desired, making the minimum time per reel 4.6, 1.15 or .6 hours respectively.

Some flexibility exists for utilizing the slow data words. The arrangement provides for 12 prime analog channels, each sampled once per second plus 30 subcommutated channels, each sampled once every ten seconds. Fifteen of the 2 second sub channels are available for recording 1 second accumulations of the 15 size classes coming from the 1D probe. These data can enter the DAS as 4 address lines accompanied by a strobe signal for each particle sized in the probe. The DAS decodes the address and implements the corresponding 4 decade BCD counter in each case. After each 2 second sampling interval, the contents of all counters are dumped in parallel into output shift registers and then the counters are reset to zero for the next sampling. A similar implementation is used for the analog inputs by providing a voltage to frequency converter with corresponding counter

for each input. This amounts to an A-D converter for each channel, with each sample recorded representing an average of the input signal over the 1 second sampling interval. In the case of the eight sub-commutated analog housekeeping signals, a single counter is time shared to represent a 1 second average of 10 different inputs sequentially with each input recorded once every ten seconds.

A selectable 4 digit decimal display is provided on the front panel of the DAS-2D to allow viewing of any slow data word in the format without interfering with recording. Push-button switches are provided for controlling recording function.

The differential analog inputs in the DAS provide for analog input capability. Each module contains two channels with each channel made up of a high quality differential instrumentation amplifier followed by a voltage to frequency converter. Gains from 0.1 to 10K can be selected by mounting proper resistors. Potentiometers are included for setting offset and trimming gain as desired. The full scale frequency is 10 KHz resulting in 4 decimal digit resolution for 1 second samples. Some pertinent specifications for the differential analog inputs are:

- Differential input impedance: greater than 100 megohms
- Common mode impedance: greater than 100 megohms
- Common mode voltage range: ± 10 volts
- Common mode rejection: 100 db
- Input bias current: 50 nA
- Input offset voltage drift: 3 microvolts per degree Celsius

The true airspeed slaved 2D oscillator in the DAS provides for generating a 2D clock frequency proportional to the true airspeed so that raw image

data will have the same resolution along the flight paths as across. A voltage controlled oscillator is employed to provide a 4MHz frequency at a true airspeed of 160 meters per second (in the Learjet with 40 micron resolution along the flight path. The analog voltage for true airspeed is provided by the computer by means of a D-A converter and necessary scaling electronics. The VCO output is used directly for the 2DC probe and is divided by 4 in a counter to clock the 160 micron resolution of the 2DP probe. It is important that the image slices be sampled at the correct rate so that the particle images are not distorted. Presently, the TAS interface circuitry is not installed and the 2D oscillator is run at a constant 4 MHz rate which corresponds to a true airspeed of 160 meters per second.

A Pertec Model T7640-9 tape transport with a Model F649-40 formatter are used for recording data from the DAS-2D. This is a 9 track phase encoded system for operation at 25 ips at a density of 1600 bits per inch on standard 7 inch reels (600 ft of tape per reel). Read-after-write units are employed to allow error checking during recording. The Pertec magnetic tape system is installed in the bottom of rack No. 3, below the DAS-2D as shown in Figure 2.13.

2.5 Flight Condition Sensors

The flight condition sensors are installed to provide basic data needed for evaluating the particle information recorded on the 1D and 2D systems.

2.5.1 Pressure and Differential Pressure. A Validyne Model P24 pressure transducer is used to measure the co-pilot static pressure. The transducer is located behind the copilot's instrument panel. It produces a 0-5 VDC signal proportional to static pressure from 0-15 psi. Altitude is computed from the static pressure data.

A Validyne Model P24 differential pressure transducer is used to sense the copilot pitot-static pressure differential. A 0-5 VDC output is provided for 0-2 psid. An indicated airspeed is computed from the differential pressure. This transducer is mounted behind the copilot's instrument panel.

2.5.2 Dewpoint. The Dewpoint measurement uses an EG&G Model 137 dewpoint system. It employs an absolute sensing device which cools a mirrored surface until fog forms and then maintains the surface temperature at the fog threshold. The temperature of the mirror is, by definition, the dewpoint temperature. The probe is mounted on the aluminum plate in the right forward cabin window. The electronics module is mounted on top of rack No. 1 as shown in Figures 2.2 and 2.3. Balancing controls and the balancing indicator are provided. No de-icing is required for the system.

2.5.3 Temperature. The temperature measurement uses a Rosemount Model 102 total temperature sensor, mounted on the aluminum plate on the second left cabin window, as shown in Figure 2.14. It employs a platinum resistance element and a flow duct designed to achieve a constant recovery factor. Flow within the duct is controlled by boundary layer bleed ports to improve time response and to separate water droplets from the airstream passing the sensor element. The housing is equipped with 28 vdc deicing heaters. A Rosemount Model 510BF79 signal conditioning amplifier is used to produce a linear 0-5 VDC signal proportional to temperature from -70°C to $+50^{\circ}\text{C}$. This amplifier is mounted in the bottom of rack No. 5. No adjustments or controls are available with the system.

2.5.4 Liquid Water Content. A Johnson-Williams Model LWH liquid water content meter is used to measure the concentration of water in cloud sized droplets. The probe is mounted under the nose of the Lear as shown in Figure 2.15. The probe uses calibrated resistance wires, normal and parallel to the flow, to measure the amount of cooling due to evaporating impinging water droplets. The probe is electrically deiced. It has a range of $0-6 \text{ g/m}^3$, but accuracy is uncertain and response is degraded outside of a 10-50 micron range. A power supply for the probe is mounted

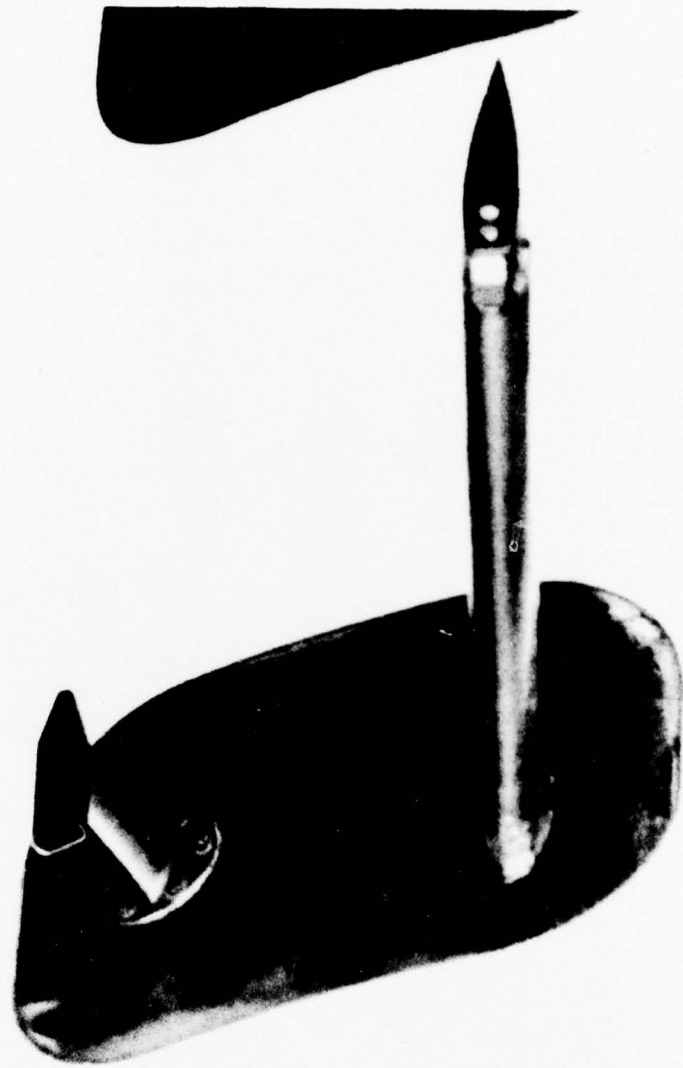

Figure 2.14 The Rosemount Total Temperature Sensor and snow stick on the second left cabin window.

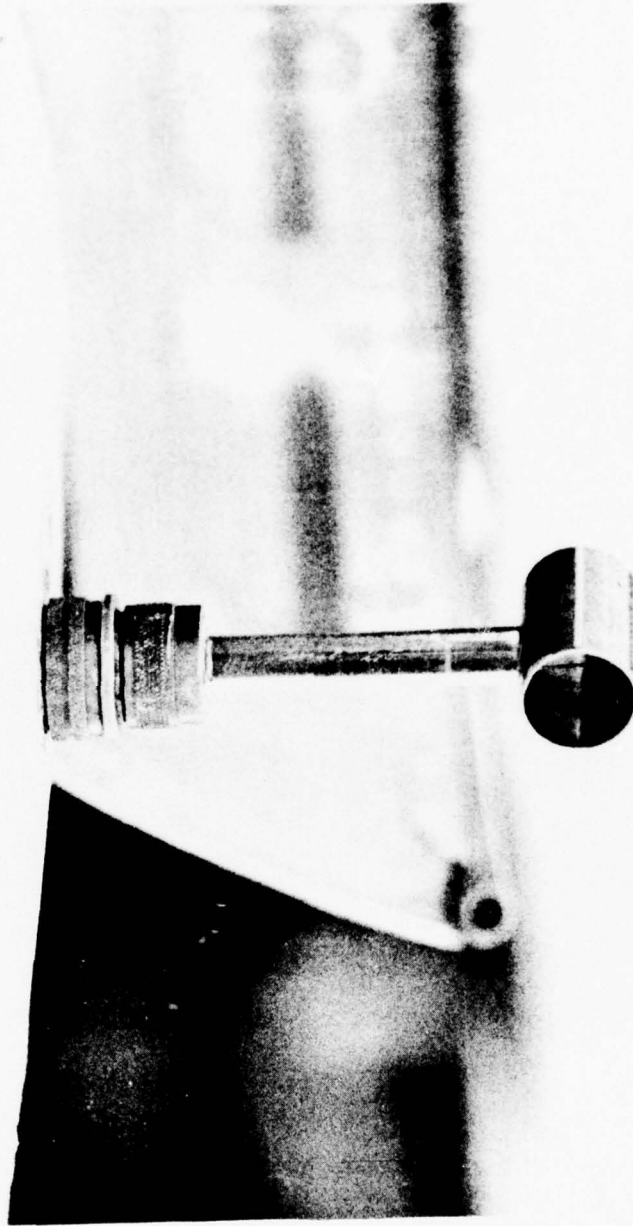

Figure 2.15 The Johnson-Williams Liquid Water Content Meter under the nose of the Learjet.

in the nose avionics bay of the Learjet. The electronics module is mounted in the top of instrument rack No. 1 and is shown in Figure 2.3. Controls are provided to set the zero signal level and to adjust the airspeed calibration factor. Two scales are provided on the built-in meter. Details of calibration, maintenance and operation are given in the vendor manual.

2.5.5 Time Code Generator. The Stancil-Hoffman Model TG2400XB time code generator, mounted in rack No. 1, as shown in Figure 2.3, is used to generate a binary time code signal which is recorded on 1 track of the recorder. A 6 digit lighted display continuously indicates the time in hours, minutes, and seconds on a 24 hour time format.

The addition of a battery emergency power supply allows uninterrupted operation during power failures. This is accomplished by the use of a nickel-cadmium battery pack consisting of four 1.2 volt cells connected in series which is constantly charged at a controlled rate whenever the generator is connected to the AC power lines. When power is removed, either gradually or suddenly, a smooth transition to battery power takes place without losing or upsetting the indicated time. A similar transition to AC power takes place automatically when the power returns.

The lighted digital display continues to operate during battery operation but at a lower brilliance to conserve power. At the battery end-point, just prior to where the generator will no longer operate properly, the display is barely visible.

The battery is fully charged after operating on AC power for approximately 15 hours, and will then operate the generator during power failures

for at least 2 hours. However, in many cases it will operate as long as 3 to 4 hours before the batteries become discharged.

Power is connected whenever it is applied to the receptacle at the rear of the unit. The battery switch at the left end of the panel must be placed on the ON position to arm the unit for emergency power.

2.6 Data Processing System

The data processing system installed in the aircraft includes a Computer Automation LSI 2/20 digital computer, a Calcomp plotter, a TI printer/keyboard, and a Remex paper tape reader. The system block diagram is shown in Figure 2.16. The I/O devices generate hard-copy displays, both graphically and numerically, of several real-time cloud parameters. These enable in-flight monitoring of the performance of the sensor system and the characteristics of the environment being sampled. Pertinent information can then be relayed to the test directors to assist timely decisions about the conduct of the mission.

2.6.1 LSI 2/20 Computer. The heart of the data processing system is the LSI 2/20 16 bit computer (installed in rack No. 5, Figure 2.4). The computer has non-volatile 32K of core memory and is programmable from its front panel console, the Remex paper tape reader, or the TI keyboard. The real time programs use Fortran IV for arithmetic computations and assembly language for control and raw data transfer. Computer Automation supplies the basic executive program and library subroutines.

User generated programs normally are compiled and linked to the CAI "operating system" and a binary object code generated using either magnetic tape or disc peripheral devices. Since the HAWADS system provides neither, all new programs and changes to the existing programs must be made at another facility. A binary paper tape must be punched so it can be loaded into the computer via the paper tape reader.

Real time patches can be made from the computer console (or the TI keyboard using the "Debug" routine) but no paper tape copy can be made with the present configuration.

Instrumentation system data and status is input to the computer via an interface module connected to the BMS. The 1D particle data and the flight condition sensor data are used to compute true airspeed, altitude, temperature, dewpoint, pressure, time, total number of particles detected by all the 1D probes, water content in particle density, and radar reflectivity (Z).

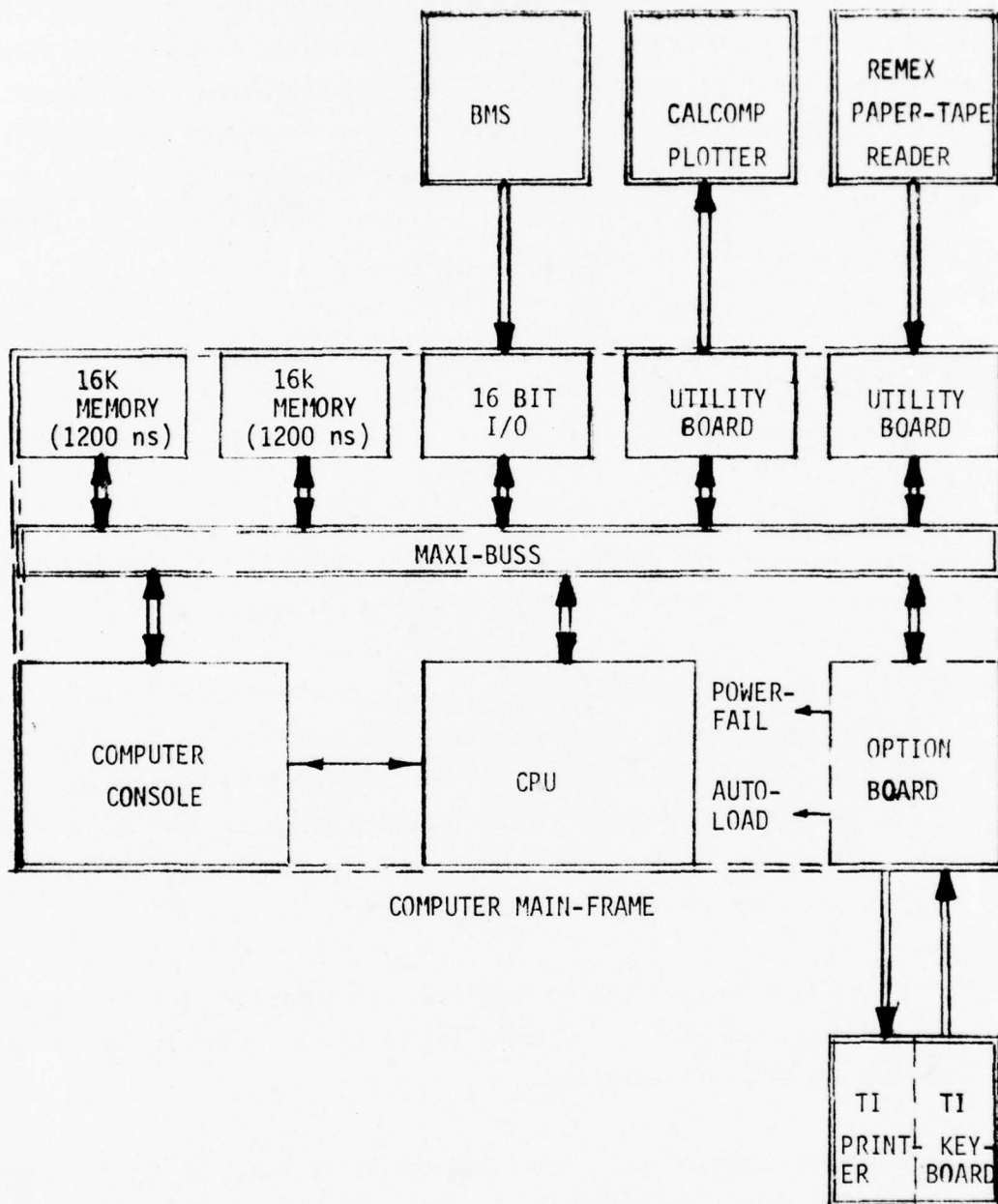

Figure 2.16 Data Processing System, Block Diagram.

The computer continuously outputs a running four second average to the Calcomp plotter (see Figure 2.17) which displays:

1. Time-of-day (sample time)
2. Crystal type
3. Water content for each probe: ASP, 1DC, 1DP
4. Total water content for all probes.

A variable length average is computed on command from the TI keyboard and is output to the TI printer (see Figure 2.18) which displays:

1. Start and stop time of sample
2. Crystal type
3. Altitude
4. True air speed
5. Pressure
6. Temperature
7. Dewpoint
8. Particle count, density, water content, and reflectivity for each size bin for each 1D probe.

2.6.2 Real Time Computer Program. The computer manufacturer provides the basic operating building-block programs for executive, arithmetic routines, and input-output drivers. Additional software development tools, such as Debug, and a complete library of diagnostics, are also provided. The user needs to add only those special routines necessary for his specific application.

The HAWADS real time program contains all the basic operating packages provided by Computer Automation plus special software which collects the 1D cloud probe and flight condition sensor data from the BMS, accepts commands from the TI keyboard, computes cloud physics data, and outputs the data to the Calcomp plotter and the TI printer. The basic program flow diagram is shown in Figure 2.19. The real time program is written to respond to four hardware interrupts: Power-fail/restart (priority 1), BMS data ready (priority 2), keyboard input (priority 3), and computer console interrupt (priority 4).

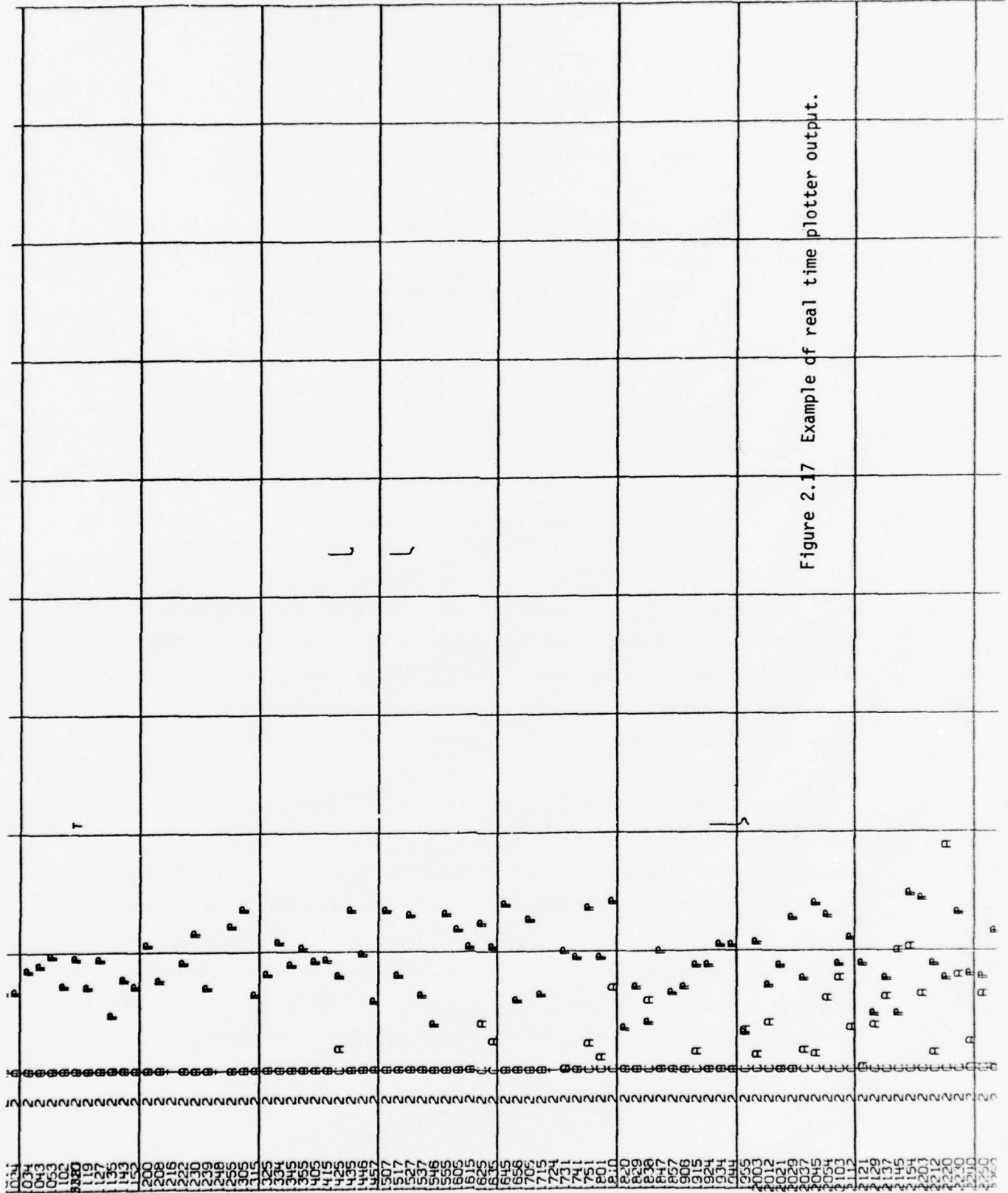

Figure 2.17 Example of real time plotter output.

LEAR-36 FLIGHT DATA

1/24/77 20:19:17 TO 20:23:16 ELAPSED TIME 4:0 TYPE: SS
 ALT 13026.FT/ 3970.M TAS 177.KT/ 91.M/S P 618.MB T -8.5C TD-49.7C
 IAS 141.KT/ 73.M/S
 SLOPE 1.025/1.025 INTCP 0.364/0.364 COEF 0.400/0.370 EXP 0.782/0.670

SIZE	COUNT	NO/M**3	LWC	MG/M3	Z
2	795.	104407.	0.0	0.17E-10	
4	5927.	778394.	0.0	0.50E-08	
6	11019.	1447127.	0.2	0.90E-07	
8	9557.	1255122.	0.4	0.40E-06	
10	8780.	1153078.	0.6	0.13E-05	
12	6843.	898692.	0.9	0.30E-05	
14	6087.	799407.	1.2	0.65E-05	
16	4375.	574570.	1.3	0.10E-04	
18	3361.	441401.	1.4	0.16E-04	
20	2211.	290371.	1.2	0.19E-04	
22	1740.	228514.	1.3	0.27E-04	
24	1348.	177033.	1.3	0.34E-04	
26	991.	130148.	1.2	0.41E-04	
28	824.	108216.	1.2	0.52E-04	
30	692.	90880.	1.3	0.66E-04	
ASPSUM			13.5	0.28E-03	
20	743.	77410.	0.6	0.16E-04	
40	547.	14926.	0.4	0.41E-04	
60	660.	8404.	0.5	0.12E-03	
80	678.	5112.	0.6	0.25E-03	
100	662.	3372.	0.6	0.43E-03	
120	616.	2307.	0.6	0.66E-03	
140	488.	1427.	0.6	0.82E-03	
160	259.	649.	0.3	0.67E-03	
180	174.	467.	0.3	0.83E-03	
200	75.	217.	0.2	0.62E-03	
220	66.	207.	0.2	0.91E-03	
240	46.	157.	0.2	0.10E-02	
260	49.	184.	0.3	0.17E-02	
280	46.	192.	0.4	0.25E-02	
300	57.	268.	0.6	0.48E-02	
1DCSUM	5166.	115297.	6.5	0.15E-01	
200	9815.	1676.	2.8	0.17E-01	
400	13246.	2370.	14.4	0.32E 00	
600	5278.	992.	12.4	0.57E 00	
800	2123.	420.	8.9	0.68E 00	
1000	819.	171.	5.5	0.64E 00	
1200	366.	81.	3.7	0.60E 00	
1400	165.	39.	2.3	0.52E 00	
1600	62.	16.	1.2	0.35E 00	
1800	29.	8.	0.8	0.27E 00	
2000	11.	3.	0.4	0.17E 00	
2200	7.	2.	0.3	0.17E 00	
2400	1.	0.	0.1	0.37E-01	
2600	3.	1.	0.2	0.17E 00	
2800	0.	0.	0.0	0.0	
3000	0.	0.	0.0	0.0	
1DPSUM	31925.	5779.	52.9	0.45E 01	
TOTAL	37091.	15225.	56.6	0.45E 01	
MK=	26.68	MK2=	25.69	F=	0.422 S= 0.2761E 03

Figure 2.18 Sample output from the TI printer.

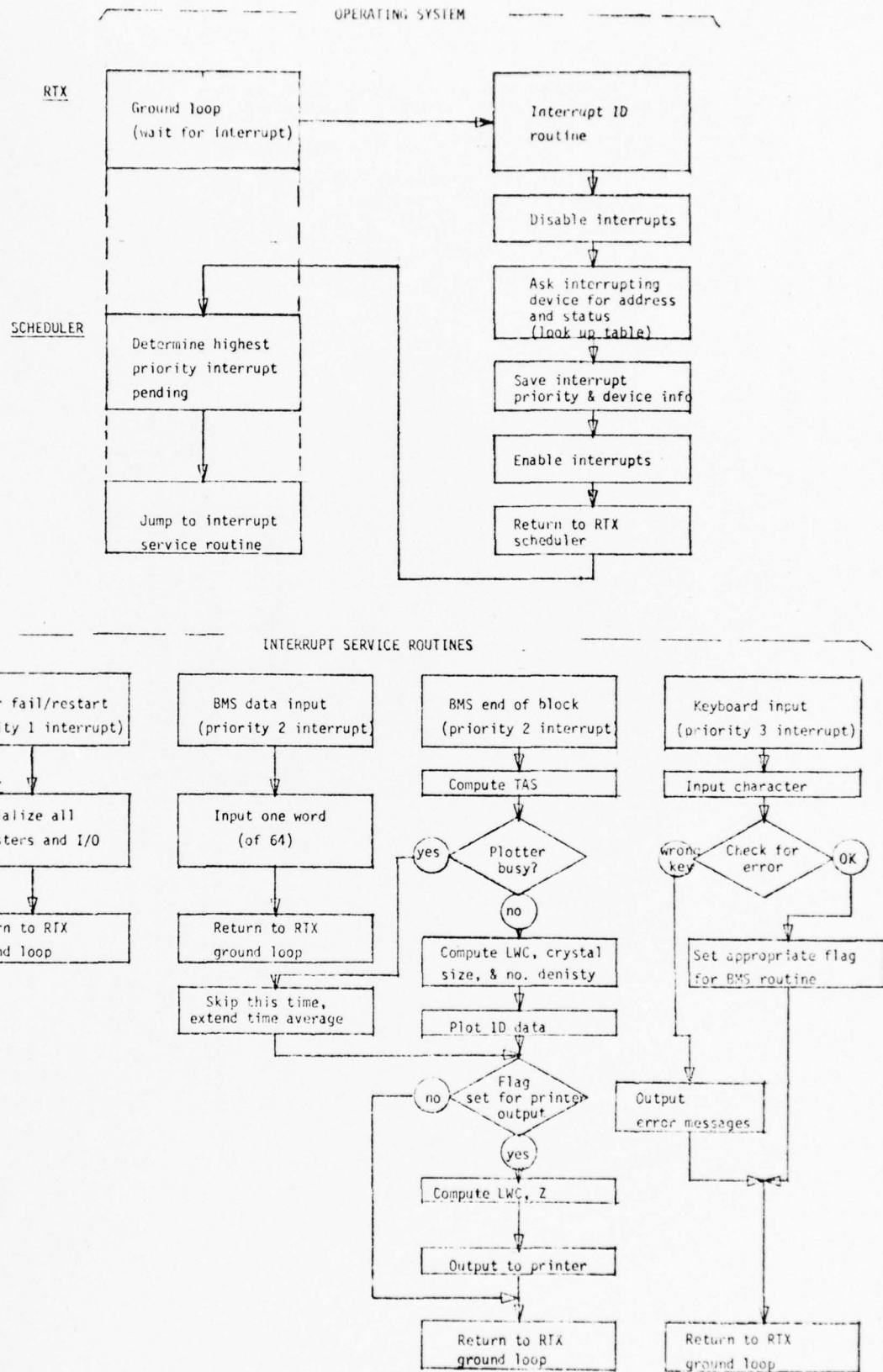

Figure 2.19 Flow diagram, real time program.

When power is brought up on the computer, a hardware feature causes the machine to execute a preloaded start-up routine (stored in non-volatile memory) which initializes all counters, data-storage locations, and input-output interfaces. Then the real time "supervisor", RTX, is called which enables external interrupts and places the computer program in a "wait" or ground loop mode looking for an interrupt to occur. When a BMS interrupt is received (at a 1 per second rate), the program branches to the BMS service routine which inputs and formats the BMS data, performs the real time computations, and then outputs the data to the plotter. The service routine then checks to see whether any special mode has been previously selected from the keyboard, and, if so, outputs to the printer accordingly. Note that the BMS data input does not require a "ready-response" from the computer to initiate transfer. The software must be prepared to accommodate the BMS or risk loss of data for that one second block. When the BMS data output is completed, the service routine returns program control to the "ground loop" and waits for the next interrupt.

When an interrupt is received from the keyboard, the command from the operator is stored where it can be retrieved and executed during the next BMS interrupt routine. The keyboard service routine then returns control to the ground loop. Valid keyboard commands include:

- L - Prints out date, time, temperature, dewpoint, altitude, and true air speed
- H - Prints output heading
- R - Prints -number of power fail/restarts
 -number of data sync. errors
 -number of BMS time-outs
- T - Simulates BMS 64 word data block
- B - Outputs entire 64 word BMS input buffer
- Z - Calls Debug routine and allows loading instructions into the computer from the keyboard
- S - Starts compilation of 1D data for time-average sample run
- E - Ends sample run, begins printout of 1D sample data
- 1-9 - Define type of ice crystal.

Note that if a higher priority interrupt occurs during servicing of a lower priority interrupt, the program is designed to immediately save the information being processed, jump to and service the higher interrupt, and then return to the original place.

2.6.3 TI Printer/Keyboard. A Texas Instruments Silent 700 printer is also tied into the computer for inputting ice crystal types for computational purposes and to request a "start of sample" (S) and an "end of sample" (E).

During the time interval between start and stop of sample, the computer will run computations on all of the data that comes in, providing real time cloud physics information to the on-board meteorologist. At the conclusion of the sample period, the processed 1D data is printed out. One of the formats selectable for output is shown in Figure 2.18.

The Silent 700, shown in Figure 2.20 is a self-contained local-controlled electronic data terminal designed for use in a wide variety of telecommunications systems. Silent electronic printing is achieved using a dot matrix on a monolithic, solid-state printhead which prints characters across the page. The matrix is composed of separate solid-state heating elements, each electronically controlled. A voltage is applied to the proper character element, transferring thermal energy to the heat-sensitive paper, thus creating a visible image.

The model 733 KSR is an ASCII-coded, keyboard send-receive data terminal, similar in function to conventional tape punch data terminals. The TI 733 KSR is capable of transmitting, receiving, and printing the ASCII code and character set at switch-selectable speeds of 10, 15, or 30 characters per second. The HAWADS unit is set up for 30 characters per second.

The following options are available with the model 733 KSR:

- a. Answer-back memory
- b. Auto answer control
- c. TTY line interface series
- d. Automatic device control (line-disconnect function)
- e. Mode M line interface
- f. Full (upper and lowercase) ASCII keyboard
- g. Acoustic coupler.

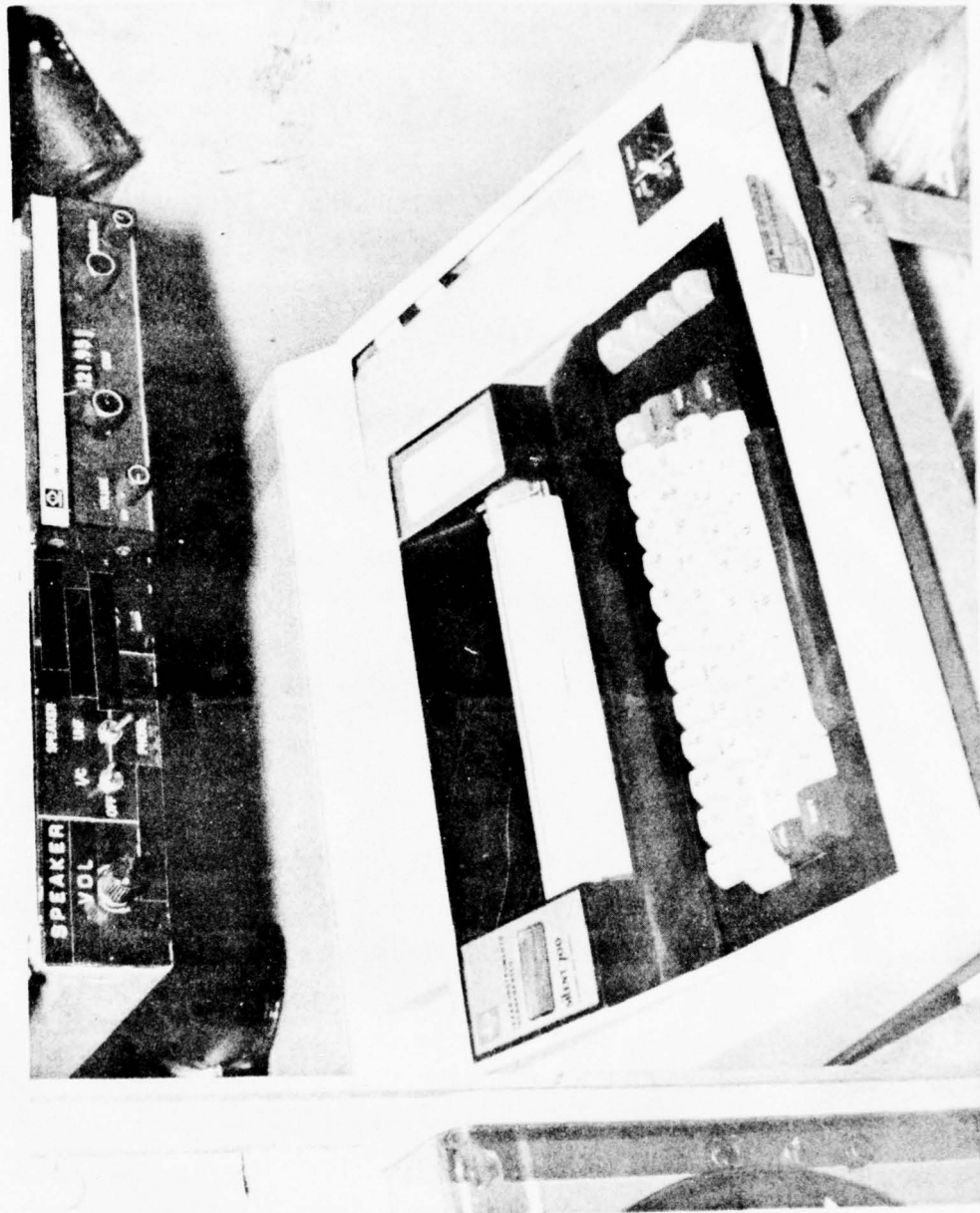

Figure 2.20 The TI Keyboard, VHF, and audio selector box.

2.6.4 Calcomp Plotter. A Calcomp 565 drum plotter is used in the HAWADS to provide a continuous pictorial representation of cloud data from the 1D probes sampled during flight. A typical plotter output is shown in Figure 2.17.

2.6.5 Remex Paper Tape Reader. A Remex paper tape reader is used to read both real time and diagnostic programs into the computer. It is installed in the top of rack No. 4 as shown in Figure 2.3.

The Remex Model RR-6300BBX/66X, punched tape reader is designed to operate in data processing systems using 8 channel punched tape. The reader converts the information stored in the form of punched holes into electronic signals.

A plug-in circuit card provides the logic control for tape movement in either direction from external signals or the front panel switches. The outputs from the card control a step motor which drives the tape via a sprocket wheel. Data outputs are generated from the photocell readhead. As tape passes over the photocells, changes in light intensity are sensed by the photocells, amplified, and brought out to an external connector. The card also contains the power supplies for the lamp, circuits and the step motor.

2.7 Formvar Replicator

The computation of liquid water content from the PMS 1D or 2D data requires a knowledge of the type of hydrometeors encountered. The Formvar replicator is designed to provide a permanent record of a sample of hydrometeors. Formvar is commonly used to make replicas of hydrometeors. It is a clear plastic substance which is used to coat microscope slides or other clear carriers used for sampling. When a hydrometeor is dropped onto a layer of liquid Formvar, the surface tension causes it to migrate around the hydrometeor, encasing it in a thin layer of Formvar. When it dries, the water can evaporate through the porous shell, leaving a hollow casting of the particle shape. The MRI Formvar replicator is designed to automate this process. Clear Mylar film is transported through the sampling arm

which extends through the second right cabin window. It is coated with liquid Formvar just before passing a sampling slit in the leading edge of the sampling arm. The tape is then returned to a drying section and collected on a takeup spool. A footage counter is used to measure the amount of film used. A digital output from the counter is provided for the BMS. This record enables the operator to return to a particular point of interest on the film.

The Formvar replicator is made up of five systems as follows:

1. The 16 mm film transport including the supply and takeup reels, tensioning motors, transport drive motor and the series of spools and guides which route the film through the instrument
2. The Formvar system, including the supply tank, peristaltic pump, pen applicator and the connecting valves and tubing
3. The sampling boom with its heated leading edge and 1mm wide sampling port
4. The drier housing, heaters and air ducts
5. The control module and electronics with a footage counter.

A number of difficulties are to be expected in using the Formvar replicator. First, it is relatively complex and difficult to operate. Reliability is low and considerable cleaning and maintenance is required.

Particles larger than about 200 microns break up when they impact the replicator tape. The fast speed of the Learjet further complicate this problem. Interpretation of the broken particles is difficult and imprecise.

The speed of the Learjet made it necessary to increase the slenderness ratio of the sampling boom by extending the leading edge about 2.25 inches away from the Formvar tape. As a result, very few particles ever impact the film and essentially none are recognizable as ice crystal types.

The Formvar replicator is normally mounted on rack No. 2 with the arm extending through an aluminum plate in the second right cabin window as shown in Figures 2.2 and 2.3. A positive seal is provided around the arm.

2.8 Time Lapse Camera

A forward looking time lapse camera is mounted as shown in Figure 2.21 on rack number one so that it looks between the pilot and copilot. The camera body is a standard Perkin Elmer Model J107, a 16 mm type often used to produce a film record of aerial combat. The Model LB26A 16 mm film magazine has been modified by Epsilon Laboratories of Bedford, MA to project the time of day digits on each frame of film. A variety of lenses are available for the camera.

The magazine holds a standard 100 ft reel of 16 mm double sprocket film. The magazine can easily be changed in flight. The camera mechanism is electrically operated and provides the power for moving the film in the magazine.

The Model E200T-DS-3 time lapse system consists of a multiplexer/transmitter unit (E210TT) and up to three receiver/display units (E210RD). Only one is used in the HAWADS. Parallel input time code data is converted to serial form by the multiplexer/transmitter unit and sent to the receivers. At the receiver, a locally generated readout command pulse causes the receiver to convert the time code input signal to a visible display in hours, minutes and seconds.

This display is imaged onto the back (non emulsion) side of the film through a slot cut into the pressure plate by means of a folded optics system of three plane mirrors and a relay lense. The relay lense and two

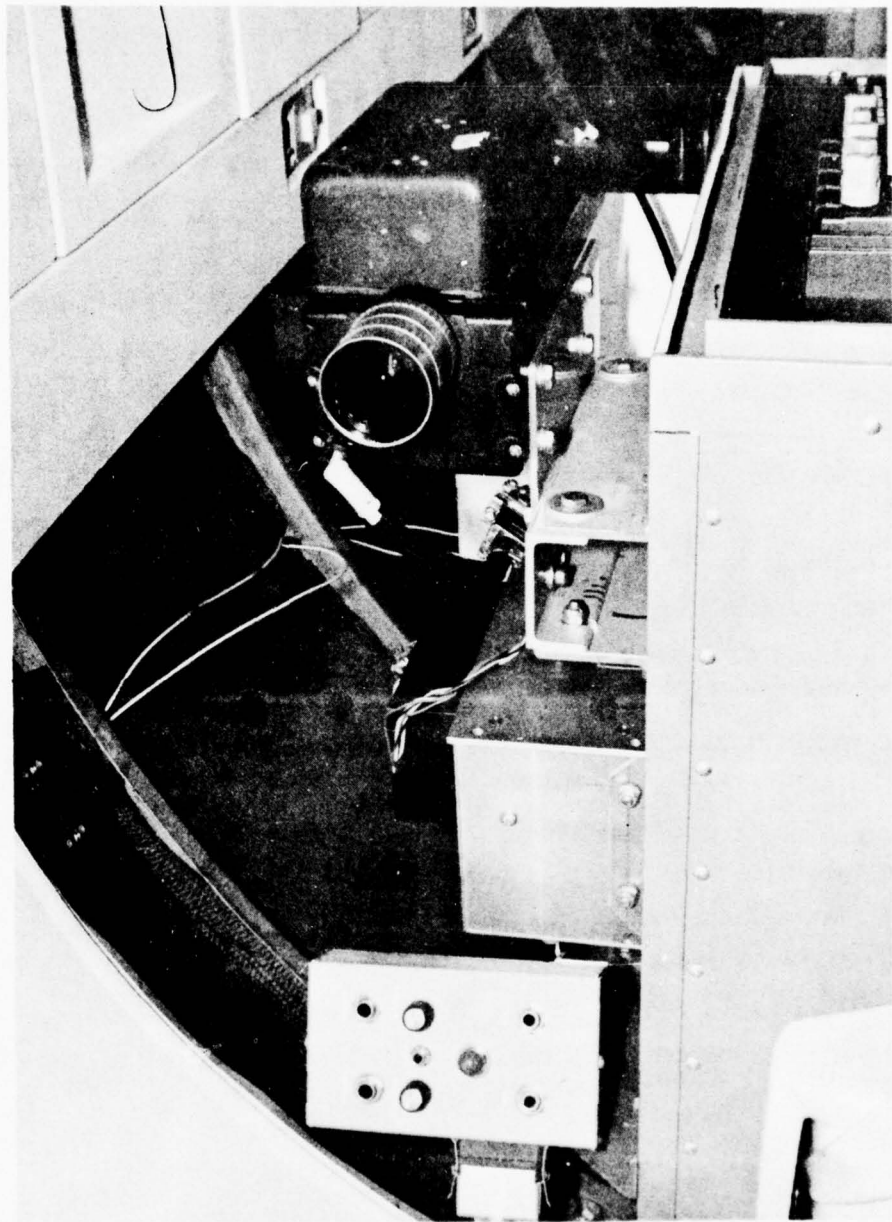

Figure 2.21 Forward-looking time lapse camera and copilot audio box.

of the folding mirrors are contained in the receiver unit which is attached to the camera magazine cover plate. The third mirror is located within the magazine and is mounted on a special fixture mounted on the rear of the pressure plate.

The transmitter unit accepts time code from the Stancil-Hoffman time code generator and produces a synchronous serial output. Six numeric characters are transmitted in serial BCD at 400 complete readouts per second. Seconds are transmitted first and tens of hours last. Three current-limited power amplifiers are used as a buffer so that as many as three parallel receivers can be used in each system.

The receiver circuitry converts the serial data to a sequential parallel format so that as each character is received it will be applied to the seven segment enable lines of the 6 digit display module. In the absence of a readout command, each receiver will be in a quiescent state in which only the BCD to 7 segment enable lines are active. Under this condition the 7 segment inputs (anodes) of the display will be supplied with power but the character select inputs (cathode returns) are not active. Consequently no visible output is produced. When the camera shutter command input is activated, circuitry in the receiver causes the receiver to display the next complete time code received. The anode inputs of the display are powered. The receiver generates a set of character select inputs which are used to select the appropriate cathode return elements of the 6 digit display array. As a result of the character select inputs, as each BCD time is received and decoded, the associated decimal digit of the display is illuminated.

2.9 Total Water Content Instrument (TWCI)

The TWCI has been built by Meteorology Research Inc. under contracts with the Air Force Geophysics Laboratory. One version of the TWCI has been installed in N36TA.

It is designed to measure total water content in both liquid and solid hydrometeors. It uses a butyl carbitol fluid to wash a collection plate which is mounted in the nose cap of the aircraft and exposed to the air-flow, so that the particles are collected in the fluid. They are then melted by the warm fluid and carried to a sensing chamber. The sensor uses a capacitor in a tuned circuit with the fluid as the dielectric. Water in the fluid changes the capacitance and the output frequency of the tuned circuit. Electronic circuits detect the shift by comparing with an identical cell with pure butyl carbitol as the dielectric. The output of this system is calibrated in terms of water content.

The TWCI has an elaborate system of heaters and fluid controls to manage the conditions of flow through the sensor. The fluid tanks and associated control valves and pumps are located in the back of the cabin. The control panel and electronics are mounted in the bottom of rack 5. The output signals are fed to the BMS and are thus made available to the computer.

The TWCI is in the final stages of testing and evaluation in preparation for operational use. Very limited documentation on it is available. This document will be revised to include a more detailed description of the TWCI when more information is available.

2.10 Snow Stick

The snow stick shown in Figure 2.14, is a streamlined rod attached to an aluminum plate in the second left cabin window. An electric deicer boot is provided on the leading edge for deicing. An observation stage with a one square centimeter surface is provided at the outer end of the leading edge. Electrical deicing is provided but is insufficient to melt snow, so the surface can not be used in snow because of rapid ice buildup. The deicer boot provides a secondary observation surface which can usually be used in snow because the slick contoured surface sheds ice more easily. However, residence time of snow particles is extremely short except on the leading edge where an ice buildup occurs.

The snow stick is visible to the flight meteorologist and is used as a means of stopping ice particles long enough to judge their relative size and frequency. Crystal habit can be observed to some degree but the particles are usually shattered on impact and tend to pile up in snow. A special light is installed to illuminate the snow stick at night, however, a flashlight through the window gives better results.

An additional observation aid for the meteorologist is provided by special black paint on the inboard side of the left wingtip. This black background enables the meteorologist to judge the relative size and intensity of frozen hydrometeors.

2.11 AIP/Transmuter

This is a rack-mounted chassis custom-built by MRI to contain auxiliary interface equipment (hence AIP, Auxiliary Interface Panel). It is installed below the computer in rack No. 5 as shown above in Figure 2.4.

At present, the AIP contains only:

- the +15 VDC power supply for the Calcomp plotter
- a junction-box (for power and data cables)
- the digital display and selector switch for the 1D probe end element voltages.

2.12 Project Communication System

The project communication system provides means of communication between the meteorological observer, the equipment operator, the flight crew, the on-board audio recording equipment, and the air-to-ground radios and Flite Fone. The system block diagram is shown in Appendix A.

The technician and meteorologist normally wear headsets, with boom microphones attached, which plug into the audio junction box on the left side of the cabin between the crew seats. The intercom is usually monitored on the headphones but an off-phones-speaker selector switch is available at the audio switch panel, shown in Figure 2.20.

A press-to-talk switch attached to this headset keys the VHF or UHF transmitter. The project VHF or UHF radio receiver audio is selected via another off-phone-speaker toggle switch. Only one radio can be used at a time; recabling is required to use the other.

The aircraft flight crew can also monitor the intercom net or the project VHF/UHF radio communication by plugging their headset into an audio junction box installed behind the copilot's seat (See Figure 2.21). The flight crew can talk on intercom but do not have the capability of transmitting over the project VHF or UHF radio.

Both the intercom audio and the project VHF or UHF radio audio are also recorded on the Stancil-Hoffman audio tape recorder shown in Figure 2.22. The following channel assignments are made for the four audio tracks:

<u>Track</u>	<u>Assignment</u>
1	Intercom
2	Project VHF or UHF
3	Cockpit communications
4	Time code.

The cockpit communications are recorded only if the crew uses headsets. The recorder runs continuously during all missions.

The Wulfsberg WH18 Flite Fone is an air-to-ground radio-telephone and is independent of the project communication system except for using the technician's audio box as a junction box and an FT25 audio amplifier. The Flite Fone has its own handset.

2.13 Power Distribution

The HAWADS instrumentation equipment requires 28 VDC, 115 VAC-400 Hz, 115 VAC-60 Hz, and +15 VDC power. Detailed system cabling, schematic, and block diagrams for instrumentation power and data are included in Appendix A.



Figure 2.22 Instrument rack No. 1 showing the UHF radio, J-W LWC indicator and the Stancil-Hoffman system.

2.13.1 DC Power. Power from both aircraft DC generators (or batteries) and both 400 Hz inverters is sent to the master power distribution panel which is located in the top of rack No. 5, shown in Figure 2.23. The aircraft flight crew has primary control over power available to the instrumentation by virtue of toggle switches installed in the pilot's instrument panel and the copilot's circuit-breaker panel. The master power panel distributes left and right 28 VDC and left and right 115 VAC-400 Hz to the instrumentation system and to the three Topaz 115 VAC-60 Hz inverters. Individual power circuits are selectable by toggle switches and are protected by appropriate fuses or circuit breakers.

2.13.2 Topaz 60 Hz Inverters Model 1000GW-28-60-115. Three Topaz inverters are installed to provide up to 27 amps (1000 VA capacity each) of 115 VAC-60 Hz sinusoidal single-phase power to the instrumentation system. The units are solid state and are short-circuit and overload protected. At a nominal output power loading of 6 amps, the inverter will draw 33 amps at 28 VDC input.

2.13.3 Low-voltage Power Supplies. A commercial +15 VDC supply is installed in the AIP chassis to provide level matching to the plotter interface lines.

2.13.4 Deicing. Electrical deicing is provided for all the externally mounted sensors. It is particularly critical for the probes mounted on the fuselage because they are directly upstream from the engines. Any ice building up on the probes is likely to be ingested by the engines and may result in substantial damage or even failure of the engine. Any damage at all is likely to be quite expensive to repair.

The leading probe surfaces have 28V propeller deicing boots. They do not work as well in this application because centrifugal force is not available to slide the ice off as it is loosened by the heated boots, as it is on propellers. In this case, the boots must provide enough heat to melt the ice. The heating circuits have been modified so the heaters operate in parallel to provide maximum heat.

Some leading surfaces are deiced by electric heating elements inside the surface. The observation stage on the snow stick is one such surface. These surfaces must be monitored carefully in flight through icing conditions to detect ice buildup, which requires that the aircraft leave the icing level.

All power for deicing comes from the left aircraft generator via the master power distribution panel.

2.13.5 Aircraft Electrical Power. The aircraft is equipped with two DC generators, one per engine. Maximum power output for each is 420 amps at 28 VDC. Ammeters are provided for monitoring each unit's output. They are caution-lined at 325 amps and red-lined at 400 amps.

Two static inverters provide 115 VAC 400 Hz power. Each is rated at 1000 VA. They are about 75% efficient.

Maximum power available may be considered as

$$P_{\max} = 400A \times 28V \times 2 = 22400 \text{ VA.}$$

Peak aircraft power load levels are experienced during takeoffs and landings due to intermittent loads from the landing gear, gear doors, landing lights, flaps, etc. Very little electrical load is required for airframe deicing, since most deicing uses bleed air and alcohol. The aircraft manufacturer states the maximum aircraft requirements are 375 amps. This may be reduced somewhat with the radar removed; it uses 6 amps of 28 VDC and 60 VA of 400 Hz AC, or an equivalent of 8.9 amps of 28 VDC. Aircraft normal peak power is therefore 375 less 8.9 = 366.1 amps of 28 VDC. One generator can carry the aircraft load in the event of a generator loss but non-essential loads should be dumped.

Since the peak HAWADS power-loading occurs at altitude and in icing conditions, the aircraft takeoff and landing loads will not normally coincide. In this case, the aircraft power requirements (in normal flight using deicing systems) are about 260 amps at 28 VDC. Then, given a generator loss, only 25% of this load need be shut down to stay within safe limits. This sets an emergency condition power limit of 195 amps at 28 VDC.

2.13.6 HAWADS Power Requirements. Several instruments must have deicing on at all times in flight. A conservative estimate of this load is given in Table 2.3 and totals 117.5 amps with TWCI.

The data acquisition portion of the sensor package requires 184.25 amps at 28 VDC and 610 VA of 400 Hz 115 VAC for its operation. The various sensor package demands have been divided into four groups (2 AC, 2 DC) in an effort to equalize individual generator and inverter loading. The following is a summary of the power requirements.

Aircraft requirements	366 amps
Sensor Package - DC	302 amps
Sensor Package - AC	29 amps
<hr/>	
TOTAL	697 amps

With all aircraft and sensor package systems operating, the generators work at 87% of red line. During normal flight conditions aircraft requirements are reduced to 260 amps and generator loading drops to 74% of red line.

At the first indication of a generator problem the data acquisition section of the sensor package should be turned off manually. If generator failure occurs with no warning, the data acquisition portion of the sensor package is automatically dumped by the power tap circuitry.

The following is the loading level on the remaining generator.

Aircraft requirements	260 amps
Sensor package - essential deice	117.5 amps
<hr/>	
TOTAL	377.5 amps

It would be operating at approximately 94% of red line output. However, when aircraft nonessential items are dropped, the loading is reduced to:

Aircraft requirements (essential only)	195 amps
HAWADS (essential only)	117.5 amps
<hr/>	
TOTAL ESSENTIAL	312.5 amps

TABLE 2.3 POWER LOADING CHART

INSTRUMENT	TOPAZ NO. USED	RIGHT 28 VDC	60 Hz AC	400 Hz AC	LEFT 28 VDC
BMS	1	8.0	1.0		
1DC			0.5		2.5
1DP	1		1.0		3.0
Kennedy recorder	1		1.3		
DAS	2		0.7		
2DC				1.5 (Rt)	6.0
2DP				1.5 (Rt)	6.0
Pertec formatter, recorder	2		1.5		
PID	2		0.6		
Stancil-Hoffman	1		1.3		
J-W LWC				0.8 (both)	15.0
Formvar replicator		25.0			20.0
Dewpoint	1		.8		
Temperature		0.25			10.0
Δ Pressure transducer		0.25			
Pressure transducer		0.25			
Computer	3		5.5		
Plotter	2		1.5		
TI Printer	2		2.0		
TWCI		20.0			40.0
Time lapse camera				0.5 (Lt)	15.0
AIP		0.5			
Beacon		1.0			
Radio - UHF/VHF		10.0			
Inverter 1		33.0			
Inverter 2		34.5			
Inverter 3					31.0
Snow Stick		2.5			5.0
ASSP				1.0	10.0
Flite-Fone		3.0			
Paper tape reader			2.0		
Power supply +15 VDC	3		1.0		
		138.25	20.7	5.3	163.5

The remaining generator is reduced to 78% of red line.

In summary, the aircraft generating system is adequate to provide HAWADS power requirements safely. A review of the generator demand levels indicate that even in the event of an emergency (engine/generator loss), sufficient power generation exists to provide all essential aircraft and HAWADS systems.

2.13.7 Protective Devices. Due to the high level of HAWADS demands, the various sensor components were divided into two equipment groups that would present approximately equal power demands on the left and right generator busses. This is to prevent possible overloading of either generator. Also, since the aircraft is equipped with a load equalizing circuit, provision is made to prevent the entire HAWADS demand from being transferred to one generator in the event that one generator fails. Both automatic and manual protective devices are included in the main power tap lines. Automatic and manual drop provisions are included to remove the HAWADS from aircraft power in the event of any emergency.

Wire sizes, breaker types, fuses and switches, buss-bars and terminal strips are in accordance with FAA AC 43.13-1A. The power tap system is provided with interlock switches located at the pilot's instrument panel. The pilot, therefore, maintains complete control of the aircraft and sensor electrical systems.

The following is a brief explanation of the various protection devices included in the installation.

ACB1 and ACB2 are precision heavy load automatic reset circuit breakers which are installed near the left and right generator busses to which they are attached, thereby providing protection of all sensor package cabling in the event of a grounded line, etc. Power relays, PRL1 and PRL2, are adjacent to ACB1 and ACB2 and are controlled manually by the pilot, and automatically sense relays CRL 1, 2 and 3. In the event that a generator fails, CRL2

immediately opens PRL2, removing that load. Sensor device will remain on unless manually dropped by the pilot. CRL1 and CRL3 are arranged in a self-latch configuration so that once they have been de-energized they will not activate unless manually reset. This method prevents a load from reappearing on-line once a fault is detected. All circuit breakers in the HAWADS distribution panel are of the "trip-free" type and fuses are of the AGC fast-blow series, thereby protecting all lines diverging from that panel. A small toggle switch is installed on the right side of rack #5 which overrides the automatic disconnect feature of the power tap system. When the switch is in the override position, the instrumentation can be powered by the aircraft batteries or a ground-power cart. A drawing of the power tap system is included in Appendix A.

2.13.8 Cable Lists. The complete instrumentation system cable list is attached to this manual as Appendix A.

2.14 Ground Support Equipment

Data collected in-flight can be partially reduced for post-mission "quick look" analysis using a Versatec printer/plotter to replay the 2D data and a Stancil-Hoffman audio tape transcriber to recover observations made by the flight crew during the mission.

2.14.1 Printer Plotter. A PMS printer/plotter interface is used to provide the necessary control and storage electronics for interfacing the Versatec printer/plotter to the Pertec magnetic tape formatter. The playback system provides a convenient means of generating hard copy directly from data recorded during the mission on magnetic tape from the PMS 2D data acquisition system. The system will automatically print all slow data recorded and plot all image data recorded for as long as desired. It is possible to select either images only or slow data only to be copied if both types of data are not necessary for a particular data run.

A four digit decimal display is provided to allow reading a tape and displaying the time recorded without copying either type of data on the printer/plotter. In this way a specific portion of data can be located and copied without having to copy all the data preceding it on the tape. An error lamp is also included to indicate parity failures as they occur in reading the tape.

The unit mounts in a desk top cabinet along with the Pertec tape transport and formatter. This cabinet is about the same size as the Versatec printer/plotter which can be rolled alongside for operation making a compact system for use in the field. Figure 2.23 shows an example of the 2D data printout. This printout is a part of this mission data package and is also used to monitor the 2D data system for faults. Portions of the 2D record can be expanded for more detailed analysis. The 2D tape is later shipped to the AFGL CDC 6600 computer facility for complete data reduction and analysis.

Table 2.4 PRINTER/PLOTTER INTERFACE SPECIFICATIONS

Data input	8 bit parallel input with strobe for each byte and end of record signal from tape formatter
Data output	8 bit parallel output with strobe for each byte and end of line signal to printer/plotter
Image storage capacity	4096 bytes from tape (1024 Image Slices)
Decimal display	4 digit readout of the last time read from tape for seeking specific data segments for hard copy output
Power	115V, 60 Hz, less than 1/2 amp
Dimensions	19" wide x 10" deep x 5 3/4" high
Weight	Less than 15 pounds

2.14.2 Audio-Tape Transcriber. The audio tape transcriber consists of a Stancil-Hoffman CRM 7/19/28 recorder/reproducer tape transport and an S-H TR2400 time reader which is designed to monitor the time-code track on the audio tape and display the time-of-day of the original recording (at any tape speed or in either direction).

The meteorological observers normally transcribe their own audio tapes immediately after each flight to annotate mission events.

2.14.3 Ground Power Unit. A ground power unit capable of generating 300 amps at 28 VDC is required to provide primary power to the aircraft for ground testing. The GPU can be either gasoline or electrically powered.

3.0 CALIBRATION PROCEDURES

The HAWADS includes five particle probes and five meteorological sensors, all of which require periodic calibration checks to ensure data quality. Each system has its own calibration procedure and associated equipment. The TWCI calibration procedures are not included at this time.

Since the five flight condition sensor outputs are recorded on both the BMS and the DAS-2D, the calibration check must include both recording systems. It is the chief technician's responsibility to assure the calibration on a timely basis and to keep the appropriate records on file.

3.1 Pressure System

3.1.1 Equipment. The aircraft must be taken to an authorized aircraft repair shop for the pressure transducer calibration. Airspeed or ΔP can be calibrated at the same time.

The altimeter/airspeed calibration test set consists of:

1. A calibrated altimeter
2. A calibrated airspeed indicator
3. A vacuum pump
4. A pressure source
5. An assortment of airtight hoses and connectors
6. Regulating valves.

3.1.2 Calibration Procedure (Minimum: once every 6 months). Attach the test set to the aircraft pitot tube and static pressure port. Complete a leak test to ensure an airtight system and a static time test on the copilot/meteorological altimeter system to ensure that internal leaks fall within FAA limits. Then proceed as follows:

1. Power up HAWADS including the computer except for PMS 2D sensors, LWC, and dewpoint, using an APU.
2. Adjust the calibrated altimeter and both cockpit altimeters to 29.92 in Hg.

3. Start the vacuum pump.
4. BMS: dial in auxiliary data, channel 1. (pressure)
5. DAS: dial in channel 040. (pressure)
6. Adjust vacuum valve to raise the altimeter to the desired altitude. CAUTION: As altitude (vacuum) increases, pressure must be decreased on the pitot system to keep the Airspeed indicator within its allowable range to avoid damage to the instrument. Also ensure that the rate of ascent or descent does not peg the Vertical-Speed Indicator instrument.

7. After the altitude reading is steady for 5 seconds,
 - A. Start sample on TI
 - B. Record:

TIME	BMS	DAS	CAL. ALT.	COPILOT ALT
hr/	mv	mv	ft	ft

C. End sample on TI, wait for it to begin printing.

8. Repeat steps 6 and 7 from 0 to 30 kft in 2 kft steps, then from 31 to 50 kft in 1 kft steps, then from 48 to 2 kft in 2 kft steps
9. Shut system down and detach special equipment or do airspeed test.
10. Plot values of calibrated altitude against BMS, DAS, copilot, and TI printed altitudes, or millivolts, respectively. Verify that they fit the calibration curve in use. If not, derive a new curve or send altimeter unit to Validyne for calibration.

The present calibration curve is shown in Figure 3.1.

3.2 Differential Pressure System

3.2.1 Equipment. The same altimeter/airspeed calibration test set is used to calibrate airspeed as described above. Observe the same cautions to avoid damage to the flight instruments.

3.2.2 Calibration Procedure. (minimum: once every 6 months). Attach the test set and follow procedures as described in the last section to step 2. Then proceed as follows:

3. Start vacuum pump and adjust values to a constant altitude indication of 20 kft. Keep this reading steady for all airspeed calibration readings.
4. BMS: dial in auxiliary channel 2. (delta pressure)

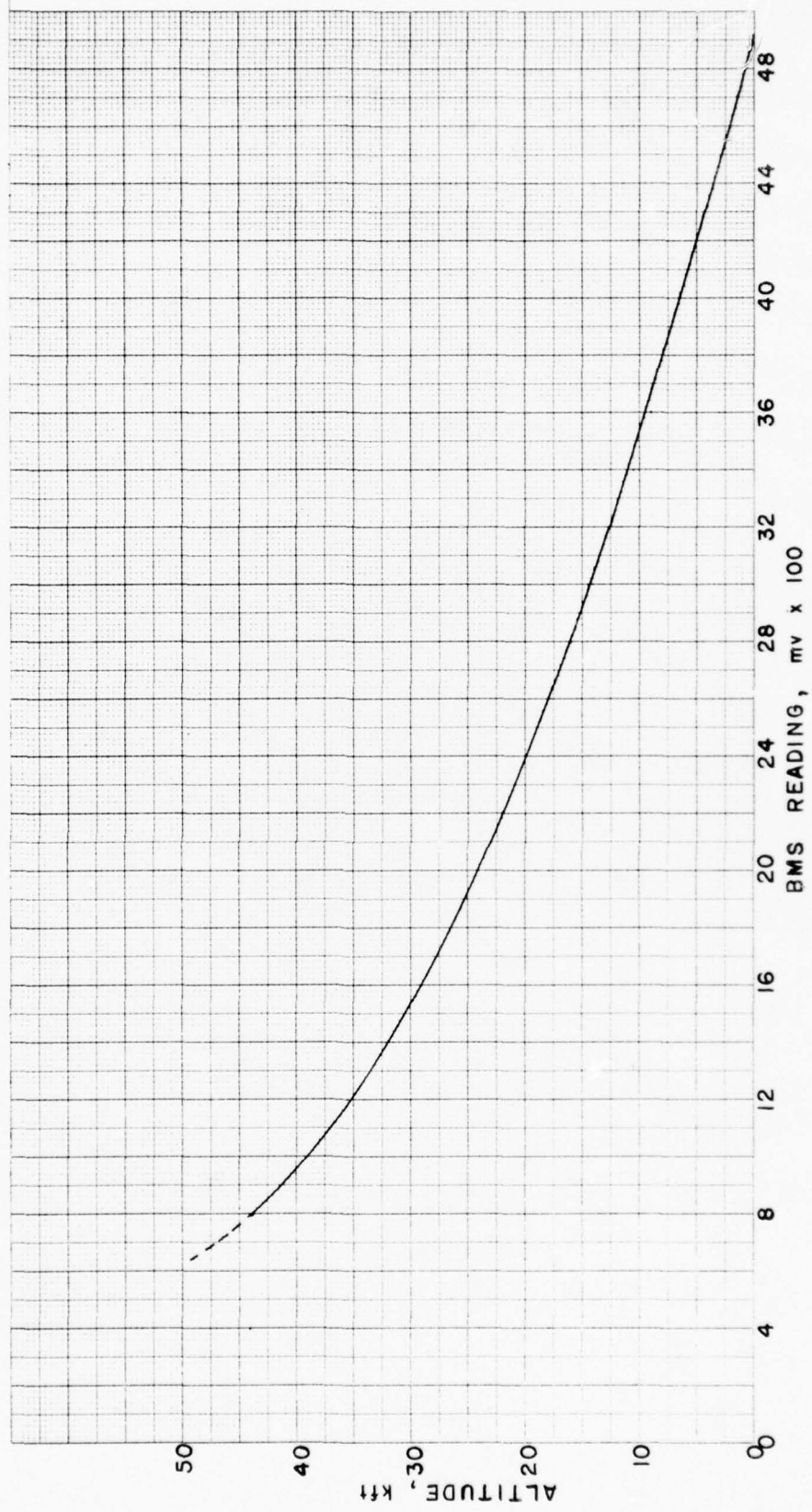

Figure 3.1 The calibration curve of the altitude (pressure) transducer for the BMS.

5. DAS: dial in channel 050. (delta pressure)
6. Adjust valves to specific calibrated airspeed indications at an altitude of 20 kft. Keep the readings steady for 5 seconds.
7. When steady:
 - A. Start sample on TI
 - B. Record:

TIME	BMS	DAS	CAL. IAS	COPILOT IAS
hr/min/sec	mv	mv	kt	kt

- C. End sample on TI, wait for TI to begin printing.
8. Repeat steps 6 and 7 from 0 to 300 knots in 20 kt. steps, then from 300 to 0 knots in 50 kt. steps.
9. Shut system down and detach special equipment.
10. Plot the values of calibrated airspeed against BMS, DAS, copilot, and TI printed airspeeds or millivolts, respectively. Verify they fit calibration curve in use. If not, derive a new equation or send airspeed transducer to Validyne for calibration.

The present calibration curve is shown in Figure 3.2.

3.3 Temperature Sensor

3.3.1 Equipment. An accurate decade resistance box with suitable leads is required. The range of the decade box must be from 350.00 to 600.00 ohms. A bag of ice is used late in the calibration procedure as a final ice-bath check.

3.3.2 Calibration Procedure (Once every month). The Rosemount temperature sensor is calibrated by replacing the temperature sensor with specific and accurate resistance values and simultaneously reading the BMS and DAS millivolt values:

<u>Resistance</u>	<u>BMS</u>	<u>DAS</u>	<u>TI Temp.</u>	<u>Temp.</u>	<u>Output</u>
ohms	mv	mv	°C	°C	mv
359.10				-70.0	- 2
389.57				-55.0	+ 626
419.88				-40.0	+1253
450.04				-25.0	+1879
480.06				-10.0	+2506

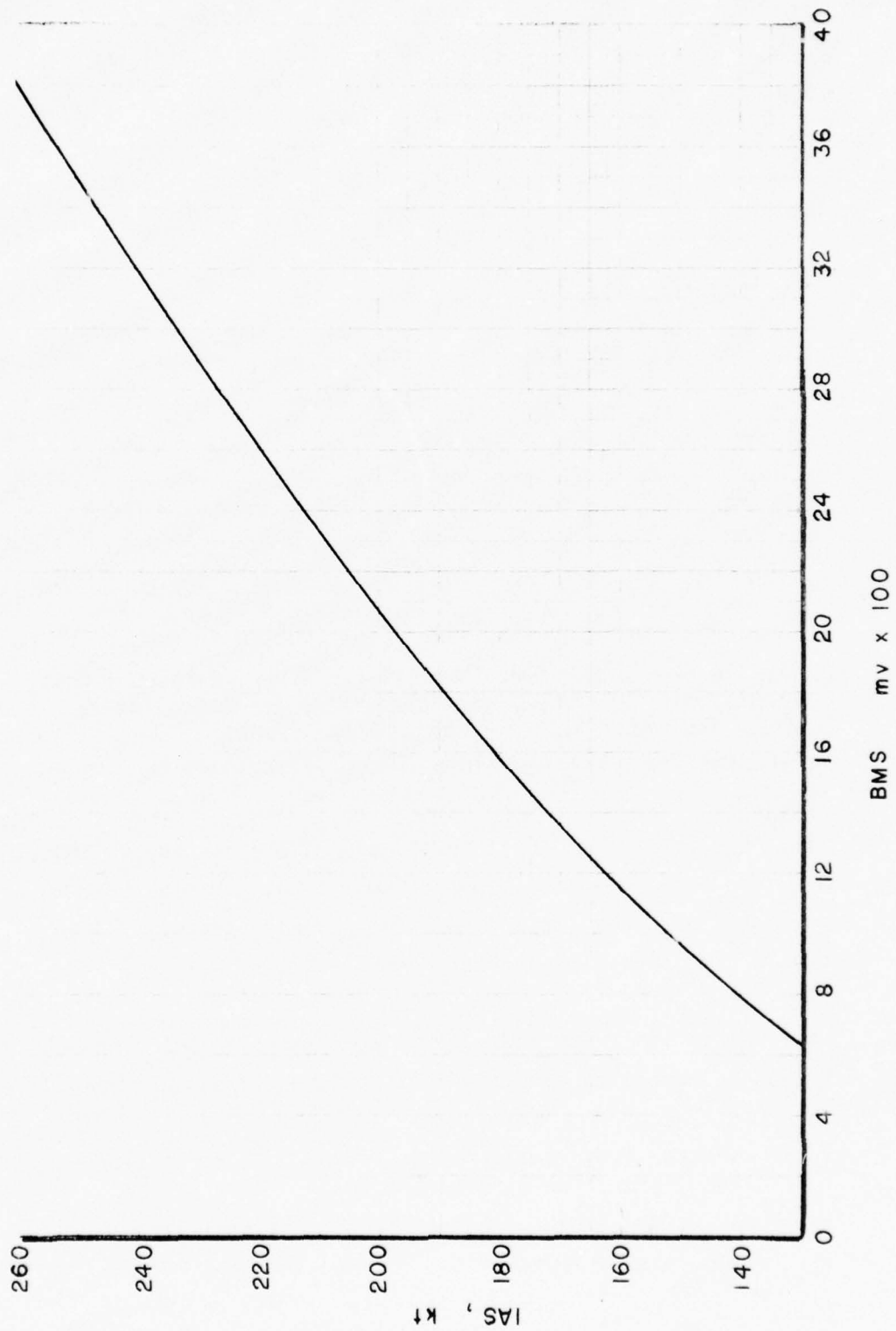

Figure 3.2 The calibration curve of the airspeed (delta pressure) transducer for the BMS.

<u>Resistance</u>	<u>BMS</u>	<u>DAS</u>	<u>TI Temp.</u>	<u>Temp.</u>	<u>Output</u>
ohms	mv	mv	°C	°C	mv
509.95				+ 5.0	+3132
539.77				+20.0	+3758
569.34				+35.0	+4383
598.84				+50.0	+5009

Proceed as follows:

1. Remove the thermistor and attach the decade resistance box to the appropriate points to substitute resistance in place of the thermistor.
2. Power up the HAWADS and computer using an APU.
3. Insert the first resistance.
4. Start sample on TI, record BMS and DAS millivolt readings, and end sample on TI. Record TI calculated temperature.
5. Insert other resistance and repeat item 4. Shut down system.
6. Verify that each input resistance results in the correct millivolt and temperature output. If not, derive a new temperature equation or send the temperature amplifier and probe to Rosemount for calibration.
7. Replace the temperature thermistor. Power up the temperature system and check for 0°C readings when thermistor is surrounded by a well mixed ice-water bath. Power down the system.

The present temperature calibration curve is shown in Figure 3.3.

3.4 Dewpoint

3.4.1 Equipment. Two calibration plugs, one marked low the other marked high are located inside the cover of the electronics box. A sling or fan aspirated psychrometer and relative humidity-dewpoint slide rule are used as a final dewpoint check.

3.4.2 Calibration Procedure (once each month). The dewpoint system is calibrated by replacing the sensor with the calibration plugs. Proceed as follows.

1. Remove the connector from the sensor head and attach the connector to the calibration plug marked low.
2. Power up the HAWADS except for the 2D system.
3. The BMS should indicate 0.500 v and the TI printout should be -40°C Dewpoint.
4. If it does not indicate properly adjust R11 in the electronics box of the dewpoint for the proper indication.

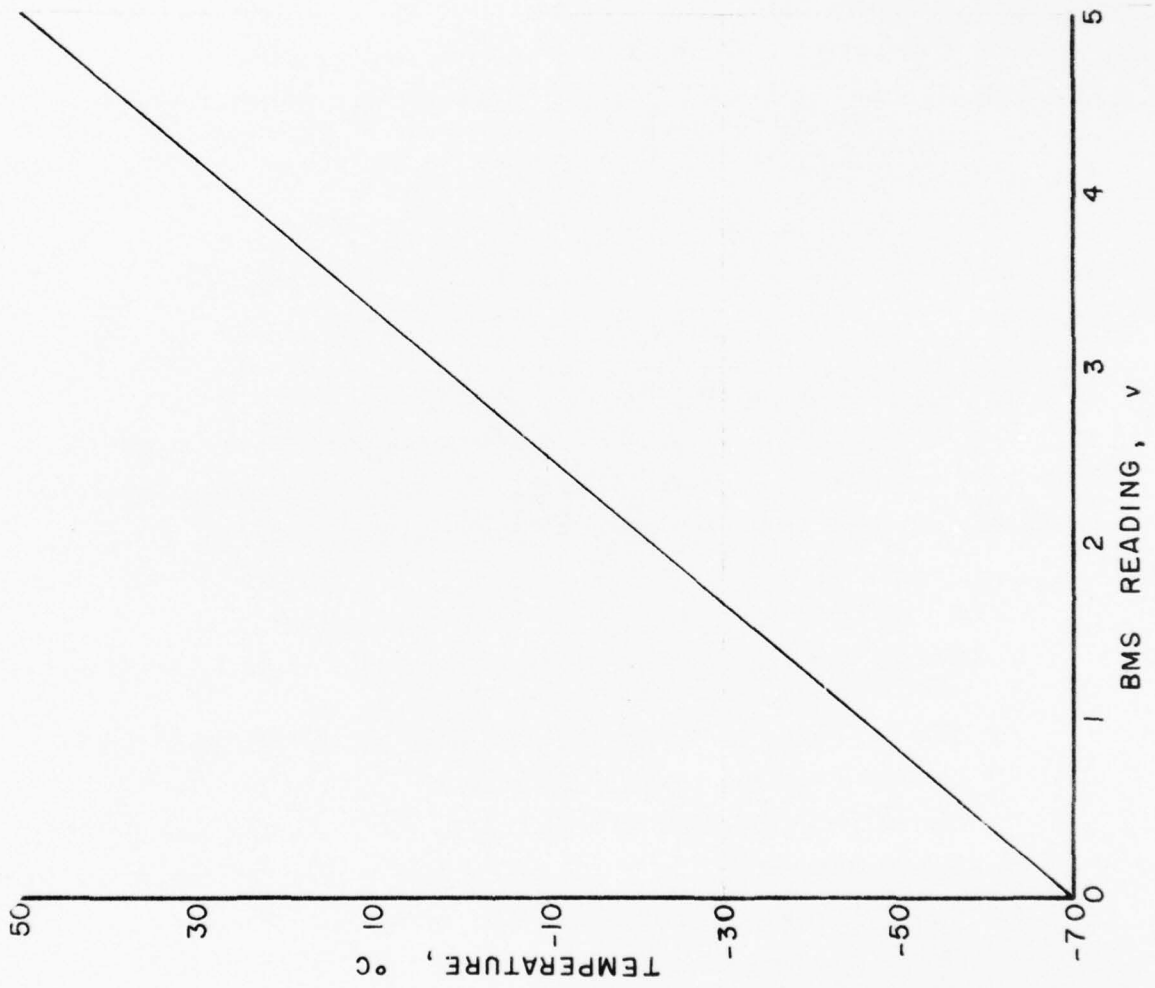

Figure 3.3 The calibration curve of the temperature system for the BMS.

5. Remove the connector from the calibration plug marked low.
6. Attach the connector to the calibration plug marked high.
7. The BMS should indicate 4.500 v and the TI printout should be +40°C dewpoint.
8. If it does not indicate properly adjust R15 in the electronics box of the dewpoint for the proper indication.
9. Recheck both low and high after final adjustment.
10. Install the connector back on the sensor head.
11. Perform a final check on the temperature-dewpoint systems using a sling or fan aspirated psychrometer. The calculated TI values should agree with the psychrometer derived temperature-dewpoint within $\pm 1^\circ\text{C}$.
12. Power down the HAWADS.

The current dewpoint calibration curve is shown in Figure 3.4.

3.5 Johnson Williams Liquid Water Content

3.5.1 Equipment. Calibration equipment consists of a model LWH dummy head supplied by the manufacturer. The dummy head has a toggle switch to change from zero to a high scale calibration position.

3.5.2 Calibration Procedure. (once each month)

1. Remove the liquid water content sensor and install the dummy head in its place. Power up the HAWADS.
2. Set the range switch on the readout panel to 0-1 gm/m³ scale.
3. Set the airspeed knob to 200 knots.
4. Place the dummy sensing head toggle switch to the zero position.
5. Unlock and set the zero adjust knob to a zero indication and lock it.
6. Place the dummy sensing head toggle switch to the full scale position.
7. Unlock the calibrate adjustment knob, adjust it to full scale (1g/m³) indication and lock the calibrate adjustment knob. Power down system.
8. Remove dummy sensing head, verify that the wires in sensing head are not broken or open, and install sensing head.

The current calibration curve is shown in Figure 3.5. This completes the calibration procedures for the five meteorological sensors.

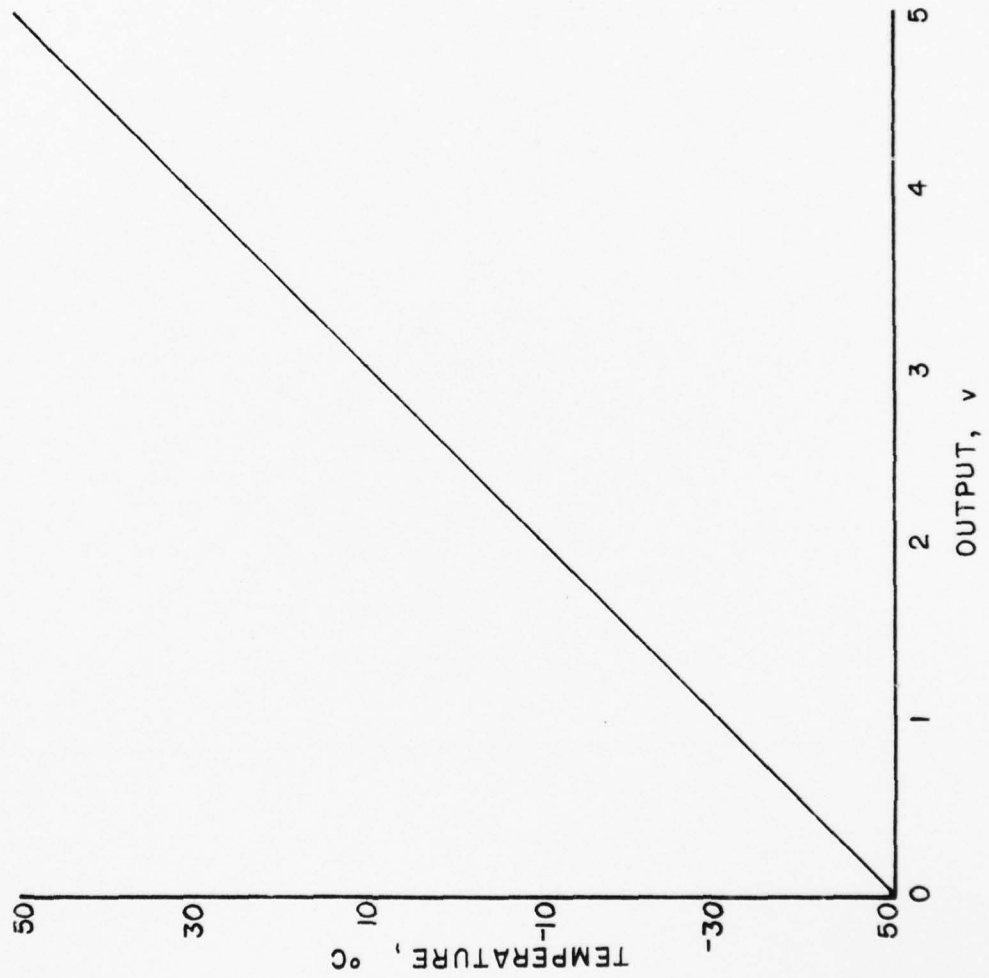

Figure 3.4 The calibration curve for the dewpoint system.

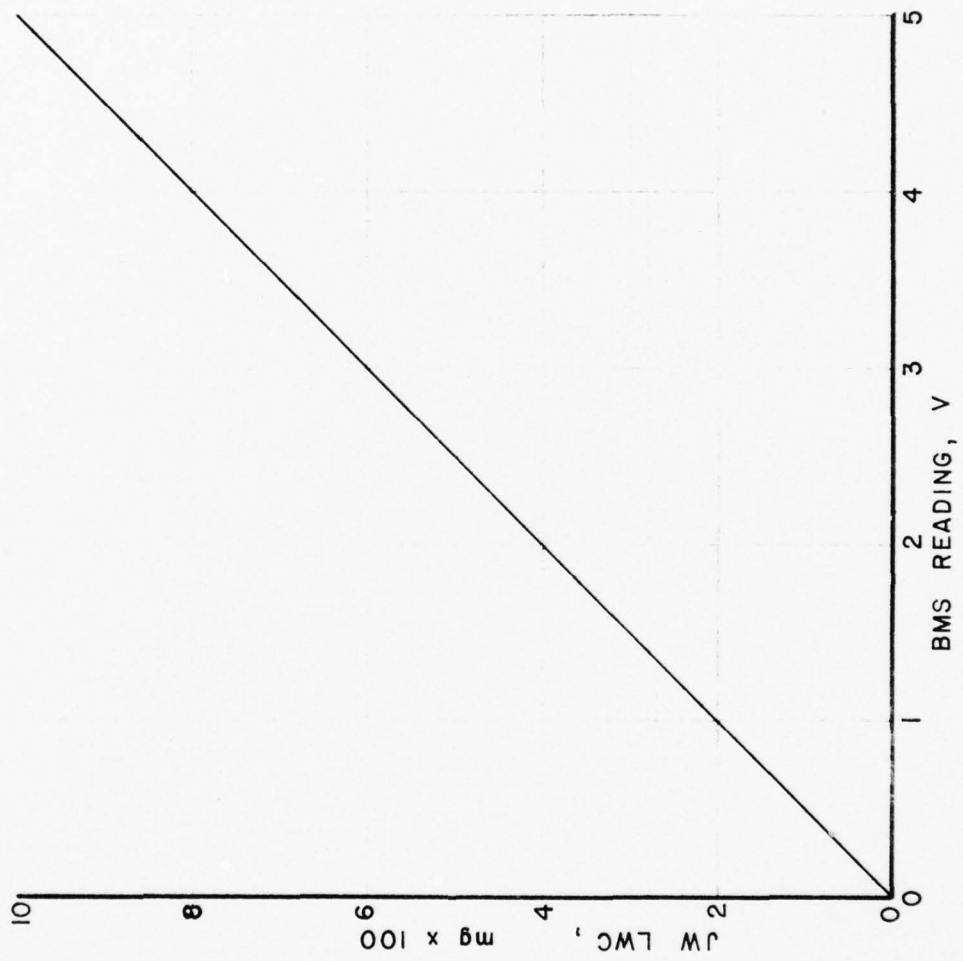

Figure 3.5 The calibration curve for the J-W LWC for the BMS.

3.6 Axial Scattering Spectrometer Probe

3.6.1 Equipment. Calibrated glass beads of about 12 and 24 micron sizes are required to simulate water droplets. Beads are available from Particle Information Services, Inc., Grants Pass, Oregon.

3.6.2 Calibration Procedures. Perform a calibration check on the ASSP probe once each month as follows:

1. Remove probe from its mounting on the side of the aircraft.
2. Connect the probe on the inside of the aircraft with it sitting in a position where glass beads can be poured through the light beam.
3. Turn on the computer and the 1D system in accordance with the checklist.
4. Allow approximately 10 minutes warm up time.
5. Run a 3 minute sample on the TI printer to check for noise.
6. If the sample shows noise on the printout, the problem should be resolved before continuing the calibration check.
7. Start a sample on the TI.
8. Pour calibrated 12 micron glass beads through the beam and catch them on the other side for reuse.
9. End the sample on the TI.
10. Check the TI printout for proper sizing and record the results on a calibration form.
11. Start a sample on the TI.
12. Pour calibrated 24 micron glass beads through the beam and catch them on the other side for reuse.
13. End the sample on the TI.
14. Check the TI printout for proper sizing and record the results on a calibration form.
15. If it checks OK reinstall it on the aircraft.
16. If it does not check OK send it to PMS for cleaning and calibration.
17. Power down system in accordance with the checklist.

3.7 1D Cloud Probe

3.7.1 Equipment. Calibrated glass beads of about 150 and 250 micron size are required. Test cables are needed to operate the probe on a bench and to operate it outside its housing while it is connected to the data system.

3.7.2 Procedure. Perform a calibration check on the 1D cloud probe. (Once each month)

1. Remove the probe from its housing.
2. Set the probe up on a bench with the bench test cable and allow 30 minutes warmup time.
3. Clean all optics.
4. Cover the laser output and the diode array with black tape.
5. Check and set, if necessary, all null voltages to -0.02 to -0.03 VDC using a calibrated digital voltmeter.
6. Remove the tape and clean the diode array.
7. Centering of the laser beam on the diode array should be checked visually and the optics adjusted, if necessary, to center the beam. Beam should not be realigned to give equal edge diode output voltages. These voltages should be recorded and if they are not of sufficiently high value - at least one volt - the cause of the low output should be investigated. It could be a defective 152 card, dirt on the optics, a poor laser, etc.

NOTE: "Calibration", or adjustment of the magnification of the imaging optics, should be done with as large a size bead as feasible as there is some imprecision caused by the position of a bead with respect to the diodes, i.e., whether the edge of the shadow occludes a diode by over 50% or by less, and this imprecision of \pm one diode is a smaller percentage of a large shadow than a small shadow. Once the proper magnification is set and the optics locked by set screws, the "calibration" should not change barring some drastic change to the imaging optics. What is more likely to happen is a failure of an IC in the summing circuits and the proper functioning of the 9304 ICs on the PMS 170 and 172 cards should be verified occasionally to assure proper sizing of drops.

8. Take the probe to the aircraft and hook up with the calibration cable with the probe inside the aircraft. Attach one end of the cable to the probe and the other end to the connector in the housing that the probe was removed from.
9. Turn on the computer and the 1D system in accordance with the checklist.
10. Allow approximately 10 minutes warmup time.
11. Run a 3 minute sample on the TI printer to check for noise.
12. If the sample shows noise on the printout, the problem should be corrected before completing the calibration check.
13. Start a sample on the TI.
14. Pour the 100 micron glass beads through the beam and catch them on the other side for reuse.
15. End the sample on the TI.
16. Check the TI printout for proper sizing and record results on a calibration form.

17. Start a sample on the TI.
18. Pour the 200 micron glass beads through the beam and catch them on the other side for reuse.
19. End the sample on the TI.
20. Check the TI printout for proper sizing and record the results on a calibration form.
21. If it checks OK, reinstall it in its housing on the aircraft.
22. If sizing is not correct, check ICs as noted, check proper operation of photodetector Modules - cards PMS 152 and magnification of optics. Probe should be sent to PMS only if local maintenance is incapable of repairing and adjusting it. Repeat the calibration check starting with step 13.
23. Power down the system using the checklist.

The current calibration data are shown in Figure 3.6.

3.8 1D Precipitation Probe

The procedure for this probe is the same as for the 1D cloud probe except that 1,000 and 2,000 micron beads are used in steps 14 and 18. The words objective lense should be substituted for zoom lense in step 22. The calibration data are shown in Figure 3.7.

3.9 2D Cloud Probe

3.9.1 Equipment. Calibrated glass beads of about 400 and 1000 micron size are required. A test cable for bench operation and a calibration cable for operation on the system while removed from the housing are required.

3.9.2 Calibration Procedure. To perform a calibration check on the 2D cloud probe. (once each month)

1. Remove the probe from its housing.
2. Set the probe up on the bench with the test cable and allow 30 minutes warmup time.
3. Clean all optics.
4. Cover the laser output and the diode array with black tape.
5. Check and set, if necessary, all null voltages to -0.02 to -0.03 VDC using a calibrated digital voltmeter.
6. Remove the tape and clean the diode array.
7. Check reference voltages for good optical alignment and adjust if necessary. Record all reference voltages on a calibration form.

TITLE		PMS CALIBRATION FOR		1D CLOUD		PROBE BY PMS Hope		DATE 770726	
DIODE	COMMENTS	TEST NUMBER							
		Ref Voltage	1	2	3	4	5		
1		1.9							
2		1.7							
3		1.6	0						
4		1.5	50						
5		1.5	112						
6		1.8	22						
7		1.5	2						
8		1.7	1						
9		2.2	0	0					
10		2.6		2					
11		2.7		47					
12		2.5		46					
13		2.4		1					
14		2.4		0					
15		2.4							
16		2.3							
17		2.1							
18		2.0							
19		2.8							
20		2.6							
21		2.3							
22		2.0							
23		1.6							
24		1.8							
25									
26									
27									
28	Figure 3.6 An example of calibration data from PMS for the								
29	1DC probe.								
30									
31									
32									
33	Size of particles used, microns		95± 15	230± 20					
34	EFFECTIVE DIODE SPACING		18.2	20.0					
35	Comments:	Zoom lense is just slightly off 10X setting.							
36									
37									

TITLE		PMS CALIBRATION FOR 1D PRECIP			PROBE	BY	PMS Hope	DATE	760726
DIODE	COMMENTS	Ref Voltage	TEST NUMBER						
			1	2	3	4	5		
1		0.8							
2		1.1							
3		1.7							
4		1.9							
5		1.9							
6		1.6							
7		1.5	0	0					
8		1.7	6	4					
9		1.7	28	20					
10		1.9	30	9					
11		2.0	8	0					
12		1.8	0						
13		1.8							
14		2.8							
15		1.6							
16		1.3							
17		1.9							
18		1.8							
19		2.0							
20		1.4							
21		1.2							
22		1.3							
23		1.1							
24		0.9							
25									
26									
27									
28									
29	Figure 3.7 An example of 1DP calibration data from PMS probe.								
30									
31									
32									
33	Size of particles used, microns		180± 150	1850± 150					
34	EFFECTIVE DIODE SPACING		194	201					
35	Comments:								
36									
37									

8. Take the probe to the aircraft and hook up with the calibration cable so that the probe is inside the aircraft. Attach one end of the cable to the probe and the other end to the connector in the housing that the probe was removed from.
9. Turn on the 2D system in accordance with the checklist.
10. Allow approximately 10 minutes warmup time.
11. Put the 2D DAS switches to TEST, MAX, RUN, ALL, and L (Cloud Probe).
12. If a field printer plotter is available, record the test on the Pertec recorder.
13. Pour 400 micron glass beads through the beam and catch them on the other side for reuse.
14. Put the 2D DAS switches to HOLD, EXPAND and A.
15. Count each particle size on the PID (or the printer plotter output, if available) counting each dot of the particle top to bottom (vertical) and multiply by 40 microns. Record the counts and sizes on a calibration form.
16. Put 2D DAS switch to B and repeat step 15.
17. Put 2D DAS switch to C and repeat step 15.
18. Put 2D DAS switch to D and repeat step 15.
19. Figure the average size and record on a calibration form.
20. Repeat steps 11 through 19 using 800 micron size glass beads.
21. Power down the system in accordance with the checklist.
22. If it checked OK reinstall the probe on the aircraft.
23. If sizing is not correct, check ICs as noted, check proper operation of Photodetector Modules - cards PMS 152 and magnification of optics. Probe should be sent to PMS only if local maintenance is incapable of repairing and adjusting it. Repeat the calibration check starting with step 13.
24. If field printer plotter is available reduce tape with expanded output. Figure the average particle size and record on a calibration form.

The current calibration data are shown in Figure 3.8.

3.10 2D Precipitation Probe

The procedure is the same as for the 2D cloud probe except that 1,600 and 3,200 micron beads are used in steps 13 and 20. The number of diodes occulted (step 15) should be multiplied by 160 rather than 40. In step 23, the objective lense should be adjusted. The current calibration data are shown in Figure 3.9.

3.11 Time Code Generator

The time code generator uses a crystal controlled time base. It has been adjusted at the factory to keep very accurate time and normally should

TITLE		PMS CALIBRATION FOR		2D Cloud	PROBE	BY PMS	Hope	DATE 760727	
DIODE	COMMENTS	Ref Voltage	TEST NUMBER						
			1	2	3	4	5		
1		1.1							
2		1.2							
3		1.4							
4		1.4	0						
5		1.4	2						
6		1.7	35						
7		1.6	4						
8		1.7	0	0					
9		1.6		7					
10		1.8		24					
11		1.9		6		0	0		
12		2.0		2		5	18		
13		2.1		0		14	19		
14		2.2				10	20		
15		1.9				3	21		
16		1.9				0	0		
17		2.0							
18		2.2							
19		2.1							
20		2.3							
21		2.1							
22		2.2							
23		2.0							
24		1.9							
25		1.8							
26		1.7							
27		1.9							
28		1.7							
29		1.6							
30		1.5							
31		1.4							
32		1.3							
33	Size of particles used, microns		230± 20	380± 20	485± 20	485± 20			
34	EFFECTIVE DIODE SPACING		38.0	37.7		36.3	35.7		
35	Comments: Zoom is set on approximately 12X.								
36									
37									

Figure 3.8 An example of 2DC calibration data from PMS.

TITLE		PMS CALIBRATION FOR 2D PRECIP		PROBE	BY PMS	Hope	DATE	760727
DIODE	COMMENTS	Ref Voltage	TEST NUMBER					
			1	2	3	4	5	
1		1.2						
2		1.4	0					
3		1.0	9		0			
4		0.9	41		17			
5		0.8	4		36			
6		1.8	0		1			
7		3.2		0	0			
8		3.1		3		0		
9		2.8		25		1		
10		2.8		19		2		
11		3.9		4		16		
12		3.2		0		16		
13		4.3				1		
14		4.1				0		
15		3.2						
16		3.8						
17		3.7						
18		2.9						
19		3.3						
20		4.5						
21		4.1						
22		3.9						
23		3.4						
24		3.1						
25		1.4						
26		2.5						
27		1.9						
28		1.7						
29		1.5						
30		1.3						
31		1.1						
32		1.0						
33	Size of particles used, microns		775± 75	1850± 150	775± 75	1850± 150		
34	EFFECTIVE DIODE SPACING		227	192	164	162		
35	Comments: Test 1 and 2 on arrival then reset to 160 micron spacing.							
36								
37								

Figure 3.9 An example of 2DP probe calibration data from PMS.

operate for long periods, much longer than the Learjet endurance, without the necessity of resetting the time.

If the unit runs consistently fast or slow it can be regulated in the same manner as a fine watch or clock. Remove the two screws holding the unit to the cabinet frame and slide it forward approximately 10 inches. Near the rear right corner of the chassis on the crystal oscillator P.C. Board assembly is located a small trimmer capacitor with the letter S in front and F to the rear of the trimmer. Rotate the trimmer with a small screwdriver to move the yellow dot toward the letter S if the clock runs fast, or towards the letter F, if it runs slow. Caution - Make only a very small adjustment, then check the clock again for a period long enough to determine the effect of the adjustment.

3.12 VCO Calibration Procedures

Both the BMS and the DAS use VCO type A-D converters in the analog input channels. The procedures described in earlier sections include the VCO's as part of the system calibrated. However, nonlinearities and inconsistencies from the BMS to the DAS can and do occur if the VCO's are not separately calibrated.

3.12.1 Equipment. This procedure requires a variable 0-10 VDC power supply with less than 1 mv of ripple and a digital voltmeter with a current calibration traceable to the National Bureau of Standards. The memo in Figure 3.10 illustrates one way to achieve a NBS traceable calibration standard for field use.

3.12.2 Calibration Procedure. (one month intervals) The VCO's in the BMS and DAS should be calibrated using the following steps:

1. Power up the BMS and DAS in accordance with the checklist. Allow at least 10 minutes warmup time.
2. Connect the variable power supply and the calibrated digital voltmeter to J1 of the junction box which is located above the TI printer.
3. Monitor the pressure channels on the BMS and DAS.
4. Set the power supply to zero volts and record the BMS, DAS and DVM readings.

aeromet

HAWADS MEMO FOR THE RECORD

SUBJECT: Calibration of Aeromet Dana DVM

BY: Harold Bowles

DATE: 12 December, 1976

The NASA Wallops Instrumentation Calibration Laboratory was kind enough to let us use their facilities to calibrate our Dana DVM on 761210.

The Lab uses a Biddle-Gray standard cell from the National Bureau of Standards and the following equipment to arrive at a voltage standard for calibrating other instruments:

1. Fluke Model 750A reference divider
2. Fluke Model 412B voltage supply
3. Fluke Model 845AB high impedance voltmeter and null detector
4. Fluke Model 5200A programm AC calibrator
5. Fluke Model 5205A precision power amplifier

This equipment is used at six month intervals to calibrate a Fluke Model 885A differential AC/DC voltmeter to an accuracy of better than 100 microvolts.

We used an HP Model 6920B meter calibrator as the voltage source. The voltage source was simultaneously read on the Fluke 885A and our Dana DVM with the following results.

<u>FLUKE 885A</u>	<u>DANA METER</u>
.99930 VDC	.999 VDC
.25000	.250
.49600	.495
.74700	.746
1.00085	1.000
1.24700	1.247
1.49950	1.499
1.75065	1.750
1.99775	1.998
2.50700	2.50
3.00200	3.00

Figure 3.10 A voltage calibration procedure for the DVM to be used in the VCO calibration.

-84-

<u>FLUKE 885A</u>	<u>DANA METER</u>
3.50550	3.50
4.00200	4.00
4.50500	4.50
5.00660	5.00
5.50247	5.50
6.00360	6.00
7.00460	7.00
8.00263	8.00
9.00655	9.00
10.00255	10.00

These results indicate that our DVM is accurate to within 1 mv. Since no adjustment has been made since it was purchased over one year ago, we must also conclude that the DVM calibration is stable.

I conclude that the Dana DVM can safely be used as the standard for calibrating the VCO's in the BMS and the DAS.

Figure 3.10 (continued)

AD-A038 469

AEROMET INC NORMAN OKLA
HAWADS EQUIPMENT DESCRIPTION AND OPERATIONAL MANUAL.(U)
JAN 77 D R BOOKER, J WINDES

F/G 4/2

UNCLASSIFIED

770112

AFGL-TR-77-0066

F19628-76-C-0103

NL

2 OF 2

AD
A038469



END
DATE
FILMED
5-77

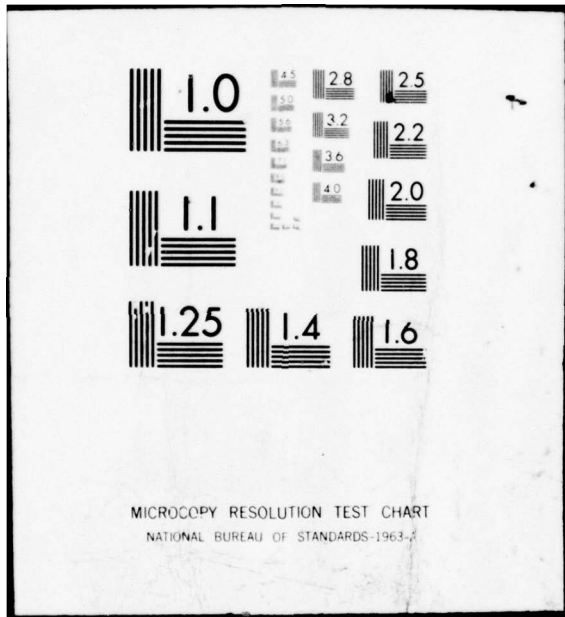

5. Repeat step 4, incrementing the reference voltage in 0.5 VDC steps to 6 VDC.
6. Repeat steps 2 through 5 for J2 (differential pressure).
7. Repeat steps 2 through 5 for J3 (temperature).
8. Repeat steps 2 through 5 for J4 (dewpoint).
9. Repeat steps 2 through 5 for J5 (LWC).
10. Apply any necessary corrections to the DVM readings to get the accurate voltages applied.
11. Plot the true voltages versus the BMS and DAS readings. Determine any offset, nonlinearity or scale factor errors.
12. Adjust the VCO's according to instructions in the Vendor manual.
13. Repeat the entire calibration procedure for any variable on which any adjustment is made.

Current BMS and DAS calibration data are shown in Figure 3.11.

3.13 Data Processing System Procedure

The computer manufacturer furnishes a diagnostic routine (QCD) which tests the computer mainframe, memory and I/O interfaces to the printer, keyboard and paper tape reader and prints the results on the TI printer. The computer plotter interface is verified by a paper tape program called CUBE. It constructs a cube on the plotter if all components are correct. The details of these and other procedures are given in the vendor manuals.

3.14 Formvar Replicator Calibration Procedure

The Formvar replicator should be run to verify mechanical operation and the film should be visually inspected for uniformity of coating.

3.15 Time-Lapse Camera Calibration Procedure

The camera system should be operated with different focus, aperture, and film speeds selected. After development, the film should be checked for proper time-encoding and exposure and to ascertain the proper lens setting for the ambient light conditions. Film framing rate is manually adjustable from very slow speed (used for objects of only general interest) to approximately 1 PPS (used during mission date-recording runs.)

3.16 AIP/Transmuter Calibration Procedure

1. The +15vdc power supply output should be measured periodically per the preventive maintenance schedule.

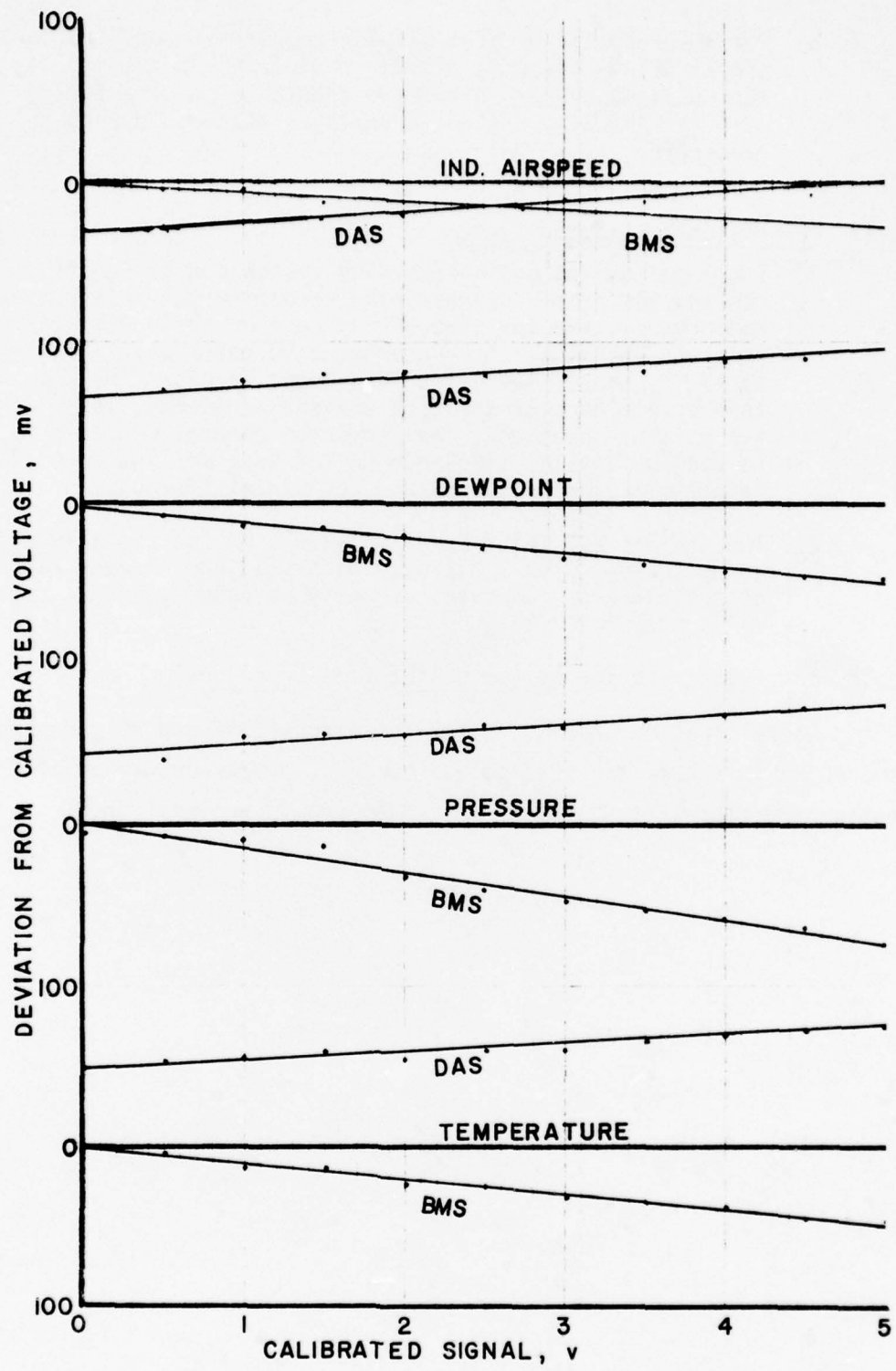

Figure 3.11 Deviation of BMS and DAS from calibrated input signal.

2. The 1D probe end-element display requires no calibration. Monitoring proper illumination of all digit segments is sufficient. However, the voltage numbers displayed should be checked for agreement with the actual end-element voltages measured during the 1D probe procedure.

3.17 Project Communication System

1. The intercom and audio recording system can be functionally checked for proper operation by recording the intercom and radio audio, and the time-of-day code on their respective tape recorder channels. The recorder's VU meter should be monitored to verify proper modulation and audio levels. The tape should then be played back and each channel monitored, in turn, via the built-in speaker. The time-code channel can also be listened to but the digital time-code on the tape will not provide an intelligible assurance of correct serial time-code.
2. The project UHF and VHF radios should be functionally checked by communicating with a nearby ground-station. Proper calibration of these radios, however, can only be done by an FAA approved radio repair facility.

3.18 Power Distribution System Calibration Procedure

No calibration procedures for the aircraft AC and DC generators or the 60 Hz inverters are available. However, proper operation of the automatic generator-fail shut-down switching should be verified.

4.0 OPERATIONAL PROCEDURES

This chapter gives recommended operation procedures for the HAWADS. The procedures are divided into functional phases and formalized into detailed check lists. Using these checklists, a knowledgeable but untrained crew member can operate the system successfully. The full checklist should be used, even by experienced crew members to avoid errors. The following sections give the procedures for preflight, flight and post flight activities.

4.1 Preflight Procedures

The preflight procedures should be completed when a scientific flight is anticipated within a few hours. At the conclusion, the system should be ready to fly on very short notice.

4.1.1 Supplies Check. The aircraft should be checked to be sure the following supplies are aboard:

1. Computer tapes - 15 ea.
2. Audio tapes - 2 ea.
3. Formvar mix ready.
4. Film, Polaroid 5 x 70 - 3 boxes.
5. Film, 16 mm - 2 rolls.
6. Film, 35 mm - 2 rolls.
7. Calcomp paper - 1 roll.
8. Calcomp pen - 1 ea.
9. TI paper - 1 roll.
10. Computer program tape for each program to be used.
11. Fuses - 1 box of each 1, 2, 3, 5, 10, 15, 20 amp.
12. Flight note forms.
13. Note pads.
14. Pencils.
15. Polaroid Camera.
16. 35 mm camera.
17. 16 mm magazine loaded and one spare.
18. Flashlights with spare batteries - 2 ea.
19. 3 headsets with boom mikes.

20. First aid kit.
21. Masking tape.
22. Scissors.

4.1.2 Power up and Systems Check Sequence. The HAWADS should be powered up to check it for proper operation using an auxiliary power unit. CAUTION! To prevent damage to aircraft batteries, always disconnect them as soon as the ground power unit is on line. The only time the batteries should be connected is to lock or unlock the aircraft and to get the ground power unit on line. Leaving the batteries connected while operating the ground power unit will cause the batteries to overcharge and boil and possibly ruin the battery completely.

The following procedures should be followed to power the HAWADS up, check the deicing circuits, and do a systems check. The deicing heaters should be checked by having one person hold his hand on the heated surface while another operates the switches.

POWER UP SEQUENCE

1. All power panel switches off.
2. All circuit breakers pulled except two marked main .
3. J - W off .
4. Dewpoint off .
5. GPU switch in full up position.
6. Check white headed circuit breakers in cockpit pulled .
7. Check four toggle switches on copilot's circuit breaker panel up on position. (Controls power to system power panel)
8. A/C battery and inverter switches off.
9. Power up ground power unit and connect to aircraft.
10. Turn both A/C battery switches on.
11. Disconnect both batteries in tail.
12. Left DC on .

DEICE SYSTEMS CHECK (two persons required)

CAUTION: Ground heater on-time should be an absolute minimum to avoid component damage.

13. 2D cloud deice on --(Check)-- off.
14. Snow stick deice on " "

15. Rosemont deice on --(Check)-- off.
16. 1D cloud " " "
17. 1D precip " " "
18. J-W " " " (400 Hz J-W power must be on)
19. ASP deice " " " (Control box deice switch must be c
20. Formvar deice " " "
21. 2D precip deice on " "

SYSTEMS CHECK

22. Both A/C inverters on (cockpit).
23. Left 400 Hz AC on.
24. TLC on.
25. ASP on.
26. Right 400 Hz on.
27. 2DC on.
28. 2DP on.
29. Left DC on.
30. Right DC on.
31. UHF on.
32. TCG on.
33. Beacon on. Check light on in hell hole.
34. Beacon off.
35. SS on.
36. AIP on.
37. SP1/temp on.
38. Topaz #1 breaker in.
39. Topaz #2 " "
40. Topaz #3 " "
41. Check all remaining switches this row down.
42. Stancil-Hoffman on, check clock on and counting.
43. Dewpoint on.
44. BMS on.
45. Kennedy on.
46. Kennedy load on.
47. When ready light comes on on Kennedy, press record switch on BMS.

48. Pertec formatter on.
49. Pertec recorder on.
50. DAS on.
51. PID scope on.
52. Press load switch on Pertec (it will take up slack).
53. Press load again, and it will advance to marker, then press on line.
54. Press record on DAS.
55. 2D DAS clock to test.
56. 2D DAS rate to max.
57. 15v supply on (2nd switch on AC strip #3).
58. Turn on 1st switch on AC strip #3.(check run light on and plotter starts in forward direction).

Note:system should be up and operating at this point, and you are now ready to check for proper operation of entire system.

59. Enter 0 through 9 on TI keyboard and check corresponding print on Calcomp.
60. Enter S on TI keyboard to start sample.
61. Wait 3 minutes.
62. Enter E on TI keyboard to end sample.
63. After printout is completed check printout for indications of data from probes.
64. Enter S on TI keyboard to start sample.
65. Spray water on the IDC, 1DP, and ASP probes.
NOTE: When testing probes, verify that the optics are clear and the laser is functioning properly.
66. Enter E on TI keyboard to end sample.
67. Observe printout and Calcomp to make sure probes are putting out data.
68. Check the time lapse camera aperture and focus. Push the TLC circuit breaker in, check the time lapse camera for proper operation.
69. Pull the TLC circuit breaker.
70. Turn off the TLC toggle switch.
71. Turn the dewpoint to test, observe the data on the BMS. It should be increasing. After the needle on the dewpoint stabilizes, adjust the needle to center.

72. Turn the dewpoint to operate. Observe the BMS for decrease; the needle on the dewpoint should center after a few seconds.
73. Check the BMS and the DAS channels for proper content (Ref. Section 4.3).
74. Put the DAS switch on cloud probe.

NOTE: When testing the probes, verify that the optics are clear and the laser is operating properly.

75. Spray the cloud probe with water and check the PID scope for data.
76. Put the DAS switch on precipitation probe.
77. Spray the precipitation probe with water and check the PID scope for data.
78. Press forward and record switches on the Stancil-Hoffman.
79. Talk into the intercom and check the VU meter for a proper indication.
80. Perform a radio check on the project UHF or VHF radio and observe VU meter for indication.

NOTE: Due to antenna set up you can only have UHF or VHF for the mission but not both. To switch from one to the other requires changing the antenna and the co-ax jumper arrangement on the aft side of cabinet #1.

81. Push in Formvar circuit breaker.
82. On Formvar control head, turn on power.
83. Reset the footage counter.
84. Turn on the tape drive.
85. Press the over-ride switch to take up slack and start running.
86. Turn off the tape drive, Formvar should stop but it should maintain tension on Mylar.
87. Turn off the power switch on the control head.
88. Pull the Formvar circuit breaker.

4.1.3 Power Down Sequence. After all systems checks are complete the following procedure should be followed to power down the system.

1. Turn off the 1st and 2nd switches on AC strip #3.
2. Press the stop switch on the Kennedy.
3. After the record light stops flashing, press the rewind switch.

4. Turn off the Kennedy.
5. Turn off the BMS.
6. Turn off the dewpoint.
7. Turn off the Stancil-Hoffman.
8. Turn off the UHF or VHF radio.
9. Turn off the PID.
10. Press the stop switch on the DAS.
11. Press the rewind switch on the Pertec recorder.
12. Pertec recorder off.
13. Pertec formatter off.
14. Pull the circuit breakers for Topaz 1, 2, 3.
15. Turn off all toggle switches on the power panel.
16. Put GPU switch in full down position.
17. Turn off battery, and inverter switches in the cockpit.
18. Turn GPU off and disconnect it from the aircraft.
19. Re-connect one battery if the door is to be locked, and disconnect again.

4.2 Flight Checklist

The following are a list of procedures to be followed for pre-engine start, pre-takeoff and post takeoff phases of a research mission.

4.2.1 Pre-engine Start. The following are final checks to complete before the engines are started.

1. Formvar loaded.
2. Time lapse camera loaded.
3. Kennedy loaded.
4. Pertec loaded.
5. Stancil-Hoffman loaded.
6. Calcomp loaded, check pen.
7. TI loaded.
8. Clear loose objects, trash.
9. Remove probe covers, secure.
10. Check all power panel switches off and circuit breakers pulled except two marked main.
11. GPU/flight switch - flight position (full down).
12. Switch time code generator on batt position and set time.

4.2.2 Pre-Takeoff. After the engines are started and the Learjet crew verifies that the generator check is complete, the following sequence should be followed to bring the HAWADS on line.

1. LAC buss on - press reset - light on.
2. TLC on.
3. ASP on.
4. RAC buss on - press reset - light on.
5. 2D1 on.
6. 2D2 on.
7. Verify that the generator failure override switch is down.
8. LDC buss on - press reset - light on.
9. Topaz 3 breaker in.
10. FR/SP1 breaker in.
11. TLC breaker in.
12. Check all remaining toggle switches in this row down.
13. RDC buss on - press reset - light on.
14. Topaz 1 breaker in.
15. Topaz 2 breaker in.
16. UHF switch on.
17. TCG switch on.
18. Beacon switch on if required.
19. SS switch off.
20. AIP switch on.
21. SP1 temp switch on.
22. Remaining switches in this row down.

NOTE: Starting at the forward part of the cabin:

23. Dewpoint on.
24. Verify J-W off.
25. Stancil-Hoffman on, forward and record - check channels 1, 2, and 3 for VU reading.
26. Verify ASP power light on.
27. BMS on.
28. Kennedy power on.
29. Press the load switch on the Kennedy.
30. PID power on.
31. DAS power on.

32. Formatter power on.
33. Pertec power on - check 3rd light form bottom on.
34. Press load, verify write/enable, press load again.
35. Check Kennedy ready, light on.
36. Press record on BMS.
37. Check Pertec load light on.
38. Press on line - check on line light on.
39. Press DAS record.
40. Check BMS record light flashing.
41. Check DAS record light on.
42. Toggle switch on Transmuter up - check light on.
43. Verify plotter power light on.
44. Verify printer power light on.
45. 15v plotter supply on.
46. Verify all devices except computer and paper tape reader on.

* NOTE: This section may change depending on which real-time program is in use. Refer to the computer information section.

47. Turn computer AC switch on. Verify run light on. Others may also be on.

NOTE: If the plotter feeds paper backwards, turn off computer AC power.

NOTE: Plotter should feed forward, move the pen to the right, then start plotting.

48. Verify that plotter is plotting within approximately 30 seconds.
49. On the printer, type 1, S. wait 10 seconds.
50. Type E, printer should start printing out.
51. Check intercom - If above completed OK, system is go.

4.2.3 After Takeoff. The following sequence should be completed as quickly as feasible after takeoff.

1. Note the takeoff time.
2. J-W on.
3. Deice switches on, prior to first cloud entry or freezing level.
4. Formvar on and reset footage counter.
5. Verify ASP deice light on.
6. Open Formvar cabin vent.
7. Take up the slack on the Mylar and check feed.
8. Close the Formvar cover and secure it.
9. Check BMS all channels.
10. Check DAS all channels.
11. Check 1D end element voltages.
12. Check 2D end element voltages.
13. Operate the system as required.
14. Continually monitor all units for proper operation.

NOTE: If the plotter stops for longer than 30 seconds, the computer has probably blown its program. Check the condition of all equipment and execute the program load checklist. (Section 4.2.5)

- a. Run samples according to the flight plan.
 - b. Check systems operating properly.
 - c. Check all BMS and DAS channels from time to time.
 - d. Monitor the end element voltages frequently.
 - e. Monitor the 2D probe tips for laser light (when dark).
 - f. Monitor the 2D probes and wings for ice.
15. On final approach to landing
 - a. J-W off.
 - b. All deice switches off if outside temperature is above freezing.

4.2.4 After Landing. The following is the sequence to power down the HAWADS after the aircraft has touched down.

1. Wait until printer completes printout.
2. Turn the computer AC power off.
3. Press BMS stop.
4. Press DAS stop.

5. Wait until the record light stops flashing.
6. Verify DAS record light out.
7. Verify all device switches off.
8. Dewpoint off.
9. Verify J-W off.
10. Press file gap on Kennedy - wait for tape to stop.
11. Press the rewind switch on Kennedy.
12. Press the Pertec on line switch and the verify light out.
13. Press the rewind switch on the Pertec.
14. Verify the Kennedy load forward light out.
15. Kennedy off.
16. BMS off.
17. Verify the Pertec load light on.
18. If removing the tape, press rewind, if not, go to 20.
19. Wait for tape motion to stop.
20. Press the power switch on the Pertec and verify the light out.
21. Formatter off.
22. DAS off.
23. PID off.
24. 15V plotter supply off.
25. ASP off.
26. TLC off.
27. LAC buss off.
28. 2DP off.
29. 2DC off.
30. RAC buss off.
31. Verify all toggle switches in second row down (off).
32. TLC breaker out.
33. FR/SP1 breaker out.
34. Topaz 3 breaker out.
35. Verify main breaker in.
36. LDC buss off.
37. All toggle switches in third row off right to left until reaching the UHF.

38. Verify the time code generator battery switch to off.
39. Leave the UHF switch on as long as intercom is desired.
40. Topaz 2 breaker out.
41. Verify main breaker in.
42. When finished with the intercom, do the following:
 - a. Stencil-Hoffman - rewind.
 - b. Wait for the tape to stop then power off.
43. UHF toggle switch on, power panel off.
44. Topaz 1 breaker out.
45. RDC buss off.
46. Unload all tapes, collect all printer/plotter data.
47. Reload as necessary for next mission.

4.2.5 Program Reload. The following is the procedure to follow to reload a program from paper tape.

1. PID power off.
2. Computer power off.
3. Plug in the paper tape unit in place of PID plug on AC box #2.
4. Unplug the plotter cable (back of computer) and plug in the paper tape cable.
5. Carry out the power up sequence to the point of turning on the computer.
6. Touch the following touch sensitive switches:
 - a. clear.
 - b. S-reg/data.
 - c. 0001
 - d. sense.
7. Load the tape into the reader, turn on the reading light.
8. Touch the following touch sensitive switches
 - a. reset.
 - b. stop.
 - c. auto.
9. After the tape is loaded, the printer should type "ZBG".
10. Computer power off.
11. Rewind the paper tape.
12. Reader power off.

4.2.6 Recovery Procedures for the Real-Time Program. If the computer program should stop or lock-out the keyboard, a restart can be attempted by turning off the computer a-c power, and then cycling the computer on again after waiting about 3 seconds.

If the program still does not run properly, try the following recovery procedure at the computer console:

1. Press stop (verify STOP lamp is on).
2. Press reset (verify RESET lamp is flashing).
3. Press P (verify P lamp is on).
4. Press clear (data register lamps should be out).
5. Press 0, 1, 2, 6 (verify data register is set to 0126).
6. Press read/write (verify WRITE lamp on).
7. Press P (P lamp remains on).
8. Press read/write (WRITE lamp goes out).
9. Press stop (verify STOP lamp goes out).
10. Press run (verify RUN lamp comes on).

The plotter should feed and begin plotting within 30 seconds. If the plotter feeds backwards, press STOP and repeat steps 6 through 10 above.

If the program still does not operate properly, it must be reloaded from paper tape per the procedure in Section 4.2.5.

4.2.7 Operating Procedure for the Real Time Program (AMET3).

1. Load the program from paper tape per the paper tape program reload checklist (Section 4.2.5).

When the computer is powered up, the program will start running. If the plotter does not start, check for BMS power on (both 28VDC and 115 VAC, 60 Hz).

NOTE: Computer power may be turned off anytime without destroying the program stored in memory except before the printer has completed outputting the entire data block.

2. The TI keyboard key assignments presently defined are:
 - B - prints the BMS input buffer contents
 - D - Enters the date by depressing numerals in the order: YY MM DD (NOTE: the operator must wait for an acknowledgement between digits)

- E - end cloud sample period and begin data output to printer
- H - followed by an "S" or "L" enables the title mode which includes printing the Lear 36 title at head of data block (selecting H again deletes title mode)
- L - outputs Date, Time, TAS, Altitude, Temp., and Dewpoint
- R - prints contents of error registers
- S - starts/restarts cloud sample period
- Z - enters Debug routine (ZBG)
- A, C, F, G, M, T, or X - used in simulator mode (Section 4.2.8)
- 0-9 - select appropriate crystal type (unless following a "D")

The crystal type numbers are defined as follows:

Keyboard input and plotter output	Crystal type	Printer Output
0	Rain	RN
1	Wet snow	WS
2	Large snow	LS
3	Small snow	SS
4	Bullet rosettes	BR
5	Columns	CL
6	Needles	NE
7	RMC-1	R1
8	RMC-2	R2
9	zero all probe count values	(Blank)

3. Normal in-flight operation uses keys S, E, L, and 0 through 9 repeatedly.. H and D modes are usually selected only once per flight.
4. The remaining keys are available to facilitate equipment troubleshooting and program debugging.

4.2.8 Operating Procedure using the BMS Simulator Program (SMULAT).

1. To activate the simulator mode, while the real time program is running, select either an "A", "F", or "M" key on the TI keyboard to set up the initial conditions, followed by a "T" to begin the simulation and start the simulator Time-of-Day and Elapsed-Time clocks. The BMS equipment may be turned on or off, but its input data cable must be connected at the computer.

2. Once simulation has begun, additional keys can be selected to control the program operation.
3. Keys defined in program 'SMULAT' are:
 - A - automatically increments probe counts every second. A complete simulation of cloud profile probe data takes 14 minutes. Note that the program will continue to simulate indefinitely until deselected.
 - M - allows manual control of probe values (and clears input data to zero) by enabling keys "F", "C", "F", and "X".
NOTE: This does not reset the simulator clock.
 - F - sets probe values to a maximum (9999).
 - C - sets a linearly decreasing count in channels 1 through 15 which is increased linearly each time "C" is reselected.
 - G - steps between three different values for P, ΔP , TT, and T_d data corresponding to sea level, normal flight altitude, and maximum flight altitude.
 - X - sets the simulator probe values to zero.
4. To exit the simulator and return to the real time program, select "T" again. The printer will execute a carriage return and line feed. This also clears all simulator control settings.

NOTE: If "T" is selected prior to a valid initial-condition key ("A", "F", or "M"), an error message will be printed and the key will be ignored.

If the program is in the simulator mode when power is turned off, it will remain in simulator mode when power is restored. The operator must then select return to real time mode.

4.3 Data Acquisition Channel Assignments

The data displayed for each variable should be monitored from time to time, as described in Section 4.2.3. The following is a listing of the current data channel assignments for each variable on the BMS.

TABLE 41 BMS CHANNEL ASSIGNMENTS

<u>PROBE</u>	<u>CHANNEL</u>	<u>REMARK</u>
1	0	Formvar footage
1	1 thru 15	Data counts
2	0	9333
2	1 thru 15	Data counts
3	0	Elapsed time
3	1 thru 15	Data counts
AUX DATA	0	8192
" "	1	Pressure (P)
" "	2	Differential Pressure (ΔP)
" "	3	Temperature (Rosemont) (T)
" "	4	Dewpoint (Td)
" "	5	Liquid water content (J-W) (LWC)
" "	6	Analog spare
" "	7	TWCI reference freq.
" "	8	TWCI sense freq.
" "	9	TWCI
" "	10	Minutes and seconds.
" "	11	Hours
" "	12	Spare
" "	13	Spare
" "	14	TWCI temp
" "	15	TWCI temp

The following is a corresponding listing for the DAS.

TABLE 4.2 DAS CHANNEL ASSIGNMENTS

<u>SIZE</u>	<u>WORD</u>	<u>SUB COM</u>	<u>REMARKS</u>
0	0	0	Spare/seconds x 10 K
0	0	1	2DC overload percentage
0	0	2	2DC end element #1
0	0	3	2DC end element #32
0	0	4	2DC -15v DC supply
0	0	5	2DC -12v DC supply
0	0	6	2DC +5v DC A supply
0	0	7	2DC +5v DC B supply
0	0	8	2DC +15v DC supply
0	0	9	2DC Temperature
0	1	0	Seconds x 1
0	1	1	2DP overload percentage
0	1	2	2DP end element #1
0	1	3	2DP end element #32
0	1	4	2DP -15v DC supply
0	1	5	2DP -12v DC supply
0	1	6	2DP +5v DC A supply
0	1	7	2DP +5v DC B supply
0	1	8	2DP +15v DC supply
0	1	9	2DP Temperature
0	2	0	Spare/Hours
0	2	1	2DC Total count
0	3	0	Minutes and seconds
0	3	1	2DP Total count
0	4	0	Pressure (P)
0	5	0	Differential Pressure (ΔP)
0	6	0	Temperature (T)
0	7	0	Dewpoint Temperature (T_d)
0	8	0	Liquid water content (LWC)

4.4 Ground Support Systems

The printer plotter and audio playback unit are available for immediate processing of mission data. The data handling is illustrated in the block diagram in Figure 4.1. The following are instructions to operate the ground support equipment.

4.4.1 Printer Plotter. To produce a hard copy of the 2D record proceed according to the following.

1. Load the tapes from the 2D system onto the tape transport with the file protect ring removed.
2. Place the switches on the interface panel in the following positions:
 - a. Forward/reverse; forward
 - b. Read/stop; read
 - c. Copy/off; copy (unless it is desired to seek a known time section for copying)
 - d. Images/both/slow data; as desired
 - e. Image size; as desired.
3. Place the roll/fanfold toggle on the printer plotter sub-panel behind the front door in the appropriate position.
4. Switch on power to the PMS interface, printer plotter, tape transport and formatter.
5. Press the "load" button on the tape transport to energize the tape tension system. Press it again and the tape will move to the load point and the load lamp will light.
6. Press "on line" button on the tape transport to begin operation. The printer-plotter will start gurgling and after a few seconds the tape will start and be copied onto the printer-plotter. The decimal display will indicate the four most significant digits of the time work recorded at the beginning of each tape record. If known sections of the data are desired, place the "copy/off" switch in the off position until the desired time is reached.
7. To copy a section already past on the tape, switch to reverse and copy off to move the tape backwards. The decimal display does not read correctly in reverse, so switch to forward to see where the tape is.

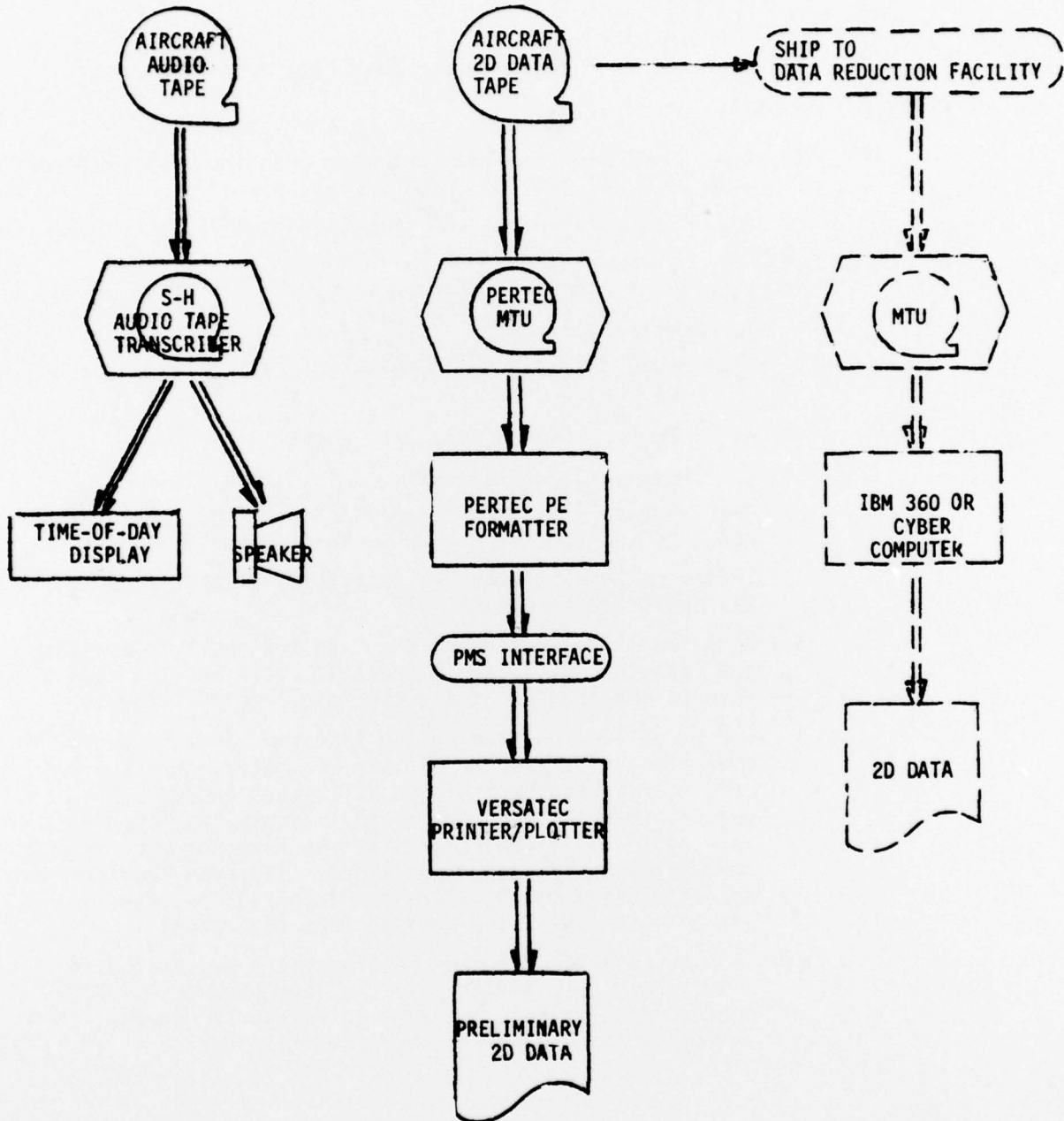

Figure 4.1 Block diagram, ground support equipment.

8. To discontinue operation, switch the "read/stop" toggle to stop. The operation will stop after the current record. To resume, switch to the read position and cycle the "on line" button on the tape transport. Operation is always initiated by an "off line" to "on line" change on the tape transport, provided the "read/stop" toggle is in the read position. If the tape is at the load point and reverse is selected on the "forward/reverse" toggle, the system will not operate until forward is selected. This prevents inadvertent unloading of the tape.

NOTE: The tape does not automatically stop at the end-of-tape occurs, so the operator must be alert when the tape nears this point.

Whenever the end of data on tape is passed, the tape will run continuously and switching the read/stop toggle to the stop position will do nothing. At this point, the operator must take the tape transport off line (by pressing the on line button) and press the rewind button to reverse the tape. Further operation will not be possible until the tape stops at load point.

9. To unload a tape from the transport, take the transport off line and press the rewind button. If the tape is at load point, it will run off the take-up reel. If not, it will stop at load point and the rewind button must be pressed again to unload.

4.4.2 Audio Tape Playback Procedure. To transcribe an audio tape from the HAWADS, proceed as follows:

1. Turn the power on.
2. Load the tape on the left turntable so the tape will come off counterclockwise.
3. Unwind about 3 ft of tape and thread it following the tape path indicated by lines. The oxide (dull) side of the tape must be up toward the heads.
NOTE: the wheels will be hard to rotate with brakes applied.
4. Secure the tape on the takeup reel by winding several turns (counterclockwise). Take up all slack in the tape. Be sure the threading is proper and the tape is not twisted.
5. Press the forward button; the tape should start moving at normal speed. The recorded time should appear in the time reader display.
6. Select the channels and audio levels desired for the three audio tracks.

7. To move the tape forward or backward at high speed, press the manual search switch and rotate the manual search knob as desired. The time will be displayed correctly in either direction. When approaching the desired time, rotate the control knob to the zero position to slow the tape. Press the stop switch to stop the tape.
8. To move the tape backwards a small amount, press the stop switch and wind the supply reel backwards manually. The audio will be heard and will, with practice, signal where to stop the tape.
9. If you wish to audibly monitor the fast forward or reverse motion, press the cue button.

5.0 MAINTENANCE

5.1 Maintenance Procedures

The procedures described above are designed to reveal any calibration or operational problems in the HAWADS. If such faults are discovered, the appropriate vendor manual should be consulted. Table 5.1 gives a listing of the recommended documentation for troubleshooting and maintenance.

5.2 Spares

Because of the sites for HAWADS operations are usually remote, it is recommended that the most commonly used spares be kept with the system. The recommended spares lists are given in Table 5.2.

Table 5.1 List of Recommended Vendor Documentation

1. Computer Automation Inc., 18651 Von Karman, Irvine, CA 92664
 - a. Naked mini LSI series computer handbook
 - b. LSI software manual
 - c. 16 bit input/output module, model 13213-00
 - d. Utility module, model 14223-00
 - e. Paper tape reader interface manual, no. 91-50223-11A0
2. Particle Measuring Systems, Inc., 1855 South 57th Court, Boulder, CO 80301
 - a. Data acquisition system DAS-2D
 - b. 2D optical array spectrometer probe, OAP-2D-C
 - c. 2D optical array spectrometer probe, OAP-2D-P
 - d. Particle sizing spectrometer system
3. Texas Instruments Inc., Digital Systems Div., PO Box 1444, Houston, TX 77001
 - a. Operating instructions manual, silent 700 electronic data terminals, model 733 ASR/RSR manual no. 959227-9701, revised 1 Dec., 1975.
 - b. Maintenance manual, manual no. 960129-9701, revision D, revised 1 Nov., 1975
4. Meteorology Research, Inc., P.O. Box 637, Altadena, CA 91001
 - a. Airborne continuous particle sampler manual
5. Pertec, Peripheral Equipment Div., 9600 Irondale Ave., Chatsworth, CA 91311
 - a. Tape transport operation and maintenance manual, Model 76409, serial 350-406-057
 - b. Phase encoded formatter operation and maintenance manual, model F649-40, serial 350-707-067
6. Topaz Electronics, Inc., 3855 Ruffin Road, San Diego, CA 92123
 - a. Static inverter operation and instruction manual, W series, model 1000 6W-28-60-115, part 9090
 - b. Static inverter operation and instruction manual, Z series, model 1000GZ-28-60-115, part 5322
7. EG&G, Environmental Equipment Division, 151 Bear Hill Road, Waltham, MA 02154
 - a. Instruction manual, model 137-C3
8. California Computer Products, Inc., 244 LaRoma, Anaheim, CA 92801
 - a. Technical manual, Calcomp pen and paper users guide, part number 10118-901-003-2
 - b. Technical manual, model 565 digital incremental plotter, part number 10018-901-003-1
9. Stancil-Hoffman Corporation, 921 N. Highland Ave., Hollywood, CA 90038
 - a. Multichannel recorder-reproducer, model CRM 7/14/28 series
 - b. Operation and maintenance instructions, digitime

10. Excello Corporation, Remex Division, 1733 Alton St., Santa Anna, CA 92705
 - a. Technical manual, tape reader, models RR-6300 BAX/66X, RR-6300 BBX/66X and TRM-301AF-2.
11. Tektronix, Inc. PO Box 500, Beaverton, OR 97005.
 - a. Instruction manual, Model 604 monitor.
12. Magnavox Company, Fort Wayne, IN
 - a. Intermediate Maintenance instructions with illustrated parts breakdown, TO 12R2-2ARC-150-2
13. Fairchild Camera and Instrument Corp., 464 Ellis St., Mountain View, CA
 - a. Instruction manual for digital panel meters.
14. Epsilon Laboratories Inc., 4 Preston Court, Bedford, MA 01731
 - a. Instruction manual - camera annotation system
15. Ferkin Elmer Corp., Aerospace Systems Div., 2771 N. Garey Ave., Pomona, CA 91767
 - a. Technical order A2-4-19-3 Overhaul manual
 - b. Technical order A2-4-19-4 Illustrated parts catalog
16. Rosemount Engineering Co., P.O. Box 35129, Minneapolis, MN 55435
 - a. Technical data, model 510BS
 - b. Technical data, model 102 AVIAP
17. Validyne Engineering Corp., 194146 Londelius St., Northridge, CA 91324
 - a. Technical data, model P24
18. Baccarach Instrument Co. 2300 Eghorn Ave, Mountain View, CA
 - a. Instruction manual for J-W liquid water content indicator, model LWH, manual number 61WCO 0621

Table 5.2 List of Recommended Spare Parts
And Supplies for HAWADS
Prices for December, 1975

CALCOMP:		\$ 57.00
1	90-015 cable kit	
8	PB4 pens	
KENNEDY:		1,230.75
4	139-0214-101 Lamp	5.00
5	151-0132-001 fuse	.75
1	190-2224-001 PC Assy	30.00
1	190-2224-002 PC Assy	30.00
1	190-2252-011 PC Assy	100.00
1	190-2436-005 PC Assy	100.00
1	190-2528-103 PC Board	60.00
1	190-2551-001 PC Board	100.00
1	190-2555-001 PC Board	100.00
2	190-2607-001 Assy PC	15.00
1	190-2654-101 Assy PC	75.00
1	190-2655-103 Assy PC	100.00
1	190-2677-112 Assy PC	100.00
1	190-3454-001 PC BD	55.00
1	190-3620-001 Assy PC	70.00
1	190-2224-001 Assy PC	30.00
1	K21-Maint Kit	35.00
1	190-2273-001 PCB	135.00
1	190-3392-001 PCB	90.00
PERTEC:		2,565.50
1	102382-01 Tape Path Alignment tool	75.00
1	103259-01 Head adj stool	25.00
1	101292-31 PCBA, DATA H	660.00
1	505-1801 switch power	3.50
1	505-1803 switch load	3.50
1	505-1804 switch, on-line	3.50
1	505-1805 switch rewind	3.50
1	505-1806 switch, WRT-EN	3.50
1	505-1808 switch, forward	3.50
1	505-1809 switch reverse	3.50
1	505-1827 switch 1600 CPT	3.50
1	102021-01 harness switch	4.50
1	101381-01 PCBA, PE read	940.00
1	101386-01 PCBA, PE write	575.00
1	101367-02 PCBA, Interconnect	155.00
1	102096-05 PCBA, Fixed Oscillator	43.00
1	102094-02 PCBA single tracking	60.00
REMEX:		466.90
1	110453-001 Light source Assy	42.00
1	110271-001 PCB	301.90
1	110459-001 R/H Assy	79.90
1	704520-109 Reg.	5.80
1	704204-120(MU4053)Transistor	15.00

REMEX (continued)

1	110474-001 Switch	11.45
1	715058-120 Switch	3.50
1	715061-400 switch	7.35

STANCIL-HOFFMAN

1	13-142 IC Small parts kit		\$ 341.00
---	---------------------------	--	-----------

TOPAZ

32	2W61105 transistors	30.00	952.85
16	2W12868 Zener diode	2.20	
4	2W DTG110 Transistors	3.65	
2	Printed circuit card Assy	864.00	
2	Capacitors 96000 mfd	53.00	

PMS

2	D-15-35 power supply 15V Acopian		4,235.00
1	5E250 power supply, 5V		
2	2D, PMS-500 PC board modules		
1	Assortment of 2D capacitors 1pf,2pf,3pf,4pf		
8	pms-152 photodetector modules		
1	2D, PIN 2901 photodiode array		
1	2D, 12E70 power supply -12v		
1	2D laser supply & H.V. transformer		
3	2D PMS 260 photodetector modules		
1	2D PMS 230 P.C. board		
1	2D PMS 240 p.c. board		
1	2D PMS 250 p.c. board		
1	200Y PIN2901 + PMS-180B p.c. board + photodiode array		
1	MM-5P, +5V power Mate Supply		
1	200Y laser power supply		
3	200Y HV transformer		
1	PMS-170 size encoder module		
1	PMS-172 size encoder module		
1	PMS-174 strobe and reset module		
1	PMS-176A line driver module		
1	PMS-200 p.c. board		
1	ASSP-100, laser power supply		
1	large extender board		
1	plug 26-159-24		
1	socket 26-190-24		
1	P.C. card socket, large		
1	large extender board		
1	small extender board		
1	vial 6-13 Polyvinyltoluene 2.02 mm		
1	6-15 polyethylene 6.0 mm		
1	SR-8 Polystyrene DUB 8.0 mm		
1	SR-15 Polystyrene DUB 15.0 mm		
1	SR-20 Polystyrene DUB 19.0 mm		
1	SR-40 Polystyrene DUB 40 mm		
1	SR-50 Polystyrene DUB 50 mm		
1	SR-65 Polystyrene DUB 65 mm		
1	SR-80 Polystyrene DUB 80 mm		
1	SR-100 Polystyrene DUB 100 mm		
1	SR-115 Polystyrene 105-125 mm		
1	SR-230 Polystyrene 210-250 mm		
1	SR-425 Polystyrene 350-500 mm		
1	SR-330 Polystyrene 310-350 mm		
1	SR-550 Polystyrene 500-600 mm		

COMPUTER AUTOMATION

1	11560-16 CORE 1200 PCB	3,050.00
---	------------------------	----------

Intercom Amplifier

3	TELEX Head Set	396.00
---	----------------	--------

1	Ft 25 Intercom Amplifier	264.00
---	--------------------------	--------

SPARE PARTS TOTAL

\$13,559.00

REFERENCES

- Knollenberg, R. G., 1976: Three New Instruments for Cloud Physics Measurements: The 2D Spectrometer, The Forward Scattering Spectrometer Probe, and the Active Scattering Aerosol Spectrometer. International Conference on Cloud Physics, 554-561.

APPENDIX A

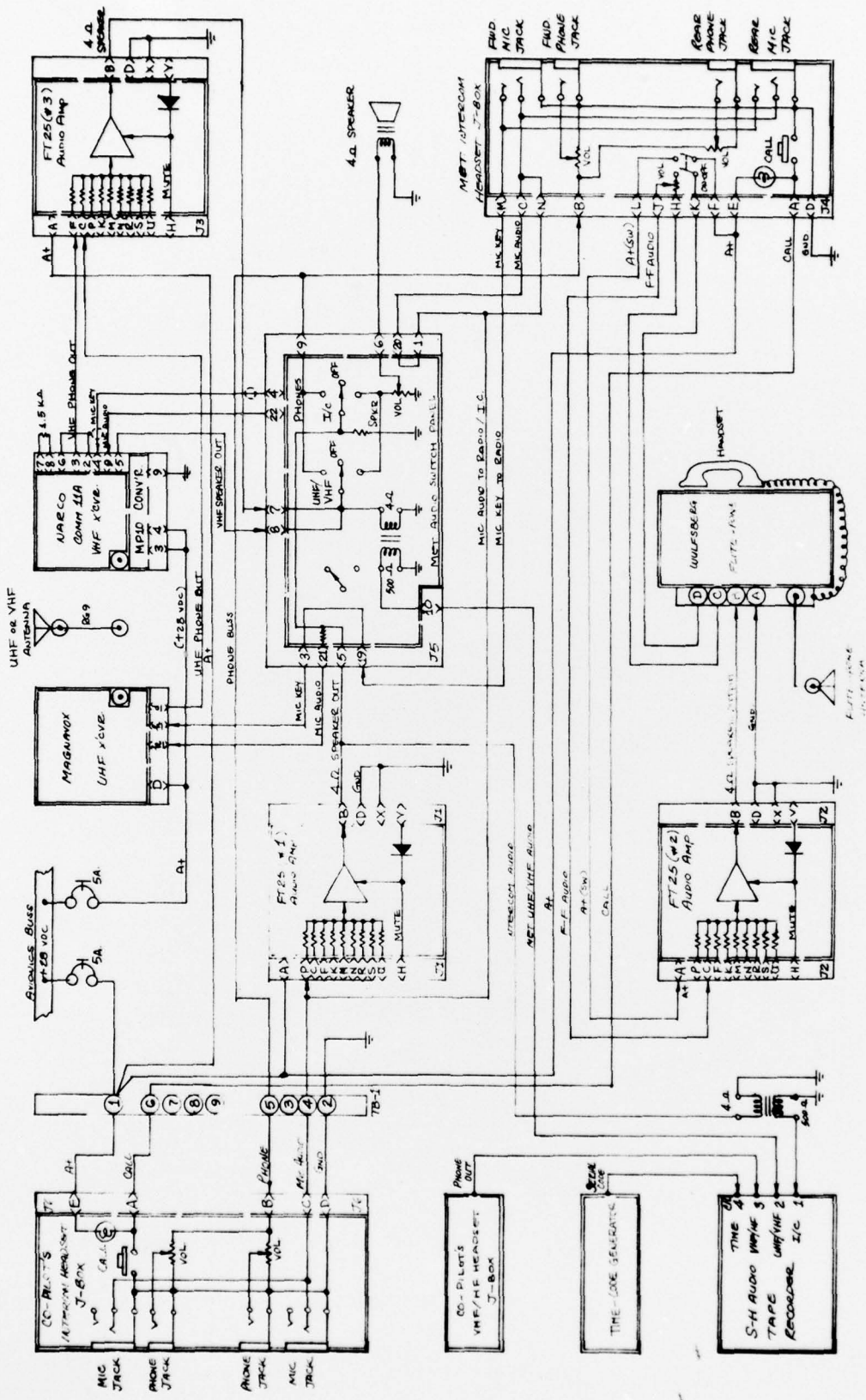

Schematic drawing for Audio System.