

AD-A038 512

HARRIS CORP MELBOURNE FLA ELECTRONIC SYSTEMS DIV  
DEVELOPMENT OF SOLID-STATE TRANSPORTABLE SATELLITE COMMUNICATIO--ETC(U)  
MAR 74

F/G 17/2

DAAB07-72-C-0097

NL

UNCLASSIFIED

1 OF 2  
AD  
A038512

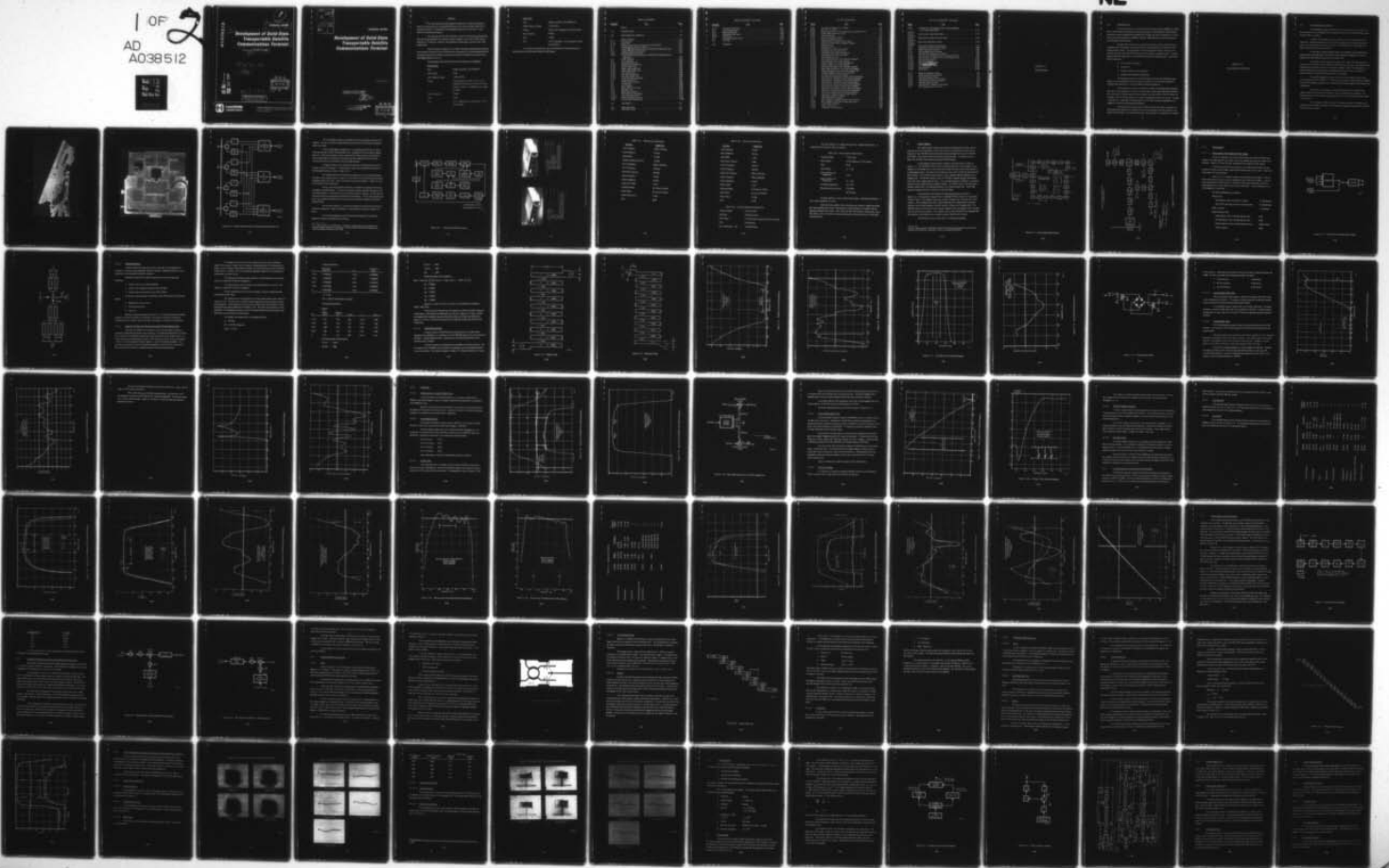

012



ADA 038512

6

# Development & Transport Communications

Contract No. DAAB-87-72

15

11

15 Mar 74

12

140p.

AD No. ~~1~~  
DDC FILE COPY

408 97

### DISTRIBUTION STATEMENT

Approved for public release  
Distribution Unlimited

87924



**HARRIS**  
COMMUNICATIONS AND  
INFORMATION HANDLING

HARRIS  
P.O. Box  
\* (former)

APPROSSION for		
K710	Write Section	<input checked="" type="checkbox"/>
END	Buff Section	<input type="checkbox"/>
UNANNOUNCED		<input type="checkbox"/>
IDENTIFICATION		
.....		
.....		
IDENTIFICATION/AVAILABILITY CODES		
.....		
Dist.	AVAIL.	and/or SPECIAL
A		

**TECHNICAL REPORT**

# ***Development of Solid-State Transportable Satellite Communications Terminal***

15 March 1974

APPROVED FOR PUBLIC RELEASE  
DISTRIBUTION UNLIMITED

*[Signature]*  
(K. NEW)  
USASATCOMA

4/1/77

U.S. Army Satellite Communications Agency  
AMCPM-SC-4C (Mr. K.J. New-10894)  
Fort Monmouth, N.J. 07703

DDC  
RECEIVED  
APR 21 1977  
D

87924

## ABSTRACT

This report describes the development by Radiation of X-band solid-state frequency converters as part of a transportable terminal for use with the military DSCS-H communications satellite. This equipment was developed under contract with the U.S. Army Satellite Communications Agency.

The converters are fully self-contained in two 3-1/2 inch rack-mounting drawers. They provide the capability for translating a signal anywhere in the 7.25-7.75 GHz receive band down to 70 MHz and, similarly, of translating a 70 MHz signal up to the 7.9-8.4 GHz transmit band.

Hybrid microwave integrated circuit (HMIC) techniques were employed extensively in the terminal converters to aid in minimizing size and weight and in enhancing reproducibility. The actual construction is a blend of microstrip and stripline distributed circuits and miniaturized lumped-element circuits.

Key parameters of the solid-state terminal converters are as listed below.

### Downconverter

Type:	Double-conversion, with 700 MHz IF
Noise Figure:	15 dB
Input Frequency Range:	7.25-7.75 GHz
Tuning:	Direct frequency selection with front panel thumbwheel switches which control an internal frequency synthesizer for 500 kHz tuning steps at X-band.
Output Frequency:	70 MHz
Gain:	35 dB
Size:	3-1/2 inches high x 19 inches deep, 19 inch rack mounting

Upconverter

Type:	Double-conversion, with 700 MHz IF
Output Frequency Range:	7.9-8.4 GHz
Tuning:	Same as, but independent of, downconverter
Input Frequency:	70 MHz
Gain:	-10 dB
Size:	3-1/2 inches high x 19 inches deep, 19 inch rack mounting

It is projected that production costs of the solid-state terminal downconverter and upconverter would be approximately \$10,000 apiece.

## TABLE OF CONTENTS

<u>Paragraph</u>	<u>Title</u>	<u>Page</u>
	Abstract . . . . .	i
1.0	INTRODUCTION . . . . .	1-2
2.0	DEVELOPMENTAL APPROACH. . . . .	2-2
2.1	Combiner Module . . . . .	2-12
2.1.1	Downconverter . . . . .	2-15
2.1.2	Upconverter . . . . .	2-35
2.1.3	Combiner Upconverter and Downconverter Test Results . . . . .	2-42
2.2	Fixed-Frequency Multiplier Module . . . . .	2-57
2.3	X-Band/700 MHz Downconverter and 700 MHz/X-Band Upconverter . . . . .	2-59
2.3.1	X-Band/700 MHz Downconverter . . . . .	2-62
2.3.2	700 MHz/S-Band Upconverter . . . . .	2-69
2.3.3	X-Band/700 MHz Downconverter and 700 MHz/X-Band Upconverter Test Results . . . . .	2-74
2.4	5 MHz Oscillator . . . . .	2-80
2.5	VHF Synthesizer . . . . .	2-80
2.5.1	Summing Loop RF Card . . . . .	2-85
2.5.2	Summing Loop Analog Card . . . . .	2-85
2.5.3	Coarse Loop RF Card . . . . .	2-85
2.5.4	Coarse Loop Analog Card . . . . .	2-86
2.5.5	Coarse Loop Divider Card . . . . .	2-86
2.5.6	Fine Loop RF Card . . . . .	2-86
2.5.7	Fine Loop Analog Card . . . . .	2-86
2.5.8	Fine Loop Divider Card . . . . .	2-86
2.5.9	5 MHz Distribution Amplifier . . . . .	2-87
2.6	Programming Circuit . . . . .	2-87
2.7	L-Band Agile Oscillator . . . . .	2-87
2.8	X5 Multiplier . . . . .	2-88
2.9	Power Supplies . . . . .	2-88
2.10	Out-of-Lock Circuit Card . . . . .	2-89
2.11	630 MHz Filter . . . . .	2-90
2.12	Equalization Network . . . . .	2-90
2.13	SHF Filter Network Designs . . . . .	2-93
2.13.1	Local Oscillator Filters . . . . .	2-93
2.13.2	Transmit and Receive Filters . . . . .	2-96
2.14	Final Physical Configuration . . . . .	2-100
3.0	TEST RESULTS . . . . .	3-2
3.1	Upconverter Tests . . . . .	3-2
3.1.1	Amplitude Flatness . . . . .	3-2

TABLE OF CONTENTS (Continued)

<u>Paragraph</u>	<u>Title</u>	<u>Page</u>
3.1.2	Differential Time Delay . . . . .	3-6
3.2	Downconverter Tests . . . . .	3-10
3.2.1	Amplitude Flatness . . . . .	3-10
3.2.2	Differential Time Delay . . . . .	3-17
3.2.3	Noise Figure . . . . .	3-17
3.3	Synthesizer Spectral Purity . . . . .	3-21
3.4	Link Tests . . . . .	
4.0	SUMMARY . . . . .	4-2

## LIST OF ILLUSTRATIONS

<u>Figure</u>	<u>Title</u>	<u>Page</u>
2.0-1	Four-Aperture Phased-Array Antenna . . . . .	2-3
2.0-2	Rear View of Antenna . . . . .	2-4
2.0-3	Multiple Aperture Satellite Communications Terminal RF Unit . . . . .	2-5
2.0-4	Single-Aperture Baseline System . . . . .	2-7
2.0-5	Converter Drawers . . . . .	2-8
2.1-1	Downconverter Block Diagram . . . . .	2-13
2.1-2	Upconverter Block Diagram . . . . .	2-14
2.1-3	Combiner/Divider Module Block Diagram . . . . .	2-16
2.1-4	Combiner/Divider Module Schematic Diagram . . . . .	2-17
2.1-5	Wideband Filter . . . . .	2-22
2.1-6	Narrowband Filter . . . . .	2-23
2.1-7	Wideband Filter Amplitude Response . . . . .	2-24
2.1-8	Wideband Filter Phase Deviation . . . . .	2-25
2.1-9	Narrowband Filter Amplitude Response . . . . .	2-26
2.1-10	Narrowband Filter Phase Deviation . . . . .	2-27
2.1-11	Double Balanced Mixer . . . . .	2-28
2.1-12	Local Oscillator Reject Filter Amplitude Response . . . . .	2-30
2.1-13	Local Oscillator Filter Phase Response . . . . .	2-31
2.1-14	Harmonic Reject Filter Amplitude Response . . . . .	2-33
2.1-15	Harmonic Reject Filter Phase Response . . . . .	2-34
2.1-16	Upconverter Wideband Filter Amplitude Response . . . . .	2-36
2.1-17	Upconverter Narrowband Filter Amplitude Response . . . . .	2-37
2.1-18	Upconverter/Downconverter 70 MHz Leakage Path . . . . .	2-38
2.1-19	IF Reject Highpass Filter Amplitude Response . . . . .	2-40
2.1-20	LO Reject Filter Amplitude Response . . . . .	2-41
2.1-21	Downconverter Narrowband Channel Amplitude Response . . . . .	2-45
2.1-22	Downconverter Wideband Channel Amplitude Response . . . . .	2-46
2.1-23	Downconverter Narrowband Channel Phase Response . . . . .	2-47
2.1-24	Downconverter Wideband Channel Phase Response . . . . .	2-48
2.1-25	Downconverter Narrowband Channel Delay Response . . . . .	2-49
2.1-26	Downconverter Wideband Channel Delay Response . . . . .	2-50
2.1-27	Upconverter Narrowband Channel Amplitude Response . . . . .	2-52
2.1-28	Upconverter Wideband Channel Amplitude Response . . . . .	2-53
2.1-29	Upconverter Narrowband Channel Phase Response . . . . .	2-54
2.1-30	Upconverter Wideband Channel Phase Response . . . . .	2-55
2.1-31	Upconverter Saturation Response . . . . .	2-56
2.2	FFM Module Block Diagram . . . . .	2-58
2.3-1	Block Diagram of X-Band/700 MHz Downconverter . . . . .	2-60
2.3-2	Block Diagram of 700 MHz/X-Band Upconverter . . . . .	2-61
2.3-3	X-Band Mixer Geometry . . . . .	2-64
2.3-4	Layout of the Filter . . . . .	2-66
2.3-5	15-Element Filter Geometry . . . . .	2-72

LIST OF ILLUSTRATIONS (Continued)

<u>Figure</u>	<u>Title</u>	<u>Page</u>
2.3-6	15-Element SST 154 Bandpass Filter Frequency Response Curve With Compensation . . . . .	2-73
2.3-7 to 2.3-10	Downconverter Amplitude Flatness . . . . .	2-75
2.3-11 to 2.3-15	Downconverter Differential Time Delay . . . . .	2-76
2.3-16 to 2.3-19	Upconverter Amplitude Flatness . . . . .	2-78
2.3-20 to 2.3-24	Upconverter Differential Time Delay . . . . .	2-79
2.5-1	Synthesizer Functional Block Diagram . . . . .	2-82
2.5-2	Indirect Frequency Synthesis . . . . .	2-83
2.5-3	VHF Synthesizer Block Diagram . . . . .	2-84
2.12	700 MHz Gain Equalization Network . . . . .	2-92
2.13-1	Test Fixture for 5-Element Thin-Film Microwave Filter . . . . .	2-95
2.13-2	Test Fixture for 15-Element Thin-Film Microwave Filter . . . . .	2-99
2.14-1	Downconverter Modules . . . . .	2-101
2.14-2	Upconverter Modules . . . . .	2-102
2.14-3	Fixed Frequency <del>Module</del> <sup>MULTIPLIER</sup> . . . . .	2-103
2.14-4	VHF <del>Synthesizer</del> <sup>SYNTHESIZER</sup> Module . . . . .	2-104
2.14-5	Downconverter . . . . .	2-105
2.14-6	Upconverter . . . . .	2-106
3.1-1	Reference Amplitude Flatness . . . . .	3-3
3.1-2	Upconverter Amplitude Flatness . . . . .	3-3
3.1-3	Reference Delay Variation . . . . .	3-7
3.1-4	Upconverter Differential Time Delay . . . . .	3-8
3.2-1	Downconverter Amplitude Flatness . . . . .	3-11
3.2-2	Reference Delay Variation . . . . .	3-14
3.2-3	Downconverter Differential Time Delay . . . . .	3-15
3.3	VHF Synthesizer Spectral Purity . . . . .	3-20

SECTION 1.0  
INTRODUCTION

## 1.0 INTRODUCTION

The work described in this report was performed under Contract DAAB07-72-C-0097 for the United States Army Satellite Communications Agency (USASATCOMA), Fort Monmouth, New Jersey, during the period from December 1971 through June 1973, by Radiation, a division of Harris-Intertype Corporation, Melbourne, Florida. Additional work was done subsequently under Radiation internal funding.

The goal of this contract was to determine the extent to which hybrid microwave integrated circuit technology, or extensions thereof, could be applied to an X-band satellite communications terminal. The development of a multiple-aperture terminal, utilizing a GFE antenna, was planned by USASATCOMA to provide the baseline development goals. The design priorities that were established in the USASATCOMA Technical Guidelines were, in decreasing order of importance:

- a. Up- and Down-Converters
- b. Synthesizers
- c. Transmit and Receive RF Components
- d. IF Beam Forming (Aperture Combining)

The development plan was evolved by budgeting the terminal performance goals among the various subsystems; this initial step was necessary in order to provide compatible interfaces that would result in overall acceptable terminal performance.

The main body of this report, contained in Section 2.0, describes the development work which was accomplished to reach the technical goals. Basic design trade-offs and decisions that were made, the design approach for each module, and a description of the final design are discussed. Section 3.0 then describes the results of measurements made on the system. Included in Section 4.0 is a discussion of the applicability of the HMIC technology developed on this program to future low-cost transportable terminals.

Additional tests, not a part of the contract for which this report is prepared, are being performed by Radiation to determine bit error rate performance with the converters interfaced with PSK modems. The results of these tests will be reported in a supplement to this report.

SECTION 2.0  
DEVELOPMENTAL APPROACH

## 2.0 DEVELOPMENTAL APPROACH

The development program established by this contract was set up to utilize thin-film microwave circuit technology, wherever applicable, for a military communications system using the DSCS-II satellite.

A number of advantages should be realizable with a terminal using thin-film technology. Without having to accept any significant compromise in communications performance, one would expect to be able to provide a terminal of small size, light weight, low power consumption and low life cycle cost.

On this basis, a baseline terminal system was configured, and the required subsystem elements were identified. This baseline terminal system was designed to utilize the features of the GFE antenna structure shown in Figure 2.0-1.

The antenna is a four-aperture low-profile unit. Figure 2.0-2 shows the rear of the antenna with a transmit-receive module on each of the four apertures. The available power radiated from this antenna is the sum of the power available at each of the four apertures. A similar addition of the received signal is available for the four receivers. This ability to aperture-combine the signals is provided at the IF in this system.

The aperture combining is shown in the RF unit block diagram, Figure 2.0-3, to be accomplished at the 700 MHz IF. A detailed set of performance parameters were budgeted to each of the subsystem elements, and the detailed design and development of the elements was implemented.

Fairly early in the program, the first DSCS-II satellites were found to have stability problems that rendered the high-gain, narrow-coverage antennas unusable. This necessitated the use of the earth-coverage antennas only, with a resulting loss of about 16 dB in antenna gain.

The reduction of 16 dB in the system link margin caused by the temporary non-availability of the satellite high-gain antenna stimulated a program redirection and a modification of the baseline system.

GFE  
ANTENNA

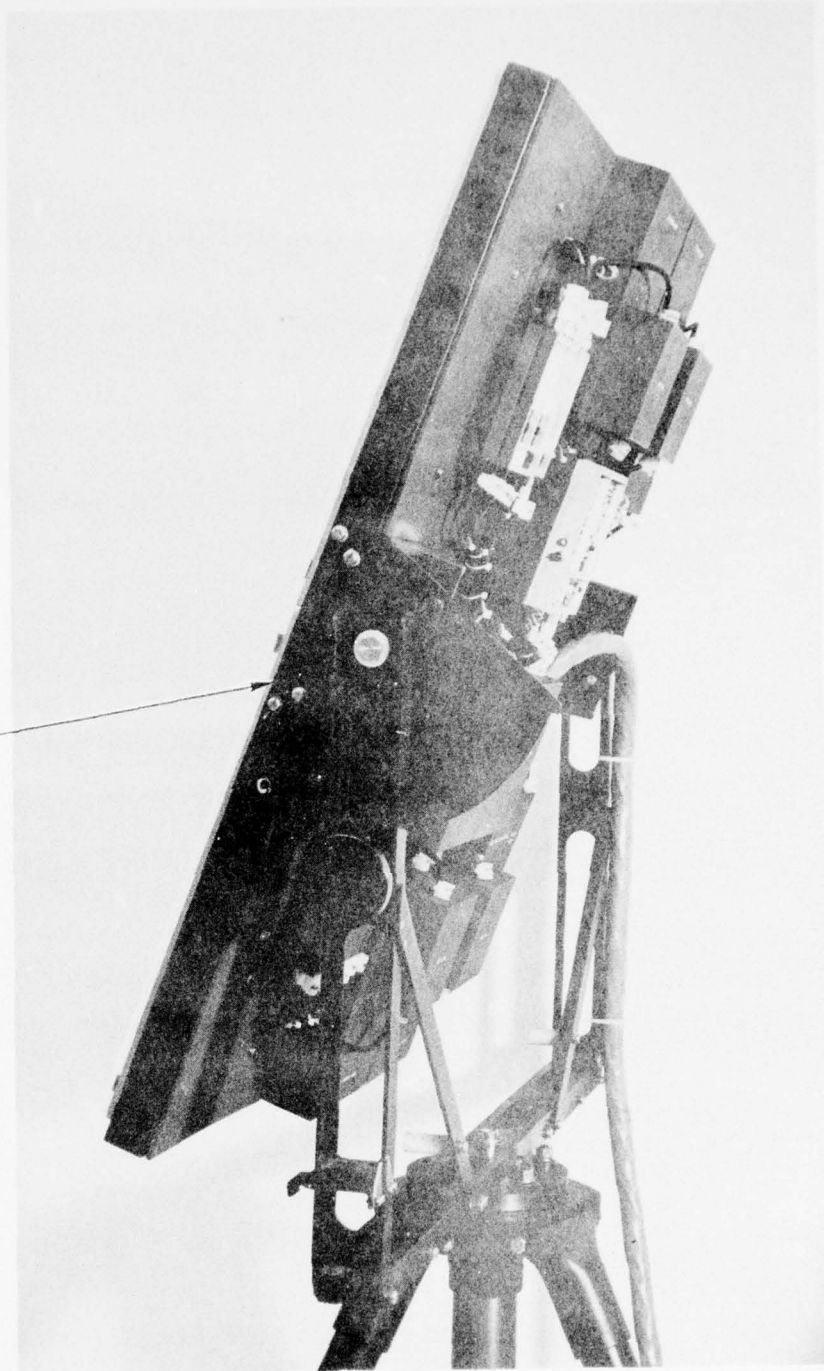

72-0974

Figure 2.0-1. Four-Aperture Phased-Array Antenna

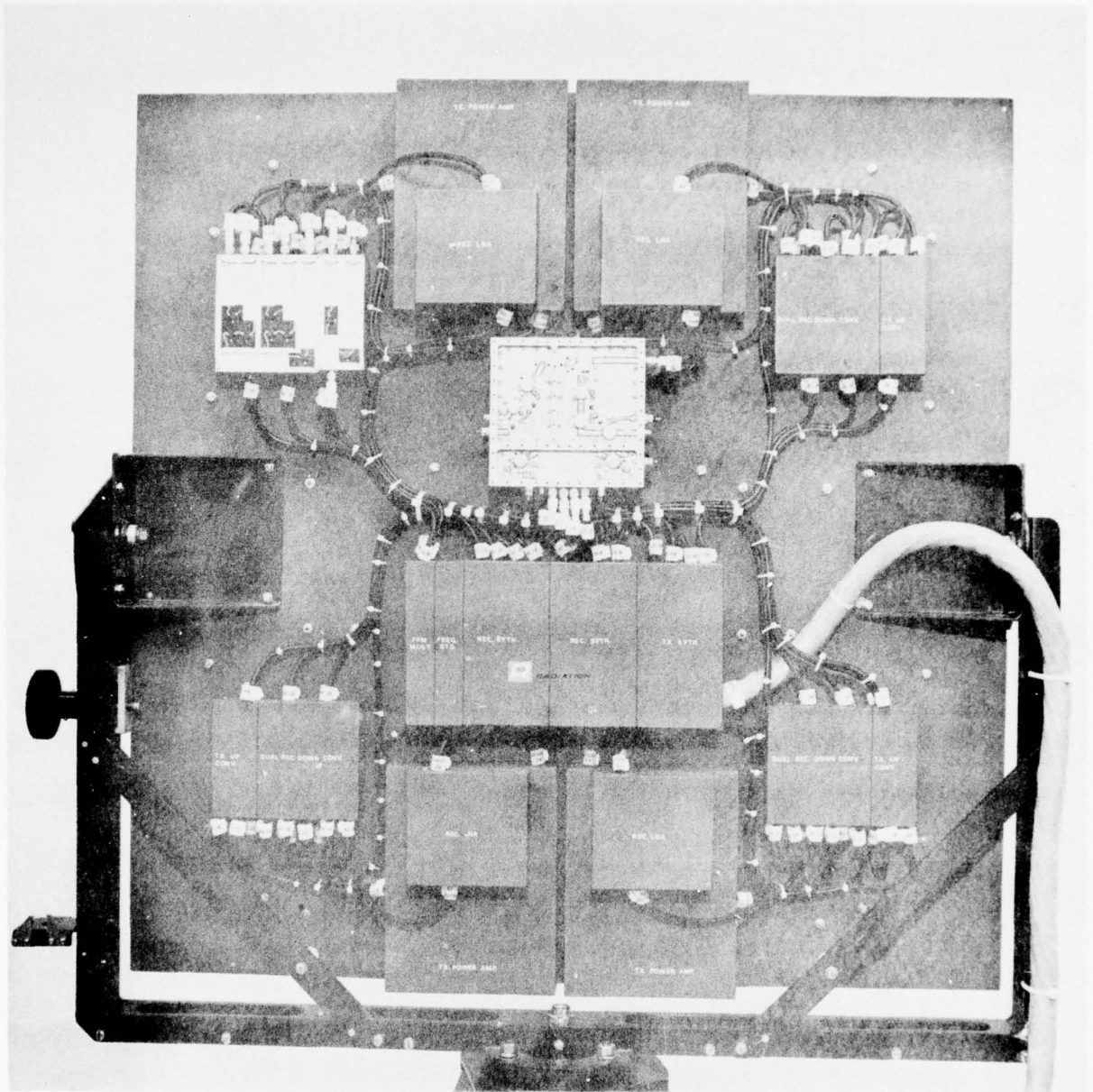

72-0977

Figure 2.0-2. Rear View of Antenna

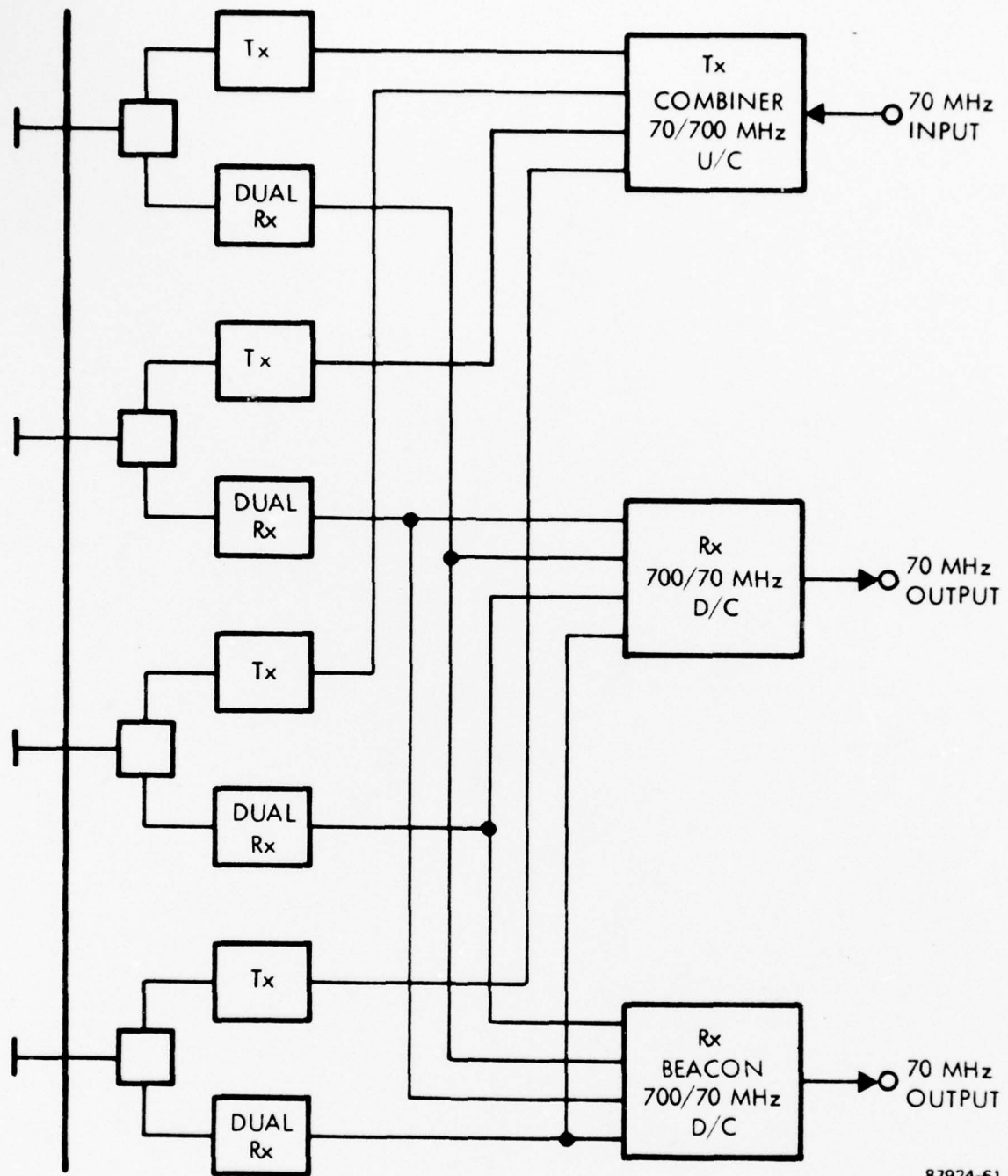

87924-61

Figure 2.0-3. Multiple Aperture Satellite Communications Terminal RF Unit

The initial baseline system was designed to utilize the high-gain antenna of the satellite. However, the earth-coverage antenna could be used if the link gains and margins were to be revised.

Using a single-aperture parabolic dish, an antenna gain of 45 dB is available, which provides the link with 13 dB more gain than is available with the four-aperture phased array unit. Additional transmitter output can also be provided by adding a power amplifier. Thus, a single-aperture configuration can easily more than compensate for the 16 dB loss incurred by having to use the satellite earth-coverage antennas.

A program redirection was established to maximize the developmental benefits already accrued on this program. A single-aperture system was configured for evaluation of the developed hardware, as shown in Figure 2.0-4.

The program redirection included the packaging of the up- and down-converter functions in rack-mounted drawers. These 3-1/2 inch drawers were to be totally self-sufficient and operate from the AC line. Figure 2.0-5 shows these converter drawers. Tables 2.0-1 and 2.0-2 summarize their performance.

Also as a part of the program redirection, a complete low-capacity terminal was put together and demonstrated.<sup>1</sup> The receiver-transmitter elements included (see Figure 2.0-4) a low-noise amplifier, a solid-state driver and a solid-state power amplifier, as well as the up- and downconverter and associated self-contained local oscillators. The low-noise amplifier and driver were supplied by Radiation under this contract, and the power amplifier was loaned by USASATCOMA.

The low-noise amplifier is a tunnel diode amplifier purchased from International Microwave Corporation, Model ACP-7500-30. Its characteristics are listed in Table 2.0-3 below.

The following paragraphs outline the detailed development of the subsystem elements of the down-converter and up-converter.

---

<sup>1</sup>G. P. Petrick and C. M. Abrahamson, "Economic Considerations for Low Capacity SHF Satellite Communications Earth Terminals," to be presented at AIAA 5th Communications Satellite Systems Conference, April 1974.

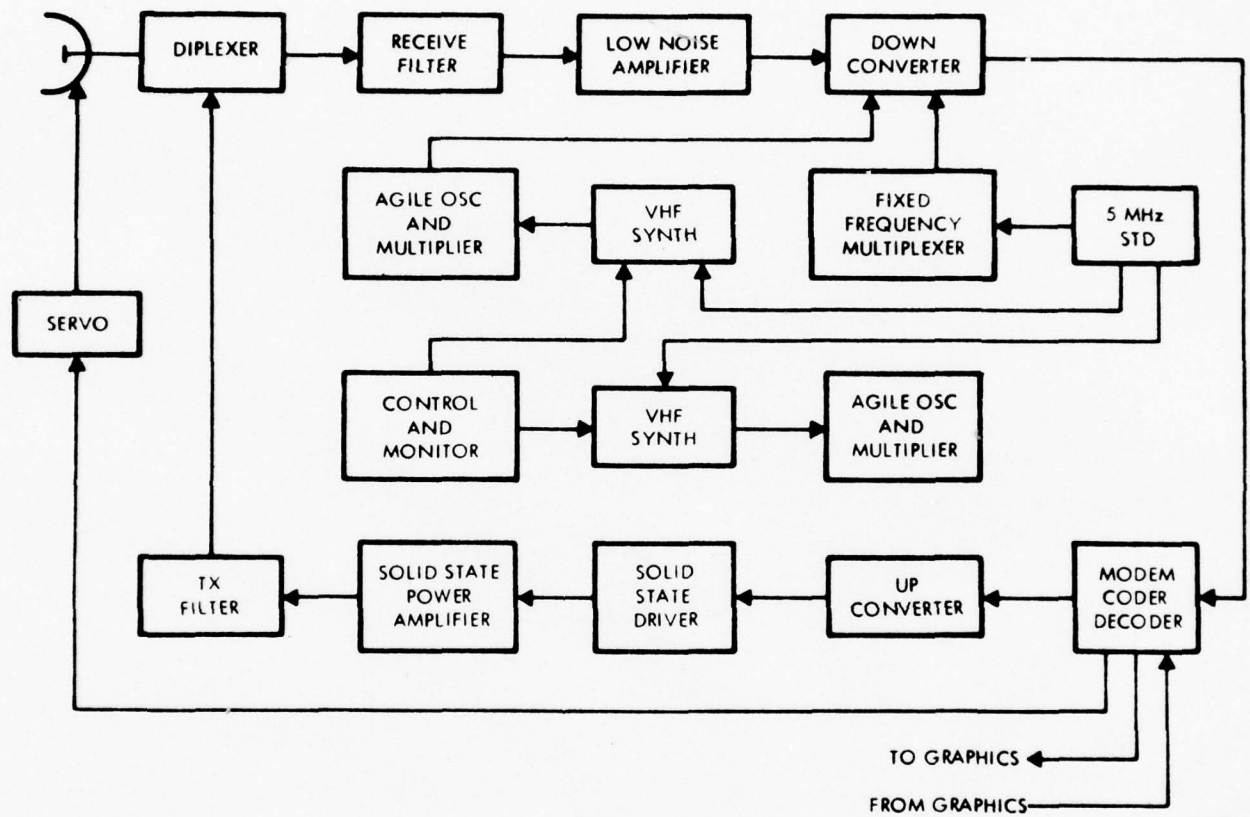

Figure 2.0-4. Single-Aperture Baseline System

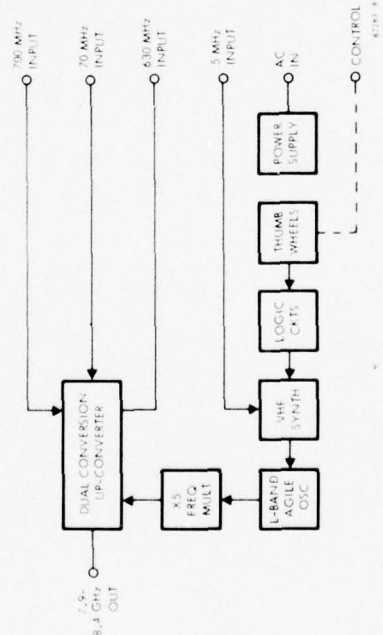
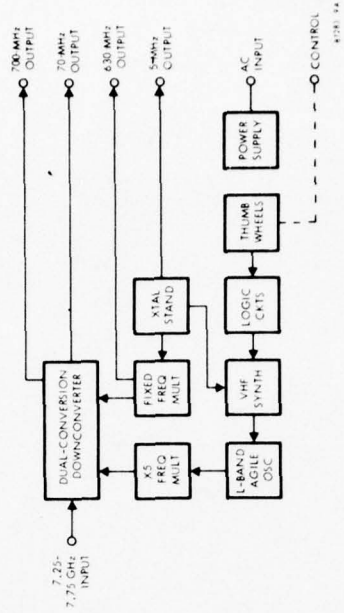
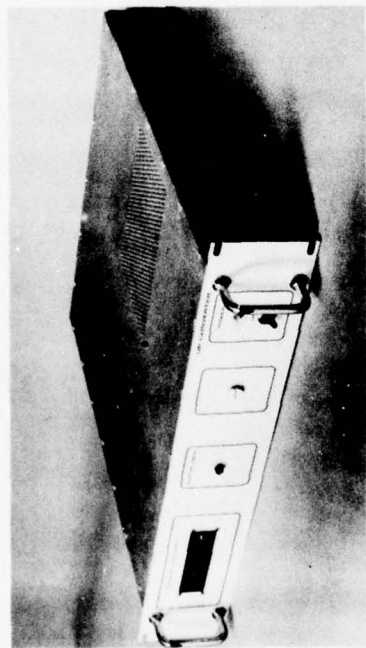
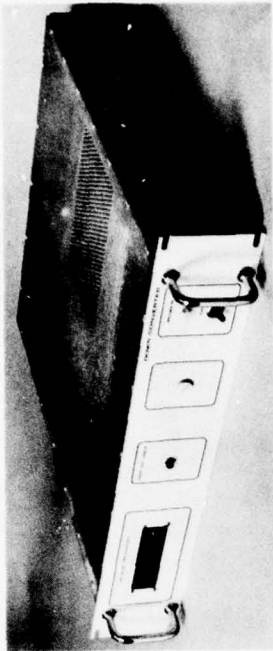

Figure 2.0-5 Solid-State Up- and Down-Converters

Table 2.0-1. Downconverter Performance

<u>Parameter</u>	<u>Capabilities</u>
Input Frequency:	7250 to 7750 MHz
Input Impedance:	50 ohms
Noise Figure:	15.0 dB
Maximum Signal Input Level:	-40 dBm
First LO Frequency:	6550 to 7050 MHz
First IF Frequency:	700 MHz
Second LO Frequency:	630 MHz
Output Frequency:	70 MHz
Output Impedance:	50 ohms
Output Port VSWR:	1.40:1
Amplitude Ripple:	$\pm 0.5$ dB over 40 MHz
Group Delay:	$\pm 2.5$ ns over 40 MHz
Output Signal Level:	-5 dBm
Gain:	35 dB

Table 2.0-2. Upconverter Performance

<u>Parameter</u>	<u>Capabilities</u>
Input Frequency:	70 MHz
Input Impedance:	50 ohms
Input VSWR:	1.10:1
Input Power, Nominal:	0 dBm
First LO Frequency:	630 MHz
First IF Frequency:	700 MHz
Second LO Frequency:	7200 to 7700 MHz
Output Frequency:	7900 to 8400 MHz
Output Impedance:	50 ohms
Output VSWR:	1.50:1
Amplitude Ripple:	$\pm 0.50$ dB over 40 MHz
Group Delay:	$\pm 3.0$ ns over 40 MHz
Output Power:	-10 dBm
Gain	-10 dB

Table 2.0-3. Low-Noise Amplifier Characteristics

Frequency Range:	7.25-7.75 GHz
Bandwidth:	500 MHz minimum
Noise Figure:	4.7 dB maximum, measured with hot/cold load
Gain:	30 dB minimum
Input Compression, 1 dB:	-54 dBm minimum

The driver amplifier is an Impatt diode amplifier, Hughes Model 46615H. Its characteristics are listed in Table 2.0-4 below.

Table 2.0-4. Driver Amplifier Characteristics

Frequency Range:	7.9-8.4 GHz
Power Output:	0.75 W Maximum, 0.5 W nominal
Gain:	40 dB
Gain Flatness:	-0, +1 dB
Gain Variation over Temperature:	±1 dB
Power Variation over Temperature:	-0, +1 dB
Operating Temperature:	0 to +52°C
Phase Deviation from Linear:	5°/40 MHz 10°/125 MHz

The power amplifier is also an Impatt diode amplifier, developed by Raytheon. It has an output capability of 5 watts.

Using this power amplifier as the transmitter output element, feeding the 45-dB-gain single-aperture dish, gives a 4 dB increase in transmitted power as compared with four aperture-combined 0.5 W outputs. This, along with the 13 dB increase in antenna gain, more than makes up for the 16 dB loss in satellite antenna gain incurred by having to use the earth-coverage antenna.

## 2.1 Combiner Module

The combiner module contains two separate and independent functions, one for receiving and one for transmitting. The receive function is a downconverter which accepts either one or four\* 700 MHz low-level IF inputs and provides high-level outputs at 700 MHz and 70 MHz. The transmit function performs the inverse operation. It accepts an input at either 70 or 700 MHz and provides four separate 700 MHz outputs.

A block diagram with performance budgets of the downconverter is shown in Figure 2.1-1. The 700 MHz IF signal from the X-band downconverter passes through a 4-way combiner to a PIN diode switch. The switch selects either the output of the 4-way combiner or a single-aperture input. The signal is then divided two ways to drive the 40 and 125 MHz bandwidth channels. The 125 MHz channel consists of three wideband 700 MHz amplifiers and a bandpass filter. The 40 MHz channel consists of a 700 MHz wideband amplifier and bandpass filter which feed a double-balanced mixer. The translation frequency of 630 MHz is supplied to the mixer from the fixed-frequency multiplier module. The 70 MHz output of the mixer passes through a lowpass filter, two wideband amplifiers and a second lowpass filter. The 70 MHz signal from the downconverter is passed to an external modem.

The upconverter block diagram and expected performance are shown in Figure 2.1-2. The upconverter accepts either a wideband 700 MHz IF signal or a narrowband 70 MHz IF signal. The wideband input passes through a bandpass filter to one port of a 2-way combiner. The narrowband input feeds a double-balanced mixer whose 630 MHz translation frequency from the fixed-frequency multiplier module is filtered with a highpass filter. The 700 MHz output of the mixer then passes through a bandpass filter and highpass filter to the other input port of the 2-way combiner. The combiner output is then amplified by four wideband 700 MHz amplifiers and divided into four coherent outputs to feed X-band converters.

The individual circuits are described in the following paragraphs.

---

\*The four-input provision at 700 MHz (and the transmit four-output provision) result from the original multiple-aperture requirement, which was subsequently deleted.



70/700 MHz UPCONVERTER (SUBMODULE ASA3)  
 (P/O COMBINER MODULE A5)

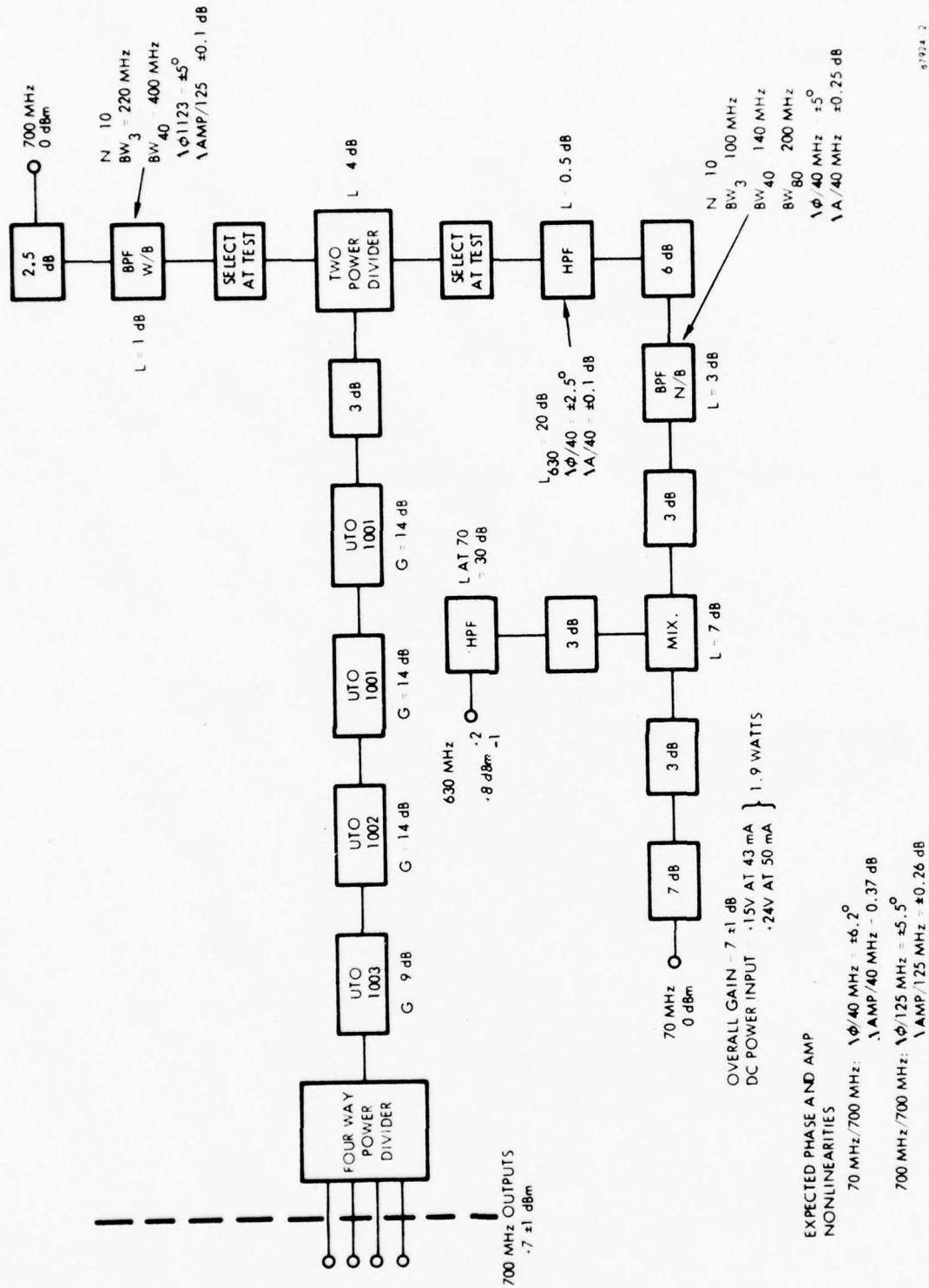

91924 2

Figure 2.1-2. Upconverter Block Diagram

## 2.1.1 Downconverter

### 2.1.1.1 Downconverter 4-Way Combiner/2-Way Divider

The 4-way combiner/2-way divider selects either four coherent 700 MHz input signals or one single-aperture input signal to drive two combiner downconverter channel simultaneously. Figure 2.1-3 shows the basic requirement of the combiner/divider module.

A Wilkinson-type divider was chosen for the combining and dividing functions because of its small size and weight, good isolation between ports, and low cost. It also lends itself readily to microstrip design.

Figure 2.1-4 is a schematic diagram of the combiner/divider module. The combiner section consists of a pair of binary combiners driving a third binary combiner. A pair of series-connected PIN diodes functions as a SPDT RF switch to allow selection of either the single-aperture input or the combiner output to drive the divider. A binary Wilkinson circuit is also employed as the divider.

The resulting performance is as follows:

#### Insertion Loss:

Single-aperture input to each of two outputs: 4.3 dB maximum

Each of four input ports to each of two output ports: 11.5 dB maximum

VSWR, All Ports: 1.5 maximum

#### Isolation Between Ports:

Single-aperture input to multiple-aperture input: 36 dB

Multiple-aperture input to single-aperture input: 26 dB

Multiple-aperture input to multiple-aperture input: 18 dB minimum

Output to output: 18 dB

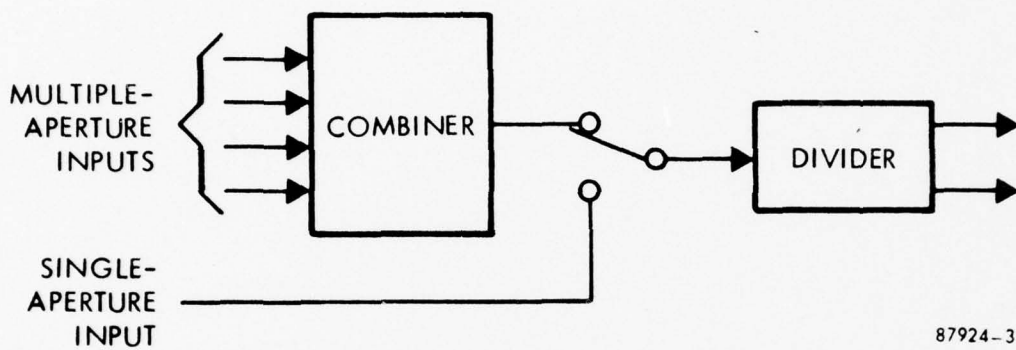

87924-3

Figure 2.1-3. Combiner/Divider Module Block Diagram

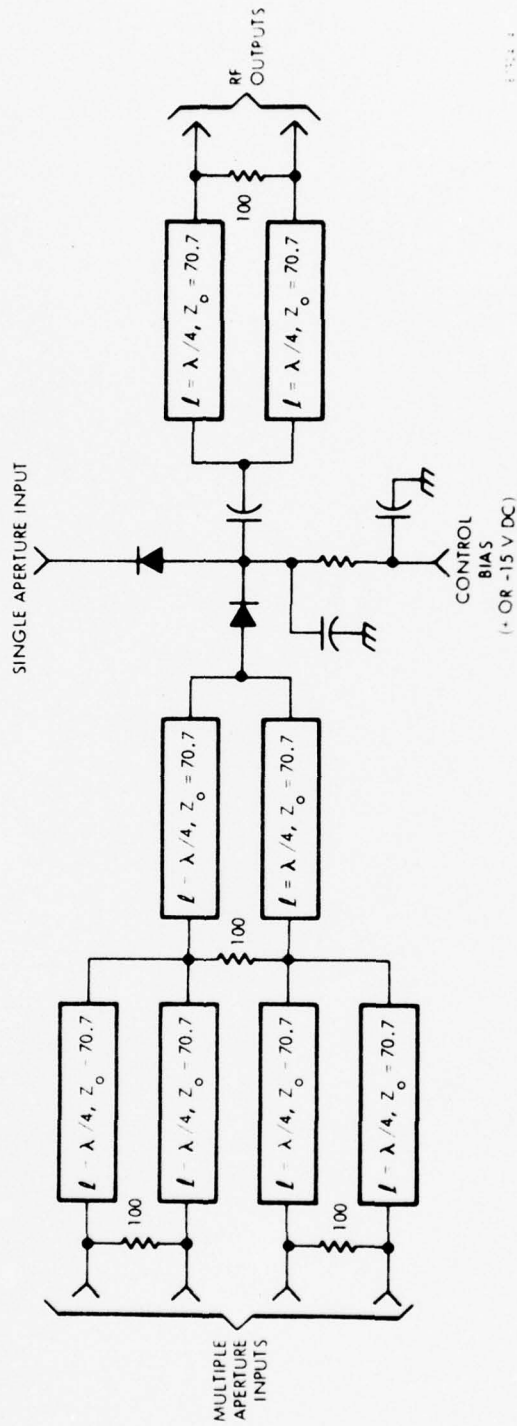

Figure 2.1-4. Combiner/Divider Module Schematic Diagram

### 2.1.1.2 Wideband Amplifiers

In order to obtain the proper drive levels at the output of the combiner down-converter, it is necessary to provide gain within the converter. Wideband amplifiers are used to maintain a flat group delay through the converter.

Amplifiers are placed in the following locations to obtain the proper gain distribution.

1. Outputs of the 2-way divider (700 MHz)
2. Output of the wideband interdigital filter (700 MHz)
3. Output of the local oscillator reject filter (70 MHz)

Avantek was chosen to supply all amplifiers in their UTO-series for the following reasons:

1. Bandwidths of several octaves
2. Thin-film construction
3. Small size

Referring to the block diagram of Figure 2.1-1, it will be seen that several different types of UTO-series amplifiers are employed. Each type was selected for the optimum combination of gain, dynamic range, noise figure and frequency coverage for its application.

### 2.1.1.3 Wideband (125 MHz) and Narrowband (40 MHz) 700 MHz Bandpass Filters

Filtering at the 700 MHz IF is required to reject undesired signals outside the information bandwidth before further signal processing. The information bandwidth was specified to be 125 MHz for the 700 MHz downconverter output and 40 MHz for the 70 MHz output. As well as rejecting out-of-band signals, however, this filtering must also be virtually "transparent" - that is, have flat amplitude and delay response - over the information bandwidth. Thus, two filters are required, for the two information bandwidths, each of which is critical both in terms of in-band characteristics (amplitude and phase) and out-of-band rejection.

The designs of these two filters were among the most technically challenging aspects of this program. Hence, they are treated in considerable detail in the following paragraphs. Several computer-aided analysis iterations went into the selections of the final designs of both filters in an effort to arrive at the optimum compromise among the various performance characteristics and physical size.

The wideband filter design finally selected is a 10-pole Butterworth (zero ripple) filter with a bandwidth of 250 MHz (35 percent).

A 10-pole design was also selected for the narrowband filter, but with 0.1-dB ripple and a bandwidth of 126 MHz (18 percent).

For best compatibility with the converter design, a stripline interdigital design was selected for both filters.

The stripline filters were designed for 0.125 inch duroid material with a dielectric constant of 2.35. The filters were calculated from the capacitance matrix for those particular filter parameters. These capacitance values were then normalized for duroid material, and the spacing between elements determined with design curves. The width of each element was then determined. The lengths of the elements are 0.25 wavelength adjusted for duroid material, and both filters were calculated in the same manner.

For example, the wideband filter was designed as follows:

$$f_0 = 700 \text{ MHz}$$

$$\text{BW} = 250 \text{ MHz (35 percent)}$$

$$\text{Ripple} = 0.0 \text{ dB}$$

Capacitance Matrix:

K	Normalized C(K, K+1)	K	Normalized C(K)
1 & 9	2.79602146	1 & 10	3.99469662
2 & 8	1.02351284	2 & 9	1.68448544
3 & 7	0.73060465	3 & 8	2.72461128
4 & 6	0.61819220	4 & 7	2.98018932
5	0.58721030	5 & 6	3.07984447

$$\epsilon = 2.35$$

$$\sqrt{\epsilon} = 1.533 \text{ (for normalization in duroid)}$$

Normalized Capacitance:

K	Capacity in Duroid $\Delta C/\epsilon$	(Spacing) S/b	$C'f_e/\epsilon$	K	$\Delta C/\epsilon$
1 & 9	1.732	.055	.053	1 & 10	2.480
2 & 8	.635	.255	.210	2 & 9	1.045
3 & 7	.4535	.360	.270	3 & 8	1.767
4 & 6	.383	.410	.295	4 & 7	1.852
5	.374	.415	.300	5 & 6	1.911

Spacings between elements become:

$$S(1 \& 9) = .01376$$

$$S(2 \& 8) = .0638$$

$$S(3 \text{ \& } 7) = .0901$$

$$S(4 \text{ \& } 6) = .1025$$

$$S(5) = .1037$$

Widths of elements are calculated by:

$$W_k/b = 1/2(1-t/b) \left[ 1/2(C'(K)/\epsilon) - C'f_e(K-1,K)/\epsilon - C'f_e(K+1,K)/\epsilon \right]$$

$$W_0 = 0.08986$$

$$W_1 = 0.03207$$

$$W_2 = 0.05049$$

$$W_3 = 0.04462$$

$$W_4 = 0.04456$$

Figures 2.1-5 and 2.1-6 show the layouts of the wideband and narrowband filters, respectively.

Initial test results indicated that the response was centered too high in frequency in both filters. Each element was lengthened by 0.105 inch. Figures 2.1-7 and 2.1-8 show the wideband filter amplitude response and phase deviation from linear after modification. Figures 2.1-9 and 2.1-10 show the narrowband filter amplitude response and deviation from linear phase.

#### 2.1.1.4 Double-Balanced Mixer

In order to convert the 700 MHz input of the converter to a 70 MHz signal required by the demodulator, it is necessary to mix the 700 MHz signal with a local oscillator of 630 MHz. A double-balanced mixer is used because of its relative insensitivity to local oscillator power variations.

The mixer consists of purchased parts kit assembled on an alumina substrate. The kit consists of two transformers and a matched star diode quad, and was purchased from Mini-Circuits Laboratories. The schematic diagram in Figure 2.1-11 depicts the mixer as it is used

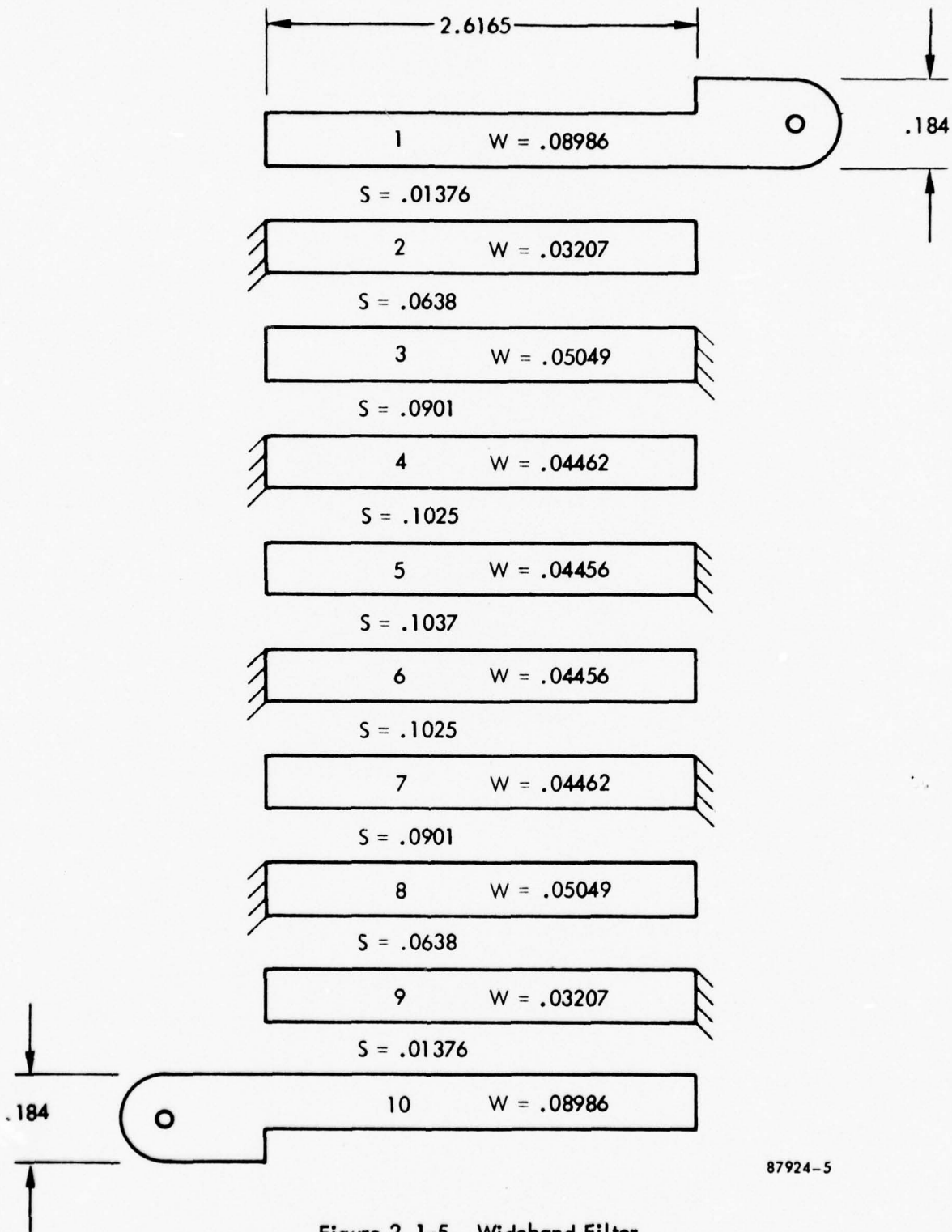

87924-5

Figure 2.1-5. Wideband Filter

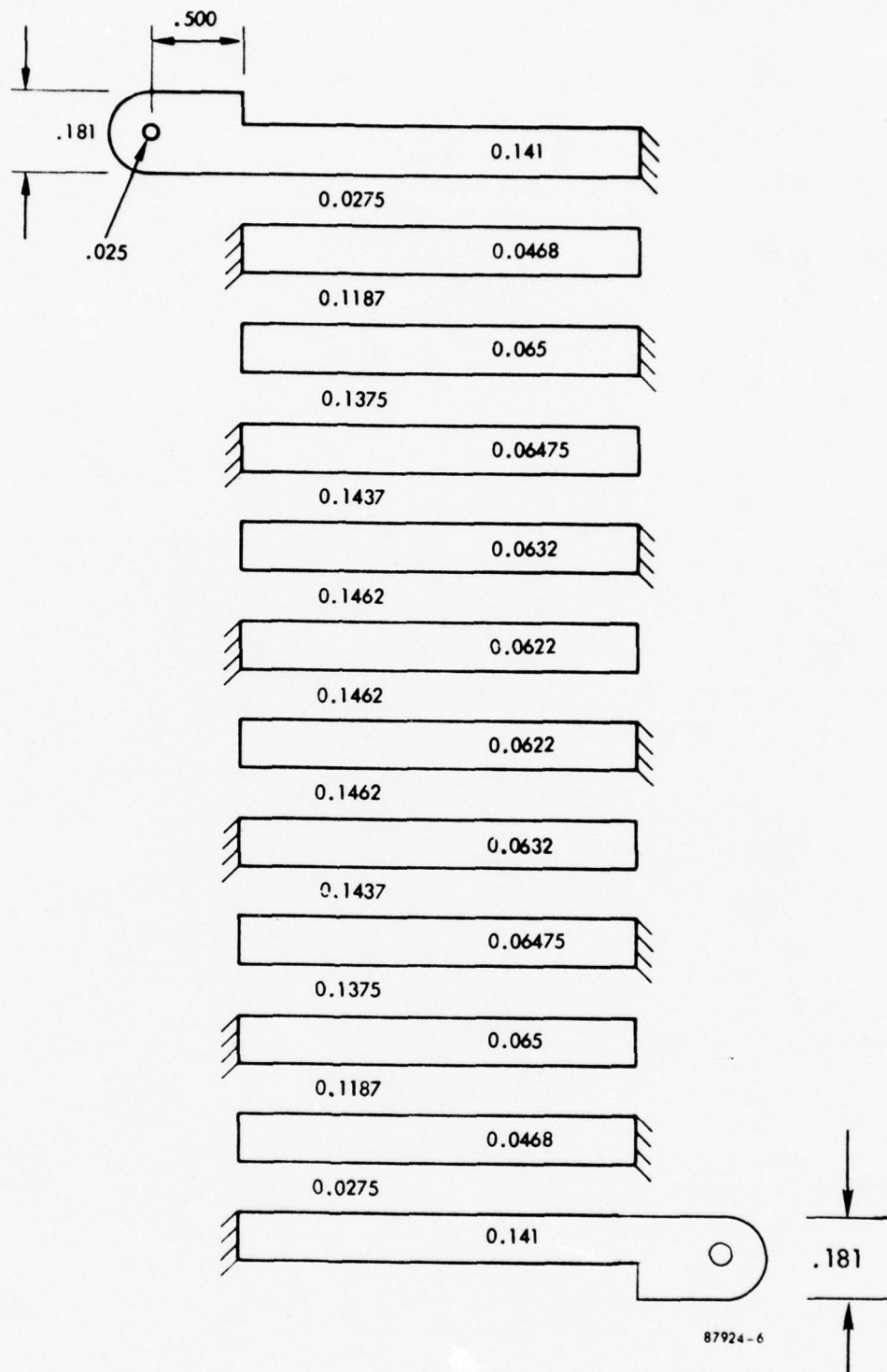
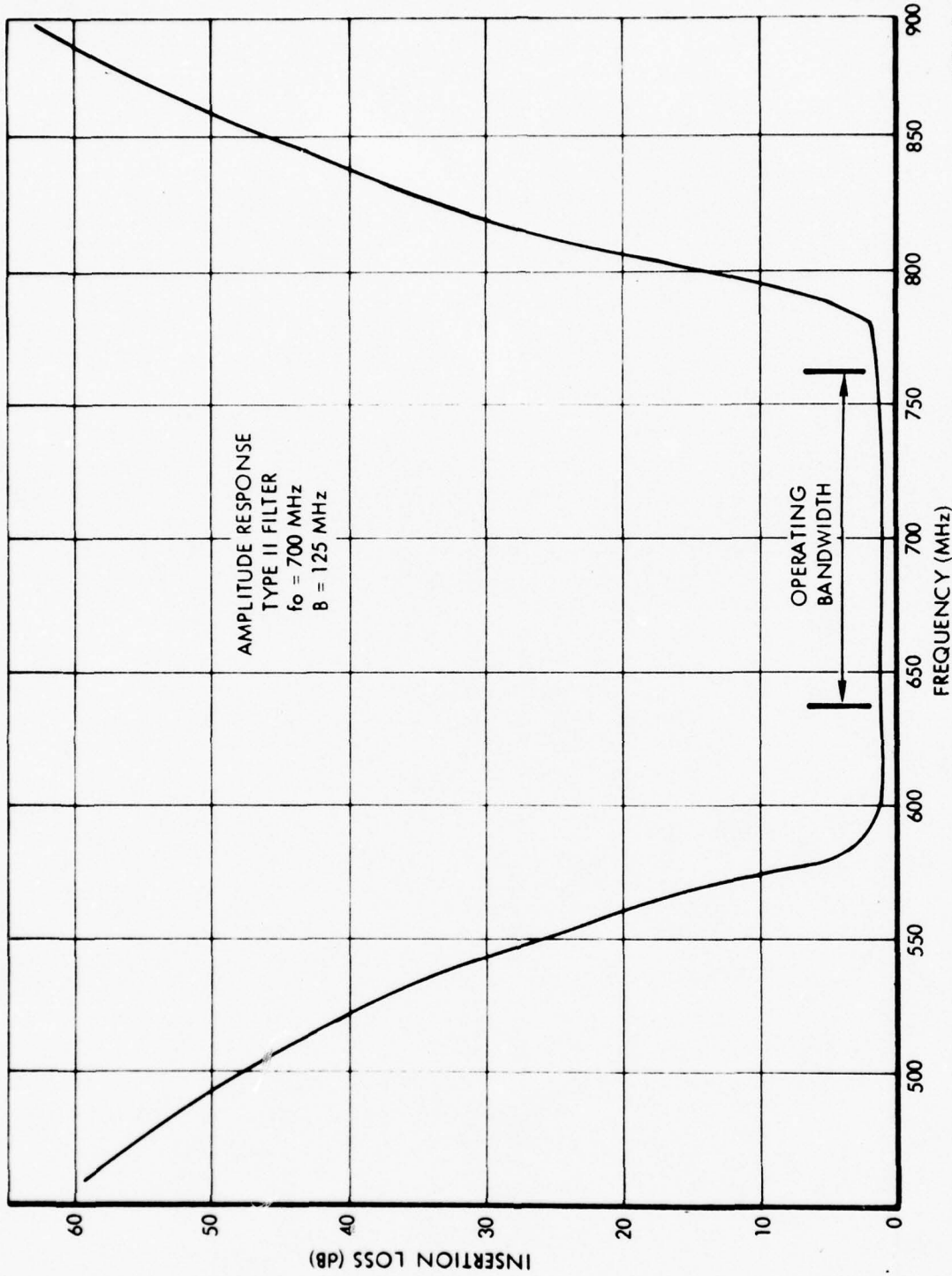
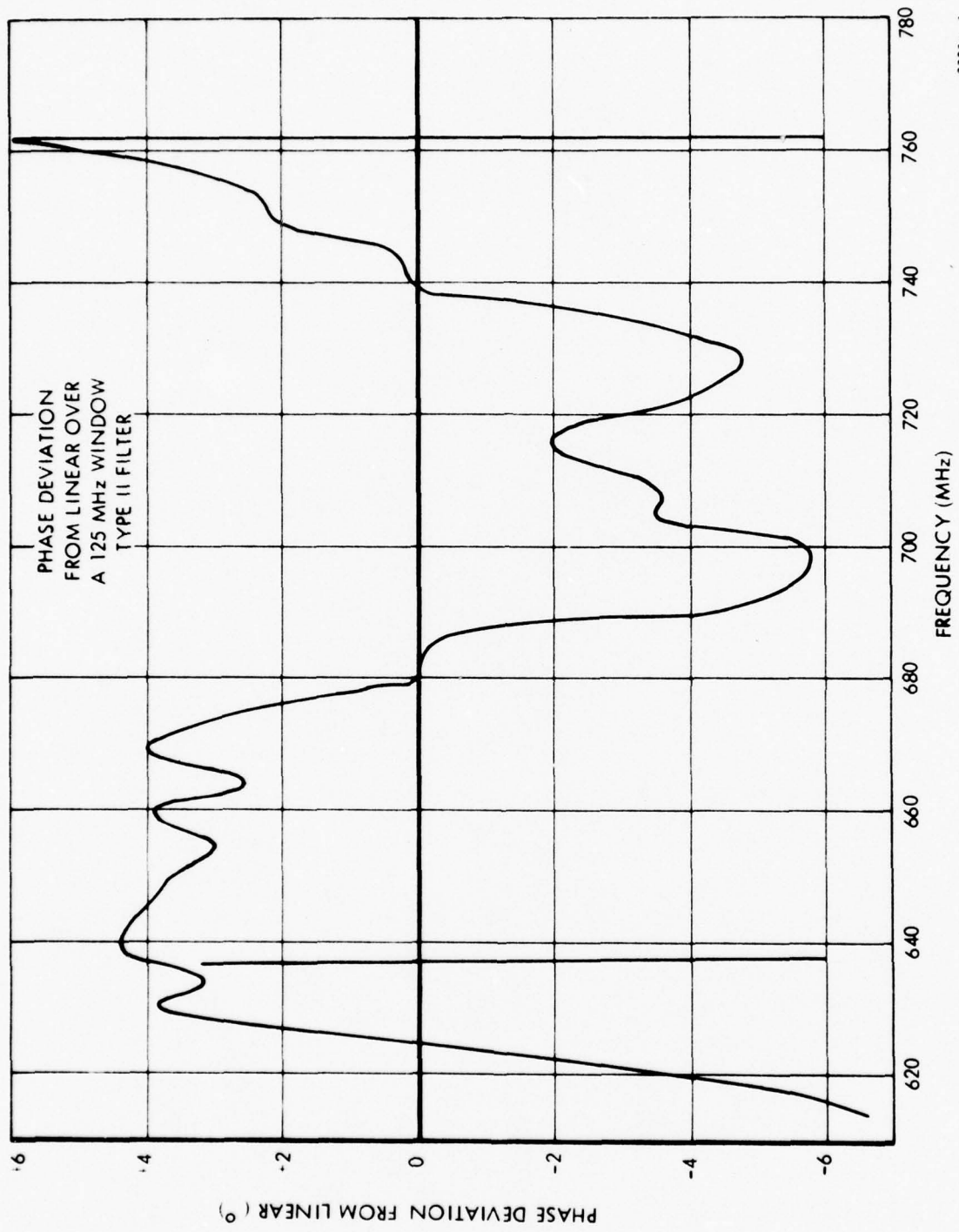

Figure 2.1-6. Narrowband Filter



87924-7

Figure 2.1-7. Wideband Filter Amplitude Response



87924-8

Figure 2.1-8. Wideband Filter Phase Deviation

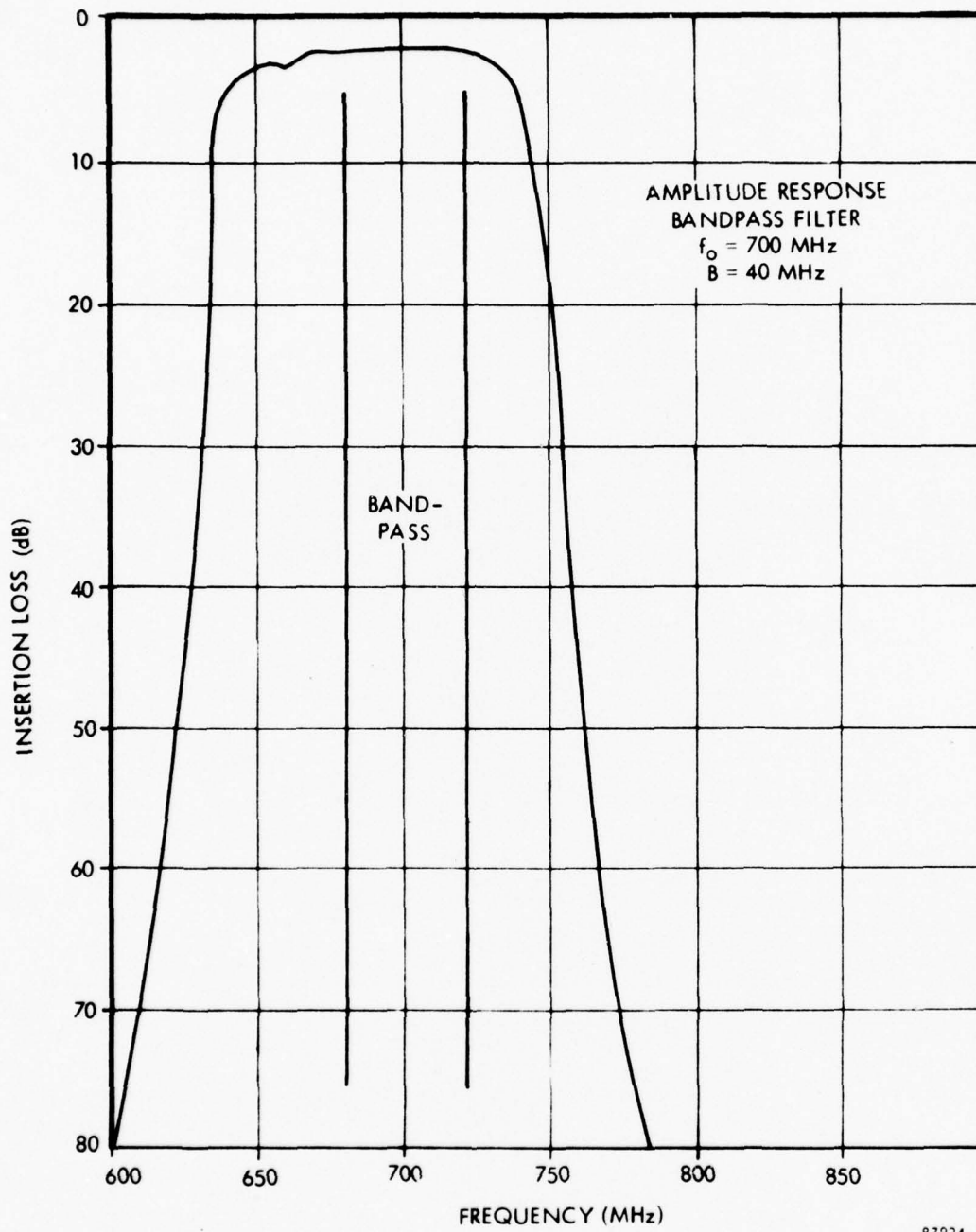

87924-9

Figure 2.1-9. Narrowband Filter Amplitude Response

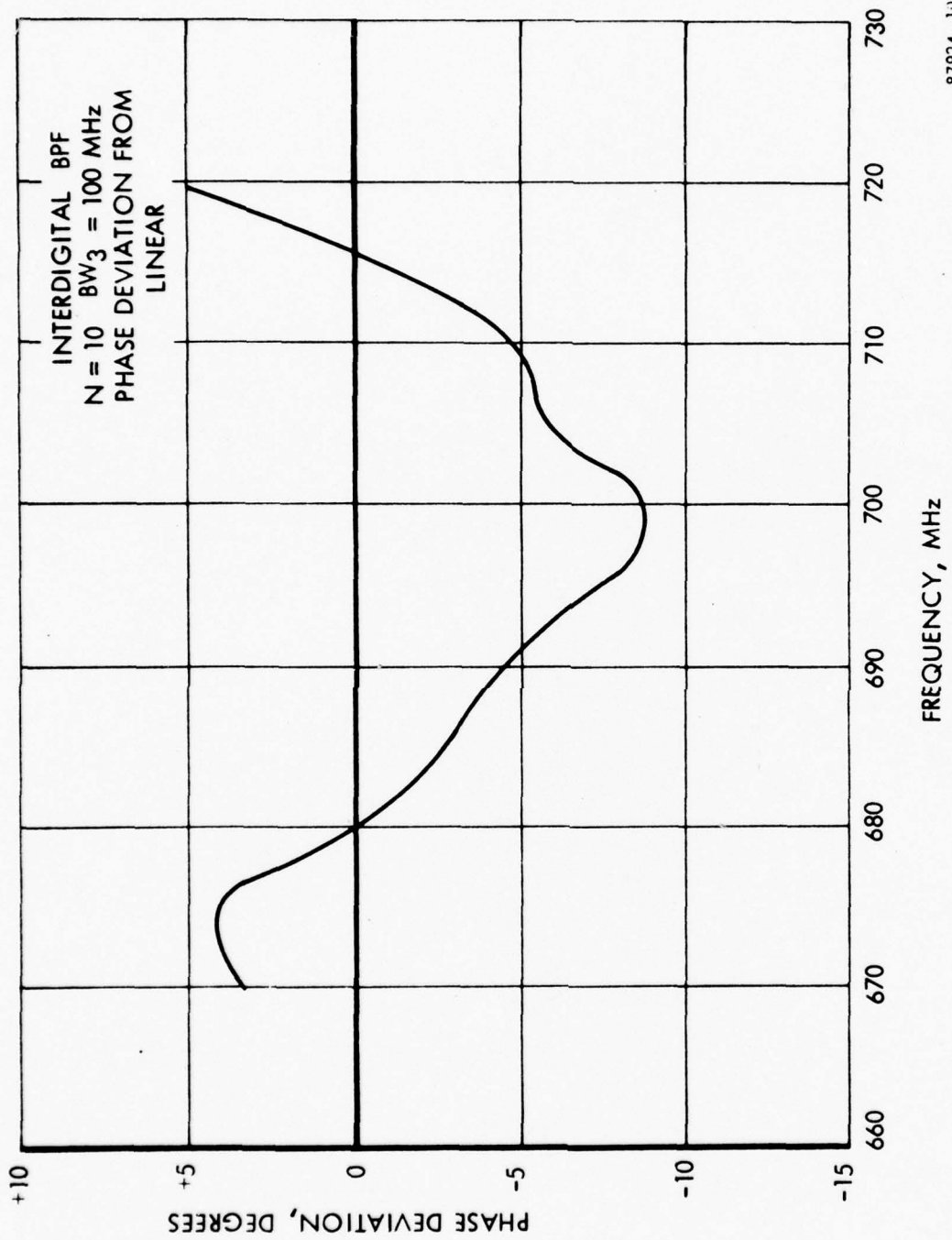

87924-10

Figure 2.1-10. Narrowband Filter Phase Deviation

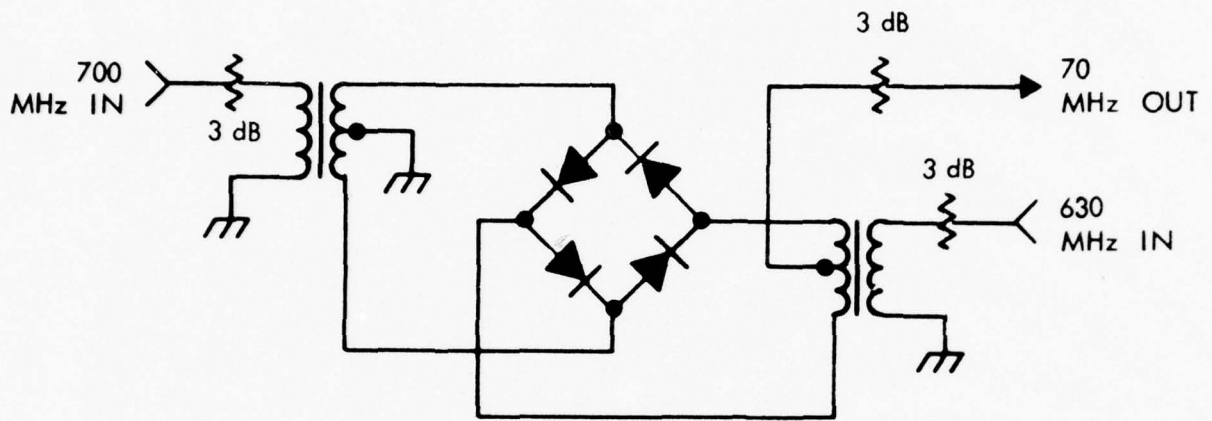

87924-11

Figure 2.1-11. Double Balanced Mixer

in the converter. Attenuator pads of 3 dB were placed at each port for improved isolation and VSWR. The mixer was tested for the following parameters and results:

- |                        |               |
|------------------------|---------------|
| 1. Conversion Loss:    | 12 dB nominal |
| 2. RF to IF Isolation: | 25 dB nominal |
| 3. LO to RF Isolation: | 40 dB nominal |

#### 2.1.1.5 Local Oscillator Reject Filter

The local oscillator signal leakage is nominally 10 dB below the 70 MHz signal at the IF output port of the mixer. It is necessary to greatly attenuate this 630 MHz leakage without disturbing the 40 MHz information band around 70 MHz.

It was decided to place a lowpass filter in the 70 MHz signal path. The design selected is a 4-pole, 0.5-dB ripple filter with a bandwidth of 150 MHz. A lumped-constant configuration was used. Figures 2.1-12 and 2.1-13 show the amplitude and phase response of the filter.

#### 2.1.1.6 Harmonic Reject Filter

The 70 MHz amplifiers produce harmonics of measurable levels out to the fifth harmonic. It is necessary to filter these frequencies without disturbing the information band around 70 MHz.

The close proximity of the second and third harmonic frequencies to the information band makes a standard "all-pole" filter design unrealistic. The number of poles that would be required is unacceptable to achieve the attenuation rolloff required. Therefore, a 7-pole elliptic function filter was chosen to achieve the necessary rolloff of the filter.

The filter was originally designed for a break frequency of 100 MHz. Although the amplitude flatness was  $\pm 0.15$  dB, the phase deviated from linear by more than  $18^\circ$  over the information band. To obtain an adequate phase response from such a filter, it was necessary to move the break frequency to 180 MHz.

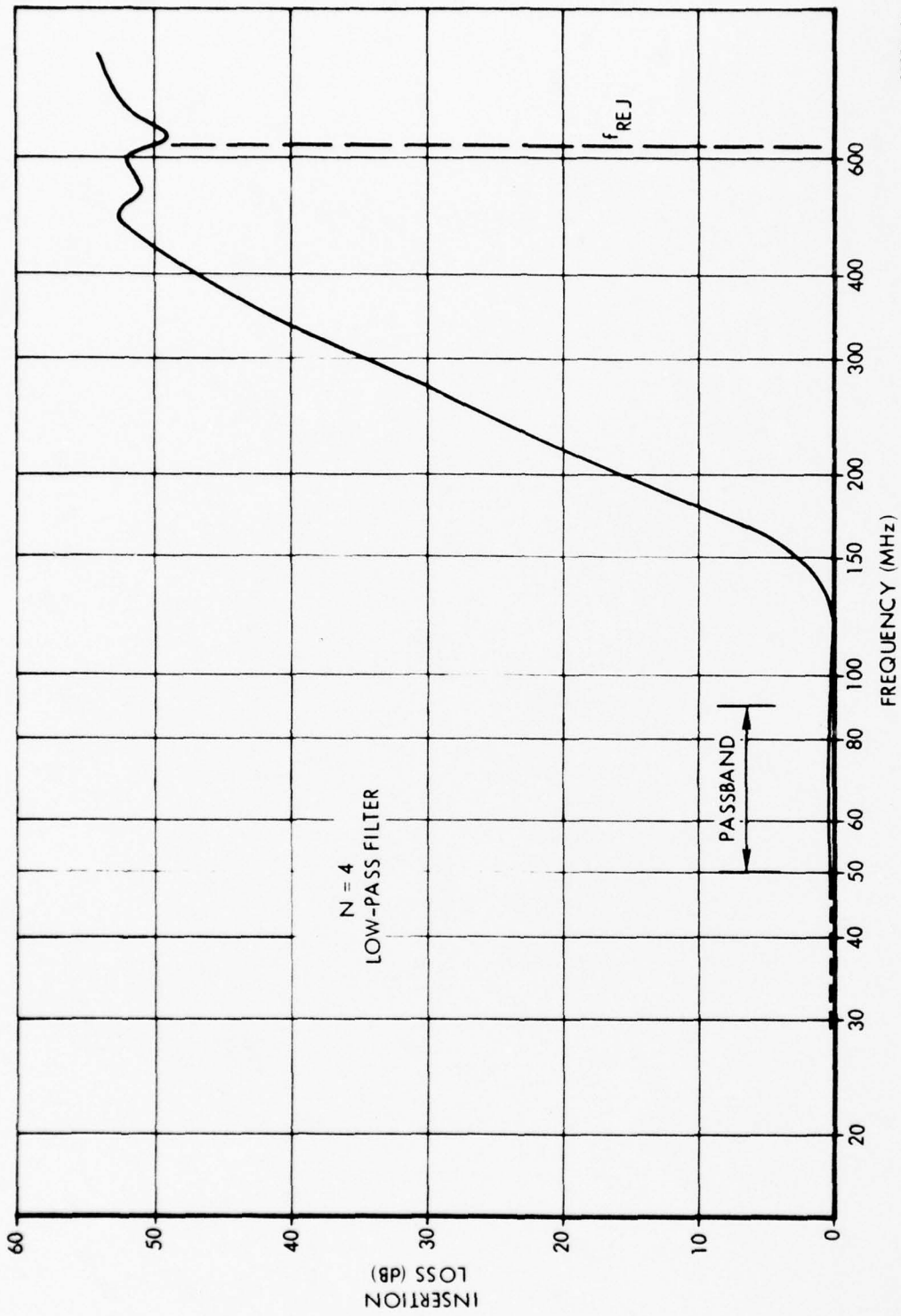

87924-12

Figure 2.1-12. Local Oscillator Reject Filter Amplitude Response

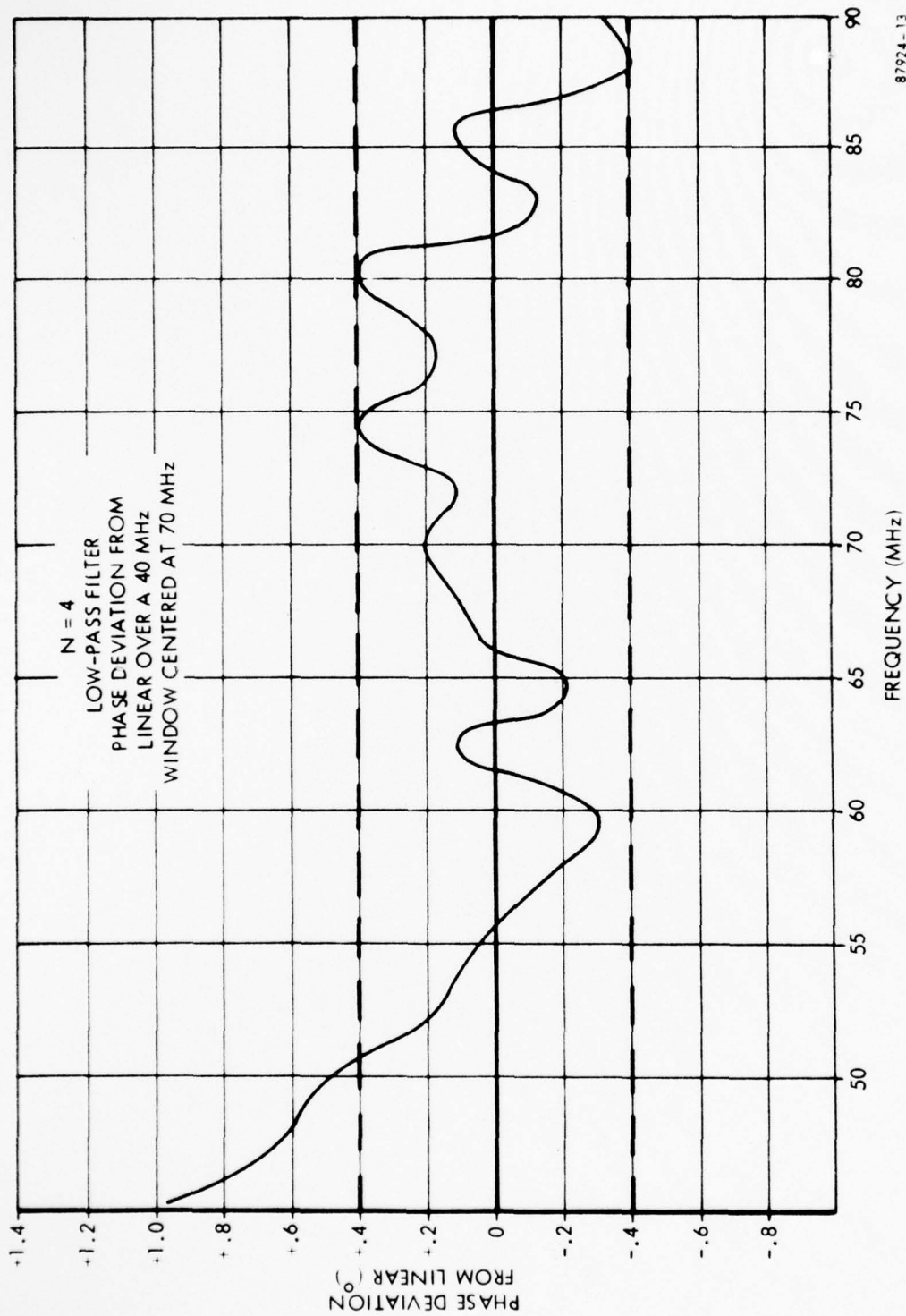

87924-13

Figure 2.1-13. Local Oscillator Filter Phase Response

The filter was designed using elliptic function filter tables for a 7-pole, 0.25 dB ripple, and  $68^\circ$  modular angle filter.

With a break frequency of 180 MHz, phase deviation was less than  $\pm 1.0^\circ$  and amplitude varied less than  $\pm 0.25$  dB over the information bandwidth. The second harmonic was, of course, not attenuated. Figures 2.1-14 and 2.1-15 show the amplitude and phase responses of the filter.

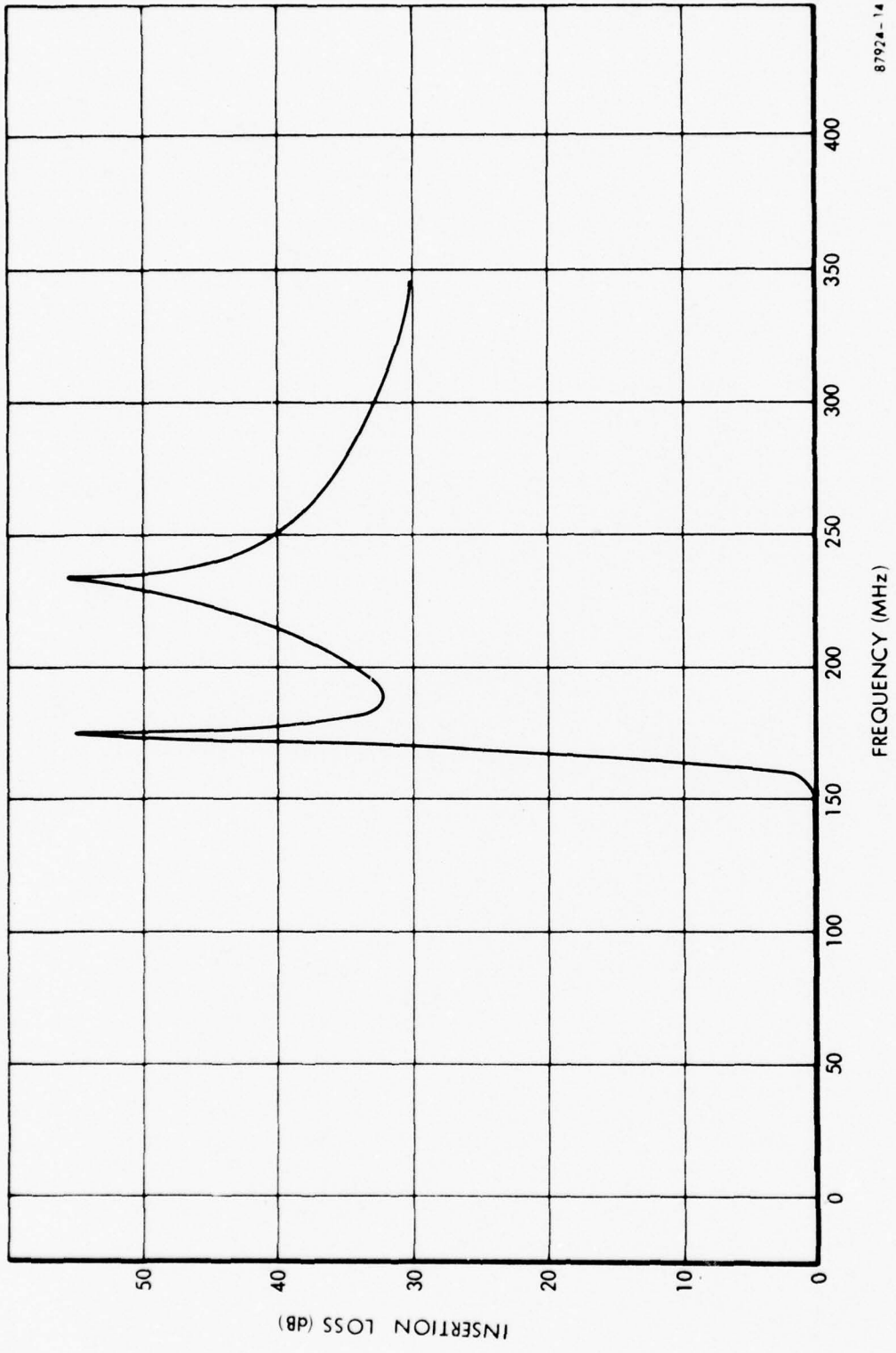

87924-14

Figure 2.1-14. Harmonic Reject Filter Amplitude Response

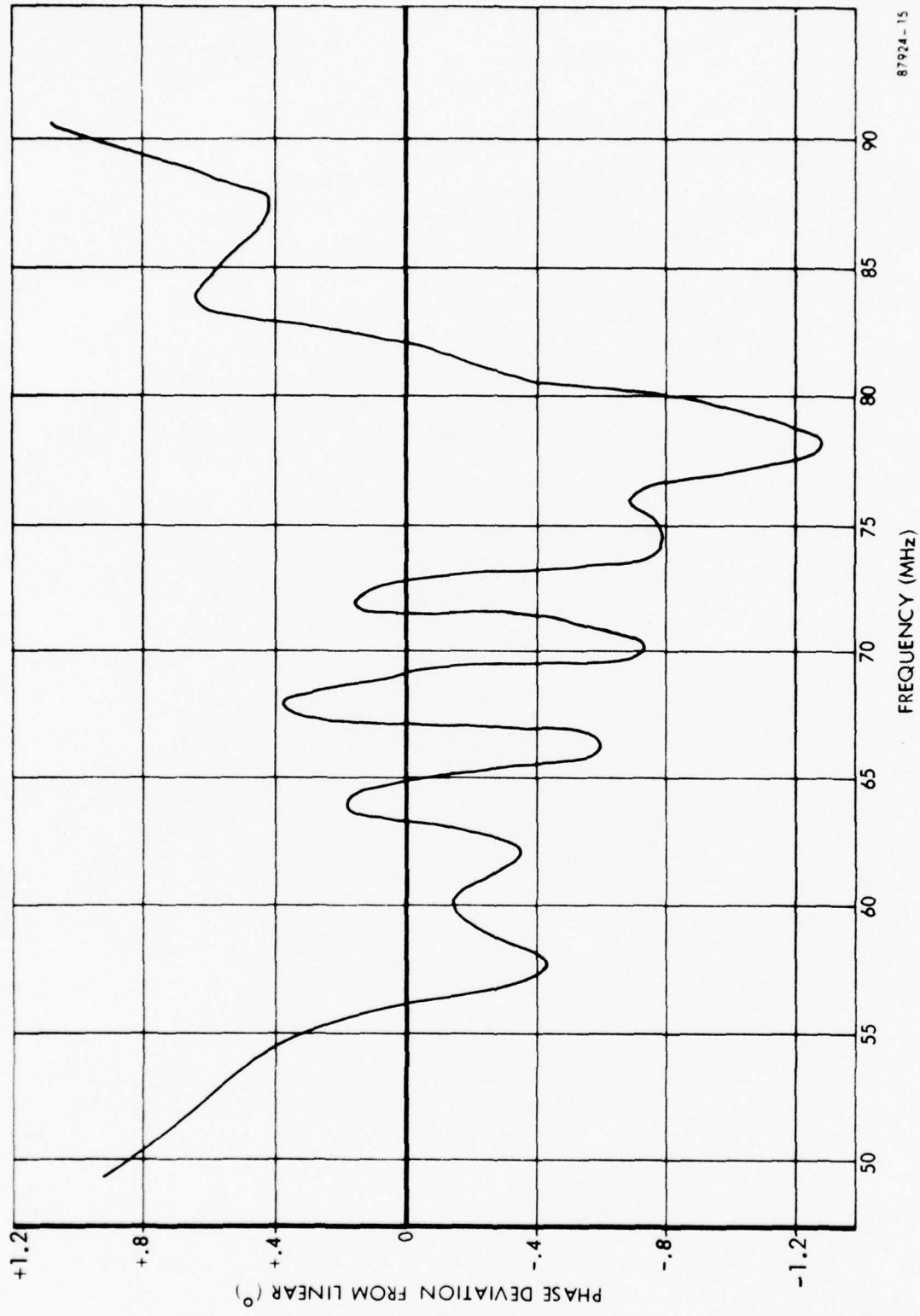

87924-15

Figure 2.1-15. Harmonic Reject Filter Phase Response

## 2.1.2 Upconverter

### 2.1.2.1 Wideband and Narrowband 700 MHz Filters

In the upconverter as in the downconverter, it is necessary to band-limit the 700 MHz intermediate frequency signal to eliminate undesired signals generated in the modulator and 70/700 MHz mixer.

Because of similar requirements demanded of the two filters, the upconverter filters are identical to those used in the downconverter. Figures 2.1-16 and 2.1-17 show the amplitude response of the wideband and narrowband filters, respectively.

### 2.1.2.2 Double-Balanced Mixer

To upconvert the 70 MHz modulator signal to 700 MHz, it is necessary to employ the use of a mixer and a local oscillator signal whose frequency is 630 MHz.

The mixer design is identical to that in the downconverter (Paragraph 2.1.1.4). The 70 MHz is injected into the IF port, 630 MHz into the LO port, and 700 MHz taken from the RF port. Data taken for the mixer in this configuration are shown below:

Conversion Loss:	14 dB
LO to RF Isolation:	35 dB
RF to IF Isolation:	30 dB
IF to LO Isolation:	22 dB

These measurements include the 3-dB attenuators placed at each port.

### 2.1.2.3 IF Reject Filter

It was determined that it is possible to inject a signal at 70 MHz into the upconverter and, through a leakage path, receive the same 70 MHz signal at the output of the downconverter with the converter inputs disconnected. The leakage path is shown in Figure 2.1-18.

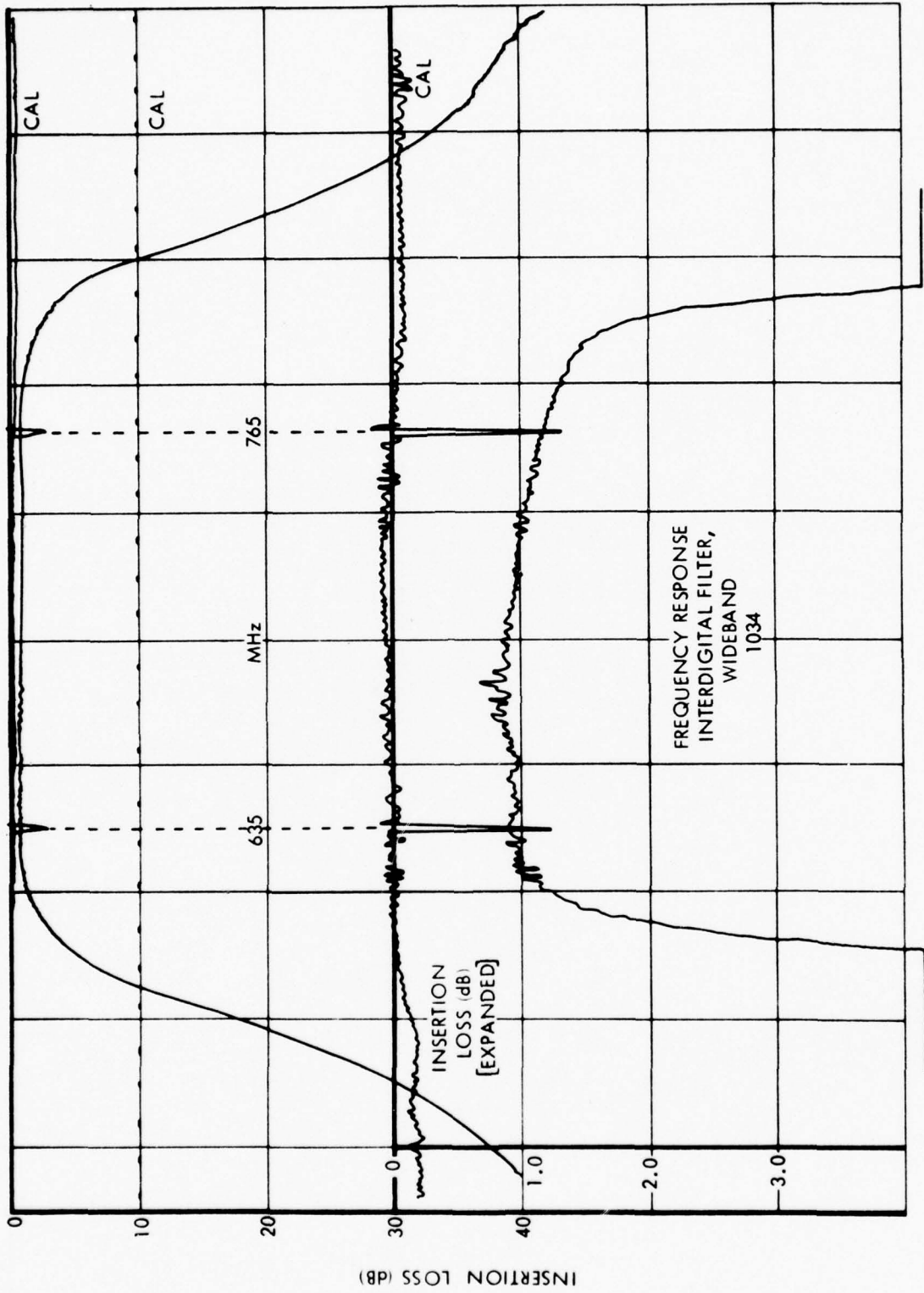

87924-16

Figure 2.1-16. Upconverter Wideband Filter Amplitude Response

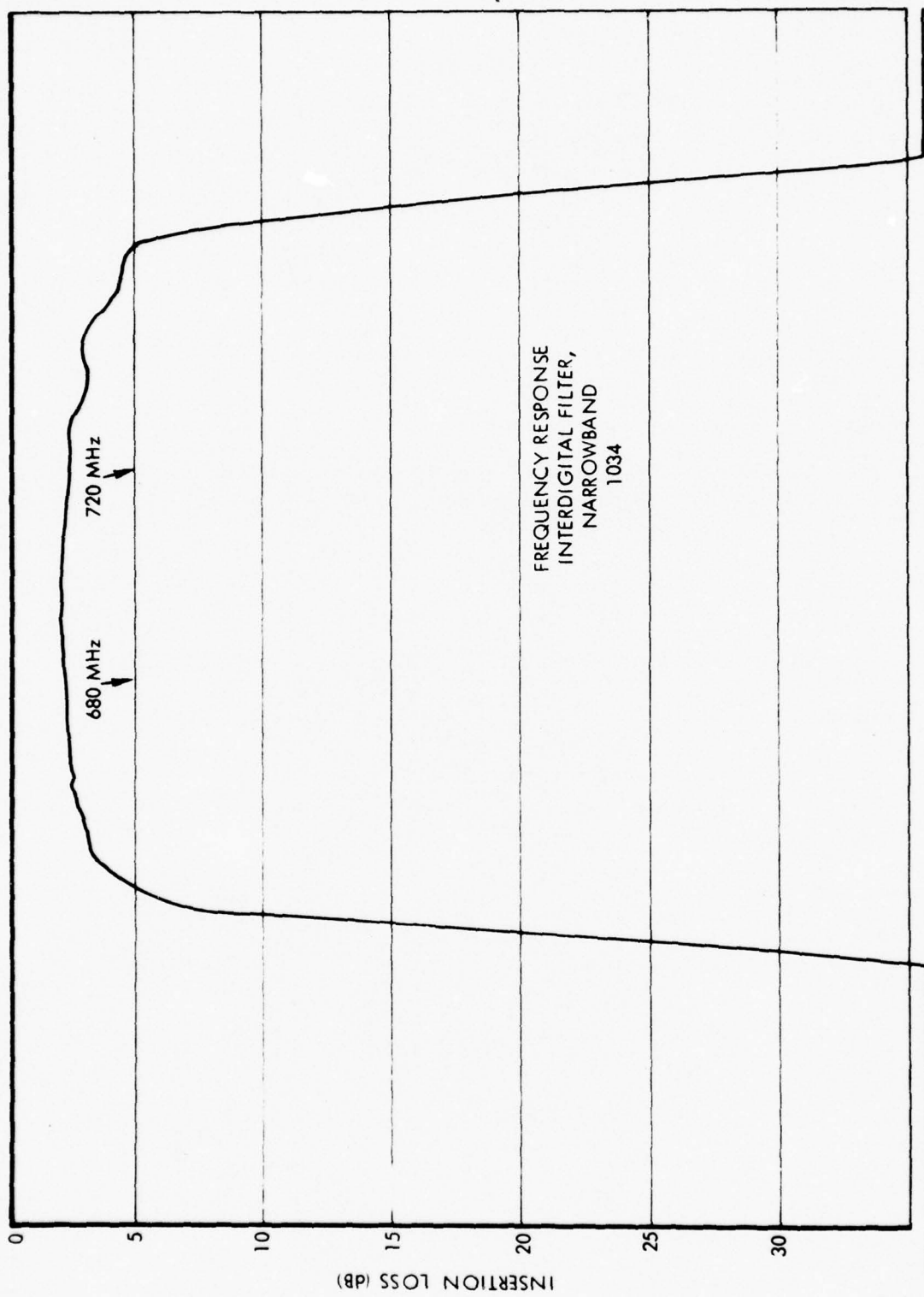

87924 - 17

Figure 2.1-17. Upconverter Narrowband Filter Amplitude Response

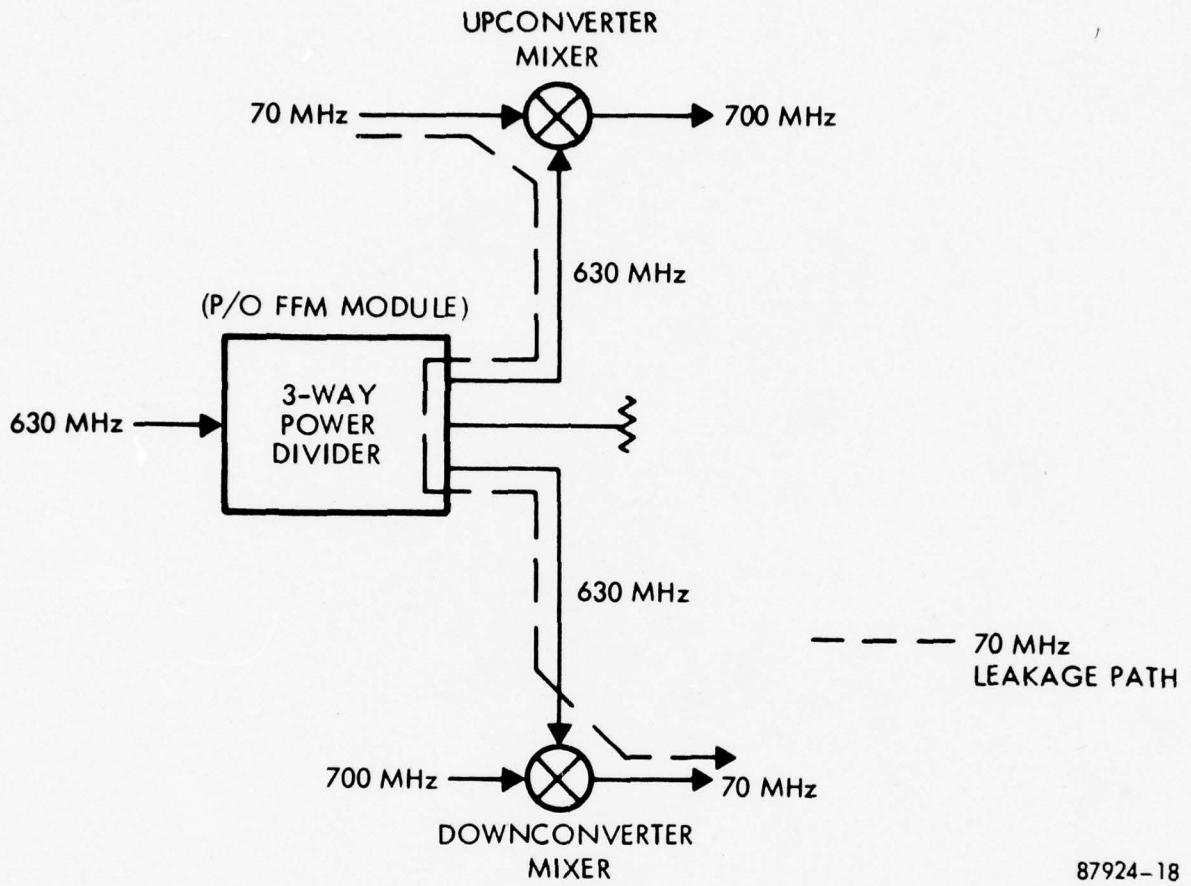

Figure 2.1-18. Upconverter/Downconverter 70 MHz Leakage Path

Figure 2.1-18 shows that there is only 54 dB of isolation between the 70 MHz line in the upconverter and the 70 MHz line in the downconverter. A 630 MHz highpass filter is required to give a total of at least 100 dB of isolation between converters at 70 MHz.

It was determined from filter attenuation curves that a 3-pole highpass filter with a break frequency of 575 MHz would give 60 dB rejection at 70 MHz.

The actual measured performance of the filter is shown in Figure 2.1-19.

#### 2.1.2.4 Local Oscillator Reject Filter

The local oscillator leakage through the 70/700 MHz mixer is at a power level of -27 dBm at the mixer output. Attenuation of the 630 MHz is partially accomplished by the narrowband filter but, because of the close proximity of 630 MHz to the lower 3-dB point of the filter, only 20 dB of filtering is accomplished. It is necessary to provide an additional filter to further attenuate the local oscillator signal.

Since the local oscillator signal is so close to the lower edge of the information band, the standard highpass all-pole filter cannot be considered. A 7-pole elliptic function filter with a modular angle of  $78^\circ$  was chosen because of its "skirt" response. A modular angle of  $78^\circ$  gives a rejection of 27 dB to 630 MHz with a break frequency of 670 MHz.

Test results of the filter indicated that rejection of 630 MHz was less than anticipated. After further tests, it was determined that the highest frequency resonant trap had insufficient Q due to the physical construction of the inductors. Improved performance was obtained by reducing the resonant frequency of that trap to coincide with that of the next lower resonance pole.

Figure 2.1-20 shows the amplitude response of the modified filter.

#### 2.1.2.5 Two-Way Combiner

It is necessary to combine the wideband 125 MHz channel and the narrowband 40 MHz channel so that a single chain of IF amplifiers may be used.

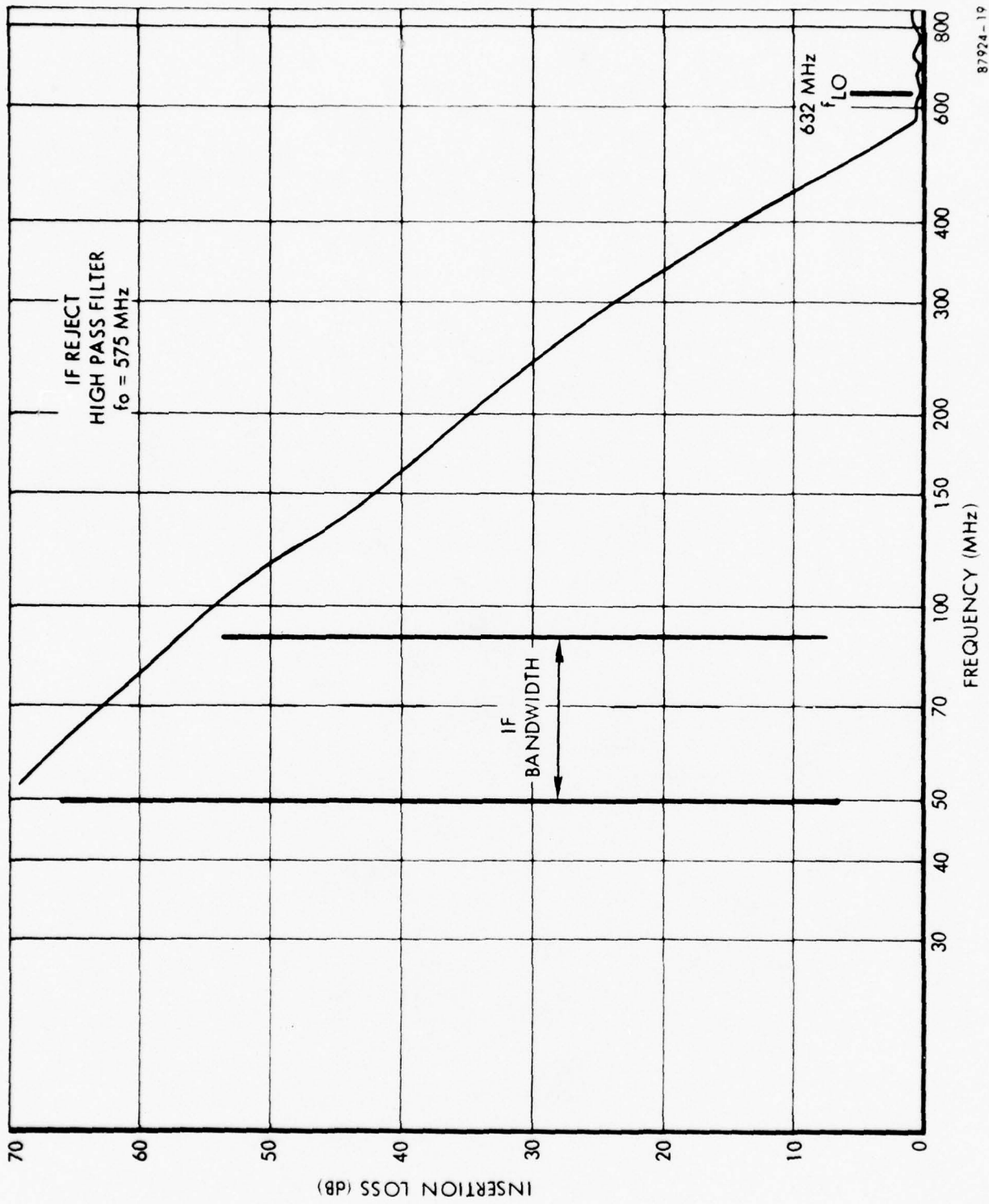

87924-19

Figure 2.1-19. IF Reject Highpass Filter Amplitude Response

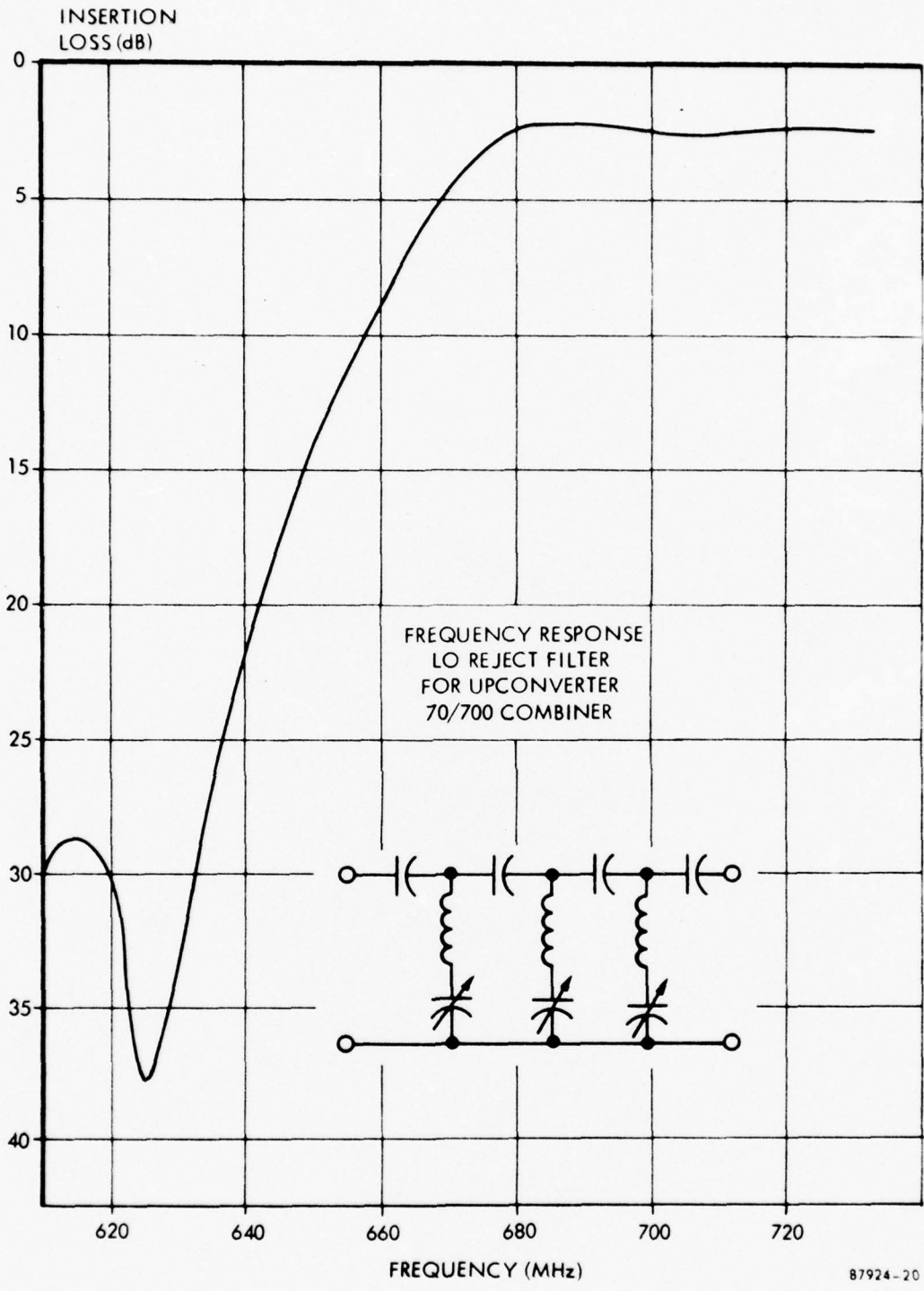

Figure 2.1-20. LO Reject Filter Amplitude Response

The combiner is a Wilkinson design and fabricated in the same manner as the two-way combiner portion of the four-way combiner/two-way divider in the downconverter (Paragraph 2.1.1.1).

#### 2.1.2.6 700 MHz Wideband Amplifiers

In order to achieve sufficient output power from the combiner to drive the 700 MHz/X-band upconverter, gain must be added to the converter. As in the downconverter, the upconverter must employ the use of wideband amplifiers so as not to disturb the phase linearity in the information bandwidth.

For the same reasons cited previously in the downconverter, Paragraph 2.1.1.2, Avantek amplifiers in the UTO-1000 series are employed. Calculations indicate that 50 dB of gain is necessary to obtain the proper output power from the module. A four-stage amplifier chain is used utilizing two 1001's, a 1002, and a 1003, in that order.

#### 2.1.2.7 Four-Way Divider

It had been planned originally to use a phased-array antenna requiring four 700 MHz/X-band upconverters. This configuration required the combiner upconverter to have four coherent outputs. Since the amplifier chain in the combiner had only one output, it became necessary to employ the use of a four-way power divider at its output.

The power divider is a Wilkinson device designed in the same manner as the four-way combiner portion of the four-way combiner/two-way divider described in Paragraph 2.1.1.1. It consists of three two-way combiners, each consisting of quarter-wavelength lines of 70.7 ohms characteristic impedance on an alumina substrate.

#### 2.1.3 Combiner Upconverter and Downconverter Test Results

The following paragraphs represent the performance budgets and test results for the combiner up- and down-converters. All tests were conducted at laboratory ambient temperature and at  $-25^{\circ}\text{F}$  and  $+125^{\circ}\text{F}$ . Since the converter performance is similar at the temperature extremities as it is at  $+75^{\circ}\text{F}$ , only the ambient data are presented except for amplitude and

phase response. The tests were conducted for both the narrowband (40 MHz) 70 MHz channel and the wideband (125 MHz) 700 MHz channel.

#### 2.1.3.1 Downconverter

The tabulated budgets and the corresponding test results for the narrowband and wideband channels are shown in Table 2.1-1. The fine-grained performance and the performance versus temperature are shown on the referenced figures.

#### 2.1.3.2 Upconverter

The tabulated budgets and the corresponding test results for the narrowband and wideband channels are shown in Table 2.1-2. The fine-grained performance and the performance versus temperature are shown on the referenced figures.

Table 2.1-1. Downconverter Test Results

	<u>Channel</u>	<u>Budget</u>	<u>Test Results</u>	<u>Reference Figure</u>
Amplitude Response	40 MHz	±0.25 dB	±0.20 dB	2.1-21
	125 MHz	±0.25 dB	±0.15 dB	2.1-22
Phase Response	40 MHz	±2.86°	+2.35°, -2.88°	2.1-23
	125 MHz	±7.20°	+5.46°, -3.21°	2.1-24
VSWR	Inputs	1.2:1	1.08:1	---
	Outputs	1.2:1	1.48:1 (70 MHz)	---
Output Levels	40 MHz	-5 dBm	-4.3 dBm	---
	125 MHz	-5 dBm	-5.1 dBm	---
Spurious Outputs	40 MHz	---	-51 dBm at 140 MHz	---
	125 MHz	---	-43 dBm at 2100 MHz	---
			-61 dBm at 2100 MHz	---
Image Rejection	40 MHz	-22 dBm	-60 dBm	---
LO Rejection	40 MHz	-83 dBm	-53 dBm	---
Noise Figure		21 dB	20.5 dB	---
Gain Compression (-15 dBm Input)	40 MHz	0.5 dB	0.5 dB	---
	125 MHz	0.5 dB	0.5 dB	---
Differential Time Delay	40 MHz	---	+7.0, -3.0 NSEC.	2.1-25
	125 MHz	---	+3.0, -4.0 NSEC.	2.1-26

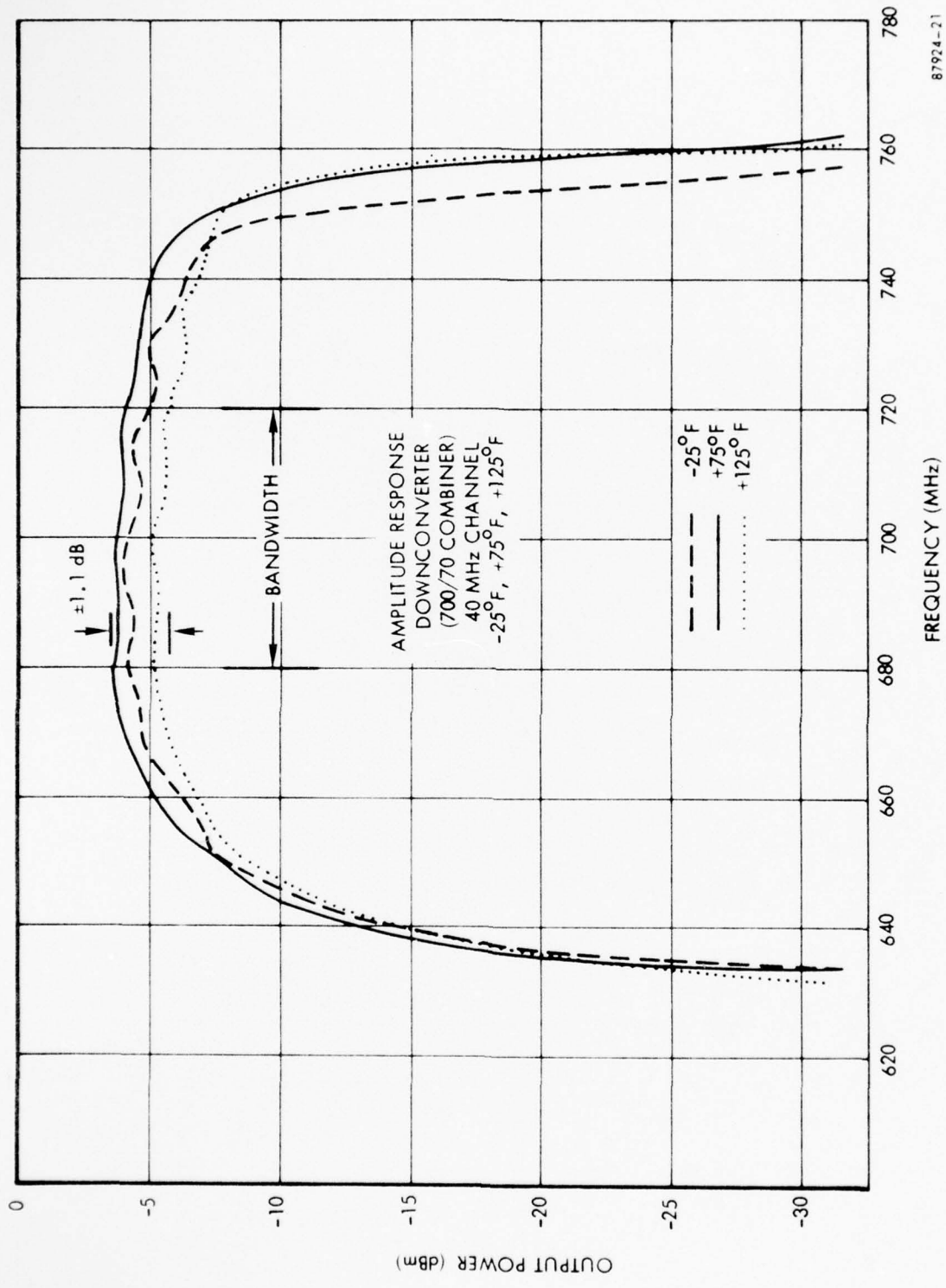

87924-21

Figure 2.1-21. Downconverter Narrowband Channel Amplitude Response

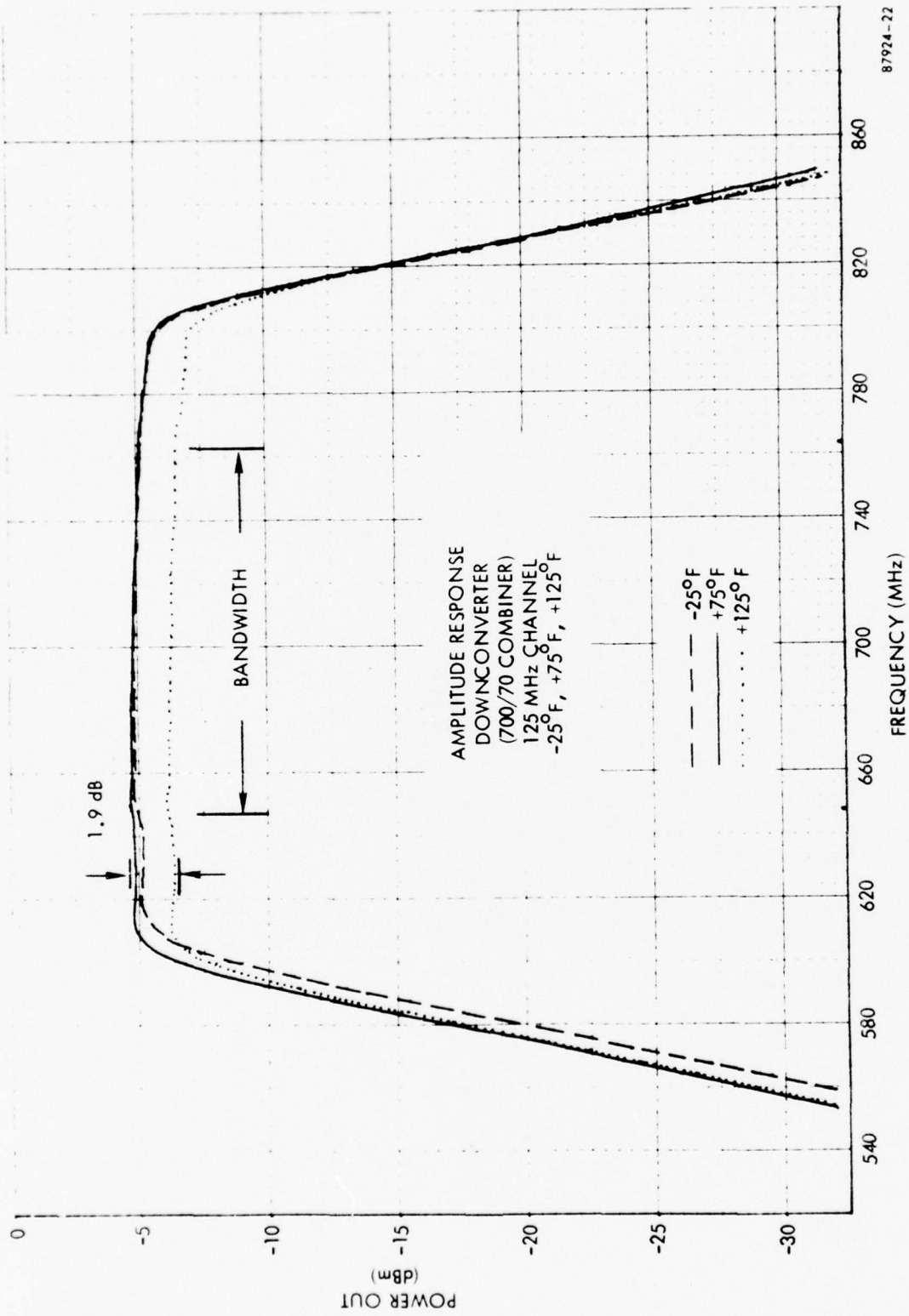
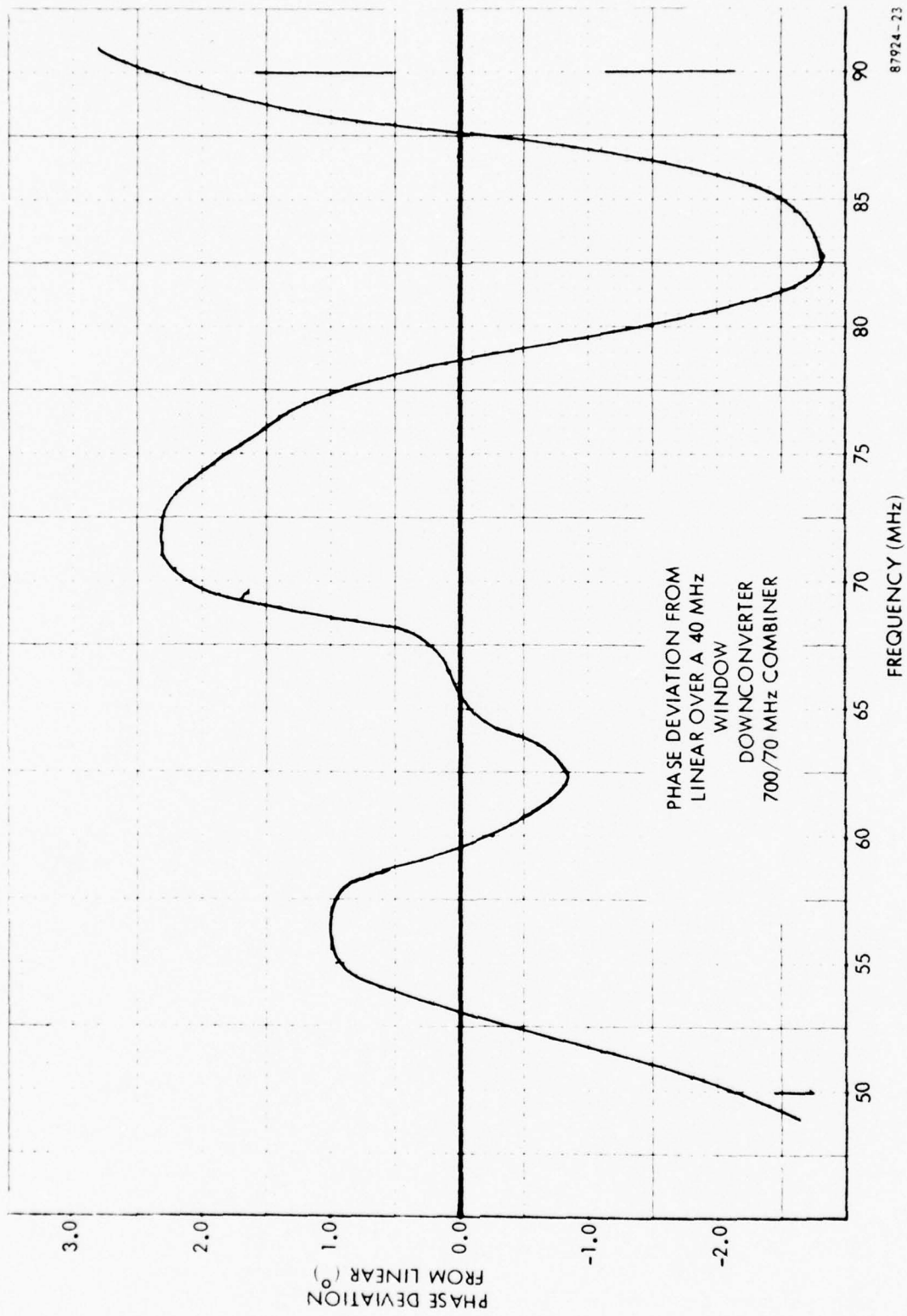

Figure 2.1-22. Downconverter Wideband Channel Amplitude Response



87924-23

Figure 2.1-23. Downconverter Narrowband Channel Phase Response

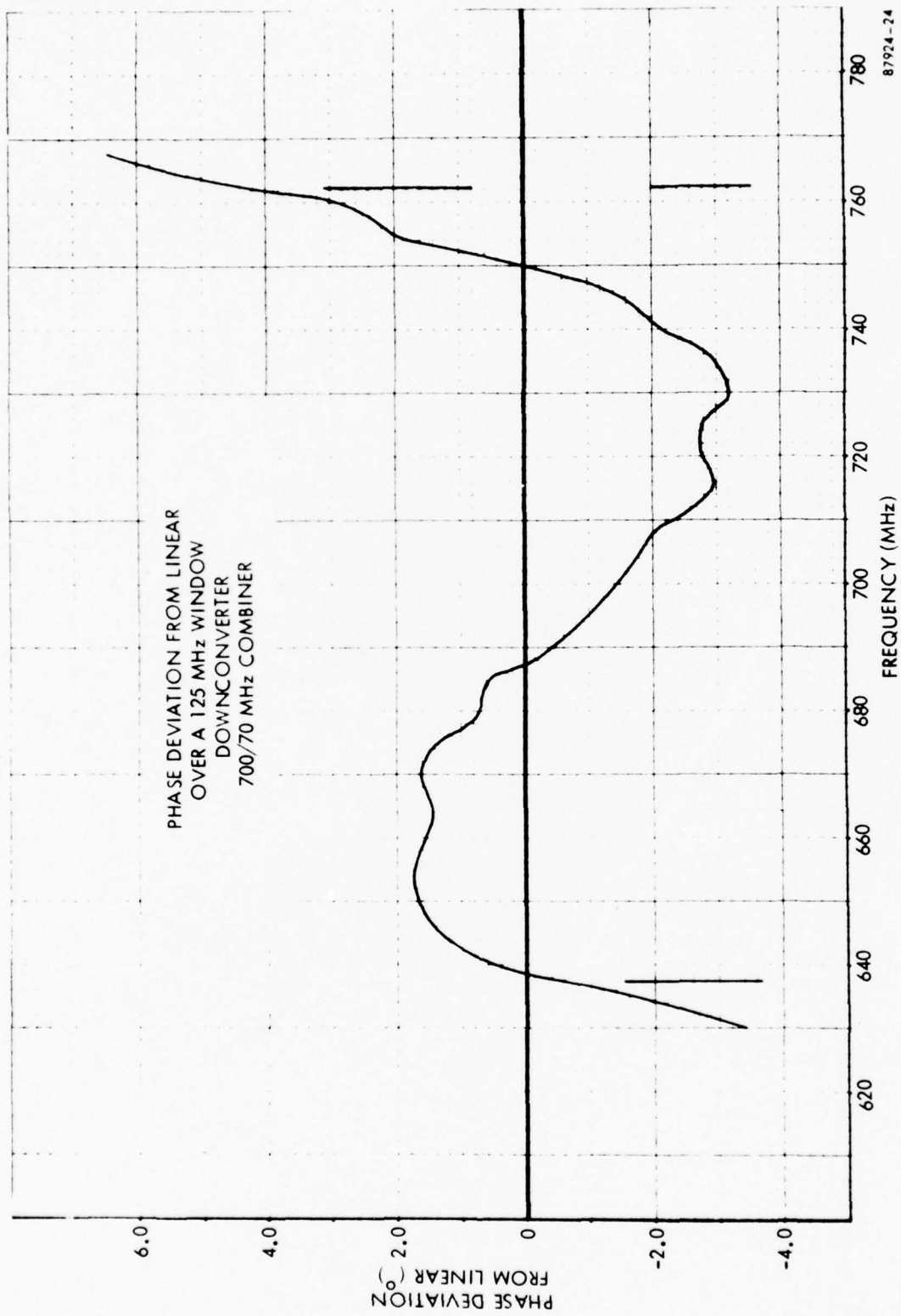

Figure 2.1-24. Downconverter Wideband Channel Phase Response

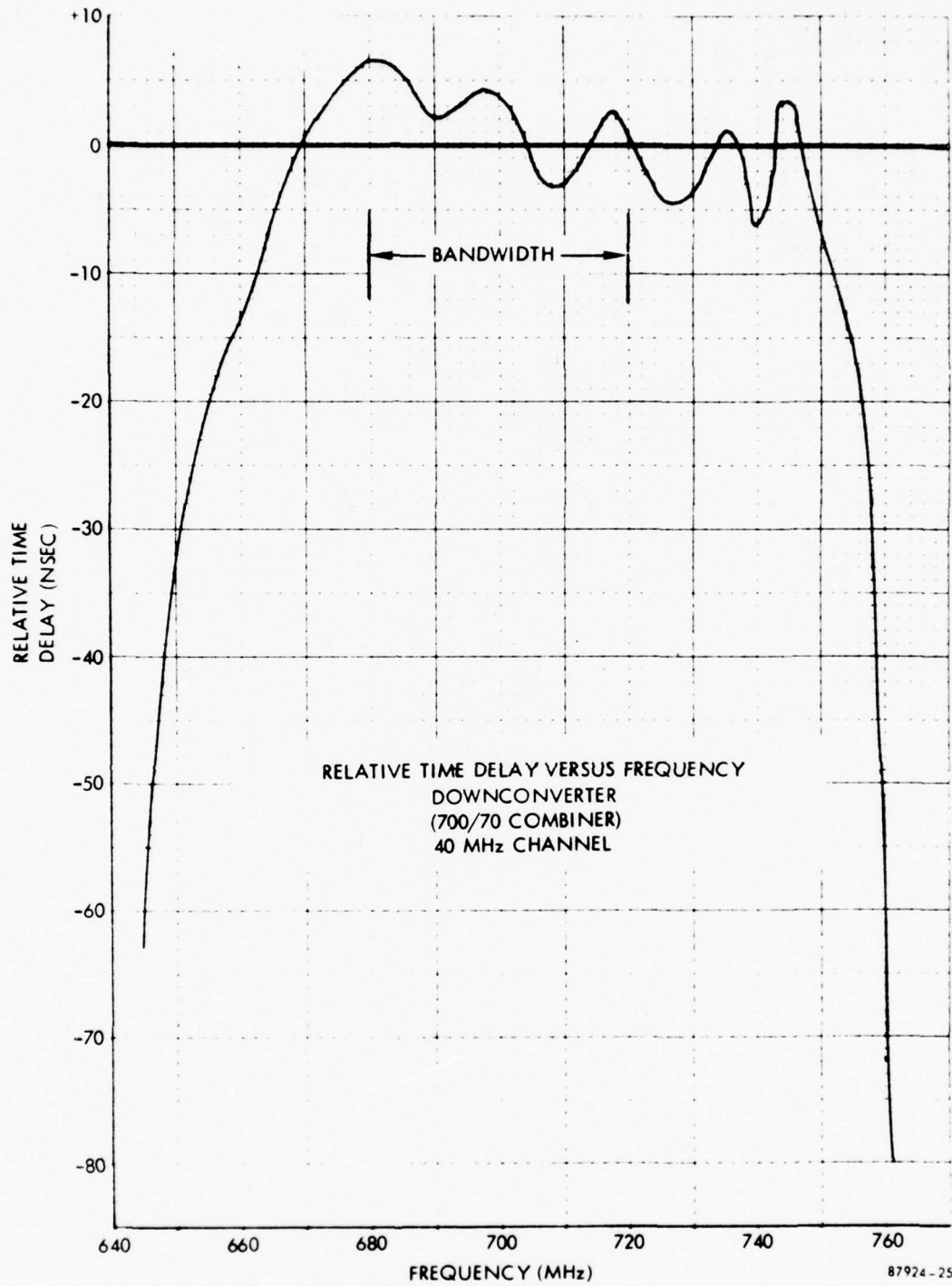

Figure 2.1-25. Downconverter Narrowband Channel Delay Response

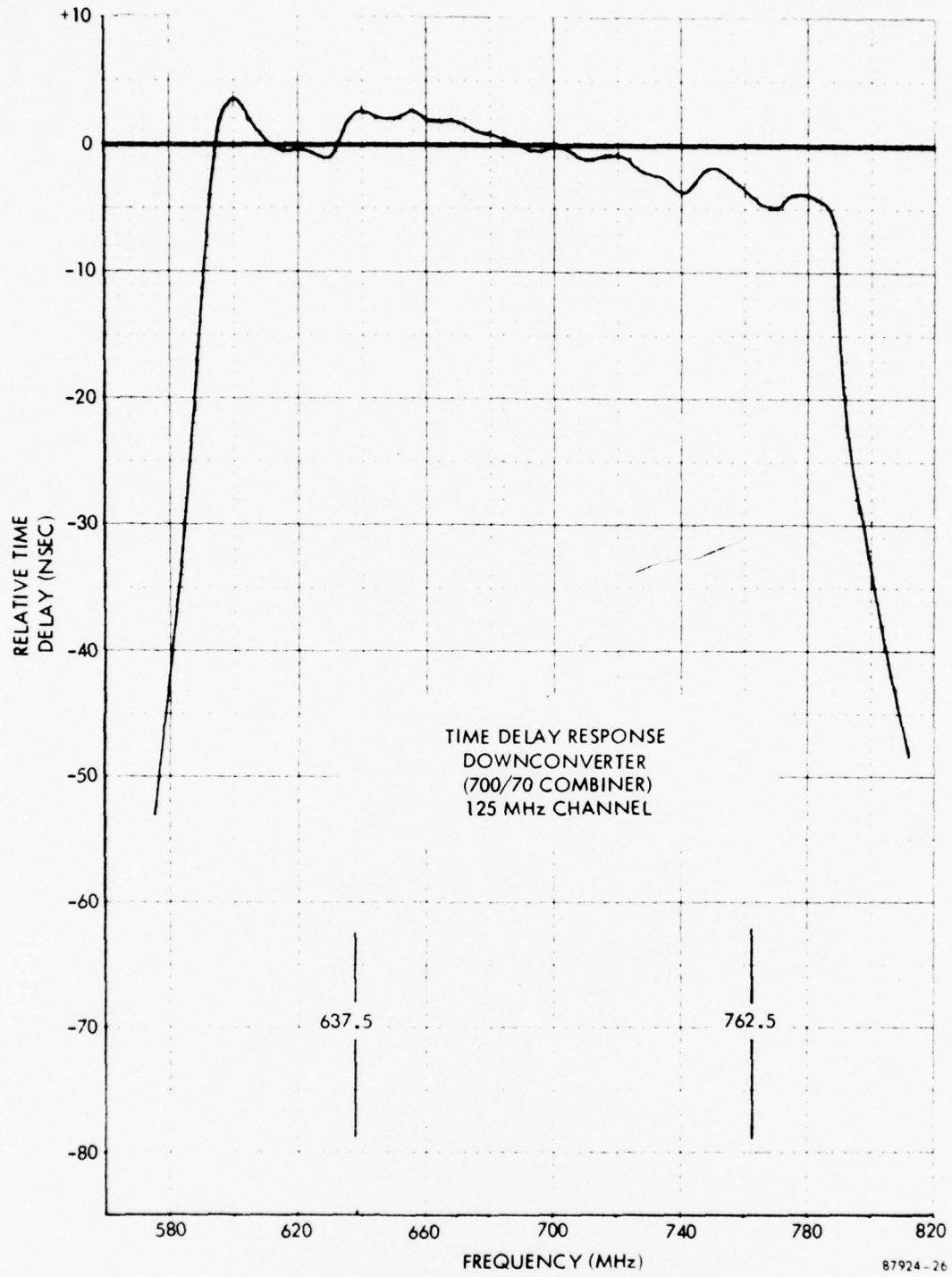
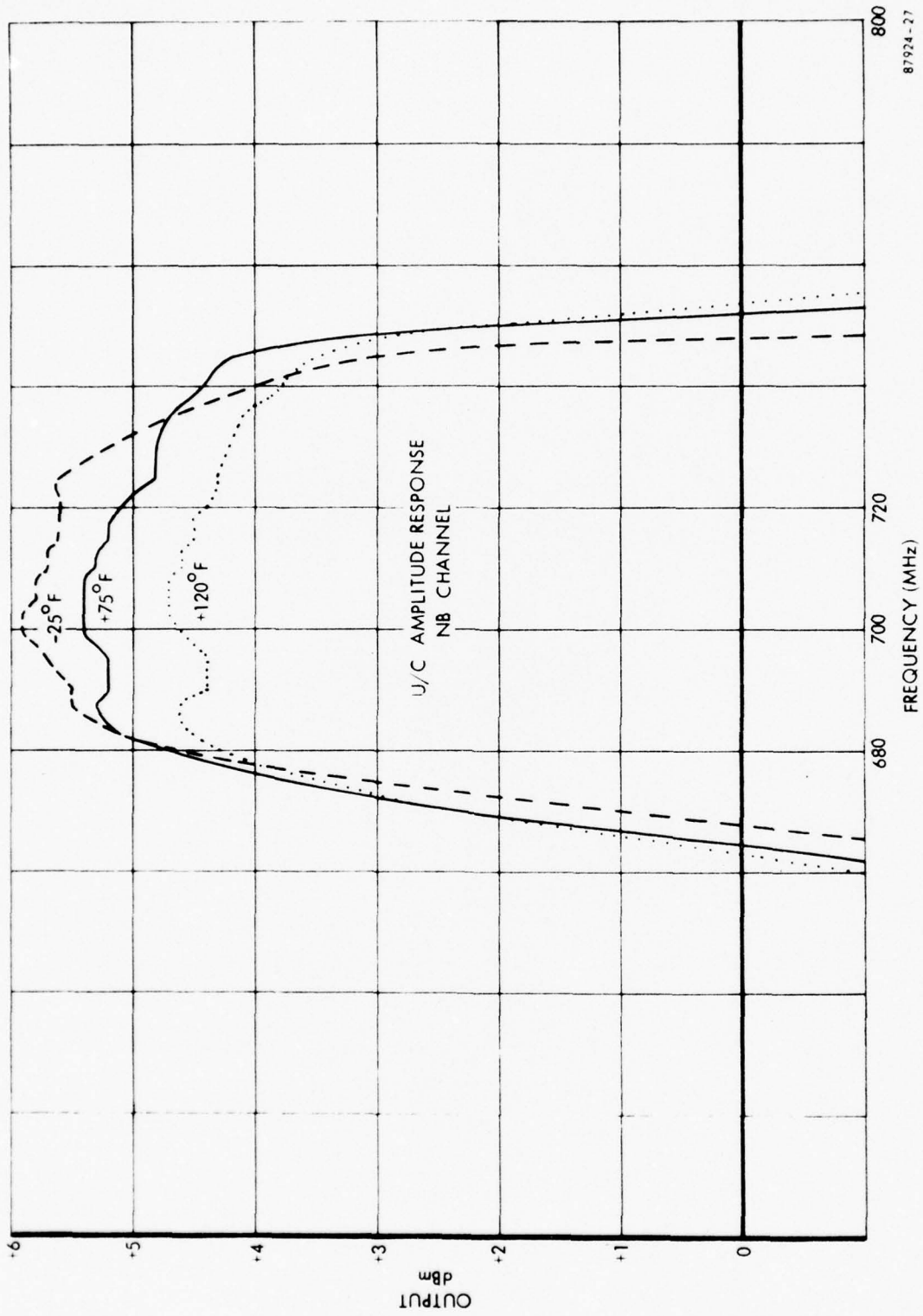

Figure 2.1-26. Downconverter Wideband Channel Delay Response

Table 2.1-2. Upconverter Test Results

	<u>Channel</u>	<u>Budget</u>	<u>Test Results</u>	<u>Reference Figure</u>
Amplitude Response	40 MHz	±0.25 dB	±0.20 dB	2.1-27
	125 MHz	±0.25 dB	±0.25 dB	2.1-28
Phase Response	40 MHz	±2.86°	+7.08°, -3.53°	2.1-29
	125 MHz	±7.20°	+7.72°, -3.05°	2.1-30
Output Levels	40 MHz	+4 dBm	+3.8 dBm	---
	125 MHz	+4 dBm	+4.5 dBm	---
Isolation Between Outputs		20 dB	12.9 dB	---
Spurious Outputs	40 MHz	-80 dB	-59 dB at 630 MHz	---
			-35 dB at 140 MHz	---
	125 MHz	-80 dB	-55 dB at 210 MHz	---
			-65 dB at 630 MHz	---
Gain Compression	40 MHz		-36 dB at 1400 MHz	---
			-54 dB at 2100 MHz	---
				2.1-31



87924-27

Figure 2.1-27. Upconverter Narrowband Channel Amplitude Response

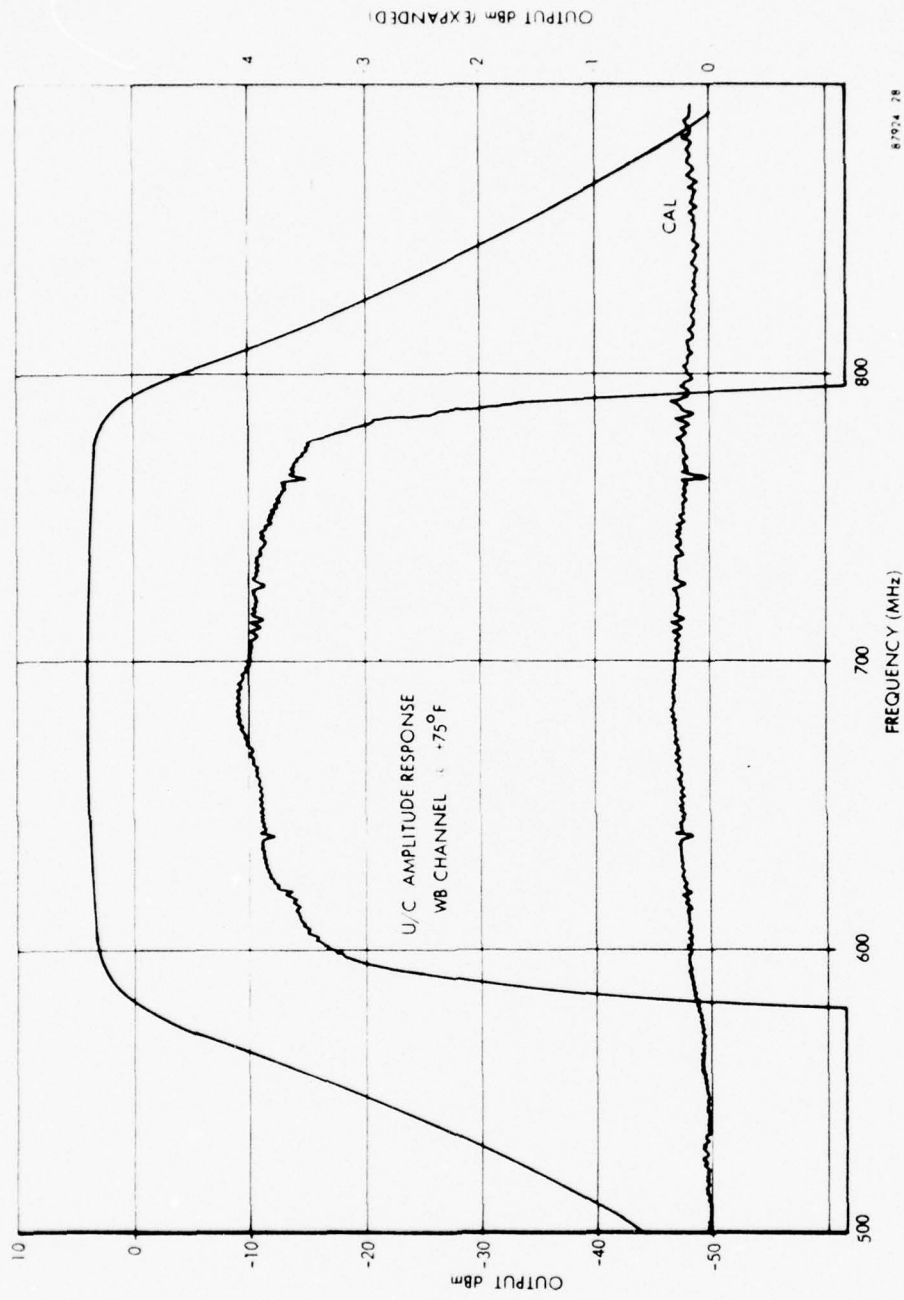

Figure 2.1-28. Upconverter Wideband Channel Amplitude Response

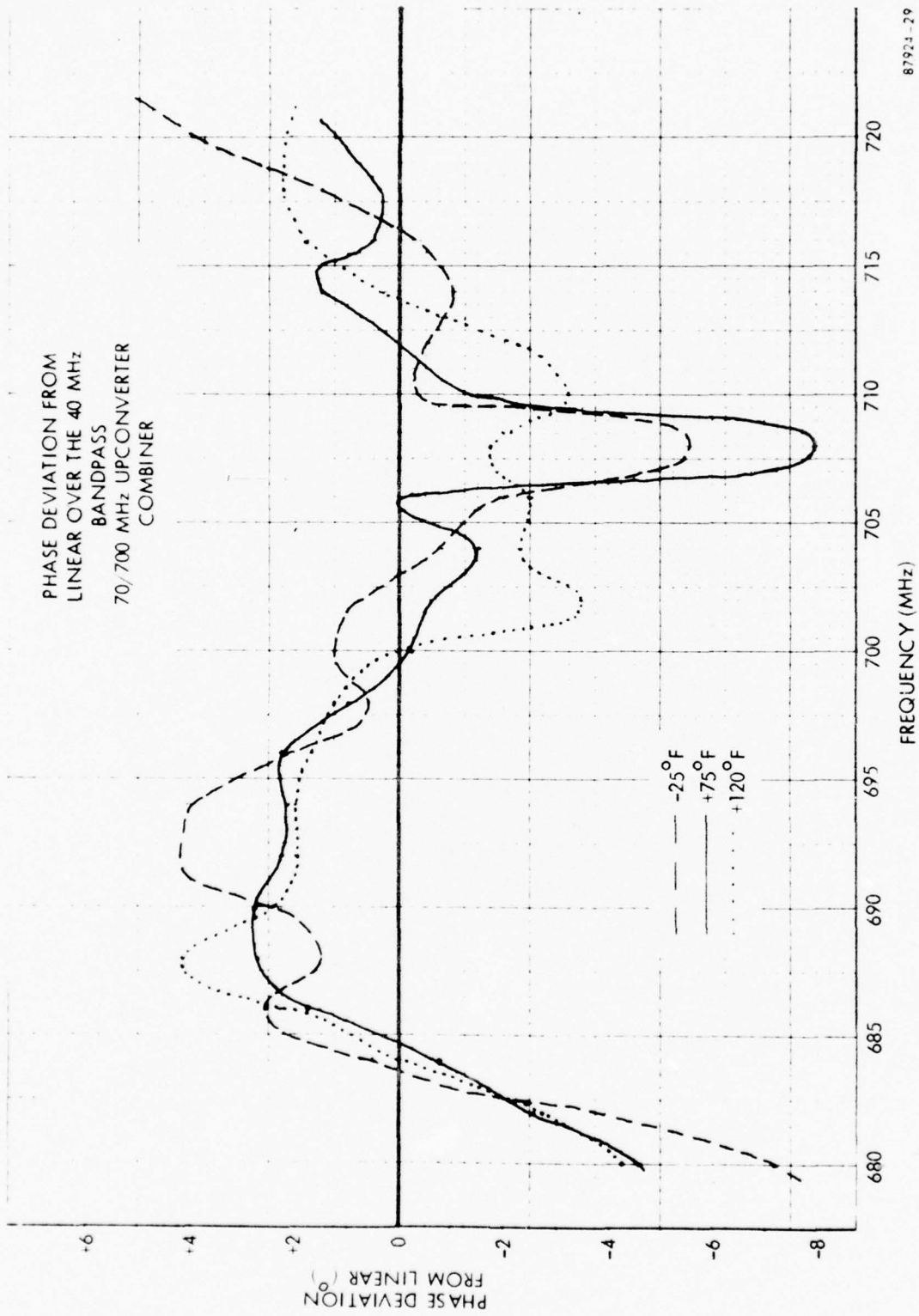
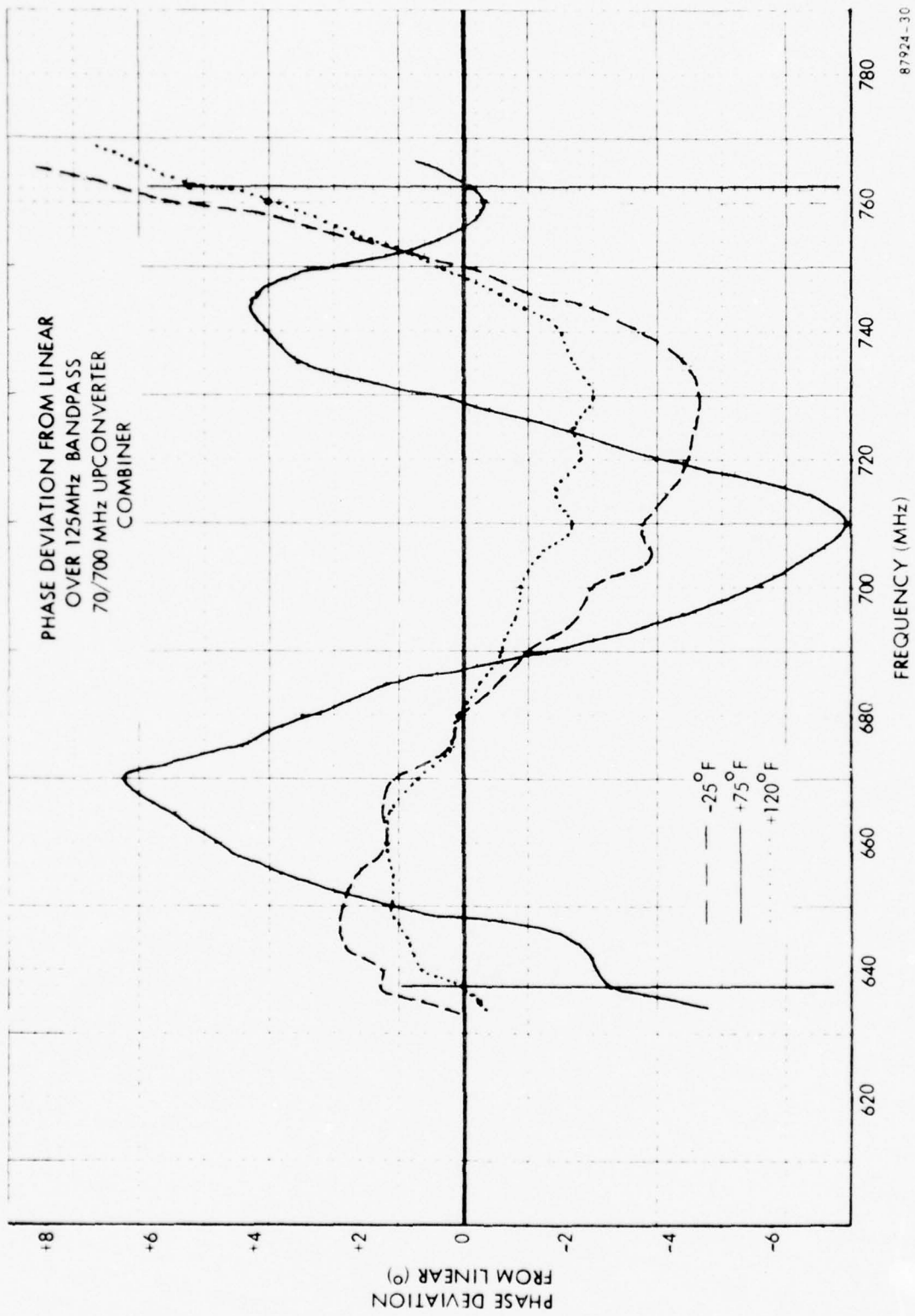
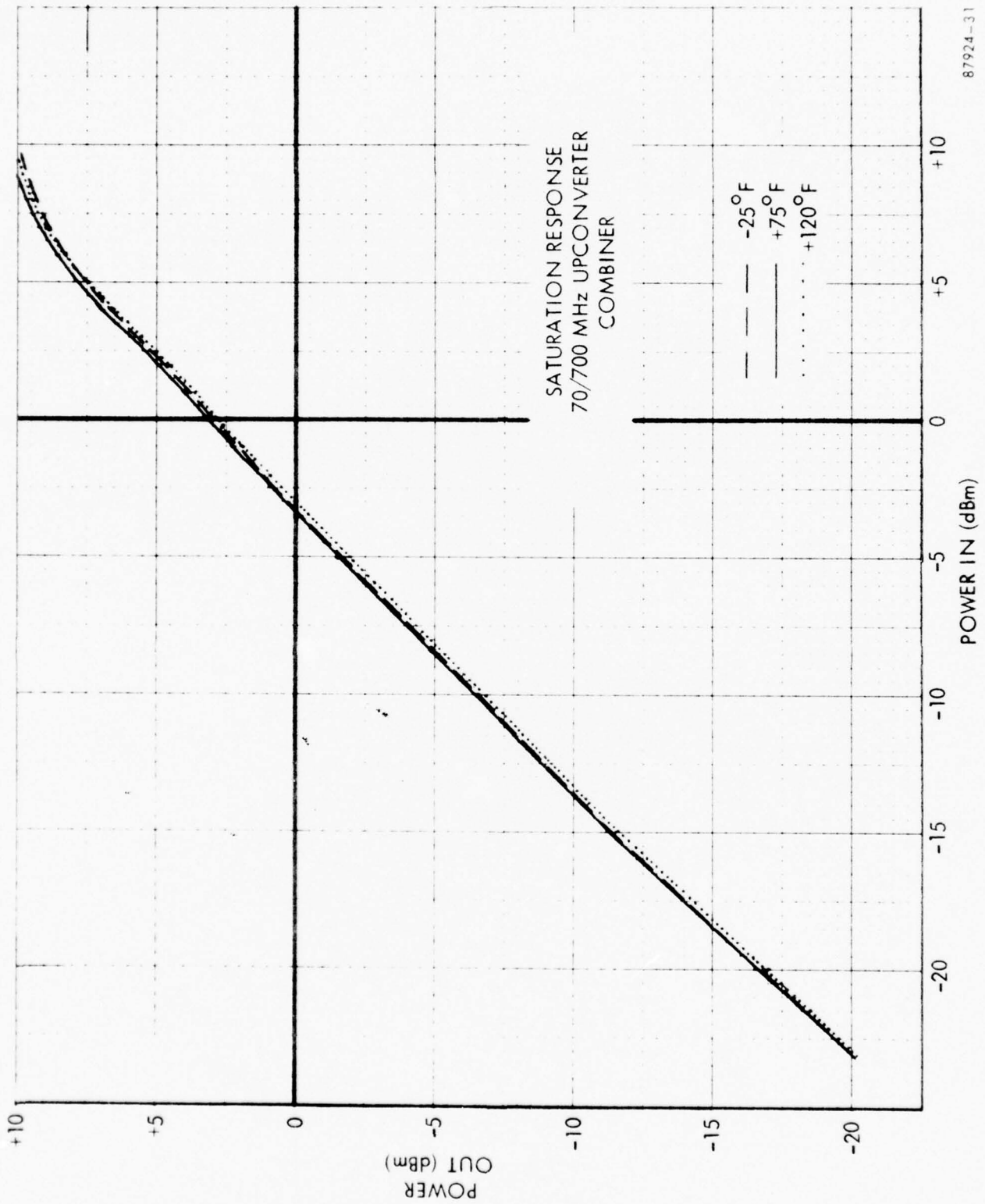

Figure 2.1-29. Upconverter Narrowband Channel Phase Response



87924-30

Figure 2.1-30. Upconverter Wideband Channel Phase Response



87924-31

Figure 2.1-31. Upconverter Saturation Response

## 2.2 Fixed-Frequency Multiplier Module

Both the 700/70 MHz downconversion and the 70/700 MHz upconversion utilize a 630 MHz local oscillator. The 630 MHz local oscillator is derived in the FFM (fixed-frequency multiplier) module by X126 multiplication of the 5 MHz standard frequency. This module accepts a 5 MHz input at -10 dBm and delivers three isolated 630 MHz outputs at +10 dBm each. One output goes to the 700/70 MHz downconverter, the second goes to the 70/700 MHz upconverter and the third is terminated. (In the original system configuration, the third output was used in a second 700/70 MHz downconverter channel.) The output levels of the FFM are required to be stable over the operating temperature range. All spurious outputs must be down at least 60 dB.

Figure 2.2 is a block diagram of the FFM module. Referring to this diagram, the 5 MHz input signal is multiplied by 18, to 90 MHz, in the first card assembly by X6 and X3 active multipliers. A voltage-starved buffer stage is used at the input of this module as a limiter to prevent the highly nonlinear multiplier stages from being subjected to variations in input signal level. Extensive interstage filtering is used to eliminate close-in harmonics of the 5 MHz input signal.

The 90 MHz output of the X18 card is used to drive a X7 active multiplier to produce 630 MHz. A 3-dB pad is placed on the input of the multiplier to ensure interstage stability. A Hewlett-Packard 35821E transistor is used as the active device for the X7 multiplier. A four-pole Butterworth bandpass filter is used to select the 630 MHz spectral line from the output of the multiplier. Another HP35821E transistor is used as a 630 MHz amplifier to scale the filtered signal to the proper level. Using vendor-supplied S-parameters, a computer analysis was performed to generate an unconditionally stable amplifier with a small-signal gain of 19 dB. A five-pole, 0.5 dB Chebyshev lowpass filter is used on the output of the 630 MHz amplifier to reject any harmonics generated by the amplifier.

Temperature compensation of the 30 MHz, 90 MHz and 630 MHz buffer stages was required to stabilize the multiplier output level over the temperature range. This compensation takes the form of a silicon diode in each base bias network to compensate for the transistor's  $V_{BE}$  variation with temperature. The resulting FFM power output versus temperature is tabulated below.

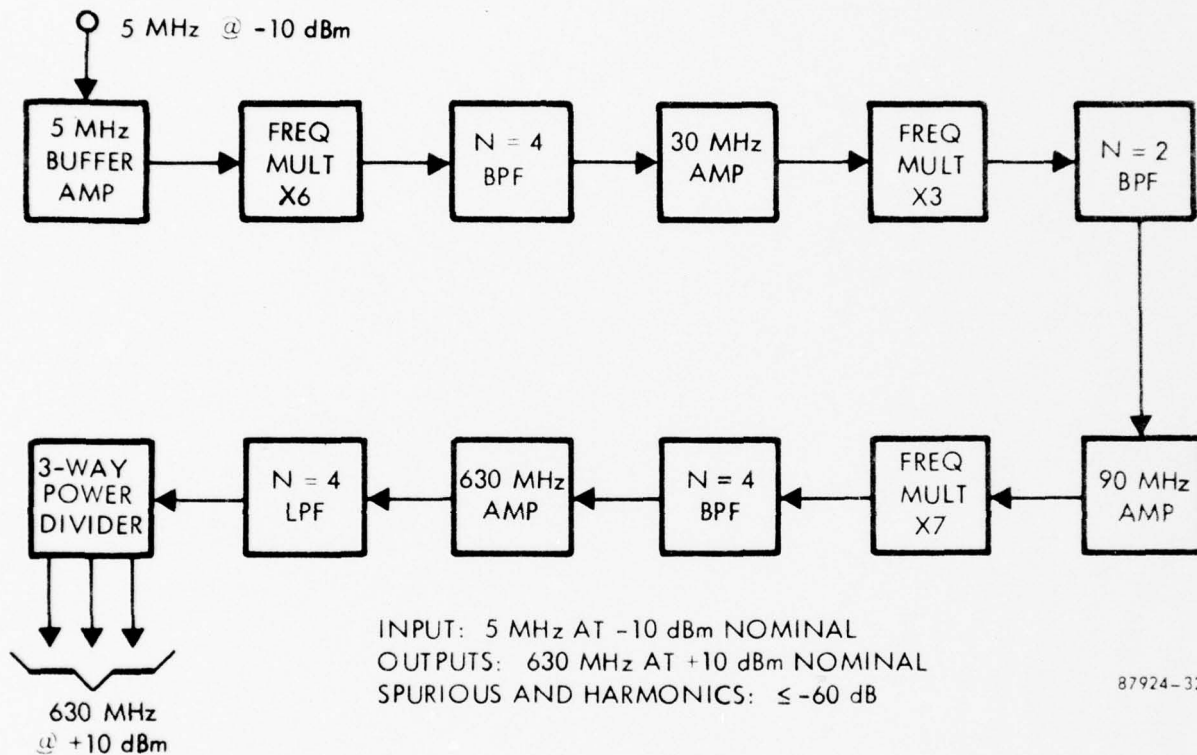

Figure 2.2. FFM Module Block Diagram

<u>Temperature (°C)</u>	<u>P<sub>out</sub> (dBm)</u>
-50	+10.70
-25	+10.85
+25	+11.20
+50	+10.20
+60	+ 9.70

All spurious and harmonic outputs were measured to be greater than 70 dB down with respect to the desired 630 MHz output.

### 2.3 X-Band/700 MHz Downconverter and 700 MHz/X-Band Upconverter

The transmit and the receive channels require frequency conversion from 700 MHz to X-band and X-band to 700 MHz, respectively. Both converters are designed in hybrid-micro-integrated-circuit configurations to conserve size and weight.

A block diagram of the X-band to 700 MHz downconverter is shown in Figure 2.3-1. The X-band input signal passes through two isolators to the RF port of the mixer. The local oscillator signal, at 700 MHz below the incoming RF signal, passes through a 5-pole parallel-line-coupled filter to the LO port of the mixer through an isolator. The 700 MHz IF output of the mixer is then coupled to a 2-stage linear amplifier with 30 dB gain. This output IF signal, at a nominal level of -24 dBm, drives the input port of the combiner downconverter.

The major internal subassemblies of the downconverter consist of two S-4423 isolators, S4419 isolator, T-415 bandpass filter, SST 113 single balanced mixer and a T-474-1A IF amplifier. The input signal is at a frequency between 7.25 and 7.75 GHz and the output is 700 MHz.

A block diagram of the 700 MHz to X-band upconverter is shown in Figure 2.3-2. The 700 MHz input signal from the combiner upconverter at a level of +4 dBm, feeds the IF input port of the mixer. The local oscillator signal, at a frequency 700 MHz below the RF output, passes through a 5-pole bandpass filter and an isolator to the mixer. The RF output at the transmit frequency is at a level 10 to 12 dB down from the input signal and passes through

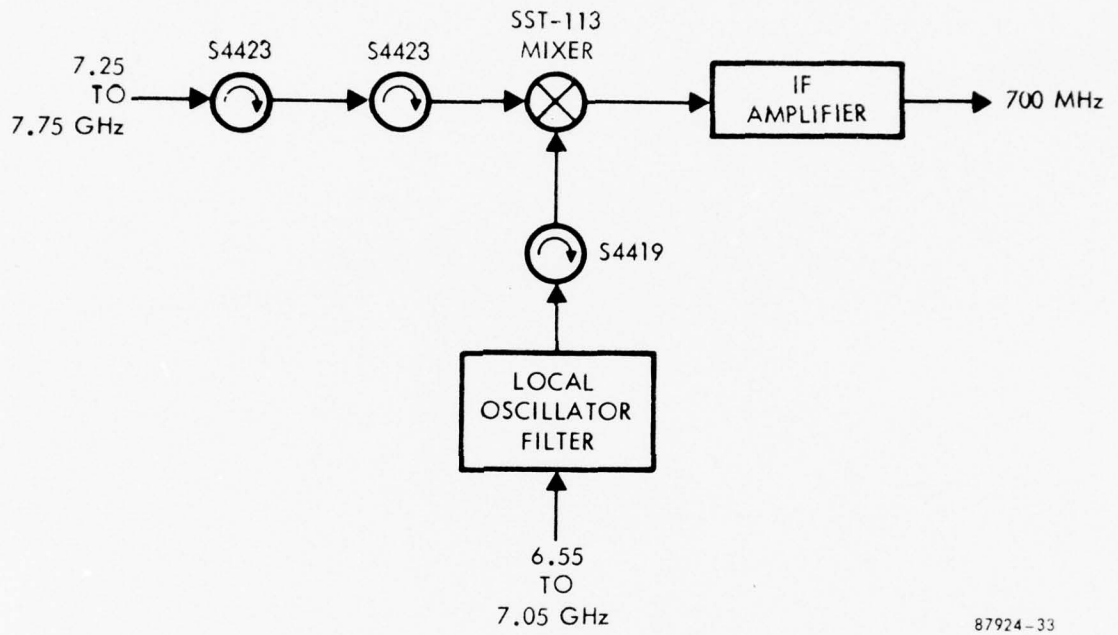

87924-33

Figure 2.3-1. Block Diagram of X-Band/700 MHz Downconverter

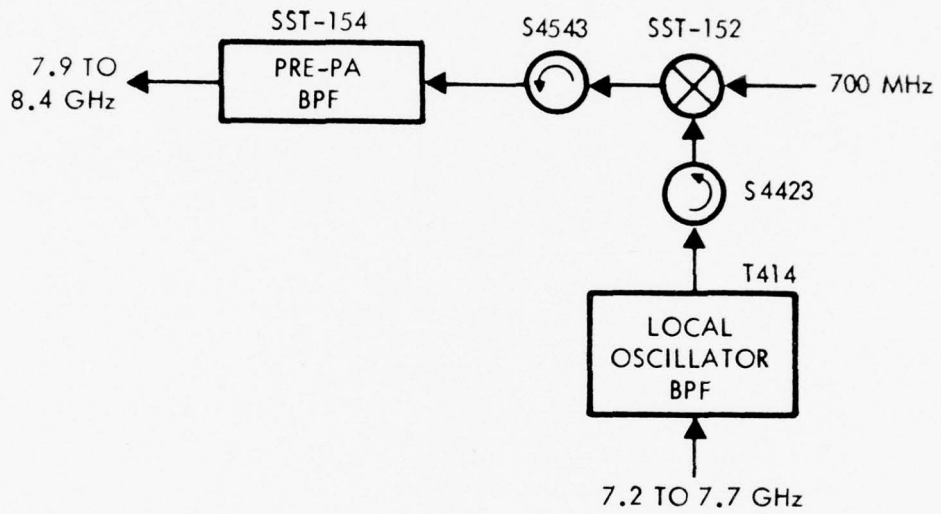

87924-34

Figure 2.3-2. Block Diagram of 700 MHz/X-Band Upconverter

an isolator and 15-pole bandpass filter. The output signal is at a level of -10 dBm and drives the transmit power amplifier.

The major internal subassemblies of the upconverter consists of a local oscillator bandpass filter (T-414), a 15-element parallel-line-coupled ceramic bandpass filter (SST-154), a single balanced mixer (SST-152), and local oscillator and RF isolators. The IF input signal is 700 MHz and the X-band output signal is between 7.9 and 8.4 GHz.

The individual circuits of the downconverter and upconverter are discussed in the following paragraphs.

### 2.3.1 X-Band/700 MHz Downconverter

#### 2.3.1.1 Mixer

A mixer is required in the downconverter to translate the incoming receive frequency to a 700 MHz IF. The mixer must accept any receive frequency from 7.25 to 7.75 GHz and an appropriate local oscillator in the 6.55 to 7.05 GHz range, and provide an IF output centered at 700 MHz with a flat bandwidth of 125 MHz.

A balanced mixer configuration was selected because of its inherent noise cancellation characteristics and its relative insensitivity to local oscillator injection level.

A beam-lead hot-carrier diode manufactured by Hewlett-Packard was selected to be used in pairs in the mixer. This diode, the 5082-2709, is partially characterized at X-band, is well suited for microstrip packaging, and is manufactured with highly repeatable processes that ensure close unit-to-unit uniformity.

In order to match the diode to 50 ohms at both RF and IF, a characterization of the complex impedance of the diode was done. The nominal local oscillator injection level is +10 dBm (10 mW). But, to allow for slightly less than nominal drive, the diode was characterized at 5 and 7.5 mW as well as 10 mW. The measurements were made at a local oscillator frequency of 6800 MHz, the middle of the band.

The diode RF impedance was found to be rather insensitive to LO drive level, varying from  $41 + j 8.75$  ohms at 10 mW drive to  $36.5 + j 0.5$  ohms at 5 mW drive. The value

at 7.5 mW drive,  $37.75 + j 5.0$  ohms, was taken as nominal, and RF matching circuits were designed on that basis.

Matching networks were designed by using a Radiation microwave optimization program on a Univac 1108 computer to minimize the RF input VSWR over the 500 MHz RF bandwidth and 125 MHz IF bandwidth. These networks were fabricated in microstrip on a 99.5 percent alumina substrate.

It was also necessary to design a hybrid junction. In a balanced mixer, some sort of hybrid is required to properly combine the RF and LO signals and to provide isolation between the RF and LO ports. Three types of hybrids were considered:

- a. Symmetrical  $90^\circ$  hybrid
- b.  $180^\circ$  rat-race hybrid
- c. 3-branch, branch-line hybrid

Both a symmetrical  $90^\circ$  hybrid and a  $180^\circ$  rat-race hybrid were built and tested. The rat-race hybrid was found to have better isolation, but the  $90^\circ$  hybrid design was selected because of its more suitable geometry.

Figure 2.3-3 is a photograph of the overall geometry of the final mixer, considerably magnified. The diodes are connected across the short blank spaces between transmission lines at the top and bottom sides, midway across the length of the board. The RF input is at lower left, the LO input at top left, and the IF output at the right.

The IF output match was actually not optimized for either minimum conversion loss or best noise match to the IF amplifier following it. Measurements made of the mixer conversion loss at various RF and LO frequencies gave figures of 7.5 to 8.0 dB. Inserting a triple-stub tuner at the IF output and tuning for minimum conversion loss resulted in measured conversion loss ranging from 6.0 to 7.0 dB.

When the mixer was integrated with the rest of the X-band/700 MHz downconverter, overall noise figures of 16.0 to 17.0 dB were measured. Inserting a triple-stub tuner between the mixer and the IF amplifier and tuning for best noise match resulted in a noise figure of 15.5 dB.

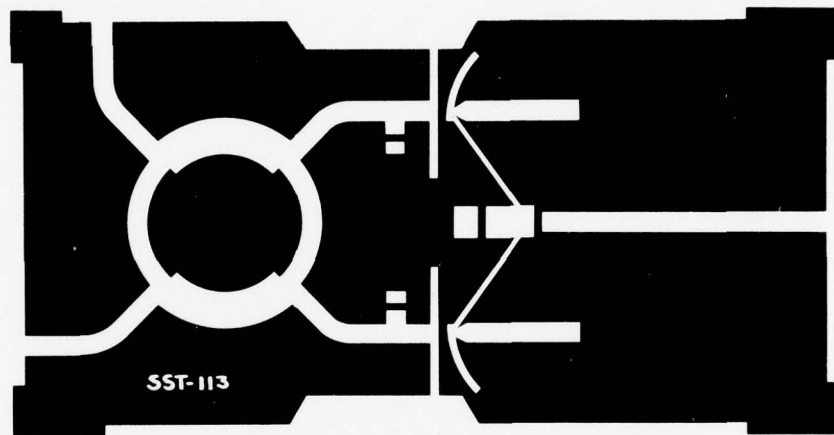

87924-35

Figure 2.3-3. X-Band Mixer Geometry

### 2.3.1.2 Local Oscillator Filter

Because it is imperative that undesired signals be prevented from reaching the mixer, band-limiting is required in the local oscillator line. Any unwanted signal that reaches the mixer may produce intermodulation products which fall in the 700 MHz IF information bandwidth.

The bandpass filter is a parallel-line-coupled filter in a .050 inch microstrip configuration to conserve size and weight. From filter attenuation charts, it was decided that five elements of filtering with 0.1 dB ripple was sufficient to reject all undesired signals to the point where they would not degrade system operation. The bandwidth was chosen so that the local oscillator frequency range of 6550 MHz to 7050 MHz would be allowed to pass. Refer to 2.13.1 for the detailed design discussion.

The physical configuration of the resulting filter is shown in Figure 2.3-4.

### 2.3.1.3 Isolators

In order to provide the necessary isolation between the mixer input ports and their source at a minimal insertion loss, isolators are used in the RF and LO lines to assure a good source VSWR at the RF port of the mixer and prevent the local oscillator signal from propagating up the RF line. The cascaded isolators are placed at the RF port of the mixer. A single isolator at the local oscillator port assures a good source VSWR to the mixer and prevents the RF signal from getting into the local oscillator chain.

It was initially planned that isolators of stripline configuration be used in the converter because of their generally superior performance characteristics. Insertion loss is lower and isolation higher than with most other isolator configurations. The difficulty that arises is that of impedance matching the stripline circulator to 50-ohm microstrip lines. The planned solution was to perturbate the characteristic impedance of the microstrip line to match the isolator to 50 ohms. Although the success of accomplishing this impedance matching would be highly probable, the procedure is an iterative one and it is possible that the number of iterations could be numerous.

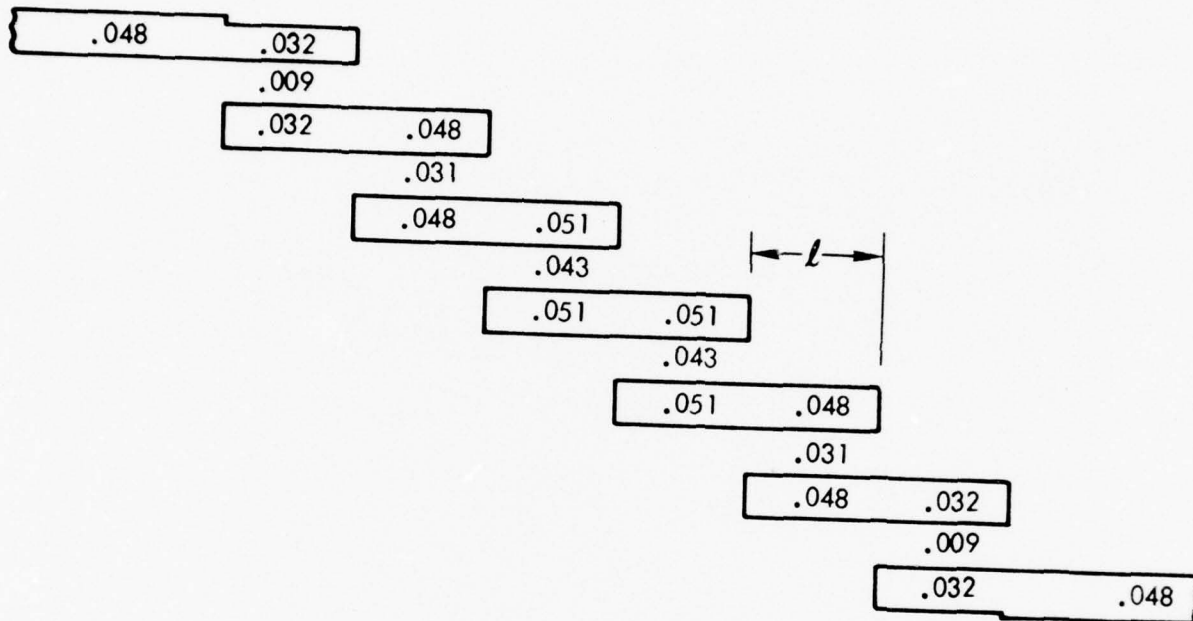

$$l = \lambda/4 \text{ at } f_0$$

87924-36

Figure 2.3-4. Layout of the Filter

For this reason, it was decided to investigate an alternative approach to solving the problem. It was decided that microstrip isolators whose ports were already matched to 50 ohms would perform the task required if their electrical characteristics were acceptable.

Sonoma Engineering and Research Corporation was chosen as the vendor to supply isolators for the converters with the following specified performance characteristics:

1. Insertion Loss: 0.50 dB or less
2. Isolation: 20 dB or greater
3. VSWR: 1.25 to 1 or less
4. Temperature Range:  $-25^{\circ}\text{F}$  to  $+125^{\circ}\text{F}$

The Sonoma Model S-4423 isolators used in the RF line are specified for the frequency band from 7.25 to 7.75 GHz. Since two of these isolators are used in series in the downconverter, 40 dB of isolation is provided.

The S-4419 isolator has the same electrical characteristics as the S-4423, except the frequency specified is 6.55 to 7.05 GHz. There is one S-4419 located between local oscillator bandpass filter (T-415) and X-band mixer (SST 113).

The S-4419 Serial Number 1 and S-4423 Serial Numbers 1 and 4 series isolators were mounted independently on a fixture and evaluated for insertion loss, isolation and VSWR over their respective frequency ranges. Isolation and insertion loss were also measured on two S-4423 isolators connected in series. The measured insertion loss, isolation and VSWR of the S-4419 and the two S-4423's met or exceeded the specified performance characteristics listed above.

#### 2.3.1.4 IF Amplifier

In order to drive the 700 MHz to 70 MHz combiner downconverter at its proper level, amplitude scaling in the X-band downconverter is required. The requirements of this amplifier are listed below:

1. 25 to 30 dB gain
2. Low noise figure
3. HMIC construction

The 25 to 30 dB gain raises the output power of the converter to a level which is the nominal input drive to the combiner. The HMIC construction affords continuity between the mixer and the amplifier.

The amplifier employed, the T-474-1A, is a two-stage broadband amplifier assembled on an alumina substrate. The amplifier provides 25 to 30 dB gain at 700 MHz with a 5 dB noise figure being typical. A frequency rolloff occurs near 700 MHz. This is compensated for externally to the X-band downconverter assembly. The amplifier is located between the mixer IF port and the IF output connector on the assembly.

## 2.3.2 700 MHz/X-Band Upconverter

### 2.3.2.1 Mixer

In order to frequency translate the 700 MHz IF signal from the combiner upconverter to the X-band transmit frequency, a mixer is required in the upconverter. The mixer must accept a 700 MHz signal and translate it to any frequency between 7.9 and 8.4 GHz by mixing with a local oscillator signal 700 MHz below it in frequency.

The upconverter mixer was designed in accordance with the same philosophy and procedures as the downconverter mixer, Paragraph 2.3.1.1.

Measurements of conversion loss over the operating frequency range and local oscillator drive level range varied from 9.5 to 11.5 dB.

### 2.3.2.2 Local Oscillator Filter

Band limiting is required in the local oscillator line to eliminate out-of-band frequency components which might produce in-band spurious outputs due to the action of the mixer.

The bandpass filter is identical to that in the downconverter except that the element lengths are shortened to accommodate operation across the local oscillator 500 MHz bandwidth centered at 7.45 GHz. Refer to 2.13.1 for the detailed design discussion.

### 2.3.2.3 Isolators

To provide the necessary isolation for the mixer RF and LO ports, isolators are used at those ports to provide a good load for the RF port of the mixer and prevent any reflected signals from propagating back to the mixer. An isolator is placed between the 15-pole bandpass filter and the RF mixer port. An isolator also is placed between the five-element bandpass filter and the local oscillator input port of the mixer. This isolator provides a good source VSWR at the mixer and prevents any signal from getting from the mixer into the local oscillator chain.

Isolators of the same type as used in the downconverter (Paragraph 2.3.1.3) are also used in the upconverter. Sonoma Model S-4543 is specified for the frequency range of

7.9 to 8.4 GHz and Model S-4423 is specified for the local oscillator frequencies of 7.2 to 7.7 GHz. The performance specifications are identical to those discussed in Paragraph 2.3.1.3.

The S-4423 was tested and found to meet all of its specifications. The S-4543 was 0.1 dB high in insertion loss and 2 dB low in isolation, but its performance was judged to be adequate for the application.

#### 2.3.2.4 15-Element RF Filter

To prevent the transmit noise power, which extends into the receive band, from getting into the receiver, a filter is required following the final upconversion and preceding the diplexer. Since the transmit band is so near the receive band, several elements of filtering are required.

In the interest of conserving weight and space, a photographically-reproduced filter network in an alumina thin-film construction was implemented in microstrip. Since a microstrip type of construction leaves the filter elements exposed and readily available and also does not require a ceramic cover to be uniformly bonded over the network, this construction was selected. Excessive stray field radiation is prevented by a closed conducting surface surrounding the filter.

The basic design philosophy of this filter is presented in the following paragraphs. This same philosophy also applies to other filters of similar construction used in the converters.

The filter design is started with the determination of the number of poles required in the filter to provide the required filter rejection response. Since the system has tight specifications on the amplitude flatness and phase linearity, it follows that a low-ripple prototype with a very wide passband should be used.

It is desirable to limit the classes of filter networks to be considered to those which may be readily manufactured using an alumina substrate. A parallel-line-coupled filter type has the advantage that no holes are required to be placed through the ceramic to allow grounding of the resonator elements as is the case of an interdigital type filter.

To prevent the problem that a higher-order mode of propagation may carry signal around the filter, the cross-section of the box is selected as a waveguide below cutoff.

Additional protection against multi-moding is provided by orienting the resonator elements at an angle in the container such that the axis of the quasi-TEM mode of propagation is oblique to the plane of the E-field of the  $TE_{mn}$  modes.

A network synthesis design procedure is used to develop these filters. The low-frequency normalized "g" values are calculated first. These are then used to construct the admittance matrix for the network.

Using the admittance matrix requires that the equivalent impedance matrix be calculated with odd- and even-mode propagation assumed. Finally, these odd- and even-mode impedances are related to the physical dimensions required to produce the filter.

For this particular filter, the network synthesis procedure described above was followed for a lowpass prototype having:

$$\text{Number of Poles} = 15$$

$$\text{Passband Ripple} = 0.10 \text{ dB}$$

From the normalized lowpass prototype "g" values, the admittance matrix and then the impedance matrix were calculated for:

$$\text{Bandwidth} = W = 8 \text{ percent}$$

$$Z_0 = 50 \text{ ohms}$$

$$Y_0 = 1/50 = 0.020$$

Having gone through all of the matrix manipulations, the necessary odd- and even-mode impedances were determined. It then remained to relate these impedance values to a suitable physical geometry. Based on a substrate thickness of 0.050 inches, a geometry was obtained which is shown in Figure 2.3-5.

The resulting filter was constructed, and the resulting amplitude response is shown in Figure 2.3-6. Refer to 2.13.2 for the detailed design discussion.

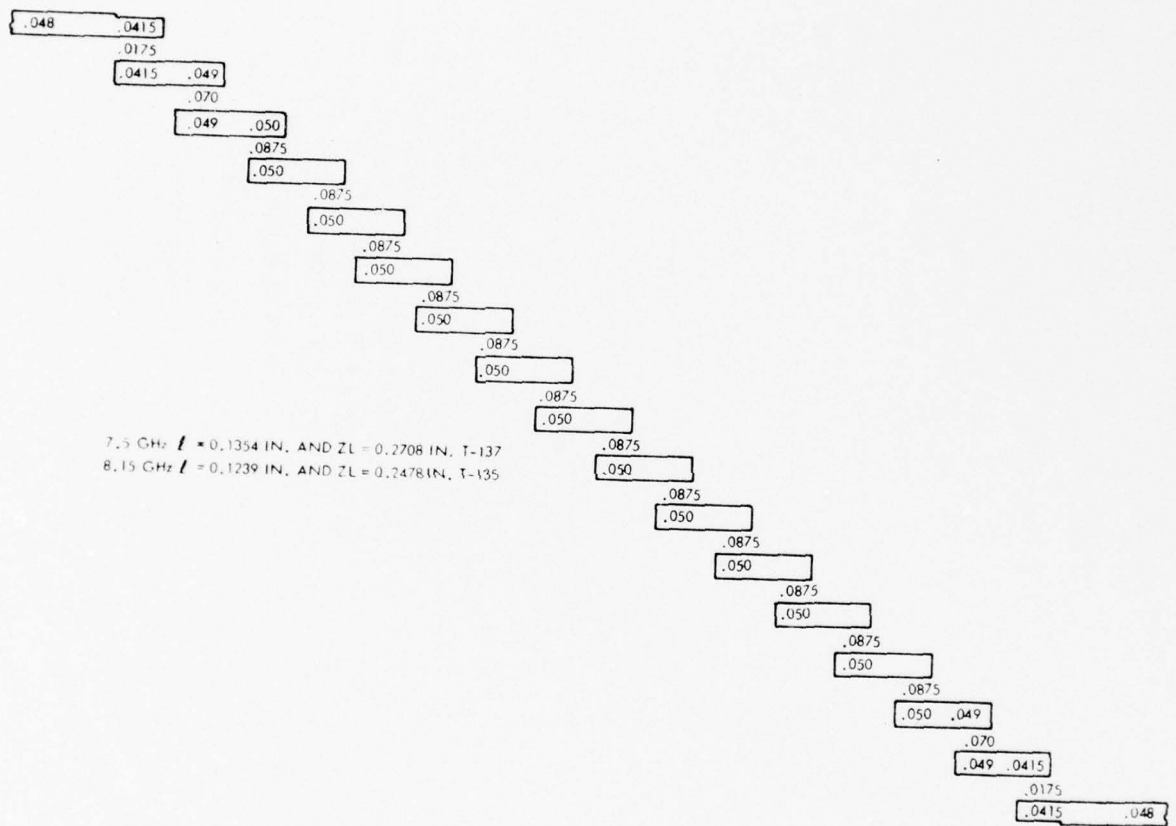

Figure 2.3-5. 15-Element Filter Geometry

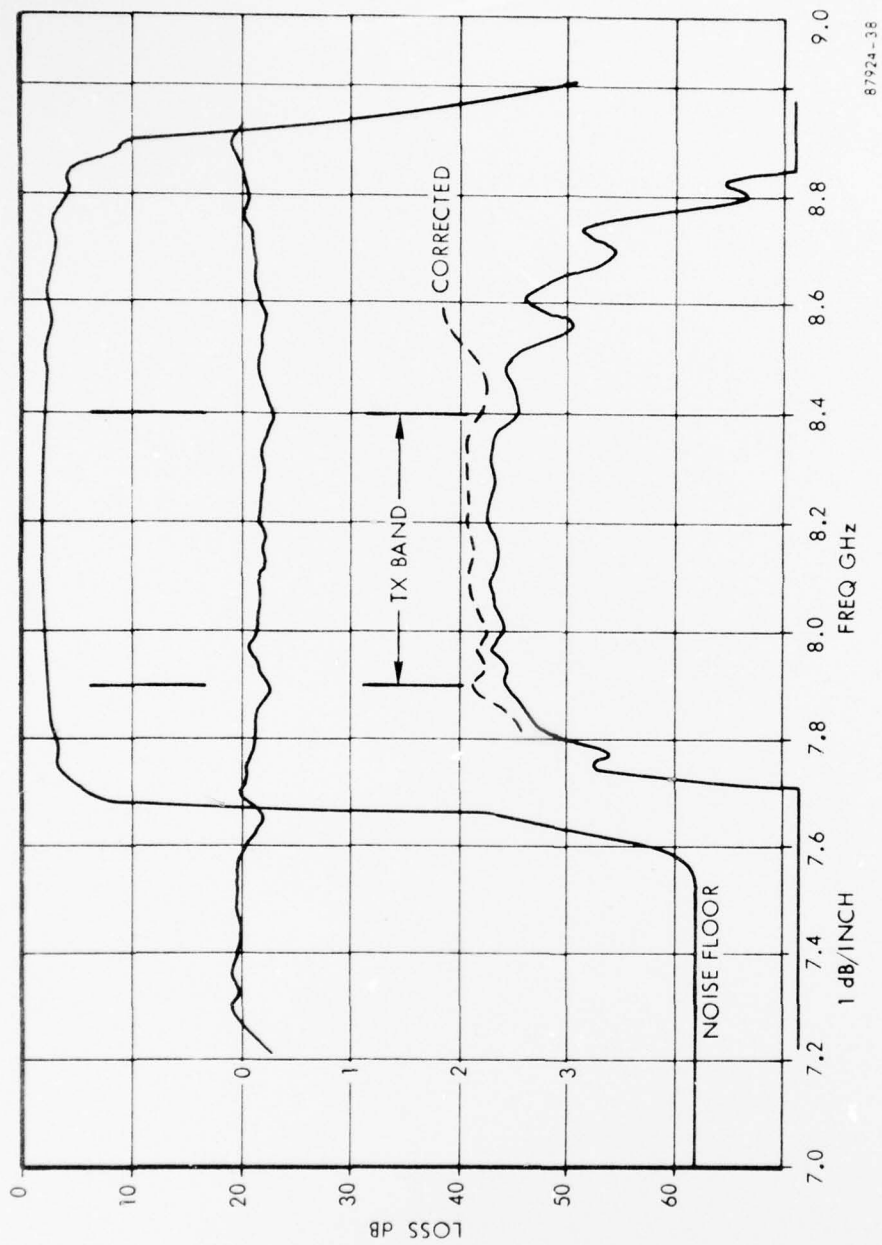

Figure 2.3-6. 15-Element SST 154 Bandpass Filter Frequency Response Curve With Compensation

### 2.3.3 X-Band/700 MHz Downconverter and 700 MHz/X-Band Upconverter Test Results

When the program direction was changed to single-aperture operation, three downconverter and three upconverter modules became residual spares. These were acceptance-tested separately from the converter drawers. Since extensive performance data were obtained on these units, a sample is presented herein, for one each of the up- and downconverter modules. Arbitrarily, Serial Number 2 of each has been selected for presentation.

Test setups are not shown but general information pertaining to test setups is included in Section 3 of this report. More specific information will be furnished upon request.

#### 2.3.3.1 Downconverter Test Results

##### 2.3.3.1.1 Amplitude Flatness

Four photographs were taken, each covering approximately a 150 MHz segment of the 500 MHz receive band, Figures 2.3-7 through 2.3-10. The vertical scale is 2 dB/cm, and the horizontal scale is 20 MHz/cm.

##### 2.3.3.1.2 Differential Time Delay

Five photographs were taken each covering a 125 MHz segment of the 500 MHz receive band, Figures 2.3-11 through 2.3-15. The vertical scale is 1 ns/cm, and the horizontal scale is 12.5 MHz/cm.

##### 2.3.3.1.3 Noise Figure

The noise figure was measured at five frequencies across the band. The results are tabulated below:

Figures 2.3-7 Through 2.3-10. Downconverter Amplitude Flatness

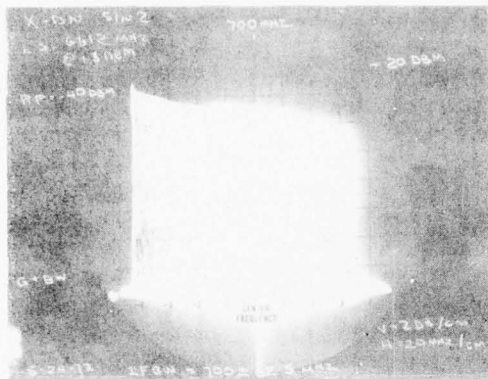

Figure 2.3-7

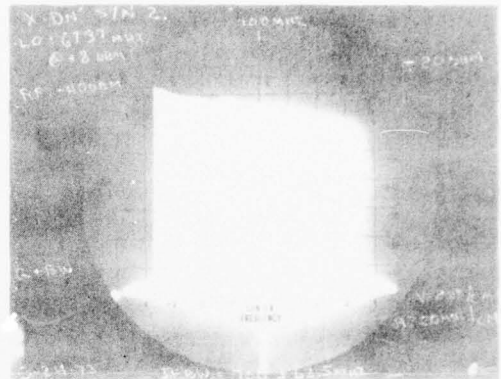

Figure 2.3-8

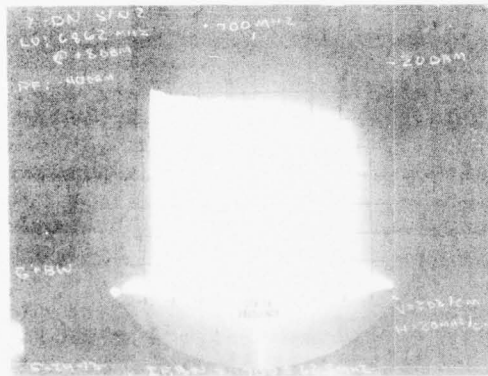

Figure 2.3-9

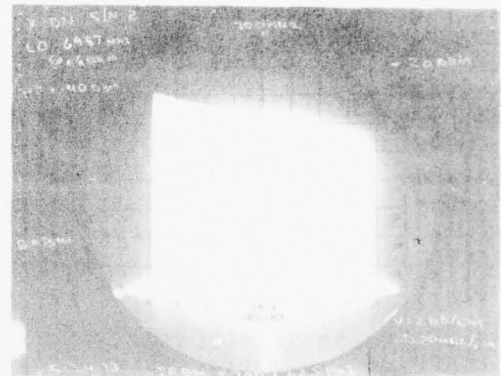

Figure 2.3-10

87924-39

Figures 2.3-11 Through 2.3-15. Downconverter Differential Time Delay

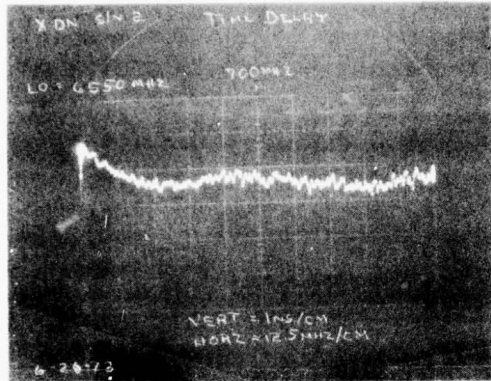

Figure 2.3-11

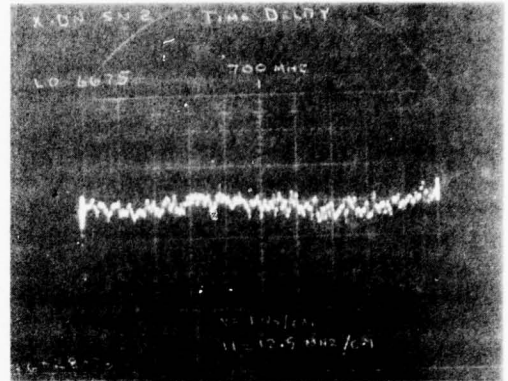

Figure 2.3-12

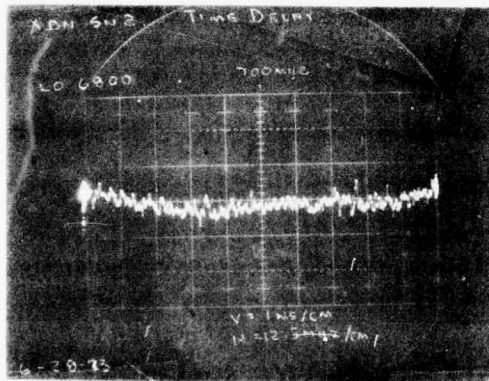

Figure 2.3-13

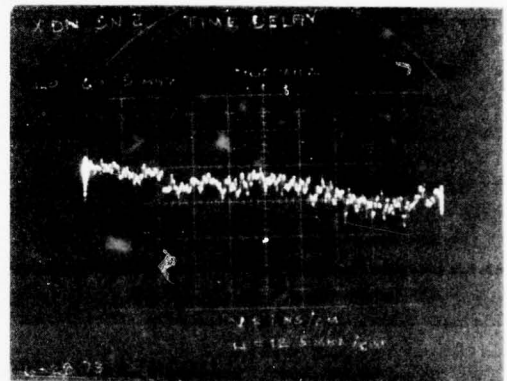

Figure 2.3-14

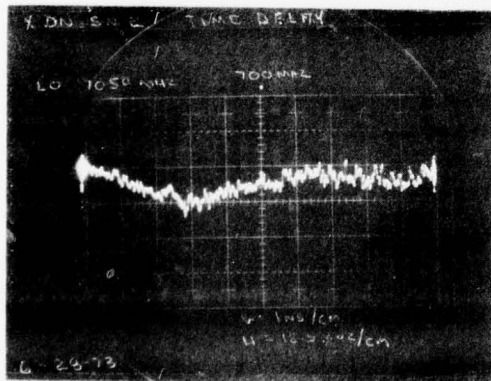

Figure 2.3-15

87924-40

*Albermar*

LO Frequency (MHz)	Receive Frequency (MHz)	Noise Figure	
		Measured (dB)	Corrected* (dB)
6550	7250	11.5	10.5
6675	7375	11.6	10.6
6800	7500	11.5	10.5
6925	7625	11.7	10.7
7050	7750	12.3	11.3

### 2.3.3.2 Upconverter Test Results

#### 2.3.3.2.1 Amplitude Flatness

Four photographs were taken, each covering approximately a 125 MHz segment of the 500 MHz transmit band, Figures 2.3-16 through 2.3-19. The vertical scale is 2 dB/cm, and the horizontal scale is 20 MHz/cm.

#### 2.3.3.2.2 Differential Time Delay

Five photographs were taken, each covering a 125 MHz segment of the 500 MHz transmit band, Figures 2.3-20 through 2.3-24. The vertical scale is 1 ns/cm, and the horizontal scale is 12.5 MHz/cm.

\* Corrected for 1.0 dB insertion loss of filter placed between noise source and downconverter input.

Figures 2.3-16 Through 2.3-19. Upconverter Amplitude Flatness

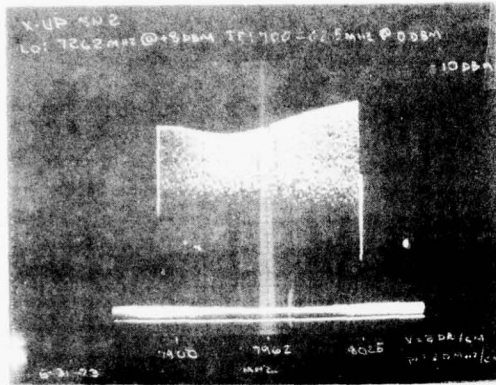

Figure 2.3-16

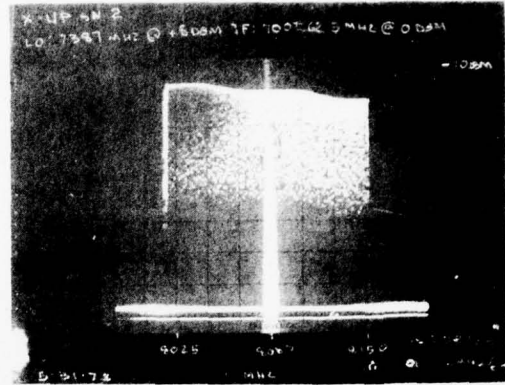

Figure 2.3-17

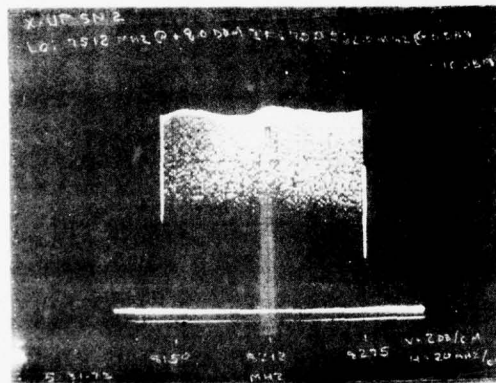

Figure 2.3-18

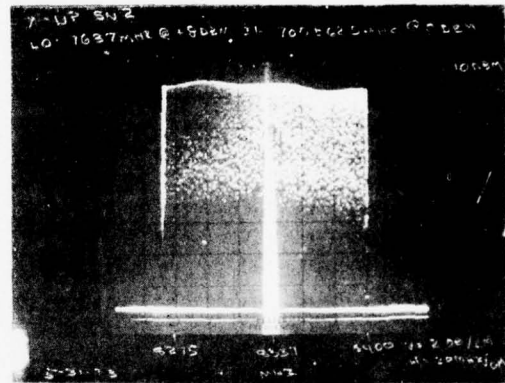

Figure 2.3-19

87924-41

Figures 2.3-20 Through 2.3-24. Upconverter Differential Time Delay

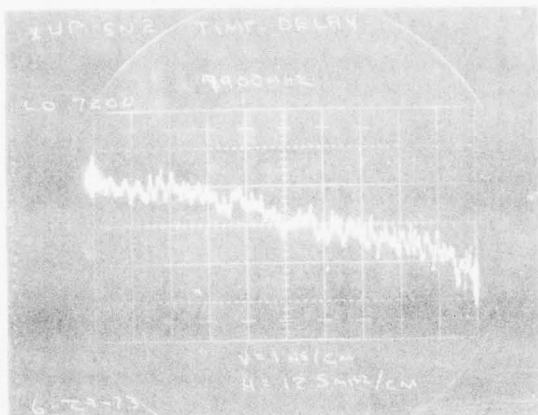

Figure 2.3-20

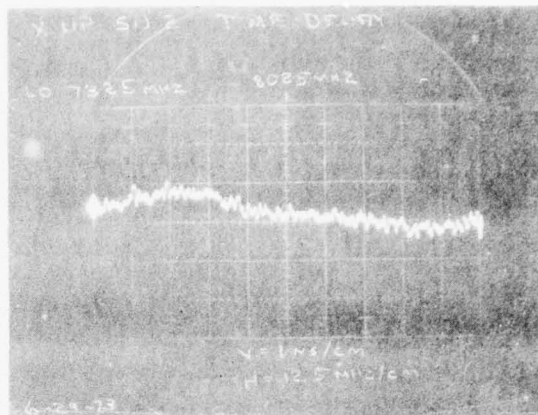

Figure 2.3-21

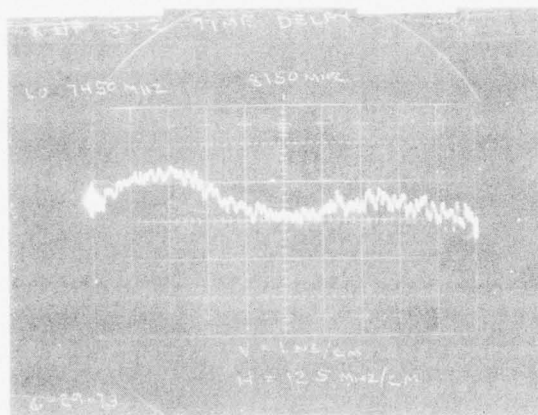

Figure 2.3-22

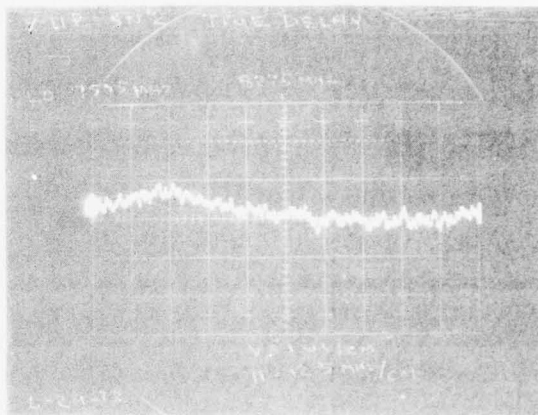

Figure 2.3-23

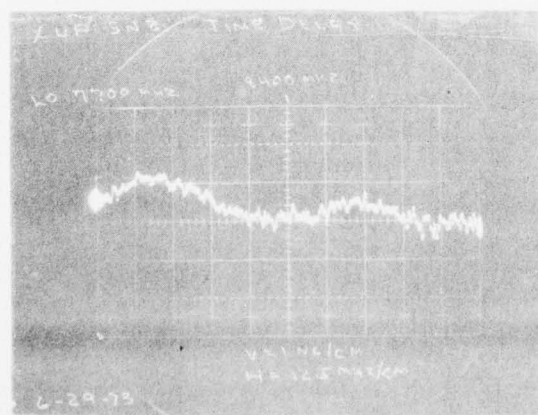

Figure 2.3-24

87924-42

## 2.4 5 MHz Oscillator

The 5 MHz oscillator is the frequency standard for the entire system. It provides a reference for all of local oscillator signals listed below:

1. Upconverter synthesizer
2. Downconverter synthesizer
3. 630 MHz fixed-frequency multiplier

The standard, located in the downconverter drawer, is patched to the upconverter through cables at the rear of the drawers.

The 5 MHz standard was purchased. It is Hewlett-Packard Model 10543A, and it satisfies the following specifications:

- |   |  |
|---|--|
| 1. Frequency:   | 5 MHz  |
| 2. Output voltage:  | 1 V $\pm 10\%$ rms   |
| 3. Impedance:   | 50 ohms  |
| 4. Stability:   | $< 5 \times 10^{-10}$ /day<br>$< 1.5 \times 10^{-7}$ /year |
| 5. Temperature, $-55^{\circ}\text{C}$<br>to $+71^{\circ}\text{C}$ : | $< 5 \times 10^{-9}$                                       |
| 6. Warmup   | 30 minutes   |
| 7. SSB phase noise ratio:   | 120 dB at 10 Hz offset (1 Hz BW)                           |
| 8. Frequency adjustment:  | $> 5 \times 10^{-7}$                                       |

## 2.5 VHF Synthesizer

In order to provide a tunable, stable local oscillator signal for the X-band/700 MHz downconverter and the 700 MHz/X-band upconverter, a VHF synthesizer is employed. The synthesizer must cover the frequency range of 131 to 141 MHz for the receiver and 144 to 154 MHz for the transmitter in 10 kHz steps so that a 500 kHz step capability is achieved at X-band after multiplication by 50.

The synthesizer, as shown in Figure 2.5-1, is functionally organized into three loops. The coarse loop tunes 80-142 MHz in 2 MHz steps; the fine loop tunes 10-12 MHz in 10 kHz steps. A summing loop combines the two giving an output tuning 90-154 MHz in 10 kHz steps. The coarse and fine loops are fabricated on three printed circuit cards each; the summing loop has two. In addition, there is a 5 MHz distribution amplifier printed circuit card for distributing the system standard to the coarse and fine loops.

The technique used in this synthesizer for generating coarse and fine loop signals is indirect synthesis. Referring to Figure 2.5-2, the output of a voltage-controlled oscillator at frequency  $f_{out}$  provides the output signal and also feeds a variable-ratio divider,  $\div N$ , giving an output with a frequency of  $f_{out}/N$ . This is phase-compared with a reference frequency  $f_r = \frac{f_s}{R}$ , obtained by frequency dividing the output of a standard oscillator with the reference divider,  $\div R$ . The error signal obtained is used to control the VCO after filtering to establish desired loop parameters. In the locked condition,

$$\frac{f_{out}}{N} = \frac{f_s}{R} = f_r$$

or

$$f_{out} = N \times f_r$$

Thus, the output frequency is an integral multiple,  $N$ , of the reference frequency  $f_r$ .

The signals from the coarse and fine loop are phase-locked in the summing loop and the error signal developed is used to control a VCO which is amplified and leveled to give the synthesizer output.

As discussed previously, the synthesizer is organized into a coarse loop, a fine loop and a summing loop. As shown in Figure 2.5-3, the coarse and fine loops each have an RF card, an analog card and a program divider card. The summing loop has an RF card and an analog card. Additionally, there is a 5 MHz distribution amplifier to supply the station standard signal to the coarse and fine loops. The designs of the individual cards are discussed in the following paragraphs.

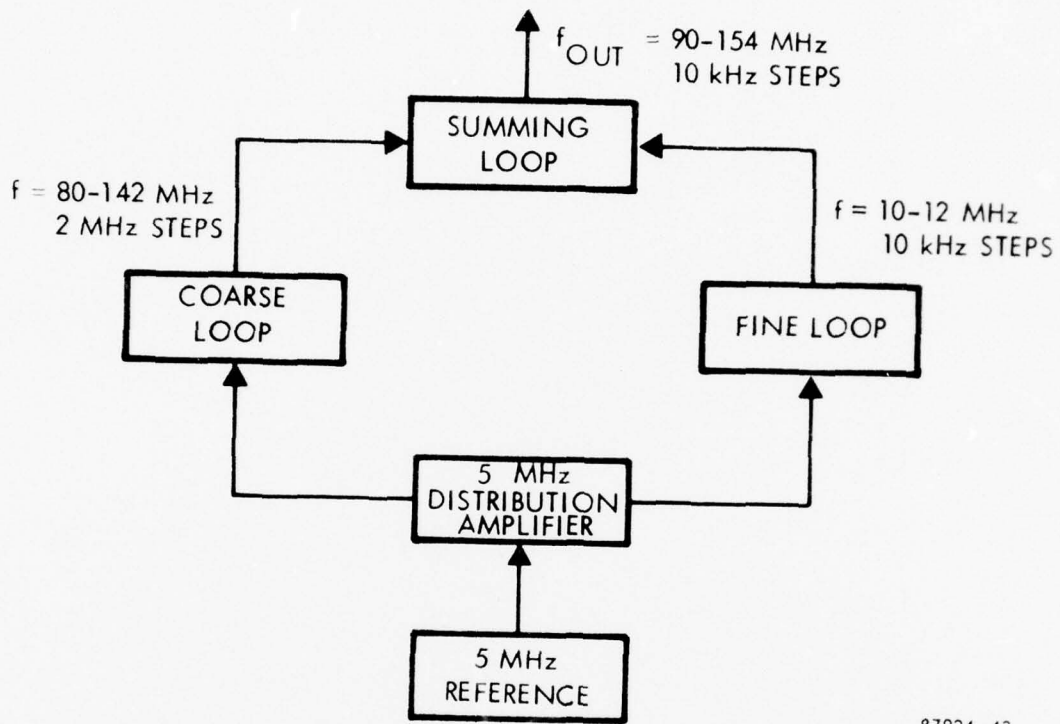

87924-43

Figure 2.5-1. Synthesizer Functional Block Diagram

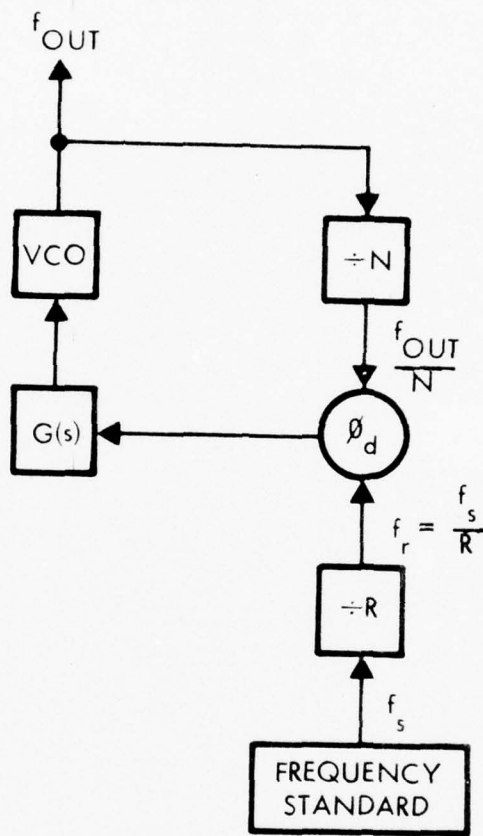

87924-44

Figure 2.5-2. Indirect Frequency Synthesis

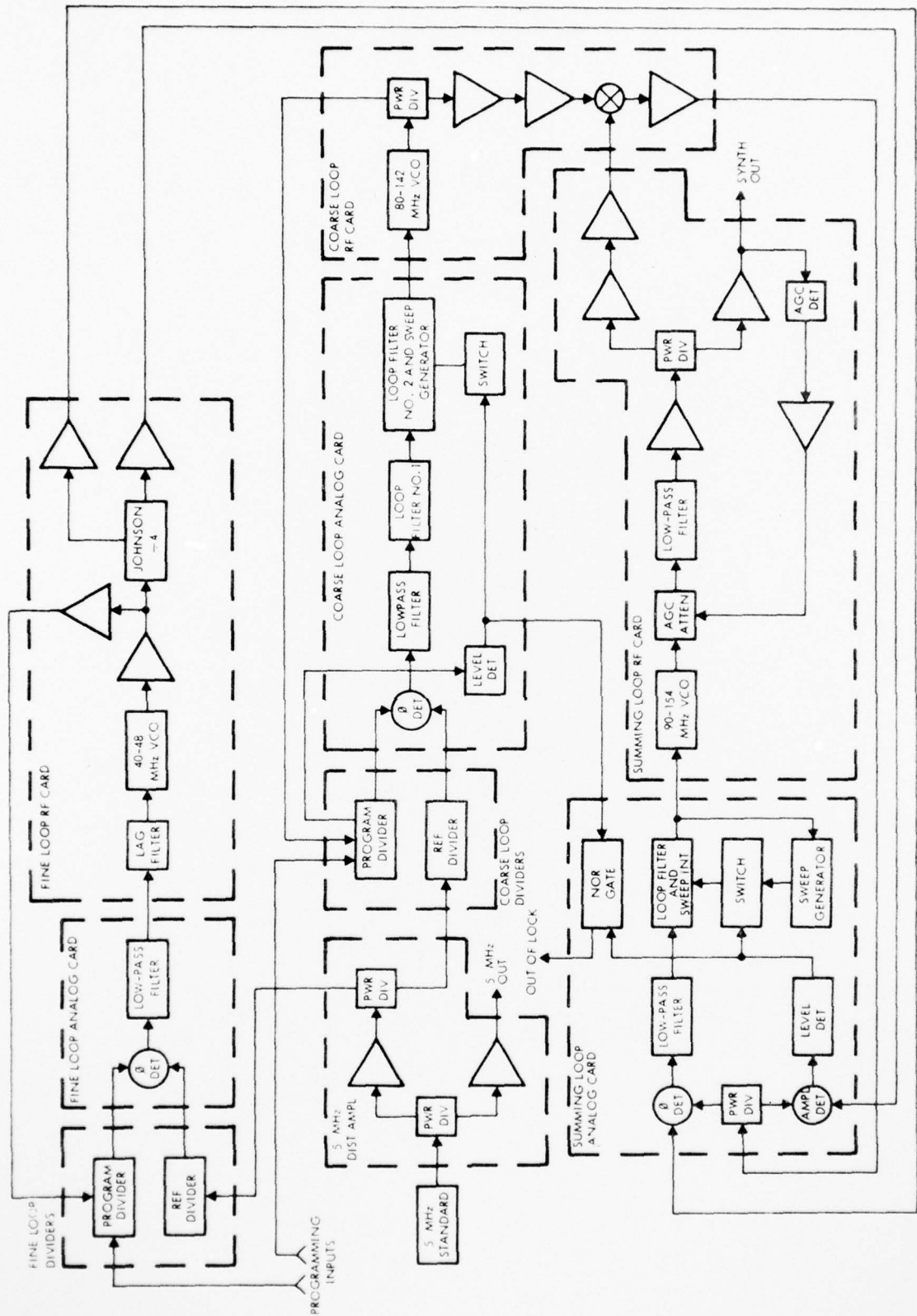

Figure 2.5-3. VHF Synthesizer Block Diagram

### 2.5.1 Summing Loop RF Card

The summing loop RF card accepts a control signal from the summing loop analog card which is used to tune a VCO. The VCO output is passed through a variable attenuator, a lowpass filter, and a buffer amplifier, then split by a 3-dB hybrid. One output is amplified for use on the coarse loop RF card; the other is amplified and passes through an automatic gain control detector before going to J7 as the synthesizer output. The AGC detector output is amplified and used to control the variable attenuator previously mentioned.

### 2.5.2 Summing Loop Analog Card

The summing loop analog card has two functions. In addition to performing a phase comparison between 10 MHz outputs of the coarse and fine loops to derive an error signal for VCO control, it makes amplitude comparisons for determination of phase-lock.

A 10 MHz signal from the fine loop RF card is compared in the phase detector with a reference signal from a power divider which obtains its input from the coarse loop RF card. The error signal is lowpass filtered, passed through the loop filter and is used to control the VCO or the summing loop RF card.

A 10 MHz signal from the fine loop RF card is compared in a detector with a reference signal from the power divider. A level detector senses out-of-lock condition and gives out-of-lock indication in addition to switching in the sweep generator and integrator combined in the loop filter previously mentioned. When lock is obtained, the sweep signal is removed.

### 2.5.3 Coarse Loop RF Card

The coarse loop RF card uses an error signal from the coarse loop analog card to control a VCO tuning 80 to 142 MHz. A power divider splits the VCO output for use on the program divider card, and an amplifier string boosts the output signal and provides isolation for feeding a mixer, the other input of which is the summing loop RF card output tuning 90 to 154 MHz. The resulting 10 MHz product is filtered and amplified to feed the power divider on the summing loop analog card.

#### 2.5.4 Coarse Loop Analog Card

The coarse loop analog card compares the phases of two 0.5 MHz signals from the coarse loop divider card and generates an error signal which is lowpass filtered and processed by the loop filters to establish loop parameters and sent to the coarse loop RF card for control of the coarse loop VCO. If the level detector connected to the program divider detects loss of lock, a sweep generator is enabled to obtain lock.

#### 2.5.5 Coarse Loop Divider Card

The coarse loop divider card frequency divides the 5 MHz reference by 10 to get the 0.5 MHz reference for the coarse loop analog card. The program divider divides the frequency of the VCO down to 0.5 MHz and gives an out-of-lock indication when necessary to start the sweep.

#### 2.5.6 Fine Loop RF Card

The fine loop RF card has two outputs at 10-12 MHz and one at 40-48 MHz. The 40-48 MHz for the program signal is obtained by splitting the output of the VCO. The other VCO output feeds a Johnson counter  $\div 4$  circuit to give a 10-12 MHz signal which is split and buffered for use in the summing loop analog card. The filter for establishment of loop parameters is included on the RF card.

#### 2.5.7 Fine Loop Analog Card

The fine loop analog card has a phase detector for comparison of a 40 kHz reference signal with a 40 kHz signal from the program divider. The resultant error signal is lowpass filtered before passing to the fine loop RF card.

#### 2.5.8 Fine Loop Divider Card

The fine loop divider card has a programmable divider for frequency dividing the fine loop VCO output and a reference divider ( $\div 125$ ) for obtaining a 40 kHz reference signal from the 5 MHz standard.

AD-A038 512

HARRIS CORP MELBOURNE FLA ELECTRONIC SYSTEMS DIV  
DEVELOPMENT OF SOLID-STATE TRANSPORTABLE SATELLITE COMMUNICATIO--ETC(U)  
MAR 74

F/G 17/2  
DAAB07-72-C-0097  
NL

UNCLASSIFIED

2 OF 2  
AD  
A038512

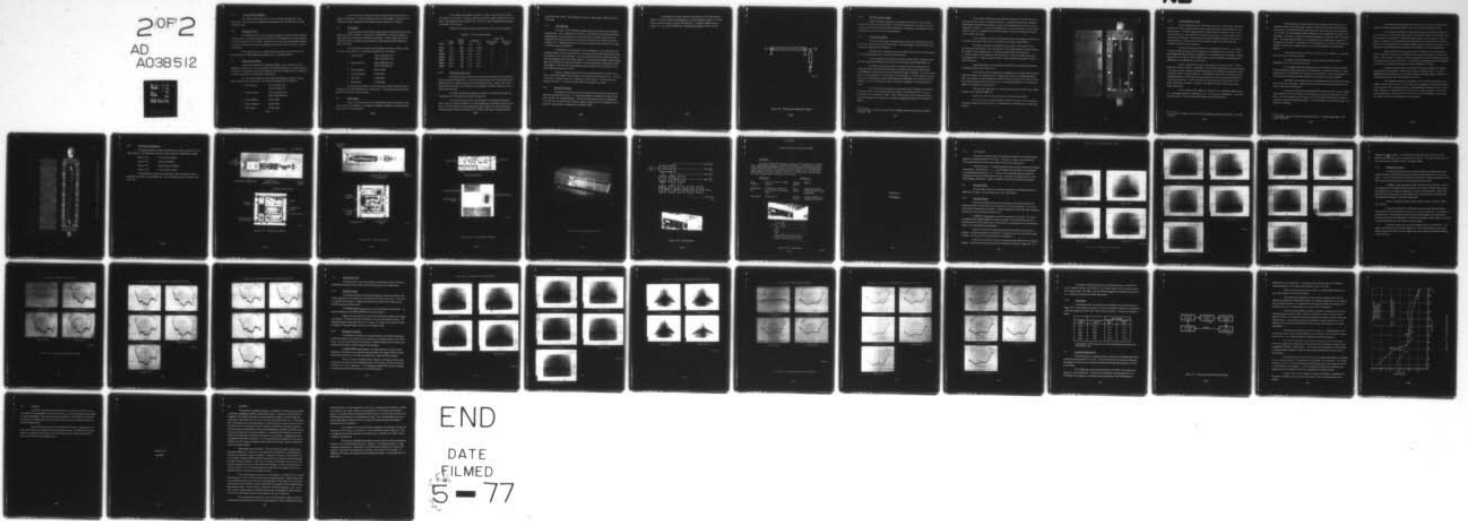

END

DATE  
FILMED  
5-77

### 2.5.9 5 MHz Distribution Amplifier

The 5 MHz standard input is split, with one arm going through a buffer to an output jack. The remaining arm is buffered and split again for use in the coarse and fine loop reference dividers.

### 2.6 Programming Circuit

The thumbwheel switch on the front panel indicates the incoming X-band frequency to the converter. The synthesizer requires a BCD code which corresponds to its output frequency of 131 to 141 MHz and 144 to 154 MHz. Therefore, a circuit containing programmable memories is required to change the code from the thumbwheel switch to one which will correctly command the synthesizer.

The programming card is a command-and-control logic circuit containing three Harris Semiconductor 8256 programmable memory dual-in-line packages (DIPs).

### 2.7 L-Band Agile Oscillator

In order to multiply the VHF synthesizer frequency up to a value which, when subsequently multiplied by 5 will give the proper local oscillator frequency, an L-band oscillator is employed. The oscillator must be able to frequency track the VHF signal which is injected into it and provide an effective X10 frequency multiplication.

The L-band agile oscillator was purchased from Engelmann Microwave Company, Model Numbers FA-A17 and FA-A18. The oscillator specifications are listed below:

1. Input frequency:                    131 to 141 MHz (D/C)  
    144 to 154 MHz (U/C)
2. Output frequency:                   1310 to 1410 MHz (D/C)  
    1440 to 1540 MHz (U/C)
3. Input impedance:                    50 ohms (both)
4. Output impedance:                   50 ohms (both)
5. Output power:                        +23 dBm (both)

Since the oscillator is injection-locked to the synthesizer and provides a 10-1 frequency multiplication, its output is coherent with the 5 MHz standard. The output of the L-band source feeds the appropriate X5 multiplier through an attenuator for isolation.

## 2.8 X5 Multiplier

In order to obtain a local oscillator output frequency 700 MHz below the receive frequency of 7250 to 7750 MHz in the receiver or 700 MHz below the transmit frequency of 7900 to 8400 MHz, X5 frequency multipliers are employed. An input frequency of 1310 to 1410 MHz or 1440 to 1540 MHz must be translated to a band between 6550 to 7050 MHz or 7200 to 7700 MHz.

The X5 multiplier was purchased from Engelmann Microwave Company, Model No. MX-A-4 and MX-A-5. The multiplier specifications are listed below:

1. Input frequency:                   1310 to 1410 MHz (D/C)  
  1440 to 1540 MHz (U/C)
2. Output frequency:                6550 to 7050 MHz (D/C)  
  7200 to 7700 MHz (U/C)
3. Input impedance:                 50 ohms (both)
4. Output impedance:                50 ohms (both)
5. Input power:                       +3 dBm (both)
6. Output power:                     +13 dBm (both)

The output of the multiplier at the local oscillator frequency passes through an attenuator to the X-band/700 MHz up- or downconverter. The attenuator provides isolation between the multiplier and the converter.

## 2.9 Power Supplies

To allow the converter drawers to be self-sufficient except for ac power, they require internal power supplies. Six separate dc voltages are employed in the downconverter drawer and five in the upconverter.

Very compact power supplies are required in order to keep the size and weight of the drawers to a minimum. Acopian was selected as the power supply vendor primarily on the basis of the compactness of their modular units. Each unit is epoxy-encapsulated and occupies no more than 10 cubic inches.

Table 2.9 lists the power supplies and shows how many are used in each drawer.

Table 2.9. Converter Power Supplies

Model	Voltage (vdc)	Current Rating (mA)	Regulation		Number Used	
			Load	Line	Downconverter Drawer	Upconverter Drawer
5E100	-5.2	1000	0.2%	0.05%	1	1
5E150	+5.0	1500	0.3%	0.1%	1	1
15E020	-15.0	200	0.1%	0.1%	1	1
15E060	+15.0	600	0.1%	0.1%	1	1
20E040	+20.0	400	0.1%	0.1%	1	1
24E010	+24.0	100	0.1%	0.1%	-	1
24E035	+24.0	350	0.1%	0.1%	1	1

#### 2.10 Out-of-Lock Circuit Card

The proper operation of each of the converter drawers depend on the functioning of the two phase-lock loops therein. The VHF synthesizer relies on the 5 MHz standard for its phase-lock and the L-band agile oscillator on the synthesizer output. Should either or both drop lock for some reason, it would be of aid to the operator to be able to observe this with a light on the front panel.

The light on the front panel labeled "out-of-lock" illuminates when either the synthesizer or the L-band oscillator or both lose phase-lock.

The out-of-lock sensing circuit uses NOR logic to illuminate the light when either a logic zero from the synthesizer or a sweep voltage from the oscillator is present at the input. Since the Engelmann oscillator produces a sweep voltage in the unlocked condition, alternating highs and lows are produced at the NOR gate logic output, thereby causing the

out-of-lock light to blink. The synthesizer out-of-lock voltage causes a steady illumination of the light.

#### 2.11 630 MHz Filter

The mixer in the 70/700 MHz combiner upconverter produces 560 and 700 MHz mixing products. Due to imperfections in the mixer, a small amount of these 560 and 700 MHz signals appear at the local oscillator port of the mixer and are coupled to the FFM module, through the FFM 3-way power divider, to the local oscillator port of the 700/70 MHz down-converter mixer. Imperfect balance in that mixer then can permit these signals to be translated to 70 MHz, producing interference.

This possibility was considered in the initial design but it was concluded that the combined isolation of the two mixers and the 3-way power divider would be high enough so that the interference would be insignificant. Thus, no provisions were made for additional isolation. When the equipment was built and tested, however, it was found that the 560 and 700 MHz leakage on the 630 MHz line, particularly 560 MHz, were large enough to cause potential interference problems. The main cause of the problem was poor isolation in the 3-way power divider due to high out-of-band source VSWR.

To prevent leakage at 560 and 700 MHz from escaping from the combiner upconverter, a 630 MHz bandpass filter was added in the upconverter local oscillator line. This filter is of stripline interdigital design and is fabricated on duroid material. It has four poles and 4 percent bandwidth. It is similar to the 630 MHz filter employed in the FFM.

#### 2.12 Equalization Network

The performance of the up- and downconverters relies heavily on the end-to-end amplitude and group delay flatness. It is sometimes necessary to compensate for amplitude and delay variations in an integrated system. Although the upconverter required no compensation in its final form, the downconverter frequency response dictated the use of an equalizer to compensate for a gain slope in its passband due to amplifier rolloff.

The equalization network consists of a two-stub tuner with the 50-ohm shunt element's electrical length being adjustable with a variable capacitor to ground. The series element consists of a specific length of RG-223 cable. A schematic diagram is shown in Figure 2.12. Test results indicated that a 3-dB slope was equalized to within  $\pm 0.5$  dB.

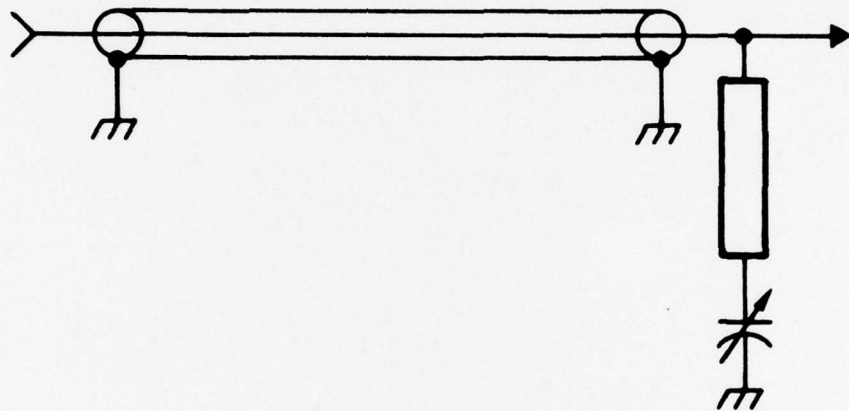

87924-46

Figure 2.12. 700 MHz Gain Equalization Network

## 2.13 SHF Filter Network Designs

One of the program objectives was to determine the extent to which microwave thin-film filter networks might be utilized. Three filter requirements in the system, the transmit and receive filter networks and the local oscillator band-limiting filters, were selected as ideal candidates to use for thin-film filter network designs.

### 2.13.1 Local Oscillator Filters

The local oscillator signal is developed in this system as an L-band oscillator signal, which is phase locked to the VHF synthesizer. This L-band signal is then multiplied by four to derive the required injection frequency.

A bandpass filter is required in the local oscillator line to select the fourth harmonic of the multiplication and reject the third and fifth harmonics.

Two filter designs were computed for the local oscillator bands: the receive local oscillator signal (6550-7050 MHz) and the transmit local oscillator signal (7200-7700 MHz).

The number of resonators required in the design for the receive band filter was computed by setting the 60-dB bandwidth equal to the spacing of the third and fifth harmonic lines (2900 MHz) and the design nominal 0.5-dB bandwidth equal to 700 MHz. This skirt-to-nose ratio of 4.143 corresponds to a filter network with five resonators. A similar analysis of the transmit band filter requirements provides a 60-dB bandwidth of 3225 MHz and a 0.5-dB bandwidth of 700 MHz, or a skirt-to-nose ratio of 4.607, which again corresponds to a five-resonator filter network.

A low-frequency prototype network of five poles and 0.1 dB ripple was selected as the design baseline. Using standard synthesis techniques,<sup>1</sup> the admittance matrix  $J_0/V_0$  was calculated from the prototype "g" values. These values were then used to compute the odd and even mode impedances for coupled lines, assuming a homogeneous distribution of the dielectric medium.

---

<sup>1</sup> Jones, Matthaei, Young; "Microwave Filters, Impedance Matching Networks and Coupling Structures," 1964.

Several design configurations are theoretically feasible in a thin-film hybrid structure, and the choice involves a number of trade-offs. A careful examination of the candidates disclosed that the parallel-line-coupled array type has the advantage that no short circuits are required in the network. It also has the advantage that it may be constructed in a narrow walled enclosure, which is a waveguide beyond cutoff; therefore, the multimodal responses of the network are readily attenuated.

It now remained to convert the required odd and even mode impedance values to the line widths and resonator spacings which are equivalent to the design values desired.

This design calculation was obtained by using a Univac 1108 computer to do a point-by-point matching against an assumed solution of the voltage gradient in the space between the conductors and the housing walls. The software programs used were obtained from Dr. Jerald A. Weiss, Staff Consultant at MIT Laboratories, in a private communication dated 9 November 1972. Dr. Weiss's program, MSTRIP, was used to obtain family graphs of the W/H and S/H functions.

A graphical solution was interpolated from these plots and the resulting dimensions converted into filter network artwork masks.

The first group of filters designed were implemented on an alumina oxide substrate of 0.25 mil thickness, with a metallization of 150 Angstroms of chromium and 2500 Angstroms of gold. This substrate was then electroplated to 500 microinches of gold prior to etching the filters. These filters proved quite difficult to control due to the small gap (0.0045 inch) in the input and output circuit impedance inverter sections.

The filters were redesigned on an alumina substrate thickness of 50 mils which allows this gap to be increased to 0.0090 inch.

Figure 2.13-1 shows the test fixture used to characterize these filters.

The final version of each filter provides a flat loss in-band of 1 dB and rejection to the adjacent undesired harmonics of 45 dB. This performance is quite satisfactory for these filter networks.

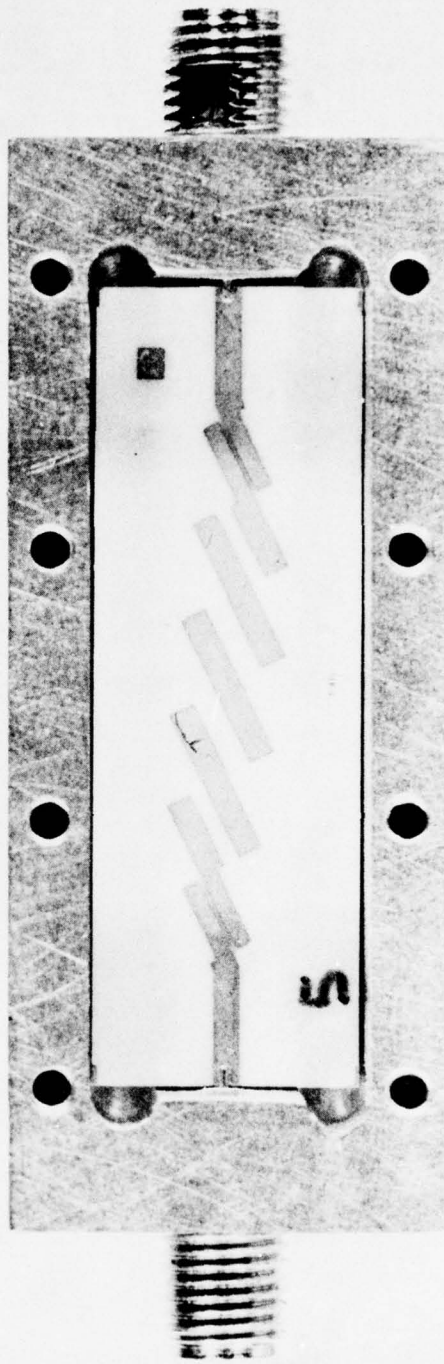
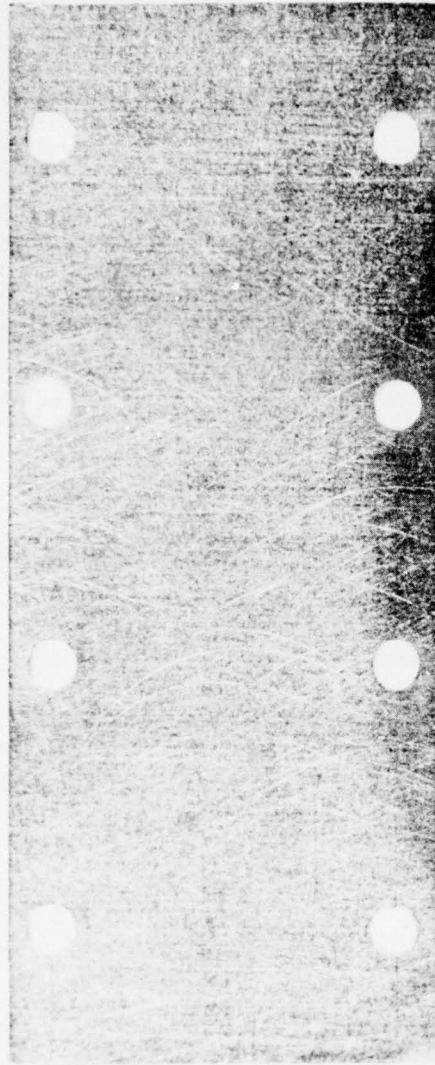

73-0461

Figure 2.13-1. Test Fixture for 5-Element Thin-Film Microwave Filter

### 2.13.2 Transmit and Receive Filters

The band-limiting required in SHF transmit and receive lines has been traditionally provided with various waveguide filter networks because of the low losses obtainable with waveguide resonators. The filter requirements for this terminal were first examined in terms of waveguide filter networks. But, because of the need for minimum size, other types of filter construction were also investigated. Among the other techniques examined are comb-line construction, balanced stripline on duroid, and thin-film microstrip on alumina, all of which offer the potential of smaller size than waveguide.

The first filter designs calculated were of waveguide construction. A conventional synthesis technique was used, and the computations were iterated with a Univac 1108. Twenty-eight separate detailed analyses were completed, for various bandwidths and numbers of resonators ranging from 10 through 15. These computed results were then available as a guideline of the performance that waveguide filters could provide.

A series of combline filters were computed using E. G. Cristal's work.<sup>2</sup> None of these filter networks, however, proved useful. The manufacturing tolerances which were obtained in the center-to-center spacing of the resonator elements were inadequate to satisfactorily control the adjacent element coupling coefficients. The breadboard filter networks were adjusted within reasonable performance limits using multiple tuning screws and various mechanical modifications of the resonator spacings. The filter flat loss was found excessive (3.5 dB typical), and the designs multimoded quite badly. In summary, the combline microwave filter networks were totally unsatisfactory.

A series of seven distinct designs was computed next in a balanced stripline construction. A homogeneous dielectric loading at an  $\epsilon_r = 2.12$  was used in these designs. To minimize the insertion loss, a 2-ounce rolled copper material was used in these filters.

---

<sup>2</sup> E. G. Cristal, "Coupled Circular Cylindrical Resonators Between Parallel Ground Planes," IEEE-MTT, July 1964.

The design difficulty associated with the very small gap of the input and output impedance inverters was prevented using J. Mosko's technique<sup>3</sup> of alternate series-mode impedance inverters. These filters generally performed poorly, with in-band flat losses ranging from 1.7 to 3.7 dB. The most undesirable quality observed was that a stagger-tuning occurred in all the designs, even though a compensation had been included for the expected value of the fringing fields. This stagger-tuning resulted in an unacceptable level of in-band ripple, ranging from  $\pm 0.50$  dB up to  $\pm 2.00$  dB. It is believed that the dimensional control of the circuits causes some problem, and the physical assembly tolerances in the package probably cause the resonator detuning.

A final alternate design of the transmit and receive filter networks was computed for an alumina oxide thin-film construction.

The design techniques followed the synthesis procedure outlined in detail in Paragraph 2.13.1 on the local oscillator filters.

Two prototype designs were computed, one with 15 elements, 8 percent bandwidth and 0.10 dB ripple, and the same design with 0.20 dB ripple. The physical realization of these filter networks was first realized with a substrate thickness of 25 mils. As one would expect, the etching control of the input and output impedance inverter gaps was a difficult problem.

These filters were remanufactured with a 50-mil substrate which eliminated the problem in the narrow line spacings. These thin-film substrate filter networks were extensively evaluated in their electrical performance.

The electrical performance testing identified the need to develop a network compensation system to correct for end effects in the transformers on the input and output sections of the filters. With the incorporation of this network, the in-band ripple of 0.90 dB peak-to-peak was successfully reduced to 0.20 dB peak-to-peak. A flat loss in-band of 2 to 2.5 dB was found to be typical for 15 elements.

---

<sup>3</sup> J. A. Mosko, "Design Technique of UHF Stripline Filters." NAWEPS Report 8677, NOTS tp 3731; AD 616995.

These filters demonstrated a good skirt-to-nose ratio, the ratio of the 45-dB bandwidth to the 10-dB bandwidth being 1.085, which is very close to the theoretical value.

It was noted in the evaluation of these filter designs that the physical height of the cover of the box, from the surface of the ceramic, had a first-order effect on the placement of the filter networks center frequency. Interestingly enough, though one would expect this type of behavior in general, it was surprising that this moving around of the filter networks' center frequency was not accompanied by any noticeable stagger-tuning of the individual resonators. Some value could conceivably be obtained by using the cover position as a fine tuning adjustment.

Figure 2.13-2 shows the test fixture used for evaluation of these 15-pole filters. The final design of the filter used in the 700 MHz/X-band upconverter module is mounted in the fixture. The two-element "L-networks" used to compensate the launcher transformers can be seen at the input and output points on this filter. The final electrical adjustment of the shunt element in this network was made with a diamond scribe under a 30-power microscope.

Though the alumina oxide thin-film filters were found to be generally satisfactory and potentially manufacturable - superior to the combline and stripline filters - they are not adequate for low-loss applications as in a receiver input or a transmitter output. (Note that the 15-pole prototype filters had in-band losses of 2 to 2.5 dB.)

The fundamental limitation is unloaded  $Q$ , which is limited to somewhat less than 1,000 in alumina oxide construction. On the other hand, unloaded  $Q$ 's on the order of 12,000 are quite practical with waveguide resonators, yielding passband and losses of a small fraction of a dB. Therefore, the waveguide filter will remain the only serious candidate for very critical low-loss applications, and the ceramic thin-film filter - for all its advantages - will be useful only where a relatively high passband loss can be tolerated.

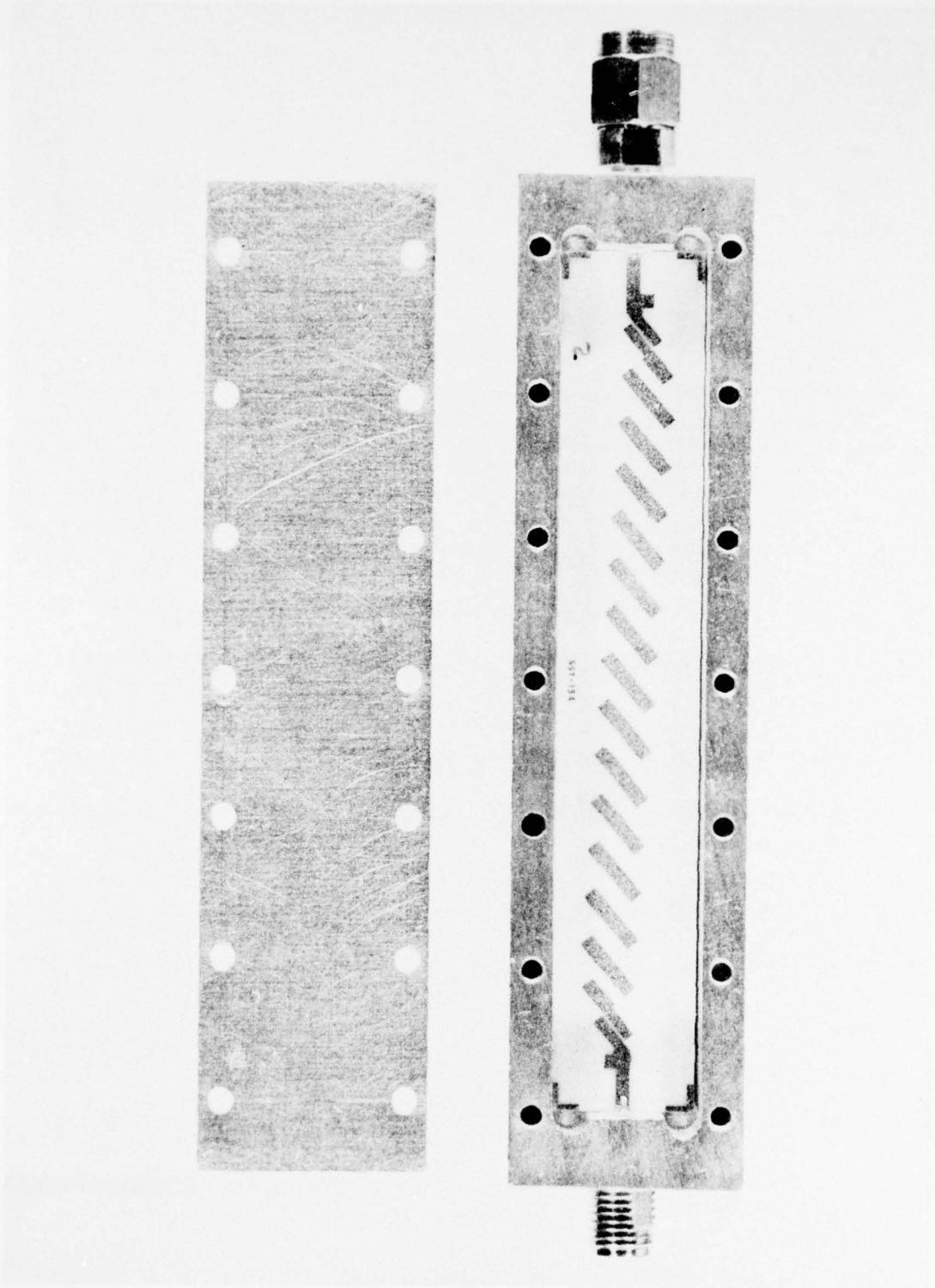

73-0459

Figure 2.13-2. Test Fixture for 15-Element Thin-Film Microwave Filter

## 2.14 Final Physical Configuration

The subsystem hardware elements developed on this program are shown with their covers removed. The listing below indicates the figure numbers for these hardware modules.

Figure 2.14-1	Downconverter Modules
Figure 2.14-2	Upconverter Modules
Figure 2.14-3	Fixed Frequency Multiplier
Figure 2.14-4	VHF Synthesizer Module

The final hardware configuration provides these subsystem hardware elements integrated into standard rack-mountable units. These converters are shown in Figures 2.14-5 and 2.14-6.

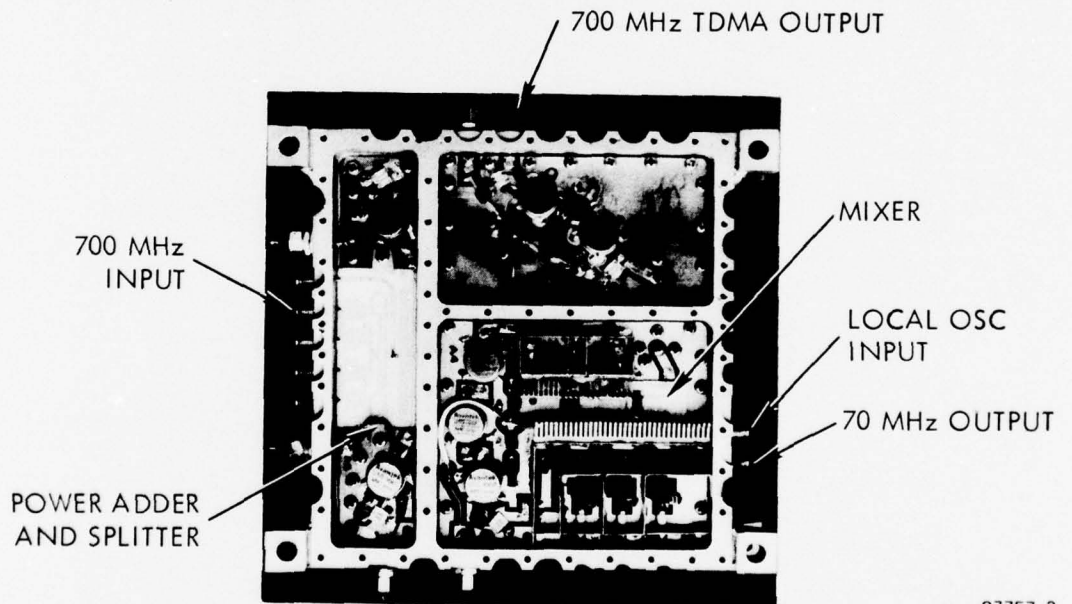
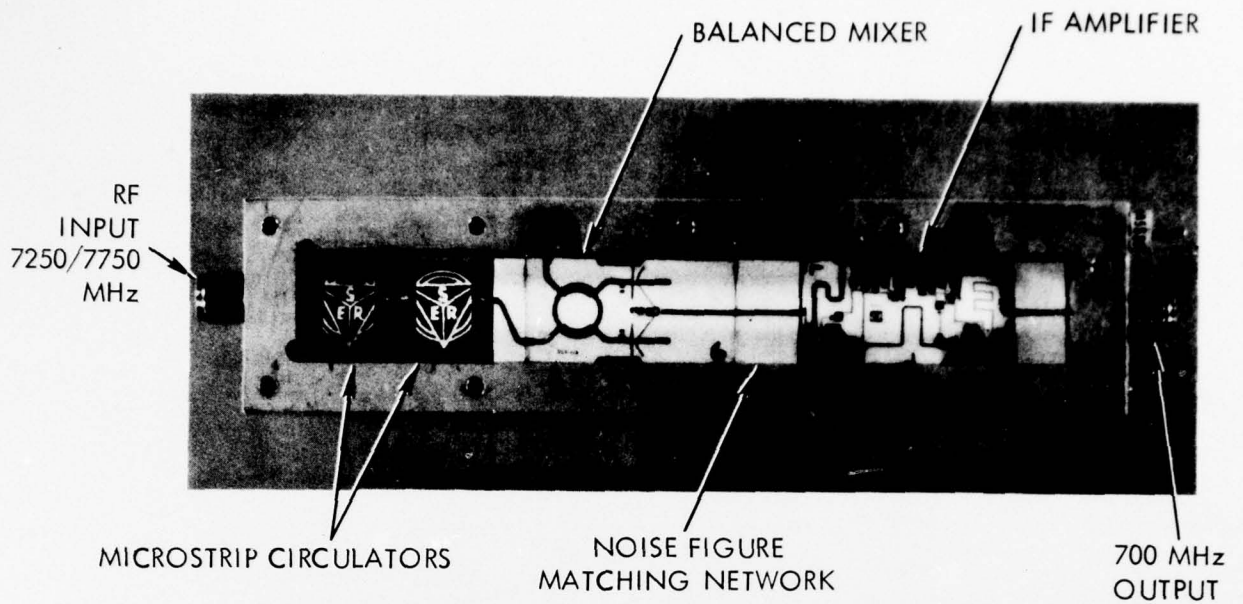

87757-3

Figure 2.14-1. Downconverter Modules

LOCAL OSC  
INPUT



7900-8400 MHz OUTPUT  
TO LOWER SIDE

700 MHz  
INPUT

700 MHz  
OUTPUTS

LOCAL OSC  
INPUT  
630 MHz

70 MHz INPUT

700 MHz INPUT  
TDMA

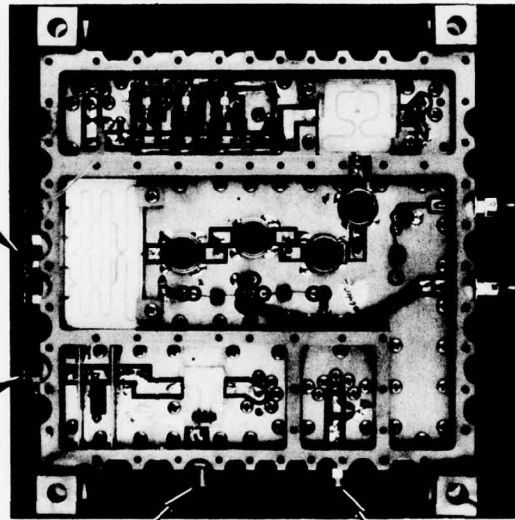

87757-4 A

Figure 2.14-2. Upconverter Modules

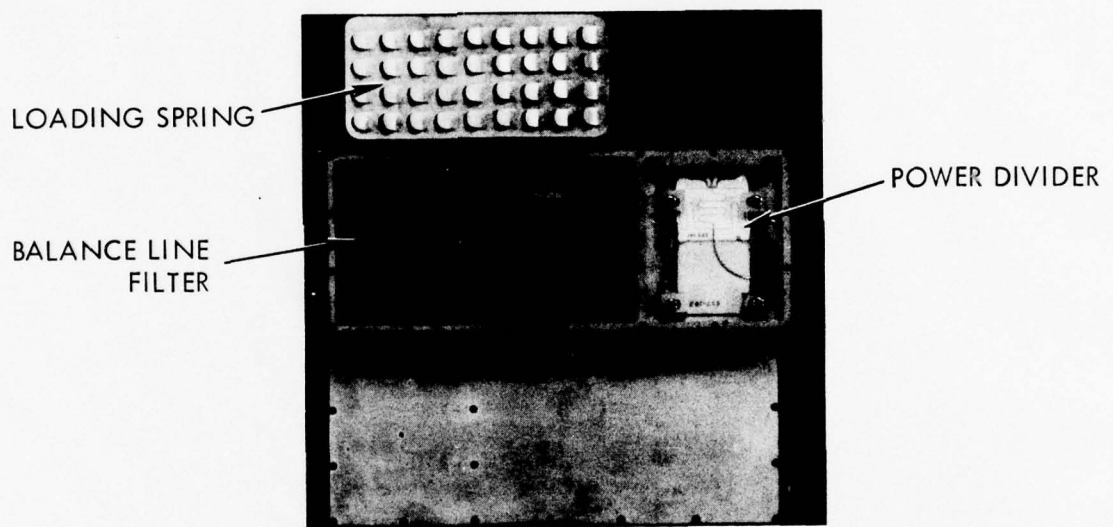
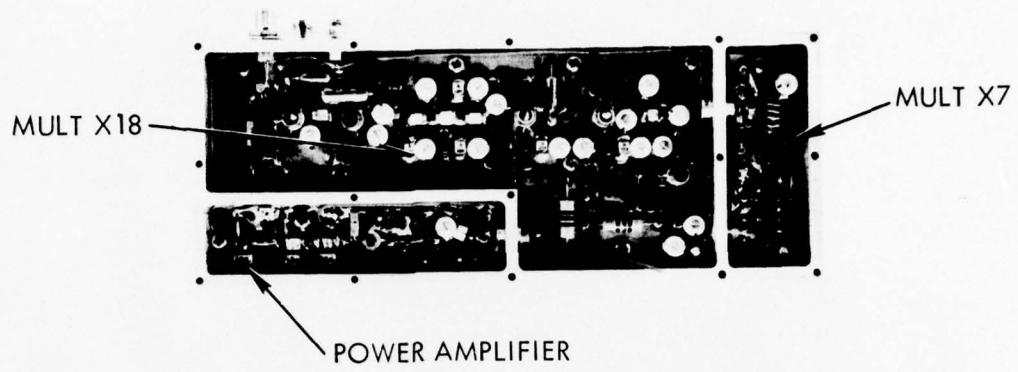

87757-5

Figure 2.14-3. Fixed Frequency Multiplier

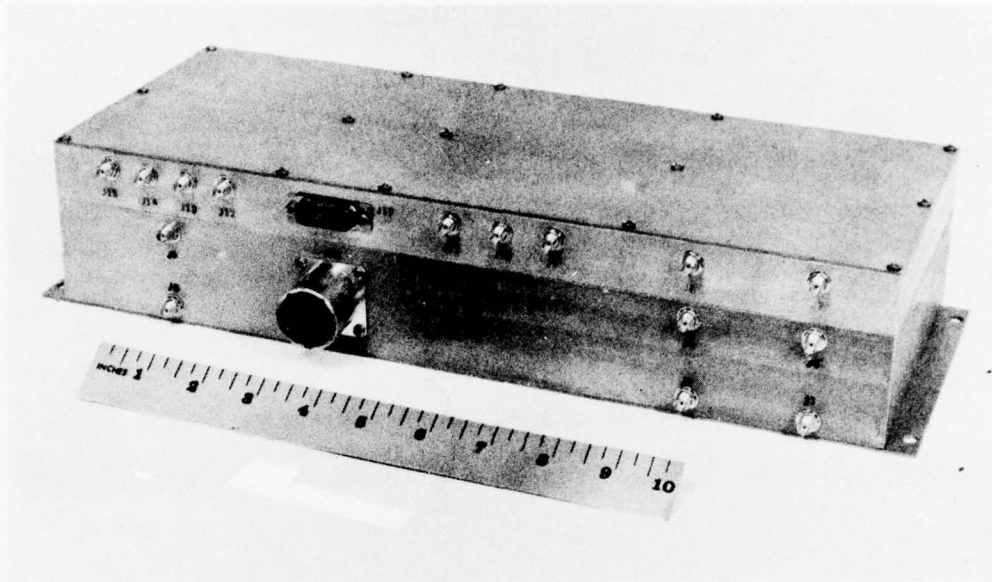

87283-2

Figure 2.14-4. VHF Synthesizer Module

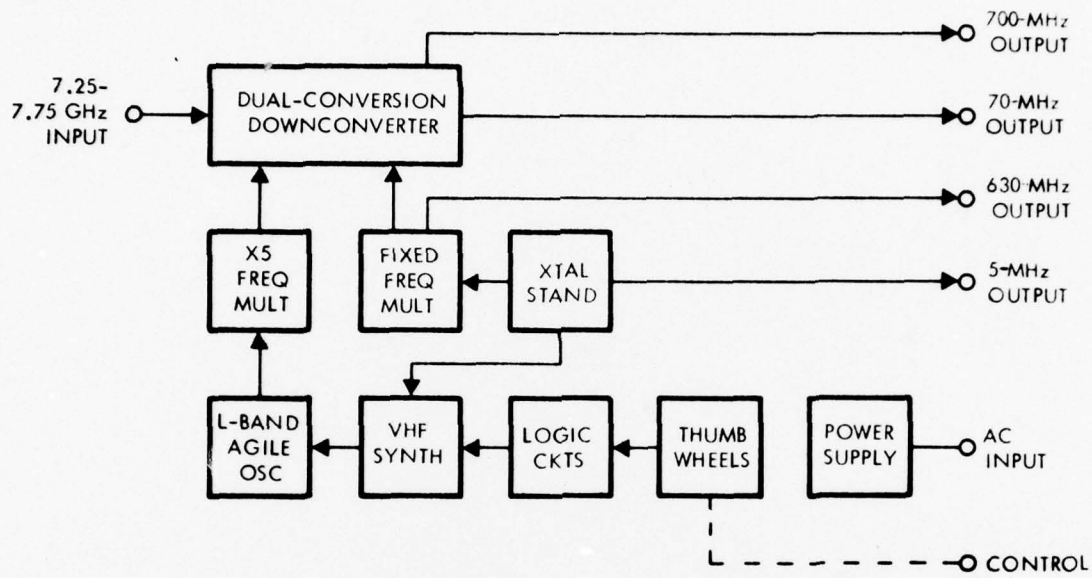

87283-9A

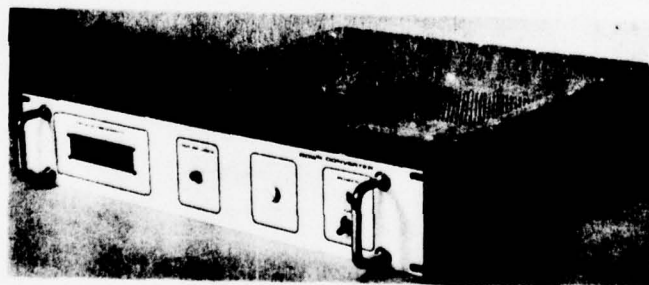

Figure 2.14-5. Downconverter

# DATA SHEET

## DUAL CONVERSION DOWNCONVERTER

### Description

This rack-mountable configuration incorporates a VHF synthesizer, LO multiplier chain, 5 MHz frequency standard, 5/630 MHz fixed frequency multiplier (FFM), and the X-band/700 MHz and 700/70 MHz modules to provide a completely self-contained drawer, ready for system integration. The desired X-band input frequency is set in on the thumb-wheel switches which read out directly in the 7.25 to 7.75 GHz range. The synthesizer-LO chain is frequency agile, requiring no manual tuning.

### Performance:

Input Frequency: 7.25 to 7.75 GHz, -41 dBm, maximum

Instantaneous BW: 40 MHz to the 70 MHz output; 125 MHz to the 700 MHz output

Noise Figure: 15 dB maximum

### Performance:

Channel Spacing: 500 KHz

Signal Outputs: 70 MHz and 700 MHz, -5 dBm maximum to system demodulators

Reference Outputs: 5 MHz and 630 MHz, to companion up-converter

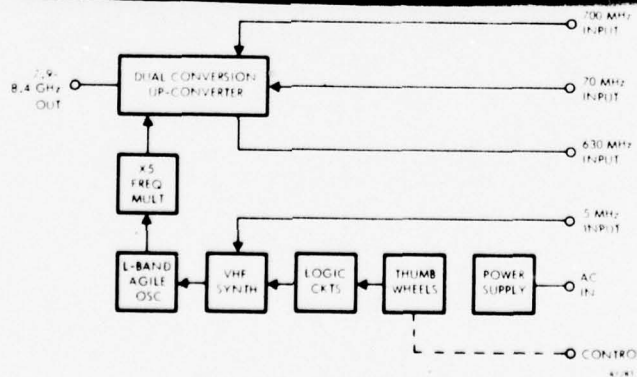

Figure 2.14-6. Upconverter

SECTION 3.0  
TEST RESULTS

## 3.0 TEST RESULTS

Test data on individual circuits and modules were presented in the Developmental Approach, the preceding section of this report. Those data, of course, do not describe the end-to-end performance of the converter drawers in their final configurations.

This section presents the results of top-level tests that were conducted after assembly of the drawers. These are tests that give a true indication of the performance to be expected in actual satellite ground terminal use. The tests on the upconverter drawer are given first, followed by the tests on the downconverter drawer. Then, data are presented on the two converter frequency synthesizers. Finally, simulated link tests with PSK modems are described.

### 3.1 Upconverter Tests

The upconverter drawer tests consisted of measurement of amplitude flatness and differential time delay, from the 70 MHz input to the X-band output.

#### 3.1.1 Amplitude Flatness

The amplitude flatness test consisted of applying a swept signal of greater than 40 MHz bandwidth at the 70 MHz input and measuring the X-band output level. To cover the full 500 MHz instantaneous RF bandwidth, 13 separate measurements were made, each at separate second local oscillator frequencies 40 MHz apart.

An HP8601A sweep generator was used to generate the input signal. The output was observed on an HP8555A/8552B/141T spectrum analyzer. Both the 630 MHz first local oscillator and the 5 MHz standard input to the synthesizer were supplied from the downconverter drawer in the normal operating configuration.

Figure 3.1-1 shows the 70 MHz swept input signal as observed on the spectrum analyzer. Its amplitude appears to have about a 0.5 dB peak-to-peak variation over the center  $\pm 20$  MHz, with the maximum occurring between 70 and 80 MHz.

Figures 3.1-2a through 3.1-2m show the X-band output as observed on the spectrum analyzer. The horizontal and vertical scales are 10 MHz/cm and 2 dB/cm, respectively. All

Figure 3.1-1. Reference Amplitude Flatness

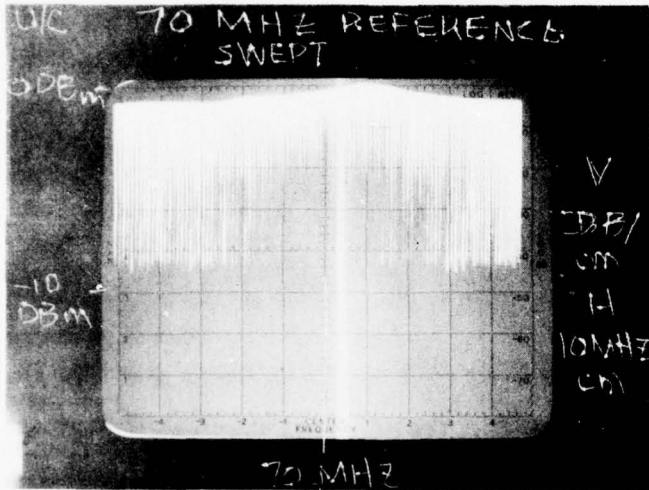

Figure 3.1-1

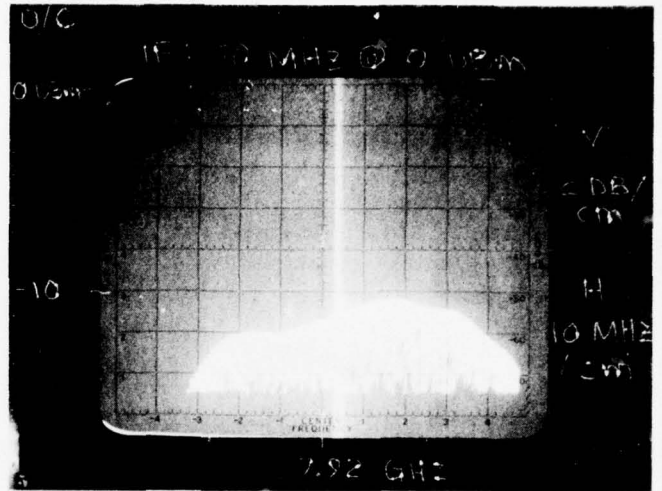

Figure 3.1-2a

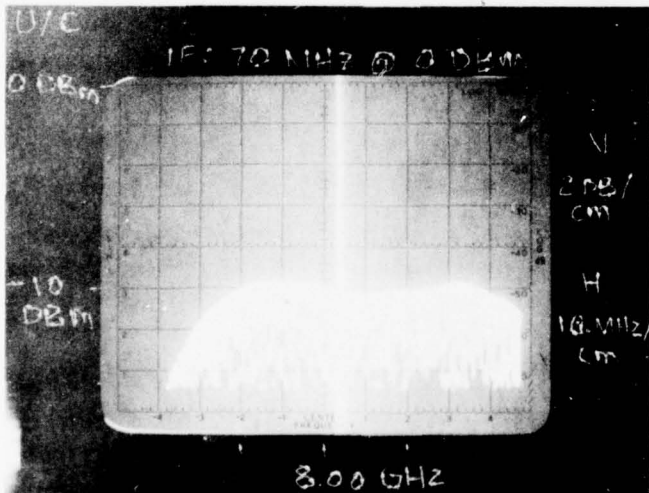

Figure 3.1-2b

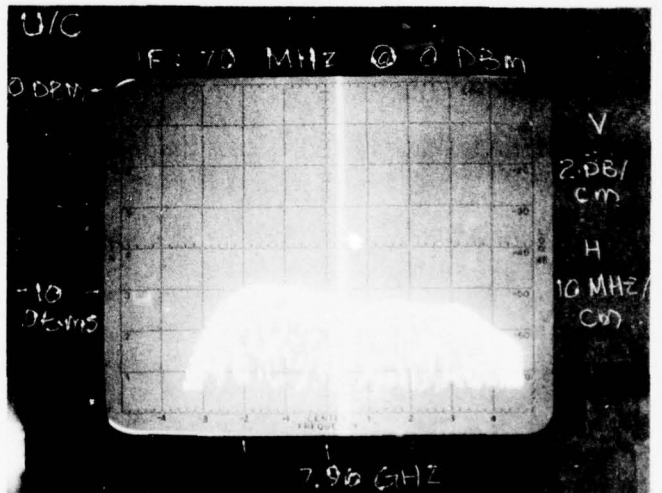

Figure 3.1-2c

Figure 3.1-2. Upconverter Amplitude Flatness

87924-47

Figure 3.1-2. Upconverter Amplitude Flatness (Continued)

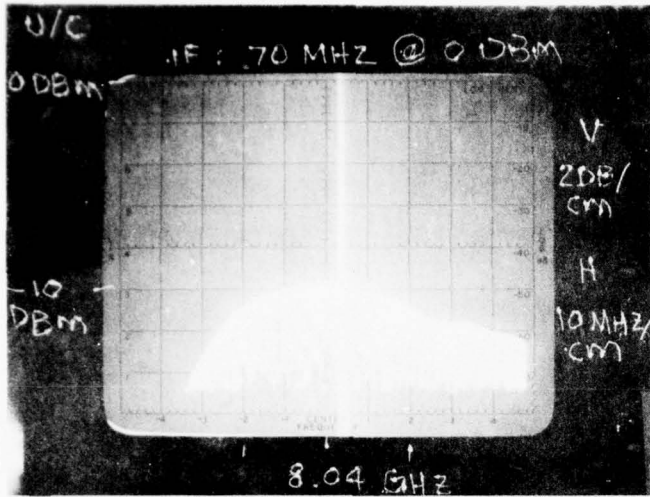

Figure 3.1-2d

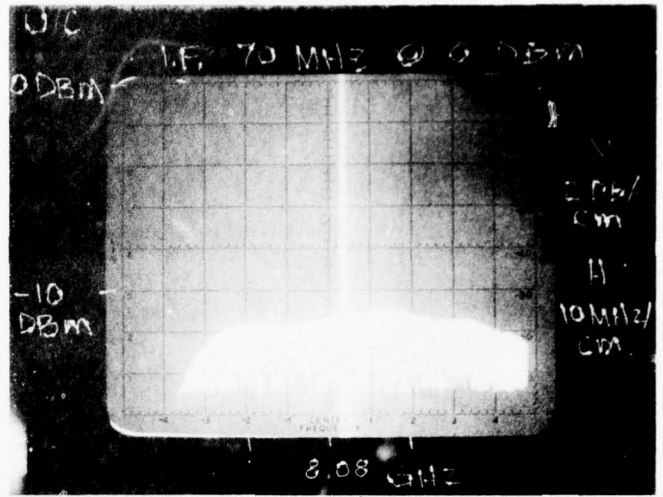

Figure 3.1-2e

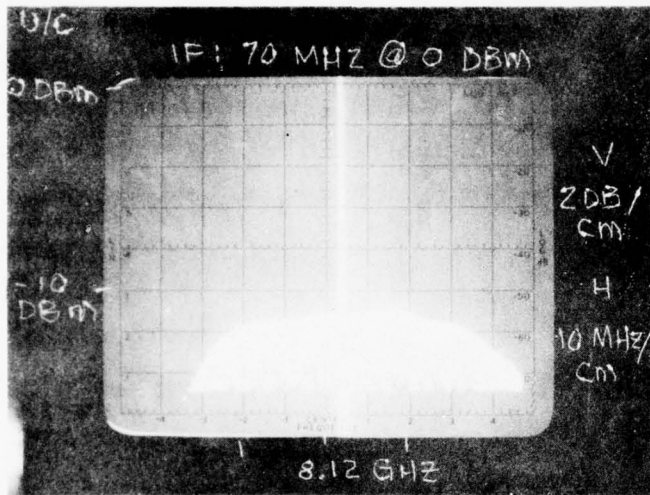

Figure 3.1-2f

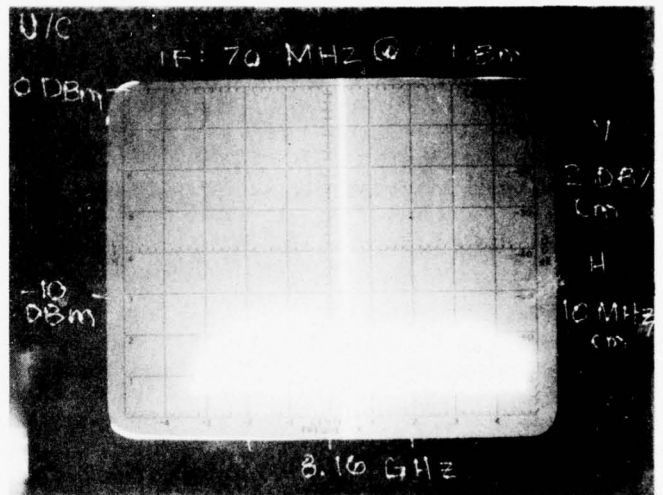

Figure 3.1-2g

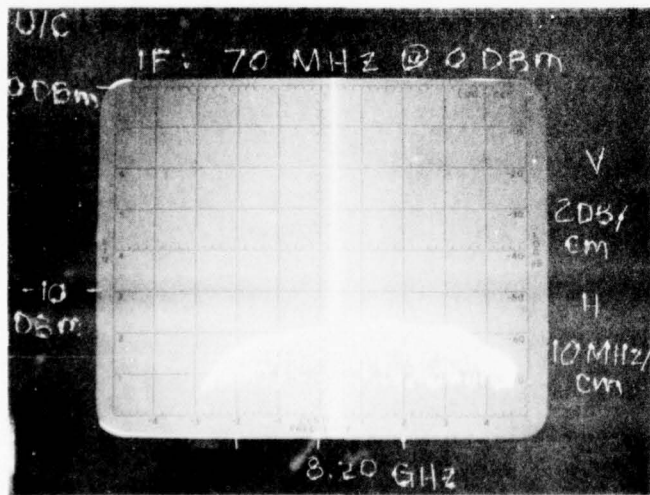

Figure 3.1-2h

87924-48

Figure 3.1-2. Upconverter Amplitude Flatness (Continued)

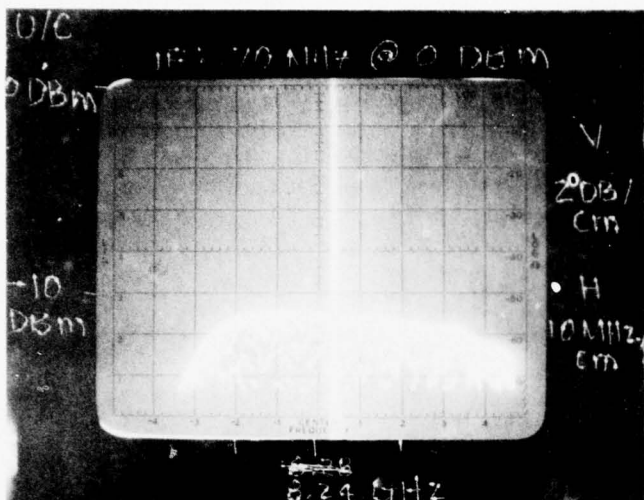

Figure 3.1-2i

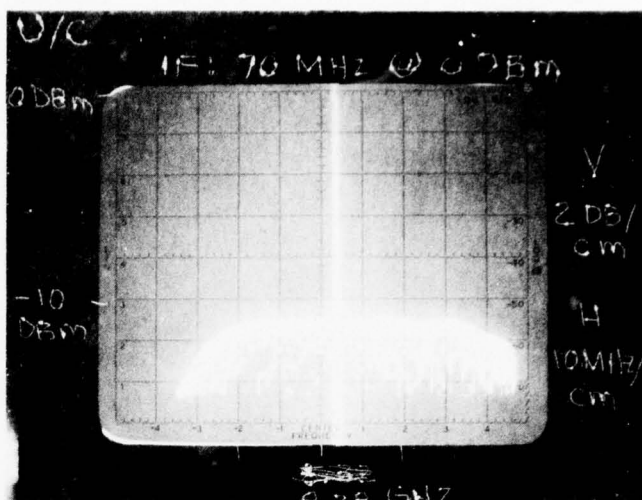

Figure 3.1-2j

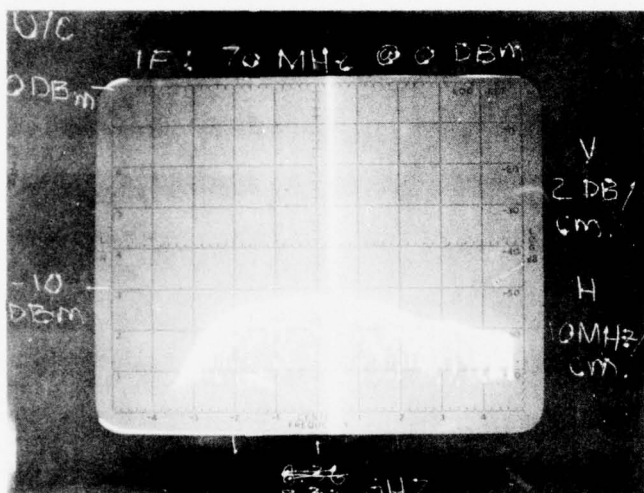

Figure 3.1-2k

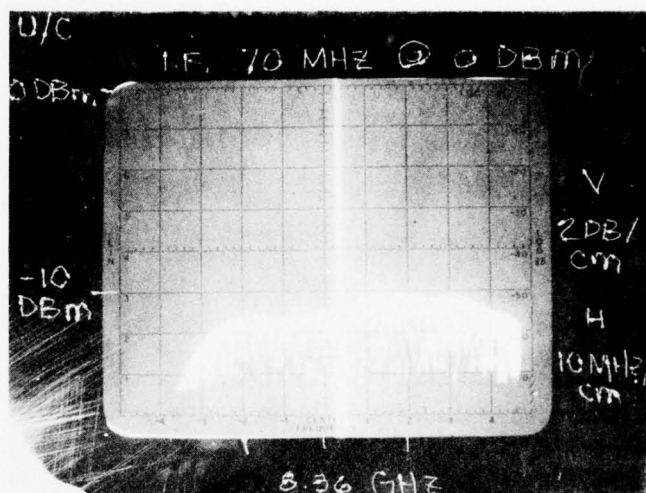

Figure 3.1-2l

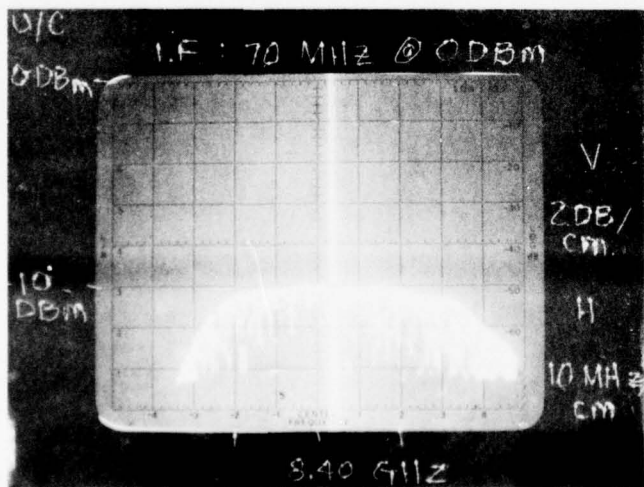

Figure 3.1-2m

87924-49

responses are of similar shape, with rolloff beyond the  $\pm 20$  MHz center-portion due to the filtering in the 700 MHz IF and the response of the 70 MHz IF. The worst-case amplitude variation over the center  $\pm 20$  MHz is about 1.2 dB peak-to-peak.

### 3.1.2 Differential Time Delay

The differential time delay test consisted of applying a modulated swept signal of 40 MHz bandwidth at the 70 MHz input and measuring the modulation delay at the X-band output. To cover the full 500 MHz instantaneous RF bandwidth, 13 separate measurements were made, each at separate second local oscillator frequencies 40 MHz apart.

A HP8061A sweep generator was used to generate the input RF signal. Modulation, demodulation and measurement were performed with a Rantec ET-300 time delay test set and accessories, and the delay was displayed on a Tektronix 547 oscilloscope. Both the 630 MHz first local oscillator and the 5 MHz standard input to the synthesizer were supplied from the downconverter drawer in the standard configuration.

Figure 3.1-3 shows the reference delay variation, about 1.4 ns peak-to-peak over  $\pm 20$  MHz.

Figures 3.1-4a through 3.1-4m show the overall converter differential delay. The horizontal and vertical scales are 5 MHz/cm and 1 ns/cm, respectively. All 13 responses are quite similar, with the greatest delay being at the lowest frequency and being off-scale at that point on some of the photographs. Allowing for the reference delay variation, the actual converter differential time delay is about 6 ns peak-to-peak.

The delay variation in the converter originates mainly in the 700 MHz IF. The ripple is primarily due to the 700 MHz bandpass filter, and the steep slope at the low band edge is caused by the elliptic-function highpass filter used to attenuate the 630 MHz leakage from the first mixer.

Figure 3.1-3. Reference Delay Variation

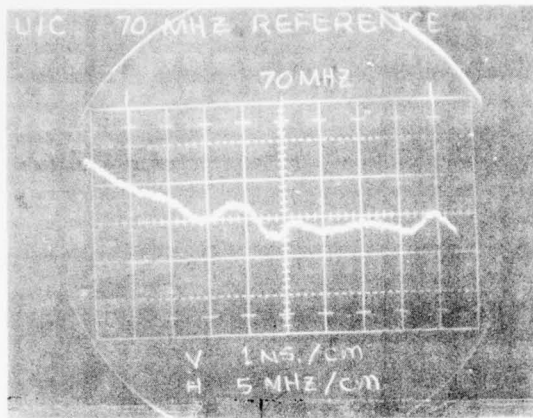

Figure 3.1-3

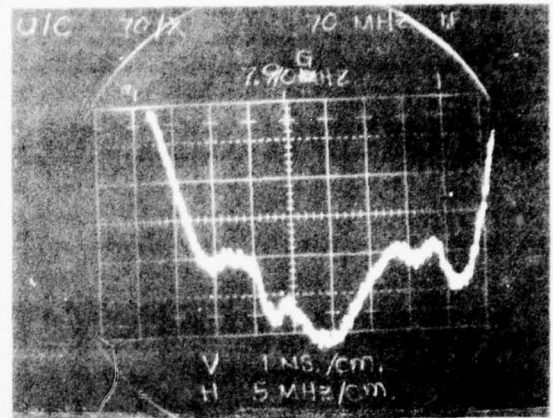

Figure 3.1-4a

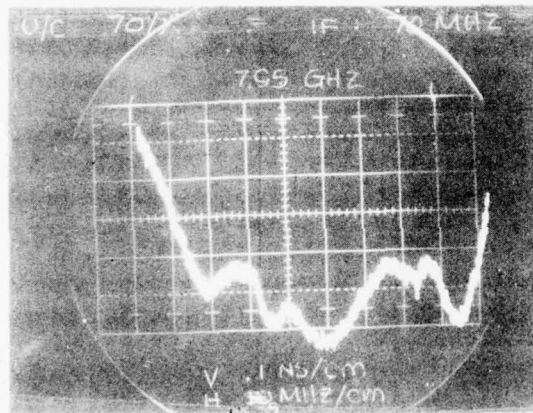

Figure 3.1-4b

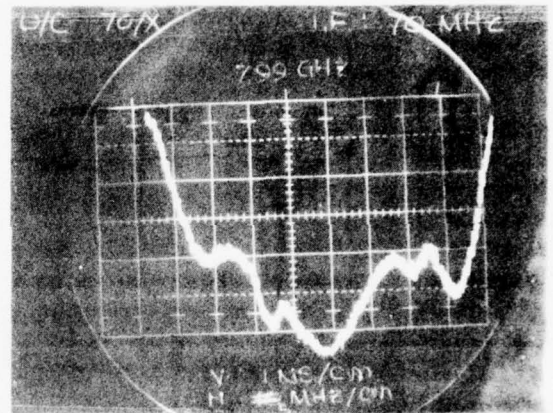

Figure 3.1-4c

87924-50

Figure 3.1-4. Upconverter Differential Time Delay

Figure 3.1-4. Upconverter Differential Time Delay (Continued)

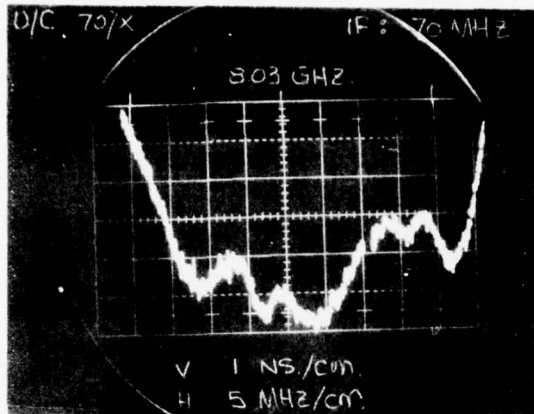

Figure 3.1-4d

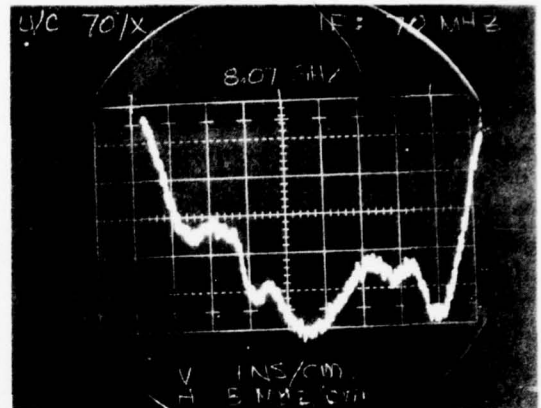

Figure 3.1-4e

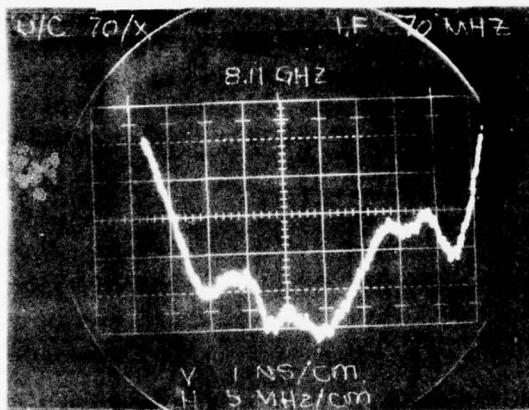

Figure 3.1-4f

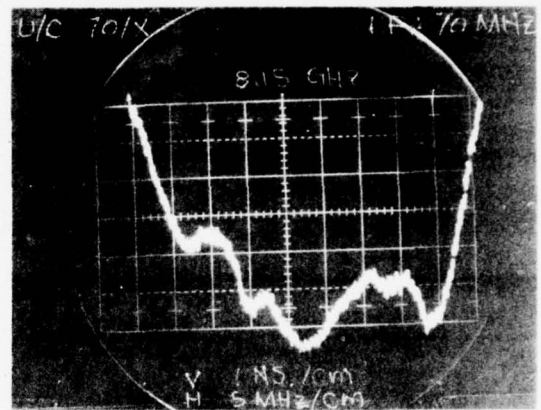

Figure 3.1-4g

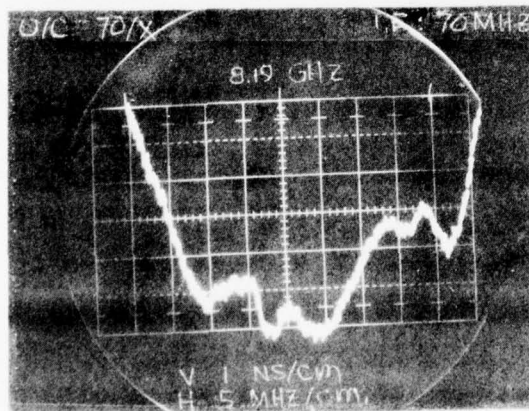

Figure 3.1-4h

87924-51

Figure 3.1-4. Upconverter Differential Time Delay (Continued)

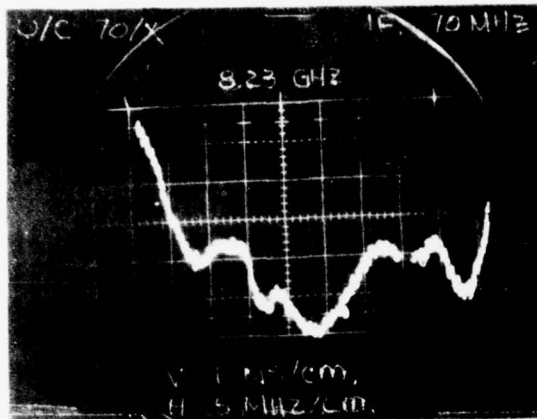

Figure 3.1-4i

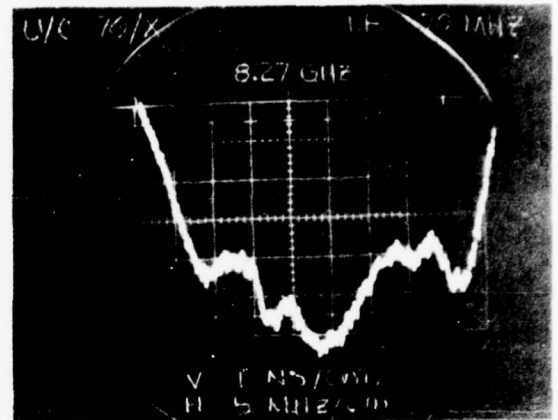

Figure 3.1-4j

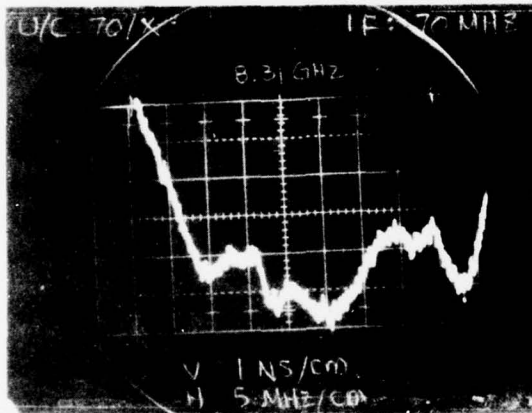

Figure 3.1-4k

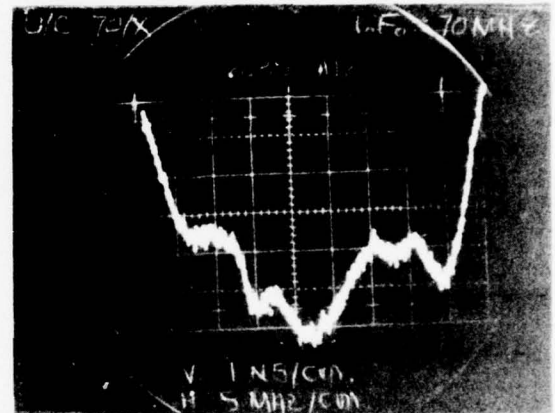

Figure 3.1-4l

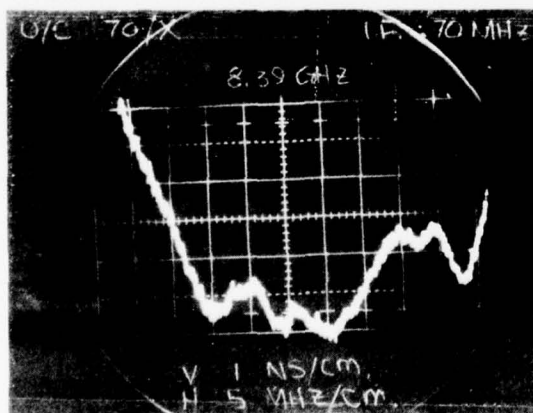

Figure 3.1-4m

87924-52

## 3.2 Downconverter Tests

The downconverter drawer tests consisted of measurement of amplitude flatness, differential time delay and noise figure, from the X-band input to the 70 MHz output.

### 3.2.1 Amplitude Flatness

The amplitude flatness test consisted of applying a swept signal of greater than 40 MHz bandwidth at the X-band input and measuring the 70 MHz output level. To cover the full 500 MHz RF bandwidth, 13 separate measurements were made, each at separate local oscillator frequencies 40 MHz apart.

An HP8690B/8693B sweep generator was used to generate the input signal. The output was observed on an HP8555A/8552B/141T spectrum analyzer.

Figures 3.2-1a through 3.2-1m show the 70 MHz output as observed on the spectrum analyzer. The horizontal scale is 10 MHz/cm, and the vertical scale is 2 dB/cm. The amplitude response is essentially the same in all cases, with a peak in the vicinity of 70 MHz and less than 1 dB peak-to-peak variation over the center  $\pm 20$  MHz.

### 3.2.2 Differential Time Delay

The differential time delay test consisted of applying a modulated swept signal of 40 MHz bandwidth at the X-band input and measuring the modulation delay at the 70 MHz output. To cover the full 500 MHz RF bandwidth, 13 separate measurements were made, each at separate second local oscillator frequencies 40 MHz apart.

A HP8690B/8693B sweep generator was used to generate the input RF signal. Modulation, demodulation and measurement were performed with a Rantec ET-300 time delay test set and accessories, and the delay was displayed on a Tektronix 547 oscilloscope.

Figure 3.2-2 shows the reference delay variation, and Figures 3.2-3a through 3.2-3m show the overall converter differential delay. The horizontal and vertical scales are 4 MHz/cm and 1 ns/cm, respectively. All 13 responses are essentially the same, with about 4 ns peak-to-peak differential delay over the 40 MHz bandwidth.

Figure 3.2-1. Downconverter Amplitude Flatness

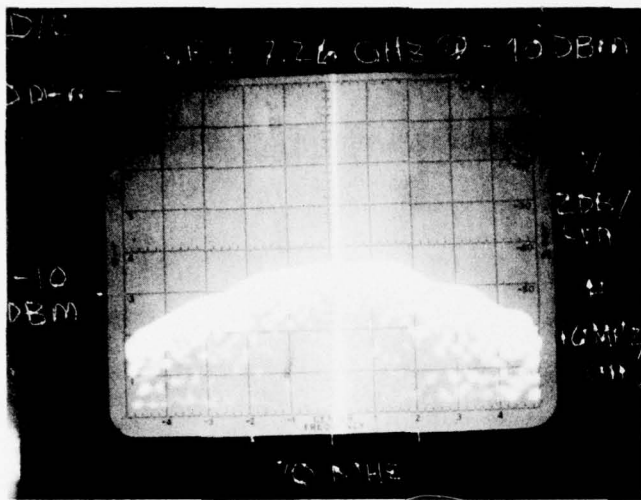

Figure 3.2-1a

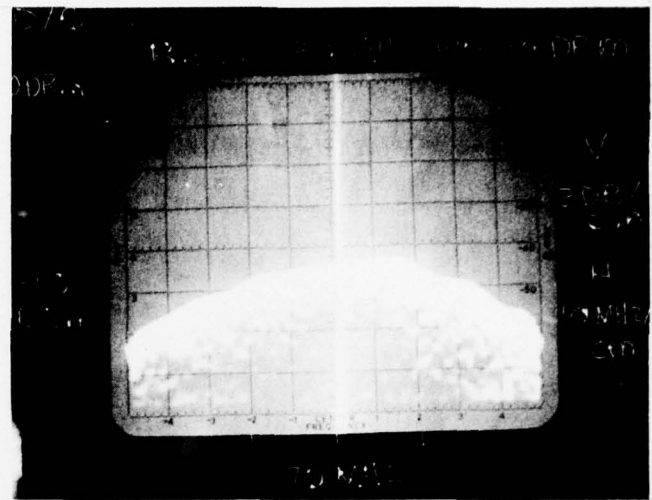

Figure 3.2-1b

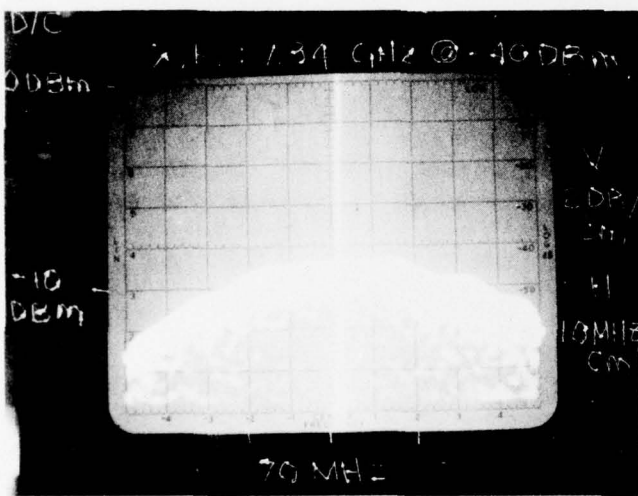

Figure 3.2-1c

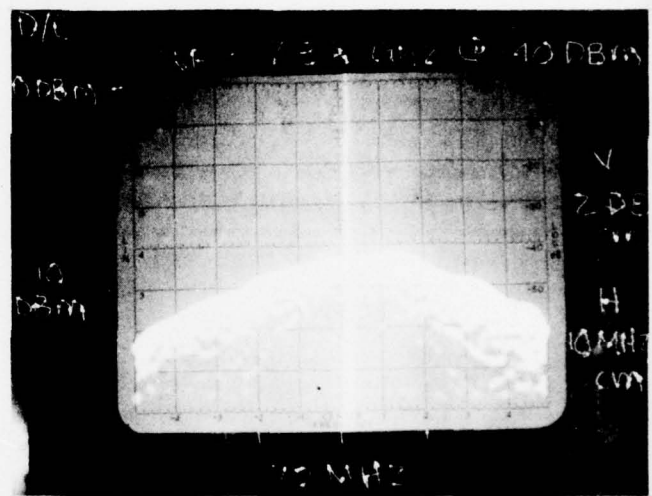

Figure 3.2-1d

Figure 3.2-1. Downconverter Amplitude Flatness (Continued)

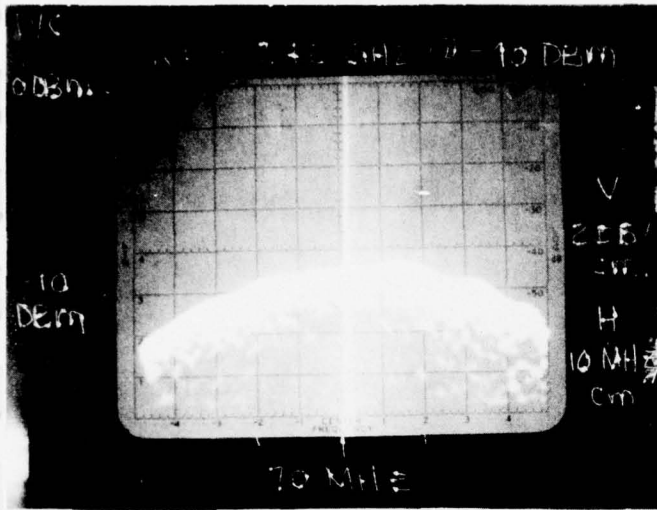

Figure 3.2-1e

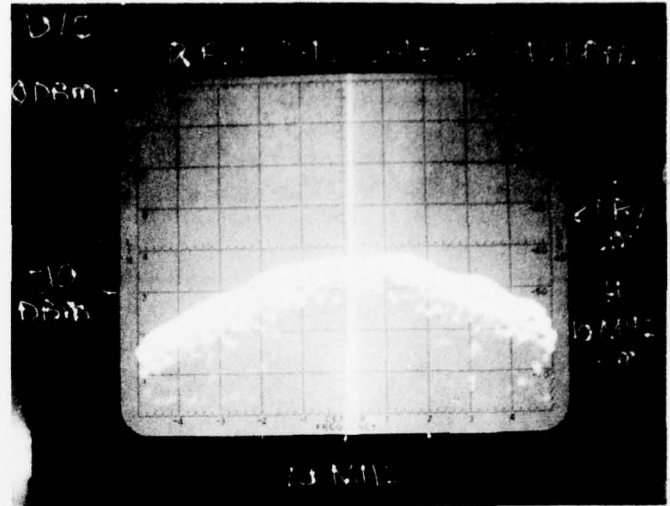

Figure 3.2-1f

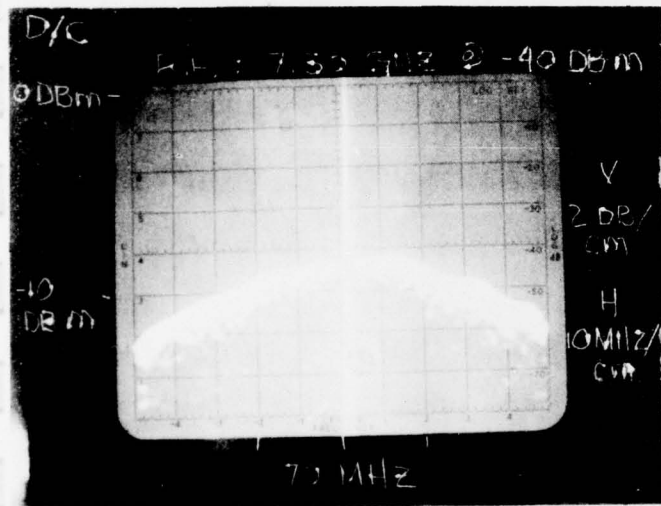

Figure 3.2-1g

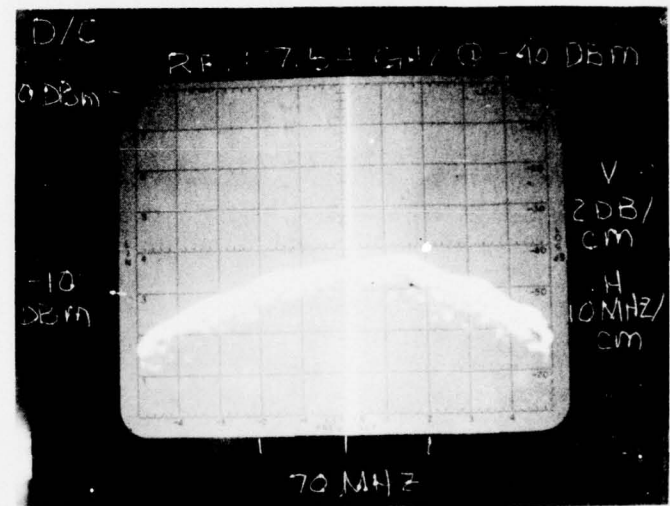

Figure 3.2-1h

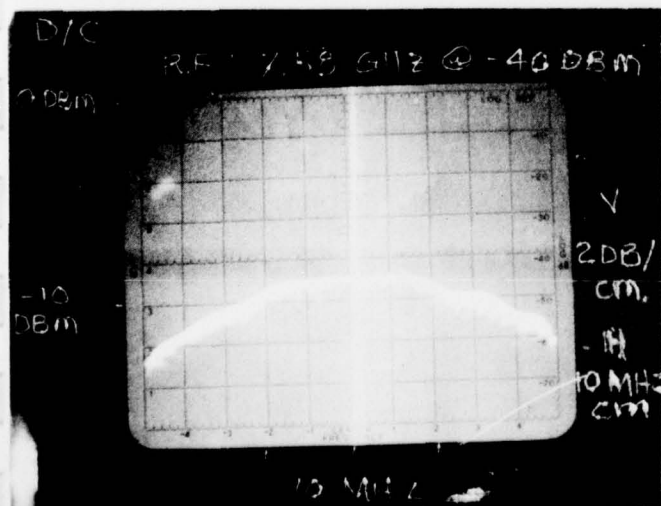

Figure 3.2-1i

87924-54

Figure 3.2-1. Downconverter Amplitude Flatness (Continued)

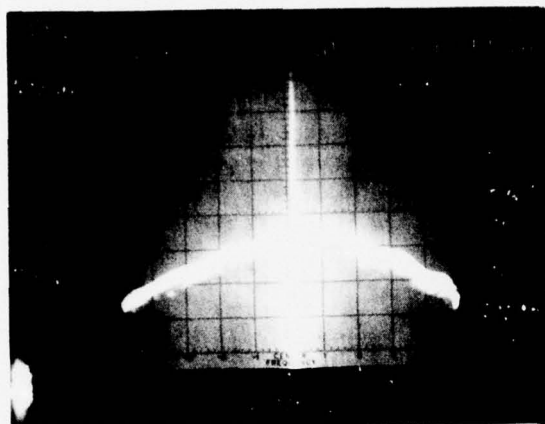

Figure 3.2-1j

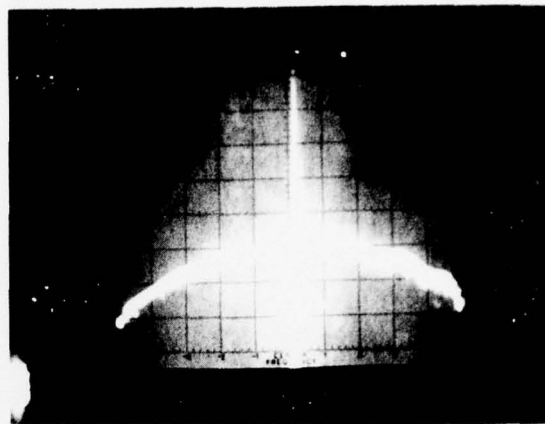

Figure 3.2-1k

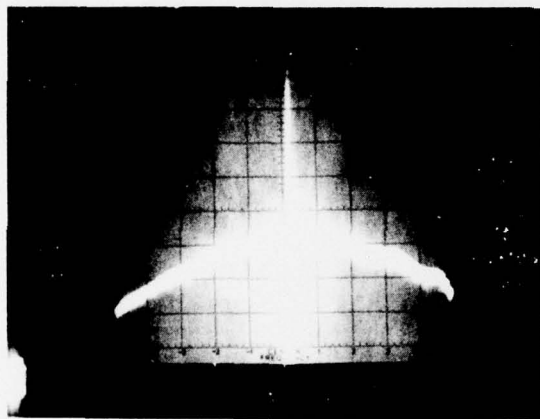

Figure 3.2-1l

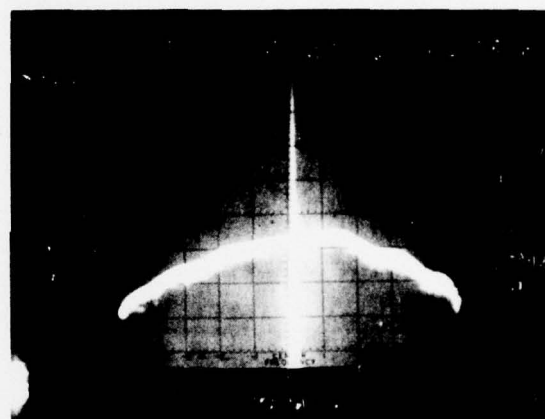

Figure 3.2-1m

*L. Maria p.*  
TEST

87924-55

31

*L. Maria p.*

Figure 3.2-2. Reference Delay Variation

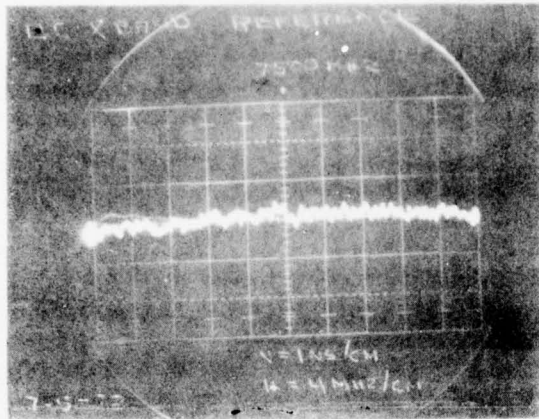

Figure 3.2-2

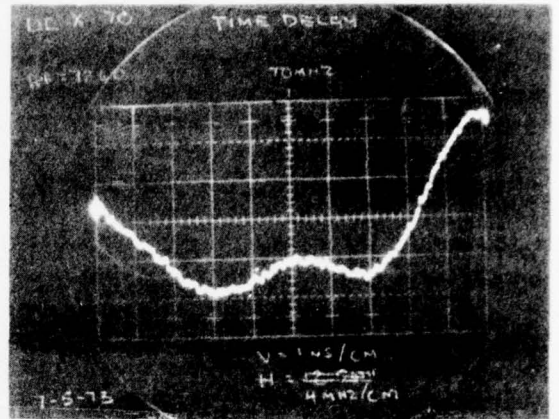

Figure 3.2-3a

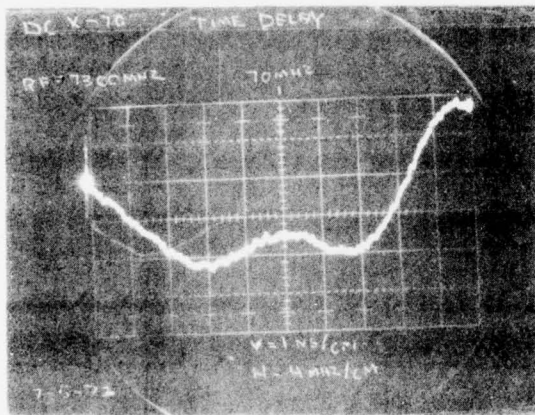

Figure 3.2-3b

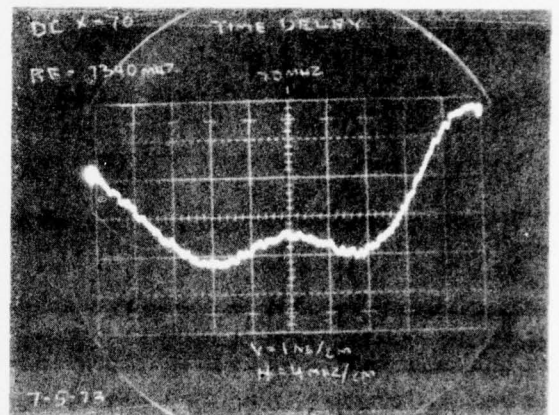

Figure 3.2-3c

87924-56

Figure 3.2-3. Downconverter Differential Time Delay

Figure 3.2-3. Downconverter Differential Time Delay (Continued)

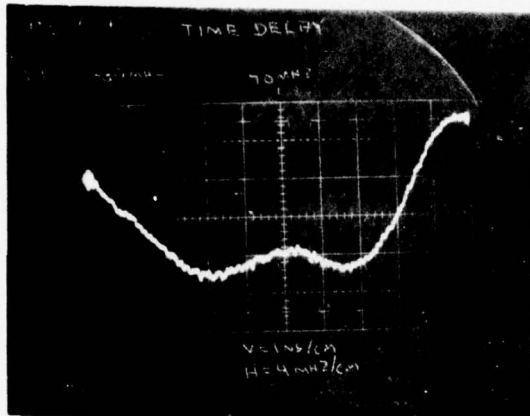

Figure 3.2-3d

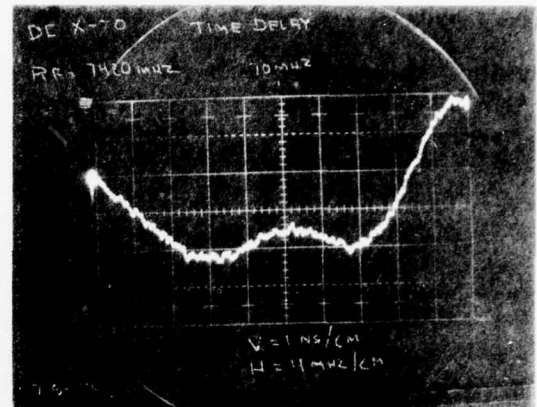

Figure 3.2-3e

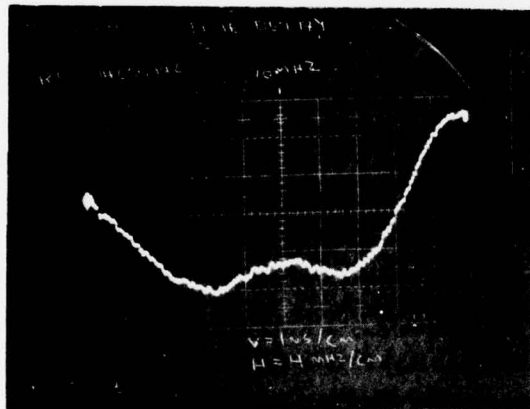

Figure 3.2-3f

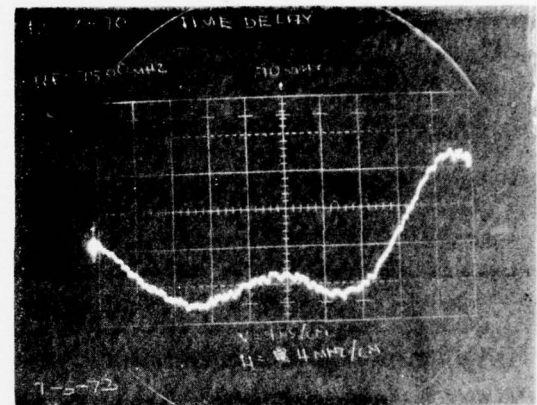

Figure 3.2-3g

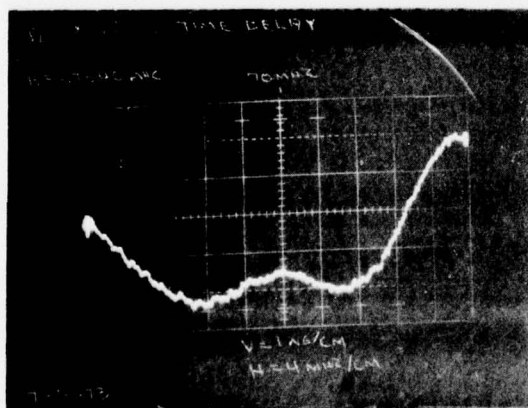

Figure 3.2-3h

87924-57

Figure 3.2-3. Downconverter Differential Time Delay (Continued)

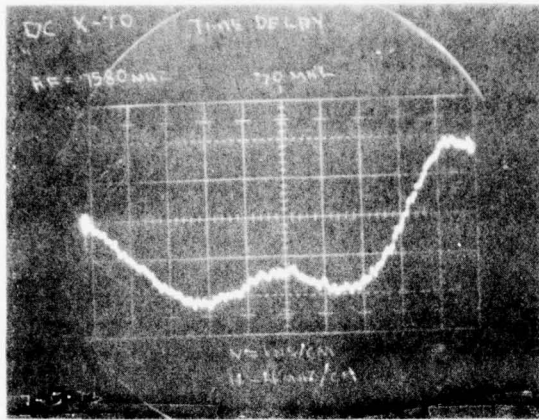

Figure 3.2-3j

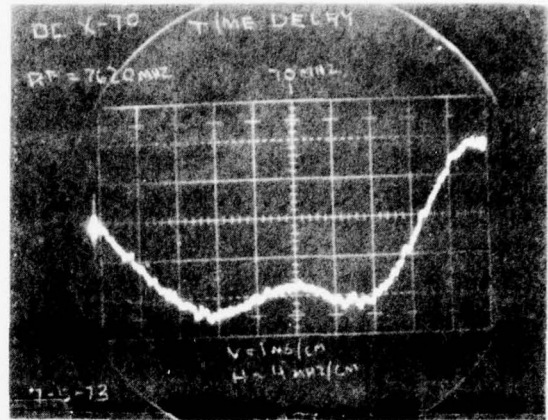

Figure 3.2-3i

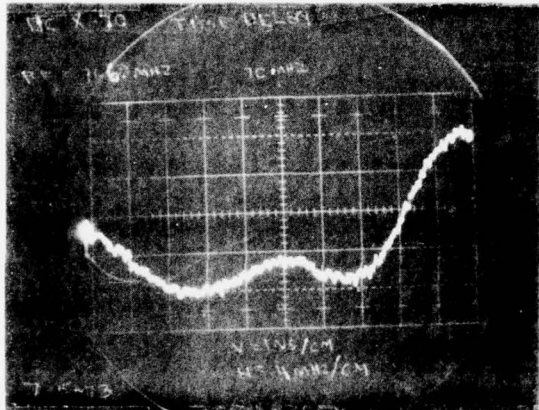

Figure 3.2-3k

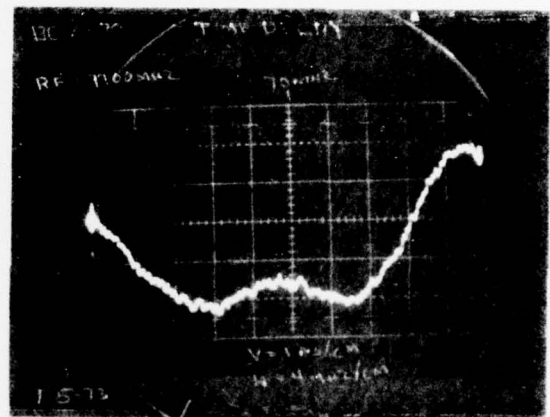

Figure 3.2-3l

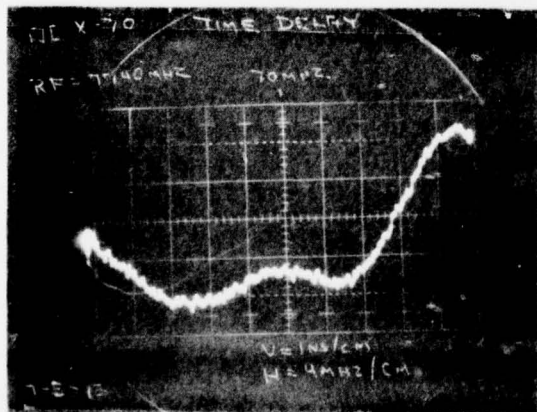

Figure 3.2-3m

87924-58

The response is determined mainly by the bandpass filtering in the 700 MHz IF and the lowpass filtering in the 70 MHz IF. The 70 MHz lowpass filter contributes a linear term of approximately .05 ns/MHz, and the 700 MHz bandpass filter produces the symmetrical (i.e., parabolic and higher even-order) characteristic.

### 3.2.3 Noise Figure

The noise figure of the downconverter was measured with the test setup shown in Figure 3.2-4. Measurements were made at five first local oscillator frequencies, corresponding to RF input frequencies of 7250, 7375, 7500, 7625 and 7750 MHz. The results are tabulated below.

LO Frequency (MHz)	Receive Frequency (MHz)	Noise Figure	
		Measured (dB)	Corrected* (dB)
6550	7250	16.5	15.5
6675	7375	16.1	15.1
6800	7500	16.0	15.0
6925	7625	16.7	15.7
7050	7750	16.75	15.75

\* Corrected for 1.0 dB insertion loss of filter placed between noise source and downconverter input

### 3.3 Synthesizer Spectral Purity

The spectral purity of a frequency source is defined by the broadband phase noise and discrete spurious content of its output. For the downconverter and upconverter frequency synthesizers, the phase noise was measured by measuring the noise spectral density on a point-by-point basis.

A FEL 800B phase noise analyzer followed by a GR 1900-A wave analyzer was used for the noise measurements. The output of the synthesizer was translated down to the 27.365 MHz input frequency of the phase noise analyzer using a Fluke 6160A frequency

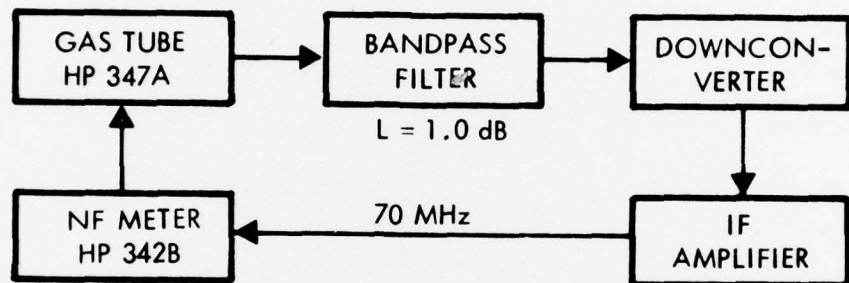

87924-59

Figure 3.2-4. Downconverter Noise Figure Test Setup

synthesizer for the local oscillator. The downconverter synthesizer was set at 130 MHz for these measurements, and the upconverter synthesizer was set at 151 MHz.

Figure 3.3 shows plots of the single-sided (i.e., double-sideband) phase noise power spectral density for the two synthesizers.

The downconverter synthesizer has much higher low-frequency noise than the upconverter synthesizer for undetermined reasons. Sharp peaking anomalies in the two plots are also of undetermined origin. It is suspected that these anomalies resulted from external noise pickup caused by an arc welder operating in the proximity of the laboratory.

The downconverter synthesizer displays a basically flat (except for the two unexplained peaks) noise density of about  $-92$  dB/Hz from 260 Hz to 4 kHz, with a slow rolloff beyond 4 kHz due to the response of the coarse synthesizer loop and the multiplied coarse loop reference noise. The upconverter synthesizer noise spectrum is similarly shaped but 2-5 dB higher due to the higher noise multiplication factor and about 2 dB of peaking in the coarse loop response.

Discrete spurious outputs are not shown in Figure 3.3. Sidebands appear at  $\pm 40$  kHz from the carrier, due to the fine synthesizer loop, at levels of  $-70$  to  $-62$  dB ( $-60$  dB specification limit). Also, sidebands appear at multiples of the 60 Hz line frequency.

The contractual objectives for spectral purity were met, but it was discovered that excessive performance degradation was encountered when the equipment was used for PSK, as opposed to FM/FDMA - communication. After delivery of the equipment to USASATCOMA, it was loaned back to Radiation so that the causes could be determined and corrective action could be taken.

It was found that some circuits in the converter drawers were especially susceptible to hum, whatever its origin. The most sensitive circuits were in the synthesizers. Circuit modifications were made, in the form of adding improved voltage and/or current regulation locally at critical points in the synthesizers. It was also necessary to magnetically shield some components from the high ambient fields set up by transformers in the power supplies.

At present, work is still in progress to reduce hum sidebands. A supplement will be issued to this report to cover this work and its results in terms of the performance of the terminal.

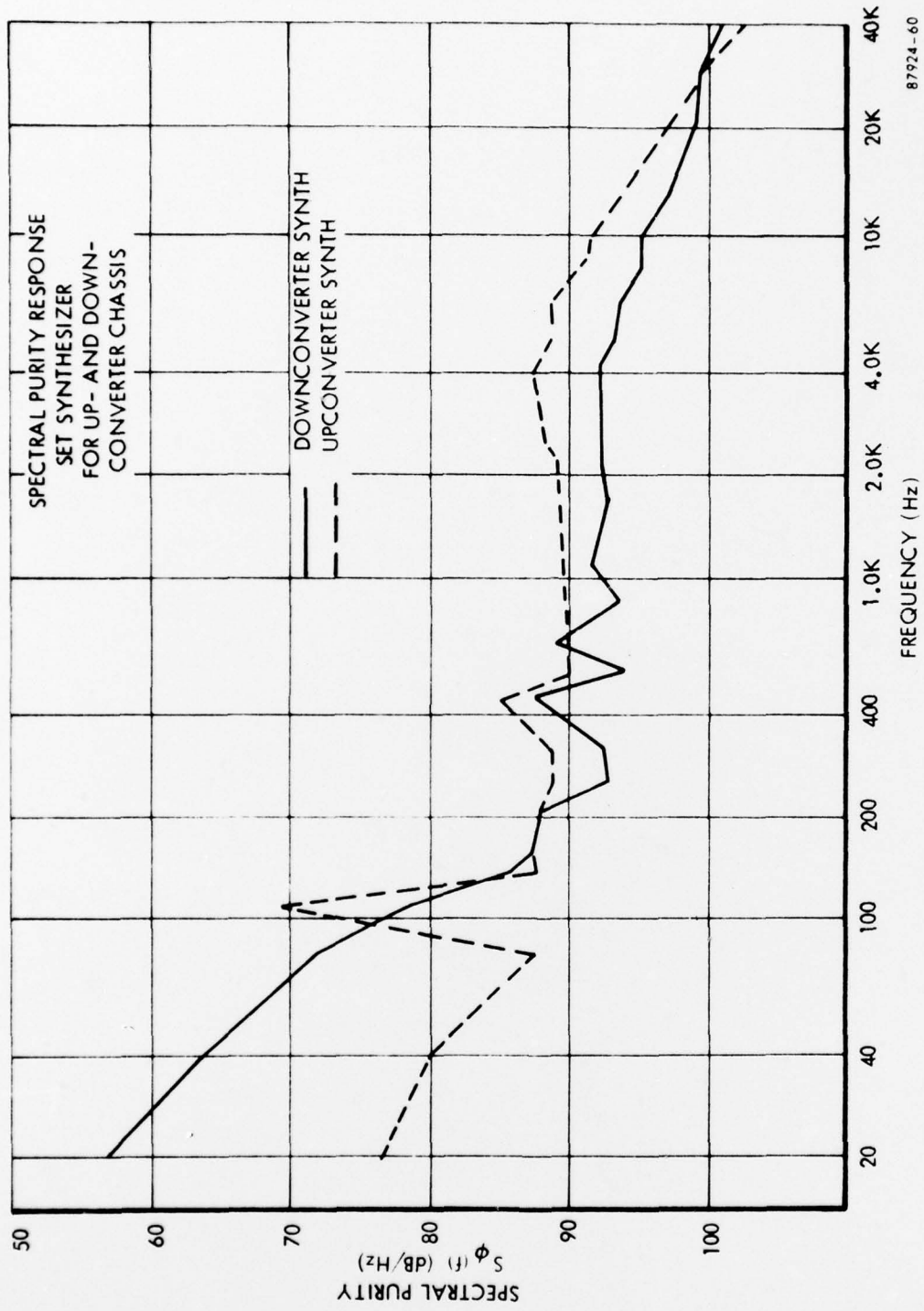

Figure 3.3. VHF Synthesizer Spectral Purity

### 3.4 Link Tests

Simulated link tests have been and are being conducted on the converters, using PSK modems and measuring BER (bit error rate) versus  $E_b/N_o$  (ratio of signal power to noise power in a bit rate bandwidth). These tests have not been completed as of the deadline for submission of this report, as modifications are still being made to the equipment to suppress the effects of the 60 Hz magnetic field.

Rather than include incomplete link test data in this report, an addendum to the report will be prepared and distributed at the completion of testing. This addendum will briefly describe the equipment modifications as well as providing the link test data and relating the data to actual DSCS-II terminal applications.

SECTION 4.0

SUMMARY

#### 4.0 SUMMARY

This exploratory development program was established to determine the applicability of solid-state technology to satellite communications systems. In particular, hybrid microwave integrated circuit (HMIC) techniques were to be applied to accomplish a terminal design that would feature light weight, small size, low prime power consumption and low cost. HMIC fabrication, using microstrip circuits on high dielectric constant substrates, provides functions which are inherently small in size and light in weight compared to conventional construction techniques. The planar geometry permits batch processing by photolithographic techniques and allows convenient access for attachment of discrete components. In addition, HMIC fabrication reduces the number of interconnections and stabilizes the parasitic circuit elements, yielding designs which are predictable and hence reproducible. It is anticipated that these fundamental characteristics of HMIC circuits will lower the production labor content and, therefore, reduce the production cost of the finished assembly.

HMIC designs (more specifically, traditional microstrip designs) are not suitable where high unloaded  $Q$  is required, or where operating current densities or voltage gradients will cause overheating or dielectric breakdown. Examples encountered in the development work on this program include the 500 MHz bandwidth X-band filters preceding the LNA and following the solid-state power amplifier. In both cases, the number of filter poles required to attain the selectivity needed led to excessive loss using microstrip designs. In other areas where low loss was not as critical, such as the X-band upconverter output and in the microwave LO circuits, microstrip filters were used with very satisfactory results.

The entire development activity was characterized by a continuing effort to provide the best balance or "mix" of function, performance and design approach. Computer-aided analysis, synthesis and optimization routines were used extensively in the design of all of the microwave microstrip mixers and filters, and for the 700 MHz IF preamplifier in the X-band/700 MHz downconverter module. Diverse interfaces, fabrication techniques and devices, (e.g., microstrip, stripline, lumped elements, distributed elements) were accommodated in order to realize an overall successful design which has real potential for low cost in production.

The single-aperture configuration which evolved allowed the program hardware to be demonstrated operating through the earth coverage mode of the DSCS-II satellite and through

an IDCSP satellite. For this configuration, all of the up- and downconverter modules, including the synthesizers and all power supplies, were packaged in 3-1/2 inch high rack-mountable drawers. A convenient feature incorporated in these drawers is the direct readout of the desired X-band operating frequency on the thumbwheel switches. This is accomplished by the use of a unique programmable arithmetic unit which provides the interface between the thumbwheel switches and the VHF synthesizer.

It is estimated that with further product engineering, the technology utilized in the fabrication of these converters will permit a 1:1 ratio of material to labor in production. With the production material bill estimated to be \$5,000 or less, a \$10,000 cost for either converter is judged a realizable goal.

This report has described the development activity and the resulting developmental hardware, and it includes extensive test data. However, it is incomplete inasmuch as it does not present a description of, and data from, simulated link tests which were not a part of this contract. At the time of the preparation of the report, link testing is still in progress. An addendum to this report, describing link tests and supplying test data, will be distributed in the near future.