

AD-A038 621

NAVAL POSTGRADUATE SCHOOL MONTEREY CALIF  
DESIGN CONSIDERATIONS FOR LANCHESTER-TYPE MODELS OF WARFARE (LA--ETC(U)  
SEP 76 H MAUERER

F/G 15/7

UNCLASSIFIED

NL

1 of 2  
ADA038621

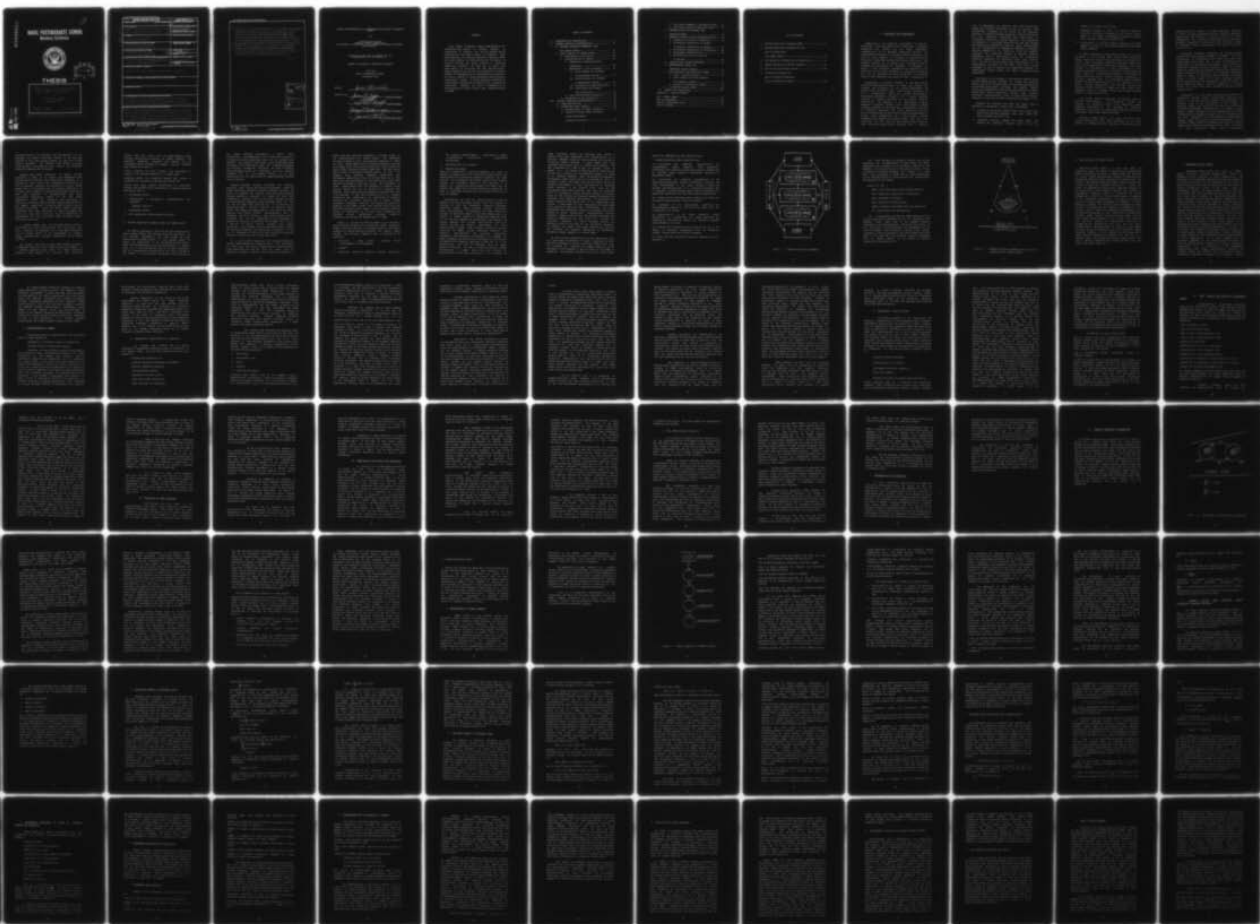

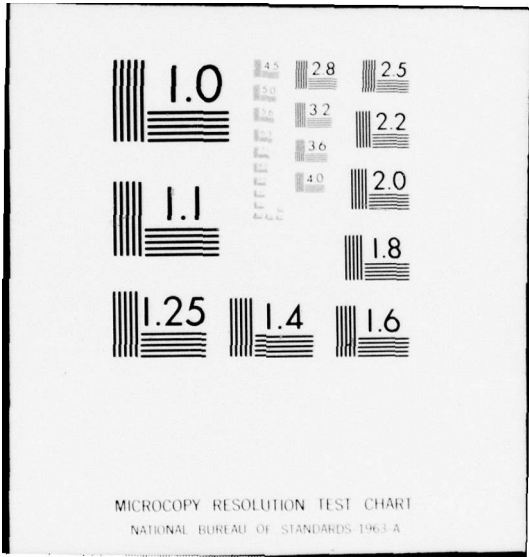

MICROCOPY RESOLUTION TEST CHART  
NATIONAL BUREAU OF STANDARDS-1963-A

AD A 038621

NAVAL POSTGRADUATE SCHOOL  
Monterey, California



DDC  
RECEIVED  
APR 26 1977  
RECEIVED  
B

THESIS

DESIGN CONSIDERATIONS FOR LANCHESTER-  
TYPE MODELS OF WARFARE (LATMW)

by

Herbert-Hans Mauerer

September 1976

Thesis Advisor:

J. G. Taylor.

Approved for public release; distribution unlimited.

AD No. \_\_\_\_\_  
DDC FILE COPY

REPORT DOCUMENTATION PAGE		READ INSTRUCTIONS BEFORE COMPLETING FORM
1. REPORT NUMBER	2. GOVT ACCESSION NO.	3. RECIPIENT'S CATALOG NUMBER
4. TITLE (and Subtitle) Design Considerations for Lanchester-type Models of Warfare (LATMW).		5. TYPE OF REPORT & PERIOD COVERED Master's Thesis, September 1976
7. AUTHOR(s) Herbert-Hans Mauerer		6. PERFORMING ORG. REPORT NUMBER
9. PERFORMING ORGANIZATION NAME AND ADDRESS Naval Postgraduate School Monterey, California 95940		8. CONTRACT OR GRANT NUMBER(s)
11. CONTROLLING OFFICE NAME AND ADDRESS Naval Postgraduate School Monterey, California 95940		10. PROGRAM ELEMENT, PROJECT, TASK AREA & WORK UNIT NUMBERS
14. MONITORING AGENCY NAME & ADDRESS (if different from Controlling Office) Naval Postgraduate School Monterey, California 95940		12. REPORT DATE September 1976
		13. NUMBER OF PAGES 136
		15. SECURITY CLASS. (of this report) Unclassified
		18a. DECLASSIFICATION/DOWNGRADING SCHEDULE
16. DISTRIBUTION STATEMENT (of this Report)  Approved for public release; distribution unlimited.		
17. DISTRIBUTION STATEMENT (of the abstract entered in Block 20, if different from Report)		
18. SUPPLEMENTARY NOTES		
19. KEY WORDS (Continue on reverse side if necessary and identify by block number)  Land-Combat Models, Lanchester-type Models of Warfare, Evaluation Framework, Design Specifications, Model-Input Parameter Estimation, System Reliability and Availability.		
20. ABSTRACT (Continue on reverse side if necessary and identify by block number)  This thesis discusses design considerations for Lanchester-Type Models of Warfare (LATMW). It establishes a framework for setting minimum design standards for such combat models. We formalize these considerations in a Minimum Evaluation Framework (MEF) for combat models. The state-of-the-art for		

→ models is briefly reviewed and major pitfalls in modelling combat are sketched. We show how to avoid such shortcomings by following our MEF specifications. Modern combined arms forces are abstracted as coherent systems of complementary and supplementary components. We derive a method to refine Lanchester Attrition-Rate Coefficients (LARC) as system capability measures by additionally considering reliability and availability weightings. Examples are given to demonstrate the implementation of these refined LARC quantifications in LATNW!

is derived

ACCESSION for		
NTIS	White Section	<input checked="" type="checkbox"/>
DGC	Buff Section	<input type="checkbox"/>
UNANNOUNCED		<input type="checkbox"/>
JUSTIFICATION		
BY		
DISTRIBUTION/AVAILABILITY CODES		
Dist.	Avail.	and/or SPECIAL
A		

DESIGN CONSIDERATIONS FOR LANCHESTER-TYPE MODELS OF WARFARE  
(LATMW)

by

Herbert-Hans Mauerer  
Captain Federal German Army  
Betriebswirt (graduiert), 1971, Technical Military Academy,  
West-Germany

Submitted in partial fulfillment of the  
requirements for the degree of

MASTER OF SCIENCE IN OPERATIONS RESEARCH

from the  
NAVAL POSTGRADUATE SCHOOL  
September 1976

Author:

*Herbert H. Mauerer*

Approved by:

*James G. Taylor*

THESIS ADVISOR

*J. P. Parry*

SECOND READER

*James K. Hartman (KRTMG)*

CHAIRMAN, DEPARTMENT OF OPERATIONS RESEARCH

*Jack R. Poulson*

ACADEMIC DEAN

## ABSTRACT

This thesis discusses design considerations for Lanchester-Type Models of Warfare (LATMW). It establishes a framework for setting minimum design standards for such combat models. We formalize these considerations in a Minimum Evaluation Framework (MEF) for combat models. The state-of-the-art for models is briefly reviewed and major pitfalls in modelling combat are sketched. We show how to avoid such shortcomings by following our MEF specifications. Modern combined arms forces are abstracted as coherent systems of complementary and supplementary components. We derive a method to refine Lanchester Attrition-Rate Coefficients (LARC) as system capability measures by additionally considering reliability and availability weightings. Examples are given to demonstrate the implementation of these refined LARC quantifications in LATMW.

## TABLE OF CONTENTS

I.	BACKGROUND AND INTRODUCTION.....	8
II.	GENERAL MODELLING CONSIDERATIONS.....	13
	A. MINIMUM EVALUATION FRAMEWORK (MEF)	
	FOR COMBAT MODELS.....	15
	B. MAJOR PITFALLS IN COMBAT MODELS.....	24
	1. Performance driven Models.....	25
	2. Inconsistencies in Models.....	28
	a. Aggregation, Suboptimization,	
	Complexity.....	29
	b. Measurement - Scale Problems.....	36
	(1) First Example for Pitfalls	
	in Measurement Scales.....	39
	(2) Second Example for Pitfalls	
	in Measurement Scales.....	41
	(3) Regression on Dummy Variables...	43
	(4) Identifying Soft and/or	
	Hard Properties.....	45
	c. Cost Effectiveness Evaluation.....	48
	3. Documentation and Credibility.....	50
III.	SPECIFIC MODELLING CONSIDERATIONS.....	52
	A. LATMW AND THE MEF.....	54
	B. QUANTIFYING MODEL INPUTS.....	60
	1. Effectiveness of Combat Elements.....	60
	2. Hardware Systems, Human Interface,	
	Combat Environment,	
	Logistics Interface.....	67

3.	From Binary Numbers to Estimable Rates...	71
4.	The Final Concept of Estimable Rates.....	74
C.	ESTIMABLE RATES AND REFINED LARC	
	QUANTIFICATIONS.....	79
D.	MODELLING EXAMPLE TO GAIN ESTIMABLE RATES....	83
1.	Objective and Worth of Logistics.....	83
2.	Performance Description of Supply	
	in Materiel Classes and Categories.....	84
3.	Performance Description of Maintenance...	85
4.	Performance Quantification.....	85
5.	Effectiveness and its relation	
	to systems.....	87
E.	LOGISTICS AND LIMITED RESOURCES.....	90
F.	HETEROGENEOUS FORCES AND	
	SUPPORTING WEAPON SYSTEMS.....	92
G.	COST EFFECTIVE DECISIONS WITH LATMW.....	93
1.	Input - Output Analysis.....	94
2.	Lower Bounds for Force Postures	
	and Commodity Levels.....	97
3.	Inputs for Transaction Tables.....	99
H.	A FIRST-CUT SECTOR LATMW.....	106
IV.	SUMMARY AND CONCLUSIONS.....	111
Appendix A: FORTRAN PROGRAM		
	FOR A SECTOR LATMW.....	115
	LIST OF REFERENCES.....	126
	INITIAL DISTRIBUTION LIST.....	135
	LIST OF FIGURES.....	7

LIST OF FIGURES

1. Minimum Evaluation Framework (MEF).....	21
2. Minimum Evaluation Framework and the Cone of Abstraction for Combat Models.....	23
3. The Square Law Formulation of Lanchester.....	53
4. Combat Elements as Coherent Systems.....	62
5. MOE for an Input-Output Table.....	104
6. Attrition Processes and Battle outcomes Abstracted with a Differential Model.....	108

## I. BACKGROUND AND INTRODUCTION

Commenting on the efficient achievement of military objectives, Hitch and McKean have stated that: "Strategy, technology and economy are not three independent considerations to be assigned appropriate weights, but interdependent elements of the same problem. Strategies are ways of using budgets or resources to achieve military objectives. Technology defines the possible strategies. The economic problem is to choose that strategy, including equipment and everything else necessary to implement it, which is most efficient (maximizes the attainment of the objective with the given resources) or economical (minimizes the cost of achieving the given objective) - the strategy which is most efficient also being the most economical"[1].

Development of nuclear warheads in the past decades challenged Operations Analysts to model and analyze the economic war potentials of the leading superpowers, the United States and Soviet Union. Kosta Tsipis presented in [2] a mathematical model that relates technological performance parameters (lethality of a nuclear warhead, accuracy of landing warheads) to the overall yield of destruction. The approach is to numerically combine empirical estimates (inputs) with their effective return (output) according to the micro and macroeconomic concepts of production functions (for exact definitions see [3], [4]). Valuing inputs by their costs permits determination of optimal input combinations for a given output. Further examination of isoquant and isocost curves (see also [3]) constitute the key aspect of cost effectiveness analysis. Thus, large scale input-output analysis (due to Leontief

[5]) in exercising the Electric Five Year Defense Plan System (see excellent discussion in [6]) is feasible. This methodology, proposed by the Office of the Assistant Secretary of Defense (Systems Analysis), utilizes production and cost functions, obtainable from input-output (or transaction) tables in a similar fashion as the Department of Commerce [7]. The Tsipis model and the Five Year Defense Plan System can therefore be viewed as basic methodologies for the application of Operations Research to strategic planning problems (i.e. as stated by Morse and Kimball, "applying the scientific methods to provide executive departments with a quantitative basis for alternative decisions regarding the operations under their control" [8]). The use of nuclear weapons form the backbone of the Shield/Sword doctrine of the NATO. The United States Government is able to estimate with scientific methods the hypothesized nuclear power, the Sword, in America's NATO committment.

The Shield or the strength of the General Purpose Forces (ground combat forces, tactical air forces and mobility forces; see [9] for definitions) as the second hypothesis of the doctrine faces heavy critiques. For example, "NATO's forces are maldesigned [10]"; "Proferred solutions to NATO's conventional force inferiority, derived from economic efficiency considerations, would at best release marginal resources to buy more of NATO's misstructured forces [11]".

Moreover the scenario for NATO and Warsaw Pact is affected by considerable changes still in progress:

1. Increase of the ground combat forces of the Warsaw Pact since 1968 (military personnel plus 22%, tanks plus 40%, artillery plus 60% [13])
2. Industrial potential change (for large scale war systems the industrial capacity ratio is 5 to 1 in

favour of the Soviet Union [13])

3. Management change in 1976: the choice of Dimitrij Ustinov as secretary of defense of the Soviet Union, known as an expert to successfully handle the Warsaw Pact's military industrial complex [13]
4. Restrictions in military budget planning for all NATO members in favour of other current competing and urgent public problems.

At NATO's semiannual spring meeting (1976), the foreign ministers of the fifteen NATO powers bluntly warned the Soviet Union that the continued arms build up of Warsaw Pact forces beyond legitimate needs for defense is pushing the world into an arms race of dangerous dimensions. They also pledged the determination of their governments to take measures necessary to maintain and improve the efficiency of their forces as an essential safeguard to the security of member countries, whether against military aggression or political pressure [14]. As a consequence, NATO gradually adjusts the Shield/Sword doctrine to the doctrine of the Triad: neither conventional, nor tactical nuclear, nor strategic nuclear forces may substitute each other; each component plays an adequate single role in their combined effort to guarantee deterrence.

The western defense management is therefore urged to quantify effectiveness of all alternative forces and weapons, i.e. analytical models with empirically based numerical descriptors of the outcomes of different strategies and tactics are needed that indicate how to cost efficiently solve these complex problems.

Available combat models that assess the sword of the Atlantic Organization have been questioned as to their ability to produce realistic estimates of conventional force

capabilities [12]. However, the combat modelling community is aware of such shortcomings and has identified modelling aspects that need particular attention [20], [21], [70]. Consequently, the following recent publications illustrate attempts at improving the state-of-the-art of combat models by addressing these problem areas: [15], [16], [17], [18], [19] and [70].

Alternative decisions concerning the General Purpose Forces affect highly scarce economic resources. Our work concentrates on formulating better inputs into large scale combat models using LATMW and to draw cost/effectiveness conclusions by exercising these models. In particular, we establish a Minimum Evaluation Framework (MEF) for combat models by considering the decision process that ensures the expected quality of answers that the top defense management seeks by means of analyzing results obtained from combat models. In other words, this thesis develops specific design specifications for such models. After developing our MEF we sketch the typical pitfalls observable in current models that could have been avoided by considering such specifications.

Examination of very simple Lanchester-type models like Lanchester's original combat formulations (see[23]) with respect to our MEF naturally reveals some shortcomings. We overcome these by our development of the Concept of Estimable Rates. More explicitly, we weight the performance oriented effectiveness quantification of General Purpose Forces' weapon systems (i.e. the Lanchester Attrition-Rate coefficients) by estimable reliabilities and availabilities. Our first refinements for these measures of effectiveness however, remain still based on hardware performance. We view therefore modern weapons of combined arms forces as coherent systems with additional components such as human operators, i.e. their behavioral effects (morale, suppression,

decisions), environment of deployment and logistical consumption for example. A simple procedure to gain their estimable failure rates is explicitly presented, i.e. we show how to utilize war games, simulations, field or map exercises, experiments, operational tests, built combat models, military judgement or war data. These formulations allow us a fairly extended refinement of Lanchester attrition rate coefficients by reliability and availability weightings. Consistent abstractions of complex and interactive factors describe the worth of weapon systems in modern warfare scenarios. Simultaneously all specifications of our MEF for combat models are satisfied.

These new design considerations for LATMW produce refined Lanchester attrition-rate coefficients that are also numerical inputs for costed system effectiveness quantifications useful in an Input-Output analysis, i.e. we investigate our refined Lanchester attrition-rate coefficients and develop a method that extracts from these effectiveness quantifications (i.e. Net-operational times) for force postures, commodity levels, and for the elements of the net-output vector as inputs into the transaction tableau. A first-cut sector theater level differential model is added that delivers with our improved modelling formulations, if exercised, alternatives for given hypothetical scenarios that can be costed out. Finally, we suggest topic areas upon which future research, model building, and operational testing should focus in order to provide better inputs for LATMW. This will hopefully allow to scientifically abstract combined-arms operations in combat models.

## II. GENERAL MODELLING CONSIDERATIONS

The deployment of strategic nuclear warheads may be relatively easy analyzed with respect to their physical effects (for a thorough and detailed discussion see [2]). Conventional forces, on the other hand, perform as a combined arms team. Large numbers of weapon systems complement and supplement each other. Besides of the coordination of hardware systems there are also many soldiers of different branches required to manage these systems effectively. Their decisions and behavioral responses in different combat situations influence highly the course of actions. Assets for these combined arms teams, i.e. for their hardware systems and for the operating personnel have to be coordinated at a very high level. Therefore, one has to quantify measures of effectiveness (MOE) for combat systems that express the contribution of all components to the system's worth. It is only when we view a very large unit (the systems organized as divisions or a corps) that we can realistically portray large scale combat interactions. We have to be more articulate, for example, what large scale and interdependent battle process in physical terms really mean. The Table of Organization and Equipment for only one armored division lists numbers for personnel in the order of thousands and for weapon systems in fairly multiples of hundreds. Even, if a division is labeled as an armor division, all mission direct and mission support units with various specific technical equipment and trained skills are present in one armored division. The focal point of such a division is naturally the tank, but one shouldn't underestimate that its main strength is highly dependent upon the coordinated and

combined efforts of all branches. The effectiveness of the phalanxes of today's nonnuclear forces is not only some function of their main weapon systems, but also that of many support personnel. The combined arms effort in a large scale scenario is produced by many similar and different organized combined arms divisions.

Keeping only brief indicators of modern forces' structure in mind, it is obvious that engagements with opposed forces constitute very complicated processes on a battlefield that covers huge geographical dimensions. We have to abstract, aggregate and interpolate to scale ground combat down to a manageable size for military modellers. At the same time, analysis of General-Purpose-Force problems is much more sensitive to extrapolations from these artificially diminishing scales of the real world complexity. There are basically four approaches to modelling large scale combat between General-Purpose-Forces. War gaming, simulation, analytical (math) models, and any combination of these. Since the above combat modelling approaches have been discussed in detail elsewhere (see [20], [21], [22], [23], [70] e.g.), we will concentrate on requirements for any evaluative study of ground combat. Seth Bonder has said:

"...Combat models that are developed should contain a high degree of logical fidelity with the real world and, where possible, be isomorphic to it. Thus model developers are, in a sense, driven to the development of complex, highly sophisticated, detailed simulations of the combat process".

The author feels that a combat model should, moreover, be designed according to what questions must be answered in a defense planning study. Thus, the combat modelling community needs guidance for directing these modelling

efforts. What one builds into the model depends on many factors, the military situation, the combat elements, the available resources, including cost aspects, and the anticipated battle outcomes for example. For each combined arms operation we have to

-first, identify the major factors that contribute to answers to the addressed question in a combat model

-secondly, choose the scientific method that claims to represent most adequately combined arms effort and

-third, free these complex formulations of interactive factors from pitfalls often encountered in current modelling techniques, such as

1. performance driven
2. inconsistency in aggregation, suboptimization and complexity  
improper choice of
3. measurement scales
4. cost operational effectiveness relations.

#### A. MINIMUM EVALUATION FRAMEWORK (MEF) FOR COMBAT MODELS

All models, especially, those for military operations of Ground Combat Forces, must abstract from the real world. We now consider determining the lower bounds for such abstractions in combat models, i.e. the minimum amount of detail (or resolution) to be considered in such models. Micro and Macroeconomics faces the same problem. A perfect model for a free enterprise firm is, as such, impossible, just as a comprehensive abstraction of the entire economy of any country is not possible. Feasibility and tractability

are common features representing a single firm, aggregations, interdependence and connections of firms to the market or their subordinate roles in an economy that indicate their overall functioning. Since allocating scarce resources is the same motive power for micro/macroeconomic and military alternative decisions, we have to identify those components which are sufficient and also commonly accepted (as in the economic theory), as the main contributors for the functioning of complex military actions such as battles.

Classic Military Science developed its know-how basically from history and personal experience. After the second world war, empirical sciences gradually entered the scene as accepted and helpful tools for aiding military decision making and planning. [It should be noted that Lanchester's original work, as the first successful attempt to scientifically formulate combat problems, dates to 1914 and its use began after World War II]. It is therefore not astonishing that a critical overview of existing combat models may roughly be summarized as: they claim to assess, combined arms forces actions scientifically but are sometimes far off in doing so. Many others express similar critiques that ask for justification and proposals to improve the situation. Stockfish, for example, said in [21] p 128-129: "To obtain better insights into combat operations, hard thinking and testable models about tactics are necessary. However, this effort must be subject to and can be augmented by testing and other empirical endeavours related to activities that troops carry out".

It is the author's hypothesis that the shortcomings of current combat models are primarily due to the environment in which they are created. Unfortunately, decision makers never explicitly tell (and one does not expect them to) Operations Research analysts what should be included in a

model, much less establish tolerable or minimum bounds on the specifications for combat models. The observable circulus virtosus is this: the modelling community is asked to build combat models without being specifically provided with common facts that military experience could provide and which highly influence research objectives. Too much effort must be spent in adjusting different points of view. For example, every military commander appreciates tank performance capabilities, but, at the same time, he is also aware that high performance is only effective, if many other required environment conditions favour the deployment of tanks. Combat models start now gradually to formulate these type of actions and try to account for combined arms problems that really military planner and practitioner like to be analyzed. In 1967 one of DIVTAG's [41] six research objectives was: investigate the feasibility of combining tactical and logistical aspects into a single combat assessment procedure. Tactical und logistical aspects are immanent in any combat action. This research task could have been more articulate with respect to what logistical aspects should be formulated, if one had only remembered and analyzed General Eisenhower's statement "logistics influences all battles and decides most of them".

Before we outline our MEF for LATMW, let us consider a very analogous situation for abstracting combat processes. STANAG 2014 [45] provides the minimum amount of information necessary to derive military decisions for complex combat actions. Any military commander must be informed of the following:

1. Situation - enemy forces - friendly forces  
- attachments and detachments
2. Mission
3. Execution - concept of operation -general instruction

for mission accomplishment - organization of combat  
- miscellaneous instructions - coordinating  
instructions

4. Administration and logistics

5. Command and signal.

Given this information, a military commander can start to analyze the possibilities for enemy and friendly forces. The identification of alternative courses of actions and their relation to the scenario and mission depend on his decision process. The concluding phase of this analysis is to compare all alternatives and determine the "best" one. We observe that STANAG 2014 provides sufficient information to make an intelligent decision for any military action at any level of command.

Consequently, we take the above scheme as a point of departure for building combat models. We do so because it includes all data and information required to formulate (abstract) complex combat systems' actions. Therefore, every quantification of information that aids (viewed as a minimum) in describing combat interactive dynamics has to be present in combat models in a transparent numerical form, i.e. we call for mathematical descriptions that express the overall combined arms systems (organizations such as an armored division for example) performance and their effectiveness in LATMW. Thus, Situation (scenario), Mission (objective of combat action), Execution (doctrine and tactics), Administration and Logistics (allocation, consumption and replacement of resources) and Command and Signal (managing and coordinating techniques to lead units), as STANAG 2014's elements, establish a first set of a MEF specification that must be addressed with any combat modelling technique. In order to accurately predict combat effectiveness a combat model must also include the representation of the human interaction, i.e. the impact of

human behaviour, morale and decisions with regard to combined arms teams performance and effectiveness. As a military commander takes all these problems into account in estimating combat outcomes, a combat model must also represent such factors (and in a quantitative fashion). The next requirement for a MEF is that the dynamic nature of combat, i.e. the change of effectiveness of combined arms actions due to varying and interdependent effects of parts or of complete subunits, must be explicitly formulated. Furthermore, combat models have to be designed so that all allocated assets for combat units can be costed out and be compared with respect to their contribution to different battle outcomes. In the author's view, these are MEF requirements whose quantification must only be performed with the Scientific Method. Military concepts and logical rules are then testable and whenever possible verifiable and validable with empirical observations. It is obvious that combat prediction will almost have to be completely done without a large number of field experiments and operational tests because of their high cost. Furthermore, even field experiments and operational testing are extremely artificial because of safety restrictions. Representative military judgement based on history data and personal experience and realistic expectation may then serve as a helpful and consistent surrogate to obtain estimates without any degrading effect to the worth of the scientific approach. In essence, we demand from combat modelers that they use only verified and validated assumptions in formulating abstracted combat dynamics in a combat model.

We list now more schematically our MEF requirements that are applicable for modelling of combat, regardless of which modelling technique is chosen to abstract combat (Note that the framework for effective fire support analysis, lately published in [70] Appendix 2, may be viewed as an attempt to schematise the analysis procedure given that a combat model

exists that addresses our MEF specifications).

Minimum Evaluation (MEF) Specifications:

(1) Abstraction and numerical representation of interdependent combat elements, their capability, availability and reliability using the scheme of STANAG 2014 to describe combat element's performance (measures of performance (MOP)).

(2) Abstraction and numerical representation of the functional relationship between performance criteria and their effectiveness in the combat process to assess the systems' contributing worth, i.e. aggregate consistent MOP to measures of effectiveness (MOE) analog the concept of a production function on the data base given by STANAG 2014.

(3) Costing of the allocated scarce resources as inputs for alternative effectiveness criteria (outputs).

(4) Assurance of the simultaneous, repetitive and interdependent modelling of (1), (2) and (3) above and, not in parallel or in series.

(5) Representation of the human interface, either descriptive or presumptive, i.e. human behaviour and decisions are initiated by causes and influence systems' effectiveness at any time.

(6) Allowance for verification and validation in (1) to (5) above, i.e. Research, Development, Test and Evaluation (RDTE), history data and military judgement.

(7) Extend this MEF consistently whenever possible but don't diminish it.

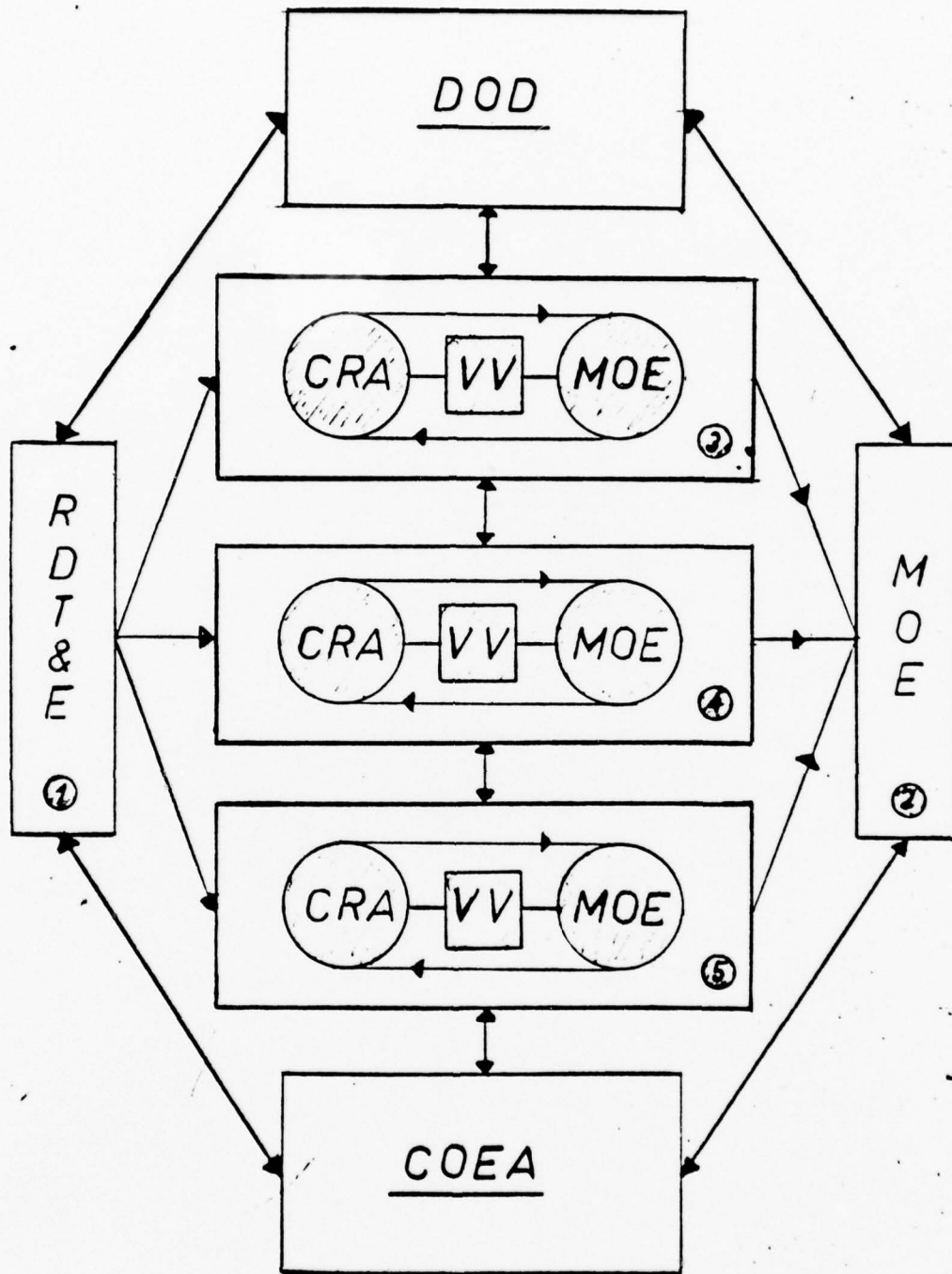

Figure 1 - MINIMUM EVALUATION FRAMEWORK

Fig 1 puts the MEF in a graphical context, the arrows indicating the interdependence of each factor. The figure represents only a snapshot of the necessary repetition and feedback of interactions over a continuum of action, either continuously or discrete assessed with respect to a time axis. The terminology of STANAG 2014 is marked accordingly by the ordering numbers of their headings and abbreviations are explained by the legend.

Legend for Fig 1

COEA = Cost Operational Effectiveness Analysis

CRA = Capability, Reliability, Availability

DOD = Department of Defence

MOE = Measures of Effectiveness

RDT&E = Research Development Test and Evaluation

VV = Verification and Validitation.

Fig 2 incorporates the MEF for combat models into the Cone of Abstraction (presented in [46] in connection with DYN TACS, which takes some of our proposed features consistently into consideration), indicating their value at any level (high or low resolution) and consequently at each level of command. Major pitfalls in current combat models, discussed in detail hereafter, are located where they might occur in this total MEF, thus yielding a complete management tool to decide whether or not combat is modelled consistently and sufficiently.

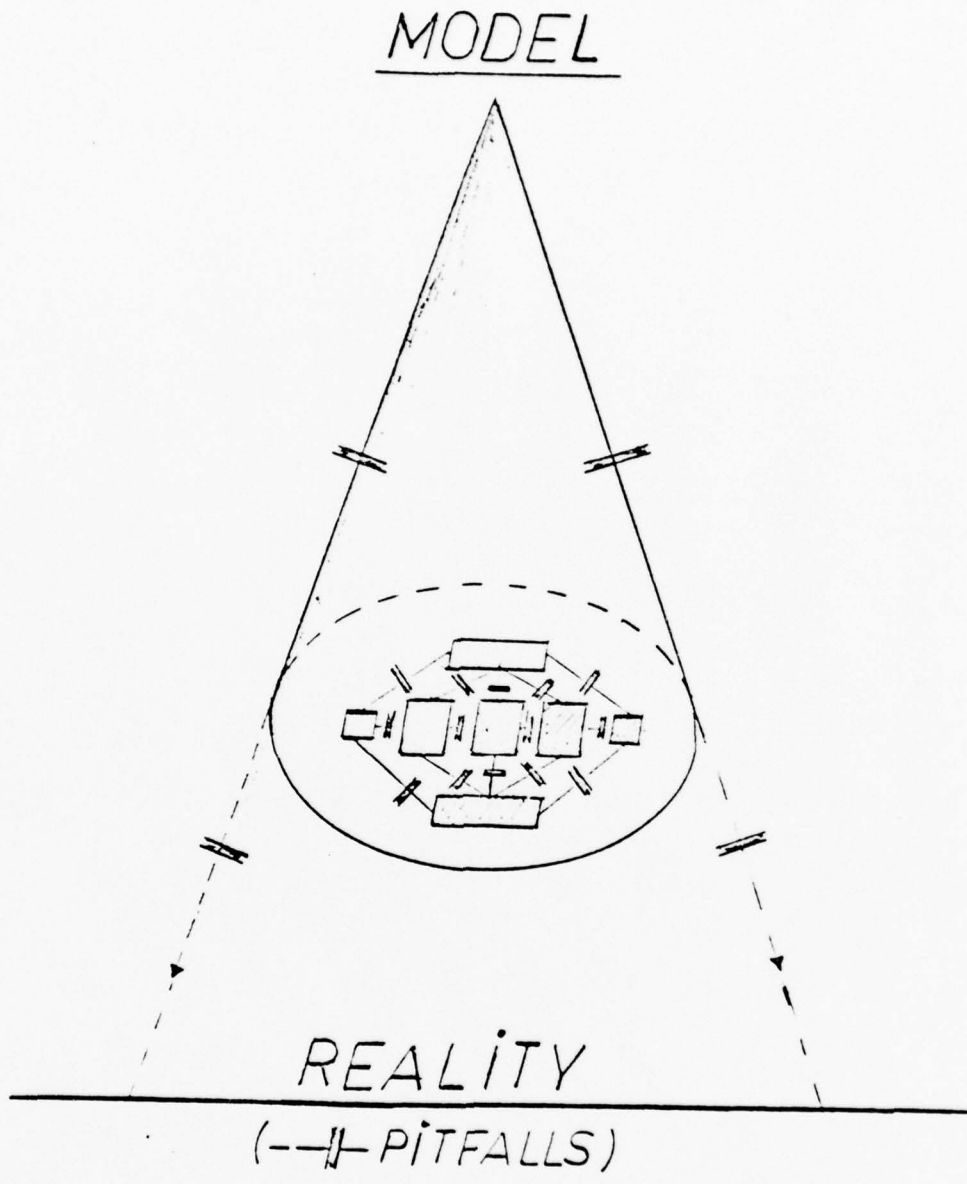

Figure 2 - MINIMUM EVALUATION FRAMEWORK AND THE CONE OF ABSTRACTION FOR COMBAT MODELS

## B. MAJOR PITFALLS IN COMBAT MODELS

Modelling ground combat at a very low level of resolution bears the danger to abstract and aggregate many combat interactions and duels of engaged units and branches in concise combat processes with unsound or unverified and unvalidated modelling means. Mathematical formulations, for example, may simplify sometimes combat dynamic descriptions to such an extent that inhearent features of a battle may either be suppressed or modeled with inadequate weights. On the other hand, in the attempt to overcome the problem of aggregating different levels of resolution one states assumptions in order to be able to model as much as possible of all identified interactions, at least as a rough-cut which by a further model development and compared to other modelling problems are viewed as first successful attempts to assist in formulating the complexity of problems at all. Finally, such a model gets completed and exercised to aid the military management in Cost Operational Effectiveness Analysis (COEA) studies. Military decision makers call for these combat models primarily in the belief that extended and detailed research and empiricisism rectifies all assumptions and formulations that went into the model. Managers hope in applying models to be able to assess combat at higher levels of resolution. They don't therefore expect modelling pitfalls in the abstraction and formulation of modern General-Purpose-Force problems with the aid of a concise model. We discuss now in detail major aspects that help to indentify shortcomings in models of which the most model users aren't aware of.

## 1. Performance driven Models

Technology changes altered the nature of combat. Modern technology provides capabilities. Tactics are designed to take advantage of these capabilities. The invention of the gunpowder replaced the duels of mercenaries with swords by fights that are determined by the skill to handle automatic rifles and the precision of predicting the time of a projectile's flight to the target. Cover and concealment protect now mainly soldiers that are far apart in fox-holes just like the shield prevented them from hits with sharp edges launched by very close opponents. More recent inventions and engineering efforts highlighted with radar, missiles, atomic energy, computer and lazer enable us to utilize highly technical equipment in modern strategies and tactics. We have the speed and agility of cross-country armored vehicles available to cross terrain that couldn't be passed by infantry-men or the possibility to acquire targets with infra-red sensors to fight in darkness, to name only some examples that lead to modern tactics. The main point, however, is that soldiers of today highly depend on the performance of their supporting hardware systems. This fact enforces modelling of technical performance in detail and introduces the dominance of hardware system considerations in combat models. Numerical expressions relate performance of these systems (in this connection only of weapon systems) to their capabilities. It is often assumed that all technical equipment is one hundred percent available and also one hundred percent reliable in the actual operational environment, i.e. the utilization of the performance capabilities is only always hypothetically available and reliable during the mission time. The extent to which a system may be expected to achieve a set of specific mission

requirements is not only a function of capability, but also of availability and reliability. Consequently, in overemphasizing measures of performance in models, questions that can only be answered by measuring systems effectiveness get a barely satisfactory answer. The nature of system effectiveness is a functional relationship of availability, reliability and capability in accordance with [66].

Since we consider differential combat models, or LATMW, we investigate the currently applied system effectiveness quantifications by examining Lanchester attrition-rate coefficients (LARC). Cherry gives in [70] Appendix 4 p 3-12, an explicit presentation of how LARC's for heterogeneous forces are formulated. For the  $i$ -th Blue group weapons that fire against the  $j$ -th Red group targets at a range  $(r)$ , the attrition coefficient for the Blue group is denoted by  $a_{ij}(r)$  (compare for more detail our First Example for Pitfalls in Measurement Scales). These attrition coefficients are claimed to be notably extended in a high-powered modelling sense. They are decomposed in several rates:

-rate at which an individual system in the  $i$ -th Blue group destroys live  $j$ -th group Red targets at range  $r$  when it is firing at them

-the allocation factor (proportion of the  $i$ -th group Blue systems assigned to fire on the  $j$ -th group Red targets which are at range  $r$ )

-the intelligence factor (proportion of the  $i$ -th group firing Blue weapons allocated to the  $j$ -th Red group which are actually engaging live  $j$ -th group targets at range  $r$ ).

Performance is inherent in these attrition rates and drives as a capability measure battle outcomes. LARC are

mainly assumed to be dependent on a multiple of physical parameters of a weapon system describing their capabilities. It is also claimed (without any explicit proof) that for any weapon-target pair values for attrition rates are obtainable that are related to properties such as concealment, cover, roughness, exposure, movement etc.. One is therefore forced to ask: Are there valuable and verifiable functional relationships available at all to formulate such a refined utilization of heterogeneous forces' capabilities? In the discussion of our First Example for Pitfalls in Measurement Scales we show explicitly why it is very important to direct this question to modelling approaches and techniques, and to the assumptions that lead to them.

There are two different basic approaches for estimating LARC's. One can use either the Bonder/Barfoot methodology (for a specific treatment see [24], [25], [26]) or the statistical maximum likelihood estimation from Monte Carlo Simulation outputs (Clark's methodology, see [27]). Both are performance oriented and allow only performance based alternatives for military cost effective decisions. If no sound methodology to refine LARC's exists (documentation of VECTOR-II doesn't show it), then we could only derive from these performance quantifications that drive battle outcomes in models estimates for systems which perform best assuming they operated without any failure during the mission time. The identification of those opponents that should be killed is one step in the plan to defeat enemies. More decisive however, is that friendly systems which are called upon to do this are at this critical time step reliable and available to fulfil this goal. The defense planning management is very interested in obtaining scientific estimates to identify alternatives in employing systems more reliable and available but less capable, as opposed to systems more capable but less reliable and available.

An armored weapon system also depends on a group of human operators to initiate, control and terminate highly automated performance criteria. How does their reliability and availability, i.e. their trained skills and their morale affect the system's performance over a course of possible actions? Performance parameters are very important system characteristics, but not the only ones necessary to predict and quantify systems effectiveness. Performance driven models can only satisfy (1), (4) and (6) of the MEF. We derive in our Specific Modelling Considerations a scientific method that relates detailed combat interactions, measurable in soft or hard properties, to an overall system's effectiveness for combat dynamics formulated with LATMW.

## 2. Inconsistencies in Models

Three major types of inconsistencies that frequently occur in combat models are

- aggregation of different levels of resolution;
- inproper choice of measurement scales;
- violation of cost effective analysis requirements.

The occurrence of these inconsistencies appears to be highly correlated, i.e. they usually occur together. They are sometimes triggered by the assumptions made in developing the combat model. We are aware that some problems are not studied and understood in detail and Combat Modellers try their best in using first-cut approximations and assumptions that are hard to disprove or to replace by more quantitative ones. The following statement is representative for this situation: "...we attempt to approximate what happens in a small period of time during a battle" [70] Appendix 4 p 4. However, we found in studying combat models that sometimes an unsound "attempt" assists "to approximate what happens".

More careful and scientific approved work could have produced better formulations and expressions that are based on verifiable and valid assumptions.

Another observation of the author is that no MEF requirements for combat models ask Combat Modellers explicitly to state what has been achieved with the Scientific Method and what are surrogates (no scientific approach is known yet) to answer the addressed problems in a combat model. There is a very qualitative difference with respect to the worth of conclusions drawn from models whether the results stem from scientifically valid modelling approaches or not. The freedom to choose any "welcome" or explorative "sounding" formulation to abstract battle dynamics has to be limited to only scientifically valid ones, if one chooses analytical models as an overall framework to assess combat activities.

a. Aggregation, Suboptimization, Complexity

We discuss now pitfalls that are mainly discovered in aggregating different levels of resolution in one complex model. The three main problem areas with this regard are

- inconsistent combination of  
different modelling techniques and aspects;
- deriving aggregated decisions  
from suboptimal aspects;
- considering too much detail,  
where more proper abstraction  
could represent the complexity.

High resolution models (see Fig 2) utilize contingency plans on either a One-on-One or One-on-N basis for engaged systems. Low resolution models concentrate on battle outcomes for M-on-N engagements. A very common approach to overcome the high-low resolution gap in assessing effectiveness is to use submodels that depict, performance characteristics for One-on-One engagements, aggregate those with an approximation, and use these as inputs for low resolution models. If the same contingency and model conditions hold in both (but different levels of abstraction), this may be a valid surrogate for modelling and analysis purposes. However, combining different modelling techniques that address different levels of resolution yields unpermissible aggregation in a model despite its various sensitive effects.

The current, most developed and advanced family of differential combat models [also being the most used and believed to be the representation of the state-of-the-art (see [70])] are the VECTOR models [42], [43], [44]. Their approach to allow detailed information (which matches most STANAG 2014 elements) to describe heterogeneous forces actions (compare [44]) is to specify state variables with different values expressing:

1. battlefield
2. environment, time
3. forces
4. supplies
5. plans and intensions.

So-called major models, such as for command, control, communication, intelligence, target acquisition, firepower, logistics and supply, movement, etc. are claimed to compute, for weapon-target pairs, the corresponding attrition rates

for heterogeneous opposing forces at any time step a battle is predicted. For the computation of the LARC estimates of times and probabilities to kill a target, as appropriate measures, which will be required to destroy the target, presumingly including all the other conditions of the battle, are used to apply the Bonder/Barfoot methodology [24], [25], [26], to determine the attrition rates.

Consider, for example, how in a major submodel logistics and supply is evaluated. It is true that the analytical development for LARC of Bonder/Barfoot allows us to relate the time as a random variable  $T_{ij}$ , i.e. the expected value of the time of the j-th weapon system to kill the i-th target at a range r, to the number of rounds of an ammunition type fired to kill a target (see explicit treatment in [81]). It is also true that on this data base, the amount of ammunition resources expended, i.e. the costs for the number of rounds fired to kill a target, can be computed per weapon system, per time, and per location. Inconsistent aggregation however, is to determine ammunition consumption at this very high resolution level, but to model resupply by means of tactical decision rules which allocate all supplies by type from theater to sector and from sector down through the command and control hierarchy to maneuver units without explicitly using a logistics network. Logistics' decisive role is assessed with inconsistent modelling techniques. The demand of ammunition is generated at a high resolution. Logistical decision rules have to determine in a much less detailed form the allocation of needed resources. Without representing the flow of materiel explicitly through the command hierarchy, decision rules could only assume that ammunition is distributed uniformly, for example, among all weapon systems of the lowest member in the represented chain of command. How can these simplifying decision rules, to be implemented into a model

according to preselected decisions, react in time and immediately degrade weapon systems effectiveness of those units that are not supplied sufficiently if shortage occurs?

A second inconsistency is also committed: weapon system attrition in VECTOR models is determined by time and location of the duels with the aid of a digitized map. Only a logistics network would allow the same resolution to determine which consuming maneuver unit is how long and by how much affected by successful "coups" (unpredictable with decision rules) of enemy interdictions. It is not obvious at all how the undoubted delay of deliveries of goods and the tremendous reduction of available resources caused by enemy interdiction is adequately formulated, if different levels of resolutions of modelling techniques are combined. We would like to point out that we therefore have reason to believe that closer examination of other major process modules would reveal similar inconsistent aggregations.

Quantifying only system performance in models and aggregating these with inconsistent modelling approaches will never allow one to scientifically and quantitatively assess the effectiveness of interdependent combat elements. Let us elaborate further, to address logistical problems with a major logistics and supply submodel (similar to that we discussed above), one could have equivalently stated the following assumptions and modelling procedures: (1) deployed weapon systems are one hundred percent reliable and available during the mission time; (2) operating systems are allowed to consume their supplies without any restrictions; (3) only weapon system capability degrading effects are modeled that are caused by interdiction or shortages due to limited resources; (4) these degradings are computed in adjusting LARC "somewhat" (where are better estimates in the above major submodel called logistics and supply?) at a later timestep, if interdiction is recorded or shortages are

noted.

In other theater level combat models a different type of inconsistency in aggregating logistical aspects (in a later chapter we define these explicitly) may be observed. Linear and Nonlinear programming ([32], [38], [39], [83]) offer a variety of computerized algorithm for determining the optimal allocation of logistical resources. Such subroutines are frequently used in combat models and assume rational decision makers, i.e. only some constraints which wouldn't change accordingly to sudden variations that are due to combat activities are modeled. They may compute, for example, within this limitation minimal routes for supply trucks or maximal allocation of required supplies by tons and type in time and location (see [15], [16]). Before we continue to discuss the next type of inconsistency let us give three remarks with respect to optimization methods in combat models in general. (a) Exercising optimization subroutines in models cover the most costly part of a model production run (see e.g. [40], [41], [42], [43], [44] and [97]). (b) Optimization methods are very suitable modelling tools also for other than logistical aspects (e.g. to determine optimal routes of advance or identifying high priority targets - see an excellent overview of this topic in [70] Appendix 6). (c) So - called quasi optimization methods (see e.g. [97]) try to approximate mathematical conditions ("Kuhn-Tucker", see for more detail [38]) with unsound methods (see explicit proofs in [98]) that don't yield optimal solutions for any problem. Thus, combat models which utilize such procedures can't claim that their model outputs are optimal ones.

In the author's view it is primarily the computational-cost impact (computer time) of optimization methods in models that model builders carries away to what we now call inconsistent suboptimization. In logistics and

supply models, allocation of resources is optimized subject to detailed constraints, but their overall favouring or degrading influence is aggregated in single measures as tons, kilometers, etc.. They are then again aggregated into functional relationships expressing the mismatch of demand and supply proportional to total numbers of consuming systems in a sector, neglecting constraints at all. Costs for computer time may increase with the growing complexity of optimization procedures implemented in models. The trend to decrease them only in aggregating two different levels of resolution (optimizing only one modelling aspect and combining these results with formulations that neglect similar considerations in exploring the worth of these suboptimal results) is inconsistent suboptimization, and as such an unsound modelling attempt for an overall complex and aggregated problem.

Although aggregation and suboptimization are sometimes accompanied with measurement-scale inconsistencies that we discuss later, we would like to point out that one inconsistency either with respect to aggregation or optimization is often the cause of all these inconsistencies together that destroy the total quality of models. They may still be the "best" models that we currently have because they use other very high powered modelling techniques that are very representative for the state-of-the-art.

The complexity of General-Purpose Forces in a Theater-Level Campaign, and the need to represent as much as possible of combat environments, forces us to split up problems into a feasible and manageable size in a combat model with the assistance of subroutines, preprocessor models or other supplementing inputs. Evolution of the VECTOR series claims to be: "characterized in one respect as involving a continual decrease in the number of processes that are decoupled from the combat viewed from the

theaterwide perspective" [70] Appendix 4 p 35-36. Inputs for battlefield and environment discrimination, for example visibility, trafficability and weather, may be specified with state spaces at four levels for five days. This claim holds only in accordance with this statement: "subject to constraints imposed by computer storage and running time, some activities whose effects are less immediate are calculated periodically, but efforts have been directed toward the objective of including all interactions simultaneously whenever feasible" [70] Appendix 4 p 34. The problem to address the complexity of ground combat in models is not resolved satisfactorily. In describing modelling techniques of a complex model, in [70] for example, one is forced to the following contradiction: "Ideally, there exists some functional relationship between the results of a battle and the initial numbers of forces, types and capabilities of weapon systems, the doctrine of employment, and the environment... Unfortunately it is not known how to construct such a function directly, nor is there sufficient data to develop it" [70] Appendix 4 p 4. If neither analytically nor empirically relevance permits us to specify minimum state spaces and their levels, why are exactly four visibility and trafficability types chosen to sufficiently model this phenomena? The next natural question we focus on later is: Which numerical values are used, i.e. in what units and origins of measurement scales are these numbers?

Combat modellers are faced with the following dilemma: The model user and consumer ask for detail for which they themselves can't give explicit directions verified and validated by models. Some feel exists, we have to represent this and this... (e.g. Command, Control, Suppression). Model builders are then naturally forced to use any formulation as a rough-cut (there are no indications what is wrong or better), which are in some sense exploratory, but not verified and validated for applied

analysis to assist longterm strategic and economic decisions. The main investment for future research should be to develop modelling methods that allow us to establish sound formulations usable as low resolution modelling approaches which at the same time aggregate very detailed high resolution information.

b. Measurement - Scale Problems

In our MEF we require in (1) abstraction and numerical representation of interdependent combat elements' performance, availability, and reliability. Combat elements that are modeled are also required to match the information scope of STANAG 2014. Therefore, one has to start out from these MEF specifications and to try to find formulations that address not only one, but all these aspects together. The required amount of detail is given by the level of resolution that is expected from a model. Without violating these bounds interdependent combat elements may be slightly different, but more effectively categorized to be abstracted in components, i.e. they may be viewed as coherent systems of:

Hardware Systems Performance

Human Behaviour and Decision

Environment Conditions imposed by

Nature and Scenario

Economic Potentials to manage these effectively.

Combat modelling asks one to abstract and numerically represent these categories and to analyze their individual and interdependent contributions toward a desired combined

goal. The state-of-the-art is pretty advanced to abstract and numerically represent physical hardware systems. The quantifications of the costs of their assets and their production have impact on the economic potential of a country. Estimates for these costs are the government expenditures, in dollars per year for example, that have to be spent from the Gross-National product per year. This costing procedure is relatively easy and therefore widely used in defense planning studies (Note that no life-cycle-costs, e.g. are considered with this method). More complicated however, is to develop dynamic cost relationships for military systems (e.g. how are life-cycle-costs defined in consense with the cost definitions of the traditional or modern micro and macroeconomic theory? - see [34] and [35]). Sometimes cost analysis studies are performed with unsound methods and we will focus on this point in more detail later. Combat modelling has to deal with very different types of quantifications, for example, system costs, system performance and effectiveness, and the influence of human beings and environment conditions on battle processes. We are aware that all these necessary quantifications of complex combined arms operations involve tremendous efforts and resources. The final product of these abstractions are numbers to be used as inputs for analytical models. These numbers however, are in different units and origins and we found that this leads to measurement scale problems that might be viewed (compared to the scope of questions that is addressed in combat models) as "minor" or "secondary" ones. Moreover, only few methods are available to extract from soft data (in a nominal, ordinal or interval scale) scale values in a ratio scale which could relate human behaviour and decisions or combat environmental conditions to performance measures of systems which are in a ratio scale. If a number gets assigned to quantify an instance of a property of a component of a combat element it is not

necessarily evident that limitations are imposed to perform mathematical operations with these numbers. Since most models are mainly concerned with performance evaluation of hardware systems it appears to be a redundant analysis to doubt numerical quantifications, and performed mathematical operations, on those numbers that try to abstract human and environmental interface for example. In the author's view the main danger in committing pitfalls without being aware lies in inconsistent aggregation of different measurement scales. Therefore, detailed analysis is devoted to this point. We start considering shortcomings in models with respect to measurement scale problems. The investigation of a built and an advertised model will also show us how inconsistency in measurement scale aggregation will lead to a multiplicity of pitfalls and/or shortcomings.

We identify two main problem areas:

-How to extract from soft information scale values that follow a nominal scale (only classification is indicated), ordinal scale (order or ranking is expressed), interval scale (equality of intervals is only satisfied) or a ratio scale (equality of ratio holds)?

-How to consistently combine information present in different scales?

In order to resolve some of these problems we discuss the method "Regression on Dummy Variables" (see [31]) and sketch their limitations imposed due to the state-of-the-art. Finally, in only using Dummy Variables we offer a powerful method to extract from soft and hard information numerical values in a ratio scale that can consistently be incorporated in combat models (Note these information quantifications for real world problems will be the basis for our Concept of Estimable Rates that will allow us LARC refinements to any wanted detail).

(1) First Example for Pitfalls in Measurement Scales

Bonder/Barfoot's freestanding analytical model for the LARC offers a method to gain the most critical coefficients needed as inputs for LATMW. The reciprocal of the mean time a firer kills his target at a range (r) defines the LARC. This analytical formulation includes the following factors (see [70] Appendix 4 for implementation in VECTOR-II):

- time to acquire a target
  - time to fire a first round
  - time to fire a round following a hit
  - time to fire a round following a miss
  - projectile flight time
  - probability of a hit on a first round
  - probability of a hit following a hit
  - probability of a hit following a miss
  - probability of destroying a target given it is a hit
  - probability of destroying a target given it is missed
- (compare for detailed development [81]).

For weapon systems that utilize single shot Markov-fire one can only obtain estimates for these quantities based on hardware characteristics of systems that are employed at different ranges (r).

Moreover, consider again the four visibility and trafficability types to account for

additional environment conditions to refine LARC in the VECTOR-II model. Our questions are:

Which regression model, or what linearly independent estimable functions, tell us that only four visibility types are significant (if any acceptable linear combination of factors or their levels exists at all) to analyze the phenomena, and if so, which measures have been chosen to represent these numerically? Footcandles, day, night, dawn, fog?

What is their value as state variables of the state space for attrition process submodels?

How is this analytical relationship formulated in context with the LARC?

Since no detailed documentation is available that would allow us to explicitly prove the committed pitfalls we can only indicate with the above questions how inconsistent aggregation and mix with measurement scales has been performed. The danger of these shortcomings lie in the possibility that by the choice of arbitrary origins for units (who decides which are the proper one's?) any desired model output can be yielded by simply tuning some inputs (-scientific method?-).

For example, if only the numerical representation, i.e. the choice of the wrong scale of measurement, is other than a ratio scale for weather, then (1), (2) and (4) of the MEF requirements are violated by the use of a math model. It is only on quantities allowed that yield ratio scale values to perform all mathematical operations. The unique origin of their scales relates all numerical expressions consistently. Thus, measurement scale pitfalls are likely to subsume the total spectrum of

inconsistencies and distort any further credibility of a scientific verification and validation. We would be delighted to see that the state-of-the-art in combat modelling is far more capable as we have hope to believe.

(2) Second Example for Pitfalls in Measurement Scales

The very careful documentation of [97] allows us to present this example in detail: It is assumed that weapon systems capabilities are expressible in dependence of their supply requirements. Nominal supply requirements measured in tons are known and denoted for each battalion as NSR (nominal supply requirements). An optimal allocation procedure (e.g. for transportation problems see [32]) allocate supplies from depots to each battalion, denoting these as AS (allocated supplies). Some scaling factors proposed by military judgement are denoted C1, C2, C3 (coefficients 1,2,3) respectively. The relative battalion availability factor is denoted as BAF and is related to the following quantity:

$$BAF = C1 [1 - \exp(-(C2 AS)/TNSR)]^{C3}$$
, where TNSR equals the number of battalions times the nominal supply requirements (total nominal supply requirements).

The choice of the exponential relationship is rectified by the goal of this model, namely to inquire about the relative availability of the number of weapon systems used or, in probabilistic terms, to evaluate the probability to be effectively equipped with a certain amount of weapon systems simultaneously over a period of time. Examination of this equation reveals:

(1) For C1 = 1 the expression behaves, for any values of the other coefficients and the independent

variable (i.e. the quotient of AS and TNSR), like a cumulative distribution function.

(2) For  $C1$  not equal 1 these quantities may reflect that, if  $C1$  is greater than 1, better than, and, if less than 1, worse than 100% performance capabilities, if more or less than 100% supplies are available. The temptation is great to interrupt further analysis at this point and to incorporate this structure of information into a complex model. What is really accomplished? To hold the ratio of cumulative amounts (available supplies, required supplies) constant permits any linear combination of different supplies available and/or any linear combination of different supplies required. The law of perfect substitution of needed ammunition (AMMO) for petrol oil and lubricance (POL) would have then to be true. If we don't allow for linear combinations of AMMO and POL and treat each supply type separately, then we are faced with the problem of what one-to-one relationship permits us to trade AMMO types and/or POL types with respect to performance capabilities, i.e. what model do we use that would compute trade-off alternatives that for example twenty tons of AMMO for artillery units are equally effective than fifty tons of AMMO for armor units? We have only weight or type quantifications of goods available that are undoubtedly necessary to manage huge amounts in transports. Preferences attached to these numbers permit us to at best rank different materiel classes or categories and to extract from these scale values in an interval scale. No relationship exists that could tell us by how much one ton of goods is more effective than another of a different materiel category or class in a specific combined arms action. The lack of these relations is one cause for the critique to use Firepower Scores in combat models (see [20], [21]). Our example model however, claims to be more sophisticated and credible as this widely questioned modelling attempt, if

used for sensitive analysis. In aggregating values that belong to different scale value classifications we lose, as our example reveals, scientific grounds. No perfect substitution of supply goods is feasible and we conclude moreover from ordinal numbers more as we are allowed to do (see excellent treatment of scaling methods in [100]).

Next, to show that our example expression is a distribution function for some random variable, we must prove that four specific requirements (compare e.g. proof in [33]) are satisfied. It can easily be shown that some of these are violated for particular choices of  $C_1$ ,  $C_2$ ,  $C_3$ . Therefore, to choose coefficients in such a way that probabilistic mathematical requirements are satisfied may be especially questionable, if these choices are interpreted after being held fixed for modelling convenience as empirical surrogates obtainable by military judgement (compare e.g. [16] p 535 in this connection).

As a result we would like to emphasize again that the choice of modules (may they be the simplest and most plausible ones) must be sound with respect to transformation and operator requirements imposed by measurement scales. A model can with shortcomings of this nature be driven to biased results that model builder and user never intended and which any derived analysis never gets rid of.

### (3) Regression on Dummy Variables

Statisticians are well aware of the inconsistencies that might occur in mixing or aggregating different measurement scales. They focus only on those properties of a soft information (in an ordinal, nominal or interval scale) that are also common to a hard information (in a ratio scale). Instead of worrying about different

origins and the units of measurable instances of a property, they restrict themselves to the observations of states in which a soft and/or hard information can be categorized. More specifically, instances of a property at different levels are either observable or not apparent. The quantification of the possible state space is performed with the binary numbers one or zero respectively. Therefore the space of instance outcomes forms a set of Bernoulli variables with dummy outcomes one or zero (these numbers are on a ratio scale).

We see the importance of this approach in the possibility of being able to consistently analyze soft properties of complex systems that also have characteristics measured on a ratio scale. Combine vectors, whose elements are only zeros and ones, obtained by experiments, simulations or military judgement to an incidence (or design) matrix denoted by  $X$ . Formulate the hard and soft characteristic relation hypothesis as a general linear regression model, not of full rank, denoted by the matrix quantity  $Y = Xb + e$  ( $e$  indicating the error terms).

Analogous to regression on balanced or unbalanced designs of systems whose component instances are completely measurable in a ratio scale mathematical statistical theory delivers sound methods to solve normal equations of the general linear hypothesis. As Searle in [31] p 180-224 and others explicitly show, linearly independent estimable functions exist which allow to explore the system's structure under consideration (see for explicit discussion [94]).

We would like to emphasize that some applications of this methodology are known in military experiments (e.g. in the ASARS II Study at CDEC [82]) and studies exist that particularly address this technique to

military experiments (e.g. [99]). For completeness, we also would like to point out that the state-of-the-art to obtain linearly independent estimable functions is "trial and error". We strongly believe that further research work can yield other than "trial and error methods".

Regression on dummy variables is one method to explore more efficiently the impact of soft information in systems than it is now done in most combat models. However, since the structure of linearly independent estimable functions may restrict the interference initially intended to obtain we depart from this methodology with respect to the model formulation used to extract wanted information.

#### (4) Identifying Soft and/or Hard Properties

In contrast to the questionable approaches to account for more detail in formulating combat interactions marked out in the above two examples, we use now the dummy variable representation of system characteristics in a slightly different way. Let us view dummy variables as binary variables or Bernoulli random variables with the only outcomes zero and one. Thus, experiments, tests, simulations and representative military judgements are only asked to identify absence or appearance of states of a property or of a component of a coherent system (e.g. absence or appearance of a critical supply good, a crucial weather condition, an important intelligence information or an assumed human behaviour). These state outcomes of properties (i.e. quantifications of instances of properties) may either be predicted, observed from indicators, exactly measured or simulated. In order to assign the values zero and one consistently to identified states we state that functioning of components is the desired situation and components' failures degrade system's

worth regardless, whether their appearance or absence is critical with this regard. Hence, assign one, if a component fails and zero if it does not.

This procedure allows us to consistently aggregate soft and hard information. We are able to specify the level of resolution in accordance with the level of analysis that we expect to perform via the combat model. Interdependent combined arms force's elements have been abstractly categorized as components of coherent systems. This scheme combined with identified states will serve as the driving vehicle to start to formulate the Concept of Estimable Rates to refine estimates for LARC. Since we pursue the idea to view combat elements as components of a coherent system in more detail later we focus now on problems that arise, if unique or unanimous state identification may be doubted, i.e., if the instance of a very soft, but combat relevant property is judged differently by military experts.

Soft and/or hard information quantifications, in instances and/or scales respectively, have to follow exact rules for numerical computations imposed by the definitions of different measurement scales (see for a thorough treatment [30], [31], [80], [84] and [85]). Consider for example the soft property "initiative of a military leader". How can we get numerically a handle on this human feature that is claimed to be necessary to successfully lead troops on a battlefield. We formulate the nature of this problem for illustrative purposes very general and assume that  $(m)$  instances of this property are sufficient to decide that a military leader possesses initiative.

Cite  $(n)$  military experts ( $m, n$  being integers) and ask them to consider each of the  $[n(n-1)]/2$

possible pairs of instances, and within each pair, to split (divide) one hundred points. For example, if one judge perceives that instance (x) will be three times more required than instance (y), he might allocate seventy-five points to (x) and twenty-five to (y). Comrey developed a method for Absolute Ratio Scaling (see [84]) that produces least-squares estimates (see [80]) for the ratio scale values of each instance. The assumption in this "Constant Sum Method" (see [100]) is

-the choice of the unit for the scale values is arbitrary, therefore we choose one such that the mean of the natural logarithm of the scale values is zero (Note that this is equivalently as to assume that the error variable of a linear regression model has mean zero and a finite second moment, i.e. no specific distributional property for the error variable must be specified; see e.g. [31] and [80]). A monotonic similarity transformation to the least square estimates of the scale values can yield others on a new scale zero - one. In order to distinguish between more or less important instances we introduce a convenient dividing line on this zero - one scale. The last step in this procedure only requires us to assign values that lie above the chosen dividing line (according to our rules, zero; they are functioning or contributing instances) and to those that lie below this benchmark (i.e. one).

In a summary, whenever a soft or hard property causes difficulties with respect to identification of system states, we apply the very straight-forward Constant Sum Method. Scale values produced by this technique are put on a zero - one scale and we gain by introducing a judgementally determined benchmark estimates (statistically best linear unbiased ones) that deliver scale values for instances of properties. Their values can be transformed to the numbers zero and one and are naturally in

an absolute ratio scale. For these numbers all mathematical operations are allowed.

### c. Cost Effectiveness Evaluation

In a variety of studies relative relations (i.e. not the individual values of variables under consideration, but only their ratios) are very useful to gain insight into very complex problems. As the work of Taylor and Parry in recent publications [18] and [19] particularly for combat models shows, the use of LATMW in simple formulations has been tremendously enriched in this direction.

Along the lines of problems of inconsistencies in measurement scales, however, is the use of so-called cost effectiveness ratios, especially when combat model outputs are combined with costing or budgeting considerations. The economic impact of the application of these type of ratios forces us to devote a separate paragraph to the subject as their general deficiencies are covered by incommensurability problems of measures in different units.

The recommended procedure to solve cost effective problems is to use the effectiveness ratio, which divides the cost of the system by a number which may be obtained from the models representing its relative effectiveness and then chooses the system with the smallest ratio. This methodology can lead to deceptive conclusions, if numerator and denominator are incommensurable by the nature of their measurements respectively. Costed inputs are only comparative with costed outputs (see [57]). To pursue cost effectiveness with the ratio approach, which might only be assisting in exploring some trends, is only adequate, if great care is taken in analyzing the process under examination. This difficulty is explainable by the

inherent lack of most of the combat models to permit cost effective analysis directly with model outputs (see e.g. [59]). One reason for this is their pure performance orientation, i.e. some criteria of the MEF are not satisfied. The main reason lies in the methods commonly used, but in an unscientific way, to resolve decision processes in the defense management area. The department of defense in almost every country may be viewed as the single enterprise which consumes the most economic resources at the same time having the least developed cost accounting system that would allow cost effectiveness analysis. Compare for example [6] p 365: "Because the costing procedure has not been stated in an explicit and reproducible manner, the dialogue between the Secretary of Defense and the Services will be far less concise".

Military budgeting procedures are different from industrial costing procedures. Budgeting of public goods, in general, lacks the counterpart revenue encountered in financial accounting systems applied in the industry. Yet, both goods (public and industrial) to be costed out have the same problem nature in common: to effectively allocate scarce resources to yield outcomes.

Economic order quantities (EOQ) examined for cost effective alternative decisions, for example in industrial Inventory Control Theory (see [96]), cannot be used directly for expenditure alternatives of public goods. Foregone revenues expressed as costs of inconvenience that occur, if one acts against an avoidable prespecified critical and revenue degrading task are very unlikely to be easily (if at all) identified as costs for public goods.

We also like to note that the term "costs" usually is interchangeably used with expenditures in connection with public goods. This may lead to confusion, if

one nearly would mean that expenditures as costs can be earned by offering goods on a free-trade market.

The idea to apply cost effectiveness control in small or large scale for military investments dates back to McNamara. Up to now, this concept has not been fully implemented at all levels in military cost effectiveness considerations. In effect, Administrative Science has invested a lot with this regard. The following statement however, directs to further needs: "We must have the capability to rapidly cost out proposed alternative forces and to compare alternative costing methods" [6] p 367.

Our MEF requires, therefore, relationships that are usable for cost effective trade-off analysis. We will present later some ideas of how differential models can be utilized more effectively as it is usually done in COEA studies (see e.g. [57]) when we have established our Concept of Estimable Rates.

### 3. Documentation and Credibility

As Fig 2 indicates, possibilities for committing pitfalls in constructing models are spread all over the interdependent elements of the MEF imbedded in the Cone of Abstraction. The two examples given above for pitfalls in measurement-scale problems sketch the problems and doubts that may arise, if insufficient documentation for a model is provided. We appreciate the tremendous effort of man-hours and costs to produce a suitable documentation for a Theater Level Combat Model. However, how else can scientific statements about the modelling approach be tested, as by allowing to follow them through in a careful documentation. Furthermore, the scope, the complexity and the importance of the problems addressed with LATMW demand scientific complete

verification and validation. Trade-off alternatives may be derived with these models that influence the governmental budgeting procedures and have direct or indirect impact on other necessary investments in a public interest. Therefore, the argument sometimes used to excuse insufficient documentation and revision for credibility: "to save effort and time" supports, in the author's view, more the fact: "to risk to waste money" where it could have been avoided.

The requirement of our MEF (6), allowance of verification and validation, implicitly extends to documentation and proof of credibility. Combat model builders are therefore obliged not only to claim what their model can yield, but to explicitly and scientifically prove this to the model user (see also [70] Summary of Invited Papers p 17). Again, our MEF requirements (1)-(6) offer the set of conditions that help to determine whether or not a combat model abstracts real combat dynamics with adequate scientific techniques.

### III. SPECIFIC MODELLING CONSIDERATIONS

The primary intention of this paper is not to build a manual for a complex combat model for a NATO scenario satisfying the established MEF. One purpose, however, is to analyze shortcomings of current applied modelling techniques and to provide guidance with basic and new ideas that improve on the scientific approach to model some specific aspects required for combined arms actions. We will in the following discussions, particularly, concentrate on various features that are imposed by the MEF requirements with respect to LATMW for a complex theater scenario. Modelling techniques are derived in detail that allow us to extend and to adjust relative simple differential combat models to powerful tools for military cost/effectiveness analysis. Thus, we study now the simplest differential combat model that can be enriched with further detail for any sophisticated precision with the desired level of resolution.

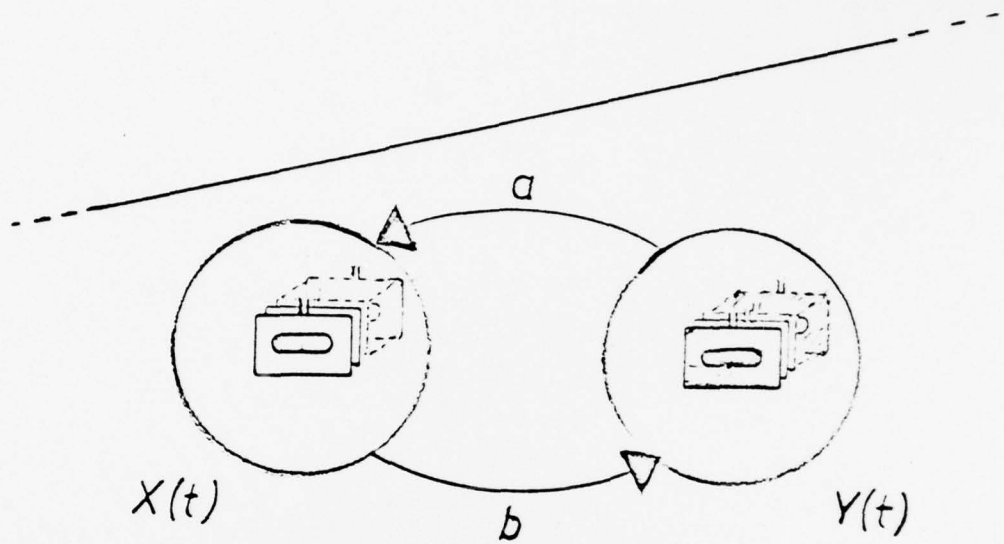

COMBAT ZONE

---

$$\frac{dx}{dt} = - a \cdot y$$

$$\frac{dy}{dt} = - b \cdot x$$

Figure 3 - THE SQUARE LAW FORMULATION OF LANCHESTER

#### A. LATMW AND THE MEF

Our claim that the MEF is an instructive management and analysis tool to check whether a modelling approach satisfies lower bounds to abstract combined arms engagements or not will be examined by considering heuristically Lanchester's original work. Without loss of generality this type of procedure is also valid, if more detailed LATMW or other modelling techniques (Wargaming, Simulation) are inspected with this regard.

The familiar square law (aimed fire) and linear law (area fire) processes associated with the name F.W.Lanchester [28] cover concisely with their assumptions the concept of operations, organization of combat, and coordinating instructions for opposing forces (compare formulations and schematical graphical representation in Fig 3 and also detailed model assumptions in [47]). Essentially a very high abstraction of the information content of STANAG's 2014 Execution is subsumed in these mathematical formulations.

Initial conditions of force levels (number of combattants at the beginning of a battle) describe STANAG's 2014 Situation at the start. Assuming complete information about the contestant's intentions at any time covers STANAG's 2014 Command and Signal. Lanchester attrition-rate coefficients (LARC which are defined to be the rate at which a single weapon system destroys enemy targets per unit time) measure performance of individual weapon systems employed according to STANAG's 2014 Mission. They drive the rate of change of individual force levels at each time step. Except for STANAG's 2014 Logistics and Administration, these

differential equations are first-cut mathematical formulations of the engagement of two opposing homogeneous forces without allowing for any detailed and sophisticated analysis. Whatever academic or philosophical argument may lead to rejection of analytical models, it cannot be denied that Lanchester's original work is a point of departure for building more complex and (hopefully) realistic combat models.

To exercise LATMW with the aid of a computer is relatively cheap with respect to costs for computer running time, even, if these models represent large scale combat in a very detail (see [20]). The mathematical formulation of combat processes with a system of differential equations is highly transparent as opposed to other analytical modelling approaches. The later are sometimes forced to introduce shortcomings in their formulations that lead to pitfalls to a larger extent than one usually presumes.

Differential models play an important and widely accepted role in Fire Support Analysis (see e.g. [70] Appendix 4 and [71]). Recent developments in LATMW consider different effectiveness criteria for extended linear and square law equations that allow to analyze more model detail. They investigate state equations, force ratios, exchange ratios (see e.g. [18], [19] and [29]) or functional criteria (see e.g. [48] and [49]) as performance effectiveness relations. Less is done to resolve consistent logistical aspects for even these simplest of models.

In order to model modern combined arms actions with LATMW other than only two homogeneous opposing forces, even in a combat sector model are necessary. Simple models have to be extended by heterogeneous force formulations, i.e. they have to account for all units and branches that fight battles with modern strategies and tactics. As a result,

some additional relationships to account for more combat elements, the combined arms effort in more detail and precision, their capability, availability and operational dependability (reliability) can fully complete all conditions of (1) and (2) of the MEF using LATMW.

LATMW allow us to focus for an analysis on exchange ratios, state equations or functional criteria. These relationships, extended by cost factors, are then quantities that abstract and relate resource consumptions (inputs) to yielded battle outcomes (outputs). If we weight all inputs with their costs we are then able to analyze by the choice of different battle outcome criteria the economic impact of alternative strategies and tactics, i.e. we obtain cost functions for which either fixed cost alternatives or fixed effectiveness alternatives may be determined. We rectify this hypothesis in deriving later an explicit and new technique that cost effectively relates inputs (economic resources) and outputs (battle outcome predictions) of LATMW to transaction tables for an input-output analysis. This satisfies (3) of the MEF.

Such differential equation combat models must usually be solved with numerical integration methods (see e.g. [95]), since in general analytical solutions are not readily obtainable. Numerical integration methods evaluate the interdependent changes of all time dependent variables of the system of differential equations at very small time steps. Differential equations in general are therefore most apt to represent steadily changing combat characteristics and agree with (4) of the required conditions of the MEF.

The influence of human behaviour and/or decisions may be modeled as a closed-loop decision process or as an open-loop one. The difference of the two model alternatives lies in the possibility to express the impact of behavioral and/or

decision variables corresponding to the choices to model these in combat processes. Closed-loop modules react immediately and correctively through feedback relationships at various critical conditions to the data processing performed in the main model. Open-loop process models interfere with the main model after certain benchmarks are reached that indicate different conditions. Their corrective function, if not omitted, is in effect with a time lag. The various decision processes may be mathematically handled in applying Game theoretic optimization methods to LATMW (see e.g. [50], [51], [60], [61], [62] and [70]). However, it is well-realized that limitations to obtain closed form solutions are imposed by Optimal Control Theory methods. We are therefore urged to refer to the power of Simulations to narrow the disadvantage of these methods in obtaining "best" solutions. Simulations without Game theoretic formulations in only varying some input parameters to explore sensitive effects in model outputs of a first-cut sector combat model satisfy MEF requirements with this regard. In essence (5) of the sufficient conditions of MEF is met with LATMW.

Differential equation models allow us to define all independent variables and/or coefficients. The structure of the system of these equations is relatively transparent with respect to assumptions made. LATMW are therefore also most apt to aggregate in their final formulations various data that are gained from experiments, tests, simulations, military judgement and experience, and from war data. We refer at this point to our chapter Quantifying Model Inputs that will describe a new modelling technique with this regard. Since we show there that all model inputs are verifiable and validiable the author sees in these favouring features with respect to Land Combat Modelling the main advantage in the use of LATMW. We propose to reinforce detailed and extended research work that concentrates on obtaining more qualitative inputs for these models. Hence,

the last and very crucial modelling requirement (6) of the MEF can be satisfied with differential models. A fair amount of characteristics abstracted from complex combat processes can be subsumed in even relative simple differential models. We view the sketched approach as the key to successfully model combat: start from information comprised in STANAG 2014 and follow the MEF requirements at every step in the model building phase. Models that satisfy these specifications and are also free of current shortcomings of combat modelling are fruitful analysis tools. Exercising these models can support the defense management to derive quantitative and qualitative estimates for alternative decisions regarding their operations under their control (in Morse's and Kimball's sense).

Let us summarize with respect to a model design:

Well-studied and detailed sets of differential equations for LATMW are already available (see for an excellent overview [29]). Combat Modelers can use them to build a complex theater level land combat model. These models have only to be feed by inputs that overcome current pitfalls and shortcomings in modelling by considering the following points:

1. Extend capability considerations of combined arms elements (i.e. not only hardware systems) by reliability and availability aspects
2. Include, logistics and economic potential's considerations
3. Formulate more than only one combined arms element (i.e. represent all branches and forces that contribute to the combined arms operation under consideration)
4. Allow for cost effective input-output analysis.

These extensions will yield first-cut models to assist the analysis of current General Purpose Forces problems. The lowest resolution combat models in the hierarchy of the Cone of Abstraction and the MEF (compare figure 2) are achievable and can stand thorough scientific evaluation and analysis. Any consistent extension of them has a conceptual basis towards higher resolutions, typically directed also towards the needs of future research. To illustrate this slightly differently, Micro and Macroeconomic Theory and Application depart from highly aggregated, or low resolution models without pursuing unpermissible suboptimization to derive General Equilibrium Analysis and Optimal Resource Allocations. Instead of using classical models known in Micro and Macroeconomic Theory that don't specifically address combat processes of modern combined arms forces we apply these concepts (general equilibrium analysis and optimal resource allocation) with LATMW that satisfy all MEF requirements. They are therefore tailored to assist an Input-Output Analysis (compare the discussion in the chapter Cost Effective Decisions with LATMW). The special orientation on combat dynamics will provide the military management with scientific decision aids. Although a perfect and complete model does not exist, and will never be achieved, simple and consistent scientific models have always been powerful supporters for the decision finding process at very high levels of responsible decision regarding difficult and complex problems. We again refer to Tsipis' work, as an excellent example, to model the nuclear threat sufficiently at a very low level of resolution.

## B. QUANTIFYING MODEL INPUTS

Rather than leaving the above model design extensions as purely guidelines with respect to model building, we now derive a new scientific approach that allows us to substantiate the above claims. Starting with the exact definition of our systems effectiveness of combat elements represented in LATMW, we then consider an abstraction of state outcomes of components of these systems. We would like to point out that this approach is applicable for a variety of systems (as combat elements) that constitute large scale battles of modern combined arms forces. Finally, we provide the mathematical development to quantify systems effectiveness via observable states of system components and derive our Concept of Estimable Rates.

### 1. Effectiveness of Combat Elements

A combat element is any coherent system that produces a combat activity interdependent in a combined arms effort utilizing hardware, human operators, and decisions, and, thereby uses up scarce resources. This definition arranges combat elements (e.g. in military terms, branches, as armor, infantry, artillery, engineer, supply, maintenance and intelligence, described in STANAG 2014) in a more systematic way for modelling purposes. This will allow us to resolve the systems' structures and then aggregate their capabilities, availabilities, and reliabilities by measurable observations of systems' components. A combat element operates with its maximum effectiveness if and only if all its non redundant components are functioning or

contribute to the overall system effectiveness. We distinguish only between two states, a functioning state and a failed state, and apply this dichotomy to each combat element as well as to each of its components.

The aggregation of combat elements is a coherent system itself and its effectiveness is completely measurable by means of the state identifications of their components. A series or parallel structure of combat elements allows us to apply mathematical theorems which are suitable for coherent systems whose states are specified by binary variables (or Bernoulli or dummy variables) taking on values zero or one, if functioning or failure is observed respectively.

Fig 4 is a schematical representation of this formulation. The choice of the series structure function for combat elements themselves and a series or parallel structure function for interdependent combat elements will be obvious with the following examples.

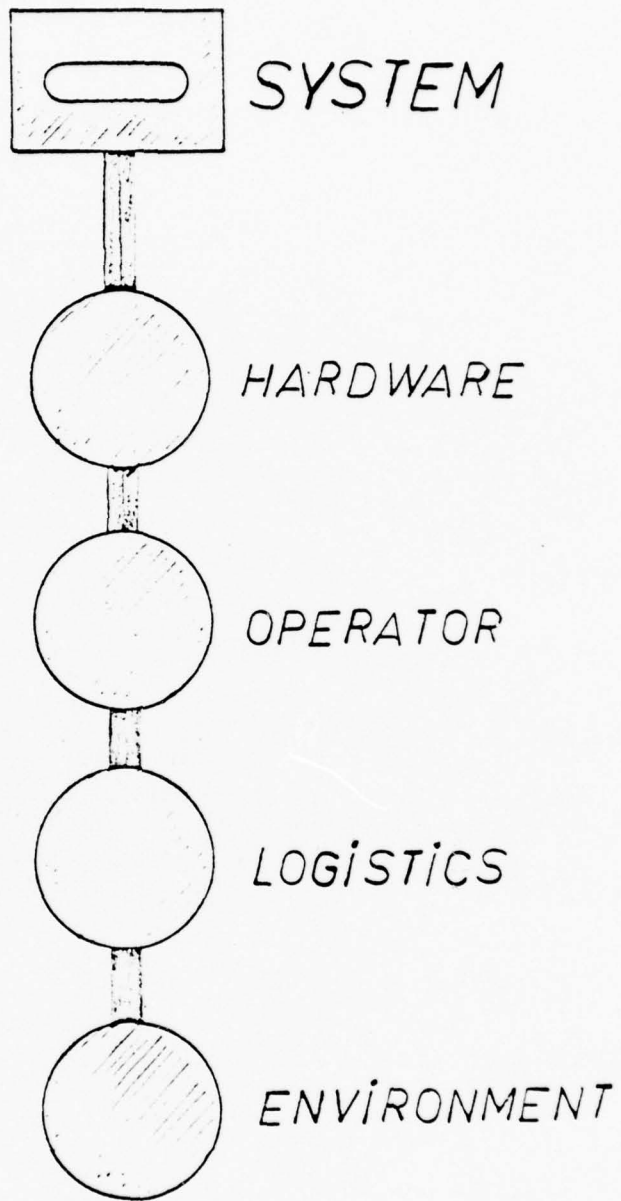

Figure 4 - COMBAT ELEMENTS AS COHERENT SYSTEMS

Suppose two forces are engaged. Any side can only hope to be a victorious candidate if and only if

- the hardware systems are operating, tanks for example
- and the human operators are trained (i.e. know how to handle the hardware system)
- and the operable hardware system is managed
- and coordinated according the order of the battle (i.e. operated in an organizational frame through command and control)
- and the operable and managed and coordinated hardware system can use up and replace supplies.

On the other hand combined arms effort may be characterized with a series or a parallel structure. Sometimes it is necessary to take an objective only with armor, sometimes artillery and engineers are needed to support this branch. We like to get answers out of combat models such as how many combat elements should be employed in series or in parallel and when? These considerations may appear to be trivial, but as a matter of fact they are not and therefore get overlooked in complex combat models (see our discussion of Performance driven Models, which are mainly concerned with the physical functioning of hardware systems). Since our approach to formulate combat in models starts from information presented in STANAG 2014, it should be noted that in our terminology a combat element is a coherent system of components whose states may be either hard or soft information (instances of properties) representations. Under each scenario and mission type the following systems' components have to function in series:

- hardware systems (as a part of our overall complex system)

-human operators, i.e. performance and behaviour (morale suppression, etc.), the human decision interface, i.e. doctrine and tactics, command and control

-resource consumption and allocation, i.e. logistics and economic war potentials

-environmental conditions imposed by scenario and mission, i.e. for example terrain, weather, day or night.

We use the term system or combat element interchangeably but with the above meaning.

The effectiveness of a system is concerned with:

1. The ability of the system to perform satisfactorily when it is called upon to perform (i.e. the system reliability or operational dependability denoted as (R))
2. The ability of the system to begin performing its mission when called upon (i.e. the availability or operational readiness denoted by (A))
3. The actual performance measure of the system in terms of its performance functions and the environment in which it is performed (i.e. the design adequacy, or capability or utilization denoted by (C)).

LARC obtained with current quantification methods (Bonder/Barfoot, Clark) are within these considerations as mostly related to a hardware system's capability to destroy a target. They assume that system components are one hundred percent reliable and available (functioning during the mission time) and are as such only parts to determine our system's effectiveness. The proposed extension to account for more than mere capability of hardware systems (C) must therefore be manifold. We need a numerical index of the extent to which a combat element is ready and capable of

fully performing its assigned mission, i.e. availability (A). We further need a numerical index of the extent to which the performance capability of the system is utilized during a mission, i.e. the reliability (R). Both concepts refer to consistent time dependent functional relationships: availability usually meaning the ability of the system to operate at any given point in time when called upon to do so; reliability for a mission depicting the ability of the system to operate effectively for a specified mission-time-period, usually conditional on its being operable at the start of the period.

The combination of the capability (C), the availability (A) and the reliability (R) as the product of these components yields a combat element's or system's effectiveness (E). This is a measure of the extent to which a system may be expected to achieve a set of specific mission requirements. This quantity is a function of capability, reliability and availability in accordance with the definitions of system's effectiveness in our general modelling consideration and [66]. A simple relationship,  $E = ARC$ , accomplishes an effectiveness measure for LATMW using LARC weighted by the operational demand within a given period when operated under specific conditions. The weighting factors only have to satisfy conditions (1)-(6) of the MEF in being empirical or judgemental time dependent probability estimates of combat elements combining hard and soft information of systems components as regards reliability and availability. This relationship then also includes

- that the systems effectiveness can be measured as the rate at which a single system achieves its mission (e.g. for armor to destroy a target)

- that the systems effectiveness is related to operational performance

- that the system's effectiveness is a function of the environment or conditions under which the system is used. Note that this functional relationship is in accordance with one of the earliest writings with respect to systems effectiveness which still represents one of the clearest and best descriptions of the subject and one from which most subsequent descriptions, such as ours, have been derived [67].

The relationship  $E = ARC$  pertains to reliability and availability estimates for combat elements. Thus, for coherent systems, even very complex ones, we need a mathematical and statistical representation to predict system reliability and availability from either component failure times or component failures whether the components operate continuously or cyclicly. We consider only component failures and denote the occurrence of a failure by one and its functioning by zero. Without violating permissible mathematical operations for measurement scales, the binary variable modelling of component states asks us only to specify which component is considered and to observe its state. Since the dynamic and complex nature of combat processes over any instance in time is to be modeled, we account for spontaneous state changes of components due to mission and combat environment conditions.

After we have explored the detailed structure of a coherent system, decoupled in components, the appropriate structure function can be abstracted (for detailed mathematical treatment see [65], [69] e.g.). We hypothesize from this abstraction that reliability and availability probabilities can be derived via any combat modelling technique chosen (see e.g. [65] p 192-194).

As a more general result for modelling with LATMW denote the possibility that the system is operated in

different operational modes (k) and assume that estimates for

$$E_k = A_k R_k C_k$$

can be obtained and that each operational mode is executed a certain percentage of mission time denoted by  $p_k$ , then

$$E = \sum_K E_k p_k$$

represents the system's effectiveness for different operational modes' dependence. Specifically, with  $\sum_K p_k = 1$ , any desired extension incorporates into system's effectiveness the aspects of reliability and availability of consecutive changing operational modes.

## 2. Hardware Systems, Human Interface, Combat Environment, Logistics Interface

The above proposed modelling extension allows us, even, if a hardware system is not yet produced in lots, to utilize available test data for prototypes. Tolerable reliability and availability lower bounds are specified; why don't we not use them in order to account for more realism in the abstraction process to formulate combat in models to improve on capability quantifications?

For example, consider the combat element the tank. The Bonder/Barfoot or Clark methodology delivers attrition rates for the hardware performance, if the system is assumed 100% reliable and available. Already available empirical life testing data from the institutionalized United States Government Information Data Exchange Program (GIDEP) delivers hardware intrinsic reliability and availability

estimates (see for numerical computing guidance [64], [65], [72], [73] and [74]). The importance of these weighting factors with respect to Life-Cycle-Costs has been fully realized and the need to maximize reliability and availability, or minimize failure rates, found expression in the Reliability Improvement Warranty (RIW) Concept of the US Army (see e.g. [16] p 493).

By utilizing available data, which are obtained by observing and counting the appearance of component states (go-no-go data), we have refined the LARC. It should be noted that a trade-off analysis to answer the question: To buy more less-reliable and available or less more-reliable and available hardware systems can be assessed cost effectively with these extended formulations.

"Rather than aggregate effects, VRI chose to include, and dynamically keep track of, explicit representation of force elements, environment and processes in terms of measurable physical and behavioral variables" [70] Appendix 4 p 32. This statement alludes to the necessity to include more than only hardware performance oriented quantifications in LATMW. However, we quantify combat environment and behavioral variables, for example, with a more appropriate method that yields sound numerical inputs into analytical models. Our component state quantification doesn't force us to measure (How? What are the units and origins for their measurement scales?) behavioral variables. We would probably have to have to aggregate inconsistently different measurement scales and to commit pitfalls. Our behavioral variables, as components, need only be represented as states at different levels and either function or fail. In order to model the human interface, we only ask, for example: Is the necessary command to fire given in time or not? Is the human operator capable enough to convert this command into an action or

not? Is the suppression effect so high that the human operator didn't react as he should have? Is the morale in the unit so depressive that the soldier departs from his expected behaviour? etc. This approach leaves enough room to refine human interface at any degree of high resolution (compare our possible extension in applying the Constant Sum Method).

We consistently specify also environment conditions by binary state outcomes and count the appearance of different component states over a mission. Did fog (to be represented at different levels) reduce visibility? Did sunlight (represented at different levels) diminish the capability to acquire a target? Did snowfall (represented at different levels) reduce trafficability? Did night (represented at different levels) interfere the possibility to give commands with visual aids? etc.

For logistics interface, as our last important component, we give an explicit treatment with respect to modelling implications in the chapter: Modelling Example to gain Estimable Rates. This will explicitly show the general power of the classification of component states. For a brief demonstration now we only indicate that for each logistics' support there are observable states paraphrased with: Has the demand for any support been satisfied in time, or not?

The unique representation of each combat element as a coherent system with at least four independent very highly aggregated components may be viewed in series as a system of:

1. hardware performance
2. human interface
3. logistics interface
4. combat environment.

Any further refinement of its component structure and its associated structure function offer modelling possibilities to any wanted detail of resolution. Structure dependence or redundant subcomponents can be modeled. Once the components' structure function (as aggregated elements themselves) are known (and this will be the most critical part to identify) their state outcomes, either directly observable or easily represented in digital computers for a simulation, deliver the state outcomes one or zero at snapshot instances of a battle. We found a natural way to estimate the interdependent functioning conditions of a complex and coherent system such as our defined combat elements.

### 3. From Binary Numbers to Estimable Rates

Component state outcomes, the failure indicated with one (for convenient estimation of failure rates), the functioning with zero, allows us by the repetitive nature of their observations during an ongoing battle, to count the number of observed states and estimate the fraction of the failure occurrence of states with (q). At this point it will become very obvious why we depart from current modelling techniques and claim that our approach quantifies STANAG 2014 information requirements at the same time meeting all conditions imposed by the MEF.

The idea to express the contribution of states of each component with respect to the system's overall worth is to measure how many times (estimated in % by  $p(i)$  and  $q(i)$ ) for each single component or for a component instance (i), is a prespecified expected demand (the expected overall behaviour of the combat element that model builder should be told) met in time or not? It is required to obtain the percentages for each time step that the modeled component (or instance) takes on values zero (fulfilled demand) or one (failed to match the demand) with  $p(i) + q(i) = 1$ . We can utilize, if further design specifications are implemented, VECTOR-II that claims to keep track of explicit representation of our components or DYN TACS or field experiments of CDEC or military judgement (map exercises, wargames, questionnaires).

We provide now the model that conveniently converts binary numbers into systems effectiveness' degrading rates. Let the total number of specified, independent, and non redundant demands (i) that a component satisfies a

functioning state be  $k$ , then

$$\prod_i (1-q(i))$$

represents the probability of satisfaction of  $k$  components or component levels in time. Assume that  $q(i) \ll 1$ , otherwise  $q(i) \rightarrow 1$  says that components would have failed most of the time and this would lead to mortality of the system. View this also as another complimentary interpretation of the stopping rule requirements for state variables to be  $> 0$  in LATMW formulations in general.

An appropriate approximation yields  $\exp(-r)$ , where  $r = \sum_i q(i)$ . If only one specific demand  $i$  is not satisfied and others are

$$[q(j) \prod_i (1-q(i))] / [1-q(i)]$$

$$\text{with } [1-q(i)] \approx 1,$$

$$\text{since } q(i) \ll 1$$

$$\text{yields } q(j) \exp(-r).$$

Considering that only one demand is not satisfied, i.e. either  $j$ -th or others, extends our derivation to

$$\begin{aligned} & \sum_i [q(i) / (1-q(i))] \prod_i (1-q(i)) \\ &= \sum_i q(i) \exp(-r) \\ &= r \exp(-r). \end{aligned}$$

Applying the idea that each (logical and) of the specific demands is not satisfied, without accounting for ordering establishes

$$[\exp(-r) r^x] / x!,$$

which becomes, by introducing a counting variable  $X = N(t)$  a Poisson distribution with  $(n)$  indicating the observed countings and

$$P(X \leq n) = \sum_x [\exp(-r) r^x] / x!.$$

If a counting variable  $N(t)$  is distributed Poisson with rate (parameter)  $r$ , which is estimable with  $q(i)$ 's through the extent at which each specific demand for a mission is satisfied, then the time  $T$  until  $N(t)$  countings of demand and reaction mismatches have occurred is distributed Exponential with the mean  $1/r$ . We give a heuristic proof of this result, that provides direction for the number of replications for simulation or the sample size for test plans or simulation replications to obtain empirical system reliability and availability estimates (not only in the common performance oriented sense) and their use in LATMW modelling with refinable LARC.

Each mission specific demand  $i$  of a combat element has a distribution  $F(i)$  (only this general property is sufficient, although we can identify these distributions explicitly as Bernoulli distributions with parameters  $p(i)$ , for all  $i$  viewed as independent but necessary variables of the total system). The number of events (identified states) per demand  $i$  counted over a time period constitute, in the long run (mathematically as time  $(t)$  goes to infinity), a stationary Renewal Process. For a battle the counting process is repetitive and stationary for similar combat situations arising over days, which we like to assess with differential models. Knowledge of the Central Limit Theorem of Renewal Theory tells us that superimposed stationary renewal processes constitute a Poisson process (see [64], [92]).

Mathematically we can establish the same result slightly differently, but it is also instructive for a coherent system decoupled into many components. In 1837, Poisson considered the problem of  $n$  Bernoulli trials, but

with the probability varying at each trial (see e.g. [80] p 214). Instead of approximating the Poisson parameter  $r$  with  $np$  ( $n$  = sample size,  $p$  = fraction defective, to stick with the most widely used notation), he approximated  $r$  with  $p(i)$  for all  $n$  different outcomes of  $p(i)$  and showed that both formulations can be approximated by the Poisson distribution (see e.g. explicit treatment in [33], [80] and [86]). Since the same formulation holds in modelling component states, we can easily apply the whole spectrum of methods to obtain Sampling Plans for Attributes Data used in Quality Control for hardware systems, i.e. determine the number of replications for simulations or the sample size for operational tests (see [86]) which find ready application in the military community (see MIL STDs 105 D, 209, 213, 238), if, in fact, the counting variables constitute a stationary Renewal Process and the Central Limit Theorem of Renewal Theory holds.

#### 4. The Final Concept of Estimable Rates

The approach to represent components of combat elements as binary variables and to observe their state outcomes is independent of the length of time for which the above counting procedure for events is applied. In mathematical terms, if the Central Limit Theorem of Renewal Theory doesn't hold and we are forced to assess short time intervals of battle processes (e.g. at each time step the numerical integration results for differential equations of LATMW are updated) then we can still use the basic modelling idea, but with a slightly different Renewal theoretic consideration. Let us establish the final result of our modelling technique that is applicable to consistently quantify any soft and/or hard information extracted from coherent systems. The results will also hold without loss of generality and are independent with respect to the length of

time for which the effectiveness of dynamic systems (similar to those we have defined) is to be assessed.

We define reliability as the ability of a system to perform satisfactorily when it is called upon to perform. Using Reliability Theory's terminology, the failure rate or the hazard function (we use also the term hazard interchangeably) is defined as the rate at which a system dies given it is alive. This is a sufficient and consistent characterization of systems' changing effectiveness over a period of time in a combat environment. Reliability theoretic considerations are subclasses of Renewal theoretic considerations (see [64], [65]) with a change of interpretation of the random variables under consideration. Reliability Theory is mainly concerned with distributional properties of life lengths of systems (failure times, number of failures), Renewal Theory formulates in general terms number of equal events occurring as system attributes (renewal times, number of renewals - our renewals are occurrences of system's components failures). Note that the hazard function uniquely defines the corresponding probability distribution, i.e.

$$f(t) = z(t) \exp\left(-\int_0^t z(s) ds\right)$$

(compare e.g. [74] p 226 - 227), where  $f(t)$  denotes the distribution and  $z(t)$  the hazard. If the reliability  $R(t)$  uniquely defines the expected value of the random process, i.e.

$$E(T) = \int_0^{\infty} R(t) dt \quad (\text{compare also [74]}),$$

and the hazard uniquely determines the reliability, i.e.

$$R(t) = \exp\left(-\int_0^t z(s) ds\right) \quad (\text{see also [74]}),$$

then the relationship between the epochs as the sum of  $(n)$  renewal times  $T$  (denoted as  $(T(n))$ ) and the counting variable  $N$  as the number of  $(n)$  occurrences of renewals in time  $(t)$

(denoted as  $N(t)$ ) holds:

$$(N(t) < n) = (T(n) > t) \text{ (see e. g. [78] p 5).}$$

This relationship allows us to establish our general result:

The last expression above defines the distributional property of the renewal process, i.e. uniquely relates the sum of the renewal times  $T$  [ $T(n)$ ] to the number of occurrences of renewals  $N$  [ $N(t)$ ]. The application of our modelling technique allows us to obtain estimates for these expressions. The quantity of considerable interest in modelling of any renewal process is the renewal function, i.e. the expected value of the number of renewals in time  $(t)$  and is defined as  $M(t) = E[N(t)]$ . Therefore, we can use our estimates (in utilizing any combat modelling technique that is sufficient to represent our defined complex and dynamic combat systems) in order to obtain values for  $M(t)$ . The renewal intensity, denoted by  $m(t)$ , is defined as the derivative of  $M(t)$  for which a last computation yields the final numerical estimates (for our modelling interest) to refine the LARC. In tying Reliability theoretic and Renewal theoretic results together, we observe that the renewal intensity is equivalent to the hazard function (the rate at which a systems dies given it is alive). Using the notation introduced earlier, we can compute our hazards, i.e.  $m(t)=z(t)$  which contribute to the finally wanted reliability and availability weightings. Note, as time  $(t)$  goes to infinity the hazard  $z(t)$  (or  $m(t)$ ) approaches to  $(r)$ , the parameter of a homogeneous Poisson process. (For computational assistance to obtain system hazards with our modelling technique compare the methods described to approximate Renewal functions e.g. in [78] p. 28-37).

The power of this modelling approach is to be seen in the consistency and exactness to aggregate any soft and/or hard information that describe the degrading effects

(failure rates) of dynamic systems. Furthermore, the contribution of all system components with respect to the overall worth (effectiveness) of combat systems can be assessed with one modelling technique. This approach for modelling systems effectiveness departs from state-of-the-art models (e.g. from DYN-TACS or VECTOR-II) in many ways:

First, we don't intend to use less detailed data to describe a complex problem. The differences lie in the method to implement this information in existing formulations of combat models. Reliability and availability considerations provide a theoretically sound and, as we will show explicitly, a handy way, even for large scale theater level models, to extend capability or performance measures of systems and their effectiveness analysis.

Secondly, we aren't forced to use inconsistent data processing modules to degrade state variables "somewhat". Distributions for random number generators to "adjust" battle outcomes in models that utilize random variates by oversimplifying combat abstraction in assuming "uniform or normal distributions" can also be avoided (see a detailed discussion with this regard for DYN-TACS in [91]). Instead, we are able to combine soft and hard information characterizing - hardware systems - human interface - resource consumption and allocation, and -combat environment conditions. Free of committing any pitfalls, we relate this extracted and combined information to the overall system under consideration with an analytical functional relationship.

Third, we are able to explicitly state what conditions of STANAG 2014 information is modeled and which MEF requirements are met.

Fourth, we can utilize any modelling technique (either War Gaming, Simulation, or Analytical Models) and are able to

incorporate as much as possible from results of RDT&E, field experiments and military judgement to verify and validate the results. We give sufficient indications for sample sizes or number of replications. This information can easily be combined with LATMW.

Fifth, we direct to further research needs in order to explore the main elements and components which drive combat outcomes.

Sixth, we are able to assess, cost effectively, economic resources.

Finally, we are able to enrich a low resolution model to any degree of higher resolution without committing inconsistent aggregation.

Let us summarize, in pragmatic modelling design terms, given a detailed binary representation of systems components, we are able to obtain the system hazards for homogeneous or inhomogeneous Poisson processes (see e.g. [87] p 129 - 133) and can therefore uniquely determine the combat elements' reliability and availability. Since the derived methods are applicable to any complex systems operating for any mission time and the key relationship of interest to assess combat more isomorphic is the systems' hazard we name this approach Concept of Estimable Rates.

We would like to point out that because of the possibility to explore the system's hazard or the renewal intensity the availability  $A(t)$  is also easily obtainable (see [78] p 19 - 21 or [65] p 190 - 201) and Availability theoretic results (see [65] for more background information) can be established either for short-time or for long-time considerations.

The Concept of Estimable Rates is therefore an

application of Renewal theoretic considerations whose estimable hazards can be obtained in a consistent scientific way that meets all requirements of the MEP. It allows us to model any wanted detail of soft and/or hard information from STANAG 2014 (Note an alternative theoretical sound approach to reduce this "any wanted detail" to the most driving subcomponents of components of combat element would be by the regression on dummy variables with its not yet resolved limitations of the state-of-the-art).

### C. ESTIMABLE RATES AND REFINED LARC QUANTIFICATIONS

For simplicity, let us now consider some estimable rate formulations in LATMW with constant LARC, even our general result would us not restrict to this at all, i.e. we assume that one has obtained estimates for LARC and for their reliability and availability weightings (homogeneous Poisson processes) that deliver constant refined LARC. The abstraction of each combat element's structure as a coherent system with at least four independent components in series requires at least four hazards for the reliabilities which degrade system capability, the LARC denoted by C. By the choice of a proper mission time or battle stopping rule and the mission hazards, the mission reliability of the system becomes

$$R = \exp[-(z_1 + z_2 + z_3 + z_4)] = R_1 R_2 R_3 R_4.$$

The expected proportion of time the system (or force or combat element) is operating during the mission time (availability, A) is defined by

$$A_{ij} = (1/z_i) / (1/(z_i + z_{jj})),$$

where  $i$  corresponds to the mean functioning time (reciprocal of the hazard) and  $j$  corresponds to the mean repair or recovery time of the system's components  $1, \dots, 4$ . The total degrading of the LARC estimates due to hardware's, human interface's, logistics' and environment's reliabilities and availabilities is aggregated in

$$E = R_1 A_{11} R_2 A_{22} R_3 A_{33} R_4 A_{44} C.$$

The solely performance oriented LARC,  $C$ , can be refined by means of observations, simulations and experimentation in a scientific thorough way.

It should be noted that the mean repair or recovery time of a system's component usually is not deducible from homogeneous or inhomogeneous Poisson processes. Hardware systems' repair times are most likely to follow lognormal distributions and nomographs exist which allow us to convert distribution parameters into the corresponding arithmetic means, which are used in the  $A_{ij}$  (see for explicit treatment [89]). Even, if the hazards follow Poisson processes and the repair or recovery times are generally distributed, bounds on the availability function are obtainable, which can serve as appropriate approximations, not solely based on unvalidated judgements or inconsistencies which might be committed in modelling complex systems (see for a general treatment [88]).

For each reliability - availability pair of a single component some extended formulations are helpful for modelling purposes.

Define as mission reliability ( $R_m$ ) the probability that the system will operate without failure for the mission time

$(t_1)$ .

Define the operational maintainability of the system ( $M_o$ ) as the probability that, when a failure occurs, it will be repaired in a time not exceeding the allowable downtime ( $t_2$ ), then the effectiveness (E) is

$E = C A D$ , where

$$D = (R_m + (1-R_m) M_o)$$

Define the fraction of mission time that a system's component can be down without detection as ( $p_{dwd}$ ), then the availability can be refined by

$$A = p_{dwd} R + (1-p_{dwd}) A_{ij}$$

These formulations already refine LARC to such an extent that critical combat situations can be successfully modeled. The impact of wrong tactical decisions can be expressed by the mismatch of the observed state from desired state (in our modelling technique the binary number 1). For the component "human behaviour" we wish to get estimates of how long the allowable "down time", i.e. the time to correct the wrong decision, should be, in order to repair this failure. In the second modelling refinement we have for this problem a possibility to estimate the fraction of time we could operate without detecting this failure and at the same time not being completely maneuvered in a disadvantage, because component failures weaken system's capabilities.

Finally, estimable rates are extendible to any degree of resolution, since the hazards used in the reliability and

availability formulations can be gained by convolution of random processes, and in the Poisson case the reproductive property of a Poisson process yields a Poisson process [74] p 218-219. Therefore, with very simplified formulations of LATMW, such as with refined constant LARC, we gain insight into the impact of components with respect to their effectiveness in complex battles. Model building is now not primarily a question of how to incorporate these problems, but only a matter of how to efficiently manage huge amounts of information at different levels. Given the system's component structure function we found a conceptual design to adjust existing models to MEF requirements without committing common pitfalls, especially, Performance Orientation and Measurement Scale Mixes.

D. MODELLING EXAMPLE TO GAIN ESTIMABLE RATES

1. Objective and Worth of Logistics

Logistics' nature is to provide supply and maintenance of man and materiel over the length of a ground war by steadily executing the functions

1. assembling
2. stockpiling
3. allocating to prior demand
4. transporting
5. distributing
6. maintaining
7. repairing

in order to meet support requirements generated by the troops on the battle-field. These inherent components of logistics have to operate in series and demand specific manpower strengths, organizational forms and management skills, hardware capabilities and resources to be operable in changing environments over the course of a battle. Thus, logistics' objective can be defined as the optimal managing of man and equipment to match supply and demand timed according to missions of Ground Combat Forces throughout the Combat Zone.

## 2. Performance Description of Supply in Materiel Classes and Categories

Supply goods are divided accordingly into two categories, both covering all their variety in amount and tonnage.

Materiel classes:

-goods used up in large amounts:

AMMO, POL, food, water

-interchangeable goods (defect for working)

-goods used up in small amounts,

spare parts, new system's parts

and new systems

(i.e. stockpiling and transportation criterion

for supply units)

Materiel categories:

This is a categorization of materiel according to amount and importance with which it is used by specific weapon systems or combat elements (e.g. infantry, armored infantry, armor, artillery, engineer) for their military missions. It indicates primarily for managers allowance and priority of the demands of materiel.

In essence, thousands of different goods that supply units deal with are manageable by characteristics that are aids for ordering and identifying. Supply units transport materiel from superior supply units on predetermined routes

(no interference with other strategic or tactical movements) to their storage location (abstraction by pipeline systems or networks). Supply units react according to priority rules given by superior command at each individual demand and signal to the customer the earliest time of availability of this demand. Supply elements at each command level distribute them thereafter to the final user or consumer. Supply goods can be demanded, if supply levels reach a certain benchmark or a priority is announced by a command.

### 3. Performance Description of Maintenance

Highly technical weapon systems which tremendously increase life-cycle-costs (see for definition [35], [36]) are worth being saved if damage occurred for which repair is very promising. Therefore, maintenance units concentrate on, in addition to repair failures caused by aging or usage, systems damaged by enemy activities. Maintenance facilities have to be placed according to prespecified priority rules at locations where no interference with other combat activities is expected. These descriptions of the main functions of logistics allow quantitative measures of performance at each level of command.

### 4. Performance Quantification

Commonly used performance measures for logistics are:

- number of goods stored per materiel class and category
- number of tons transported per materiel class and category per km
- number of items delivered with and without delay per

materiel class and category, both specified in time intervals

-number of alternative items delivered, if shortage occurred, per materiel class and category

-number of weapon systems saved per combat element and/or time

-number of repairs or repair time intervals for failures caused by aging or usage, per combat element

-number of damaged weapon systems saved during a combat action

-number of enemy damages repaired per weapon system and time

-number of logistics activities degraded by enemy activities, mainly interdiction.

Only some MOPs of logistics (supply and maintenance) have been listed and they indicate the kind of performance descriptions widely used in combat models, as well as in the military community. However, the unresolved question is, what conclusions do these lists of numbers allow us to draw with respect to logistics effectiveness and their impact to combat elements? Are tons transported and number of weapon systems repaired sufficient quantifications to formulate directly that a tank can fight better than his target? The answer is no. These are only necessary quantifications. Two more logical steps are needed to assess logistics' impact:

-consistent conversion of MOPs to quantities expressing logistics' overall system effectiveness (MOEs)

-relation of logistics' MOEs to system performance and then to derive total system effectiveness, for example for a tank.

## 5. Effectiveness and its Relation to Systems

Given these performance measures, we are looking for numeric expressions that indicate how logistics, as a complex single component, is able to match supply and demand. More specifically, we need quantifications of the states of the logistics components for each time step of a battle that measure logistics effectiveness and subsume:

- deliver each individual supply item that has been demanded by a military consumer in time
- save each damaged weapon system that can be repaired in time
- repair and overhaul damaged weapon systems in time
  - before the start of a new mission
  - for continuing military operations
  - during recovery in a pause of action.

The degree of accomplishment of these tasks thereby indicating the degrading or nondegrading effects of logistics with respect to a combat element's effectiveness imbedded in strategic and tactical missions and scenarios.

The representation of the flow of materiel (i.e. the connection of all components that belong to a logistics system) are easily handled with networks in a digital computer routine. Optimization algorithms for the resource allocations exist too (see [83]). Reactions of logistical performance to needs generated by combat elements can be simulated and logistics' effect in combat is consistent represented. More critical and important is the problem of how to use the information generated most aptly and consistently by these powerfull means.

DYNTACS, for example distinguishes between non-destructive, firepower, mobility, and total kills of weapon systems. Are these not natural demand generators for logistics maintenance services? Damage assessment models exist which are then able to deliver very detailed data (see [90],[16] Volume 1 p 401). VECTOR - II keeps track of combat elements' locations on a digitized map for a theater level battle and trafficability parameters and movement characteristics can generate, with corresponding rates of weapon system's advance, POL requirements. The expected number of AMMO rounds, needed to kill a target extracted from LARC computations deliver the AMMO consumption data by type and weapon system.

Instead of only computing totals of tons required, the number of different supply items needed and the amount of maintenance services asked for, and comparing those relatively with the equivalent total amounts that could be served, we dissolve this aggregation and count the number of individual mismatches of requested demands and executed supplies, categorized for single combat elements and ordered by critical mission times. In addition to the flow of services through the logistics network, this state representation provides a natural way to estimate the fraction (i.e.  $q(i)$ 's) of logistics' component failures within a time frame. The corresponding hazards are computable as time dependent functions. The reproductive property of homogeneous Poisson Processes and convolutions of inhomogeneous ones establish a logistics' overall hazard, if different level of resolutions (i.e. commands) are aggregated. Reliability and availability probabilities which degrade the combat element's capability, the LARC, are computable in a consistent and scientifically thorough way.

Combat is dynamic and spontaneous. Therefore, all

time dependent changes of system effectiveness caused by system's component failures can only be modeled with time dependent parameters. We need formulations of system effectiveness in LATMW that are immediately sensitive to these changing conditions over time and not highly aggregated tactical decision rules. The later are most likely to be implemented in models at an inconsistent level of resolution and, moreover, in a time lag. Since logistics components operate continuously it is indispensable for a differential model, such as VECTOR-II, to ask, at the same time as other possible input parameter for example, target acquisition times, times of flight of a projectile dependent on range etc. are updated to adjust LARC accordingly to all changing combat environment conditions. In our particular modelling example we have to ask how reliable and available are logistics components to accomplish their mission.

The Concept of Estimable Rates offers a unique and consistent way to estimate systems' components reliabilities and availabilities. Adjustment of existing models to this modelling technique, and their extension by similar quantifications of human interface and environment conditions, guarantee refinement of the assessment of combat dynamics via differential models, simulations, and wargames.

## E. LOGISTICS AND LIMITED RESOURCES

We found in reviewing existing land combat models that formulations of logistics problems don't satisfactorily address the evaluation of logistics's worth and objective. One assumption often made in logistics considerations is: "resources are assumed to be available in unlimited amounts". Marshal Sokolovskii's argument, based on Lenin and Engels: "Military power is derived from a nation's economic status" [52], is simultaneously disregarded, as is the fact that each cost effective analysis has to trade-off between scarce or limited resources.

In LATMW, we have to consider possible replacements of combat elements' resources. The consumption of combat elements' assets is mostly formulated with replacement rates (rate at which a demanded supply [ "of any kind" ] must be replaced per unit time). This may be a first-cut indication of how many different and/or equal goods must be stored. The more decisive question however, is, are production capabilities of an industry in the position to produce and deliver these requests in time. For simplicity, and to avoid model complications (but not infeasible ones) it is assumed that "resources are unlimited", in other words fighting forces can always get their predicted consumption replacements. How important it is to analyze, whether requested supplies are available or not (and not only to express the amounts in which they would be needed) has again become apparent in a recent conventional conflict, namely in the ARAB - ISRAELI War (1973). Israeli armored units couldn't fight and expand some of their advantages in the first days of the war because they have been out of AMMO and

POL. Only the use of classified references would allow us to pursue this problem to the very detail. We can stress our point in this context without doing this and observe that the "unlimited resources" assumption in a theater level scenario model never does address real logistical consideration. The coordinating of production and consumption, the possible distribution and the delivery in time are the main logistical aspects that should be modeled with regard logistics and supply. We like to get answers like, why, and how "logistics influences all battles and decides most of them" (to quote General Eisenhower's statement again). Urgently needed improvements of this subject in combat modelling have also been expressed, for example, in [53] and [54].

Simple LATMW with time dependent replacement rates formulations (see e.g. [18] p 527) extended by reliability and availability weightings (estimable with our Concept of Estimable Rates) can easily be utilized for the analysis of logistics and economic impacts of battles. For our coherent system, to model this, production plants are components, transportation networks are components, supply dumps are components, etc.. Their functioning or failure determines the percentage values that degrade the amount of predicted replacement rates. Such quantifications are more suitable to model logistical aspects. In order to assess their economic impact we have to cost out our coherent system that models this phenomena. Hoffenberg's and Leontief's work of the early Sixties: "The Economic Effects of Disarmament" [93] provides (seen from the analysis method applied) with a different interpretation (what Economic Effects does Armament have) an analysis tool (see our discussion Input-Output Analysis) that could help to answer these important questions. In asking for more detailed modelling of logistics' worth and objective one has also to include in LATMW Air War Strategies that enhance or weaken ground

combat forces activities. If an opponent concentrates on massive interdiction, Ground Combat efforts can be paralyzed in only causing heavy damages to logistics systems or industrial plants.

#### F. HETEROGENEOUS FORCES AND SUPPORTING WEAPON SYSTEMS

Heterogeneous force formulations are successfully implemented in models, as [44], [58], [59], [63] and [93] for example. This refined modelling approach asks for far more inputs (LARC) as homogeneous force formulations do. Without going into too much detail of this powerful modelling technique (allows to formulate less aggregated coherent systems as combat elements) of combined arms forces, we have to direct a warning to avoid pitfalls and shortcomings (see Measurement-Scale Problems) that might occur in the attempt to obtain "pretty refined" LARC estimates (e.g. to express suppression) as inputs for these models. Heterogeneous forces are not only combat units equipped with different capable weapon systems, but also combat units composed of various components of branches. Heterogeneous forces already occur, if a tactical or strategic commander transfers his focal point from one combat unit to another by changing the general branch composition of a brigade, division, or corps. We are fully aware of the complexity of problems that may arise by the trend to model each possible battle order. For first-cut LATMW, this complexity problem may roughly be resolved with the tendency: "less and good is more valuable than much and worse". In considering only homogeneous forces of one type for combat assessment, as a start to gain insight into combat dynamics, one should, however, at least consider also homogeneous air forces. Their impact with respect to logistical considerations and FEBA movement (Forward Edge of

the Battle Area) for example, are essential in any General Purpose Forces combat outcome. Some simple LATMW formulations allow to determine optimal strategies for air allocation (see [60], [61], [62]). For more complex differential equation models analytical solutions that determine the optimal strategies are mathematically intractable. Simulations that replace an optimal solution algorithm by varying input parameters and observing the corresponding battle outcomes may then serve as a welcome surrogate, especially, since LATMW for theater level sector models are very cheap with respect to computer running time.

#### G. COST EFFECTIVE DECISIONS WITH LATMW

Let us remind the reader that one reason to build combat models is that the Defense Management looks for assistance in deriving cost alternative decisions for Ground Combat Forces problems. Therefore, we have to include in Modelling Considerations for LATMW some aspects that show how we are able to direct with these models and in using our refined LARC formulations (with reliability and availability weightings) to analyze the impact of land war objectives with respect to economic potentials. We discuss now how Input-Output models can be applied to military problems in general. Next, we concentrate on obtaining lower bounds for Force Postures and Commodity Levels. Finally, we derive quantifications (obtainable with our refined LARC) for these and for the Net-output vector elements (the measures of effectiveness [MOEs] for the destructive capability of the overall system, for example an armored division) as model inputs weighted by their costs.

## 1. Input - Output Analysis

Leontief's Input-Output model [5] has been extended to the Program Planning Budgeting System (PPBS), under the LAIRD/PACKARD FISCAL CONSTRAINTS [6] in order to help the resource analysis community meet the challenges posed by the tight defense budgets of the future in examining the analytical resources which are available to us today. Familiarity with this linear model reveals (for detailed information see [5], [6]) that the difficulty for a low and high resolution consistent costing approach in Defense Planning for General Purpose Forces lies not in the complexity and infeasibility of obtaining meaningful numerical solutions. The problem is how to adequately quantify Commodities produced by Services, or Mission Direct and Support Categories. How are for example, Program Elements of the Five Year Defense Planning (FYDP) programs quantified with effectiveness descriptors? Using the terminology introduced in [6], Force Postures quantify the output of Force Program Elements and Commodity Levels measure the output of the Support Program Elements. Now, admittedly, it is not always easy to identify and numerically abstract Force Postures and Commodity Levels (see [6] p 376). The worth of the analysis is highly determined by the choice of MOEs of Services or their Program Elements.

The resource analysis and the combat modelling community are confronted with the same problem. In context with our MEF (2), abstraction and numerical representation of MOPs and their relation to MOEs, both groups try to address these questions, the first is more concerned with cost aspects, the later with strategies and tactics. The

MEF guides to derive consistent and sufficient abstractions of combined arms effort. LATMW, oriented on this, may then serve as producers of Service oriented MOEs. We have shown (in our Modelling Example to Gain Estimable Rates) that for logistical assessments tons transported in km, number of items stockpiled and distributed, number of weapon and/or hardware systems repaired are no proper choices, to be weighted with costs, as inputs for transaction tables. These are no adequate measures of effectiveness of a branch, since they don't express the overall system's worth and objective. However, in military costing procedures almost every so-called effectiveness quantification has only the character to be a measure of performance. Representative examples are: intelligence activities in thousands of man-hours, command and control activities in man-hours, ship steaming-hours in thousands, each per year and associated with their costs.

An input-output model combines the total resource budget, or the appropriation vector ( $W$ ) with the indirect and direct resource requirements. The direct input matrix ( $R$ ) and the net-output vector ( $Y$ ) are related to the costs ( $W$ ) by the following quantity  $W = R Y$ . Addition of the elements of the vectors, the left and right hand side, connects the total budget spent to the net-output elements weighted by the sum of their primary input matrix elements (which have also the dimension: costs).

Consider only  $Y_1$  as the ARMY net-output,  $Y_2$  as the NAVY net-output,  $Y_3$  as the AIR FORCE net-output. The change of total dollars spent per unit net-output can be obtained by taking the partial derivatives with respect to the net-output vector elements. The total differential of the above expression yields the marginal rates of technical substitution (see for further detail [3], [4]), because the

AD-A038 621

NAVAL POSTGRADUATE SCHOOL MONTEREY CALIF  
DESIGN CONSIDERATIONS FOR LANCHESTER-TYPE MODELS OF WARFARE (LA--ETC(U)  
SEP 76 H MAUERER

F/G 15/7  
(LA--ETC(U)

UNCLASSIFIED

NL

2 of 2  
ADA038621



END

DATE  
FILMED  
5-77

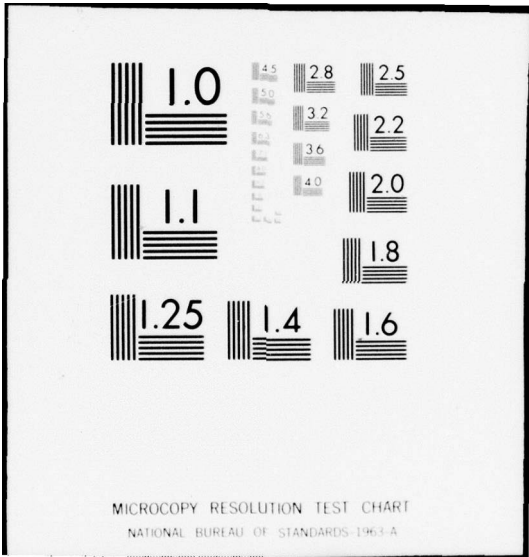

initial set-up of the input-output table constitutes an arrangement of production functions whose factors are in terms of currency values and the relationship  $W = R Y$  converts these into cost functions. It should be noted that "costs" in these formulations are merely currency expenditures of a budget and not costs defined in Micro/Macroeconomic Theory (e.g. life-cycle-costs).

Since the resource analysis and the combat modelling community are both challenged to assist in the cost effective mastering of General Purpose Forces problems, we propose to use the effectiveness quantifications of LATMW as well as in the Input-Output models. Their common level of resolution is guaranteed and with respect to a desired analysis one common basis is established. We are able to assess systems effectiveness criteria that drive battle outcomes in LATMW and the resource allocations that went into these quantifications.

Conceptually this methodology offers a consistent and sufficient linkage between Force Postures converted into direct costs and Commodity Levels (as support costs) and the net-output vector (i.e. the destructive capabilities of our systems or combat elements). We are able to do this because the application of our MEF requirements for combat models directs us in an unambiguous and reproducible manner to overcome the design inadequacies of many combat models with this regard. Essentially Tsipis' work to analyse the nuclear threat found a directive for a low resolution partner to consistently assess General-Purpose Forces role connected to the economic impact.

## 2. Lower Bounds for Force Postures and Commodity Levels

We stated earlier that the work of Taylor and Parry has tremendously enriched cost effectiveness considerations using simple models of LATMW. The importance of this remark will now become obvious.

Consider the formulation of a combat element as a complex system that is only functioning if and only if all components are functioning. What performance characteristic, for example for armor, as a complex system, allows us at least to fulfill specified missions? Refined constant LARC with reliability and availability weightings may serve as indicators for this. We restate briefly their basic results, applicable also for time dependent LARC (see for detail [19])

-local conditions for force superiority may be based on comparing the force ratio with the instantaneous force-change ratio (both expressed as friendly to enemy with two force level variables)

-a side is winning "instantaneously" when the force ratio exceeds the differential casualty-exchange ratio if no replacements and withdrawals are introduced

-supporting fires not subject to attrition are equally effective; i.e. they cancel out, so that the battle's outcome, although accelerated, is the same as though they were not present (for combat between two homogeneous forces).

Realizing that only refined LARC's and state variables (force levels) are involved, enables us to obtain

lower bounds on LARC and state variables which always ensure definite predictions of battle outcomes. If we use the same lower bounds on refined LARC and state variables and extract from these costed effectiveness criteria lower bounds for inputs in transaction tables then we obtain for a scenario that utilizes these bounds in a model:

-sufficient lower bound conditions for LARC and force levels in order to be winning or to maintain deterrence with Ground Combat Forces

-sufficient lower bound conditions for costs, i.e. what amount of the Gross-National Product (GNP) do we at least have to sacrifice in a yearly budget for military commitments given by the corresponding scenario.

Further detailed analysis of the effectiveness of combat element's components is feasible. For example, assume lower bounds for constant, but refined LARC could be found which establish lower bounds for weapon system's components capabilities, reliabilities and availabilities. Many combinations for this fixed effectiveness offer a variety of cost alternatives and the efficient and cheapest combination can be identified that powers up to the required overall effectiveness of a combat element. On the other hand, for an input-output analysis, measures as tank driving-hours, intelligence activities in hours, tons transported in hours, can be substituted by measures with respect to system's worth in using MOEs based on LATMW and refined LARC. We gain insight into the order of force levels, their individual system's components' effectiveness and their corresponding costs. Simple, but non-trivial, results derived from LATMW and very aggregated transaction tables for an input-output analysis, consistently joined, assist in solving complex military problems that are mainly concerned with the consumption of scarce economic resources.

### 3. Inputs for Transaction Tables

We began our development of a MEF for combat models with a critical analysis of currently committed pitfalls and shortcomings in constructing these models. One major shortcoming was the inadequate substantiation for cost considerations. Huge amounts of numbers get cranked in the yearly Planning, Programming and Budgeting procedure for the Defense Budget. Political decision makers are sometimes hard to convince why exactly (x) dollar amounts are required by the military community to fulfil their missions. We see a very important improvement, with this regard, in the ease of application of LATMW models as low resolution decision-finding aids. They are very transparent and the sensitivity of Force Posture and Commodity Level changes with respect to the net-output vector due to limited or reduced appropriations can be systematically shown. We propose to change the input quantification of Commodity Levels of the net-output vector in a transaction table. At the same time, we demonstrate that a valuable combat model, such as a differential model, is no freestanding model that could be produced whenever it is requested. Combat models are complex and interdependent data processors that only deliver reasonable results, if consistent information that further detailed and extended research work on a variety of models can produce is combined.

In deriving the Concept of Estimable Rates, we proved that the hazard of a system can be considered as constituting a Poisson Process. We know then, for example the rate at which a hardware system's failure occurs, and we also are able to identify, by means of a damage assessment model, the kind of failure. The underlying procedure to

model the component logistics of our system is for example: First, generate demand for logistical needs; secondly, determine the estimated time to repair failures (for supply and maintenance); third, use the same assessment routine to estimate the time that a combat element or system's component has to stay in the damaged or down state.

One basic aspect of every planning model is the planning horizon. Thus, to maximize the utilization of the time systems are effective within a time frame, or to minimize the expected time a system is idle (in input-output analysis terms the Commodity Levels and Force Postures) is a consistent effectiveness quantification of Program Elements. Both failures and down times of system's components follow independent random processes, failures a Poisson process and down times, for example, may be lognormal distributions. The overall stochastic process can in general be formulated as a compound Poisson process (see for further detail [87] p 132-133). If the Poisson process is inhomogeneous, then the stochastic process can be sufficiently described, for our interest, as the expectation of a random number of random variables (see also [87] p 73-74).

Denote the random number of failures by  $(N)$  and the random variable down time by  $(T)$ , then  $E[N] E[T]$  is the expected down time as a measure of system's components idle state. Subtract from the planned time horizon (for a yearly budget, e.g.) the expected down time. The resulting net-operating time, denoted by  $OT$ , is a consistent Force Posture or Commodity Level effectiveness quantification for the transaction tableau. It should be noted that we need a damage assessment model, for example [90], a high resolution model, such as DYN TACS to generate the damage, a differential model, such as VECTOR - II which would allow us by proper adjustment, to estimate desired Estimable Rates (at different levels of resolution), and an input-output

model, for example the Electric Five Years Defense Plan System [6] to consistently analyze Program Elements' effectiveness quantifications. The subtraction of down times from planning horizons is also an improved MOE specification for all other components of our system to be analyzed in detail with respect to their economic impact. In effect, all Force Posture and Commodity Levels have one common effectiveness criterion combined with their costs, namely the consumed dollar amounts to produce net-operational times.

The effectiveness (E) of our systems has been defined by the relationship  $E = ARC$  [availability (A), reliability (R) and capability (C)]. These refined LARC, with specified lower bounds, can have higher values by reinforcement of system's elements performance characteristics, change in doctrine and tactics or more effective evaluation of intelligence etc.. There is no need to analyze each of possible alternatives separately in a complex transaction tableau with respect to the net-output vector. We aggregate their different effects into one single numerical measure. Arrange the different availability probabilities as a vector (A) with elements  $a_i$ , the reliability probabilities as a matrix (R) with entries  $r_{ij}$  and the performance based LARC as a vector (C) with different values  $c_i$  that may be obtained by incorporating their range dependence, then the overall system's effectiveness (E), in accordance with [68], is aggregated in

$$E = \sum_i \sum_j a_i r_{ij} c_i$$

This formulation seems to be a more appropriate Net-Output vector quantification than the commonly used MOEs for the most crucial inputs in an input-output matrix.

Let us finally relate our results to transaction table inputs that can be gained by the application of our modelling improvements for LATMW. Suppose we consider the Commodity Levels Logistics (CLL) and the Force Postures Infantry (FPI), Light Armored Infantry (FPLAI) and Armor (FPA). Suppose also that for each of these commodities the appropriations are categorized in personnel (PERS), procurement (PRO) and operational (OP) costs whose entries in a matrix are denoted as appropriation costs  $AP_{ij}$ . A cost accounting system (oriented on the structure of our coherent systems of combat elements) supplies the total amounts of dollars spent for the above commodities. Denote their corresponding entries in a matrix  $CC_{ij}$ . Based on reliability and availability estimates (from our component hazards) and from capability quantifications with unrefined LARC compute the Net-Operational times ( $OT_{ij}$ ) as Commodity effectiveness measures. The Net-output vector elements as effectiveness measures for FPI, FPLAI and FPA are the refined LARC ( $E_i, i=1, \dots, 3$ ) respectively from our derivation of the quantities  $E_i = A C R_i$ .

Introducing the same notation for transaction table submatrices S, U, D and V as in [6] we relate their elements to the following above defined quantities with their corresponding physical meanings:

$$S_{ij} = CC_{ij}/OT_{ij}$$

= Dollars spent/Net-Operational time per Support Element

$$U_{ij} = AP_{ij}/OT_{ij}$$

= Dollars appropriated/Net-Operational time per Support Element

$$D_{ij} = [CC_{ij}/OT_{ij}]/E_i$$

= Dollars spent by friendly firers per destroyed target

$$V_{ij} = AP_{ij}/E_i$$

= Dollars appropriated per refined LARC.

$\frac{\text{DOLLARS SPENT}}{\text{NET-OP. TIME}}$	$\frac{\text{DOLLARS SPENT}}{\text{DESTR. TARGET}}$
$S_{ij}$	$D_{ij}$
$\frac{\text{APPROPRIATION}}{\text{NET-OP. TIME}}$	$\frac{\text{APPROPRIATION}}{\text{LARC}}$
$U_{ij}$	$V_{ij}$

Figure 5 - MOE FOR AN INPUT-OUTPUT TABLE

Fig 5 shows the matrices S, D, U and V in the general context with our newly defined elements. With these notations the primary input matrix R is then

$$R = [U (I-S)^{-1} D + V],$$

where I is the identity matrix.

Since the appropriation vector W is  $W = R Y$  we identify the term  $[U (I-S)^{-1} D Y]$  as indirect costs and the product  $V Y$  as direct costs with respect to the Net-output vector Y. The elements of the appropriation vector W represent the total appropriated dollar amounts for Commodity Postures and Force Levels. This combination of effectiveness quantification based on our refined LARC formulations and the input-output table allows us to utilize the same MOEs (the hazards related to operational time and the refined LARC) that provide guidance for strategies and tactics exercising LATMW and in analyzing battle predictions such as casualty-exchange ratios, force ratios and functional criterion (e.g. FEBA-movement distance). As a consequent extension of this connection of models (the LATMW and the input-output table) we are able to gather information about the economic impact of changes of battle predictions in terms of dollar amounts of the GNP. Our General and Specific Modelling Considerations ask us to adjust Combat and Input-Output Models oriented on a MEF and on refinements of formulations in LATMW. The scientific assessment of General-Purpose-Forces role primarily depends on the quality and availability of reproducible inputs for these models. Therefore, extended and detailed research work must be devoted to obtain sound estimates for these quantities.

## H. A FIRST-CUT SECTOR LATMW

In order to complete our Design Considerations for LATMW we give now the formulation of a Sector Combat Model that is only one example for many possible abstractions of different combat sector scenarios.

### 1. Model Assumptions

Let the combatants objective be to move the contact zone (FEBA) as much as possible from the friendly to the enemy territory, i.e. the distance of the FEBA-movement gained in a hostile territory determines the victorious combatant. Both sides engage armored ground forces and tactical air forces, i.e. the combatants in a sector are viewed as homogeneous forces, but consisting of at least four components as in our refined LARC formulations. The FEBA-movement function depends only on the force ratio of the armored ground forces. If these forces are equal no FEBA-movement occurs. Ground forces deliver "aimed" fire, air forces against ground forces "area" fire, and against air forces "aimed" fire. Both sides of air forces choose air war strategies, i.e. percentage allocation factors between air or ground targets. Ground and air forces of the combatants are enforced by constant replacement rates not subject to attrition. A conflict terminates, if a side records a FEBA-movement of 300 km or the battle lasts over 30 days or anyone of the forces reaches their breakpoints for a fight-to-the finish.

## 2. Model Equations and Notation

Denote blue ground forces by  $(X_1)$ , blue air forces by  $(Y_1)$  and equivalently  $(X_2)$  and  $(Y_2)$  for the red forces. Use the symbols  $(R_i)$  and  $(S_i)$  for  $i = 1, 2$  to indicate  $X$ 's and  $Y$ 's replacement rates. The fraction of air forces allocated to different strategies (air or ground combat) are  $(u)$  and  $(v)$  for  $X$  and  $Y$  air forces respectively. The gained FEBA-movement distance is denoted as  $(s)$ . Refined LARC (viewing each combat unit as a coherent system of the four components: hardware system, human interface, combat environment and logistics) are for  $X$  denoted by  $e_{ij}$  and for  $Y$  with  $f_{ij}$  for  $j = 1, 2$ . The value of the second subscript tells which force is firing to destroy a target accordingly to the value of the first subscript.

Fig 6 displays the opponents and their strategies for the attrition process. The following differential equations describe the combat dynamics (Note that for solving three of them fourth-order Runge-Kutta, compare [95], numerical integration approximations are applied in the FORTRAN Computer Program attached in Appendix A).

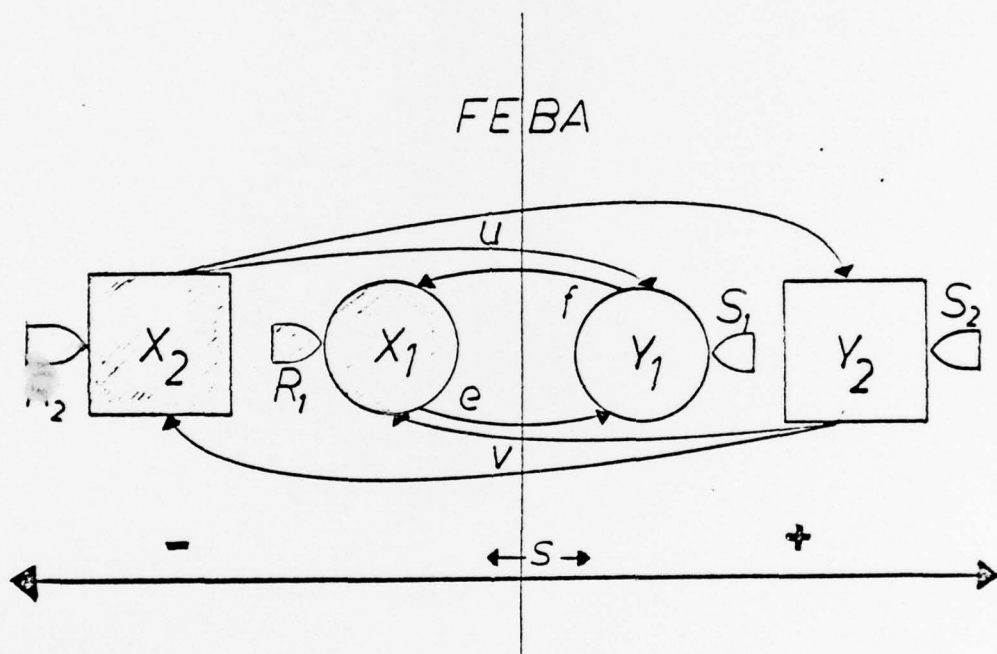

Figure 6 - ATTRITION PROCESSES AND BATTLE OUTCOMES  
ABSTRACTED WITH A DIFFERENTIAL MODEL

Functional Criterion

$$s(t) = \int_0^z [(h [x_1(z)/y_1(z) - 1] + k) dz$$

with constants h and k and t indicating the time dependence

FEBA-movement model

$$ds/dt = (h (x_1/y_1) - 1) + k$$

Ground war

$$dx_1/dt = R_1 - f_{11} y_1 - v f_{12} y_2 x_1$$

$$dy_1/dt = S_1 - e_{11} x_1 - u e_{12} y_1 x_2$$

Air war

$$dx_2/dt = R_2 - (1-v) f_{22} y_2$$

$$dy_2/dt = S_2 - (1-u) e_{22} x_2$$

with  $x_i, y_i > 0$  and  $0 < u, v < 1$ .

Appendix A includes a FORTRAN program that can be exercised for a set of input parameters (including the initial conditions for the differential equations). Numerical results in simulating different contingencies with this program are easily obtainable. The main concern of this thesis was not to exercise a first-cut differential sector model of warfare. However, we like to demonstrate with these concise mathematical formulations and the FORTRAN program that the main effort for successful combat modelling must not be spent in the final building and computer implementation and exercising phase. Professional combat

model builder are very efficient with this regard. The most crucial and critical part for a combat model is the early stage of its design. Only some equations stand for the whole spectrum and complexity of abstract formulations of General-Purpose-Forces problems in a final model. A simple program code allows us to solve this system of equations. The magnitude of model input parameters determine the range of the numerical values of battle predictions for a theater (in our example a sector) level scenario. Despite of this significance of inputs into model equations we felt that it was necessary to address some basic questions like "How", "Where" and "Why" have some numbers been chosen to express the effectiveness of forces that are the model driving inputs. LATMW are then easily exercised with the aid of a digital computer. Finally, we hope that the variety of our General and Specific Modelling Considerations help to remind where one has to start to successfully apply Operations Research Methods: first of all, identify those conditions to numerically sound, and hence scientifically abstract the real world phenomena.

#### IV. SUMMARY AND CONCLUSIONS

The cost/effectiveness evaluation of alternative strategies and tactics for General-Purpose Forces for a Theater-Level Campaign is a very complex and difficult task. Because of this fact, various dangers exist for committing pitfalls and shortcomings in model constructions. There are many "standard" mistakes that may be made in building a model. These are principally related to the process of abstracting and aggregating combat phenomena in theater-level operations. The main thrust of this thesis has been to establish a Minimum Evaluation Framework (MEF) for combat models. This MEF provides guidance as to the maximum amount of abstraction and aggregation that yield "acceptable" results in modelling combat.

Based on our readings and much contemplative reflection, we feel that one should explicitly focus on the following topic areas before starting to build a combat model:

1. Abstraction of the overall structure of the combined arms forces (viewed as coherent systems), i.e. the study of the systems' structure function and those of their components (branches and other combat influencing phenomena) that constitute combat dynamics.
2. Aggregation of the quantification (numerical descriptors) of all system component state outcomes (functioning or failure), i.e. to obtain measures (from either soft and/or hard information) of how well do components function (reliability) and allow to perform (availability) interrelated combat actions with systems such as modern combined arms forces.

3. Utilization of easily applicable mathematical and statistical methods tailored to abstract and quantify combat processes with also cheap data collection procedures that permit to extract the worth of these systems in duels.
4. Consistent orientation of the analytical formulations that use the quantified measures of effectiveness on the desired and defined analysis objective, i.e. the cost effective evaluation of alternative strategies and tactics achievable with the spectrum of modern conventional forces.
5. Validation and verification of all assumption and formulations that went into a complex model before it is implemented to assist in Cost Operational Effectiveness Analysis (COEA) Studies.

All these considerations have to be laid out and viewed together before the model building even starts. Military experts, scientists and managers are then able, as a team, to adjust unsound assumptions and formulations or to call for more detailed research on problem areas. State-of-the-art combat models (because of their model designs) have concentrated with different weights with regard to the above aspects to produce qualitatively (scientifically) acceptable abstractions and quantifications of military engagements. For example, some model builders focus primarily on hardware problems, some on particular branch oriented questions, and others use unsound methods to aggregate numerical inputs in a complex model.

Therefore, minimum bounds to adequately formulate combined arms actions in a theater-level scenario have to be established in order to be able to really address General-Purpose-Force problems with combat models. One has to specify these in a Minimum Evaluation Framework for

combat models that guide combat modellers to achieve this specifications in models. This will hopefully yield scientifically sound abstractions of the alternative worth to operate complex military units with different capabilities, reliabilities and availabilities, and various strategies and tactics. The deployed systems on a battlefield are then expressible as very coherent ones that include all decisive components (e.g. hardware systems, human interface, logistical consumption, resource allocation, combat environment). This directs us also to consistent system effectiveness quantifications oriented on the desired analysis goal. Capability, availability and reliability measures of systems (obtainable with means of our Concept of Estimable Rates) refine Lanchester Attrition-Rate Coefficients (LARC) as suitable inputs for LATMW to evaluate alternative systems and their effectiveness in possible scenarios. We are therefore able to study the consumption of limited resources by conventional forces. This is accomplished with an Input-Output Analysis that considers not only costs, but also their economic impact in a country.

All these specific modelling considerations concentrate on achieving the desired analysis objective, i.e. from the plan to collect data (to extract information about the worth of systems) to the final formulation of LATMW and Input-Output models for COEA studies. If one follows our considerations for modelling efforts this will hopefully produce differential combat models of real operational use for quantitatively analyzing General-Purpose-Force problems. Basically, we have provided guidance to overcome shortcomings and pitfalls of model assumptions, formulations and techniques to be applied in LATMW.

We have also identified in this thesis areas for future research. If this research were to be done, then hopefully differential combat modelling would cease to primarily be viewed as an art that tries to appeal ambitious customers that argue with different reservations to choose differential models as aids for an analysis. Systematic and scientific planning towards a desired objective will produce fruitful results. The rigorous use of the Scientific Method allows us to put each step of such plans into realization (to construct a complex verifiable and validiable LATMW). The worth of the Scientific Method, in our particular case, in exercising LATMW is to lay out numerically quantified alternative combat outcomes. However, the final decision as to which strategy and tactic ought to be chosen is, of course, left to the discernment of the decision maker.

## APPENDIX A

### FORTRAN PROGRAM FOR A SECTOR LATMW

This example FORTRAN program (included hereafter) for the theater level sector LATMW formulated in III.H. should only be exercised and used as a tool for any further analysis, if valid inputs can be supplied, i.e. with estimated refined LARC, force levels and their replacement rates. Military decision maker and planners will then with the simulation of this routine obtain numerical aids to assess the cost effects of different strategies and tactics according to their predicted scenarios.

```

//TPHERB JOB (0178,0333,RZ52),SMC 1987',TIME=1
// EXEC FORTCLG,REGION.GO=80K
//FORT. SYSIN DD *
COMMON/BL6/XTIME(25),SS(25)
COMMON/BL7/X1(25),Y1(25)
COMMON/BL8/IFLAG,ICHECK,KOUNT,ISTEP,NFLAG
COMMON/BL9/NSTEP
COMMON/BL10/RK(3,7)
COMMON/BL11/Y2(25)
COMMON/BL12/X2(25)
COMMON/BL13/N
COMMON/BL16/TSTOP
COMMON/BL17/V
COMMON/BL18/U
COMMON/BL20/DAY
COMMON/BL24/INDEX
COMMON/BL25/MDAY
COMMON/BL26/MIN,IOUT
C NR OF DIFFERENT RUNS.EQ.LAST
C DATA LAST,INPU/10,1/
C INDICATE TYPE OF OUTPUT WANTED
C NFLAG=1 ONLY TABLE OF BATTLEHISTORY
C NFLAG=2 TABLE AND PLOT OF BATTLEHISTORY
NFLAG=1
C IFLAG=0 ONLY TABLE PER DAY
C IFLAG=1 TABLE AND PLOT PER DAY
C IFLAG=2 SUPPRESS BOTH
IFLAG=2
C INITIAL CONDITION FOR ALL RUNS
NSTEP=1
MCAY=0
CALL INPUT
C INITIAL CONDITION FOR EACH RUN
10 CAY=1.0
KCLNT=1
ISTEP=0
MIN=1
IF(INPU.EQ.1) GO TO 60
DO 99 IR=1,N
RK(1,1)=X1(1)
RK(2,2)=Y1(1)
RK(3,2)=SS(1)
C AIRSTRATEGIES
60 V = V-0.1
U=U-0.1
C INITIALISATION FOR EACH TIMESTEP
20 NSTEP=NSTEP+1

```

```

ICUT=0
IF(NSTEP.EQ.25) MDAY=1
KCUNT=KCUNT+1
ICHECK=1
C DETERMINE ANALYTICAL SOLUTION FOR DE
CALL ANASOL
C DETERMINE NUMERICAL SOLUTION FOR DE
CALL NUMSOL
C TEST OF BATTLE STOPPING RULES
IF(SS(NSTEP).GE.300.0.OR.SS(NSTEP).LE.-300.0) GO TO 30
IF(RK(1,1).GT.TSTOP) GO TO 30
IF((X1(NSTEP).LE.0.0).OR.(Y1(NSTEP).LE.0.0).OR.
*(Y2(NSTEP).LE.0.0).OR.(X2(NSTEP).LE.0.0)) GO TO 30
C OUTPUT PER BATTLEDAY
IF(KCUNT.GT.24) GO TO 50
GO TO 20
C PLOT TWO OUTPUTS PER PAGE
50 IF((INDEX-(2*(INDEX/2))).EQ.0) IOUT=1
C PRINT TABLES AND/OR GRAPHS
CALL OUTPUT
GO TO 20
C OUTPUT CALLED DUE TO BATTLETERMINATION RULES
30 ICHECK=0
ICUT=1
CALL OUTPUT
IF(INPU.EQ.LAST) GO TO 40
INPU=INPU+1
GO TO 10
40 STOP
END
SUBROUTINE INPUT
COMMON/BL1/R2,S2,A22,B22,TI
COMMON/BL2/ALPHA1,ALPHA2,RON
COMMON/BL3/S1,B11,B12
COMMON/BL4/R1,A11,A12
COMMON/BL5/XX2(25),YY2(25)
COMMON/BL6/XTIME(25),SS(25)
COMMON/BL7/X1(25),Y1(25)
COMMON/BL10/RK(3,7)
COMMON/BL11/Y2(25)
COMMON/BL12/X2(25)
COMMON/BL13/N
COMMON/BL15/DELTAT
COMMON/BL16/TSTOP
COMMON/BL17/V
COMMON/BL18/U
COMMON/BL21/THIST(31)
COMMON/BL22/XIHIST(31),YIHIST(31),SHIST(31)

```

```

C CMMON/BL23/X2HIST(31),Y2HIST(31)
C NR OF EQUATIONS FOR NUMSOL = N
C DATA IN/3/
C RATES FOR ANASOL (X2,Y2)
C DATA DR2,DS2,DA22,DB22/1.0,1.0,0.08,0.16/
C RATES FOR NUMSOL (X1,Y1)
C DATA DR1,DA11,DA12,DS1,DB11,DB12/50.0,
#0.01,0.02,100.0,0.002,0.04/
C COEFFICIENTS FOR FEBA MOVEMENT EQUATION S
C DATA ALFA1,ALFA2,DRON/25.0,0.0,1.0/
C AIR WAR STRATEGIES
C DATA DU,DV/1.0999,1.0999/
C SET INPUT TO INITIALISATION
N=IN
R2=DR2
S2=DS2
A22=DA22
B22=DB22
R1=DR1
A11=DA11
A12=DA12
S1=DS1
B11=DB11
B12=DB12
ALPHA1=ALFA1
ALPHA2=ALFA2
KCN=DRON
U=DU
V=DV
200 WRITE(6,1),5X,'INITIAL CONDITIONS FOR INFANTRY AND A/C STRENGTH',/,
*6X,'FOR X AND Y FORCES ARE PRINTED IN THE FIRST LINE OF THE OUTPUT',
*UT TABLE,/,)
210 WRITE(6,2,10)R1,S1,R2,S2
WRITE(6,2,10)R1,S1,R2,S2
*6X,'REPLACEMENT RATE FOR X INFANTRY',F6.1,/,
*6X,'REPLACEMENT RATE FOR Y INFANTRY',F6.1,/,
*6X,'REPLACEMENT RATE FOR X A/C',5X,F6.1,/,
*6X,'REPLACEMENT RATE FOR Y A/C',5X,F6.1,/,)
220 WRITE(6,2,20)A11,B11,A12,B12,A22,B22
WRITE(6,2,20)A11,B11,A12,B12,A22,B22
*6X,'Y INF AGAINST X INF',F12.7,/,
*6X,'X INF AGAINST Y INF',F12.7,/,
*6X,'Y A/C AGAINST X A/C',F12.7,/,
*6X,'X A/C AGAINST Y A/C',F12.7,/,
*6X,'X A/C AGAINST Y A/C',F12.7,/,)
C COLUMN2 OF KK = INITIAL CONDITIONS FOR N FUNCTIONS AT TIME ABOVE
READ(5,101)(RK(IR,2),IR=1,N)

```

```

101 FORMAT(3F9.1)
C COLUMN1 OF RK = INITIAL CONDITIONS FOR TIME
DO 99 IR=1,N
99 RK(IR,1)=0.0
C READ INITIAL CONDITIONS FOR ANASOL
READ(5,102)X2(1),Y2(1)
102 FORMAT(2F6.1)
C READ TIMESSTEP AND TIME OF BATTLE TERMINATION
READ(5,103)DELTA,TSTOP
103 FORMAT(F9.7,F5.1)
C STORE INITIAL CONDITIONS FOR PLOTS AND TABLES
C ARRAY HORIZONTAL AXIS
XTIME(1)=RK(1,1)
THIST(1)=RK(1,1)
C ARRAYS VERTICAL AXIS
X1(1)=RK(1,2)
X1HIST(1)=RK(1,2)
Y1(1)=RK(2,2)
Y1HIST(1)=RK(2,2)
SS(1)=RK(3,2)
SHIST(1)=RK(3,2)
XX2(1)=X2(1)
XX2HIST(1)=X2(1)
YY2(1)=Y2(1)
YY2HIST(1)=Y2(1)
RETURN
END
SLBROUTINE ANASOL
COMMON/BL1/K2,S2,A22,B22,T1
COMMON/BL5/XX2(25),YY2(25)
COMMON/BL6/XTIME(25),SS(25)
COMMON/BL9/NSTEP
COMMON/BL10/RK(3,7)
COMMON/BL11/Y2(25)
COMMON/BL12/X2(25)
COMMON/BL13/N
COMMON/BL14/X2X,Y2Y
COMMON/BL15/DELTA
COMMON/BL17/V
COMMON/BL18/U
COMMON/BL20/DAY
COMMON/BL21/THIST(31)
COMMON/BL23/X2HIST(31),Y2HIST(31)
COMMON/BL24/INDEX
COMMON/BL25/MDAY
IF(NSTEP.EQ.2) GO TO 10
GC TO 20
10 VC=1.0-V

```

```

UC=1.0-U
20 TI=RK(1,1)+DELTAT
C SAVE XTIME(NSTEP)=TI
C ANALYTICAL SOLUTION FOR PLOTS PER DAY
A=SQRT(VC*UC*A22*B22)
C=COSH(A*TI)
CC=X2(1)*C
D=(R2-(Y2(1)*VC*A22))/A
E=SINH(A*TI)
F=Y2(1)*C
G=(S2-(X2(1)*UC*B22))/A
Y2(NSTEP)=F+(G*E)
XX2(NSTEP)=X2(NSTEP)
YY2(NSTEP)=Y2(NSTEP)
IF(MDAY.EQ.1) GO TO 30
GC TO 40
30 CAY=DAY+1.0
INDEX=INT(DAY)
C SAVE VALUES FOR PLOT PER BATTLE
X2HIST(INDEX)=X2(NSTEP)
Y2HIST(INDEX)=Y2(NSTEP)
THIST(INDEX)=TI
C ANALYTICAL SOLUTION FOR (TIME + DELTAT/2.0)
40 TI=RK(1,1)+DELTAT/2.0
C=COSH(A*TI)
CC=X2(1)*C
E=SINH(A*TI)
X2X=CC+(D*E)
F=Y2(1)*C
Y2Y=F+(G*E)
C UPDATE TIME FOR NEXT STEP
DO 99 IR=1,N
99 RK(IR,1)=RK(IR,1)+DELTAT
RETURN
END
SUBROUTINE NUMSOL
COMMON/BL6/XTIME(25),SS(25)
COMMON/BL7/XI(25),YI(25)
COMMON/BL9/NSTEP
COMMON/BL10/RK(3,7)
COMMON/BL13/N
COMMON/BL15/DELTAT
COMMON/BL19/IK
COMMON/BL20/DAY
COMMON/BL22/XIHIST(31),YIHIST(31),SHIST(31)
COMMON/BL24/INDEX

```

```

CCMMON/BL25/MDAY
DUMMY=0.0
DO 990 IK=3,6
RK(1,IK)=HOFX1(DUMMY)
RK(2,IK)=GOFY1(DUMMY)
990 RK(3,IK)=FOFRO(DUMMY)
      RK(1,7)=RK(1,2)+((DELTAT/6.0)*(RK(1,3)+(2.0*(RK(1,4)+RK(1,5))))+
      *RK(1,6))
C SAVE VALUES FOR PLOTS PER DAY
  X1(NSTEP)=RK(1,7)
  RK(2,7)=RK(2,2)+((DELTAT/6.0)*(RK(2,3)+(2.0*(RK(2,4)+RK(2,5))))+
  *RK(2,6))
C SAVE VALUES FOR PLOTS PER DAY
  Y1(NSTEP)=RK(2,7)
  RK(3,7)=RK(3,2)+((DELTAT/6.0)*(RK(3,3)+(2.0*(RK(3,4)+RK(3,5))))+
  *RK(3,6))
C SAVE VALUES FOR PLOTS PER DAY
  SS(NSTEP)=RK(3,7)
C SAVE VALUES FOR PLOTS PER BATTLE
  IF(MDAY.EQ.1) GO TO 10
  GO TO 20
10 X1HIST(INDEX)=X1(NSTEP)
  Y1HIST(INDEX)=Y1(NSTEP)
  SHIST(INDEX)=SS(NSTEP)
C UPDATE RK MATRIX FOR NEXT STEP
20 DO 980 IR=1,N
980 RK(IR,2)=RK(IR,7)
RETURN
END
FUNCTION HOFX1(DUMMY)
CCMMGN/BL4/R1,A11,A12
CCMMON/BL9/NSTEP
CCMMGN/BL10/RK(3,7)
CCMMON/BL11/Y2(25)
CCMMON/BL14/X2X,Y2Y
CCMMON/BL15/DELTAT
CCMMON/BL17/V
CCMMON/BL19/IK
DT=DELTAT
DTH=DELTAT/2.0
IF(IK.EQ.3) GO TO 10
IF(IK.EQ.4) GO TO 20
IF(IK.EQ.5) GO TO 30
C K4 HUFX1=R1-(A11*(RK(2,2)+(DT*RK(2,5))))-
      *(V*A12*Y2(NSTEP)*(RK(1,2)+(DT*RK(1,5))))
RETURN
C K1

```

```

10 HOFX1=R1-(A11*RK(2,2))-(V*A12*RK(1,2)*Y2(NSTEP-1))
   RETURN
C K2
20 HOFX1=R1-(A11*(RK(2,2)+(DTH*RK(2,3))))-
   *(V*A12*Y2Y*(RK(1,2)+(DTH*RK(1,3))))
   RETURN
C K3
30 HOFX1=R1-(A11*(RK(2,2)+(DTH*RK(2,4))))-
   *(V*A12*Y2Y*(RK(1,2)+(DTH*RK(1,4))))
   RETURN
END
FUNCTION GOFY1(DUMMY)
COMMON/BL3/S1,B11,B12
COMMON/BL9/NSTEP
COMMON/BL10/RK(3,7)
COMMON/BL12/X2(25)
COMMON/BL14/X2X,Y2Y
COMMON/BL15/DEL TAT
COMMON/BL18/U
COMMON/BL19/IK
DT=DEL TAT
DTH=DEL TAT/2.0
IF(1K.EQ.3) GO TO 10
IF(1K.EQ.4) GO TO 20
IF(1K.EQ.5) GO TO 30
C K4
GCFY1=S1-(B11*(RK(1,2)+(DT*RK(1,5))))-
*(U*B12*(RK(2,2)+(DT*RK(2,5))))*X2(NSTEP)
   RETURN
C K1
10 GOFY1=S1-(B11*RK(1,2))-(U*B11*RK(2,2)*X2(NSTEP-1))
   RETURN
C K2
20 GOFY1=S1-
*(B11*(RK(1,2)+(DTH*RK(1,3))))-
*(U*B12*(RK(2,2)+(DTH*RK(2,3))))*X2X
   RETURN
C K3
30 GOFY1=S1-(B11*(RK(1,2)+(DTH*RK(1,4))))-
*(U*B12*(RK(2,2)+(DTH*RK(2,4))))*X2X
   RETURN
END
FUNCTION FOFRO(DUMMY)
COMMON/BL2/ALPHA1,ALPHA2,RON
COMMON/BL10/RK(3,7)
COMMON/BL15/DEL TAT
COMMON/BL19/IK
DT=DEL TAT

```

```

DTH=DELTA T/2.0
AL1=ALPHA1
AL2=ALPHA2
IF(IK.EQ.3) GO TO 10
IF(IK.EQ.4) GO TO 20
IF(IK.EQ.5) GO TO 30

C K4
FGFRO=(AL1*((RK(1,2)+(DT*RK(1,5))))/
*(RK(2,2)+(DT*RK(2,5))))-RON)+AL2
RETURN

C K1
FGFRO=(AL1*((RK(1,2)/RK(2,2))-RON))+AL2
RETURN

C K2
FGFRO=(AL1*((RK(1,2)+(DTH*RK(1,3))))/
*(RK(2,2)+(DTH*RK(2,3))))-RON)+AL2
RETURN

C K3
FGFRO=(AL1*((RK(1,2)+(DTH*RK(1,4))))/
*(RK(1,2)+(DTH*RK(2,4))))-RON)+AL2
RETURN
END
SUBROUTINE OUTPUT
COMMON/BL5/XX2(25),YY2(25)
COMMON/BL6/XTIME(25),SS(25)
COMMON/BL7/X1(25),Y1(25)
COMMON/BL8/IFLAG,ICHECK,KOUNT,ISTEP,NFLAG
COMMON/BL9/NSTEP
COMMON/BL17/V
COMMON/BL18/U
COMMON/BL21/THIST(31)
COMMON/BL22/X1HIST(31),Y1HIST(31),SHIST(31)
COMMON/BL23/X2HIST(31),Y2HIST(31)
COMMON/BL24/INDEX
COMMON/BL25/MDAY
COMMON/BL26/MIN,IOUT
ISTEP=ISTEP+NSTEP
IF(ISTEP.GT.25) MIN=MIN+1
MSTEP=ISTEP-MIN
IF(ICHECK.EQ.0) GO TO 30
IF(IFLAG.EQ.2) GO TO 80
IF(IFLAG.EQ.1) GO TO 40
IF(IOUT.EQ.0) GO TO 70
WRITE(6,200)MSTEP
GC TO 60
70 WRITE(6,210)MSTEP
60 WRITE(6,201)((XTIME(I),X1(I),Y1(I),XX2(I),YY2(I),SS(I)),I=1,KOUNT)

```

```

80 IF(ICHECK.EQ.1) KOUNT=1
   IF(IFLAG.EQ.1) GO TO 10
   GO TO 20
10 IF(KOUNT.EQ.1) GO TO 20
   MDCUR=0
   WRITE(6,202)
   CALL PLOTP(XTIME,X1,NSTEP,MODCUR)
   WRITE(6,220)
   CALL PLOTP(XTIME,Y1,NSTEP,MODCUR)
   WRITE(6,203)
   CALL PLOTP(XTIME,XX2,NSTEP,MODCUR)
   WRITE(6,230)
   CALL PLOTP(XTIME,YY2,NSTEP,MODCUR)
   WRITE(6,204)
   CALL PLOTP(XTIME,SS,NSTEP,MODCUR)
   FORMAT(1,7X,TIME OF INF X NR OF INF Y NR OF INF PER DAY STEPS,
   *16,/)
200 *NR OF A/C DISTANCE EVALUATED PER DAY STEPS,
   *16,/)
201 FCRMAT(6X,F9.4,F15.4,F17.4,F14.4) X',
210 FCRMAT(0,7X,TIME OF A/C DISTANCE EVALUATED PER DAY STEPS,
   *16,/)
202 FCRMAT(1,5X,X INFANTRY EVALUATED IN 24 TIMESTEPS PER DAY,I4)
220 FCRMAT(1,5X,Y INFANTRY EVALUATED IN 24 TIMESTEPS PER DAY,I4)
230 FCRMAT(1,5X,X A/C EVALUATED IN 24 TIMESTEPS PER DAY,I4)
204 FCRMAT(1,5X,Y A/C EVALUATED IN 24 TIMESTEPS PER DAY,I4)
   *6X, POSITIVE VALUES INDICATE GAIN OF X TERRAIN I.E. X WINS,
   *6X, NEGATIVE VALUES INDICATE GAIN OF Y TERRAIN I.E. Y WINS,
240 FCRMAT(0,5X,PERCENTAGE OF X A/C ENGAGED IN GROUNDWAR,F8.4,/,
   *6X,PERCENTAGE OF Y A/C ENGAGED IN GROUNDWAR,F8.4,/)
20 NDAY=1
RETURN
C BATTLE HISTORY
30 MN=INDEX-1
   IF(INDEX.LE.1) GO TO 40
   WRITE(6,300)MN
   *Y2HIST(1),SHIST(1),I=1,INDEX)
   WRITE(6,240)U,V
C NC PLOT OF BATTLE HISTORY WANTED
   IF(INFLAG.EQ.1) GO TO 50
   MDCUR=0
   WRITE(6,301)
   CALL PLOTP(THIST,XIHIST,INDEX,MODCUR)
   WRITE(6,302)
   CALL PLOTP(THIST,YIHIST,INDEX,MODCUR)

```

```

WRITE (6,303)
CALL PLOTP(THIST,X2HIST,INDEX,MODCUR)
WRITE (6,304)
CALL PLOTP(THIST,Y2HIST,INDEX,MODCUR)
WRITE (6,305)
CALL PLOTP(THIST,SHIST,INDEX,MODCUR)
FORMAT(1,7X,'TIME OF A/C',X NR OF INF, Y NR OF INF, X',
*16,' BATTLE DAYS STEPS, (/)
300 FORMAT(1,5X,'X INFANTRY EVALUATED BATTLE PRO DAY',)
301 FORMAT(1,5X,'Y INFANTRY EVALUATED BATTLE PRO DAY',)
302 FORMAT(1,5X,'X A/C EVALUATED BATTLE PRO DAY',)
303 FORMAT(1,5X,'Y A/C EVALUATED BATTLE PRO DAY',)
304 FORMAT(1,5X,'GAINED DISTANCE BATTLE PRO DAY',)
305 *6X,' POSITIVE VALUES INDICATE GAIN OF Y TERRAIN I.E. X WINS',/,
*6X,' NEGATIVE VALUES INDICATE GAIN OF X TERRAIN I.E. Y WINS',/,
50 NSTEP=1
MLAY=0
RETURN
END
//GO.SYSIN DD *
60000.0 35000.0 0.0
150.0 50.0
0.0416667 30.0

```

#### LIST OF REFERENCES

1. Hitch Ch. J. and McKean R. N., The Economic of Defense in the Nuclear Age, p.3, Atheneum New York, 1974.
2. K. Tsipis, "The Calculus of Nuclear Counterforce", Technology Review, v. II. number 1, p. 34-43, October, November 1974.
3. Mansfield E., Microeconomics, Theory and Applications, Norton & Company Inc New York, 1970.
4. Bowers D. A. and Baird R. N., Elementary Mathematical Macroeconomics, Prentice-Hall, Inc, 1971.
5. Kogiku K. C., Microeconomic Model, , p. 161-178, Harper & Row, 1971.
6. Office of the Assistant Secretary of Defense (Systems Analysis), PLANNING PROGRAMMING AND BUDGETING UNDER THE NEW LAIRD PACKARD FISCAL CONSTRAINTS THE ROLE OF THE ELECTRIC FYDP SYSTEM, by G. T. Patton, Ch. L. Snyder Jr. and R. W. Szymkowski, Fifth Annual Cost Analysis Symposium in Gaithersburg, Maryland, p. 363-400, 1970.
7. Interindustry Economics Division The Input-Output Structure of the U. S. Economy: 1967, in Survey of Current Business, v. 54 number 2, p. 24-56, February 1974.
8. Morse Ph. M. and Kimball G. E., Methods of Operations Research, M. I. T. Press, p. 1, Tenth Printing 1970.
9. Blechman B.M., Gramlich E. M. and Hartman R. W. SETTING NATIONAL PRIORITIES THE 1976 BUDGET, THE BROOKINGS

INSTITUTION, 1975.

10. Enthoven A. C. and Smith K. W. "How much is enough?" , Harper & Row, 1971.
11. RAND-DEFENSE ADVANCE RESEARCH PROJECTS AGENCY R-1088-ARPA, NATO Military Policy: Obtaining Conventional Comparability with the Warsaw Pact, p. 75, June 1973.
12. Steinhoff J., Wohin treibt die NATO? Probleme der Verteidigung Westeuropas, p. 65, Hoffmann und Campe Verlag, Hamburg West-Germany, 1976.
13. Theo Sommer, "Aufrüstung-wozu?", Die Zeit, Nummer 20, p. 1, 14. Mai 1976.
14. Don Cook, "Soviet get blunt warning", MONTEREY PENINSULA HERALD p. 1, 22. May 1976.
15. US Army Concepts Analysis Agency, "Proceedings Thirteenth Annual US Army Operations Research Symposium", v. I-II, 1974.
16. US Army Concepts Analysis Agency, "Proceedings Fourteenth Annual US Army Operations Research Symposium", v. I-II, 1974.
17. Huber R. K., Jones L. F. and Reine E. Military Strategy and Tactics , Plenum Press, 1975.
18. Taylor J. G. and Parry S. H., "Force-Ratio Considerations for Some Lanchester-type Models of Warfare", Opns. Res. 23, p. 522-533, May-June 1975.
19. Taylor J. G., "ON THE RELATIONSHIP BETWEEN THE FORCE RATIO AND THE INSTANTANEOUS CASUALTY-EXCHANGE RATIO FOR SOME LANCHESTER-TYPE MODELS OF WARFARE, Naval Res. Log. Quart., v. 23. number 2, 1976.
20. Bonder S., "AN OVERVIEW OF LAND COMBAT MODELING IN THE

- US," Proc. U.s. Army Opns. Res. Sympos., p. 73-88, 1974.
21. UNITED STATES AIR FORCE PROJECT RAND, R-1526-PR, Models, Data, and War: A Critique of the Study of Conventional Forces, by J.A. Stockfisch, March 1975.
  22. United States Concepts Analysis Agency, Geneology of models, May 1973.
  23. General Research Corporation Operations Analysis Division, A Hierarchy of Combat Analysis Models, January 1973.
  24. Bonder S., "The Lanchester Attrition-Rate Coefficient", Opns. Res. 15, p. 221-232, 1967.
  25. Bonder S., "The Mean Lanchester Attrition Rate", Opns. Res. 18, p. 179-181, 1970.
  26. Barfoot C., "The Lanchester Attrition-Rate Coefficient: Some Comments on Seth Bonder's Paper and a Suggested Alternate Method", Opns. Res. 17, p. 888-894, 1969.
  27. Clark G. M., The Combat Analysis Model, Ph. D. Dissertation, The Ohio State University, Columbus Ohio, 1968.
  28. Lanchester F. W., "Aircraft in Warfare: The Dawn of the Fourth Arm, No. V., The Principle of Concentration.", Engineering 98, p. 422-423, 1914 (reprinted on p. 2138-2148 (see also p. 2148-2157) of The World of Mathematics, v. IV, J. Newman (Ed.), Simon and Schuster, New York, 1956).
  29. Taylor J. G., "A TUTORIAL ON LANCHESTER-TYPE MODELS OF WARFARE", Proc. 35th Mil. Opns. Res. Sympos., p. 39-63, July 1975.
  30. Dixon W. J. and Massey F. J., Introduction to Statistical Analysis, p. 4-7, McGraw Hill, 1969.

31. Searle S. R. Linear Models, p. 135-162, Wiley, 1971.
32. Hadley G. Linear Programming, Addison-Wesley, 1963.
33. Larson H.J. Introduction to Probability Theory and Statistical Interference, Wiley, 1974.
34. Fischer G. H., Cost Considerations in Systems Analysis, American Elsevier, 1973.
35. Quade E. S. and Boucher W. I., Systems Analysis and Policy Planning APPLICATIONS IN DEFENSE, American Elsevier, 1974.
36. Anthony R. N. and Hekimian J. S., Operations Cost Control, Irwin, 1967.
37. Belden D. L. and Cammack E. G., National Security Management PROCUREMENT, Industrial College of the Armed Forces Washington D.C., 1973.
38. Luenberger D. G., Introduction to linear and nonlinear programming, Addison-Wesley, 1973.
39. Wagner H. M., Principles of Operations Research with Applications to Managerial Decisions, Prentice-Hall, 1975.
40. BALFRAM (Balanced Force Requirement Analysis Methodology), Stanford Research Institute Technical Note NWRC-TN-52, User Manual for the Staff of the Commander in Chief Pacific, 1974.
41. Institute of Combined Arms and Support, Fort Leavenworth, Kansas DD number A D 823078, DIVTAG, A war game model for evaluation of combat developments tactical doctrine division through army group.
42. Vector Research, Inc., VECTOR-O, The BATTLE Model Prototype, v. I-V, Weapon Systems Evaluation Group (WESEG), Report No. 222, Arlington, Virginia, 1973.

43. Vector Research, Inc., VECTOR-1, A Theater Battle Model, v. I, Weapon Systems Evaluation Group (WESEG), Report No. 251, Arlington Virginia, 1974.
44. Vector Research, Inc., Briefing for 37th MORS Symp. on "VECTOR-2" (Theater-Level Campaign Model).
45. NATO STANDARDIZATION AGREEMENT (STANAG 2014)
46. U.S. Army Combat Developments Command Armor Agency, Systems Research Group under Contract DA 15-014 AII-2969, 10. I No K-11326-53, v. 1. p. 31.
47. Taylor J. G., "Considerations Under Which Various Lanchester-type Equations Have Been Hypothesized to Apply", unpublished Handout, NPS Monterey, Q3, FY 1976.
48. Taylor J. G. and Brown G. G., "An Examination of the Criterion Functional on Optimal Fire-Support Policies", NPGS Research Proj. No. RR014-11-01.
49. Taylor J. G., "Application of Differential Games to Problems of Military Conflict: Tactical Allocation Problems-Part III", NPS-55TW 74051, May 1974.
50. Taylor J. G., "Lanchester-Type Models of Warfare and Optimal Control", Naval Res. Log. Quart. 21, p. 673-697, 1973.
51. Weiss H., "Some Differential Games of Tactical Interest and the Value of a Supporting Weapon System", Opns. Res. 7, p. 180-196, 1959.
52. Sokolowskii V. D., Military Strategy, Foreign Technology Division Department of the Air Force, 1968.
53. Chase M. W., A Lanchester-type model with logistics consideration, M. S. Thesis, NPS Monterey, 1973.
54. Martray R. A., Development of an aggregated Lanchester-type combat model for the evaluation of

- air-war allocation strategies in a theater sector, M. S. Thesis, NPS Monterey, March 1976.
55. Hicks Ch. R., Fundamental Concepts in the Design of Experiments, Holt, Rinehart and Winston, 1973.
  56. Dixon W. J., Introduction to Statistical Analysis, McGraw-Hill, 1969.
  57. Bross P. J. "Cannon Launched Guided Projectile", A Critical Examination of the CLGP COEA, unpublished paper, 1. June 1976 submitted to Prof. Parry S. H., NPS Monterey, July 1976.
  58. Vector Research Incorporated, "Role and Use of Differential Models".
  59. Institute for Defense Analysis Program Analysis Division, ("IDAGAM I"), v. 1: Comprehensive Description, October 1974.
  60. Ketrion Inc., Results of a Survey of Tactical Air Campaign Models, Contract No. ACDA/PAB-249, November 1974.
  61. Berkovitz L. and Dresker M., "A Game Theory Analysis of Tactical Air War", Opns. Res. 7, p. 599-620, 1959.
  62. Isaacs R., Differential Games, Wiley, 1965.
  63. Bonder-IUA model or Aircav 5 model.
  64. Cox D. R., Renewal Theory, Science Paperbacks, Barnes & Noble, 1970.
  65. Barlow R. E. and Proschan F., Statistical Theory of Reliability and Life Testing Probability Models, Holt, Rinehart and Winston, 1975.
  66. Weapon System Effectiveness Industry Advisory Committee WSEIAC, Final Reports AFSC-IETR-65-1,2,3,4,5,6, January 1965.

67. Van Alven and William H., Reliability Engineering, Prentice-Hall, 1964.
68. Weapon System Effectiveness Industry Advisory Committee, Report AD 467816, 1965.
69. Esary J. D., "Relating Performance to a Complex System", unpublished Handout, NPS, Monterey.
70. Ketron, Inc., Fire Support Requirements Methodology Study Phase II, Proceedings of the Fire Support Methodology Workshop, KFR 57-75, 18 December 1975.
71. Weiss H. Lanchester-Type Models of Warfare, "Proceedings of the First International Conference on Operational Research", Wiley, 1957.
72. Gnedenko B., Belyayer J. and Solovyew A. D., Mathematical Methods of Reliability, Wiley, 1969.
73. Mil Std 785 DOD Reliability Program Requirements.
74. Meyer P. L., Introductory Probability and Statistical Applications, Addison-Wesley, 1970.
75. NAVWEPS OD 29304A Guide Manual for Reliability Measurement Program.
76. Lieberman G. L. and Ross S. M. "Confidence Intervals for Independent Systems", Journal of the American Statistical Association, v. 66, number 336, p. 837-840, December 1971.
77. Sakar T. K., "An Exact Lower Confidence Bound for the Reliability of a Series System when Each Component Has an Exponential Time to Failure Distribution", Report No. 117, Department of Operations Research and Department of Statistics, Stanford University, March 1969.
78. Butterworth R. W. and Marshall K. T., "A Survey of

Renewal Theory with Emphasis on Approximation, Bounds, and Applications", Technical Report, NPS - 55 BD 74051, Monterey, May 1974.

79. DYN TACS (Dynamic Tactical Simulation), U.S. Army Combat Developments Command Armor Agency Fort Knox, Kentucky 40121.
80. Meyer S. T. Data Analysis for Sciences and Engineers, Wiley, 1975.
81. Taylor J. G., "The Rate of Target Destruction-Part 3, unpublished Handout, NPS Monterey FY 1975.
82. Mar D.R., ASARS II PHASE II A STUDY OF THE USEFULNESS OF SUBJECTIVE CONTRAST RATINGS AND OF THE DIFFERENCES BETWEEN MORNING AND EVENING LOW LIGHT PERIODS, CDEC, Fort Ord, 1975.
83. Moder J. J. and Phillips C. R., Project Management with CPM and PERT, Van Nostrand Reinhold, 1970.
84. Comrey A. L., "A Proposed Method for Absolute Ratio Scaling", Psychometrika, v. 15, p. 317-325, 1950.
85. Torgerson W. S., Theory and Methods of Scaling, Wiley, 1958.
86. Duncan A. J., Quality Control and Industrial Statistics, Irwin, 1974.
87. Ross S. M., Introduction to Probability Models, Academic Press, 1970.
88. Butterworth R. W. and Nikolaisen T., "Bounds on the Availability Function", Naval Research Log. Quart. p. 289-296, 1972.
89. Kline M. B., "Application of the Lognormal Distribution to Maintainability Design", Logistics Spectrum, v. I, number 2, p. 13-20, 1967.

90. Ballistics Research Laboratory Aberdeen, "Point-Burst Model".
91. Bross P.J., Congestion Problems in Field Artillery Operations, M. S. Thesis, NPS Monterey, September 1976.
92. Khintchine A., Mathematical Methods in the Theory of Queueing, p. 23-36, Hafner, 1960.
93. Leontief W. W. and Hoffenberg M., "The Economic Effects of Disarmament", Scientific American, v. 204, number 4, p. 47-55, April 1961.
94. Read R. R., Lectures on Design of Experiments with Linear Models, unpublished notes by Mauerer H. H., 1976.
95. Arden B. W. and Astill K. N., Numerical Algorithms: Origins and Applications, Addison-Wesley, 1970.
96. Gaver D. P. and Thompson G. L., Programming and Probability Models in Operations Research, Wadsworth, 1973.
97. Lulejian and Associates, WSEG Report 227, Prototype of a Theater-Level Tactical Combat Model, v. 2. Model Logic and Equations, February 1974.
98. Stanford Research Institute, Naval Warfare Research Center, Technical Note NWRC-TN-59, Selection of a Method to Solve the N-Stage Game in BALFRAM, by Goheen L. C., August 1975.
99. Johnson J. E., A method of determining estimable functions and testable hypothesis in experimental design, M. S. Thesis, NPS Monterey, March 1976.
100. Lindsay G. L., Lectures on Obtaining Scale Values from Soft Information, unpublished notes by Mauerer H. H., 1976.

INITIAL DISTRIBUTION LIST

	No. Copies
1. Department Chairman, Code 55 Department of Operations Research Naval Postgraduate School Monterey, California 93940	2
2. Defense Documentation Center Cameron Station Alexandria, Virginia 22314	2
3. Library, Code 0212 Naval Postgraduate School Monterey, California 93940	2
4. DOKZENT BW Friedrich Ebert Allee 34 531 Bonn, West-Germany	2
5. Heeresamt BW Trajanstrasse 128 Koeln, West-Germany	2
6. Stanford Research Institute Naval Warfare Research Center Dir. Dr. Lawrence J. Low 333 Ravenswood Avenue Menlo Park, California 94025	1
7. Professor J. G. Taylor, Code 55Tw (thesis advisor) Department of Operations Research Naval Post Graduate School Monterey, California 93940	1

8. Professor S. H. Parry, Code 55Py 1  
Department of Operations Research  
Naval Post Graduate School  
Monterey, California 93940
9. Professor G. L. Lindsay, Code 55Ls 1  
Department of Operations Research  
Naval Post Graduate School  
Monterey, California 93940
10. Professor R. K. Huber 1  
Hochschule der Bundeswehr  
Fliegerhorst  
8014 Muenchen-Neubiberg  
West-Germany
11. Dr. H. Froehlich 1  
Fachhochschule des Heeres  
Dornheimer Weg 21  
Starkenbug Kaserne  
6100 Darmstadt  
West-Germany
12. Capt H. H. Mauerer, FGA (student) 1  
4129 El Bosque Drive  
Pebble Beach, California 93953

ATE  
LME