

AD-A038 673

DEFENSE SYSTEMS MANAGEMENT COLL, FORT BELVOIR VA  
OPERATIONS MANAGEMENT OF DOD SPACE MISSIONS IN THE SHUTTLE ERA. (U)  
NOV 76 C J TRINGALI

F/6 22/2

UNCLASSIFIED

NL

1 OF 2  
AD  
A038673



*DW*

# DEFENSE SYSTEMS

AD A 038673

# MANAGEMENT COLLEGE



## PROGRAM MANAGEMENT COURSE INDIVIDUAL STUDY PROGRAM

OPERATIONS MANAGEMENT OF DOD SPACE MISSIONS  
IN THE SHUTTLE ERA

Study Project Report  
PMC 76-2

CHARLES J. TRINGALI  
LtCol USAF

DDC  
RECEIVED  
APR 27 1977  
A

AD No. \_\_\_\_\_  
DDC FILE COPY

FORT BELVOIR, VIRGINIA 22060

DISTRIBUTION STATEMENT A  
Approved for public release;  
Distribution Unlimited

SECURITY CLASSIFICATION OF THIS PAGE (When Data Entered)

REPORT DOCUMENTATION PAGE		READ INSTRUCTIONS BEFORE COMPLETING FORM
1. REPORT NUMBER	2. GOVT ACCESSION NO.	3. RECIPIENT'S CATALOG NUMBER
4. TITLE (and Subtitle) <b>6</b> OPERATIONS MANAGEMENT OF DOD SPACE MISSIONS IN THE SHUTTLE ERA		5. TYPE OF REPORT & PERIOD COVERED <b>9</b> Student Project Report, 76-2
7. AUTHOR(s) <b>10</b> CHARLES J. TRINGALI		6. PERFORMING ORG. REPORT NUMBER
9. PERFORMING ORGANIZATION NAME AND ADDRESS DEFENSE SYSTEMS MANAGEMENT COLLEGE FT. BELVOIR, VA 22060		8. CONTRACT OR GRANT NUMBER(s)
11. CONTROLLING OFFICE NAME AND ADDRESS DEFENSE SYSTEMS MANAGEMENT COLLEGE FT. BELVOIR, VA 22060		10. PROGRAM ELEMENT, PROJECT, TASK AREA & WORK UNIT NUMBERS
14. MONITORING AGENCY NAME & ADDRESS (if different from Controlling Office) <b>14</b> Nov 76 <b>(12)</b> 107 p.		12. REPORT DATE 76-2
		13. NUMBER OF PAGES 102
		15. SECURITY CLASS. (of this report) UNCLASSIFIED
		15a. DECLASSIFICATION/DOWNGRADING SCHEDULE
16. DISTRIBUTION STATEMENT (of this Report) UNLIMITED <div style="border: 1px solid black; padding: 5px; display: inline-block;">DISTRIBUTION STATEMENT A Approved for public release; Distribution Unlimited</div>		
17. DISTRIBUTION STATEMENT (of the abstract entered in Block 20, if different from Report)		
18. SUPPLEMENTARY NOTES SEE ATTACHED SHEET		
19. KEY WORDS (Continue on reverse side if necessary and identify by block number) SEE ATTACHED SHEET		
20. ABSTRACT (Continue on reverse side if necessary and identify by block number)		

H10036

SB

DEFENSE SYSTEMS MANAGEMENT SCHOOL

STUDY TITLE: OPERATIONS MANAGEMENT OF DOD SPACE MISSIONS IN THE SHUTTLE ERA

STUDY PROJECT GOALS:

To present a history of the DOD/USAF Space Shuttle program to date and recommend an approach to future government space operations which offers maximum interagency cooperation in DOD mission accomplishment with the NASA.

STUDY REPORT ABSTRACT:

This report presents a history of the development of the Space Transportation System (STS) to date between the National Aeronautics and Space Administration (NASA) and the executive agency acting for the Department of Defense, the United States Air Force. The STS consists of the NASA-developed space shuttle orbiter, the USAF-developed upper stage, the communications networks and launch base complexes of both agencies, and the satellite payloads developed by many user agencies to be placed in space. The program development is traced chronologically in terms of key joint-agency agreements, management interfaces, and compromises made as implementation of early proposals was accomplished.

A proposal is made to develop a joint-agency STS operations authority responsive to national command/policy channels.

Key Words: Future Space Operations; Joint-agency Management

ACCESSION NO.	
NTIS	White Section <input checked="" type="checkbox"/>
DDC	Soft Section <input type="checkbox"/>
UNANNOUNCED	<input type="checkbox"/>
JUSTIFICATION	
BY	
DISTRIBUTION/AVAILABILITY STATEMENTS	
Dist.	AVAIL. NUMBER
A	

NAME, RANK, SERVICE  
CHARLES J. TRINGALI, LtCol, USAF

CLASS  
PMC 76-2

DATE  
10 November 1976

**OPERATIONS MANAGEMENT OF DOD SPACE MISSIONS  
IN THE SHUTTLE ERA**

**Study Project Report  
Individual Study Program**

**Defense Systems Management College  
Program Management Course  
PMC Class 76-2**

**by**

**CHARLES J. TRINGALI  
LtCol USAF**

**November 1976**

**Study Project Advisor  
Mr. Richard K. McIntosh**

**This study project report represents the views, conclusions and recommendations of the author and does not necessarily reflect the official opinion of the Defense Systems Management College or the Department of Defense.**

## EXECUTIVE SUMMARY

This report presents a history of the development of the Space Transportation System (STS) to date between the National Aeronautics and Space Administration (NASA) and the executive agency acting for the Department of Defense, the United States Air Force. The program development is traced chronologically in terms of the key joint-agency agreements, Management interfaces, and compromises made as implementation of early proposals was accomplished. A proposal is made to develop a joint-agency STS operations authority responsive to national command/policy channels.

The Space Transportation System is a vast national research and technology undertaking by NASA and USAF, comprising an expected budget expenditure of at least 10 billion in fiscal 1975 dollars through attainment of initial operational capability (IOC) for STS launches at Vandenberg AFB, California in FY 1983. Of this sum, NASA will expend 83%, or \$8.3 billion, and USAF the remainder.

The United States of America stands on the brink of a new space era. This era is made possible by the NASA-developed Space Shuttle orbiter; the USAF-developed upper stage; the supporting communication's networks and launch/recovery bases of both agencies, and the payloads or satellites placed accurately in space by this new system. As the STS operational phase evolves, the advantages of rapid, routine access to space coupled with greatly increased payload weight and volume will generate mission payloads yet unknown.

TABLE OF CONTENTS

<u>Section</u>	<u>Page</u>
Executive Summary . . . . .	ii
I INTRODUCTION . . . . .	1
II HISTORY OF THE STS PROGRAM . . . . .	4
III DOD/USAF/NASA/INTERAGENCY INTERFACES . . . . .	12
IV STS OPERATIONS ISSUES. . . . .	17
V CONSIDERING THE FUTURE: A RECOMMENDATION . . . . .	20
VI SUMMARY. . . . .	22
 <u>Appendix</u>	
A NASA/DOD Space Shuttle Program . . . . .	28
B STS Operation Concepts-Extracts. . . . .	29
C JSC/MCC Security Study . . . . .	30
D Minutes; SAMSO-OSF Meeting; 15 Jan 76. . . . .	31

## SECTION I

### INTRODUCTION

In his remarks during his mid-September 1976 visit to DSMC<sup>1</sup>, Dr. Malcolm R. Currie, ODDR&E, stated to the Program Management Course 76-2 student body:

" . . .there will be much increased space activity in the next 10 years. It will be the era of the Space Shuttle, which will raise our capability plateau to a much higher level due to the increased payload size and weight offered us by this vehicle. . . .

" . . .we will find uses to fill this capacity in the 1980's. . . .

" . . .space is becoming all-pervasive to civilian and military activities. . . ."

Dr. Currie's evident interest in and support of DOD's participation in the Space Shuttle program was characteristic of DOD/DDR&E's position regarding this program to date.

In his presentation to the Sub-committee on Space Science and Applications of the Committee on Science and Technology, U.S. House of Representatives, the Honorable Walter R. LaBerge, Assistant Secretary of the Air Force for Research and Development stated on 19 February 1976:

. . ."Mr. Chairman and members of the committee, I am very pleased to appear before you to discuss the Air Force space programs which are associated with NASA development efforts. The DOD and NASA continue to coordinate their activities through a series of committees which I described during my testimony last year. One of these committees, the Space

Transportation System Committee, is the main coordinating and planning committee for the Space Shuttle and is co-chaired by Mr. Yardley, NASA Associate Administrator for Space Flight, and myself. This committee will increase its activities this year, as the DOD Space Shuttle program accelerates to keep pace with the progress of the NASA development of the Space Transportation System (STS).

"This system, being developed by NASA, consists of the Space Shuttle, the Space Tug, and associated ground support systems. The Air Force, as the executive agent for the Department of Defense, has the responsibility to assure that DOD requirements are incorporated into the design of the STS. As the NASA Space Tug will not be available until post-1986, the Air Force has committed to the development of an Interim Upper Stage (IUS) vehicle to boost critical DOD payloads into high energy orbits from the lower altitude Space Shuttle orbits. This stage will be made available to all other users. NASA has been and will continue participating in source selection and development activities. NASA will also participate in the IUS requirements and design reviews to ensure that the IUS design will satisfy non-DOD operational requirements. Interface information such as the physical and functional Shuttle specifications as well as NASA ground processing, flight operations and mission control planning information will be provided to the DOD as required for the initial IUS development activities. The Air Force also plans to acquire a Shuttle launch and recovery site at Vandenberg Air Force Base, California, to allow DOD and NASA payloads to be launched into polar orbits which are not possible from the Kennedy Space Center due to technical and safety constraints. . . ."

The remarks of these gentlemen present an accurate word picture of the status of the Space Transportation System (STS) program at this writing.

This paper will attempt to provide a review and management analysis of the space operations problems facing the DOD/USAF and the NASA in the post-1980 STS era. Considerable effort will be placed on program history and acquainting the reader with the magnitude of the STS program. The approach to resolution of STS operations problems mainly in the areas of future scheduling and mission priorities will attempt to offer maximum inter-agency cooperation in DOD mission accomplishment with the NASA in this national program.

## SECTION II

### HISTORY OF THE STS PROGRAM

In the manned space flight programs accomplished by the NASA to date, DOD participation has been primarily supportive. For example, provision and management of TITAN boosters for the GEMINI program; ATLAS boosters for the MERCURY program; provision of helicopter emergency rescue capability for emergency recovery of astronauts during launch phase; all these were typical of the military role. DOD participation in the Space Shuttle program is considerably different<sup>2</sup>, since DOD had committed to use the NASA-developed Space Shuttle from inception.

In his address to the 21st annual meeting of the American Astronautical Society on the 26th of August 1975, Brigadier General Henry B. Stelling, HQ USAF Director of Space stated:

. . . "It gives me great pleasure to appear before you to discuss the Department of Defense's role in the development of the NASA Space Shuttle and our plans for participating in the operation of the Space Transportation system.

"General James Brickel represented the DOD on the President's 1969 Space Task Group which recommended that the shuttle be developed. When the President in 1972 announced his decision to authorize the development of the shuttle he described the shuttle's potential benefits of a manned and reusable launch system which would replace all but the smallest and largest expendable booster vehicles. In short, he envisioned a national system to make space even more attractive as an operating medium to all users.

"The DOD has had a continuing interest in investigating the utility of military man in space. However the expense of systems designed for this purpose alone has limited our opportunities to gain space experience. The opportunity to participate with NASA in acquiring a space transportation system is an opportunity to satisfy unique objectives of both agencies and at the same time provide a national capability which can be utilized by military, civil, and international users. It is an ambitious project, with a very large price tag, and one which may not be easily evaluated in traditional cost-benefit terms. Unlike NASA, who does have a separate space mission, the DOD looks at space as a fourth medium for accomplishing traditional military objectives, with primary emphasis on the support missions of communications, navigation, meteorology, and surveillance.

"Let me just say a few words on how we see the future of space systems within the DOD. The major role of military space systems in the next decade--the shuttle decade--will be to support national decision-makers and terrestrial military forces. There are four basic reasons for using space systems for various military support functions: (1) uniqueness--some functions essentially can only be done from space; like near real time warning of a ballistic missile attack; (2) economics--some functions are more cheaply done from space, like long haul communications; (3) function effectiveness--some functions are more effectively done from space, like meteorology, and (4) force effectiveness enhancement--some space functions can greatly enhance the effectiveness of terrestrial forces. The first three have been dominant until now; in the late 1970's and thereafter, the fourth will become increasingly important.

"U.S. and Soviet use of and dependence on space is growing; in a decade,

space systems will support virtually all military forces and could strongly influence the likelihood and outcome of conflicts. By the mid-1980's, U.S. military space systems will be crucial to national security". . . .

At present, the military mission in space includes the deployment and operation of space satellites for support missions of communications, navigation, meteorology and surveillance. DOD's current practice of satellite launches to low inclinations from Kennedy Space Center, Patrick AFB, Florida, and high inclinations from Vandenberg AFB, California, using limited-capability expendable launch vehicles (ELV's) up to the TITAN III class must of necessity continue until the STS is thoroughly phased in as the true national system. A guaranteed launch capability will be required from these existing expendable launch vehicles until the STS is fully operational.

In general terms, the NASA is providing the low-altitude, low inclination portion of the STS in that they are responsible for developing the Space Shuttle orbiter.<sup>3</sup> The orbiter carries space payloads from earth to approximately 100 nautical miles altitude. All design reference missions are inserted to a circularized 100 nautical mile orbit. At USAF's suggestion, both agencies are baselining use of the NASA Mission Control Center (MCC) at Johnson Space Center, Houston, Texas, for control of the orbiter portion of the STS flights. NASA is also providing the Kennedy Space Center (KSC) as a permanent launch/landing base for the STS, with initial operational capability (IOC) expected in mid-1980.

As we have discussed, USAF is providing the high-altitude, high-inclination portions of the STS in that the IUS will be made available

concurrent with the NASA orbiter IOC (1980) and Vandenberg AFB (VAFB) will be provided as a launch/landing site in FY 1983.<sup>4</sup>

NASA recognition of the difficulties of the transition of DOD space programs to the STS has resulted in inter-agency discussions and NASA offers to significantly lower the launch costs actually paid by DOD/USAF STS payload program users. This launch-cost reduction is made possible by the NASA recognizing the hardware, facilities, and development costs expended by USAF in funding their portions of the STS program through IOC of the Vandenberg site.<sup>5</sup> The 5-year Defense Plan (FYDP) budget updated by the DOD Program Objectives Memoranda (POM) in July 1976 for FY 1977 to FY 1981 included approximately \$1.2B of DOD/USAF funding to the STS. Nasa funding, estimated from program inception to achievement of full operational capability at Kennedy Space Center is approximately six times this amount. Minimization of the cost risks associated with transitioning existing DOD satellite programs to the STS and planning for future STS operations are the subject of significant DDR&E, HQ USAF, and Air Force Systems Command current efforts.

A break from the traditional management patterns developed by the STS program participants during the evolving space age begun by the USSR "SPUTNIK" satellite in 1957 provides significant opportunity for improvement in efficiency. This break from the traditional is apparent when one observes the management aspects of STS mission operations, and will be developed further by this report. The reader will observe that, counter to the normal tendency of any bureaucracy to stratify internal operations and atrophy external communications, the USAF and NASA have developed,

largely since STS program inception, formal and informal means of communication to enforce a "team" approach to STS management.

The evolution of this team approach<sup>6</sup> will be discussed further, and in conclusion a rationale and proposal for centralized STS mission operation management will be developed. A joint-agency mission operations planning and control function would be implemented with maximum benefits to both agencies. No existing study yet recommends looking at the future of the STS in greater than joint-agency terms; most studies presently are concentrating on the program office/mission control center operative levels of program development. A secondary purpose of this discussion, then, is to propose program operations development above the level of either participating agency in the hope of stimulating other approaches or eventual resolution of existing questions on this matter.

STS program background is reviewed with emphasis on DOD management direction to date and an overview of evolving roles and responsibilities at the management interface between agencies. The mission operations tasks are reviewed to present historical data and reader understanding of the functions required to support current space operation, and finally an approach to an "STS Operations Authority" for scheduling, planning, and operating future STS missions is proposed.

Unique to the STS is the European development of yet another portion of the NASA space shuttle program, the SPACELAB. Currently in full-scale development phase, the spacelab represents a foreign-nation development cost of not less than \$260 million dollars (FY 1975 \$) for a man-rated

pressurized laboratory to fit into the space shuttle payload bay. Designed to use electric power and support services from the orbiter itself, the Spacelab remains attached to the orbiter at all times, although its physical orientation in the payload bay may be changed due to its modular design.<sup>7</sup> The Spacelab is scheduled to reach IOC at Kennedy Space Center a few months after the orbiter is declared operational there. While DOD/USAF have not as yet confirmed any intent to use Spacelab for its missions, the reader is urged to keep the international political implications of this vehicle in mind. At present, the European consortium involved in developing Spacelab is 53.3% West German, 18% Italian, 10% French, 6.3% United Kingdom and the remaining 12.3% cost participation distributed geographically outside the USSR satellite nations.

NASA was highly successful in completing the APOLLO-SOYUZ space rendezvous mission on 15-24 July 1975, thus setting a precedent for US and USSR cooperation in space operations. It is expected that the USSR will formally request participation in the space shuttle program, and may offer astronaut crew members for international missions.

At the DOD STS Program Review held for the DSARC principals 18 December 1975, and chaired by Dr. Currie, ODDR&E restated clearly the view that the STS represented an advanced concept for necessary future operations, and in addition, Dr. Currie desired to preserve an option for escaping the increasing costs of remaining on today's expendable launch vehicles, since ELV's were experiencing rapidly rising costs of operation and lacked any significant growth potential. Despite this realization, costing issues remain difficult to resolve, i.e., provision of adequate "back-up" ELV'

during STS transition may cost USAF several hundreds of millions of dollars.

On 21 April 1976, the General Accounting Office (GAO) issued a formal report entitled "Status and Issues Relating to the Space Transportation System."<sup>8</sup> This GAO critique brings an essentially new factor in program assessment to our attention - namely, that the STS be made to justify its investment costs on the basis of benefits to be obtained and which are known and can be reliably estimated at this time. No previous space program has been asked to meet this requirement. The key to its successful resolution is the ability to quantify the benefits to be gained, provided the GAO position is accepted as a constraint at this time.

At the December 1975 Program Review, the OSD (Comptroller) independent cost-assessment group found that USAF had been very cautious in estimating STS program benefits, and were considered too conservative in estimating these benefits. As a result of these comments, the USAF is re-studying future benefits and attempting to quantify them as part of its FY 1977 programmed effort.<sup>9</sup> Despite the OSD Comptroller's comments, the STS program was expected to return its investment in the 12 years of operation (1980-1991) depicted in present DOD mission models by a combination of reduced launch and support costs compared with current ELV operations.

One additional important fiscal issue remains at this writing; this is the issue of who funds orbiters number four and five.

NASA budgeted to build the first three orbiter vehicles and bring them to operational status, but both USAF and NASA agreed at STS committee meetings that five (5) orbiters are required for a viable program to adequately

support the expected mission traffic growth. The NASA had expected DOD/USAF to fund the two additional orbiters, but the Deputy Secretary of Defense in a Program Decision Memorandum (PDM) of August 1974 directed USAF not to budget for any orbiters.<sup>10</sup> Also, at that time, Dr. Currie's staff at DDR&E informed the Air Force that in DOD's view, NASA was expected to provide the overall orbiter fleet. DOD was essentially merely buying space in the orbiter payload bay to have their payloads flown to specified deployment points in space.

The NASA recognized immediately that USAF could not afford to increase their STS budget to include two orbiters (estimated cost \$1.2 billion) and elected to petition the Office of Management Budget (OMB) to have these additional orbiters funded to NASA from government budget sources outside DOD/USAF. This activity, still in progress, is expected to result in an issue paper placed before the President by December 1976. The issue paper will be signed by DOD/USAF, NASA, and OMB.<sup>11</sup>

All other portions of the STS program are continuing as discussed. In August 1976, USAF selected the Boeing Aerospace Corporation to begin the validation phase of development on the Interim Upper Stage (IUS). On 22 September 1976, the NASA and Rockwell International Space Division held the ceremonial "rollout" of the first orbiter vehicle at Palmdale, California. This is orbiter number 101, the actual orbiter vehicle to be used in horizontal flight test at Edwards AFB, California, beginning in the summer of 1977.<sup>12</sup>

### SECTION III

#### DOD/USAF/NASA INTERAGENCY INTERFACES

In the fall of 1969, LtGen Samuel C. Phillips, NASA Project Apollo program director, returned to the USAF and took command of the Space and Missile System Organization, SAMS0, at Los Angeles AF Station, California. In his change-of-command address, General Phillips strongly endorsed the Space Shuttle program, and tasked his Development Plans Division (SAMS0/XR) to begin planning activities leading to full participation in this national program. In the early summer of 1970, a special program-office cadre was formed for STS, coded SAMS0/XRZ, and including the addition of several rated field-grade officers returning to USAF from the Apollo program. The program-office cadre immediately formed small program-office divisions at those NASA centers active in the shuttle program. Each "detachment" was commanded by a LtCol, and had four additional officer slots each. The NASA centers were Johnson Space Center (JSC), Houston, Texas; Marshall Space Flight Center (MSFC), Huntsville, Alabama; and the Kennedy Space Center (KSC) Cape Canaveral, Florida.

At that time, the NASA was in Phase A program initiation studies for the orbiter design, and soon issued a request for proposals (rfp) to industry for this space vehicle. USAF was invited to participate in contractor selection, and did so. Subsequent to selection of Rockwell International Corporation as the prime orbiter contractor, USAF routinely participated in contractor selection for other portions of the program. These included the external tank (ET), solid-rocket booster (SRB), and space shuttle main engine (SSME).

In Phase B (design phase), NASA elected to concentrate MSFC participation on the SRB and ET, so USAF participation then at that center was reduced, while participation at JSC and KSC was increased. JSC was designated as "lead center" for orbiter development and KSD "lead center" for launch operations by NASA top management.

Figure III-1 shows the relationship between agencies developed during this time period. At the headquarters level, the Air Staff was tasked by the Secretary of the Air Force to interface formally with NASA headquarters on the STS program, and elected to do so at the DCS/Research and Development level through the Director of Space, AF/RDS. The Director developed a charter for a joint-agency Space Transportation System (STS) Committee to be co-chaired by the Assistant Secretary of the Air Force for Research and Development (SAF/RD) and the NASA Associate Administrator for Manned Space Flight (NASA/OMSF)<sup>1,3</sup>. As a first action, the embryo STS committee agreed on 17 February 1970 that the proposed STS would be of maximum benefit to both NASA and the DOD.

On 30 March 1971, the Secretary of the Air Force testified to the House Committee on Aeronautical and Space Sciences as follows:

". . .to properly use an operational shuttle, the Air Force will have to reorient its approach to payload design, mission operations and launch vehicle improvement. . . .

". . .as stated earlier, we plan to replace our expendable launch vehicles with the reusable shuttle when it becomes operational. However,

# STS MANAGEMENT STRUCTURE

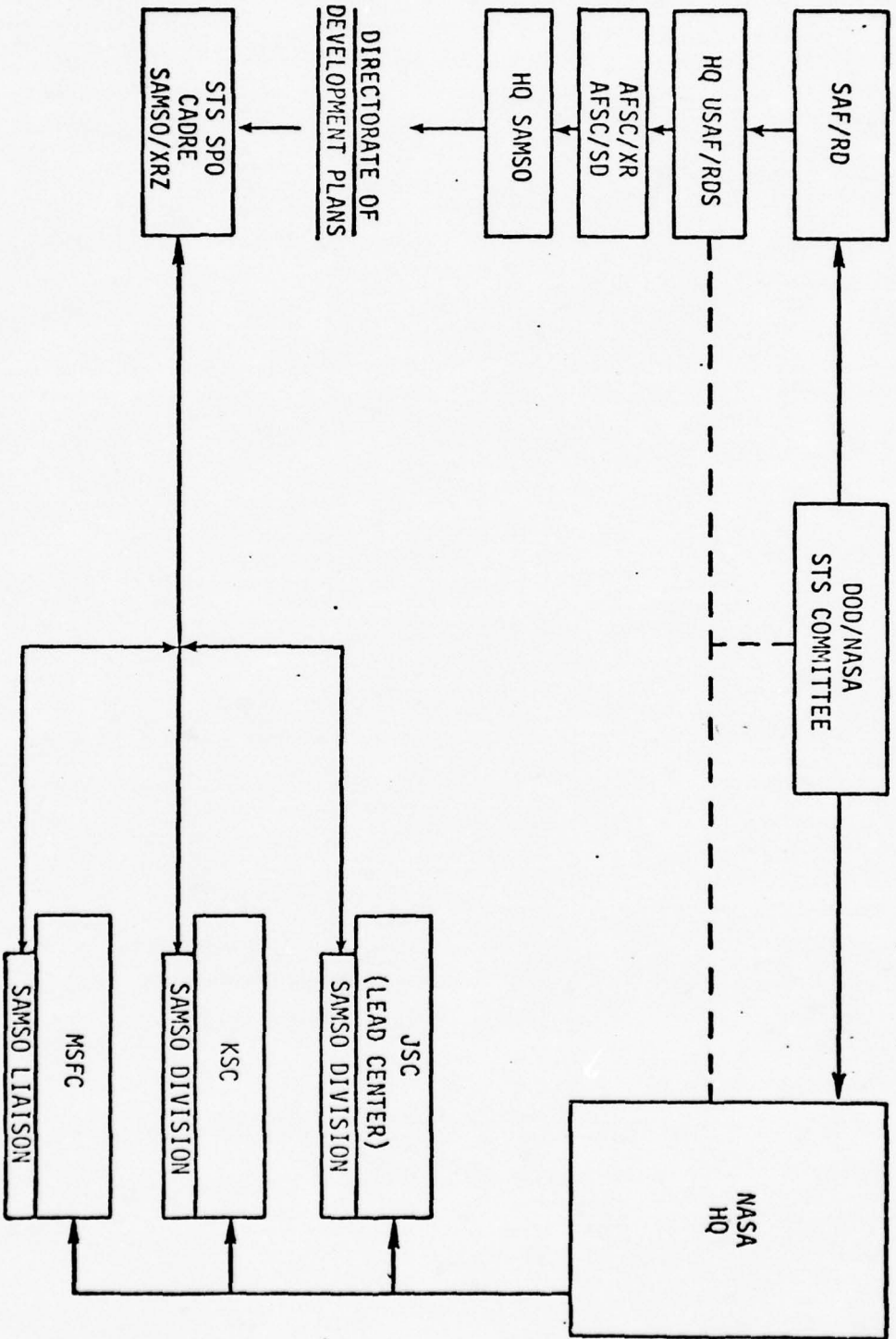

FIG. III-1

changeover must be accomplished without disturbing military mission capability and at minimum program cost. . . ."

In April 1972, DDR&E concurred for DOD in the selection of KSC and VAFB as launch and landing sites for Space Shuttle, and in May, ODDR&E further directed USAF to expand its working relationships with NASA in the shuttle program. In November 1972, the Deputy Secretary of Defense directed the military secretaries, the Chairman of the Joint Chiefs of Staff, and ODDR&E what actions should be taken in the planning for use of the space shuttle.<sup>14</sup> At the time of this action, a DOD STS User's Committee was formed to include membership from the Army, the Navy, the JCS, other interested persons, and at least one NASA observer.<sup>15</sup> The purpose of the USER Committee was to generate and guide DOD STS requirements definition and utilization studies. The USER Committee was chaired by the USAF Director of Space, and a formal charter was signed 2 November 1973 by the Deputy Secretary of Defense after concurrence by all participating parties.

In December 1973, ODDR&E informed Senator McIntyre, Chairman of the Research and Development Subcommittee of the Senate Armed Services Committee that USAF would develop the Interim Upper Stage for the Space Shuttle.<sup>16</sup> Concurrently, an "ad hoc" Upper Stage Panel of the STS Committee was formed to coordinate joint-agency needs in development of this vehicle. Co-chairman of the panel were the USAF Director of Space and the NASA Director of the Office of Advanced Mission Development at NASA headquarters.

In January 1974, the SAMSO program office was expanded considerably in size and reorganized under the Deputy for Launch Vehicles (SAMSO/LV)

with the title "Reusable Launch Vehicle" office; SAMSO/LVR. The management benefits gained in placing planning for transition to the STS under the same manager responsible for phase-down of the ELV's seemed prudent to the Commander of SAMSO; additionally, the functional staff personnel already available in SAMSO/LV could augment these tasks without immediate need for large numbers of additional personnel.<sup>17</sup>

In April 1974, USAF presented a Program Review on STS utilization to the DSARC principals. The USAF budget estimates were challenged, since development of parameters for operational costing and planning for the operational phase were considered incomplete; additionally, USAF was directed to remove any consideration of funding orbiter vehicles, as noted earlier in this paper. SAF/RD had requested in March 1974 that the STS Committee reconsider, and if necessary reaccomplish, the operations studies for Vandenberg AFB with intent to lower the initial DOD dollar commitment to critical operations, and to do so even if the "transition period" wherein certain DOD/USAF payloads remained on ELV boosters had to be lengthened. The results of this effort were reported to the STS Committee in December 1974 and the Aeronautics and Astronautics Coordinating Board (AACB) in January 1975.<sup>18</sup> The AACB is co-chaired by ODDR&E and the NASA Deputy Administrator, and coordinates joint-agency programs at the policy level, see Fig.III-2.

To aid these efforts, a permanent Operations Steering Committee under the STS Committee, co-chaired by the USAF Director of Space and the NASA Deputy Associate Administrator for Manned Spaceflight was formed in the summer of 1974. That fall, the Undersecretary of the Air Force elected to form a temporary advisory panel, the Defense Science Board Task Force on

# STS MANAGEMENT STRUCTURE

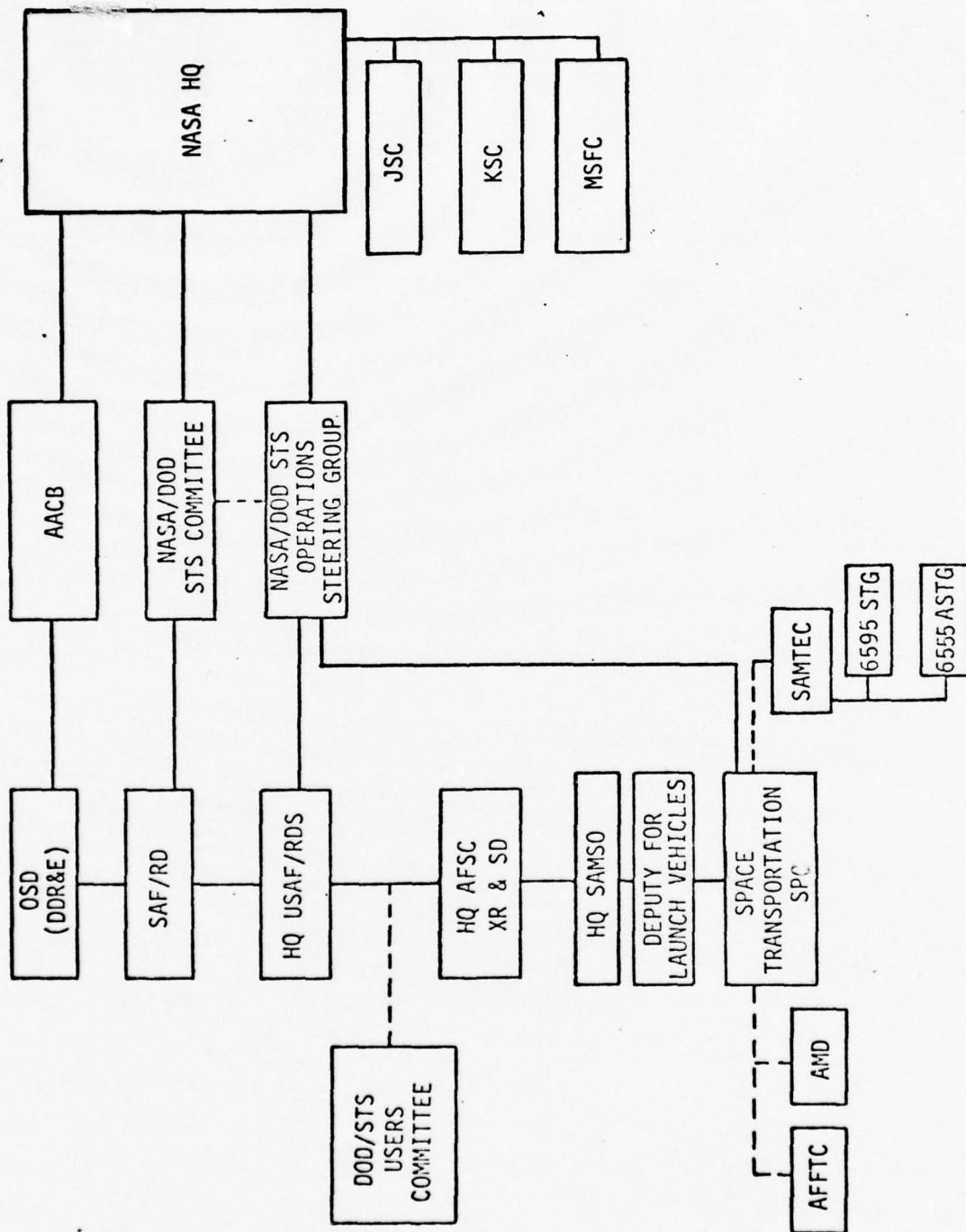

FIG. III-2

DOD Shuttle Utilization at the request of ODDR&E to consider the STS transition problem that existing DOD payloads would encounter with an eye to using this experience to develop future operational STS concepts. Serving without pay, this group met approximately quarterly for 15 months, and issued a short final report in the winter of 1975. The group strongly recommended that the SAMS0 Commander consider convening an advisory panel of this nature on a permanent basis at his management level to give periodic evaluation to the progress of STS operational concepts.<sup>19</sup> The task force concurred in the recommendation that the JSC/MCC be used for low-altitude (orbiter) portions of all STS missions, but that the AFSCF also be evaluated for this role should it prove necessary.

During the fall of 1975, pre-Program Review Briefing and discussion sessions were held in the Pentagon. During this time period, SAF/RD recognized that the myriad headquarters-level joint-agency proliferation of panels, committees, and DOD-level required reviews could be detrimental to efficient communications between the NASA and USAF operational levels. Accordingly, the USAF Director of Space advised Air Force Systems Command of the desirability of the USAF Program Manager (SPO Director) being able to meet directly with the NASA Associate Administrator for Manned Spaceflight on operations issues not involving determination of policy or funding. In January 1976, the STS SPO Director began a series of permanent bi-monthly meetings with the NASA/OMSF designed to resolve operations issues. Appendix E contains the minutes of this first meeting, and are representative of this continuing effort.

SECTION IV

STS Operations Issues

On 12 February 1975, the Undersecretary of the Air Force forwarded a memorandum to the Director of Space on the subject of Shuttle Payload Interfaces.<sup>29</sup> This memorandum summarized certain recommendations of the Defense Science Board Task Force on DOD Shuttle Utilization on the subject of shuttle payload interfaces; as follows:

" . . . a. The orbiter should monitor payload telemetry points which affect the safety of man only.

b. Commands to the payloads should be limited to safing the payload in event of an abort.

c. No payload check-out is necessary prior to release. The rationale for this position is based on the fact that mission program personnel at the ground stations are required to monitor and analyze telemetry anomalies prior to any corrective action. The decision-making capability is and should be ground-based.

d. The orbiter should be required to stand-by, and station-keep at a safe distance after release of the payload while the payload is checked out. The payload checkout should be performed through existing Air Force mission support networks and control centers. If a problem is detected, the orbiter may be asked to assist in resolving the problem and possibly retrieve the payload for return.

e. The Orbiter/payload interface should be kept simple to minimize costs. This includes minimizing the impact of DOD security requirements whenever possible. . . ."

These recommendations summarized verbal discussions held between the DOD payload programs and the STS program office at SAMSO, but did not match either the DOD studies or the NASA mission operations baseline for the space shuttle program at that time. In addition, separate discussions between the AF Undersecretary and the NASA deputy administrator at this time underscored the necessity of NASA recognition of the use of the mission control center at JSC for control of the orbiter portion of all STS flights, regardless of launch point. USAF plans clearly reflect expected use of the AF Satellite Control Facility (AFSCF) at Sunnyvale, California, for the IUS high-altitude portions of the STS missions. NASA, with USAF concurrence, planned to control the IUS when used for NASA missions from JSC in a manner similar to previous NASA mission experience.

Appendix B contains extracts from the draft DOD annex to the Space Shuttle Baseline Operations Plan, and is included to expand on the following summation.

The current DOD Space Operations area is characterized by:

1. Exclusive use of unmanned mission vehicles and satellite payloads.
2. Operations from both Eastern Test Range, KSC and Patrick AFB, Florida, for low-inclination missions and the Western Test Range, VAFB, California, to high-inclination missions; all use USAF personnel for range safety functions and responsibility.
3. Mission Control from AFSCF regardless of launch point.
4. Payload satellites already in production or initial hardware phases to meet ELV design interface requirements; most will experience high modification costs to transition to STS.

5. Classified mission objectives.

Conversely, the NASA mission operations task areas are currently characterized by:

1. Commitment to the use of manned mission vehicles in that most future missions are space-shuttle dependent.
2. Operations from KSC contemplate elimination of the need for DOD/USAF range safety constraints.
3. Mission control from JSC/MCC regardless of launch point.
4. Design of all future civil payloads to meet shuttle design constraints; no large backlog of ELV-compatible payloads exists.
5. Completely unclassified mission objectives.

Earlier in this paper, it was pointed out that NASA agreement to allow the orbiter to perform the "postman" role of placing a DOD payload at a given deployment point in space was largely dependent on a resolution of the JSC/MCC security issues. For this reason, the outline of an on-going joint-agency study of this problem area is presented (see Appendix C) since it states the pertinent problem areas clearly and concisely.

## SECTION V

### CONSIDERING THE FUTURE: A RECOMMENDATION

Dr. Currie's remarks to the PMC 76-2 students indicate clearly that he considers the space shuttle a national resource, one that will surely develop many uses for DOD in the 1980's.

It has been discussed how, with the establishment of appropriate inter-agency management interfaces at various agency levels, the co-chairman of the STS Committee and other DOD and NASA officials took actions at appropriate times to assure that STS problem areas with particular regard to STS operations could be resolved.

In addition, it was pointed out that some inter-agency steps have been taken by the NASA Administrator, the DOD, and the Director of the Office of Management and Budget to attempt to resolve the matter of how space shuttle orbiters four and five will be funded. This issue will be raised to the Presidential level in the Executive Branch by December of this year.

A question must be raised: how can the future space transportation system, made possible by the advent of the space shuttle, be made more responsive to future operational national priorities above the authority level of either the USAF or the NASA?

Figure V-1 depicts an approach to development of a joint DOD/NASA operations authority which can be made directly responsive to national command authority on a routine operating basis: The figure is explained and supported by presentation of appropriate rationale.

In the proposed organization, a joint DOD/NASA operations authority (JOA), reporting to the NCA at the Vice-President level and limited to mission priority/operations scheduling functions would be formed with a small staff of hand-picked personnel of equal numbers from both agencies<sup>21</sup>

Composition of the JOA would be the subject of a special study tasked to both agencies through the Vice-President beginning in late 1977 and be of approximately 1 year duration. The results of the study could then be implemented by the accomplishment of STS initial operational capability at Kennedy Space Center in the summer of 1980.<sup>22</sup>

# JOINT DOD / NASA PLANNING CONCEPT

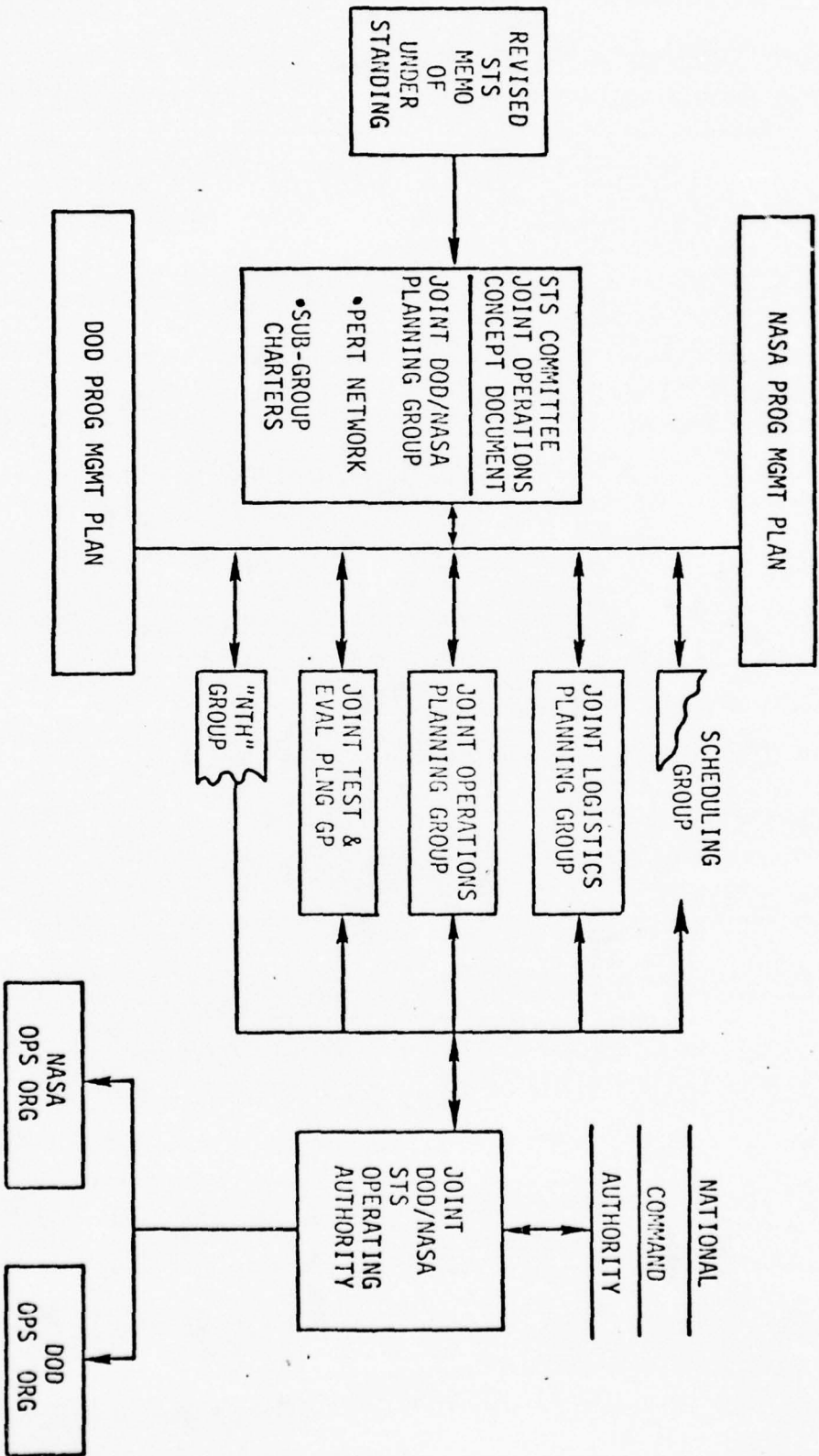

FIG. V-1

FIGURE V-1 Rationale

The figure shows the proposed "future" joint-agency STS Operations Authority deriving its logical input/output requirements from planning groups co-chaired by representatives from each agency. The Program Management Plans of each agency are developed to recognize a revised STS Memorandum of Understanding (MOU), which generates a joint-agency STS Operations Concept Document agreed to by the co-chairmen of the STS Committee, and interfacing with a joint-agency Planning Group.

The proposed STS Operations Authority is responsive to national command authority, and directs the operations organizations of each agency through their respective command channels.

## SECTION VI

### SUMMARY

This paper has attempted to present the evolution of a vast national research and technology undertaking, the Space Transportation System (STS) in terms of its impact on the interfaces, agreements, and functions of the two major participating Federal agencies. The National Aeronautics and Space Administration and the Department of Defense stand on the brink of a new space era. This era is made possible by the NASA-developed space shuttle orbiter, the USAF-developed upper stage, the supporting communications networks and launch bases of both agencies and the payloads or satellites placed accurately in space by this new system.

All these components must be combined to make up the STS, no component will function effectively without the others. Similarly, the management decisions, adjustments, and compromises necessary for two fiscal giants of the size of these agencies has been depicted. The STS will reflect an expenditure of not less than 10 billion in fiscal year 1975 dollars as the USAF launch site activation program at Vandenberg AFB reaches initial operational capability. Of this sum, approximately 17% will have been expended by the DOD/USAF, with NASA expending the remainder, or \$8.3 billion. As the STS operational phase evolves, it is expected that these cost ratios will shift even as the cost of routine space operations is significantly lessened by this system. The advantages of rapid, routine access to space coupled with greatly increased payload weight and volume will generate mission payloads yet unknown.

## NOTES

1. Guest Lecturer; Hon. Malcolm Currie, ODDR&E, OSD; Defense Systems Management College; 21 Sept 1976; video tape no. 76-2-23A,B.
2. Letter to the Vice President of the United States from the Office of the Secretary, Department of the Air Force, 4 August 1969. Untitled.
3. Agreement between the NASA and the Department of the Air Force concerning the Space Transportation System, 17 Feb 1970, amended 2 Aug 1972.
4. Letter from Dr. John S. Foster, ODDR&E to the Administrator of NASA, Dr. James C. Fletcher, 13 April 1972. (This document gives DOD concurrence in the selection of KSC and VAFB as launch and landing site for the Space Shuttle.)
5. Memorandum, ODDR&E to Assistant Secretary of the Air Force (Research and Development); Subject: "Plan for NASA/DOD Orbiter Procurement Decision," 18 Feb 1976.
6. Memorandum to the Military Secretaries, Chairmen of the Joint Chiefs of Staff, and the DDR&E from the Office of the Deputy Secretary of Defense, 13 Nov 1972. (Directs planning actions for Space Shuttle; establishes DOD STS User Committee.)
7. Article, Astronautics and Aeronautics Magazine, Feb 1976 issue; "SpaceLab Shaping Space Operations Planning", Mssrs. Fred R. Steven, NASA/OSF and Christian Reinhold, European Space Agency (ESA).
8. Report to the Congress; "Status and Issues Relating to the Space Transportation System", Comptroller General of the United States, 21 April 1976.
9. IBID
10. "Program Decision Memorandum"; 31 August 1974; as pertains to Space Shuttle Program Element 63411F; signed by the Deputy Secretary of Defense Mr. William Clements, extract.
11. IBID
12. Department of Defense Space Transportation System "Program Management Plan"; USAF Space and Missile Systems Organization; Los Angeles AF

Station, California, 31 July 1975.

13. IBID
14. IBID
15. Letter from the Director of Space, DCS/R&D, HQ USAF; forwarding the DOD Space Shuttle User Committee Charter to all interested agencies, 26 Nov 1973.
16. Letter, ODDR&E to Chairman, R&D Subcommittee of the Senate Armed Services Committee, 21 Dec 1973.
17. Interview, LtCol Joel Rosenzweig, SAMSO/LVRU, DOD Interim Upper Stage Program Manager, 11 Sept 1976, reference validation phase (development) planning for his program.
18. Interview; Mr. William Moore, GS-15, NASA HQ/Code MKT; Secretary, STS Committee; 11 September 1976.
19. Memoranda, Undersecretary of the Air Force to Director of Space/AFRDS; 12 Feb 1975; Subject: "Shuttle Payload Interface".
20. IBID
21. Memoranda; NASA Associate Administrator for Space Flight to SAMSO Commander and NASA Space Shuttle Program Directors; Subject: "STS Operations Management Committee", 7 April 1976.
22. Interview; COL Morgan W. Sanborn, USAF, Division Chief, HQ USAF/AFRDSA; Directorate of Space, DCS/RD, 16 Oct 1976.

## BIBLIOGRAPHY

1. Address; "Department of Defense and the Shuttle," BrigGen Henry B. Stelling; HQ USAF, Director of Space to 21st Annual Meeting of the American Astronautical Society; 26 August 1975.
2. Article; "Spacelab Shaping Space Operations Planning"; Mssrs. Fred Steven, NASA, and Christian Reinhold, ESA; Astronautics and Aeronautics, February 1976 issue.
3. Article; "USAF, Boeing Completing Shuttle IUS Negotiations"; Aviation Wk. & Space Tech., 16 Aug 1976, pp.23.
4. Article; "Shuttle Orbiter Completed on Time," Aviation Wk. & Space Tech., 20 Sept 1976; pps. 12-14.
5. Article; "Space Shuttle Orbiter 101 Rolled Out," Aviation Wk. & Space Tech., 27 Sept 1976; pps 12-16.
6. Article; "The Space Shuttle - High Flying Yankee Ingenuity," Edgar Ulsamer; Air Force Magazine; September 1976, pp 98.
7. Astronaut Fact Sheet; NASA Public Relations Release No. 76-16; February 1976 (NASA HQs)
8. Briefing, NASA -S-75-6135 "Presentation on DOD Concerns," 17 Oct 1975; NASA Johnson Space Center (JSC); Houston, Texas.
9. Briefing, "Status of DOD/STS Satellite Mixing/Flight Sharing; 19 May 1976; working papers to support mission models regarding orbiter purchase issue as tasked by AACB in January 1976. NASA/SAMSO.
10. Collins, Michael; "Carrying the Fire"; New York; Farrar, Strons & Giroux, 1974.
11. Drennan, R.M. & Heinlein, W.H., Majors, USAF; "Proposals for U.S. Military Space Missions in the Late 20th and Early 21st Centuries," Air Command and Staff College; May 1975.
12. HQ USAF Program Management Directive for Space Shuttle; Department of the Air Force; AFRDSA, 30 June 1975 (as amended by TWX in FY 76).
13. DOD Space Transportation System Program Management Plan; USAF; Space and Missile Systems Organization, (SAMSO); Los Angeles AF Station, California, 31 July 1975.
14. DOD Space Shuttle System Summary, USAF, Reusable Launch Vehicle System Program Office, Deputy for Launch Vehicles, SAMSO, Los Angeles, Calif., 15 Aug 1975.

15. Memorandum, "DOD Space Transportation System Operations Concept," 10 December 1976; SAMSO/LV to selected distribution.
16. Memorandum of Understanding, "Management and Operation of the Space Transportation System," NASA Assoc. Admin. for Manned Space Flight, 10 March 1975, and USAF Asst. Secretary for Research and Development, 16 April 1975.
17. Memorandum, "Plan for NASA/DOD Orbiter Procurement Decision," ODDR&E to SAF/RD; 18 Feb 1976.
18. Memorandum; "Interim Upper Stage (IUS) DSARC Milestones," SAF/RD to ODDR&E, 1 March 1976.
19. Memorandum, "Defense Science Board Task Force Report on DOD Shuttle Utilization," HQ USAF/AFRDS to AFSC/SD, 10 March 1976.
20. Memorandum for Record, "Meeting with MajGen Henry on Shuttle," Mr. Howard Barfield, DDR&E/S&AS, 17 March 1976.
21. Memorandum, "Safety Requirements for Payloads Using the Space Transportation System," NASA Associate Administrator for Space Flight to Assoc. Admin. for Space Science, 24 March 1976.
22. Memorandum, "STS Operations Management Committee," NASA Assoc. Admin. for Space Flight to Selected Distribution, 7 April 1976.
23. Memorandum, General Accounting Organization Final Report; "Status and Issues Relating to the Space Transportation System; AF/ACUA to AF/RDXL; HQ USAF, 27 April 1976.
24. Memorandum, "TITAN III/Interim Upper Stage (IUS) Integration," AFSC/SD to HQ USAF/AFRDS; 21 May 1976.
25. Memorandum, "Ground Rules for Joint Study on Impact of Security at JSC for DOD Missions," NASA/JSC; Mr. Glynn S. Lunney to NASA HQ Director, STS Operations, 24 May 1976.
26. Memorandum, "JSC Security Requirements," SAMSO/LV to NASA/JSC (Code PA), 1 June 1976. (COL Thomas M. Sumner, SPO Director to Mr. Glynn Lunney.)
27. Joint Memorandum, "Draft of the Department of Defense Annex to the Baseline Operations Plan." From NASA Director of Flight Operations, JSC and Assistant Program Director, STS Program Office to special distribution, 10 June 1976.
28. Minutes, "STS Meeting Between SAMSO and OSF, 15 January 1976," with enclosures; R.M. Lovelace, Exec. Asst. to Dep. Assoc. Admin. for Space Flight, 20 Jan 76 (NASA HQ).

29. Position Paper, "STS Military Construction Program Packaging," HQ USAF/AFPPEPA; working paper; Maj R. Holecomb, 14 June 1976.
30. Presentation to the Subcommittee on Space Science and Applications, Committee on Science and Technology, United States House of Representatives; Subject: "FY 1977 NASA Activities" by the Honorable Walter B. LaBerge, Assistant Secretary of the Air Force/ Research and Development, 19 Feb 76.
31. Special Announcement; "Establishment of the Office of Planning and Program Integration," NASA Administrator, 23 January 1976.
32. Interview, Lt Col Frank Paporozzi, HQ USAF/AFRDSA, 10 Aug 1976, reference his role as Executive Secretary, Defense Science Board Task Force on DOD Shuttle Utilization.
33. Interview, COL J.A. Saavedra, USAF at NASA HQ, 26 August 1976, reference his role as Study Manager on Space Shuttle orbiter procurement and related issues; review of Statement of Work draft for OMB review dated June 1976.
34. Interview, Mr. William Moore, GS-15, at NASA HQ, 11 September 1976, reference his role as NASA Secretary of the STS Committee 1971-1976 inclusive, discussion of relevant committee actions; review of minutes.
35. Interview; COL Morgan W. Sanborn, HQ USAF/AFRDSA, reference the progress of certain ODDR&E directives and post-program Review agreements on the STS program; review of progress of orbiter Buy issues on joint-agency studies; 19 September, 16 October 1976.

APPENDICES

- A:**     NASA/DOD Space Shuttle Program  
          Annex I. . .NASA/DOD Memorandum of Understanding  
          Annex II . .Space Shuttle System Definition
- B:**     STS Operations Concepts  
          Extracts of DOD Annex to NASA Johnson Space Center  
          (JSC) Baseline Operations Plan
- C:**     JSC Mission Control Center (MCC) Security Study  
          Extracts of Ground Rules; Study Plan
- D:**     Minutes SAMSO/OSF Meeting; 15 January 1976

APPENDIX A: NASA/DOD Space Shuttle Program

Annex I NASA/DOD Memorandum of Understanding

Annex II Space Shuttle System Definition

NASA/DOD  
MEMORANDUM OF UNDERSTANDING  
ON  
MANAGEMENT AND OPERATION  
OF  
THE SPACE TRANSPORTATION SYSTEM

1.0 PURPOSE: This Memorandum of Understanding establishes the broad policies and principles that will govern the relationships between the DOD and NASA relevant to the development, acquisition and operation of the national Space Transportation System. The Memorandum of Understanding shall be used as the basis for more detailed documentation between the NASA and the DOD further delineating Space Transportation System management and operations concepts and the specific roles and responsibilities of each agency.

For purposes of this Memorandum of Understanding, the national Space Transportation System consists of an earth-to-orbit Space Shuttle, the upper stage(s) required for orbital velocities exceeding the Shuttle capability, and the ground support equipment and facilities necessary for operation of the system. A NASA-developed reusable full capability upper stage, called the Space Tug, is planned. Until the Space Tug becomes available, the DOD-acquired upper stage will be used by both agencies in the early years of the program. This will be called the Interim Upper Stage (IUS).

2.0 BACKGROUND: On February 13, 1969, the President appointed a multi-agency Space Task Group to develop recommendations on the direction which the U. S. Space Program should take in the post-Apollo period. The Space Task Group recommended that a reusable Space Transportation System be developed to allow more economical and effective use of space.

On February 17, 1970, NASA and the Air Force, acting as the designated agent for DOD, established by joint agreement the NASA/USAF Space Transportation System Committee to provide an instrumentality for joint review and recommendations concerning development and evolution of a Space Transportation System which can fulfill the objectives of both NASA and the DOD in a manner that best serves the national interest.

On January 5, 1972, the President decided that the United States should proceed at once with the development of a space transportation system capable of providing routine access to space and taking the place of all present launch vehicles except the very smallest and the very largest.

On April 13, 1972, the selection of J. F. Kennedy Space Center, Florida and Vandenberg Air Force Base, California, as launch/landing sites for the Space Shuttle was agreed upon.

3.0 GENERAL POLICIES AND PRINCIPLES: It is understood that the Space Shuttle is a NASA-developed program and that DOD will use this system. Effective and efficient use of the national Space Transportation System requires an environment of understanding and cooperation between the agencies. To this end, there shall be maintained a free and effective interchange of essential technical, financial, and managerial information between the two agencies. This interchange shall be accomplished primarily through the NASA/USAF Space Transportation System Committee. Coordination will be maintained with the Aeronautics and Astronautics Coordinating Board and other joint groups established by mutual agreement.

It is anticipated that interest in the National Space Transportation System will continue to grow as more and more agencies recognize the merits and benefits associated with a non-expendable means for placing and retrieving payloads in space. The STS should provide benefits for many varied space requirements. Fulfillment of requirements from actual and potential users of this system must be given careful consideration. Insofar as their fulfillment does not compromise other priority requirements to an unreasonable degree, they will be accommodated.

The cooperation and coordination required will be implemented so as to assure consistency with applicable policy with respect to the relationship between civil and military space activities.

4.0 MANAGEMENT AND OPERATIONS CONCEPTS: The overall objective is to ensure that the national Space Transportation System will be of maximum utility to both agencies. The accomplishment of this objective will be under the purview of the joint NASA/USAF STS Committee.

The following concepts, policies, and principles, and the associated roles and responsibilities are agreed to:

4.1 NASA RESPONSIBILITIES

4.1.1 The NASA is responsible for the development of the Space Shuttle, to include the orbiter and its propulsion systems, the solid rocket boosters, the external tank and the general purpose ground support equipment and facilities.

4.1.2 The NASA will make every effort to incorporate the DOD requirements into the Space Shuttle, with due consideration for schedule and cost impacts, in order that the STS be designed and developed to fulfill the objectives of future uses of the STS.

4.1.3 The NASA is responsible for providing the general purpose Shuttle equipment and facilities to perform the ground, launch and landing activities for all Space Shuttle operations at the Kennedy Space Center (KSC). NASA will plan for an initial operational capability at KSC in 1980.

4.1.4 The NASA is responsible for providing to DOD those requirements affecting the Interim Upper Stage (IUS) design which are considered important to meet NASA objectives.

Tug and plan for an initial operational capability in the mid 1980's. It is planned that the Space Tug will provide for payload retrieval or on-orbit servicing of high orbit payloads to fully meet the needs of STS users.

4.1.5 The NASA will plan to use the limited capability Interim Upper Stage (IUS) as the primary upper stage pending the availability of a Space Tug.

4.1.6 The NASA is the responsible agency for flight planning and integrating all flights and users involving NASA programs, commercial enterprises, non-military U. S. Government agencies, and non-military international activities. NASA will provide for management, integration, flight operations and control for all flights for which it is the responsible agency regardless of launch or landing site used. Payload mission planning is the responsibility of the payload agency.

4.2 DOD RESPONSIBILITIES: The DOD will plan to use the STS as the primary vehicle for placing payloads in orbit. In addition:

4.2.1 The DOD is responsible for providing to NASA those requirements affecting the Space Shuttle System design which are considered essential to meet the DOD objectives.

4.2.2 The DOD will develop the Interim Upper Stage (IUS), including the general purpose ground support equipment, to permit early utilization of the Shuttle during the DOD payload transition period pending planned development of the Space Tug by NASA. The DOD will insure that both DOD

and NASA requirements are considered in the five contracted Interim Upper Stage (IUS) studies which constitute the conceptual phase. The DOD will determine the cost and schedule impacts of incorporating the NASA requirements into the IUS. Final configuration and funding responsibilities will be the subject of later negotiations between NASA and DOD.

4.2.3 The USAF is the responsible agency for planning and integrating all missions and users, involving DOD programs and international military activities covered by government-to-government agreements. The USAF will provide for management, integration, mission operations and control for all payloads for which it is the responsible agency regardless of launch or landing site used.

4.2.4 The USAF is responsible for providing the general purpose Shuttle equipment and facilities to perform the ground, launch and landing activities for all Space Shuttle operations at Vandenberg Air Force Base (VAFB). The USAF will plan for an initial operational capability at VAFB in 1982.

#### 4.3 OTHER RESPONSIBILITIES

4.3.1 The resources of both agencies which can contribute to the development, test, production, training and operations for the STS will be used to the maximum extent possible. Plans and agreements on agency roles and responsibilities for use of these resources will be developed as required.

4.3.2 Studies will be continued to evaluate in-depth approaches to STS operations. These studies will consider a single agency operation as an alternative to the dual agency operation. The studies will include ground operations, launch operations, flight operations, mission control operations, landing operations and refurbishment responsibilities. Options for suitable choice of an operations concept and operations agency will continue to be reviewed.

4.3.3 To the maximum extent possible, ground support equipment and ground operating procedures developed for use at Kennedy Space Center by NASA will be used by DOD at Vandenberg Air Force Base. NASA will consider the DOD operational needs at Vandenberg Air Force Base in the development of KSC equipment and procedures.

4.3.4 Each agency is responsible for providing its own payload facilities, other peculiar facilities and peculiar GSE. Mutual usage of facilities will be considered where feasible and appropriate.

4.3.5 Joint studies will be undertaken to explore the use of the Mission Control Center (MCC) at the Johnson Space Center (JSC) for Space Shuttle flight control until Vandenberg Air Force Base reaches IOC.

4.3.6 STS flight elements procured will be interchangeable for use on either agencies missions, and capable of being operated at all designated sites.

4.3.7 Joint plans and agreements will be developed for training and providing crews to meet mission requirements.

4.3.8 A procurement strategy for acquisition of STS production items will be jointly developed by NASA and the USAF for both initial investment and continuing procurement.

4.3.9 The STS will be compatible with the communications, command, and control systems of both agencies.

4.3.10 An operating/using agency(ies) mission model, to include expendable booster transition and phase-out plans, will be maintained to provide the basis for program and operational analyses and planning.

4.3.11 This Memorandum of Understanding represents the current status of agreements between NASA and the DOD on development, acquisition and operation of the Space Transportation System. Revisions and/or amendments will be made as required to maintain the currency of this document.

5.0 EFFECTIVE DATE: This Memorandum of Understanding is effective on the latest date of the signatures below:

*John F. Yardley*

John F. Yardley .  
Associate Administrator  
for Manned Space Flight

Date: March 10, 1975

*Walter B. LaBerge*

Walter B. LaBerge  
Assistant Secretary of the  
Air Force (Research and  
Development)

Date: 16 APR 1975

APPROVED:

\_\_\_\_\_  
James C. Fletcher  
Administrator  
National Aeronautics and  
Space Administration

Date: \_\_\_\_\_

\_\_\_\_\_  
William P. Clements, Jr.  
Deputy Secretary of Defense

Date: \_\_\_\_\_

## ANNEX II

### SPACE SHUTTLE SYSTEM DEFINITION

#### 1.0 INTRODUCTION

This annex describes the major physical, performance, and interface characteristics of the Space Shuttle system currently being developed by the NASA. The definition presented herein is a condensation of the material given in the DOD Space Shuttle System Summary, Reference 1, and represents the best information available at this time. This information is believed to be in concert with the NASA Level I and DOD Shuttle Systems Requirements, References 2 and 3, respectively, and the NASA Space Shuttle Level II Program Definition and Requirements, References 4 and 5.

It should be recognized that the Space Shuttle is still in the evolving phase of design definition and its characteristics are subject to change with time. Accordingly, the Shuttle system definition given herein will be revised and updated as more definitive information becomes available.

#### 2.0 SHUTTLE SYSTEM DESCRIPTION

##### 2.1 SPACE SHUTTLE SYSTEM

The Space Shuttle system consists of a reusable, manned orbiter, expendable External Tank (ET), and two recoverable, unmanned Solid Rocket Boosters (SRB) integrated as shown in Figure II-1. The Orbiter carries the crew and payload and is mounted "piggyback" to the single, expendable tank which contains all of the hydrogen and oxygen propellants utilized by the Orbiter rocket engines during the ascent phase of flight. The two solid rockets that comprise the booster are located under the wings of the Orbiter and are attached directly to the propellant tank. Dimensions of the

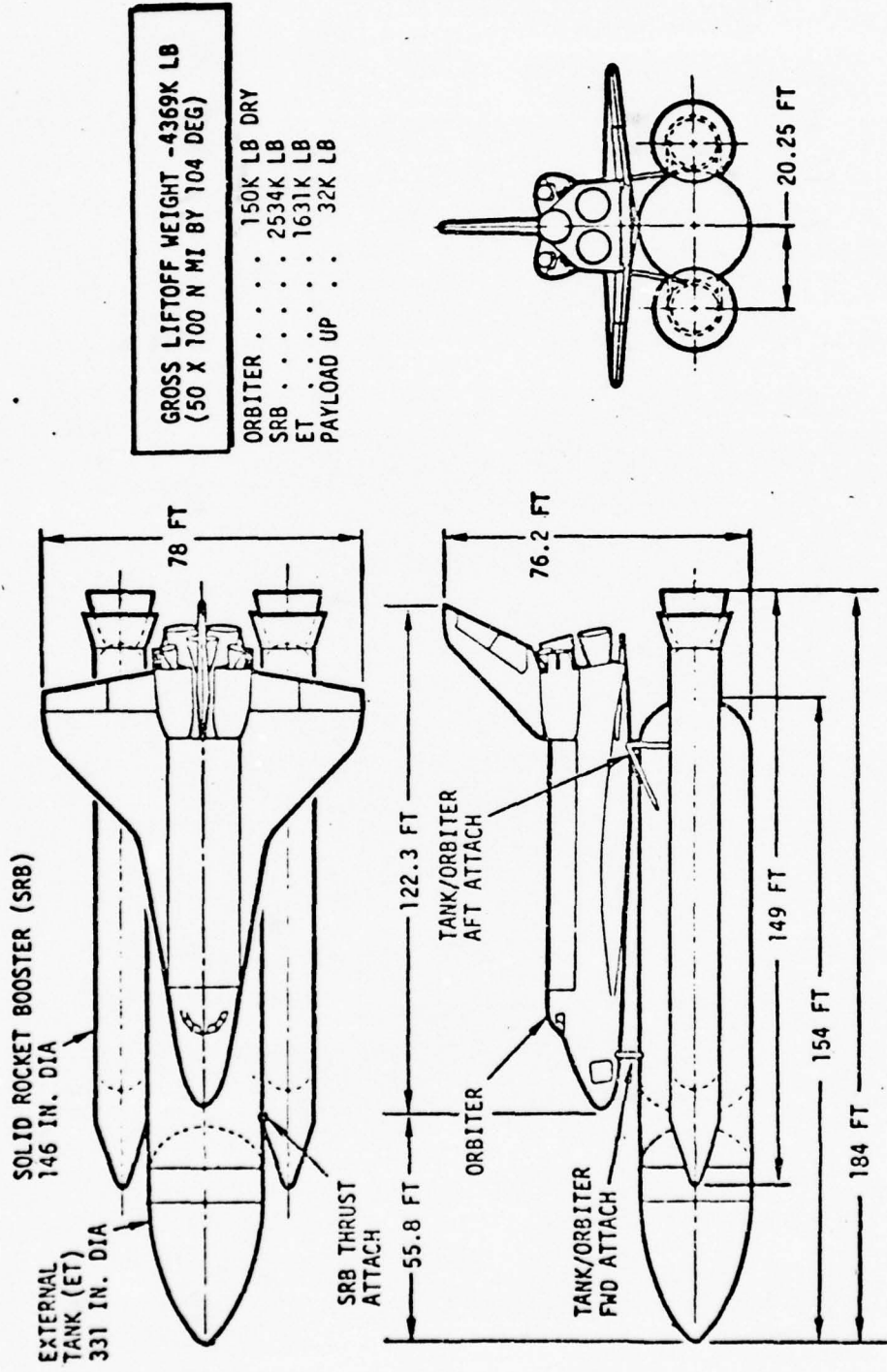

Figure II-1. The Space Shuttle Vehicle

vehicles are shown in Figure II-1. Gross weight at liftoff is about 4.37 million lb.

Liftoff thrust is provided by parallel burning of the Solid Rocket Motor (SRM) and Orbiter three main engines giving a launch thrust-to-weight ratio of 1.5. Guidance and control through the boost phase is provided by Orbiter main engine thrust vector control (TVC), SRM TVC, and rudder deflection. At SRB staging, auxiliary rockets are fired to accelerate the expended cases from the vehicle. The SRM cases follow a ballistic trajectory after separation, are decelerated by parachute, and are recovered after water landing. The three Orbiter main engines continue firing to bring the Orbiter to near orbital velocity. The orbital maneuvering subsystem (OMS) provides the propulsive thrust to perform orbit insertion, circularization, orbit transfer, rendezvous, and deorbit. The reaction control subsystem (RCS) provides vehicle attitude control in space and translation capability for small velocity increments.

The Shuttle system is autonomous in that it can be independent of ground control for such operations as: state vector calculation; normal subsystems management; consumables management; burn computations; vehicle executive authority; etc. The flight vehicle is dependent on the ground for such operations as: navigation RF sources (OWD, TACAN, MSBLS) remote tracking, station pass service; mission executive authority; emergency support of subsystems management; trajectory modifications; reprogramming of consumables; etc.

The Solid Rocket Booster (SRB) is used to augment ascent propulsive thrust up to a staging velocity of about 4,700 ft/sec. The primary elements are the rocket case, nozzle, propellant system, igniter with safe and arm provisions, aft skirt and launch support, separation motors, and nose fairing and recovery subsystem. Each SRB contains polybutadiene acrylonitrile (PBAN) propellant, weighs about 1.27 million lb and produces 2.65 million lb of thrust at sea level. The propellant grain is shaped to reduce thrust at approximately 45 seconds after liftoff to prevent overstressing the

vehicle. The grain is of conventional design, employing a star perforation in the forward motor closure and a truncated cone perforation in each of the segments and in the aft closure. The SRB has a vacuum specific impulse of about 266 sec and a gimballed nozzle with an omni-axial capability of 8 degrees.

The external tank illustrated in Figure II-1 contains all of the liquid hydrogen ( $LH_2$ ) and liquid oxygen ( $LO_2$ ) propellants supplied to the Orbiter main engines. All fluid controls and valves for operation of the main propulsion system (MPS) are located in the Orbiter to minimize throwaway costs. Five lines (three fuel and two oxidizer) interface between the external tank and the Orbiter. All interface lines except the oxidizer vent line are insulated with spray-on foam and protected with a fiberglass fairing. An uninsulated antigeysers line on the external tank provides  $LO_2$  geyser suppression. Liquid level point sensors are used in both tanks for loading control.

The external tank contains 1.55 million lb of propellant at lift-off. The liquid hydrogen tank volume is 53,800  $ft^3$ , and the liquid oxygen tank volume is 19,500  $ft^3$ . These volumes include a 3-percent ullage provision. The hydrogen and oxygen tanks are pressurized to respective ranges of 32 to 34 psia and 20 to 22 psia. Both propellant tanks are constructed of aluminum alloy skins with support or stability frames as required. The aluminum skirt structures use integral machine-milled skin-stringers with stabilizing frames. The structural attachment to the Orbiter consists of one forward and two rear connections through truss structures mounted to the  $LH_2$  tank support frames and longerons.

## 2.2 ORBITER VEHICLE AND SUBSYSTEMS

The Orbiter is a reusable, manned, delta-wing spacecraft with size and shape as illustrated in Figure II-2. The pressurized crew compartment, payload bay, support subsystems, attitude control and orbital maneuvering systems and the main propulsion system are all contained in the fuselage. Payloads of up to 65,000 lb are carried in the cargo bay, which is 15 ft in diameter and 60 ft in length. The vehicle is comparable in size and weight to a modern jet transport. It has a dry weight of approximately 150,000 lb,

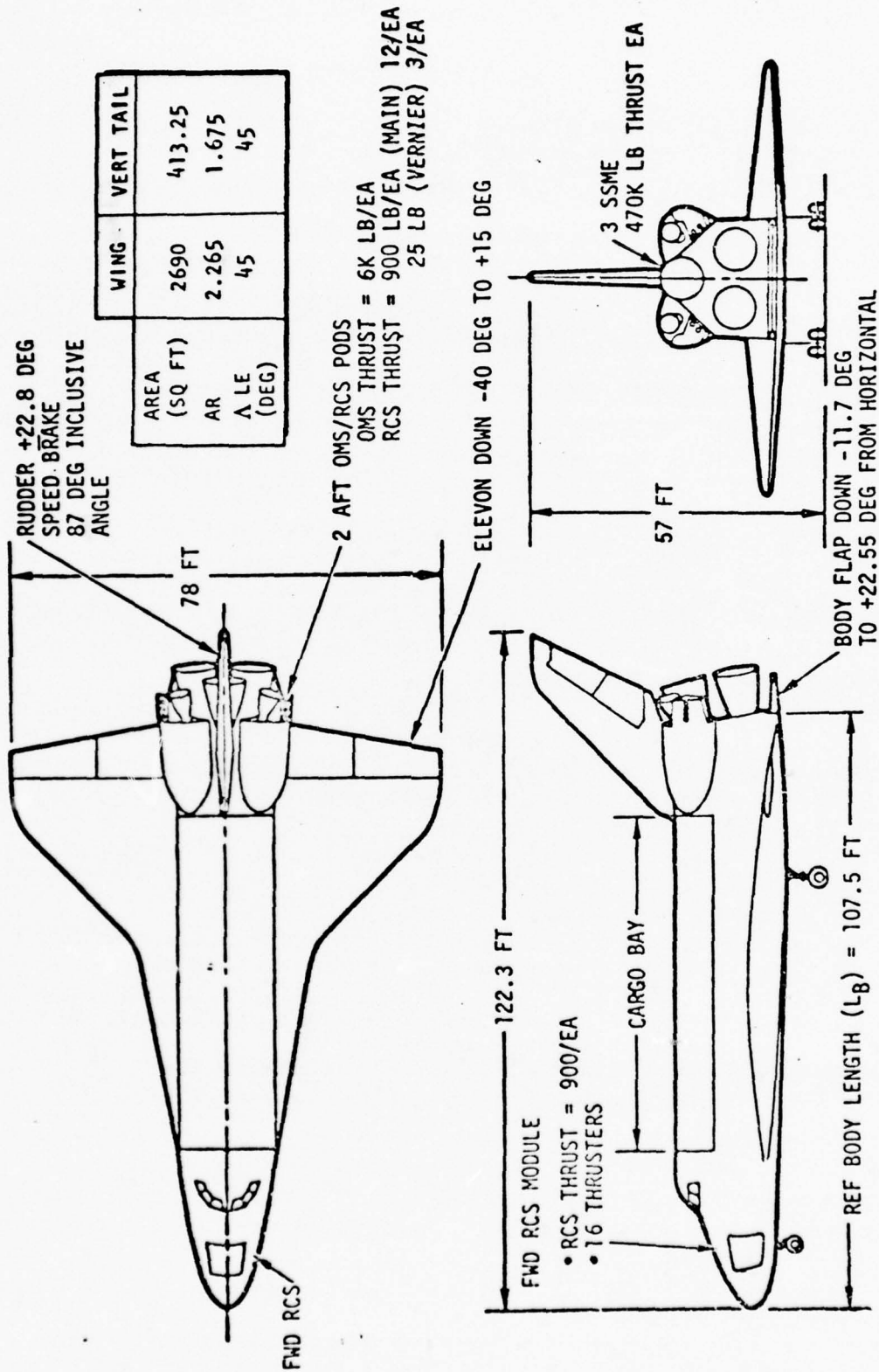

Figure II-2. Shuttle Orbiter

an overall length of about 122 ft, and a wingspan of 76 ft. The aerodynamic shape features a  $45^{\circ}/87^{\circ}$  double-delta wing platform sized to provide 165 knots design landing speed. Flight control from entry (400,000 ft) is achieved by the combined use of elevons and yaw reaction control motors. The orbiter vehicle is trimmed to provide a hypersonic lift-to-drag ratio of about 1.3 during entry and about 4.6 at subsonic speeds.

Crew and passengers are accommodated in a 2-level pressurized compartment with an airlock on the lower level (see Figure II-3). The flight station on the top level utilizes side-by-side seating and allows combined pilot operations. A shirtsleeve cabin environment is provided, and up to 3 additional personnel (7 men total crew and passengers) may be accommodated on the second level where the avionics bays are located. The environmental control and life support (ECLS) equipment, which is designed to accommodate a mission up to 42 man-days (expendables over 28 man-days charged to payload), is located beneath the lower deck floor. A galley and waste management/hygiene system are located on the lower deck.

The three Space Shuttle main engines (SSMEs), yielding 470,000 lb of vacuum thrust (ea) at an ISP of 455 seconds, are contained in the aft fuselage. Ascent propellant is contained in the external tank, which is jettisoned before initial orbit insertion. The orbital maneuvering subsystem (OMS) is contained in two external pods above the wing on the aft fuselage. These units provide thrust (6000 lb ea) for orbit insertion, changing orbit, rendezvous, and deorbit. The reaction control subsystem (RCS) is contained in the two OMS pods and in a module in the nose section of the forward fuselage. These 38 main (875 lb thrust ea) and 6 vernier (25 lb thrust ea) units provide for attitude control in space and precision velocity changes for rendezvous, docking or orbit modification.

As illustrated in Figure II-4, the majority of the Orbiter structure is of conventional aluminum construction protected by reusable surface insulation. The crew module is machined from 2219 aluminum alloy plate with integral stiffening stringers and internal framing. The assembly is

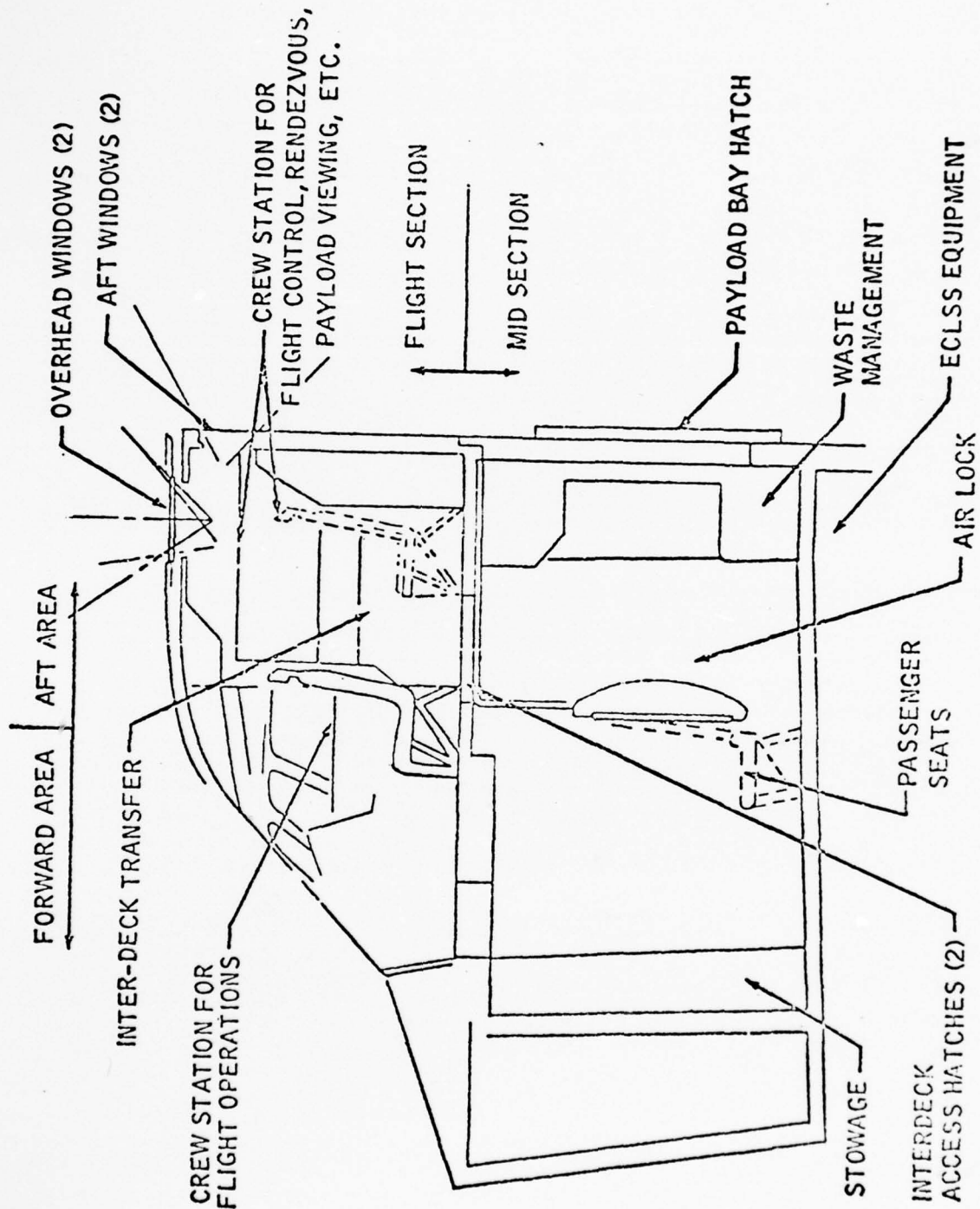

Figure II-3. Crew Compartment Concept

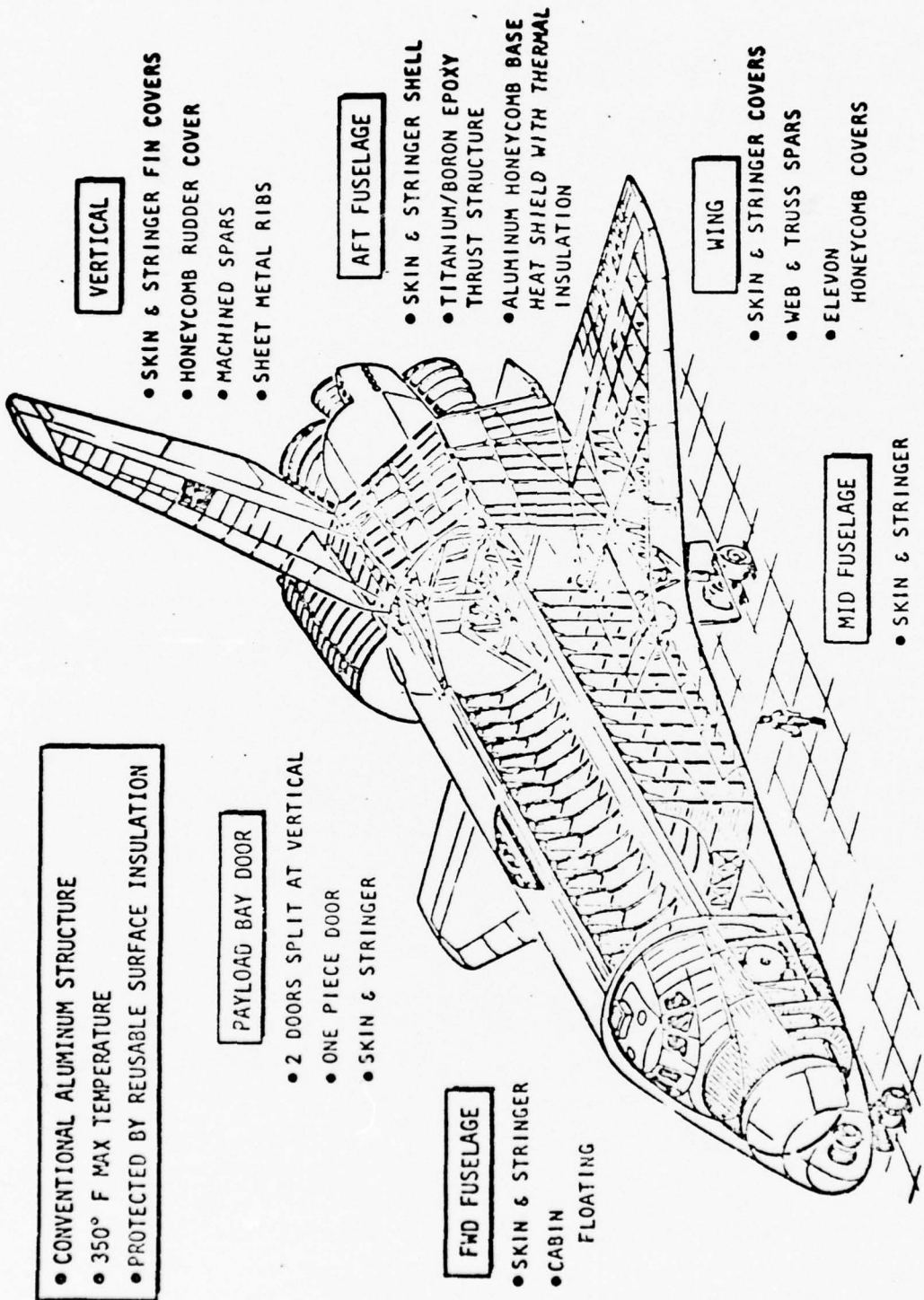

Figure II-4. Orbiter Structure Subsystem

welded to create a pressure-tight vessel. The module has a side hatch for normal ingress and egress, a hatch into the airlock from the mid-deck, and a hatch from the airlock into the payload bay for EVA and IVA. The entire module is supported by four attach points on the forward fuselage structure. The forward fuselage structure is composed of 2024 aluminum alloy skin/stringer panels, frames, and bulkheads. The window frames are machined parts attached to the structural panels and frames.

The mid-fuselage is a 61-foot section of primary load carrying structure between the forward and aft fuselages. It includes the wing carry-through structure and the payload bay liner. The skins and stringers are machined as integral aluminum panels. The frames are constructed as a combination of aluminum panels with riveted or machined integral stiffeners and a truss structure center section. The upper half of the mid-fuselage consists of structural payload bay doors, hinged along the side and split at the top centerline. Conventional skin-stringer frame construction is employed.

The aft fuselage includes a truss-type internal structure of diffusion-bonded elements that transfers the main engine thrust loads to the mid-fuselage and external tank. The external surface of the aft fuselage is of standard construction except for the removable orbital maneuvering subsystem (OMS) pods. A bulkhead heat shield at the rear of the vehicle provides protection to the main engine systems.

The thermal protection subsystem (TPS) consists of materials applied externally to the primary structural shell of the Orbiter vehicle and maintains the airframe outer skin within acceptable temperature limits, e. g. , 350 degrees Fahrenheit for aluminum structure. It is a passive system and neither the internal insulation and heaters nor any of the purging facilities are considered part of the subsystem. The TPS supports mission requirements, by having the following required subassemblies, maintain acceptable primary structure temperatures:

1. Low temperature reusable surface insulation (LRSI) and structural attachment components, including joints and interface to special function singularities, when exposed to temperatures below 1200°F under design heating conditions.
2. High temperature reusable surface insulation (HRSI) and structural attachment components, including joints and interfaces to special function singularities, when exposed to temperatures between 1200°F and 2300°F under design heating conditions.
3. Reinforced carbon-carbon (RCC) on areas such as leading edge, nose cap, chine, and structural attachments, along with internal insulation, when exposed to temperatures greater than 2300°F under design heating conditions.
4. Thermal window panes
5. Thermal seals, as required, to protect against aerodynamic heating.

The Orbiter mechanical subsystems (illustrated in Figure II-5) with electrical and hydraulic actuators, operate the aerodynamic control surfaces, landing/deceleration system, payload bay doors, and payload accommodation and payload handling subsystems. Orbiter/external tank propellants disconnects and a variety of other mechanical and pyrotechnic devices are also part of the mechanical subsystem.

Aerodynamic control surface operation is accomplished by single-balanced, dual switching servo actuators for the control of elevons, rudder, and speed brake. A 3000-psi hydraulic system supplies the power for these actuators. The landing/deceleration system and its mechanical components are designed to facilitate safe landing at velocities up to 221 knots. To meet these demands, 40,000-pound rated tires and special brakes ( $280 \times 10^6$

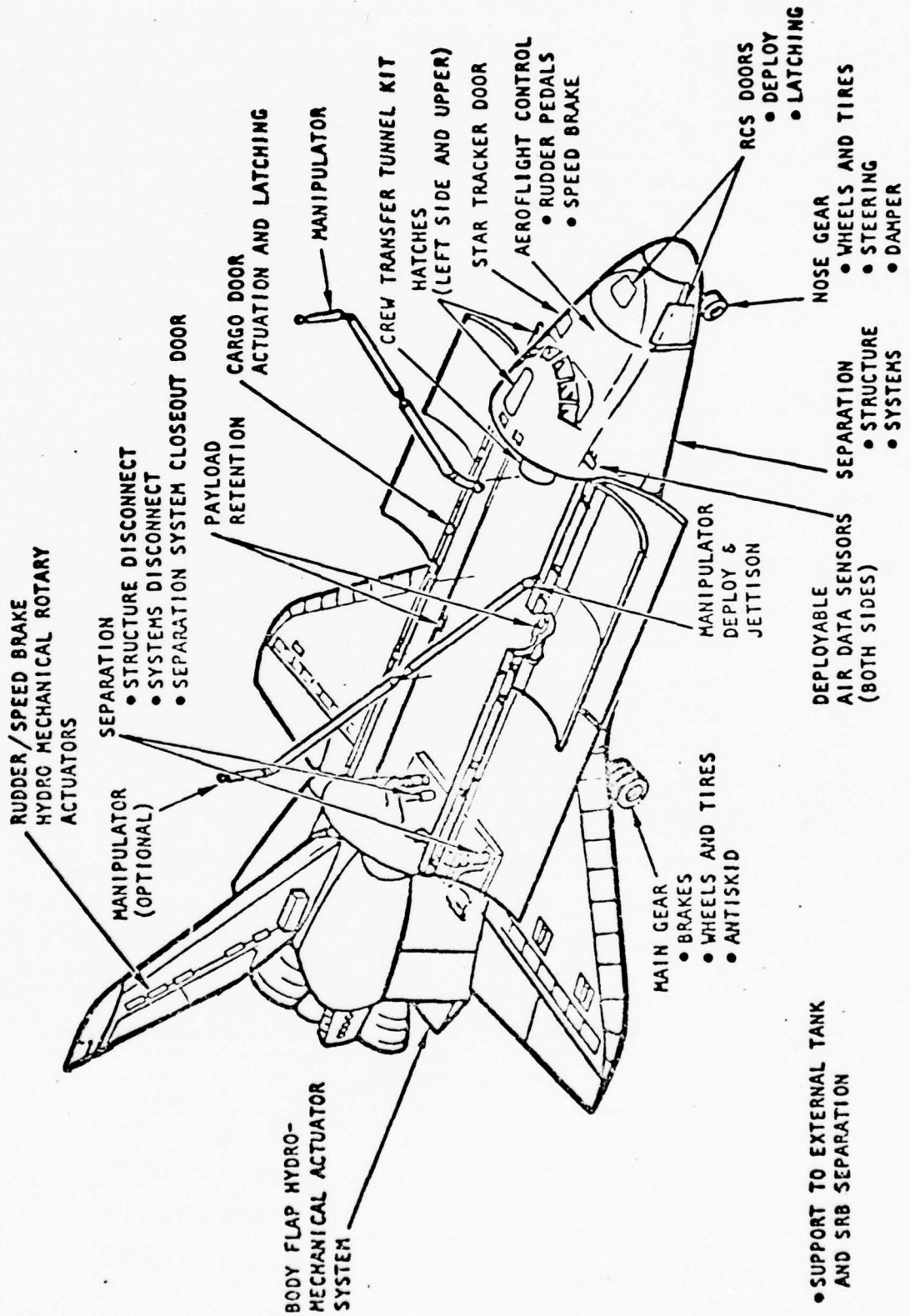

Figure II-5. Orbiter Mechanical Subsystems

foot-pounds) are under development.

The cargo bay doors, RCS doors, and separation-system close-out doors are operated by actuators that must provide predictable performance after severe environment exposure during ascent and entry. The payload accommodation subsystem includes remotely controlled retention latches that hold down or release the payload or cargo items. Their design is such that they cannot transmit Orbiter stresses, such as bending, to the payload. The payload handling subsystem consists primarily of remotely controlled manipulator arms (one arm normally installed, second arm optional) that can move the payloads out of and/or into the cargo bay while the Orbiter is in orbit.

The Orbiter avionics subsystem provides commands; guidance, navigation, and control; communications; computations, displays and controls; instrumentation and electrical power distribution and control for the Orbiter, the ET, and the SRBs. The Orbiter flight deck is the center of both in-flight and ground activities except during hazardous servicing. Major ground links during checkout are hard-line digital command data to the vehicle and PCM measurement data from the vehicle via hard-line and RF transmissions. Automatic vehicle flight control is provided for all mission phases except rendezvous and docking; manual control options are available at all times. A fail-operational/fail-safe capability is provided by a combination of hardware and software redundancy. Orbiter avionics interface with payloads is provided by means of hard-wired controls and displays when attached and RF links when detached. S-band communication links between the Orbiter and ground stations permit the Orbiter to transmit and receive data. Both S-band and Ku-band can be used for communication through the NASA Tracking and Data Relay Satellite (TDRS) System.

The avionics equipment is arranged, as shown in Figure II-6, to facilitate checkout and for easy access and replacement with minimal disturbance to other subsystems. Almost all electrical and electronic equipment is installed in three areas of the Orbiter: the flight deck, the forward avionics equipment bays, and the aft avionics equipment bays. Redundant subsystems

- GN&C
- C&T
- D&C
- ELECTRIC POWER DISTRIBUTION
- INSTRUMENTATION
- DPS

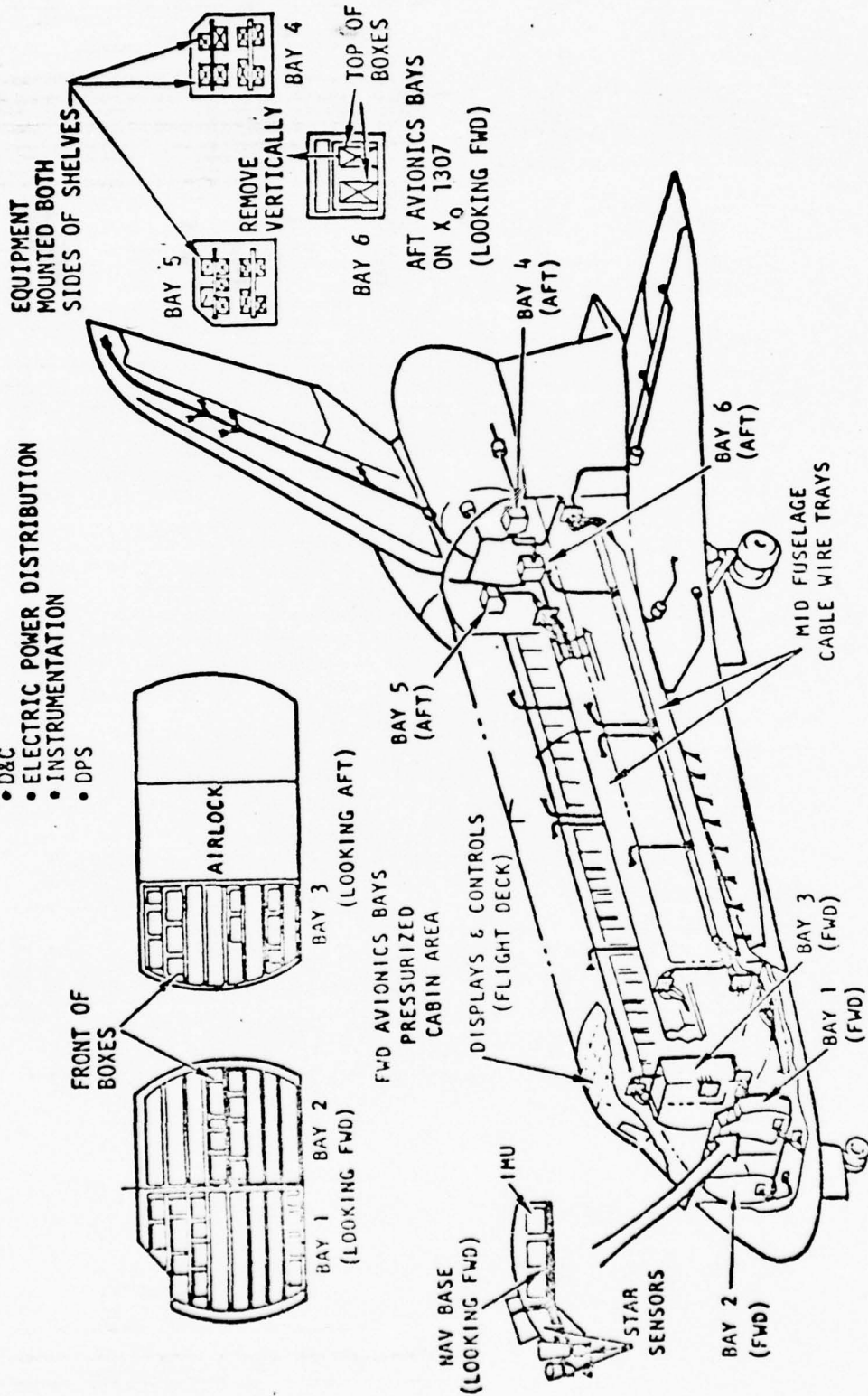

Figure II-6. Orbiter Avionics Installation

are installed in separate bays whenever possible. Cooling by both forced air and coldplate is available in the forward avionics equipment bays. All of the equipment in the unpressurized aft avionics bays is mounted on coldplates. Inertial Measurement Units (IMUs) on the navigation base are cooled by forced air convection. Exposed equipment (e.g., star sensors) is thermally protected by insulating material applied to exterior surfaces.

All antennas, except the dual usage rendezvous/TDRSS wide band, are flushed-mounted on the top, bottom and sides of the orbiter forward fuselage. Two S-band quad antennas for PM communication with ground stations and the NASA Tracking and Data Relay Satellites (TDRS) low bit rate are mounted on each side of the forward fuselage. One S-band FM antenna is mounted on both the top and bottom surfaces of the forward fuselage. Four C-band horns for the radar altimeter and a UHF antenna for Air Traffic Control (ATC) voice communication are also located on the underside of the forward fuselage. Three pairs (one each top and bottom) of L-band TACAN antennas supply three redundant onboard TACAN receivers. The top and bottom antennas provide coverage to both landing site and side TACAN transmitters during vehicle roll and pitch maneuvers. TACAN acquisition occurs above 130,000 feet. Three Ku-band microwave scan beam landing system (MSBLS) antennas are mounted in the upper surface of the orbiter nose. They provide precise azimuth angle, elevation angle, and range information with respect to the runway. Antenna radiation patterns allow acquisition at 14,000 feet (minimum).

A Ku-band rendezvous radar antenna, which is also used for TDRS Ku-band communications, is located in the Orbiter cargo bay.

### 3.0

#### SHUTTLE PERFORMANCE CHARACTERISTICS

In order to satisfy requirements of the missions projected for the Shuttle era, the Shuttle system is being designed to operate at orbital inclinations between 28.5 and 110 degrees and at orbital altitudes from 100 to more than 500 nautical miles. The weight of payload carried to orbit in the

Orbiter cargo bay can vary from zero to 65,000 lb, depending on the mission, while the payload returned from orbit can be as much as 32,000 lb for a nominal mission and up to 65,000 lb in an emergency. In most missions, the Shuttle will operate in a circular orbit; however, the vehicle does have the capability to deploy or retrieve its payload while in an elliptical orbit.

### 3.1 REFERENCE MISSIONS

A set of reference missions was developed to facilitate the generation of Space Shuttle design, performance, and operational requirements (see Chapter 2). The reference missions contain, between them, all the driving characteristics found in the projected mission model. A listing of the reference mission characteristics is given in Table II-1.

Reference Mission 1 typifies the characteristics of geosynchronous orbit placement mission. The maximum in SSV performance and mission duration is required. Reference Mission 2 is characteristic of the sortie missions in the STS Mission Model. This mission taxes the Shuttle on-orbit operating capabilities. It will not be described in this document because the DOD Mission Model does not contain resupply/sortie missions.

Reference Mission 3A is a one-revolution mission involving the release of a payload near apogee of an elliptical orbit. The requirements of this mission sized the SSV. The entire mission is time critical. Each operation must be done in sequence and in a very restricted time duration. This mission also uses the maximum aerodynamic crossrange capability of the Shuttle orbiter and maximum ascent performance.

Reference Mission 3B requires the single-earth-revolution retrieval of the payload placed in orbit by Mission 3A. This mission has the time criticality and maximum crossrange requirements of 3A, plus a rapid rendezvous and retrieval capability. The 2500-pound up payload allowance was established to account for the equipment that might be required to support and constrain the retrieved payload. Total weight of equipment returned to earth on this mission is 25,000 pounds.

TABLE II-1 SPACE SHUTTLE REFERENCE MISSIONS

MISSION	INCLINATION (DEG)	ASCENT PAYLOAD (K LB)	LAUNCH SITE	OMS ΔV <sup>(1)</sup> (FPS)	RCS ΔV <sup>(2)</sup> (FPS)
1. DUE EAST	28.5	65	KSC	650	100
2. RESUPPLY	55.0	MAX CAPABILITY <sup>(4)</sup>	KSC	1250	120
3A. DEPLOY	104.0	32	VAFB	250	100
3B. RETRIEVE <sup>(3)</sup>	104.0	2.5	VAFB	425	190

H-16

NOTES: (1) OMS ΔV IN EXCESS OF 50 X 100 N MI REFERENCE ORBIT REQUIREMENTS

(2) RCS FOR ORBITAL TRANSLATION MANEUVERS ONLY, ADDITIONAL RCS FOR ATTITUDE CONTROL ON-ORBIT AND ENTRY AS REQUIRED

(3) ACTUAL INSERTION CONDITION OPTIMIZED FOR MISSION (50 X 100 N MI REF. ORBIT NOT REQUIRED)

(4) MAXIMUM CAPABILITY ≈ 35.8K LB

INCLUDES ONCE-AROUND ABORT CAPABILITY FROM RTLS POINT

### 3.2

#### LAUNCH AZIMUTH CONSTRAINTS

In April 1972, the decision was made to establish two operational launch sites for the Space Shuttle Program. This decision was based upon projected DOD and NASA missions that require the capability to launch Space Shuttle payloads, without land mass overflight, into orbital inclinations ranging from 28.5 to 110 degrees. The two sites selected were Kennedy Space Center (KSC) for launches into low inclination orbits and Vandenberg AFB for launches into high inclination orbits. The overlap in orbital inclinations attainable from KSC (28.5 to 57 degrees) and from Vandenberg AFB (56 to 110 degrees) ensures that the required missions can be accomplished. DOD desires growth capability to 140-degree inclinations.

Range safety criteria limit available exit azimuths, as shown in Figure II-7. Shuttle launches from KSC are limited to between 35 and 120 degrees azimuth. The upper limit of this sector, equivalent to an inclination of 57 degrees, prevents the instantaneous impact point (IIP) trajectory of an accidentally released external tank from passing over the southeast portion of Newfoundland. The sector's southern limit is determined by the proximity of the IIP trace to the Bahama Islands. This limit corresponds to a launch inclination of 39 degrees south of east. Southeast launches from Vandenberg AFB are confined to exit azimuth greater than 140 degrees (equal to an inclination of 56 degrees). The IIP trajectory for launches at lower inclinations passes over portions of Mexico. The earth trace of the IIP for launches at inclinations above 140 degrees passes over the Hawaiian Islands. These launch azimuth constraints have been established for program-planning purposes. Actual launch azimuth constraints to be applied to operational flights are currently being evaluated by NASA and DOD.

In addition to evaluating the planar launch exit azimuth limits, shown in Figure II-7, studies are being conducted of the feasibility of planar launches southeast from KSC at an inclination of 63.4 degrees. Launch azimuth and overflight constraints for yaw steering (doglegging) maneuvers during Shuttle ascent are also under investigation.

KENNEDY SPACE CENTER

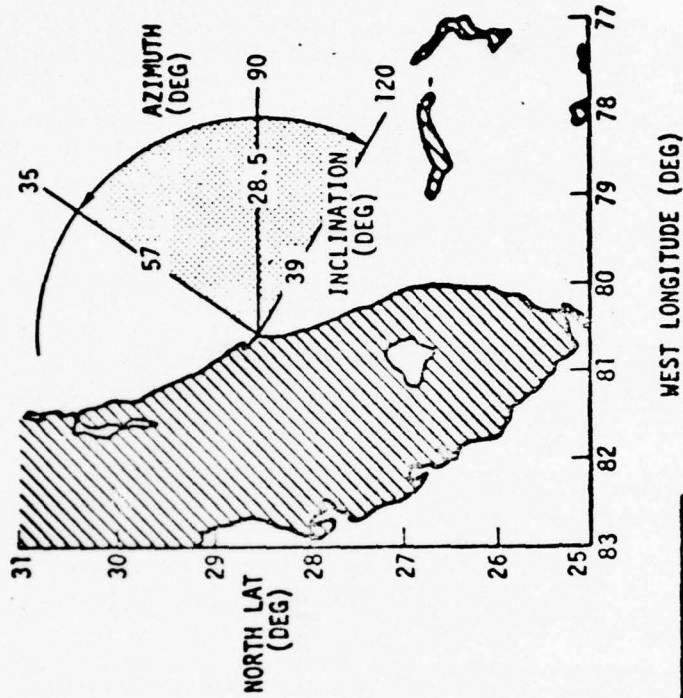

VANDENBERG AIR FORCE BASE

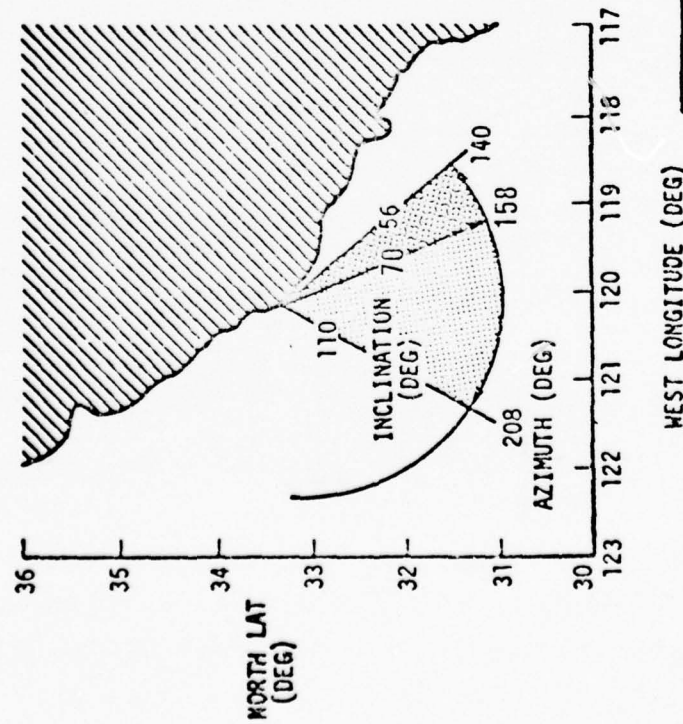

	ALLOWABLE
	CONDITIONAL

Figure II-7. Launch Azimuth and Inclination Limits

### 3.3 PERFORMANCE CAPABILITY

The performance capabilities of the Space Shuttle system are dependent on the operational requirements established for each mission. The type of rendezvous technique; the payload pointing requirements; the operational constraints; length of mission; orbit transfer requirements; etc., determine the performance capability for any particular mission. The data presented herein represents the capabilities of the Space Shuttle system for typical sets of operational requirements. Certain items of equipment, consumables, etc., which are mission unique must be considered as part of the total payload and in planning for a particular mission must be included as part of the payload weight. In addition, the OMS and RCS are loaded to meet the specific on-orbit maneuver requirements and not necessarily to the total loading capacity.

Figure II-8 shows the maximum payload weight that can be placed into a circular orbit from KSC as a function of placement orbit altitude and inclination. The payload weights shown are based on the SSV configuration used in the reference missions and on orbital maneuvers that are limited to a Hohmann transfer from apogee of a 50- by 100- nmi ascent ellipse to the payload replacement altitude, circularization at this altitude, and a direct descent deorbit maneuver from Orbiter up to 500 nmi. A 22-fps orbital reserve is carried for contingency operations.

The integral orbital maneuvering subsystem (OMS) propellant tanks aboard the Orbiter carry only enough propellant to permit an empty Orbiter to ascend to, and return from an altitude of approximately 300 nmi. This altitude is reduced to approximately 225 nmi when the Orbiter carries its maximum payload. During ascent, main engine cutoff (MECO) occurs when the Orbiter is still at a suborbital velocity. The MECO location and velocity governs the impact geometry of the external tank (ET). OMS propellant is then used to complete the ascent. Low inclination missions launched from Kennedy Space Center (KSC) nominally require 100 fps from the OMS to attain the required orbital velocity.

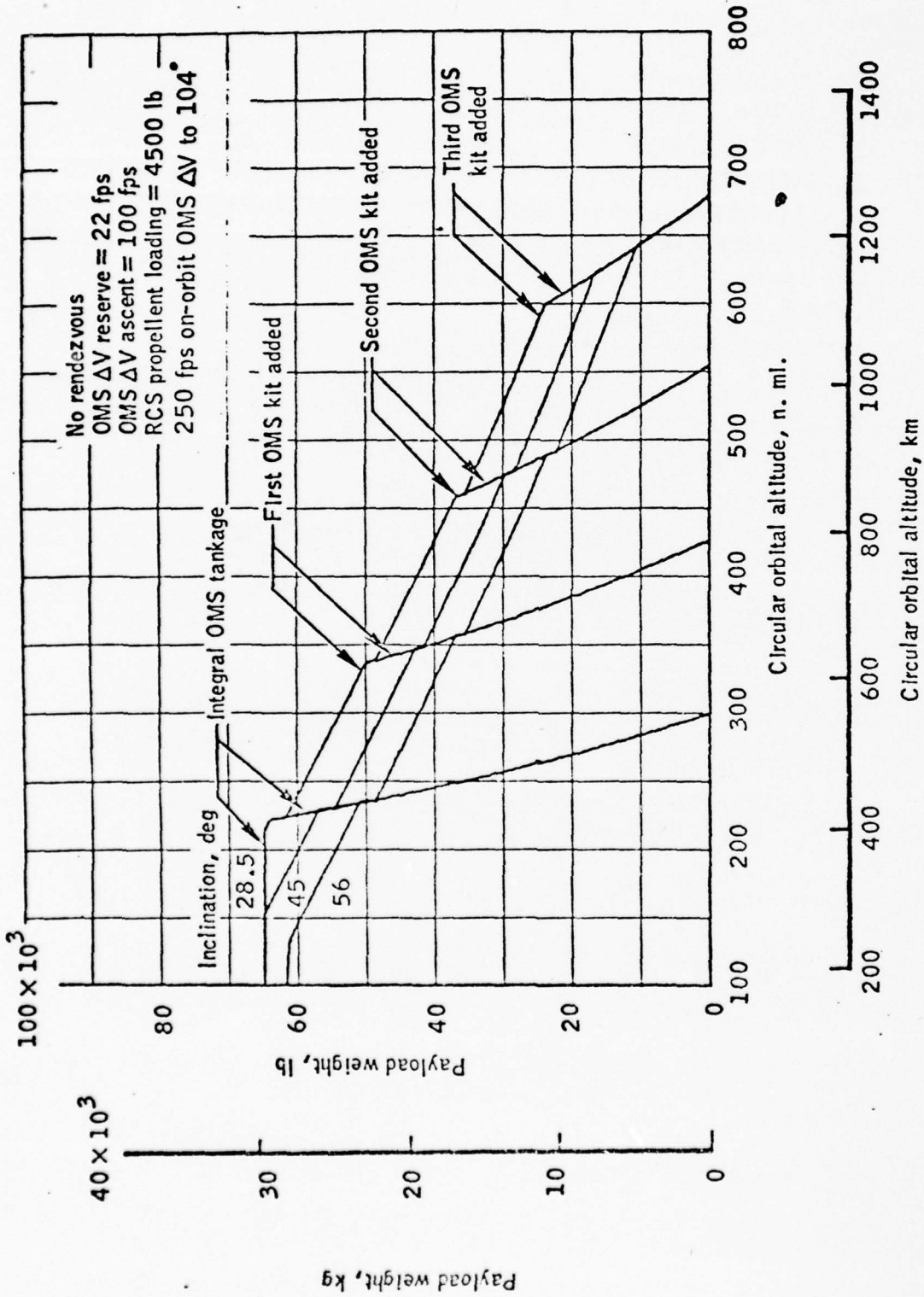

Figure II-8. Payload Weight versus Circular Orbital Altitude--KSC Launch, Delivery Only

APPENDIX B: STS Operations Concepts

Extracts of DOD Annex to Baseline Operations Plan;  
NASA/JSC; draft dated May 1976; incl. Joint Memo-  
randa dated 10 June 1976



NATIONAL AERONAUTICS AND SPACE ADMINISTRATION  
LYNDON B. JOHNSON SPACE CENTER  
HOUSTON, TEXAS 77058

REPLY TO  
ATTN OF CF3 (76-158)

JUN 10 1976

TO: Distribution

FROM: CA/Director of Flight Operations  
LVRO/Assistant Program Director, Space Transportation  
System Program Office

SUBJECT: Draft of the Department of Defense Annex to the Baseline  
Operations Plan

The Department of Defense (DOD) Annex to the Baseline Operations Plan (BOP) defines a joint National Aeronautics and Space Administration (NASA)/DOD operations concept for planning and controlling a Shuttle mission with a DOD payload. This document was jointly developed by Johnson Space Center and Space Missile Systems Organization personnel. This draft is submitted for review within the line organizations of both agencies to obtain a wider review of the concept leading to NASA and DOD management approval.

This concept was specifically written for a DOD Interim Upper Stage (IUS)/Satellite mission; however, it will apply to other DOD payloads to be flown prior to Vandenberg Air Force Base initial operations capability to support a Shuttle launch.

Comments on this document should be submitted no later than June 28, 1976, for joint signoff on approximately July 19, 1976.

Comments should be submitted to:

NASA - Mr. John H. Temple  
CF3  
NASA/JSC  
Houston, TX 77058  
Phone - 483-3511

DOD - Lt. Col. R. E. Lindemuth  
SA 10/LVRO  
Wardway Postal Center  
P.O. Box 92960  
Los Angeles, CA 90009  
Phone - 793-1590

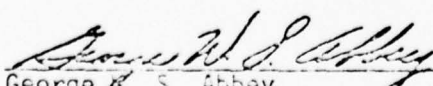
  
George A. S. Abbey  
Director of Flight Operations

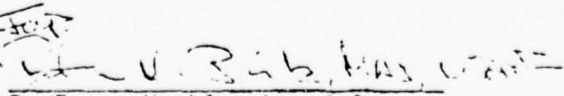
  
D. E. Verble, Lt. Col.  
Assistant Program Director,  
Space Transportation System  
Program Office

JSC-10531

# DOD ANNEX

## TO

REVIEW DRAFT

Baseline  
Operations  
Plan

MAY 1976

Prepared by  
FLIGHT CONTROL DIVISION  
Flight Operations Directorate



*National Aeronautics and Space Administration*  
**LYNDON B. JOHNSON SPACE CENTER**  
*Houston, Texas*

## SECTION 1

INTRODUCTION

## 1.1 PURPOSE

This annex to the JSC Baseline Operations Plan (BOP) represents a joint JSC and DOD operations plan for STS and payload operations for DOD missions as of May 1976.

This annex is not intended to stand alone but summarizes the NASA baseline concept for planning, training, and operations with the emphasis on unique aspects of these activities for DOD flights. This one annex describes the joint NASA/DOD operation; however, reference must be made to the three JSC BOP's for the OFT, Operations Transition, and Operations phases.

This plan is primarily conceptual in nature and is not intended as a control document. However, it does represent a jointly-agreed-to operations concept and should provide the basis for generic ground facilities requirements.

## 1.2 APPROACH

A NASA/DOD working group was established to develop a plan demonstrating how NASA and the DOD could work together in the planning, training, and execution of a flight with DOD payloads. Certain basic assumptions and agreements were defined to serve as a baseline for developing a joint operations concept and to use as a tool for management review prior to beginning the development of this document. These basic points are contained in Section 1.3. The approach was to develop an operations concept in the form of a review draft and submit it for both NASA and DOD review within the line organizations of both agencies.

The primary issue that surfaced in the early work was the manner of implementation of DOD security requirements. Options are being studied as to which security requirements will be implemented by JSC, and the manner in which they could be implemented. For this reason, the DOD annex has been divided into descriptions of three operational concept phases:

Phase 1A (1976 - Dec. 1982)

This phase covers STS planning, training, and real-time operations for DOD flights prior to VAFB launch readiness. SSV flight planning, training, and real-time operations are performed by JSC in an unclassified manner. IUS/Satellite flight planning, parts of training, and real-time operations will be performed by the DOD at the SCF.

Phase 1B (1977 - Dec. 1985)

This phase covers STS planning, training, and real-time operations after VAFB launch readiness but before DOD control capability of the SSV. SSV flight planning, training, and real-time operations are performed at JSC. IUS/Satellite flight planning, parts of training, and real-time operations will be performed by the DOD. Extensive security requirements on JSC exist in this phase. Investigation of security workarounds to minimize security at JSC is continuing.

Phase 2 (After DOD MCC with Orbiter Control Capability)

This phase covers all STS operations associated with DOD flights launched after STS control capability from a DOD facility exists, DOD becomes the Shuttle operator and assumes responsibility for total STS flight planning and operations for both Shuttle and IUS. It has not been determined, at this time, if this capability will be implemented.

Figure 1-1 shows the relationship between NASA and DOD program phases.

This issue of the annex contains a concept specifically written for an IUS/Satellite flight in Phase 1A. However, the same concept will be applied for any DOD payloads during OFT as well as other payloads during Phase 1A which may require minimum JSC security similar to the IUS/Satellite flight.

It should be noted that the DOD Phase 1A generally coincides with the NASA transition phase. Therefore, it is necessary to define how the joint operations will exist for a complete and dedicated ground team concept (early transition period) to a reduced team concept (ops period). The Annex will be expanded to cover Phases 1B and 2 as the DOD security requirements are defined.

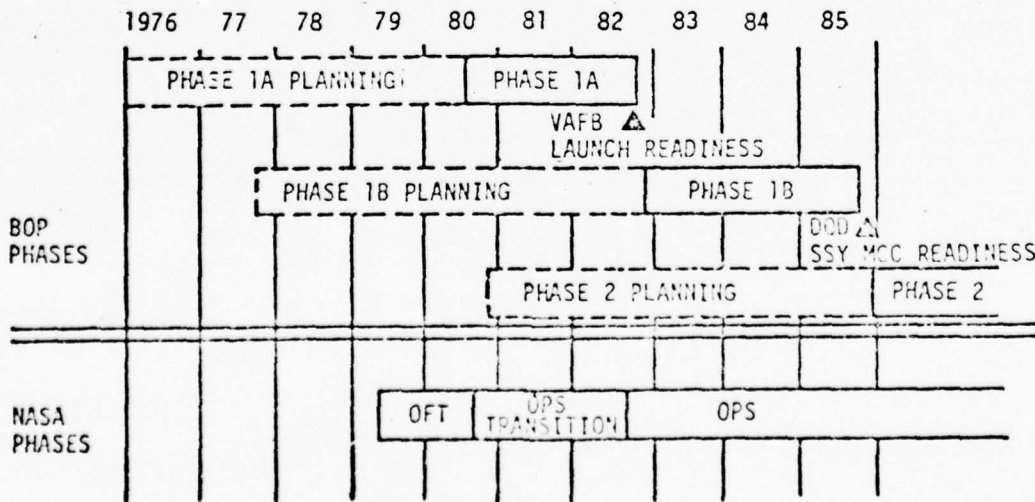

Figure 1-1.- NASA/DOD phases.

## SECTION 2

MISSION OPERATIONS CONCEPT FOR PHASE 1A

## 2.1 DOD PHASE 1A FLIGHT DESCRIPTIONS

2.1.1 Introduction

Every prime DOD flight in the 1980-1982 timeframe will be launched from the Kennedy Space Center (KSC) and requires the use of the Interim Upper State (IUS) to place the satellite in its required orbit.

In this period, the DOD prime STS flights fall into three flight categories.

- Synchronous equatorial flights.
- High altitude flights with inclinations  $\leq 28.5^\circ$ .
- High altitude flights with inclinations  $\leq 63.4^\circ$ .

The first flight category is characterized by a reference flight profile called Operations Design Mission A. It describes deployment of geosynchronous equatorial satellites.

The second flight category is so similar to Operations Design Mission A with respect to Shuttle flight operations (i.e., Orbiter, external tank, and solid rocket boosters) that a separate and different reference flight profile is not required.

The third flight category is characterized by a reference flight profile called Operations Design Mission B. It deploys one or more satellites in a highly elliptical orbit inclined  $63.4^\circ$ .

In addition to these DOD sponsored flights, it is expected that some secondary DOD payloads will be flown on a space-available basis. These payloads may be attached or detached and flown on either NASA or DOD sponsored flights. They are characterized as a non-interfering payload deployed from a reference flight profile characteristic of the prime payload. No security impact to NASA will be imposed by these secondary payloads. Other agreements and assumptions in Section 1.3 also apply.

2.1.2 Flight Descriptions

2.1.2.1 Operations Design Mission A.- The objective of the Operations Design Mission A reference flight is to deploy one or more satellites in a geosynchronous, nearly equatorial orbit. The flight requirements are summarized in Table 2.1-I.

TABLE 2.1-I.- OPERATIONS DESIGN MISSION A FLIGHT REQUIREMENTS

<u>Item</u>	<u>Requirement</u>
Number of satellites .....	2
Satellite Deployment Orbit Parameters*	
• Apogee altitude (n.mi.) .....	19323
• Perigee altitude (n.mi.) .....	19323
• Inclination (deg) .....	2.9
• Right ascension of ascending node (deg) .....	250-339
• Longitude .....	No requirement

\*Both satellites deployed in same region.

Figures 2.1-1 and 2.1-2 detail the Orbiter events and IUS flight profiles for this Operations Design Mission A reference flight.

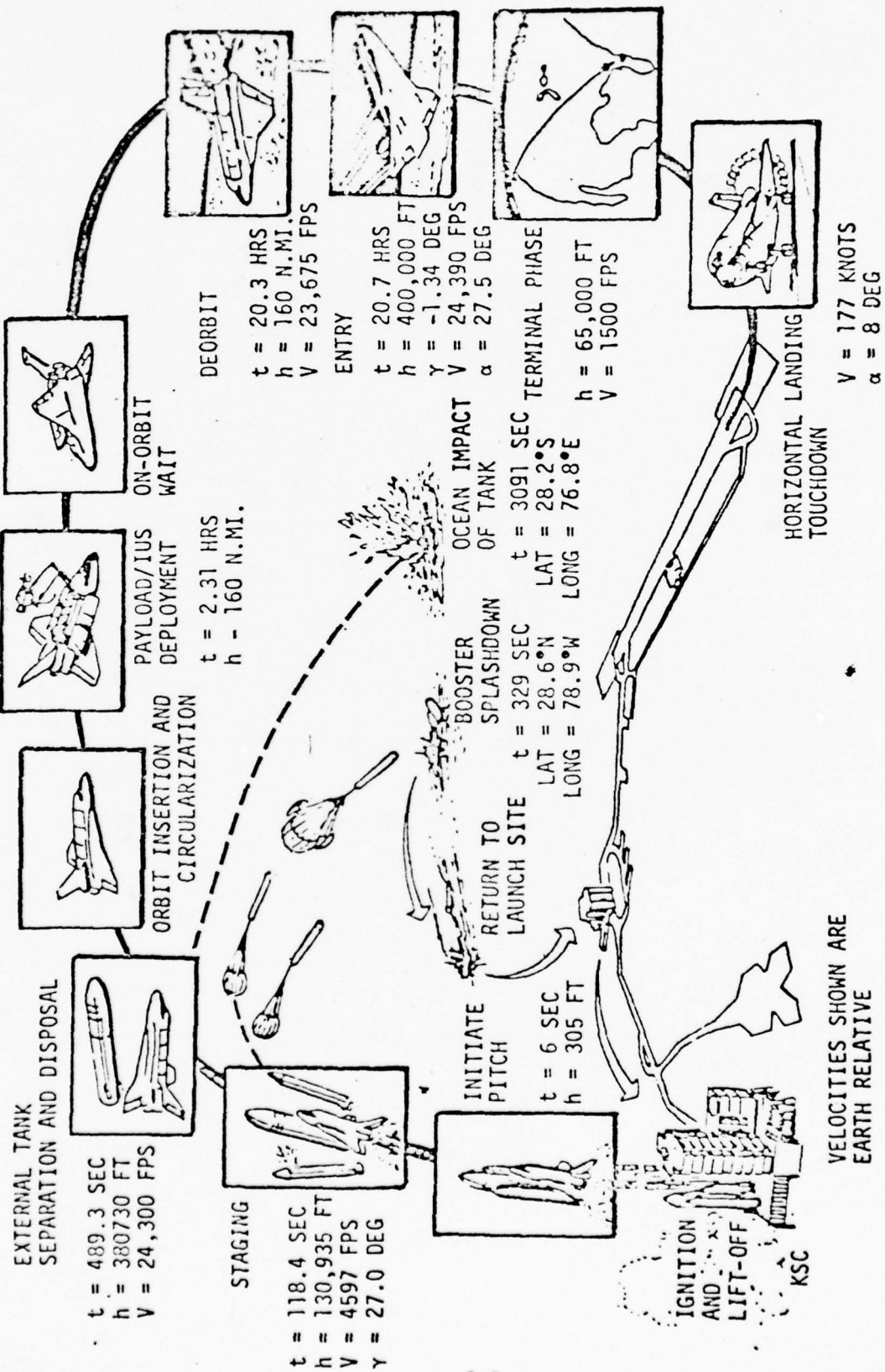
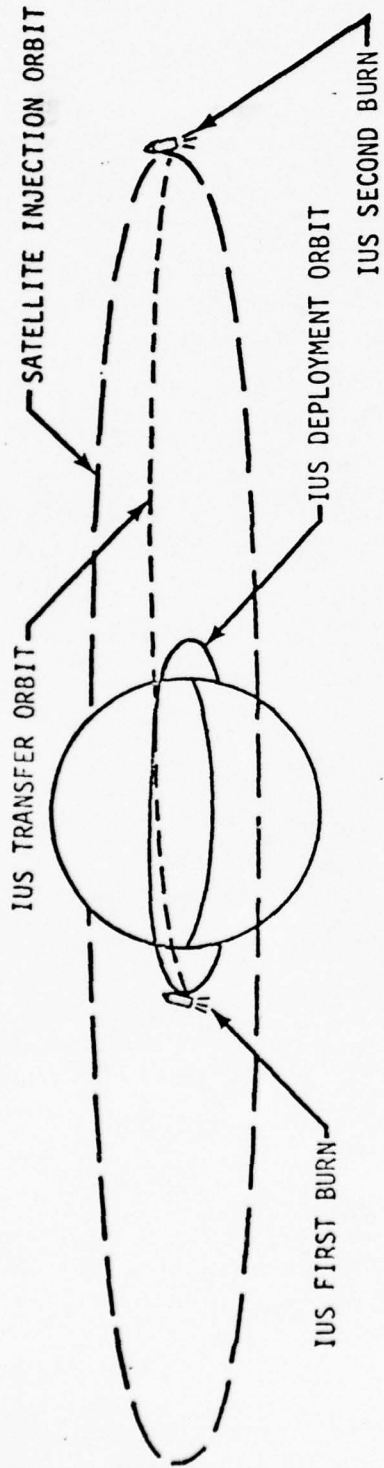

Figure 2.1-1.- Operations Design Mission A Orbiter Events



EVENT (GET)	$\Delta V$ (FT/SEC)	INITIAL PERIGEE/APOGEE (NMI)	INITIAL INCLINATION (DEG)	FINAL PERIGEE/APOGEE (NMI)	FINAL INCLINATION (DEG)
IUS FIRST BURN (2:41:46)	8032	154/165	28.5	154/19421	26.5
IUS SECOND BURN (7:57:09)	5663	156/19324	26.5	19323/19324	2.9

Figure 2.1-2.- Operations Design Mission A IUS profile.

2.1.2.2 Operations Design Mission B.- The objective of the Operations Design Mission B reference flight is to deploy one or more satellites in a 400 x 21260 n.mi. orbit inclined 63.4°. The flight requirements are summarized in Table 2.1-II.

TABLE 2.1-II.- OPERATIONS DESIGN MISSION B FLIGHT REQUIREMENTS

<u>Item</u>	<u>Requirement</u>
Number of satellites .....	1
Satellite Orbit Parameters*	
• Apogee altitude (n.mi.) .....	21260
• Perigee altitude (L.mi.) .....	403
• Inclination (deg) .....	63.4
• Right ascension of ascending node (deg) .....	0
• Argument of perigee (deg) .....	270

\*Measured at first apogee.

Figures 2.1-3 and 2.1-4 detail the Orbiter events and IUS flight profile for this Operations Design Mission B reference flight.

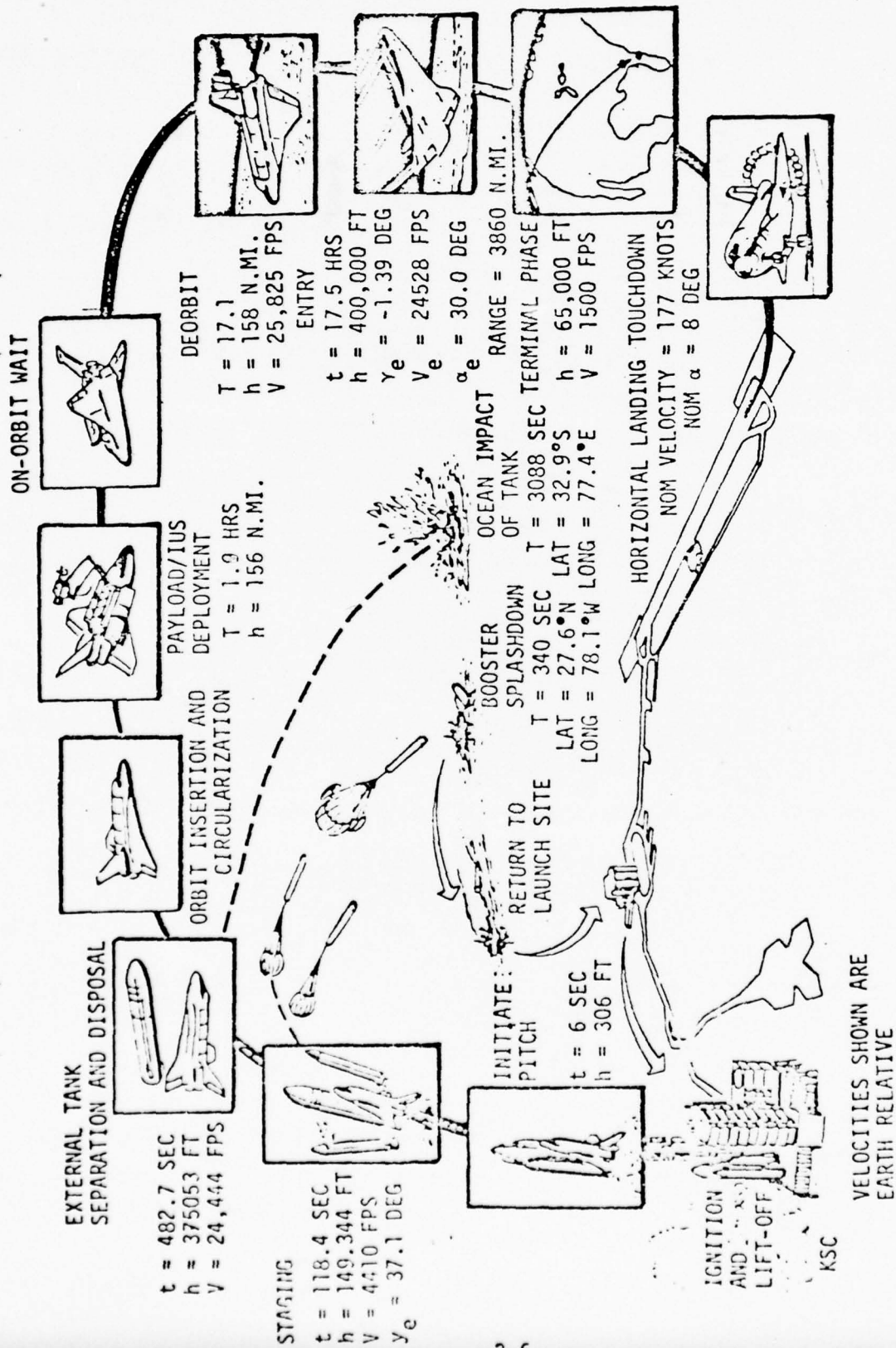
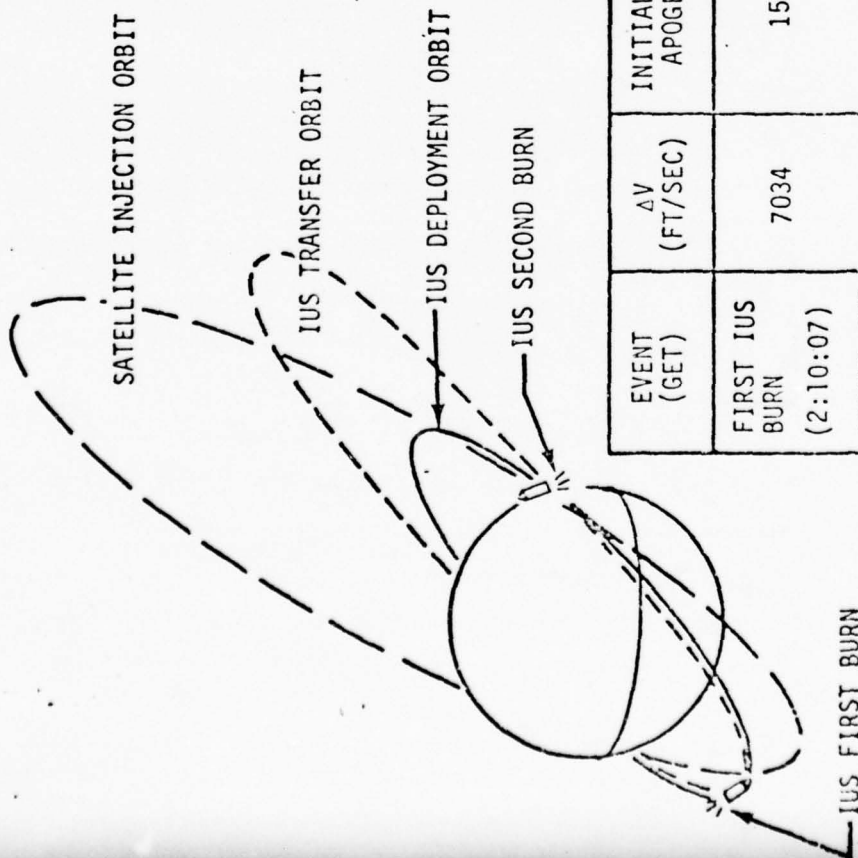

Figure 2.1-3.- Operations Design Mission B Orbiter Events.



EVENT (GET)	$\Delta V$ (FT/SEC)	INITIAL PERIGEE/APOGEE (NMI)	INITIAL INCLINATION (DEG)	FINAL PERIGEE/APOGEE (NMI)	FINAL INCLINATION (DEG)
FIRST IUS BURN (2:10:07)	7034	154/155	37.5	156/12471	37.5
SECOND IUS BURN (3:10:13)	6992	157/12476	37.5	402/21267	63.4

Figure 2.1-4.- Operations Design Mission B IUS profile.

## 2.2 PREFLIGHT OPERATIONS

### 2.2.1 Conceptual Mission Design and Evaluation

The DOD will perform the conceptual mission design for the Phase 1A DOD flights using Satellite SPO mission objectives and satellite characteristics, and NASA supplied Shuttle (i.e., Orbiter, ET, SRB's) characteristics. The primary purpose of this assessment is to determine whether or not the satellite flight requirements can be satisfied by the STS flight resources and ground resources within satellite program constraints.

The DOD conceptual mission design is comprised of the functions described in the paragraphs that follow.

2.2.1.1 Satellite flight requirements and data definition.- The Satellite SPO will define the satellite deployment and support requirements. These will include all appropriate IUS/Satellite/Orbiter interface requirements and data. In addition, the Satellite SPO will furnish data such as satellite operational constraints, command and data system requirements, checkout requirements, and mass properties. The Satellite SPO will provide these data to the DOD STS organization.

2.2.1.2 Flight feasibility study.- The DOD will perform a flight feasibility study utilizing the Satellite SPO data, the STS flight system data, the STS ground system data, and IUS systems data.

2.2.1.3 Flight candidacy review.- The objective of this function is to accept or reject proposed satellite flight requirements. The DOD will make an evaluation of consumables usage, flight systems and ground support systems capability and availability, and crew timeline requirements utilizing the Satellite Flight Requirements and Satellite Data Book, the Flight Feasibility Study results, and JSC 0700 Space Shuttle System Payload Accommodations, Vol. XIV. This evaluation will lead to a formal acceptance of the candidate DOD STS flight (i.e., Orbiter, ET, SRB's, Spacelab, and IUS) or rejection of the flight with documented reasons issued to the Satellite SPO.

2.2.1.4 IUS/Satellite SSV flight requirements definition.- The purpose of this function is to define the flight operations requirements imposed on the Shuttle by the IUS/Satellite and to furnish the unclassified data necessary for Shuttle flight designs.

Using the data furnished by the Satellite SPO, the DOD STS organization will prepare an unclassified document containing the IUS/Satellite flight requirements and data. The contents will include the following:

- IUS/Satellite deployment requirements
- Operational constraints
- Telemetry requirements
- Command requirements
- IUS/Satellite mass properties
- Flight checkout requirements
- Caution and warning data
- Any other data required for Shuttle flight planning

The unclassified report will be delivered to the NASA/JSC for planning.

2.2.1.5 NASA STS utilization planning operations support.- The function will provide support to NASA during STS utilization planning and flight scheduling operations, and provide an interface between the DOD and NASA. A major activity of this function will be to provide NASA with the unclassified IUS/Satellite data and DOD resource availability data to support NASA's utilization planning and scheduling analysis.

## 2.2.2 STS Utilization Planning

The NASA will perform the STS utilization planning required to support DOD STS flight requirements. The DOD will support the STS utilization planning as described above. A major function of STS utilization planning is STS flight scheduling.

Based upon the results of the DOD flight candidacy review, the satellite assignments to specific DOD STS flights will be requested for NASA flight scheduling.

After receipt of the IUS/Satellite flight requirements and data from DOD, the NASA will conduct its own flight acceptance review. The result of this review will be the addition of the flight to the master launch schedule.

BEST AVAILABLE COPY

### 2.2.3 Flight Planning

The flight planning for each DOD STS flight will consist of two major activities: (1) flight planning for the Shuttle, and (2) flight planning for the IUS/Satellite. NASA/JSC will carry out flight planning for the Shuttle and DOD will carry out flight planning for the IUS/Satellite. The two flight planning activities are related and will be coordinated.

The flight planning process nominally begins five years before launch and continues up to launch. The time phases within this period are:

- Long-Range Planning - 5 to 2 years before launch
- Preliminary Design - 2 years to 6 months before launch
- Operational Design - 6 months up to launch

2.2.3.1 Shuttle flight planning.- NASA/JSC will perform the flight planning for the SSV flight portion of the DOD flights. The Shuttle flight planning activities include three main functions: (1) flight design, (2) flight crew activity planning, and (3) flight operations planning.

2.2.3.1.1 Shuttle flight design: NASA/JSC will perform the Shuttle flight design using the IUS/Satellite flight requirements and data furnished by the DOD. For Phase 1A the Shuttle flight design will be unclassified.

2.2.3.1.2 Flight crew activity planning: The flight crew activity planning for DOD flights will follow the same basic flow as for NASA flights with IUS deployment. The planning will be unclassified, since the crew does not perform IUS or satellite checkout. The DOD will furnish the requirements for the IUS/Satellite for launch, ground commanded checkout, deployment and contingencies. If crew visual observations of the IUS/Satellite checkout are required, these will be identified and scheduled as blocks of crew time by NASA/JSC. The DOD will provide the detailed crew activity timelines for these time blocks and prepare the necessary part, of the Flight Data File (FDF) furnished by DOD.

The FDF which contains the integrated summary crew activity plan, the crew procedures, and crew reference data will be made available by NASA/JSC at launch minus 8 weeks to support flight team assignment and training. The final version will be made available at launch minus 4 weeks to support integrated simulations. The DOD will furnish the classified portions of the FDF.

BEST AVAILABLE COPY

2.2.3.1.3 Shuttle flight operations planning: In the time period within approximately 16 weeks of launch, operating procedures, plans, and documentation required to prepare the flight crew, Shuttle operations center, and its interfaces for a flight are finalized by NASA/JSC. The DOD will support this development to provide support for the DOD flights, as described for other POC's in the Operations BOP. The product of this activity is a flight implementation package consisting of: Flight Rules, STS/Payload Command Plan, console handbooks, STS data base, Communications and Data Management Plan, Flight Operations Integration Handbook, Flight Training Plan, et cetera.

The DOD will provide inputs in the development of these documents. In addition, the DOD will specifically be responsible for documenting and coordinating any parts of the documents or materials that are classified.

2.2.3.2 IUS/Satellite flight planning: DOD will perform the flight planning for the IUS/Satellite flight portion of the DOD flights. IUS/Satellite flight planning consists of two functions, flight design and flight operations planning. DOD IUS/Satellite flight planning will be performed in a secure environment. It will also be coordinated with NASA Shuttle flight planning and receive and supply necessary information.

2.2.3.2.1 IUS/Satellite flight design: The flight design activity nominally commences three to five years prior to launch with a preliminary design. Where both the satellite type and flight requirements are very similar to those for a previous flight, the shorter lead time may apply. The IUS/Satellite flight design function is an integrated effort with the SSV flight design function. As a part of the Shuttle flight design, NASA/JSC will generate a Shuttle ascent trajectory. The DOD will generate the IUS flight design based on the SSV insertion state vector (from the Shuttle ascent trajectory) and the satellite deployment targets.

The IUS/Satellite flight design includes the following activities:

- IUS trajectory definition
- IUS ground tracking station coverage analysis
- IUS consumables profile analysis
- IUS attitude profile determination
- IUS/Orbiter relative motion data computation
- Orbiter attitude profile analysis during attached IUS/Satellite checkout
- Crew activity plan development for IUS control handover
- IUS/Satellite Flight Data File (FDF) inputs to NASA/JSC
- Crew and vehicle safety analyses

BEST AVAILABLE COPY

APPENDIX C: JSC Mission Control Study (Joint-Agency)

Extracts; Ground Rules

: Study Plan

agreed to 24 May 1976 by SAMS0/LVR

## PROPOSED STUDY GROUND RULES

### I. GENERAL

1. The DOD SEC requirements as compiled by the STS SPO apply to all classified DOD payloads 1982-1990.
2. Not all DOD payloads are classified. The unclassified DOD payloads can be handled in a manner similar to NASA payloads.
3. The DOD Mission Model as specified in Rev. 5, dated February 76, applies to the study. No other DOD missions are inferred.
4. The NASA 572 Flight Model will be used as the basis for sizing and costing the systems. Where implementation would have been different for reduced traffic, these alternative plans will be investigated.
5. The study will compare secure operations from JSC with secure operations from a separate DOD SOPC. Operations from an unsecured JSC for classified DOD payloads in the 1982-1990 time frame is not a viable option.
6. Mission planning and control for the DOD IUS as a baseline will be accomplished by the DOD. The study will include Delta costs for NASA performing this function for the DOD.
7. Flight feasibility assessment for DOD payloads will remain a DOD responsibility and function.
8. NASA will provide implementation details and cost data for NASA performed functions. DOD will provide implementation details and cost data for functions performed by DOD.
9. The study will result in two principal outputs: Quantitative Data and Qualitative Data. Quantitative Data includes delta manpower and cost figures. Qualitative Data will include all significant impacts identified and will be discussed in terms of pro's and con's for the implementation options.
10. The study will be limited to mission operations functions at JSC only. Other related facilities or systems, such as the KSC Launch Facilities, will not enter into costing considerations.
11. The current "NO COMSEC" orbiter baseline will be used as an initial study ground rule.

## II. COSTING GROUND RULES

1. Costs will be estimated as "costs to the Government".
2. Costs will be reported in constant 1975 dollars.
3. Total life cycle cost will be estimated. The life cycle will be defined to be from 1 October 1976 through December 1991.
4. Costs at JSC will be treated as "delta" costs to costs which NASA would normally incur if there were no classified DOD flights.
5. NASA will estimate costs incurred at NASA facilities and to NASA operated and/or controlled equipment. DOD will estimate cost incurred at DOD facilities and to DOD operated and/or controlled equipment.
6. Cost data will be estimated as non-recurring and recurring costs.
  - a. The non-recurring costs consist of the one-time costs of acquiring the resources or capabilities required to support DOD-STS missions. These include the costs of:
    1. Concept definition
    2. Requirements analysis
    3. Specifications
    4. Procurement action
    5. Development
    6. Design
    7. Production or purchase
    8. Test
    9. System engineering and integration
    10. Activation of operational facility
    11. Initial training
    12. Documentation
    13. Management
    14. Administrative Support

- b. The recurring costs consist of the repetitive support and services required to use and apply the resources in planning, preparing for, and controlling DOD STS missions. These include:
  - 1. Flight planning
  - 2. Flight design
  - 3. Flight scheduling
  - 4. Post-flight analysis
  - 5. Flight-specific crew training
  - 6. Flight-specific rehearsals
  - 7. Real-time flight control
  - 8. Data base updating
  - 9. Hardware and software maintenance
  - 10. Support management
  - 11. Administrative support
- 7. The cost elements to be used for bottom-line summaries of life cycle cost will be specified. Typical examples are:
  - a. Operations planning
    - . Utilization planning
    - . Flight planning
  - b. Training
    - . Flight crew
    - . Ground crew
  - c. Flight Operations
    - . Data load generation/verification
    - . Ground support
    - . Communications

d. Other

- . Management
- . Test and evaluation
- . Orbiter/IUS software
- . Physical plant/facilities
- . General administrative support
- . Data processing
- . MOS integration

8. All labor categories and cost rates used for cost estimates will be documented.

JOINT NASA/DOD  
STUDY ON IMPACT  
OF SECURITY AT JSC  
FOR PHASE 1B OPERATIONS

April 26, 1976

SAMSO-LVRO  
JSC-SPIDPO

### Objectives

- o To determine DOD security requirements.
- o To derive operations concepts and implementation options for secure operations at JSC.
- o To determine impacts to JSC for selected options.

### Products

- o Documented security requirements
- o Operations concept(s) for secure ops at JSC
- o Implementation options for JSC
- o Impact assessment (dollars, schedule, other considerations)
- o Recommended concept and implementation configuration

### Task 1. Development of Security Requirements

- a. The DOD (LVR) will coordinate with DOD payload SPO's to determine their security requirements.

#### Task 1A

- a. Prepare requirements in a form readily used by joint DOD/NASA team in remainder of study. This preparation is to include any explanation or implementation instructions necessary to simplify understanding of what requirements mean from an operations concept or implementation options standpoint.

- b. The requirements will be presented to HQ USAF/NASA for approval. Task 1 will be the responsibility of SPIPO and LVRO. TRW will assist as necessary.

Task 2. Operations Concept Development

a. Develop an operations concept and a top level implementation option (plus alternatives, if necessary) to satisfy DOD security requirements as documented in Task 1A.

b. Evaluate alternative implementation options that will meet the operations concept(s) and DOD security requirements. Evaluation to include cost, schedule, other considerations, etc.

c. Develop detailed implementation plan.

Task 2 will be an FOD/DSAD responsibility. LVRO, USAFSS, and contractor assistance will be required.

Task 3. Obtain USAF Review and Approval of Implementation Options

Task 4. DOD SOPC Alternative

a. NASA to review and coordinate on current LVRO/TRW study.

b. Develop cost and other applicable data for DOD to provide minimum capability shuttle operations and planning center comparison.

Task 4 is an LVRO responsibility with JSC assistance.

Task 5. Study Review

a. A joint DOD/NASA review will be held for final presentation.

b. The joint review group will make recommendations and select material for presentation to HQ level DOD/NASA.

Study Plan Notes

Successful accomplishment of a security impact study is predicated on establishing credible security requirements.

The lead in the study must be borne by NASA so that operations concepts and implementation options are accomplished by those who know the operations system. As NASA is limited in manpower and other resources, it is critical that the DOD provide major assistance. This can be accomplished by TRW being directed to provide assistance as required. Additionally, JSC will obtain contractor assistance (probably Aeroneutronic-Ford) as required. Assistance by AFSS will also be required. They should be requested to assist NASA in determining what is required to meet the security requirements.

The tasks described in this study will require very close cooperation between DOD and NASA. It will also require iteration between various security requirements, ops concepts, and implementation options to provide for understanding of how much impact is caused by requirements and how ops concepts could be modified to simplify implementation options.

A task has been included to price a minimum DOD SOPC. This will provide a baseline to understand the viability of securing JSC. Extreme care must be exercised by both DOD and NASA so that "oranges and oranges" are being compared.

NASA-S-76-2736

# STUDY SCHEDULE

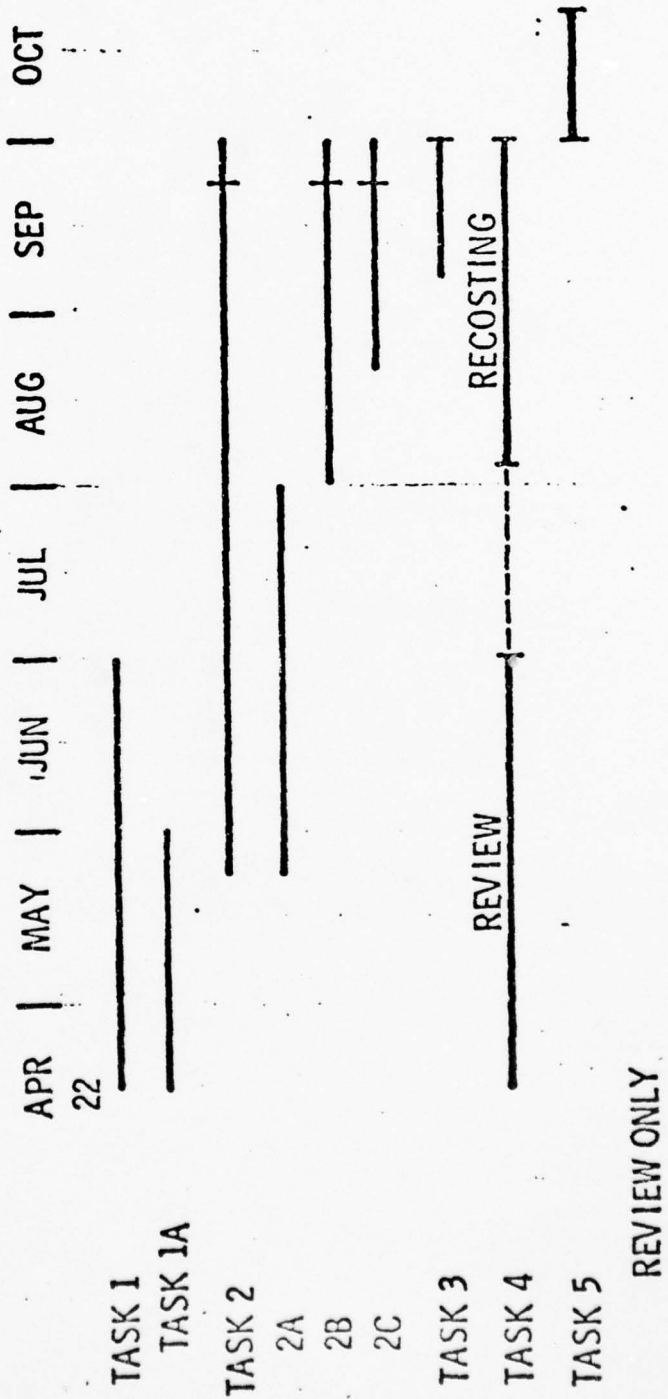

APPENDIX D: Minutes - SAMSO/OSF Meeting; 15 January 1976

As recorded by executive assistant to the Deputy  
Associate Administrator for Operations; HQ NASA,  
dated 20 January 1976.

STS MEETING BETWEEN SAMSO AND OSF

January 15, 1976  
Washington, D. C.

In response to a request from SAMSO expressing a need for a direct interface with OSF because of a number of STS problems which do not fall within the jurisdiction of NASA Centers, Mr. Yardley agreed to the need for such meetings with the first held on January 15, 1976. It was agreed the first meeting should be an informal round-table discussion with topics submitted by SAMSO and OSF. Enclosed is a copy of the agenda of topics used for discussion purposes. Also enclosed is a list of attendees.

1. Purpose and Scope of Meeting

There was considerable discussion on the purpose and scope of the meeting. It was agreed a mechanism is needed to obtain better understanding of STS issues within OSF and SAMSO, with designated individuals or groups in each of the two agencies to work these issues. Gen. Stelling expressed a need for an organizational mechanism in the form of a joint management concepts document. Mr. Yardley requested issues be determined and a structure developed in three broad categories: (1) development, (2) integration, and (3) operations, with responsible working groups or key people identified. A proposal incorporating the above agreements was requested by Mr. Yardley within two weeks.

ACTION: Mr. Griffin and Gen. Stelling

2. December USAF Program Review Results/Actions

Col. Browning discussed the December USAF program review results. (1) With respect to VAFB, there is a basic issue of when to start construction and IOC. (2) Options are being reviewed relative to transition from expendable launch vehicles to Shuttle with an AF plan expected by May, 1976. Mr. Yardley emphasized there are issues which need to be resolved on expendable launch vehicles and Gen. Stelling agreed to review this area before submitting the final report. Mr. Yardley asked Capt. Lee to also work this area with particular emphasis on tradeoffs of flying the Delta launch vehicle from ETR vs WTR.

AD-A038 673

DEFENSE SYSTEMS MANAGEMENT COLL FORT BELVOIR VA  
OPERATIONS MANAGEMENT OF DOD SPACE MISSIONS IN THE SHUTTLE ERA. (U)  
NOV 76 C J TRINGALI

F/G 22/2

UNCLASSIFIED

NL

2 OF 2

AD  
A038673



END

DATE  
FILMED  
5-77

In addition, Capt. Lee was asked to conduct a study of cross utilization of Titan launch personnel and Shuttle (Martin) personnel for effective utilization of people and cost effectiveness for back-up Titan launches.

ACTION: Capt. Lee

(3) With respect to economic benefits, Col. Browning stated a contract is being let this month to study economic benefits. Mr. Yardley asked Mr. Disher to coordinate an NRL letter on this subject with Gen. Stelling.

ACTION: Mr. Disher

3. VAFB STS Operations Costs and SAMSO Participation in Operations Manpower Studies

Capt. Lee discussed a need for SAMSO participation and input regarding VAFB relative to NASA manpower studies to be presented to the NASA Administrator in May. Gen. Stelling requested Capt. Lee to supply the groundrules and Col. Verble from SAMSO to be the Air Force contact point in this area.

ACTION: Capt. Lee/Col. Verble

4. Security/Ops Study on MCC at JSC

Use of JSC MCC and the need for a DOD separate MCC were discussed. The plan is to use JSC MCC, but impacts are being looked at relative to security and traffic rate increase. Security aspects of payloads were discussed. Capt. Lee requested a coordinated list of DOD security requirements. It was agreed that NASA operations people would continue to work on areas relative to MCC planning and that USAF would attempt to pull together a total list of security requirements.

ACTION: Capt. Lee/Gen. Stelling

Payload safety issues with respect to the Orbiter were discussed including separation from the orbiter and communications link. There is a need to analyze the total problem including IUS and free flyers.

Mr. Griffin was requested to review with all concerned parties at Hqs. and JSC the safety requirements of payloads in or near the Orbiter; and particularly, the requirement for an RF link between the Orbiter and payload should be thoroughly understood and removed or, at least, minimized.

Dr. Malkin and Capt. Lee were requested to review the present groundrules with respect to operational constraints and DOD use of TDRSS and costs.

ACTION: Dr. Malkin/Capt. Lee

The Air Force was requested to review Air Force policy with respect to TDRSS.

ACTION: Gen. Stelling

5. Potential USAF Use of Spacelab and/or Pallets

Mr. Lord is working on an MOU with respect to USAF use of Spacelab and/or pallets. Col. Browning requested an information briefing on Spacelab.

ACTION: Mr. Lord

6. Updated STS Mission Model (USAF Rev. 5 vs NASA)

Col. Browning stated the USAF Rev. 5 of their updated Mission Model is being submitted to USAF Headquarters for approval. Mr. Yardley stated NASA has a traffic model.

User charge policy was also discussed. Data will be needed on Vandenberg. Mr. Yardley stated Capt. Lee and Mr. Culbertson are NASA contact points in this area. After Mr. Culbertson reports to his new assignment, Capt. Lee will be the contact point.

7. USAF STS Vulnerability Study

A special Air Force panel is studying STS vulnerability. Gen. Stelling intends to obtain OSF concurrence on the study document.

8. VAFB Reference Mission

Col. Browning and Lt. Col. Essmeier discussed a new reference mission. Mr. Yardley was not in favor of using the "Goddard" mission and requested Dr. Malkin to discuss with JSC personnel the need for a simple circular orbit with reasonable altitude and inclination.

ACTION: Dr. Malkin

9. Agenda for STS Execs Meeting

Col. Browning requested guidance relative to an Air Force briefing at the STS execs meeting. Mr. Yardley suggested a status type briefing.

10. USAF/NASA STS Documentation System

This area was briefly discussed with respect to a need for a common documentation system insofar as possible.

Col. Essmeier mentioned differences in documentation relative to configuration management. Mr. Yardley asked Capt. Lee to review the Delta procedures of KSC vs WTR for duplication and/or commonality regarding configuration management documentation.

ACTION: Capt. Lee

11. NASA Management Structure for the IUS and Its Interfaces with SAMSO

Gen. Stelling discussed the possibility of an Air Force test flight for the first IUS to be charged to the test program. Mr. Yardley asked Mr. Disher to look at the test flight program for IUS to determine if this could be worked into the schedule. Flight #6 was discussed as a possibility.

ACTION: Mr. Disher/Mr. Culbertson

Col. Browning discussed IUS validation phase. Mr. Yardley stated MSFC is the designated NASA Center responsible for IUS. Mr. Disher will work with Col. Browning in defining the points of contact at MSFC for the validation phase.

ACTION: Mr. Disher

(Mr. Disher gave Col. Browning a letter from Mr. Yardley to Dr. LaBerge regarding roles plus on-going organizational responsibilities for IUS.)

12. SAMSO Initiatives in Development of an STS User Guide

The Air Force has developed an STS user guide for payloads. Col. Essmeier gave OSF a copy of the guide and requested NASA comments.

ACTION: Capt. Lee/Mr. Culbertson

**13. Payload Studies**

Mr. Culbertson requested adequate advance notice relative to SAMSO briefings on payloads.

**ACTION:** Col. Browning

**14. Future Meetings and Where Do We Go From Here**

Col. Browning requested thought be given to whether future meetings would be worthwhile.

Mr. Griffin handed out a paper on NASA/SAMSO common areas of interest and requested thought be given to individuals with NASA responsibility and individuals with SAMSO responsibility.

**ACTION:** NASA/SAMSO

Gen. Stelling intends to obtain NASA concurrence on the Air Force Program Management Document.

*Rose M. Lovelace 1/26/76*

Rose M. Lovelace

Enclosures

**TOPICS OF DISCUSSION FOR SAMSO/OSF MEETING**

**JANUARY 15, 1976**

**8:30-12:00 - Room 425**

**PURPOSE AND SCOPE OF MEETING**

**DECEMBER USAF PROGRAM REVIEW RESULTS/ACTIONS**

**VAFB STS OPERATIONS COSTS AND SAMSO PARTICIPATION IN OPERATIONS  
MANPOWER STUDIES**

**SECURITY/OPS STUDY ON MCC AT JSC**

**POTENTIAL USAF USE OF SPACELAB AND/OR PALLETS**

**UPDATED STS MISSION MODEL (USAF REV. 5 VS NASA)**

**USAF STS VULNERABILITY STUDY**

**VAFB REFERENCE MISSION**

**AGENDA FOR STS EXEC'S MEETING**

**USAF/NASA STS DOCUMENTATION SYSTEM**

**NASA MANAGEMENT STRUCTURE FOR THE IUS AND ITS INTERFACES  
WITH SAMSO**

**SAMSO INITIATIVES IN DEVELOPMENT OF AN STS USER GUIDE**

**PAYLOAD STUDIES**

**FUTURE MEETINGS AND WHERE DO WE GO FROM HERE**

OSF/SAMSO Meeting

January 15, 1976

Attendees

NASA

Mr. Yardley  
Mr. Griffin  
Capt. Lee  
Mr. Lord  
Mr. Disher  
Mr. Culbertson  
Dr. Malkin  
Mr. Vance  
Mr. Forsythe  
Col. Saavedra  
Mr. Aller  
Gen. Snavelly  
Dr. Walt Williams  
Ms. Lovelace  
Mr. Rose

Air Force

Gen. Stelling  
Gen. Collins  
Col. Browning  
Col. Essmeier  
Col. Verble  
Col. Thompson  
Col. Lee  
Capt. Henry

NASA/SAMSO COMMON AREAS OF INTEREST

RESPONSIBILITY  
NASA                      SAMSO

1. Payload Integration
  - o IUS Integration
    - with Payload
    - with Orbiter
  - o Non-IUS Payload
2. Launch Site Processing
  - o KSC
  - o VAFB
3. Mission Models
4. ELV/STS Transition
  - o Launch Vehicles
  - o Payloads
5. KSC Ground Operations
  - o Facilities
  - o Procedures
6. JSC Flight Operations
  - o Facilities
  - o Procedures (including VAFB launches)
7. VAFB Ground Operations
  - o Facilities
  - o Procedures
8. Mission Planning
  - o Orbiter
  - o IUS
  - o Non-IUS
9. Operations Costs
  - o Hardware
  - o Manpower
10. Cost-per-flight
11. Safety
  - o Range
  - o PAD
  - o Flight

RESPONSIBILITY  
NASA SAMSO

12. STS Performance  
o Orbiter  
o IUS

### STUDY PROJECT PLANNING FORM

<b>PARTICIPANT:</b> LtCol Tringali, Charles J. USAF	<b>ADVISOR:</b> Mr. R.K. McIntosh	<b>DATE:</b> November 1976										
<b>STUDY PROJECT TITLE:</b> OPERATIONS MANAGEMENT OF DOD SPACE MISSIONS IN THE SHUTTLE ERA												
<b>OVERALL PURPOSE OF PROJECT:</b> ( <u>What</u> plan to learn and <u>Why</u> ) To conduct an analysis and propose a solution to the problems of operations planning, payload integration, mission design and mission control during the era when the space shuttle becomes operational.												
<b>SPECIFIC STUDY PROJECT GOALS:</b> (to be achieved or questions to be answered) To develop an approach to future (post-1980) Space Transportation System (STS) operations which offers maximum inter-agency cooperation in DOD mission accomplishment with the NASA.												
<b>REPORT OPTION:</b> Formal Report												
<b>STUDY METHODS TO BE USED AND DATA SOURCES:</b> Congressional Records; DOD and DDR&E documents; HQ USAF and HQ NASA documents; Program office level documents from both agencies; interviews with STS operations and management personnel; critique of author's recommendations.												
<b>TENTATIVE OUTLINE OF PROJECT REPORT:</b> (Be as specific as possible) <ol style="list-style-type: none"> <li>1. <u>Introduction:</u> recent remarks of top DOD/USAF management; statement of report goals; scope and limitations.</li> <li>2. <u>History of the STS Program:</u> prior programs, program history since inception, current status, evolving roles and responsibilities.</li> <li>3. <u>DOD/USAF/NASA Interagency Interfaces:</u> SAMSO role; cooperation on contractual activities, relationships of the agencies; testimony to the Congress; formation of new joint-agency committees; DSARC activities.</li> <li>4. <u>STS Operations Issues:</u> payload operations requirements, operational concepts; security at mission control centers, attempts at resolution.</li> <li>5. <u>Considering the Future: A Recommendation:</u> a proposal for an approach to inter-agency space operations to make them responsive to national command authority. Appendices, Notes and Bibliography as required.</li> </ol>												
<b>KEY MILESTONES:</b> (Update as necessary.) <table style="width: 100%; margin-top: 10px;"> <tr> <td style="width: 60%;">Outline</td> <td style="text-align: right;">end week 4</td> </tr> <tr> <td>Data search complete</td> <td style="text-align: right;">end week 8</td> </tr> <tr> <td>Initial draft</td> <td style="text-align: right;">end week 11</td> </tr> <tr> <td>Critique/rewrite</td> <td style="text-align: right;">end week 12</td> </tr> <tr> <td>Report completed</td> <td style="text-align: right;">end week 14</td> </tr> </table>			Outline	end week 4	Data search complete	end week 8	Initial draft	end week 11	Critique/rewrite	end week 12	Report completed	end week 14
Outline	end week 4											
Data search complete	end week 8											
Initial draft	end week 11											
Critique/rewrite	end week 12											
Report completed	end week 14											
Progress review milestones: Weeks <u>5, 9, 11, 14</u> . (Include schedule to typist.)												

DEFENSE SYSTEMS MANAGEMENT SCHOOL

STUDY TITLE: OPERATIONS MANAGEMENT OF DOD SPACE MISSIONS IN THE SHUTTLE ERA

STUDY PROJECT GOALS:

To present a history of the DOD/USAF Space Shuttle program to date and recommend an approach to future government space operations which offers maximum interagency cooperation in DOD mission accomplishment with the NASA.

STUDY REPORT ABSTRACT:

This report presents a history of the development of the Space Transportation System (STS) to date between the National Aeronautics and Space Administration (NASA) and the executive agency acting for the Department of Defense, the United States Air Force. The STS consists of the NASA-developed space shuttle orbiter, the USAF-developed upper stage, the communications networks and launch base complexes of both agencies, and the satellite payloads developed by many user agencies to be placed in space. The program development is traced chronologically in terms of key joint-agency agreements, management interfaces, and compromises made as implementation of early proposals was accomplished.

A proposal is made to develop a joint-agency STS operations authority responsive to national command/policy channels.

Key Words: Future Space Operations; Joint-agency Management

NAME, RANK, SERVICE  
CHARLES J. TRINGALI, LtCol, USAF

CLASS  
PMC 76-2

DATE  
10 November 1976