

D-A038 832

CONSTRUCTION ENGINEERING RESEARCH LAB (ARMY) CHAMPAI--ETC F/G 13/8  
COATINGS AND CATHODIC PROTECTION OF PILINGS IN SEAWATER: RESULT--ETC(U)  
MAR 77 D E WITTMER, A KUMAR

UNCLASSIFIED

CERL-TR-M-207

NL

1 OF 1  
AD  
A038 832



END

DATE  
FILMED  
5-77

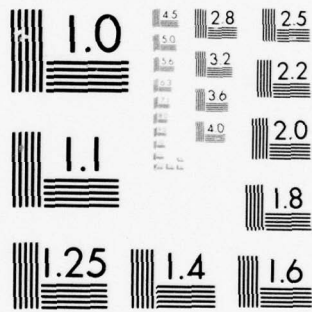

MICROCOPY RESOLUTION TEST CHART  
 NATIONAL BUREAU OF STANDARDS-1963-A

construction  
engineering  
research  
laboratory



TECHNICAL REPORT M-207  
March 1977

COATINGS AND CATHODIC PROTECTION OF PILINGS IN SEAWATER:  
RESULTS OF 5-YEAR EXPOSURE

AD A 038832

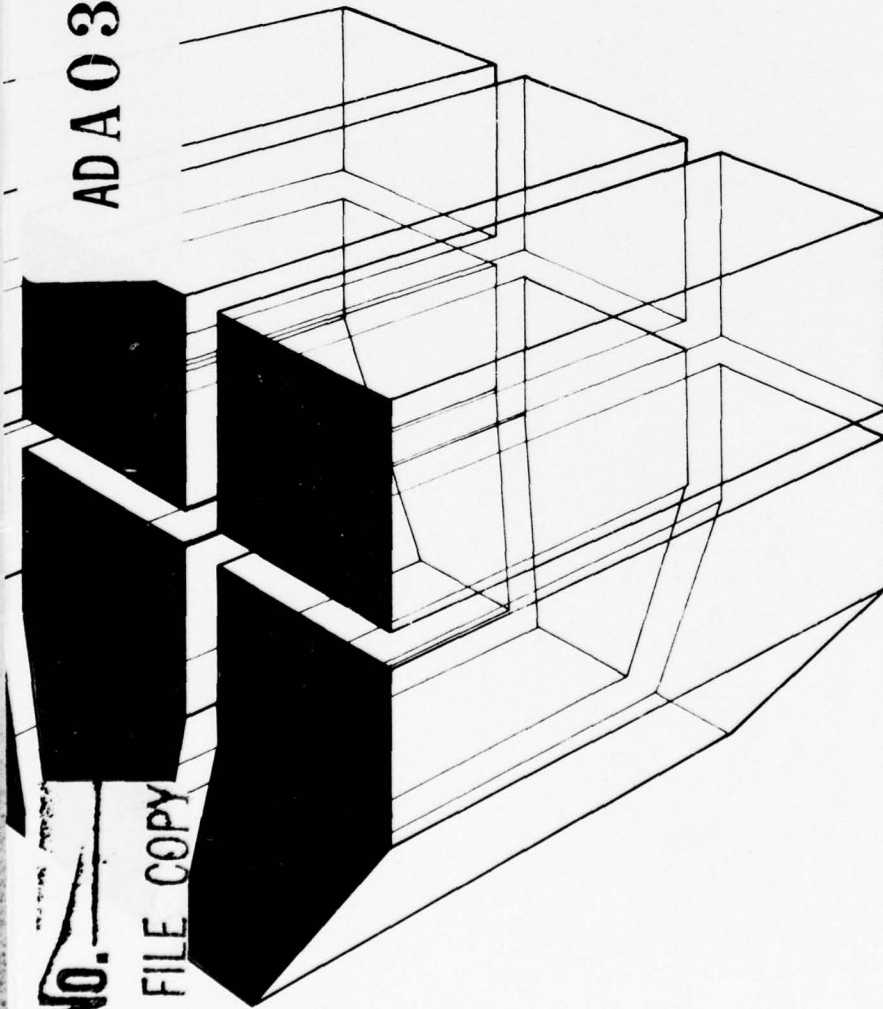

by  
D. E. Wittmer  
A. Kumar



AD No. \_\_\_\_\_  
DDC FILE COPY

The contents of this report are not to be used for advertising, publication, or promotional purposes. Citation of trade names does not constitute an official indorsement or approval of the use of such commercial products. The findings of this report are not to be construed as an official Department of the Army position, unless so designated by other authorized documents.

***DESTROY THIS REPORT WHEN IT IS NO LONGER NEEDED  
DO NOT RETURN IT TO THE ORIGINATOR***

SECURITY CLASSIFICATION OF THIS PAGE (When Data Entered)

| REPORT DOCUMENTATION PAGE   |  | READ INSTRUCTIONS<br>BEFORE COMPLETING FORM |  |
|---|--|---|--|
| 1. REPORT NUMBER<br>CERL-TR-M-2071  | 2. GOVT ACCESSION NO.  | 3. RECIPIENT'S CATALOG NUMBER<br>9          |  |
| 4. TITLE (and Subtitle)<br>COATINGS AND CATHODIC PROTECTION OF PILINGS IN SEAWATER: RESULTS OF 5-YEAR EXPOSURE  | 5. TYPE OF REPORT & PERIOD COVERED<br>FINAL rept. 5                          |   |  |
| 7. AUTHOR(s)<br>D. E. Wittmer<br>A. Kumar   | 8. CONTRACT OR GRANT NUMBER(s)   |   |  |
| 9. PERFORMING ORGANIZATION NAME AND ADDRESS<br>CONSTRUCTION ENGINEERING RESEARCH LABORATORY<br>P.O. Box 4005<br>Champaign, IL 61820   | 10. PROGRAM ELEMENT, PROJECT, TASK AREA & WORK UNIT NUMBERS<br>CWIS 31204 12 |   |  |
| 11. CONTROLLING OFFICE NAME AND ADDRESS   | 12. REPORT DATE<br>March 1977  | 13. NUMBER OF PAGES<br>80                   |  |
| 14. MONITORING AGENCY NAME & ADDRESS (if different from Controlling Office)   | 15. SECURITY CLASS. (of this report)<br>Unclassified                         |   |  |
| 16. DISTRIBUTION STATEMENT (of this Report)<br>Approved for public release; distribution unlimited.   |  |   |  |
| 17. DISTRIBUTION STATEMENT (of the abstract entered in Block 20, if different from Report)  |  |   |  |
| 18. SUPPLEMENTARY NOTES<br>Copies are obtainable from National Technical Information Service<br>Springfield, VA 22151   |  |   |  |
| 19. KEY WORDS (Continue on reverse side if necessary and identify by block number)<br>cathodic protection<br>corrosion<br>piling coatings   |  |   |  |
| 20. ABSTRACT (Continue on reverse side if necessary and identify by block number)<br>This report presents the results of the inspection of test pilings extracted after 5 years of exposure to seawater at LaCosta Island, FL. The effectiveness of various coating systems and sacrificial anodes in preventing corrosion of H- and steel pipe pilings in seawater is assessed. Six of the coating systems were found to perform excellently, as was a coating/cathodic protection combination. Sacrificial anodes of zinc and aluminum were also found to effectively reduce corrosion in the immersed zone. → over |  |   |  |

Block 20 continued.

The study also confirmed that use of the cathodic protection index and polarization behavior is an effective nondestructive testing technique for monitoring corrosion of steel immersed in seawater.

UNCLASSIFIED

## FOREWORD

This investigation was conducted for the Directorate of Civil Works, Office of the Chief of Engineers (OCE) under CWIS 31204 "Corrosion Mitigation in Civil Works Projects." Mr. J. Robertson is the OCE Technical Monitor. The work was performed by the Metallurgy Branch of the Materials and Science Division, U.S. Army Construction Engineering Research Laboratory (CERL).

Appreciation is expressed to Mr. L. Watkins, Mr. M. Dickey, and Mr. J. Lesnick (all of the Coastal Engineering Research Center) and Mr. H. Ardahl (retired from the Corps of Engineers Lower Mississippi Valley Division) for their assistance in the field inspections (1971 through 1974) and personal contacts. Appreciation is also extended to CERL personnel who participated in past inspections: Dr. R. Quattrone, Mr. C. Hahin, Mr. F. Kisters, Mr. J. Aleszka, Mr. G. Schnittgrund, Mr. M. Khobaib, Ms. R. Hannan, and Mr. B. Ching. Other CERL personnel participating in the study were Mr. R. Merritt, who assisted in the structure factor analysis, and Mr. S. Cato, who provided technical assistance. The assistance of Mr. W. Cannaday, CAPT J. Davis, and Mr. R. Cutter of the Corps of Engineers Tampa Bay Area Office, and Mr. A. Pelton of Need-a-Diver in Tampa, FL in the removal and preparation of the pilings for the 5-year inspection is also acknowledged.

Dr. A. Kumar is Chief of the Metallurgy Branch and Dr. G. R. Williamson is Chief of the Materials and Science Division. COL J. E. Hays is Commander and Director of CERL and Dr. L. R. Shaffer is Technical Director.

|                                 |               |                                     |
|---------------------------------|---------------|-------------------------------------|
| ACCESSION for                   |               |                                     |
| NTIS                            | White Section | <input checked="" type="checkbox"/> |
| DDC                             | Buff Section  | <input type="checkbox"/>            |
| UNANNOUNCED                     |               | <input type="checkbox"/>            |
| JUSTIFICATION.....              |               |                                     |
| BY.....                         |               |                                     |
| DISTRIBUTION/AVAILABILITY CODES |               |                                     |
| Dist.                           | Avail.        | and/or SPECIAL                      |
| A                               |               |                                     |

## CONTENTS

|  |           |
|--|-----------|
| DD FORM 1473   | 1         |
| FOREWORD   | 3         |
| LIST OF TABLES AND FIGURES                                       | 5         |
| <b>1 INTRODUCTION</b> .....                                      | <b>7</b>  |
| Background   |           |
| Objective  |           |
| <b>2 APPROACH</b> .....  | <b>7</b>  |
| Test Site  |           |
| Test Piles   |           |
| Annual Inspections   |           |
| Pile Removal   |           |
| Inspection of Removed Piles                                      |           |
| Pile Structure Factor  |           |
| <b>3 DISCUSSION OF RESULTS</b> .....                             | <b>18</b> |
| Visual Observations  |           |
| Pit Depth Measurements   |           |
| Pile Structure Factor  |           |
| Correlation of Visual and Structural Properties                  |           |
| Electrochemical Measurements                                     |           |
| <b>4 COST AND EFFECTIVENESS OF PROTECTION</b> .....              | <b>31</b> |
| <b>5 COMPARISON OF LACOSTA ISLAND AND DAM NECK SITES</b> .....   | <b>33</b> |
| Environmental Effects  |           |
| Comparison of Corrosion Rate Profiles and CPI                    |           |
| <b>6 CONCLUSIONS AND RECOMMENDATIONS</b> .....                   | <b>39</b> |
| Conclusions  |           |
| Recommendations  |           |
| <b>REFERENCES</b>  | <b>41</b> |
| <b>APPENDIX A: Photographs of Corrosion Damage to Steel</b>      |           |
| Pilings at LaCosta Island, FL                                    | <b>42</b> |
| <b>APPENDIX B: Charts of Corrosion Behavior of Steel Pilings</b> |           |
| at LaCosta Island, FL  | <b>48</b> |
| <b>APPENDIX C: Derivation of Pile Structure Factor</b>           | <b>77</b> |
| <b>DISTRIBUTION</b>  |           |

## TABLES

| Number  | Page |
|---|------|
| 1 Test Pile Details, LaCosta Island Test Site   | 10   |
| 2 Scale and Description of Rust Grades  | 16   |
| 3 Visual Evaluation of Coated Steel Piles, LaCosta Island Test Site                             | 19   |
| 4 Surface Factors for Uncoated and Cathodically Protected Steel Piles, LaCosta Island Test Site | 20   |
| 5 Pile Performance Based on Structure Factor  | 21   |
| 6 Correlation of Visual and Structural Characteristics  | 22   |
| 7 Potentials of Protected Piles With Respect to Copper-Copper Sulphate Half-Cell                | 23   |
| 8 Cathodic Protection Indices of the Pilings  | 25   |
| 9 Deterioration of Coating Systems  | 25   |
| 10 Polarization Data for LaCosta Island Pilings   | 25   |
| 11 Factors Affecting Total Cost of Coating New Steel Structures                                 | 31   |
| 12 Variables to Consider in Selecting Coating System  | 31   |
| 13 Relationship Between Cost and Effectiveness of Protection                                    | 32   |
| 14 <i>Summary of Results for LaCosta Island and Dam Neck Sites</i>                              | 34   |
| 15 Physical Characteristics of LaCosta Island and Dam Neck Sites                                | 37   |
| C1 Structural Properties and Associated Weighting Factors                                       | 79   |
| C2 Pile Structure Factors   | 80   |

## FIGURES

| Number  | Page |
|---|------|
| 1 LaCosta Island Test Site  | 8    |
| 2 Dimensions of H-Piles   | 9    |
| 3 Dimensions of Pipe Piles  | 9    |
| 4 Plan of LaCosta Island Test Piles   | 14   |
| 5 Elevation of Pile Set for LaCosta Island Test Site  | 15   |
| 6 Circuit Diagram for Measurement of Cathodic Protection Index and Polarization Measurements                        | 17   |
| 7 $\Delta I$ as a Function of Bare Steel Area in Tap and Salt Water   | 24   |
| 8 CPI as a Function of Time of Exposure for Organic Coating Systems   | 26   |
| 9 CPI as a Function of Time of Exposure for Miscellaneous Organic Coatings and Metal-Filled Organic Coating Systems | 26   |

## FIGURES (cont'd)

| Number |  | Page |
|--------|--|------|
| 10     | CPI as a Function of Time of Exposure for Organic Over Metal-Filled Coating Systems  | 27   |
| 11     | CPI as a Function of Time of Exposure for Metallic and Organic Over Metallic Systems | 27   |
| 12     | Polarization Curves for System 1   | 28   |
| 13     | Polarization Curves for System 7   | 29   |
| 14     | Polarization Curves for System 28  | 30   |
| 15     | Corrosion Profile of Bare Carbon Steel   | 35   |
| 16     | Corrosion Profile of Bare Mariner Steel  | 35   |
| 17     | Corrosion Profile of Cathodically Protected Bare Carbon Steel                        | 36   |
| 18     | Corrosion Profile of Coated, Cathodically Protected Piling                           | 36   |
| 19     | Corrosion Profile of Coal-Tar Epoxy Over Organic Zinc-Rich Primer                    | 37   |
| 20     | Pit Distribution for Zinc Anodes   | 38   |
| 21     | Pit Distribution for Aluminum Anodes   | 38   |
| 22     | Cathodic Protection Index as a Function of Corrosion Rate for LaCosta Island Pilings | 39   |
| 23     | Cathodic Protection Index as a Function of Corrosion Rate for Dam Neck Pilings       | 40   |
| 24     | Corrosion Rate vs. Corrosion Current   | 40   |
| A1     | LaCosta Island Piling Test Site  | 42   |
| A2     | Atmospheric Zone of Bare Carbon Steel with Zinc Anodes                               | 43   |
| A3     | Atmospheric Zone of Bare Carbon Steel with Aluminum Anodes                           | 43   |
| A4     | Coal-Tar Epoxy (C-200) on Carbon Steel   | 44   |
| A5     | Coal-Tar Epoxy (C-200) With Zinc Anodes  | 44   |
| A6     | Bare Carbon Steel with Zinc Anodes After 5-Year Removal                              | 45   |
| A7     | Bare Carbon Steel With Aluminum Anodes After 5-Year Removal                          | 45   |
| A8     | Typical Fouling in the Immersed Zone   | 46   |
| A9     | Aluminum-Pigmented Epoxy Tar After Sandblasting                                      | 46   |
| A10    | Epoxy Tar Over Zinc-Rich Primer After Sandblasting                                   | 47   |
| A11    | Polyester Glassflake   | 47   |

# COATINGS AND CATHODIC PROTECTION OF PILINGS IN SEAWATER: RESULTS OF 5-YEAR EXPOSURE

## 1 INTRODUCTION

### Background

The Directorate of Civil Works, Office of the Chief of Engineers, has jurisdiction over many structures, such as harbors, bridges, and buildings, which are supported on pilings in coastal areas. Steel pipe and H-pilings have generally been used for foundations in coastal areas; more recently, prestressed concrete pilings have also been used. However, designers of such structures are faced with a problem: quantitative data on the rate of piling corrosion and the performance of coatings and sacrificial anodes on steel pilings under long-term field exposures are not available.

In response to this problem, the U.S. Army Corps of Engineers and the National Bureau of Standards (NBS) initiated a corrosion study in 1967, when 31 sets of piles (three identical piles per set) were installed near Dam Neck, VA. Every 5 years, one row of piles was to be extracted and examined for corrosion damage. To determine the effect of geography and temperature, two more sites (LaCosta Island, FL and Buzzards Bay, MA) were selected by the Coastal Engineering Research Center (CERC), which evaluated the pilings through June 1974, when the inspection responsibility was transferred to the U.S. Army Construction Engineering Research Laboratory (CERL). The installation of 31 sets of three rows of piles at LaCosta Island was completed in January 1971, and annual inspections have been conducted since then. CERL installed the pilings at Buzzards Bay in October 1974 and conducted the first annual inspection in July 1975.<sup>1</sup>

### Objective

The objective of this study is to evaluate the effectiveness of various commercially available coatings and sacrificial anodes in preventing corrosion of pilings in seawater. This report summarizes the results of the inspection of test pilings extracted after 5 years of exposure at LaCosta Island, FL, and compares the results to those from the 5-year inspection of the Dam Neck, VA pilings.

<sup>1</sup>A. Kumar and C. Hahin, *First Annual Inspection of Buzzards Bay Pilings*, Technical Report M-172/ADA024381 (U.S. Army Construction Engineering Research Laboratory, [CERL], 1976).

## 2 APPROACH

### Test Site

Figure 1 shows the LaCosta Island test site. The yearly surface water temperature ranges from 55° to 90°F (13° to 32°C), with an approximate mean yearly temperature of 75°F (24°C). The salinity fluctuation due to tidal flushing in LaCosta Island is approximately 30 parts per thousand at low tide to 36 parts per thousand at high tide. Mean tide level at the LaCosta site is 1.3 ft (0.4 m) with a spring tide range of 2.6 ft (0.8 m). Wave action is light, and the bottom material is composed of approximately equal proportions by weight of silica sand and shell. In comparison, the bottom material at the Dam Neck site consists mostly of fine silica sand with a relatively thin layer of clay near the surface. This fine sand is easily carried into suspension by the surf, causing erosion-corrosion\* of the pile surfaces.

### Test Piles

The test piles included H- and pipe piles made of either American Society for Testing and Materials (ASTM) A 36 or ASTM 690 (mariner steel). The steel H piles are 6 in. X 6 in. X 30 ft (15.2 cm X 15.2 cm X 9.1 m) and weigh 25 lb/ft (37.2 kg/m). Stainless steel rods were welded between the inside flanges of each pile so that electrical contact could be made for electrochemical measurement. Figures 2 and 3 show the detail sections of the H- and pipe piles. Six prestressed concrete piles were also installed.

Some piles were installed without any coating or sacrificial anodes, while others have both coatings and cathodic protection. Most of the protective coating systems included in the LaCosta Island study are the same as those at the Dam Neck site. The systems include organic coatings, metallic coatings, organic over metallic, metal-filled organic, and organic over metal-filled. (See Table I for a complete list of the coatings and their sources.) The coatings were applied after the base metal was sandblasted to near "white metal" according to Steel Structures Painting Council (SSPC) Specification SSPC-SP-10-63T.

\*Erosion-corrosion is an accelerated attack on the metal due to the movement between the corrosive fluid and the metal surface. The corroding metal forms solid corrosion products which are swept away, revealing fresh metal for further corrosion. Although seashells are softer than steel, seashells (limestone) suspended in seawater will cause erosion-corrosion of steel piling.

The sacrificial anodes for the cathodically protected piles were mounted near the sand zone and consisted of zinc or aluminum. The zinc anodes are 4 × 4 × 36 in. (10.1 × 10.1 × 91.4 cm) and weigh about 150 lb (68.0 kg) when new; the aluminum anodes are 4 × 4 × 38 in. (10.1 × 10.1 × 96.7 cm) and weigh 60 lb (27.2 kg) when new. Two such anodes were installed on each pile to be cathodically protected.

The pilings were jetted into place in three rows parallel to the shoreline (Figures 4 and 5). The rows are designated A, B, and C, with row A being nearest the beach and row C farthest from the beach. Of the 31 sets of three piles, three are bare carbon or mariner steel, two are prestressed concrete, and the remaining are coated steel. Two of the coated steel pile sets are also cathodically protected. The coated piles in row A are completely coated; the coated B piles are entirely coated with the exception of seven 6 × 1 in. (15.2 × 2.5 cm) windows (at 2, 7, 14, 17, 20, 22, and 27 ft [0.6, 2.1, 4.3, 5.2, 6.1, 6.7, and 8.2 m] from the bottom of the pile on the piling surface facing the beach), and the C piles are completely coated, except for the embedded zone.

#### Annual Inspections

After placement, the pilings were subjected to five annual inspections consisting of visual observations and

electrochemical measurements. Visual observations included complete evaluation of coating deterioration in accordance with ASTM Standard Methods for Evaluating Degree of Rusting on Painted Steel Surfaces, D 610-68 (Table 2).

Three types of electrical measurements were taken: pile corrosion potential measurements, cathodic protection index measurements, and polarization measurements. Electrical contact with the stainless steel rods in the piles was made using vise clamps connected to the cable wires. The pile potential measurements were made on piles provided with sacrificial anodes to indicate the protection offered by the anodes. A Miller Model M-3-M Multimeter was used to measure the potential with respect to a copper-copper sulphate electrode buried in damp sand and shielded from the sun.

The cathodic protection indices (CPI) were determined for all coated piles except those with sacrificial anodes by forming a galvanic couple between two piles of a set and then measuring the potential with zero applied current. The current was then increased to lower the initial potential measured by 0.150 V for the metallic coated piles and 0.85 V for the other coated piles. The current was constantly adjusted to keep the lowered value of the potential constant during a 5-minute run. The initial and final values of the current and potential were then used to calculate the CPI value using Eq 1.

$$\text{CPI} = \Delta V / \Delta I \quad [\text{Eq 1}]$$

where  $\Delta V$  = change in voltage

$\Delta I$  = current required to shift the voltage.

The corrosion rate measurements were conducted by Schwerdtfeger and McDorman's<sup>2</sup> "polarization break" method, which uses breaks in the anodic and cathodic polarization curves to identify the corrosion rate via a calculated corrosion current,  $I_c$ .  $I_c$  can be calculated from the following relationship, which was derived by Pearson<sup>3</sup> and confirmed by Holler:<sup>4</sup>

$$I_c = (I_p)(I_q) / (I_p + I_q) \quad [\text{Eq 2}]$$

<sup>2</sup>W. J. Schwerdtfeger and O. N. McDorman, *Journal of the Electrochemical Society*, Vol 99 (1952), p 407.

<sup>3</sup>J. M. Pearson, *Transactions of the Electrochemical Society*, Vol 81 (1942), p 485.

<sup>4</sup>H. D. Holler, *Journal of the Electrochemical Society*, Vol 97 (1950), p 277.

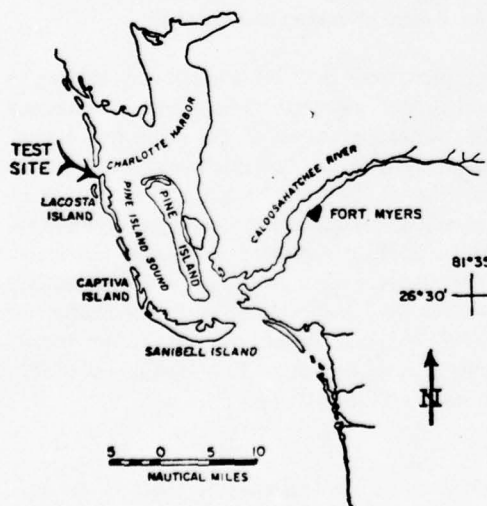

Figure 1. LaCosta Island test site. SI conversion factor: 1 nautical mile = 1.852 km.

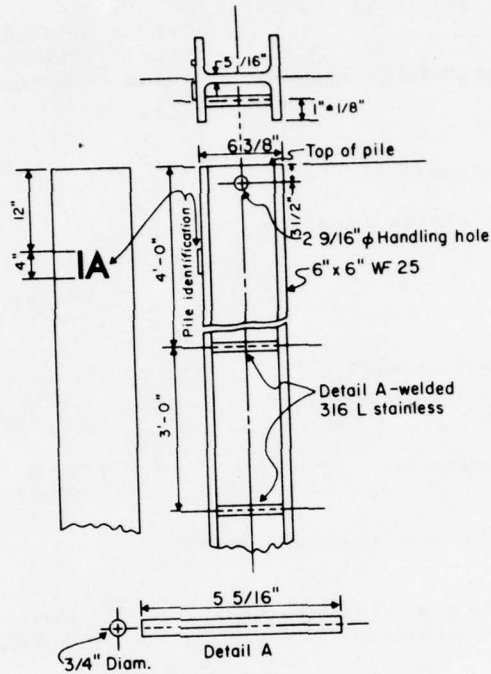

Figure 2. Dimensions of H-piles. SI conversion factors: 1 in. = 2.54 cm; 1 ft = 0.3048 m.

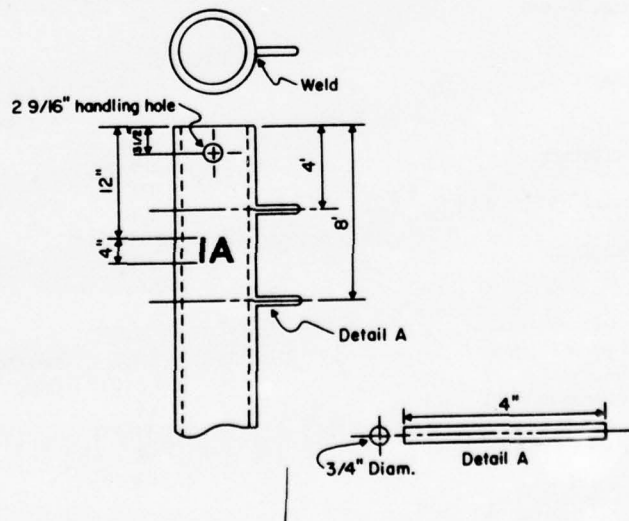

Figure 3. Dimensions of pipe piles. SI conversion factor: 1 in. = 2.54 cm.

Table 1

Test Pile Details, LaCosta Island Test Site

| System No. | Type of Piling* | Description of Coating System   | No. of Coats | Dry Coating Thickness, mils** (mm) | Coating Source                            | Remarks   |
|------------|-----------------|---|--------------|------------------------------------|---|---|
| 1          | H               | Bare carbon steel   | -            | -                                  | -   | -   |
| 2          | H               | Bare carbon steel with zinc anodes  | -            | -                                  | -   | 2 anodes  |
| 3          | H               | Bare carbon steel with aluminum anodes  | -            | -                                  | -   | 2 anodes  |
| 4          | H               | Coal-tar epoxy<br>Formula C-200   | 2            | 16-20<br>(0.41-0.51)               | United States Steel (U.S.S.)<br>Chemicals | -   |
| 5          | H               | Coal-tar epoxy with zinc anodes<br>Formula C-200, polyamide-cured             | 2            | 16-20<br>(0.41-0.51)               | U.S.S.<br>Chemicals                       | 2 anodes  |
| 6          | H               | Coal-tar epoxy, amine-cured<br>Tarsset  | 2            | 16-20<br>(0.41-0.51)               | U.S.S.<br>Chemicals                       | -   |
| 7          | H               | Coal-tar epoxy, aluminum-oxide-armored at mud line<br>Formula C-200           | 2            | 16-20<br>(0.41-0.51)               | U.S.S.<br>Chemicals                       | Third coat +<br>garnet to be ap-<br>plied between 11<br>and 17 ft (3.3<br>and 5.2 m) from<br>bottom of pile |
|            |                 | Formula C-200 + aluminum oxide (No. 30 grit)<br>broadcast into wet final coat | 1            | 10-11<br>(0.25-0.28)               |   |   |
| 8          | H               | Aluminum-pigmented epoxy-tar<br>Carbomastic #3                                | 1            | 8-9<br>(0.20-0.23)                 | Carboline<br>Co.                          | -   |
|            |                 | Carbomastic #12-14  | 1            | 7-8<br>(0.18-0.20)                 |   |   |
|            |                 | Carbomastic #5-140  | 1            | 4<br>(0.10)                        |   |   |
| 9          | H               | Coal-tar epoxy  |              |                                    | U.S.S.<br>Chemicals                       |   |
|            |                 | U.S.S. epoxy primer   | 1            | 3<br>(0.08)                        |   |   |
|            |                 | Tarsset Standard  | 1            | 8-10<br>(0.20-0.25)                |   |   |
|            |                 | Tarsset Standard  | 1            | 8-10<br>(0.20-0.25)                |   |   |
| 10         | H               | Epoxy over inorganic ceramic<br>Plas-Chem Zinc-ite G primer                   | 1            | 3-4<br>(0.8-0.10)                  | Plas-Chem<br>Corp.                        |   |
|            |                 | Plas-Chem's Ceram-ite #101  | 1            | 5-6<br>(0.13-0.15)                 |   |   |
|            |                 | Plas-Chem's 2140 Z high build epoxy   | 1            | 7-8<br>(0.18-0.20)                 |   |   |

See footnotes at end of table, p 13.

Table 1 (Cont'd)

Test Pile Details, LaCosta Island Test Site

| System No. | Type of Piling* | Description of Coating System  | No. of Coats | Dry Coating Thickness, mils** (mm) | Coating Source                          | Remarks  |
|------------|-----------------|--|--------------|------------------------------------|---|--|
| 11         | H               | Epoxy over inorganic zinc primer<br>Zincor #11 primer  | 1            | 1-1.5<br>(0.03-0.04)               | Plas-Chem Corp.                         |  |
|            |                 | Chem-Pon 2310X Red   | 1            | 8-9<br>(0.20-0.23)                 |   |  |
| 12         | H               | Saran<br>Washcoat primer, Mil-P-15328B<br>(Formula 117)  | 1            | 0.4<br>(0.01)                      | Navy Stock                              | Alternate coat white and orange                  |
|            |                 | Formula 113/54; Mil-L-18389  | 7            | 6-7<br>(0.15-0.18)                 |   |  |
| 13         | H               | Aluminum, flame-sprayed (wire)   | 1            | 6<br>(0.15)                        | Metalweld, Metco, or other              | Steel wire flash bonding coat, 1 mil (0.03 mm)   |
| 14         | H               | Aluminum, flame-sprayed (wire)<br>vinyl topcoat<br>Flame-sprayed aluminum (wire)                         | 1            | 6<br>(0.15)                        | Metalweld, Metco, or other              | Steel wire flash bonding coat<br>1 mil (0.03 mm) |
|            |                 | Washcoat primer, Formula 117, MIL-P-15328B   | 1            | 0.4<br>(0.01)                      |   |  |
|            |                 | Alum. vinyl, Metcoscal-AV (Alum, Vinyl)  | 2            | 2<br>(0.05)                        |   |  |
| 15         | H               | Zinc, flame-sprayed, with saran topcoat<br>Steel wire flash bond coat                                    | 1            | 1<br>(0.03)                        | Metco Metal weld or other               |  |
|            |                 | Flame-sprayed zinc (wire)  | 1            | 6<br>(0.15)                        |   |  |
|            |                 | Saran, Formula 113/54, alternate white and orange; finish coat, white                                    | 7            | 6-7<br>(0.15-0.18)                 |   |  |
| 16         | H               | Zinc, flame-sprayed, with Navy vinyl topcoat, Flame-sprayed zinc (wire)<br>Washcoat primer, MIL-P-15328B | 1            | 6<br>(0.15)                        | Metco Metal weld or other<br>Navy Stock | Steel wire flash bonding coat, 1 mil (0.03 mm)   |
|            |                 |  | 1            | 0.4<br>(0.01)                      |   |  |
|            |                 | Vinyl red-lead, Formula 119, MIL-P-15929   | 5            | 4-5<br>(0.10-0.13)                 |   |  |
| 17         | H               | Phenolic Mastic<br>Phenoline 300 (orange)  | 1            | 8<br>(0.20)                        | Carboline Co.                           |  |
|            |                 | Phenoline 300 (gray) finish coat   | 1            | 8<br>(0.20)                        |   |  |
| 18         | H               | Coal-tar epoxy over organic zinc-rich<br>U.S.S. zinc-rich epoxy No. 110                                  | 1            | 3<br>(0.08)                        | U.S.S. Chemicals                        |  |
|            |                 | Coal-tar epoxy, C-200  | 2            | 12<br>(0.30)                       |   |  |

See footnotes at end of table, p 13.

Table 1 (Cont'd)

Test Pile Details, LaCosta Island Test Site

| System No. | Type of Piling* | Description of Coating System  | No. of Coats | Dry Coating Thickness, mils** (mm) | Coating Source      | Remarks  |
|------------|-----------------|--|--------------|------------------------------------|---------------------|--|
| 19         | H               | Vinyl over inorganic zinc-rich<br>U.S.S. zinc-rich No. 220                 | 1            | 3<br>(0.08)                        | U.S.S.<br>Chemicals |  |
|            |                 | U.S.S. high-build vinyl  | 1            | 7<br>(0.18)                        |                     |  |
| 20         | H               | Epoxy-polyamide over inorganic zinc-rich<br>Carbozinc #11                  | 1            | 3<br>(0.08)                        | Carboline<br>Co.    |  |
|            |                 | High-build epoxy polyamide 190 HB  | 2            | 12<br>(0.30)                       |                     |  |
| 21         | H               | Epoxy-tar over inorganic zinc-rich<br>Carbozinc #11                        | 1            | 3<br>(0.08)                        | Carboline<br>Co.    |  |
|            |                 | Carbomastic #14  | 1            | 8<br>(0.20)                        |                     |  |
| 22         | H               | Vinyl Mastic over inorganic zinc-rich<br>Dimetcote #3+D3 Curing Solution   | 1            | 3<br>(0.08)                        | Amercoat<br>Corp.   | Curing solution<br>to be removed<br>by fresh water<br>wash   |
|            |                 | #54 Tie Coat   | 1            | 1<br>(0.03)                        |                     |  |
|            |                 | Vinylmastic #87  | 1            | 10<br>(0.25)                       |                     |  |
| 23         | H               | Bare mariner steel   | -            | -                                  | -                   | -  |
| 24         | H               | Bare mariner steel with zinc anodes  | -            | -                                  | -                   | 2 anodes   |
| 25         | H               | Coal-tar epoxy on mariner steel<br>Formula C-200                           | 2            | 16-20<br>(0.41-0.51)               | U.S.S.<br>Chemicals | -  |
| 26         | Pipe            | Bare carbon steel  | -            | -                                  | -                   | -  |
| 27         | Pipe            | Coal-tar epoxy<br>Formula C-200  | 2            | 16-20<br>(0.41-0.51)               | U.S.S.<br>Chemicals |  |
| 28         | Pipe            | Coal-tar epoxy, garnet-armored at mud line<br>Formula C-200                | 2            | 16-20<br>(0.41-0.51)               | U.S.S.<br>Chemicals | Third coat and<br>aluminum oxide<br>to be applied be-<br>tween 11 and 17<br>ft (3.3 and 5.2 m)<br>from bottom of<br>pile |
|            |                 | Formula C-200 + aluminum oxide (#30 grit)<br>broadcast into wet final coat | 1            | 10<br>(0.25)                       |                     |  |

See footnotes at end of table, p 13.

Table 1 (Cont'd)

Test Pile Details, LaCosta Island Test Site

| System No. | Type of Piling*                            | Description of Coating System                     | No. of Coats | Dry Coating Thickness, mils** (mm) | Coating Source | Remarks  |
|------------|--|---|--------------|------------------------------------|----------------|--|
| 29         | H  | Polyester glassflake, Carboglas 1601, spray grade | 2            | 40<br>(1.02)                       | Carboline Co.  | Blast material to provide 3-4 mil (0.08-0.10 mm) surface profile |
| 30         | Concrete<br>10 in.<br>(25.4 cm)<br>square  | Prestressed Concrete                              |              |                                    |                |  |
| 31         | Concrete<br>10 in.<br>(25.4 cm)<br>octagon | Prestressed Concrete                              |              |                                    |                |  |

\* Steel H-piles are 30-ft (9.1 m) lengths of 6 in. X 6 in. (15.2 cm X 15.2 cm) wide flange (25 lb/ft [37.2 kg/m]) mild carbon steel. Systems 23, 24, and 25 are mariner steel H piles. Systems 26, 27, and 28 are pipe piles, mild carbon steel, 6 in. (15.2 cm) diameter, schedule 40, 0.280 in. (0.7 mm) wall thickness. Prestressed concrete piles are as stated in this column.

\*\* Film thickness tolerance per coat may be plus or minus 15 percent of given thickness per coat, except where a range is given.

GENERAL NOTES:

All surfaces were blast-cleaned to near-white metal prior to coating. Systems 28 and 29 were supplied in the near-white condition. Specimens were numbered A, B, or C, which corresponds to their position (A faces the shore, B in the center, and C faces the Gulf), and have a numeric prefix which designates in what manner they were coated.

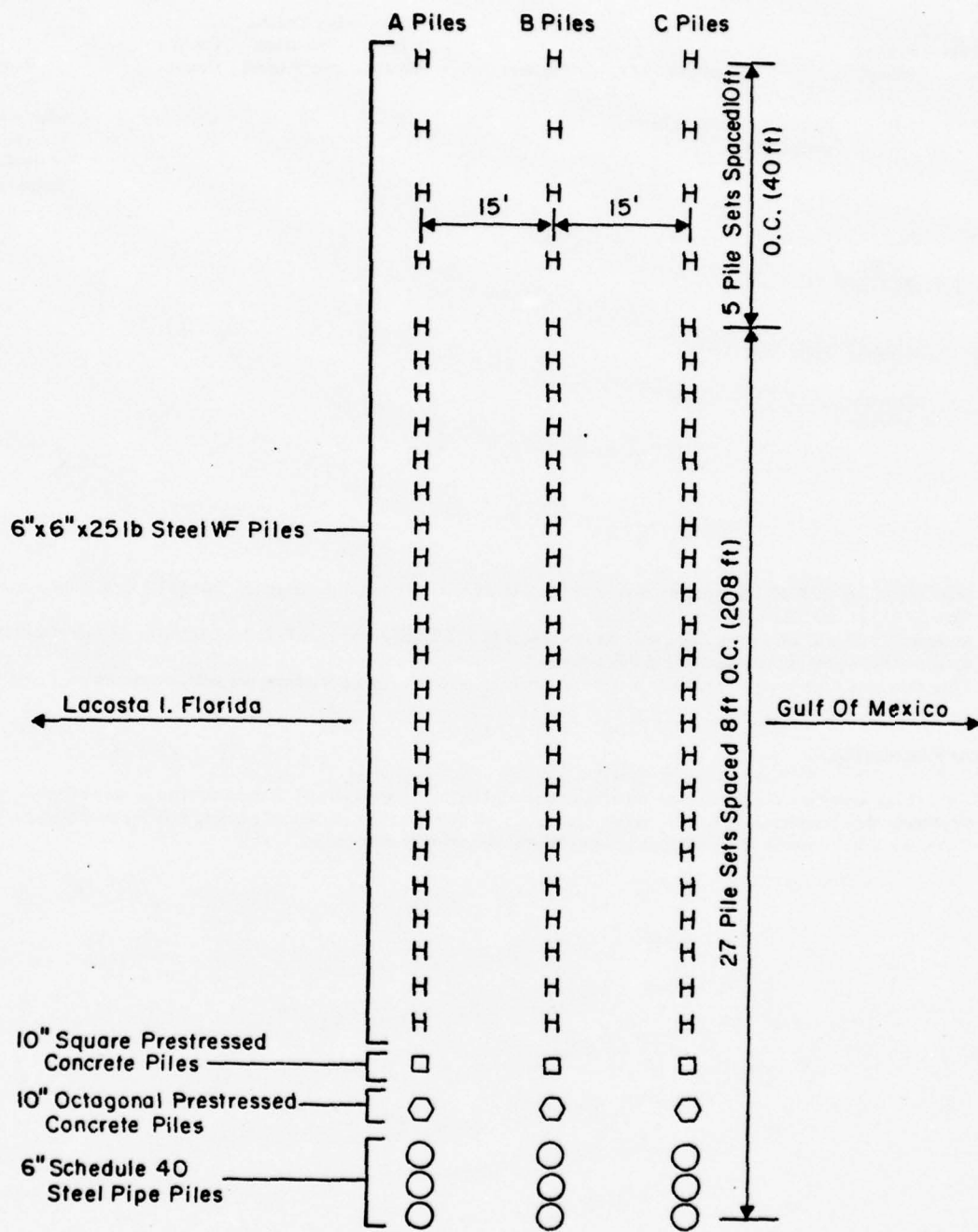

Figure 4. Plan of LaCosta Island test piles. SI conversion factors: 1 in. = 2.54 cm; 1 ft = 0.3048 m.

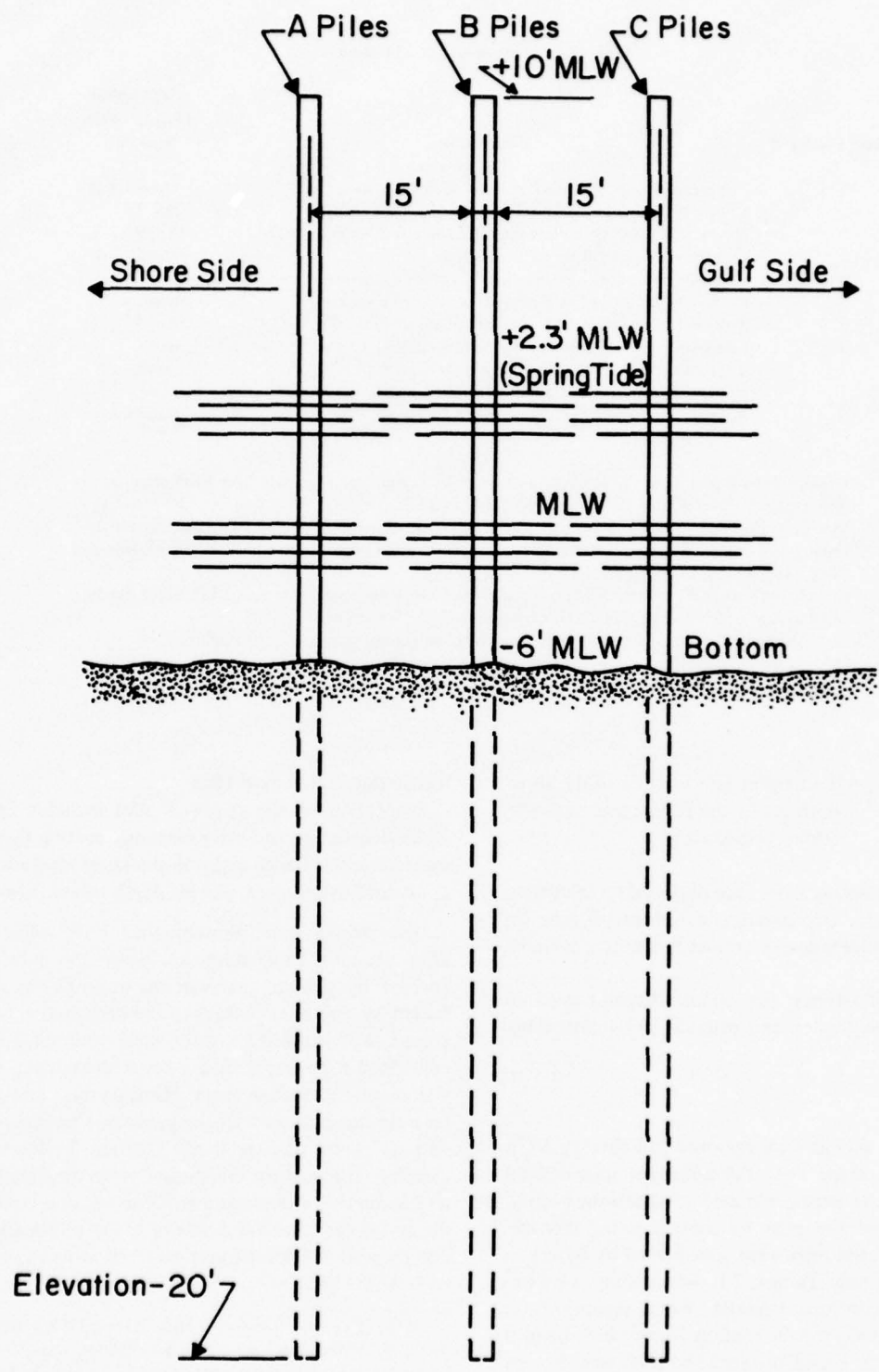

Figure 5. Elevation of pile set for LaCosta Island test site. SI conversion factor: 1 ft = 0.3048 m.

**Table 2**  
**Scale and Description of Rust Grades\***

| Rust Grades** | Description  | SSPC-ASTM<br>Photographic<br>Standard |
|---------------|--|---------------------------------------|
| 10            | No rusting or less than 0.01 percent of surface rusted           | unnecessary                           |
| 9             | Minute rusting, less than 0.03 percent of surface rusted         | No. 9                                 |
| 8***          | Few isolated rust spots, less than 0.1 percent of surface rusted | No. 8                                 |
| 7             | Less than 0.3 percent of surface rusted                          | none                                  |
| 6†            | Extensive rust spots but less than 1 percent of surface rusted   | No. 6                                 |
| 5             | Rusting to the extent of 3 percent of surface rusted             | none                                  |
| 4††           | Rusting to the extent of 10 percent of surface rusted            | No. 4                                 |
| 3†††          | Approximately one-sixth of the surface rusted                    | none                                  |
| 2             | Approximately one-third of the surface rusted                    | none                                  |
| 1             | Approximately one-half of the surface rusted                     | none                                  |
| 0+            | Approximately 100 percent of the surface rusted                  | unnecessary                           |

\* Reprinted with permission of American Society for Testing and Materials from *Evaluating Degree of Rusting on Painted Steel Structures*, ASTM D 610-68.

\*\* Similar to European Scale of Degree of Rusting for Anti-Corrosive Paints (1961) (black and white).

\*\*\* Corresponds to SSPC Initial Surface Conditions E (0 to 0.1 percent) and BISRA (British Iron and Steel Research Association) 0.1 percent.

† Corresponds to SSPC Initial Surface Conditions F (0.1 to 1 percent) and BISRA 1.0 percent.

†† Corresponds to SSPC Initial Surface Condition G (1 to 10 percent).

††† Rust grades below 4 are of no practical importance in grading performance of paints.

+ Corresponds to SSPC Initial Surface Condition H (50 to 100 percent).

where  $I_p$  and  $I_q$  = the tangent intersections of the linear portions of the anodic and cathodic curves, respectively.

These polarization curves are obtained by increasing the current from zero in equal increments of time (in this case 0.1-ampere increments at 5-minute intervals).

Figure 6 illustrates the circuit diagram used in making the polarization and cathodic protection index measurements.

#### Pile Removal

The row C pilings were removed in February 1976 by hooking a crane onto the pull-holes provided on the pilings. Water jetting was used to loosen the bottom material around the piles to prevent piling damage. After removal, the piles were transported by barges to a storage area near Tampa, FL, where they were unloaded onto concrete supports. Wood separators on the supports protected the coatings from being damaged by contact with a hard surface. The piles were spaced to allow easy access and room to turn the piles for inspection of all surfaces.

#### Inspection of Removed Piles

Inspection of the removed piles included coating evaluation before and after cleaning, coating thickness measurements, flange and web thickness measurements of all sandblasted piles, and pit depth measurements.

The pilings were photographed both before and after cleaning (Appendix A). Since the piles were covered by pelican guano in the atmospheric zone,\* fouled by marine organisms in the immersed zone, and coated with attached oyster shells and sand in the embedded zone, more than a conventional water wash was required to clean them. Hand-scraping and water-blasting removed most of the guano and marine fouling without severe damage to the coatings. Following the cleaning, the coating thicknesses were measured with an Elcometer, where possible. Charts were constructed displaying the corrosion behavior of the pilings (Appendix B), and the coated piles were rated in accordance with ASTM D 610-68.

\*For discussion purposes, each 30-ft (9.1 m) length of piling is divided into four zones: atmospheric zone (0 to 6 ft [0 to 1.8 m]), immersed zone (6 to 17 ft [1.8 to 5.2 m]), sand-swept zone (17 to 21 ft [5.2 to 6.4 m]), and embedded zone (21 to 30 ft [6.4 to 9.1 m]).

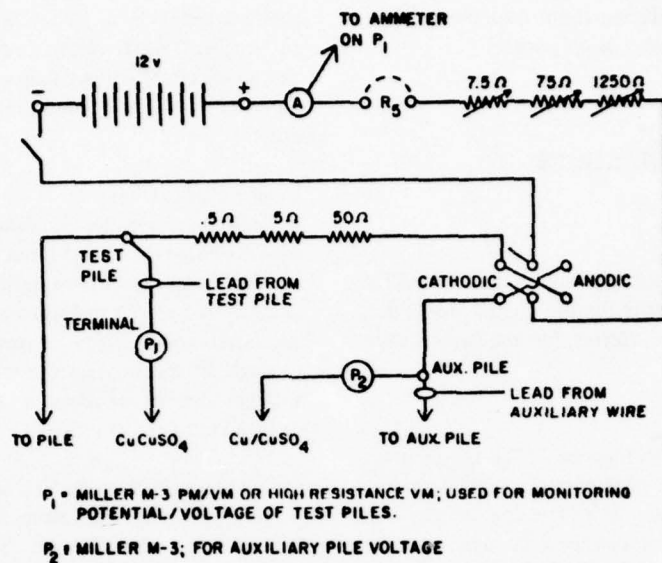

Figure 6. Circuit diagram for measurement of cathodic protection index and polarization measurements.

Sandblasting was required to permit measurement of metal thickness and determination of pit depth. As an alternative to the extensive sandblasting required to remove the attached oyster shells and sand from the buried zone, a conventional water-blaster capable of adding an abrasive to the water stream\* was used on some of the more stubborn fouling. Results indicated that this unit could be used for both the cleaning and coating-removal steps. It was cleaner, faster, and less polluting than sandblasting, and its capability of adding a rust inhibitor would prevent the piles from further rusting during the examination period. This would ensure that the surface examined would still be in the as-blasted condition.

Following the sandblasting operation, a pit depth profile was made for each of the piles containing pits, and flange and web thicknesses were determined along the lengths of the piles. The piles with the coatings removed were photographed to provide a visual record of pit shape, size, and distribution. The average corrosion

\*The unit used was the Aqua-Blaster manufactured by Partek Corp., Houston, TX and available from Boos Industrial Equipment, Tampa, FL.

rate was determined from the average web and flange thickness measurements. The pit depth data were also used in establishing surface factors for the pits according to type and distribution of damage.

#### Pile Structure Factor

The piles under examination were subjected only to stresses induced by current flow. Since there was no actual loading of the piles (as would be experienced in-service), there was no visible evidence of structural deterioration caused by diminishment of cross section due to corrosion or erosion-corrosion. However, since changes in pile dimensions could be measured, determining an estimated pile structure factor based on known changes in dimension and the condition of the pile surface was possible. Appendix C presents the derivation of a general expression that considers stresses involved in loading the piles based on the assumption that the upper part of the pile is the point of attachment.

Basically, the pile structure factor (PSF) is the product of a quantitative measurement of the pile section based on corrosion measurements and a qualitative assessment of the pile surface. The calculation of a

PSF permits ranking of piles according to their structural performance and placing them into one of four categories—excellent, good, fair, or poor.

### 3 DISCUSSION OF RESULTS

#### Visual Observations

Table 3 presents the surface factors and the ASTM D 610-68 evaluation results for the coated steel piles. Table 4 gives the surface factors for the cathodically protected and bare piles.

#### Organic Coatings

Most of the damage to the coal-tar epoxy coatings occurred in the immersed zone due to attack by marine organisms (especially barnacles). The coal-tar coatings held up very well in the sand-swept zone, where marine organisms could not attach themselves to the pile due to the abrasiveness of the sand-sea water slurry. This abrasion was not great enough to cause significant damage to the coatings, and no erosion-corrosion was noted.

System 9, a coal-tar epoxy over an epoxy primer, gave better protection than coal-tar epoxy alone, as expected; this was demonstrated by the undamaged surface observed after coating removal. System 7, a coal-tar epoxy with an alumina armor in the sand-swept zone, also showed no significant surface damage on coating removal. Coal-tar performed better on mariner steel than on carbon steel. The surface factors show that the polyamide-cured Formula C-200 (system 4) provided better protection than the Tarsel (system 6) in the immersed zone, while the harder Tarsel gave better abrasion resistance than the C-200 in the sand-swept zone.

The saran (polyvinylidene chloride) coating (system 12) gave excellent protection in the atmospheric and sand-swept zones, but was completely removed in the immersed (marine-fouled) zone. Upon coating removal, the pile surface was irregular and had many continuous shallow pits in the immersed zone.

The phenolic mastic coating (system 17) was somewhat damaged in the atmospheric and immersed zones, but held up excellently in the sand-swept zone. Upon coating removal, only slight damage was noted on the flanges in the atmospheric zone.

The polyester glassflake coating (system 29) gave the best results of any coating in the entire study, with an excellent visual rating in all three evaluated zones and an excellent surface factor. The marine fouling was removed very easily, and no significant damage was present.

#### Metal-Filled Coatings

Only system 8, an aluminum-pigmented epoxy-tar, was classified as metal-filled. This coating held up excellently in the atmospheric and sand-swept zones, but suffered severe rusting, staining, and pitting in the immersed zone. Upon coating removal, the surface throughout the immersed zone was found to contain a large number of deep pits, as evidenced by the surface factor rating of 3.

#### Organic Over Metal-Filled Systems

Seven coatings with electrically insulating top coats fell into this classification. System 10, a high-build epoxy over a zinc-rich primer, gave excellent protection in all three zones; there was no indication of significant corrosion damage. System 20, another high-build epoxy over zinc-rich primer, gave excellent protection in the atmospheric and immersed zones, but was almost completely removed in the sand-swept zone. After coating removal, the pile surface showed some pitting in the sand-swept zone, with isolated pits on the faces and edges of the flanges.

The coal-tar epoxy over zinc-rich primer (system 18) exhibited excellent protection in the atmospheric and sand-swept zones, but performed poorly in the immersed zone. However, on coating removal, the metal surface was essentially undamaged—an indication that the primer was effective although the visual rating of the coating indicated otherwise.\*

High-build vinyl (system 19) and epoxy over zinc-rich primer (system 11) indicated fair to excellent protection in all but the immersed zone, where removal of the coating again revealed that the metal surface was not severely damaged. The epoxy system showed somewhat greater damage in the immersed zone, with a roughened surface and a few pits.

\*This often happens in visual ratings of two-or-more-coat systems over primers or metallized coatings. Breakdown of the surface coating allows corrosion products to appear on the surface, thus giving an apparently lower visual rating. On coating removal, the metal surface is found to be essentially undamaged, in direct contradiction to the visual rating.

Table 3

Visual Evaluation\* of Coated Steel Piles,  
LaCosta Island Test Site

| System Class                             | System Type                     | System Number | Zone Evaluated |          |            | Average | Surface Factor** |
|--|---------------------------------|---------------|----------------|----------|------------|---------|------------------|
|  |                                 |               | Atmospheric    | Immersed | Sand-Swept |         |                  |
| Organic                                  | Coal-tar epoxy                  | 9             | 10             | 8        | 10         | 9.33    | 10               |
|  |                                 | 7             | 6              | 8        | 10         | 8.00    | 10               |
|  |                                 | 25            | 9              | 4        | 8          | 7.00    | 8                |
|  |                                 | 6             | 7              | 3        | 10         | 6.87    | 5                |
|  |                                 | 4             | 9              | 4        | 7          | 6.33    | 7                |
|  | Saran                           | 12            | 10             | 0        | 10         | 6.67    | 6                |
|  | Phenolic mastic                 | 17            | 7              | 8        | 10         | 8.33    | 9+               |
|  | Polyester glassflake            | 29            | 10             | 10       | 10         | 10      | 10               |
| Metal-filled                             | Aluminum-pigmented epoxy-tar    | 8             | 9              | 3        | 10         | 7.33    | 3                |
| Organic over metal-filled                | Zinc-rich primer                | 18            | 9              | 6        | 10         | 8.33    | 10               |
|  |                                 | 10            | 10             | 9        | 10         | 9.67    | 10               |
|  |                                 | 20            | 10             | 9        | 2          | 7.00    | 8                |
|  |                                 | 19            | 7              | 1        | 10         | 6.00    | 9                |
|  |                                 | 11            | 6              | 1        | 9          | 5.33    | 8                |
|  |                                 | 21            | 9              | 1        | 3          | 4.67    | 4                |
|  |                                 | 22            | 7              | 2        | 3          | 4.00    | 6                |
| Metallic                                 | Flame-sprayed, Al               | 13            | 7              | 8        | 5          | 6.67    | 10               |
| Organic over metallic                    | Vinyl (Al)                      | 14            | 8              | 7        | 3          | 6.00    | 10               |
|  |                                 | (Zn)          | 16             | 10       | 8          | 3       | 7.00             |
|  | Saran (Zn)                      | 15            | 5              | 1        | 3          | 3.00    | 8                |
| Organic coating with cathodic protection | Coal-tar epoxy with zinc anodes | 5             | 10             | 9        | 10         | 9.67    | 10               |
|  |                                 | 25            | 9              | 4        | 8          | 7.00    | 9                |

\*Visual Ratings Based on ASTM D 610-68.

\*\*Surface factor based on the condition of the pile after blast cleaning, according to type and distribution of damage. A rating of 10 indicates surface undamaged and a rating of 1 indicates severe surface damage that could result in structural failure.

**Table 4**

**Surface Factors for Uncoated and Cathodically Protected Steel Piles, LaCosta Island Test Site**

| System Class           | System Type     | System Number | Surface Factor |
|------------------------|-----------------|---------------|----------------|
| Bare piles             | Carbon steel    | 1             | 2              |
|                        |                 | 26            | 2              |
|                        | Mariner steel   | 23            | 4              |
| Cathodically protected | Zinc anodes     | 2             | 4              |
|                        |                 | 24            | 7              |
|                        | Aluminum anodes | 3             | 3              |

The last two systems in this classification gave poor performances in the immersed and sand-swept zones. System 21 (epoxy-tar over zinc-rich primer) performed very well in the atmospheric zone, resulting in good visual ratings during annual inspections; however, removal of the pile revealed extensive damage to the coating and pile surface. The immersed and sand-swept zones were severely pitted on all faces and flanges. The vinyl mastic over zinc-rich primer (system 22) provided only fair protection in the atmospheric zone, while the immersed and sand-swept zones received considerable damage. On coating removal, these two zones showed some surface damage in the form of a series of shallow interconnected pits on the faces and isolated pits on the edges of the flanges.

**Metallic Coatings**

Only system 13, a flame-sprayed aluminum, came under the metallic classification. Visually, this coating displayed significant rusting in all three zones, but on coating removal the surface was excellent, indicating that the sacrificial protection offered by the coating was still in operation.

**Organic Over Metallic Systems**

Vinyl was used as a coating for both flame-sprayed aluminum and zinc. Visually, the zinc (system 16) appeared to be providing better protection, but the aluminum-coated pile (system 14) showed a better surface on coating removal. Saran over flame-sprayed zinc (system 15) appeared to be giving very little protection, but on removal, the surface of the pile had

only been slightly damaged in the immersed and sand-swept zones.

**Organic Coating With Cathodic Protection**

Coal-tar epoxy with zinc anodes was used on both carbon (system 5) and mariner (system 25) steels. The system provided better protection to the carbon steel than the mariner steel, especially in the immersed zone. The carbon steel surface was virtually undamaged, while the mariner steel had some slight roughening in the immersed zone.

**Uncoated Piles**

The bare piles (both unprotected and protected) were rated to obtain a surface factor to be used in the structural analysis (Table 4). As the table indicates, only the mariner steel with zinc anodes provided better than a poor surface. The other bare piles were corroded severely in the atmospheric zone, with less corrosion in the immersed zone. Corrosion was minimal and no evidence of pitting was present on the cathodically protected piles. Because the anodes protect against corrosion only in the immersed section of the piles (the salt water acts as a medium for electron exchange), the air-exposed portion (atmospheric zone) is free to corrode. This is the zone where significant corrosion occurred. The bare mariner steel provided somewhat better protection than the bare carbon steel, which was severely pitted and contained holes in the web.

**Pit Depth Measurements**

The pit depth data were used qualitatively in establishing the surface factors listed in Tables 3 and 4. This information is important in considering the structural degradation of pilings subjected to corrosion, but would be more useful if a procedure for determining pit density as a function of pit surface area and depth existed.

**Pile Structure Factor**

Table 5 lists pile performances based on the PSF according to the magnitude of the importance factor,  $k_2$ , which reflects the sensitivity of the PSF to surface condition. The magnification factor,  $k_1$ , is held constant at 0.1.\*

As Table 5a shows, the PSF is less sensitive to the large variations in surface condition (structural surface factor) when the importance factor is assigned a value

\*Appendix C describes the complete derivation of the structure factor equation, and details the definition of the importance and magnification factors.

of 0.5. With an importance factor of 1.0 (Table 5b), the PSF varies linearly with variations in the surface condition. With yet another increase in the importance factor ( $k_2$  equals 2.0, Table 5c), the PSF becomes very sensitive to small changes in surface condition.

The piles were ranked according to their calculated PSF and grouped into categories based on structure factor and surface condition. After considering the relationship between visual observations and PSF, the linear model (Table 5b) was chosen as the basis for evaluating the total effectiveness provided by each system. In all, seven piles were rated excellent, six good, five fair, and eight poor. Appendix C presents the complete results of the structure factor analysis, including the actual pile rankings and weighting, magnification, and importance factors.

#### Correlation of Visual and Structural Properties

Table 6 illustrates the correlation between the visual and structural characteristics of the steel pilings and gives a total view of the protection offered by each system. It indicates the weakest coated area and average coating evaluations based on ASTM D 610-68, the surface rating based on magnitude of surface factor, the structural rating (from Table 5b), and the overall effectiveness of the protection. The weakest coated area evaluation was included to point out that coatings can be rated as good overall but perform poorly in a particular area of importance. It also illustrates that the

surface coatings may be rated poor even though the piles are structurally sound due to sufficient primer or metallizing. The surface and coating characteristics were compared with the structural character of the system to determine the system's overall effectiveness.

#### Organic Coatings

In the organic coating class, the polyester glassflake (system 29) and C-200 coal-tar epoxy over epoxy primer (system 9) were found to be providing excellent protection. Coal-tar epoxy with aluminum oxide armor (system 7), coal-tar epoxy over mariner steel (system 25), and phenolic mastic (system 17) showed good protection. Coal-tar epoxy C-200 (system 4) gave fair protection, while Tarsel coal-tar (system 6) and saran (system 12) provided poor protection. For nearly all coatings in the organic class, the effectiveness of protection was primarily affected by coating (and hence steel) degradation in the immersed zone, where marine fouling damaged the coating and promoted corrosion.

#### Metal-Filled Coatings

The one system in the metal-filled class—the aluminum-pigmented epoxy-tar (system 8)—was rated as poor. This was a three-coat system in which two coats of epoxy-tar electrically insulated the outer coat containing the aluminum pigment from the metal. This system's mechanism for sacrificial protection depends on electron exchange between the pigment and the steel, which can come about only through a very slow diffusion mechanism; thus, the aluminum pigment cannot provide sacrificial protection. The coating was perforated by barnacles, which are suspected of causing the severe pitting in the immersed zone.

#### Organic Over Metal-Filled Systems

Overall, this class provided very good protection although visual analysis indicated only fair performance. This system's effectiveness depends on the capability of the metal-filled primers to provide sacrificial protection; the cover coat is a diffusion barrier. Epoxy over inorganic ceramic and zinc-rich primer (system 10) was rated excellent in all areas, while coal-tar epoxy over an organic zinc-rich (conductive) coating (system 18) provided excellent overall protection. High-build vinyl (system 20) and high-build epoxy (system 19) on inorganic zinc-rich primers were rated as good; epoxy (system 11) and vinyl (system 22) over zinc-rich primers were rated as fair; and epoxy-tar over an inorganic zinc-rich primer was rated poor. Again, most of the coating degradation leading to corrosion was in the immersed zone due to marine fouling.

Table 5

#### Pile Performance Based on Structure Factor

|                           |                              |
|---------------------------|------------------------------|
| a. $k_1 = 0.1, k_2 = 0.5$ |                              |
| Excellent                 | — 29, 18, 10, 14, 5, 9, 13   |
| Good                      | — 24, 7, 16, 25, 17          |
| Fair                      | — 20, 15, 4, 22, 19, 6       |
| Poor                      | — 21, 8, 11, 12, 2, 3, 23, 1 |
| b. $k_1 = 0.1, k_2 = 1.0$ |                              |
| Excellent                 | — 29, 18, 10, 14, 5, 9, 13   |
| Good                      | — 7, 16, 25, 17, 20, 15      |
| Fair                      | — 24, 4, 22, 19, 6           |
| Poor                      | — 21, 8, 11, 12, 2, 3, 23, 1 |
| c. $k_1 = 0.1, k_2 = 2.0$ |                              |
| Excellent                 | — 29, 18, 20, 10, 15         |
| Good                      | — 7, 16, 14, 25, 17, 5, 9    |
| Fair                      | — 13, 4, 22, 24, 6, 19       |
| Poor                      | — 21, 8, 11, 12, 2, 23, 3, 1 |

Table 6

## Correlation of Visual and Structural Characteristics\*

| System Class                             | System Type               | System Number                | Weakest Coated Area** | Coating Average† | Surface Factor | Structure Factor | Effectiveness of Protection |   |
|--|---------------------------|------------------------------|-----------------------|------------------|----------------|------------------|-----------------------------|---|
| Organic coatings                         | Coal-tar epoxy            | 9                            | G-I                   | E                | E              | E                | E                           |   |
|  |                           | 7                            | P-A                   | G                | E              | G                | G                           |   |
|  |                           | 25                           | P-I                   | G                | E              | G                | G                           |   |
|  |                           | 6                            | P-I                   | F                | P              | F                | P                           |   |
|  |                           | 4                            | P-I                   | F                | F              | F                | F                           |   |
|  | Saran                     | 12                           | P-I                   | F                | P              | P                | P                           |   |
|  | Phenolic mastic           | 17                           | G-A                   | G                | E              | G                | G                           |   |
|  | Polyester glassflake      | 29                           | E                     | E                | E              | E                | E                           |   |
|  | Metal-filled              | Aluminum-pigmented epoxy tar | 8                     | P-I              | G              | P                | P                           | P |
|  | Organic over metal-filled | Zinc-rich primers            | 18                    | P-I              | G              | E                | E                           | E |
| 10                                       |                           |                              | E                     | E                | E              | E                | E                           |   |
| 20                                       |                           |                              | P-S                   | G                | G              | F                | G                           |   |
| 19                                       |                           |                              | P-I                   | F                | E              | F                | G                           |   |
| 11                                       |                           |                              | P-I                   | P                | G              | P                | F                           |   |
| 21                                       |                           |                              | P-I, S                | P                | P              | P                | P                           |   |
| 22                                       |                           |                              | P-I, S                | P                | G              | P                | F                           |   |
| Metallic                                 | Flame-sprayed Al          | 13                           | P-S                   | F                | E              | E                | E                           |   |
| Organic over metallic                    | Vinyl (Al)                | 14                           | P-S                   | F                | E              | E                | E                           |   |
|  | (Zn)                      | 16                           | P-S                   | F                | E              | G                | G                           |   |
|  | Saran (Zn)                | 15                           | P-I, S                | P                | G              | F                | F                           |   |
| Organic coating with cathodic protection | Coal-tar epoxy            | 5                            | E                     | E                | E              | E                | E                           |   |
|  | with zinc anodes          | 25                           | P-I                   | G                | E              | G                | G                           |   |
| Cathodically protected                   | Zinc anodes               | 2                            | -                     | -                | P              | P                | P                           |   |
|  |                           | 24                           | -                     | -                | G              | F                | F                           |   |
|  | Aluminum anodes           | 3                            | -                     | -                | P              | P                | P                           |   |
| Bare piles                               | Carbon steel              | 1                            | -                     | -                | P              | P                | P                           |   |
|  |                           | 26                           | -                     | -                | P              | -                | -                           |   |
|  | Mariner steel             | 23                           | -                     | -                | P              | P                | P                           |   |

\*Ratings: E = Excellent, G = Good, F = Fair, P = Poor.

\*\*Area of coating suffering the most damage - A = Atmospheric, I = Immersed, S = Sand-swept.

†Rating based on performance in all zones.

### Metallic Coatings

Flame-sprayed aluminum (system 13), which was the only metallic coating without a cover coat, was found to provide excellent protection in spite of its only fair visual performance.

### Organic Over Metallic Systems

Overall, this classification is rated very good. In the vinyl system, the aluminum flame-sprayed provided better protection than the zinc flame-sprayed system. The saran over zinc flame-sprayed system was only fair. These performances suggest that the sacrificial protection offered by the flame-sprayed metals is still operative after 5 years immersion, with aluminum providing better protection than zinc.

### Organic Coatings with Cathodic Protection

The very effective protection offered by the coal-tar epoxy zinc anode combinations (systems 5 and 25) indicates that an organic coating coupled with cathodic protection provides an effective means of protecting the exposed portion of the piling, as well as cathodically protecting the immersed section should any break in the coating occur.

### Uncoated Piles

The unprotected steel piles failed due to severe rusting in the atmospheric zone. When cathodically protected, the air-exposed part of the steel corroded severely, since the sacrificial anodes are only operative in the salt water. The mariner steel performed well enough in the atmospheric zone to be classified as fair overall.

### Electrochemical Measurements

#### Potential Measurements

The potentials of the protected piles (Table 7) were measured with respect to a copper-copper sulphate half-cell. The results of the 1972 and 1976 inspections show that no significant changes in potentials have occurred, although a slight trend toward higher cathodic potentials can be observed. These results indicate that the sacrificial anodes are providing protection in the immersed zone.

#### Cathodic Protection Index (CPI) Measurements

The CPI indicates the current required to cathodically protect the bare area in the immersed zone by determining the amount of current required to shift the potential of the pile in the cathodic direction by 150mV, or attain -0.85 V with respect to copper-copper sulphate electrode.

Table 7

Potentials of Protected Piles With Respect to Copper-Copper Sulphate Half-Cell

| Pile Number and Row | Inspection Results 1972 Voltage | Inspection Results 1976 Voltage | Nature of Coating                      |
|---------------------|---------------------------------|---------------------------------|--|
| 2 A                 | 1.080                           | 1.11                            | Bare carbon steel with zinc anodes     |
| B                   | 1.808                           | 1.05                            |  |
| C                   | 1.080                           | 1.10                            |  |
| 3 A                 | 0.990                           | 1.09                            | Bare carbon steel with aluminum anodes |
| B                   | 0.990                           | 1.05                            |  |
| C                   | 0.995                           | 1.05                            |  |
| 5 A                 | 1.080                           | 1.09                            | Coal-tar epoxy with zinc anodes        |
| B                   | 1.100                           | 1.10                            |  |
| C                   | 1.090                           | 1.09                            |  |
| 24 A                | 1.075                           | 1.10                            | Bare mariner steel with zinc anodes    |
| B                   | 1.080                           | 1.10                            |  |
| C                   | 1.080                           | 1.10                            |  |

Recent laboratory investigations of vinyl and coal-tar epoxy coatings and bare steel immersed in tap and salt water at CERL have demonstrated the direct correlation between change in current and change in bare steel area (Figure 7). Since CPI is inversely proportional to the change in current (by Eq 1), a direct correlation exists between CPI and bare steel exposed to an aqueous medium. A decrease in CPI is indicative of a larger area of bare steel exposed to water (larger change in current required); a decrease in CPI is therefore an indication of coating deterioration.

Figure 7 also demonstrates the need for higher currents for cathodic protection in salt water, which is more corrosive than tap or fresh water; thus, the magnitude of the CPI also depends on the test or service environment.

Table 8 shows the CPI for the 1972 through 1976 pile measurements. The 5 years of data show CPI vs time of exposure as a straight line on log-log coordinates, indicating that the CPI follows a relation of the type:

$$\text{CPI} = Kt^m + C_0 \quad [\text{Eq 3}]$$

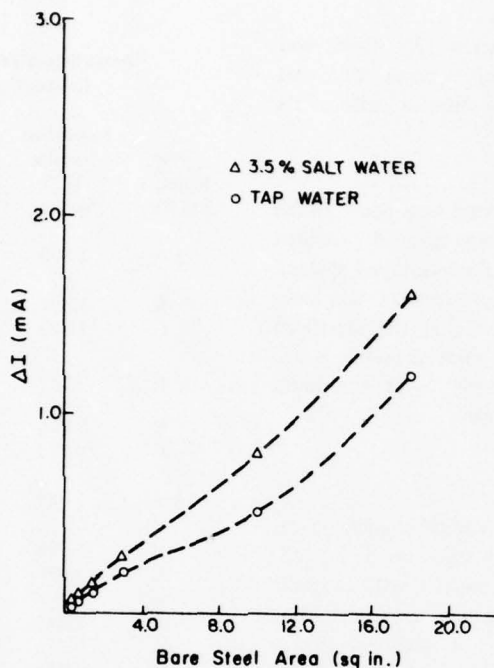

Figure 7.  $\Delta I$  as a function of bare steel area in tap and salt water. SI conversion factor: 1 sq in. = 6.4156 cm<sup>2</sup>.

where  $m \sim -0.65$ , with values ranging from +1.688 to -1.890 (indicates rapidity of decay of coating effectiveness)

$K$  = ordinate intercept at  $\log t = 1$   
 $C_0$  = constant at  $t$  (initial CPI at immersion)  
 $t$  = time of exposure.

Plotting the cathodic protection indices vs. time durations on log-log plots (Figures 8 through 11) permits prediction of the deterioration of the coatings over a long period of time. Deterioration of the coatings generally resulted in a drop in CPI, as demonstrated by a negative slope averaging approximately -0.65 for all coatings (Figures 8 through 10). However, some coatings, such as flame-sprayed metalics, have a completely flat slope or a slightly positive one, indicating formation of protective corrosion products, such as aluminum oxide or zinc oxide, in the porous flame-sprayed metal. All other systems show negative logarithmic behavior, with decay of index  $m$  depending

on the coating and mil thickness. Slopes for piles with and without windows are the same for each particular coating, but the absolute values of the CPIs of piles with windows are always lower.

Table 9 summarizes the values of the exponent  $m$ , which measures the rapidity of decay of coating effectiveness.

Comparison of Table 6 and Figures 8 through 11 shows a very strong correlation between the rank of the effectiveness of protection and CPI for all independent generic systems. Only in the category of organic over metal-filled coatings is the correlation weakened, possibly because of the difference in conductivity of the various metal-filled undercoats.

#### Polarization Measurements

The corrosion rate or rate of metal loss can be determined from the average corrosion current density: the higher the corrosion current density, the higher the

Table 8

Cathodic Protection Indices of the Pilings\*  
(V/A)

| Pile Number and Row | 1972  | 1973  | 1974 | 1975  | 1976  |
|---------------------|-------|-------|------|-------|-------|
| 4A                  | 8.95  | 3.61  | 1.6  | 1.14  | 1.72  |
| 4B                  | 2.38  | 1.72  | 1.1  | 0.71  | 1.63  |
| 6A                  | 7.00  | 2.21  | 1.3  | 0.76  | 1.54  |
| 6B                  | 1.45  | 0.930 | 0.68 | 0.59  | 1.89  |
| 7A                  | 13.0  | 9.10  | 7.2  | 5.67  | 5.06  |
| 7B                  | 3.02  | 2.46  | 2.0  | 1.98  | 2.43  |
| 8A                  | 21.7  | 3.76  | 1.7  | 0.92  | 1.72  |
| 8B                  | 2.48  | 1.48  | 1.1  | 0.59  | 4.59  |
| 9A                  | 19.7  | 15.5  | 1.1  | 8.42  | 7.23  |
| 9B                  | 1.97  | 1.94  | 1.6  | 1.46  | 2.11  |
| 10A                 | 4.17  | 3.26  | 2.4  | 0.23  | 0.37  |
| 10B                 | 4.02  | 4.55  | 3.8  | 4.17  | 3.26  |
| 11A                 | 0.303 | 0.139 | 0.12 | 0.11  | 1.37  |
| 11B                 | 0.257 | 0.137 | 0.11 | 0.11  | 1.30  |
| 12A                 | 0.271 | 0.162 | 0.12 | 0.11  | 1.40  |
| 12B                 | 0.510 | 0.228 | 0.15 | 0.13  | 1.36  |
| 13A                 | 3.85  | 5.17  | 5.4  | 4.69  | 4.59  |
| 13B                 | 3.66  | 5.12  | 5.7  | 6.00  | 5.00  |
| 14A                 | 6.45  | 3.23  | .2   | 13.64 | 16.30 |
| 14B                 | 4.20  | 5.36  | 5.6  | 7.50  | 5.25  |
| 15A                 | 0.518 | 0.794 | .81  | 1.13  | 2.34  |
| 15B                 | 0.426 | 0.593 | .75  | 1.07  | 2.54  |
| 16A                 | 0.728 | 0.893 | 1.5  | 2.11  | 3.49  |
| 16B                 | 0.987 | 0.938 | .13  | 1.97  | 4.69  |
| 17A                 | 11.3  | 4.11  | 2.9  | 1.47  | 2.04  |
| 17B                 | 2.27  | 1.88  | 1.3  | 1.03  | 1.74  |
| 18A                 | 34.2  | 17.4  | 10   | 6.30  | 0.46  |
| 18B                 | 2.47  | 2.2   | 1.6  | 1.30  | 1.91  |
| 19A                 | 2.18  | 0.327 | 0.21 | 0.19  | 1.50  |
| 19B                 | 0.975 | 0.282 | 0.17 | 0.16  | 1.32  |
| 20A                 | 70.8  | 46.9  | 21   | 23.08 | 16.85 |
| 20B                 | 2.63  | 2.73  | 3.7  | 4.05  | 5.67  |
| 21A                 | 53.6  | 39.0  | 24   | 48.39 | 16.00 |
| 21B                 | 2.05  | 1.41  | 0.65 | 0.35  | 1.35  |
| 22A                 | 1.98  | 2.13  | 0.32 | 0.18  | 1.34  |
| 22B                 | 2.79  | 2.03  | 0.50 | 0.27  | 1.33  |
| 25A                 | 15.4  | 5.00  | 1.7  | 1.07  | 18.91 |
| 25B                 | 2.52  | 1.53  | 0.78 | 0.62  | 1.74  |
| 26A                 |       |       |      |       |       |
| 26B                 |       |       |      |       |       |
| 27A                 | 7.87  | 5.30  | 4.0  | 3.7   | 4.25  |
| 27B                 | 2.09  | 2.34  | 1.9  | 1.89  | 2.25  |
| 28A                 |       | 7.75  | 3.7  | 2.94  | 3.26  |
| 28B                 |       | 2.85  | 1.9  | 1.94  | 2.21  |
| 29A                 | 17.9  | 12.5  | 10   | 7.92  | 7.69  |
| 29B                 | 2.44  | 2.38  | 2    | 2.14  | 2.88  |

\*CPI =  $\Delta V / \Delta I$ 

where  $\Delta I$  = the current required to shift the voltage to -0.85 V with respect to a copper-copper sulphate half-cell  
 $\Delta V$  = the change in voltage.

Table 9

## Deterioration of Coating Systems

| Generic Classification                 | Coating System Code Number | Rapidity of Decay, m* |
|--|----------------------------|-----------------------|
| Coal-tar epoxy                         | 4                          | -1.800                |
| Coal-tar epoxy                         | 6                          | -1.716                |
| Coal-tar epoxy, aluminum-oxide-armored | 7                          | -0.571                |
| Coal-tar epoxy, aluminum-pigmented     | 8                          | -1.890                |
| Coal-tar epoxy, aluminum-pigmented     | 9                          | -0.543                |
| Coal-tar epoxy, organic zinc           | 18                         | -1.195                |
| Coal-tar epoxy, inorganic zinc         | 21                         | -0.637                |
| Coal-tar epoxy                         | 25                         | -1.890                |
| Coal-tar epoxy                         | 27                         | -0.577                |
| Epoxy, inorganic zinc                  | 10                         | -0.485                |
| Epoxy, inorganic zinc                  | 20                         | -0.834                |
| Epoxy, inorganic zinc                  | 11                         | -0.227                |
| Vinyl, inorganic zinc                  | 19                         | -0.655                |
| Vinyl mastic, inorganic zinc           | 22                         | -1.031                |
| Flame-sprayed aluminum                 | 13                         | +0.145                |
| Flame-sprayed aluminum, vinyl topcoat  | 14                         | +1.688                |
| Flame-sprayed zinc, saran topcoat      | 15                         | +0.543                |
| Flame-sprayed zinc, Navy vinyl         | 16                         | +0.782                |
| Phenolic mastic                        | 17                         | -1.476                |
| Saran, MIL-L-18389 primer              | 12                         | -0.818                |
| Polyester glassflake                   | 29                         | -0.576                |

\*Negative m indicates decay of the coating rating, whereas positive m indicates rating improvement.

Table 10

## Polarization Data for LaCosta Island Pilings

| Variable   | Bare Carbon Steel | Coating Systems |             |
|--|-------------------|-----------------|-------------|
|  | 1                 | 7               | 28          |
| $I_p$ , mA   | 500               | 150             | 380         |
| $I_q$ , mA   | 440               | 150             | 378         |
| $(I_p)(I_q)(I_p + I_q)$  | 234               | 75              | 189         |
| Average corrosion current density, mA/sq ft (mA/m <sup>2</sup> ) | 2.92 (0.27)       | 0.93 (0.09)     | 2.30 (0.49) |

metal loss or the corrosion rate. Table 10 summarizes the corrosion current densities per square foot, based on Schwerdtfeger's equation (Eq 2), for systems 1, 7, and 28. Determination of  $I_p$  and  $I_q$  was accomplished by extending the tangents of linear portions of the curves and determining their intersection, as shown in Figures 12 through 14.

BEST AVAILABLE COPY

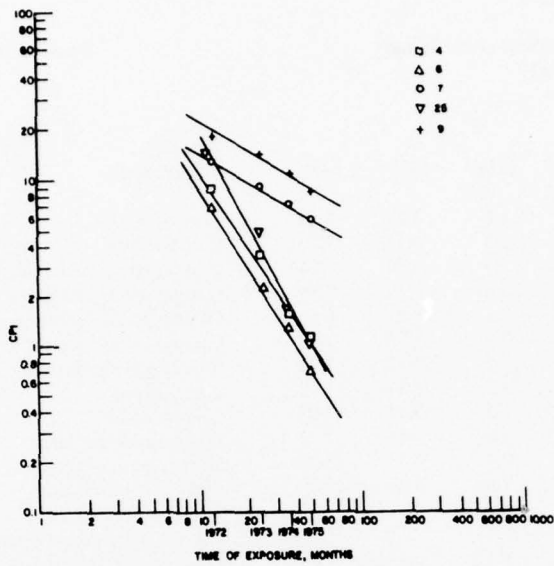

Figure 8. CPI as a function of time of exposure for organic coating systems.

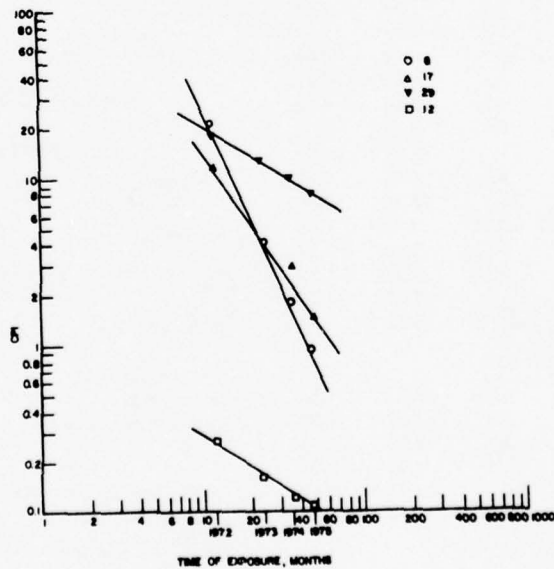

Figure 9. CPI as a function of time of exposure for miscellaneous organic coatings and metal-filled organic coating systems.

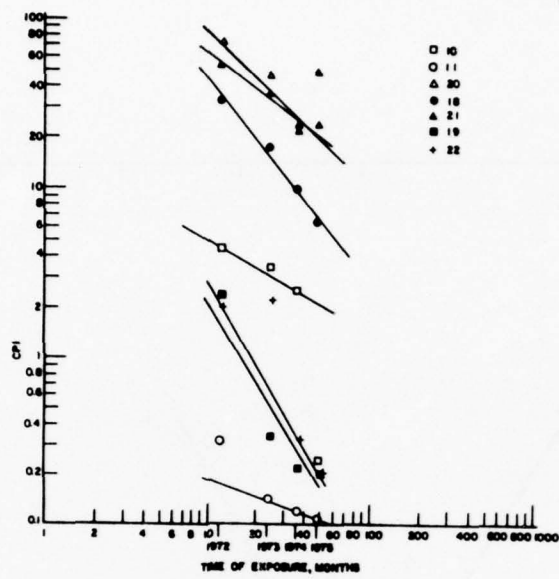

Figure 10. CPI as a function of time of exposure for organic over metal-filled coating systems.

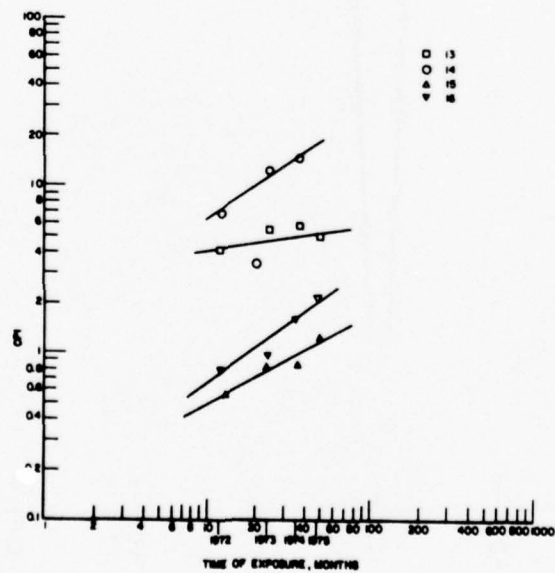

Figure 11. CPI as a function of time of exposure for metallic and organic over metallic systems.

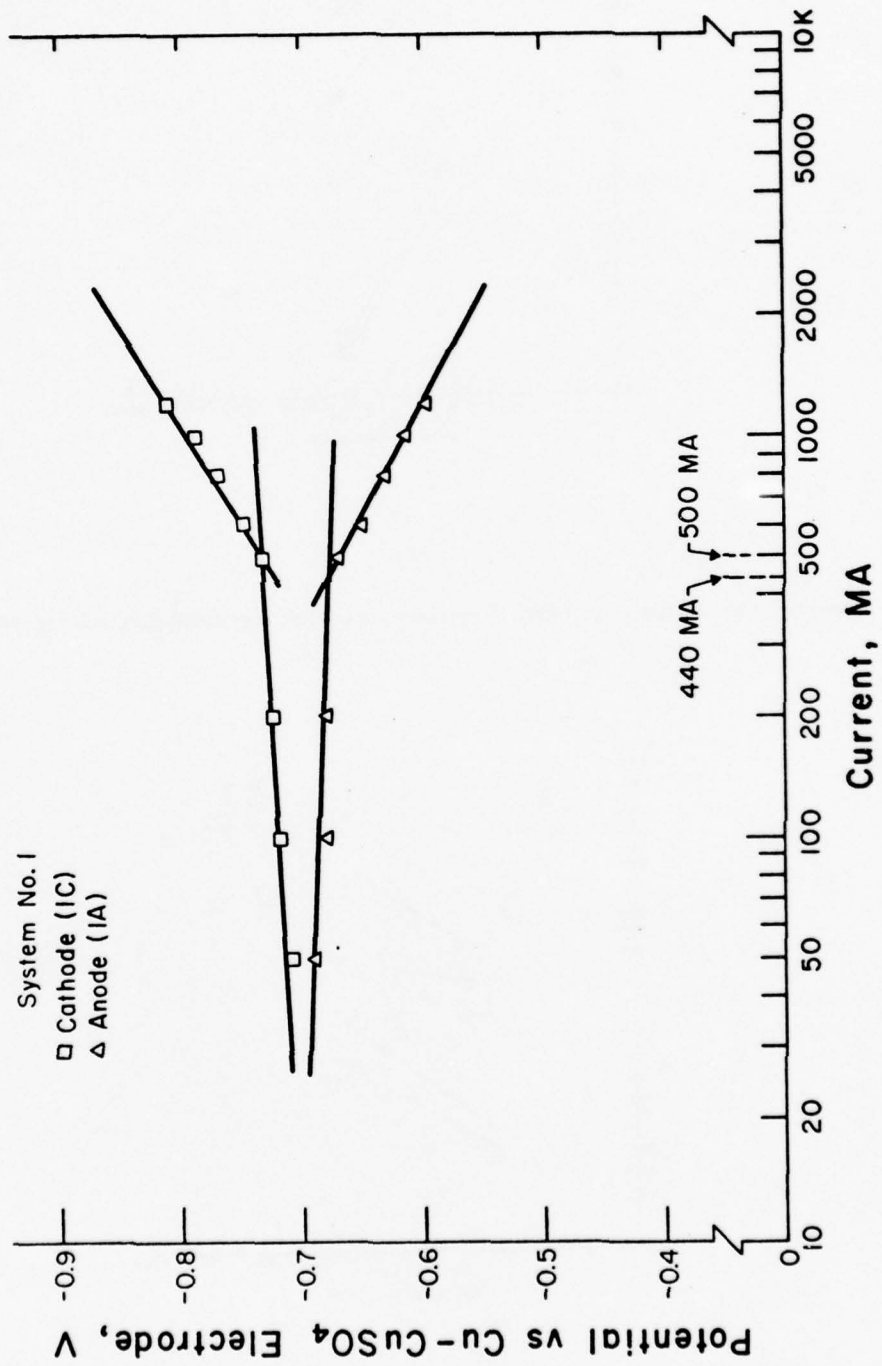

Figure 12. Polarization curves for system 1.

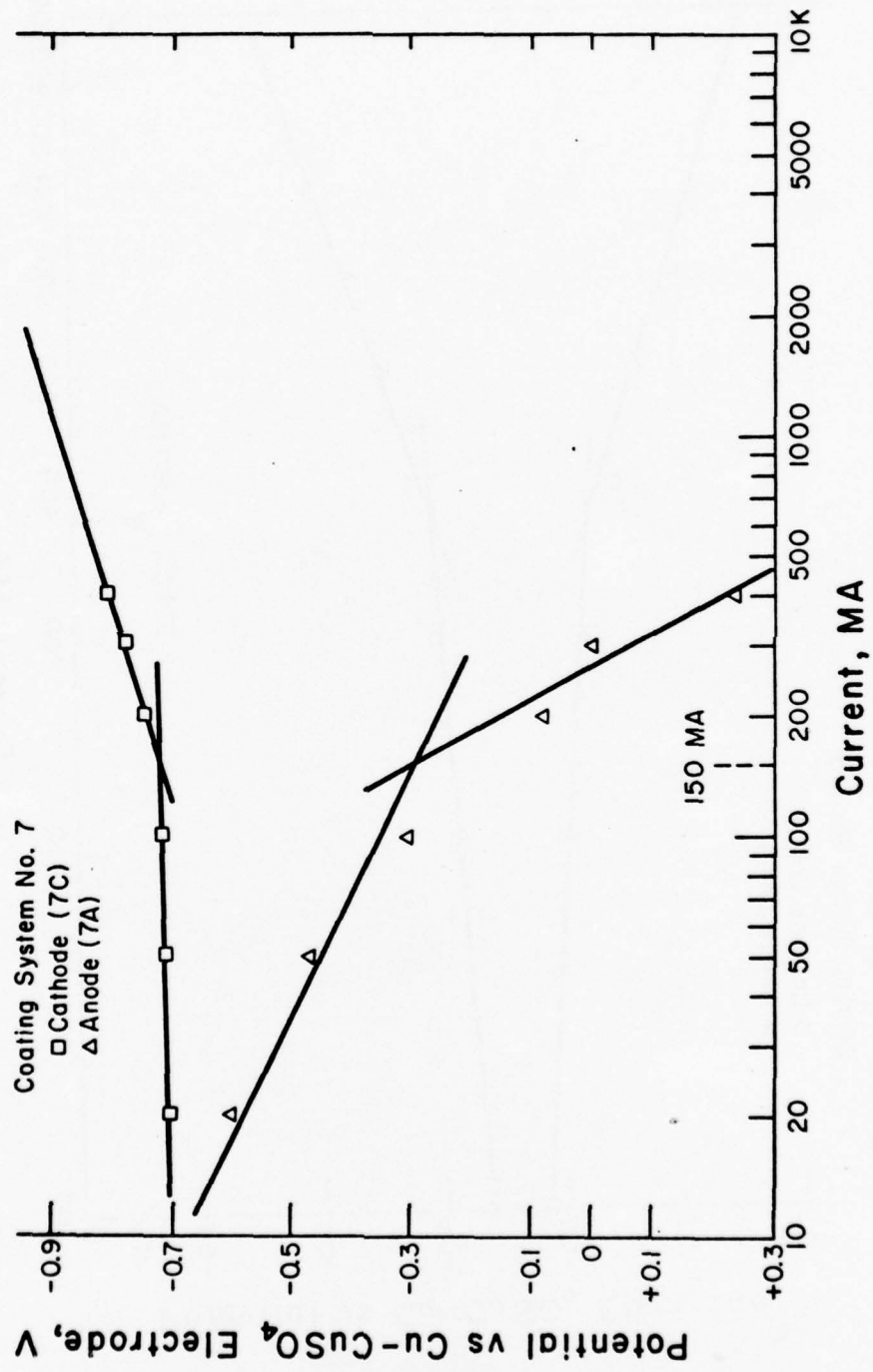

Figure 13. Polarization curves for system 7.

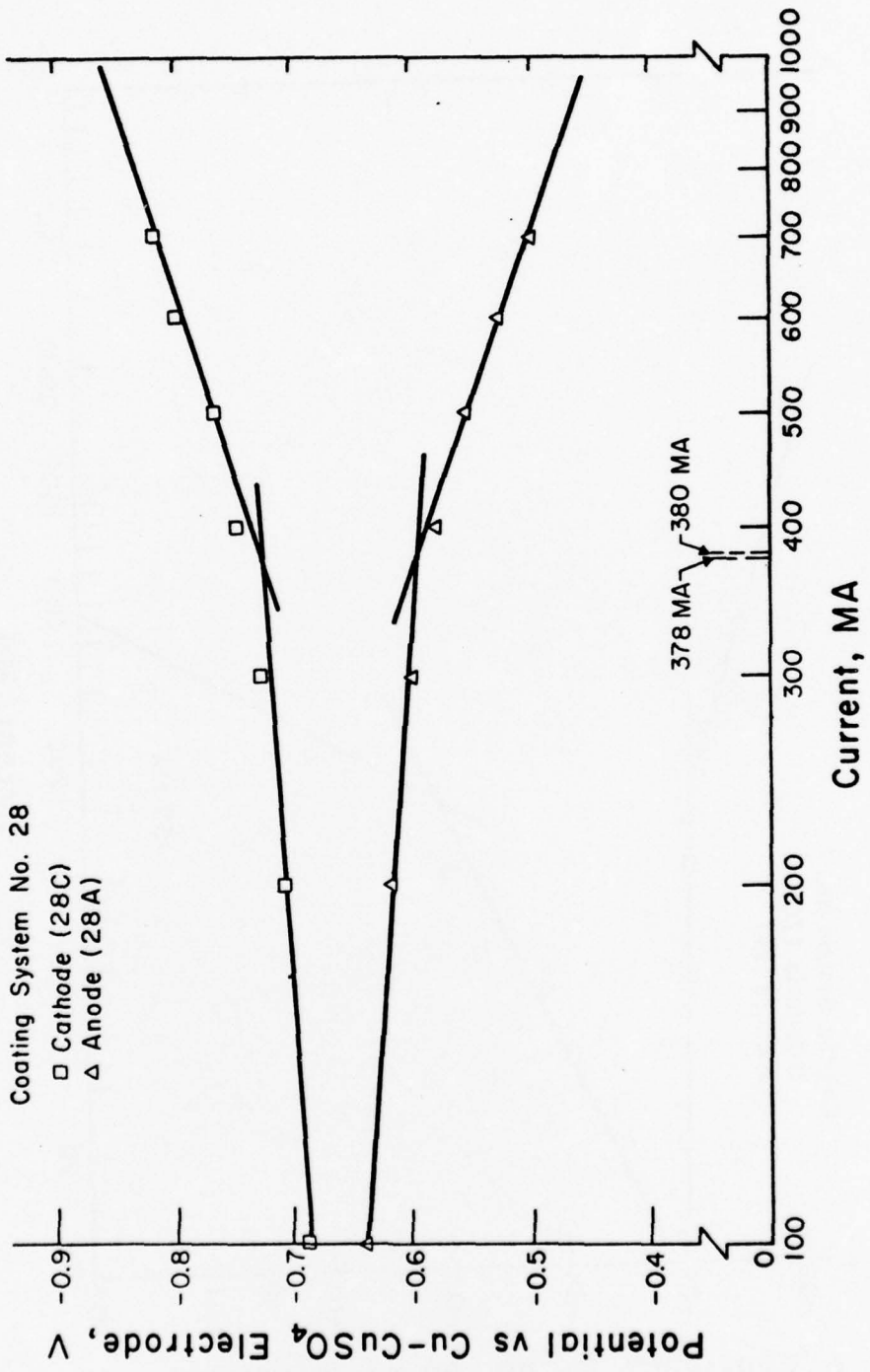

Figure 14. Polarization curves for system 28.

## 4 COST AND EFFECTIVENESS OF PROTECTION

The total cost of preparing and applying a protective coating to a new steel structure depends on many factors (Table 11). This cost, however, is only one of the variables to consider in selecting a coating system (Table 12).

Most of the items shown in Tables 11 and 12 are themselves composed of many factors, depending on the actual application. Consequently, estimating and comparing all these factors for the numerous coatings considered in this study would be a time-consuming task. However, if all factors except the cost of the coating itself, the number of coats, and the effectiveness of protection provided are assumed constant for all the coatings, the cost per square foot of each coating system at the recommended thickness can be estimated and compared with the protection provided (Table 13).

In general, the coatings providing the best protection are more expensive, although some of the more

expensive coatings are also providing only fair to good protection.

Of the systems providing excellent protection, system 9 (coal-tar epoxy over an epoxy primer) was the least costly (24¢/sq ft [ $\$2.58/m^2$ ]), followed closely by a high-build epoxy over an organic zinc-rich primer (system 18) at 28¢/sq ft ( $\$3.01/m^2$ ). Others providing excellent protection were system 10 (high-build epoxy over inorganic zinc-rich primer) at 35¢/sq ft ( $\$3.77/m^2$ ), polyester glassflake (system 29) at 41¢/sq ft ( $\$4.41/m^2$ ), flame-sprayed aluminum (system 13) at 50¢/sq ft ( $\$5.38/m^2$ ), and vinyl-sealed flame-sprayed aluminum (system 14) at 58¢/sq ft ( $\$6.24/m^2$ ).

Good protection was afforded by coating systems ranging between 16¢ and 58¢/sq ft ( $\$1.72$  and  $\$6.24/m^2$ ), while fair coating systems were on the order of 16¢ to 46¢/sq ft ( $\$1.72$  and  $\$4.95/m^2$ ), and poor coating systems ranged from 15¢ to 21¢/sq ft ( $\$1.61$  to  $\$2.26/m^2$ ).

**Table 11**  
Factors Affecting Total Cost of Coating  
New Steel Structures

- I. Surface Preparation
  - A. Blasting, degreasing
  - B. Inspection
  - C. Touch-up blasting
  - D. Inspection
- II. Application of Coating
  - A. Number of coats
    1. Millage per coat
    2. Total millage
  - B. Type of application
    1. Type of equipment
    2. Associated material losses
  - C. Inspection
  - D. Touch-up
    1. Surface preparation
    2. Special touch-up materials
  - E. Inspection
- III. Materials
  - A. Coating
  - B. Thinner
  - C. Solvent (cleanup)
  - D. Rags, etc.
  - E. Touch-up
  - F. Shipping
    1. Non-government-furnished
    2. Government-furnished

**Table 12**  
Variables to Consider in Selecting Coating System

- I. Total cost of preparing and coating (Factors from Table 11)
- II. Durability with respect to application
  - A. Protection
  - B. Appearance
- III. Ease of Application
  - A. Number of coats (Total Millage per Coat)
  - B. Special surface or coating preparation
  - C. Special application environment
    1. Humidity
    2. Temperature
    3. Need for ventilation
  - D. Touch-up
    1. Need for special preparation
    2. Capability to be touched-up
- IV. Curing
  - A. Environment
    1. Humidity
    2. Temperature
  - B. Time
    1. Need to cure between coats
    2. Capability to cure
- V. Safety
  - A. Flammability
  - B. Toxicity
  - C. Ventilation
  - D. Special clothing
  - E. Air-fed respirators
  - F. Solubility in application environment (immersion service)
  - G. Reaction with environment
    1. Chemical
    2. Physical

**Table 13**  
**Relationship Between Cost and Effectiveness of Protection**

| System Class              | System Type                    | System Number | Total No. of Coats | Effectiveness of Protection | Coating Cost/Sq Ft (/m <sup>2</sup> )* |
|---------------------------|--------------------------------|---------------|--------------------|-----------------------------|--|
| Organic coatings          | Coal-tar epoxy                 | 9             | 3                  | E                           | 24¢ (\$2.58)                           |
|                           |                                | 7             | 3                  | G                           | 16¢** (\$1.72)                         |
|                           |                                | 25            | 2                  | G                           | 16¢ (\$1.72)                           |
|                           |                                | 6             | 2                  | P                           | 16¢ (\$1.72)                           |
|                           |                                | 4             | 2                  | F                           | 16¢ (\$1.72)                           |
|                           | Saran                          | 2             | 8                  | P                           | †                                      |
|                           | Phenolic mastic                | 17            | 2                  | G                           | 24¢ (\$2.58)                           |
|                           | Polyester glassflake           | 29            | 2                  | E                           | 41¢ (\$4.41)                           |
| Metal-filled              | Aluminum-pigmented epoxy-tar   | 8             | 3                  | P                           | 21¢ (\$2.26)                           |
| Organic over metal-filled | Zinc-rich primers              | 18            | 3                  | E                           | 28¢ (\$3.01)                           |
|                           |                                | 10            | 3                  | E                           | 35¢ (\$3.77)                           |
|                           |                                | 20            | 3                  | G                           | 25¢ (\$2.69)                           |
|                           |                                | 19            | 2                  | G                           | 25¢ (\$2.69)                           |
|                           |                                | 11            | 3                  | F                           | 31¢ (\$3.34)                           |
|                           |                                | 21            | 2                  | P                           | 15¢ (\$1.61)                           |
|                           |                                | 22            | 3                  | F                           | 46¢ (\$4.95)                           |
| Metallic                  | Flame-sprayed aluminum         | 13            | 2                  | E                           | 50¢ (\$5.38)                           |
| Organic over metallic     | Vinyl <sup>††</sup> (aluminum) | 14            | 4                  | E                           | 58¢ (\$6.24)                           |
|                           | (zinc)                         | 16            | 7                  | G                           | 58¢ (\$6.24)                           |
|                           | Saran (zinc)                   | 15            | 9                  | F                           | 40¢ (\$4.31) <sup>+</sup>              |

\* Based only on cost of coating per applied thickness.

\*\* Does not include aluminum oxide grit.

† Saran coating is no longer made.

†† The vinyl in this case refers to a sealer which is mostly absorbed by the porous metallic coating.

+ Cost does not include saran, which is no longer made.

Since the coating cost has been estimated to be 15 to 25 percent of the total cost of applying a coating to a new structure, the cost of the coating is secondary to the effectiveness of protection. After 5 years, six of the individual coating systems have provided excellent protection at a reasonable cost. The flame-sprayed aluminum is more expensive than the organic coatings,

but has been found by other investigators<sup>5</sup> to be providing excellent protection after more than 18 years of immersion service.

<sup>5</sup>C. F. Schrieber, F. N. Longo, and G. J. Duiman, *Proceedings of the Offshore Technological Conference, Report No. 159* (1974).

## 5 COMPARISON OF LACOSTA ISLAND AND DAM NECK SITES

### Environmental Effects

Table 14 compares the data gathered after the removal of pilings from the LaCosta Island and Dam Neck sites. In addition to the rank, average visual rating (ASTM D 610-68), and corrosion rate listed for Dam Neck,<sup>6</sup> this table also provides the normalized structure factor and coating costs for LaCosta Island. The information from this table, along with the physical characteristics of the two sites (Table 15), indicates the difference in corrosion behavior that can be associated with the contrast in environment.

Since the mechanism of corrosion depends on the corrosion environment, temperature, salinity, water (wave) velocity, and bottom composition can affect the extent and form of corrosion. It is well known that corrosion reactions (kinetics) increase with temperature and that the velocity and composition of the corroding slurry affect the extent of erosion-corrosion. Marine (biological) fouling, which depends on water velocity, temperature, biological slime film, type and texture of surface, gravity, light, exfoliating nature, and surface free energy,<sup>7</sup> can also affect coating performance.

Table 15 indicates the physical differences in the LaCosta Island and Dam Neck sites. At LaCosta Island, the mean yearly temperature is 23°F (10°C) higher, the salinity 6.2 ppt higher, and the wave action less severe than at Dam Neck. At Dam Neck the wave action is quite severe, since the pilings are exposed directly to the Atlantic Ocean and the wave action associated with coastal weather. The strong surf action and crosscurrents associated with the Dam Neck site cause suspension of large volumes of sand and debris, which impinge on the piles, thus increasing susceptibility to erosion-corrosion damage. Local eddy currents caused by the pilings also increase the water velocity in the vicinity of the pilings. The bottom elevation of the Dam Neck site is continually changing due to local sand action and movement of sand associated with winter storms, hurricanes, and long summer swells.<sup>8</sup> In

<sup>6</sup>J. R. Lesnick, *Condition of Test Piles After 5 Years of Exposure at Dam Neck, VA*, Interim Report (Coastal Engineering Research Center, 1976).

<sup>7</sup>J. R. Saroyan, et al., *Industrial Engineering Chemical, Proceedings of the Research Division*, 9-2 (1970), p 123.

<sup>8</sup>E. Escalante, et al., *Protection of Steel Piles in a Natural Seawater Environment—Part II*, NBSIR 76-1104 (National Bureau of Standards, 1976).

contrast, the LaCosta Island site is well protected from violent wave action. The bottom material at LaCosta Island consists of coarse sand and shell, while that of Dam Neck is primarily fine sand over a thin layer of clay. These contrasts in physical characteristics suggest that the LaCosta Island site would be more conducive to damage by marine organisms and higher average corrosion rates (associated with increase in temperature and salinity), while Dam Neck would be affected more by erosion-corrosion and damage to the atmospheric-splash zone. Successful coatings at LaCosta Island would be those more resistant to attack by marine organisms, while the durability and abrasion resistance of the coatings at Dam Neck would be more important factors.

Table 14 indicates the importance of the location and physical environment on the protective behavior of any system. Coal-tar epoxy over zinc-rich primer, vinyl-sealed, flame-sprayed aluminum, and polyester glassflake performed extremely well at both locations; similarly, the coal-tar epoxies and saran did fairly and poorly, respectively, at both sites.

### Comparison of Corrosion Rate Profiles and CPI

Figures 15 through 19 give the corrosion rate profiles for pilings of bare carbon steel, bare mariner steel, cathodically protected bare carbon steel, coal-tar epoxy with cathodic protection, and coal-tar epoxy over an organic zinc-rich primer exposed at LaCosta Island. The corrosion profiles are very similar for all systems in the embedded zone, since all pilings were bare in this zone. The average corrosion rate for the embedded zone was found to be 1.1 mil/year (0.03 mm/year), which is comparable to the value of 1.4 mil/year (0.04 mm/year) found by Hunter and Horton<sup>9</sup> to be the corrosion rate of steel embedded in sand.

A slight increase in the corrosion rate in the sand-swept zone was noticed for the bare pilings with and without cathodic protection. This indicates that damage due to erosion-corrosion is minimal. On coated piles, the rate of corrosion in the sand-swept zone was found to be very low, with the suspended sand and shell acting to clean the surface without appearing to physically damage the coating.

The corrosion profile of the bare mariner steel is very similar to that of the bare carbon steel in both the

<sup>9</sup>A. D. Hunter and C. H. Horton, *Underwater Engineering* (November 15, 1960).

Table 14  
Summary of Results for LaCosta Island and Dam Neck Sites

|            |  | LaCosta Island          |                                      |                                    |        |               |                             |  |      |                       |                              | Dam Neck ***                         |  |  |  |
|------------|--|-------------------------|--------------------------------------|------------------------------------|--------|---------------|-----------------------------|--|------|-----------------------|------------------------------|--------------------------------------|--|--|--|
| System No. | Description                              | Corrosion Rate, mil/yr* |                                      |                                    |        |               | Normalized Structure Factor | Coating Cost,**<br>¢/Sq. ft (\$/m <sup>2</sup> ) | Rank | Average Visual Rating |                              | Corrosion Rate, mil/yr               |  |  |  |
|            |  | Average                 | Atmospheric Zone (1-6 ft [0.3-1.8m]) | Immersed Zone (7-17 ft [2.1-5.2m]) | Rank   | Visual Rating |                             |  |      | Average               | Atmospheric Zone (0.3-4.6 m) | Immersed Zone (14-20 ft [4.3-6.1 m]) |  |  |  |
| 29         | Polyester glassflake                     | <0.0                    | <0.0                                 | <0.1                               | 100.00 | 41 (4.41)     | 5                           | 9.3  | (0.1 | (0.1                  | (0.1                         | (0.1                                 |  |  |  |
| 18         | Coal-tar epoxy (C-200)/organic zinc-rich | 8.33                    | 0.3                                  | 0.3                                | 99.25  | 28 (3.01)     | 11                          | 9.1  | 0.19 | 0.24                  | 0.15                         | 0.15                                 |  |  |  |
| 10         | Epoxy/inorganic ceramic                  | 9.67                    | 0.81                                 | 0.7                                | 98.96  | 35 (3.77)     |                             |  |      |                       |                              |                                      |  |  |  |
| 14         | Vinyl/aluminum flame-spray               | 6.00                    | <0.1                                 | <0.1                               | 98.57  | 50 (5.38)     | 2                           | 7.3  | 0.16 | 0.03                  | 0.32                         | 0.32                                 |  |  |  |
| 5          | Coal-tar epoxy (C-200)/zinc anodes       | 9.67                    | 0.82                                 | 0.1                                | 98.48  | 24+A (2.58)   |                             |  |      |                       |                              |                                      |  |  |  |
| 9          | Aluminum flame-sprayed                   | 9.33                    | 1.58                                 | 1.4                                | 98.35  | 24 (2.58)     |                             |  |      |                       |                              |                                      |  |  |  |
| 13         | Coal-tar epoxy with alumina armor        | 6.67                    | 1.41                                 | 1.6                                | 98.23  | 50 (5.38)     | 9                           | 7.4  | 0.03 | 0                     | 0.17                         | 0.17                                 |  |  |  |
| 16         | Vinyl/zinc flame-spray                   | 8.00                    | 0.7                                  | 0.7                                | 97.82  | 16+ (1.72)    | 16                          | 8.3  | 0.55 | 2.7                   | 0.07                         | 0.07                                 |  |  |  |
| 25         | Coal-tar epoxy (C-200) on mariner steel  | 7.00                    | 1.16                                 | 1.0                                | 97.72  | 58 (6.24)     | 18                          | 4.9  | 1.4  | 2.3                   | 3.2                          | 3.2                                  |  |  |  |
| 17         | Phenolic mastic                          | 7.00                    | 0.47                                 | 0.3                                | 97.68  | 16+M (1.72)   | 15                          | 7.7  | 0.53 | 1.6                   | 0.44                         | 0.44                                 |  |  |  |
| 20         | Epoxy polyamide/inorganic zinc-rich      | 8.33                    | 1.14                                 | 1.4                                | 97.61  | 24 (2.58)     | 8                           | 9.0  | 0.14 | 0.21                  | 0.11                         | 0.11                                 |  |  |  |
| 15         | Saran/zinc flame-spray                   | 7.00                    | <0.1                                 | <0.1                               | 97.50  | 25 (2.69)     | 3                           | 8.3  | 0.05 | 0                     | 0.22                         | 0.22                                 |  |  |  |
| 24         | Bare mariner steel/zinc anodes           | 3.00                    | 1.48                                 | 0.3                                | 97.28  | 40+PVC (4.31) | 6                           | 8.4  | 0.10 | 0.29                  | 0.14                         | 0.14                                 |  |  |  |
| 4          | Coal-tar epoxy (C-200)                   |                         | 3.38                                 | 7.8                                | 96.26  | M+A           |                             |  |      |                       |                              |                                      |  |  |  |
| 15         | Vinyl mastic/inorganic zinc-rich         | 6.33                    | 0.70                                 | 0.9                                | 95.99  | 16 (1.72)     | 14                          | 8.2  | 0.53 | 2.1                   | 0.21                         | 0.21                                 |  |  |  |
| 16         | Vinyl mastic/inorganic zinc-rich         | 4.00                    | 1.42                                 | 0.9                                | 95.42  | 46 (4.95)     | 13                          | 7.6  | 0.24 | 0                     | 1.40                         | 1.40                                 |  |  |  |
| 19         | Vinyl/inorganic zinc-rich                | 6.00                    | 4.99                                 | 0.9                                | 94.58  | 25 (2.69)     | 12                          | 8.6  | 0.20 | 0.31                  | 0.22                         | 0.22                                 |  |  |  |
| 6          | Coal-tar epoxy (Tarset)                  | 6.67                    | 1.44                                 | 1.5                                | 93.40  | 16 (1.72)     | 17                          | 7.7  | 0.80 | 2.9                   | 0.72                         | 0.72                                 |  |  |  |
| 21         | Epoxy-tar/inorganic zinc-rich            | 4.67                    | 1.23                                 | 0.7                                | 92.56  | 15 (1.61)     |                             |  |      |                       |                              |                                      |  |  |  |
| 8          | Epoxy-tar (aluminum pigment)             | 7.33                    | 0.63                                 | 0.3                                | 91.94  | 21 (2.26)     | 4                           | 8.9  | 0.07 | 0.03                  | 0.06                         | 0.06                                 |  |  |  |
| 11         | Epoxy/inorganic zinc-rich                | 5.33                    | 6.38                                 | 1.5                                | 91.84  | 31 (3.34)     |                             |  |      |                       |                              |                                      |  |  |  |
| 12         | Saran                                    | 6.67                    | 3.69                                 | 2.0                                | 89.93  | PVC           | 19                          | 6.4  | 2.4  | 3.5                   | 4.9                          | 4.9                                  |  |  |  |
| 2          | Bare carbon/zinc anodes                  |                         | 8.34                                 | 16.4                               | 86.92  | A             |                             |  |      |                       |                              |                                      |  |  |  |
| 3          | Bare carbon/aluminum anodes              |                         | 10.32                                | 28.0                               | 82.13  | A             |                             |  |      |                       |                              |                                      |  |  |  |
| 23         | Bare mariner steel                       |                         | 18.37                                | 23.5                               | 81.91  | M             |                             |  |      |                       |                              |                                      |  |  |  |
| 1          | Bare carbon steel                        |                         | 28.23                                | 32.0                               | 77.05  |               | 20                          |  | 6.0  | 12.2                  | 9.7                          | 9.7                                  |  |  |  |

\*S1 conversion factor: 1 mil = 0.0254 mm.

\*\*Under cost, A refers to additional costs from anodes (20¢ extra per sq. ft. [\$2.15/m<sup>2</sup>]), M is for mariner steel (10¢ extra per sq. ft. [\$1.08/m<sup>2</sup>]), + is for the aluminum oxide armor, and PVC is no longer available and cannot be figured into the cost.

\*\*\*The average visual rating for the Dam Neck site was obtained from J. R. Lesnick, *Condition of Test Piles After 5 years of Exposure at Dam Neck, VA*, Interim Report (Coastal Engineering Research Center, 1976), and the rank and corrosion rates were taken from A. D. Hunter and C. H. Horton, *Underwater Engineering* (November 15, 1960).

BEST AVAILABLE COPY

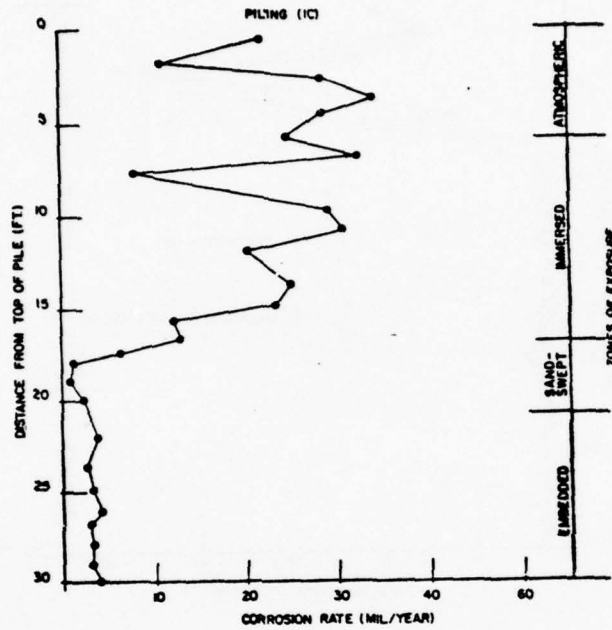

Figure 15. Corrosion profile of bare carbon steel. SI conversion factors: 1 ft = 0.3048 m; 1 mil = 0.0254 mm.

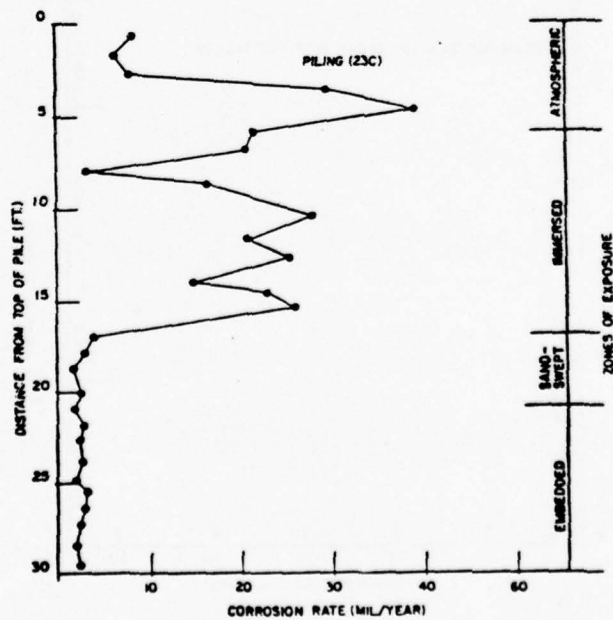

Figure 16. Corrosion profile of bare mariner steel. SI conversion factors: 1 ft = 0.3048 m; 1 mil = 0.0254 mm.

BEST AVAILABLE COPY

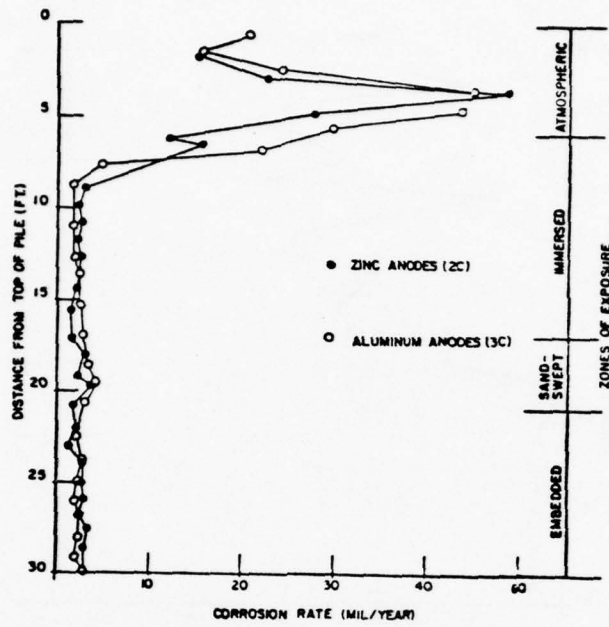

Figure 17. Corrosion profile of cathodically protected bare carbon steel. SI conversion factors: 1 ft = 0.3048 m; 1 mil = 0.0254 mm.

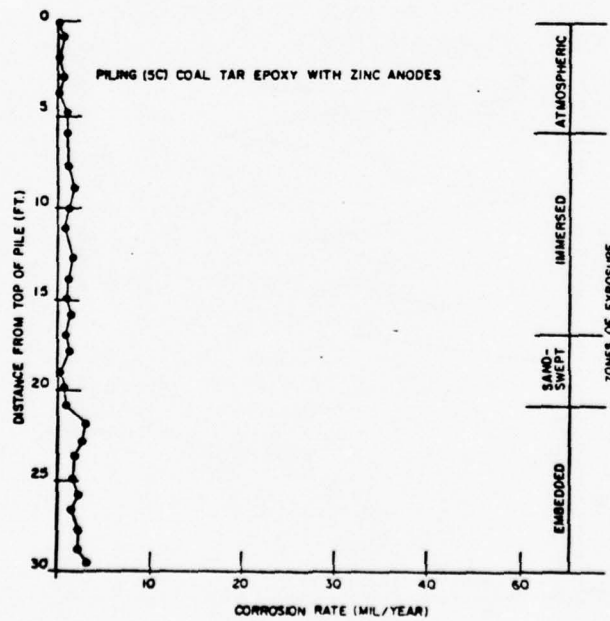

Figure 18. Corrosion profile of coated, cathodically protected piling. SI conversion factors: 1 ft = 0.3048 m; 1 mil = 0.0254 mm.

BEST AVAILABLE COPY

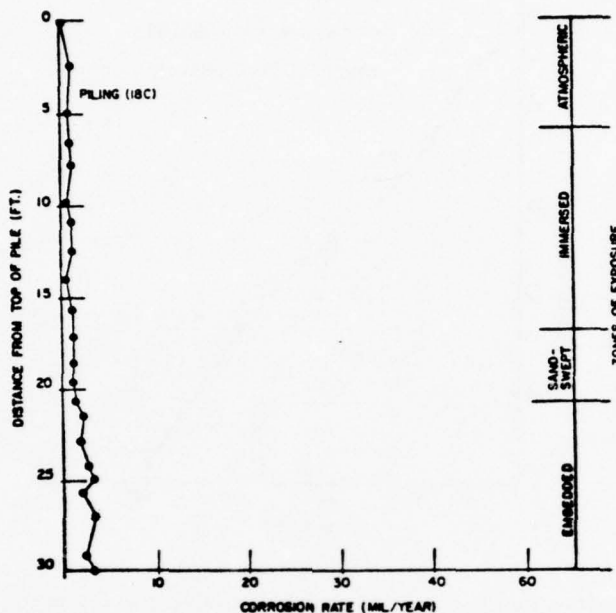

Figure 19. Corrosion profile of coal-tar epoxy over organic zinc-rich primer. SI conversion factors: 1 ft = 0.3048 m; 1 mil = 0.0254 mm.

Table 15

Physical Characteristics of LaCosta Island and Dam Neck Sites\*

|                   | LaCosta        | Dam Neck       |
|-------------------|----------------|----------------|
| Mean yearly temp. | 75°F (24°C)    | 58°F (14°C)    |
| Mean salinity     | 33 ppt         | 26.8 ppt       |
| Mean tide level   | 1.3 ft (0.4 m) | 1.7 ft (0.5 m) |
| Spring tide range | 2.6 ft (0.8 m) | 4.1 ft (1.2 m) |
| Wave action       | Light breakers | Heavy breakers |

\*Coast and Geodetic Survey Pub. 31-1, 4th ed. (U. S. Department of Commerce, 1972).

immersed and atmospheric zones; the difference in corrosion rate is not great enough to justify use of the mariner steel alone as a means of corrosion prevention.

The use of zinc and aluminum anodes reduces corrosion in the immersed zone, but has little effect on corrosion in the atmospheric zone, because the

sacrificial protection mechanism is only operative in the immersed zone.

The addition of a coating to a cathodically protected system reduces the corrosion in the atmospheric zone. The corrosion profile of a coated, cathodically protected pile is nearly identical to the profile of a coated pile providing equivalent protection. The advantage of the coated, cathodically protected system is its capability to protect the steel when damage to the coating in the immersion zone occurs. This should extend the long-term life of the system.

The rate of consumption of the zinc and aluminum anodes applied to the bare pilings at LaCosta Island was found to be 1.6 and 0.8 lb/year (0.7 and 0.4 kg/year), respectively. Figures 20 and 21 show the pit distribution for the respective anodes; the average pit depth was on the order of 0.25 in. (6.4 mm) for both anodes.

The corrosion profiles constructed by Escalante, et al.<sup>10</sup> for the Dam Neck piles indicate similar behavior

<sup>10</sup>E. Escalante, et al., *Protection of Steel Piles in a Natural Seawater Environment—Part II*, NBSIR 76-1104 (National Bureau of Standards, 1976).

BEST AVAILABLE COPY

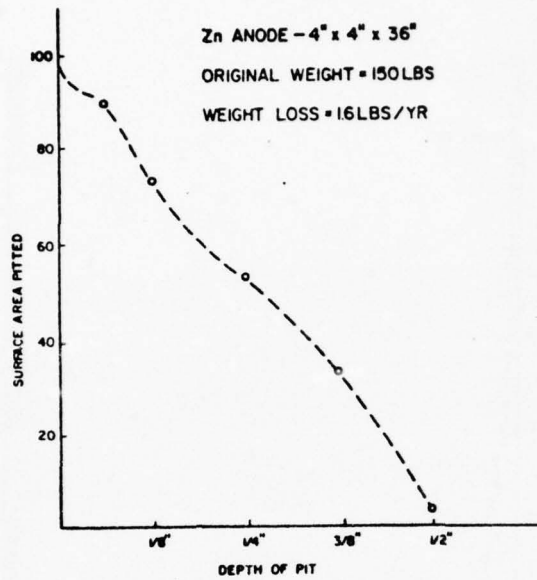

Figure 20. Pit distribution for zinc anodes. SI conversion factors: 1 in. = 2.54 cm; 1 lb = 0.4536 kg.

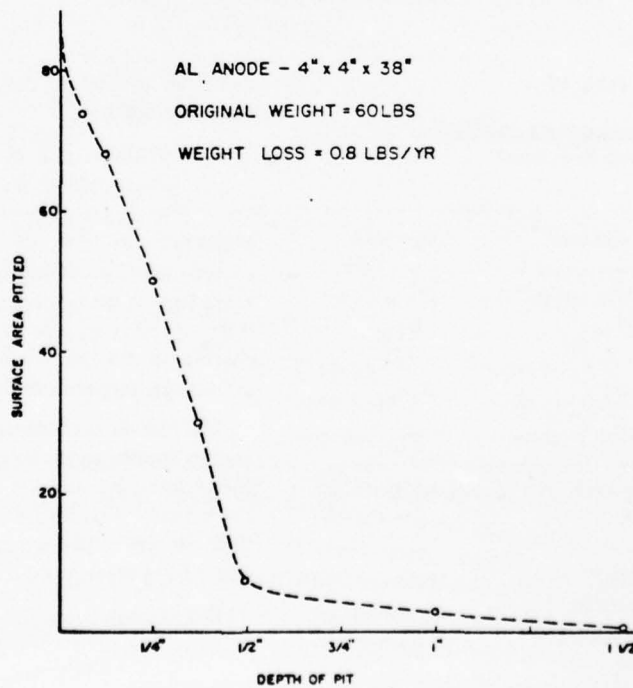

Figure 21. Pit distribution for aluminum anodes. SI conversion factors: 1 in. = 2.54 cm; 1 lb = 0.4536 kg.

to those of LaCosta Island. No comparison of cathodically protected systems can be made because no data for cathodically protected pilings from the Dam Neck system are available.

Figures 22 and 23 show the cathodic protection index<sup>11</sup> as a function of corrosion rate for the LaCosta Island and Dam Neck pilings, respectively. The data from both sites reveal sharp declines in CPI with increasing corrosion rate for each independent generic system. At low corrosion rates, the CPI appears to depend on the specific generic system, while high corrosion rates are associated with low CPI, regardless of the generic system. The bare steel baseline was included to indicate the low CPI coupled with the high corrosion rates generated by the bare steel, in comparison to any of the coating systems. The correlation between CPI and corrosion rate was determined by computer analysis to be 80 percent for all systems.

Data presently available from the Dam Neck site were used to analyze the behavior of corrosion current with respect to the corrosion rate, as shown in Figure

<sup>11</sup>M. Romanoff, et al., "Protection of Steel Piles in a Natural Seawater Environment," *Proceedings, Third International Congress on Marine Corrosion and Fouling* (1973).

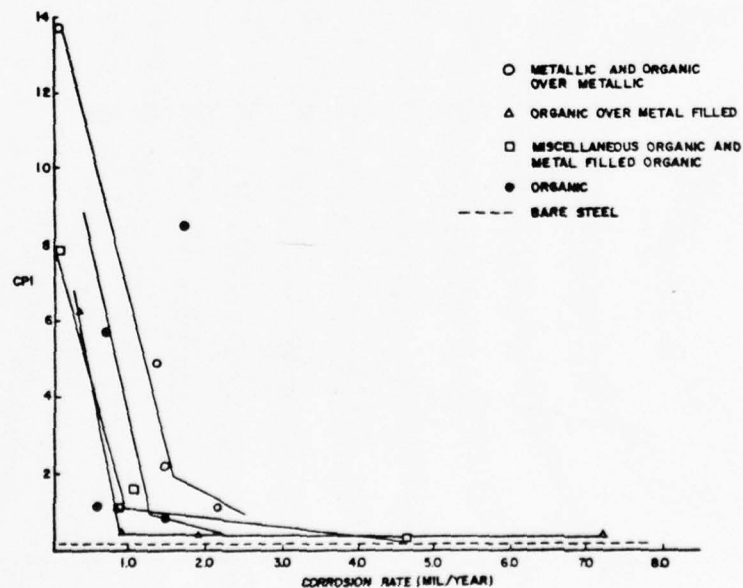

Figure 22. Cathodic protection index as a function of corrosion rate for LaCosta Island pilings. SI conversion factor: 1 mil = 0.0254 mm.

24. A computer analysis was conducted to determine the degree of correlation between corrosion current and corrosion rate. A strong correlation of 0.9 was found to exist. Since the corrosion current is determined by polarization measurements, this method provides a nondestructive testing technique of monitoring corrosion of steel immersed in water.

## 6 CONCLUSIONS AND RECOMMENDATIONS

### Conclusions

The following conclusions are based on the 5-year results:

1. Coal-tar epoxy over organic zinc-rich primer, polyester glassflake, and vinyl-sealed, flame-sprayed aluminum coatings performed excellently at both LaCosta Island, FL and Dam Neck, VA test sites.

2. Sacrificial anodes of zinc and aluminum effectively reduced the corrosion in the immersed zone from 26.2 mil/year (0.67 mm/year) to 4.0 and 0.8 mil/year (0.10 and 0.02 mm/year), respectively.

BEST AVAILABLE COPY

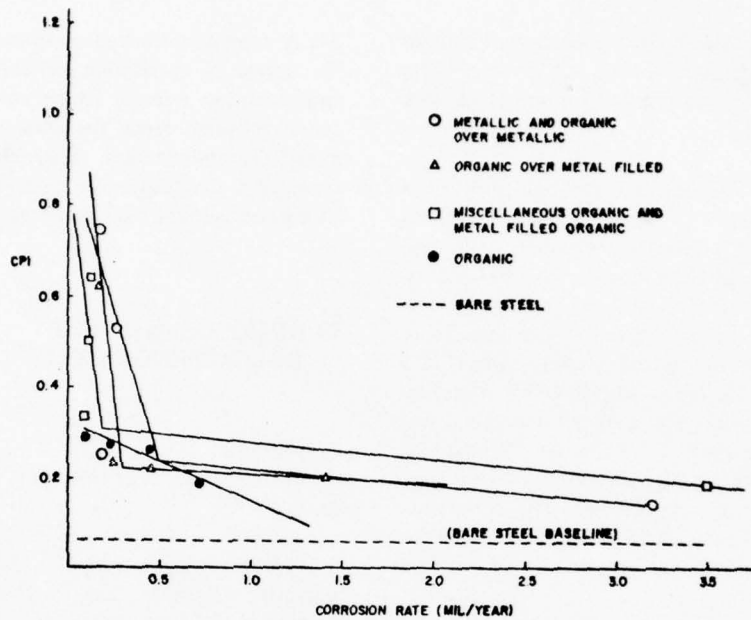

Figure 23. Cathodic protection index as a function of corrosion rate for Dam Neck pilings. CPI data were obtained from M. Romanoff, et al., "Protection of Steel Piles in a Natural Seawater Environment," *Proceedings, Third International Congress on Marine Corrosion and Fouling* (1973), and corrosion rates from E. Escalante, et al., *Protection of Steel Piles in a Natural Seawater Environment—Part II*, NBSIR 76-1104 (National Bureau of Standards, 1976). SI conversion factor: 1 mil = 0.0254 mm.

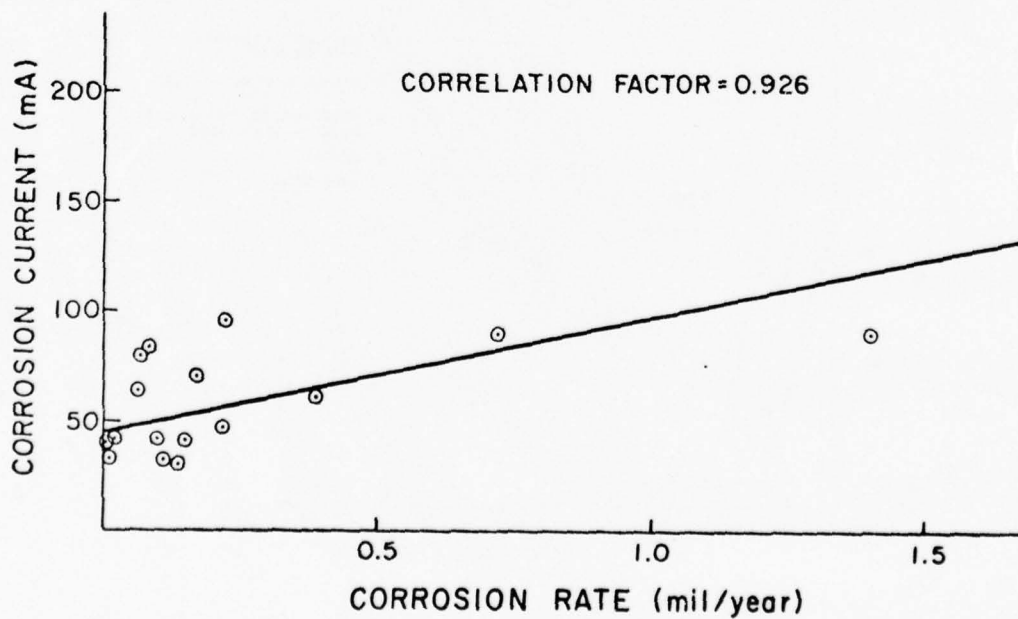

Figure 24. Corrosion rate vs. corrosion current. SI conversion factor: 1 mil = 0.0254 mm.

3. Coal-tar epoxy coating with zinc anodes for cathodic protection provides protection to the atmospheric zone and immersed zone and has the added capability of protecting the steel in the immersed zone should damage to the coating occur.

4. Electrochemical measurements of cathodic protection index and polarization current provide a powerful nondestructive testing technique for monitoring corrosion of steel immersed in water.

#### Recommendations

It is recommended that:

1. Zinc-rich primers be used as a means of reducing corrosion.

2. Sacrificial anodes be used as a means of providing cathodic protection to the immersed zone of coated or bare steel.

3. Use of the cathodic protection index and polarization measurement be continued for development as nondestructive testing techniques for monitoring corrosion of steel immersed in water.

#### REFERENCES

- Coast and Geodetic Survey, Pub. 31-1*, 4th Ed. (U. S. Department of Commerce, 1972).
- Escalante, E., et al., *Protection of Steel Piles in a Natural Seawater Environment—Part II*, NBSIR 76-1104 (National Bureau of Standards, 1976).
- Evaluating Degree of Rusting on Painted Steel Structures*, ASTM D 610-68 (American Society for Testing and Materials, 1968).
- Holler, H. D., *Journal of the Electrochemical Society*, Vol 97 (1950), p 277.
- Hunter, A. D. and C. H. Horton, *Underwater Engineering* (November 15, 1960).
- Kumar, A. and C. Hahin, *First Annual Inspection of Buzzards Bay Pilings*, Technical Report M-172/ADA024381 (U. S. Army Construction Engineering Research Laboratory [CERL], 1976).
- Lesnick, J. R., *Condition of Test Piles after 5 Years of Exposure at Dam Neck, VA*, Interim Report (Coastal Engineering Research Center, 1976).
- Pearson, J. M., *Transactions of the Electrochemical Society*, Vol 81 (1942), p 485.
- Romanoff, M., et al., "Protection of Steel Piles in a Natural Seawater Environment," *Proceedings, Third International Congress on Marine Corrosion and Fouling* (1973).
- Saroyan J. R., E. Lindner, C. Dooley, and H. R. Bleile, *Industrial Engineering Chemical, Proceedings of the Research Division*, 9-2 (1970), pp 122-133.
- Schrieber, C. F., F. N. Longo, and G. J. Duiman, *Proceedings of the Offshore Technological Conference, Report No. 1959* (1974).
- Schwerdtfeger, W. J. and O. N. McDorman, *Journal of the Electrochemical Society*, Vol 99 (1952), p 407.

APPENDIX A:

PHOTOGRAPHS OF CORROSION  
DAMAGE TO STEEL PILING AT  
LACOSTA ISLAND, FL

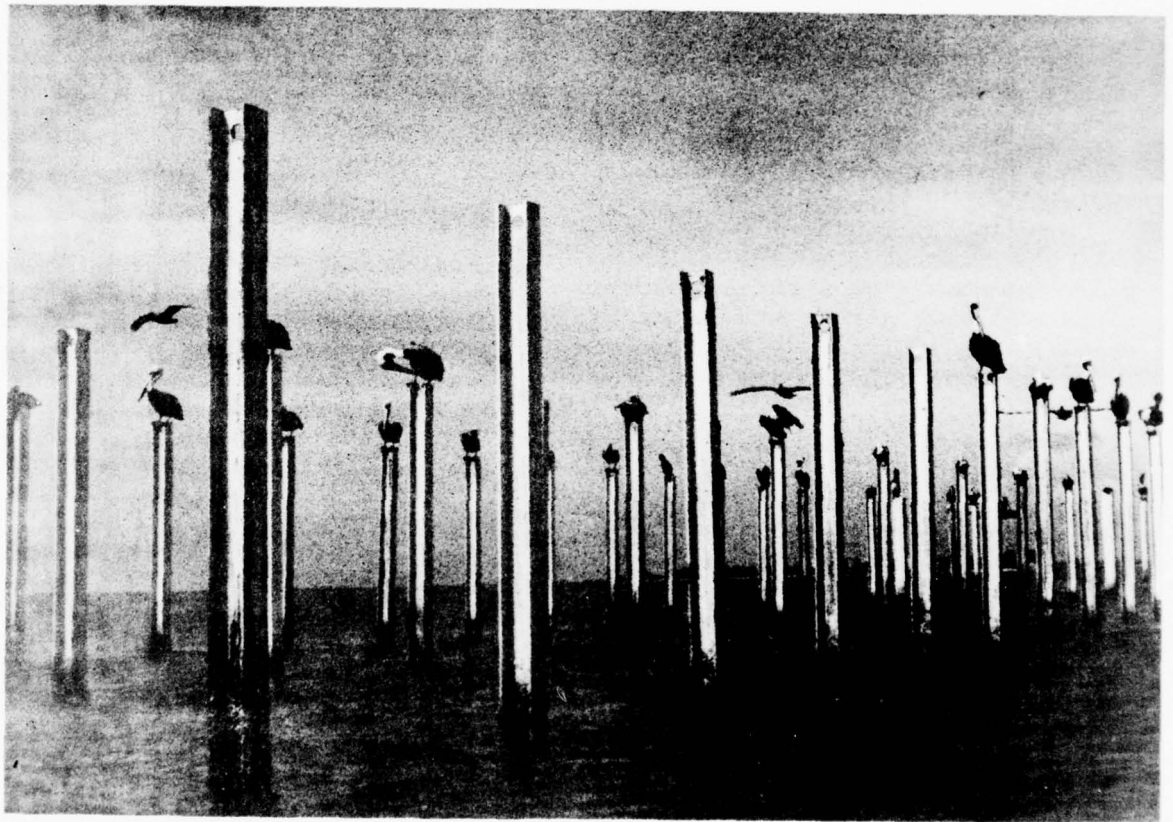

*Figure A1. LaCosta Island piling test site.*

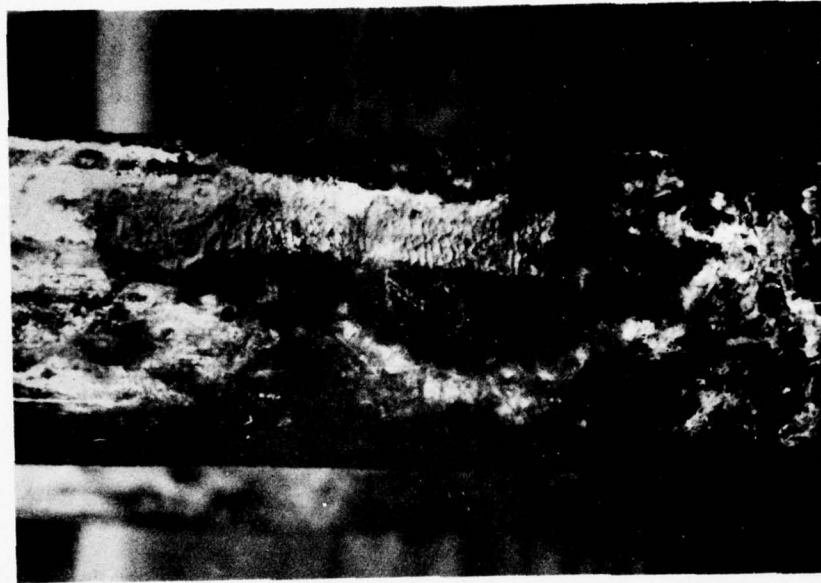

**Figure A3.** Atmospheric zone of bare carbon steel with aluminum anodes. Cathodic protection is only operative in the immersed zone, as seen from the damage present in the atmospheric zone of this pile.

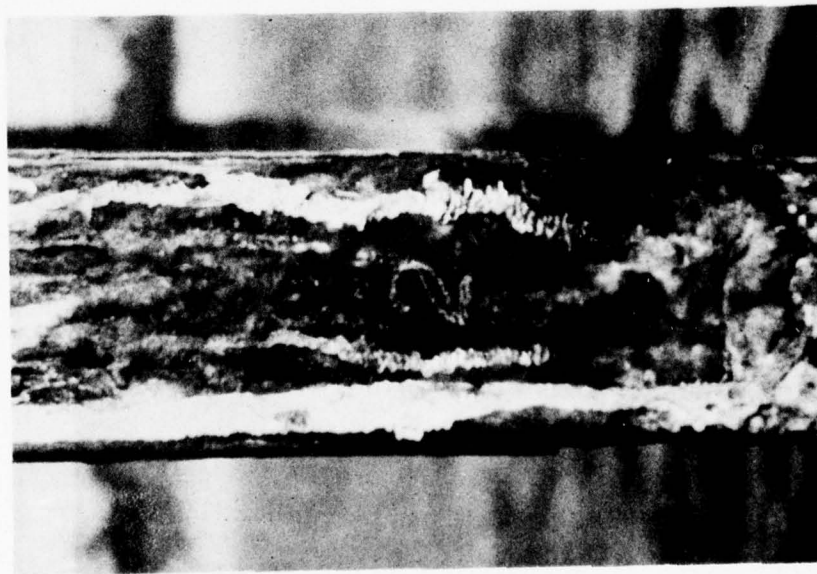

**Figure A2.** Atmospheric zone of bare carbon steel with zinc anodes. Absence of protection against corrosion in the atmospheric zone is evident.

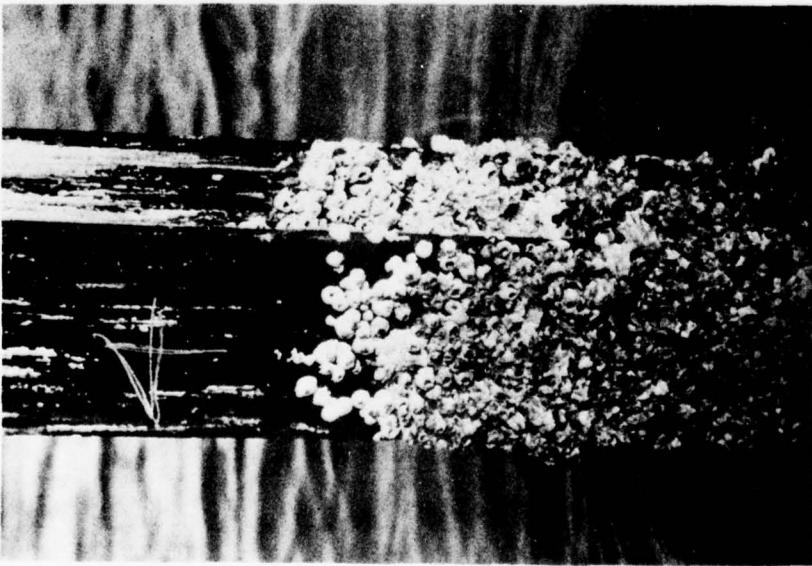

**Figure A4.** Coal-tar epoxy (C-200) on carbon steel. Photograph of upper immersed and lower atmospheric zones indicates the degree of marine fouling. Some damage to the flanges is also evident.

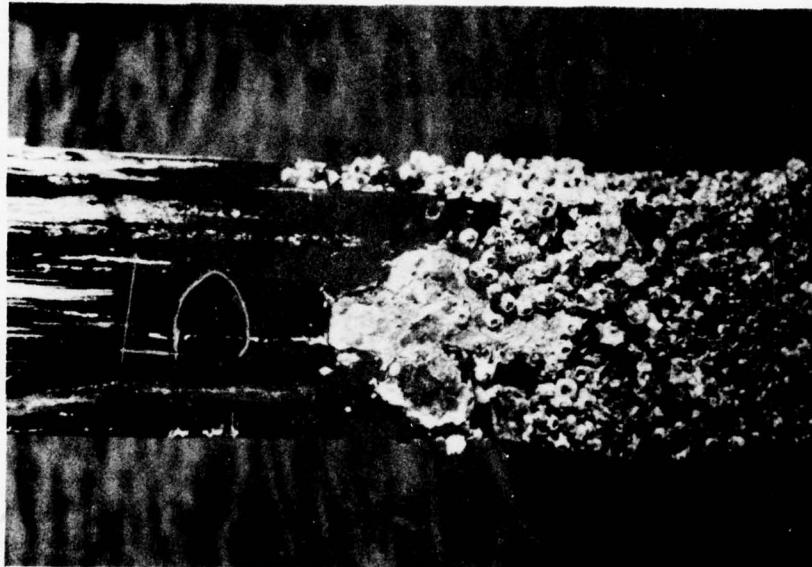

**Figure A5.** Coal-tar epoxy (C-200) with zinc anodes. Marine fouling is evident in the upper immersed zone, and some damage is present on the face of the pile in the atmospheric zone.

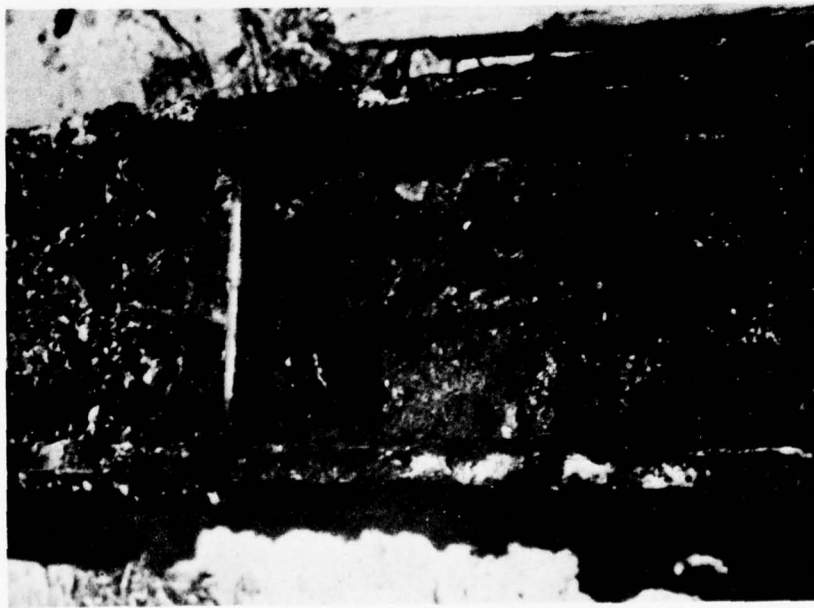

**Figure A6.** Bare carbon steel with zinc anodes after 5-year removal. Damage to atmospheric zone is evident.

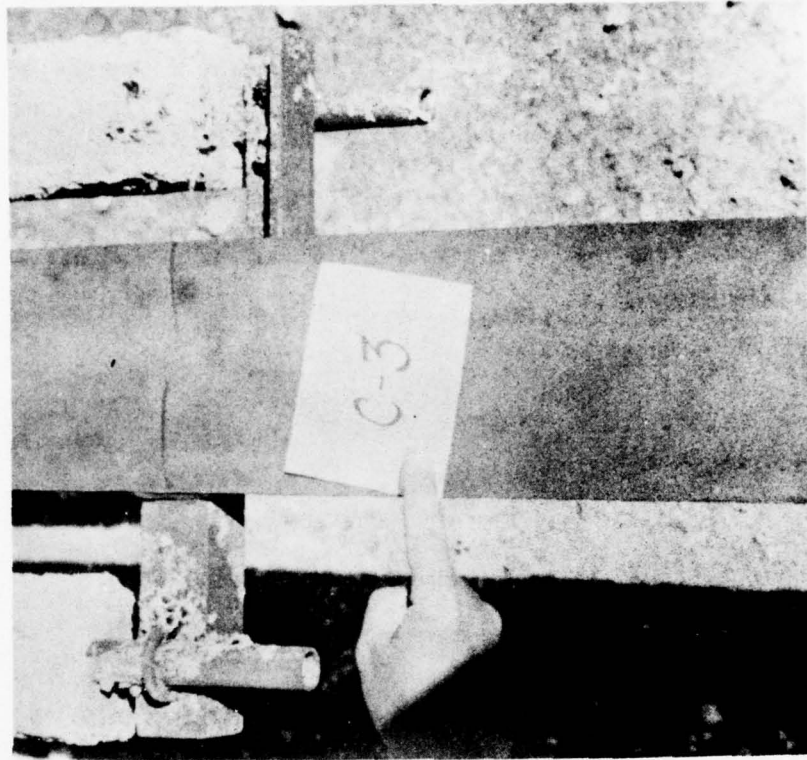

**Figure A7.** Bare carbon steel with aluminum anodes after 5-year removal. Protection afforded by sacrificial anodes is evidenced by lack of damage to immersed zone.



Figure A8. Typical fouling in the immersed zone.



Figure A9. Aluminum-pigmented epoxy tar after sandblasting. Pitting is evidence of damage in the immersed zone.



**Figure A10.** Epoxy-tar over zinc-rich primer after sandblasting. Severe pitting in the immersed zone is indication of structural degradation caused by corrosion.

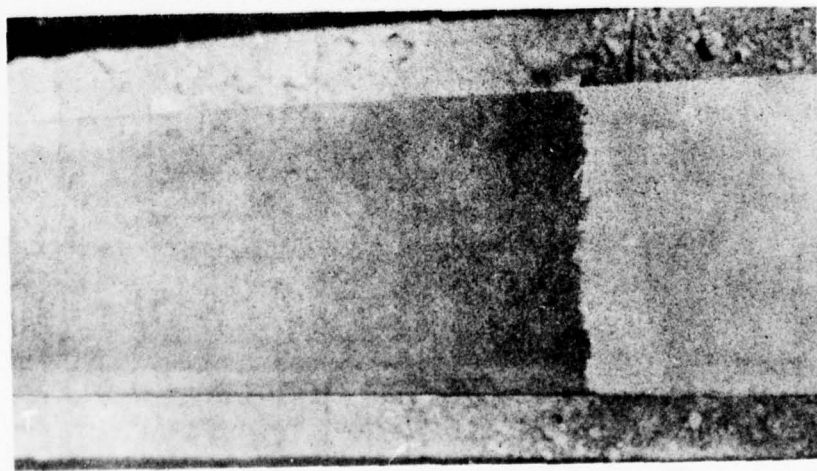

**Figure A11.** Polyester glassflake. Coating and steel after coating removal are in excellent condition in all zones.

APPENDIX B:

CHARTS OF CORROSION  
BEHAVIOR OF STEEL PILINGS  
AT LACOSTA ISLAND, FL

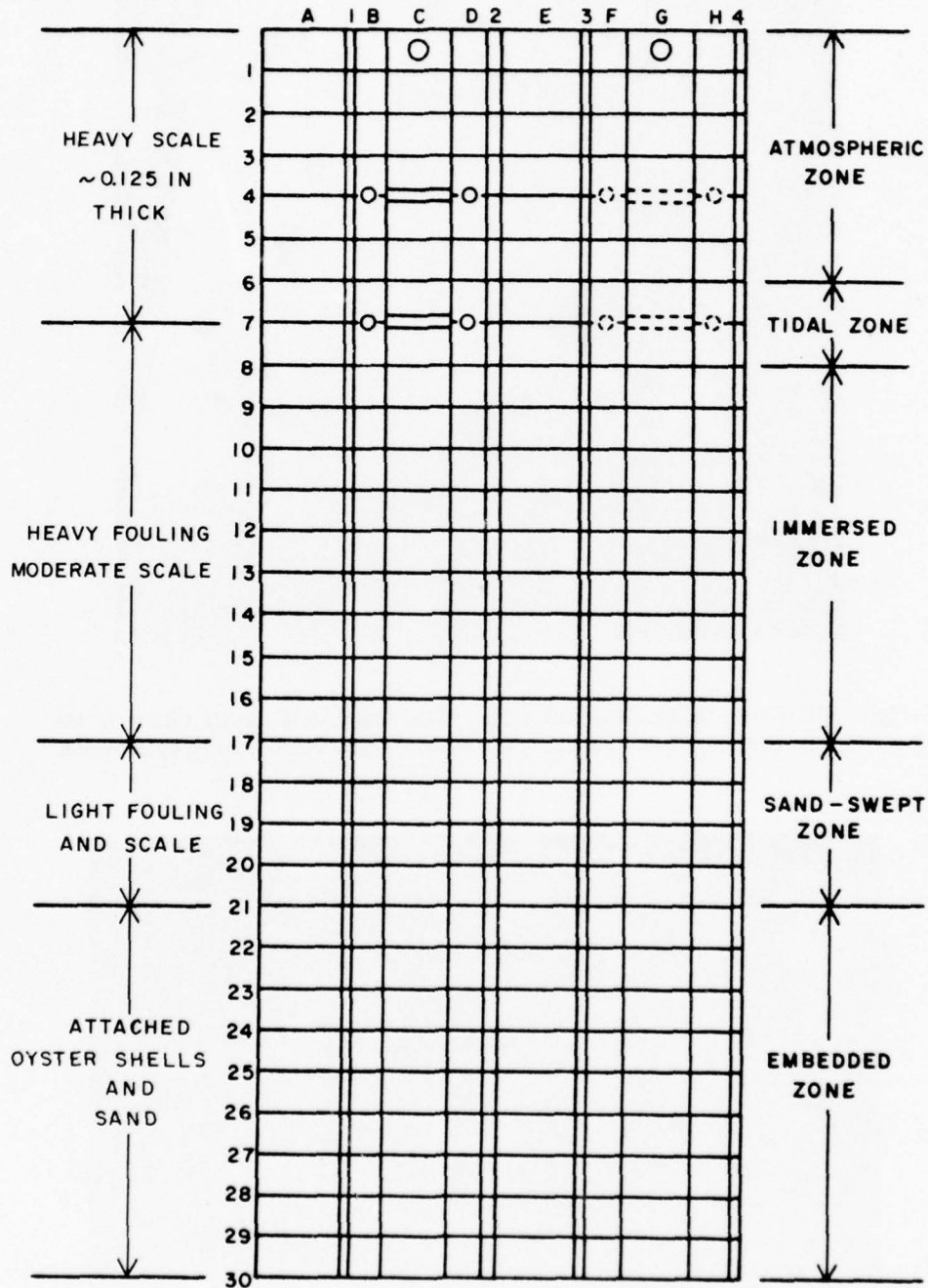

PILE NO. 1C  
BARE CARBON STEEL

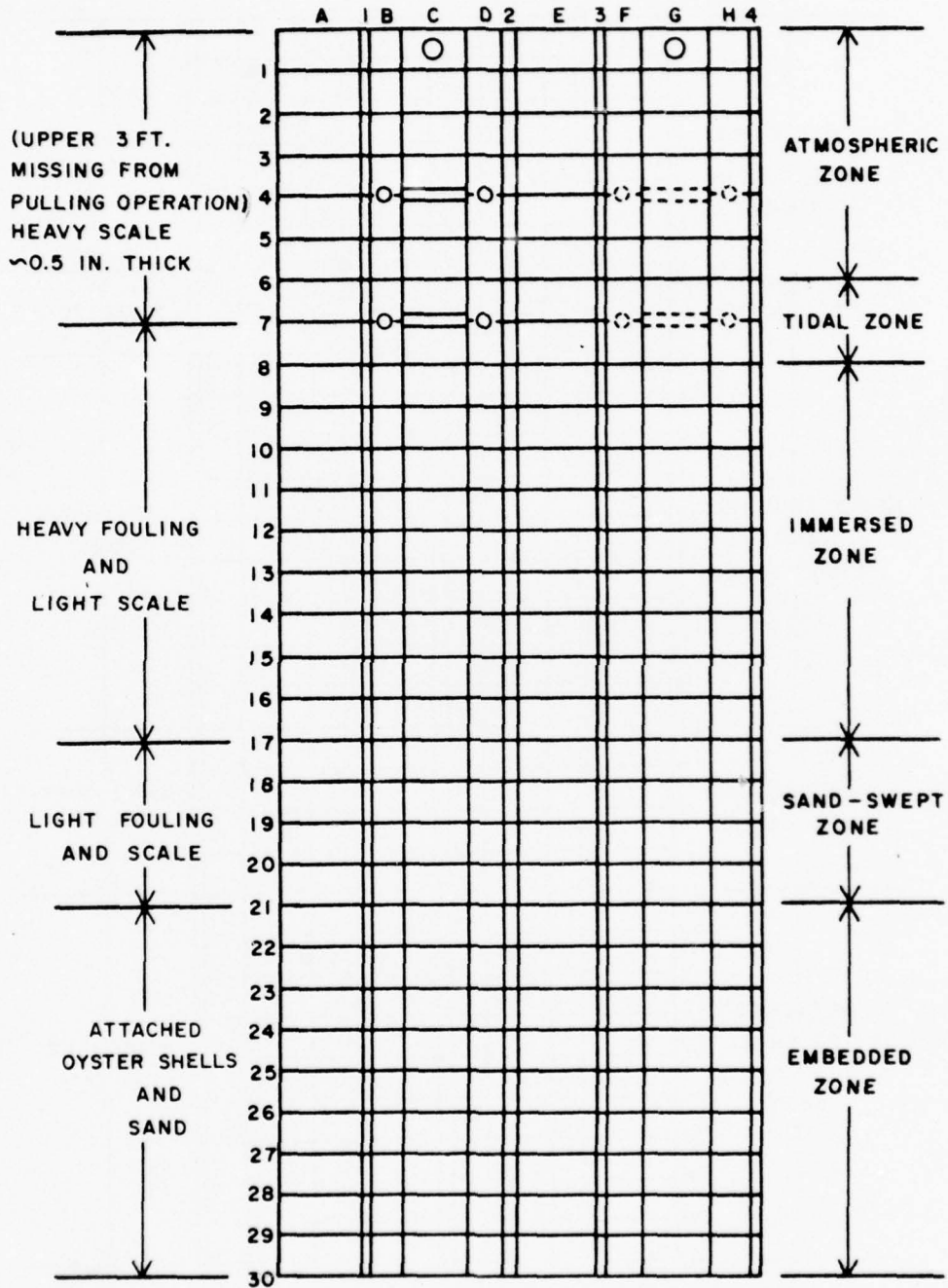

PILE NO. 2C  
 BARE CARBON STEEL W/ZINC ANODES

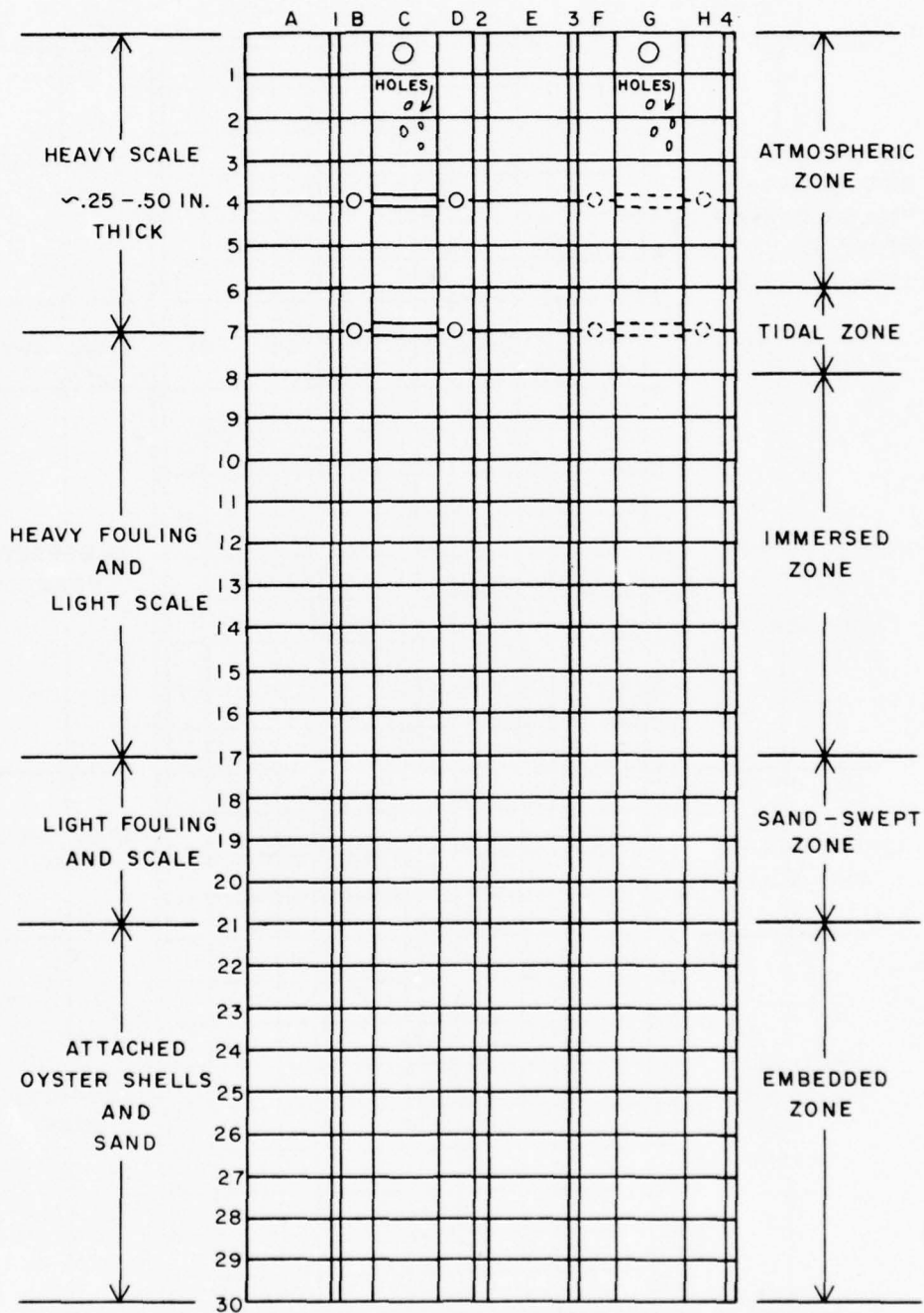

PILE NO. 3C  
BARE CARBON STEEL W/ALUMINUM ANODES

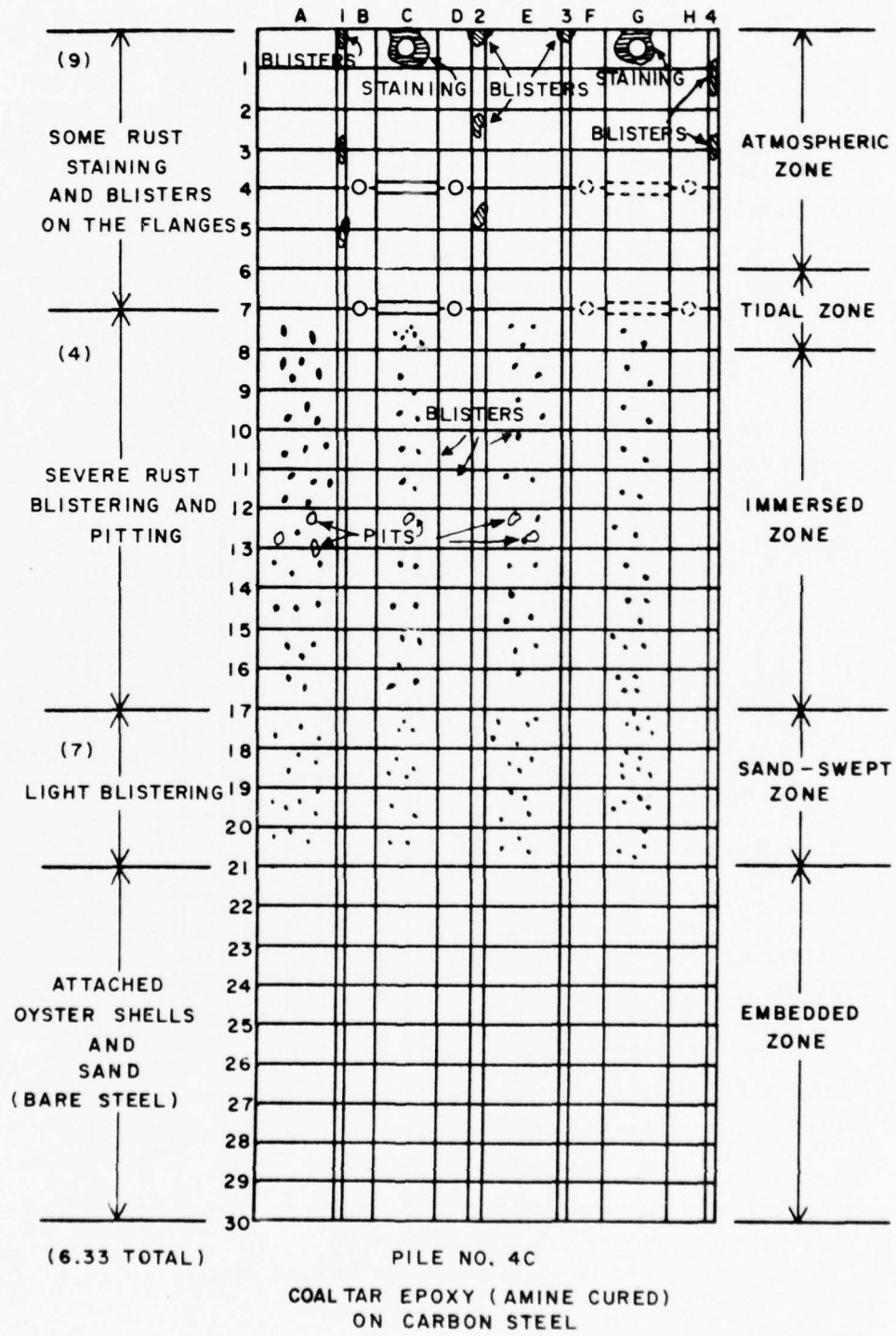

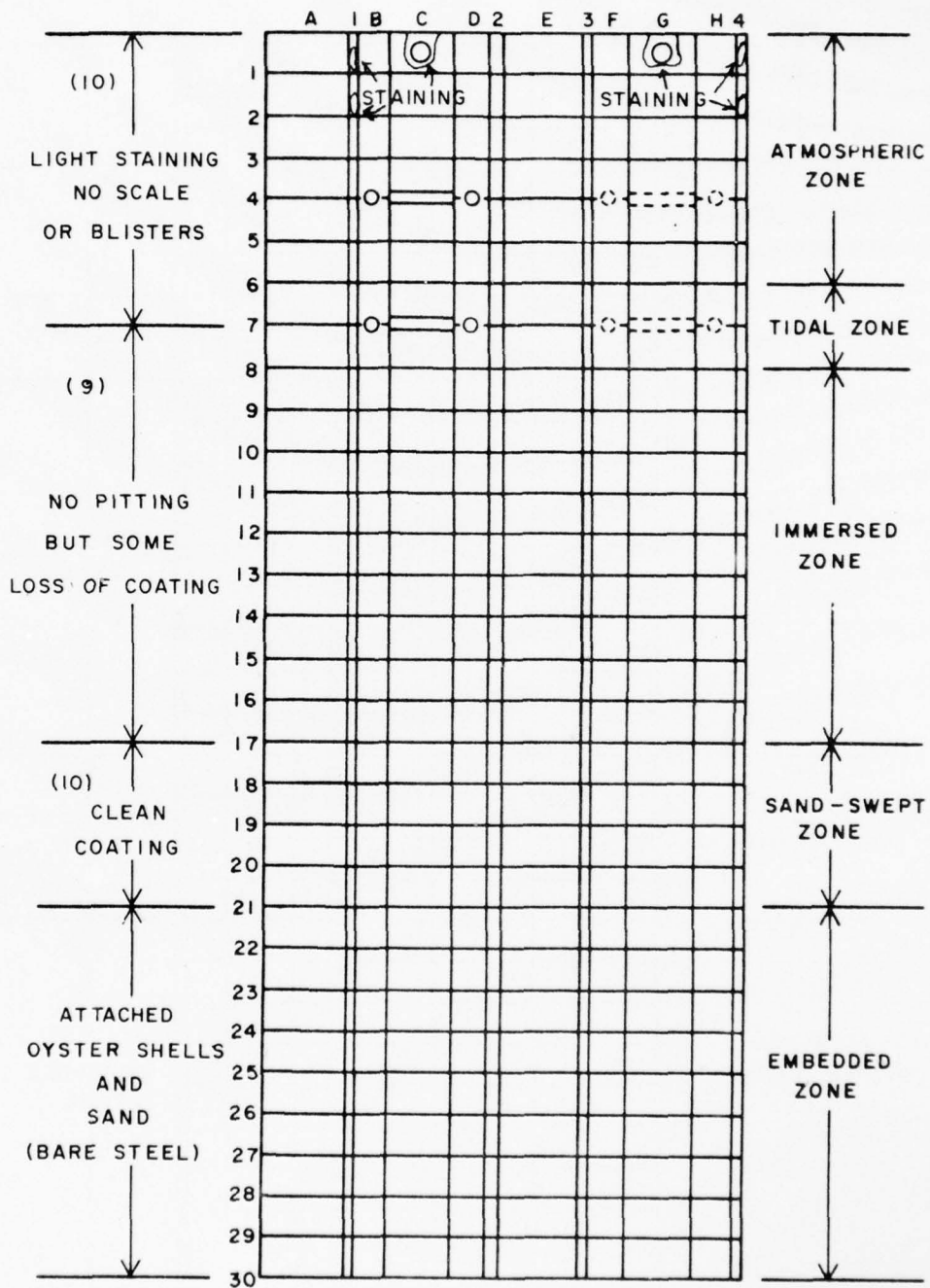

(9.67 TOTAL)

PILE NO. 5C  
 COAL TAR EPOXY ON CARBON STEEL  
 WITH ZINC ANODES

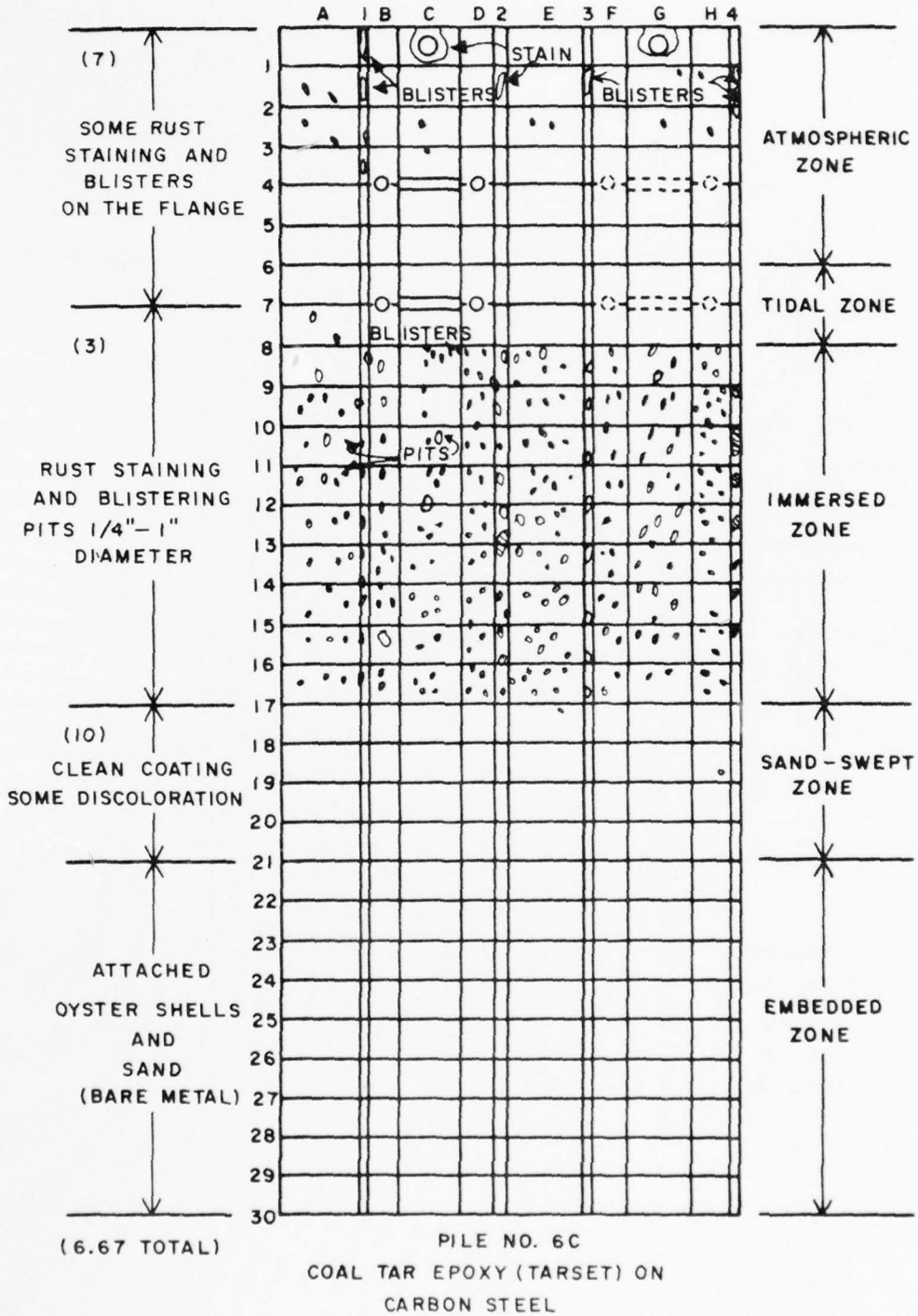

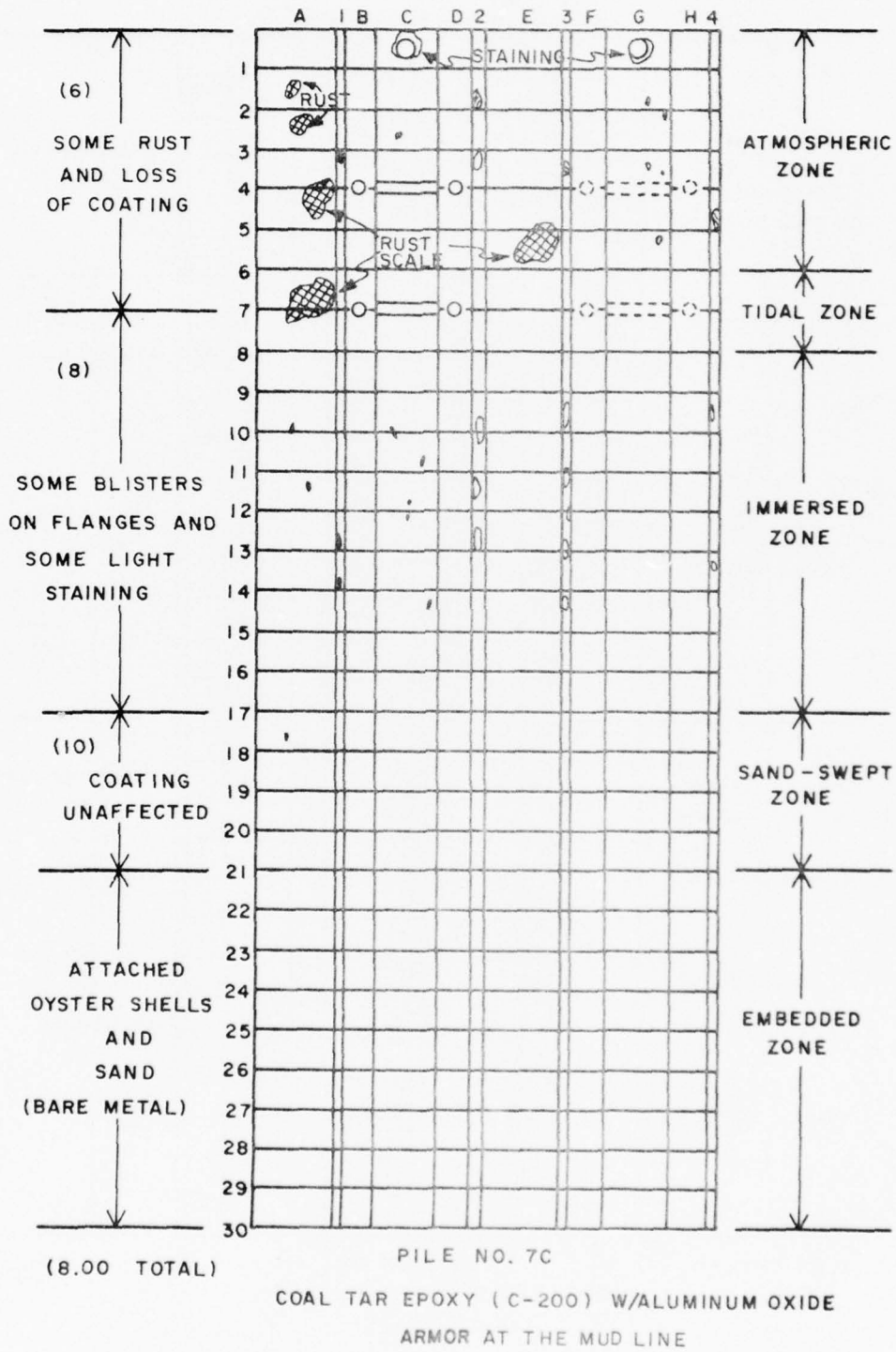

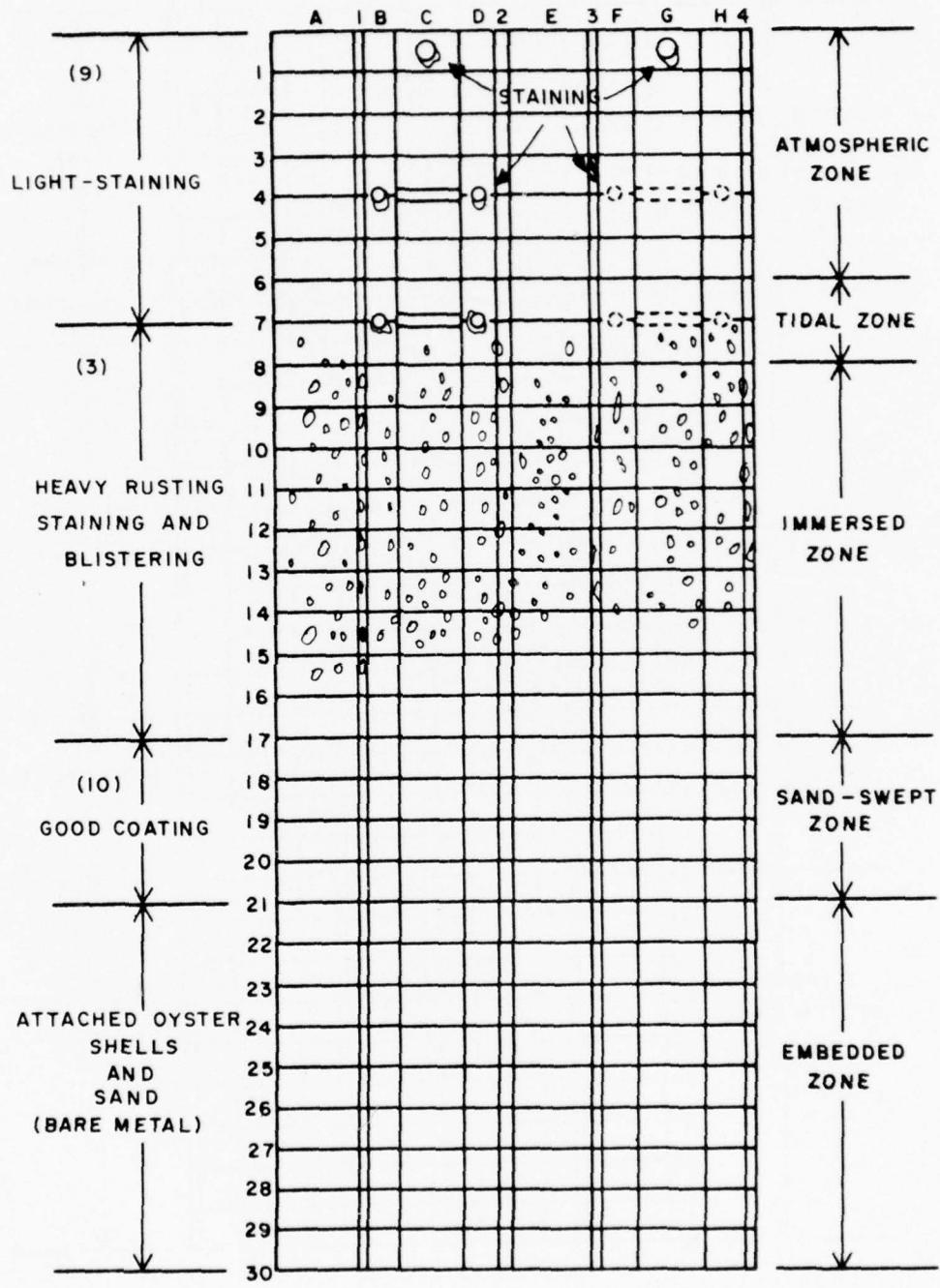

PILE NO. 8C  
 ALUMINUM PIGMENTED EPOXY-TAR  
 ON CARBON STEEL

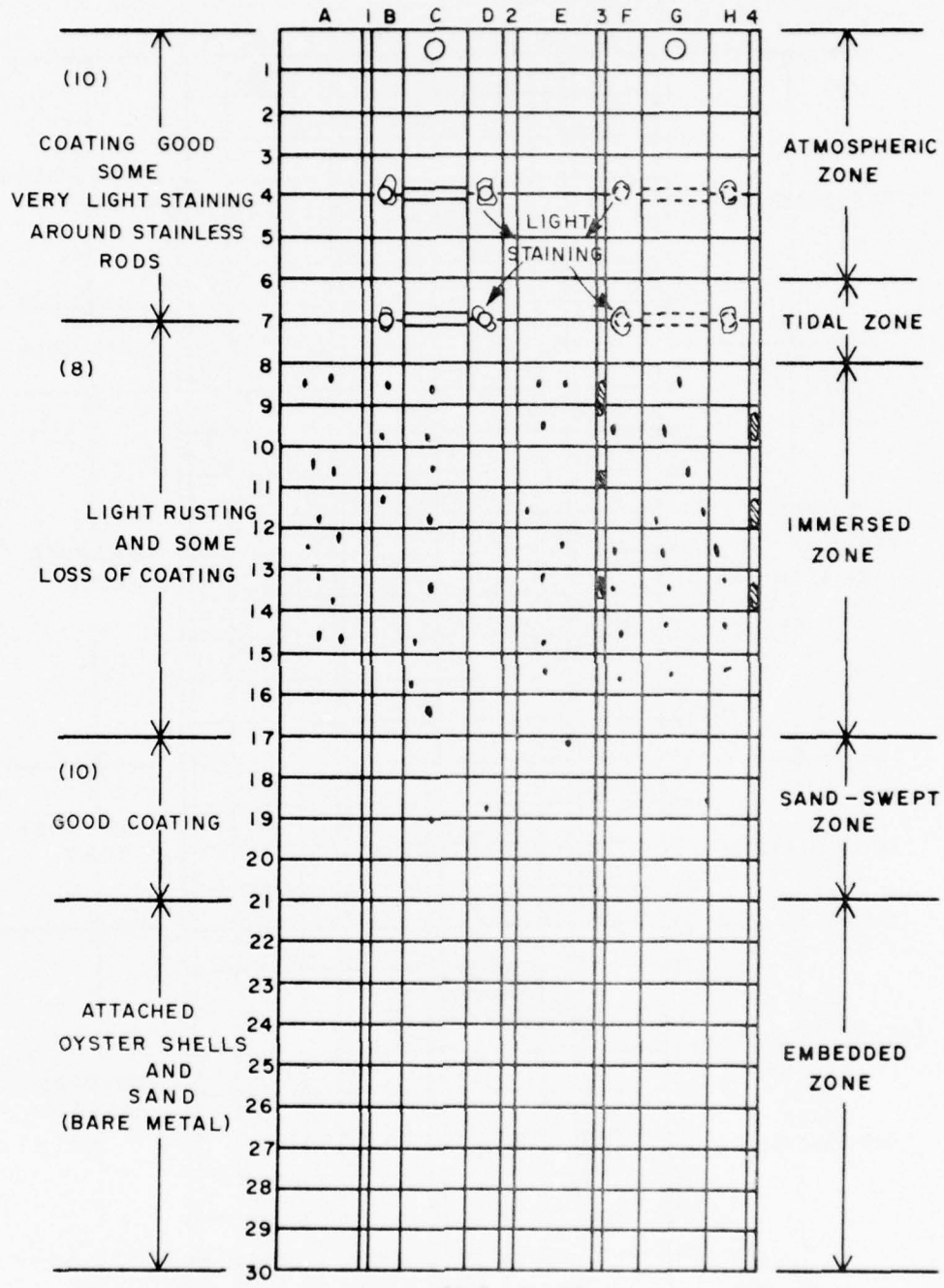

PILE NO. 9C  
 ALUMINUM PIGMENTED COAL TAR  
 (TARSET) EPOXY ON CARBON STEEL

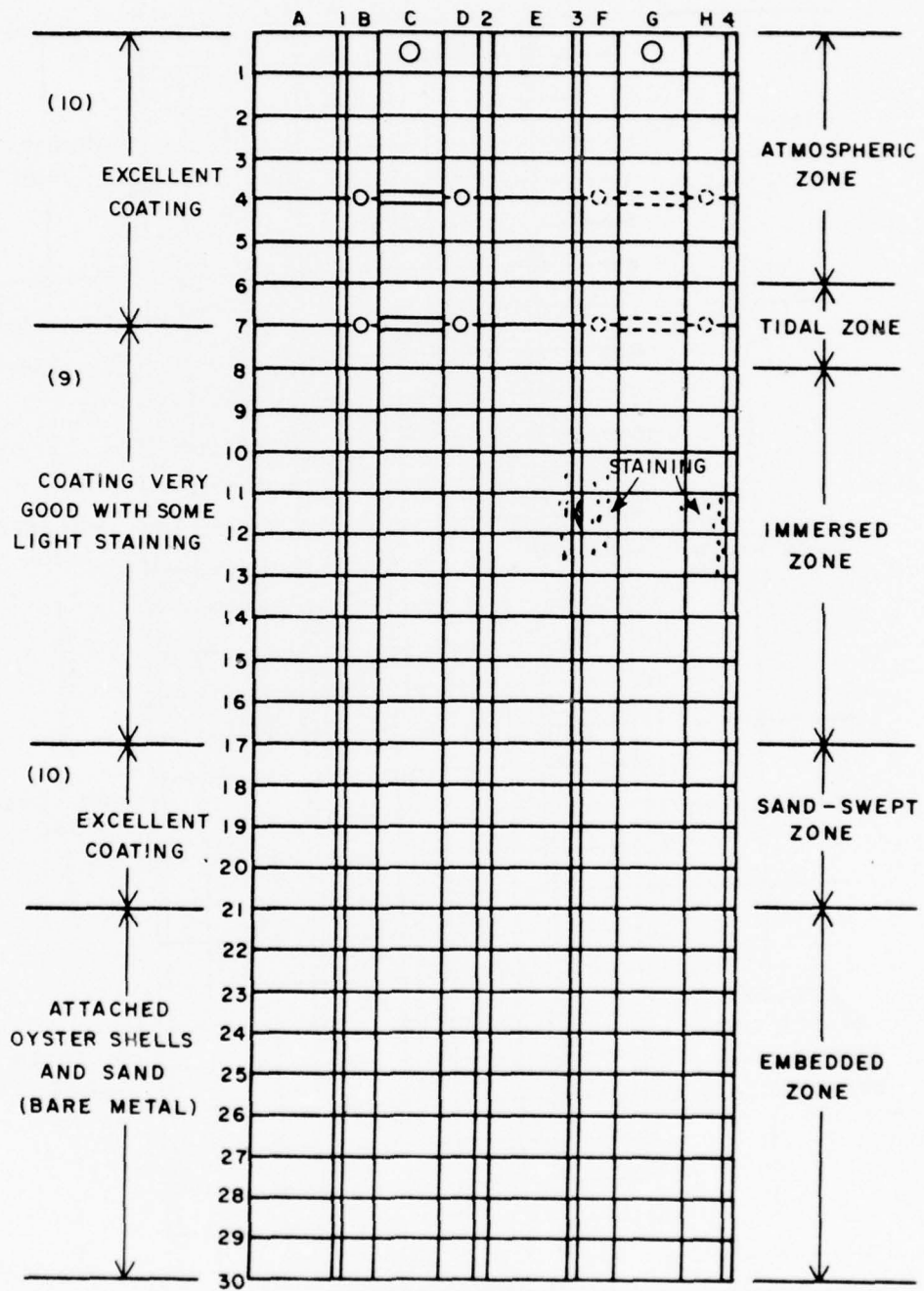

(9.67 TOTAL)

PILE NO. 10C

PLAS-CHEM 2140Z EPOXY OVER INORGANIC  
 CERAM-ITE 101 W/ZINC-ITE B PRIMER

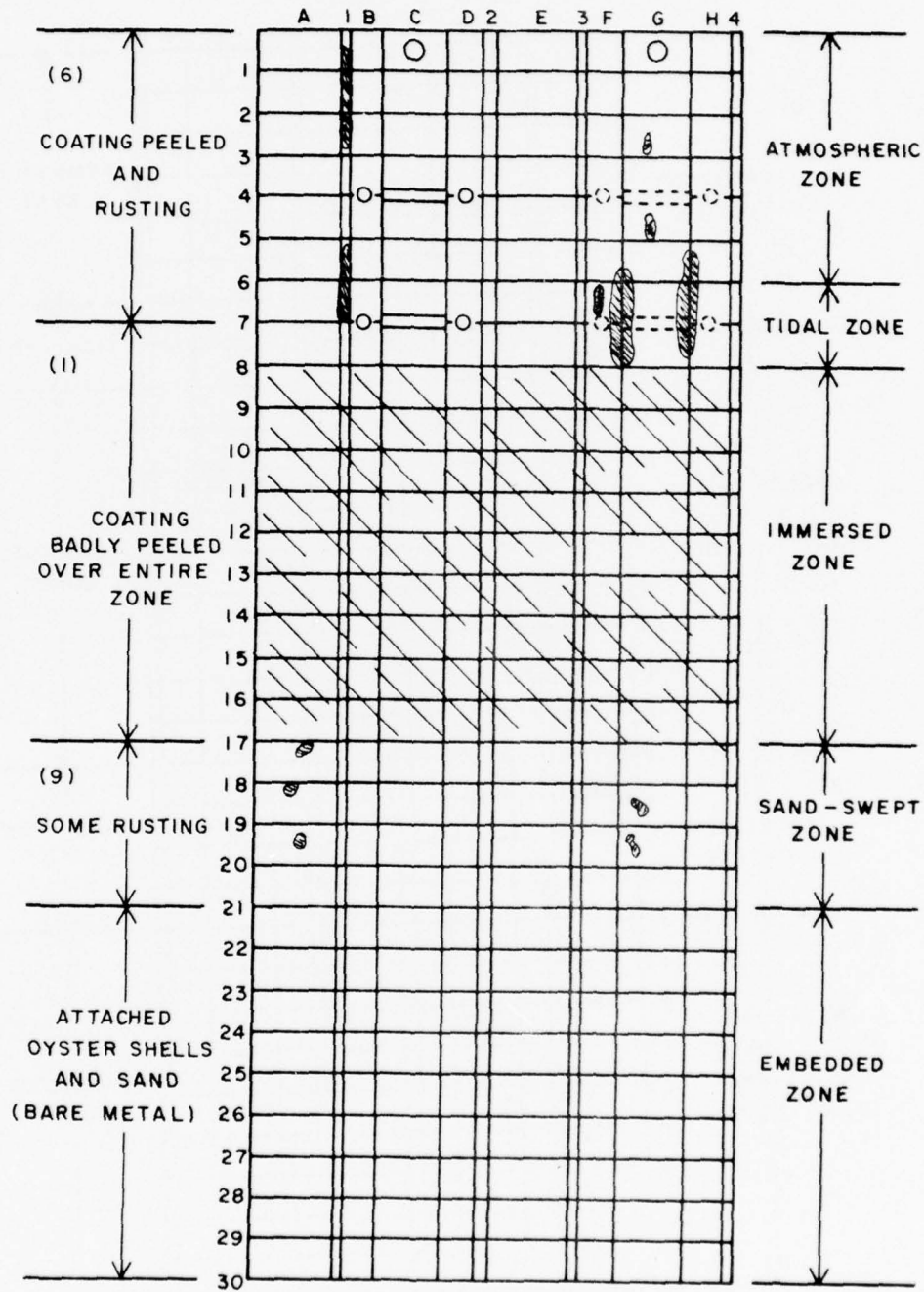

PILE NO. IIC  
EPOXY OVER INORGANIC ZINC PRIMER  
ON CARBON STEEL

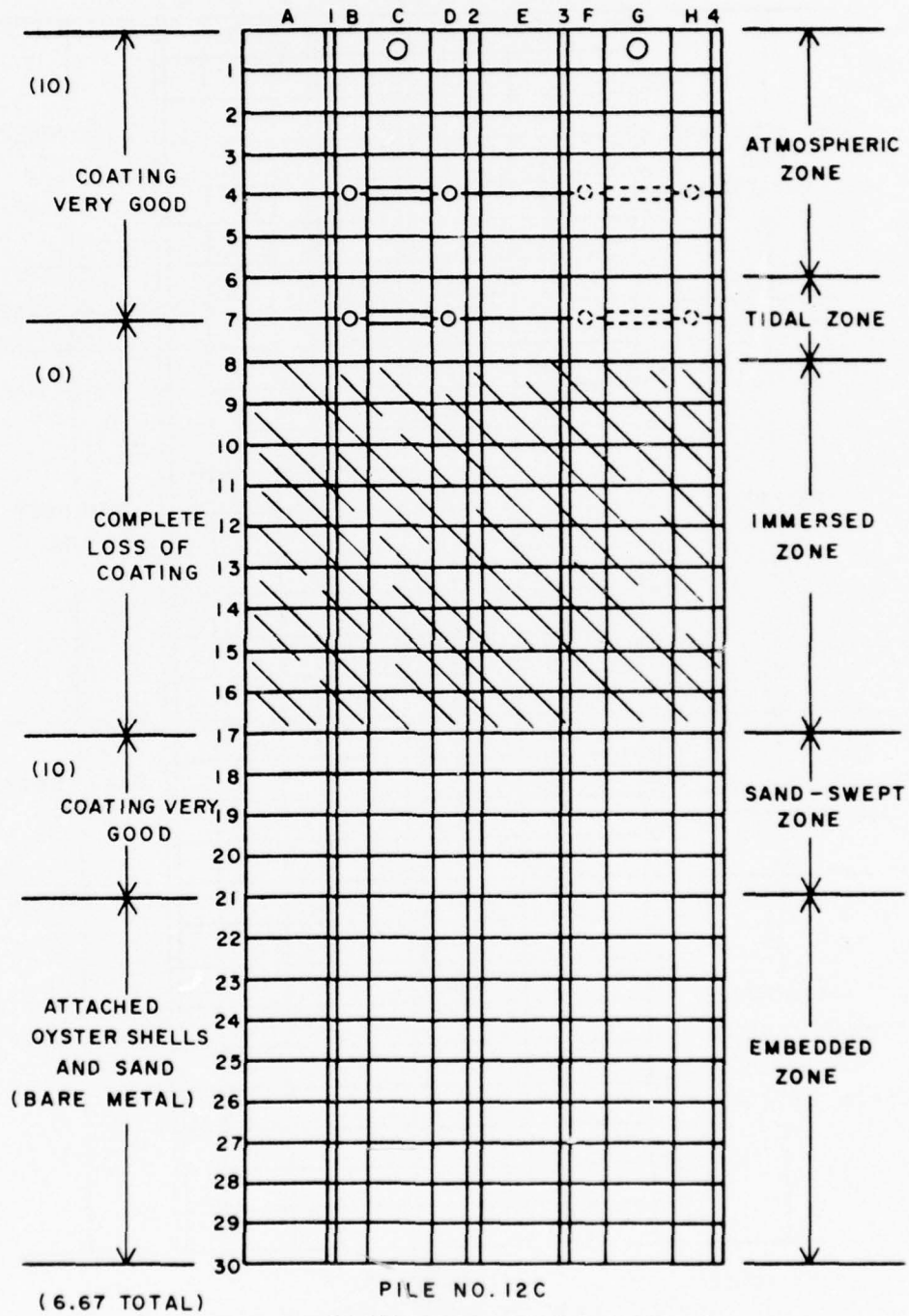

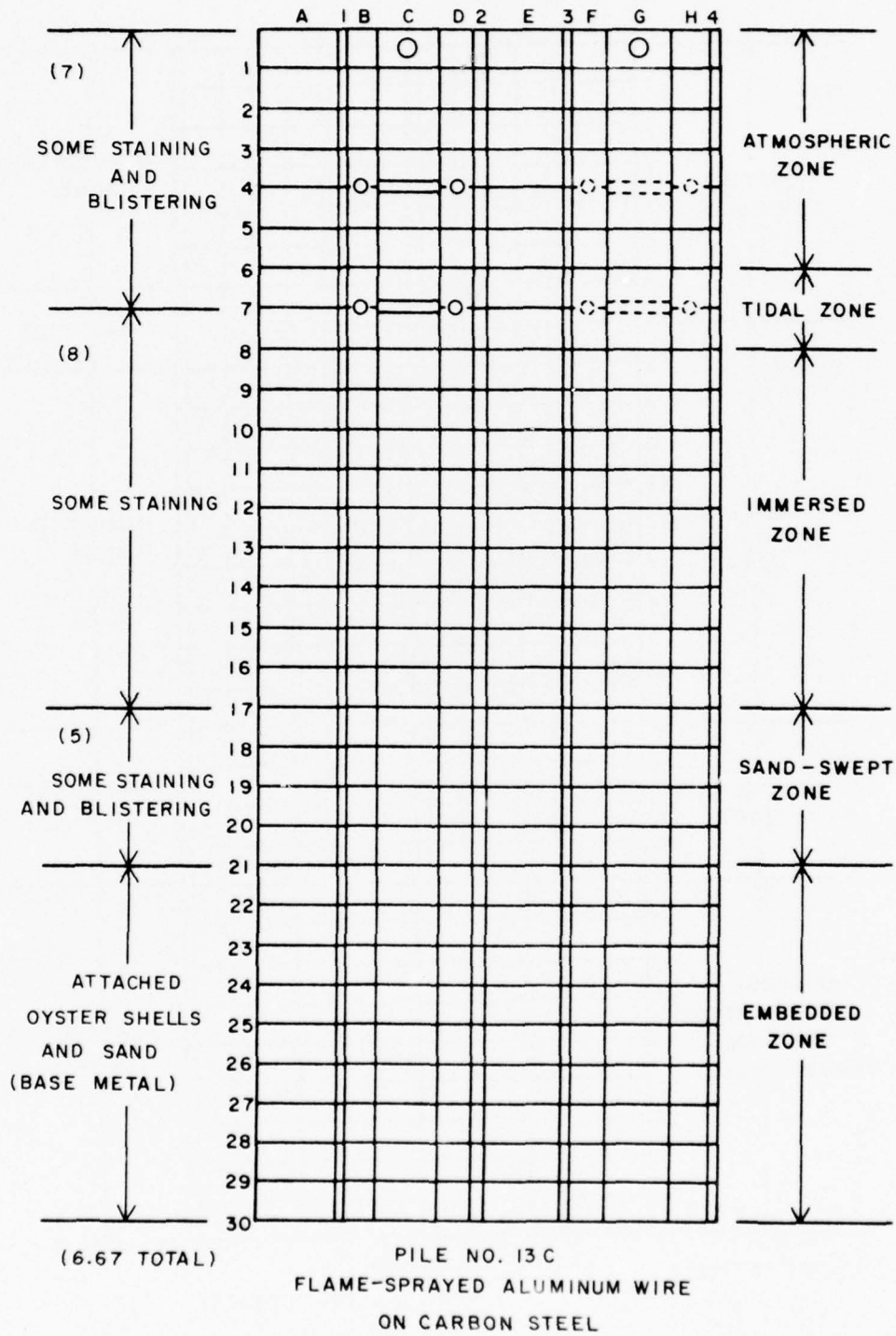

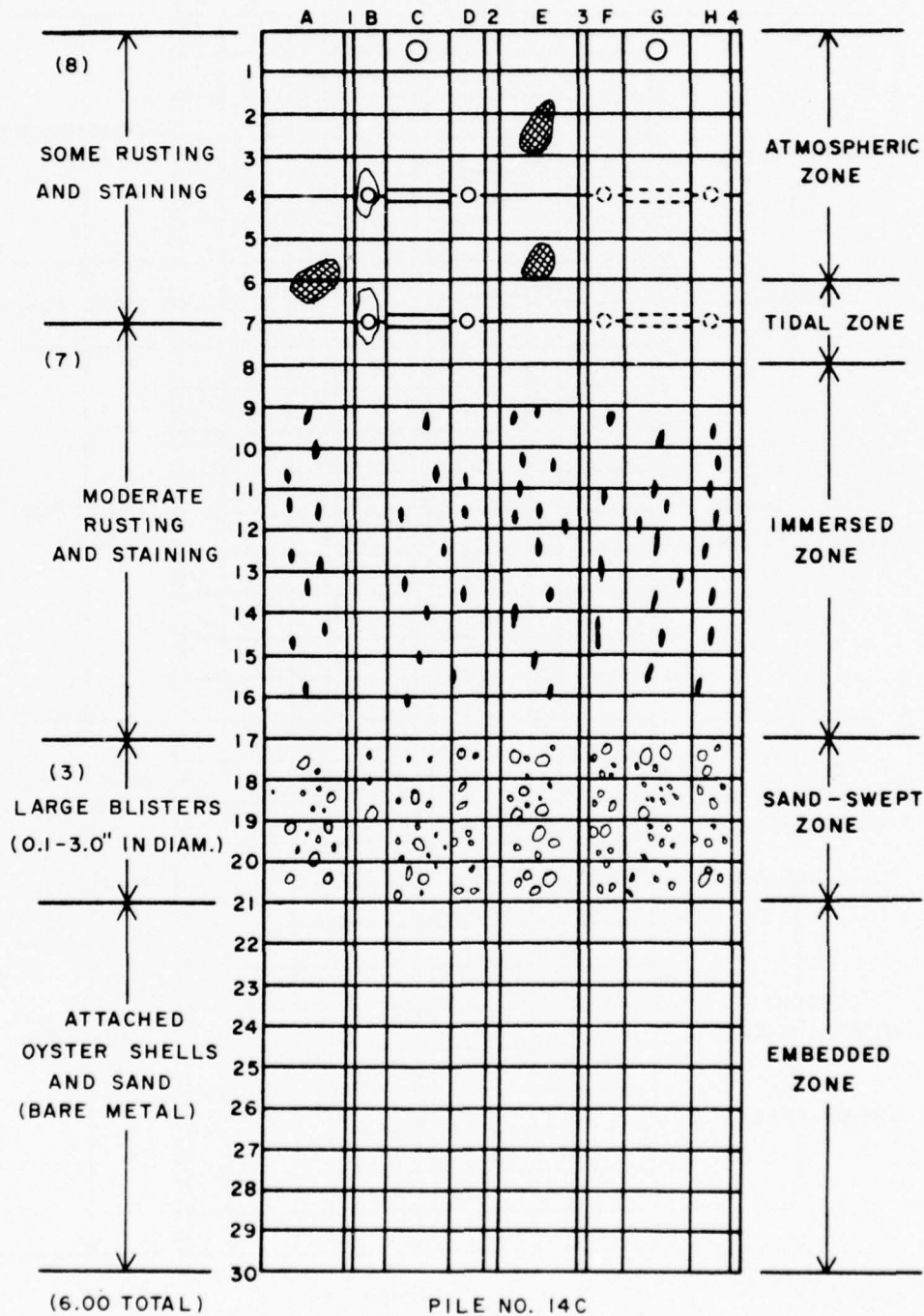

PILE NO. 14C  
 FLAME-SPRAYED ALUMINUM WIRE  
 W/VINYL TOPCOAT ON CARBON STEEL

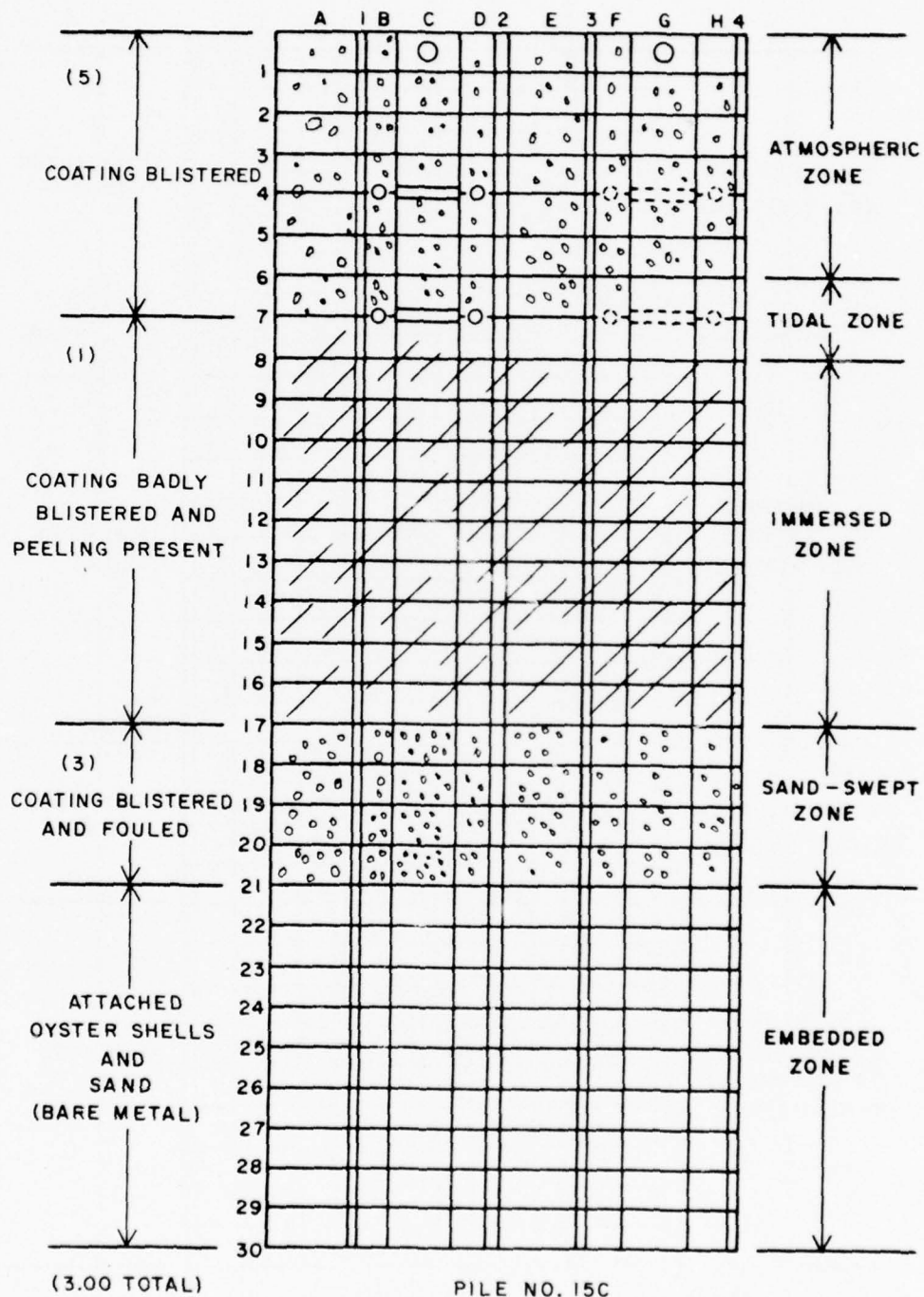

PILE NO. 15C  
 FLAME-SPRAYED ZINC WITH SARAN TOPCOAT  
 ON CARBON STEEL

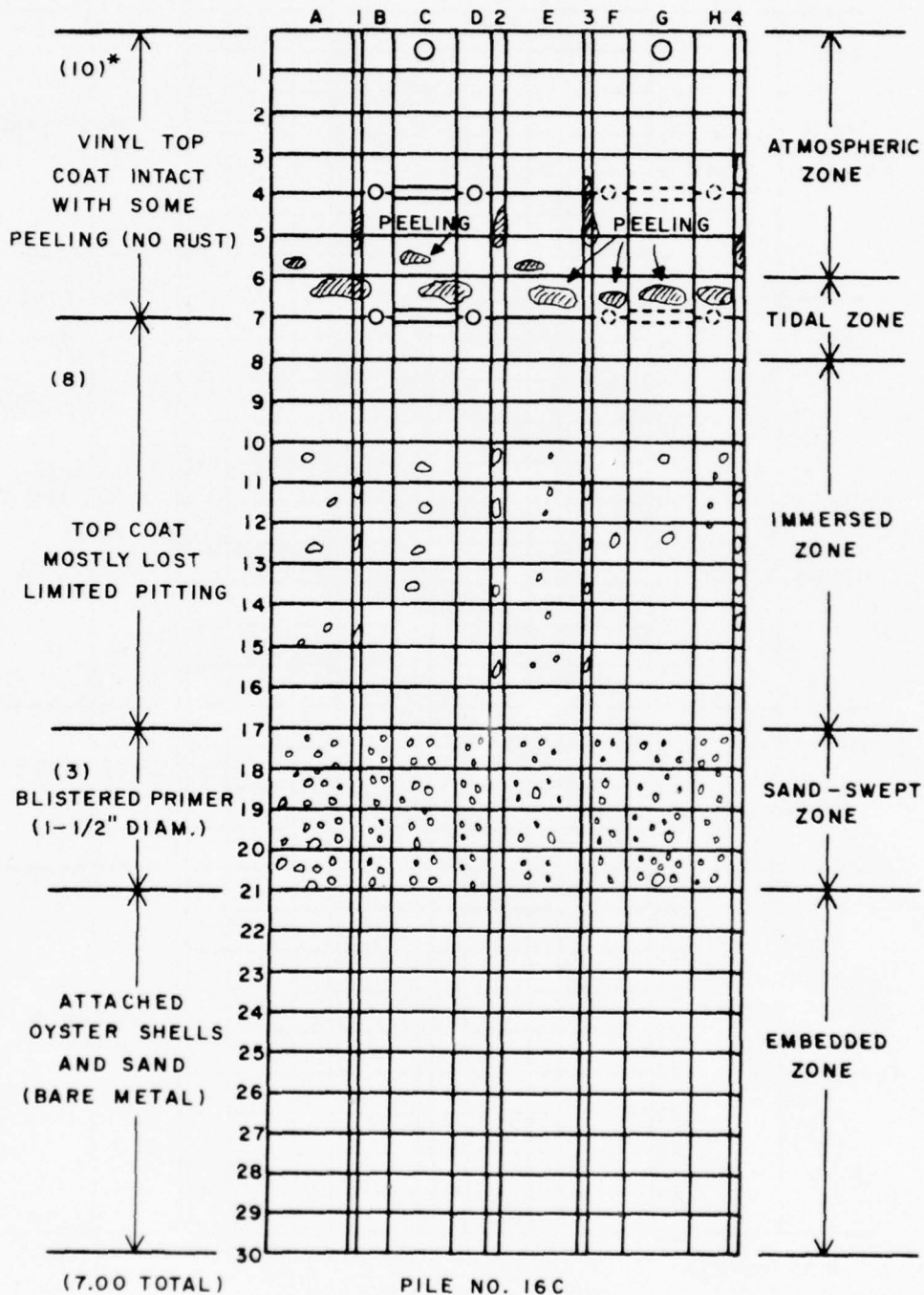

PILE NO. 16C  
 FLAME-SPRAYED ZINC WITH NAVY VINYL TOPCOAT  
 \*TOPCOAT HAD PEELED BUT NO RUST WAS PRESENT

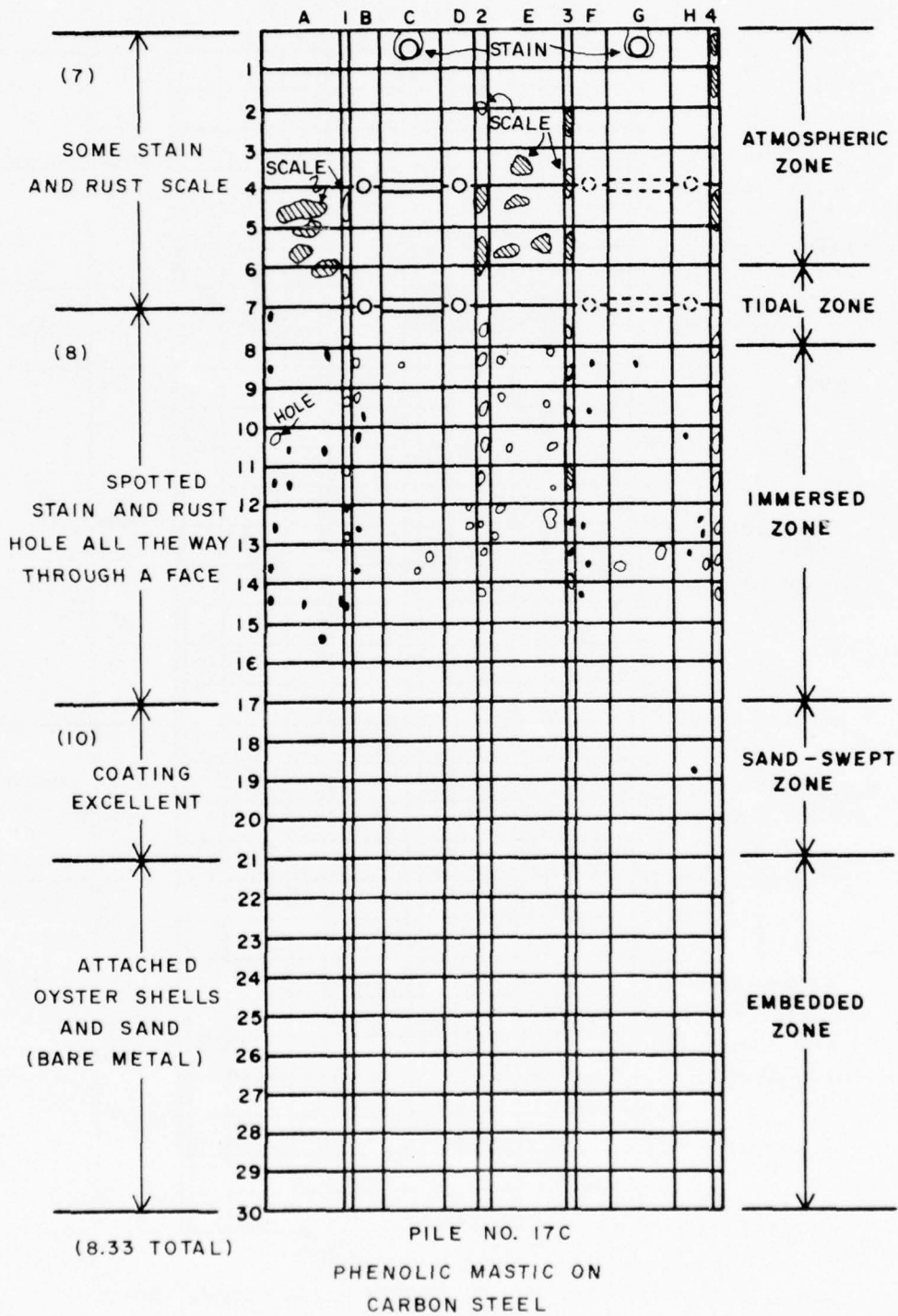

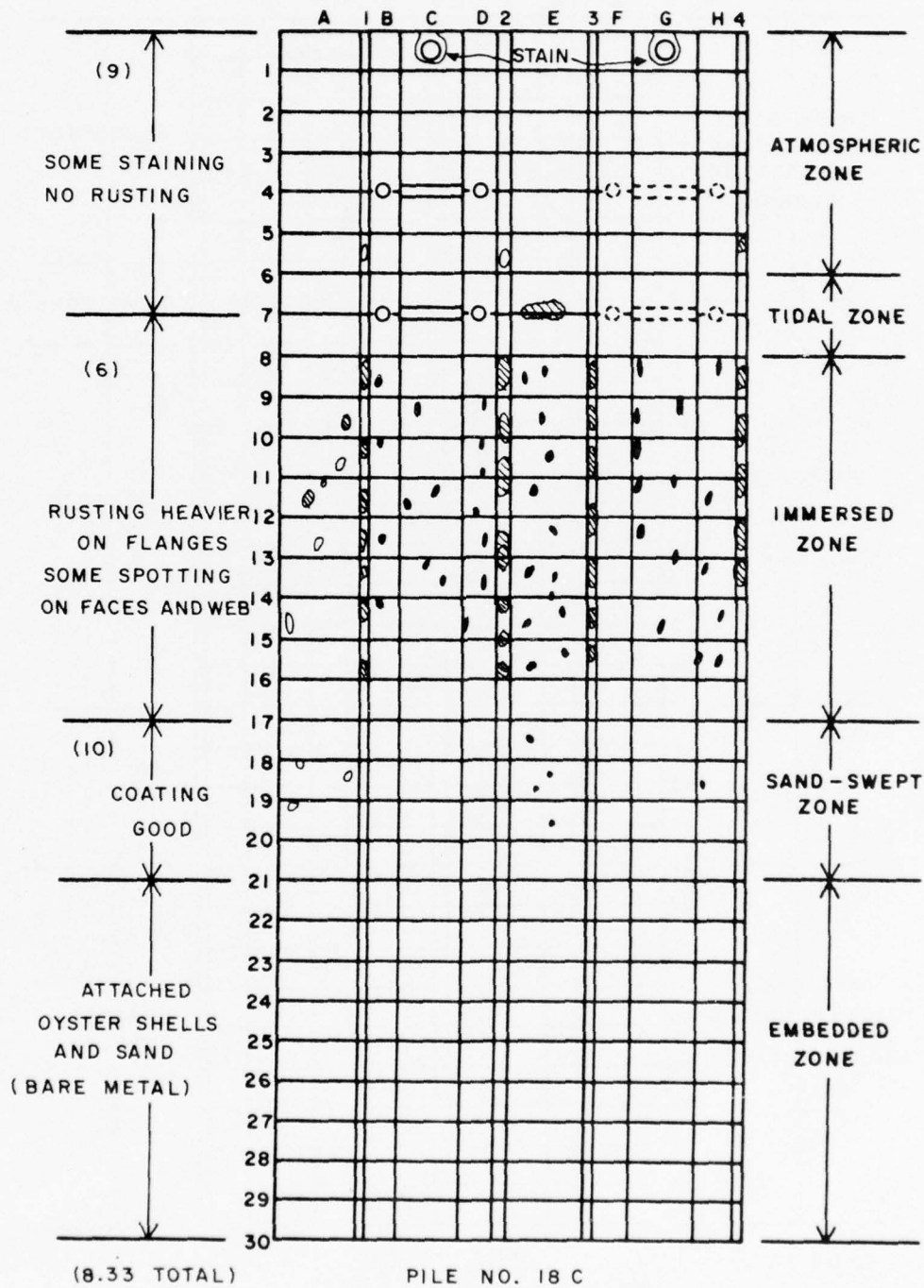

PILE NO. 18 C  
 COAL TAR EPOXY OVER INORGANIC ZINC-RICH  
 PRIMER ON CARBON STEEL

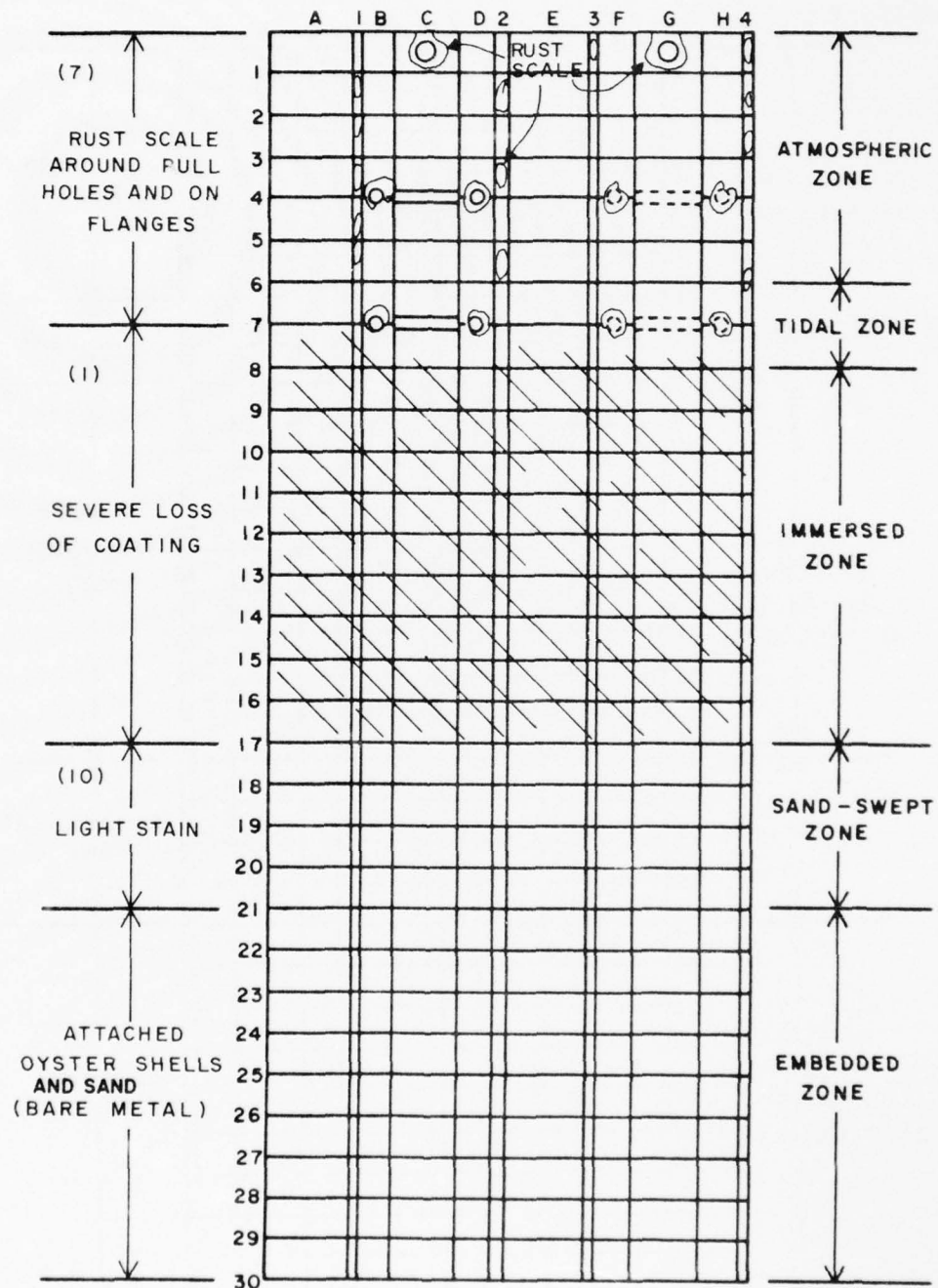

(7)  
 ↑  
 RUST SCALE  
 AROUND FULL  
 HOLES AND ON  
 FLANGES

(1)  
 ↓  
 SEVERE LOSS  
 OF COATING

(10)  
 ↓  
 LIGHT STAIN

ATTACHED  
 OYSTER SHELLS  
 AND SAND  
 (BARE METAL)

(6.00 TOTAL)

↑  
 ATMOSPHERIC  
 ZONE

↓  
 TIDAL  
 ZONE

↓  
 IMMERSED  
 ZONE

↓  
 SAND-SWEPT  
 ZONE

↓  
 EMBEDDED  
 ZONE

PILE NO. 19C

VINYL OVER INORGANIC ZINC-RICH PRIMER  
 ON CARBON STEEL

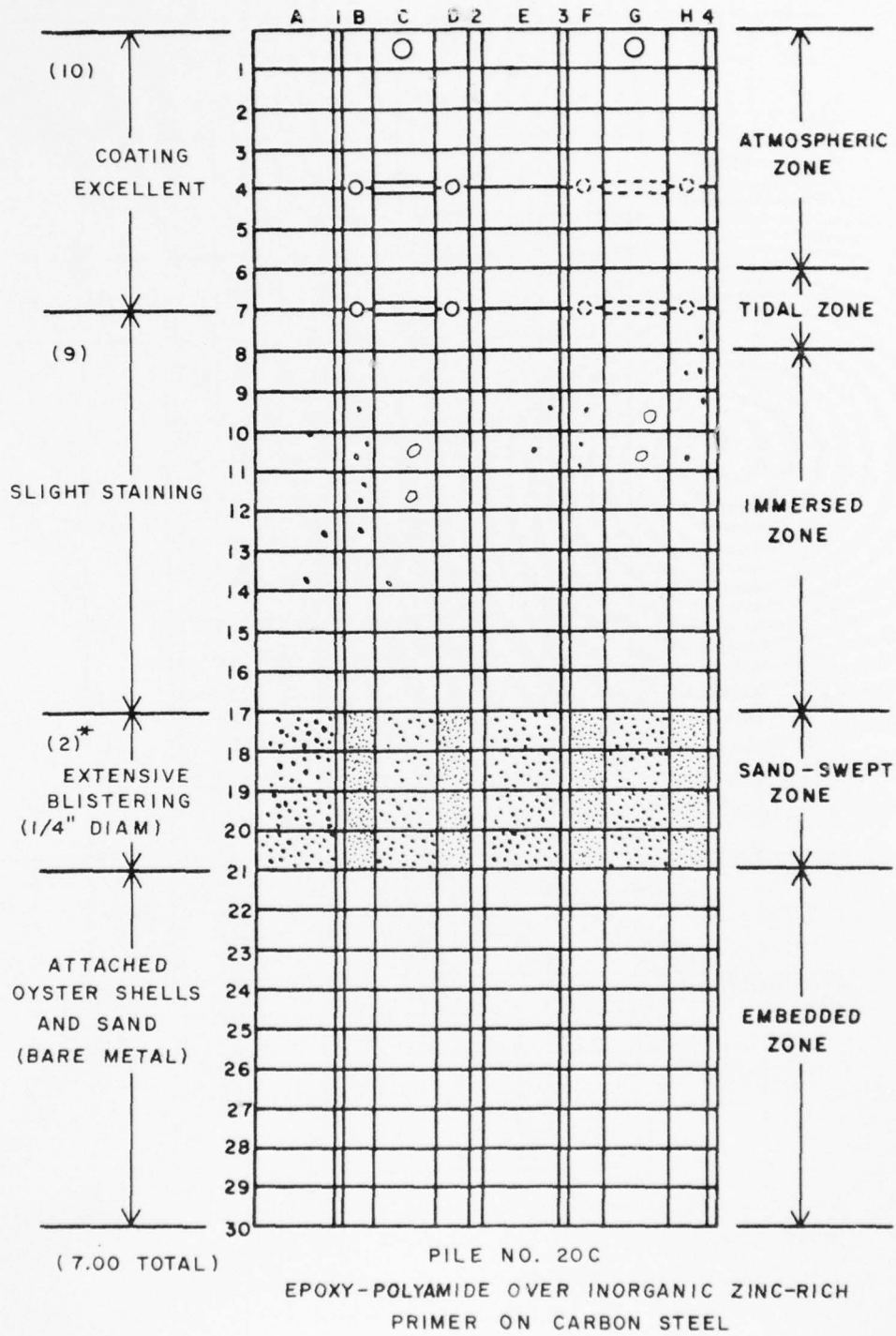

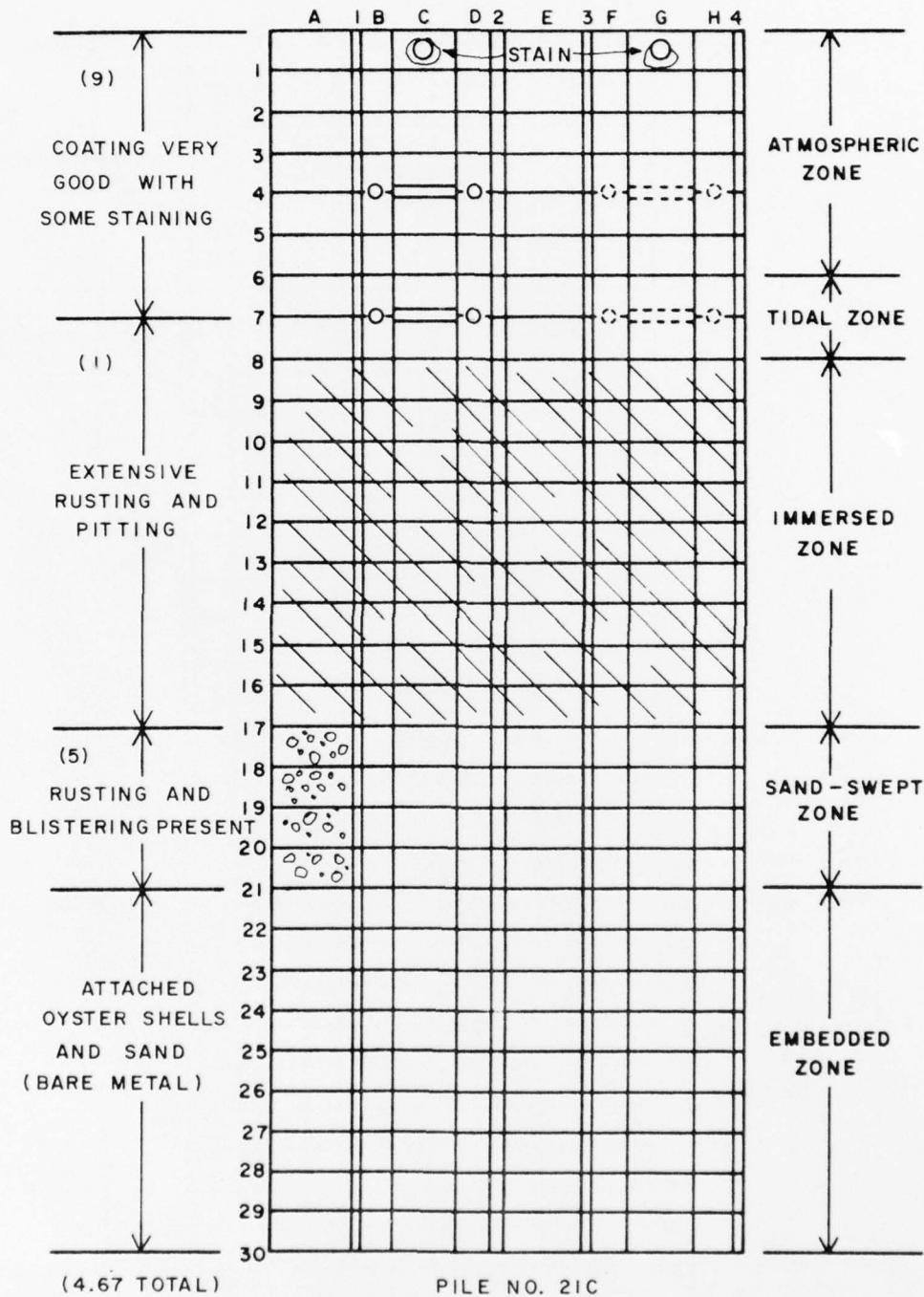

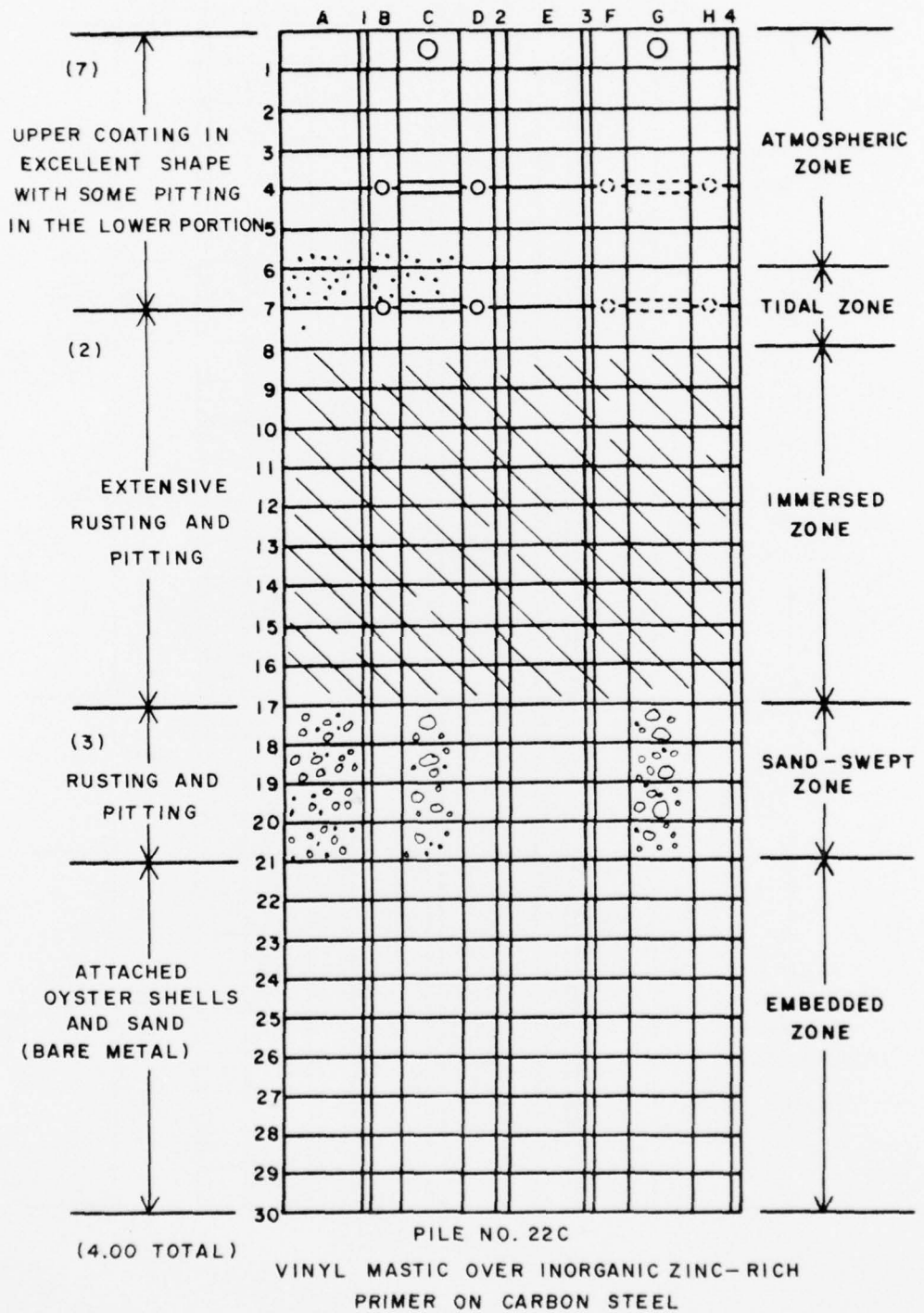

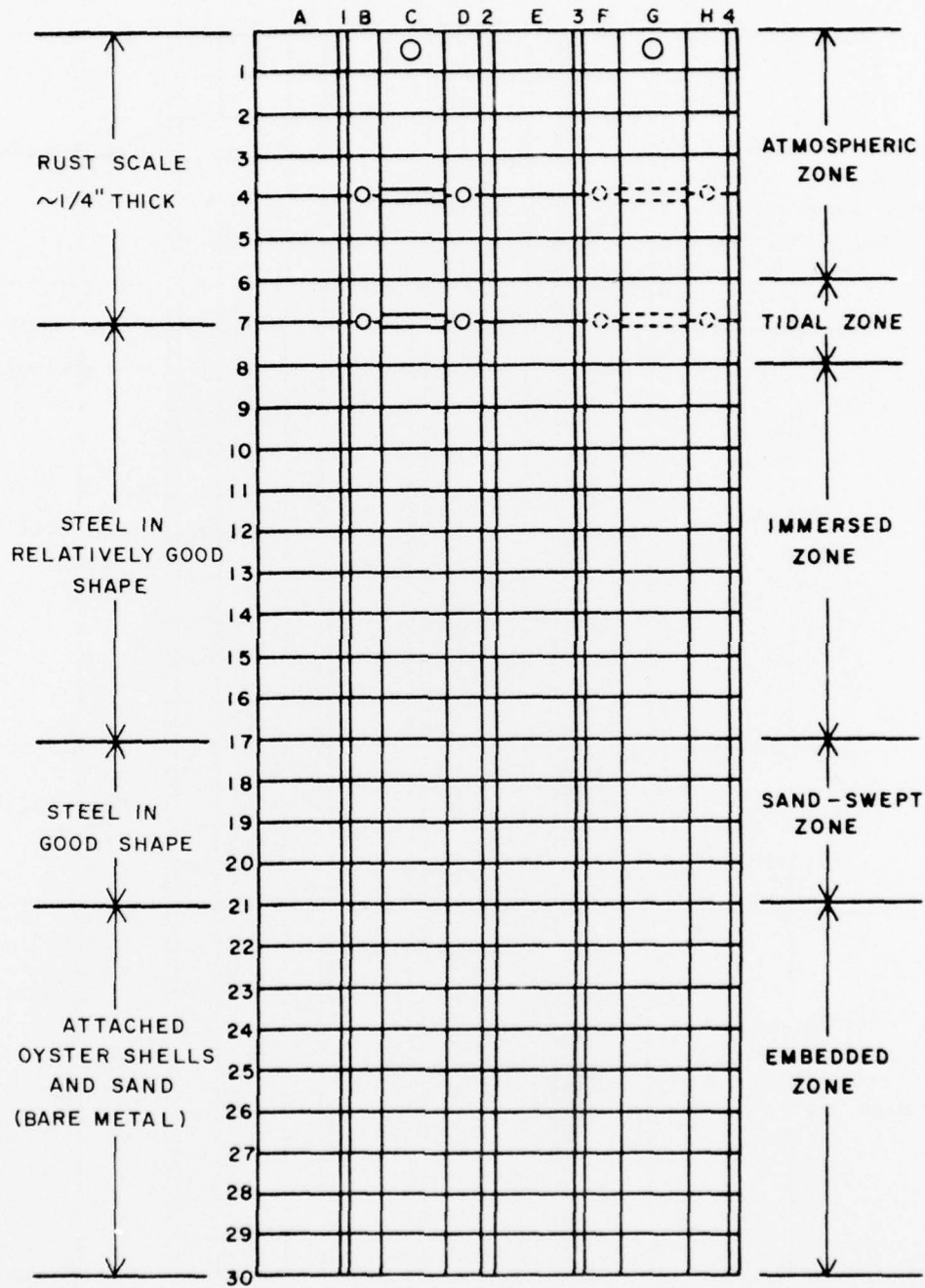

PILE NO. 23C  
BARE MARINER STEEL

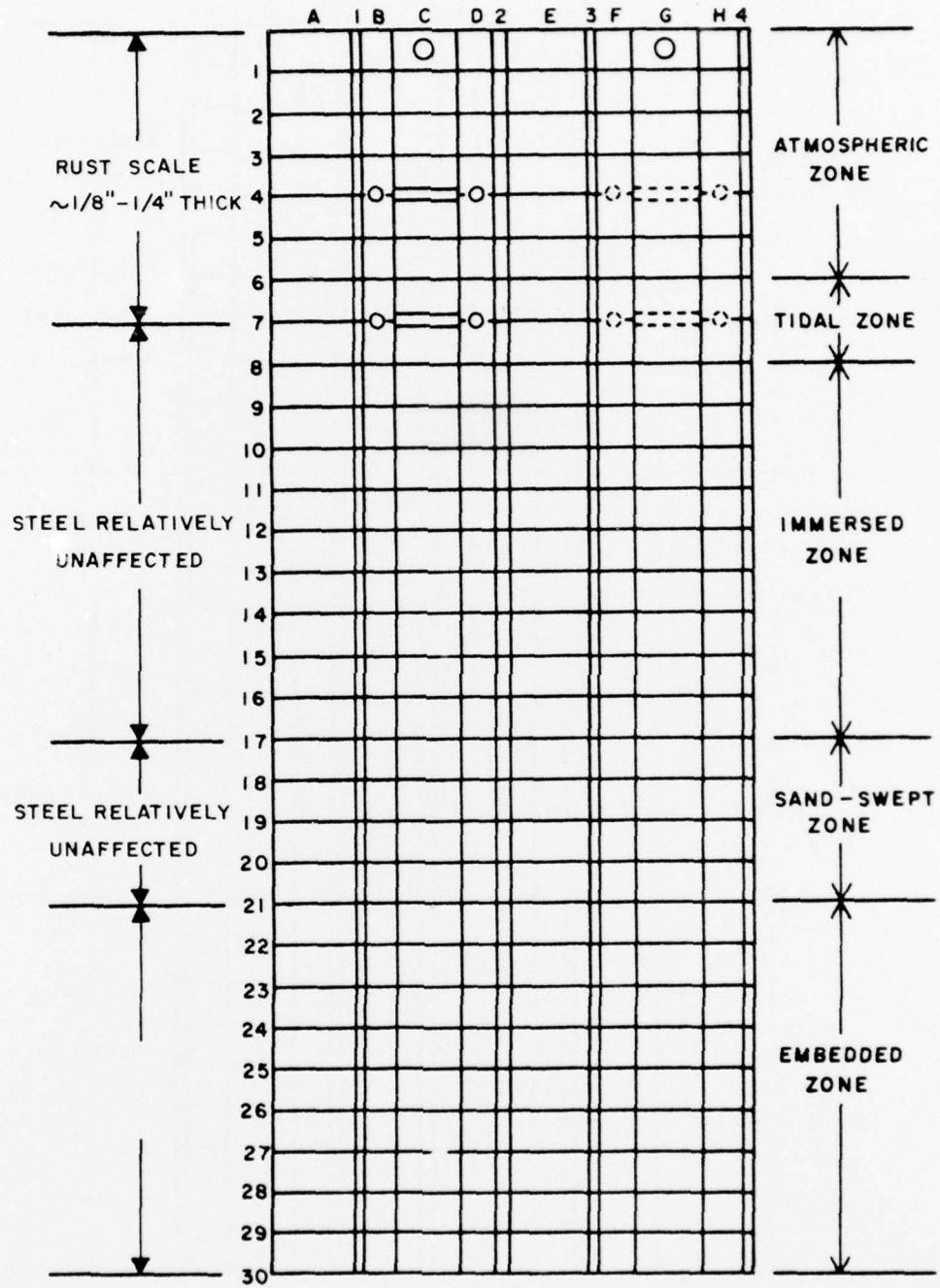

PILE NO. 24 C  
 BARE MARINER STEEL W/ZINC ANODES

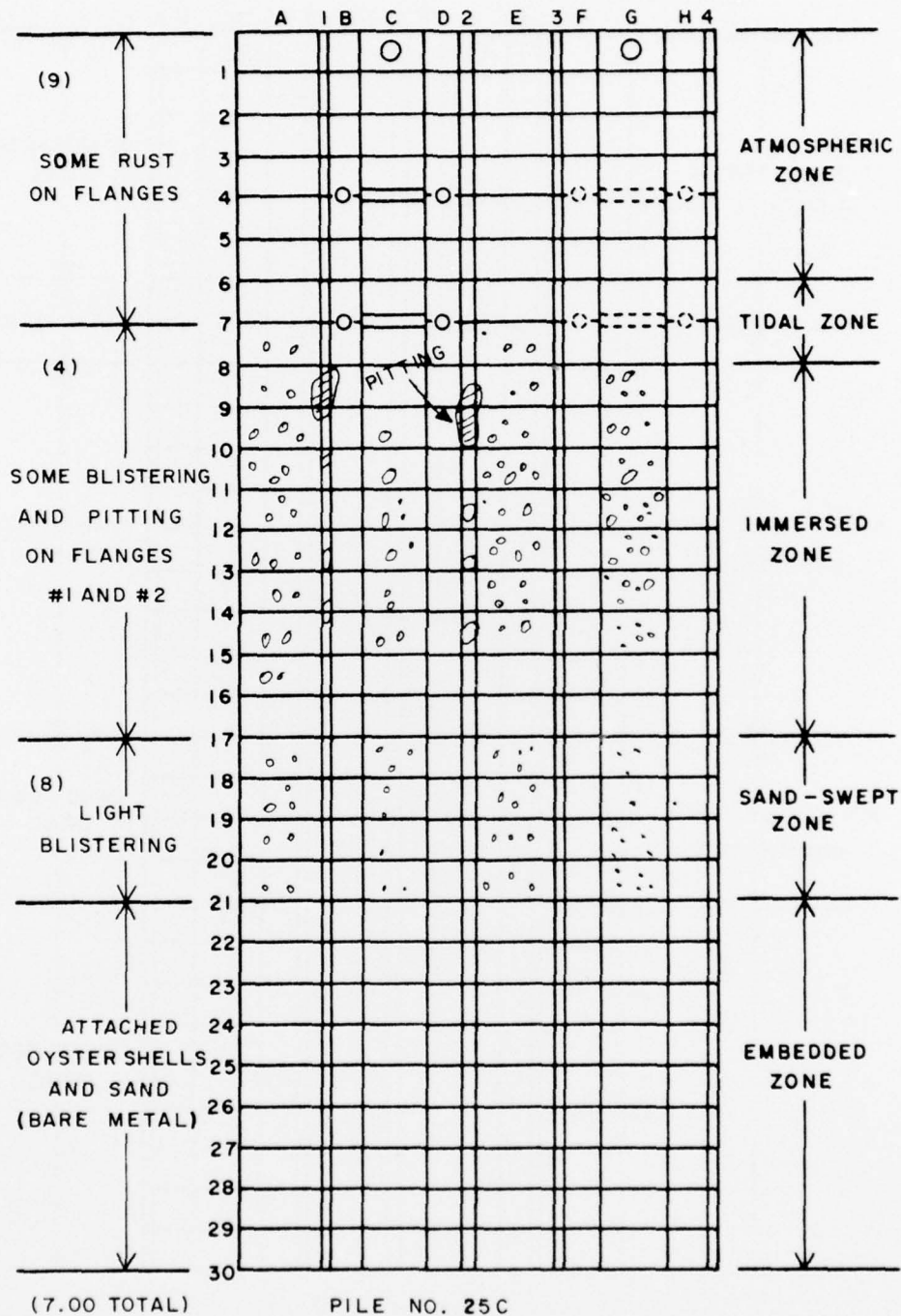

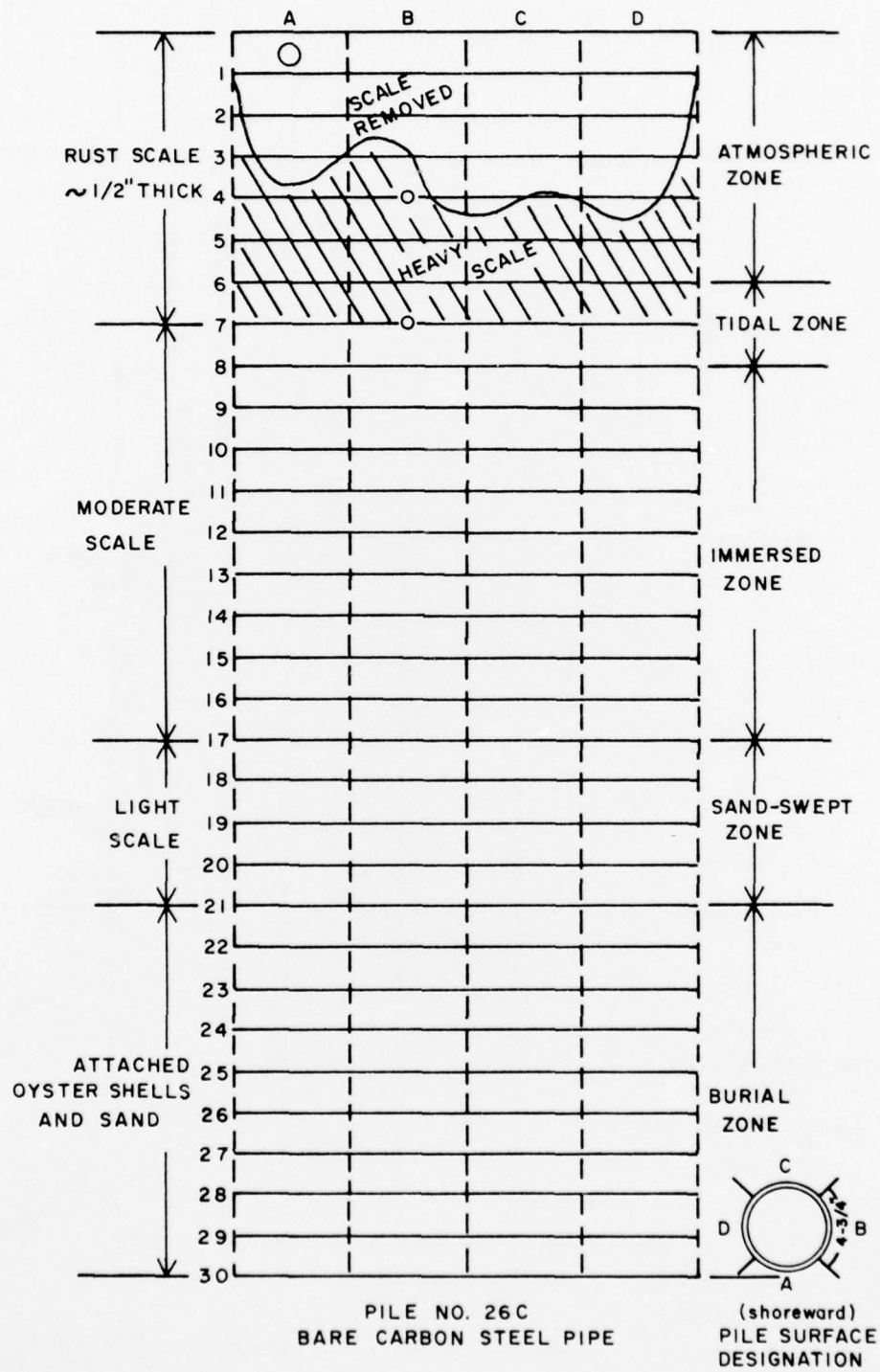

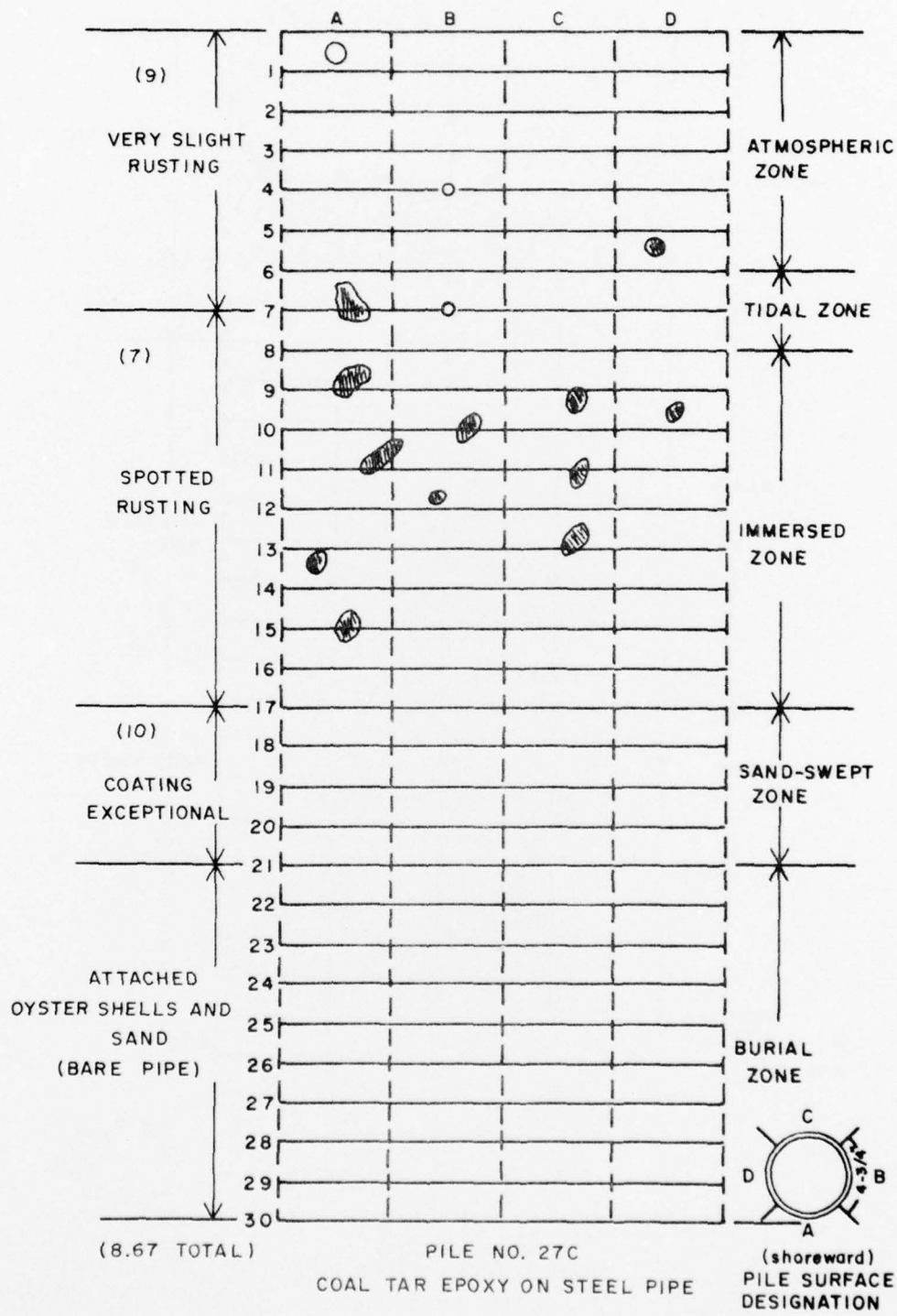

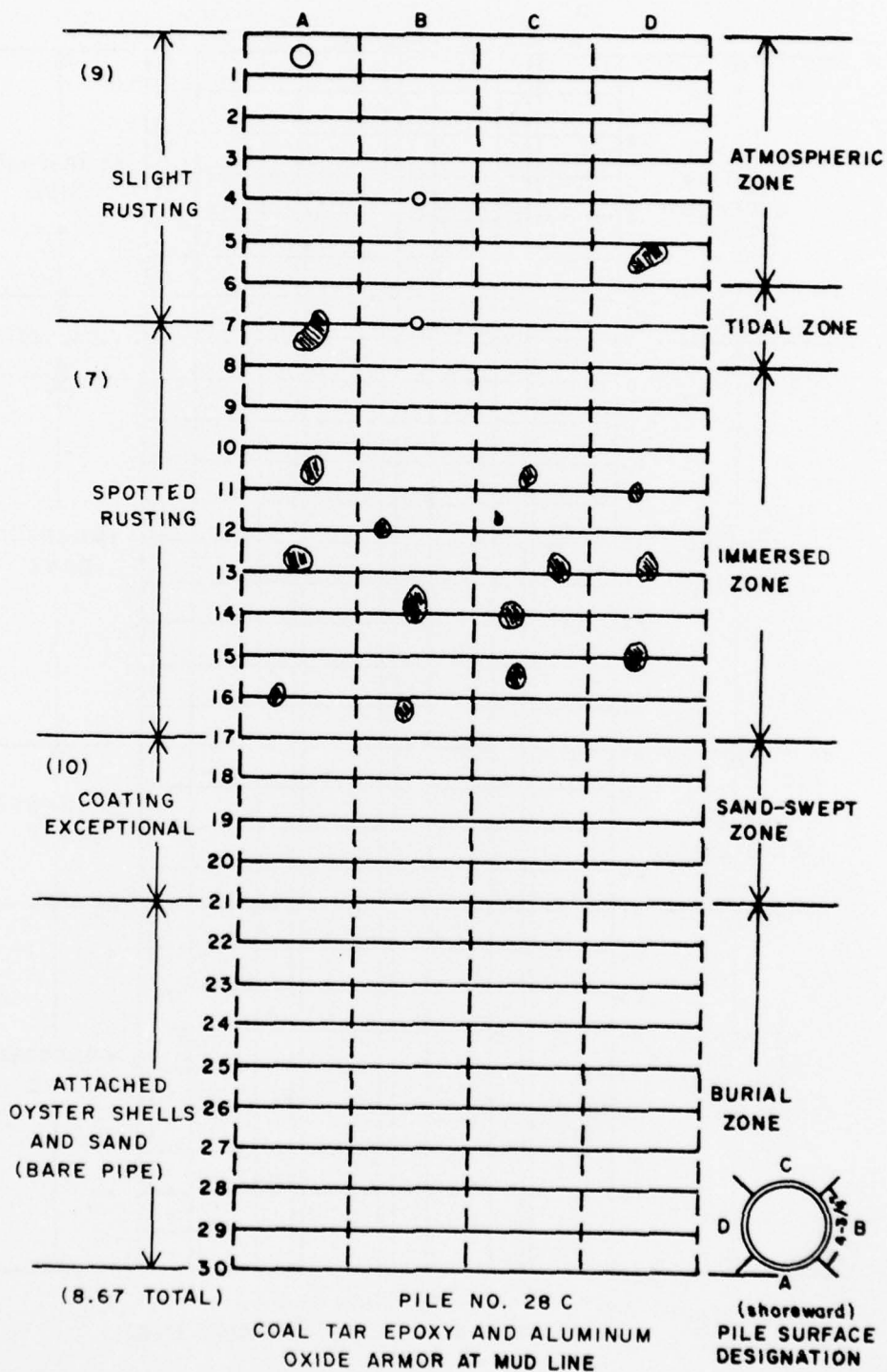

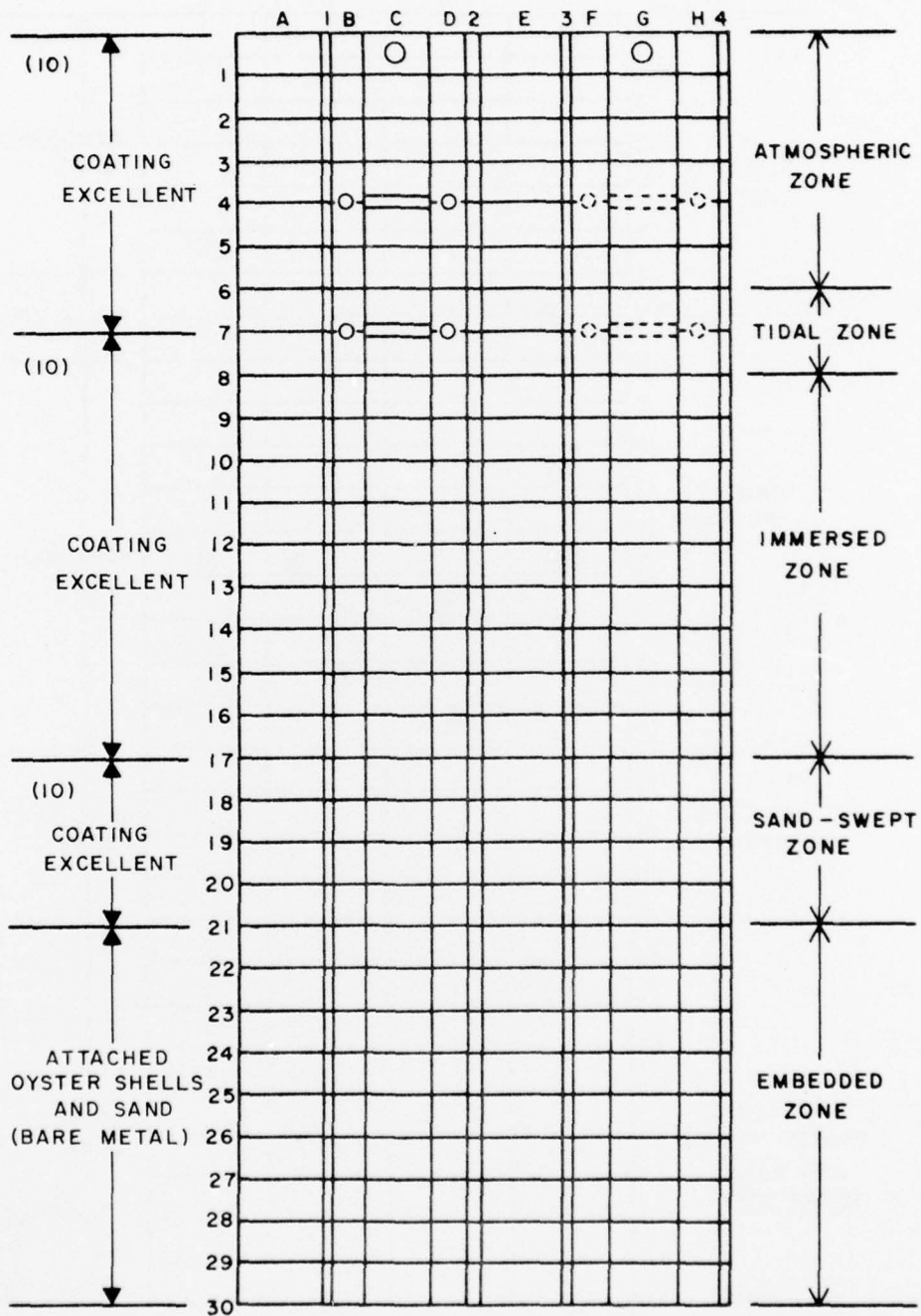

(10.00 TOTAL)

PILE NO. 29 C  
POLYESTER GLASSFLAKE ON CARBON STEEL

## APPENDIX C:

### DERIVATION OF PILE STRUCTURE FACTOR

The design application for the piles tested is unknown. However, if one considers the top of the pile as the point of attachment in the design application, then the top of the pile may be subject to four sets of forces and/or couples in general. The forces and couples on the pile top are termed:

1. Axial force  $P$  running lengthwise along the pile
2. Transverse forces,  $F_x$  and  $F_y$ , in principal moment of inertia axis directions
3. A couple,  $T$ , producing a torsional moment on the pile.

These forces and couples will be transmitted into the pile and result in stresses that must be designed for in any application.

Computation of the stresses within the pile requires use of all the structural section factors considered of importance to this study. It should be noted that the mode of failure of the pile may be other than that related to the pile stress, e.g., axial buckling or torsional buckling. However, the structural section factors needed in these expressions are also contained in all the expressions for stress within the pile resulting from end loading. Examination of the expressions for pile stress is a convenient means of defining the structural section factors. It should also be noted that only factors entering the elastic design of the piles are considered. This simplifies the presentation and provides adequate information considering the coarseness of the analysis based on the minimal adequacy of the data obtained for structural evaluation.

For an axial load  $P$  on a pile, there are two expressions for stress that are important in the pile design application. The first expression is the compressional (or tensile) stress on the section defined by

$$\sigma = \frac{P}{S_A} \quad [\text{Eq C1}]$$

where  $\sigma$  = compression/tension stress  
 $P$  = axial load  
 $S_A$  = cross-sectional area of the pile.

The second expression is the shear stress acting on the surface of the pile from the metal-sediment interface. This is defined by

$$\tau = \frac{P}{C_A} \quad [\text{Eq C2}]$$

where  $\tau$  = pile surface shear stress  
 $P$  = axial load  
 $C_A$  = circumferential area.

In the pile design for axial load (neglecting buckling for the time being),  $S_A$  and  $C_A$  are structural section factors of importance. A decrease in either  $S_A$  or  $C_A$  will affect the design stress.

For the transverse loads on a pile acting along the principal axes of inertia,  $F_x$  and  $F_y$ , a bending moment is created in the pile. The expression for the stress in the pile resulting from application of  $F_x$  and  $F_y$  is

$$\sigma = \frac{M'_x}{I'_x} y + \frac{M'_y}{I'_y} x \quad [\text{Eq C3}]$$

for

$$M'_x = M_x - M_y (I_{xy}/I_y)$$

$$M'_y = M_y - M_x (I_{xy}/I_x)$$

$$I'_x = I_x - I_{xy}(I_{xy}/I_y)$$

$$I'_y = I_y - I_{xy}(I_{xy}/I_x)$$

where  $\sigma$  = bending stress  
 $x$  = distance of point of application from the x-axis (x-axis a centroidal axis)  
 $y$  = distance of point of application from the y-axis (y-axis a centroidal axis)  
 $M_x$  = bending moment about the x-axis from components  $F_x$  and  $F_y$   
 $M_y$  = bending moment about the y-axis from components of  $F_x$  and  $F_y$   
 $I_x$  = moment of inertia of the section about the x centroidal axis  
 $I_{xy}$  = product of inertia about the x, y centroidal axes  
 $'$  denotes corroded section.

This formula is for unsymmetrical bending and is of sufficient generality to define the stress on a section of the pile at point  $x, y$ . The structural section factors of importance here are  $I_x, I_y,$  and  $I_{xy}$ . These factors are also important in lateral buckling of piles.

The last factor of importance in the study is derived from the expression for shear stress on the pile resulting from a couple,  $T$ , on the pile. The shear stress may be written

$$\tau = \frac{T r}{J} \quad [\text{Eq C4}]$$

where  $\tau$  = shear stress from torsion  
 $T$  = couple on section  
 $r$  = section dimension  
 $J$  = polar moment of inertia of the section.

For rectangular sections or sections composed of rectangles,  $J$  is taken as

$$J = \sum_k (1/3) b h^3 \quad [\text{Eq C5}]$$

where  $b$  = long dimension of the rectangle  
 $h$  = short dimension of the rectangle  
 $k$  = index over all rectangles composing the section.

$J$  is also found in design expressions for torsional stability of structural members. The centroid of the section is computed from

$$\bar{x} = \frac{\sum \bar{x}_i A_i}{\sum A_i} \quad [\text{Eq C6}]$$

where  $\bar{x}$  = total section centroid  
 $\bar{x}_i$  = centroid for  $i^{\text{th}}$  rectangle  
 $A_i$  = area of  $i^{\text{th}}$  rectangle.

The moments of inertia about the principal axes are determined from the formulas

$$I_{xx} = \frac{I_x + I_y}{2} + \frac{I_x - I_y}{2} \cos 2\theta - I_{xy} \sin 2\theta \quad [\text{Eq C7}]$$

$$I_{yy} = \frac{I_x + I_y}{2} + \frac{I_x - I_y}{2} \cos 2(2\theta + \phi) - I_{xy} \sin(2\theta + \phi) \quad [\text{Eq C8}]$$

for

$$\tan 2\theta = \frac{2I_{xy}}{I_y - I_x}$$

where  $I_x$ ,  $I_y$ , and  $I_{xy}$  are as defined above.

Because of differences in measured pile cross sections in the embedded (buried) zone, defining each pile's nominal section separately was necessary. This was done by averaging the flange and web thicknesses for the buried section (bottom 9 ft [2.7 m]), which was assumed to corrode at a constant rate of 1.1 mil/yr

(0.03 mm/yr). The corroded section dimensions were obtained similarly by averaging the flange and web thicknesses over the corroded section.

A computer program was developed to provide a convenient means of comparing the pile section configurations. The program takes the four flange and web thickness measurements for each section along a given pile, in addition to a nominal section flange and web thickness, and computes the following quantities:

1. The pile nominal section based on an average of flange and web thickness measured from the portion of the pile in the sediment

2.  $\bar{x}$ ,  $\bar{y}$ ,  $I_x$ ,  $I_y$ ,  $I_{xy}$ ,  $S_A$ ,  $C_A$ ,  $J$ ,  $I_{xx}$ ,  $I_{yy}$  for the nominal pile section and the corroded pile section with or without a hole for each section along the pile length for which measurements were taken

3. The ratio of each of the quantities in 2 of the corroded section to the nominal section and a pile structural factor

4. The mean and standard deviation of all the section properties plus  $-3\sigma$  to  $+3\sigma$  variation of the section properties

5. A gross average flange thickness and web thickness over all measurements made and the ratio of the section properties based on this average to the nominal section properties, the mean and standard deviation of measurements of the gross section, the  $-3\sigma$  to  $+3\sigma$  variation, and a pile structural factor.

Table C1 presents the weighting factors for each of the structural factors. The factors were determined based on the influence of each structural factor on the integrity of the pile.

The pile structural section factor is defined to be a weighted sum of the corroded section properties over a weighted sum of the nominal section properties, that is

$$\text{PSSF} = \frac{w_1 \bar{x} + w_2 \bar{y} + w_3 I_x + w_4 I_y - w_5 |I_{xy}|}{w_1 \bar{x} + w_2 \bar{y} + w_3 I_x + w_4 I_y - w_5 |I_{xy}|} + \frac{w_6 S_A + w_7 C_A + w_8 I_{xx} + w_9 I_{yy} + w_{10} J}{w_6 S_A + w_7 C_A + w_8 I_{xx} + w_9 I_{yy} + w_{10} J} \quad [\text{Eq C9}]$$

**Table C1**  
Structural Properties and Associated Weighting Factors

| Property  | Definition                         | Weighting Factor |
|-----------|------------------------------------|------------------|
| $\bar{X}$ | Centroid of section x              | 0                |
| $\bar{Y}$ | Centroid of section y              | 0                |
| $I_x$     | Moment of inertia about x          | 0.05             |
| $I_y$     | Moment of inertia about y          | 0.05             |
| $I_{xy}$  | Product of inertia about x, y      | -0.05            |
| $S_A$     | Cross-sectional area of pile       | 0.20             |
| $C_A$     | Circumferential area of pile       | 0.05             |
| $J$       | Polar moment of inertia of section | 0.20             |
| $I_{xx}$  | Product of inertia for x           | 0.20             |
| $I_{yy}$  | Product of inertia for y           | 0.20             |

where

PSSF = pile structural section factor

$W_i$  =  $i = 1, 10$  weighting factor  
denotes corroded section

and other variables are as defined above for the corroded and nominal sections.

The pile structural section factor is inadequate to fully assess the pile structural degradation because it does not consider the surface condition of the piles.

The measurements made on either the flanges or web seldom reflect the depth of the corrosive pits or whether either flange or web contains holes. The size and density of pits or irregular surface on any one particular section can be important factors in assessing the degree of structural degradation.

As a result of these observations, a second factor that qualitatively assesses the effect of surface structure on the overall section properties was developed. This second factor, termed the structural surface factor (SSF), is defined as follows:

$$SSF = 1 - k_1 \left(\frac{10-x}{10}\right)^{k_2} \quad [\text{Eq C10}]$$

where SSF = structural surface factor

$k_1$  = magnification factor

$k_2$  = importancy factor

$x$  = surface factor (an integer number from 0 to 10).

For a pile with no surface degradation ( $x = 10$ ), SSF is 1.0. For a pile with severe pitting and structural degradation ( $x = 1$ ), SSF is between 0 and 1.0, depending on the values of  $k_1$  and  $k_2$ . The particular selection of the expression for the SSF with  $k_1$  and  $k_2$  variable provides a degree of flexibility that allows modeling according to the degree of importance attached to the SSF.

The pile structural factor (PSF) is the product of the pile structural section factor and the structural surface factor:

$$PSF = (PSSF) \times (SSF) \quad [\text{Eq C11}]$$

Table C2 shows the PSFs for each pile for three combinations of  $k_1$  and  $k_2$ .

Table C2

## Pile Structure Factors

| Pile No. | PSF*    | Rank* | PSF**   | Rank** | PSF†    | Rank† | Normalized Structure |
|----------|---------|-------|---------|--------|---------|-------|----------------------|
|          |         |       |         |        |         |       | Factor††             |
| 1C       | .77337  | 26    | .78139  | 26     | .79497  | 26    | 77.05                |
| 2C       | .86509  | 23    | .88146  | 23     | .90397  | 23    | 86.92                |
| 3C       | .82063  | 24    | .83287  | 24     | .85168  | 25    | 82.13                |
| 4C       | .94852  | 15    | .97338  | 15     | .99446  | 14    | 95.99                |
| 5C       | .99845  | 5     | .99845  | 5      | .99845  | 11    | 98.48                |
| 6C       | .92651  | 18    | .94716  | 18     | .97208  | 17    | 93.40                |
| 7C       | .97027  | 9     | .99193  | 8      | 1.00095 | 6     | 97.82                |
| 8C       | .91861  | 20    | .93231  | 20     | .95336  | 20    | 91.94                |
| 9C       | .99740  | 6     | .99740  | 6      | .99740  | 12    | 98.35                |
| 10C      | 1.00355 | 3     | 1.00355 | 3      | 1.00355 | 4     | 98.96                |
| 11C      | .90790  | 21    | .93139  | 21     | .94660  | 21    | 91.84                |
| 12C      | .88991  | 22    | .91199  | 22     | .93479  | 22    | 89.93                |
| 13C      | .99612  | 7     | .99612  | 7      | .99612  | 13    | 98.23                |
| 14C      | .99961  | 4     | .99961  | 4      | .99961  | 8     | 98.57                |
| 15C      | .96162  | 14    | .98650  | 13     | 1.00261 | 5     | 97.28                |
| 16C      | .96935  | 10    | .99100  | 9      | 1.00001 | 7     | 97.72                |
| 17C      | .96821  | 12    | .98983  | 11     | .99883  | 10    | 97.61                |
| 18C      | 1.00646 | 2     | 1.00646 | 2      | 1.00646 | 2     | 99.25                |
| 19C      | .93824  | 17    | .95919  | 17     | .96791  | 18    | 94.58                |
| 20C      | .96384  | 13    | .98878  | 12     | 1.00492 | 3     | 97.50                |
| 21C      | .92116  | 19    | .93860  | 19     | .96256  | 19    | 92.56                |
| 22C      | .94298  | 16    | .96769  | 16     | .98864  | 15    | 95.42                |
| 23C      | .81520  | 25    | .83063  | 25     | .85183  | 24    | 81.91                |
| 24C      | .97616  | 8     | .97616  | 14     | .97616  | 16    | 96.26                |
| 25C      | .96890  | 11    | .99054  | 10     | .99954  | 9     | 97.68                |
| 29C      | 1.01409 | 1     | 1.01409 | 1      | 1.01409 | 1     | 100.00               |

\*Refers to  $k_1 = 0.1$  and  $k_2 = 0.5$

\*\*Refers to  $k_1 = 0.1$  and  $k_2 = 1.0$

†Refers to  $k_1 = 0.1$  and  $k_2 = 2.0$

††Refers to calculations made from PSF for  $k_1 = 0.1$  and  $k_2 = 1.0$ .

## CERL DISTRIBUTION

MSM

Director of Facilities Engineering  
APO NY 09827

DARCOM STII-EUR  
APO New York 09710

West Point, NY 10996  
ATTN: Dept of Mechanics  
ATTN: Library

Chief of Engineers  
ATTN: DAEN-ASI-L (2)  
ATTN: DAEN-FEU  
ATTN: DAEN-FESA  
ATTN: DAEN-FEZ-A  
ATTN: DAEN-MCZ-S  
ATTN: DAEN-RDL  
ATTN: DAEN-PMS (6)  
for forwarding to  
National Defense Headquarters  
Director General of Construction  
Ottawa, Ontario KIAOK2  
Canada

Canadian Forces Liaison Officer (4)  
U.S. Army Mobility Equipment  
Research and Development Command  
Ft Belvoir, VA 22060

Airports and Const. Services Dir.  
Technical Information Reference  
Centre  
KAOL, Transport Canada Building  
Place de Ville, Ottawa, Ontario  
Canada, KIAONB

Ft Belvoir, VA 22060  
ATTN: Kingman Bldg, Library

Ft Monroe, VA 23651  
ATTN: ATEN

Ft McPherson, GA 30330  
ATTN: AFEN-FED

USA-WES  
ATTN: Concrete Laboratory  
ATTN: Library

6th USA  
ATTN: AFKC-LG-E

US Army Science & Technology Center  
- Far East Office

US Army Engineer District  
Buffalo

ATTN: Library

Pittsburgh

ATTN: Library

Philadelphia

ATTN: Library

ATTN: Chief, NAPEN-D

Baltimore

ATTN: Chief, Engr Div

Norfolk

ATTN: Chief, NAOEN-D

Wilmington

ATTN: Chief, SAWEN-D

Charleston

ATTN: Chief, Engr Div

Savannah

ATTN: Library

ATTN: Chief, SASAS-L

Jacksonville

ATTN: Library

ATTN: Const. Div

Mobile

ATTN: Chief, SAMEN-C

ATTN: Chief, SAMEN-D

Nashville

ATTN: Library

Memphis

ATTN: Chief, LMED-DM

Vicksburg

ATTN: Chief, Engr Div

Louisville

ATTN: Chief, Engr Div

St Paul

ATTN: Chief, ED-D

St Louis

ATTN: Library

Kansas City

ATTN: Library (2)

Omaha

ATTN: Chief, Engr Div

US Army Engineer District  
New Orleans

ATTN: Library

ATTN: Chief, LMED-DG

Little Rock

ATTN: Chief, Engr Div

Tulsa

ATTN: Library

Albuquerque

ATTN: Library

San Francisco

ATTN: Chief, Engr Div

Sacramento

ATTN: Chief, SPKED-D

Japan

ATTN: Library

Portland

ATTN: Chief, DB-6

Seattle

ATTN: Chief, NPSCO

Walla Walla

ATTN: Library

ATTN: Chief, Engr Div

Alaska

ATTN: Library

ATTN: NPADE-R

US Army Engineer Division

Europe

ATTN: Technical Library

New England

ATTN: Library

ATTN: Chief, NEDED-T

North Atlantic

ATTN: Chief, NADEN-T

South Atlantic

ATTN: Chief, SADEN-TS

ATTN: Library

Huntsville

ATTN: Library (2)

ATTN: Chief, HNOED-CS

ATTN: Chief, HNOED-SR

Lower Mississippi Valley

ATTN: Library

Ohio River

ATTN: Library

ATTN: Chief, Engr Div

North Central

ATTN: Library

Missouri River

ATTN: Library (2)

Southwestern

ATTN: Library

ATTN: Chief, SWDED-TM

Pacific Ocean

ATTN: Chief, Engr Div

North Pacific

ATTN: Chief, Engr Div

Facilities Engineers

Ft Campbell, KY 42223

USAECOM

Ft Monmouth, NY 07703

DFAE, USAIC

Ft Benning, GA 31905

TRADOC

Ft Knox, KY 40121

Ft Sill, OK 73503

Ft Bliss, TX 79916

HQ, 1st Inf Div & Ft Riley

HQ, 5th Inf Div & Ft Polk

HQ, 7th Inf Div & Ft Ord

AF Civil Engr Center/XRL

Tyndall AFB, FL 32401

Naval Air Systems Command

ATTN: Library

WASH DC 20360

Naval Facilities Engr Command

ATTN: Code 04

Alexandria, VA 22332

P. O. Hueneke, CA 93043

ATTN: Library (Code LOBA)

Washington, DC

ATTN: Transportation Research Board

ATTN: Library of Congress (2)

ATTN: Dept of Transportation Library

Defense Documentation Center (12)

Engineering Societies Library

New York, NY 10017