

ADA 038970

Final Report

*AW*  
*NW*

March 1975

**K-BAND IMAGE-REJECT AND K<sub>a</sub>-BAND  
BALANCED MIXERS CONSTRUCTED USING  
PLANAR MILLIMETER-WAVE TECHNIQUES**

By: A. K. GORWARA      U. H. GYSEL      D. R. CHAMBERS

Prepared for:

NAVAL ELECTRONICS LABORATORY CENTER  
271 CATALINA BOULEVARD  
SAN DIEGO, CALIFORNIA 92151

CONTRACT N00123-74-C-1957

DDC  
MAY 2 1977  
C

**DISTRIBUTION STATEMENT A**  
Approved for public release;  
Distribution Unlimited



**STANFORD RESEARCH INSTITUTE**  
Menlo Park, California 94025 · U.S.A.

Copy No: **41**.....

# DISCLAIMER NOTICE

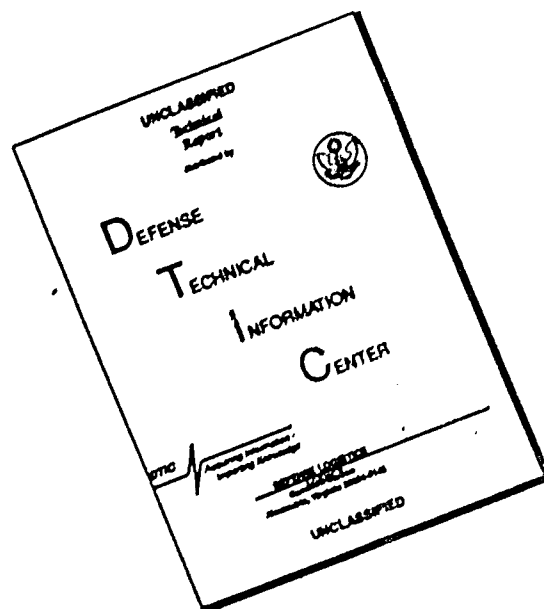

THIS DOCUMENT IS BEST QUALITY AVAILABLE. THE COPY FURNISHED TO DTIC CONTAINED A SIGNIFICANT NUMBER OF PAGES WHICH DO NOT REPRODUCE LEGIBLY.

REPORT DOCUMENTATION PAGE		READ INSTRUCTIONS BEFORE COMPLETING FORM
1. REPORT NUMBER	2. GOVT ACCESSION NO.	3. RECIPIENT'S CATALOG NUMBER
4. TITLE (and Subtitle) K-BAND IMAGE-REJECT AND Ka-BAND BALANCED MIXERS CONSTRUCTED USING PLANAR MILLIMETER-WAVE TECHNIQUES.		5. TYPE OF REPORT & PERIOD COVERED Final Report 13 May 1974 through 30 March 1975
7. AUTHOR(s) Ashok K./Gorwara, Ulrich H./Gysel Donald R./Chambers		6. PERFORMING ORG. REPORT NUMBER SRI Project 3414
9. PERFORMING ORGANIZATION NAME AND ADDRESS Stanford Research Institute Menlo Park, California 94025		8. CONTRACT OR GRANT NUMBER(s) N00123-74-C-1957 <i>new</i>
11. CONTROLLING OFFICE NAME AND ADDRESS Naval Electronics Laboratory Center 271 Catalina Boulevard San Diego, California 92151		10. PROGRAM ELEMENT, PROJECT, TASK AREA & WORK UNIT NUMBERS 13 11 P.
14. MONITORING AGENCY NAME & ADDRESS (if diff. from Controlling Office)		12. REPORT DATE Mar 1975
16. DISTRIBUTION STATEMENT (of this report) <b>DISTRIBUTION STATEMENT A</b> Approved for public release; Distribution Unlimited		13. NO. OF PAGES 128
17. DISTRIBUTION STATEMENT (of the abstract entered in Block 20, if different from report)		15. SECURITY CLASS. (of this report) Unclassified
18. SUPPLEMENTARY NOTES		15a. DECLASSIFICATION/DOWNGRADING SCHEDULE
19. KEY WORDS (Continue on reverse side if necessary and identify by block number)		
Mixers	Couplers and filters	Balanced mixers
Downconverter	Diode detectors	Single balanced mixer
Millimeter-wave techniques	Detectors	Receiver front ends
Planar-circuit techniques	Image-reject mixer	
20. ABSTRACT (Continue on reverse side if necessary and identify by block number)		
<p>An image-reject mixer for K-band (18.0 to 26.5 GHz) and a balanced mixer for Ka-band (26.5 to 40.0 GHz) have been developed using planar microwave integrated-circuit techniques. These mixers have low-noise performance over the entire waveguide bands and successfully demonstrate the first wideband applications of planar MIC techniques at millimeter wavelengths. Further, they established the feasibility of the MIC approach up to 40 GHz and pave the way for similar developments to 80 GHz and beyond. → next page</p>		

332 500

mt

DDDC  
MAY 2 1975  
MILITARY

19. KEY WORDS (Continued)

20 ABSTRACT (Continued)

cont

→ The design, fabrication, and performance of the K-band image-reject mixer and the Ka-band balanced mixer are presented and discussed.

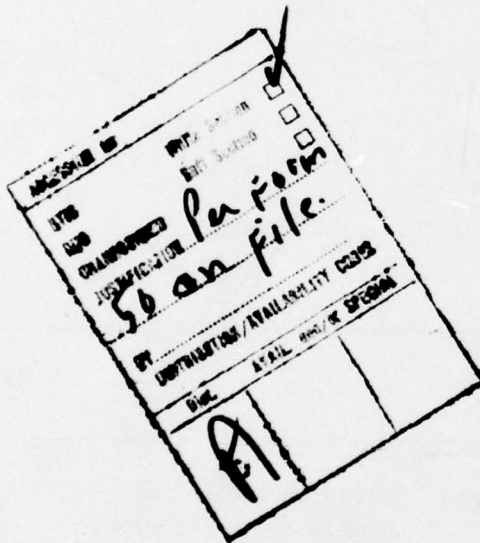

CONTENTS

LIST OF ILLUSTRATIONS . . . . .	v
LIST OF TABLES . . . . .	vii
ACKNOWLEDGMENTS . . . . .	ix
I INTRODUCTION . . . . .	1
A. Summary . . . . .	1
B. Recommendations . . . . .	3
II K-BAND (18.0 to 26.5 GHz), MIC, IMAGE-REJECT MIXER . . . . .	5
A. Background . . . . .	5
B. Design Principles . . . . .	6
C. Measured Performance . . . . .	9
D. Design and Performance of Component Parts . . . . .	15
1. General . . . . .	15
2. K-Band (18.0 to 26.5 GHz), MIC, Single-Balanced Mixer . . . . .	16
3. Diode Selection and Matching Network . . . . .	20
4. K-Band (18.0 to 26.5 GHz), MIC, 3-dB Quadrature Hybrid . . . . .	22
5. Low-Pass Filter . . . . .	24
E. Conclusions . . . . .	24
References . . . . .	26
III Ka-BAND (26.5 to 40 GHz) PLANAR BALANCED MIXER . . . . .	27
A. Background . . . . .	27
B. Design Considerations . . . . .	30
C. Measured Performance . . . . .	35

III	Ka-BAND (26.5 to 40 GHz) PLANAR BALANCED MIXER (Continued)	
	D. Design and Performance of Component Parts . . . . .	43
	1. LO-IF Diplexer . . . . .	43
	2. Waveguide-to-Slotline Transition . . . . .	46
	3. Diode Matching Network Design and Theoretical Conversion Loss . . . . .	47
	E. Conclusions . . . . .	49
	References . . . . .	51

APPENDICES

A	OPERATING INSTRUCTIONS FOR THE K-BAND, MIC, IMAGE-REJECT MIXER, MODEL KIRM-2(2) . . . . .	53
B	FINAL TECHNICAL PERFORMANCE MEASUREMENT COMPARISON FOR THE K-BAND, MIC, IMAGE-REJECT MIXER, MODEL KIRM-2(2) . . . . .	61
C	OPERATING INSTRUCTIONS FOR THE Ka-BAND, BALANCED MIXER, MODEL RBM-1 . . . . .	87
D	FINAL TECHNICAL PERFORMANCE MEASUREMENT COMPARISON FOR THE Ka-BAND BALANCED MIXER, MODEL RBM-1 . . . . .	95

## ILLUSTRATIONS

II-1	K-Band (18.0 to 26.5 GHz), MIC, Image-Reject Mixer, Model KIRM-2(2) . . . . .	6
II-2	Block Diagram of Image-Reject Mixer . . . . .	7
II-3	RF and Bias Circuitry of K-Band (18.0 to 26.5 GHz), MIC, Image-Reject Mixer, Model KIRM-2(2) . . . . .	8
II-4	Noise-Figure Characteristics at 26 GHz for the K-Band (18.0 to 26.5 GHz), Image-Reject Mixer, Model KIRM-2(2) . . . . .	11
II-5	Conversion Loss, Image Rejection, and 2 x 2 Intermodulation Products for the K-Band (18.0 to 26.5 GHz), Image-Reject Mixer, Model KIRM-2(2) . . . . .	12
II-6	Transfer Characteristics for the K-Band (18.0 to 26.5 GHz), MIC, Image-Reject Mixer, Model KIRM-2(2) . . . . .	13
II-7	Return Loss and Isolation Characteristics for the K-Band (18.0 to 26.5 GHz), MIC, Image-Reject Mixer, Model KIRM-2(2) . . . . .	14
II-8	Real and Image IF-Port Return-Loss Characteristics for the K-Band (18.0 to 26.5 GHz), MIC, Image-Reject Mixer, Model KIRM-2(2) . . . . .	16
II-9	Double-sideband Noise-Figure Characteristics at 26 GHz for the K-Band (18.0 to 26.5 GHz), MIC, Balanced Mixer, Model KDMIX-1 . . . . .	18
II-10	Lowest Attainable Noise Figure at 26 GHz for the K-Band (18.0 to 26.5 GHz), MIC, Balanced Mixer, Model KDMIX-1 . . . . .	19
II-11	Conversion Loss for the K-Band (18.0 to 26.5 GHz), MIC, Balanced Mixer, Model KDMIX-1 . . . . .	19
II-12	Return Loss and Isolation Characteristics for the K-Band (18.0 to 26.5 GHz), MIC, Balanced Mixer, Model KDMIX-1 . . . . .	21

II-13	Return Loss Characteristic for Broadband Matching Network for K-Band Mixer Diode, HP 5082-2769 . . . . .	22
II-14	Performance Characteristics for the K-Band (18.0 to 26.5 GHz), MIC, 3-dB, Quadrature Hybrid . . . . .	23
II-15	Low-Pass-Filter Performance Characteristics . . . . .	25
III-1	Schematic of Ka-Band Balanced Mixer Using Balanced and Unbalanced Lines . . . . .	29
III-2	Photograph of Balanced Mixer from 26.5 to 40 GHz Showing the Two Halves of the Housing and the Two Quartz Substrates . . . . .	31
III-3	Detailed View of the Balanced Mixer Circuit for 26.5 to 40 GHz . . . . .	32
III-4	Ka-Band Planar Balanced Mixer . . . . .	33
III-5	Conversion Loss and Noise Figure of Ka-Band Balanced Mixer, Model RBM-1 . . . . .	37
III-6	Return Loss of RF and LO Port of Ka-Band Balanced Mixer, Model RBM-1 . . . . .	38
III-7	LO-to-RF Isolation for Ka-Band Balanced Mixer, Model RBM-1 ( $P_{LO} = +6$ dBm) . . . . .	40
III-8	Noise Figure Versus LO Power for Ka-Band Balanced Mixer, Model RBM-1 . . . . .	41
III-9	High IF Frequency Response of Ka-Band Balanced Mixer, Model RBM-2 . . . . .	42
III-10	Measurement Results of LO-IF Diplexer . . . . .	45
III-11	Equivalent Circuit of Beam-Lead Diode and Matching Network . . . . .	47
A-1	K-Band (18.0 to 26.5 GHz), MIC, Image-Reject Mixer, Model KIRM-2(2) . . . . .	56
A-2	K-Band MIC Image-Reject-Mixer Connector Layout . . . . .	56
C-1	Ka-Band MIC Balanced-Mixer Connector Layout . . . . .	91

TABLES

I-1	Mixer Performance Summary . . . . .	2
II-1	Performance of K-Band, MIC, Image-Reject Mixer, Model KIRM-2(2) . . . . .	10
III-1	Test Results of 26.5-to-40-GHz Balanced Mixer, Model RBM-1 . . . . .	36
A-1	Specifications of K-Band Image-Reject Mixer . . . . .	55
C-1	Specifications of Ka-Band Balanced Mixer . . . . .	89

#### ACKNOWLEDGMENTS

The authors wish to acknowledge the valuable contributions made by other SRI personnel--namely, Joe Hunt, Engineering Associate, who fabricated and assembled the microminiature MIC hardware, and John Watjen, Research Engineer, who assisted in the unique measurements and in evaluating the test results on the K-Band, MIC image-reject mixer. Further, SRI authors deeply appreciate the support and confidence of John Reindel, NELC Technical Monitor, and John Griffin, NELC Program Manager.

## I INTRODUCTION

### A. Summary

The Electromagnetic Techniques Laboratory of Stanford Research Institute has designed, developed, and fabricated a planar K-band (18.0 to 26.5 GHz) low-noise, balanced mixer with a wide IF bandwidth of 10 GHz using advanced microwave-integrated-circuit (MIC) techniques specifically suited for millimeter-wave applications. These mixers successfully demonstrate the first application of planar MIC techniques at millimeter wavelengths to achieve low-noise performance over wide bandwidths. They establish the feasibility of the planar MIC approach up to 40 GHz and pave the way for similar developments to 80 GHz and beyond.

The major goals of the development were to:

- Obtain wideband operation in each mixer covering as a minimum the K- and Ka- waveguide bands, respectively.
- Demonstrate the high-performance capability of planar millimeter-wave circuit techniques for future system applications.
- Establish techniques that are feasible for operation to the 40-to-60-GHz range and above.
- Establish design techniques that can be easily extended to include YIG-tuned filters and local oscillators all on one substrate.
- Obtain a design of minimum size and eliminate bulky waveguide adapters.
- Achieve nominal conversion loss and noise-figure performance for LO power variations of up to 6 dB.
- Provide IF filters designed with 10-GHz bandwidth to extend the potential mixer application capabilities to systems using double conversion.

The primary objectives of the mixer development program were to achieve high performance over wide bandwidths in a small volume with high reliability and with low cost in production. All these objectives were achieved by the application, to the millimeter-wave region, of techniques proven at lower frequencies. This approach assured the successful completion of the development program within a six month period and resulted in mixers that met all the expected performance specifications.

The highlights of the typical performance of the two types of mixers for a LO power level of +3 dBm are listed in Table I-1. Additional details on the performance are contained in Sections II and III.

Table I-1

MIXER PERFORMANCE SUMMARY

Main Test Parameters	K-Band Image-Reject Mixer (18-26.5 GHz)		Ka-Band Balanced Mixer (26-40 GHz)	
	Goal	Achieved	Goal	Achieved
LO port VSWR	2.5:1	1.4:1	2.5:1	2.5:1
RF port VSWR	2.5:1	1.5:1	2.5:1	1.5:1
IF port VSWR	2.0:1	1.25:1	1.5:1	1.25:1
Conversion loss	8.5 dB	8.7 dB	8.0 dB	8.0 dB
Noise figure at 168 MHz IF (IF bandwidth 110 MHz, IF amplifier noise figure 1.5 dB)	10.0 dB	10.2 dB	9.5 dB	9.5 dB
LO to RF isolation	13.0 dB	15.0 dB	25.0 dB	25.0 dB
2 x 2 balance at -20 dB RF power level	40.0 dB	53.0 dB	40.0 dB	45.0 dB
Image rejection	20.0 dB	22.0 dB	Does not apply	Does not apply

B. Conclusions

The K- and Ka-band mixer developments of this program have demonstrated the broadband capabilities of the planar MIC construction at frequencies up to 40 GHz. These MIC techniques can now be considered for application in other broadband systems at mm wavelengths. Some appropriate applications are in IFM (instantaneous frequency measuring) polar discriminators, channelized receiver front ends, superhetrodyne receivers, and other ECM/ESM (electronic counter measures/electronic support measures) applications where wide bandwidth performance is desired with small size and low production cost.

It appears that these planar MIC techniques can be extended further in frequency--first to 60 GHz and possibly to 100 GHz. At this time, the planar MIC technique seems to be the most promising for achieving wide band operation at mm wavelengths. The upper frequency limit will be determined primarily by the precise mechanical dimensions and tolerances obtainable from the available fabrication technique. New design approaches and techniques are necessary to realize circuit components (particularly 3-dB hybrids) with wideband performance at 100 GHz. These new design approaches will require less stringent mechanical tolerances (measured in electrical wavelengths) in order to provide for the development of complete complex planar MIC systems up to 100 GHz.

## II K-BAND (18.0 to 26.5 GHz) MIC, IMAGE-REJECT MIXER

### A. Background

The K-band (18.0 to 26.5 GHz) image-reject mixer was developed for shipboard applications. It is applicable to wideband, low-noise and high-RF-bandwidth receiver systems and features coaxial RF and LO ports for easy integration with YIG-tuned filters and oscillators.

The basic approach used to realize the K-band image-reject mixer was the planar MIC technique. All of the RF circuitry and a major portion of the IF circuitry were constructed on a single sapphire substrate  $0.75 \times 1.50$  inches in size and 0.010 inch in thickness. This approach reduced interconnecting line lengths to a minimum, thereby reducing circuit losses.

Using a single substrate also eliminated connectors and jumpers from the internal circuitry of the image-reject mixer. Subsequently, impedance discontinuities between components were reduced to a minimum so that phase and amplitude matching over a broad band could be more easily achieved. Because each of the component parts on the substrate were processed at the same time, their performances were closely balanced and the overall balance of the image-reject mixer was substantially enhanced.

All of the design performance goals as outlined in the Introduction were achieved for the K-band image-reject mixer Model KIRM-2(2), shown in Figure II-1. In particular, consistent performance was obtained over the entire waveguide bandwidth. The mixer performed as expected from theoretical considerations under conditions of LO power variations of 6 dB.

Section II-B discusses the design principles of the K-band image-reject mixer, and detailed performance characteristics are presented in

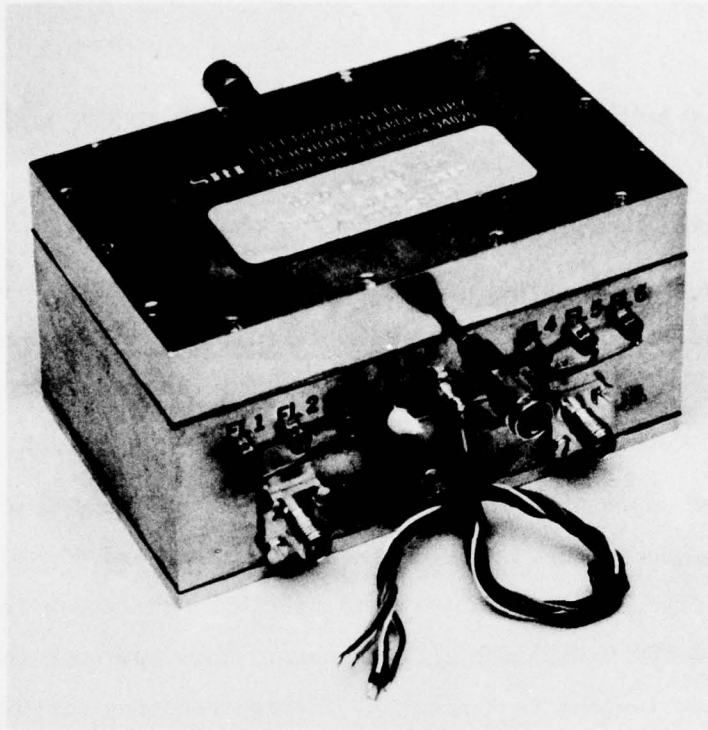

SA-3414-17

FIGURE II-1 K-BAND (18.0 to 26.5 GHz), MIC, IMAGE-REJECT MIXER, MODEL KIRM-2(2)

Section II-C. Section II-D presents performance of the single-balanced-mixer portion of the image-reject mixer for comparison and also includes performance of several of the component parts used in the image-reject mixer. Operating instructions for the image-reject mixer are given in Appendix A. The performance goals for this development and a technical performance comparison are presented in Appendix B.

#### B. Design Principles

The image-reject mixer incorporates a pair of balanced mixers (single-balanced or double-balanced), two RF hybrids, and one IF hybrid as shown in Figure II-2. The RF is fed through a quadrature hybrid while the LO is fed through an in-phase power divider. The IF outputs from each balanced mixer are combined in a quadrature hybrid operating at the IF

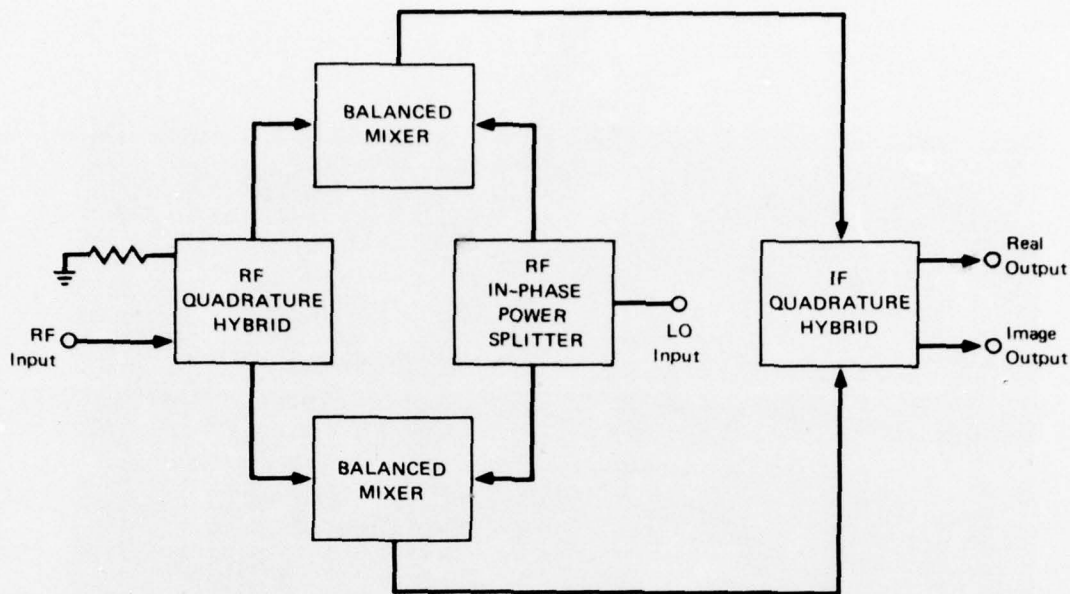

TA652583-94

FIGURE II-2 BLOCK DIAGRAM OF IMAGE-REJECT MIXER

frequency. The response due to the upper sideband appears at one output port of the IF hybrid, while the response due to the lower sideband appears at the other. Therefore, the image response is suppressed without the use of RF bandpass filters preceding the RF port.<sup>1\*</sup> Also, the noise in the image band generated by a microwave preamplifier is suppressed. Either single- or double-balanced mixers may be used in the design of an image-reject mixer, and the respective advantages and disadvantages of each carry over to the image-reject mixer.

Figure II-3 shows the RF, IF, and bias circuitry of the K-band, image-reject mixer, Model KIRM-2(2). The IF quadrature hybrid is contained in the compartment under the substrate and is the only element not visible in the figure. The image-reject mixer shown consists of two single-balanced mixers. RF and LO signals are supplied to each single-balanced mixer through the quadrature hybrid H1, and the in-phase power divider.

\* References are listed at the end of each major section.

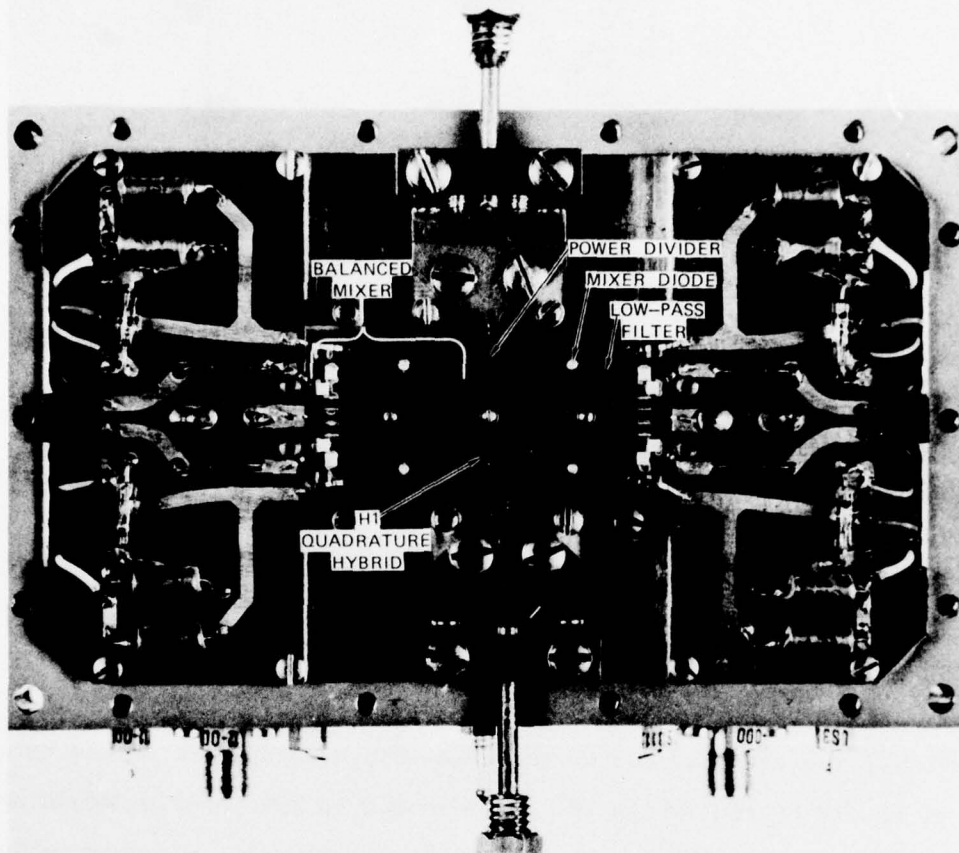

SA-3414-1

FIGURE II-3 RF AND BIAS CIRCUITRY OF K-BAND (18.0 to 26.5 GHz), MIC, IMAGE-REJECT MIXER, MODEL KIRM-2(2)

The RF load resistor for the quadrature hybrid H1 and the balancing resistor for the in-phase power divider are thin-film tantalum nitride resistors fabricated on the substrate during the circuit-delineation process. The two single-balanced mixer portions of the circuit are located on opposite ends of the substrate. The mixer diodes are Schottky-barrier, beam-lead devices (Hewlett-Packard 5082-2769), and are shunt-connected to ground through a conductive-epoxy-filled hole in the sapphire substrate. The IF combining circuits and a portion of the diode-biasing circuits are located at the extreme ends of the substrate. Chip capacitors and chip resistors are used for the dc and IF circuits.

The two PC boards at opposite ends of the sapphire substrate contain the diode bias and protective circuits and provide the bonding pads for ribbon leads connecting to the circuitry on the sapphire substrate. The quadrature hybrid for the IF and the coaxial cables to the IF output ports connect through the back side of the PC board and are not visible in the figure.

### C. Measured Performance

A performance summary of test results obtained for the K-band, image-reject mixer, model KIRM-2(2) is shown in Table II-1.

Details of the noise-figure performance are shown in Figure II-4. From the data in Figure II-4 the diode bias currents were set at 1.0 mA, corresponding to the minimum-noise-figure condition with +3 dBm LO drive. Note also that at 1.0 mA diode current, variations of the LO power from 0 to +10 dBm change the noise figure by only 1.5 dB and by only 0.6 dB for LO power variations from +3 to +10 dBm. Therefore, for the condition in which the LO source may be gradually degrading, as is not unusual at millimeter wavelengths, the KIRM-2(2) mixer is capable of providing noise performance that is only slightly degraded.

The conversion-loss characteristic shown in Figure II-5 illustrates the broadband capability of the KIRM-2(2). The conversion loss is less than 9 dB over 90% of the band and rises to a maximum of 10 dB at the upper bandedge. The image-rejection characteristics and the  $2 \times 2$  intermodulation products are also shown in Figure II-5. The curves labeled Port J1 apply when the LO frequency is greater than the RF frequency, and Port J1 is the output port for the real IF signal. (Port J2 would be the output port for the image signal, in this case.) When the LO frequency is less than the RF frequency, the real signal appears at Port J2 and the curves labeled Port J2 apply. Note that the image rejection is typically

Table II-1

PERFORMANCE OF K-BAND, MIC, IMAGE-REJECT MIXER,  
MODEL KIRM-2(2)

Notes	Parameter	Test Results		
		Max or Min Data		Typical Data
		+3 dBm	+6 dBm	
	Conversion loss, dB	10.0	9.6	8.7
	Image rejection, dB	18	17	22
	LO-to-RF isolation, dB	12	9	15
	LO-to-IF-isolation, dB	36	36	41
	RF VSWR	2.4:1	2.6:1	1.5:1
	LO VSWR	2.0:1	2.4:1	1.4:1
	IF VSWR (168 MHz)	1.4:1	1.4:1	1.25:1
	1-dB compression point, dBm	0	+1	+1.5
1	Common-mode rejection, dB	16	16.4	26
2	2 x 2 suppression, dB	44	45	53
2	4 x 3 suppression, dB	>60	>60	>60
2	3 x 4 suppression, dB	>60	>60	>60
3	2-tone 2nd-order, intermod, dB	-40	-42	N/A
3	2-tone 3rd-order, intermod, dB	-52	<-60	N/A

Mixer Parameters

Frequency: 18.0 to 26.5 GHz  
 Size: 4" x 2.5" x 2.1" excluding connectors  
 Weight: 1 pound  
 Power requirements: +15 Vdc at 2 mA  
 -15 Vdc at 2 mA  
 LO drive range: +3 to +6 dBm

- Notes: (1) Injected RF level = -20 dBm.  
 IF output level measured relative to RF level.
- (2) RF level = -20 dBm.  
 IF output level measured relative to primary IF output.
- (3) RF1 = RF2 = -20 dBm.  
 Data taken at 25 GHz.

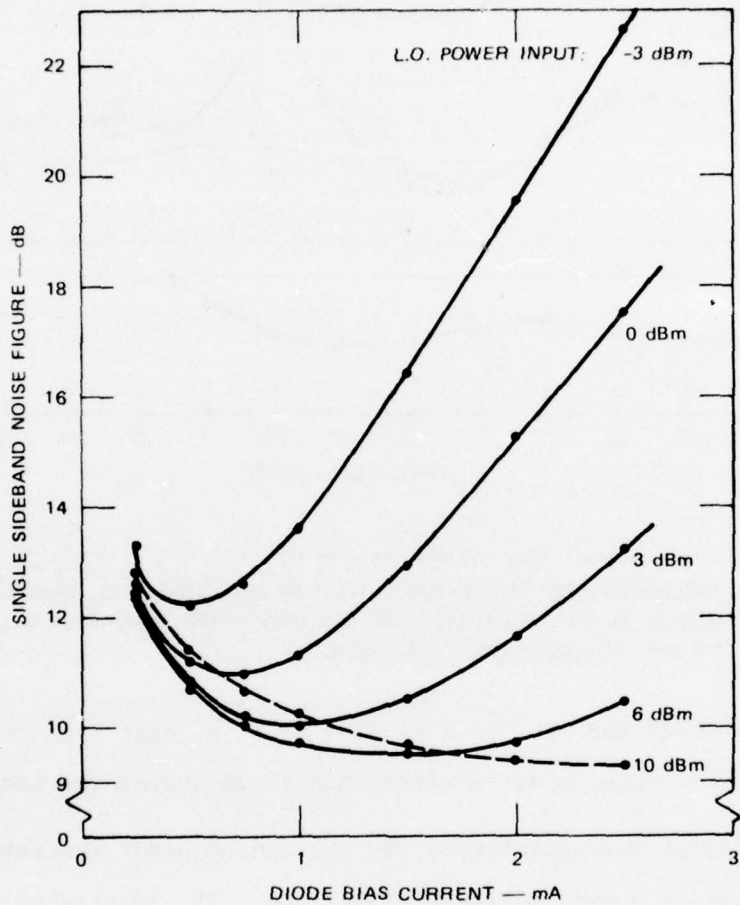

SA-3414-2

FIGURE II-4 NOISE-FIGURE CHARACTERISTICS AT 26 GHz FOR THE K-BAND (18.0 to 26.5 GHz), MIC, IMAGE-REJECT MIXER, MODEL KIRM-2(2)

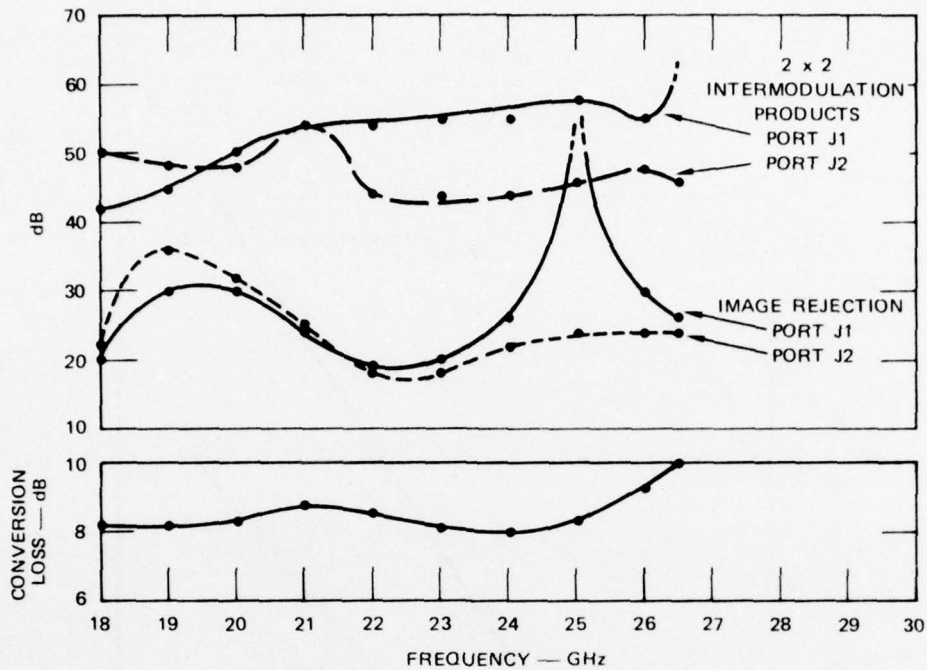

SA-3414-3

FIGURE II-5 CONVERSION LOSS, IMAGE REJECTION, AND 2 X 2 INTERMODULATION PRODUCTS FOR THE K-BAND (18.0 to 26.5 GHz), MIC, IMAGE-REJECT MIXER, MODEL KIRM-2(2). IF frequency = 168 MHz, diode bias currents = 1.0 mA, LO power input = 3.0 dBm.

greater than 20 dB and dips to a minimum of 17 dB near band center. 2 x 2 intermodulation products are greater than 40 dB across the band.

The transfer characteristics and the second-order intermodulation characteristic is shown in Figure II-6. The 1-dB compression point is slightly above 0 dBm and the second-order intermodulation intercept point is +6 dBm. Increasing the LO drive to +10 dBm has only a small effect on the 1-dB compression point, increasing it to about +4 dBm.

The return loss of the LO and RF ports and the LO-to-RF isolation are shown in Figure II-7. The minimum return loss at the RF port is 8 dB, corresponding to a maximum VSWR of 2.3:1. The RF-port return loss over most of the band is greater than 10 dB (VSWR = 1.9:1). The LO port return loss is greater than 10 dB over the entire band. Both the RF and

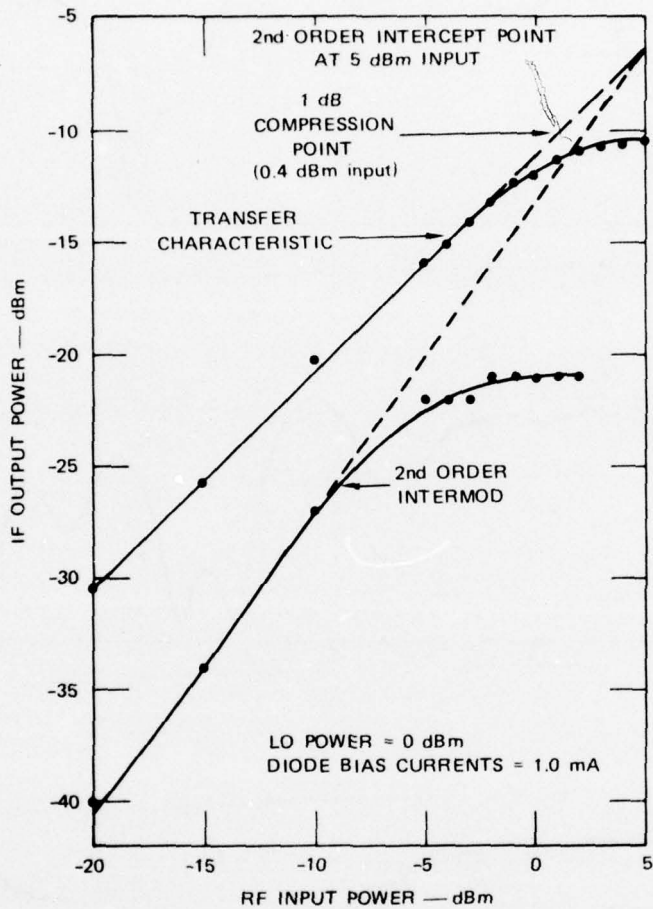

SA-3414-4

FIGURE II-6 TRANSFER CHARACTERISTICS FOR THE K-BAND (18.0 to 26.5 GHz), MIC, IMAGE-REJECT MIXER, MODEL KIRM-2(2). Diode bias currents = 1.0 mA, LO power input = 0 dBm.

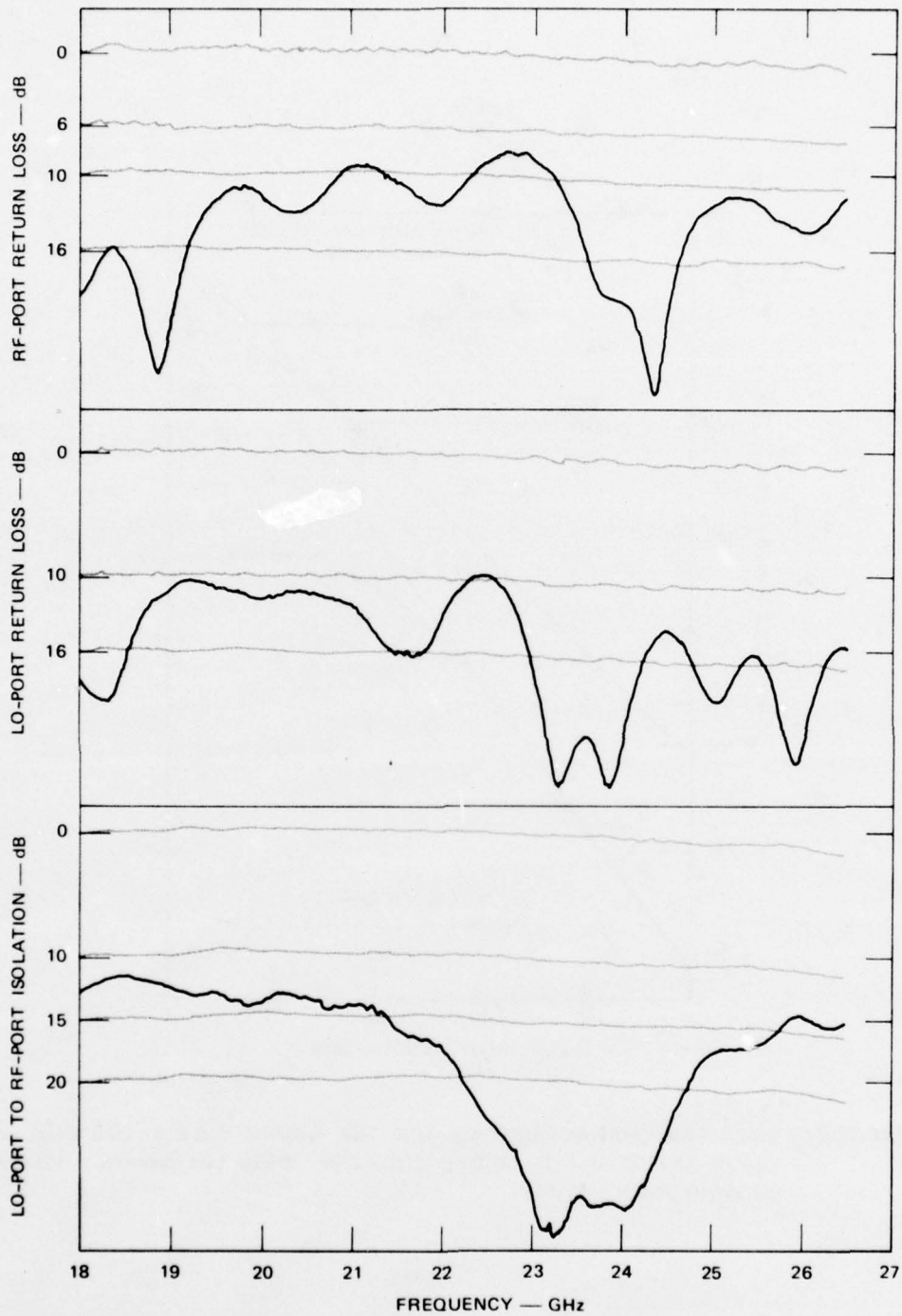

SA-3414-5

FIGURE II-7 RETURN LOSS AND ISOLATION CHARACTERISTICS FOR THE K-BAND (18.0 to 26.5 GHz), MIC, IMAGE-REJECT MIXER, MODEL KIRM-2(2). Diode bias currents = 1.0 mA, LO input power = 3 dBm.

LO ports are fitted with coaxial connectors (Maury Microwave Corp. Type MPC2) suitable for operation at millimeter wavelengths for the purposes of testing (see Figure II-1). (In a system integration, the coaxial cables could mate directly with a YIG-tuned filter and LO, eliminating the connectors.) Assuming that the connector VSWR and the VSWR associated with the coaxial-to-microstrip transition at the substrate are about equal, then the maximum measured VSWR of 2.3:1 corresponds to a maximum VSWR of about 1.5:1 for both. Over most of the band, where the measured VSWR is typically less than 1.9:1, the connector and the transition VSWRs are less than 1.38:1. Therefore, the typical input VSWR to the KIRM-2(2) mixer as seen by a YIG-tuned filter and by a YIG-tuned LO would be on the order of 1.38:1.

The LO-to-RF isolation characteristic shown in Figure II-7 indicates the worst case isolation to be 12 dB at the low-frequency end of the band, which is slightly better than the design goal. The isolation is greater than 14 dB over the remaining 90% of the band and increases to values in excess of 20 dB over a significant fraction of the band.

The return losses of both the image and real IF output ports are identical and are shown in Figure II-8. At the IF frequency of 168 MHz the return loss is 20 dB, corresponding to a VSWR of about 1.2:1.

#### D. Design and Performance of Component Parts

##### 1. General

In order to achieve maximum performance from the image-reject mixer, each component part was first tested separately. In this way, the performance of each component part could be individually optimized, because once the components were assembled into an image-reject mixer, there would be no opportunity for individual testing and the effects of performance deviations would be masked by other components so that interpretation

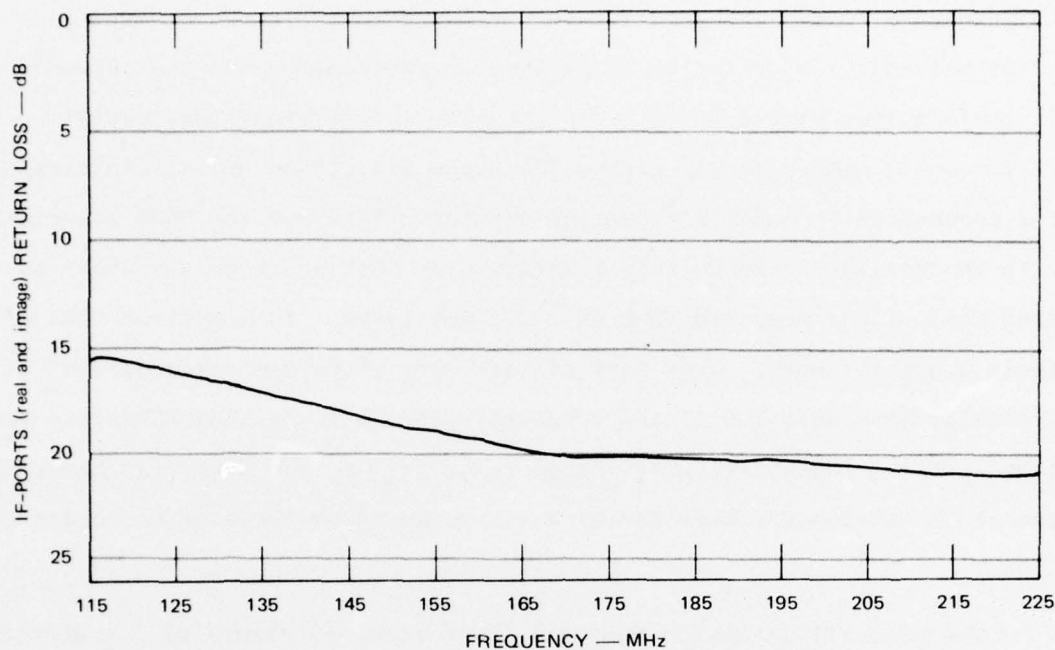

SA-3414-6

FIGURE II-8 REAL AND IMAGE IF-PORT RETURN-LOSS CHARACTERISTICS FOR THE K-BAND (18.0 to 26.5 GHz), MIC, IMAGE-REJECT MIXER, MODEL KIRM-2(2). Diode bias currents = 1.0 mA.

of test results would be extremely difficult. In this subsection, pertinent component parts of the image-reject mixer are discussed and individual performance characteristics are presented. The components are treated in order of descending complexity as follows:

- Balanced Mixer
- Diode selection and matching network
- 3-dB quadrature hybrid
- Low-pass filter.

2. K-Band (18.0 to 26.5 GHz), MIC, Single-Balanced Mixer

A single-balanced mixer was used in the image-reject mixer rather than a double-balanced mixer because it has a lower noise figure and lower

VSWR. In addition, it is somewhat less complex. The single-balanced-mixer portion of the image-reject mixer indicated in Figure II-3 was tested by feeding RF and LO signals into the two arms of the 3-dB quadrature hybrid that are opposite the two arms connecting to the mixer diodes. This was accomplished by constructing the single-balanced mixer on a square substrate approximately one-half the length of the image-reject-mixer substrate so that the input arms to the 3-dB quadrature hybrid were accessible at the substrate edges and could be connected to coaxial input lines through suitable transitions.

The double-sideband (DSB) noise-figure characteristic of the single-balanced mixer is shown in Figure II-9, and corresponds to curves in Figure II-4 for the image-reject mixer where LO power inputs are two times as great as for the single-balanced mixer to account for the extra diodes. For example, the 0-dBm curve in Figure II-9 corresponds to the +3 dBm curve in Figure II-4. The minimum double-sideband noise figure is 7 dB at 0 dBm LO power input to the single-balanced mixer and occurs at a diode bias level slightly greater than 1 mA. For the same LO power input per diode (+3 dBm total to the mixer) and the same bias level of 1 mA, the noise figure of the image-reject mixer is 10 dB from Figure II-4. The noise figure of the image-reject mixer is the single-sideband noise figure because of the image-cancelling properties of the image-reject circuit, and should be 3 dB greater, theoretically, than the 7-dB double sideband noise figure of the single-balanced mixer.

Figure II-10 shows the noise figure obtained as a function of LO power input with the diode bias currents adjusted for minimum noise figure at each value of LO input power. By adjusting the bias currents as shown, the mixer can be used over a wide range of LO powers with very small variation in the noise-figure performance.

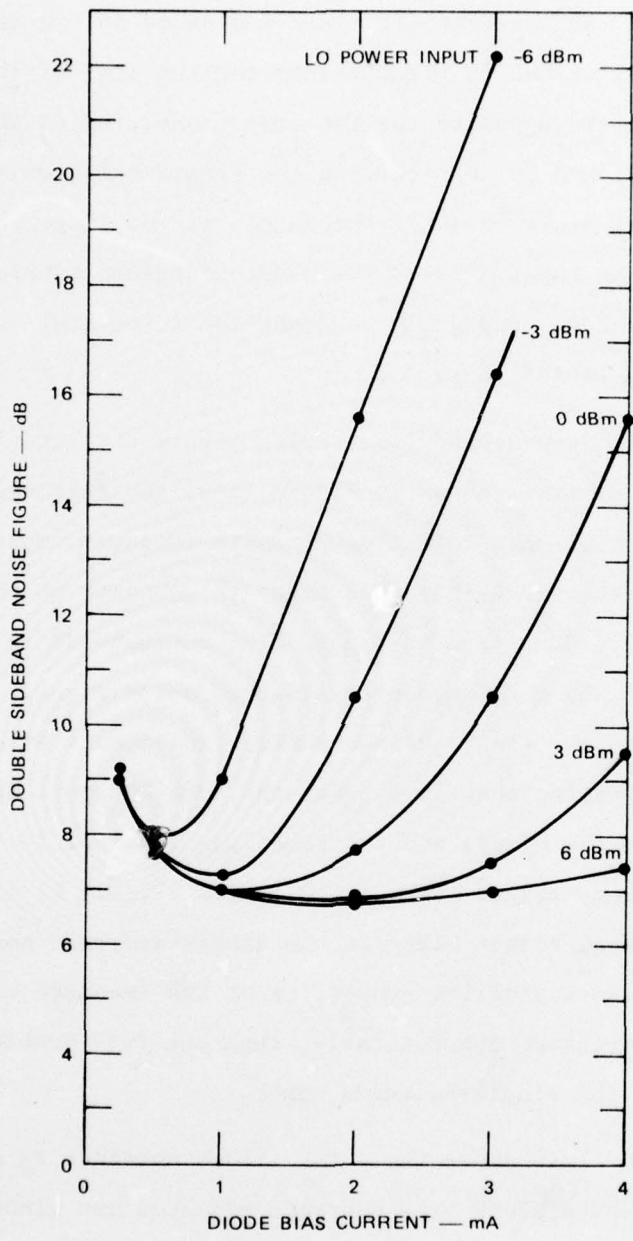

SA-3414-7

FIGURE II-9 NOISE-FIGURE CHARACTERISTICS AT 26 GHz FOR THE K-BAND (18.0 to 26.5 GHz), MIC, BALANCED MIXER, MODEL KDMIX-1

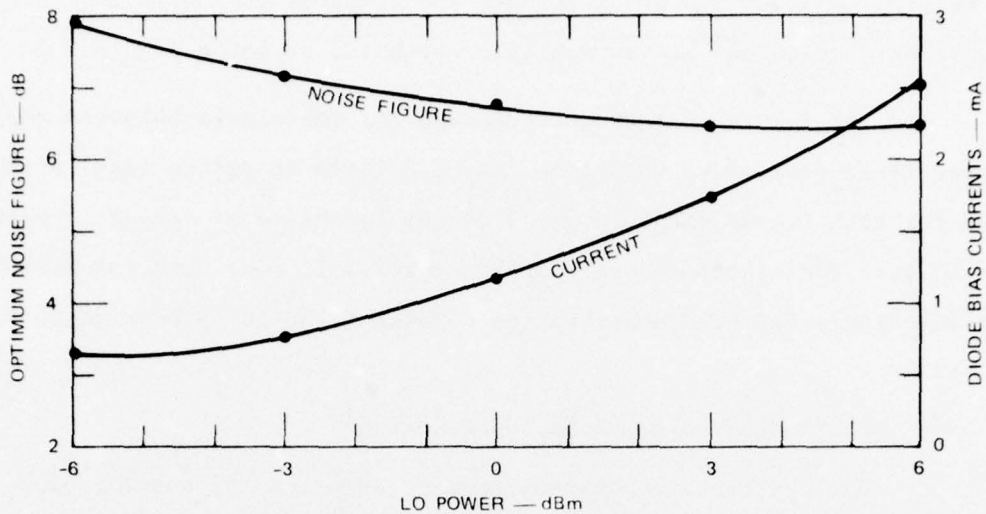

SA-3414-8

FIGURE II-10 LOWEST ATTAINABLE NOISE FIGURE AT 26 GHz FOR THE K-BAND (18.0 to 26.5 GHz), MIC, BALANCED MIXER, MODEL KDMIX-1

The conversion-loss characteristic is shown in Figure II-11. The conversion-loss is typically less than 8 dB over most of the band,

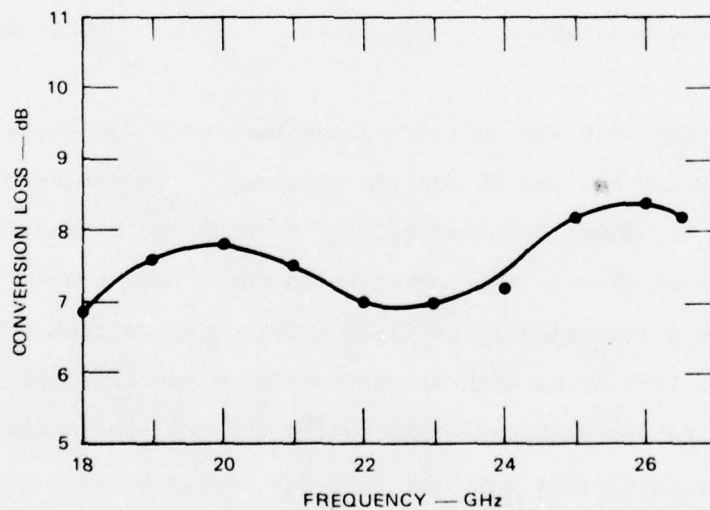

SA-3414-9

FIGURE II-11 CONVERSION LOSS FOR THE K-BAND (18.0 to 26.5 GHz), MIC, BALANCED MIXER, MODEL KDMIX-1. Diode bias currents = 1.0 mA, LO input power = 0 dBm.

increasing to about 8.4 dB at 26 GHz, and compares well with the noise-figure data measured with an amplifier with 1.5 dB noise figure.

The return-loss characteristics for the single-balanced mixer in Figure II-12 indicate a VSWR less than 2.0:1 (10 dB return loss) over the band for both the RF and LO ports with the exception of one point where the LO port VSWR increases to a maximum of 2.3:1. The LO-to-RF isolation for the single-balanced mixer varies between 5 and 10 dB over the band.

### 3. Diode Selection and Matching Network

Hewlett Packard Schottky-barrier beam-lead diodes (HP 5082-2769) were used in the K-band, image-reject mixer. They had the following characteristics

Junction capacitance	0.08 pF
Series resistance	5 ohms
Junction resistance (1 mW LO power)	230 ohms
Package capacitance	0.02 pF
Lead inductance	0.1 nH

The cut-off frequency and self-resonance frequency for these diodes are approximately 400 GHz and 50 GHz, respectively. The diodes were connected electrically in shunt by mounting them between the microstrip line and a grounding post through the substrate to the ground plane. The post was fabricated by ultrasonically drilling a 0.040-inch-diameter hole in the substrate and filling it with silver epoxy. A broadband RF match to the diode impedance was designed by including the beam-lead parasitics as part of a lumped-element matching network. Additional series inductance was obtained by increasing the gap size where the beam-lead diodes were mounted. Additional shunt capacitance was obtained by adding capacitive islands to the microstrip line near the diode.

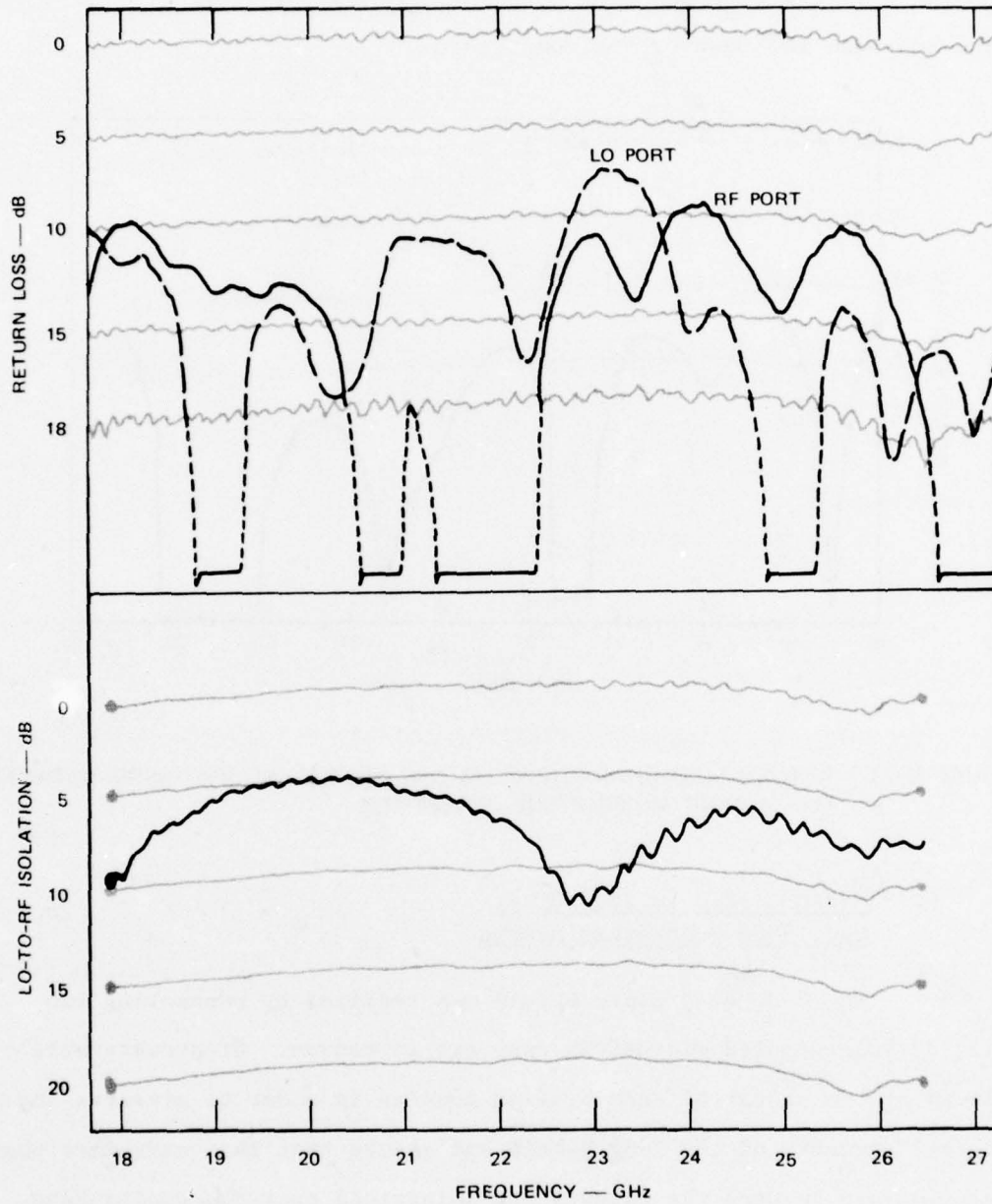

SA-3414-10

FIGURE II-12 RETURN LOSS AND ISOLATION CHARACTERISTICS FOR THE K-BAND (18.0 to 26.5 GHz), MIC, BALANCED MIXER, MODEL KDMIX-1. Diode bias currents = 1.0 mA, LO power input = 0 dBm.

The return loss was more than 12.5 dB over the band, as shown in Figure II-13, corresponding to a maximum VSWR of about 1.6:1. This also includes the VSWR of the connectors.

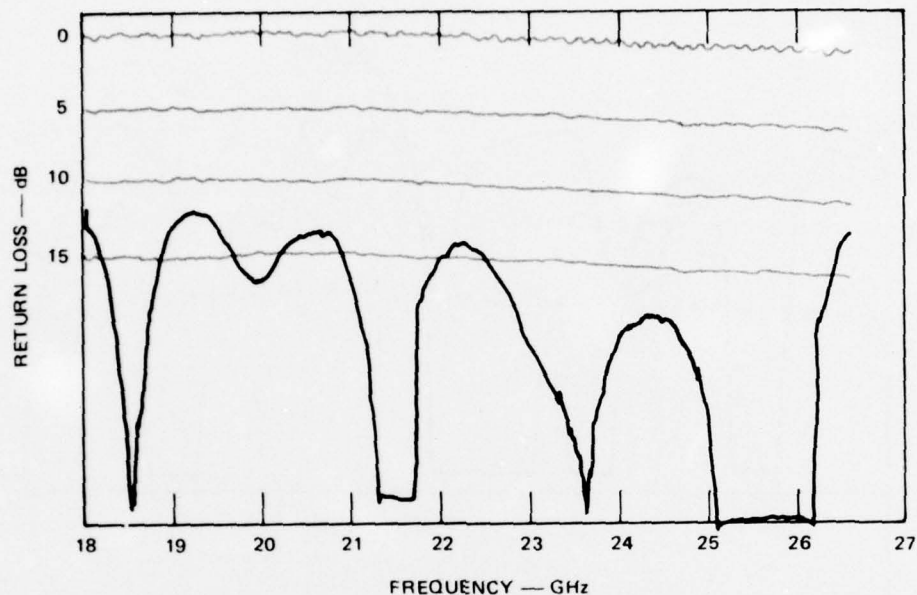

SA-3414-11

FIGURE II-13 RETURN LOSS CHARACTERISTIC FOR BROADBAND MATCHING NETWORK FOR K-BAND MIXER DIODE, HP5082-2769

4. K-Band (18.0 to 26.5 GHz),  
MIC, 3-dB Quadrature Hybrid

The 3-dB quadrature hybrid was realized by connecting two 8.34-dB edge-coupled microstrip couplers in tandem. Crossovers were placed at the center of each 8.34-dB coupler in order to preserve the overall symmetry of the 3-dB hybrid and assure that the quadrature phase relationship between the outputs was maintained over the entire band. Because the coupler is physically very short, the crossovers represent a significant portion of its length and have a significant effect on the performance by introducing discontinuities that increase the ripple response. The effects of the crossovers and also of the discontinuities presented

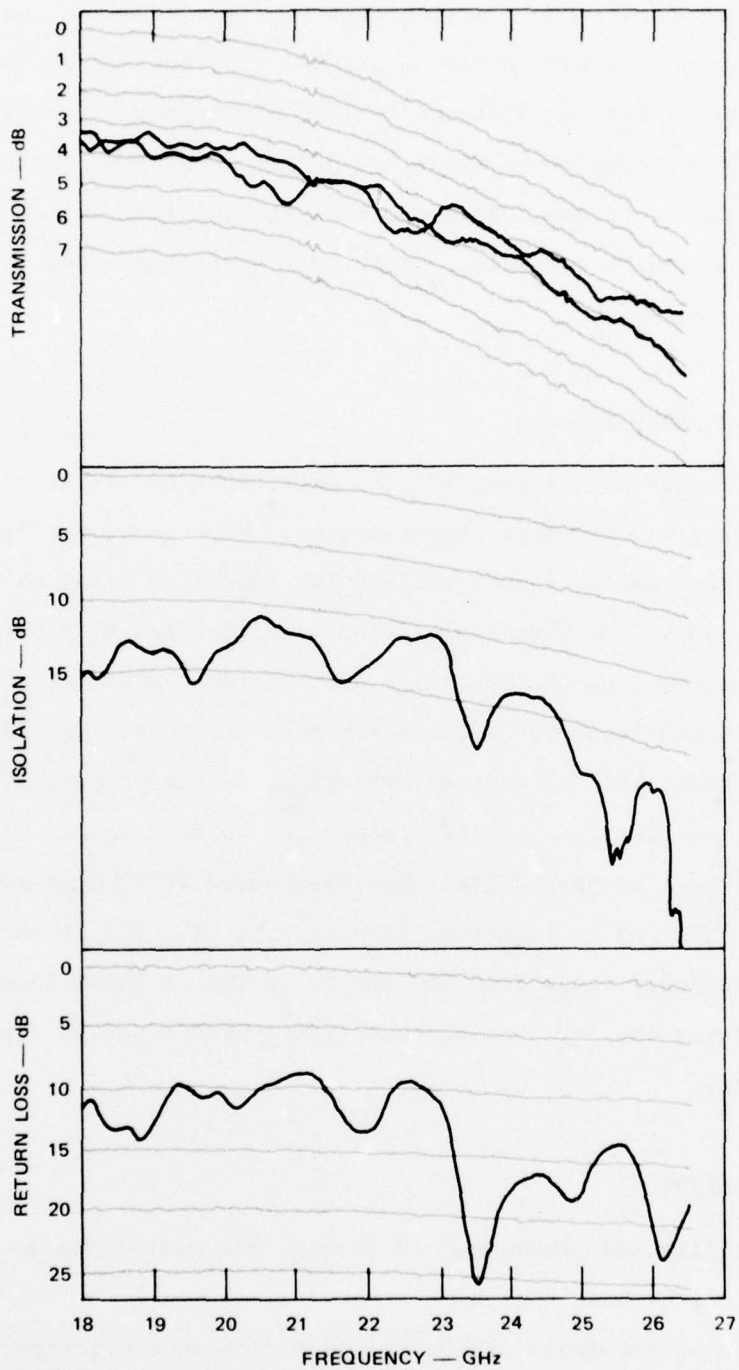

SA-3414-12

FIGURE II-14 PERFORMANCE CHARACTERISTICS FOR THE K-BAND (18.0 to 26.5 GHz), MIC, 3-dB, QUADRATURE HYBRID

to the coupler at its ports during testing are evident in the performance characteristics of Figure II-14. Over the 18.0-to-26.5-GHz band, the coupling-characteristic imbalance is  $\pm 0.7$  dB maximum. The dissipation loss through the coupler is about 0.8 dB for each path. This loss also includes losses introduced by connectors and transitions used to test the hybrid, and would be somewhat less for the hybrid imbedded in the image-reject-mixer circuitry.

#### 5. Low-Pass Filter

The low-pass filter for the extraction of the IF signal was designed using a semilumped approximation. High-impedance lines were used to realize series inductors, and low-impedance lines to realize shunt capacitors. A seven-pole filter was realized by fabricating the capacitor sections on the substrate and bonding 0.001-inch-diameter gold wire between the capacitor islands for the inductors. The IF frequency of the mixer was 168 MHz and was determined by the IF hybrid, but the low-pass filter was designed for IF frequencies up to X band. Measured performance of the low-pass filter when terminated in 50 ohms gave a VSWR of 1.05 at 168 MHz and an insertion loss of 0.10 dB. The filter performance over the frequency range from 300 MHz to 18 GHz is shown in Figure II-15 and illustrates the low-pass characteristic with a cutoff frequency of about 11 GHz.

#### E. Conclusions

The utility and advantages of planar, MIC techniques applied at millimeter wavelengths have been demonstrated successfully by the K-band image-reject-mixer development. The wideband performance obtained is comparable to that of lower-frequency MIC mixers and derives directly from the use of planer techniques and beam-lead diodes with very high cutoff frequencies. By use of the MIC medium, it was possible to avoid the restrictive

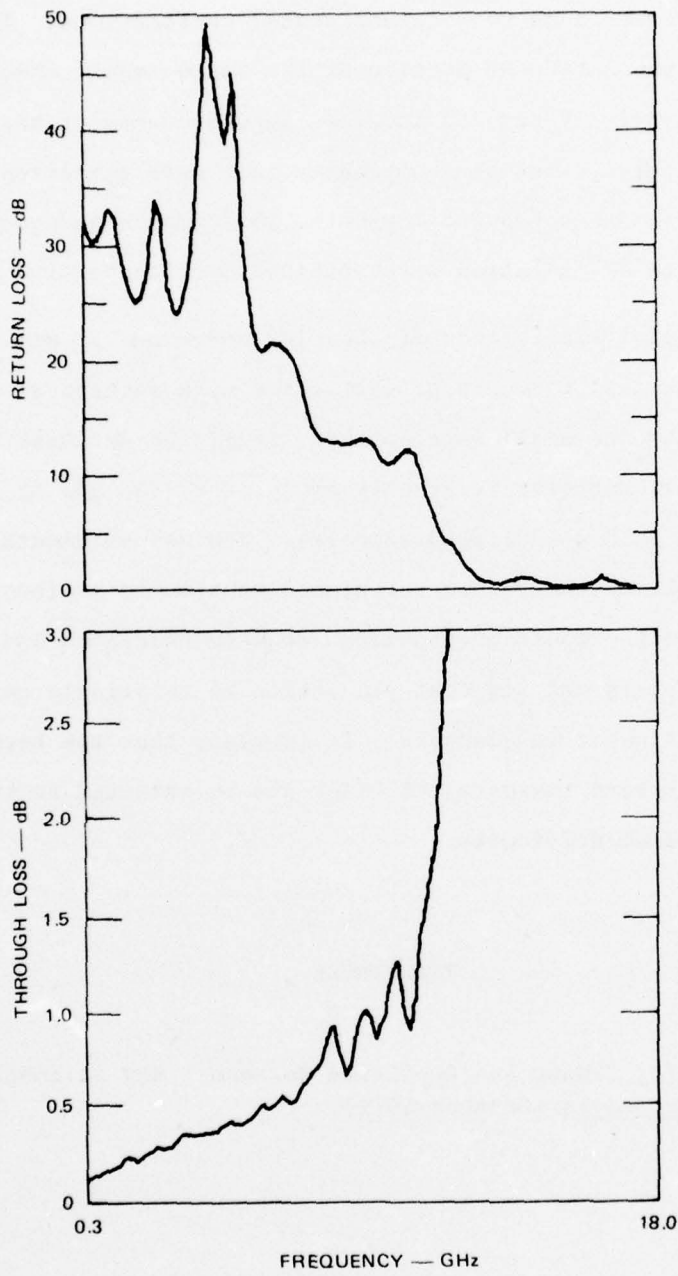

SA-3414-13

FIGURE II-15 LOW PASS FILTER PERFORMANCE CHARACTERISTICS. The 3-dB loss point is at 11.4 GHz.

bandwidth limitations associated with waveguide circuits and to open up the millimeter-wave bands to wideband system realizations. In addition, fabrication of the entire RF portion of the image-reject mixer on a single substrate substantially reduced internal impedance mismatches and resulted in an inherent balance between components that were subjected to identical processing steps. As a result, low-noise performance and good image rejection and LO-to-RF isolation were obtained over the entire K band.

The successful application of the MIC technique at millimeter wavelengths requires that circuits be fabricated with mechanical precision commensurate with the small wavelengths. Precision delineation of the thin-film circuit patterns is greatly enhanced by the use of smooth substrate material such as polished sapphire. The use of smooth substrate materials and photolithographic techniques routine to semiconductor integrated-circuit production provides adequate precision and repeatability to assure high yield and low-cost production of relatively complex MIC circuits at millimeter wavelengths. It is clear that the techniques used to produce the K-band image-reject mixer can be extended to 40 and possibly 60 GHz with minimum difficulty.

#### REFERENCES

1. A. K. Gorwara, "Phase and Amplitude Balance: Key to Image Rejection Mixers," Microwaves (October 1972).

### III Ka-BAND (26.5 to 40 GHz) PLANAR BALANCED MIXER

#### A. Background

Waveguide single-ended and balanced mixers for millimeter-wave frequencies have been available for many years. The instantaneous RF bandwidth of these mixers was limited to between 10% and 20%. Wider bandwidths in waveguide are difficult to achieve. Therefore, a new planar approach was taken that circumvented most of the difficulties of a waveguide design and offered all other advantages of an integrated-circuit design, such as small size, low cost, high reliability, and reproducibility. Two major obstacles that limit the bandwidth of waveguide mixers will be touched upon briefly. For many years, chip diodes mounted in a so-called Sharpless waveguide wafer<sup>1</sup> were the only diodes suitable for millimeter-wave frequencies. These diodes were limited in bandwidth because of the parasitic reactances of the chip itself and those of the wafer mount. More recently, GaAs Schottky-barrier diodes with very high cutoff frequencies (1000 GHz and higher) and low junction capacitances have become available. Even more important, GaAs diodes are now on the market in the form of beam-lead devices, which make microwave integrated circuits (MIC) at millimeter-wave frequencies practical. Because the MIC transmission-line geometries such as microstrip or stripline are smaller than waveguide geometries, and the electromagnetic fields are confined to smaller areas, interconnections with small semiconductor diodes are possible with greatly reduced parasitic reactances.

For wideband applications, single-ended mixers are normally insufficient because they lack local-oscillator (LO) noise suppression and low spurious-response density. Therefore, balanced or double-balanced

mixers have to be used. Balanced mixers require either a  $90^\circ$  or  $180^\circ$  hybrid to combine the LO signal and RF signal. Waveguide hybrids were ruled out because of limited bandwidth (short-slot coupler, branch-line coupler, or magic Tee) or because of excessive coupling imbalances (multi-hole coupler). In addition, all waveguide couplers are quite large in size, and two separate transitions to a circuit medium convenient to mount the two diodes would be required. On the other hand, stripline or microstrip wideband quadrature hybrids from 26.5 to 40 GHz are very difficult to realize. The microstrip design developed for the 18-to-26.5-GHz image-reject mixer probably represents the uppermost limit of that particular design. Branch-line couplers covering the complete Ka-band are feasible, but their performance is not very appealing. Most promising at the time of this writing appears to be a hybrid branch-line coupler in microstrip.<sup>2</sup> This design combines microstrip and slotline to achieve a wideband quadrature hybrid with an easily achievable geometry. It is also important to note the differences between a mixer using a  $90^\circ$  hybrid and one using a  $180^\circ$  hybrid. The  $90^\circ$  hybrid generally has good LO and RF port VSWRs, but suffers from a low LO-to-RF isolation. Opposed to that, a  $180^\circ$  hybrid-coupled mixer has good LO-to-RF isolation but has normally poorer LO and RF port VSWRs. If LO-to-RF isolation is an important factor, the  $180^\circ$  hybrid is the proper choice.

Because none of the above-mentioned hybrids offered performances satisfying all the requirements for a wideband Ka-band mixer, a design based on forming a  $180^\circ$  hybrid junction by joining two orthogonal transmission lines was selected. The basic principle of this design is shown in Figure III-1. The RF input is a balanced-line system (e.g., waveguide, two-wire line, or slot line). The unbalanced input (e.g., coaxial line, stripline, or coplanar waveguide) carries the LO signal. Two diodes appearing in series and with equal polarity across the RF port and in parallel with opposite polarity complete the hybrid junction. With the

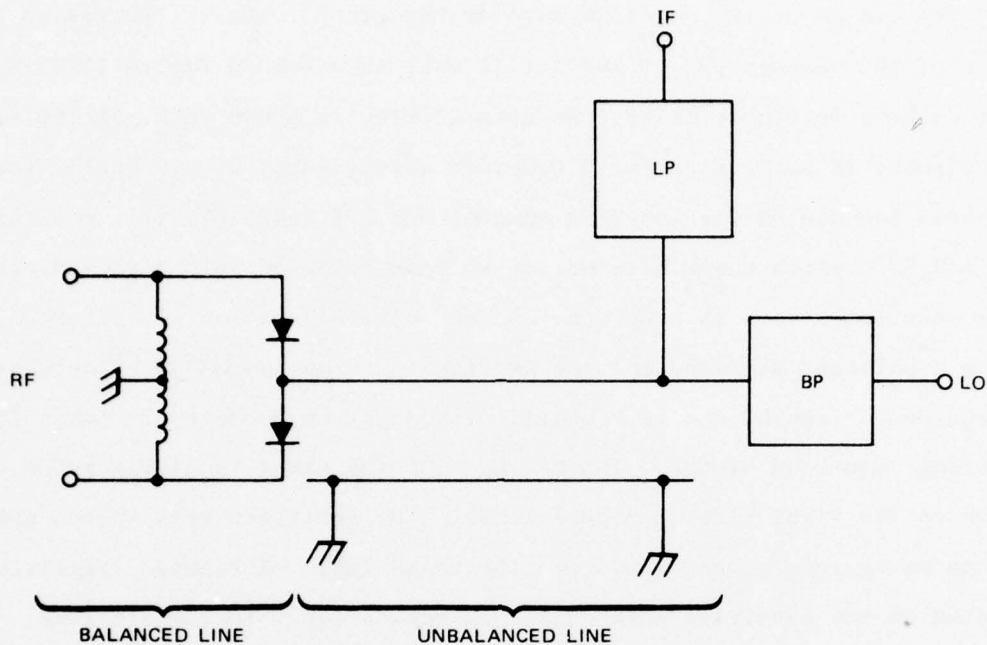

TA-652583-76

FIGURE III-1 SCHEMATIC OF Ka-BAND BALANCED MIXER USING BALANCED AND UNBALANCED LINES

diodes so connected, the IF signal appears on the unbalanced side. Therefore, a diplexer consisting of a low-pass filter (LP) and a bandpass filter (BP) is necessary to separate the IF and LO signals. This hybrid junction is essentially equivalent to a waveguide T with the unbalanced and the balanced ports corresponding to the H and the E arms. The remaining two ports of the waveguide T correspond to the ports to which the diodes are connected. By nature of the geometrical symmetry of the junction, this hybrid has perfect isolation between the RF and the LO ports. In practice, the isolation is limited only by geometrical asymmetries and an imbalance of the diodes. The following section presents details of the practical application of this mixer schematic to the Ka-band mixer.

## B. Design Considerations

The design of the novel 26.5-to-40-GHz mixer is best illustrated by means of the photographs of the actual unit as given in Figure III-2 and particularly in Figure III-3. An outside view is shown in Figure III-4. The circuit is printed on two 0.010-inch quartz substrates. Quartz was selected because of its low loss tangent and its low dielectric constant ( $\epsilon_r = 3.78$ ), which means a reduction in loss compared with higher dielectric substrates such as sapphire. A  $180^\circ$  hybrid junction was selected, using a balanced slotline for the RF signal and an unbalanced coplanar waveguide for the LO and IF signals. The junction geometry is ideal for mounting beam-lead diodes. The RF input of the mixer is in waveguide, shown on the right side in Figure III-3. The substrate sits in the center of the waveguide, perpendicular to the broad wall. A tapered transition printed on the substrate matches the waveguide input to the slotline, which has a characteristic impedance of 100 ohms. Only on the waveguide side, the taper is interrupted by a single step, nominally  $\lambda/4$  away from the edge of the substrate. This step compensates the abrupt discontinuity caused by the emergence of the quartz substrate in the waveguide. Like all major components of the mixer, the taper was evaluated initially in a model experiment at C-band. Design details and results of the component development will be treated separately in Section III-D.

The input line for the LO is a coaxial semirigid cable.\* This allows easy interconnection with a YIG-tuned oscillator, which is usually constructed with coaxial transmission lines. Visible on the left side of Figure III-3 is the transition from the semirigid cable to a suspended substrate. The center conductor of this line is printed on the quartz substrate, with the outer conductor formed by a 0.080-by-0.080-inch channel in the housing. A three-section bandpass filter formed by half-wave,

---

\*The coaxial connector used is the MPC2, male, from Maury Microwave, Cucamonga, California, which provides mode-free operation up to 40 GHz. Transitions from MPC2 to waveguide are available from Maury Microwave.

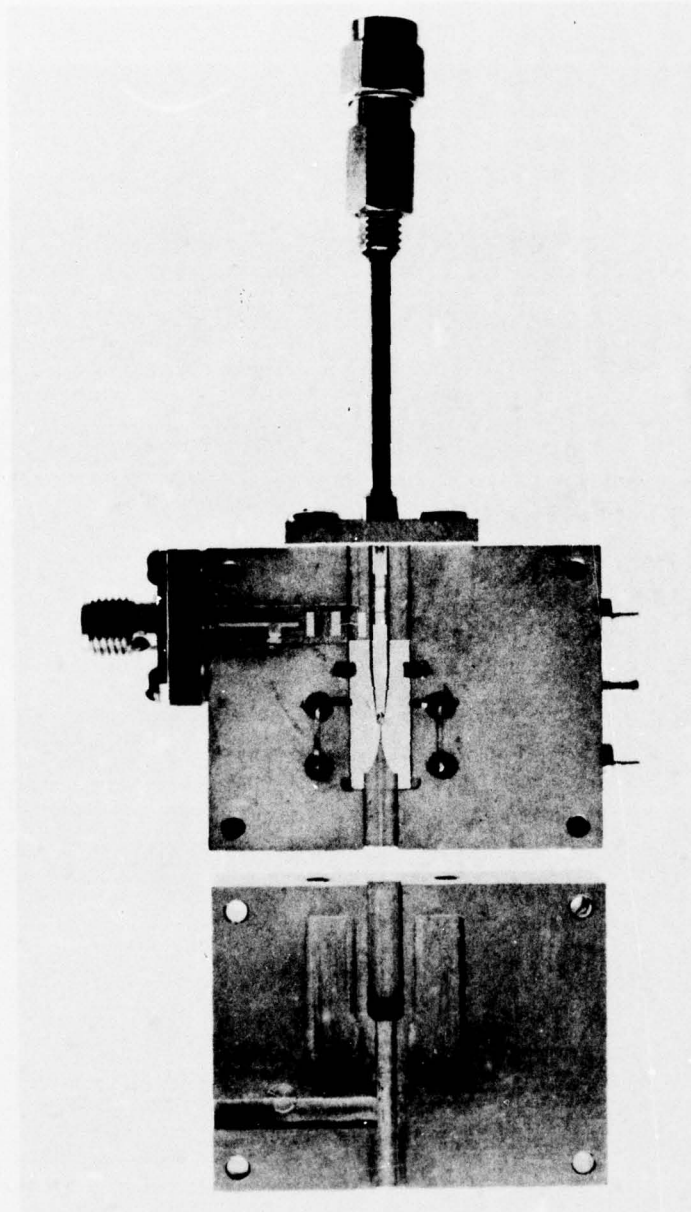

TA-652583-234

FIGURE III-2 PHOTOGRAPH OF BALANCED MIXER FROM 26.5 TO 40 GHz SHOWING THE TWO HALVES OF THE HOUSING AND THE TWO QUARTZ SUBSTRATES

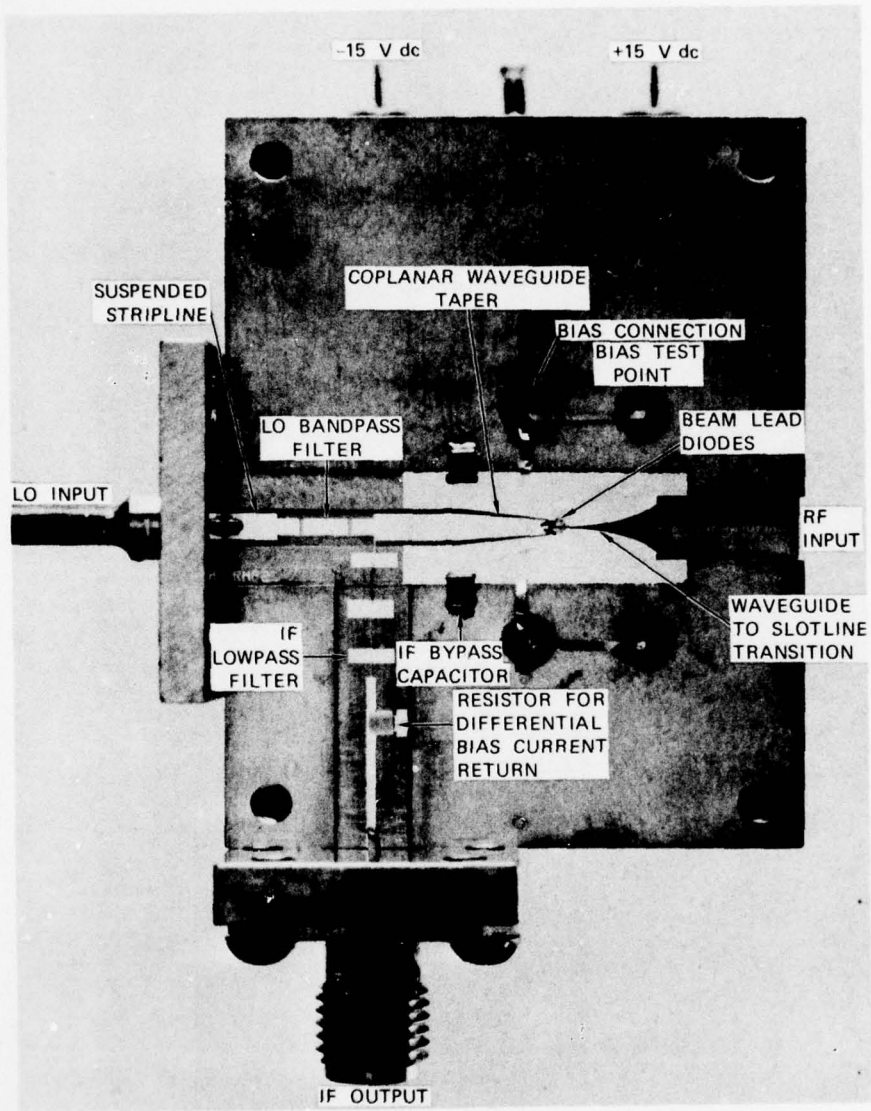

TA-652583-233

FIGURE III-3 DETAILED VIEW OF THE BALANCED MIXER CIRCUIT FOR 26.5 TO 40 GHz

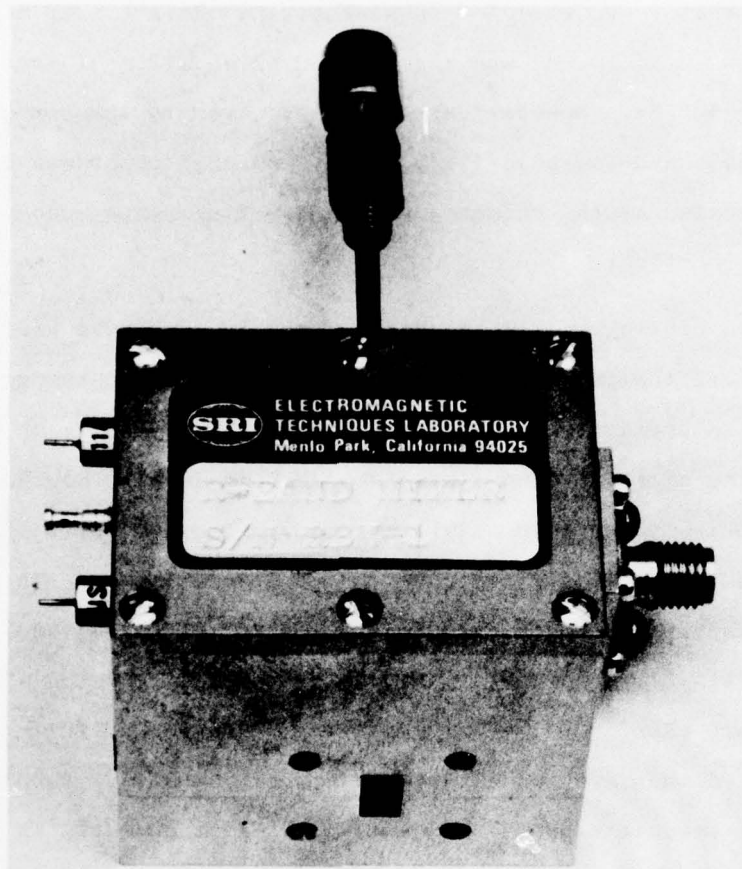

SA-3414-14

FIGURE III-4 Ka-BAND PLANAR BALANCED MIXER

parallel-coupled resonators located alternately on the top and the bottom side of the suspended substrate passes the LO signal, but stops the IF signal. The passband insertion loss of this filter is less than 1 dB. Stop-band insertion loss is better than 21 dB at 10 GHz and 39 dB at 2 GHz. The LO bandpass filter is followed by a section of straight 50-ohm suspended substrate stripline and a tapered section that is more precisely referred to as coplanar waveguide because the channel dimensions do not change in the tapered section. The taper maintains the 50-ohm impedance level. A pair of matched diodes is mounted at the junction of the slotline and the coplanar waveguide.

Extraction of the IF signal occurs by means of a semilumped low-pass filter that is constructed in microstrip. This filter has a nominal passband from dc to 10 GHz and a stop-band attenuation of more than 50 dB from 26.5 to 40 GHz. Special care has been given to the common junction of the bandpass and low-pass filter. The residual reactance of both filters presented at the common junction was taken into account in the design of each filter.

Separate biasing of the two diodes in this mixer was made possible by dc-isolating the large, printed gold areas that form the ground conductor for the coplanar waveguide and the slotline taper. An RF short to the housing of these conductors is accomplished with 0.0005-inch mylar insulators between the gold metallization and the top cover of the mixer. The insulated areas in the top cover are a quarter wavelength wide at mid-band. Together with the cavities on both sides of the waveguide channel (see Figure III-2), an effective RF choke system is formed. Two 1000-pF capacitors are mounted between the substrate and ground for the IF ground return. The diodes are current-biased from a dc voltage supply through resistors of several kilohms. To allow different currents in the two diodes, a 5.1-kilohm resistor is connected to ground on the IF output side to provide a path for the difference in the two diode currents to ground. This resistor has a negligible influence on the performance of the mixer.

The most critical elements of the mixer are the diodes. They determine to a high degree the RF bandwidth, the conversion loss, and the noise figure that are achievable with a given configuration. For millimeter-wave applications, Schottky-barrier diodes with an extremely high cutoff frequency,  $f_c$ , low junction capacitance,  $C_j$ , and low series inductance,  $L_s$ , are required. Beam-lead diodes\* in GaAs with  $C_j = 0.05$  pF have been used in the current Ka-band mixer. The low parasitic reactances of the

---

\* AEI Semiconductors, Lincoln, England.

diodes and the particular mixer design technique, which permits mounting of the diodes with essentially no additional parasitic reactances because matched transmission lines lead directly up to the diode junctions, enable a wideband match of the mixer diodes at all ports. A small sapphire chip across the slotline was used as the only tuning element. In a production unit, however, this chip could be replaced by a printed interdigital capacitor. A good match of the diodes is important, because mismatch losses at the RF and IF port add directly to the noise figure. Excessive mismatch at the LO port reduces the pump power supplied to the diodes and has a detrimental effect on the noise figure and the dynamic range of the mixer. Details about the diode selection and the design of the matching network are presented in Section III-D.

### C. Measured Performance

A final version of the 26.5-to-40-GHz mixer was subjected to numerous tests. A summary of the test results is presented in Table III-1.

Some of the most important results are shown in more detail in the following figures. Conversion-loss data are presented in Figure III-5 for +3 and +6 dBm. Also shown are the noise figures at 39 GHz. A mechanically tuned Gunn oscillator was used for the noise-figure measurements. The increasing difference in conversion loss above 36 GHz between the two LO power levels shown is due to increasing loss in the LO path, which leads to a less-than-sufficient LO drive level at the fixed bias current of 1.5 mA. Figure III-6 shows the return loss for the RF and LO port. The RF-port measurement is made at +0 dBm and 1.5-mA bias current (no LO). It demonstrates the excellent match that was achieved over the full band (10-dB return loss corresponds to a VSWR of 2:1). On the LO side, the return loss is over most of the band below 6 dB (3:1 VSWR). The real part of the LO impedance of one diode is approximately 60 ohms. Two diodes appear in parallel at the LO port, resulting in a 30-ohm

Table III-1

## TEST RESULTS OF 26.5-TO-40-GHz BALANCED MIXER, MODEL RBM-1

Parameter	Test Conditions*	Value
Conversion loss	$P_{LO} = +3$ dBm	8 dB typical 9.5 dB max
	$P_{LO} = +6$ dBm	7.6 dB typical 8.2 dB max
Noise figure	1.3 dB IF amplifier noise figure $P_{LO} = +6$ dBm $f_{RF} = 39$ GHz	9.1 dB
RF-port VSWR		$\leq 1.9:1$
LO-port VSWR		$\leq 3.4:1$
IF-port VSWR	$f_{IF} = 0.1$ to 2 GHz	$\leq 1.33:1$
LO-to-RF isolation		25 dB typical $\geq 17$ dB
LO AM noise suppression		22 dB typical
Spurious-response suppression:		
Single tone		$\geq 39$ dB
2 x 2	$P_{RF} = -20$ dBm	$\geq 60$ dB
4 x 3		$\geq 60$ dB
3 x 4		
Input 1-dB compression point	$f_{RF} = 36$ GHz	-5 dBm
Input 3rd-order-intermodulation intercept point	$f_{RF} = 36$ GHz	+17 dBm

\*  $P_{LO} = +3$  dBm and  $I_{BIAS} = 1.5$  mA, unless otherwise noted.

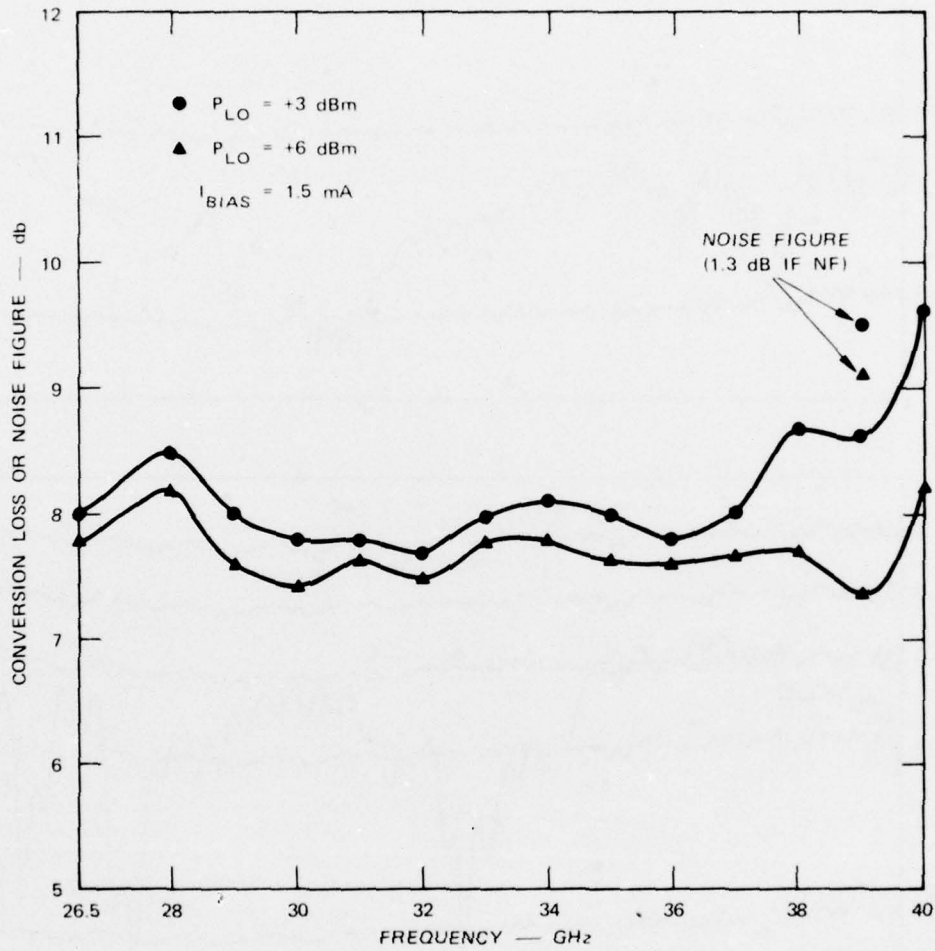

TA-652583-214

FIGURE III-5 CONVERSION LOSS AND NOISE FIGURE OF Ka-BAND BALANCED MIXER, MODEL RBM-1

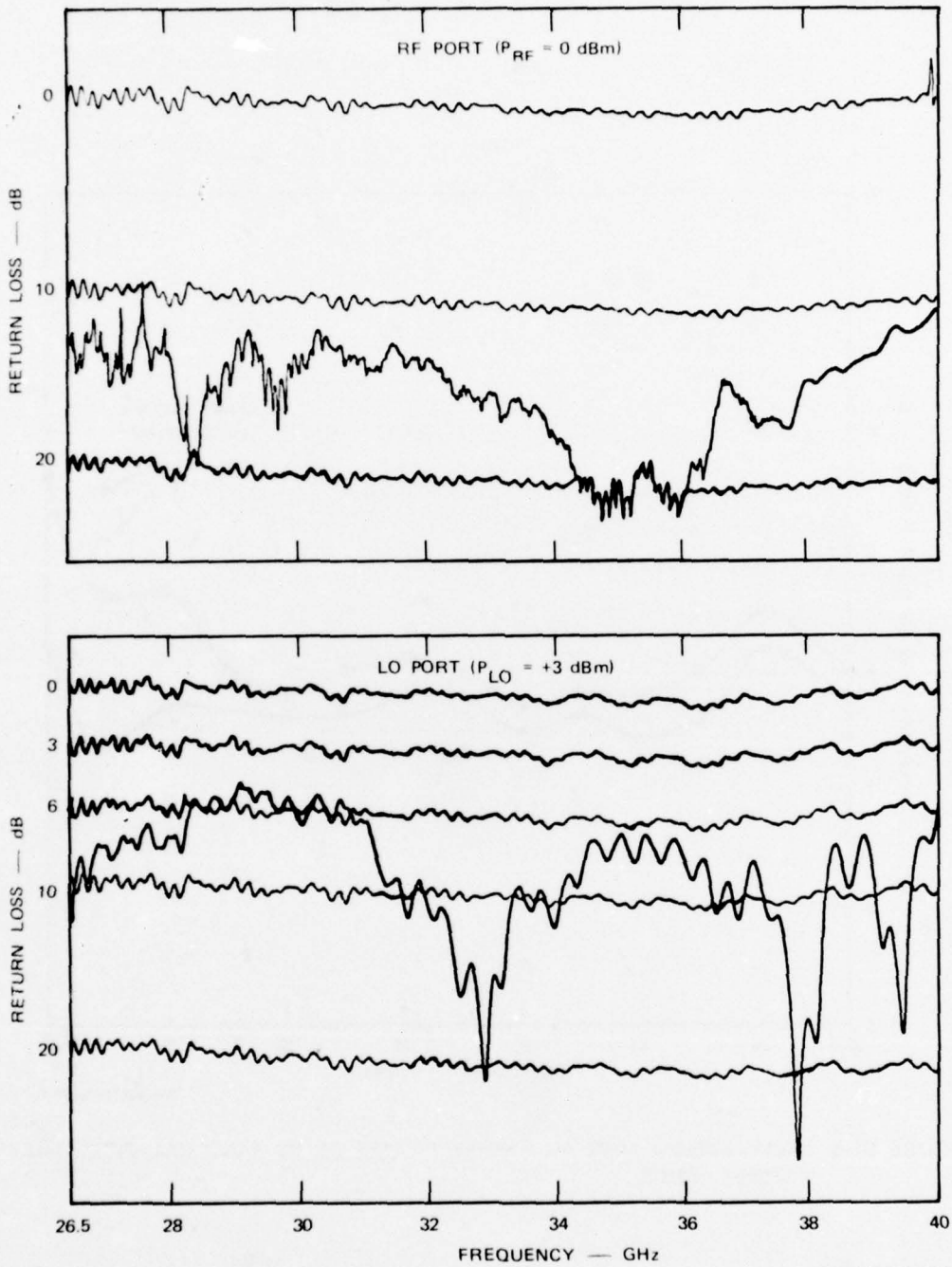

TA-652583-215

FIGURE III-6 RETURN LOSS OF RF AND LO PORT OF Ka-BAND BALANCED MIXER, MODEL RBM-1

termination for the LO transmission line of nominally 50 ohms. The measured VSWR is above the 1.67:1 theoretical level because of the matching network that is optimized for the RF side and not for the LO side, as well as interaction with reflections of the bandpass filter and the transitions. A LO-port VSWR of 3:1 is fully satisfactory for low-noise operation of a balanced mixer at 2-mW incident power level. As Barber<sup>3</sup> pointed out, a pump source that is either significantly higher or lower in impedance than the diode impedance actually slightly improves the conversion loss. The separation of RF and LO port would theoretically permit independent matching of the RF and LO port. However, coplanar waveguide impedances below 50 ohms on a quartz substrate are impossible to obtain because the gaps are too narrow.

The inherent frequency-independent decoupling between the LO and RF port is evidenced by the good LO-to-RF isolation as shown in Figure III-6, and the good LO AM suppression. Actually, the isolation presented in Figure III-7 is not the optimum achievable. Most of the remaining imbalance is caused by the sapphire chip in the diode area. It is difficult to mount the chip in a perfectly symmetrical location. Without the chip, the isolation can easily be adjusted for better than 25 dB by regulating the two diode currents.

Figure III-8 shows the noise-figure dependence at 39 GHz with LO power and as a function of bias current. These test data demonstrate that under proper biasing conditions, a flat noise figure can be maintained with more than 10 dB of LO power variation. This can be obtained at a minor overall sacrifice in noise figure. The high-IF frequency response of the mixer is shown in Figure III-9. Also plotted is the attenuation slope of the IF filter, which indicates that the increase in conversion loss with IF frequency is solely due to the IF filter. For

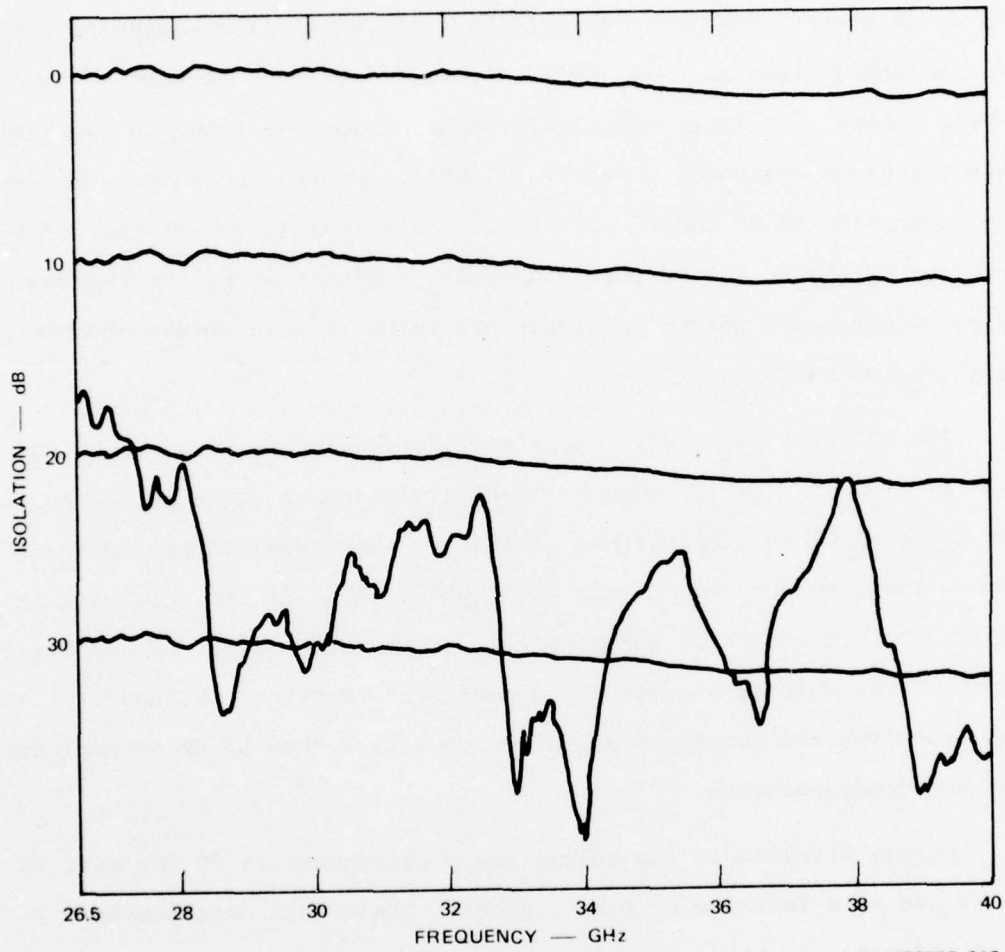

TA-652583-216

FIGURE III-7 LO-TO-RF ISOLATION FOR Ka-BAND BALANCED MIXER, MODEL RBM-1  
 ( $P_{LO} = +6$  dBm)

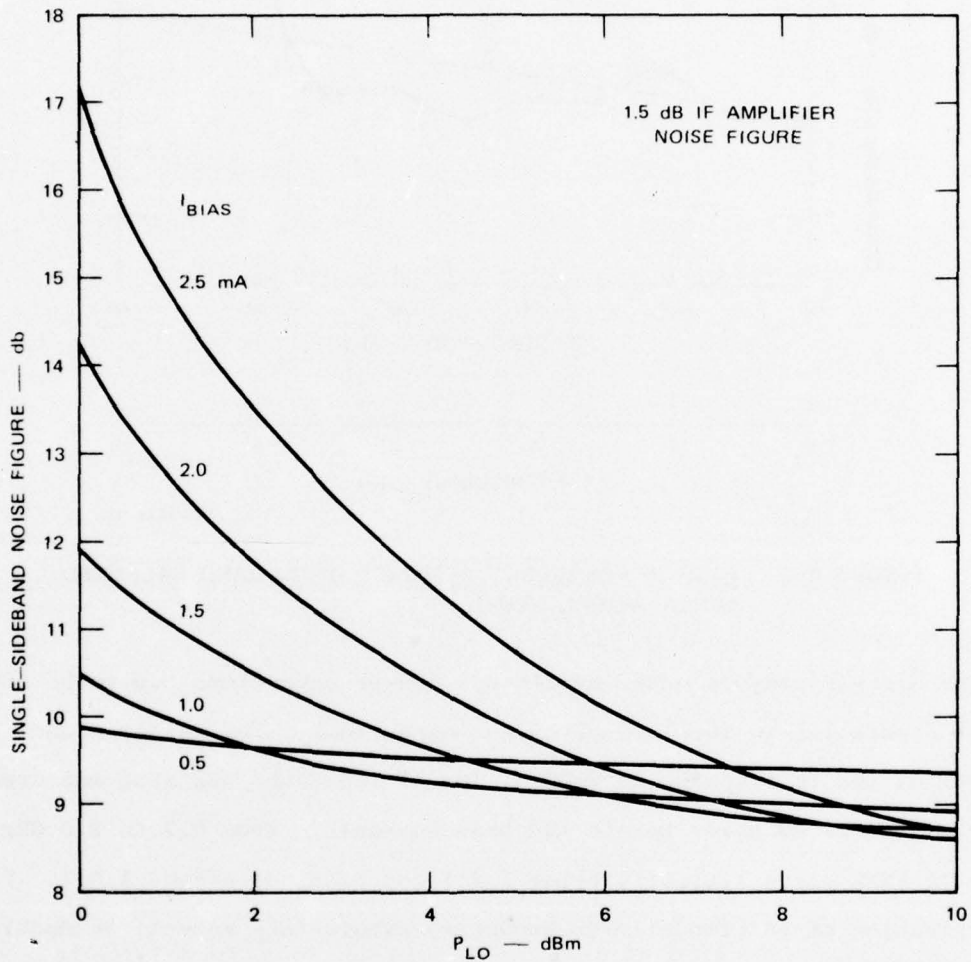

TA-652583-217

FIGURE III-8 NOISE FIGURE VERSUS LO POWER FOR Ka-BAND BALANCED MIXER, MODEL RBM-1

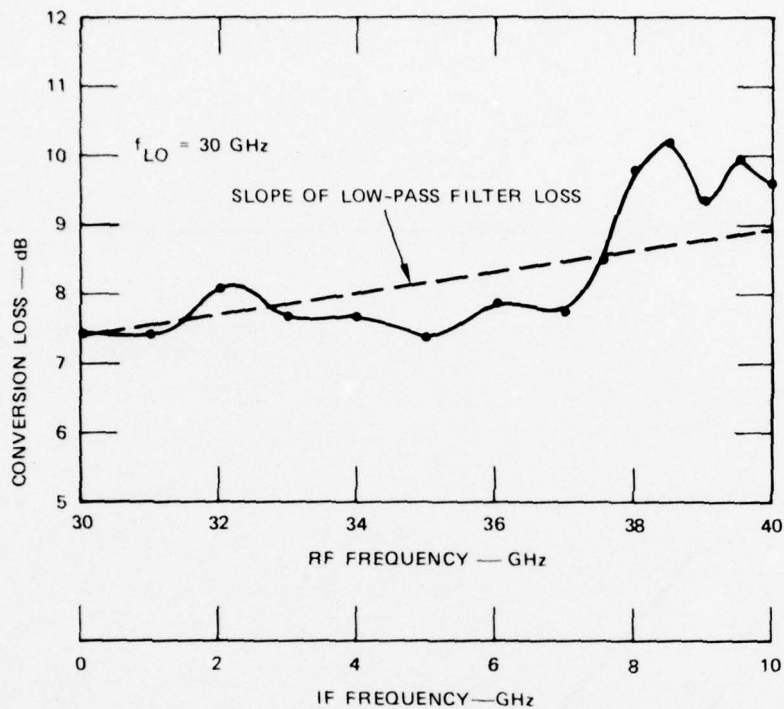

SA-3414-15

FIGURE III-9 HIGH IF FREQUENCY RESPONSE OF Ka-BAND BALANCED MIXER, MODEL RBM-2

these high-IF measurements, additional 100-pF capacitors had to be connected parallel to the 1000-pF bypass capacitors. The latter alone restrict the IF response to 2 GHz. The IF impedance was also measured for different LO power levels and bias currents. From 0.1 to 2.0 GHz, the IF VSWR stays typically below 1.3:1 and does not exceed 1.5:1. Finally, suppression of intermodulation products, single-tone as well as double-tone, is at least comparable to that of lower-frequency mixers at similar LO drive levels.

#### D. Design and Performance of Component Parts

In this section some of the detailed work that went into the design of the Ka-band balanced mixer is explained more carefully than was possible in Section III-B. As already pointed out, most component parts were initially built and tested in scale models at a lower frequency. For these models we used 1/16-inch copper-clad dielectric sheets with  $\epsilon_r = 4$  (which is close to the relative dielectric constant of quartz). This dictated a scale factor of 6.25 and scaled conveniently from Ka-band (WR 28) to C-band (WR 187). Some experiments were also conducted at X-band with a scale factor of 3.125. Only after satisfactory performance had been obtained with the scale model was a circuit at the actual frequency fabricated. The only element that is difficult to scale is the beam-lead mixer diode, which is available in one size only. The theoretical basis for scaling of microwave circuits can be found in Schneider.<sup>4</sup>

##### 1. LO-IF Diplexer

Initially, we determined experimentally the dimensions of a 50-ohm suspended substrate line and then designed the LO-bandpass filter. This filter is a three-section half-wave parallel-coupled line filter with the resonators printed alternatively on the top and the bottom side of the substrate. This design provides strong coupling between the resonators and relatively low capacitance to ground, a necessity for a wide-band filter of this type. Initial values for the filter parameters (Chebyshev with 0.1 dB ripple) were taken from existing design tables. However, because of the inhomogeneous dielectric of the coupled-line sections, the even- and odd-mode velocities are different. Therefore, the filter was analyzed and optimized using exact equivalent circuits for coupled-line sections in an inhomogeneous dielectric.<sup>5</sup> Because of the large difference in the mode velocities, the filter response deviates

significantly from that of a similar filter in a homogeneous medium. The final optimization of the filter was done in the scale-model experiment.

The IF low-pass filter is of the semilumped type and built in microstrip. The standard design procedure as outlined in Matthaei, Young, and Jones<sup>6</sup> was used. The design is based on a seven-section Chebyshev prototype with 0.01 dB ripple. The cutoff frequency is 10 GHz and in the center of the 26.5-to-40-GHz band the input impedance of the filter at the common junction of the diplexer is adjusted for an open circuit. The large separation of the two passbands makes the interconnection of the two filters easy. Nevertheless, the residual reactance of the bandpass filter was taken into account in the design of the low-pass filter and vice versa.

After the successful completion of scale-model experiments, an actual-size diplexer was fabricated and tested. The major results of these tests are shown in Figure III-10. The low-pass filter response is close to theoretical. The return loss is better than 20 dB (VSWR < 1.2:1) up to 7 GHz, but stays below 11 dB up to 10 GHz. The attenuation of the low-pass filter above 10 GHz increases monotonically and reaches close to 50 dB at 18 GHz. In the 26.5-to-40-GHz range, the attenuation exceeded the dynamic range of the measuring setup of 40 dB. The bandpass filter exhibits sufficient low-frequency attenuation to prevent any IF loss at the LO port up to the highest IF frequency of 10 GHz. In the passband, the return loss stays generally around 15 dB. This includes not only the reflections of the filter but also those of two suspended substrate-to-coax transitions, two pairs of MPC2 connector assemblies, and two MPC2-to-waveguide transitions. For comparison, a pair of MPC2 adapters with a 6-inch-long MPC2 cable assembly in between has a minimum return loss of 14 dB. When the 6-inch semirigid cable assembly is cut into two pieces and a 1-inch section of suspended-substrate line with two transitions from semirigid cable to suspended substrate is inserted, the total

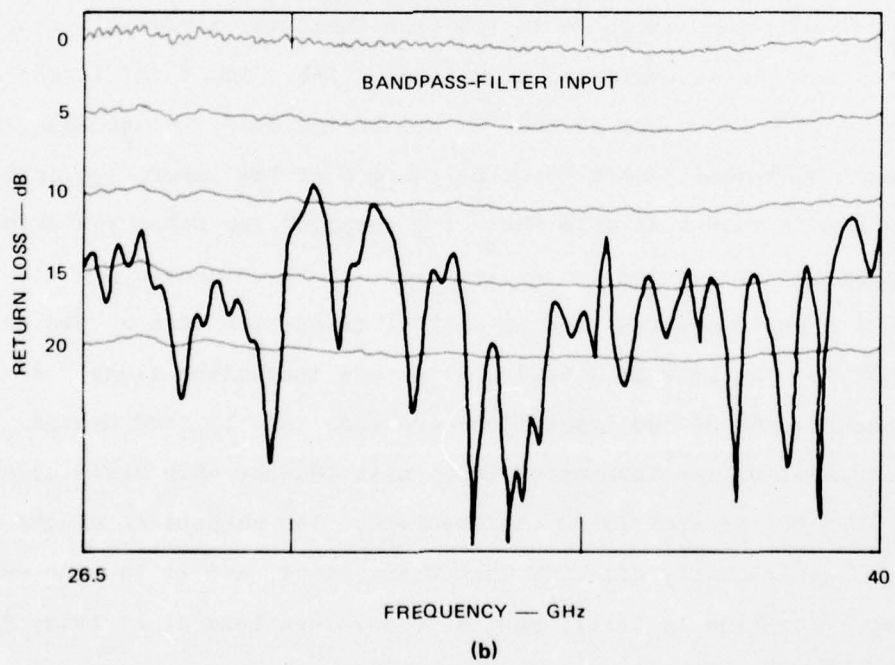
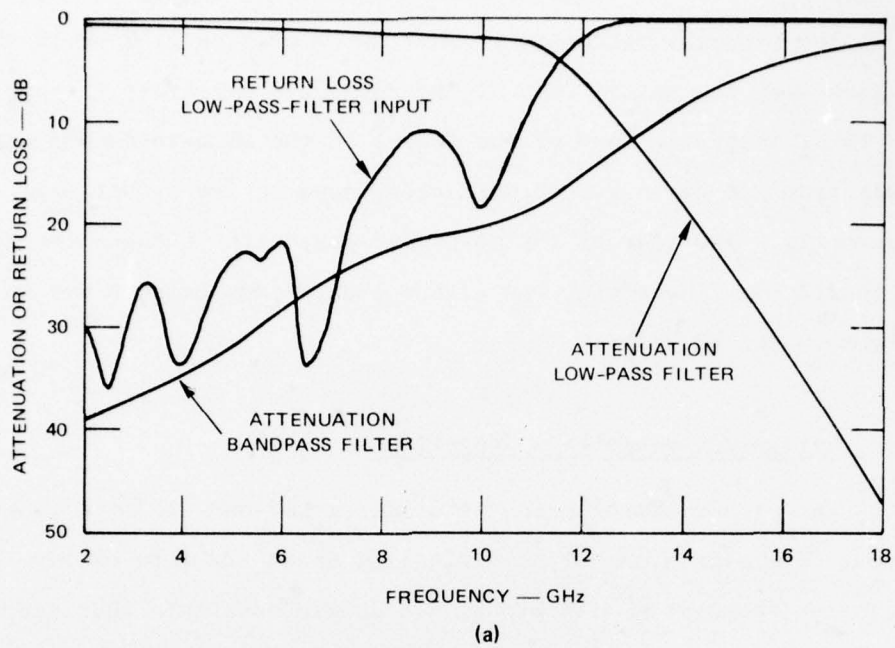

SA-3414-16

FIGURE III-10 MEASUREMENT RESULTS OF LO-IF DIPLEXER

return loss decreases to 11 dB minimum and 17 dB average. Hence, the effect of the bandpass filter is a small deterioration of 2 dB in the return loss over the return loss of the suspended substrate through-line alone. Total insertion loss of the filter in the 26.5-to-40-GHz band increases from 1.6 dB to 2.5 dB when referenced to the 6-inch semirigid cable assembly. The loss of the suspended-substrate through-line alone is 0.8 to 1.3 dB. Therefore, the filter itself adds between 0.7 to 1.2 dB of loss to the LO path.

## 2. Waveguide-to-Slotline Transition

For proper matching to the diodes a 100-ohm slotline impedance is needed. The dimensions of this slotline on quartz were extrapolated from data for substrates with higher dielectric constants than quartz and were verified experimentally (2 mil gap width on a 10-mil substrate). The transition from waveguide to slotline consists of a single step and a tapered section as explained in Section III-B. The total length of the transition is  $0.7\lambda$  in air at the low end of the band, but because the wavelength decreases toward the slotline end of the taper, the actual length is more than  $\lambda$  at 26.5 GHz. The shape of the taper was determined experimentally by testing two scaled transitions connected back-to-back. The model experiments resulted in a final transition with a VSWR below 1.5:1 max for the pair or 1.22:1 max for one transition alone. Actual-size measurements of the transition were made to a limited degree. A single transition was terminated in a small 100-ohm chip resistor and a return loss better than 13 dB was observed. The parasitics of the chip resistor significantly affected this measurement, and it is concluded that the transition by itself must have a return loss of at least 15 dB (VSWR  $< 1.43:1$ ). The losses of the transition were estimated by measuring the return loss of a short-circuited transition. They are less than 0.3 dB.

### 3. Diode-Matching-Network Design and Theoretical Conversion Loss

This subsection explains some of the considerations that went into the design of the diode-matching network and presents a theoretical estimation for the conversion loss. The conversion-loss calculations follow closely the work by Barber.<sup>3</sup> The equivalent circuit of the AEI diode is shown in Figure III-11 and it includes typical element values for the circuit parameters. All elements are considered constant, except for the junction resistance  $R_j$ , which varies periodically with the  $IO$  signal.

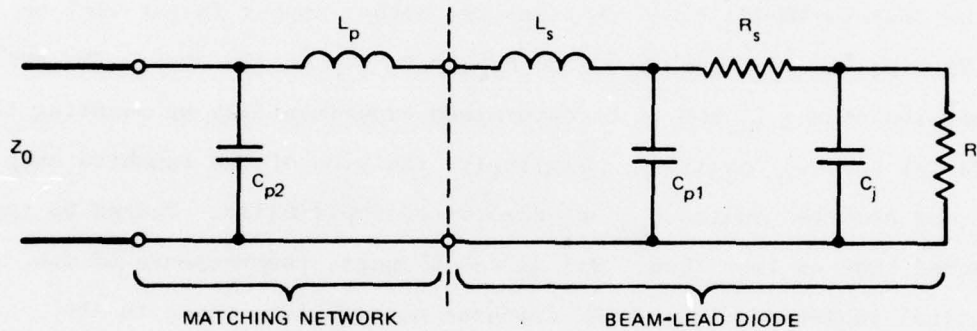

AEI DIODE	$C_j = 0.05 \text{ pF}$
	$R_s = 4\Omega$
	$C_{p1} = 0.01 \text{ pF}$
	$L_s = 0.1 \text{ nH}$

SA-3414-17

FIGURE III-11 EQUIVALENT CIRCUIT OF BEAM-LEAD DIODE AND MATCHING NETWORK

To obtain a good match to the RF port it is necessary to consider  $R_{RF}$ , the average value of  $R_j$  at the signal frequency. To minimize losses in  $R_s$ , the real part of the parallel connection of  $R_{RF}$  and  $C_j$  has to be maximized for the frequency of operation, which occurs at

$$R_{RF \text{ opt}} = \frac{1}{\omega_0 C_j}$$

Doing this at the upper bandedge of 40 GHz, one obtains  $R_{RF\ opt} = 80\ \text{ohms}$  for the AEI diode.

A matching network consisting of a series inductance,  $L_p$ , augmenting  $L_s$ , and a shunt capacitance,  $C_{p2}$ , transforms the diode network into a third-order lowpass filter. A computer optimization program was used to determine the optimum values of  $L_p$ ,  $C_{p2}$ , and the impedance of the input line,  $Z_0$ . For the diode parameters given above, the optimum matching-network parameters were found to be  $L_p = 0.32\ \text{nH}$ ,  $C_{p2} = 0.041\ \text{pF}$ , and  $Z_0 = 50\ \text{ohms}$ , which resulted in a maximum theoretical VSWR of 1.30:1 in the 26.5-to-40-GHz band. Because two diodes appear in parallel on the RF side the slotline impedance has to be  $2Z_0$  or 100 ohms. The additional inductance  $L_p$  had to be determined experimentally by mounting the diodes at various positions. Similarly, the size of the sapphire chip that was used to realize  $C_{p2}$  was determined empirically. Judged by the measured VSWR of less than 1.9:1 at the RF port, the response of the practical implementation of the matching network came close to the theoretically calculated value.

With  $R_{RF\ opt}$  determined, the characteristic conversion loss was calculated using Torrey and Whitmer's<sup>7</sup> results. However, instead of operating with the peak LO voltage, the pulse duty ratio (PDR), as introduced by Barber<sup>3</sup> was used. Based on an incident LO power of 2 mW, a PDR = 0.25 was estimated. This results in a characteristic conversion loss (that of an ideal diode without  $R_s$ ) of 4.6 dB. The value of the junction resistance, which is seen by the LO signal, is then calculated to be  $R_{RF\ opt} / 1.33 = 60\ \text{ohms}$  and the IF impedance is 108 ohms. Because two diodes appear in parallel on the LO and IF side, the real part of the LO impedance is 30 ohms and the IF impedance is a very convenient 54 ohms. Both values agree closely with the measured VSWRs.

In addition to the characteristic loss, further losses are incurred due to  $R_s$ , mismatches on the RF and IF side, and circuit losses. The following table summarizes all of the losses contributing to the total theoretical conversion loss:

Characteristic loss	4.6 dB
Loss due to $R_s$	0.6 dB
Mismatch losses	0.1 dB
Circuit losses	<u>0.8 dB</u>
Total theoretical conversion loss	6.1 dB

Mismatch losses are calculated based on the equivalent circuit. The circuit losses are those measured on the component parts. The discrepancy of 1 to 2 dB between the total theoretical conversion loss and the measured conversion loss (Figure III-5) can be attributed to four factors. First, in estimating the PDR, the effect of  $R_s$ , which increases the PDR, and therefore also the conversion loss was neglected. Second, the actual mismatch losses are higher, up to 0.5 dB. Third, the circuit losses of the matching network are not included, but are estimated to be significant. In some cases the conversion loss was found to increase by as much as 0.5 dB as soon as the sapphire chip was bonded to the circuit. Finally, the termination of the sum frequency,  $f_{LO} + f_{RF}$ , is not lossless, and energy converted to this frequency is lost for conversion to the desired IF frequency. The best spot conversion loss was 6.7 dB, obtained in a second mixer unit; however, the overall response of this mixer was not as good as that reported in Section III-C.

#### E. Conclusions

It has been demonstrated that planar techniques and GaAs beam-lead Schottky-barrier diodes with very high cutoff frequencies make

full-waveguide-band balanced mixers possible. The planar technique is not only advantageous from a production and size point of view; it is essential for the wide-bandwidth capability of this mixer. Several techniques that have been explored previously but at much lower frequencies have proven to be fully usable at millimeter-wave frequencies. Among these is the use of a coplanar-waveguide slotline hybrid junction, the design of diode-matching networks by computer optimization, and the successful implementation of the matching network. Conversion loss and noise figure of the mixer are not as good as those usually obtained in waveguide mixers. However, the performance is excellent if compared with similar MIC balanced mixers at lower frequencies. The inherent isolation between the LO and RF port is reflected in the good isolation between the LO and RF port that was measured in the actual mixer. Further work is required to reduce the losses in the LO path, particularly at the high end of the band. Reducing the losses should make operation of the mixer with 1-mW incident power with a low noise figure feasible. In the present unit, insufficient pump power in the upper half of the RF band increases the conversion loss to 10.2 dB at 40 GHz (1 mA bias current). In addition, a replacement for the sapphire chip used to match the diodes is desirable, possibly in the form of an interdigital capacitor.

Extension of the design concept of the Ka-band mixer to higher frequencies appears feasible. With the existing AEI Schottky-barrier diodes, coverage of the full 40-to-60-GHz band is possible. However, because of the lower impedance levels required for the RF slotline as well as for the LO coplanar waveguide, a higher dielectric substrate such as sapphire is recommended. Modified designs with waveguide inputs for the RF and the LO signal are possible without changing the basic concept of the mixer. Finally, it appears possible to use the design in an extension to an image-enhanced and image-reject mixer.

#### REFERENCES

1. W. M. Sharpless, "Wafer Type Millimeter Wave Rectifiers," Bell Syst. Tech. J., Vol 35, No. 6, pp. 1385-1402 (November 1956).
2. B. Schiek, "Hybrid Branchline Couplers--A Useful New Class of Directional Couplers," IEEE Trans. Microwave Theory and Techniques, Vol. MTT-22, No. 10, pp. 864-869 (October 1974).
3. M. R. Barber, "Noise Figure and Conversion Loss of the Schottky Barrier Mixer Diode," IEEE Trans. Microwave Theory and Techniques, Vol. MTT-15, No. 11, pp. 629-635 (November 1967).
4. M. V. Schneider, "Millimeter Wave Integrated Circuits," 1973 IEEE G-MTT International Microwave Symposium, Boulder, Colorado (June 1973).
5. G. I. Zysman and A. K. Johnson, "Coupled Transmission Line Networks in an Inhomogeneous Dielectric Medium," IEEE Trans. Microwave Theory and Techniques, Vol. MTT-17, No. 10, pp. 753-759 (October 1969).
6. G. L. Matthaei, L. Young, and E.M.T. Jones, Microwave Filters, Impedance Matching Networks and Coupling Structures (McGraw-Hill Book Company, New York, N.Y., 1964).
7. H. C. Torrey and C. A. Whitmer, "Crystal Rectifiers," MIT Rad. Lab. Series, Vol. 15 (McGraw-Hill Book Company, New York, N.Y., 1948).

Appendix A

OPERATING INSTRUCTIONS FOR THE K-BAND, MIC,  
IMAGE-REJECT MIXER, MODEL KIRM-2(2)

Appendix A  
OPERATING INSTRUCTIONS FOR THE K-BAND, MIC,  
IMAGE-REJECT MIXER, MODEL KIRM-2(2)

1. Description

a. General

The K-band (18.0- to 26.5-GHz) MIC, Image-Reject Mixer utilizes the latest microwave integrated circuit techniques to realize for the first time a broadband, image-reject mixer covering the entire K band. The mixer design is such that conversion loss is degraded only slightly (<1 dB) for LO power variations of 10 dB. Specifications are shown in Table A-1. Figure A-1 is a photograph of the completed mixer, and Figure A-2 shows the assembled layout.

Table A-1  
SPECIFICATIONS OF K-BAND  
IMAGE-REJECT MIXER

<b>Specifications</b>	
RF frequency range:	18.0-26.5 GHz
LO power range:	3-10 dBm
IF frequency:	168 MHz
IF bandwidth:	110 MHz
<b>Connector type</b>	
RF port	MPC 2 (male)
LO port	MPC 2 (male)
IF ports	SMA (female)
<b>Power-supply requirements</b>	
Normal operation:	
+15 ± 5% volts at 2 mA	
-15 ± 5% volts at 2 mA	
Absolute maximum:	
±25 volts	



SA-3414-17

FIGURE A-1 K-BAND (18.0 to 26.5 GHz), MIC, IMAGE-REJECT MIXER, MODEL KIRM-2(2)

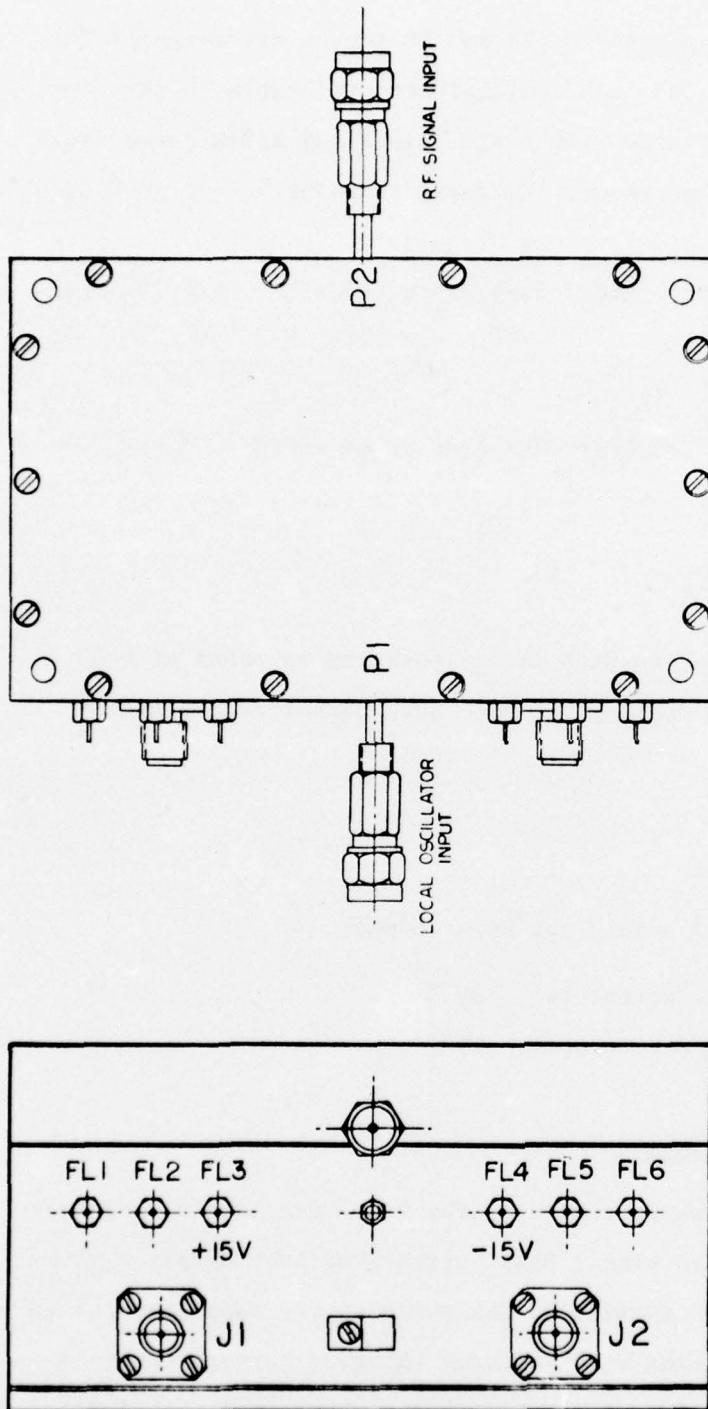

I. J1 IS REAL I.F. OUTPUT FOR  $F_{L0} > F_{RF}$ .

ITEM	QTY	DESCRIPTION	DATE	BY	REV.
MATERIAL					
PROBING					
DATE	12-27-74				
DESIGNER	J. L. DICKINSON				
APP'D					
STANFORD RESEARCH INSTITUTE MENLO PARK, CALIF.					
DRAWING NO. C-3414-47					

FIGURE A-2 K-BAND MIC IMAGE-REJECT-MIXER CONNECTOR LAYOUT

b. Connectors

RF and LO Connectors--The RF and LO inputs are designed for connecting directly to 0.085-inch semirigid coaxial cable so that the mixer can be easily integrated with a YIG filter and a YIG-tuned local oscillator. For testing purposes, the coaxial cables have been fitted with Type MPC2 male connectors (Maury Microwave Corporation) and mated with the waveguide to female MPC2 coax adapter Model No. SK8012A from Maury Microwave Corporation.

IF Connectors--The real- and image-port connectors are female SMA type.

c. Mounting

The mixer may be mounted in any position by means of 4-40 screws through the four mounting holes in each corner of the image-reject-mixer box.

2. Environmental Limits

The following limits should not be exceeded:

- Maximum storage temperature 80°C
- Minimum storage temperature -20°C

3. Power-Supply Requirements

For optimized performance, each of the four mixer diodes requires approximately 1 mA forward bias. Bias currents must be supplied from two external 15-Vdc power supplies. One power supply supplies bias current to the two mixer diodes with grounded cathodes through the feed-through labeled +15 V (FL3 on connector layout shown in Figure A-2).

The negative terminal of this supply is connected to the frame ground of the mixer assembly.

The second supply supplies bias currents to the two mixer diodes with grounded anodes through the feedthrough labeled -15 V (FL4). The positive terminal of this supply is connected to frame ground.

Approximately 2 mA will be drawn from each supply when adjusted to 15 V.

#### 4. Operation

Before placing the K-band image-reject mixer into operation, review the general precautions noted in Section 5 of this appendix. Then proceed with the following steps:

- (1) Connect power supplies.
- (2) Measure currents from each power supply while increasing voltages from zero to 15 volts. Currents should increase with voltage to a value of approximately 2 mA for each supply.
- (3) Measure each diode voltage while full bias current is applied. The diode bias voltages are brought out through feedthroughs labeled FL1, FL2, FL5, and FL6. Using a meter with at least 1 megohm input impedance, the diode voltages should measure as follows:

<u>Feedthrough Number</u>	<u>Voltage to Frame Ground</u>
FL1	-0.6 to -0.7 V
FL2	+0.6 to +0.7 V
FL5	+0.6 to +0.7 V
FL6	-0.6 to -0.7 V

- (4) Connect local-oscillator sources of 0 to 6 dBm power output to the coaxial connector (MPC2) labeled P1. The LO input is on the same side of the mixer assembly as the feedthrough terminals and IF output connectors.

- (5) Connect RF signal source to coaxial connector (MPC2) labeled P2--opposite LO input. The difference between the LO and RF frequencies must be 168 MHz.
- (6) Connect 168-MHz amplifiers with 50-ohm input impedance or 50-ohm loads as appropriate to IF output Ports J1 and J2 (Figure 2). The real and image signals will appear at Ports J1 and J2 as follows:

	J1	J2
$f_{LO} > f_{RF}$	Real signal	Image signal
$f_{RF} > f_{LO}$	Image signal	Real signal

#### 5. Precautions

The procedures discussed in the following should be noted and applied during handling, installation, and operation of the K-band image-reject mixer:

- (1) Mixer diodes may be damaged by static discharges. While each mixer diode in the image-reject mixer is buffered by resistors and heavily bypassed, all leads should be grounded to the mixer case before connecting to the feedthrough terminals. Soldering-iron power cords should be disconnected from the power source and connected to the mixer case immediately prior to and during soldering to feedthrough terminals. All coax cables should be discharged by connecting the shield and center conductors simultaneously to the mixer case prior to connection to the mixer ports.
- (2) It is recommended that the feedthrough terminals be connected by flexible wires to a solidly mounted terminal strip if frequent connection changes are contemplated. Connections can then be made at the terminal strip. Because the feedthroughs are necessarily small, they should be protected from mechanical strain or repeated flexing to prevent breaking the small center conductor.

- (3) The LO input port (P1) and the RF input port (P2) of the image-reject mixer are fitted with MPC2 connectors. These connectors do not mate properly with SMA type connectors although the nuts are the same. Attempts to force a mate could result in damage to the connectors. The MPC2 connector is of much higher precision than the SMA type connector and is necessary at K and Ka bands in order to achieve good performance.
- (4) The RF and LO inputs to the K-band mixer are in 0.085-inch coaxial cable for easy integration with YIG-tuned elements. Care should be exercised when connecting the RF and LO inputs to signal sources so that the cables are not bent or placed in torsional strain. Any bends, small kinks, or twists can have degrading effects on the mixer performance.
- (5) The mixer has four adjustable pots under the bottom cover for adjusting the individual diode currents for optimum performance. These pots have been set and cemented in the optimum position for each diode. It is recommended that these pots not be adjusted in the field because proper settings can be obtained only through a specific test procedure requiring specialized test equipment.

Appendix B

FINAL TECHNICAL PERFORMANCE MEASUREMENT COMPARISON  
FOR THE K-BAND, MIC, IMAGE-REJECT MIXER, MODEL KIRM-2(2).

Appendix B

FINAL TECHNICAL PERFORMANCE MEASUREMENT COMPARISON  
FOR THE K-BAND, MIC, IMAGE-REJECT MIXER, MODEL KIRM-2(2).

1. Introduction

Performance goals for the K-band, MIC, image-reject mixer are as follows:\*

• Input LO power level	0 dBm minimum +6 dBm maximum
• LO-port VSWR	3.0:1 maximum 2.5:1 typical
• RF-port VSWR	3.0:1 maximum 2.5:1 typical
• IF-port VSWR	2.0:1 maximum 2.5:1 typical
• Conversion loss, RF to IF at $f_{IF} = 168$ MHz (IF bandwidth 110 MHz)	9.5 dB maximum 8.5 dB typical
• Noise figure (using 1.5 dB noise figure, IF amplifier at 168 MHz, IF bandwidth is 110 MHz)	11.0 dB maximum 10.0 dB typical
• LO-to-RF isolation	11.0 dB maximum 13.0 dB typical
• 2 x 2 balance	35.0 dB minimum 40.0 dB typical
• Image rejection	15.0 dB minimum 20.0 typical

Because some of the performance goals are in terms of maximum values (conversion loss, for example) and others are in terms of minimum values

---

\* From SRI Proposal ERU 73-210, Section IV-D.

(image rejection, for example), the following convention is established with regard to the listed "demonstrated variance:"

- (1) For performance goals with a maximum upper bound.
  - (a) A positive (+) demonstrated variance indicates a demonstrated value greater than the maximum performance goal. The demonstrated performance does not meet the anticipated goal.
  - (b) A negative (-) demonstrated variance indicates a demonstrated value less than the maximum performance goal. The demonstrated performance meets the anticipated goal.
- (2) For performance goals with a minimum lower bound.
  - (a) A positive (+) demonstrated variance indicates a demonstrated value greater than the minimum performance goal. The demonstrated performance meets the anticipated goal.
  - (b) A negative (-) demonstrated variance indicates a demonstrated value less than the minimum performance goal. The demonstrated performance does not meet the anticipated goal.

The convention is summarized in the following tabulation:

Planned Value	Demonstrated Variance	Demonstrated Performance Relative to Goal
Max	+	Does not meet anticipated goal
	-	Does meet anticipated goal
Min	+	Does meet anticipated goal
	-	Does not meet anticipated goal

## 2. Technical Performance Measurement Comparison

The final measured performance of the K-band, MIC, image-reject mixer [SNR KIRM-2(2)] is compared to the design goals on the following log sheets. Data are included for three local-oscillator drive levels: 0, +3, and +6 dBm. All data at 0-dBm LO drive are presented first, followed successively by data at +3 dBm and +6 dBm LO drive levels.

TECHNICAL PERFORMANCE MEASUREMENT COMPARISON

K-Band, MIC, Image Reject Mixer  
(Final Product)

KIRM-2(2)

Date: 12/27/74

LO Power = 0 dBm.

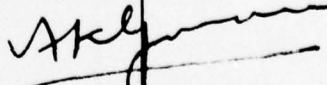
Parameter	Planned Value	Frequency GHz.	Demonstrated Value	Demonstrated Variance
LO Port VSWR	3.0:1 Max.	18.0	1.25	-1.75
		19.0	1.79	-1.21
		20.0	1.67	-1.33
		21.0	1.67	-1.33
		22.0	1.60	-1.40
		23.0	1.30	-1.70
		24.0	1.30	-1.70
		25.0	1.22	-1.78
		26.0	1.25	-1.75
		26.5	1.50	-1.50
		Approved by:	<p align="center">D.R. Chaney                        APPROVED.</p>	
<p>(-) variance indicates demonstrated value meets the anticipated goal.</p>				

TECHNICAL PERFORMANCE MEASUREMENT COMPARISON

K-Band, MIC, Image Reject Mixer  
(Final Product)

KIRM-2(2)

Date: 12/27/74

LO Power = 0 dBm.

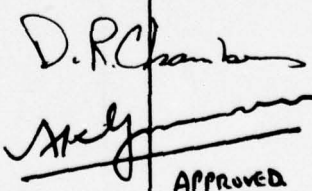
Parameter	Planned Value	Frequency GHz.	Demonstrated Value	Demonstrated Variance
RF Port VSWR	3.0:1 Max.	18.0	1.30	-1.70
		19.0	1.30	-1.70
		20.0	1.62	-1.38
		21.0	2.10	-0.90
		22.0	1.80	-1.20
		23.0	2.33	-0.67
		24.0	1.20	-1.80
		25.0	1.78	-1.22
		26.0	1.65	-1.35
		26.5	1.95	-1.05
Approved by:			 Approved	
(-) variance indicates demonstrated value meets the anticipated goal.				

TECHNICAL PERFORMANCE MEASUREMENT COMPARISON

K-Band, MIC, Image Reject Mixer

(Final Product)

KIRM-2(2)

Date: 1/16/75

LO Power = 0 dBm.

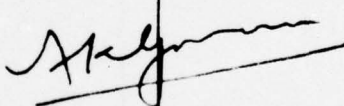
Parameter	Planned Value	Frequency MHz.	Demonstrated Value	Demonstrated Variance
IF Port VSWR	2.5:1 Max.	112	1.42	-1.08
		140	1.33	-1.17
		168	1.22	-1.28
		196	1.21	-1.29
		224	1.19	-1.31
			D.R. Chan	
			Approved by: 	
(-) variance indicates demonstrated value meets the anticipated goal.				

TECHNICAL PERFORMANCE MEASUREMENT COMPARISON

K-Band, MIC, Image Reject Mixer  
(Final Product)

KIRM-2(2)

Date: 1-15-75

LO Power = 0 dBm.

Parameter	Planned Value dB.	Frequency GHz.	Demonstrated Value dB.	Demonstrated Variance dB.
Conversion Loss	9.5 dB. Max.	18.0	7.8	-1.7
		19.0	8.1	-1.4
		20.0	8.4	-1.1
		21.0	8.8	-0.7
		22.0	8.6	-0.9
		23.0	8.0	-1.5
		24.0	8.0	-1.5
		25.0	8.5	-1.0
		26.0	9.5	0
		26.5	10.5	+1.0
Noise Figure	11.0 dB. Max.	25.0	10.3	-0.7

Approved by:

*D.R. Chan*  
*Alcyon*

(-) variance indicates demonstrated value meets the anticipated goal.

TECHNICAL PERFORMANCE MEASUREMENT COMPARISON

K-Band, MIC, Image Reject Mixer

(Final Product)

KIRM-2(2)

Date: 12/27/74

LO Power = 0 dBm.

Parameter	Planned Value dB.	Frequency GHz.	Demonstrated Value dB.	Demonstrated Variance dB.
LO to RF Isolation	11.0 dB. Max.	18.0	16.0	-5.0
		19.0	16.5	-5.5
		20.0	16.5	-5.5
		21.0	16.5	-5.5
		22.0	18.5	-7.5
		23.0	25.0	-14.0
		24.0	28.0	-17.0
		25.0	19.0	-8.0
		26.0	14.0	-3.0
		26.5	14.5	-3.5
Approved by:			<i>D.R. Chambers</i>	
			<i>Aky</i>	
(-) variance indicates demonstrated value meets the anticipated goal.				

TECHNICAL PERFORMANCE MEASUREMENT COMPARISON

K-Band, MIC, Image Reject Mixer  
(Final Product)

KIRM-2(2)

Date: 1/16/75

LO Power = 0 dBm.

Parameter	Planned Value dB.	Frequency GHz.	Demonstrated Value dB.	Demonstrated Variance dB.
2 x 2 Spurious	35.0 dB. Min.	18.0	42	+7
		19.0	45	+10
		20.0	55	+20
		21.0	52	+17
		22.0	44	+9
		23.0	44	+9
		24.0	46	+11
		25.0	47	+12
		26.0	52	+17
		26.5	50	+15
		Approved by:	<p align="center">D.R. Chamber <i>[Signature]</i></p>	
<p>(+) variance indicates demonstrated value meets the anticipated goal.</p>				

TECHNICAL PERFORMANCE MEASUREMENT COMPARISON

K-Band, MIC, Image Reject Mixer  
(Final Product)

KIRM-2(2)

Date: 1-15-75

LO Power = 0 dBm.

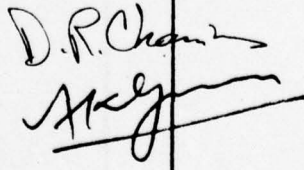
Parameter	Planned Value dB.	Frequency GHz.	Demonstrated Value dB.	Demonstrated Variance dB.
Image Rejection	15.0 dB. Min.	18.0	22	+7
		19.0	40	+25
		20.0	33	+18
		21.0	22	+7
		22.0	16	+1
		23.0	20	+5
		24.0	22	+7
		25.0	20	+5
		26.0	22	+7
		26.5	20	+5
Approved by:				
(+) variance indicates demonstrated value meets the anticipated goal.				

TECHNICAL PERFORMANCE MEASUREMENT COMPARISON

K-Band, MIC, Image Reject Mixer

(Final Product)

KIRM-2(2)

Date: 12/27/74

LO Power = +3 dBm.

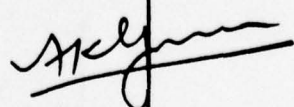
Parameter	Planned Value	Frequency GHz.	Demonstrated Value	Demonstrated Variance
LO Port VSWR	3.0:1 Max.	18.0	1.30	-1.70
		19.0	1.85	-1.15
		20.0	1.68	-1.32
		21.0	1.68	-1.32
		22.0	1.58	-1.42
		23.0	1.38	-1.62
		24.0	1.15	-1.85
		25.0	1.25	-1.75
		26.0	1.15	-1.85
		26.5	1.50	-1.50
Approved by:			<p align="right">D.R. Chank  </p>	
(-) variance indicates demonstrated value meets the anticipated goal.				

TECHNICAL PERFORMANCE MEASUREMENT COMPARISON

K-Band, MIC, Image Reject Mixer  
(Final Product)

KIRM-2(2)

Date: 12/27/74

LO Power = +3 dBm.

Parameter	Planned Value	Frequency GHz.	Demonstrated Value	Demonstrated Variance
RF Port VSWR	3.0:1 Max.			
		18.0	1.30	-1.70
		19.0	1.22	-1.78
		20.0	1.72	-1.28
		21.0	2.10	-0.90
		22.0	1.63	-1.37
		23.0	2.32	-0.68
		24.0	1.25	-1.75
		25.0	1.72	-1.28
		26.0	1.58	-1.42
		26.5	1.88	-1.12

D.R. Chaney  
~~\_\_\_\_\_~~

Approved by:

(-) variance indicates demonstrated value meets the anticipated goal.

TECHNICAL PERFORMANCE MEASUREMENT COMPARISON

K-Band, MIC, Image Reject Mixer  
(Final Product)

KIRM-2(2)

Date: 1/16/75

LO Power = +3 dBm.

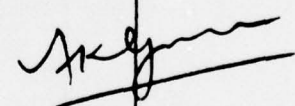
Parameter	Planned Value	Frequency MHz.	Demonstrated Value	Demonstrated Variance
IF Port VSWR	2.5:1 Max.	112	1.50	-1.0
		140	1.38	-1.12
		168	1.29	-1.21
		196	1.25	-1.25
		224	1.22	-1.28
			DRC  Approved by:	
(-) variance indicates demonstrated value meets the anticipated goal.				

TECHNICAL PERFORMANCE MEASUREMENT COMPARISON

K-Band, MIC, Image Reject Mixer  
(Final Product)

KIRM-212)

Date: 1/15/75

LO Power = +3 dBm.

Parameter	Planned Value dB.	Frequency GHz.	Demonstrated Value dB.	Demonstrated Variance dB.
Conversion Loss	9.5 dB. Max.	18.0	7.8	-1.7
		19.0	7.8	-1.7
		20.0	7.9	-1.6
		21.0	8.4	-1.1
		22.0	8.1	-1.4
		23.0	7.6	-1.9
		24.0	7.5	-2.0
		25.0	7.8	-1.7
		26.0	8.8	-0.7
		26.5	9.5	0

Approved by:

*D.R. Chan*  
*[Signature]*

(-) variance indicates demonstrated value meets the anticipated goal.

TECHNICAL PERFORMANCE MEASUREMENT COMPARISON

K-Band, MIC, Image Reject Mixer

(Final Product)

KIRM-2(2)

Date: 12/27/74

LO Power = +3 dBm.

Parameter	Planned Value dB.	Frequency GHz.	Demonstrated Value dB.	Demonstrated Variance dB.
LO to RF Isolation	11.0 dB. Max.	18.0	12.5	-1.5
		19.0	13.0	-2.0
		20.0	14.0	-3.0
		21.0	14.5	-3.5
		22.0	17.0	-6.0
		23.0	30	-19
		24.0	30	-19
		25.0	16.0	-5.0
		26.0	14.0	-3.0
		26.5	14.0	-3.0

Approved by:

*D.R. Chan*  
*[Signature]*

(-) variance indicates demonstrated value meets the anticipated goal.

TECHNICAL PERFORMANCE MEASUREMENT COMPARISON

K-Band, MIC, Image Reject Mixer  
(Final Product)

KIRM-2(2)

Date: 1/15/75

LO Power = +3 dBm.

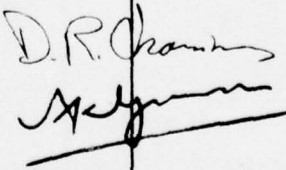
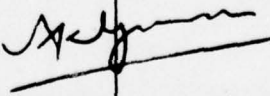
Parameter	Planned Value dB.	Frequency GHz.	Demonstrated Value dB.	Demonstrated Variance dB.
2 x 2 Spurious	35.0 dB. Min.	18.0	42	+7
		19.0	45	+10
		20.0	50	+15
		21.0	54	+19
		22.0	44	+9
		23.0	44	+9
		24.0	44	+9
		25.0	46	+11
		26.0	48	+13
		26.5	46	+11
		Approved by:	<p align="center">    </p>	
<p>(*) variance indicates demonstrated value meets the anticipated goal.</p>				

TECHNICAL PERFORMANCE MEASUREMENT COMPARISON

K-Band, MIC, Image Reject Mixer  
(Final Product)

KIRM-2(2)

Date: 1/15/75

LO Power = + 3 dBm.

Parameter	Planned Value dB.	Frequency GHz.	Demonstrated Value dB.	Demonstrated Variance dB.
Image Rejection	15 dB. Min.	18.0	22	+7
		19.0	36	+21
		20.0	32	+17
		21.0	25	+10
		22.0	18	+3
		23.0	18	+3
		24.0	22	+7
		25.0	24	+9
		26.0	24	+9
		26.5	24	+9
		Approved by:	<p align="right"><i>D.R. Chandra</i> <i>A.K.G.</i></p>	
<p>(+) variance indicates demonstrated value meets the anticipated goal.</p>				

TECHNICAL PERFORMANCE MEASUREMENT COMPARISON

K-Band, MIC, Image Reject Mixer

(Final Product)

KIRM-2(2)

Date: 12/27/74

LO Power = 6.0 dBm.

Parameter	Planned Value	Frequency GHz.	Demonstrated Value	Demonstrated Variance
LO Port VSWR	3.0:1 Max.	18.0	1.38	-1.62
		19.0	1.92	-1.08
		20.0	1.78	-1.22
		21.0	1.78	-1.22
		22.0	1.54	-1.46
		23.0	1.38	-1.62
		24.0	1.22	-1.78
		25.0	1.32	-1.68
		26.0	1.24	-1.76
		26.5	1.50	-1.50
			D.R. Chambers <i>[Signature]</i>	
			Approved by:	
(-) variance indicates demonstrated value meets the anticipated goal.				

TECHNICAL PERFORMANCE MEASUREMENT COMPARISON

K-Band, MIC, Image Reject Mixer  
(Final Product)

KIRM-2(2)

Date: 12/27/74

LO Power = +6.0 dBm.

Parameter	Planned Value	Frequency GHz.	Demonstrated Value	Demonstrated Variance
RF Port VSWR	3.0:1 Max.	18.0	1.29	-1.71
		19.0	1.22	-1.78
		20.0	1.87	-1.13
		21.0	2.32	-0.68
		22.0	1.46	-1.54
		23.0	2.60	-0.40
		24.0	1.38	-1.62
		25.0	1.87	-1.13
		26.0	1.54	-1.46
		26.5	1.67	-1.33
		Approved by:		
(-) variance indicates demonstrated performance meets the anticipated goal.				

TECHNICAL PERFORMANCE MEASUREMENT COMPARISON

K-Band, MIC, Image Reject Mixer

(Final Product)

KIPM-2(2)

Date: 1/15/75

LO Power = +6 dBm.

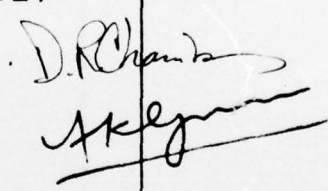
Parameter	Planned Value	Frequency Mhz.	Demonstrated Value	Demonstrated Variance
IF Port VSWR	2.5:1 Max.	112	1.63	-0.87
		140	1.38	-1.12
		168	1.35	-1.15
		196	1.31	-1.19
		224	1.29	-1.21
		Approved by:		
(-) variance indicates demonstrated value meets the anticipated goal.				

TECHNICAL PERFORMANCE MEASUREMENT COMPARISON

K-Band, MIC, Image Reject Mixer

(Final Product)

KIRM-2(2)

Date: 12/27/74

LO Power = +6 dBm.

Parameter	Planned Value dB.	Frequency GHz.	Demonstrated Value dB.	Demonstrated Variance dB.
Conversion Loss	9.5 dB. Max.	18.0	7.6	-1.9
		19.0	7.8	-1.7
		20.0	7.9	-1.6
		21.0	8.4	-1.1
		22.0	8.0	-1.5
		23.0	7.8	-1.7
		24.0	7.5	-2.0
		25.0	7.8	-1.7
		26.0	8.7	-0.8
		26.5	9.5	0
Noise Figure	11.0 dB. Max.	25.0	9.9	-1.1

Approved by:

*D.R. Chambers*  
*A. [Signature]*

(-) variance indicates demonstrated value meets the anticipated goal.

TECHNICAL PERFORMANCE MEASUREMENT COMPARISON

K-Band, MIC, Image Reject Mixer

(Final Product)

KIRM-2(2)

Date: 12/27/74

LO Power = +6.0 dBm.

Parameter	Planned Value	Frequency GHz.	Demonstrated Value dB.	Demonstrated Variance dB.
LO to RF Isolation	11.0 dB. Max.	18.0	10.0	+1.0
		19.0	10.0	+1.0
		20.0	11.5	-0.5
		21.0	12.0	-0.1
		22.0	14.5	-4.5
		23.0	21.0	-11.0
		24.0	22.0	-12.0
		25.0	15.0	-5.0
		26.0	14.0	-4.0
		26.5	14.0	-4.0

D.R. Chamber  
*[Signature]*

Approved by:

(-) variance indicates demonstrated value meets the anticipated goal.

TECHNICAL PERFORMANCE MEASUREMENT COMPARISON

K-Band, MIC, Image Reject Mixer

(Final Product)

KRM-2(2)

Date: 1/15/75

LO Power = +6 dBm.

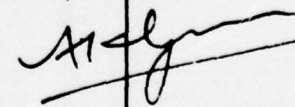
Parameter	Planned Value dB.	Frequency GHz.	Demonstrated Value dB.	Demonstrated Variance dB.
2 x 2 Spurious	35.0 dB. Min.	18.0	44	+9
		19.0	44	+9
		20.0	54	+19
		21.0	55	+20
		22.0	44	+9
		23.0	45	+10
		24.0	45	+10
		25.0	46	+11
		26.0	56	+21
		26.5	50	+15
		Approved by:	<p align="right">D.R. Chambers  </p>	
<p>(+) variance indicates demonstrated value meets the anticipated goal.</p>				

TECHNICAL PERFORMANCE MEASUREMENT COMPARISON

K-Band, MIC, Image Reject Mixer  
(Final Product)

KIRM-2(2)

Date: 1/15/75

LO Power = +6 dBm.

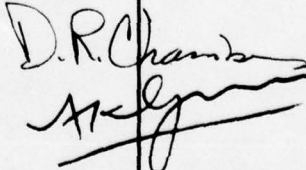
Parameter	Planned Value dB.	Frequency GHz.	Demonstrated Value dB.	Demonstrated Variance dB.
Image Rejection	15.0 dB. Min.	18.0	19	+4
		19.0	38	+23
		20.0	27	+12
		21.0	28	+13
		22.0	19	+4
		23.0	18	+3
		24.0	26	+11
		25.0	26	+11
		26.0	24	+9
		26.5	23	+8
		Approved by:		
(+) variance indicates demonstrated value meets the anticipated goal.				

Appendix C

OPERATING INSTRUCTIONS FOR THE Ka-BAND, BALANCED MIXER,  
MODEL RBM-1

Appendix C

OPERATING INSTRUCTIONS FOR THE Ka-BAND, BALANCED MIXER,  
MODEL RBM-1

1. Description

a. General

The Ka-band (26.5-to-40.0-GHz) MIC, Balanced Mixer utilizes the latest microwave integrated-circuit techniques to realize for the first time a broadband, balanced mixer covering the entire Ka-band. Specifications are shown in Table C-1.

Table C-1

SPECIFICATIONS OF Ka-BAND IMAGE-REJECT MIXER

<u>Specifications</u>	
RF Frequency Range:	26.5-40 GHz
LO Power Range:	3-10 dBm
IF Frequency Range:	0.03-2 GHz (without blocking capacitor dc--8 GHz)
<u>Connector Type</u>	
RF Port	Waveguide WR28
LO Port	MPC2 (male)
IF Port	SMA (female)
<u>Power Supply Requirements</u>	
Normal operation:	+15 $\pm$ 5% volts at 1.5 mA -15 $\pm$ 5% volts at 1.5 mA
Absolute maximum:	+25 volts

b. Connectors

RF Connector--The RF input is in waveguide WR28 mating with Flange UG(599)/U and 4-40 screw holes.

LO Connector--The LO input is designed for connecting directly to 0.085-inch semirigid coaxial cable so that the mixer can be easily integrated with a YIG-tuned local oscillator. For testing purposes, the coaxial cable has been fitted with a type MPC2 male connector (Maury Microwave Corporation) and mates with the waveguide to female MPC2 coax adapter Model. No. SR8012A from Maury Microwave Corporation.

IF Connectors--The IF port connector is a female SMA type.

c. Mounting

The mixer may be mounted in any position by means of 4-40 screws and two tapped holes in the bottom of the mixer box.

2. Environmental Limits

The following limits should not be exceeded:

- Maximum storage temperature      80°C
- Minimum storage temperature      -20°C

3. Power-Supply Requirements

For optimized performance, each of the two mixer diodes requires approximately 1.5 mA forward bias. Bias currents must be supplied from two external 15-Vdc power supplies. The +15 volts are applied to power connector FL1, and the -15 volts to power connector FL2, both with respect to frame ground. For connector layout, see Figure C-1.

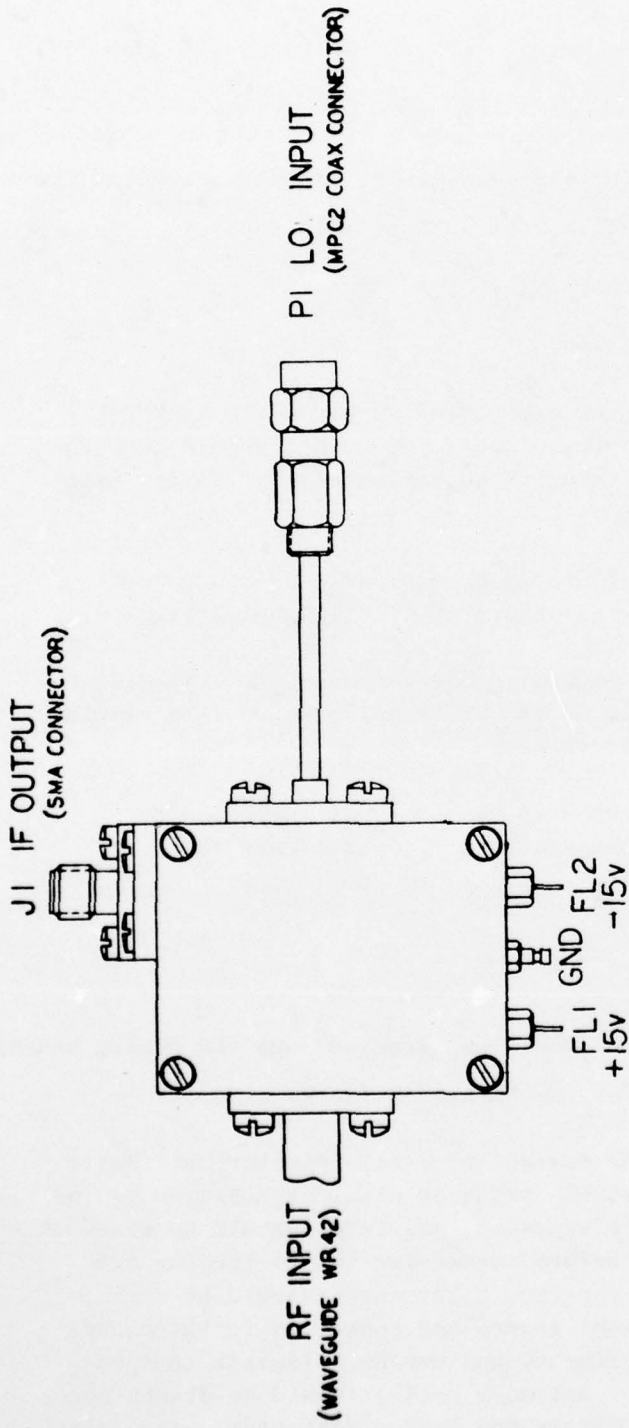

ITEM	DWG. NUMBER	DESCRIPTION	QTY.
MATL		BASIC DIMS.	DECIMAL TOL.
		UNLESS OTHERWISE SPECIFIED	FRACT. TOL.
		ANGULAR TOL.	% TO 1/8"
			% TO 1/16"
			% TO 1/32"
			% TO 3/16"
			% TO 1/4"
			% TO 3/8"
			% TO 1/2"
			% TO 5/8"
			% TO 3/4"
			% TO 7/8"
			% TO 1"
			% TO 1 1/8"
			% TO 1 1/4"
			% TO 1 3/8"
			% TO 1 1/2"
			% TO 1 3/4"
			% TO 2"
			% TO 2 1/2"
			% TO 3"
			% TO 3 1/2"
			% TO 4"
			% TO 4 1/2"
			% TO 5"
			% TO 5 1/2"
			% TO 6"
			% TO 6 1/2"
			% TO 7"
			% TO 7 1/2"
			% TO 8"
			% TO 8 1/2"
			% TO 9"
			% TO 9 1/2"
			% TO 10"
			% TO 10 1/2"
			% TO 11"
			% TO 11 1/2"
			% TO 12"
			% TO 12 1/2"
			% TO 13"
			% TO 13 1/2"
			% TO 14"
			% TO 14 1/2"
			% TO 15"
			% TO 15 1/2"
			% TO 16"
			% TO 16 1/2"
			% TO 17"
			% TO 17 1/2"
			% TO 18"
			% TO 18 1/2"
			% TO 19"
			% TO 19 1/2"
			% TO 20"
			% TO 20 1/2"
			% TO 21"
			% TO 21 1/2"
			% TO 22"
			% TO 22 1/2"
			% TO 23"
			% TO 23 1/2"
			% TO 24"
			% TO 24 1/2"
			% TO 25"
			% TO 25 1/2"
			% TO 26"
			% TO 26 1/2"
			% TO 27"
			% TO 27 1/2"
			% TO 28"
			% TO 28 1/2"
			% TO 29"
			% TO 29 1/2"
			% TO 30"
			% TO 30 1/2"
			% TO 31"
			% TO 31 1/2"
			% TO 32"
			% TO 32 1/2"
			% TO 33"
			% TO 33 1/2"
			% TO 34"
			% TO 34 1/2"
			% TO 35"
			% TO 35 1/2"
			% TO 36"
			% TO 36 1/2"
			% TO 37"
			% TO 37 1/2"
			% TO 38"
			% TO 38 1/2"
			% TO 39"
			% TO 39 1/2"
			% TO 40"
			% TO 40 1/2"
			% TO 41"
			% TO 41 1/2"
			% TO 42"
			% TO 42 1/2"
			% TO 43"
			% TO 43 1/2"
			% TO 44"
			% TO 44 1/2"
			% TO 45"
			% TO 45 1/2"
			% TO 46"
			% TO 46 1/2"
			% TO 47"
			% TO 47 1/2"
			% TO 48"
			% TO 48 1/2"
			% TO 49"
			% TO 49 1/2"
			% TO 50"
			% TO 50 1/2"
			% TO 51"
			% TO 51 1/2"
			% TO 52"
			% TO 52 1/2"
			% TO 53"
			% TO 53 1/2"
			% TO 54"
			% TO 54 1/2"
			% TO 55"
			% TO 55 1/2"
			% TO 56"
			% TO 56 1/2"
			% TO 57"
			% TO 57 1/2"
			% TO 58"
			% TO 58 1/2"
			% TO 59"
			% TO 59 1/2"
			% TO 60"
			% TO 60 1/2"
			% TO 61"
			% TO 61 1/2"
			% TO 62"
			% TO 62 1/2"
			% TO 63"
			% TO 63 1/2"
			% TO 64"
			% TO 64 1/2"
			% TO 65"
			% TO 65 1/2"
			% TO 66"
			% TO 66 1/2"
			% TO 67"
			% TO 67 1/2"
			% TO 68"
			% TO 68 1/2"
			% TO 69"
			% TO 69 1/2"
			% TO 70"
			% TO 70 1/2"
			% TO 71"
			% TO 71 1/2"
			% TO 72"
			% TO 72 1/2"
			% TO 73"
			% TO 73 1/2"
			% TO 74"
			% TO 74 1/2"
			% TO 75"
			% TO 75 1/2"
			% TO 76"
			% TO 76 1/2"
			% TO 77"
			% TO 77 1/2"
			% TO 78"
			% TO 78 1/2"
			% TO 79"
			% TO 79 1/2"
			% TO 80"
			% TO 80 1/2"
			% TO 81"
			% TO 81 1/2"
			% TO 82"
			% TO 82 1/2"
			% TO 83"
			% TO 83 1/2"
			% TO 84"
			% TO 84 1/2"
			% TO 85"
			% TO 85 1/2"
			% TO 86"
			% TO 86 1/2"
			% TO 87"
			% TO 87 1/2"
			% TO 88"
			% TO 88 1/2"
			% TO 89"
			% TO 89 1/2"
			% TO 90"
			% TO 90 1/2"
			% TO 91"
			% TO 91 1/2"
			% TO 92"
			% TO 92 1/2"
			% TO 93"
			% TO 93 1/2"
			% TO 94"
			% TO 94 1/2"
			% TO 95"
			% TO 95 1/2"
			% TO 96"
			% TO 96 1/2"
			% TO 97"
			% TO 97 1/2"
			% TO 98"
			% TO 98 1/2"
			% TO 99"
			% TO 99 1/2"
			% TO 100"
			% TO 100 1/2"
			% TO 101"
			% TO 101 1/2"
			% TO 102"
			% TO 102 1/2"
			% TO 103"
			% TO 103 1/2"
			% TO 104"
			% TO 104 1/2"
			% TO 105"
			% TO 105 1/2"
			% TO 106"
			% TO 106 1/2"
			% TO 107"
			% TO 107 1/2"
			% TO 108"
			% TO 108 1/2"
			% TO 109"
			% TO 109 1/2"
			% TO 110"
			% TO 110 1/2"
			% TO 111"
			% TO 111 1/2"
			% TO 112"
			% TO 112 1/2"
			% TO 113"
			% TO 113 1/2"
			% TO 114"
			% TO 114 1/2"
			% TO 115"
			% TO 115 1/2"
			% TO 116"
			% TO 116 1/2"
			% TO 117"
			% TO 117 1/2"
			% TO 118"
			% TO 118 1/2"
			% TO 119"
			% TO 119 1/2"
			% TO 120"
			% TO 120 1/2"
			% TO 121"
			% TO 121 1/2"
			% TO 122"
			% TO 122 1/2"
			% TO 123"
			% TO 123 1/2"
			% TO 124"
			% TO 124 1/2"
			% TO 125"
			% TO 125 1/2"
			% TO 126"
			% TO 126 1/2"
			% TO 127"
			% TO 127 1/2"
			% TO 128"
			% TO 128 1/2"
			% TO 129"
			% TO 129 1/2"
			% TO 130"
			% TO 130 1/2"
			% TO 131"
			% TO 131 1/2"
			% TO 132"
			% TO 132 1/2"
			% TO 133"
			% TO 133 1/2"
			% TO 134"
			% TO 134 1/2"
			% TO 135"
			% TO 135 1/2"
			% TO 136"
			% TO 136 1/2"
			% TO 137"
			% TO 137 1/2"
			% TO 138"
			% TO 138 1/2"
			% TO 139"
			% TO 139 1/2"
			% TO 140"
			% TO 140 1/2"
			% TO 141"
			% TO 141 1/2"
			% TO 142"
			% TO 142 1/2"
			% TO 143"
			% TO 143 1/2"
			% TO 144"
			% TO 144 1/2"
			% TO 145"
			% TO 145 1/2"
			% TO 146"
			% TO 146 1/2"
			% TO 147"
			% TO 147 1/2"
			% TO 148"
			% TO 148 1/2"
			% TO 149"
			% TO 149 1/2"
			% TO 150"
			% TO 150 1/2"
			% TO 151"
			% TO 151 1/2"
			% TO 152"
			% TO 152 1/2"
			% TO 153"
			% TO 153 1/2"
			% TO 154"
			% TO 154 1/2"
			% TO 155"
			% TO 155 1/2"
			% TO 156"
			% TO 156 1/2"
			% TO 157"
			% TO 157 1/2"
			% TO 158"
			% TO 158 1/2"
			% TO 159"
			% TO 159 1/2"
			% TO 160"
			% TO 160 1/2"
			% TO 161"
			% TO 161 1/2"
			% TO 162"
			% TO 162 1/2"
			% TO 163"
			% TO 163 1/2"
			% TO 164"
			% TO 164 1/2"
			% TO 165"
			% TO 165 1/2"
			% TO 166"
			% TO 166 1/2"
			% TO 167"
			% TO 167 1/2"
			% TO 168"
			% TO 168 1/2"
			% TO 169"

Approximately 1.5 mA will be drawn from each supply when adjusted to 15 V.

#### 4. Operation

Before placing the K-band image-reject mixer into operation, review the general precautions noted in Section 5 of this appendix. Then proceed with the following steps:

- (1) Connect power supplies.
- (2) Measure currents from each power supply while increasing voltages from zero to 15 volts. Currents should increase with voltage to a value of approximately 1.5 mA for each supply.
- (3) Connect local-oscillator source of 3-to-10-dBm power output to the coaxial connector (MPC2) labeled P1.
- (4) Connect RF signal source to waveguide input. The difference between the LO and RF frequencies must be within the 30-MHz-to-2-GHz range.
- (5) Connect IF amplifier with 50-ohm input impedance or 50-ohm load as appropriate to IF output Port J1 (Figure A-1).

#### 5. Precautions

The following procedures should be noted and applied during handling, installation, and operation of the Ka-band balanced mixer:

- (1) Mixer diodes may be damaged by static discharges. While each mixer diode in the balanced mixer is buffered by resistors and heavily bypassed, all leads should be grounded to the mixer case before connecting to the feedthrough terminals. Soldering-iron power cords should be disconnected from the power source and connected to the mixer case immediately prior to and during soldering to feedthrough terminals. All coax cables should be discharged by connecting the shield and center conductors simultaneously to the mixer case prior to connection to the mixer ports.

- (2) It is recommended that the feedthrough terminals be connected by flexible wires to a solidly mounted terminal strip if frequent connection changes are contemplated. Connections can then be made at the terminal strip. Because the feedthroughs are necessarily small, they should be protected from mechanical strain or repeated flexing to prevent breaking the small center conductor.
- (3) The LO input port (P1) of the balanced mixer is fitted with a MPC2 connector. This connector does not mate properly with SMA-type connectors, although the nuts are the same. Attempts to force a mate could result in damage to the connector. The MPC2 connector is of much higher precision than the SMA type connector and is necessary at K and Ka bands in order to achieve good performance.
- (4) The LO input to the Ka-band mixer is in 0.085-inch coaxial cable for easy integration with YIG-tuned oscillators. Care should be exercised when connecting the LO input to a signal source so that the cable is not bent or placed in torsional strain. Any bends, small kinks, or twists can have degrading effects on the mixer performance.
- (5) The mixer has test points under the top cover to monitor the diode voltages. The voltages should be measured using a meter with at least 1 megohm input impedance. With full bias applied, the total voltage between the two test points should be 1.2 to 1.4 volts. The voltage of each diode to ground lies within  $\pm 2$  volts.

Appendix D

FINAL TECHNICAL PERFORMANCE MEASUREMENT  
COMPARISON FOR THE Ka-BAND BALANCED MIXER,  
MODEL RBM-1

Appendix D

FINAL TECHNICAL PERFORMANCE MEASUREMENT  
COMPARISON FOR THE Ka-BAND BALANCED MIXER,  
MODEL RBM-1

1. Introduction

Performance goals for the Ka-band, MIC, balanced mixer are as follows:\*

Input LO power level	0 dBm minimum +6 dBm maximum
LO-port VSWR	3.0:1 maximum 2.5:1 typical
RF-port VSWR	3.0:1 maximum 2.5:1 typical
IF-port VSWR	2.0:1 maximum 1.5:1 typical
Conversion loss, RF to IF (dc-to-10-GHz IF bandwidth)	9.0 dB maximum 8.0 dB typical
Noise figure (using 1.5-dB-noise-figure IF amplifier at 168 MHz; IF bandwidth is 110 MHz)	10.5 dB maximum 9.5 dB typical
LO-to-RF isolation	20.0 dB maximum 25.0 dB typical
2 x 2 balance	40.0 dB typical

Because some of the performance goals are in terms of maximum values (conversion loss, for example) and others are in terms of minimum values (2 x 2 balance, for example), the following convention is established with regard to the listed "demonstrated variance:"

---

\* From SRI Proposal ERU 73-210, Section IV-D.

- (1) For performance goals with a maximum upper bound.
  - (a) A positive (+) demonstrated variance indicates a demonstrated value greater than the maximum performance goal. The demonstrated performance does not meet the anticipated goal.
  - (b) A negative (-) demonstrated variance indicates a demonstrated value less than the maximum performance goal. The demonstrated performance meets the anticipated goal.
- (2) For performance goals with a minimum lower bound.
  - (a) A positive (+) demonstrated variance indicates a demonstrated value greater than the minimum performance goal. The demonstrated performance meets the anticipated goal.
  - (b) A negative (-) demonstrated variance indicates a demonstrated value less than the minimum performance goal. The demonstrated performance does not meet the anticipated goal.

The convention is summarized in the following tabulation:

Planned Value	Demonstrated Variance	Demonstrated Performance Relative to Goal
Max	+	Does not meet anticipated goal
	-	Does meet anticipated goal
Min	+	Does meet anticipated goal
	-	Does not meet anticipated goal

## 2. Technical Performance Measurement Comparison

The final measured performance of the Ka-band, MIC, balanced mixer (Model RBM-1) is compared to the design goals on the following log sheets. Data are included for three local-oscillator drive levels: +3, +6, and +10 dBm. The data at +3 dBm drive are presented first, followed by data at +6 and +10 dBm.

TECHNICAL PERFORMANCE MEASUREMENT COMPARISON

K<sub>a</sub>-Band Balanced Mixer

(Final Product)

RBM-1

Date: 1/21/75

LO Power = + 3 dBm.

Parameter	Planned Value	Frequency GHz.	Demonstrated Value	Demonstrated Variance
LO Port VSWR	3.0:1 max	26.5	1.8	-1.2
		28	2.6	-0.4
		29	3.0	-0.0
		30	3.0	-0.0
		31	3.0	-0.0
		32	2.0	-1.0
		33	1.4	-1.6
		34	2.0	-1.0
		35	2.8	-0.2
		36	2.6	-0.4
		37	2.1	-0.9
		38	1.3	-1.7
		39	2.0	-1.0
		40	3.0	-0.0
Tested by:			<i>WJ</i>	
Approved by:			<i>AKJ</i>	
(-) Variance indicates demonstrated value meets the anticipated goal.				

TECHNICAL PERFORMANCE MEASUREMENT COMPARISON

K -Band Balanced Mixer  
a

(Final Product)

RBM-1

Date: 1/21/75

LO Power = + 3 dBm.

Parameter	Planned Value	Frequency GHz.	Demonstrated Value	Demonstrated Variance
RF Port VSWR	3.0:1 max	26.5	1.36	-1.64
		28	1.75	-1.25
		29	1.65	-1.35
		30	1.46	-1.54
		31	1.80	-1.20
		32	1.72	-1.28
		33	1.52	-1.48
		34	1.53	-1.47
		35	1.13	-1.87
		36	1.06	-1.94
		37	1.22	-1.78
		38	1.35	-1.65
		39	1.60	-1.40
		40	1.92	-1.08
		Tested by: <i>WJG</i>		
		Approved by: <i>MS</i>		
(-) Variance indicates demonstrated value meets the anticipated goal.				

TECHNICAL PERFORMANCE MEASUREMENT COMPARISON

K<sub>a</sub>-Band Balanced Mixer

(Final Product)

RBM-1

Date: 1/22/75

LO Power = +3 dBm.

Parameter	Planned Value	Frequency GHz.	Demonstrated Value	Demonstrated Variance
IF Port VSWR	2.0:1 max	100 MHz to 2.0 GHz	1.33 MAX	-0.67
		Tested by: <i>WJG</i>		
		Approved by: <i>AKG</i>		
(-) Variance indicates demonstrated value meets the anticipated goal.				

TECHNICAL PERFORMANCE MEASUREMENT COMPARISON

K<sub>a</sub>-Band Balanced Mixer

(Final Product)

RBM-1

Date: 1/21/75

LO Power = +3 dBm.

Parameter	Planned Value	Frequency GHz.	Demonstrated Value	Demonstrated Variance
Conversion Loss	9.0 dB max	26.5	8.0	-1.0
		28	8.5	-0.5
		29	8.0	-1.0
		30	7.8	-1.2
		31	7.8	-1.2
		32	7.7	-1.3
		33	8.0	-1.0
		34	8.1	-0.9
		35	8.0	-1.0
		36	7.8	-1.2
		37	8.0	-1.0
		38	8.7	-0.3
		39	8.6	-0.4
		Noise Figure	10.5 dB max	40
39	10.0			-0.5
		Tested by:	<i>Wag</i>	
		Approved by:	<i>My</i>	
(-) Variance indicates demonstrated value meets the anticipated goal.				

TECHNICAL PERFORMANCE MEASUREMENT COMPARISON

K<sub>a</sub>-Band Balanced Mixer

(Final Product)

RBM-1

Date: 1/21/75

LO Power = +3 dBm.

Parameter	Planned Value	Frequency GHz.	Demonstrated Value	Demonstrated Variance		
LO to RF Isolation	20.0 dB min	26.5	17	-3		
		28	21	+1		
		29	31	+11		
		30	30	+10		
		31	26	+6		
		32	24	+4		
		33	36	+16		
		34	40	+20		
		35	25	+5		
		36	28	+8		
		37	26	+6		
		38	20	+0		
		39	35	+15		
		40	33	+13		
		Tested by:			<i>WJ</i>	
		Approved by:			<i>WJ</i>	

(+) Variance indicates demonstrated value meets the anticipated goal.

TECHNICAL PERFORMANCE MEASUREMENT COMPARISON

K-Band Balanced Mixer  
a

(Final Product)

RBM-1

Date: 1/22/75

LO Power = + 3 dBm.

Parameter	Planned Value	Frequency GHz.	Demonstrated Value	Demonstrated Variance
2 x 2 Spurious	35.0 dB min	26.5	45	+ 10
		28	45	+ 10
		29	43	+ 8
		30	45	+ 10
		31	46	+ 11
		32	46	+ 11
		33	42	+ 7
		34	42	+ 7
		35	41	+ 6
		36	46	+ 11
		37	43	+ 8
		38	39	+ 4
		39	42	+ 7
		40	46	+ 11
		Tested by:	<i>WJ</i>	
		Approved by:	<i>AKG</i>	
(±) Variance indicates demonstrated value meets the anticipated goal.				

TECHNICAL PERFORMANCE MEASUREMENT COMPARISON

K<sub>a</sub>-Band Balanced Mixer

(Final Product)

RBM-1

Date: 1/21/75

LO Power = +6 dBm.

Parameter	Planned Value	Frequency GHz.	Demonstrated Value	Demonstrated Variance
LO Port VSWR	3.0:1 max	26.5	1.8	-1.2
		28	2.6	-0.4
		29	3.2	+0.2
		30	3.4	+0.4
		31	3.2	+0.2
		32	2.3	-0.7
		33	1.4	-1.6
		34	1.8	-1.2
		35	2.6	-0.4
		36	2.6	-0.4
		37	2.1	-0.9
		38	1.3	-1.7
		39	2.1	-0.9
		40	3.0	-0.0
		Tested by: <i>W. J. ...</i>		
		Approved by: <i>Amg</i>		
(-) Variance indicates demonstrated value meets the anticipated goal.				

TECHNICAL PERFORMANCE MEASUREMENT COMPARISON

K<sub>a</sub>-Band Balanced Mixer

(Final Product)

RBM-1

Date: 1/21/75

LO Power = +6 dBm.

Parameter	Planned Value	Frequency GHz.	Demonstrated Value	Demonstrated Variance
RF Port VSWR	3.0:1 max	26.5	1.43	-1.57
		28	1.90	-1.10
		29	1.80	-1.20
		30	1.65	-1.35
		31	2.0	-1.0
		32	1.98	-1.02
		33	1.75	-1.25
		34	1.68	-1.32
		35	1.26	-1.74
		36	1.24	-1.76
		37	1.14	-1.86
		38	1.12	-1.88
		39	1.38	-1.62
		40	1.70	-1.30
		Tested by: <i>Wag</i>		
		Approved by: <i>Arb</i>		
(-) Variance indicates demonstrated value meets the anticipated goal.				

TECHNICAL PERFORMANCE MEASUREMENT COMPARISON

K<sub>a</sub>-Band Balanced Mixer

(Final Product)

RBM-1

Date: 1/22/75

LO Power = +6 dBm.

Parameter	Planned Value	Frequency GHz.	Demonstrated Value	Demonstrated Variance
IF Port VSWR	2.0:1 max	100 MHz to 2.0 GHz	1.27 MAX	-0.73
		Tested by:	<i>WJG</i>	
		Approved by:	<i>AKB</i>	
(-) Variance indicates demonstrated value meets the anticipated goal.				

TECHNICAL PERFORMANCE MEASUREMENT COMPARISON

K-Band Balanced Mixer

(Final Product)

RBM-1

Date: 1/21/75

LO Power = +6 dBm.

Parameter	Planned Value	Frequency GHz.	Demonstrated Value	Demonstrated Variance
Conversion Loss	9.0 dB max	26.5	7.8	-1.2
		28	8.2	-0.8
		29	7.6	-1.4
		30	7.4	-1.6
		31	7.8	-1.2
		32	7.5	-1.5
		33	7.8	-1.2
		34	7.8	-1.2
		35	7.6	-1.4
		36	7.6	-1.4
		37	7.7	-1.3
		38	7.7	-1.3
		39	7.3	-1.7
Noise Figure	10.5 dB max	40	8.2	-0.8
		39	9.1	-1.4
		Tested by:	<i>WJG</i>	
		Approved by:	<i>AKG</i>	
(→) Variance indicates demonstrated value meets the anticipated goal.				

TECHNICAL PERFORMANCE MEASUREMENT COMPARISON

K<sub>a</sub>-Band Balanced Mixer

(Final Product)

RBM-1

Date: 1/22/75

LO Power = +6 dBm.

Parameter	Planned Value	Frequency GHz.	Demonstrated Value	Demonstrated Variance
LO to RF Isolation	20.0 dB min	26.5	18	-2.0
		28	21	+1.0
		29	30	+10.0
		30	30	+10.0
		31	27	+7.0
		32	24	+6.0
		33	31	+11.0
		34	32	+12.0
		35	24	+4.0
		36	27	+7.0
		37	24	+4.0
		38	18	-2.0
		39	32	+12.0
		40	32	+12.0
				Tested by:
		Approved by:	<i>Stacy</i>	
(+) Variance indicates demonstrated value meets the anticipated goal.				

TECHNICAL PERFORMANCE MEASUREMENT COMPARISON

K<sub>a</sub>-Band Balanced Mixer

(Final Product)

RBM-1

Date: 1/22/75

LO Power = +6 dBm.

Parameter	Planned Value	Frequency GHz.	Demonstrated Value	Demonstrated Variance
2 x 2 Spurious	35.0 dB min	26.5	45	+10
		28	49	+14
		29	43	+8
		30	45	+10
		31	46	+11
		32	46	+11
		33	42	+7
		34	42	+7
		35	43	+8
		36	47	+12
		37	46	+11
		38	45	+10
		39	46	+11
40	45	+10		
		Tested by:	<i>WJ</i>	
		Approved by:	<i>WJ</i>	
(+) Variance indicates demonstrated value meets the anticipated goal.				

TECHNICAL PERFORMANCE MEASUREMENT COMPARISON

K-Band Balanced Mixer  
a

(Final Product)

RBM-1

Date: 1/22/75

LO Power = +10 dBm.

Parameter	Planned Value	Frequency GHz.	Demonstrated Value	Demonstrated Variance
LO Port VSWR	3.0:1 max	26.5	2.0	-1.0
		28	2.5	-0.5
		29	3.4	+0.4
		30	3.3	+0.3
		31	3.4	+0.4
		32	2.2	-0.8
		33	1.8	-1.2
		34	2.1	-0.9
		35	2.6	-0.4
		36	2.6	-0.4
		37	2.3	-0.7
		38	1.25	-1.75
		39	2.3	-0.7
		40	3.0	-0.0
		Tested by:	<i>Waz</i>	
		Approved by:	<i>AKG</i>	
(→) Variance indicates demonstrated value meets the anticipated goal.				

TECHNICAL PERFORMANCE MEASUREMENT COMPARISON

K-Band Balanced Mixer  
a

(Final Product)

RBM-1

Date: 1/21/75

LO Power = +10 dBm.

Parameter	Planned Value	Frequency GHz.	Demonstrated Value	Demonstrated Variance
RF Port VSWR	3.0:1 max	26.5	1.53	-1.47
		28	2.1	-0.9
		29	2.0	-1.0
		30	1.98	-1.02
		31	2.3	-0.7
		32	2.3	-0.7
		33	2.05	-0.95
		34	1.88	-1.12
		35	1.45	-1.55
		36	1.50	-1.50
		37	1.30	-1.70
		38	1.12	-1.88
		39	1.22	-1.78
		40	1.53	-1.47
		Tested by:	<i>WJ</i>	
		Approved by:	<i>ATG</i>	
(-) Variance indicates demonstrated value meets the anticipated goal.				

TECHNICAL PERFORMANCE MEASUREMENT COMPARISON

K<sub>a</sub>-Band Balanced Mixer

(Final Product)

RBM-1

Date: 1/22/75

LO Power = +10 dBm.

Parameter	Planned Value	Frequency GHz.	Demonstrated Value	Demonstrated Variance
IF Port VSWR	2.0:1 max	100 MHz to 2.0 GHz	1.5 MAX	-0.5
		Tested by:	<i>WJ</i>	
		Approved by:	<i>MS</i>	
(→) Variance indicates demonstrated value meets the anticipated goal.				

TECHNICAL PERFORMANCE MEASUREMENT COMPARISON

K<sub>a</sub>-Band Balanced Mixer

(Final Product)

RBM-1

Date: 1/21/75

LO Power = +10 dBm.

Parameter	Planned Value	Frequency GHz.	Demonstrated Value	Demonstrated Variance
Conversion Loss	9.0 dB max	26.5	8.0	-1.0
		28	8.3	-0.7
		29	7.4	-1.6
		30	7.2	-1.8
		31	7.8	-1.2
		32	7.5	-1.5
		33	7.9	-1.1
		34	8.0	-1.0
		35	7.4	-1.6
		36	7.6	-1.4
		37	7.6	-1.4
		38	7.4	-1.6
		39	6.7	-2.3
		40	7.6	-1.4
Noise Figure	10.5 dB max	39	8.6	-1.9
		Tested by: <i>WJF</i>		
		Approved by: <i>Akey</i>		
(→) Variance indicates demonstrated value meets the anticipated goal.				

TECHNICAL PERFORMANCE MEASUREMENT COMPARISON

K<sub>a</sub>-Band Balanced Mixer

(Final Product)

RBM-1

Date: 1/22/75

LO Power = +10 dBm.

Parameter	Planned Value	Frequency GHz.	Demonstrated Value	Demonstrated Variance
LO to RF Isolation	20.0 dB min	26.5	17	-3
		28	22	+2
		29	30	+10
		30	30	+10
		31	26	+6
		32	25	+5
		33	30	+10
		34	33	+13
		35	23	+3
		36	27	+7
		37	24	+4
		38	18	-2
		39	32	+12
		40	32	+12
		Tested by:	<i>usgi</i>	
		Approved by:	<i>Andy</i>	
<p>(+) Variance indicates demonstrated value meets the anticipated goal.</p>				

TECHNICAL PERFORMANCE MEASUREMENT COMPARISON

K-Band Balanced Mixer  
a  
 (Final Product)

RBM-1

Date: 1/22/75

LO Power = +10 dBm.

Parameter	Planned Value	Frequency GHz.	Demonstrated Value	Demonstrated Variance
2 x 2 Spurious	35.0 dB min	26.5	45	+10
		28	53	+18
		29	43	+8
		30	45	+10
		31	46	+11
		32	46	+11
		33	43	+8
		34	43	+8
		35	43	+8
		36	47	+12
		37	46	+11
		38	48	+13
		39	47	+12
		40	45	+10
Tested by:			<i>WJG</i>	
Approved by:			<i>WJ</i>	
(*) Variance indicates demonstrated value meets the anticipated goal.				