

AD-A039 039

NAVAL INTELLIGENCE SUPPORT CENTER WASHINGTON D C TRA--ETC F/G 11/6
SAFETY ORDERS AND INDUSTRIAL SANITATION DURING MECHANICAL TREAT--ETC(U)
FEB 77 L P SHARIKOV

UNCLASSIFIED

NISC-TRANS-3913

NL

| OF |
AD
A039039



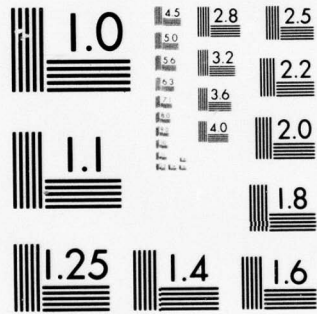

MICROCOPY RESOLUTION TEST CHART
NATIONAL BUREAU OF STANDARDS-1963-A



DEPARTMENT OF THE NAVY
 NAVAL INTELLIGENCE SUPPORT CENTER ✓
 TRANSLATION DIVISION
 4301 SUITLAND ROAD
 WASHINGTON, D.C. 20390

3
 NW

ADA 039039

CLASSIFICATION: UNCLASSIFIED

TITLE:

6 Safety Orders and Industrial Sanitation during
 Mechanical Treatment and Use of Aluminum and
 Titanium Alloys

(Pravila Tekhniki Bezopasnosti i Proizvodstvennoy
 Sanitarii Pri Obrabotke i Primenenii Alyumin'yevykh
 i Titanovykh Splavov)

37 AUTHOR(S): L.P. Sharikov, L.P., Editor

PAGES: 36

SOURCE: Spravochnik po okhrane truda. Normy i pravila po
 metallo-i derevoobrabotke
 Vol. 3, Sudostroyeniye Publ. House, Leningrad, 1973,
 pp. 172-181, 238-260.

ORIGINAL LANGUAGE: Russian

DISTRIBUTION STATEMENT A

Approved for public release,
 Distribution Unlimited

TRANSLATOR: C

407 682
 DDC
 RECEIVED
 MAY 4 1977
 A

14 NISC-TRANSLATION NO. 3913 ✓

AJ No.
 DDC FILE COPY

APPROVED P.T.K.

DATE 17 February 1977

ACQUISITION NO.	
NTIS	White Section
DDC	Buff Section <input type="checkbox"/>
UNANNOUNCED	<input type="checkbox"/>
JUSTIFICATION	
BY	
DISTRIBUTION AVAILABILITY CODES	
Dist.	Avail. and/or SPECIAL
A	

12 37p.

lpg

SAFETY ORDERS AND INDUSTRIAL SANITATION DURING MECHANICAL TREATMENT AND USE OF ALUMINUM AND TITANIUM ALLOYS

[Sharikov, L. P., Editor, Spravochnik po okhrane truda. Normy i pravila po metallo- i derevoobrabotke (Labor Safety Manual. Standards and Rules on Maching of Metals and Wood), Vol. 3, Sudostroyeniye Publ. House, Leningrad, 1973, pp. 172-181, 238-260]

General Orders For Machining Operations

/172*

1. Metal working machines and equipment their arrangement and location shall comply with the Safety Orders and Industrial Sanitation for Cold Working of Metals in Machine-Building Industry and with these Orders.

2. Industrial instructions for cutting alloys shall include all requirements for safety operation of the machinery.

3. Water-based emulsions containing mineral and plant oils, as well as their mixtures shall be used as cooling agents during cutting of alloys.

Cooling emulsions containing 80% of sulfofrezol, up to 15% of kerosene and up to 5% of oleic acid shall be used for cooling purposes during drilling and deep boring of metal parts.

Binding-cooling emulsions shall be prepared for the entire plant according to formula approved by the chief engineer and verified by laboratory analysis.

Cooling emulsions shall be filtered in the course of their circulation for the removal of chips, dirt and filings. Emulsions shall be checked at least once a week for the presence of microbes capable of producing skin diseases.

→ 4. The geometry of cutters, turning conditions and cooling of metal bars shall secure a proper heat dissipation from the cutting zone. The temperature of chips shall not exceed 150-200°C. To eliminate ignition of chips, metal bars shall be fed with a speed not exceeding 0.06 mm

* Numbers in the right-hand margin indicate pagination in the original text

per revolution, or with the cutting rate of not more than 100 m/min.

5. A local exhaust shall be installed for the removal of dust, small metal chips and filings. /172

6. Air exhaust ducts shall have:

(a) Smooth internal surfaces, without any pockets and recesses in which dust could be accumulated;

(b) short, with a minimum number of turns; a radius of each turn shall not be less than three diameters of the air duct.

Heating, Heat Treatment and Surface Cleaning of Metals

7. Loading, unloading and turning of metal pieces in heat-treating units shall be mechanized. /173

8. Heating units shall be equipped with temperature controlling gages. Increase in the heating temperature above that indicated in instructions shall be forbidden because of a possible ignition of titanium.

9. Heated titanium alloys shall not be brought in contact with iron scale during heat treatment in furnaces, salt baths and alkali-acid etching.

Heat-treatment units designed for titanium alloys shall not be used for steels. In cases when it ^{is} unavoidable, the heating units must be carefully cleaned of scale and slag after each use.

10. Furnaces and baths for heating and chemico-thermal treatment of alloys shall be equipped with emergency turning-off devices. The use of potassium baths shall be forbidden.

11. Etching compounds shall be prepared according to formula supplied by the plant central laboratory and approved by the Division of Industrial Safety.

12. Baths shall be provided with enclosures and good ventilation. Ordinary exhaust on both sides of each bath shall be used. Enclosures over baths shall have opening on top not exceeding 0.9 m for baths wider than 1 m. Table 1 shall be used for determining the volume (m^3/hr) of the exhaust air from each baths.

13. Degreasing the steel metal and parts with organic solvents shall be conducted only in the presence of good exhaust ventilation. Regardless of ventilation, employees doing the degreasing work must wear filtering

Table 1.

/174

Bath length m	Exhaust air (m ³ /hr)									
	single duct exhaust					double duct exhaust				
	bath width, m									
	0,5	0,6	0,7	0,8	0,6	0,8	1,0	1,2	1,4	1,6
0,6	700	950	—	—	750	—	—	—	—	—
0,8	875	1100	1375	1600	900	1300	—	—	—	—
1,0	1000	1300	1550	1850	1100	1500	2000	—	—	—
1,2	1150	1500	1750	2100	1250	1800	2300	2800	—	—
1,5	1375	1750	2125	2500	1300	2200	2800	3500	4300	—
1,8	1625	2000	2450	2875	1800	2500	3300	4100	4900	5700
2,0	1750	2250	2700	3100	2100	3000	3800	4600	5400	6200
2,5	2200	2750	3250	3800	2400	3400	4500	5500	6500	7500
3,0	2550	3250	3900	4500	2900	4100	5300	6500	7700	8800
3,5	3000	3700	4375	5000	3400	4700	6000	7400	8800	10100
4,0	3375	4200	4950	5700	3800	5200	6800	8800	9800	11300
4,5	3750	4600	5450	6300	4200	5800	7600	9200	11000	12600
5,0	4250	5100	5900	6750	4600	6400	8400	10200	12000	14000
5,5	4500	5500	6450	7300	5000	7000	9100	11100	13100	15100
6,0	4950	5950	7000	8200	5500	7600	9800	12000	14200	16500

Note. The air speed over the bath solution surface is accepted to be $v_k = 0.2$ m/sec.

When $v_k = 0.25, 0.3$ and 0.4 m/sec, the volume of exhaust air obtained from this Table is multiplied by 1.25, 1.5 and 2.0, respectively.

If the bath longitudinal side is located along a wall, the air volume is reduced by 15% for a single duct exhaust and by 10% for double duct exhaust.

respirators (RU-60 or F-46K) or gas masks.

/173

14. Baths for alkali oxidation shall be well thermoinsulated. Loading and unloading of baths shall be mechanized. Design, location and height of bath shall secure convenience and work safety.

15. The level of oxidizing solutions in each bath shall not be less than 30 mm below the bath edge.

16. Special implements (pipes reaching to a bath bottom for supplying hot water, perforated buckets for alkali solution, dippers with long handles, etc.) shall be used for correcting the solution composition and for the solution splashing prevention.

17. Only trained employees equipped with special plexiglass masks or eye protection glasses shall be allowed to work with oxidation baths.

18. The use of the plant gas pipe system for shielding gases shall be approved by the pipe service man upon presenting an identification counter by a welder. Shielding gases shall be passed through a reductor and rotometer.

/175

Counters for shielding gases shall be issued to welders daily by a shop forman who is responsible for industrial safety in his shop.

19. Upon receiving the counter, the gas pipe service man connects a gas hose, provided the latter is undamaged.

20. Plant administration personnel shall check at least once a week the oxygen concentration at the floor level in each welding shop using shielding gases for welding.

21. When welding is carried out in not easily accessible spaces visible signs shall be placed at the entrance to these spaces.

WELDING AND CUTTING OF ALLOYS

22. Welding with application of degreasing solvents can be conducted only with the permission of Fire Department and the person in charge of a given shop.

All welding areas shall be equipped with fire extinguishers.

23. The following rules shall be followed during degreasing the metal edges to be welded:

(a) Each welder is supplied with an unbreakable 200 g container filled with acetone and with a dispersing rubber bulb to wet wads (ethyl

alcohol can be used in confined spaces);

/175

(b) Spilled solvent shall immediately^{be} removed with wads;

(c) Wet wads^{shall} be placed in a special container filled with water (50%) and equipped with a cover; it is forbidden to dispose of wads in any other manner.

(d) Pieces can be welded only after the removal of solvents from them and of wet wads;

(e) Containers with acetone must be kept in a separate room. They must be under supervision of a responsible person.

24. Gas-cutting, gas-welding and gas-flame treatment operations shall be conducted according to the Safety Orders and Industrial Sanitation Rules^{for} the Production of Acetylene, Oxygen and Gas-Flame Treatment of Metals.

25. Electric welding and gas-electric cutting shall correspond to requirements of the Safety Orders and Industrial Sanitation Rules for Electric Arc Welding.

26. Harmful gases and dust shall be eliminated from work areas (welding and cutting) by a local ventilation. Confined spaces (sections, tanks, enclosures, etc.) shall have at least two temporary scuttles, one for communication lines and the second for the emergency evacuation of employees.

/176

Cutting and welding of metals shall be carried out only in the presence of a local exhaust ventilation.

27. Special exhaust hoods (of Chernoberezhskiy or Karacharov type) located over work areas shall be used during manual electric-arc welding.

28. Either single or double -duct hoods installed on a movable base shall be used during welding of large pieces outside of the welder's cabin.

29. Ventilation of ship sections can be accomplished by exhausting the air from the upper zone. Welding in argon requires an additional exhaust duct located in the lower part of a section. This is excluded in the case of helium. Centrifugal ventilators of high pressure or multistage centrifugal machines can be used for exhaust systems.

30. The exhaust air shall be directed to the exterior of the building.

If a shop is equipped with a general ventilation, the exhaust air from confined spaces can be ^{fed} into it, provided the concentration level of harmful substances is low.

31. Manual gas-cutting and air-arc planing at undesignated work areas, both in shops and in ship sections, can be carried out in the presence of a general ventilation, provided each welder uses individual protection means of respiratory tract (REGS respirator or hose devices supplying fresh air). Without individual protection of respiratory organs, no other works shall be performed within 5 m radius from the welding area.

32. Before welding containers (tanks, vessels, etc.), they shall be carefully cleaned, dried, ventilated and the air in them must be analyzed. Welding of these containers shall be carried out with open scuttles, special openings and effective ventilation.

33. When welding and gas-cutting inside of confined containers is carried out, an employee with special instructions should stand-by to help in the case of emergency.

34. In order to completely evacuate harmful vapors and gases from a welded container, the volume of air in it shall be replaced at least 30 times .

Special Requirements When Handling the Titanium Alloys

35. General ventilation shall be used during the argon-arc welding of titanium alloys with tungsten electrodes. During the semi-automatic welding with consumable electrodes, welders must be supplied with fresh air by means of masks or use filtering respirators of REGS type in addition to the general ventilation. A local exhaust of gases and dust formed under a layer of flux must be provided during automatic welding of alloys with consumable and nonconsumable electrodes in shielding gases. Dust and gases formed during gas-cutting on special benches shall be removed by exhaust ducts located in lower bench sections.

36. Automatic welding machines shall be provided with built-in traps for gas and dust.

37. Titanium dust formed during polishing operations shall be removed when wet and dried at a designated place.

38. Bottom plates, equipment and auxiliary devices shall be regularly cleaned of scale, in order to eliminate self-ignition. /177

39. Bottom plates used for heating the titanium alloys shall be made of ceramic materials which are resistant to oxidation.

40. Metal pieces in heating furnaces shall be moved smoothly, without sharp impacts.

41. Titanium and its alloys shall be prevented for contacting fuming nitric acid.

Collection and Storage of Waste

42. Filings, chips and other waste of titanium alloys shall be collected into special containers carrying the sign "Titanium waste".

43. Dust, filings and small chips shall be stored in a special dry room (fireproof of third degree), with a reliable continuous ventilation. Storage of titanium filings in open containers and under open skies shall be forbidden.

44. Flammable compounds, chemicals and cleaning fluids shall not be stored together with titanium waste.

45. Dust traps and exhaust ducts shall be cleaned at least once a day.

46. Oily small chips and filings of titanium alloys shall be collected into hermetically sealed containers and burned, or buried at designated places.

47. No accumulation of dust on wall and equipment shall be permitted in shops processing titanium alloys. A daily wet cleaning shall be carried out of all work areas.

Prevention and Extinguishing of Fires

48. Shops designated for the treatment of titanium alloys shall satisfy "The Fire Safety Requirements. Basic Rules" (SNiP II-A, 5 - 62). (Presently in force is "Fire Safety Rules for Designing Shops and Buildings", SNiP II-A. 5-70). /178

49. Storage of flammable materials in work areas processing titanium alloys is forbidden.

50. Strict safety rules shall be imposed in shops machining titanium

alloys. Titanium alloy chips shall be sorted and stored separately according to each alloy in special metal boxes located in fire-proof places.

/178

No other metals, oily rags or flammable materials shall be stored in the same boxes.

The total amount of chips shall not exceed 30 kg per shift in any particular shop. After each shift the chips shall be delivered to a responsible person at the place of their storage.

51. Large titanium chips and other waste of titanium alloys shall be stored at designated places (under shed or hangars) and shall be arranged in piles:

(a) small waste in piles 0.7 x 3 x 5 m; distances between piles shall be 1.5-2.0 m;

(b) large waste in piles not exceeding 1.5 m in height and 1.5 x 2 m in size; distances between piles shall be 2-2.5 m.

Chips packed in boxes shall be arranged in 3 m high stocks by 3 x 5 m in size; distances between stocks shall be at least 2.5 m.

The fire safety zones between the storage places of titanium chips and other building shall be at least 50 m.

52. Storage places of titanium chips and boxes containing chips shall be under constant supervision with respect to fire safety. These places shall be provided with a dry quartz sand, or magnesium oxide powder (two volumes of powder per volume of chips), shovels, scoops, gaffs and other fire equipment. All these fire implements shall easily be accessible.

53. Neither water, nor foam fire extinguishers shall be used for burning chips because of possible explosions due to the hydrogen evolution in the course of water decomposition.

54. Burning titanium can be extinguished with dry sand, dolomite powder, powdered flux, manual and transportable extinguishers charged with dry powdery substances.

55. Accumulation of large amount of titanium chips and other titanium waste shall be forbidden. Compacted waste shall be disposed off according to industrial safety rules.

56. Fire safety departments shall enforce fire safety rules with respect to handling and treatment of titanium alloys in shops and laboratories.

57. Fire accesses to any building or storage place shall be kept free of obstacles.

/178

58. Pipes carrying liquid and gaseous fuel shall be equipped with turning-off valves and located in easily-accessible places.

All pipes and other fuel-carrying equipment shall be periodically checked and maintained in proper order.

59. Containers with flammable fluids shall be equipped with covers and with devices eliminating overfills.

/179

60. Exhaust ventilation units for titanium dust shall not be connected with another exhaust system.

61. Use of open flame, electric or gas welding and cutting at temporary work places can be permitted only under supervision by a fire safety personnel. Surfaces on which open flame would be used shall be carefully cleaned of titanium dust and dirt.

62. Wiping material shall be stored in metal containers and disposed off outside of the shop at least once a day.

Special Requirements When Handling Aluminum Alloys

63. The concentration limit of aluminum dust (all types of alloys) is 2 mg/m^3 of air.

64. All stationary work areas for argon-arc welding with tungsten electrodes shall be equipped with a local exhaust system for dust and gases. A general ventilation shall be sufficient for occasional welding in temporary areas.

65. Local exhaust systems for dust and gases shall be installed for automatic welding of Al alloys with consumable electrodes in shielding gases, and general ventilation for semi-automatic welding, provided each welder is equipped with individual protection of the respiratory tract.

66. Welding tasks in shielding gases shall be carried out only in the presence of local ventilation, with consideration of physical properties of each gas used for shielding. When argon is used, which is heavier than air, the exhaust ducts shall be installed at the top (for light gases and dust) and at the bottom (for the removal of used argon) of the shop.

67. The laying-out benches for gas-electric cutting of sheet metal shall be equipped with built-in exhaust ducts at the bottom.

Individual Protective Devices

/179

68. Individual protective devices shall be used in those cases when the available ventilation system does not secure a proper elimination of gases and dust from the welder's breathing zone.

69. Valveless respirators ShB-1 "Lepestok" is recommended when welding, cutting and planing in shops and in open areas where the concentration of ozone and nitrogen oxides does not exceed the allowable levels.

70. Individual devices with a fresh air supply shall be used in confined places.

To these type of devices belong the gas mask PSh-2, respirator DPA-5 and respirator ASM with automatic control.

71. The air used for breathing devices shall not contain water droplets, oil, dust, vapors of hydrocarbons and carbon monoxide.

/180

72. Half-masks PM-2 or KSM-2 are recommended when face shields are used during welding.

73. Filtering REGS respirator can be used for protection against welding dust and gases.

74. Eyes shall be protected with protective light filters according to requirements presented in "Glass light filters for protection of eyes against harmful industrial radiation" (GOST 9497 - 60).

Light filters shall selected according to the light brightness (Table 2).

Table 2.

Purpose of light filters	Type of filters	Current, A	Classification number of filters
For electric welders	E-1	30-75	9
	E-2	75-200	10
	E-3	200-400	11
	E-4	above 400	12
For auxiliary personnel	V-1	-	2.4
	V-2	-	3
	V-4	-	4
For gas welders and gas cutters	G-1	-	4
	G-2	-	5
	G-3	-	6

75. Special work clothes and footwear shall be issued according to /180
"Standards and Rules for Free Work Clothes, Footwear and Protective
Devices for Workers and Employees of Machine-building and Metal-Working
Industries".

Responsibilities of Administrative Personnel

76. All administrative and engineering personnel of plants and organizations dealing directly with the machining and use of aluminum and titanium alloys must study these rules and to enforce them in the course of their duties.

77. Administrative personnel of plants, organizations and shops where alloys are subjected to machining or other treatment must study these rules and explain them to workers, emphasizing the safety requirements for industrial processes employed at a given plant. All instruction approved by the chief engineer shall be issued to each worker upon signing for it.

78. Administration of a plant or organization shall:

/181

(a) not allow employees to work without approved instructions and other industrial documents containing the safety techniques;

(b) not allow young (below 18 years) employees to carry out work assignment without instructing them in industrial and fire safety rules;

(c) secure a daily control for the fulfillment of these requirements with respect to industrial safety.

79. Administration shall periodically test employees in the knowledge of safety rules. Results of these tests shall be recorded.

Conclusion

80. (omitted)

81. Administration of plants, departments heads and formans are responsible for following these rules by employees.

82. Violators of these rules will be made answerable before appropriate authority.

SAFETY ORDERS AND INDUSTRIAL SANITATION FOR ELECTRIC
WELDING IN SHIELDING GASES.

(Approved by the Central Committee Presidium of Labor Union of the Ship-Building Industry on May 20, 1970)

/238

1. General Provisions

1.1. These orders are for plants and organizations belonging to Labor Union of Ship-building Industry. They include basic requirements regarding the safety and industrial sanitation encountered during designing, building and repairing ships, equipment and machine parts, as applicable to welding in shielding gases. These orders are in addition to the following existing orders:

/239

General Safety Orders and Industrial Sanitation for Plants and Organizations of Machine-building Industry (Approved by the Central Committee Presidium of Labor Union of Machine-Building on Sept. 29, 1958).

Labor Safety and Industrial Sanitation for Electric Welding (Approved by the Central Committee Presidium of the Machine-Building Union on January 8, 1960).

Labor Safety and Industrial Sanitation During Treatment and Use of Aluminum and Titanium Alloys (Approved by the Central Committee Presidium of the Labor Union of Ship-Building Industry on June 23, 1966).

Labor Safety and Industrial Sanitation for Ship-Building and Ship-Repairing Tasks (Approved by the Central Committee Presidium of the Ship-Building Labor Union on March 25, 1970).

1.2. Present Orders are in effect since January 1, 1971.

1.3. These orders are compulsory for
employees designing weld structures and industrial processes for new ships and those under repair, including machine parts and instruments;
employees dealing with planning and operating of assembly-welding shops and sections;
employees designing devices for welding in shielding gases;
engineers and technicians who are in charge of assembly-welding operations, with the use of welding in shielding gases.

1.4. Administrative personnel of plants, organizations and shops /239
shall develop appropriate labor safety instructions on the basis of these Orders. Labor safety instructions shall be issued to each employee on their signatures after approval of the chief engineer.

1.5. Administrative and engineering personnel of plants and organizations dealing directly with welding in shielding gases shall study these Orders, pass tests and use them in their daily activities.

1.6. All electric welders shall be tested on labor safety techniques at least once a year by administrative personnel. Test results shall be recorded and kept for references.

1.7. Only those workers shall be allowed to weld in shielding gases who passed a special medical examination according to guide rules issued by the Ministry of Health of the USSR on May 30, 1969. These examinations shall be periodical.

1.8. Women shall not be allowed to perform welding tasks in confined and not easily accessible spaces.

2. Main Harmful Effects of Industrial Processes /240 and Sanitary Requirements Toward Air in Industrial Shops

2.1. Properties of such shielding gases as argon, helium, nitrogen and carbon monoxide shall be studied in advance before the setting up welding operations in shielding gases.

Properties of these gases are presented in Appendix 1.

2.2. Welding in shielding gases is accompanied by dust, gases, molten metal droplets and ultraviolet radiation, the intensity of which is 5-20 times higher in comparison with a manual electric-arc welding with coated electrodes.

The amount of harmful substances produced during welding depends on the type of welding and materials (see Appendix 2).

2.3. A considerable amount of thermal radiation is produced during welding. The intensity of this radiation is presented in Appendix 3. When welding in CO_2 with the thermal radiation exceeding 3 cal/cm^2 , all burner handles shall be equipped with protective shields for hands.

2.4. Sanitary conditions at work places in shops and at individual areas shall follow requirements presented in SN 245 - 63 (Presently in effect is SN 245 - 71 "Sanitary Standards for Designing Industrial Plants", Vol. 1, p. 61). /240

2.5. The concentration of oxygen in welding shop shall be at least 19% (with respect to volume).

2.6. The air in industrial plants shall be systematically analyzed at least twice a year (during cold and hot seasons). Analyses shall be conducted every time another type of welding is used and when the amount of welding load in a given shop increases significantly. The labor safety personnel have rights to request for the air analysis in any of the shops.

2.7. When welding is carrying out in confined places or not easily accessible spaces the concentration of oxygen in these places shall be checked continuously. This can be accomplished with automatic gas analyzer of a continuous action.

When carbon dioxide is used for welding in confined spaces, the air in these rooms shall be tested not only for oxygen but also for CO and CO₂ several times per shift with portable automatic gas analyzers. Types of air analyzers are shown in Appendix 4.

Note. To confined rooms belong ship cabins with several small opening which prevent a natural air circulation . To these rooms belong ship sections, tanks, cofferdams, bottom spaces, etc. The not easily accessible ^{spaces} on ships are rooms of very small size in which it is difficult to work and where the natural air circulation is insufficient. All works in confined spaces on new ships and those being repaired shall be carried out with the use of automatic air analyzers. A list of such spaces is prepared for each ship and is approved by the labor safety section, union representative and chief engineer.

3. General Safety Requirements

/241

3.1. Dust and gases formed during welding in shielding gases shall be eliminated by exhaust ventilation directly from work areas. In addition to a local ventilation, a general air-circulating ventilation shall be provided.

3.2. In those case when it is impossible to eliminate harmful substances by ventilation, welders shall be provided with individual protective means.

3.3. Welding in shielding gases in confined and not easily accessible spaces shall be carried out when the following conditions are fulfilled: /241

(a) to have at least two temporary hatches, one for communication means and another for emergency exits;

(b) a presence of a continuous ventilation supplying enough oxygen and evacuating harmful substances;

(c) a presence of observers who checks the ventilation and welders, with some training in the first aid;

(d) a special permission to work with open flame;

(e) a presence of an automatic shut off device in the gas line when welding must stop. The use of devices equipped with burner valves is permitted for a fast turning off the shielding gas.

(f) a presence of a turning off valve in a device blowing the protective gas.

3.4. Confined and not easily accessible^{ble} spaces shall be well ventilated before and after welding operations:

(a) for 15-20 min before work and checking the air with the air analyzer:

(b) after work for a complete removal of harmful gases and dust.

3.5. Gas hoses shall be carefully checked for holes and at joints before being used in confined spaces.

3.6. When large amount of harmful gases and dust is produced in the presence of intensive thermal radiation, the welding in confined and not easily accessible spaces shall be forbidden under accelerated welding conditions (diam of electrodes > 1.2 mm; $I_w > 250$ A).

3.7. During rewelding of temporary opening for ventilation in confined or not easily accessible spaces, fresh air must be supplied to the welder's breathing zone, in addition to requirements presented under 3.3, 3.4, 3.5, /242 3.6 and 3.9 of present Orders.

3.8. When welding^{the} pipe lines in confined or not easily accessible spaces, the shielding gas supplied into pipes shall also be used for shielding the external weld, or it must be completely evacuated with a special hose to the exterior of the ship.

Neither blowing, nor shielding gases from the pipe line being welded are allowed to be accumulated in work shops.

3.9. Welding in confined and not easily accessible spaces in argon or carbon dioxide in lying position shall be allowed, provided a fresh air is supplied to the welder's breathing zone and the air is analyzed at the lowest point of the work area.

3.10. Instructions for electric welding in shielding gases in confined and not easily accessible spaces shall list the safety measures and the number of welders that can work simultaneously in these spaces.

3.11. When welding in argon and carbon dioxide, all openings, hatches and small holes shall be plugged, in order to prevent these gases to enter other rooms.

In those cases when it is impossible to seal adjacent rooms, they must be ventilated and be empty according to Orders 3.3a. The same requirements apply to areaways, ducts, wells and other rooms located next to areas where welding in argon or carbon dioxide is carried out.

3.12. Degreasing of edges for welding shall be accomplished, as a rule, with harmless water solutions. The use of acetone, white alcohol and ethyl alcohol is allowed only in exceptional cases when welding is performed in open areas; ethyl alcohol can be used when welding in confined spaces.

3.13. Organic solvents (acetone, white alcohol and ethyl alcohol) shall be distributed in 200 g nonbreakable containers by a person responsible for given assignments.

3.14. Wet used wads shall be collected into special containers made of noncombustible material and equipped with covers. These containers shall be emptied at least twice per shift.

3.15. Edges and weld sections heated above 50°C shall not be wiped with organic solvents.

3.16. Containers with organic solvents shall be stored in special rooms.

3.17. Distribution and collection of unused solvents shall be conducted by authorized personnel.

3.18. Welding areas of lined or coated pieces shall be cleaned of combustible materials at a distance of 100 mm on each side of the weld. Coatings shall be removed on both sides.

3.19. Welding areas of pieces coated with paste, glue, sealing com-

pounds, etc. shall be cleaned according to industrial requirements.

/243

3.20. Welding of faced pieces is conducted according to the fire safety requirements.

3.21. Welding shall be forbidden to be conducted simultaneously with painting, facing, insulating and unsealing operations because of the use of easily flammable materials.

3.22. Welding in rooms where painting, insulating and facing works are performed shall be allowed only after these room are thoroughly ventilated and the air is analyzed for the presence of harmful vapors and gases.

3.23. In order to protect other workers from electric arc radiation, all work areas shall be shielded.

3.24. Welding enclosures and portable shields shall be painted with dark paint based on zinc oxide, in order to reduce ultraviolet reflection and decrease the ozone formation.

3.25. Arc-welding machine for welding in carbon dioxide shall be equipped with built-in suction units.

3.26. Use of thoriated tungsten electrodes for welding in shielding gases shall be forbidden.

4. Requirements Ventilation and Heating

4.1. Industrial shops designated for welding works shall be equipped with ventilation and heating system according to requirements presented in Sanitation Standards for Designing Industrial Plants (SN 245 - 71, Vol. 1, p. 61), Sanitation Orders for Welding and Cutting of Metals (No. 725 - 67), Instructions on Designing Ventilation and the Use of Individual Protective Measures During Electric Welding and Gas-Cutting in Ship-Building Industry (1965), Temporary Instructions on Designing Ventilation and the Use of Individual Protection During Welding and Cutting of Al-Mg and Ti alloys (1962), and Instructions on Designing Ventilation and Hot-Air Heating of Shipbuilding Rooms (VNIOT, 1968).

4.2. Dust and gases during manual, semiautomatic and automatic welding at stationary work areas shall be sucked off directly from places where they are formed.

4.3. While designing local suction units, the suction speed at a

welding point shall be

- (a) 0.5 m/sec for steel welded in carbon dioxide;
- (b) 0.3 m/sec for nonferrous metals welder in argon, helium and N₂;
- (c) 0.3 m/sec for aluminum and titanium welded in argon and helium;

/244

These speeds do not disturb the gaseous shielding of weld bath and secure elimination of dust and harmful gases.

4.4. The following local exhaust units are recommended for manual and semi-automatic welding on benches:

- (a) slanted enclosures resembling exhaust hoods;
- (b) rotatable bench^{es} with adjustable enclosures;
- (c) elongated slanted hood for a continuous suction;
- (d) welding bench for each welders with built-in suction units (panel 750 x 200 mm and grid 1000 x 500 mm);
- (e) rotatable benches for welders and assemblers with built-in suction units;
- (f) vertical panels for a continuous suction.

Appendix 5 (Figures 1-7) presents schematics and other data for the above units.

4.5. Local suction units attached to welding devices shall be used during assembly-line welding of items containing electric conductors and manipulating keys.

4.6. For welding individual items up to 2 m in size, rotatable exhaust units shall be used for items of the same height, and liftable and rotatable units for items of various height.

Note. It is recommended to use exhaust units developed at the VNII on Labor Safety and by the Design Institute No. 1 in Leningrad. Schematics and data on these units are shown in Appendix 5.

4.7. Local suction units either built-in or attached to welding machines shall be used during automatic welding in temporary areas.

For welding of steel in CO₂, machines shall be used with special gas-electric burners with built-in suction (ADS-1000-2U for butt welds, and ASU-6M for square tee joints).

Machines for aluminum alloys shall be equipped with suspended funnel-shaped receptacles.

4.8. Rooms in which welding is performed in shielding gases shall

be equipped with a general ventilation.

/244

4.9. The air circulation in a shop shall be determined on the basis that 25% of dust escapes from welding areas equipped with local ventilation systems and from other welding areas without any type of ventilation.

Note. Welders working without local ventilation units shall use individual means of protection of the respiratory organs.

4.10. Data regarding various type of harmful substances produced during welding in shielding gases are presented in Appendix 2.

Appendix 6 gives computed data on air circulation per kg of consumed electrode wire.

Note. The concentration of dust in the shop air considered in computations of the air circulation was assumed to be 2 mg/m^3 .

4.11. Calculations of the air circulation shall be conducted on the /245 basis of the most harmful component:

(a) with respect to a total dust concentration yielded when welding with a welding wire containing less than 2.5% of manganese and less than 1% of chromium; similarly during welding of aluminum and titanium alloys;

(b) with respect to manganese compounds, when the welding wire contains 2, 5 of higher percentage of Mn;

(c) with respect to chromium compounds, when the welding wire contains more than 1% of Cr;

(d) with respect to copper compounds, when welding the copper based alloys.

Allowable concentrations of ^{the}welding dust and harmful substances in it are shown in Appendix 2.

4.12. The air circulation in not easily accessible spaces where welding works are carried out could be lower but it should secure an acceptable dilution of the produced dust and gases. Welders in these cases must be equipped with individual protective means for respiratory organs, with the fresh air supply.

4.13. In the case of general ventilation, the duct eliminating polluted air shall be located as far as possible ^{from} the opening letting the fresh air in.

When shielding gases are used which are heavier than air, the exhaust opening shall be located at the floor level.

4.15. The air shall be eliminated to the exterior of shops according to

sanitary requirements toward ventilation wastes.

/245

Poluted air from confined spaces where portable exhaust units are used can be released into a general shop. This fact should be accounted for while calculating the air circulation in a given shop. However, it is forbidden to relase into a shop the poluted air containing more than 1% of Cr, or more than 2.5% of Mn.

4.16. In order to compensate for the exhaust air released into shops, the in-coming air supplied by mechanical systems shall be heated during winter months. The amount of in-coming and outgoing air shall be equal.

4.17. An increased amount of fresh air shall be supplied into shops where assembly and welding operations are performed in carbon dioxide. The maximum air supply within working zones shall be 0.5 m/sec.

Air supply ducts for intensive distribution of air shall be equipped with rotatable devices allowing to change the air flow angle, as a function of the supply air temperature during different seasons.

4.18. The fresh air into work areas shall be supplied in a dispersive manner and air outlets shall be arranged in a pattern securing a minimum air motion at work places in shops designated for welding copper, aluminum and titanium alloys.

4.19. Meteorological conditions in accordance with Sanitary Standards for Designing Industrial Plants (SN 245 - 63; presently SN 246 - 71 is in force) shall be maintained in industrial shops designated for welding.

/246

4.20. Shops shall be heated, as a rule, by hot air combined with plenum ventilation. In addition, air-heating units are recommended.

4.21. Steam heating is recommended for small shops. Steam heaters shall have smooth surfaces permitting their easy cleaning.

4.22. Additional heating units, or ducts supplying heated air shall be installed at windows according to SN adn P II-G.7 - 62, Section 4.72 in shops heated with hot air where work areas are located at 2 m from exterior walls with windows.

4.23. All traffic gates shall be equipped with hot-air screens. The amount of air for these screens must be accounted for when designing the heating systems.

4.24. It is unnecessary to install the hot-air screens at large gates

intended for the delivery of large size pieces because they are used very seldom. However, in places where these gates can not be closed air-tight, or have large gaps, a local hot-air screens are recommended. These screens shall be designed according to rules developed at the VNII of Labor Safety and published in Instruction of the Design of Hot-Air Screens for Localized Cold Air Opening (Leningrad, 1970).

/246

5. Safety Requirements for Welding Equipment

5.1. Welding equipment shall be arranged and operated according to Design Rules for Electric Equipment, Industrial Rules for Operating Electric Devices and Safety Rules for Electric Equipment.

Assembling and operating electric welding equipment on ships shall correspond to Labor Safety Orders for Electric Power Supply to Ships Under Construction and Repair (Approved by the Central Committee Presidium of the Machine-Building Labor Union on February 6, 1959).

5.2. In the case of the malfunction of welding equipment, all welding operations must be suspended until defects are eliminated.

5.3. Repairing of welding equipment on pieces being welded shall be forbidden. When this can not be avoided, the current to the equipment must be shut off.

/247

5.4. Protective glasses shall be used when cleaning the burner nozzle or attachments for metal droplets, dust and soot.

5.5. Special wrenches shall be used while changing conductor end-pieces to burners.

5.6. The current feeding mechanism of welding unit shall be safely insulated from pieces being welded. In the case of insulation breakage, all welding operations shall be suspended.

5.7. Burner's handles shall be reliably insulated. Welding shall not be permitted with equipment having damaged insulation.

5.8. Electric motors that are built-in into burners for semi-automatic welding shall be supplied with power not exceeding 36V.

5.9. Flexible welding hoses for electrode wire for semi-automatic units shall be insulated.

5.10. Electric leads from welding burners to control panels shall

have reliable insulation.

/247

5.11. Burners for manual argon welding shall not have bare current conducting parts.

5.12. Hoses for water and gas shall be in good condition and shall not leak at a pipe union.

Gas hoses shall be tested with a compressed air or gas under water against leakage at least once a quarter. The obtained results shall be recorded in a log book.

5.13. Rubber hoses that withstand 1.5 times the working pressure shall be used for gas and water. Hoses of average flexibility shall be used for these purposes, according to GOST 5496 - 67, type II.

5.14. When welding units are not equipped with the water flow controlling valves, the flow of water from welding burners shall be visible. As soon as the water stops to flow, all welding operations must be also stopped.

5.15. All gas and water -conducting equipment shall be leakproof. It is categorically forbidden to operate welding units having the leakage of gas or water.

5.16. Neither gas or water -conducting devices shall be repaired while under pressure.

5.17. Neither the cooling system of a burner, nor the shielding gas system shall be repaired when there is a vapor or hot water in a welding unit (automatic and semiautomatic welding of titanium).

6. Labor Safety During the Use of Cylinders and Containers With Liquefied Gas^{es} or of Ramps for Centralized Use of Shielding Gases from Cylinders

/248

6.1. Cylinders and containers with liquefied gases and ramps for shielding gases shall be used according to Design Rules and Safety Operation of Pressure Vessels, approved by the USSR State Controlling Agency.

6.2. In order to avoid freezing of cylinders^{ders} containing carbon dioxide in winter when welding outside (of shops), they shall be kept in heated rooms.

6.3. Heating of frozen CO₂ cylinders (or reductors) with burner flame

or steam shall be forbidden. They must be brought into a room with 20-25°C and let ~~them~~ unfreeze slowly. However, water heated to 25°C can be used for unfreezing the gas cylinders.

6.4. Valves of cylinders and reducers shall not be repaired in working areas. All repair work of valves shall be conducted by trained personnel.

6.5. Cylinders valves shall be opened with special keys or manually. Cylinders and valves shall be protected from impacts.

6.6. In order to prevent freezing of CO₂ in^a reducer, a heater shall be placed in front of it.

The heating filament of the reducer heater shall not have any contact with the gas cylinder. The heater shall be supplied with 36 V and 70 W current.

6.7. Only employees who passed successfully the test on Design Rules and Safety Operation of Pressure Vessels shall be allowed to handle the containers with liquefied gases, as well as the system supplying shielding gases to welders.

6.8. All equipment under pressure (containers, storage tanks, ramp systems) shall be registered with State Industrial Control Agency.

6.9. Areas where storage tanks with liquefied gases are kept shall be fenced; the distance between tanks and the fence shall not be less than one meter. There shall not be any sources of heat near containers.

When tank trucks are used as storage units for liquefied gases, appropriate telfers are provided for their loading and unloading.

6.10. When storage tanks are kept outside of buildings, they shall be provided with sheds for protection against direct sun rays and precipitations.

6.11. While using containers with liquefied CO₂, the working pressure shall be kept automatically at 8 - 12 kg/cm².

The pressure in the container with liquefied CO₂ shall not be less than 7 kg/cm².

6.12. Rooms with container or a ramp shall be well ventilated, and the temperature in them shall not exceed 25°C.

6.13. The platform from which shielding gases are supplied to welding areas shall contain not more than 20 cylinders.

Valves of cylinders and collectors shall be turned off before removing

empty cylinders.

Gases shall not leak at joints; repair of leakages shall be conducted only with all valves closed.

No other items or fuels shall be kept at the same platform with gas cylinders.

6.14. Hot water or steam shall be used for heating purposes when carbon dioxide is supplied from a centralized area to welding posts.

6.15. Additional safety measures shall be maintained while using containers with liquefied argon. They are:

- (a) containers can be emptied only with the use of evaporator;
- (b) valves shall be opened and closed gradually;
- (c) bolts and packing glands shall not be tightened when valves and pipes are under pressure;
- (d) hoses shall be disconnected only when all argon is evaporated;
- (e) liquid argon shall not be in contact with skin because it could cause severe frost bite;
- (f) a care shall be taken while disconnecting hoses because of a possible discharge of gaseous or liquid argon from them.

6.16. All safety devices must be under a constant control during use of containers or ramps for a centralized supply of shielding gases. Safety valves shall be carefully adjusted, sealed and kept clean.

6.17. While using the gas from containers, it is forbidden

- (a) to conduct any repair work;
- (b) to heat pipes and devices with an open flame;
- (c) to bend sharply gas-supplying hoses;
- (d) to tighten joints while pipes are under pressure.

6.18. Instruction on safety procedures must be developed before use of containers, storage tanks and cylinders with carbon dioxide and argon, as well as of ramps supplying shielding gases to welding posts.

Note. During the development of instructions it is recommended to use the following reference sources:

1. Instruction No. I-34141 on Design and Operation of Liquefied Gas UG200-M (VNIPTKh of Petroleum Apparatus, Volgograd).
2. Instruction No. I-34173 on Design and Operation of Storage Ramp

System for Supplying Carbon Dioxide to Welding Posts (VNIIP TKh of Petroleum Apparatus, Volgograd).

/249

3. Industrial Rules for Filling, Transportation and Centralized Use of Liquefied Supercooled Carbon Dioxide in Isothermal Containers (UKRNiiPP, Kharkov).

4. Instruction on Centralized Use of Liquefied CO₂ from Steel Cylinders (UKRNiIPP, Kharkov).

5. Instruction on Use of Device 8G513 for Transportation of Pure Argon (Leningrad Oxygen-Producing Plant).

7. Individual Protection Measures

/250

7.1. Individual protection measures for respiratory organs are used in exceptional cases when it is impossible to maintain the allowable level of gases and dust by ordinary ventilation systems.

7.2. In those cases when the concentration of gases (ozone, CO and nitrogen oxides) in the welder's breathing zone does not exceed the maximum permissible level, and the concentration of dust is higher, welders shall be provided with dust-filtering respirators (ShB-1, Lepestok or Astra, for example). When the concentration of gases and dust exceed the maximum permissible levels in confined and not easily accessible spaces, welders are provided with breathing devices with a forced supply of fresh air (gas mask PSh-2-57, RMP-62, breathing units ASM and others).

7.3. Eyes shall be protected with light filters according to GOST 1361 - 69 (Shields and Masks for Protection of Welders With Light Filters) and GOST 9497 - 60 (Glass Light Filters for Protection of Eyes From Harmful Industrial Radiation).

7.4. The compressed air for breathing devices shall not contain water droplets, oil, dust, hydrocarbon vapors and carbon monoxide.

7.5. When welding with consumable electrodes at many work areas, welders must be provided with special protective goggles of closed type in addition to shields and masks against ultraviolet radiation.

7.6. Welds shall be cleaned of scale and dust only when welders are provided with protective goggles.

7.7. Electric welders shall be provided with helmets while welding

in places where they could hurt their heads. For convenience a use of helmets with protective face shields is recommended.

7.8. Welders shall be provided with ear muffles (designed by VNIOT-2, for example) in the presence of excessive noise.

/250

7.9. Special work clothes and footwear shall be issued for electric welders according to Standards and Rules Regarding Free Work Clothes Footwear and Protective Devices for Workers and Employees.

7.10. For convenience welders can use canvas gloves in place of mittens when welding with nonconsumable electrodes.

8. Conclusion

8.1. Administrative personnel of plants (directors, chief engineers, formans and heads of projects) are responsible for the fulfillment of these Orders.

8.2. Violators of these Orders and those responsible for their enforcement shall be punished according to existing laws.

8.3. Industrial union inspectors, committees of labor safety and general inspectors in individual union groups are responsible for conducting periodic control regarding the fulfillment of these Orders.

/251

Gas	Physico-chemical characteristics	Conditions produced by gases that are dangerous for welders
Argon	Inert gas, without smell, color and taste, non-toxic, heavier than air (density with respect to air is 1.4)	Can be accumulated ^u in confined spaces, wells and depression and by displacing oxygen can create suffocating conditions
Helium	Inert gas, non-toxic, lighter than air (density with respect to air is 0.14)	Can be accumulated in upper sections of shops and confined spaces and produce suffocating conditions.
Nitrogen	Gas without smell, taste and color; its density is close to that of the air	Is dangerous for health when it replaces the oxygen.
Carbon dioxide	Colorless of a slightly acid smell and taste; heavier than air by 1.5 times.	Can be accumulated in lower sections of confined spaces and by displacing oxygen can lead to lose of consciousness and suffocation. When its concentration exceeds 1%, it irritates the respiratory organs and could produce ill effects.

Appendix 2. Amount of Harmful Substances as a Function of Welding
Materials and Types of Welding

/252

Type of welding and welding materials	Harmful substances	Concn. of harmful substances, g/kg	Max. permissible concn., mg/m	
Welding with consumable electrodes in Ar or He	dust	20.0	2.0	
	Aluminum alloys	nitrogen oxides	2.5	5.0
		magnesium oxides	3.0	-
		ozone	0.1	0.1
	Titanium alloys	dust	5.0	6.0
		ozone	0.1	0.1
	Copper-based alloys, welding wire MNZhKT5-1-0.2-0.2	dust	18.0	1.0
		copper and its oxides	11.0	1.0
		nickel oxides	0.7	0.5
		zinc oxides	0.02	5.0
Welding with nonconsumable electrodes in Ar or He	dust	0.5	2.0	
	Aluminum alloys	W compounds	1.5	6.0
		Mg oxides	0.75 [-
		ozone	0.08	0.1
	Titanium alloys	dust	3.5	6.0
		ozone	0.08	0.1
Welding in CO ₂	dust	8.0	4.0	
	Carbon and low-alloyed steel; Sv-08G2S wire, I _w = 120-300 A	Mn oxides	0.5	0.3
		Cr oxides	0.02	0.1
		Ni oxides	0.03	0.5
		CO	5.0	30.0
	Carbon and low-alloyed steel; Sv-08G2S wire; I _w = 350-450 A	dust	14.0	4.0
		Mn oxides	0.8	0.3
		Cr oxides	0.03	0.1
		Ni oxides	0.03	0.5
		CO	6.0	30.0
	High-strength and austenite steel; Sv-08Kh19N11 F2S2 wire; I _w ≤ 300 A	dust	8.0	4.0
		Mn oxides	0.2	0.3
		Cr oxides	0.6	0.1
		Ni oxides	0.1	0.5
		CO	5.0	30.0
	High-strength and austenite steel; wire Sv-08G6Kh16N25M6; I _w ≤ 300 A	dust	15.0	4.0
		Mn oxides	1.8	0.3
		Ni oxides	2.0	0.5
	Cr oxides	0.5	0.1	
	CO	5.0	30.0	

Appendix 3. Intensity of Thermal Radiation in Relation to the Type of
Welding

1253

Welding	Thermal radiation, kcal/cm ²	
	at welder's hand	in front of welder's face
In CO ₂ with I _w = 150-250 A	0.5-2.0	0.3-0.5
In CO ₂ with I _w = 300-400 A	6.0-8.0	1.0-2.0
In CO ₂ with I _w = 500 A	10.0	4.0
With nonconsumable electrode in Ar or He; Al-Mg alloys	0.5-0.2	0.5-1.5
With consumable electrodes in Ar or He; Al-Mg alloys	1.0-3.0	1.0-2.0
With nonconsumable electrodes in Ar or He; Ti alloys	1.0-1.5	0.5
With consumable electrodes in Ar or He; Ti alloys	2-4	1.0-2.5

Appendix 4. Recommended Types of Gas Analyzers for Checking
the Air Composition

/254

Type of analyzer	General purpose	Manufacturing plant
Automatic MN5121-MN5132	For determining the concentration of oxygen in air	Plant for gas analyzers in Vyru town
Automatic OA2109	For determining the concentration of CO, CO ₂ and methane in air	Plant for automatic devices in Smolensk
Automatic OA2209	Same	Same
Automatic OA2309	"	"
Automatic TP2220	For determining the concentration of CO ₂ in air	Plant for gas analyzers in Vyru town
Chemical portable for manual operation GKhP-2, GKhP-3M	For determining the volumetric percentage of CO, CO ₂ and oxygen in air	Plant for laboratory apparatus in Klin
Interferential portable PGA	For determining the concentration of oxygen and CO ₂ in air	Siberial plant for hydraulic and mining instruments

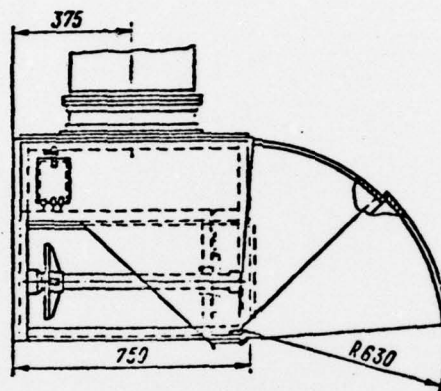
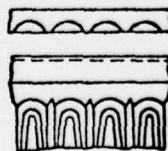
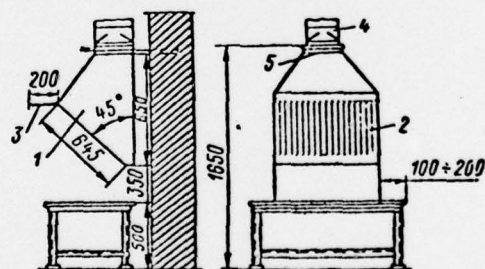

Figure 1. Rotatable bench with movable hood



detail of the stamped screen

Figure 2. Inclined hood for a uniform continuous suction

- 1 - air inlet; 2 - stamped screen;
- 3 - overhang; 4 - air duct; 5 - slide valve.

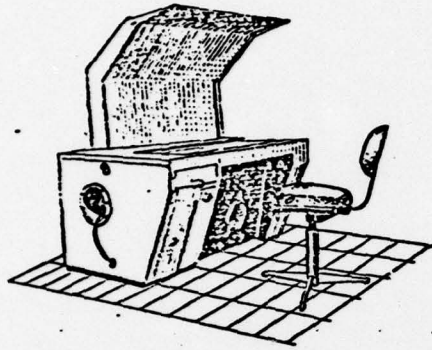

Figure 3. Welder's bench with built-in suction unit

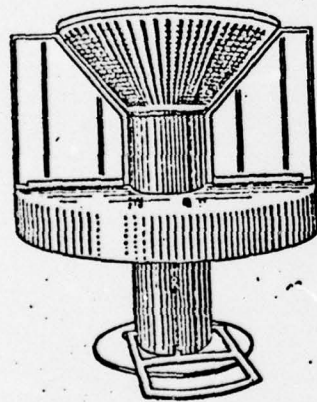

Figure 4. Rotatable bench for welding and assembling, with built-in suction unit

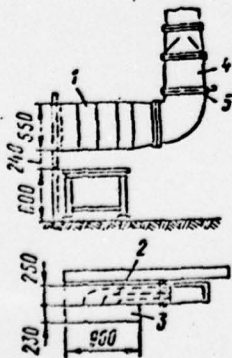

Figure 5. Vertical unit for a uniform continuous suction.

- 1 - air inlet; 2 - splits; 3 - overhang;
- 4 - air duct; 5 - sliding valve.

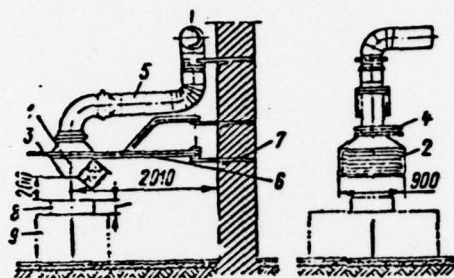

Figure 6. Two-duct rotatable air inlet unit LIOT-1.

- 1 - air inlet; 2 - suction screen; 3 - overhang;
 4 - sliding valve; 5 - air duct; 6 - rotatable arm;
 7 - fixed support; 8 - pieces to be welded; 9 - work bench

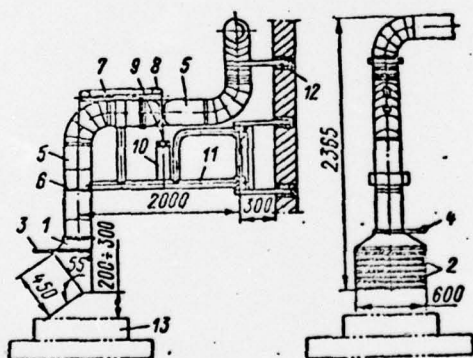

Figure 7. Rotatable and lifting air intake unit LIOT-2.

- 1 - air inlet; 2 - suction screen; 3 - overhang;
 4 - sliding valve; 5 - air duct; 6 - connecting strips;
 7 - steel line; 8 - rollers; 9 - counterweight;
 10 - guide bushing; 11 - rotatable arm; 12 - fixed support;
 13 - piece to be welded.

Name of the gas and dust suction units	Figure No.	Size of suction opening, mm	Air speed in suction screen, m/sec	Volume of the sucked air, m ³ /hr	Application conditions for local suction units	Remarks
Exhaust hood	-	700x400	0.5-0.7	600-800	Welding of small pieces	
Rotatable bench with movable hood	1	1000x630	0.5	1200	Welding of pieces 0.8 m long and 0.4 m in height	This unit was developed at Moscow Design Bureau; blueprints are kept in a log OV-02-151, Moscow, TsITP, 1966.
Slanted panel for a uniform suction	2	600x645 750x645 900x645	0.9	1250 1600 1900	Welding of pieces up to 1 m long and 0.5 m in height	This unit was developed at VNIOT in Leningrad. Blueprints are kept at TsIP, Moscow in log series 4.904-37, 1967.
Bench for welding with built-in suction unit	3	Panel 750x200 screen 1000x500	2.9 0.8	1400	Welding of pieces up to 0.8 m long and up to 0.4 m in height	This unit was developed at BISP and NIIST in Kiev. The built-in ventilator Ts4-70, No 2 and 5; n=2800 rpm; N=0.8 kW provides a variable operation.
Rotatable bench for assembly and welding with built-in suction	4	1500 bench diameter	1200x480	2000	Welding of pieces up to 0.4 m in height	This unit was developed at VISP in Kiev.

Appendix 5 (cont.)

Vertical panel for a uniform suction	900x610	1.1	2100	Welding of pieces up to 1 m long and 0.5 m in height	This unit was developed at the Institute of Labor Hygiene and Occupational Diseases, AMN SSSR, Moscow
Two-duct rotatable air suction unit LIOT-1	900x450 x2	1.4	4000	Welding of pieces 2x1 m and of identical height on stationary benches	This unit was designed at VNIOT in Leningrad. Blueprints are kept in a log entitled "Local Ventilation During Electric Welding and Cutting," 1970
Rotatable and lifting air suction unit LIOT-2	600x450	2.0	2000	Welding of pieces 2x1 m in area of the same height on stationary benches	Burners were designed by TsNIITS
Built-in local suction unit for ADS-1000-2U welding machine	-	-	60	Welding of steel in CO ₂ , primarily for butt welding	"
Built-in local suction unit for automatic welding machine ASU-6M	-	-	40	Welding of steel in CO ₂ ; for welding tee joints	Experimental unit. The shape of inlet and the method of attachment to burners needs further refinements.
Suspended dust and gas inlet unit for automatic ADS-1000 machine for aluminum alloys	120 in diam.	6.0	300	Welding of Al-Mg alloys in argon	"

Appendix 6. Calculated Air Circulation to be Used When Designing
 a General Ventilation System (in m³ per kg of consumed
 welding wire)

/260

Steels and alloys to be welded and welding materials	Shielding gas	Calculated air circulation, m ³ /kg
Carbon and low-alloyed steel; Sv-08G2S welding wire: $I_w \leq 300$ A $I_w = 350-450$ A	Carbon dioxide	4,000 7,000
High-strength and austenite steels; Sv-08Kh19N11F2S2 and Sv-08G6Kh16N25M6 welding wire, $I_w \leq 300$ A	Carbon dioxide	12,000
Aluminum alloys: consumable electrodes nonconsumable tungsten electrode	Argon or Helium	10,000 2,500
Titanium alloys: consumable electrodes nonconsumable tungsten electrodes	Argon or Helium	1,000 600
Copper based alloys; MN ZhKT5-1-0.2-0.2	Argon or Helium	11,000