

AD-A039 460

ARMY ELECTRONICS COMMAND FORT MONMOUTH N J  
MODULATOR - REPETITIVELY PULSED FIELD EMISSION ELECTRON BEAM GU--ETC(U)  
APR 77 @ J DEZENBERG, W WRIGHT , S SCHNEIDER  
ECOM-4489

F/G 9/5

UNCLASSIFIED

NL

| OF |

AD  
A039460



END

DATE  
FILMED  
6-77



12  
B-5

Research and Development Technical Report  
ECOM - 4489

AD A 039460

MODULATOR-REPETITIVELY PULSED FIELD EMISSION  
ELECTRON BEAM GUN INTERFACE

George J. Dezenberg  
U. S. Army Missile Command  
  
W. Wright  
S. Schneider  
Electronics Technology & Devices Laboratory

April 1977

DISTRIBUTION STATEMENT  
Approved for public release;  
distribution unlimited.

DDC  
RECEIVED  
MAY 13 1977  
D

ADU NU. FILE COPY

ECOM

U.S. ARMY ELECTRONICS COMMAND FORT MONMOUTH, NEW JERSEY 07703

## NOTICES

### Disclaimers

The findings in this report are not to be construed as an official Department of the Army position, unless so designated by other authorized documents.

The citation of trade names and names of manufacturers in this report is not to be construed as official Government indorsement or approval of commercial products or services referenced herein.

### Disposition

Destroy this report when it is no longer needed. Do not return it to the originator.

UNCLASSIFIED

SECURITY CLASSIFICATION OF THIS PAGE (When Data Entered)

REPORT DOCUMENTATION PAGE		READ INSTRUCTIONS BEFORE COMPLETING FORM
1. REPORT NUMBER ECOM-4489 ✓	2. GOVT ACCESSION NO.	3. RECIPIENT'S CATALOG NUMBER
4. TITLE (and Subtitle) Modulator - Repetitively Pulsed Field Emission Electron Beam Gun Interface	5. TYPE OF REPORT & PERIOD COVERED Research and development Technical Report.	6. PERFORMING ORG. REPORT NUMBER
7. AUTHOR(s) George J. Dezenberg, US Army Missile Cmd, Redstone Arsenal, AL and W. Wright, and S. Schneider, USAETDL, Ft Monmouth	8. CONTRACT OR GRANT NUMBER(s)	
9. PERFORMING ORGANIZATION NAME AND ADDRESS US Army Electronics Command ✓ (ATTN: DRSEL-TL-BG) Fort Monmouth, NJ 07703	10. PROGRAM ELEMENT, PROJECT, TASK AREA & WORK UNIT NUMBERS 117 62705 AH94 E1 05	
11. CONTROLLING OFFICE NAME AND ADDRESS Beam, Plasma and Display Technical Area US Army Electronics Technology and Devices Lab (ATTN: DRSEL-TL-B)	12. REPORT DATE 11 April 1977	
13. MONITORING AGENCY NAME & ADDRESS (if different from Controlling Office) George J. Dezenberg, William Wright Sol Schneider	13. NUMBER OF PAGES 6	15. SECURITY CLASS. (of this report) Unclassified
16. DISTRIBUTION STATEMENT (of this Report) Approved for public release; distribution unlimited. 14 ECOM-4489 ✓		15a. DECLASSIFICATION/DOWNGRADING SCHEDULE
17. DISTRIBUTION STATEMENT (of the abstract entered in Block 20, if different from Report)		
18. SUPPLEMENTARY NOTES		
19. KEY WORDS (Continue on reverse side if necessary and identify by block number) Electron Beam Gun Blumlein Modulator Pulse Power Field Emission High Voltage		
20. ABSTRACT (Continue on reverse side if necessary and identify by block number) A field emission electron beam gun is repetitively pulsed with a modulator in a Blumlein arrangement. The modulator is operated in an unmatched condition with the output connected directly to the gun. The gun is a time varying monotonically decreasing impedance load while the modulator impedance is constant. The modulator-gun configuration produces an initial voltage peak which approaches twice the value of the charge voltage to promote gun emission. After the initial peak, the load voltage assumes a value determined by the gun		

DD FORM 1 JAN 73 1473

EDITION OF 1 NOV 65 IS OBSOLETE

UNCLASSIFIED

SECURITY CLASSIFICATION OF THIS PAGE (When Data Entered)

037 620

1B

(#20 - Contd)

impedance. Peak voltages in excess of 350 kV and peak currents up to 8 kA have been delivered in 5  $\mu$ s pulses by the modulator to the gun. The modulator routinely operates at 50 Hz repetition rate, 135 kV recharge voltage and about 3 amps of average current.

ACCESSION FOR	
NTIS	White Section <input checked="" type="checkbox"/>
DDC	Buff Section <input type="checkbox"/>
UNANNOUNCED	<input type="checkbox"/>
JUSTIFICATION	
BY	
CONTRIBUTION/AVAILABILITY CODES	
DATE AVAIL. and/or SPECIAL	
A	

DDC  
RECEIVED  
MAY 13 1977  
D

MODULATOR - REPETITIVELY PULSED FIELD EMISSION  
ELECTRON BEAM GUN INTERFACE

by

George J. Dezenberg  
US Army Missile Command  
Redstone Arsenal, Alabama 35809

William Wright and Sol Schneider  
US Army Electronics Command  
Fort Monmouth, New Jersey 07703

ABSTRACT

4  
A field emission electron beam gun is repetitively pulsed with a modulator in a Blumlein arrangement. The modulator is operated in an unmatched condition with the output connected directly to the gun. The gun is a time varying monotonically decreasing impedance load while the modulator impedance is constant. The modulator-gun configuration produces an initial voltage peak which approaches twice the value of the charge voltage to promote gun emission. After the initial peak, the load voltage assumes a value determined by the gun impedance. Peak voltages in excess of 350 kV and peak currents up to 8 kA have been delivered in 5  $\mu$ s pulses by the modulator to the gun. The modulator routinely operates at 50 Hz repetition rate, 135 kV recharge voltage and about 3 amps of average current.

Introduction

The modulator and electron beam gun described in this paper are a part of a repetitively pulsed CO<sub>2</sub> laser system called CCEBL (an acronym for Cold Cathode Electron Beam Laser) operating at the US Army Missile Command. The CCEBL uses an unmodulated sustainer field as shown in Figure 1. The voltage on the sustainer capacitor is at a value below laser gas breakdown. Conduction occurs when electrons from the electron beam gun are injected into the sustainer field region. Conduction ceases when the electron beam gun is turned off. Since the electron beam gun controls sustainer conduction and hence, laser action, the modulator-gun interface is the determining factor in the operation of the CCEBL.

Cold cathode, or field emission, electron beam guns similar to the one described in this work have been used in CO<sub>2</sub>, CO, excimer, and electrically initiated chemical laser systems. Most of these laser applications have been in Marx-generator driven single pulse systems. A GIN-400 generator was used to provide up to 300 kV, 500 A pulses of about 1- $\mu$ s duration at a 5 Hz rate to a cold-cathode electron beam gun used in a CO<sub>2</sub> laser.<sup>1</sup> A 15-cm by 50-cm cold-cathode electron beam gun has been operated at a 50-Hz rate using a lumped element line driver, pulsed-transformer combination.<sup>2</sup> The open core pulse transformer had a secondary to primary turns ratio of 17.5 to 1 and provided 250 kV, 750 A pulses of 3  $\mu$ s duration to the gun. This paper describes the characteristics of the first Blumlein modulator driven repetitively pulsed cold-cathode electron beam gun.

### Gun Characteristics

The diode gun used in this work, designed with the aid of John Rink<sup>3</sup>, is shown schematically in Figure 2. A stainless steel gun vacuum chamber housed the aluminum cathode structure, consisting of a 15-cm wide by 1.3-cm thick plate surrounded by a 5-cm diameter field grading ring. A single 2-meter long, 25- $\mu\text{m}$  thick tantalum strip emitter is mounted at the center of the cathode normal to the plate. The emitter edge projects 1.5-cm from the front surface of the cathode. The cathode is mechanically held in the rear by two lucite high voltage bushings separated by 1.22 m. Beldon YR-13181 coaxial cable is used to make electrical connection to the cathode through the oil-filled bushings. The gun anode consists of the flat stainless steel plate and beryllium-copper foil holder shown to the left in Figure 2. The foil holder was slotted to provide about 70% open area. The electrons accelerated into the slotted areas transmit into the laser gas region (sustainer region) through a 25- $\mu\text{m}$  thick, 15-cm by 200-cm wide aluminum foil. In addition to serving as a transmissive element for the electrons, the aluminum foil window is a vacuum seal between the atmospheric pressure laser gas mixture and the  $4 \times 10^{-6}$  torr gun pressure.

An excellent physical explanation of the operation of the cold-cathode electron beam gun is given in reference 4. The main gun features gleaned from this reference are: electron emission is from a plasma initiated at the emitter strip, gun current reaches the space charge limited value near the beginning of the pulse (in about  $2 \mu\text{s}^4$ ), and for constant gun voltage temporal current rise occurs. This latter feature results in a time varying, monotonically decreasing gun impedance.

Typical cold-cathode electron beam gun voltage and current temporal behavior obtained with Marx-generator excitation is illustrated in Figure 3. These data were obtained using a two stage Marx-generator with 0.925  $\mu\text{F}$  per stage and charged to 100 kV. Gun anode-cathode spacing  $d_{ak}$ , the distance between the tantalum strip emitter edge and the inner surface of the foil holder, was 15-cm in Figure 3. The temporal behavior of gun impedance for the experimental conditions of Figure 3 is illustrated in Figure 4. Impedance is calculated by dividing the voltage by the current in Figure 3 on a point-by-point basis. Zero time in Figure 4 is taken to correspond to Marx-generator erection time. During the initial  $2 \mu\text{s}$  of the pulse triggering, noise obscured the voltage and current traces in Figure 3. Hence, the data were averaged in this region. This is indicated by the broken line in Figure 4. The time varying, monotonically decreasing behavior of cold-cathode electron-beam gun impedance is clearly illustrated in Figure 4.

### Modulator Requirements and Design

In addition to matching to a time varying impedance similar to that illustrated in Figure 4, the modulator should satisfy the following requirements for efficient gun operation:

- (1) High initial voltage is required. The electric field on the tantalum strip emitter must be greater than  $10^7$  V/cm to produce initiation.<sup>4</sup>
- (2) Initial voltage risetime should be short. A high  $dV/dt$  is required to produce a multitude of initiation sites on the tantalum strip.<sup>4</sup> A  $dV/dt$  of at least 200 kV in less than 100 nsec would be desirable in the CCEBL system.
- (3) High voltage throughout the pulse is required. This would insure minimum aluminum foil window heating and adequate electron

range to uniformly ionize the laser gas. About 200 kV would be desirable in the CCEBL system.

(4) A very fast voltage fall at the end of the pulse is required. This is needed to reduce aluminum foil window heating. At 100 kV more than 30% of the electron energy is deposited in the aluminum foil. This percentage increases with decreasing voltage.

The initial modulator designed to satisfy the above requirements used PFN's in a Blumlein arrangement and a clamper circuit to compensate for the time varying gun impedance.<sup>5</sup> Although the original design concept is valid, diode reliability problems were encountered due to the high voltage and current operating conditions of the clamper.<sup>5</sup> This led to the modulator redesign shown schematically in Figure 1. There is a distinct design philosophy difference between the initial modulator design and the present design. Initially, with the use of a clamper circuit, the voltage was constant across the gun. The present modulator-gun configuration produces an initial voltage peak which approaches twice the value of the charge voltage to promote gun emission. After the initial peak, the load voltage plateaus at a value determined by the gun impedance.

The gun modulator, as shown in Figure 1, uses two ten stage PFN's in a Blumlein arrangement as before.<sup>5</sup> However, the only diode used in the present modulator is the front-end clipper diode. The charging diode was replaced with a 260-ohm charging resistor. The end of line clipper consisting of a resistor and diode in series was replaced with an end of line termination consisting of a resistor and capacitor in series. The resistor value is equal to the PFN impedance value of 17-ohms and the capacitor value is 0.02  $\mu$ F. This value was chosen to be close to the 0.016  $\mu$ F value of PFN capacitance per stage. Both the resistor in the end-of-line termination and the charging resistor are used to dissipate the reflected energy resulting from either non-initiation of the gun or gun arcs. Two parallel 15-m lengths of 60  $\Omega$  Beldon YR-13181 coaxial cable are used to interconnect the modulator and gun. This minimizes loop inductance and also offers an approximate impedance match between the 34  $\Omega$  modulator impedance and the gun impedance.

#### Modulator-Gun Performance

Single shot gun voltage - current behavior is shown in Figure 5 for an anode-cathode spacing of 17.5 cm and charging voltages of 125 kV and 175 kV. Peak voltages are 210 kV and 260 kV or 1.7 and 1.5 times the charge voltages of 125 kV and 175 kV, respectively. The lower relative peak value at 175 kV charge results because the PFN voltage reaches the gun initiation voltage value of about 150 kV sooner at 175 kV than at 125 kV charge. Gun conduction loads the PFN preventing it from reaching the open circuit value of twice the charge voltage. Gun impedance for the above conditions is shown in Figure 6. Note that the gun impedance at 175 kV charge is always less than the impedance at 125 kV charge. This voltage dependence of impedance is due to the space charge limited conduction characteristics of the gun. That is, the initial current is proportional to voltage to the three-halves power. The impedance levels in Figure 6 show that the modulator operates with a positive mismatch during most of the pulse and a negative mismatch at the end of the pulse.

The voltage risetime of the modulator is about 1  $\mu$ s, as shown in Figure 5. The loop inductance of both PFN's in series accounts for 0.8  $\mu$ s of the risetime. The remainder is due to the interconnections.

The 1  $\mu$ s modulator risetime limits the lifetime of 25  $\mu$ m thick tantalum strip emitters to about  $10^4$  pulses. Thinner emitters have much shorter lifetimes. The number of initial emission sites on the strip emitter is determined by the initial voltage risetime.<sup>4</sup> Fewer sites are produced at slower voltage risetimes. Hence, more emission per site and more local emitter erosion occur.

The modulator output waveforms for single shot and repetitive operation at 170 kV charging voltage are compared in Figure 7. The higher amplitude traces for both gun voltage and current are single shot data; the lower amplitude, wider traces are 50 superimposed pulses at a 50-Hz rate. The amplitude reduction of about 20% is caused by the high power supply impedance resulting in recharge time exceeding the interpulse interval. The 12% amplitude jitter, estimated from the width of the trace, is due to the SCR controller in the Megavolt, Inc. 250 kV, 2A power supply. The recharge cycle consists of a train of current pulses at a 720-Hz rate which produces a staircase PFN charge voltage. When the firing time is unsynchronized to the charging waveform, the PFN voltage can be at a different step for each pulse. This amplitude jitter can be greatly reduced by operating the modulator at a repetition rate exactly a submultiple of 720 Hz and synchronizing firing time to line frequency. The time jitter was in the order of 200 nsec. At a power supply setting of 170 kV the PFN recharge voltage at 50 Hz was about 135 kV and the average current was 3A.

#### Conclusions

The modulator described in this paper successfully drives a cold-cathode electron beam gun at 50 Hz. Comparable single shot laser behavior has been obtained with both the Blumlein modulator and a two stage Marx-generator operating at the same 4.6 kJ energy storage. Work is being performed to optimize laser output by tailoring the impedance characteristics of some of the network sections to improve gun performance. The technique has been established in a low voltage simulation circuit using an electron beam bombarded semiconductor as a time varying load. The simulated load does not precisely match gun characteristics; hence, actual modulator changes must be varied empirically. Consideration is also being given to adding a peaking circuit consisting of a low inductance capacitor and spark gap at the gun connection to increase the initial rate of application of voltage to the gun and hence, increase emitter lifetime.

#### References

1. I. K. Babaev, G. G. Dolgov-Savel'ev, L. L. Kozorovitskii, I. D. Kon'kov, I. A. Leont'ev, V. G. Lyakishev, V. K. Orlov, V. F. Razumtsev, S. N. Telepin, D. D. Khondkevich, and N. V. Cheburkin, Sov. J. Quant. Electron. 4, 777 (1974).
2. G. Loda, System, Science and Software Report No. SSS-75-264 (1975).
3. J. P. Rink, Tech. Digest 1973 International Electron Devices Meeting, 448 (1973).
4. S. Singer, J. S. Ladish, and M. J. Nutter, Los Alamos Scientific Laboratory Report No. LA-UR-75-1585 (1975).
5. W. H. Wright, S. Schneider, and A. J. Buffa, IEEE Conference Record of 1976 Twelfth Modulator Symposium, 163 (1976).

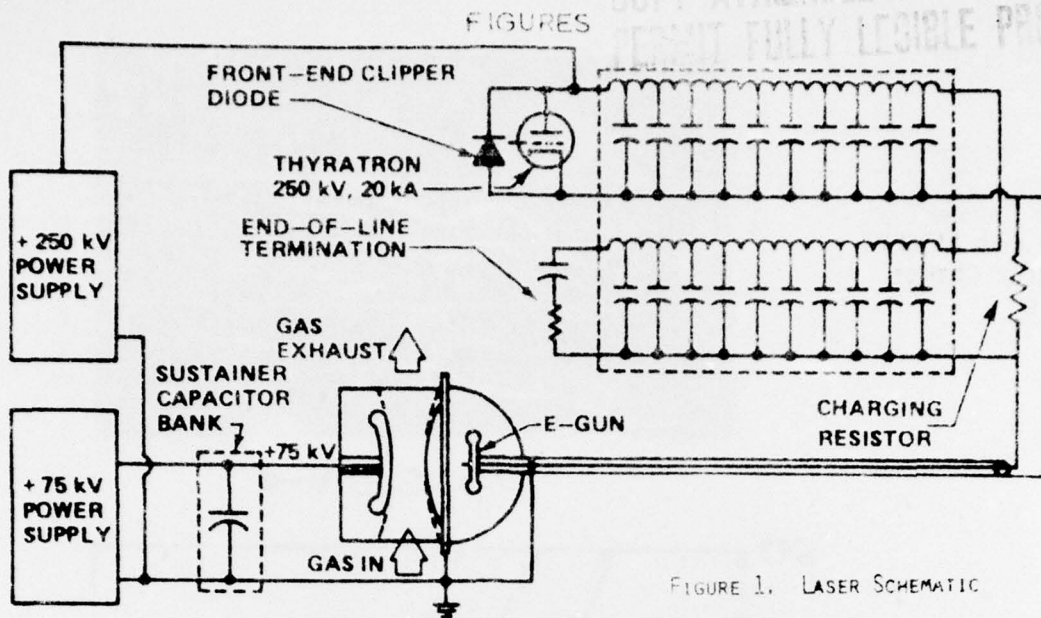

FIGURE 1. LASER SCHEMATIC

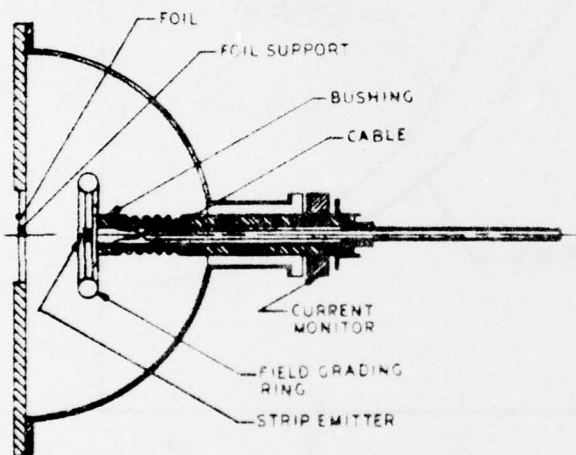

FIGURE 2. GUN CROSS SECTION

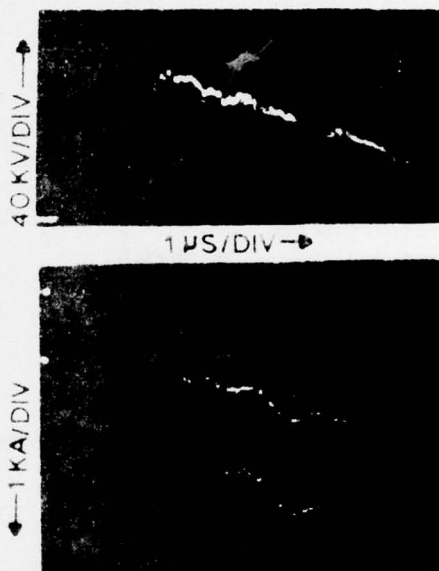

FIGURE 3. GUN VOLTAGE AND  
 GUN STEM CURRENTS WITH  
 MARX GENERATOR EXCITATION

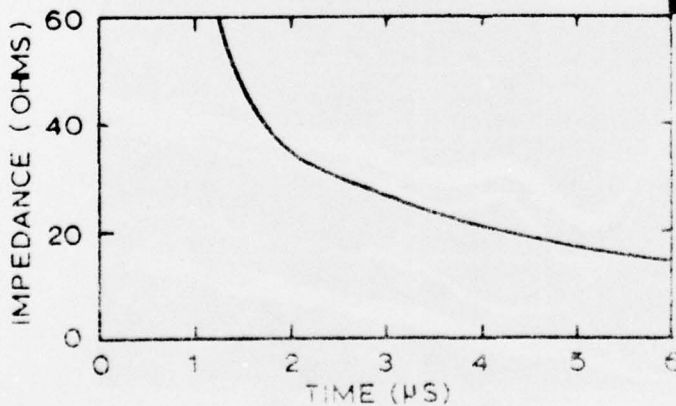

FIGURE 4. TEMPORAL BEHAVIOR  
 OF GUN IMPEDANCE WITH MARX  
 GENERATOR EXCITATION AND  
 $D_{AK} = 15$  CM

Figure 5. Single Shot Gun Voltage and Gun Current at 125 kV and 175 kV Modulator Charge Voltage

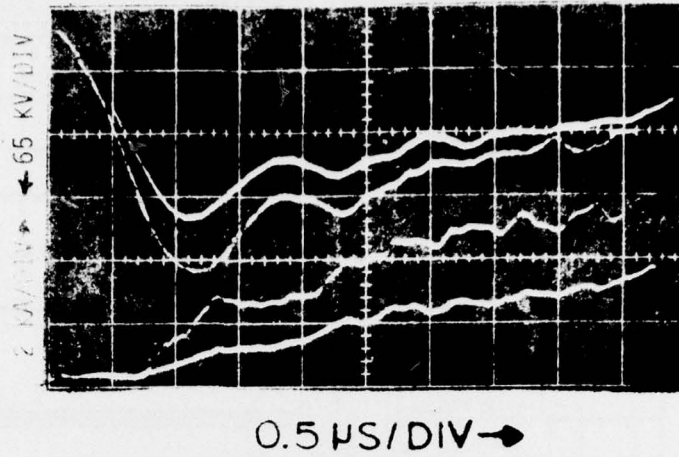

Figure 6. Temporal Behavior of Gun Impedance at 125 kV and 175 kV Modulator Charge Voltage

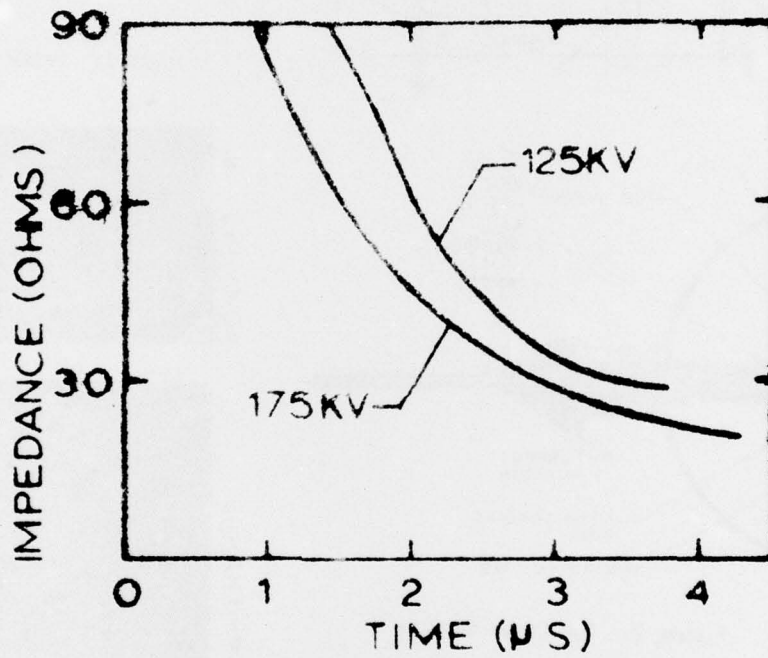

Figure 7. Single Shot and 50 Hz Repetitive Pulse Gun Voltage and Gun Current at 170 kV Modulator Charge Voltage.

