

AD-A039 512

NAVAL POSTGRADUATE SCHOOL MONTEREY CALIF
INTERVAL MODULATION (IM) OF A SINUSOIDAL CARRIER.(U)
FEB 77 G A MYERS, E L KILBORN
NPS-62MV77031

F/G 20/14

UNCLASSIFIED

NL

1 OF 1
AD
A039512



END

DATE
FILMED
6-77

2 B.S.

ADA 039512

NAVAL POSTGRADUATE SCHOOL

Monterey, California



DDC
RECEIVED
MAY 17 1977
150150

INTERVAL MODULATION (IM)
OF A SINUSOIDAL CARRIER

by

Glen A. Myers
and
Edgar Leslie Kilborn, Jr.

February 1977

Approved for public release; distribution unlimited

AD No. _____
DDC FILE COPY

NPS 62Mv77031
February 1977

NAVAL POSTGRADUATE SCHOOL
Monterey, California

Rear Admiral Isham Linder
Superintendent

Jack R. Borsting
Provost

Abstract:

Interval Modulation (IM) of a sinusoidal carrier is a modulation technique unlike AM, FM, or PM. IM conveys the information of a message waveform by modulating an interval between bursts of a sinusoidal carrier. IM is accomplished by sampling the message waveform, producing a delay proportional to the amplitude of the sampled message waveform and, upon the completion of the delay, initiating a burst of a fixed number of full cycles of a sinusoidal carrier. With the completion of the burst, another sample of the message waveform is taken and the sequence of events repeats. Because the length of a burst is fixed and because the delay between bursts is dependent upon the sampled value of the message waveform, the IM signal is non-periodic. An analysis is made of the IM signal modulated by a constant voltage modulating waveform and by general modulating waveforms. Descriptions are given for the circuits used in generation and detection of the IM signal. IM signal parameters are also considered for use with message waveforms in the audio frequency range.

This report was prepared by:

Glen A. Myers
Glen A. Myers

Edgar L. Kilborn, Jr.
Edgar L. Kilborn, Jr. by G.A.M.

Reviewed by:

Donald E. Kirk
Donald E. Kirk, Chairman
Department of Electrical Engineering

Robert R. Fossum
Robert R. Fossum
Dean of Research

PRODUCTION (or)	White Copies	<input type="checkbox"/>
ATIS	Blue Copies	<input type="checkbox"/>
CCC		
REPRODUCED		
JUSTIFICATION		
BY	DISTRIBUTION, AVAILABILITY CODES	
Doc.	NO. 1, 2, 3, 4, 5, 6, 7, 8, 9, 10	

A

UNCLASSIFIED

SECURITY CLASSIFICATION OF THIS PAGE (When Data Entered)

REPORT DOCUMENTATION PAGE		READ INSTRUCTIONS BEFORE COMPLETING FORM
1. REPORT NUMBER 14 NPS 62Mv77031	2. GOVT ACCESSION NO.	3. RECIPIENT'S CATALOG NUMBER
4. TITLE (and Subtitle) 6 Interval Modulation (IM) of a Sinusoidal Carrier.	5. TYPE OF REPORT & PERIOD COVERED 9 Technical Report, February 1977	6. PERFORMING ORG. REPORT NUMBER
7. AUTHOR(s) 10 Glen A./Myers Edgar Leslie/Kilborn, Jr.	8. CONTRACT OR GRANT NUMBER(s)	9. PROGRAM ELEMENT, PROJECT, TASK AREA & WORK UNIT NUMBERS 12 66p.
9. PERFORMING ORGANIZATION NAME AND ADDRESS Naval Postgraduate School Monterey, California 93940	10. CONTROLLING OFFICE NAME AND ADDRESS Naval Postgraduate School Monterey, California 93940	11. REPORT DATE 11 Feb 1977
14. MONITORING AGENCY NAME & ADDRESS (if different from Controlling Office)	12. NUMBER OF PAGES 67	13. SECURITY CLASS. (of this report) UNCLASSIFIED
16. DISTRIBUTION STATEMENT (of this Report) Approved for public release; distribution unlimited.	15. SECURITY CLASS. (of this report) UNCLASSIFIED	18. DECLASSIFICATION/DOWNGRADING SCHEDULE
17. DISTRIBUTION STATEMENT (of the abstract entered in Block 20, if different from Report)		
18. SUPPLEMENTARY NOTES		
19. KEY WORDS (Continue on reverse side if necessary and identify by block number) Interval Modulation (IM)		
20. ABSTRACT (Continue on reverse side if necessary and identify by block number) Interval Modulation (IM) of a sinusoidal carrier is a modulation technique unlike AM, FM, or PM. IM conveys the information of a message waveform by modulating an interval between bursts of a sinusoidal carrier. IM is accomplished by sampling the message waveform, producing a delay proportional to the amplitude of the sampled message waveform and, upon the completion of the delay, initiating a burst of a fixed number of full cycles of a sinusoidal carrier. With the completion of the burst, another sample of		

DD FORM 1473 JAN 73

EDITION OF 1 NOV 68 IS OBSOLETE
S/N 0102-014-6601

UNCLASSIFIED 251 450
SECURITY CLASSIFICATION OF THIS PAGE (When Data Entered)

UNCLASSIFIED

SECURITY CLASSIFICATION OF THIS PAGE(When Data Entered)

the message waveform is taken and the sequence of events repeats. Because the length of a burst is fixed and because the delay between bursts is dependent upon the sampled value of the message waveform, the IM signal is non-periodic. An analysis is made of the IM signal modulated by a constant voltage modulating waveform and by general modulating waveforms. Descriptions are given for the circuits used in generation and detection of the IM signal. IM signal parameters are also considered for use with message waveforms in the audio frequency range.

UNCLASSIFIED

SECURITY CLASSIFICATION OF THIS PAGE(When Data Entered)

ABSTRACT

Interval Modulation (IM) of a sinusoidal carrier is a modulation technique unlike AM, FM, or PM. IM conveys the information of a message waveform by modulating an interval between bursts of a sinusoidal carrier. IM is accomplished by sampling the message waveform, producing a delay proportional to the amplitude of the sampled message waveform and, upon the completion of the delay, initiating a burst of a fixed number of full cycles of a sinusoidal carrier. With the completion of the burst, another sample of the message waveform is taken and the sequence of events repeats. Because the length of a burst is fixed and because the delay between bursts is dependent upon the sampled value of the message waveform, the IM signal is non-periodic. An analysis is made of the IM signal modulated by a constant voltage modulating waveform and by general modulating waveforms. Descriptions are given for the circuits used in generation and detection of the IM signal. IM signal parameters are also considered for use with message waveforms in the audio frequency range.

TABLE OF CONTENTS

I.	INTRODUCTION -----	9
II.	DEVELOPMENT OF INTERVAL MODULATION -----	11
III.	INTERVAL MODULATION WITH DC VOLTAGE MODULATION -----	12
IV.	INTERVAL MODULATION WITH GENERAL MODULATING WAVEFORMS -----	18
V.	INTERVAL MODULATION SIGNAL MODULATOR -----	24
VI.	INTERVAL MODULATION SIGNAL DEMODULATOR -----	30
APPENDIX A:	CHARACTERIZATION OF THE INTERVAL MODULATION FREQUENCY SPECTRUM WITH DC VOLTAGE MODULATION -----	44
APPENDIX B:	CIRCUIT DESCRIPTION OF INTERVAL MODULATION SIGNAL MODULATOR -----	46
APPENDIX C:	CIRCUIT DESCRIPTION OF INTERVAL MODULATION SIGNAL DEMODULATOR -----	62
	LIST OF REFERENCES -----	65
	INITIAL DISTRIBUTION LIST -----	66

LIST OF FIGURES

Fig. 1.	IM SIGNAL -----	9
Fig. 2.	IM SIGNAL MODULATED BY A CONSTANT VOLTAGE --	13
Fig. 3.	SPECTRUM OF IM SIGNAL MODULATED BY A CONSTANT VOLTAGE -----	14
Fig. 4.	EXPANDED PORTION OF FIG. 3 -----	15
Fig. 5.	SPECTRUM OF IM SIGNAL MODULATED BY A CONSTANT VOLTAGE WHEN $x_c \neq 0$ -----	16
Fig. 6.	EXPANDED PORTION OF FIG. 5 -----	16
Fig. 7.	IM SIGNAL MODULATED BY A SINUSOID -----	19
Fig. 8.	SPECTRUM OF IM SIGNAL OF FIG. 7 -----	20
Fig. 9.	EXPANDED PORTION OF FIG. 8 -----	20
Fig. 10.	SPECTRUM OF IM SIGNAL MODULATED BY MUSIC ---	21
Fig. 11.	SPECTRUM OF IM SIGNAL FOR LARGE AMPLITUDE MODULATING SIGNAL	
	a. IM SIGNAL MODULATED BY SINE WAVE -----	22
	b. IM SIGNAL MODULATED BY TRIANGULAR WAVE -	22
	c. IM SIGNAL MODULATED BY SQUARE WAVE -----	23
Fig. 12.	BLOCK DIAGRAM OF THE IM SIGNAL MODULATOR ---	25
Fig. 13.	TIMING DIAGRAM OF THE IM SIGNAL MODULATOR --	27
Fig. 14.	IM GATE SIGNAL AND IM SIGNAL -----	29
Fig. 15.	BLOCK DIAGRAM OF THE IM SIGNAL DEMODULATOR -	31
Fig. 16.	OUTPUT OF IM SIGNAL DEMODULATOR FOR SINUSOIDAL MODULATION	
	a. 450 Hz LOOP FILTER CUTOFF FREQUENCY ----	32
	b. 11 kHz LOOP FILTER CUTOFF FREQUENCY ----	33

Fig. 17.	EFFECTS OF AN INCREASE IN THE AMPLITUDE OF THE MODULATING SIGNAL	
a.	IM SIGNAL -----	35
b.	SPECTRUM OF a. -----	36
c.	EXPANDED PORTION OF b. -----	36
Fig. 18.	EFFECTS OF A FURTHER INCREASE IN THE AMPLITUDE OF THE MODULATING SIGNAL	
a.	IM SIGNAL -----	37
b.	SPECTRUM OF a. -----	38
c.	EXPANDED PORTION OF b. -----	38
Fig. B.1	SAMPLE AND HOLD CIRCUIT -----	50
Fig. B.2	GATED RAMP GENERATOR CIRCUIT -----	51
Fig. B.3	DIFFERENTIAL AMPLIFIER CIRCUIT -----	52
Fig. B.4	ZERO CROSSING DETECTOR CIRCUIT -----	53
Fig. B.5	INTERVAL MODULATED GATE GENERATOR CIRCUIT --	54
Fig. B.6	BURST WINDOW TIMING CIRCUIT -----	55
Fig. B.7	GATED SINUSOIDAL BURST GENERATOR -----	56
Fig. B.8	SINE WAVE INPUT TO MODULATOR AND OUTPUT OF SAMPLE AND HOLD CIRCUIT -----	57
Fig. B.9	GATED RAMP GENERATOR TRIGGERING ZERO CROSSING DETECTOR -----	58
Fig. B.10	ZERO LEVEL FROM ZERO CROSSING DETECTOR TERMINATING MODULATION INTERVAL AND INITIATING BURST WINDOW -----	59
Fig. B.11	TRAILING EDGE OF FINAL ONE-SHOT IN BURST WINDOW TIMING CIRCUIT TERMINATING BURST WINDOW AND INITIATING MODULATION INTERVAL --	60
Fig. B.12	IM GATE SIGNAL AND IM SIGNAL -----	61
Fig. C.1	PHASE-LOCKED LOOP CIRCUIT -----	63
Fig. C.2	AUDIO AMPLIFIER CIRCUIT -----	64

ACKNOWLEDGMENT

The authors gratefully acknowledge the support of a portion of this work by the Naval Postgraduate School Research Foundation.

I. INTRODUCTION

This work is concerned with the use of a modulated interval, between bursts of a sinusoidal carrier, to convey the information in a message waveform. This form of modulation will be referred to as Interval Modulation (IM). As shown in Figure 1, the IM signal consists of bursts, of fixed length T_b , of a sinusoidal carrier which are separated by a modulation interval T_x . IM produces a

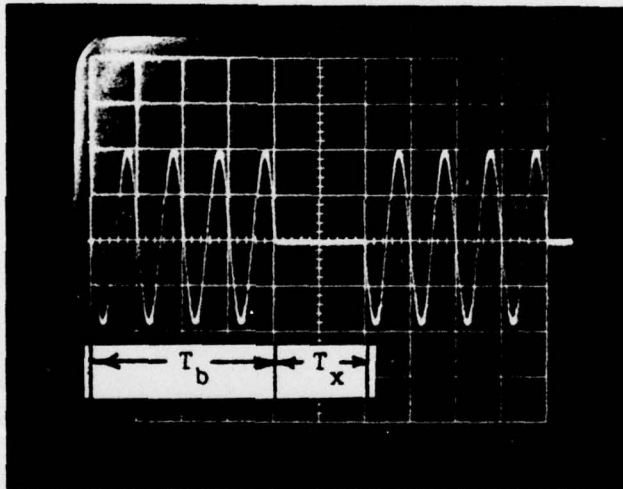

Figure 1. IM SIGNAL

delay between bursts of the sinusoidal carrier. This delay is proportional to the amplitude of the modulating message waveform. Thus, IM is unlike AM, FM, or PM which vary the amplitude, frequency, or phase of a carrier in accordance with a message waveform.

Results indicate that IM is a feasible method of conveying the information of a message waveform. In particular, successful generation and detection of IM signals has been accomplished using modulating message waveforms in the audio frequency range.

The IM signal will first be characterized for modulation by a constant voltage and then consideration will be given to the IM signal with general modulating message waveforms. The design of a modulator for generation of the IM signal and the design of a demodulator for detection of the IM signal are then considered.

Although the use of IM has been successfully demonstrated, there are questions which remain concerning its limitations and capabilities. Therefore, topics recommended for further investigation are given at the end of this report.

II. DEVELOPMENT OF INTERVAL MODULATION

The IM technique conveys the information of a message waveform by modulating an interval between bursts of a sinusoidal carrier. Preliminary investigation of sine wave, square wave, and triangular wave modulation of the IM signal indicated the feasibility of using a phase-locked loop as the demodulator for the IM signal. With this result, effort was directed toward the design of a modulator to produce the IM signal for modulating message waveforms in the audio frequency range. The modulator was designed to allow for wide variations in the IM signal parameters. This was due to the uncertainty which existed as to which IM signal parameters would effect demodulation of the IM signal by a phase-locked loop. It was determined that various combinations of signal parameters were possible which allowed for modulation and demodulation of the IM signal. Specifically, good audio communication was achieved for a sinusoidal carrier frequency of 200 kHz, a burst length of 20 μ s (four full cycles of the carrier per burst), and interval modulation over a range from 9.8 μ s to 10.2 μ s.

III. INTERVAL MODULATION WITH DC VOLTAGE MODULATION

Interval Modulation (IM) of a sinusoidal carrier conveys the information of a modulating message waveform, $m(t)$, by sampling $m(t)$ at the completion of a burst of the sinusoidal carrier and varying the interval before the next burst by an amount proportional to the amplitude of the sampled value of $m(t)$. A complete description of the method used to implement IM will be discussed shortly. For the moment discussion will be limited to consideration of the IM signal modulated by a constant voltage. For a given DC voltage the intervals between the bursts of the sinusoidal carrier are fixed and equal. Therefore, the IM signal modulated by a constant voltage is periodic.

It is possible to characterize the IM signal in the case of modulation by a constant voltage by restricting the length of a burst of the sinusoidal carrier to a fixed number j ($j = 1, 2, 3, \dots$) of full cycles of the sinusoidal carrier and by restricting the modulation interval to an equivalent number k ($k = 0, 1, 2, \dots$) of full cycles of the sinusoidal carrier plus some portion x_0 ($0 \leq x_0 \leq 1$) of a cycle of the sinusoidal carrier. By letting T_c be the period of the sinusoidal carrier in the burst, the length of the burst becomes jT_c and the interval between the bursts becomes $T_x = (k + x_0)T_c$. Therefore, the basic period of the IM signal becomes $T_s = (j + k + x_0)T_c$.

Letting $\ell = j+k$ simplifies this to $T_s = (\ell + x_0)T_c$. Note that $f_s = 1/T_s$ is the sampling frequency for the IM signal modulated by a constant voltage. An example of the IM signal for a particular DC modulating voltage is shown in Figure 2.

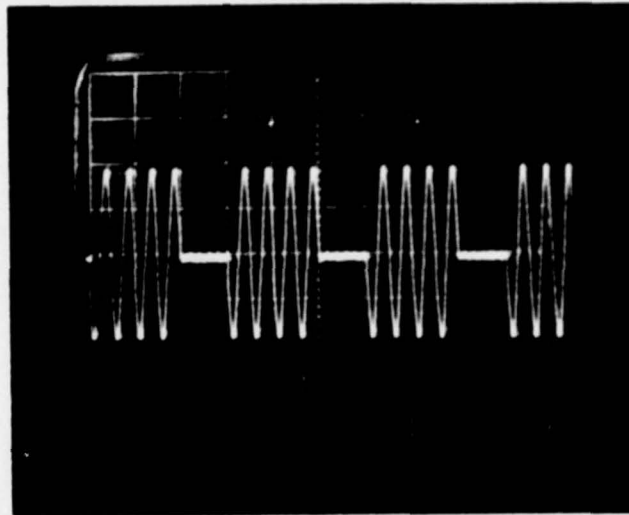

Figure 2. IM SIGNAL MODULATED BY A CONSTANT VOLTAGE.
 $f_c = 200$ kHz, $T_c = 5$ μ s, $j = 4$, $k = 2$,
 $\ell = 6$, $x_0 = 0$, $T_b = 20$ μ s, $T_x = 10$ μ s, and
 $T_s = 30$ μ s.

With the IM signal as described above it is possible to expand it in a trigonometric Fourier series and arrive at a frequency domain representation of the IM signal for DC voltage modulation. The result of this analysis (the details of which are given in Appendix A) is that the spectrum of the IM signal, modulated by a constant voltage, consists of discrete lines at harmonics of the sampling frequency and, for $x_0 = 0$ (i.e., the DC voltage is

judiciously chosen such that the interval between bursts is exactly equivalent to a full number of cycles of the sinusoidal carrier), the principal line in the spectrum occurs at the carrier frequency. Figure 3 is the spectrum produced by the IM signal in Figure 2.

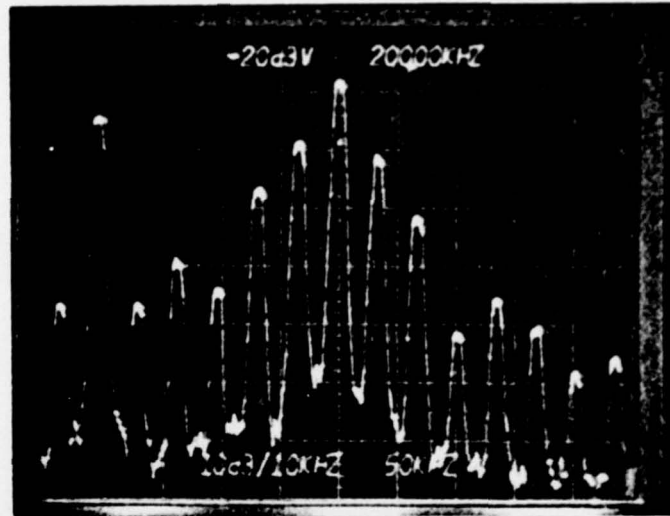

Figure 3. SPECTRUM OF IM SIGNAL MODULATED BY A CONSTANT VOLTAGE. Frequency range of 0 to 450 kHz.

The spectral lines in Figure 3 occur at harmonics of the sampling frequency, in this case 33.3 kHz. This spacing is more easily seen in Figure 4.

For x_0 not equal to zero the magnitude and location of the spectral lines of the IM signal change. For x_0 , not equal to zero the location of the i^{th} spectral line shifts from $\frac{if_c}{l}$ to $\frac{if_c}{l+x_0}$. This is because an increase in x_0 corresponds to a decrease in the sampling frequency. The magnitude of each spectral line for a non-zero x_0

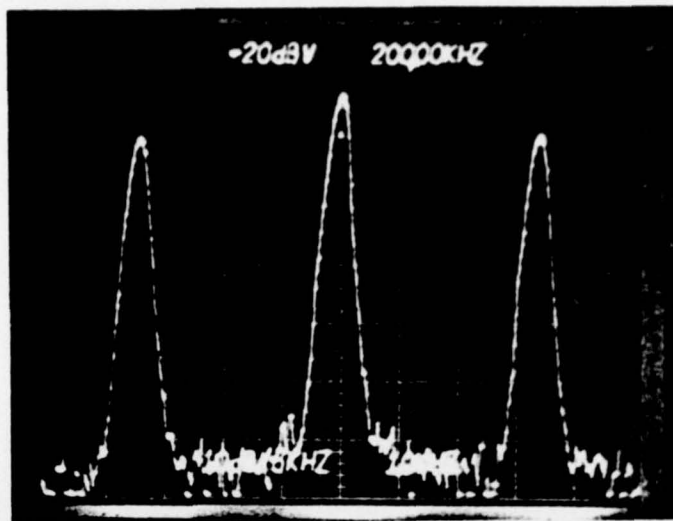

Figure 4. EXPANDED PORTION OF FIGURE 3.
Frequency range of 150 kHz to 250 kHz.

is slightly more complicated to calculate, but the effect is that the line which moves to the left, away from f_c , decreases in magnitude while the line moving to the left, toward f_c , increases in magnitude. This effect is seen by a comparison of Figure 5 with Figure 3. ($x_0 = 0$ in Figure 3 and $x_0 = 0.32$ in Figure 5.) Figure 6 is an expanded portion of Figure 5 and shows the shift in location of the sixth spectral line from 200 kHz to 190 kHz and the shift in location of the seventh spectral line from 233.3 kHz to 221.2 kHz. Therefore, as x_0 is slowly increased toward one, the spectral lines of Figure 6 shift to the left until, with x_0 equal to one, the principal spectral line in the series becomes the seventh and is located at

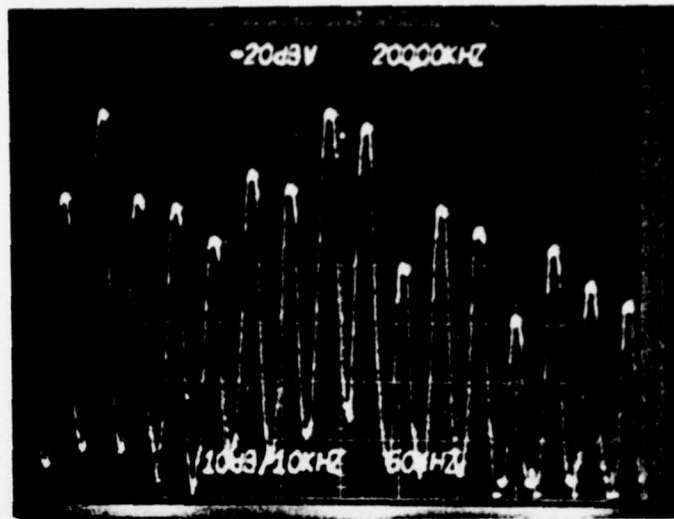

Figure 5. SPECTRUM OF IM SIGNAL MODULATED BY A CONSTANT VOLTAGE WHEN $x_0 \neq 0$.
 $f_c = 200$ kHz, $j = 4$, $k \cong 2$, $l = 6$,
 and $x_0 = 0.32$.

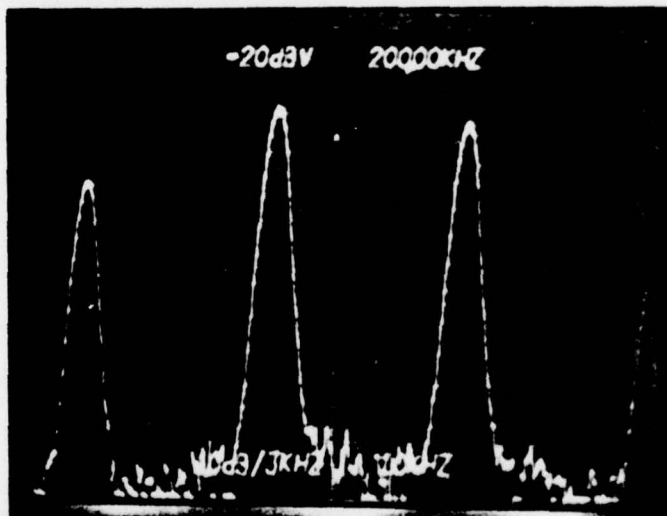

Figure 6. EXPANDED PORTION OF FIGURE 5.
 Frequency range of 150 kHz
 to 250 kHz.

f_c . An x_0 equal to one is equivalent to holding x_0 at zero and increasing l by one. Therefore, increasing l also results in the spectral lines shifting to the left, decreasing in magnitude as they move away from f_c and increasing in magnitude as they move toward f_c . These shifts in frequency of the spectral lines and the changes in their magnitudes has impact upon the demodulation of the IM signal.

IV. INTERVAL MODULATION WITH GENERAL MODULATING WAVEFORMS

For the case of the IM signal modulated by a constant voltage the interval between the bursts of the sinusoidal carrier is $T_x = (k + x_0) T_c$. To include the effect on T_x of the amplitude of a general modulating message waveform $m(t)$, let $x(t) = x_0 + bm(t)$, where b is a constant. Then, for a general $m(t)$, any particular sample of the modulating waveform will produce an interval between bursts of the sinusoidal carrier given by $T_x = (k + x(t)) T_c$. For a general modulating message waveform the IM signal does not lend itself to the Fourier analysis done in the case of the IM signal modulated by a constant voltage. But, if the range of variation in $x(t)$ is small and if the sampling frequency is sufficiently greater than the maximum frequency contained in the message waveform, then adjacent samples of the message waveform are almost equal and a quasi-static approximation to the sampling frequency of $\frac{f_c}{k + x_c}$ can be used.

For a small range of variation of $x(t)$, the spectrum produced by the IM signal appears to be very similar to that which would be produced by a PDM type signal. This similarity becomes apparent by the application of sine wave modulation to T_x . This has the effect of producing sidebands, similar to those which would be seen with frequency

modulation, about each harmonic of the quasi-static sampling frequency. This is almost precisely what would be expected as the frequency spectrum for a PDM signal [Reference 1]. For example, a 4 kHz sine wave modulating waveform produces the IM signal shown in Figure 7.

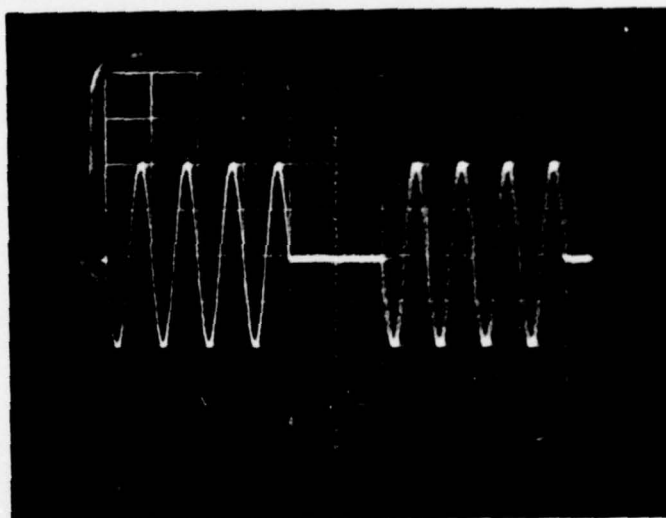

Figure 7. IM SIGNAL MODULATED BY A SINUSOID.
 $f_c = 200 \text{ kHz}$, $j = 4$, $k = 2$, $l = 6$,
 $x_0 = 0$, and $-0.04 \leq x(t) \leq 0.04$
 $(9.8 \text{ } \mu\text{s} \leq T_x \leq 10.2 \text{ } \mu\text{s})$.

This IM signal has the spectrum shown in Figure 8. Visible in Figure 8 are the fifth, sixth, and seventh harmonics (with their associated sidebands) of the quasi-static sampling frequency. Notice that the principal line in the spectrum is at the carrier frequency, $f_c = 200 \text{ kHz}$. Figure 9 is an expanded portion of Figure 8 and shows the FM type sidebands associated with the sixth harmonic of the quasi-static sampling frequency. Since the modulating

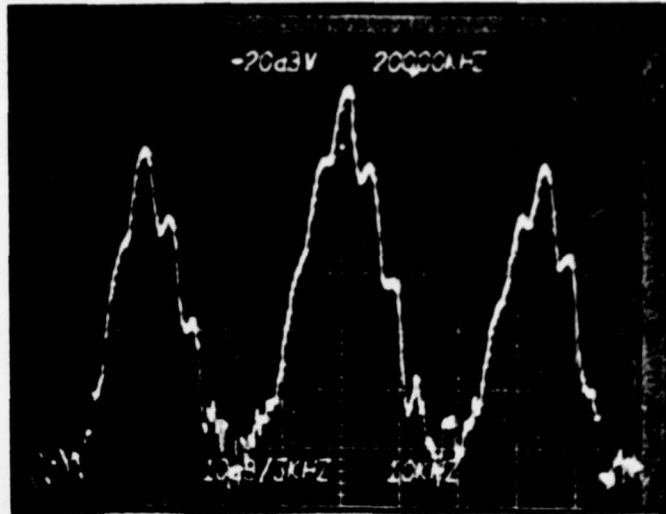

Figure 8. SPECTRUM OF IM SIGNAL OF FIGURE 7.
Frequency range of 150 kHz to 250 kHz.

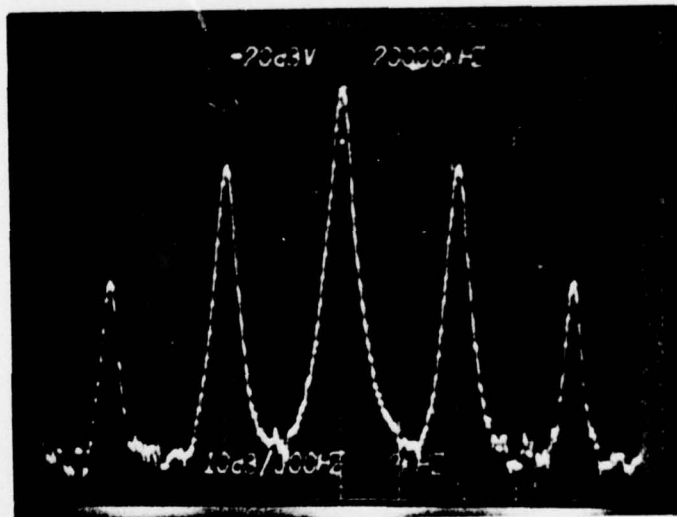

Figure 9. EXPANDED PORTION OF FIGURE 8.
Frequency range of 190 kHz to 210 kHz.

waveform is at 4 kHz, the sidebands are at $200 \text{ kHz} \pm 4 \text{ kHz}$ and $200 \text{ kHz} \pm 8 \text{ kHz}$ ($f_c \pm f_m$ and $f_c \pm 2f_m$). These sidebands are observed to exist about each of the harmonics of the quasi-static sampling frequency.

Figure 10 is an example of the spectrum (centered about the eighth harmonic of the quasi-static sampling frequency) of the IM signal modulated by music.

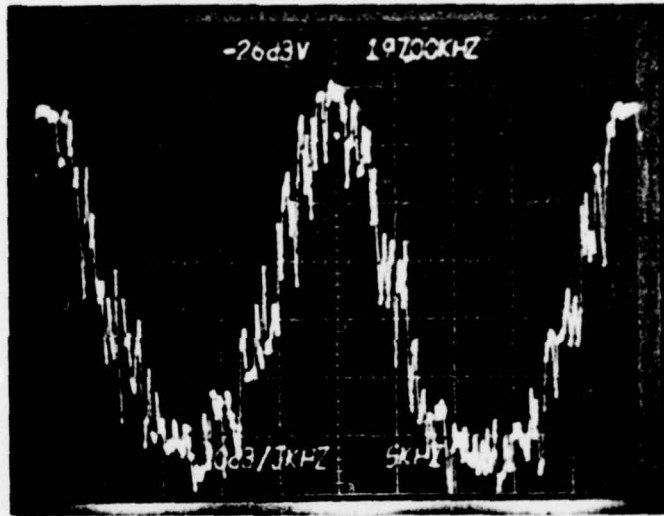
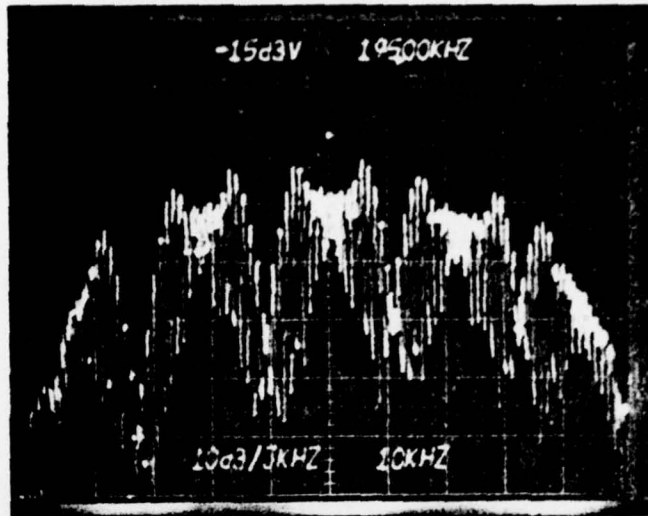
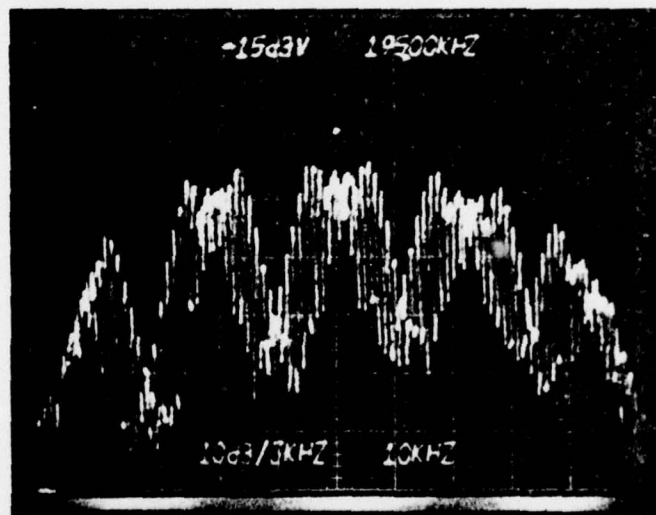

Figure 10. SPECTRUM OF IM SIGNAL MODULATED BY MUSIC.
 Frequency range of 172 kHz to 222 kHz.
 $f_c = 197 \text{ kHz}$, $j = 4$, $k = 4$, $\ell = 8$, $x_0 = 0$,
 and $-0.1 \leq x(t) \leq 0.1$ ($23.5 \mu\text{s} \leq T_x \leq 24.5 \mu\text{s}$).

If the range of variation of $x(t)$ is made large, say ± 0.5 , then the amplitude of the sidebands increases and produces a spectrum, centered about each of the harmonics of the quasi-static sampling frequency, which is similar to a large modulation index FM spectrum. The spectrum about each harmonic resembles the probability density function of the modulating signal. This can be seen in Figure 11.



a. IM SIGNAL MODULATED BY SINE WAVE



b. IM SIGNAL MODULATED BY TRIANGULAR WAVE

Figure 11. SPECTRUM OF IM SIGNAL FOR LARGE AMPLITUDE MODULATING SIGNAL. Frequency range of 145 kHz to 245 kHz. $f_c = 195$ kHz, $j = 4$, $k = 5$, $l = 9$, $x_0 = 0$, and $-0.5 \leq x(t) \leq 0.5$ ($23 \mu s \leq T_x \leq 28.2 \mu s$).

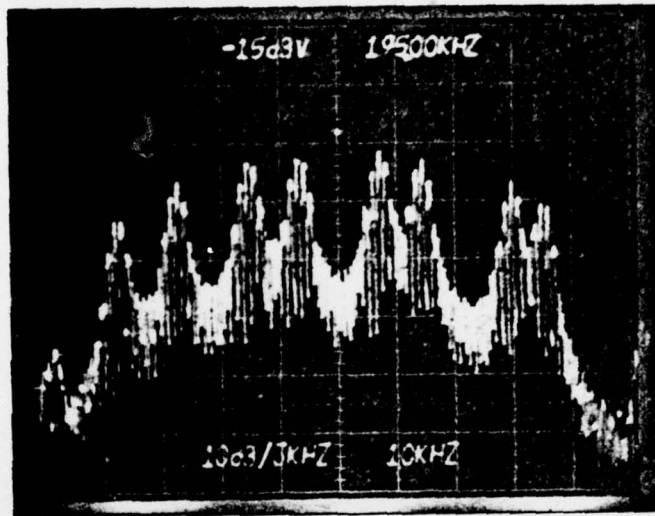

c. IM SIGNAL MODULATED BY SQUARE WAVE

Figure 11

V. INTERVAL MODULATION SIGNAL MODULATOR

The IM signal modulator uses samples of the input message waveform $m(t)$ to determine the length of the interval between the bursts of the sinusoidal carrier. This is accomplished in the following manner: $m(t)$ is sampled and after a delay of T_x seconds, where T_x is proportional to the amplitude of the sampled value of $m(t)$, a burst of j full cycles of the sinusoidal carrier is transmitted. Upon completion of the burst, $m(t)$ is again sampled and the sequence of events repeats. The sampling of $m(t)$ is non-periodic; the length of the burst is fixed while the interval between the bursts is a function of the sampled amplitude of $m(t)$.

The character of the IM signal depends upon several parameters. These parameters include the number of cycles in a burst, the frequency of the sinusoidal carrier comprising the burst, the length of the basic interval between bursts, and the range of variation (due to the amplitude of the modulating signal) of the interval between bursts. For this reason, the IM signal modulator is designed to permit, within certain limits, variation in the IM signal parameters. Figure 12 shows the basic block diagram for the IM signal modulator. Referring to Figure 12, the frequency of the sinusoidal carrier is varied by changing the frequency of the Gated Sinusoidal Burst Generator.

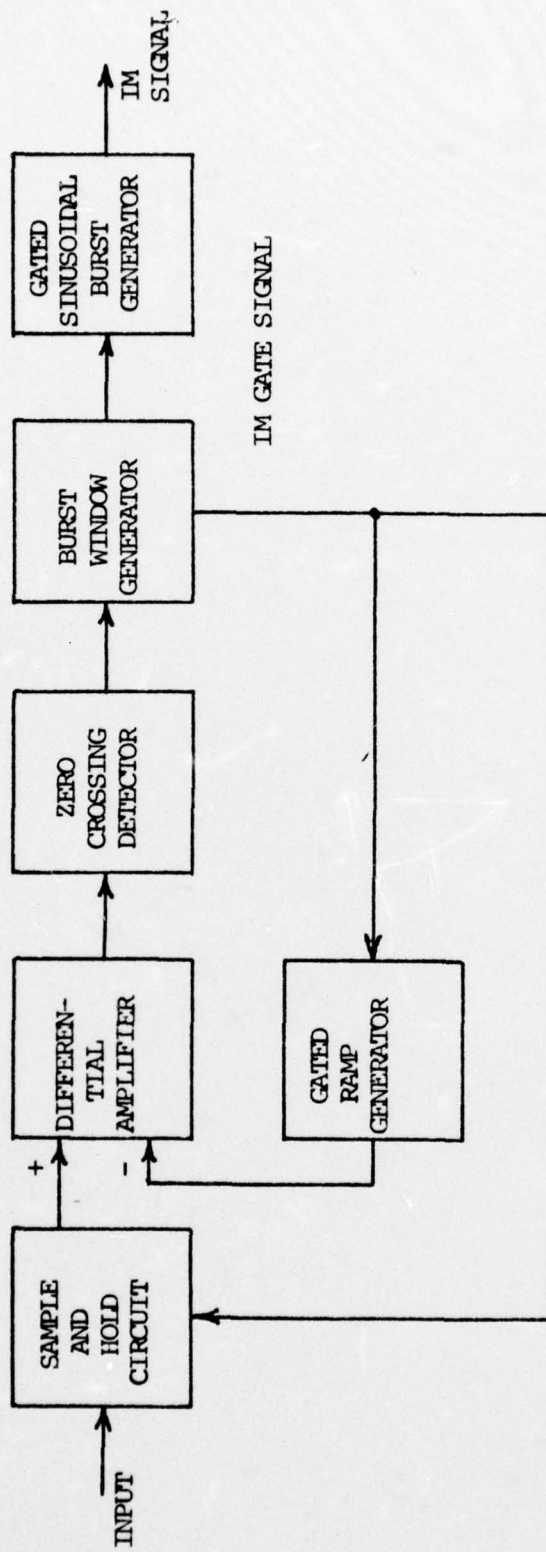

Figure 12. BLOCK DIAGRAM OF THE IM SIGNAL MODULATOR

The number of cycles of the sinusoidal carrier in each burst is controlled by changing the length of the Burst Window Generator. The basic interval between bursts is controlled by changing the slope of the ramp output from the Gated Ramp Generator. And, the range of variation of the interval, due to modulation, is controlled by the amplitude of the modulator's input signal.

Figure 13 is a simplified timing diagram for the IM signal modulator and shows the sequence of events to produce the IM signal. The operation of the modulator is as follows. Coincident with the completion of a burst of the sinusoidal carrier a sample command is issued to the Sample and Hold circuit and the Gated Ramp Generator is turned on. The outputs from the Sample and Hold circuit and the Gated Ramp Generator are fed through a Differential Amplifier having zero volts output when the output of the Sample and Hold circuit is equal to the output of the Gated Ramp Generator. The Zero Crossing Detector following the Differential Amplifier notes the zero crossing and turns on the Burst Window Generator. The Burst Window Generator then gates on the Gated Sinusoidal Burst Generator. The length of the burst from the Gated Sinusoidal Burst Generator is a function of the length of the Interval Modulated Gate signal produced by the Burst Window Generator. The length of the Interval Modulated Gate signal is controlled by a timing sequence, the duration of which is

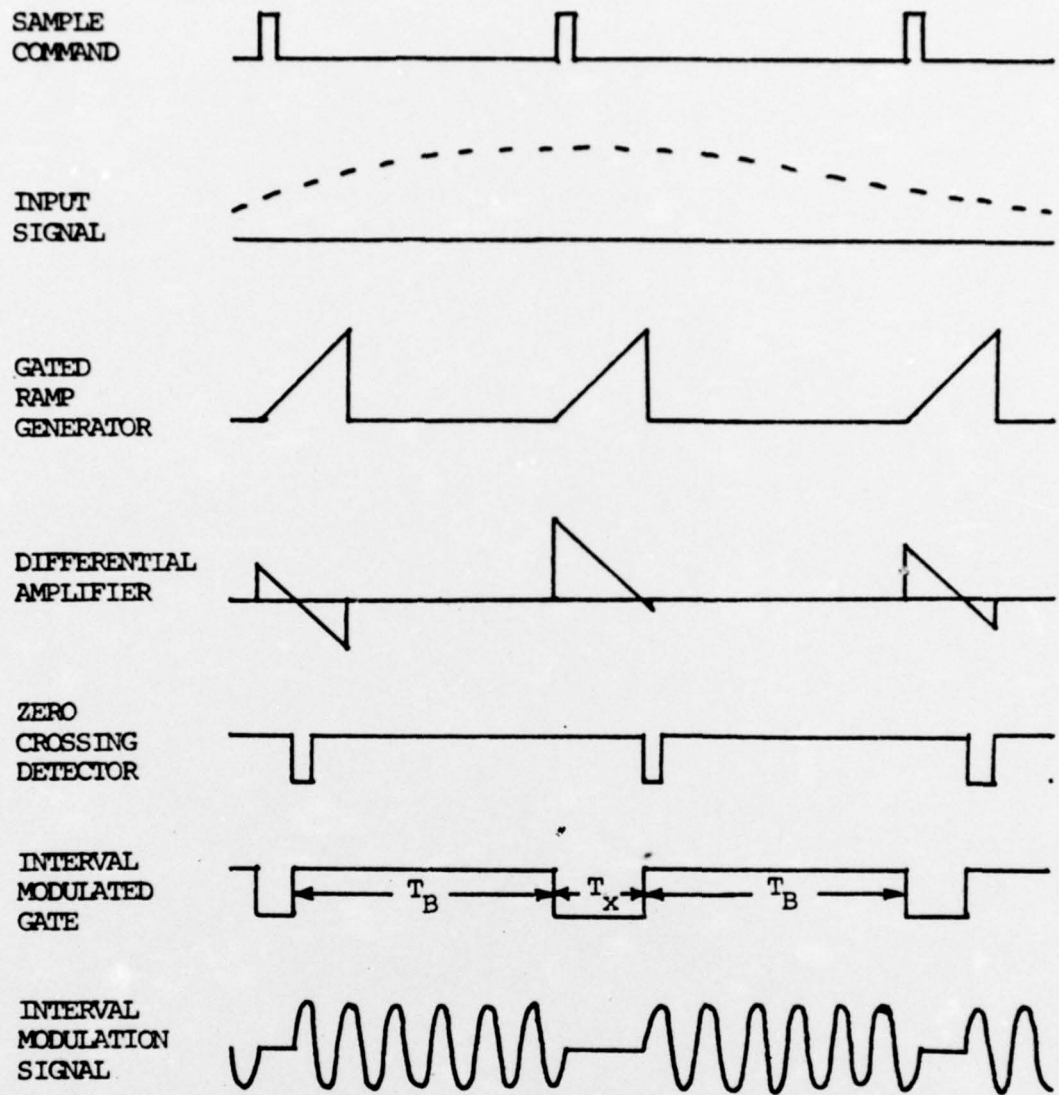

Figure 13. TIMING DIAGRAM OF THE IM SIGNAL MODULATOR

variable. Upon completion of the timing sequence the Interval Modulated Gate signal is turned off, another sample is taken, and the sequence of events repeats. A further description of the operation of the IM signal modulator, along with detailed circuit diagrams and waveforms representative of the logic timing, is contained in Appendix B.

The device used as the Gated Sinusoidal Burst Generator is an Interstate Electronics Corporation F-36 AM/FM Function Generator. The F-36 Function Generator, in its gated mode, produces full cycles of an output sinusoid for an input gate signal and therefore serves to produce the IM signal. The fact that the Interval Modulated Gate signal may have terminated before the completion of the final cycle of the burst is of no consequence because the modulation of the interval between the bursts of the sinusoidal carrier is applied to the location of the start of the burst. This is shown in Figure 14, where the top trace is the Interval Modulated Gate signal and the bottom trace is the IM signal. The IM signal in Figure 14 consists of four cycles of a 200 kHz sinusoidal carrier with a modulation interval of from 9.8 μ s to 10.3 μ s. This range of variation of the modulation interval is produced by a 0.14 volt peak-to-peak sine wave input to the modulator.

The modulator allows for a burst window of from 4 μ s to in excess of 100 μ s and a modulation interval of from

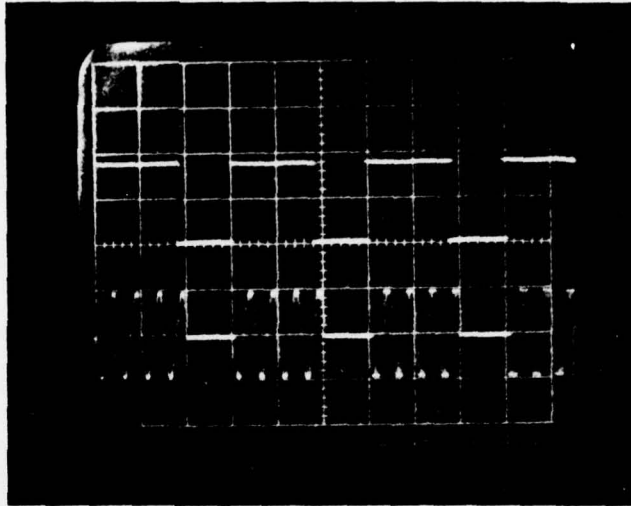

Figure 14. IM GATE SIGNAL AND IM SIGNAL

1 μ s up to 36 μ s. Because the length of the burst window, the basic modulation interval, and the sinusoidal carrier frequency are all related, it is necessary to choose these parameters judiciously. For example, with $x_0 = 0$ and for a small range of variation of $x(t)$, the quasi-static sampling frequency of the modulator is f_c/l (where $l = j+k$). Therefore, to meet the Nyquist rate sampling criterion, l should be no greater than $f_c/2f_m$ where f_m is the maximum frequency in the message waveform. This means that for $f_c = 200$ kHz, and with an audio input to the modulator, l should be no greater than 25.

VI. INTERVAL MODULATION SIGNAL DEMODULATOR

The IM signal demodulator is a phase-locked loop followed by an audio amplifier as shown in block diagram form in Figure 15 (a detailed circuit description is given in Appendix C). The phase-locked loop is set to have a free-running frequency, f_r , close to the frequency of the sinusoidal carrier. (In most instances the sinusoidal carrier frequency is approximately 200 kHz.) A lowpass RC filter is used as the loop filter. This results in a second-order, type-zero loop [Reference 2]. The cutoff frequency of the lowpass RC filter is chosen to be approximately 11 kHz, which is adequate to pass audio frequency signals. But, even with the cutoff frequency of the lowpass RC filter set as low as 450 Hz, demodulation of an audio signal is obtained. This may be due to the fact that the energy in a typical voice spectrum is concentrated in the range of 100 Hz to 600 Hz [Reference 3]. A more likely explanation, however, is the effect of the loop bandwidth on the allowable frequency range for demodulation of the message waveform. For the loop filter with a cutoff frequency of 11 kHz the capture range of the phase-locked loop extends from 158 kHz to 233 kHz. Since the capture range of a phase-locked loop is typically three to four times the loop bandwidth, this implies a loop bandwidth of approximately 20 kHz to 25 kHz. For the loop filter

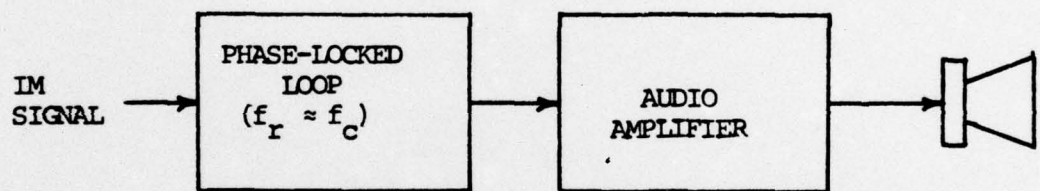
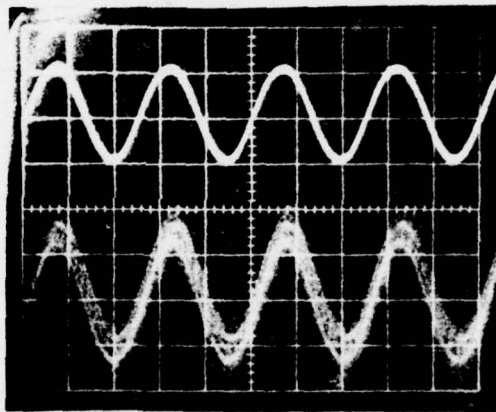

Figure 15. BLOCK DIAGRAM OF THE IM SIGNAL DEMODULATOR

with a cutoff frequency of 450 Hz the capture range of the phase-locked loop extends from 176 kHz to 217 kHz. This implies a loop bandwidth of approximately 10 kHz to 13 kHz. Therefore, both configurations have a loop bandwidth sufficient to pass frequencies in the audio range. Figure 16a is an example of the demodulated output of the phase-locked loop (bottom trace) for a 4 kHz sine wave input to the modulator (top trace) when the cutoff frequency of the loop filter is 450 kHz.



- a. 450 HZ LOOP FILTER CUTOFF FREQUENCY. Scale factors are for the top trace 0.05 v/div. and for the bottom trace 0.01 v/div. The time scale is 100 μ s/div.

Figure 16. OUTPUT OF IM SIGNAL DEMODULATOR FOR SINUSOIDAL MODULATION.

Figure 16b is an example of the demodulated output of the phase-locked loop when the cutoff frequency of the loop filter is 11 kHz. The IM signal parameters for Figure 16

are $f_c = 200$ kHz , $j = 4$, $k = 2$, $\ell = 6$, $x_0 = 0$, and $-0.4 \leq x(t) \leq 0.04$ ($9.8 \mu\text{s} \leq T_x \leq 10.2 \mu\text{s}$).

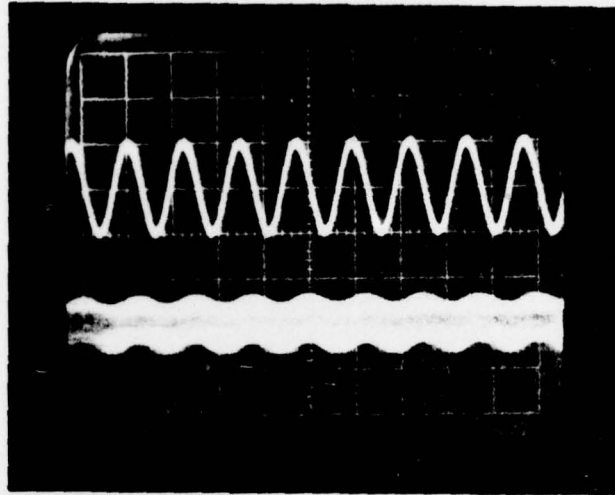

Figure 16. b. 11 kHz LOOP FILTER CUTOFF FREQUENCY. Scale factors for both traces are 0.05 v/div. The time scale is 200 μs /div.

As noted previously, the spectral lines of the IM signal modulated by a constant voltage occur at the harmonics of the quasi-static sampling frequency. And, with the application of a general modulating voltage, sidebands develop about each of these spectral lines. The successful demodulation of the IM signal by the phase-locked loop appears to be due to the ability of the loop to lock to the main spectral line at the carrier frequency (with $x_0 = 0$) and effectively lowpass filter the sidebands surrounding f_c .

For $x_0 = 0$ the principal line in the IM signal spectrum occurs at f_c . The phase-locked loop has no

difficulty in locking to this spectral line. But for a non-zero x_0 there is a change in position and magnitude of the spectral lines at the harmonics of the quasi-static sampling frequency. For example, when $x_0 = 0.5$, these harmonics are centered about f_c and the lines on either side of f_c are of comparable strength. This results in serious problems in demodulation because the phase-locked loop appears unable to lock to one line. Therefore, to ensure that the principal spectral line of the IM signal is at f_c , zero is the choice for x_0 .

As the interval between the bursts of the sinusoidal carrier is increased or decreased, the spectral lines of the IM signal, at the harmonics of the quasi-static sampling frequency, shift to the left or the right respectively. But, since each spectral line carries with it sidebands which contain the modulation information, sweeping the main spectral lines past f_c only causes the phase-locked loop to drop lock on what had been the principal spectral line within the loop's bandwidth and acquire lock on what becomes the new principal spectral line within the loop's bandwidth.

The question now arises as to the allowable range of variation of $x(t)$ for successful demodulation of the IM signal by the phase-locked loop. Sine wave modulation of the IM signal was shown in Figure 7 for $-0.04 \leq x(t) \leq 0.04$. This range of variation of $x(t)$ produces the frequency

spectrum shown in Figures 8 and 9. Note that in Figure 9 the level of the spectral line at f_c is dominant over the sidebands. This range of variation of $x(t)$ results in good demodulation of the IM signal. But, a further increase in the range of variation of $x(t)$ increases the level of the sidebands relative to the level of the carrier frequency component and affects the ability of the phase-locked loop to demodulate the IM signal. For example, when the range of variation of $x(t)$ is increased to $-0.15 \leq x(t) \leq 0.15$ (while all other IM signal parameters are maintained the same as they were for Figure 7) the IM signal (Figure 17a) produces a spectrum which has sidebands whose levels are almost equal to the level of the carrier frequency component. This effect is shown in Figures 17b and 17c.

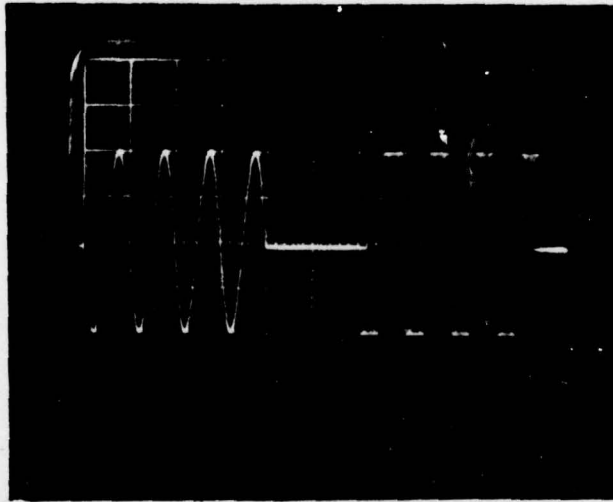

- a. IM SIGNAL. Produced by a 4 kHz sine wave input to modulator. $f_c = 200$ kHz, $j = 4$, $k = 2$, $l = 6$, $x = 0$, and $-0.15 \leq x(t) \leq 0.15$ ($9.25 \mu s \leq T_x \leq 10.75 \mu s$).

Figure 17. EFFECTS OF AN INCREASE IN THE AMPLITUDE OF THE MODULATING SIGNAL.

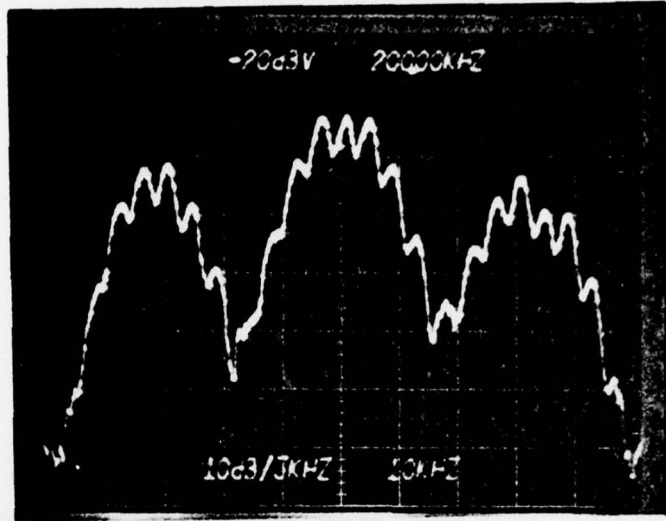

Figure 17. b. SPECTRUM OF a. Frequency range of 150 kHz to 250 kHz.

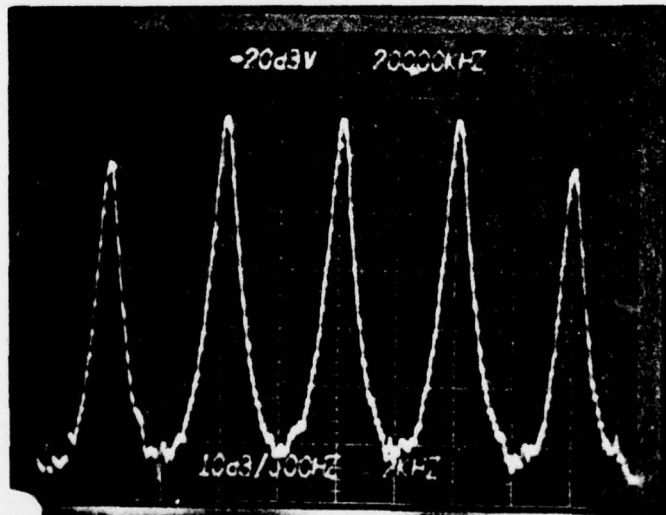
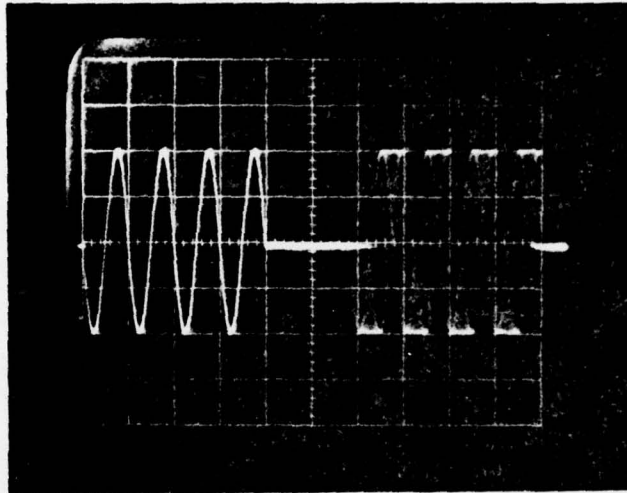

Figure 17. c. EXPANDED PORTION OF b. Frequency range of 190 kHz to 210 kHz.

The point to note here is that this increased range of variation of $x(t)$ results in some distortion of the demodulator's output. Now, if the range of variation of $x(t)$ is further increased to $-0.225 \leq x(t) \leq 0.225$ the IM signal (Figure 18a) produces sidebands about the carrier frequency component which are on a level greater



- a. IM SIGNAL. Produced by a 4 kHz sine wave input to modulator. $f_c = 200$ kHz, $j = 4$, $k = 2$, $l = 6$, $x_0 = 0$, and $-0.225 < x(t) < 0.225$ ($8.875 \mu s \leq T_x \leq 11.125 \mu s$).

Figure 18. EFFECTS OF A FURTHER INCREASE IN THE AMPLITUDE OF THE MODULATING SIGNAL.

than that of the spectral line at f_c . This effect is shown in Figures 18b and 18c. With this large a range of variation of $x(t)$, demodulation of the IM signal by the phase-locked loop is not possible. This is probably because, with the decrease in the level of the carrier



Figure 18. b. SPECTRUM OF a. Frequency range of 150 kHz to 250 kHz.

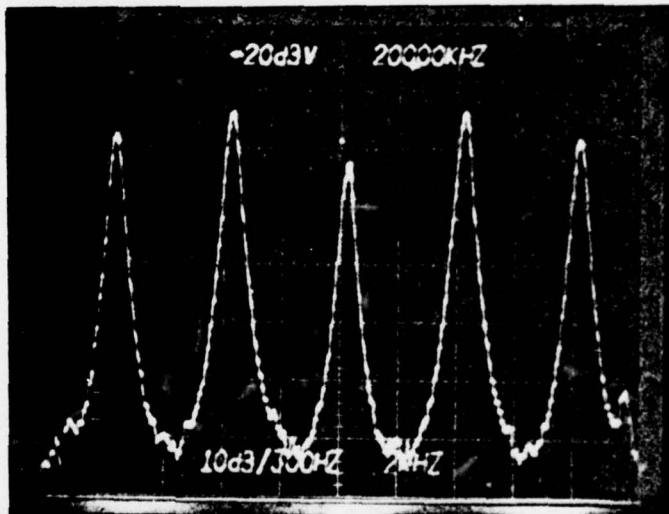

Figure 18. c. EXPANDED PORTION OF b. Frequency range of 190 kHz to 210 kHz.

frequency spectral line relative to the level of the sidebands, the phase-locked loop loses lock on the spectral line at f_c and thereby loses its ability to coherently demodulate the IM signal.

In addition to the effect of the range of variation of $x(t)$ on the phase-locked loop's ability to demodulate the IM carrier signal, consideration must be given to the choice of j and l . If j is small as compared to l then the magnitude of the carrier component at f_c will be decreased relative to the magnitude of the carrier component if j were close to l . Thus, for small j , as compared to l , slight degradation in the quality of the demodulated signal is observed. But, of more significance than the choice of j is the choice of l . For a given carrier frequency the choice of l determines the quasi-static sampling frequency of the modulator (f_c/l) and hence the spacing between the spectral lines of the IM signal. For example, for $f_c = 200$ kHz and $l = 20$, the spectral components occur every 10 kHz. This implies a quasi-static sampling frequency of 10 kHz. So, if a 5 kHz sine wave were then used to modulate the IM signal the resulting sidebands surrounding each of the spectral lines of the quasi-static sampling frequency would overlap. This is the familiar problem of aliasing. Therefore, successful demodulation of the 5 kHz sine wave requires that either the carrier frequency be increased or that

l be decreased. For a carrier frequency of 200 kHz and for audio input to the modulator, reasonable choices for j and l are $j = 4$ and $l = 6$. This gives a quasi-static sampling frequency of 33.3 kHz and results in excellent demodulation of audio signals.

VII. SUMMARY AND RECOMMENDATIONS

Interval Modulation (IM) of a sinusoidal carrier is a possible means of conveying the information of a message waveform. Both the modulator and the demodulator for the IM signal are designed to permit analysis and demonstration of this technique for modulating signals in the audio frequency range. It should be possible to extend the techniques utilized herein to permit IM of message waveforms of higher frequencies. To do this might require the use of faster operational amplifiers in the modulator and the use of a phase-locked loop with a higher free-running frequency in the demodulator.

The frequency spectrum of the IM signal consists of distinct frequency bands exhibiting a harmonic relation to the quasi-static sampling frequency. This spectrum closely resembles that of a PDM type signal. Therefore, it may be possible to gain further insight into the IM signal by performing a detailed analysis of the IM signal in a manner similar to that utilized in the analysis of PDM signals.

For the communication of the information in the modulating message waveform, it appears that phase-locked loop used as the IM signal demodulator uses only one spectral region (that associated with the sidebands of the carrier frequency). Therefore, it may be possible to bandpass

filter the IM signal (with a filter of adequate bandwidth to pass twice the maximum frequency in the message waveform) such that only the spectral region associated with the carrier frequency is utilized in transmission.

Successful demodulation of the IM signal requires that the quasi-static sampling frequency be at least twice the maximum frequency contained in the message waveform and that the range of variation of the modulation interval be small as compared to the period of the sinusoidal carrier. With these requirements met it appears the phase-locked loop demodulates the IM signal by locking to the spectral line at the carrier frequency and lowpass filtering the modulation sidebands surrounding the spectral line at the carrier frequency. The lowpass filtering action of the phase-locked loop is most probably determined by the loop bandwidth. This leads to the conclusion that the loop bandwidth should be sufficient to pass twice the maximum frequency contained in the message waveform. But, it should not be so large as to encompass the sidebands associated with other harmonics of the quasi-static sampling frequency. The validity of these conclusions could be established with further investigation.

The merit of IM will ultimately be determined by its capabilities and its limitations as compared to other forms of modulation. Any comparison of IM with other forms of modulation will lead to the investigation of the required signal-to-noise ratio for demodulation of the IM signal.

In conclusion, the method presented in this work for the generation and detection of IM signals is not considered to be the only possible method, but is a method which demonstrates the feasibility of IM as a modulation technique.

APPENDIX A: CHARACTERIZATION OF THE INTERVAL MODULATION SPECTRUM FOR DC MODULATING WAVEFORMS

The IM signal modulated by a constant voltage is periodic with period T_s and may be expanded as a trigonometric Fourier series. Denoting the IM signal by $s(t)$, then:

$$s(t) = C_0 + \sum_{i=1}^{\infty} A_i \cos(i\omega_s t) + \sum_{i=1}^{\infty} B_i \sin(i\omega_s t)$$

where

$$C_0 = \frac{1}{T_s} \int_t^{t+T_s} s(t) dt$$

$$A_i = \frac{2}{T_s} \int_t^{t+T_s} s(t) \cos(i\omega_s t) dt, \quad i = 1, 2, 3, \dots$$

$$B_i = \frac{2}{T_s} \int_t^{t+T_s} s(t) \sin(i\omega_s t) dt, \quad i = 1, 2, 3, \dots$$

and

$$\omega = \frac{2\pi}{T_s}.$$

This results in the following representation for the IM signal modulated by a constant voltage:

$$s(t) = C_0 + \sum_{i=1}^{\infty} A_i \cos\left[\frac{2\pi i f_c t}{\ell + x_0}\right] + \sum_{i=1}^{\infty} B_i \sin\left[\frac{2\pi i f_c t}{\ell + x_0}\right]$$

where

$$C_0 = 0$$

$$A_i = -\frac{1}{2\pi} \left\{ \frac{1}{\ell + x_0 + i} \left[\cos\left(2\pi j \frac{\ell + x_0 + i}{\ell + x_0}\right) - 1 \right] + \frac{1}{\ell + x_0 - i} \left[\cos\left(2\pi j \frac{\ell + x_0 - i}{\ell + x_0}\right) - 1 \right] \right\}, \quad i = 1, 2, 3, \dots$$

$$B_i = -\frac{1}{2\pi} \left\{ \frac{1}{\ell + x_0 + i} \left[\sin\left(2\pi j \frac{\ell + x_0 + i}{\ell + x_0}\right) \right] - \frac{1}{\ell + x_0 - i} \left[\sin\left(2\pi j \frac{\ell + x_0 - i}{\ell + x_0}\right) \right] \right\}, \quad i = 1, 2, 3, \dots$$

and where

f_c = the sinusoidal carrier frequency

T_s = the sampling period

j = the number of cycles of the sinusoidal carrier in the burst ($j = 1, 2, 3, \dots$)

ℓ = the equivalent number of full cycles of the sinusoidal carrier in the burst and the modulation interval combined ($\ell = j + k$ where $k = 0, 1, 2, \dots$)

x_0 = that fraction of a cycle of the sinusoidal carrier which completes the modulation interval ($0 \leq x_0 \leq 1$).

APPENDIX B: CIRCUIT DESCRIPTION OF INTERVAL
MODULATION SIGNAL MODULATOR

The IM signal modulator contains a mixture of linear and TTL integrated circuits and for that reason ± 5 V dc is used as the power supply for the circuit. The modulator consists of a Sample and Hold circuit (Figure B.1), a Gated Ramp Generator (Figure B.2), a Differential Amplifier (Figure B.3), a Zero Crossing Detector (Figure B.4), an Interval Modulated Gate Generator (Figure B.5), a Burst Window Timing circuit (Figure B.6), and a Gated Sinusoidal Burst Generator (Figure B.7).

The message waveform which produces the modulation of the IM signal is applied to the input of the Sample and Hold circuit. A nominal voltage range for the message waveform is 50 mV to 1000 mV peak-to-peak, centered about zero (the range of amplitude of the message waveform controls the range of variation of $x(t)$). With no input to the Sample and Hold circuit the modulator free-runs and produces the Interval Modulated Gate signal. But, when power is initially applied to the modulator it is often necessary to "kick" the Burst Window Timing circuit to initiate a sample of the input signal. This is due to the fact that the modulator is designed as a closed loop timing chain; the completion of the burst window triggers a sample of the input, the sample of the input determines the time

until the initiation of the next burst window and, the completion of the next burst window again triggers a sample of the input. Therefore, to initialize the modulator it is only necessary to disconnect pin 5, of the last one-shot in the Burst Window Timing circuit, from +5 V and momentarily connect it to ground. This action produces a negative going edge which triggers the one-shot in the Sample and Hold circuit and also clocks high the Q output of the JK flip-flop used to produce the Interval Modulated Gate signal. Coincident with Q "high", \bar{Q} is "low" and it is \bar{Q} which is used to gate "on" the Gated Ramp Generator. The modulator circuit is now set in motion with a sample of the input signal on one input to the Differential Amplifier and an increasing ramp signal from the Gated Ramp Generator on the other. To allow for an input to the modulator which is centered about zero, the ramp starts from -3 V. The 50 k Ω potentiometer on the Gated Ramp Generator can be varied to adjust the slope of the ramp and thereby change the basic interval between bursts. The output of the Differential Amplifier, crossing through zero, indicates that the ramp has reached the level of the sampled input signal. The zero crossing by the Differential Amplifier's output is noted by the Zero Crossing Detector and produces, at the output of the Zero Crossing Detector, a transition from a "one" level to a "zero" level. The "zero" level from the Zero Crossing Detector is applied

to the "clear" of the JK flip-flop used to produce the Interval Modulated Gate signal. This terminates the modulation interval by forcing the Q output of the flip-flop "low" and the \bar{Q} output "high". Logically the \bar{Q} output would be used as the gate for the Gated Sinusoidal Burst Generator. But, because of the manner in which the IEC F-36 AM/FM Function Generator works in "Gated Mode", the Q output is used as the Interval Modulated Gate signal to control the IEC F-36 AM/FM Function Generator and produce the IM signal. Therefore, Q "low" turns on the IM signal. Now, since \bar{Q} acts as the gate for the Gated Ramp Generator, the ramp is turned off and returns to -3 V. The ramp, in returning to -3 V, produces another zero crossing (in the opposite direction) of the output of the Differential Amplifier. This returns the output of the Zero Crossing Detector "high" and removes the "clear" signal from the flip-flop used to produce the Interval Modulated gate signal. This leaves the flip-flop free to receive the "clock" signal to terminate the burst.

When the Zero Crossing Detector "clears" the Burst Window Generator's flip-flop the generation of the delay T_x between two bursts has been completed. The length of T_x has then been determined by the slope of the ramp from the Gated Ramp Generator (which is set but variable) and by the amplitude of the sampled input signal.

With the "clearing" of the Burst Window Generator's flip-flop, the Q output of the flip-flop goes "low". It is this negative transition from Q which is used to trigger the first one-shot in the Burst Window Timing circuit. The first one-shot produces, as does the second one-shot in the Burst Window Timing circuit, a pulse of fixed length (whose length can be adjusted by changing the setting of each one-shot's 50 k Ω potentiometer). The trailing edge of the pulse from the first one-shot triggers a pulse from the second one-shot. The trailing edge of the pulse from the second one-shot signifies the end of the burst window by "clocking" the Interval Modulated Gate Generator's flip-flop (which in turn removes the gate from the Gated Sinusoidal Burst Generator and also gates on the Gated Ramp Generator) and by triggering the one-shot in the Sample and Hold circuit. With the initiation of a new sample, the sequence of events repeats.

Figures B.8 through B.12 are waveforms representative of the above description of the modulator's timing logic.

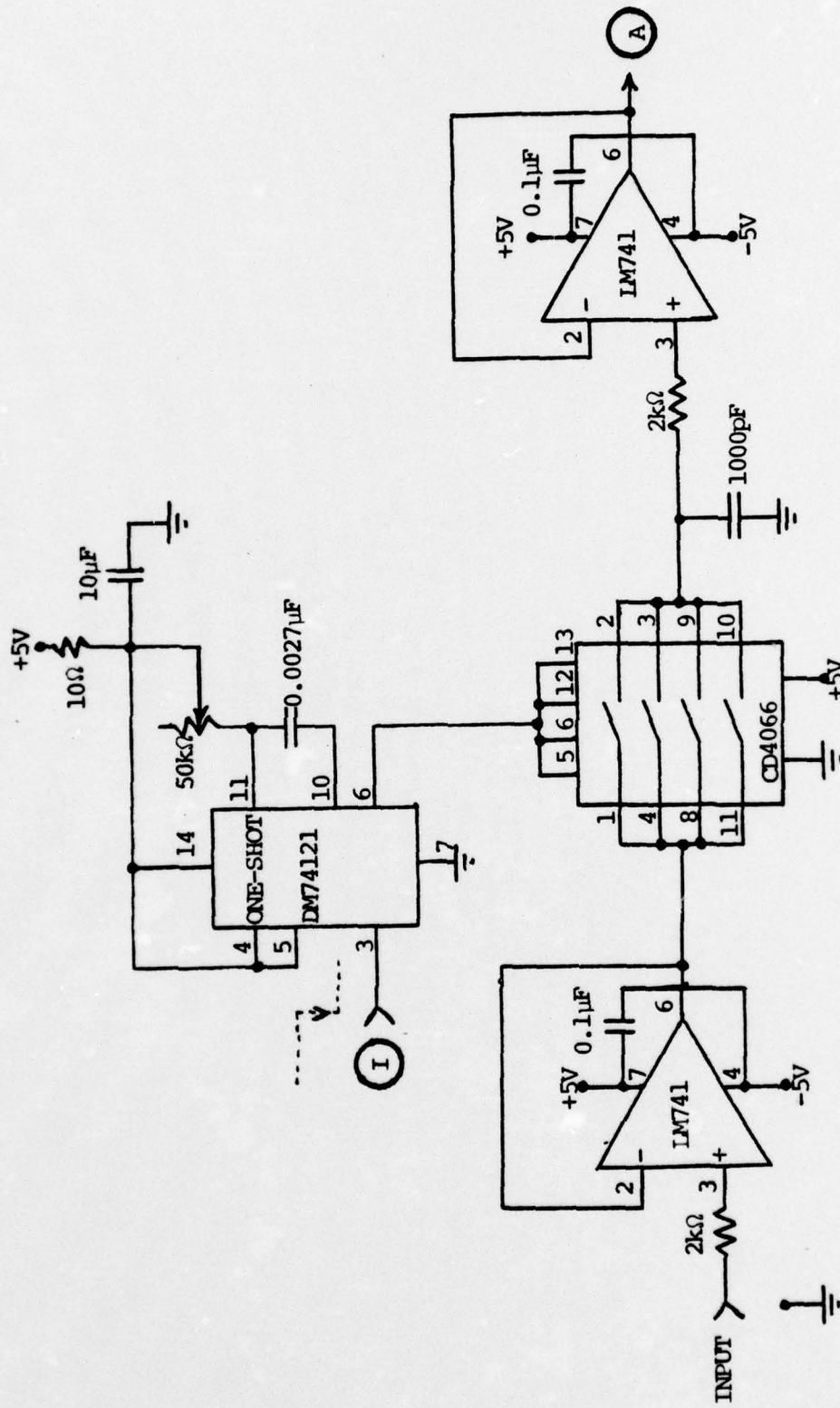

Figure B.1. SAMPLE AND HOLD CIRCUIT

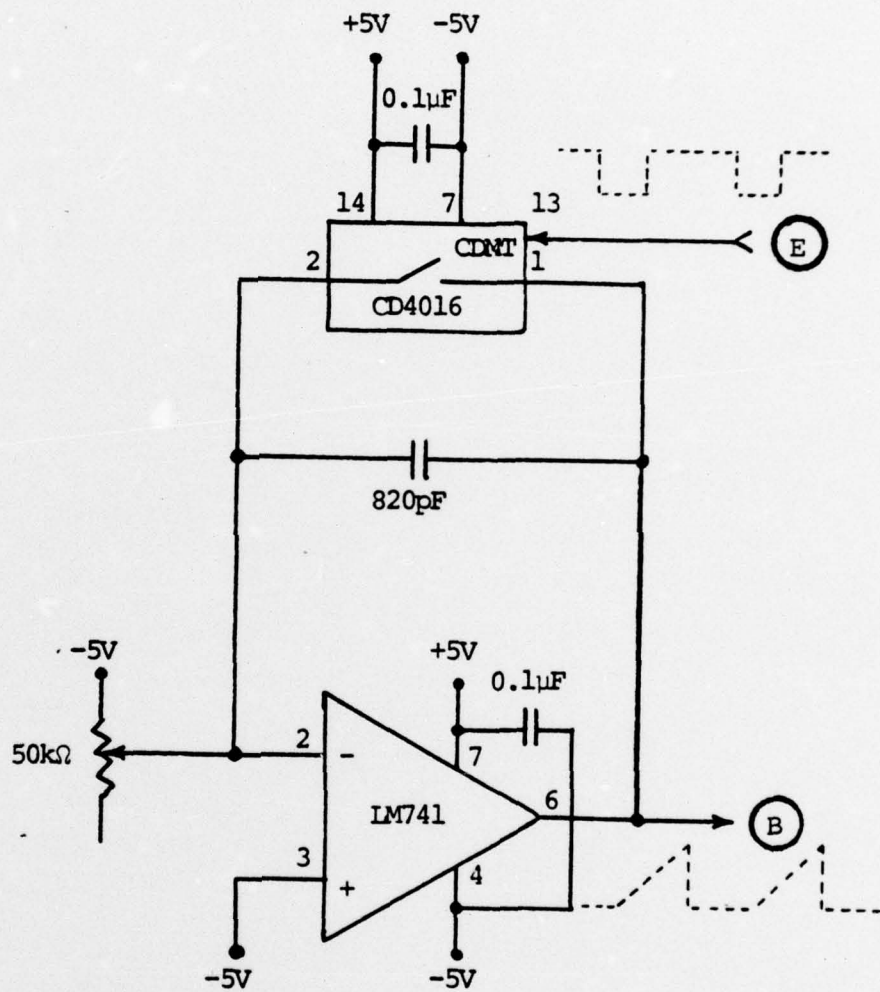

Figure B.2. GATED RAMP GENERATOR CIRCUIT

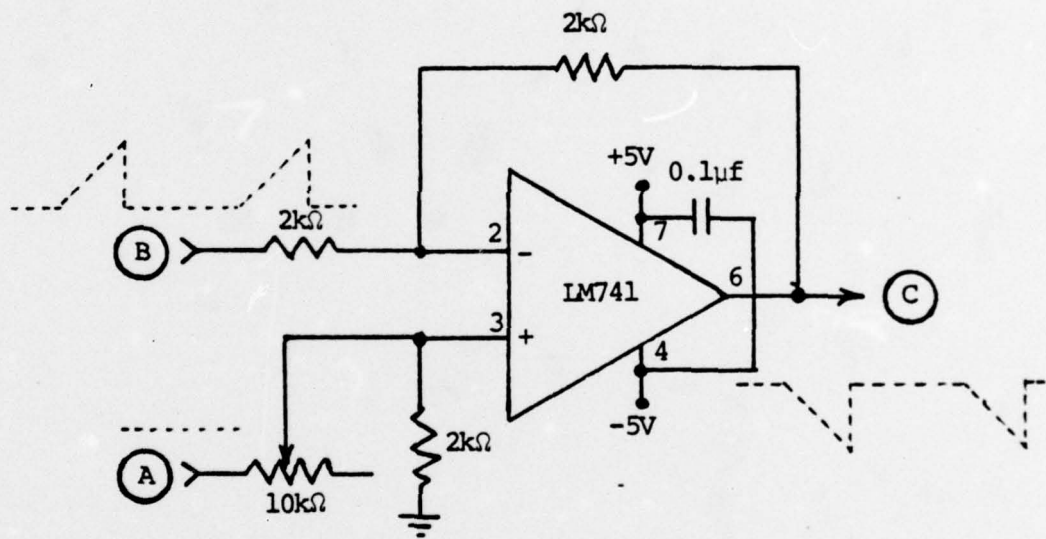

Figure B.3. DIFFERENTIAL AMPLIFIER CIRCUIT

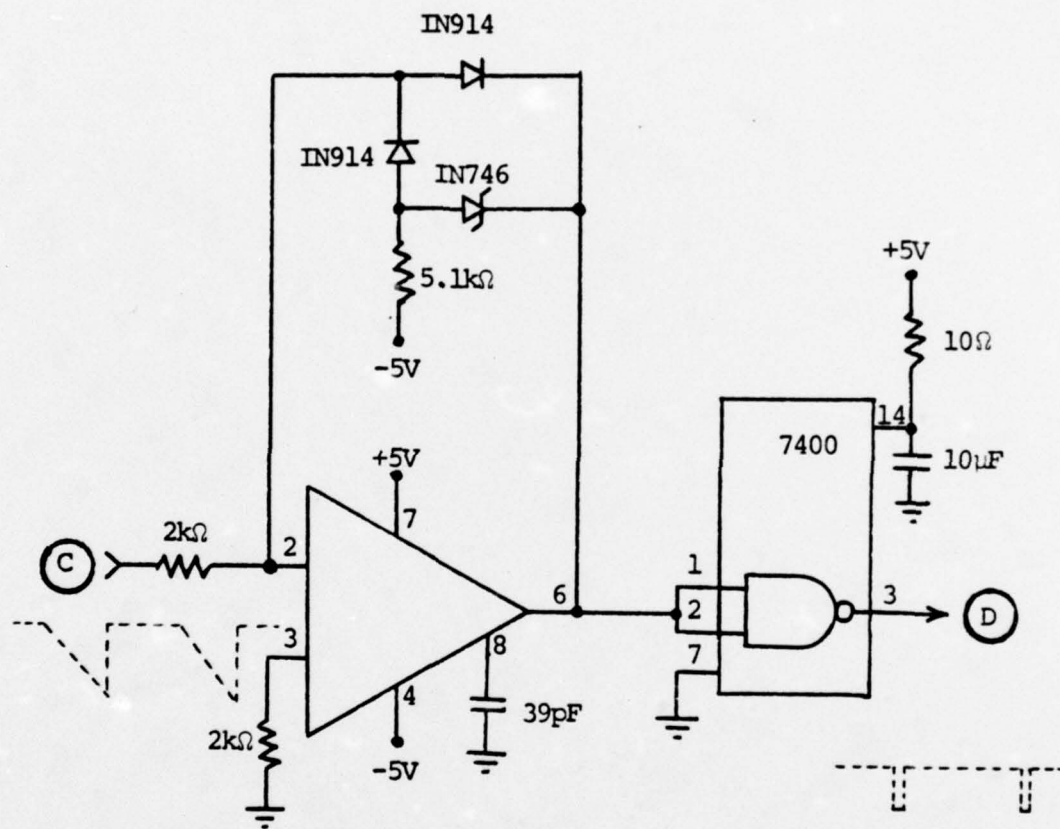

Figure B.4. ZERO CROSSING DETECTOR CIRCUIT

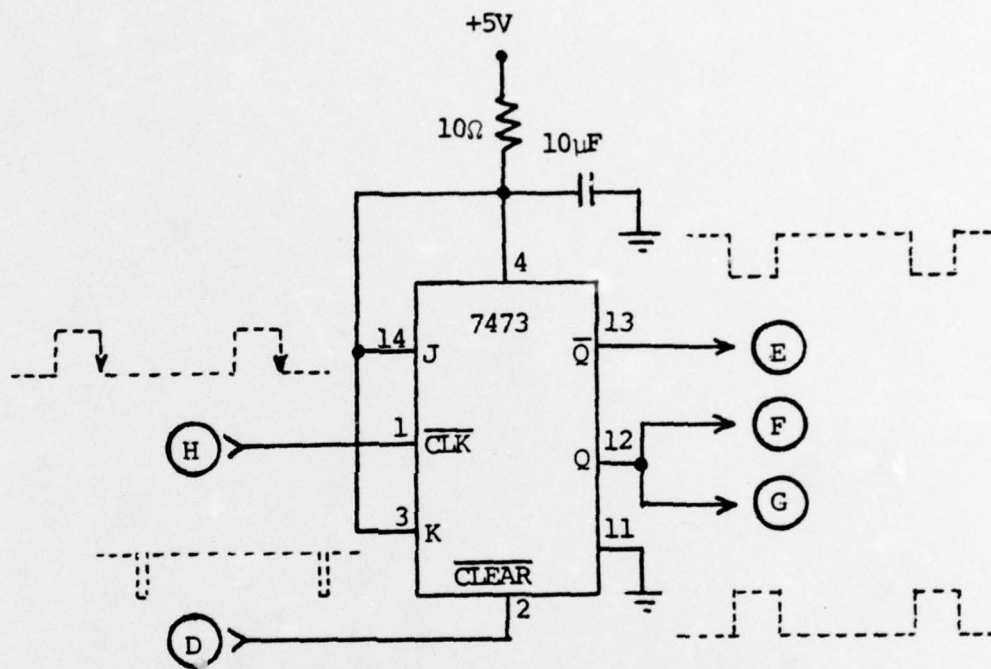

Figure B.5. INTERVAL MODULATED GATE GENERATOR CIRCUIT

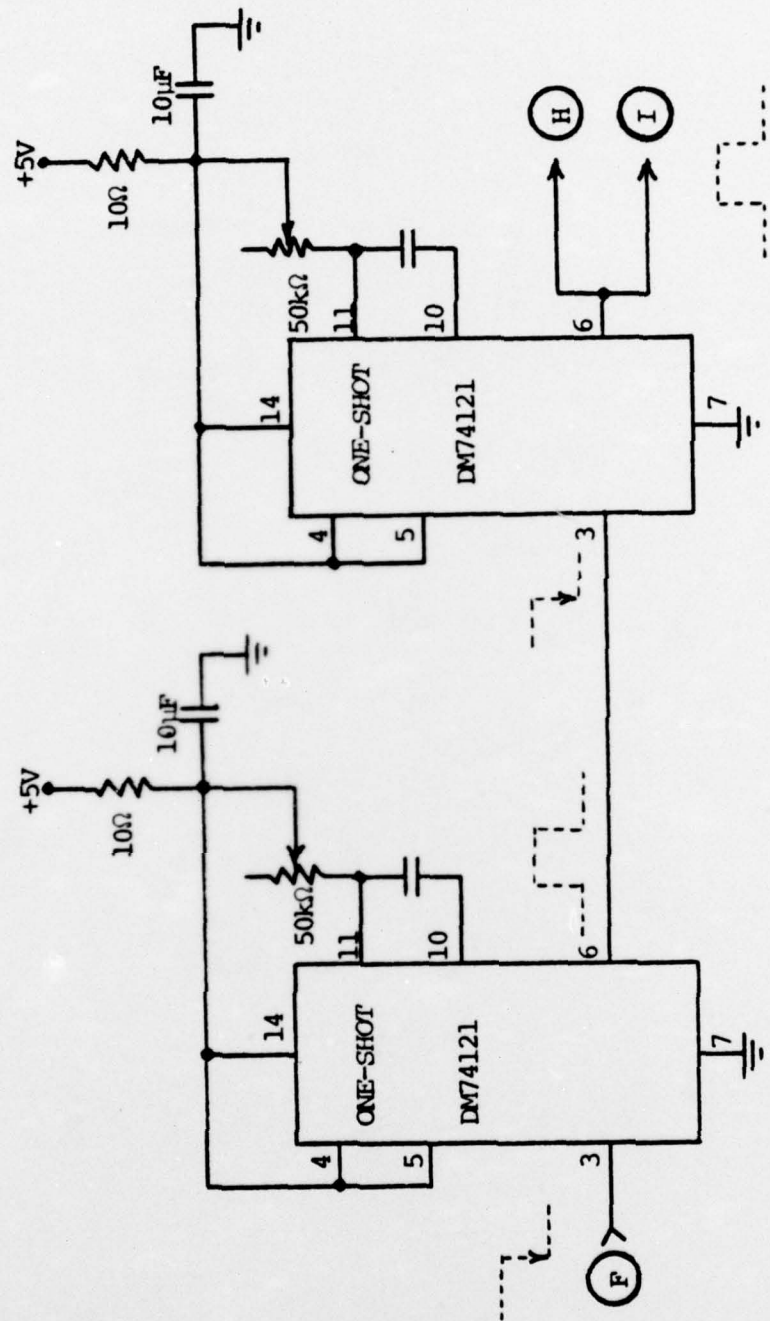

Figure B.6. BURST WINDOW TIMING CIRCUIT

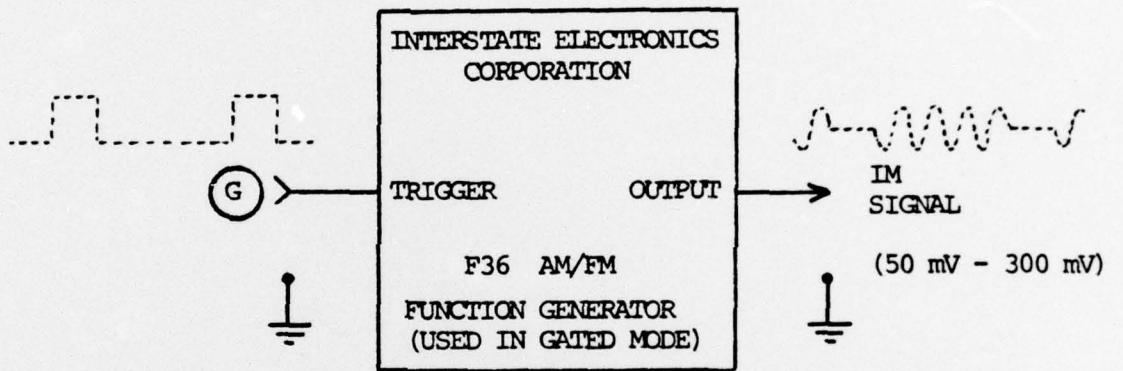
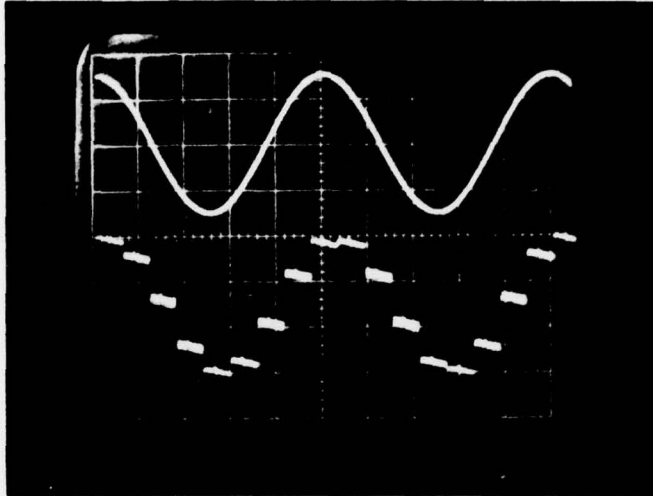

Figure B.7. GATED SINUSOIDAL BURST GENERATOR



Top Trace: 4 kHz sine wave input to modulator.
(20 mV/div., 50 μ s/div.)

Bottom Trace: Output from Sample and Hold circuit.
(20 mV/div., 50 μ s/div.)
Sampling rate of approximately 40
kHz ($24.7 \mu\text{s} < T_s < 25.3 \mu\text{s}$).
IM signal parameters: $f = 200$ kHz,
 $j = 4$, $l = 5$, $x = 0$, and
 $-0.06 < x(t) < 0.06$
($4.7 \mu\text{s} \leq T_x \leq 5.3 \mu\text{s}$).

Figure B.8. SINE WAVE INPUT TO MODULATOR AND
OUTPUT OF SAMPLE AND HOLD CIRCUIT

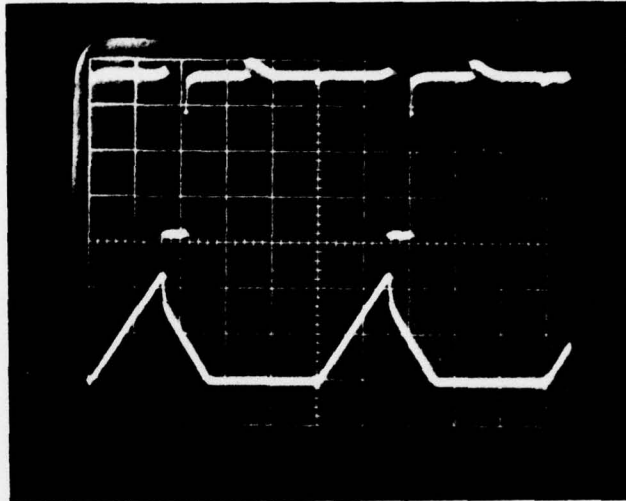

Top trace: Output from Zero Crossing Detector.
(1 V/div., 5 μ s/div.)

Bottom trace: Output from Gated Ramp Generator.
(1 V/div., 5 μ s/div.)

Figure B.9. GATED RAMP GENERATOR TRIGGERING
ZERO CROSSING DETECTOR

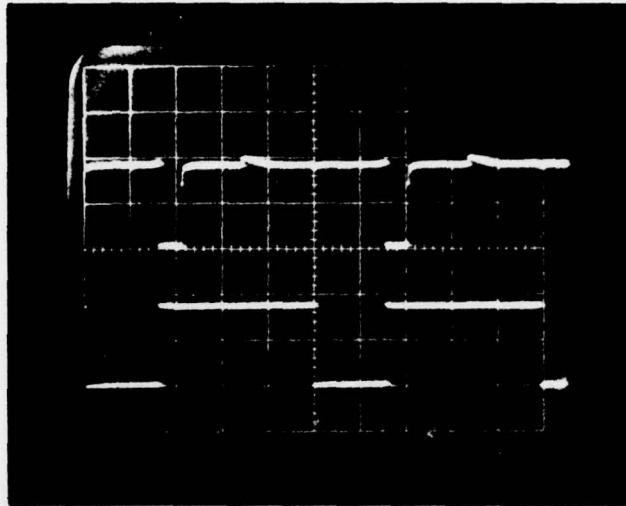

Top trace: Output from Zero Crossing Detector.
(2 V/div., 5 μ s/div.)

Bottom trace: Output from Interval Modulated
Gate Generator.
(2 V/div., 5 μ s/div.)

Figure B.10. ZERO LEVEL FROM ZERO CROSSING DETECTOR
TERMINATING MODULATION INTERVAL AND
INITIATING BURST WINDOW

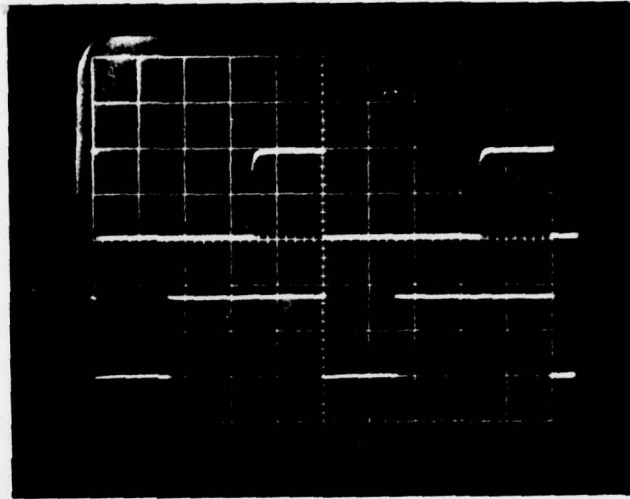

Top trace: Output from final one-shot in Burst Window Timing Circuit.
(2 V/div., 5 μ s/div.)

Bottom trace: Output from Interval Modulated Gate Generator.
(2 V/div., 5 μ s/div.)

Figure B.11. TRAILING EDGE OF FINAL ONE-SHOT IN BURST WINDOW TIMING CIRCUIT TERMINATING BURST WINDOW AND INITIATING MODULATION INTERVAL

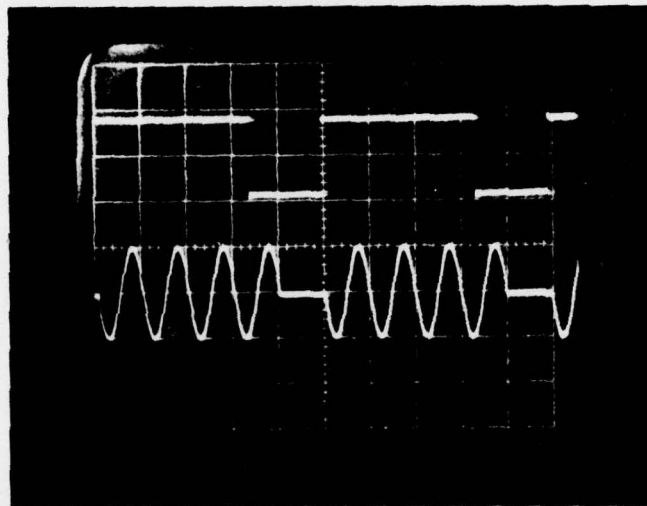

Top trace: IM Gate Signal.
(2 V/div., 5 μ s/div.)

Bottom trace: IM Signal.
(0.1 V/div., 5 μ s/div.)

Figure B.12. IM GATE SIGNAL AND IM SIGNAL.

APPENDIX C: CIRCUIT DESCRIPTION OF INTERVAL
MODULATION SIGNAL DEMODULATOR

The IM signal demodulator consists of an IC phase-locked loop (Figure C.1) and an audio amplifier (Figure C.2). The phase-locked loop utilizes ± 5 V dc for power and the audio amplifier utilizes +12 V dc. The phase-locked loop accepts ac coupled input signals in the range of 80 mV to 300 mV peak-to-peak. The output from the phase-locked loop is ac coupled to the input of the audio amplifier.

Referring to Figure C.1, the phase-locked loop is set to have a free-running frequency f_r of approximately 200 kHz. The free-running frequency is determined by the RC combination on pins 8 and 9. The loop filter consists of an internal $3.6 \text{ k}\Omega$ resistor and an external $0.0039 \text{ }\mu\text{F}$ capacitor. This produces a lowpass cutoff frequency of approximately 11 kHz for the loop filter. Replacing the $0.0039 \text{ }\mu\text{F}$ capacitor with a $0.047 \text{ }\mu\text{F}$ capacitor changes the cutoff frequency of the loop filter to approximately 450 Hz.

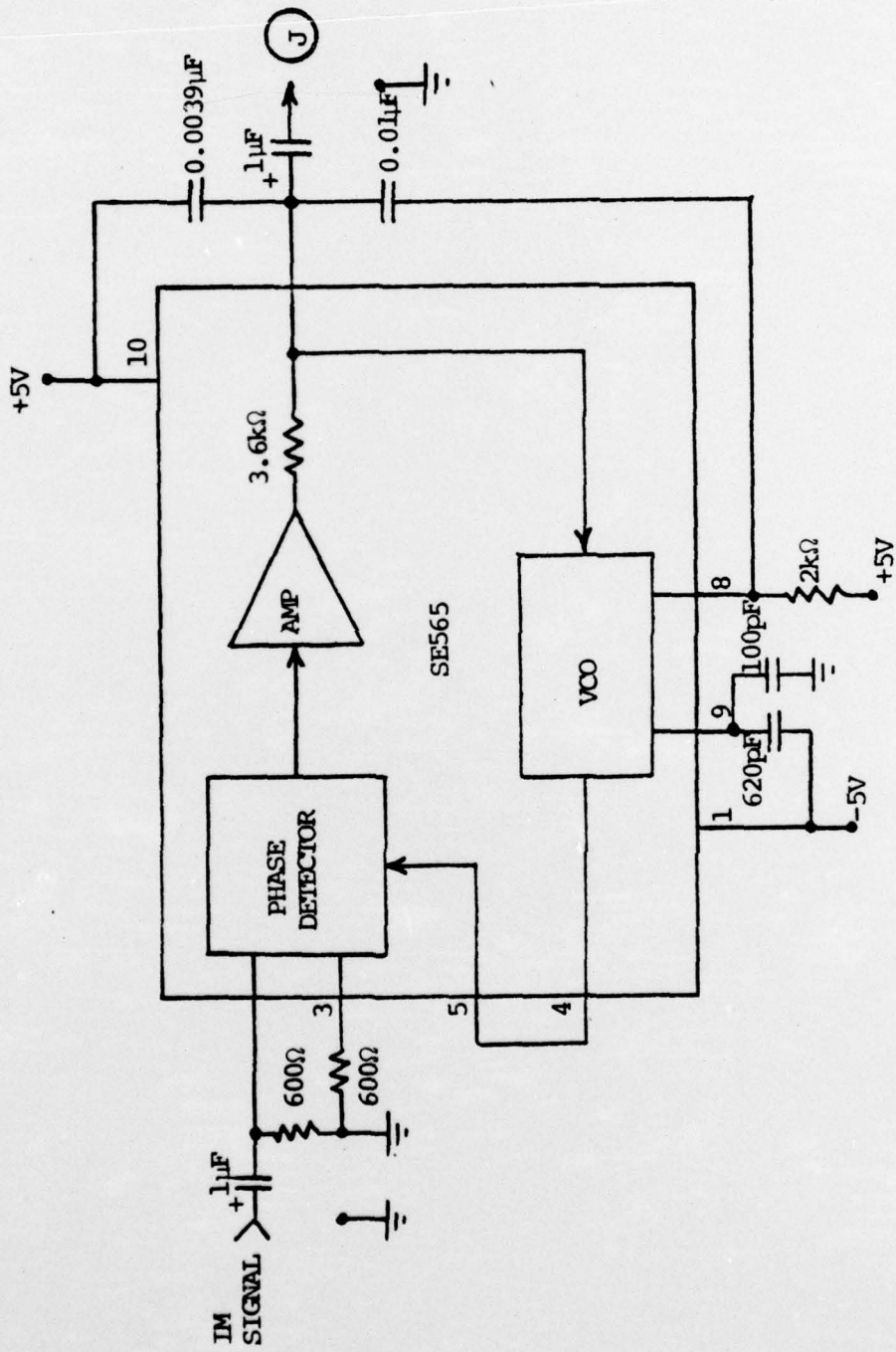

Figure C.1. PHASE-LOCKED LOOP CIRCUIT

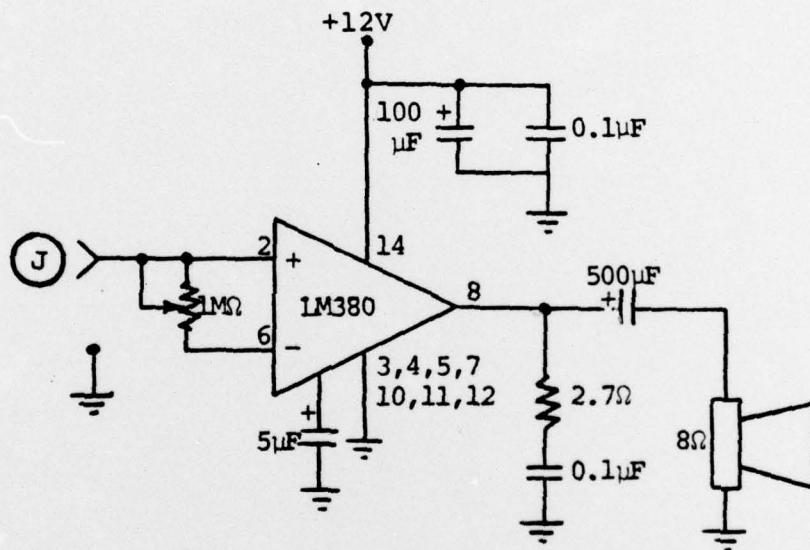

Figure C.2. AUDIO AMPLIFIER CIRCUIT

LIST OF REFERENCES

1. Taub, H. and Shilling, D.L., Principles of Communication Systems, p. 183-185, McGraw-Hill, Inc., 1971.
2. Klapper, J. and Frankle, J.T., Phase-Locked and Frequency-Feedback Systems, p. 85-86, Academic Press, 1972.
3. Carlson, A.B., Communication Systems, p. 287-288, McGraw-Hill, Inc., 1968.

INITIAL DISTRIBUTION LIST

	<u>No. Copies</u>
1. Defense Documentation Center Cameron Station Alexandria, Virginia 22314	2
2. Library, Code 0212 Naval Postgraduate School Monterey, California 93940	2
3. Department Chairman, Code 62 Department of Electrical Engineering Naval Postgraduate School Monterey, California 93940	1
4. Associate Professor G. A. Myers Code 62Mv Department of Electrical Engineering Naval Postgraduate School Monterey, California 93940	10
5. LT Edgar L. Kilborn, Jr., USNR P. O. Box 31 Corea, Maine 04624	1
6. Office of Research Administration Code 012A Naval Postgraduate School Monterey, California 93940	1
7. J. Mensch, Code R220 Defense Communications Engineering Center 1860 Weihly Avenue Reston, Virginia 22090	1
8. R. Lesage, PME 107-5 Naval Electronics Systems Command Headquarters Washington, D. C. 20360	1
9. CDR H. L. Shoemaker, USN, G-80 Naval Security Group Command Headquarters 3801 Nebraska Avenue, N.W. Washington, D. C. 20390	1

Distribution List, Cont'd

	<u>No.Copies</u>
10. LT W. Gadino, USN, Code 103 Naval Ocean Systems Center 271 Catalina Boulevard San Diego, California 92152	1
11. CTTCS A. Ragland, USN, G-52 Naval Security Group Command Headquarters 3801 Nebraska Avenue, N.W. Washington, D. C. 20390	1
12. George B. Johnson Code 7213, Bldg. 33 Naval Ocean Systems Center 271 Catalina Blvd. San Diego, California 92152	1