

AD-A039 560

OFFICE OF THE DIRECTOR OF DEFENSE RESEARCH AND ENGINE--ETC F/G 5/1
THE DOD MEDICAL AND HUMAN RESOURCES LABORATORIES UTILIZATION ST--ETC(U)
SEP 76

UNCLASSIFIED

NL

1 of 2
ADA039 560



1 OF

2

ADA 039 560

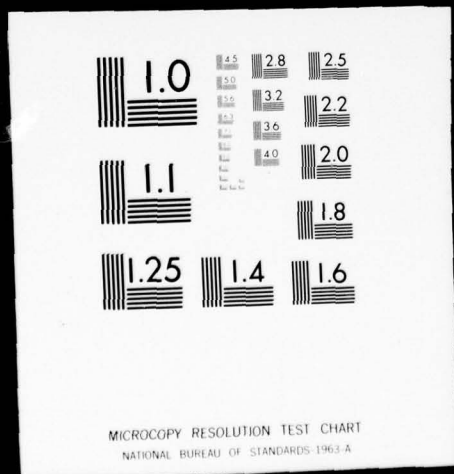

AD A 039560

FINAL REPORT

12
NW

**THE DOD MEDICAL
AND HUMAN
RESOURCES
LABORATORIES
UTILIZATION STUDY**

DDC
RECEIVED
MAY 17 1977
RECEIVED

**Office of the Director of Defense
Research & Engineering**

September 30, 1976

AD No. _____
DDC FILE COPY

DISTRIBUTION STATEMENT A
Approved for public release;
Distribution Unlimited

ACCESSION for	
RTS	White Section <input checked="" type="checkbox"/>
DDC	Diff Section <input type="checkbox"/>
UNANNOUNCED	<input type="checkbox"/>
JUSTIFICATION	
BY	
DESCRIPTION/AVAILABILITY CODES	
AVAIL. and/or SPECIAL	
A	

9 FINAL REPORT.

6 THE DOD MEDICAL AND HUMAN RESOURCES LABORATORIES UTILIZATION STUDY

OFFICE OF THE DIRECTOR OF DEFENSE ✓
RESEARCH AND ENGINEERING

11 30 Sep ~~1976~~ 76

12 186 p.

DDC
RECEIVED
MAY 17 1977
D

Approved for public release; distribution unlimited.

266 200.

mt



OFFICE OF THE DIRECTOR OF DEFENSE RESEARCH AND ENGINEERING
WASHINGTON, D. C. 20301

14 APR 1977

MEMORANDUM FOR DIRECTOR OF DEFENSE RESEARCH AND
ENGINEERING

SUBJECT: Utilization of In-House Medical and Human Resources
Laboratories

By direction of DDR&E memorandum of 27 December 1974, we have completed a detailed study of DoD RDT&E laboratory utilization in the medical and human resources areas. A copy of our report is attached. The report complements a previous report which was forwarded to DDR&E on 17 July 1975 on the DoD physical sciences and engineering in-house laboratories.

The report contains many recommendations which required discussions and actions at various levels within the Military Departments as well as within OSD. Many of the decisions have been made and actions are currently underway implementing the recommendations. We believe that significant enhancement in the effectiveness and productivity of the medical and human resources R&D will result with the implementation of these recommendations.

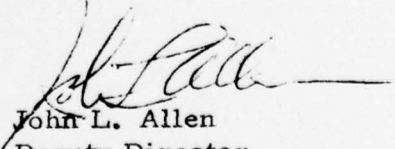
John L. Allen
Deputy Director
(Research and Advanced
Technology)

Attachment

FORWARD

The DoD Medical and Human Resources Laboratory Utilization Study from its initiation through writing the first draft report was the responsibility of Colonel John J. McCambridge. Colonel Stanley C. White was responsible for the final report. Colonel White also served as the technical specialist for the medical laboratories while Colonel Henry L. Taylor served as technical specialist for the human resources laboratories.



John L. Allen
Deputy Director
(Research & Advanced
Technology)

TABLE OF CONTENTS

MEDICAL AND HUMAN RESOURCES
LABORATORIES UTILIZATION STUDY

	<u>Page</u>
GLOSSARY	iv
EXECUTIVE SUMMARY	1
Introduction	1
Approach	1
Results	2
Major Issues	3
1. INTRODUCTION	5
1.1 <u>SECDEF Charge</u>	5
1.2 <u>Study Approach</u>	5
2. FEATURES OF EXISTING LABORATORY SYSTEMS	6
2.1 <u>Army Laboratory System</u>	8
2.1.1 Medical R&D Organizational Structure	8
2.1.2 Army Human Resources R&D Organizational Structure	10
2.2 <u>Navy Laboratory System</u>	12
2.2.1 Medical R&D Laboratories	12
2.2.2 Human Resources R&D Laboratories	15
2.3 <u>Air Force Laboratory System</u>	16
2.3.1 Medical R&D Laboratories	16
2.3.2 Air Force Human Resources Laboratory	18
3. OVERVIEW OF THE SERVICE STUDIES	19
3.1 <u>Overview of Army Study</u>	19
3.3.1 Medical Laboratories	19
3.3.2 Human Resources Laboratories	21

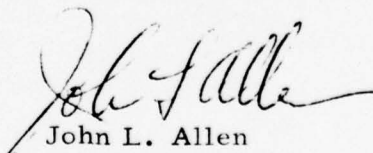
	<u>Page</u>
3.2 <u>Overview of Navy Study</u>	23
3.3 <u>Overview of Air Force Study</u>	25
4. RESULTS OF ODDR&E STUDY	27
4.1 <u>Need for the In-House Medical and Human Resources Laboratories</u>	27
4.2 <u>Management of the Laboratory Complex</u>	27
4.2.1 Multi-Service Concerns	28
4.2.2 Army Laboratory Management	32
4.2.3 Navy Laboratory Management	33
4.2.4 Air Force Laboratory Management	36
4.2.5 Armed Forces Radiobiology Research Institute, Bethesda, MD	37
4.3 <u>Interdependency</u>	39
4.4 <u>Laboratory Size</u>	40
4.5 <u>In-House/Contract Ratio</u>	40
4.6 <u>Medical and Human Resources Technology Base Planning</u>	40
4.6.1 Medical and Human Resources Tech- nology Base Planning Group	42
4.7 <u>Continuing Concerns</u>	44
4.7.1 Dental Research	45
4.7.2 Arctic Medical Research	47
4.7.3 Overseas Laboratories and Units	48
5. SUMMARY OF RECOMMENDATIONS, SERVICE RESPONSES AND FOLLOW-UP ACTION	48
5.1 <u>Inter-Service Recommendations</u>	50
5.2 <u>Army Recommendations</u>	60

		<u>Page</u>
5.3	<u>Navy Recommendations</u>	62
5.4	<u>Air Force Recommendations</u>	67
5.5	<u>Armed Forces Radiobiology Research Institute</u>	68

FIGURES

Figure	Title	
1	Army Organizational Chart, Medical & Human Resources Labs	9
2	Navy Organizational Chart, Medical & Human Resources Labs	13
3	Air Force Organizational Chart, Medical & Human Resources Labs	17

TABLES

Table	Title	
1-1	Army Medical Research and Development Command Laboratories	11
2-1	Navy Medical Laboratories	14
4-1	In-House % of 6.1 and 6.2	41

APPENDICES

See Page 70

GLOSSARY

AFHRL	Air Force Human Resources Laboratory
AFIP	Armed Forces Institute of Pathology
AFLC	Air Force Logistics Command
AFOSR	Air Force Office of Scientific Research
AFRRI	Armed Forces Radiobiology Research Institute
AFSC	Air Force Systems Command
AF/SG	Air Force Surgeon General
AIS	Advanced Instructional System
AMD	Aerospace Medical Division
AMRL	Aerospace Medical Research Laboratory
AMRLA	Arctic Medical Research Laboratory, Alaska
ARI	Army Research Institute for the Behavioral Sciences
ASA(R&D)	Assistant Secretary of the Army (R&D)
ASAF(R&D)	Assistant Secretary of the Air Force (R&D)
ASN(R&D)	Assistant Secretary of the Navy (R&D)
ASUPT	Advanced Simulator for Undergraduate Pilot Training
ATDA	U.S. Army Training Devices Agency
BML	Biomedical Laboratory
BUPERS	Bureau of Personnel, U.S. Navy
CND	Chief of Naval Development
CNET	Chief of Naval Education & Training
DARCOM	U.S. Army Materiel Development and Readiness Command
DCSPER	Deputy Chief of Staff, Personnel
DCSRDA	Deputy Chief of Staff, Research, Development, and Acquisition
DDR&E	Director of Defense Research and Engineering
DHEW	Department of Health, Education, and Welfare
DNA	Defense Nuclear Agency
DoD	Department of Defense
DOT	Department of Transportation
EPA	Environmental Protection Agency
ERDA	Energy Research and Development Administration
HEL	Human Engineering Laboratory
HRRP	Human Resources Research Program

LAIR	Letterman Army Institute of Research
LUS	Laboratory Utilization Study
NADC	Naval Air Development Center
NAMRL	Naval Aerospace Medical Research Laboratory
NAMRU	Naval Medical Research Unit
NASA	National Aeronautics & Space Administration
NAVAIR	Naval Air Systems Command
NAVMAT	Naval Material Command
NAVSUP	Naval Supply Command
NBRL	Naval Biomedical Research Laboratory
NDRI	Naval Dental Research Institute
NELC	Naval Electronics Laboratory Center
NIDR	National Institute of Dental Research
NMRDC	Naval Medical Research & Development Command
NPRDC	Naval Personnel Research & Development Center
NSF	National Science Foundation
NTEC	Naval Training and Equipment Center
ONR	Office of Naval Research
OSD	Office of the Secretary of Defense
PM TRADES	Program Manager, Training Devices
RBE	Relative Biological Effectiveness
R&D	Research and Development
RDT&E	Research, Development, Test and Evaluation
SPEF	Single Program Element Funding
SPO	Systems Project Office
SYSCOMS	Systems Commands, U. S. Navy
TCP	Technical Coordinating Paper
TRADOC	Training and Doctrine Command
TSG	The Surgeon General, Army
USAARL	U. S. Army Aeromedical Research Laboratory
USAFSAM	United States Air Force School of Aerospace Medicine
USAIDR	U. S. Army Institute of Dental Research
USAISR	U. S. Army Institute of Surgical Research
USAMBRDL	U. S. Army Medical Bioengineering Research Development Laboratory
USAMRDC	U. S. Army Medical Research & Development Command
USAMRIID	U. S. Army Medical Research Institute for Infectious Diseases

USARIEM

U. S. Army Research Institute of Environmental
Medicine

USUHS

Uniformed Services University of the Health
Sciences

WRAIR

Walter Reed Army Institute of Research

EXECUTIVE SUMMARY

INTRODUCTION

The Laboratory Utilization Study (LUS) of the DoD medical and human resources in-house laboratories was initiated in December 1974, by memorandum from DDR&E to the Assistant Secretaries for Research and Development of the Military Departments. A LUS Coordinating Board was established. The Board was chaired by the Acting Assistant Director for Environmental and Life Sciences, ODDR&E, and consisted of members from ODDR&E and the Military Departments. The study charter was issued on 15 January 1975. The Medical and Human Resources LUS complemented a previous review of the DoD physical sciences and engineering in-house laboratories (reference 1)¹ chaired by the Deputy Director for Research and Advanced Technology. The two studies, taken together, have assessed the utilization of all DoD in-house laboratories.

The objectives of the Medical and Human Resources LUS were to (1) determine the requirements for the in-house laboratories; (2) assess the capability of the laboratories to meet these requirements; (3) identify excess capacity, overlapping capabilities, shortfalls or instances where R&D should be contracted to industry; and (4) define a program to upgrade the quality of the laboratories.

APPROACH

The approach adopted for the study was as follows:

Each Service conducted a study of its own laboratories and recommended follow-on actions. Guidelines to the Services were that maximum use should be made of previous studies and other on-going studies. In addition to the studies conducted by the Services, the Armed Forces Radiobiology Research Institute (AFRRI) of the Defense Nuclear Agency provided the Coordinating Board sufficient data about its facility and programs to enable the Board to include AFRRI in the study. The reports from the Service studies and

1/ See bibliography for references.

data from AFRRRI served as input to the DoD Medical and Human Resources LUS. The Coordinating Board performed an independent review of the DoD laboratories in addition to a critique of the Service reports.

The DoD LUS focused on the following principal areas: Need for the in-house medical and human resources laboratories; Management of the laboratory complex; Interdependency; Laboratory size; Medical and Human Resources technology base planning; and Continuing concerns.

RESULTS

The DoD Medical and Human Resources Laboratory Utilization Study concluded that these laboratories provide unique technical input to military planning and decision making and that their manning levels and in-house/contract ratio are appropriate.

The management improvement recommendations contained in Section 4.2 of The DoD Laboratory Utilization Study (reference 1) were found to be applicable to the Medical and Human Resources Laboratories. These recommendations relate to improved personnel management practices with increased authority and flexibility for laboratory directors in managing their personnel force, implementation of financial controls alone on manpower and closer integration of the laboratories into the decision making process of the Military Departments. In addition to these general recommendations, the Medical and Human Resources LUS identified the need to better incorporate these laboratories into the weapon system acquisition process.

A number of inter-Service issues, as well as individual Service issues, were raised as a result of the study. The Services' responses to the study report draft and their positions on the various issues were discussed and a DDR&E "recommendation and action required" was forwarded to the Assistant Secretaries of the Military Departments (Research and Development) on 27 September 1976.

MAJOR ISSUES

Two issues concerned with joint planning and increased Service interdependency of human resources and medicine and life sciences R&D are closely related. The DDR&E recommendation concerning these two issues was that joint planning should be done for defined, bounded, technical areas and that areas of interdependency should be selected on a case-by-case basis. Formation of a tri-Service ad hoc group to identify areas for joint planning and increased interdependency was recommended. The results of their work are to be reported to ODDR&E by 2 May 1977.

A recommendation was made that the Army be established as the lead Service for all medical and human resources Technology Base R&D associated with the human aspects of helicopter operations. The Army was designated as the lead in developing and coordinating a plan to effect this recommendation by 2 May 1977. A recommendation was made that the Navy re-examine its special laboratory facilities with a view of consolidating its Aviation Medicine research program. After discussions of these recommendations with the Navy and subsequently with the other Services, it was concluded that the recommendation should be broadened to include the Air Force and Army, but limited in technical scope to the study of facilities for performing acceleration, vibration, and impact research. The Air Force was designated the lead in performing and coordinating, by 1 June 1977, a tri-Service study on the requirement for all facilities in acceleration, vibration, and impact. In view of a continuing concern by Congress and the DoD about the need for DoD to conduct research in dental caries and periodontal disease, a recommendation was made that the DoD dental research program be reviewed in depth. The objectives of the review are to establish the need for, the level of effort required, and the adequacy of coordination with the civil sector of DoD research in the area. The Navy was requested to lead in reassessing the DoD dental R&D program.

Another recommendation suggested reimbursement from appropriate funding for non-Tech Base work. All Services agreed in principle with the recommendation and funding changes are to be completed with the fiscal 1979 POM submit.

Issues were raised with the Army concerning management of the Biomedical Laboratory at Edgewood Arsenal and of the Army human resources program. It was agreed to keep these two issues open for a year to observe the effectiveness of the R&D program and management.

The Navy agreed to several management changes in its laboratory structure. The principle changes are (1) to **close** the medical field laboratory at Camp Lejeune and transfer work to other laboratories; (2) to consolidate the Navy Toxicology Unit at the Naval Medical Research Institute with a similar unit at the USAF 6570th Aerospace Medical Research Laboratory at Wright-Patterson AFB, Ohio; and (3) to establish a Steering and Advisory Committee for all Navy 6.2 and 6.3A human resources R&D. Another issue, the future posture of the Navy's DoD Biosciences Research Laboratory, Berkeley, California has not been resolved. Resolution is expected during 1977.

The Air Force is currently revising the regulation which deals with the management of personnel and training requirements and utilization of the R&D products.

A major recommendation is related to the **disposition** of the Armed Forces Radiobiology Research Institute (AFRRI). Of several alternatives considered, it was recommended that AFRRI be transferred from the Defense Nuclear Agency (DNA) to the Uniformed Services University of the Health Sciences as a combined research and training facility. Based upon mission requirements, the DNA did not concur with the LUS recommendation. Additional documentation supporting the DNA position indicated that AFRRI will be required to support DNA's long range requirements for Nuclear Weapons Effects, particularly with regard to tactical nuclear weapons. DNA recommended that AFRRI remain an integral subordinate unit of DNA in order to support DNA requirements. Based upon this recent detailed analysis, the DDR&E concurred with the DNA recommendation.

1. INTRODUCTION

This study of the utilization of the DoD medical and human resources in-house laboratories was initiated in December 1974 by memorandum to the Assistant Secretaries of the Military Departments (R&D) from Dr. Malcolm R. Currie, DDR&E, in response to a Management Objective of the Secretary of Defense (reproduced in Appendix A). Subsequently, a Coordinating Board chaired by the Acting Assistant Director for Environmental and Life Sciences, ODDR&E, and consisting of members from the Military Departments was formed (membership shown in Appendix B) and the study was begun by issuance of the study charter on 15 January 1975 (Appendix C).

This study complemented a previous review of the DoD physical sciences and engineering in-house laboratories (reference 1) chaired by the Deputy Director for Research and Advanced Technology. The two studies, taken together, assessed the utilization of all DoD in-house laboratories.

1.1 SECDEF Charge

The charge for the study was to (1) determine the requirements for the in-house laboratories; (2) assess the capability of the laboratories to meet these requirements; (3) identify excess capacity, overlapping capabilities, shortfalls or instances where R&D should be contracted to industry; and (4) define a program to upgrade the quality of the laboratories. The study was to be completed and a plan of action to correct any deficiencies identified submitted to the R&D Policy Council in September 1975 and to SecDef in December 1975.

1.2 Study Approach

The approach adopted for the study was as follows:

(1) First, each Service would conduct a study of its own laboratories using the same criteria and recommending follow-on actions.

(2) Maximum use would be made of previous and other on-going studies.

(3) The Service studies would be coordinated by the OSD/Tri-Service Coordinating Board.

(4) The Service studies would serve as an input to a follow-up ODDR&E study to assimilate and critique the Service studies and to carry out any additional investigations needed.

The Army, Navy and Air Force conducted individual studies of their assigned laboratories. The Armed Forces Radiobiology Research Institute (AFRRI) of the Defense Nuclear Agency was asked to provide to the Coordinating Board sufficient data about its facility and programs to enable the Board to include AFRRI in the consideration of all DoD assets in the medical and human resources areas.

The study focused on five principal issues:

(1) Could the DoD function satisfactorily in these areas without the in-house laboratories?;

(2) If the answer to (1) is 'no,' how could we best organize and operate the laboratory structure to get the most out of the laboratories?;

(3) What is the most appropriate division of effort between the medical and human resources laboratories, especially in the areas of interface such as human engineering?;

(4) What is the best division of effort among the in-house laboratories, industry, the universities and other performers of the program?; and

(5) What is the proper size of the laboratory complex in view of the foregoing considerations?

2. FEATURES OF EXISTING LABORATORY SYSTEMS

The Department of Defense medical and human resources laboratories are the principal sources of expertise within the Department of Defense for addressing the unknowns associated with the "people" portion of the military forces. A statistic that has often been cited portrays the "people" costs of our defense posture as accounting for 56% of the total defense budget. While this figure is

somewhat distorted since the retirement costs for former servicemen are included, the cost attributable to the human operators of weapon systems and the manpower associated with our ground forces amounts to at least \$42B in FY 76, 49% of the total "discretionary" defense budget. While there are significant amounts of R&D performed in the private sector in the hardware areas of electronics, materials, etc., there are, outside of routine health and medical care R&D, very few sources of expertise applicable to (1) the selection, training and use of the human operator or maintainer as a component of defense weapon systems or for other military jobs, (2) the maintenance of health of military populations in adverse epidemiological environments, and (3) the emergency care, evacuation and restorative care of combat casualties. These in-house laboratories, therefore, represent the major resource for the accomplishment of the following functions:

- o Advancing the Technology Base in defense related problems.
- o Providing day-to-day expert advice and assistance to military decision-makers and planners on the human element of defense operations.
- o Advising weapon system designers on optimum man-machine design characteristics based on human performance parameters, human environmental stress constraints, and selection and training of most suitable operator populations.
- o Providing expert advice and assistance in the selection, classification and training of military personnel.
- o Providing technical advice for the planning of the triage, care, evacuation and subsequent treatment and return to duty of casualties in wartime situations, and performing research to improve this complex process.

The 27 medical and human resources laboratories manage about 2% of the DoD RDT&E program funds and account for about 10% of the total manpower in DoD RDT&E laboratories. They directly manage about 8½% of the Technology Base program with about 65% of this amount being performed in-house and about 35% being performed on contract.

In attempting to assess whether there are more appropriate organizational and functional alignments for the in-house medical and human resources laboratories, it is necessary first to have a satisfactory understanding of the current organizational and functional relationships. To accomplish this, the Military Departments were asked to describe the principal features of the existing laboratory systems within their Departments. In addition, the Coordinating Board performed several independent analyses of specific functional areas across the three Services. Most of the laboratories concerned were visited either by the Service study group or by the ODDR&E participants. In addition, of course, most of those involved in the study had many years of first hand familiarity with the in-house laboratories.

This study was performed as a complement to the Laboratory Utilization Study of the physical sciences and engineering laboratories previously conducted (May 1974-March 1975) under the chairmanship of the Deputy Director (Research and Advanced Technology), ODDR&E. The earlier study addressed all of the in-house laboratories except those in the medical and human resources areas. This division of effort was decided upon in order to limit the technical range required of each of the study teams. The laboratories addressed in the earlier study, as well as those addressed in this study, are shown in Appendix D. The two studies taken as a whole address all of the Defense in-house laboratories.

2.1 Army Laboratory System

The Army medical and human resources R&D programs are supported by a system of twelve laboratories. Each program, ((1) Medical, (2) Human Resources) with its supporting laboratories, is managed separately. An organizational chart showing funding and program management paths is given in Figure 1.

Coordination of the two programs is attempted by reciprocal attendance of program managers at program reviews and planning sessions. There is no formal coordinating mechanism.

2.1.1 Medical R&D Organizational Structure

The Commander and staff of the U. S. Army Medical R&D Command (USAMRDC) plan, coordinate, execute, supervise, and review the Army medical R&D program, and perform RDT&E staff functions for the Army Surgeon General.

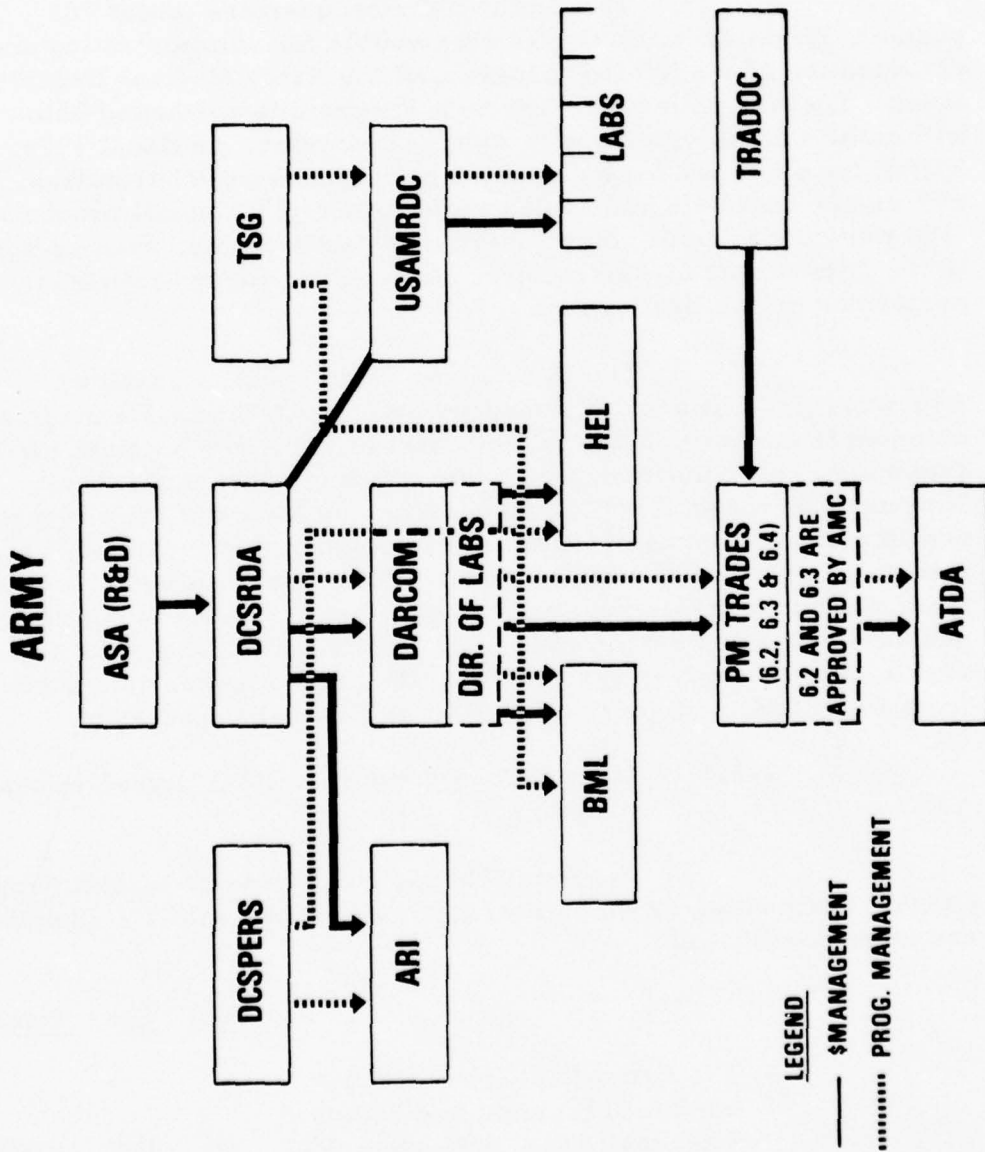

FIGURE 1

The Commander, USAMRDC, commands the designated Army Medical Research and Development Command laboratories and directs and manages their research and development efforts. These laboratories and their FY 75 authorized end strengths are shown in Table 1-1.

The USAMRDC Headquarters (about 160 people), Washington, D. C., is responsible for administration and coordination of the RDT&E program of the Army Medical Department. The Army Medical Research Program is conducted both within the United States and in foreign countries. In fiscal 1975, 69% of the program was performed in the in-house laboratories, 30% on contract with universities and industry. A small proportion (1%) was conducted in other government laboratories, such as those in the Department of Agriculture. All contracting by AMRDC is performed by the Headquarters.

The U. S. Army Biomedical Laboratory, Edgewood Arsenal area of Aberdeen Proving Ground, is a medically oriented laboratory, but it is not a part of the Army Medical R&D Command. A memorandum of understanding between the Army Surgeon General and the Commander, Army Materiel Development and Readiness Command (DARCOM), provides that technical, i. e., medical, supervision of this laboratory's research program comes from The Surgeon General and that all other functions of command and administration are a responsibility of the DARCOM. As a result, this laboratory has two separate lines of supervision, one from DARCOM, and one from the Army Medical Department.

2.1.2 Army Human Resources R&D Organizational Structure

The Army Human Resources Research Program (HRRP) is executed by the following organizations with FY 75 authorized end strengths shown:

	<u>Mil</u>	<u>Civ</u>	<u>Total</u>
o The Army Research Institute for the Behavioral and Social Sciences (ARI), Arlington, VA	36	232	268
o U. S. Army Human Engineering Laboratory (HEL), Aberdeen Proving Ground, MD	<u>31</u>	<u>119</u>	<u>150</u>
Total	67	351	418

TABLE 1-1

ARMY MEDICAL RESEARCH AND DEVELOPMENT COMMAND
LABORATORIES

FY 75 Authorized End Strengths

	<u>Mil</u>	<u>Civ</u>	<u>Total</u>
Walter Reed Army Institute of Research (WRAIR), Washington, D. C. (includes overseas detachments in Thailand, Brazil, Malaysia, Kenya and Panama)	456	537	993
U. S. Army Institute of Dental Research (USAIDR), Washington, D. C.	62	26	88
U. S. Army Medical Bioengineering Research and Development Laboratory (USAMBRDL), Fort Detrick, Maryland	30	76	106
U. S. Army Medical Research Institute of Infectious Diseases (USAMRIID), Fort Detrick, Maryland	317	198	515
U. S. Army Institute of Surgical Research (USAISR), Fort Sam Houston, Texas	136	77	213
U. S. Army Research Institute of Environmental Medicine (USARIEM), Natick, Massachusetts	83	77	160
U. S. Army Aeromedical Research Laboratory (USAARL), Fort Rucker, Alabama	54	45	99
Letterman Army Institute of Research (LAIR), Presidio of San Francisco, California	<u>264</u>	<u>225</u>	<u>489</u>
Totals	1402	1261	2663

In fiscal 1975, 57% of the Army HRRP was conducted in the in-house laboratories and 43% on contract. Staff cognizance for the HRRP is a responsibility of the Deputy Chief of Staff for Personnel (DCSPER) having been transferred there from the Office of the Chief of Research, Development & Acquisition in 1974. ARI formulates and proposes its programs in the area of training performance and organizational R&D for approval by DCSPER, while the DARCOM staff is responsible for approval of the programs of HEL and PM TRADES. Staff cognizance for PM TRADES program is the responsibility of the DCSRDA.

2.2 Navy Laboratory System

The Navy laboratory system in the medical and human resources area may be divided into the following categories: (1) Medical laboratories under the Naval Medical R&D Command (NMRDC); (2) Naval Personnel R&D Center under BUPERS; (3) Naval Training Equipment Center under the Chief of Naval Education and Training (CNET); (4) the NAVMAT laboratories under the Director of Navy Laboratories, many of whom have cells of medical or human resources R&D activity, and (5) the Naval Biomedical Research Laboratory under Office of Naval Research (ONR). There is a sixth segment of R&D activity - the contract work sponsored directly by ONR. Figure 2 shows lines of funding management and program influence; but not command lines.

2.2.1 Medical R&D Laboratories

In FY 75, approximately \$30 million of medical and life sciences R&D was funded by the Navy of which \$24 million, or 80%, flowed through NMRDC. ONR is the second most important agency in this area as it funds about 16% of the work. Since some of the NMRDC funds are transferred to ONR for contract work, ONR actually contracts for about a third of the \$30 million total. Small amounts of R&D funding are managed through NAVAIR and NAVSUP. A summary of fund sources by program element is shown in Appendix E.

Medical and biomedical R&D activities are conducted in twelve laboratories, ten under the Naval Medical R&D Command, one laboratory under ONR, and a department of the Naval Air Development Center (NADC) under the Naval Materiel Command. The individual laboratories and their FY 75 authorized end strengths are shown in Table 2-1.

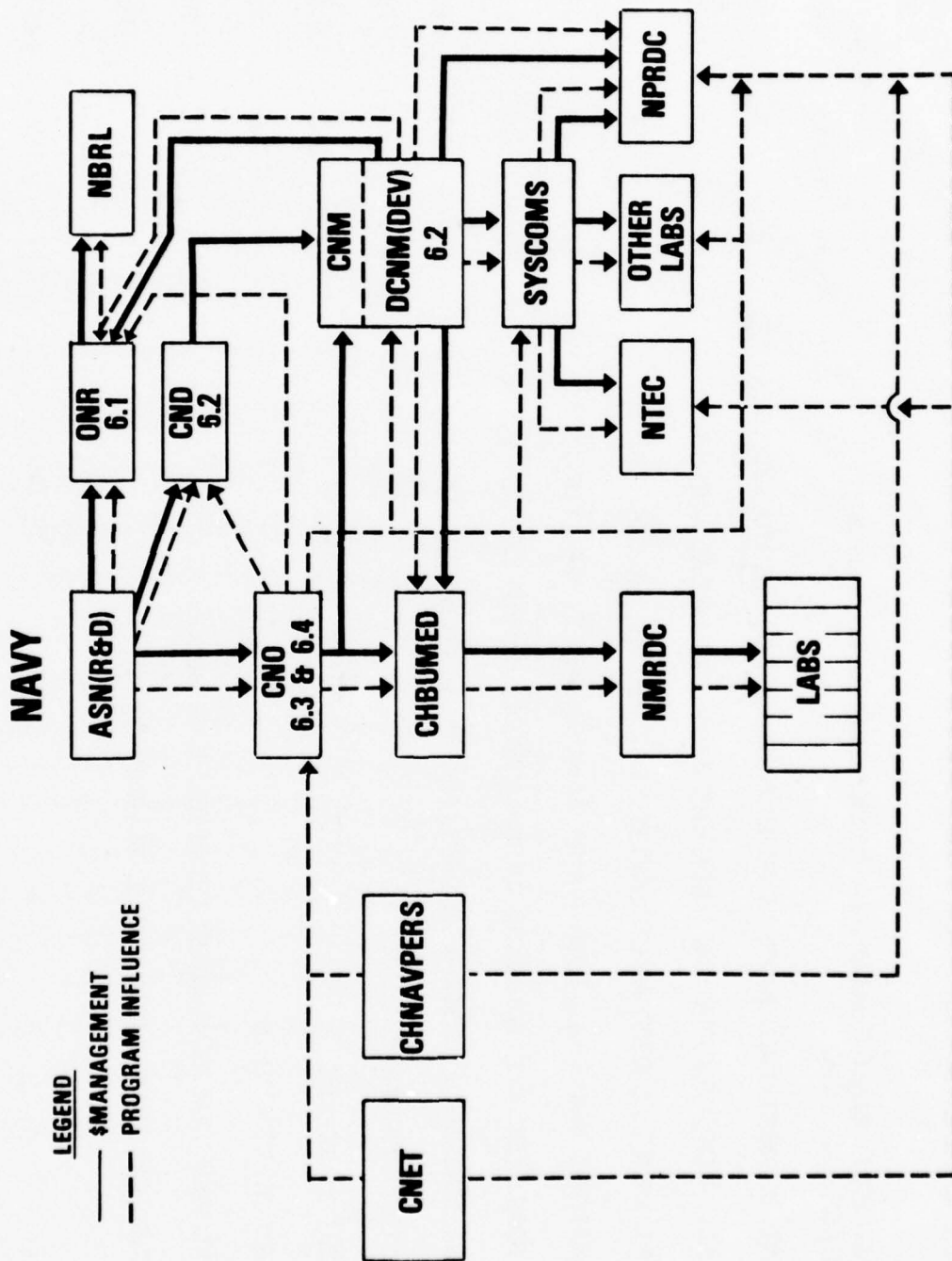

FIGURE 2

NAVAL MEDICAL LABORATORIES

	<u>Mil</u>	<u>Civ</u>	<u>Total</u>
NAVAL AEROSPACE MEDICAL RESEARCH LABORATORY, PENSACOLA, FLA.	54	115	169
NAVAL BIOMEDICAL RESEARCH LABORATORY, BERKELEY, CALIF.	14	6	20
NAVAL BLOOD RESEARCH LABORATORY, CHELSEA, MASS.	17	13	30
NAVAL DENTAL RESEARCH INSTITUTE, GREAT LAKES, ILL.	23	16	39
SUBMARINE MEDICAL RESEARCH LABORATORY, GROTON, CT.	35	60	95
MEDICAL FIELD RESEARCH LABORATORY, CAMP LEJEUNE, N.C.	30	40	70
NAVAL MEDICAL RESEARCH INSTITUTE, BETHESDA, MD.	209	207	416
NAMRU-2, TAIWAN	32	4	36
NAMRU-3, EGYPT	24	216	240
NAMRU-5, ETHIOPIA	19	58	77
NAVAL HEALTH RESEARCH CENTER, SAN DIEGO, CALIF.	28	72	100
NADC(CREW SYSTEMS DEPT.), WARMINSTER, PA.	32	154	186
	<hr/>	<hr/>	<hr/>
TOTAL	517	961	1478

NMRDC is the major coordinator of medical and life sciences R&D in the Navy. It has management and coordination responsibility for all of the Navy medical R&D facilities except the Naval Biomedical Research Laboratory of ONR and the Crew Systems Department of NADC. The laboratories' areas of principal activity are reasonably exclusive except for the Aviation Medicine area wherein NAMRL, Pensacola; Detachment 1 of NAMRL, Michaud, Louisiana; and the Crew Systems Department of NADC, Warminster, are all active. The overseas NAMRUs in Taiwan, Egypt, and Ethiopia are pursuing work in infectious diseases endemic to those geographical areas.

The Medical Field Research Laboratory at Camp Lejeune, North Carolina, is a small organization whose principal function is development and testing in support of the field Marine. In recent years the test support function has been its predominant R&D activity.

2.2.2 Human Resources R&D Laboratories

In FY 75, over \$31 million of human resources R&D was funded by the Navy, of which 62% was managed through the Naval Materiel Command, 22% by the Bureau of Personnel, and the remaining 16% by the Office of Naval Research. A summary of fund sources by program element is shown in Appendix E. Because of the generally complex procedure for managing RDT&E funds in the Navy, the Research work is directed by the Chief of Naval Research, the Exploratory Development by the Chief of Naval Development and the Advanced and Engineering Development under the Director of Research, Test and Evaluation (Office of the Chief of Naval Operations).

Human resources R&D work is conducted at the Navy Personnel R&D Center under Bureau of Naval Personnel; the Naval Training Equipment Center under CNET; and several sub-divisions of the laboratories and centers under NAVMAT. There is some work funded under human resources program elements conducted at NAMRL at Pensacola. In addition, there is other related work at Pensacola and San Diego not funded by human resources. FY 75 authorized end strength for NPRDC is shown below:

	<u>Mil</u>	<u>Civ</u>	<u>Total</u>
Navy Personnel Research and Development Center, San Diego, California .	28	276	304

2.3 Air Force Laboratory System

The two medical laboratories are organized under the supervision of the Aerospace Medical Division (AMD) of the Air Force Systems Command. In addition to the R&D mission of these laboratories, AMD also has missions in specialized medical care and education of medical and life sciences professional personnel. AMD Headquarters provides a single point of management for the medical and life sciences R&D program. The Air Force Human Resources Laboratory reports directly to the Director of Science and Technology, Headquarters, AFSC. These relationships are shown in Figure 3. The Research (6.1) contract program is administered by the Air Force Office of Scientific Research (AFOSR).

2.3.1 Medical R&D Laboratories

The Air Force laboratory system for the conduct of medical and human resources R&D is the most simply organized of the three Services. The two medical laboratories with FY 75 authorized end strengths are shown below:

	<u>Mil</u>	<u>Civ</u>	<u>Total</u>
Aerospace Medical Research Laboratory, Wright-Patterson Air Force Base, Ohio	133	160	293
USAF School of Aerospace Medicine, Brooks Air Force Base, Texas	<u>392</u>	<u>289</u>	<u>681</u>
Total	525	449	974

The Air Force funds about \$25 million of medical and life sciences R&D annually. All of these funds flow through the Aerospace Medical Division except some 5% which are contracted by AFOSR. The emphasis is on human performance in adverse environments, leaving the more clinical research to the Army and Navy.

Much of the overall R&D management for both USAFSAM and AMRL is provided by the Directorate of Research and Development in Headquarters, Aerospace Medical Division. Planning and programming functions centralized in this staff function are not replicated in the subsidiary organizations. This staff function provides interface with Headquarters AFSC, Product Divisions and

AIR FORCE

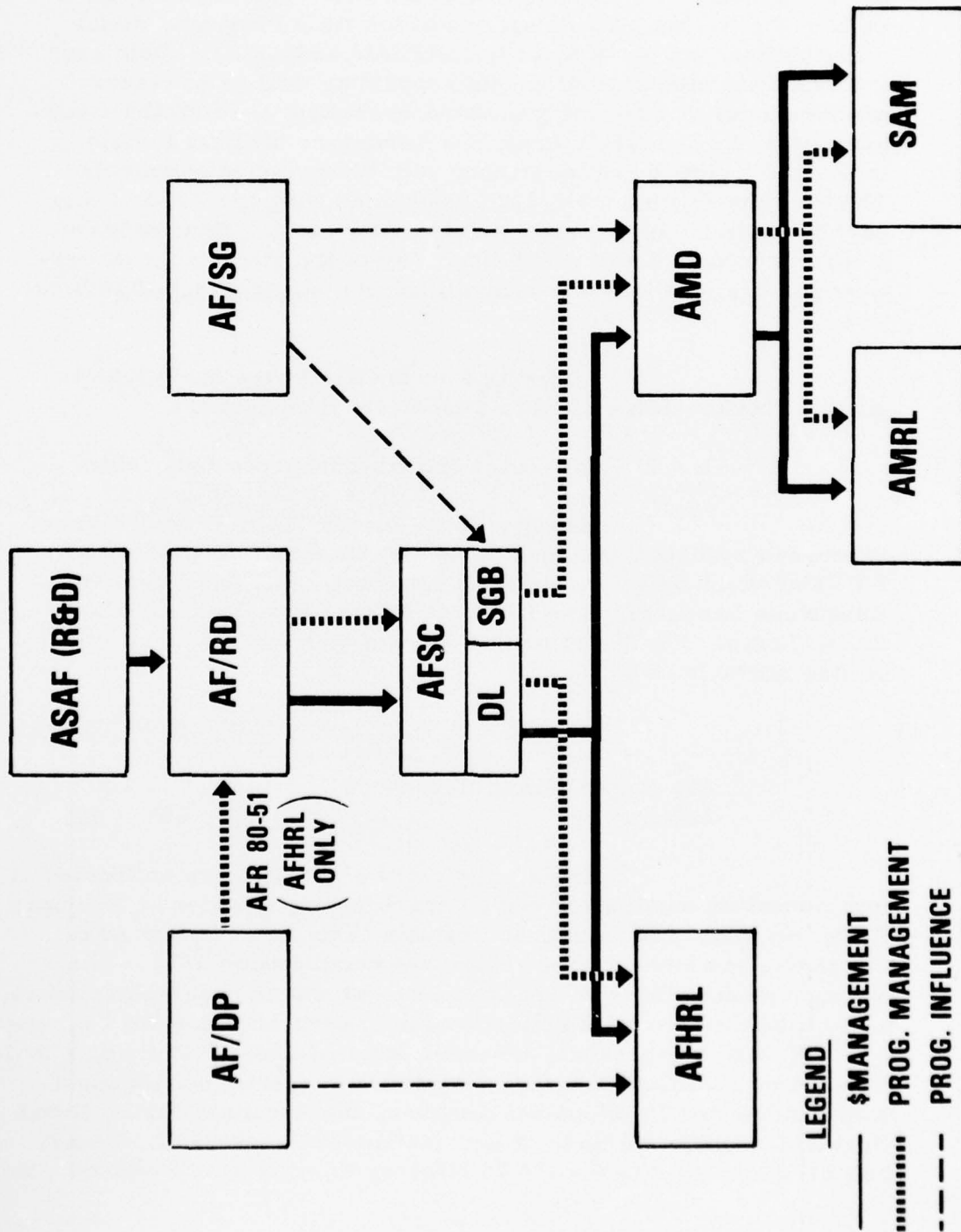

Operating Commands to define requirements for research and development and integrates planning to take advantage of mutually complementary R&D capabilities of the two organizations. In each of the five major subsections of the R&D Program, major contributions are made by both USAFSAM and AMRL. Both are involved in systems development support as well as in research and development supporting medical operations. From the standpoint of its R&D mission area, the Aerospace Medical Division looks like a very large laboratory with two major subelements. The R&D management overhead associated with operation of this part of the AMD mission is approximately 9.5%. This compares favorably to the cost of overhead in any of the other large laboratories whose functions are centralized in a single geographic location.

Appendix A of the Air Force Study Report gives a detailed description of facilities and equipment.

2.3.2 Air Force Human Resources Laboratory

The Air Force funded \$14 million of human resources research and development at its single laboratory in FY 75 of which 54% was placed on contract. The Air Force Human Resources Laboratory has its headquarters at Brooks Air Force Base, Texas. FY 75 authorized end strength for the Laboratory is also shown below:

	<u>Mil</u>	<u>Civ</u>	<u>Total</u>
Air Force Human Resources Laboratory	128	238	366

The six divisions of AFHRL are collocated at four operating locations. The Flying Training Division at Williams AFB, Arizona, and Technical Training Division at Lowry AFB, Colorado, are housed in new facilities completed in 1972. The Flying Training Division operates several unique part task trainers, as well as the Advanced Simulator for Undergraduate Pilot Training (ASUPT) which represents advanced state-of-the-art in flying simulation. The Technical Training Division is presently conducting a major Advanced Development program, the Advanced Instructional System (AIS), in training. A new facility at Brooks AFB, Texas, has been approved in the FY 75 Military Construction Program which

will house the divisions presently located at Lackland AFB with the laboratory staff on Brooks AFB. The personnel related division, located at Lackland AFB, operate an 1108 UNIVAC computer and use extensive longitudinal data files in the performance of personnel R&D. The Advanced System Division located at Wright-Patterson AFB, Ohio has laboratories for conducting exploratory development in simulation.

The Chapman Report (Air Force's contribution to the Laboratory Utilization Study) advocated centralized management of all Research funds (6.1) with emphasis on expending these funds in the civil sector. The Air Force Office of Scientific Research (AFOSR) has been delegated overall responsibility for the management of Air Force Research funds. As a result, the Research monies currently expended by AMD and AFHRL will, beginning in FY 76, be centrally managed by AFOSR. Because of a close coupling between the Exploratory Development (6.2) programs of AMD and HRL, and the research plans of AFOSR in the areas of medical, biological and behavioral sciences, this centralization of 6.1 resources should result in a synergistic enhancement of the total utilization of these 6.1 funds to support the missions of these laboratories.

3. OVERVIEW OF THE SERVICE STUDIES

3.1 Overview of Army Study

The Army study group was composed principally of in-house Army military and civilian personnel augmented by civilian consultants. It was conducted by two separate subpanels addressing the medical and human resources areas respectively. No final integration of these subpanel studies was performed. Liaison officers were assigned between subpanels and draft reports were exchanged as the study evolved. The Army submitted two reports in March 1975 (references 2 and 3). The membership of the Army study group is listed in Appendix F.

3.1.1 Medical Laboratories

The mission statements for all the laboratories were felt to be written in sufficient detail to ensure that no unnecessary duplication in R&D is "mission inherent." It was pointed out that the number of laboratories has been reduced in the past two years from 12 to 8 by elimination or consolidation of laboratories and staffs at several locations. Details may be found in Appendix G.

Collocation of the laboratories with their users was considered a strength of the Army laboratories. In each instance, they are located either in a recognized research center where the intellectual stimulation and competition of peer groups is significant or they are collocated with equipment developers to increase the coupling of their work.

Manpower in the Army medical R&D laboratories has decreased about 19% since end FY 73 and 6% since end FY 74 due to the consolidations noted above and other manpower reduction actions.

AMRDC has not yet formally established a lead laboratory system although it has informally operated under a concept of laboratory specialization to eliminate duplicative research efforts. A summary of the areas of Army medical research specialization by laboratory may be found in Appendix H. The Committee felt that in spite of the establishment of lead laboratories, care should be taken to require human use and legal review, and contracting authority for projects and contracts at Headquarters, AMRDC, because of the sensitive problem of utilization of human subjects and patients in medical research.

With regard to interdependency, the Army Committee felt that de facto interdependency already exists in many areas. In addition, the Army feels it may develop increased dependence on the Navy for research in schistosomiasis and mycoplasma diseases with a concurrent decrease in its own effort in these areas. The progress being made by the ad hoc Tri-Service Aeromedical Research Coordination Working Group was also cited. Lead agency assignments for specific medical research areas were strongly supported.

The Committee recommended that no additional Tri-Service institutes or activities comparable to the AFIP or AFRI be formed. It was felt that their isolation from Service direction and consequent loss of responsiveness to Service specific requirements, coupled with their minimum flexibility as established, are not offset by any savings in resources or other advantages.

Management and coordination of the Army medical program by Headquarters, AMRDC, was felt to be effective and was recommended for continuation.

With regard to possible reductions in manpower, the Committee pointed out that in the past two years, i. e., from 30 June 1973 to 15 March 1975, Army medical R&D strength has dropped by 19% from 3,673 to 2,989. When taken against the end FY 74 strength, the reduction is about 6%. Specific additional reductions, should additional cuts be required, were identified.

The Committee felt that the quality of the labs was high - high enough to attract and retain quality personnel at all levels of employment with two exceptions: military physicians and military life scientists. In both instances, it was felt that the military system does not provide incentives for them to remain in the laboratories.

The in-house to contract ratio within the medical laboratories was found to be essentially constant over the past decade, from 41% of the work on contract in FY 65 to 36% of the work on contract in FY 74. A maximum of 46% was reached in FY 69 and 70, the only two years since FY 65 that the ratio has exceeded 41%. This in-house to contract ratio was felt by the Committee to be appropriate and no changes were recommended.

3.1.2 Human Resources Laboratories

The Human Resources Subpanel found that the missions of the human resources laboratories were appropriately stated to avoid duplicatory R&D and to address Army needs adequately. The size and number of the laboratories were assessed to be appropriate to accomplishment of the assigned mission. They stated, however, that the R&D responsibilities of all Army laboratories engaging in human factors type work should be reviewed for possible overlap of responsibilities. The Committee generally supported the lead laboratory concept and pointed out that establishment of appropriate lead laboratories would require leadership on the part of DCSRDA since laboratories outside of the human resources research program (which is under DCSPER) must be included.

The Committee pointed out that there is no general agreement among the various participants in human resources R&D on the meaning of such common terms as human engineering or human factors. A prerequisite to effective designation of lead laboratories is the agreement on Technology Coordinating Papers (TCP) sub-areas and their definition similar to that which has already been accomplished in the medical R&D area. The Joint

Medical Research Conference has been an important contributor to this agreement and the Army study group felt that a similar group should be considered for establishment in the human resources area.

Strong support was given for establishment of appropriate recognition programs for individuals, laboratories, and other activities to foster the development of excellence in competitive areas.

The Committee recommended consideration of the merging of ARI and HEL as it appears that savings in administrative personnel may be possible. The details of this merger with regard to location, organizational placement, and schedule should be studied in more detail.

With regard to the in-house to contract ratio, the Committee felt that the current ratio was appropriate (ARI 46% in-house and HEL 80% in-house). The wide variation in percentage of in-house work is ascribed to HEL's close support relationship to DARCOM's development programs.

Concern was expressed about the adequacy of participation of the laboratories in the materiel acquisition process. The involvement of HEL in major systems has grown considerably in recent years. However, ARI does not yet enjoy the close relationship with Program Managers that the DARCOM laboratories do. ARI is closely involved with laboratory support in the area of manpower management. The Committee recommended that all of the human resources laboratories should be brought into the decision making process before decisions are finalized. The need for ARI to develop a closer association with Program Managers was emphasized.

There was felt to be a lack of adequate Technology Base funding in training devices R&D. The Committee recommended that ATDA be funded for this work or that the mission should be assumed by PM TRADES.

The danger of excessive job shop work in the laboratories in response to personnel managers was cited. The principal danger lies in the diversion of Technology Base resources to the solution of short term problems. The importance of performing such work is recognized but the need for other than Technology Base funding to support the work is pointed out. The Committee also

pointed out that the assignment of Army staff supervision of the human resources program to the DCSPER invites a conflict of interest with regard to other user needs. It was recommended that consideration be given to reassigning this function to the DCSRDA.

The 6.1 and 6.2 programs at ARI were recommended for SPEF (Single Program Element Funding). This arrangement would give the Director of ARI a more positive role in planning his program and allocating resources.

The difficulty in attracting qualified senior laboratory personnel because of the Civil Service salary ceiling was pointed out. As a result, attraction of quality leadership must at present be based upon other job factors, such as delegation of authority, participation in major problems and consultation by decision makers. The helpful effect of periodic visits by senior DoD and Department of Army personnel to the laboratories was cited as a means for motivating senior laboratory management.

3.2 Overview of Navy Study

The Navy study was performed by a group composed principally of non-Navy civilian consultants chaired by Mr. Bruno Augenstein, Resident Consultant to the RAND Corporation. The Navy report was submitted in May 1975 (reference 4). The study group membership is given in Appendix F.

The Committee determined that the Navy medical and human resources laboratories were effective, based on their overall contribution to the long term enhancement of Naval capability; but they felt that there was opportunity for improvement in their effectiveness. Considerable emphasis was placed in the Navy report on the multiplicity of Navy missions on land, on and under the sea, and in the air as a justification for the Navy engaging in R&D and maintaining expertise in all four environments. While this was asserted, no further supportive rationale was given which acknowledged the existence of other DoD and non-DoD programs.

The management structure of medical and human resources R&D in the Navy was found to be in a transitory stage involving the recent establishment of the Naval Medical R&D Command and the

relatively recent designation of the Naval Personnel R&D Center as the coordinating agency for all Naval R&D in the area of personnel and training. The Committee felt that the transition begun by these organizational actions should continue.

The Navy report pointed out that the perception of the laboratories' effectiveness on the part of the operational forces was mixed. It was felt that one of the causes of the mixed reaction is that many operational components lack a sufficient understanding of the kinds of services the laboratories are capable of providing in response to Navy needs.

The Civil Service rules governing R&D professionals were found to be overly restrictive and impeded the exercise of effective management on the part of laboratory directors. The Committee recommended that these rules should be made more flexible, allowing for longer probationary periods and personnel contract renewal options. While the Committee recognized that revision of Civil Service rules is generally difficult, it noted that precedents for their recommended changes already exist.

The Committee expressed concern over possible adverse effects of overcentralization of R&D work in relation to the DoD emphasis on interdependence. In fact, the Navy report treated the interdependence issue by stating that the results of several other on-going studies were required prior to making any recommendations for interdependency. In addition, the Committee felt that the budget and program review processes, while satisfactory, are "at times excessive." They recommended a re-evaluation of these processes.

The Committee found substantial awareness in the laboratories of the related work being conducted outside of DoD, for example, in the National Institutes of Health. The Navy's dental research work and its relationship to that of NIDR was cited as a specific example.

In addressing the question of potential manpower reductions, the Committee found that a reordering of functions and transfer of activities were desirable with regard to the Naval Aerospace Medical Research Laboratory, the Human Factors Technology Division of NELC, and the Naval Medical Field Research Laboratory, Camp Lejeune, North Carolina. In other areas recommendations

were made for a rebalancing or increase in effort in certain activities of the Navy Health Research Center, the Naval Submarine Medical Research Laboratory and the Navy Training Equipment Center.

The Committee also recommended that collocation of the Naval Toxicology Unit (at Bethesda) with the Toxicology Division of the Air Force's Aeromedical Research Laboratory, Wright-Patterson AFB, Ohio, be considered. The extensive facilities of AMRL would then be immediately available to both units.

A major point was made of the need for an improved data base and management information system which would identify and permit analysis of all Navy medical and human resources R&D for management use. In addition, they recommended development of a common personnel data base combining medical, dental, personnel, and other information on individual members of the Navy for use in conducting longitudinal studies. Before any effort is expended in this direction, Privacy Act implications should be considered.

3.3 Overview of Air Force Study

The Air Force study was conducted by a committee which included Air Force military and civilian personnel and representatives from non-government, academic and industrial sectors. The Air Force representatives included both R&D and user personnel. The Air Force report was submitted in March 1975 (reference 5). The complete membership of the Committee is shown in Appendix F.

The Chapman Committee had also reviewed the laboratories to be addressed by the Air Force study. The Chapman Report findings were considered and concurred in by this study group. In consonance with the Chapman Report, the Committee recommended retention of the present organizational arrangements of the Aerospace Medical Division and the Air Force Human Resources Laboratory as being the most appropriate of several options considered. The Committee felt that the mutually supporting relationship among the Aerospace Medical Division's missions of medicine, education, and R&D was a highly beneficial one.

The study group agreed with the Chapman Report that the laboratories were already at a minimum number (three) and size. Management of the laboratories was considered to be strong although some concern was expressed for the availability of future replacements at the middle management level.

The same concern for overcentralization of R&D management was expressed as was expressed by both of the other Service study groups. Specific areas of existing, planned and desirable interdependencies were identified for both the Biotechnology Program of AMD and the R&D efforts of the AFHRL. Recommendations in this area were related to current DDR&E studies, and to existing and emerging tri-Service interrelationships. The general conclusion was that increased tri-Service interdependency can and should be sought. However, the need for a strong relationship between medical and human resources areas of research and development and corresponding activities of the individual Services' hardware laboratories was also acknowledged.

The study group supported the need for non-Technology Base funding for non-Technology Base work in these laboratories. They suggested that more use of the ROC (Required Operational Capability) procedure be made to document and fund development work in these laboratories as is already the case in the more hardware oriented disciplines. Other directed work such as maintenance and updating of selection and classification tests should be funded from the appropriate operating fund accounts.

The major customers for the R&D product from the AMD are the Systems Acquisition Divisions of AFSC, the Air Force Surgeon General, and organizations concerned with environmental quality and occupational safety. The relationship between the Life Support SPO and AMD was judged effective in assuring technology transfer to the Operating Commands. AMD relies heavily on a close relationship with other laboratories in AFSC for mutually supportive R&D. Increased management emphasis is needed to assure better communication with Product Divisions during the early design stages of systems acquisition, and with AFLC and the Operating Commands during modification and retrofit programs. AFHRL received strong endorsement from its customer representatives in the area of personnel research, training and development of simulator technology. USAF/DP stated that much of AFHRL's work in these areas was conducted as a result of directed requests for assistance on solving current operational

problems. AFSC's Aeronautical Systems Division stressed the major gains in awareness the SPOs have of HRL and their products and the high payoff potential through use of AFHRL capabilities in early system development. The need for continued balance between R&D on personnel requirements and system development was recognized by the Committee.

4. RESULTS OF ODDR&E STUDY

After the Military Departments completed and submitted the report of their individual studies, the ODDR&E staff, in conjunction with the study coordinating committee, performed an independent review of the Military Departments laboratory systems in addition to a critique of each of the Military Department reports. The principal questions addressed were the same as those posed for the individual Service studies.

4.1 Need For the In-House Medical and Human Resources Laboratories

In the report of the Physical Sciences and Engineering Laboratories Utilization Study (LUS), it was concluded that there are many things in-house laboratories can do, some things they should do, and only one thing that they are uniquely qualified to do, viz., provide technical input to military planning and decision making. A similar conclusion is valid with regard to the medical and human resources laboratories, especially in relation to their unique qualifications to advise military decision makers and planners on the human element of global defense operations. In addition, these laboratories are uniquely qualified to (1) advise system designers on man-machine interface, human stress constraints, selection, training, and use of operators and maintainers, (2) to provide advice on triage, care, evacuation and treatment of casualties, and (3) to conduct the necessary Research and Exploratory Development to maintain a defense related Technology Base in these areas.

4.2 Management of the Laboratory Complex

The management improvement recommendations contained in Section 4.2 of the Physical Sciences and Engineering Laboratories Utilization Study pertain equally well to the medical and human resources laboratories. The reader is referred to that report for a complete discussion of these recommendations. In general, they relate to improved personnel management practices with increased authority and flexibility for laboratory directors in

managing their personnel force, implementation of financial controls alone on manpower and closer integration of the laboratories into the decision making process of the Military Departments.

In addition to these general recommendations, this Study identified a need for better incorporation of these laboratories into the weapon system acquisition and personnel management processes and into the structure for policy-making when such policy affects the human element of the Military Departments.

There is a wide spectrum of opinion among the users of these technologies and the operational forces as to the value of the contributions made by the medical and human resources laboratories. In some cases this variance reflects the equally wide range of quality of interaction of these laboratories with the potential users. They are contributing significantly in some areas and not contributing in others, either through their own fault or by virtue of circumstances beyond their control. In other cases this lack of appreciation is due to inadequate product marketing. A better marketing effort should be undertaken by these laboratories to ensure not only that their current contributions are used, but also that the opportunities for making such contributions can be expanded.

4.2.1 Multi-Service Concerns

In each of the Military Departments, instances were cited of inappropriate funding for certain categories of work. With few exceptions, the work done by these laboratories is funded principally by the Technology Base, although some of the work performed should more appropriately be funded from budget categories 6.3, 6.4, and 6.5. It appears that in these areas particularly, it has been traditional to fund technical advisory service, data analysis and other non-Technology Base work, when it is assigned, out of Technology Base funds. It has been assumed that obtaining appropriate funding for the non-Technology Base work in these laboratories would be a very difficult task. This has been a self-fulfilling prophesy in that as time passed and the system became accustomed to funding these laboratories only with Technology Base funds, it in fact becomes more and more difficult to obtain any other type of funding. Examples include Advanced Development of vaccines, short term personnel and medical data analyses exercises to answer policy questions, and the maintenance and updating of selection and classification tests. The programs of each of the laboratories covered by this study should be reviewed with the objective of identifying that work which should not be funded by Technology Base funds and appropriate funding for

that work should be programmed. It is recognized that this transition may require more than one fiscal year.

The Army study recommended that a Joint Human Resources Research Conference be established to facilitate the coordination of human resources R&D among the three Services in a manner similar to that done by the Joint Medical Research Conference in the medical and life sciences area. While the other Services' studies do not make such a recommendation, the advisability of implementing this recommendation was discussed with representatives of the other Military Departments by the Coordinating Board and by the OAD(E&LS) staff. It was concluded that the implementation of this recommendation would be highly desirable. It is therefore recommended that a Joint Human Resources Research Conference be established with membership from each of the Military Departments, chaired by an outside consultant and with the Military Assistant for Training and Personnel Technology, ODDR&E, as the Executive Secretary.

An indictment reported in each of the Military Department reports concerned the use of the human resources laboratories as "job shops" by the operating personnel community. There is a tendency for the personnel community of the Military Departments to look upon the human resources laboratories as their technical services agencies, levying upon them requirements to perform short and mid-term projects often involving the analyses of existing data and answering various "what if" questions concerning the active military force. The answers to these questions are generally used as input to various policy decisions.

On the one hand, this practice is commendable; in fact, it is one of the ways in which these laboratories can participate directly in the decision making process - a practice recommended for strengthening elsewhere in this report. On the other hand, the manner in which these tasks are levied on the laboratories, and the source of funding used to accomplish them, are of considerable concern. At present, this work is generally performed out of Technology Base resources, thereby diverting these resources from their intended purpose. In addition, the number and frequency of these requests can be disruptive to the technology program planning of the laboratory director.

Our recommendations on this subject are as follows: First, it should be established as a matter of principle that these laboratories are technology laboratories, not analyses shops. It should be acknowledged that the rendering of assistance, appropriate data, and recommendations to the personnel policy decision makers is a legitimate and valuable function of the laboratories. And lastly, procedures to provide the resources required to accomplish this function from sources other than the Technology Base should be established. This is being partially accomplished by the Navy and Army but not by the Air Force.

The LUS study discussed at some length the urgent need to modify existing Civil Service practices and regulations insofar as they apply to R&D personnel and especially to those working in the laboratories. (See LUS Appendix E). In addition to the recommendations made in the LUS, two additional specific recommendations were generated by the present study. The first is that longer probationary periods be authorized for laboratory professionals. Such a change would lengthen the period of service before the employee would attain permanent employee status. The second recommendation suggests that professionals be employed on term contracts with renewal options to be granted at the discretion of the laboratory director. The benefit to be accrued by management is obvious. The current practices of NIH Post-Doctoral Fellowship Programs have been cited as an example of precedent for both.

A single program planning organization for human resources Technology Base work should be established in each Service. In the case of the medical laboratories, the program in each Service is integrated and planned by a single organizational entity with few exceptions. In the case of human resources in both the Army and Navy, there is no overall integrated program planning; in the Navy the planning lacks even a semblance of partial integration.

It should be recognized that the medical and human resources laboratories have as the subject of their work a common entity - man. Both communities study man, his reaction to his environment, and the limits of his performance. Different approaches are used involving differing scientific disciplines; different aspects of man are emphasized. The dividing line between the technical preserves of each of these communities varies from Service to Service and among organizations within a given Service.

Rather than press for standard divisions of effort among the three Military Departments, which in itself would have to be arbitrarily selected, it is recommended that each Military Department develop mechanisms for the joint planning of its Technology Base work in these two areas, especially in the area of human factors, which is the area of closest interface between the medical and human resources communities.

Each of the three Services operates helicopter aircraft. The Army has the principal investment in helicopters although the Navy and Air Force also have significant helicopter operations. The Army has established its helicopter training center at Fort Rucker, Alabama. The Air Force has consolidated its helicopter training with the Army at Fort Rucker while the Navy has continued to conduct its own helicopter training, although it is understood that consideration is being given to collocating at Fort Rucker with the Army and Air Force. Within the Army, the aviation medicine research support of helicopter air crews is conducted at the Army Aeromedical Research Laboratory, Fort Rucker. Training and other human resources related R&D are also conducted at Fort Rucker by an ARI detachment with some additional work being performed by HEL. The Fort Rucker complex represents the major center of human related helicopter R&D in the Department of Defense. Some closely related work in this area is conducted by the Navy and Air Force at NAMRL, NETC, AMRDC, AMRL, AFHRL, and ATDA.

Human research in helicopter operations is becoming increasingly more important with the advent of nap-of-the-earth (NOE) operations. The Army has developed a 5 year helicopter aircrew performance enhancement program under the auspices of the Army Research Institute which attempts to integrate the medical and human resources aspects of helicopter operations. The other Services have no such comprehensive plan and in view of their relatively minor role in this area, that is as it should be.

It is recommended that the Army be designated lead Service for the conduct of all medical and human resources Technology Base work associated with the human aspects of helicopter operations. An R&D plan for this area should be developed by the Army to coordinate the activities effectively within the Army organizations, such as the Army Aeromedical Research Laboratory, ARI, and HEL, and among the Air Force and Navy. A focal point should be established with appropriate authority for reviewing, approving, and integrating proposed projects in this area. The Navy and Air

Force should not engage independently in this area except by incorporation of their work in the Army master plan. It is recognized that the Navy and Air Force have expertise which can readily be applied to this problem area in concert with the Army developed plan.

4.2.2 Army Laboratory Management

In addition to the recommendations made by the Army Study Group and concurred in by the OSD staff, and those multi-Service recommendations involving the Army, several additional recommendations for Army action follow:

- o The Army should formally designate lead laboratories in the medical and human resources areas. This has already been done in the physical sciences and engineering laboratories. An informal arrangement of laboratory specialization has been in existence for **some time**.

- o The Army should ensure that the Director of the lead laboratory in a specific area participates in the selection and monitoring of the associated contract program. As an example, in the Medical R&D Command, all contracts are let from the Command Headquarters, and no contracts are let by the subordinate laboratories. It appears that there is an informal arrangement whereby the functional director in the Headquarters consults with the director of the associated laboratory in developing the contract program. While no specific difficulty has been identified with this arrangement, we feel that it should be formalized to ensure its preservation.

- o The program of the Biomedical Laboratory, Edgewood Arsenal, Aberdeen Proving Ground, should be "purified" to eliminate any work which is considered to be unacceptable to the Army Surgeon General for ethical reasons and the laboratory then reassigned from DARCOM to the Army Medical R&D Command. The **small amount** of work eliminated from the Biomedical Laboratory program should be reassigned to the other DARCOM development laboratories.

- o In the human resources area the two principal organizations planning and executing the program are ARI and HEL. There is no visible integration of the work of these two organizations. ARI reports to the DCSPER on Army staff and HEL reports to Headquarters DARCOM. Similarly, it appears that ARI visualizes its responsibilities as Army-wide while HEL limits its activities to

support of the DARCOM programs. There is an urgent need to provide in the Army a focal point for common program planning and execution at the laboratory level in human resources similar to that provided by AMRDC in the medical area. It is therefore recommended that a single organization with a clear charter to serve as central focal point in the Army for planning and executing human resources R&D and coupling its results to Army-wide problems (to include personnel, training concepts, and doctrine and materiel acquisition) be established out of existing laboratories (HEL and ARI). It is further recommended that this single organization should be assigned to the DARCOM with Army staff responsibility placed within the DCSRDA. It is felt that these changes would engender greater involvement of ARI activities in the weapon systems/materiel acquisition process while maintaining the close interaction developed by HEL in the past.

- o The Army should acknowledge and actively pursue the concept of interdependency and participate in the follow-on effort to identify and agree to specific interdependency areas and lead Service responsibilities. (See section 4.3.)

4.2.3 Navy Laboratory Management

In addition to the recommendations made by the Navy Study Group and concurred in by the OSD staff, and those multi-Service recommendations involving the Navy, several additional recommendations for Navy action follow:

- o The development and maturing of the newly created Naval Medical R&D Command should be continued. The establishment of this Command was a significant step forward in integrating and coordinating the work of 10 Navy medical laboratories.

- o NMRDC should be allowed, and in fact required, to participate in the selection of medical research contracts by the Office of Naval Research. At the present time, there is little evidence to indicate that active and full participation now exists.

- o The Naval Biomedical Research Laboratory, Berkeley, California, should be terminated as a Navy laboratory. In view of the nature of the manning of this laboratory (20 Federal employees and 100 contract employees of the University of California), the relatively large amount of outside work accepted - about 20% - (even a greater share of outside work might result if it were

a non-defense laboratory), and its existence outside of the NMRDC which coordinates the work of 10 other Navy medical laboratories, coupled with the fact that there are already such a large number of Navy medical laboratories, has led to the conclusion that the future of this laboratory rests in its divorce from Defense sponsorship and its association with either a non-defense Federal Department, such as HEW, or with the University of California. Such a transition should not occur precipitously and should be accomplished in a manner that will cause the least disruption to the work underway. A transition planning group should be established which, in addition to its main objective of planning the transition of the laboratory to other sponsorship, will identify those specific work units in the area of infectious diseases that should be transferred to the Army Institute of Infectious Diseases at Fort Detrick, Maryland.

o The Medical Field Research Laboratory, Camp Lejeune, should be converted from an R&D funded research facility to an O&M funded field medical unit. The principal RDT&E function of this laboratory is the conduct of field tests of personnel equipment for the field Marine. A small amount of research is also performed. The extent of the program no longer justifies the maintenance of this facility as an R&D organization. It is recommended that the laboratory be converted into a field medical unit, operationally funded but retaining the capability to host, on an "as-needed" basis, test and evaluation teams from other development laboratories. The small program currently conducted at this laboratory should be transferred either to another Navy laboratory or to the Army's Natick Research and Development Command.

o The Navy Toxicology Unit at Bethesda should be relocated to be collocated with the Air Force program at the Aeromedical Research Laboratories, WPAFB. This collocation should allow for a more effective use of the small Navy resources in this technical area and will cause a better utilization of the existing Air Force facilities at AMRL.

o It is recommended that the Navy increase its emphasis in submarine medicine and in subsurface human factors R&D. The Navy Study Group observed and the OSD Study Group concurs that the Navy is applying a disproportionately small share of its available RDT&E resources in the area of submarine medicine, especially in view of the Navy's unique responsibilities in this area.

o Considerable concern exists over the dispersion of the Navy's aviation medicine R&D program among three separate facilities - the Navy Aeromedical Research Laboratories at Pensacola, Florida, the NAMRL Detachment at Michaud, Louisiana, and the Crew Systems Department of the Naval Air Development Center, Warminster, Pennsylvania. The facility at Michaud is collocated with the NASA facility at that location. It is the beneficiary of considerable support by NASA (i. e., computer support) which makes it cost effective at this time. Its program is based on a five-year program of work on the human effects of impact. It is our understanding that planning is now underway for a follow-on responsibility for this facility in the area of surface wave effects on the human operator. Information received informally indicates that the NASA support currently enjoyed may no longer be available in the next few years. This possibility, coupled with the dispersion of the aviation medicine work among three facilities, emphasizes the need for an extended plan for the discharge of the Naval aviation medicine program. It is recommended that the Navy prepare a five-year plan for Naval aviation medicine and that this plan be coordinated with the Air Force which conducts the major program in this area. The plan should include a detailed review of the future of the NADC Crew Systems Department and the NAMRL Detachment at Michaud, Louisiana.

o The Navy should develop NPRDC as the responsible agent for planning and coordinating the Navy's 6.2 and 6.3A efforts in human resources to include the human factors functions. It should be organizationally reassigned from the Bureau of Personnel to the Director of Navy Laboratories. The programs of the Human Factors Division of NELC, the Research Division of NTEC, and the selection and training work of NAMRL should be placed under the control of NPRDC to assess the value of these current programs and to plan an integrated follow-on effort with the work assigned to the appropriate facility for accomplishment. All Systems Command funded human resources 6.2 and 6.3A work should be coordinated with NPRDC. Plans should then be formulated to transition these programs with NPRDC for management.

o NPRDC should participate with ONR in planning the 6.1 human resources program. NPRDC should consider the establishment of additional field units collocated with users, for example, in the area of flight training.

- o The Navy should acknowledge the concept of interdependency and participate in the follow-on effort to identify and agree to specific interdependency areas and lead Service responsibilities (See Section 4.3).

4.2.4 Air Force Laboratory Management

- o The already small number (three) of the Air Force medical and human resources laboratories leaves little opportunity for further consolidation or realignment. In addition to the recommendations of the Air Force study, and those multi-Service recommendations involving the Air Force with which OSD concurs, the following additional recommendations are made:

- o The DCS Personnel has the responsibility for promulgating Requests for Personnel Research (RPRs) under the authority of AFR 80-51. The RPRs are prioritized and forwarded to DCS/R&D for action. Experience indicates that a wide range of RPRs from short term data analysis requirements to longer range technology efforts are submitted under this regulation. About 45% of the active AFHRL work units support RPRs and require approximately 50% of the total laboratory S&E manpower. AFR 80-51 provides no direct method for funding this work, thus, the efforts resulting from RPRs are funded with Technology Base funds. While the role of the DCS Personnel is clearly recognized in the requirements and implementation of personnel related R&D, the management of R&D to include prioritization of effort should remain within the R&D community. AFR 80-51, as presently constituted, makes long range technology planning difficult. It is recommended that AFR 80-51 be revised (1) to make RPRs part of the overall data base for technology planning by AFHRL, not the driving programmatic force; (2) to provide DCS Personnel clear responsibilities in the generation and evaluation of requirements in personnel related RDT&E; (3) to provide the DCS Personnel a clear role in the implementation of personnel related R&D products; (4) to assign AFHRL the authority, subject to the review and approval of higher headquarters, to develop a Technology Base program based on RPRs and all other planning information, such as Technology Needs (TNs), PPGM, and laboratory plans; and (5) to fund RPRs for analysis or other non-Technology Base efforts, on a cost reimbursable basis, with studies and analysis funds (6.5) or O&M funding.

- o Appropriate non-Technology Base funding should be provided to the medical and human resources laboratories for any non-Technology Base work assigned to them.

o The Air Force should acknowledge the concept of interdependency and participate in the follow-on effort to identify and agree to specific interdependency area definitions and assignment of lead Service responsibilities (See Section 4.3).

4.2.5 Armed Forces Radiobiology Research Institute, Bethesda, Maryland

AFRRI of the Defense Nuclear Agency is operated under the provisions of DoD Instruction 5105.33 which prescribes the Institute's responsibilities for conducting research in radiobiology and nuclear weapons effects. Additional responsibilities in the nuclear effects area were assigned to AFRRI by OJCS memorandum dated 15 May 1975, "Radiation Casualty Criteria for Land Battlefield Targets."

The FY 75 budget of AFRRI is \$3.73M of which \$0.755M is reimbursable from other agencies (Navy, Army, Air Force, NIH, DOT). One hundred percent of the funding is spent in-house with the justification being the uniqueness of the AFRRI facilities. Principle among these "unique" facilities are the several nuclear reactors and associated instrumentation.

During the past decade, the requirement for radiobiology and nuclear weapons effects research has diminished. As a result, the Institute has been forced to seek funding for medical research that falls within the competence of the assigned staff. These areas include behavioral toxicology, pathology, physiology, neurophysiology, pharmacology, neurochemistry and radiology. Recent discussions with the management of the newly created Uniformed Services University of the Health Sciences has resulted in a tentative agreement to devote a portion of AFRRI's professional man-hours and laboratory spaces to the University on a reimbursable basis. It is felt that the University will utilize AFRRI as the base facility for its training programs in neurophysiology, pharmacology, neurochemistry and radiology just as it will look to the Armed Forces Institute of Pathology for training in anatomy, chemistry, and pathology.

The only remaining in-house laboratory capability in the Department of Defense for radiobiology and nuclear weapons effects on humans other than AFRRI is the USAF School of Aerospace Medicine's (USAFSAM) Department of Radiobiology. USAFSAM's work differs from that conducted at AFRRI in that it addresses low dose, low-dose rate gamma exposures and their effects on crew performance in Air Force systems. This dose/

dose rate regime has been identified by the operational commands as the principal area of Air Force interest at this time. USAFSAM has a competent modeling capability for generating codes describing the radiation effects on the human operator and his performance decrement as a function of mission segment. AFRRRI's work on the other hand is concentrated on high dose/ high-dose rate exposures and the assessment of relative biological effectiveness (RBE) of mixed gamma and neutron exposures.

It appears that DNA's need for AFRRRI will continually decline. Continuing to devote an increasing proportion of AFRRRI's capacity to non-DoD work to compensate for the decrease in DNA support is not an acceptable strategy for an in-house DoD laboratory. As a result, the following alternatives are proposed:

- o AFRRRI be removed from assignment to the Defense Nuclear Agency and reassigned to the Uniformed Services University of the Health Sciences as a combined research and training facility. The residual DNA program in radiobiology and nuclear weapons effects could be performed at appropriate laboratories with AFRRRI designated as the lead laboratory. Assignment of AFRRRI to the University would maintain its tri-Service character, provide the University with a much needed training and research facility, allow the AFRRRI staff to expand its spectrum of research activity, motivate the Surgeons General to assign competent research personnel to AFRRRI and will relieve DNA of the responsibility for managing a single subordinate laboratory. The complications occasioned by university rules and procedures for faculty appointments need to be addressed in more detail.

- o AFRRRI be offered as a National Facility to an appropriate non-DoD agency, e. g., ERDA, for joint use by all Federal Agencies having a need or interest, e. g., ERDA, HEW, DoD, NSF, DOT, EPA. Since an increasing proportion of AFRRRI's work is non-DoD funded, this arrangement would facilitate continuation of this trend.

- o Close the laboratory.

It is inappropriate for AFRRRI to continue on its present course. While the study group feels that the transfer of AFRRRI to USUHS is the most attractive alternative, it feels that this question should be examined in more detail. A follow-on working group should be established to determine the most productive future

mission and organizational placement for AFRRRI. (One caution: An expanded mission for AFRRRI should not be "invented" at the expense of existing well managed programs in the Military Departments.)

4.3 Interdependency

Interdependency may be defined as the practice of avoiding unwarranted duplication of R&D by relying on another Service or Agency for part of the effort in a particular area of the Technology Base. This concept has been supported by ODDR&E for some time. The study group feels that the medical and human resources areas are particularly amenable to the exercise of the interdependency concept.

The specific missions of the Military Departments place their members in different environmental and operational situations resulting in different human responses. These differing environmental circumstances involve differing combinations of a small set of environmental parameters, i. e., vibration, acceleration, thermal, ionizing radiation, etc. As a result, over the years each of the Military Departments has tended to specialize in certain specific segments of the spectrum of each of these environmental parameters. This is a de facto form of interdependency. A formal effort is now required to expand these areas of interdependency, plan the Technology Base in these areas in a more integrated fashion and take maximum advantage of the limited amount of research facility funds currently available.

Attempts were made to develop a list of candidate interdependency areas along with a suggested lead Service for each area. A lead Service for this purpose is defined as that Service which leads the planning and coordinating of all DoD Technology Base effort in a given area and usually conducts the major portion of that program. While the subject of interdependency was stressed from the very beginning of this study and while the actual accomplishment of increased interdependency in these areas is considered essential, more time and attention is required to implement this recommendation. It is strongly recommended that the concept of interdependency be acknowledged and pursued actively by the Military Departments. It is further recommended that responsibility for reaching an agreement on these specific interdependency areas and the associated lead Service assignments be given to the Technology

Base planning group described in Section 4.6.

4.4 Laboratory Size

The total manpower assigned to these laboratories for Fiscal Years 71-74 is shown in Appendix J. A total of fewer than 7,000 personnel is involved. This represents approximately 10% of the total defense in-house laboratory manpower. In view of the importance of the human element in defense weapon systems and in view of the unique environment into which the military man is placed, this allocation of R&D resources is judged to be inadequate. If the 200 plus manpower spaces associated with the Human Resources Research Organization (HumRRO, formerly an Army FCRC) are added to the FY 71 totals, as they should be for consistency, it can be seen that the total manpower assigned to these laboratories has, in fact, decreased over the three year period. As a result, there is no justification based on total laboratory size for levying manpower reductions on these laboratories and no across the board reduction is recommended.

4.5 In-House/Contract Ratio

The percent of the 6.1 Research and 6.2 Exploratory Development effort performed in-house by the medical and human resources laboratories of the three Military Departments is shown in Table 4-1. In general, from 60 to 70% of the medical work is performed in-house while in the human resources area, generally, a lower percentage of approximately 40-55% exists. An apparent exception to this percentage range is the Air Force Human Resources program for Fiscal 1973 and 1974. The departure is related to the Air Force policy to fund all in-house civilian salaries for their laboratories from a single 6.2 support project which abnormally increases in-house 6.2 funding. In addition, the Air Force Human Resources Laboratory has maintained a substantial 6.3A Advanced Development Program, all of which is on contract. Consequently, these ratios are considered to be an appropriate mix of these technical areas.

4.6 Medical and Human Resources Technology Base Planning

Both the medical and human resources laboratories have as the object of their studies a common entity - man. Different approaches are used, involving different scientific disciplines,

TABLE 4-1

IN-HOUSE % OF 6.1 AND 6.2

ARMY	<u>71</u>	<u>72</u>	<u>73</u>	<u>74</u>
MEDICAL	64	64	64	64
HUMAN RESOURCES	74	50	65	40
NAVY				
MEDICAL	65	59	63	58
HUMAN RESOURCES	46	49	45	42
AIR FORCE				
MEDICAL	71	71	69	67
HUMAN RESOURCES	56	57	66	79

to determine his reaction to his environment, the limits of his performance, a set of norms for his various characteristics, and the means for returning him to a normal state when he has exceeded these norms. Consequently, a common, coordinated planning strategy for conducting this segment of the Defense R&D program is essential to the optimum use of available resources. Accordingly, it is recommended that such a strategy be developed and a mechanism established to implement it. Such a mechanism, the Medical and Human Resources Technology Base Planning Group is described in the following paragraphs.

4.6.1 Medical and Human Resources Technology Base Planning Group

If the R&D programs of the medical and human resources laboratories can be divided into two major categories, i. e., Technology Base (6.1, 6.2 and 6.3A) and Systems Support (to include all non-Technology Base work), the following matrix can be used to divide the planning, programming, execution and coupling functions for these two categories of work.

	Planning	Programming	Execution	Coupling
Technology Base				
Systems Support				

In the Systems Support area the work is by definition closely aligned to specific Service needs. Therefore, the planning, programming, and execution of these projects and the coupling of the results to the user are almost entirely a single Service function (with the exception of specific multi-Service projects). OSD enters in the planning and in the programming function as it must provide planning guidance and approve the proposed Program Objective Memoranda (POMs), budget and apportionment requests for these efforts. In the Technology Base, however, a different situation exists. Since Technology Base work has wide applicability, it should be planned on a tri-Service basis with ODDR&E participation to facilitate the development of a comprehensive and timely program that is not needlessly duplicatory.

Programming for the work is again principally a Service responsibility with the same participation by ODDR&E as is indicated for systems support work. Execution of the Technology Base work is again principally a single Service responsibility. The coupling of Technology Base results is a function of both the individual Services and ODDR&E. These relationships can be summarized by completing the above matrix, using the following symbols:

T - Tri-Service
 D - ODDR&E
 S - Single Service Responsibility

	Planning	Programming	Execution	Coupling
Technology Base	T+D	S(+D)	S	S/T/D
Systems Support	S(+D)	S(+D)	S	S

With this in mind, an effective mechanism can be established to perform the ODDR&E/tri-Service planning function for the medical and human resources Technology Base effort.

The proposed planning mechanism would take the form of a Medical and Human Resources Technology Base Planning Group, chaired by the AD(E&LS) in ODDR&E, and have representation from both the medical and human resources areas of the three Military Departments. Reporting to this Planning Group would be a series of subgroups in major technical subareas, each of which would have representation from each of the Military Departments and might be chaired by the lead Service for that technical area. Initially, it is recommended that thirteen subgroups be established.

- o Human Factors
- o Environmental Physiology
- o Biodynamics (to include acceleration, vibration, and impact)
- o Bioacoustics
- o Dental Research
- o Radiobiology (to include ionizing and non-ionizing radiation) Will include AFRRRI as a member

- o Infectious Diseases (to include medical aspects of chemical and biological defense)
- o Surgery and Combat Medicine
- o Health Care Technology
- o Environmental Quality and Toxicology
- o Training and Education
- o Training Devices and Simulation
- o Personnel, Manpower and Contemporary Issues

Each of the subgroups would be responsible for jointly planning all DoD Technology Base work (6.1 and 6.2) in its area of responsibility. This planning could be done on a semi-continuous basis throughout the year with presentation of its planned program to the parent Planning Group twice a year, at the budget review and at apportionment. It would be essential that the Military Department representatives to these subgroups include the same individuals who are in a position to carry through their recommendations by programming of resources to the proposed work. The parent Planning Group would then be responsible for reviewing these plans and integrating them where necessary. This same Planning Group would be the mechanism through which the medical and human resources TCPs are written and updated. The subgroups would organize the Topical Reviews.

There is also a need to emphasize the importance of obtaining regular peer review by an outside-the-DoD or DoD group of experts in the development of plans and programs. Such a review will insure the scientific and technical competence of the products of the work as well as the operational appropriateness.

The Joint Medical Research Conference (JMRC) would be retained as a monthly review and coordinating mechanism and a counterpart Joint Human Resources Conference would be established. (See paragraph 4.2.1.) All other tri-Service integrating and planning activities in the medical and human resources Technology Base programs would be either phased out or merged into the subgroups. An organizational chart for the Medical and Human Resources Technology Base Planning Group may be found at Appendix K.

4.7 Continuing Concerns

There are some areas touched upon in this study that were found to be essential for continuation at this time but which bear reexamination at a later date. The three areas are: Dental

Research, Arctic Medical Research, and Overseas Medical Research Units.

4.7.1 Dental Research

Both the Army and Navy conduct dental research programs directly related to Defense problems. The Air Force terminated its active dental research program in FY 70 (they now conduct a "technology watch" on R&D performed elsewhere). A review was conducted to assess the degree of relevance of these programs, the degree to which they overlap, if any, and the need for the facilities involved in the work.

Army dental research primarily addresses the treatment and restoration of maxillo-facial injuries. Specific aspects of the work include development of new materials as well as methods and techniques that will improve the probability of recovery from these injuries at the minimum cost. This work is important as evidenced by the latest combat statistics which show a 15% incidence of maxillo-facial injuries requiring hospitalization. Fifty-five percent of these were wounds of the mandible which require extensive and coordinated reconstruction and rehabilitation. In view of the frequency of injury, the size of the combat ground force, the nature of the treatment required and the expense involved, the Army's program has significant potential for payoff.

The solution of these problems will not come from the civilian sector. The National Institute of Dental Research of the NIH has a large program but it is addressed exclusively to the prevention and treatment of dental disease in children.

The Navy program is clinically oriented and primarily focused on the study of oral disease problems in young adults (the largest segment of the Navy and Marine Corps). The objective of the program is the development of effective and least costly procedures for the prevention of dental disease in this population and for the economical and speedy treatment of disease under Navy environmental conditions when such disease occurs. An example of the differences in dentistry between the young adult and children populations is the recent findings by the Navy R&D program that resin sealant coatings developed by NIH to prevent dental decay in children are not effective in Navy populations.

The facilities involved in the Army and Navy dental research programs are:

- o The Army Institute of Dental Research, Walter Reed
- o The Naval Dental Research Institute, Great Lakes
- o The Dental Science Department, NMRI, Bethesda

Considerable informal coordination is carried out routinely with other agencies performing dental research. Quarterly meetings are held between the research managers and the dental staff representatives of the three Services. Army and Navy liaison members sit on the study section of NIDR and Army and Navy observers have been appointed to the National Dental Research Advisory Council. The effectiveness of this coordination with non-DoD agencies is evidenced by a 30 July 1973 communication from the Director of NIDR to the Navy Surgeon General which states in part, "It is indeed gratifying to note the continuing leadership role played by your department in those vital areas of dental research critical to the advancement of dental care delivery systems. The activities are particularly significant at this time as they complement so effectively the programs of NIDR."

It is recommended that the interagency coordination activities continue. In addition, a Dental Research Coordinating Subgroup has been proposed under the Medical and Human Resources Technology Base Planning Group (See Section 4.6) with representation from the three Services with the objective of coordinating the Army and Navy dental research programs and to ensure that these programs are addressing the highest priority dental problems across the three Services. This group should be composed of representatives of the three Surgeons General, the Dental Research Division of AMRDC, and the Dental Health Division of NMRDC. Participation by the Directors of the Dental Research Laboratories should be decided upon after further study.

In addition, at least one session of the Joint Medical Research Conference each year should be devoted to the subject of dental research to include a report to the JMRC by the Defense Dental Research Coordinating Subgroup.

4.7.2 Arctic Medical Research

A review was made of the need for retention of both Army and Navy research facilities in Alaska.

The former Army Arctic Medical Research Laboratory Alaska (AMRLA) at Fort Wainwright was discontinued 6 January 1976. It has been superseded by the Arctic Medical Research Facility (AMRF), a detachment of ARIEM. This facility, located adjacent to Bassett Army Hospital, is on caretaker status in the summer months and serves as a base of operations for ARIEM research teams during winter exercises in the area. The emphasis within the ARIEM program will continue to be on the etiology and treatment of cold injury.

The Point Barrow facility of the Navy on the other hand is located near the Arctic Ocean. Its program is principally devoted to the geophysical and earth sciences with particular emphasis on the Arctic Ocean and its ice cover. A minor amount of biological science research is conducted by contract investigators using a colony of captured wild arctic animals as objects of study. There is no facility designed for human studies at Point Barrow.

It was determined that relocation of the Army program to Point Barrow is not feasible. Relocation of the small Navy Arctic Biology program at Fort Wainwright was not evaluated.

It is recommended that this area be examined further with the objective of formulating a coordinated plan of work addressing established goals.

4.7.3 Overseas Laboratories and Units

An assessment was made regarding the continuing need, the productivity and the return on investment being gained by the Navy laboratories: NAMRU-2, Taiwan; NAMRU-3,

Egypt; NAMRU-5, Ethiopia; and the units of the Walter Reed Army Institute of Research in Thailand, Brazil, Malaysia, and Kenya.

In general, it was found that the laboratories and units served useful purposes for U.S. forces for the following reasons:

(1) They provide a continuing means for maintaining a disease watch on the geographic area in which they are found; (2) They are an excellent avenue for assuring timely dialogue and cooperative efforts with the local experts of the host countries; (3) They provide excellent training for U.S. scientists whose normal academic curriculum does not include emphasis on diseases, sanitation engineering and environmental hazards for areas outside the United States; and (4) They provide the social value of having U.S. medical scientists providing special expertise and support for problems that are confronting the host country.

It was concluded, however, that the cost-effectiveness of the currently existing laboratories and units should be challenged through reexamination regularly to ensure that the benefits to be gained continue to warrant the investment. It is recommended that the reexamination be conducted every five years. Included in the reexamination should be the benefits to be gained directly by the DoD as well as those of value to other Federal Agencies and Departments. This analysis should also ensure that the maximum return is being obtained from the programs being conducted.

5. SUMMARY OF RECOMMENDATIONS, SERVICE RESPONSES AND FOLLOW-UP ACTION

The draft report of the Medical and Human Resources Laboratory Utilization Study, which consisted of Sections 1-4 and Appendices A-K, was forwarded to the Services and the Defense Nuclear Agency (DNA) for review and comment on 16 April 1976. All Services and DNA completed their review of the report and forwarded their respective response by early June 1976.

The Army response (Appendix L) concurred with the major conclusions and recommendations of the report. The Army also concurred in principle with the majority of the specific recommendations. The ODDR&E staff met with Army representatives to

discuss areas of agreement and disagreement. The LUS recommendations, Army response, and DDR&E recommendation and follow-up action required are presented in 5.1, Inter-Service Recommendations, and 5.2, Army Recommendations, which follow. A DDR&E memorandum for the Assistant Secretary of the Army (Research and Development), 27 September 1976, Subject: Medical and Human Resources Laboratory Utilization Study; Follow-Up Actions, is included as Appendix P.

The Navy response (Appendix M) to the draft report included an evaluation of the report and proposed actions to the recommendations of the report. The Navy made several specific proposals for management changes in the Navy laboratory structure. The ODDR&E staff met informally with Navy staff representatives to review the Navy evaluation of the report and the implementation plan for the recommendations. The LUS recommendations, Navy response, and DDR&E recommendation and follow-up action required are presented in 5.1, Inter-Service Recommendations, and 5.3, Navy Recommendations, which follow. A DDR&E memorandum for the Assistant Secretary of the Navy (Research and Development), 27 September 1976, Subject: Medical and Human Resources Laboratory Utilization Study; Follow-Up Actions, is included as Appendix Q.

The Air Force response (Appendix N) to the draft report expressed agreement with the major inter-Service conclusions and recommendations, and general agreement with the Air Force program descriptions and recommended improvements. However, disagreement was expressed with regard to several recommendations which the Air Force perceived would increase ODDR&E direct control of Technology Base programs. The ODDR&E staff met with the Air Force staff in an attempt to understand and resolve the major points of disagreement. The LUS recommendations, Air Force response, and the DDR&E recommendation and follow-up action required are presented in 5.1, Inter-Service Recommendations, and 5.4, Air Force Recommendations, which follow. A DDR&E memorandum for the Assistant Secretary of the Air Force (Research and Development), 27 September 1976, Subject: Medical and Human Resources Laboratory Utilization Study; Follow-Up Actions, is included as Appendix R.

The Defense Nuclear Agency response (Appendix O) did not concur with the final conclusion and proposed alternatives for the disposition of the Armed Forces Radiobiology Research Institute (AFRRI). DNA instead recommended that AFRRI remain a subordinate unit of DNA. Detailed treatment of this issue is presented in 5.5, Armed Forces Radiobiology Research Institute.

5.1 Inter-Service Recommendations

o LUS Recommendation: Review Medical and Human Resources programs with the objective of identifying work which should not be funded by Technology Base funds. Program appropriate funding for the work identified. Establish as a matter of principle that these laboratories are technology laboratories, not analyses shops. Acknowledge that rendering assistance and providing appropriate data and recommendations to the personnel policy makers is a legitimate and valuable function of the laboratories. Establish procedures to provide the resources required to accomplish this function from sources other than the Technology Base.

-- Army Response: OMA funding is provided to some USAMRDC units to cover costs of providing support. Army has procedures for budgeting/reimbursing for non-tech base work.

-- Navy Response: "Concur. The Navy has well established procedures for reimbursing its laboratories with appropriate funds for work that does not contribute to the technology base." In response to this recommendation, however, a SECNAV Notice will be issued prior to 1 November 1976 citing this concern and reinforcing the need for continuing attention to and compliance with established procedures and practices.

-- Air Force Response: "We concur with the general recommendation concerning reimbursement funding for non-technology base studies. However, we disagree with the concept of a Management and Support category within the laboratory program structure. As a management tool, the introduction of a Management and Support category invites administrative and funding adjustments that are not cost-effective relative to the level of support rendered. Moreover, it introduces the possibility of locking a small cadre of laboratory personnel into a support function at the price of technology base work. Action is being taken to change AFSC Regulation 172-2 to provide more flexibility in obtaining reimbursement of **salaries** and other direct costs not associated with the exploratory development activity."

-- DDR&E Recommendation and Action

Required: Accept Navy position; for Army and Air Force, phase funding changes to be completed by FY 1979 POM submit. Request implementation plan by 19 November 1976.

o LUS Recommendation: Develop mechanisms within each Military Department for the joint planning of its Technology Base work in Medicine and Human Resources.

-- Army Response: "The idea has merit. The Medical and Human Resources Technology Base Planning Group as a common, coordinated, planning mechanism or vehicle could be most useful if it were functioning in lieu of the lead Service concept for most major technical sub areas. This notion tracks very well with the proposal of the Tri-Service Human Factors Topical Review Working Group to establish a Human Factors Advisory Group which would review and categorize the area, and promote cooperative, coordinated, collaborative and non-duplicatory efforts, identify technology gaps, update TCPs, and guide preparation for topical reviews."

-- Navy Response: "There are several major features to this recommendation, each of which requires comment:

(1) Interdependency. The Navy favors interdependency, a Joint Personnel and Training R&D Conference, the existing Joint Medical R&D Conference and the examination of specialized areas by those who know them best to avoid duplication. We favor the continuation of such coordination practices as the Technology Coordinating Paper, the topical review, and the tri-Service plan in special areas as identified by those mechanisms.

(2) Lead Service. The Navy opposes this suggestion because history has shown that funds tend to dry up in the non-lead Services, and the lead Service does not look after the interests of the others. The case of the Army and simulation has already been mentioned.

(3) Joint Medical and Human Resources Planning. As described before, there is not sufficient common interest to warrant this on a comprehensive and continuing basis. The individuals might meet a few times, but then the system would die. The Navy has proposed a system of planning its own Personnel and Training work that includes medical participation.

(4) Chairmanship by the Assistant Director (Environmental and Life Sciences) in ODDR&E. The Navy is opposed because the need for its work is validated by the sponsors in OPNAV. The proposed system would cut the program away from its parent Service roots.

(5) Peer Review. The Navy has an informed and effective peer review system in the Navy Research Advisory Committee.

(6) Retention of the Joint Medical Research Conference. Concur."

"Thus, while the need for a mechanism to ensure tri-Service coordination of medical and human resources R&D program planning is recognized, the establishment of an ODDR&E Technology Base Planning Group to perform this function is considered undesirable and unwarranted. This position is further supported by the following considerations:

(1) Establishment of the Planning Group would essentially transfer authority for medical and human resources R&D planning from the management offices and commands of each Service to ODDR&E, leaving individual Services with responsibility for implementing higher level decisions and executing an ODDR&E-devised program. The separation of authority from responsibility is an undesirable management practice.

(2) No single group, composed of part-time representatives from each Service, will be able to oversee and control R&D planning for all three Services. Such control properly resides within the Services where R&D capabilities, objectives and requirements are thoroughly understood and where the expertise required for effective planning is located. Moreover, it is unrealistic and unworkable to propose that "it would be essential that the Military Department representatives to these subgroups include the same individuals who are in a position to carry through their recommendations by programming of resources to the proposed work." Ultimate authority for allocation of resources does not reside with persons responsible for individual program areas (e. g., Surgery and Combat Medicine, Radiobiology, Infectious Diseases, etc.). Their recommendations are always subject to review and approval by one or more superiors. The proposed procedure would result in principal activity by the ODDR&E staff further reducing the interactions with the users and Service relevancy.

(3) Existing R&D panels (such as the Joint Medical Research Conference, the Tri-Service Panel on Electromagnetic Radiation, and the Tri-Service Panel in Impact, Acceleration and Vibration Research, as well as that for computers in training and education), which were convened by DoD expressly to prevent needless duplication of effort and to ensure inter-Service communication in program planning, should be given a chance to succeed and, where the need exists, expanded to other technology areas. Such panels, established for each technology area being addressed by more than one Service, cannot only be alert to program redundancies but can ensure that program content is within each Service's capabilities and adequately responsive to its operational requirements.

We regard an annual in-depth program/budget review, consistent with current practice, involving the joint participation of appropriate R&D managers of the three Services and appropriate ODDR&E representatives, as a preferred alternative to an ODDR&E Technology Base Planning Group. Service-approved program plans, considering the recommendations of Tri-Service panels and consistent with TCP guidance, would be presented at the annual reviews. Obvious inter-Service overlaps in program content and program deficiencies would surface before or during the reviews and an opportunity would be afforded to develop jointly plans which adequately address the unique requirements of each Service. This procedure would involve ODDR&E personnel fully in the coordination and decision-making process, while at the same time ensure the participation of persons responsible to the management of the medical and human resources R&D programs of the three Services.

We can envision no significant advantage to "joint planning" of all medical and human resources technology base work. Little benefit would accrue by having a joint planning group address such diverse technology areas as the prevention of malaria, occupational aptitude testing, treatment of septic shock, and job satisfaction/re-enlistment relationships.

On the other hand, there are specific topical areas (e. g., manpower readiness forecasting, psychological adjustment to various duty assignments, occupational classification standards) in which inputs from the human resources and medical R&D communities should be integrated. In these areas, joint planning and coordination of effort is not only desirable but essential.

The system proposed by the Navy will effect coordination of work in these specific areas."

-- Air Force Response: We do not concur with the formation of such a group. The proposed planning mechanism violates the existing management process for R&D planning and programming. Specifically:

(1) The separate planning process for these Laboratories would subvert the total Air Force investment strategy process. This would, in essence, remove medical and human resources laboratory planning from effective control by the AFSC Director of Laboratories, with concomitant impact on the planning and budget cycles of other technology base programs.

(2) The single manager concept for all Air Force research, as instituted in AFOSR, would be subject to outside influences which could severely distort its efficiency.

(3) Continued efforts to achieve increased interdependencies using existing and proven management techniques are a better option than creating new planning groups and panels.

(4) The existing management overlay for these programs is at a minimum. In order to respond to the suggested array of planning panels, the Air Force would have to use senior managers from the laboratories. This investment in time and travel is not warranted by the conclusions of the study.

In summary, the Services disagree to the concept of coordinated planning of human resources and medical and life sciences. All oppose this concept at ODDR&E level as an encroachment upon the Service prerogatives for managing their programs.

-- DDR&E Recommendation and Action

Required: Joint Service planning should be done for defined, bounded, technical areas (e. g., in areas of human factors, the Memorandum of Understanding on human factors should be completed). This will be a continuing area of ODDR&E interest, but we will not play a direct role. Action: 1) The Navy take the lead in completing coordination of the memo of understanding for human factors by 19 November 1976. 2) Form a tri-Service ad hoc committee consisting of two representatives from each Service (one from Medicine and one from Human Resources) to identify other areas for tri-Service coordination and develop appropriate plans to be reported to ODDR&E by 2 May 1977. Report results of initial organizational meeting for this effort by 19 November 1976.

o LUS Recommendation: The Army, Navy and Air Force should acknowledge and actively pursue the concept of interdependency and participate in the follow-on effort to identify and agree to specific interdependency areas and lead Service responsibilities.

-- Army Response: "Interdependency is acknowledged as a viable concept whereby unwarranted duplication of technology base research is avoided through awareness of and reliance upon the efforts of another Service which may satisfy mutual needs in a specific area. Interdependency per se, however, does not imply the need for designating lead Services for associated areas. The proposed mechanism of coordinating the functions of program planning and execution through an ODDR&E/Joint Service Planning Group is viewed as an adequate and appropriate mechanism for achieving the desired goal."

-- Navy Response: "The Navy acknowledges and accepts the concept of interdependency as defined in the first sentence of Section 4.3, page 39, "Interdependency may be defined as the practice of avoiding unwarranted duplication of R&D by relying on another Service or Agency for part of the effort in a particular area of the Technology Base." There is an informal de facto form of interdependency which has proven to be quite effective. The Navy is not aware of any need for a formal effort to expand these areas of interdependency. The Navy feels the interdependency should be pursued through the existing mechanism of JMRC, TCP, and Tri-Service Panels. The Navy favors interdependency in the form of groups of knowledgeable scientists carefully examining a limited area to coordinate across Services.

The Navy does not agree with the concept of a lead Service as defined in Section 4.3, lines 16-19, page 39. The concept has many drawbacks, some of which are listed as follows:

(1) Imposes additional layers of administrative and technical management which interfere with orderly and timely programming and budgeting by the Navy and takes over decision-making authority of top naval management.

(2) Negates the Navy's R&D Planning, Management and Coordination System (OPNAVINST 5000.42A).

(3) Discourages new and unusual approaches to the solution of naval problems by people or activities outside the lead Service hierarchy, while encouraging the "not invented here (NIH) syndrome."

(4) Discourages the development and maintenance of a broad based, flexible, experienced and responsible naval medical and human resources research and development capability for the peacetime and wartime missions of the naval establishment.

(5) Tends to discourage funding investment by Services other than the lead Service."

-- Air Force Response: "There are considerable existing technology base areas for which the Air Force is completely dependent on the other Services, or civilian agencies. This is evidenced by the Medical and Biological Sciences TCP wherein the Air Force Biotechnology Program is almost completely contained in one chapter, Hazard Protection and Performance Effectiveness, of the six major program chapters in that document. As examples, the Air Force is totally dependent on other Service programs in battle care management, infectious diseases, food and nutrition, and mass casualty effects of nuclear weapons.

These are examples of interdependencies which have realized considerable resource cost avoidances in facilities and research programs. However, the proposed interdependency thrusts appear to change from these current macro arrangements to a work unit level planning comparison in selected technology areas where the Services have some commonality of interest. We fully support the concept and formalization of Service R&D interdependencies, but are concerned that the present interdependency thrusts are not following a logical path from general agreement to specific research efforts.

We are further concerned that the envisioned interdependencies across DoD medical and human resources programs do not fully address working interdependencies among these Laboratories and their associated physical science laboratories and product divisions.

The concept proposed in the draft report to have lead Service designations for almost all technology areas can only diminish the productivity of the programs that the report seeks to strengthen. The

rationale for this concept is not strongly made in the report; it is assumed to be a combination of forced tri-Service planning and avoidance of research duplication, which was not a finding of this study or the other review mechanisms now used. We seriously question the cost vs. benefit of across-the-board lead Service designations in technology base programs."

-- DDR&E Recommendation and Action

Required: Areas of interdependency should be selected on a case-by-case basis (e. g., Plan for Use of Computers in Training and Education with Air Force taking the lead). This area will remain an ODDR&E issue of interest. Action: 1) Air Force complete coordination on plan for Use of Computers by 19 November 1976. 2) Services use the above ad hoc committee to develop other interdependency agreements and RDT&E plans for implementation as part of the exercise above.

o LUS Recommendation: Designate the Army as lead Service for the conduct of all medical and human resources technology base work associated with the human aspects of helicopter operations. An R&D plan for this area should be developed by the Army to effectively coordinate the activities within the Army organizations, such as the Army Aeromedical Research Laboratory, ARI, and HEL, and among the Air Force and Navy. A focal point should be established with appropriate authority for reviewing, approving, and integrating proposed projects in this area. The Navy and Air Force should not engage independently in this area except by incorporation of their work in the Army master plan. It is recognized that the Navy and Air Force have expertise which can readily be applied to this problem area.

-- Army Response: "Concur in this recommendation. A great deal of tri-Service R&D and training is already being accomplished at Ft. Rucker."

-- Navy Response: "Agree with the Army having major responsibility for conducting medical technology base work relating to helicopter operations. However, Navy missions involving helicopters include some that are unique. These mission differences will impact on human factors engineering and training, including simulation. It is therefore preferred to coordinate the human resources work with the Army to ensure there is no duplication. The Navy does not agree with the requirement to obtain Army approval before conducting its own R&D in this area."

-- Air Force Response: Concur.

-- DDR&E Recommendation and Action Required: Implement concepts. Recognize special problems in human factors and training areas which must be resolved with issues of joint helio training and joint use simulator design and development for training. Action: Army lead in developing and coordinating a plan by 2 May 1977.

o LUS Recommendation: Authorize longer probationary periods for laboratory professionals. Employ professionals on term contracts with renewal options to be granted at the discretion of the laboratory director.

-- Army Response: No Comment.

-- Navy Response: "Concur, but with the proviso that a study be conducted prior to implementation to determine the implications of the proposal. While the recommendations are attractive to management, they may create such uncertainty among the staff as to bring on worse problems than they were intended to solve."

-- Air Force Response: "We agree with the concepts presented as offering greater management flexibility, and good for the laboratories. There are questions concerning their appropriateness in terms of federal statutes and regulations. These suggestions have wider application than the medical and human resources laboratories, or the DoD. It is suggested that they be reviewed by the appropriate OSD office."

-- DDR&E Recommendation and Action Required: Commission of Federal Laboratories (COFL) being asked to address this area on behalf of SR&T career fields. Action: DD(R&AT) meeting with COFL scheduled for October 1976.

o LUS Recommendation: Navy and Army establish review systems for overseas laboratories.

-- Service Position: Navy and Army concur. Navy will perform the reviews biannually; Army will also establish regular reassessment procedures on at least biannual basis.

-- DDR&E Recommendation and Action

Required: Accept Army and Navy response as long as biannual reviews are critical and objective. Will remain ODDR&E area of interest. Action: Army and Navy implementation plan by 19 November 1976.

- o LUS Recommendation: Establish a Joint Human Resources Research Conference with membership from each of the Military Departments, chaired by an outside consultant and with the Military Assistant for Human Resources, ODDR&E, as the Executive Secretary.

-- Army Response: Concur. This recommendation originally came from the Army Study.

-- Navy Response: Concur.

-- Air Force Response: "The commonly used terms human resources, human factors, and human engineering are used extensively in the draft report but there exists no commonly agreed to definition of these terms. The formation of a JHRC should be dependent on commonly agreed definitions of these terms in order to scope the JHRC in terms of TCP, program element, and functional organization breakouts. The existing Joint Medical Research Conference has, in recent times, shifted to management issues rather than a technical interchange forum, which, in essence, has created a series of monthly topical reviews. It is questionable that the Air Force investment in medical and human resources R&D warrants the extensive management process underway and envisioned by ODDR&E. It is recommended that ODDR&E draft charters for both the JMRC and JHRC so that the Services can come to common agreement on the content, intent, and degree of management oversight necessary to participate."

-- DDR&E Recommendation and Action

Required: Establish Joint Human Resources Conference, modeled after JMRC. Action: ODDR&E (E&LS) by 1 November 1976.

- o LUS Recommendation: The Navy should prepare a five-year plan for Naval aviation medicine and this plan should be coordinated with the Air Force which conducts the major program in this area. The plan should include a detailed review of the future of the NADC Crew Systems Department and the NAMRL Detachment at Michoud, Louisiana.

-- Navy Response: The Navy agreed to initiate a study in September 1976 with completion in January 1978.

-- DDR&E Recommendation and Action Required: Escalate the planning to inter-Service level; limit study to address all facilities in acceleration, vibration, impact areas. Air Force is asked to take lead in performing and coordinating the study; request study be completed by 1 June 1977.

5.2 Army Recommendations

o LUS Recommendation: The program of the Army Biomedical Laboratory, Aberdeen Proving Ground, should be "purified" to eliminate any work which is considered to be unacceptable to the Army Surgeon General for ethical reasons and the laboratory then reassigned from Army Materiel Command to the Army Medical R&D Command. The small amount of work eliminated from the Aberdeen program should be reassigned to the other development laboratories.

-- Army Response: "Non-concur in this recommendation. Action has already been taken to remove objectionable work from the BML program with the expectation that its future mission will be limited to Biomedical defense against chemical warfare. A revised agreement between The Surgeon General and the Commander, DARCOM, has been reached which clearly states what each of their responsibilities for the work of this laboratory will be. Therefore, there will be no change in assignment of this laboratory to the Medical R&D Command."

-- DDR&E Recommendation and Action Required: Keep the issue open since it is too early to evaluate the effectiveness of revised agreement. Re-examine this issue after a year of operation under the revised agreement.

o LUS Recommendation: A single organization with a clear charter to serve as central focal point in the Army for planning and executing human resources R&D and coupling its results to Army-wide problems (to include personnel, training concepts, and doctrine and materiel acquisition) should be established out of existing laboratories (HEL and ARI). This single organization should be assigned to the Army Materiel Command with Army staff responsibility placed within the DCSRDA.

-- Army Response: "This recommendation is unacceptable. The merger of ARI and HEL in the interests of providing the Army a focal point for common program planning and execution for human resources research is completely inappropriate. Both organizations have a long history and a separate identity readily recognized in the Army. The insignificant monetary savings which might be realized by such a merger are outweighed by the different missions of ARI and HEL in the systems life cycle development process. ARI's efforts focus on serving DCSPER's Army-wide mission of developing personnel concepts, doctrine, tactics and training individual soldiers for combat. HEL is responsible for the application of human engineering to Army materiel design, developing standards and specifications for direct use in hardware development for DARCOM. The Research Office, ODCSPER, HQDA, provides the appropriate integration of the ARI and HEL programs for Department of the Army. The present organizational alignment of ARI and HEL is most adequate, and this position is emphatically concurred in by DARCOM, DA DCSPER, and DA DCSRDA."

In follow-up discussions, ODDR&E (E&LS) recognized the Army non-concurrence but stated that there still remained a high potential for problems of overlap in the human factors area within the Army. Since ARI and HEL are predominately funded with RDT&E funds, it was felt that the ARI and HEL should be placed under R&D management in Army staff surveillance, and the Army should develop a central coordination structure for ARI, HEL, and PM TRADES. The recommendation for merger of ARI and HEL was withdrawn.

The Army position remained unchanged. The Army non-concurred; they perceive no problems with current management.

-- DDR&E Recommendation and Action

Required: Keep the issue open to further observe the effectiveness of the current program and management for one additional year.

o LUS Recommendation: There should be more Army Research Institute involvement in the material process.

-- Army Position: The Army report noted this as a problem. In later discussions, the Army stated that the problem had been solved during the past seven months.

-- DDR&E Recommendation and Action

Required: Keep the issue open to permit ODDR&E review of evidence that the problem has been solved. Documentation of ARI involvement in the material acquisition process should be sent to ODDR&E by 19 November 1976.

5.3 Navy Recommendations

o LUS Recommendation: The development and maturing of the newly created Naval Medical R&D Command (NMRDC) should be continued.

-- Navy Response: Concur

o LUS Recommendation: NMRDC should be required to participate in the selection of medical research contracts by the Office of Naval Research.

-- Navy Response: "For medical research contracts funded by NMRDC, the NMRDC is fully responsible for proposal selection, and works on a continuing basis with the ONR monitoring officer. The ONR funded contract research program (CRP) uses peer review groups including NMRDC representatives to review proposals for scientific merit. The majority of current CRP contracts name an NMRDC representative for coordination and beginning with FY 77 all medical research contracts will require coordination with NMRDC."

o LUS Recommendation: The Medical Field Research Laboratory, Camp Lejeune, should be converted from an R&D funded research facility to an O&M funded field medical unit, operationally funded but retaining the capability to host, on an "as-needed" basis, test and evaluation teams from other development laboratories. The small R&D program currently conducted at this laboratory should be transferred either to another Navy laboratory or to the Army's Natick Laboratories.

-- Navy Response: "A proposal to disestablish the Naval Medical Field Research Laboratory at Camp Lejeune, was forwarded to the Chief of Naval Operations on 16 March 1976. Selected R&D functions are to be transferred to other Navy laboratories with consequent increase in scientific productivity and responsiveness to operational requirements. The T&E functions of the laboratory will be accomplished by other Navy and Marine Corps activities, by the

Army Medical Bioengineering R&D Laboratory, the Army Research Institute of Environmental Medicine and through out-of-house contracts."

o LUS Recommendation: The Navy Toxicology Unit at Bethesda should be transferred and collocated with the Air Force program at the Aeromedical Research Laboratories, WPAFB.

-- Navy Response: "The Navy Toxicology Unit was integrated within the Naval Medical Research Institute since 1 May 1975. However, in view of the lack of long-term exposure facilities at NMRI and the increasing demand for data on chronic exposures to chemicals used by the Navy, a NMRI Toxicology Detachment is being established at the Aerospace Medical Research Laboratory, Wright-Patterson AFB. This Detachment will perform normobaric toxicological studies to develop dose-response relationships required for the establishment of permissible exposure limits. Research on hyperbaric and behavioral toxicology will continue to be conducted at NMRI."

o LUS Recommendation: Recommend that the Navy increase its emphasis in submarine medicine and in subsurface human factors R&D.

-- Navy Response: As requirements for additional research in submarine medicine and human factors are identified and validated, funding commensurate with the magnitude and priority of the work will be sought and programmed. Initial program efforts are being initiated in Fiscal 1977.

o LUS Recommendation: The Navy should develop NPRDC as the responsible agent for planning and coordinating the Navy's 6.2 and 6.3A efforts in human resources to include the human factors functions. It should be organizationally reassigned from the Bureau of Personnel to the Director of Navy Laboratories. The programs of the Human Factors Division of NELC, the Research Division of NTEC, and the selection and training work of NAMRL should be placed under the control of NPRDC to assess the value of these current programs and to plan an integrated follow-on effort with the work assigned to the appropriate facility for accomplishment. All Systems Command funded human resources 6.2 and 6.3A work should be coordinated with NPRDC. Plans should then be formulated to transition these programs to NPRDC for management.

-- Navy Response: "While agreeing with the goal of better coordination, the Navy must reject this specific proposal, for the following reasons:

(1) This proposal will set up a special, fenced area that is exempt from the normal Navy management structure and will thus create many administrative problems in terms of defining needs and requirements, and in POM and budget development.

(2) NPRDC was formed in 1973 out of three former personnel and training laboratories. Since that time, a significant part of the Center's effort has been occupied with becoming organized, establishing programs and obtaining key staff. In May 1975, it became a member of the Navy Material Command Laboratory System, consistent with ODDR&E recommendations, which in turn meant additional adjustment had to take place. NPRDC is not currently staffed to perform the recommended planning and management functions, nor is it suitably placed in the Navy organizational structure for this purpose.

(3) NPRDC's mission includes the coordination of Navy human resources R&D, and it is developing a capability to perform that part of its mission. The Navy proposal will take advantage of that capability.

The alternate proposal of the Navy is as follows:

(1) Since Navy Human Resources R&D is managed by the Chief of Naval Research for 6.1, the Chief of Naval Development for 6.2, and the Chief of Naval Operations for 6.3 and 6.4, there will be established a Navy Personnel and Training (new term to replace Human Resources) Steering Committee which will consist of professional representatives of the Chief of Naval Research, Chief of Naval Development, Director of Research, Development, Test and Evaluation (OP-098), and the Sponsors of personnel and training development.

(2) There will also be established a Navy Personnel and Training Advisory Committee. This Committee would be composed of representatives of the various performing organizations of the Navy Personnel and Training R&D Program, the Commandant of the Marine Corps, and the Naval Medical R&D Command.

This Committee would, under the guidance of the Steering Committee, review and develop appropriate inter-relationships among the managers and performing laboratories of the Navy program. It would also deal appropriately with those medical areas that are closely related to the Personnel and Training R&D program.

(3) In fulfilling its coordination function, NPRDC will collect and disseminate information concerning the program to sponsors, managers and performing organizations, conduct analyses and technological assessments, and recommend program modifications to the Advisory and Steering Committees. In this activity it would be tasked by the Steering Committee.

This arrangement will maintain the Navy's management structure and its sponsor relationships, and at the same time, meet the DDR&E interests in improved coordination.

There are several elements in this recommendation. Each will be discussed below.

With regard to NPRDC planning and coordinating the 6.2 and 6.3A work to include human factors:

(1) The Navy has assigned to NPRDC the mission of coordinating all Navy Personnel and Training R&D, including human factors.

(2) The Navy does not believe it appropriate at the present time for NPRDC to be the planning agent for this area of effort. It has proposed a procedure and a structure for planning the Navy's work in the preceding section.

The programs of the Human Factors Division of NELC, the Research and Technology Directorate of NTEC, and the selection and training work of NAMRL will be planned in a coordinated way through the Steering and Advisory Committees described previously, with NPRDC playing an important coordinating role.

Systems Command funded human resources 6.2 and 6.3 work will be coordinated with NPRDC, but the planning will be guided by the Steering and Advisory Committees.

NPRDC has been transferred to NAVMAT since the completion of the study.

The Navy proposes a planning and coordination organization that is consistent with the management structure that the Navy uses for all of its R&D."

-- DDR&E Recommendation and Action

Required: This alternative proposal by the Navy is acceptable. However, the effectiveness of this management arrangement will continue to be considered an item of special ODDR&E interest and subject to further discussion based upon results achieved.

o LUS Recommendation: NPRDC should participate with ONR in planning the 6.1 human resources program. NPRDC should consider the establishment of additional field units collocated with users, for example, in the area of flight training.

-- Navy Response: "NPRDC currently participates in planning the 6.1 human resources program, and provides comments on specific proposals of mutual interest when those proposals are received. Concur in having NPRDC consider the establishment of additional field units collocated with users."

o LUS Recommendation: The Naval Biomedical Research Laboratory, Berkeley, California, should be terminated as a Navy laboratory. Such a transition should not occur precipitously and should be accomplished in a manner that will cause the least disruption to the work underway. A transition planning group should be established which, in addition to its main objective of planning the transition of the laboratory to other sponsorship, will identify those specific work units in the area of infectious diseases that should be transferred to the Army Institute of Infectious Diseases at Fort Detrick, Maryland.

-- Navy Response: "The Navy does not plan to terminate NBL as a Navy laboratory. The Navy vitally requires a laboratory with a broad mission in basic and applied biosciences unrestrained by the mission and program responsibility of the CHBUMED. Such a laboratory addresses problems of a broad biological/ecological nature which fall outside of the purview of the BUMED laboratories. On 19 November 1975, the Navy changed the name of the Naval Biomedical Research Laboratory to the Naval Biosciences Laboratory (OPNAVNOTE 5450) with the mission to conduct research and development in biosciences related to the needs of the Naval Establishment. ONR Instruction 5450.5D stating the detailed mission and functions is in the final stages of preparation.

The revised mission and function for NBL will preclude redundancy in the R&D programs of NBL and the NMRDC laboratories.

In view of current DDR&E emphasis on increased contract versus in-house effort, the Navy does not wish to discontinue the unique NBL arrangement with the University of California in which the Navy provides specialized facilities and military personnel, and the University conducts the research."

-- DDR&E Recommendation and Action

Required: The Navy has prepared a plan to define the specific role of the laboratory in a new mission. The Navy mission statement and proposed work related to environmental issues is under review by ODDR&E. This issue will remain open until the review is completed. Feedback to the Navy is expected during the early part of CY 1977 with the view of resolving the issue during the FY 79 POM/PDM process.

5.4 Air Force Recommendations

o LUS Recommendation: AFR 80-51 should be revised to: (1) make RPRs part of the overall data base for technology planning by AFHRL, not the driving programmatic force; (2) provide DCS/P clear responsibilities in the generation and evaluation of requirements in personnel related RDT&E; (3) provide the DCS/P a clear role in the implementation of personnel related R&D products; (4) assign AFHRL the authority, subject to the review and approval of higher headquarters, to develop a Technology Base program based on RPRs and all other planning information, such as Technology Needs (TNs), PPGM, and laboratory plans; and (5) fund RPRs for analysis or other non-Technology Base efforts, on a cost reimbursable basis, with studies and analysis funds (6.5) or O&M funding.

-- Air Force Response: "The draft report comments extensively on the need to integrate personnel research requirements into the overall human resources technology base planning. The AFHRL currently expends resources against a prioritized list of RPRs. Some RPRs are perishable and must be accomplished on an immediate basis. AFHRL has the authority and direction to integrate the prioritized list of RPRs into the Technology Base program along with other planning information and requirements.

The responsibility of AF/DP in the generation of requirements is sufficiently clear and recognized. Action is underway to change AFR 80-51 in a manner which will clarify the roles of AF/DP, AFSC, and the user in implementation of products resulting from personnel related RDT&E."

-- DDR&E Recommendation and Action Required: The revised proposed draft revision was reviewed; the proposed revision is acceptable. ODDR&E should review final draft before publication.

5.5 Armed Forces Radiobiology Research Institute

AFRRI of the Defense Nuclear Agency is operated under the provisions of DoD Instruction 5105.33, which prescribes the Institute's responsibilities for conducting research in radiobiology and nuclear weapons effects. Additional responsibilities in the nuclear effects area were assigned to AFRRI by OJCS memorandum dated 15 May 1975, "Radiation Casualty Criteria for Land Battlefield Targets." During the past decade, the requirement for radiobiology and nuclear weapons effects research has diminished, and DNA's need for AFRRI is predicted to continue to diminish. Continuing to devote an increasing proportion of AFRRI's capacity to non-DoD work to compensate for the decrease in DNA support is not an acceptable strategy for an in-house DoD laboratory. As a result, the following alternatives are proposed:

(1) AFRRI be removed from assignment to the Defense Nuclear Agency and reassigned to the Uniformed Services University of the Health Sciences (USUHS) as a combined research and training facility.

(2) AFRRI be offered as a National Facility to an appropriate non-DoD agency, e.g., ERDA, for joint use by all Federal Agencies having a need or interest, e.g., ERDA, HEW, DoD, NSF, DOT, EPA.

(3) Close the laboratory.

o LUS Recommendation: Transfer of AFRRI to USUHS was the most attractive alternative to the study group, but the question should be examined in more detail. A follow-on working group should be established to determine the most productive future mission and organization placement for AFRRI.

-- DNA Response: "Do not concur with the final conclusion and proposed alternative for the disposition of AFRRRI. Strongly recommend that AFRRRI remain an integral subordinate unit of DNA, immediately responsive to the Service research requirements in accordance with the provisions of its present charter. Stated that:

(1) AFRRRI is now actively engaged in a long-range program of radiobiology research related combined combat stresses and collateral damage expected in theatre nuclear warfare;

(2) This program focus will be associated with a reduction of the reimbursable part of AFRRRI program;

(3) AFRRRI support of DNA's long-range requirements will require its continued subordination within and funding by DNA until the DoD Nuclear Weapon Effects requirements for research are fulfilled;

(4) The ultimate disposition of AFRRRI, once DNA requirements for Nuclear Weapons Effects are satisfied, as well as AFRRRI's relationship with the Uniformed Services University of the Health Sciences (USUHS) will be studied by the Board of Governors at an appropriate time; and

(5) This position has the concurrence of the Surgeons General and the President of USUHS."

-- Follow-Up Action: ODDR&E reviewed the DNA response and supporting documents (POM FY 1978-82, Minutes of the Medical NWED Long-Range Planning Meeting and the Minutes of the Twenty-Fourth Meeting of the AFRRRI Board of Governors) and conducted a special Joint Medical Research Conference (142nd JMRC, 21 June 1976) to review the DoD needs for further nuclear studies related to tactical nuclear weapons. ODDR&E concurs with the DNA position.

APPENDICES

- A. DDR&E Tasking Memo, 27 December 1974 and Management Objective
- B. Coordinating Board Membership
- C. Study Charter, 15 January 1975
- D. (1) Laboratories reviewed in PS&E LUS
(2) Laboratories reviewed in M&HR LUS
- E. Navy Funding Sources for M&HR Laboratories
 - (1) Medical
 - (2) Human Resources
- F. Army, Navy, and Air Force Study Membership
- G. Army Laboratory Consolidations
- H. Army Medical Laboratory Existing Specialization Listing and Proposed Lead Lab Assignments
- I. Candidate Interdependency Area
- J. Total M&HR Lab Manpower (FY 71-74)
- K. Medical and Human Resources Technology Base Planning Group (Proposed)
- L. Army Response
- M. Navy Response
- N. Air Force Response
- O. Defense Nuclear Agency Response
- P. DDR&E Memo to Assistant Secretary of the Army (R&D), 27 September 1976
- Q. DDR&E Memo to Assistant Secretary of the Navy (R&D), 27 September 1976
- R. DDR&E Memo to Assistant Secretary of the Air Force (R&D) 27 September 1976



DIRECTOR OF DEFENSE RESEARCH AND ENGINEERING
WASHINGTON, D. C. 20301

71

27 DEC 1974

APPENDIX A

MEMORANDUM FOR THE ASSISTANT SECRETARIES OF THE
MILITARY DEPARTMENTS (R&D)

SUBJECT: Medical and Human Resources Laboratories
Utilization Study

By memorandum of 28 February 1974 I announced the initiation of a Laboratory Utilization Study for the purpose of re-examining our strategy for in-house laboratory utilization. In order to restrict the study to a reasonable scope, I explicitly excluded the medical and human resources laboratories. The Laboratory Utilization Study is now coming to a conclusion with recommendations for action and plans for implementation being prepared for review by the Secretary of Defense.

It is now time for us to turn our attention to the laboratories that were excluded from the original effort. Accordingly, I am initiating a medical and human resources laboratories utilization study which will have similar objectives to the original study but the mechanics of which may be modified to better suit the subject matter of these technical areas. I have tasked Colonel John J. McCambridge, Acting Assistant Director (Environmental and Life Sciences), to chair this study under the general cognizance of the Deputy Director (Research and Advanced Technology).

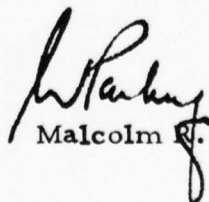
Malcolm G. Currie

Objective:

Action: Extend the DoD Laboratory Utilization Study to include medical and human resources laboratories. Identify excess capacity, overlapping capability, shortfalls, and instances where R&D could be contracted to industry at a savings. Plan of action by 1 September 1975.

Synopsis: The DoD Laboratory Utilization Study which was initiated by DDR&E memorandum of 28 February addressed the above considerations for DoD "hardware" laboratories only. The medical and human resources laboratories were specifically excluded from the purview of the study. The Laboratory Utilization Study is now almost complete with a plan of action for implementation of its recommendations scheduled for completion in January 1975. The study envisioned by this objective will extend the Laboratory Utilization Study to include the medical and human resources laboratories as a Phase II effort.

<u>Milestone Schedule</u>	<u>Target Date</u>	<u>Date Completed</u>	<u>Remarks</u>
Initiate the study	15 January 1975	15 January 1975	
Service committees organized and chartered	24 January 1975	1 February 1975	
Working group studies initiated	1 February 1975	1 February 1975	
Working Group studies completed	31 March 1975	31 March 1975	except the Nav (rec'd 21 May)
Coordinating Board review and rework of working group output	30 April 1975	30 May 1975	
Draft report to R&E Policy Council	15 June 1975	22 September 1975	
Plan of action	1 September 1975		
Initiate implementation			

Dr. John L. Allen
DD(R&AT), x55036

APPENDIX A

OSD/ TRI-SERVICE COORDINATING BOARD

Colonel John J. McCambridge, Acting Assistant Director (Environmental & Life Sciences),
ODDR&E, Chairman

Colonel, S. C. White, ODDR&E (Medical)

LtCol. Henry L. Taylor, ODDR&E (Human Resources)

Colonel R. Barquist, Army (Medical)

Colonel R. Viterna, Army (Human Resources)

Dr. J. Schmidt, Navy (Medical)

Dr. H. Seymour, Navy (Human Resources)

Colonel R. McIver, Air Force (Medical)

Colonel O. Berthold, Air Force (Human Resources)



January 15, 1975

MEMORANDUM FOR DISTRIBUTION

SUBJECT: Medical and Human Resources Laboratories Utilization
Study Charter

Reference: DDR&E Memorandum to the Assistant Secretaries (R&D),
27 December 1974, attached

By the referenced memorandum DDR&E directed the conduct of a study on the utilization of in-house medical and human resources laboratories. The purpose of this memorandum is to set forth the objectives, scope and schedule of such a study. The manner in which the actual studies by the three Services are to be conducted will be determined in subsequent meetings by a Coordinating Board consisting of the following:

For DDR&E	Col. John J. McCambridge, Chairman
For the Army	Col. Richard Barquist, Col. Robert O. Viterna
For the Navy	Dr. Jack R. Schmidt, Dr. Harry Seymour
For the Air Force	Col. R. E. McIver, Col. Oscar Berthold

I. Study Objective

The purpose of this investigation is to:

- 1) examine alternative ways by which each Service might structure, organize and utilize its in-house medical and human resources laboratories and the management structures above the laboratories and to identify the recommended management structure for these laboratories.
- 2) seek out and explore the potential benefits to each Service of the use of other Service laboratories or multi-Service use of its own laboratories, where potentially appropriate.



74

- 3) recommend restructuring/reorganizing and changes to existing laws, policies and directives whenever a significant enhancement of the RDT&E process is deemed likely via such changes.
- 4) review the requirements for, and utilization of, major and unique research facilities with a view toward reducing the costs associated with them, and
- 5) identify those steps necessary to accomplish the changes recommended.

The overall goal of this examination is that of maximizing the effectiveness of the medical and human resources laboratories' contribution to the RDT&E process and to military operational effectiveness in the face of

- 1) probable continued budget constriction
- 2) possible directed reductions in laboratory manpower, and
- 3) realities of Civil Service and military personnel restrictions.

The effectiveness of the laboratory system is to be measured by its overall contribution to the long term enhancement of military capability. Consideration is to be given to subsidiary measures of performance (e. g., maximizing the production of new technology and new knowledge) but any conflicting factors are to be resolved with a focus on this enhancement.

II. Scope of the Study

For the purposes of this study, the term "in-house laboratory" will be understood to include all DoD-operated facilities performing medical or human resources R&D. In recognition of their similarities in function, potential for overlap and possible complementary interaction with the in-house laboratories, the study should also include facilities having a significant program of clinical research funded from other appropriations.

Specific areas for inquiry should include but need not be limited to the following (each item is to be addressed in the context of each of the Services' major functional needs and required supporting technological areas):

A. Military R&D Organizational Structure

1. missions/number/size of laboratories
2. lead laboratory assignments
3. stimulation and control of competition
4. possibilities for multi-Service use of facilities
5. size and structure of Service laboratory management/
laboratory supervisory organization
6. in order to stimulate a "fresh approach", each Service will specifically consider the impact of (a) 10% and (b) 20% reductions in total manpower (from authorized end strength FY 74) in the laboratories in question, and will identify how such reductions would be apportioned (associated funds to remain available for contract work).

B. Laboratory Involvement

1. degree and type of involvement in systems acquisition (e. g. , systems studies, requirements definition, RFP preparation, contractor selection and monitoring, in-house development, in-house production, etc.) and manpower management.
2. degree and type of in-house laboratory involvement in tech base (e. g. , in-house involvement, contractual efforts, choice of technical areas to support systems acquisition, operations, and manpower management).
3. degree of involvement in support of existing weapons systems, military operations and the active duty force.
4. degree of support to other Service needs (e. g. , technical inputs for planning, budgeting and decision processes, procedure, doctrine, quick policy changes and response to field needs).

C. Laboratory Program Generation and Control

1. responsibility for and methodology of program structuring (to include externally generated requirements)
 - a. systems acquisition program
 - b. tech base program

2. Service program review and approval procedure
3. DDR&E program review and approval procedure
4. method of funding
 - a. systems acquisition program
 - b. tech base program
 - c. facility costs
 - d. support to operational forces
5. method of alteration of program during execution and approval process therefor.
6. method of and procedure for appraisal of laboratory performance
7. use of outside technical expertise to evaluate program quality

D. Quality of Laboratories

1. attraction of good Lab Directors/Technical Directors and other senior people
2. attraction and retention of good technologists

III. Study Supervision

All Services' study activities will be monitored by the Coordinating Board described above.

IV. Study Output

The output of the study is to be in the form of written reports to ODD(R&AT) by each of the three Services giving its findings, conclusions and recommended actions with regard to each of the areas for inquiry given in Section II. Each recommendation is to be accompanied by a statement outlining steps by which the implementation can be carried out and a listing of the anticipated problems of each implementing recommendation (impact upon programs, facilities and people, as well as

financial impacts). The report should also contain a listing of the recommendations in the order of the cost/benefit ratio anticipated from implementing each recommendation (i. e., those recommendations that combine the features of relative ease of implementation and substantial expected payoff should be high on the list; those that will either be very difficult to implement and/or relatively low in payoff, near the bottom). It is recognized that the ordering may have to be largely subjective.

The recommended course of action should incorporate a proposal for a periodic review of the progress, benefits and costs accruing as a result of the study.

V. Schedule

1. Service committees organized and chartered - 17 January
2. Working group studies - 17 January - 17 March
3. Coordinating Board review and rework of working group output - 17 March - 11 April
4. Report for coordination - 21 April
5. Coordinated report to R&E Policy Council - 31 May

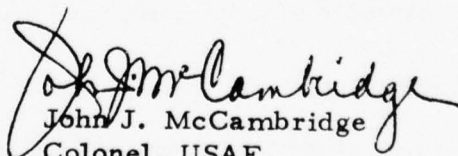

John J. McCambridge
Colonel, USAF
Acting Assistant Director
(Environmental & Life Sciences)

DISTRIBUTIONArmy

Dr. Emerson
 DCS/RDA
 Surgeon General Army
 BGEN Dirks
 Col. Barquist
 Dr. Lasser
 Col. Viterna
 Mr. Klein

Navy

Dr. Koslov
 OP-098
 Chief, Bureau of Med & Surgery
 Capt. Brodine
 Dr. Schmidt
 Dr. Seymour
 Capt. Austin, BuMed
 Mr. Probus

Air Force

Dr. Beam
 AFRD
 Surgeon General, Air Force
 AFRDPS
 MGEN Tkash
 Col. McIver
 Col. Berthold
 BGEN Hendricks
 Col. D. Carter, AFSGPR

DNA

Mr. Haas
 Capt. Varon, AFRR1

OSD

DDR&E
 Prin Dep
 Mr. Fryklund
 ASD(M&RA)

OSD (Cont.)

ASD(H&E)
 OASD(LA), Mr. Seymour
 Col. E. Huycke, OASD(H&E)
 Dr. Allen
 Col. White
 Lt. Col. Taylor

ARMY R&D LABORATORIES INCLUDED IN LUS
FY 1974 END STRENGTH

	<u>Military</u>	<u>Civilian</u>
Air Mobility R&D Laboratory	40	598
Atmospheric Sciences Laboratory	440	281
Avionics Laboratory	13	248
Ballistics Research Laboratories	66	817
Benet Weapons Laboratory	7	390
Civil Engineering Research Laboratory	5	303
Cold Region Research and Engineering Laboratory	42	244
Combat Surveillance and Target Acquisition Laboratories	23	320
Communications ADP Laboratory	12	394
Edgewood Arsenal Laboratories	173	898
Electronic Warfare Laboratory	50	417
Electronics Technology and Devices Laboratory	5	368
Engineer Topographic Laboratory	20	310
Frankford Arsenal Laboratories	28	1648
Harry Diamond Laboratories	9	1578
Materials and Mechanics Research Center	9	597
Missile Research, Development and Engineering Laboratory	40	1219
Mobility Equipment R&D Center	68	1578
Natick Laboratories	126	1183
Night Vision Laboratory	51	396
Picatinny Arsenal Laboratories	54	2865
Rock Island Arsenal Laboratories	16	764
Tank-Automotive Laboratories	<u>34</u>	<u>905</u>
	1331	18,321

APPENDIX D (1)

NAVY R&D LABORATORIES INCLUDED IN LUS
FY 1974 END STRENGTH

	<u>Military</u>	<u>Civilian</u>
Environmental Prediction Research Facility	15	34
Naval Air Development Center	339	2489
Naval Civil Engineering Laboratory	16	301
Naval Coastal Systems Laboratory	102	618
Naval Electronics Laboratory Center	90	1492
Naval Ordnance Laboratory	40	2791
Naval Research Laboratory	119	4008
Naval Ship Research and Development Center	-68	2905
Naval Undersea Center	264	1656
Naval Underwater Systems Center	148	3238
Naval Weapons Center	588	4655
Naval Weapons Laboratory	<u>89</u>	<u>2802</u>
	1878	26989

AIR FORCE R&D LABORATORIES INCLUDED IN LUS
FY 1974 END STRENGTH

	<u>Military</u>	<u>Civilian</u>
Aeropropulsion Laboratory	49	350
Aerospace Research Laboratories	69	174
Armaments Technology Laboratory	233	543
Avionics Laboratory	195	880
Cambridge Research Laboratory	157	904
Flight Dynamics Laboratory	207	995
Frank J. Seiler Research Laboratory	22	9
Materials Laboratory	56	333
Rocket Propulsion Laboratory	178	267
Rome Air Development Center	308	1155
Weapons Laboratory	<u>735</u>	<u>403</u>
	2209	6013

	<u>Military</u>	<u>Civilian</u>
Army	1331	18321
Navy	1878	26989
Air Force	<u>2209</u>	<u>6013</u>
Grand Totals	5418	51323

Total 56741

LABORATORIES REVIEWED IN MEDICAL AND HUMAN RESOURCES
LABORATORY UTILIZATION STUDY

ARMY

Walter Reed Army Institute of Research
U. S. Army Institute of Dental Research
U. S. Army Bioengineering Research and Development
Laboratory
U. S. Army Biomedical Laboratory
U. S. Army Medical Research Institute of Infectious Diseases
U. S. Army Institute of Surgical Research
U. S. Army Research Institute of Environmental Medicine
U. S. Army Aeromedical Research Laboratory
Letterman Army Institute of Research
Army Research Institute for the Behavioral & Social Sciences
U. S. Army Human Engineering Laboratory
U. S. Army Training Devices Agency
Natick Research and Development Command

NAVY

Naval Aeromedical Research Laboratory
Naval Biomedical Research Laboratory
Naval Blood Research Laboratory
Naval Dental Research Institute
Submarine Medical Research Laboratory
Medical Field Research Laboratory
Naval Medical Research Institute
NAMRU-2, Taiwan
NAMRU-3, Egypt
NAMRU-5, Ethiopia
Toxicology Unit, National Naval Medical Center
Naval Health Research Center
NADC (Crew Systems Department), Warminster, Pa.

AIR FORCE

Aerospace Medical Research Laboratory
USAF School of Aerospace Medicine
Air Force Human Resources Laboratory

DNA

Armed Forces Radiobiology Research Institute

MEDICAL RESEARCH & DEVELOPMENT FUNDING PROFILE

NAVY FY75

APPENDIX E (1)

<u>PROGRAM ELEMENT</u>	<u>\$(K)</u>
61152N In-House Independent Laboratory Research	560
61153N Defense Research Sciences (Biomedical)	8,844
62758N Biomedical Technology	7,499
62765N Energy & Environmental Protection Technology	410
63706N Advanced Medical Development	5,145
63713N Ocean Engineering Technology Development (Biomedical)	3,160
64771N Medical Development (Engineering)	526
65861N RDT&E Laboratory & Facilities Management & Support	2,229
65862N RDT&E Instrumentation & Material Support	1,268
	<hr/>
TOTAL	29,641*

* Included in above profile of FY 75 funds are the following major elements other than the Naval Medical Research & Development Command.

ONR 61153N	4,744K
62758N	50K
NAVAIR 62758N	644K
NAVSUP 62758N	467K
Subtotal	<hr/> 5,905K

HUMAN RESOURCES FUNDING PROFILE

PROGRAM ELEMENT	\$K	FY 75
61152N		
In-House Laboratory Independent Research		103
	RESEARCH	131
61153N		
Behavioral and Social Sciences		3080
62763N		
Human Resources	EXPLORATORY DEVELOPMENT	7675
63707N		
Manpower Management Effectiveness (P43-07)		1753
Human Factors Engineering Technology (W43-13)		1109
63720N		
Education & Training Development (P43-03)	ADVANCED DEVELOPMENT	2775
Operational Decision Aids (43-03)		810
Training Device Technology (W43-08)		2835
N64703N		
Training Devices Development Prototype	ENGINEERING DEVELOPMENT	8950
	TOTAL	29221

AIR FORCE STUDY GROUP MEMBERSHIP

MG George E. Schafer (Chairman) Commander, Aerospace Medical Division	Colonel John F. Lisella Assistant DCS/Development Plans
Colonel Harold E. Fischer (Co-Chairman) Commander, Air Force Human Resources Laboratory	Colonel Winfield S. Harpe Assistant for Personnel, Plans, Programs and Organizational Requirements
Dr. Billy E. Welch Special Assistant for Environmental Quality Office of the Secretary of the Air Force	<u>Liaison Officers</u>
Mr. Peter Murray USAF Retired Formerly Director of Laboratories, AFSC	Colonel Francis C. Cadigan, Jr. Chief, Medical Research Directorate USAMRDC
Dr. Douwe B. Yntema Harvard, Senior Research Associate in Psychology	Colonel William C. Maus Executive Officer, U.S. Army Research Institute
Dr. Lysle Peterson Chairman, Aerospace Biomedical Panel, SAB	Mr. Elmer Hutchins Management Analyst, Navy Personnel R&D Command
Colonel Neville P. Clarke Director, Research and Development Directorate	
Colonel Harold B. Powell Director of Operations, AFHRL	
Colonel Loren A. Anderson Director of Crew and AGE Engineering	
Colonel Donald I. Carter Assistant for Medical Research & Standardization, AFSG	

AD-A039 560

OFFICE OF THE DIRECTOR OF DEFENSE RESEARCH AND ENGINE--ETC F/G 5/1
THE DOD MEDICAL AND HUMAN RESOURCES LABORATORIES UTILIZATION ST--ETC(U)
SEP 76

UNCLASSIFIED

NL

2 of 2
ADA039 560

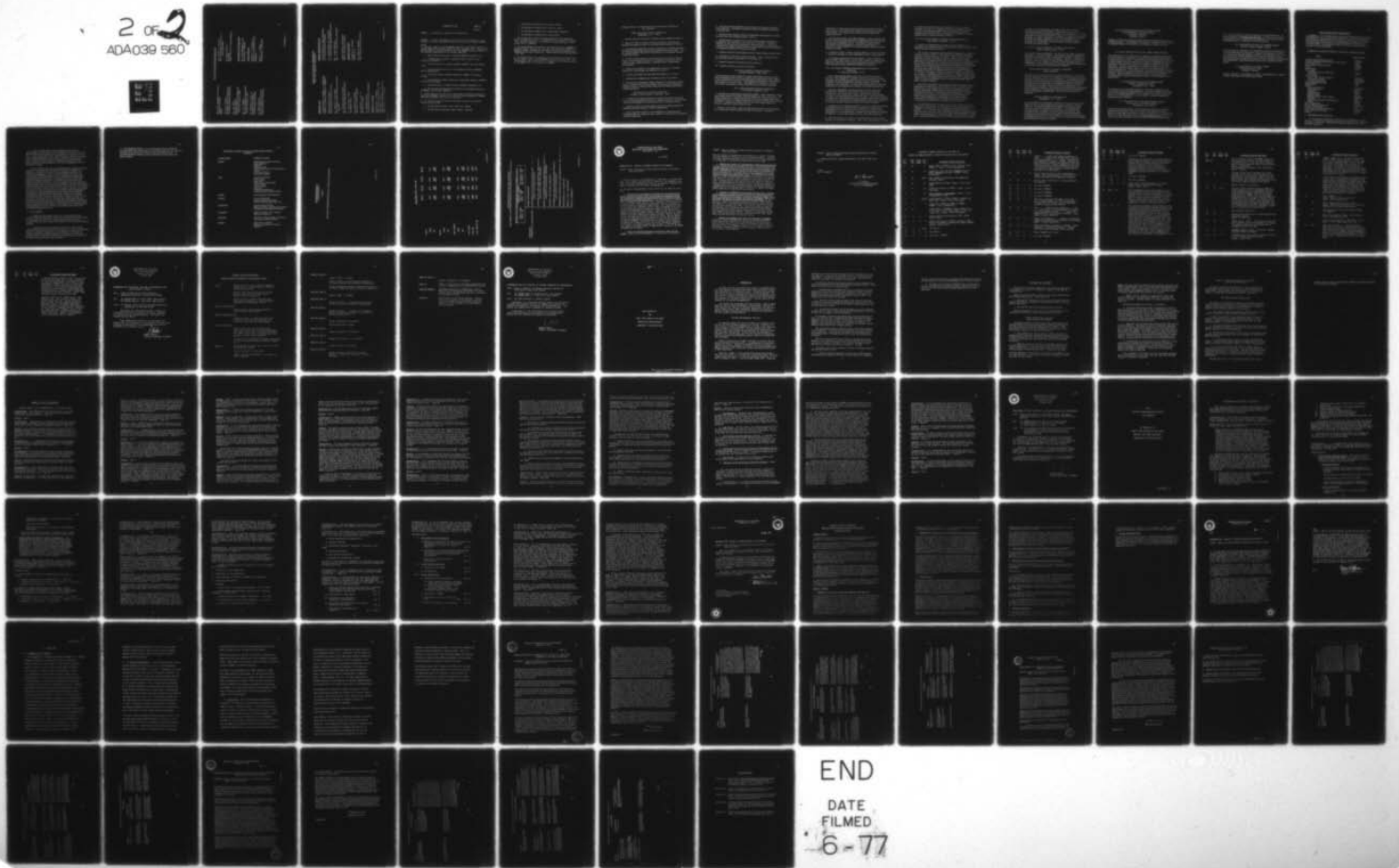

END

DATE
FILMED

6-77

2

OF



ADA039 560

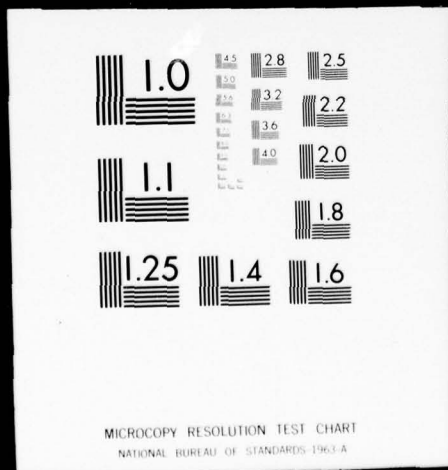

NAVY STUDY GROUP MEMBERSHIP

Mr. Bruno Augenstein (Chairman)
Resident Consultant
RAND

Dr. E. P. Cronkite
Chairman, Medical Department
Brookhaven National Laboratory

Dr. J. R. Seal
Scientific Director
National Institute of Allergy and
Infectious Diseases (NIH)

Dr. J. P. Pollard
Director, Biological and Medical
Sciences Division, ONR

Dr. Nicholas A. Bond, Jr.
Professor of Psychology
California State University

Dr. Paul Tamarkin
Director, Physical Sciences
General Research Corporation

Cdr. Stephen J. McArdle
Special Assistant to the Chief of
Naval Personnel

Dr. Robert Mackie
President
Human Factors Research Institute

Consultant to the Committee

Dr. David Steinhardt, M. D.
Santa Clara, California

Liaison Officers

Colonel F. C. Cadigan, Jr.
Director of Medical Research
USAMRDC

Major T. L. Kingery
Headquarters, AFSC/SGB

ARMY STUDY GROUP MEMBERSHIP
(Dr. K. C. Emerson, Chairman)

MEDICAL LUS

Colonel Francis C. Cadigan, Jr. (Chairman)
Director of Medical Research, USAMRDC

Colonel Hollis E. Bivens
Chief, Surgical Research Division

Lt. Colonel N. Bruce Chase
Chief, Environmental Protection Research
Division

Lt. Colonel Charles M. Dettor
Medical Toxicology Research Officer

Lt. Colonel Hal F. Stolz
Veterinary Corps

Mr. Robert H. Estensen
Operations Research Analyst

Dr. Herbert L. Ley, Jr.
Medical Consultant

Dr. Marshall Guthrie
Civilian Medical Research Manager

LIAISON OFFICERS

Colonel Laird F. Schaller
Chief of Aerospace Medicine, AFSC
Cdr. Paul D. Nelson
Head, Human Performance Division
Naval Medical R&D Command

HUMAN RESOURCES LUS

Colonel William C. Maus (Chairman)
U. S. Army Research Institute

Lt. Colonel Richard D. Kavanaugh
U. S. Army Human Engineering Laboratory

Mr. Joseph Lindwarm
Hqs., U. S. Army Materiel Command

Captain James E. McCarroll
Office, The Surgeon General

LIAISON OFFICERS

Colonel O. A. Berthold
AFHRL (CV)

Dr. Harry R. Seymour
Naval Personnel R&D Command

INFORMATION PAPER

2 APR 1974

SGRD-SSO

SUBJECT: Consolidation of Laboratories and Functions

PURPOSE. To provide information on the consolidation of laboratories and functions in the US Army Medical Research and Development Command (USAMRDC)

FACTS.

1. The basic authority for the USAMRDC laboratory consolidation efforts is Program Change Decision (PCD) Number A-7-020, 7 November 1967. Consolidation has proceeded in accordance with the PCD. The USAMRDC currently consists of the following laboratories at the location specified:

- a. Walter Reed Army Institute of Research (WRAIR), Washington, DC.
 - b. Letterman Army Institute of Research (LAIR), Presidio of San Francisco, California.
 - c. US Army Institute of Surgical Research (USAISR), Fort Sam Houston, Texas.
 - d. US Army Research Institute of Environmental Medicine (USARIEM), Natick, Massachusetts.
 - e. US Army Aeromedical Research Laboratory (USAARL), Fort Rucker, Alabama.
 - f. US Army Medical Research Institute of Infectious Diseases (USARIID), Fort Detrick, Maryland.
 - g. US Army Institute of Dental Research (USAIDR), Washington, DC.
 - h. US Army Medical Bioengineering Research and Development Laboratory (USAMBRDL), Fort Detrick, Maryland.
2. Consolidation of the LAIR, the US Army Medical Research and Nutrition Laboratory (USAMRNL), and the US Army Medical Research Laboratory (USAMRL) into the new LAIR was completed on 1 July 1974.
3. All overseas research activities have been assigned to the Special Foreign Activity WRAIR.
- a. US Army Medical Research Unit, Canal Zone, Panama.
 - b. US Army Medical Component, SEATO, Bangkok, Thailand.

- c. US Army Medical Research Unit, Nairobi, Kenya.
 - d. US Army Medical Research Unit, Brasilia, Brazil.
 - e. US Army Medical Research Unit, Kuala Lumpur, Malaysia.
 - f. US Army Medical Research Unit, Belem, Brazil.
4. The US Army Arctic Medical Research Laboratory, Fort Wainwright, Alaska, a subordinate unit of the USARIEM was discontinued on 5 January 1976. Special projects in cold research are being conducted as field studies from the USARIEM.
5. The US Army Medical Environmental and Engineering Unit (USAMEERU) at Edgewood Arsenal, Maryland, and the Joint Laser Safety Team (JLST) at Frankford Arsenal, Pennsylvania have been relocated and assigned to the USAMBRDL and the LAIR respectively. These relocations were accomplished 1 July 1974.
6. The Surgeon General has approved the discontinuation of the US Army Medical Research Unit - Panama (USAMRU-P) effective 30 June 1976. The continuation of the tissue culture and animal model work being conducted at the USAMRU-P will be continued at the WRAIR.

**Listing of Major or Unique Research & Development Capabilities
by Laboratory**

**Walter Reed Army Institute of Research
Washington, D. C. 20012**

1. **On-site research in tropical medicine at six overseas laboratories.**
2. **Major DoD base in tropical medicine research, encompassing specific disciplines in areas of communicable and infectious diseases.**
3. **In-house and extramural research programs on chemotherapeutics and chemoprophylactics against drug resistant forms of malaria. This is a unique program that covers the spectrum from synthesis through human field trials.**
4. **In-house and extramural research programs in drug and alcohol abuse; and development of drugs or vaccines that will protect the US soldier against trypanosomiasis, schistosomiasis, leishmaniasis, and filariasis.**
5. **Clustered disciplines in neuropsychiatric sciences, to include behavioral, epidemiologic and psychiatric research.**
6. **Limited capabilities for pilot plant development of vaccines.**
7. **Extensive and sophisticated microwave research facilities.**
8. **The Division of Biological Sensor Research is providing the Army with an improved detector dog capable of tracing; detecting ambush, tunnels, weapons, mine and body traps; and of locating casualties in combat operations.**

**Letterman Army Institute of Research
Presidio of San Francisco, California 94129**

1. **To determine nutritional status of troops in all environments and to recommend nutritional measures in support of optimum performance. This is accomplished for all Services by use of nutrition surveys.**
2. **Conducts research in food hygiene and recommends standards for wholesomeness and safety in military subsistence.**
3. **Insect repellent research is accomplished in conjunction with dermatologists who assess the skin irritation caused by and acceptability of insect repellents.**

4. Provides beds and metabolic ward facilities for studies in nutrition and metabolism. Operates a metabolic research kitchen for preparation of special diets.
5. Evaluates and conducts research to determine the hazards to the skin and eyes from non-ionizing radiation sources.
6. Dermatological research is directed to epidemiology, pathogenesis, prophylaxis, and treatment of skin disorders in the field. Conducts research on prevention and treatment of friction blisters. Can provide a team that is capable of going anywhere in the world to assist Commanders in solving skin problems of troops in the field.
7. Conducts research on prolonging effective liquid storage of whole blood.
8. Capability to breed and condition primates. This is a growing asset since several species of primates are becoming rare.
9. Conducts research on traumatic injury of the eye.
10. Conducts research on shock and trauma.

U. S. Army Institute of Surgical Research
Fort Sam Houston, Texas 78234

Multi-disciplinary staff caring for a large concentration of burn patients and performing parallel research studies in this specialized area. Significant contributions to the care of burn injured patients have resulted from this research over many years. The Institute is consulted on a world-wide basis concerning its research and the care given these casualties.

U. S. Army Aeromedical Research Laboratory
Fort Rucker, Alabama 36360

1. Helicopter In-Flight Monitoring System (HIMS): Unique system to collect and transmit flight profile data reflecting inflight aircrew performance. The system enables very careful assessment of the effect of physiological and pathological factors on inflight performance as well as determining precisely the effect of variations in flight profile on the psychophysiological and physical workloads imposed upon aircrew.
2. Helmet Test Facility: Unique facility to test all aspects of mechanical force attenuation characteristics of protective helmets. It includes

capabilities for destructive and non-destructive testing for impact acceleration, buffet acceleration, effects of temperature variation, POL exposure, and aging of both helmet shell and suspension/retention systems.

3. **Real Ear Attenuation Test (REAT) System:** Unique capability for objective testing of sound attenuation capabilities of muff and helmet type acoustic protective devices. This system utilizes special microphones and ADP equipment to provide objective data in a fraction of the time required for the less accurate industry-standard subjective method.

4. **Vibration Facility:** Unique vibration platform to study the effects of helicopter vibration on musculoskeletal and other target systems.

5. **Life Support Equipment Retrieval System:** Unique capability to study in detail failure modes and life cycle changes in protective and supportive capability of life support equipment returned from the field following aircraft mishaps involving such equipment.

**U.S. Army Medical Bioengineering Research & Development
Laboratory
Ft. Detrick, Maryland 21701**

1. The comprehensive engineering resources of this laboratory provide a unique capability to develop field medical equipment from the initial concept study through the final procurement package. This capability includes all aspects of prototype design, fabrication, evaluation, and refinement. No other Army laboratory has a similar capability for the development of military field medical equipment.

2. Although USAMBRDL's physical facilities for bio-materials research are common to most advanced bio-medical research laboratories, they do provide a major capability for the synthesis, evaluation, and refinement of new bio-materials. This lab has played a leading role in the development of bio-medical applications of polymer technology and in studies of the biodegradability of bio-materials such as artificial tendons, sutures, and burn and wound dressings.

3. Designated as The Surgeon General's arm for environmental health engineering research, this lab has the capability to conduct basic investigations in such diverse areas as chemical reaction kinetics, identification of trace substances, qualitative and quantitative analyses for bacteria, and pilot plan studies of water and waste treatment.

4. The combination of the major capabilities listed above gives this lab one more significant capability. With a staff comprising more than

30 professional disciplines and the extensive technical support facilities of the lab, it is capable of very rapid response to urgent one-time requirements ranging from the production of limited quantities of materiel not yet in the procurement system to solving urgent uniquely military pollution problems.

U.S. Army Medical Research Institute of Infectious Diseases
Fort Detrick, Maryland 21701

1. Complex and sophisticated program of medical research is conducted in two large buildings, which provide a total of approximately 300,000 square feet of floor space.
2. The recently constructed main building (Building 1425) contains 23 modern laboratory suites, which represent the latest in functional concepts, laboratory design, and safety. Safety features built into these laboratories, which permit studies with the most virulent pathogenic and dreaded diseases with minimal threat to research workers and complete safety for the surrounding community, are as follows: Sealed microbiological safety cabinet systems operated under negative pressure with access through air locks and ultraviolet barriers; personnel safety suits equipped with individualized conditioned air; autoclaves; the ability to establish differential negative air balances in response to the degree of hazard within the building; filtration and incineration of building exhaust air; and special clothing change rooms. These complex and sophisticated laboratories provide a nearly unique resource among laboratories in the free world for the safe study of highly contagious diseases.
3. This facility includes a 20-bed general medical treatment ward, an outpatient treatment clinic, and a 16-bed research ward that can be isolated into a self-contained environment for volunteer studies. Special capabilities include electron microscopy and electron spin resonance laboratory, a radioimmunoassay laboratory, a vaccine production suite suitable for preparing vaccines for human use, freeze-drying equipment, and equipment for isotope studies. Laboratories and equipment for radiation studies in acute and chronically infected laboratory animals are also provided.
4. The USAMRIID Annex (Building 1412) contains equipment for the quantitative administration of vaccines and/or microorganisms by the respiratory route to man, other primates, and small laboratory animals. Two 6,200 liter environmentally controlled aerosol chambers represent the primary facilities, with connecting hood systems to hold safely 2,500 guinea pigs in individual cages or 250 primates or 25,000 mice. Supporting laboratory suites are being modernized and updated

to conform to the operational and safety standards of excellence found throughout the new building. Other annex space has been converted into (a) a physiology laboratory where temperature, humidity and noise levels can be controlled for study of the effects of infectious diseases on cardiac, respiratory, and other physiological functions; (b) additional holding facilities; and (c) microbiology, virology, serology, and immunology research laboratories with supporting services and animal rooms.

U. S. Army Research Institute of Environmental Medicine
Natick, Massachusetts 01760

Cold region research capability at US Army Arctic Medical Research Laboratory, Fairbanks, Alaska. High altitude research capability at Pikes Peak Research Facility, Pikes Peak, Colorado. A hypobaric chamber, man-rated at 40,000 feet altitude, capable of housing twelve subjects at US Army Research Institute of Environmental Medicine (USARIEM), Natick, Massachusetts, plus large and small temperature and humidity controlled chambers also at USARIEM.

Arctic Medical Research Laboratory (USARIEM)
Alaska (AMRLA)

The AMRLA is the only US military medical laboratory in the Arctic with the equipment, facilities and staffing for research on the medical problems of the soldier in a cold environment. The Alaskan laboratory provides the only environment for practical biomedical evaluation of equipment in field maneuvers, the physiological effects of prolonged cold exposure, and energy cost to the soldier of performing cold weather field operations. The laboratory is collocated with the Bassett Army Hospital at Fort Wainwright where joint clinical investigation into the prophylaxis, pathogenesis, and therapy of cold injury is conducted.

US Army Institute of Dental Research
Washington, D. C. 20012

The United States Army Institute of Dental Research is the only Army dental research facility supporting the unique practice of military dentistry. Of special interest to the Institute is research into the care and treatment of maxillofacial injuries. The professional complement has, in addition to advanced specialty training, also practiced military dentistry, thereby assuring pertinent problem recognition and practical military solutions. The information gained minimizes the lost duty time of the Army's treatment cost and expands the professional treatment capability.

U. S. Army Medical Research Unit (WRAIR) Brasilia
Tropical Medicine Research Building
University of Brasilia
Brasilia, Brazil

Testing of a minimum of 20 compounds weekly for activity against schistosomiasis mansoni. The Mortality Test System is utilized to evaluate activity of candidate drugs in mice exposed to schistosoma mansoni cercariae.

U. S. Army Medical Research Unit - Belem (Trans-Amazon)

The construction of the Trans-Amazon Highway, and attendant introduction of new populations, is considered somewhat analogous to the deployment of troops into new territory. Transients and new residents can be considered as human sentinels for the identification of disease transmission, thus disclosing specific targets for detailed investigation of diseases of military importance. Specific investigations are planned to define vectors, the response to chemotherapeutic agents, and conditions influencing rates of disease transmission. The methodology to be employed is that of prospective field surveillance in population subgroups identified by demographic characteristics. Diseases known to be present in this area include malaria, schistosomiasis, Altamira hemorrhagic disease, viral encephalitis, and yellow fever.

U. S. Army Medical Research Unit (WRAIR) Kenya
Nairobi, Department of State
Washington, D. C. 20520

The objective of the research program is to develop a militarily useful vaccine against African trypanosomiasis. An indirect benefit is the acquisition of an essential knowledge of the evolution of the disease in man and bovines, its immunopathologic aspects, and the various mechanisms of immunity that are involved.

U. S. Army Medical Research Unit (WRAIR) Malaysia
Kuala Lumpur, Department of State
Washington, D. C. 20520

Primary emphasis has been on field and laboratory studies to define the epidemiology, infectivity, and immunology of rickettsial diseases in Malaysia, especially scrub typhus. Studies on malaria have been concerned with vectors and chloroquine resistant Plasmodium falciparum. Other studies have been concerned with melioidosis, arbovirus isolations from

wild-caught mosquitoes, zoonotic infections, and antigenic analyses in selected strains of Rickettsia tsutsugamushi. In addition to its research in infectious diseases, the laboratory investigates procedures by which feral animals can be colonized for research purposes.

U. S. Army Medical Research Unit (WRAIR) Panama
Box 2011, Balboa Heights, Panama

Current research objectives are to determine the effect of chemotherapy on serum antibodies of patients with cutaneous leishmaniasis and with secondary mucocutaneous disease; evaluation of the disease vector potential of and vector control possibilities for selected anthropods; and to gather information concerning the reservoir status, modes of transmission, and pathogenesis of infectious diseases produced by important zoonotic agents.

U. S. Army Medical Component, SEATO
APO San Francisco 96346
(Bangkok, Thailand)

Current research is concentrated on dengue, hemorrhagic fever, rabies, malaria, and trials of new antimalarial drugs.

LEAD LABORATORY ASSIGNMENTS

A. GENERAL. The US Army Medical Research and Development Command (USAMRDC) has not, as of the date of this report, formally established the lead laboratory system within the Command. In practice, the Command has been following a concept of laboratory specialization similar to the lead laboratory approach in order to eliminate unnecessary or duplicative research efforts. This concept has led to the areas of specialization summarized in the following table:

SUMMARY OF AREAS OF MEDICAL RESEARCH SPECIALIZATION

AREA	LABORATORY
Auditory and Hearing Protection	USAARL
Aviation Medicine (Low Altitude & Rotary Wing)	USAARL
Blood Transfusion	LAIR
Burn Research and Treatment	USAISR
Dental	USAIDR
Dermatology	LAIR
Entomology	
Entomology (except repellents)	WRAIR
Repellents	LAIR
Environmental	
Heat, Cold, Physical Fitness	USARIEM
Terrestrial Altitude	USARIEM
Environmental Quality	USAMBRDL
Experimental Psychology	LAIR
Laser Effects	LAIR
Medical	
Arbovirus research	USAMRIID
Drug Addiction	WRAIR
Hepatitis	WRAIR
Leishmaniasis	LAIR
Malaria Drugs	WRAIR
Medical Defense, Biol. Agents	USAMRIID
Nutrition	LAIR
Parasitology (except leishmaniasis)	WRAIR
Plague	WRAIR
Microwave Effects	WRAIR
Military Medical Equipment	USAMBRDL
Primate Development	LAIR
Prosthetics and Related Materials	USAMBRDL
Visual Sensory Physiology	USAARL
Surgery	LAIR

B. DISCUSSION AND ANALYSIS.

1. The concept of laboratory specialization outlined above has been effective in eliminating unnecessary duplicative research efforts within the Command. In practice, it achieves the desirable benefits of the lead laboratory approach.

2. Until recently, with a few exceptions, these areas of specialization have not been formally identified, and thus some of the other benefits of the lead laboratory approach have not been attained, e. g. , ready identification by the other Services of the Army laboratory having responsibility for a given medical research and development area. This has not been seen as a problem, since the US Army Medical Research and Development Command Headquarters acted as the point of contact.

3. On the other hand, where the lead laboratory approach (for the purpose of marshaling and focusing R&D resources engaged in the solution of a specific, critical military operational problem and where such designation is ad hoc in nature) applied directly to the medical research and development area, significant disadvantages and inefficiencies would result. These stem from the unique and politically sensitive problems of utilization of patients and human subjects in medical research. All such research involving patients or human subjects must be reviewed by The Surgeon General's Committee on Human Research prior to the initiation of the research. All contracts must be similarly reviewed before the contract is approved for funding. This type of review is required under pertinent Federal Regulations; Memorandum of Understanding between the Department of Health, Education and Welfare and the Department of Defense concerning investigational use of drugs by Department of Defense, 29 Nov 74; and AR's 40-7, 40-38, and 70-25. Because the medical research and development program must comply with these additional requirements, application of the lead laboratory concept within USAMRDC must differ from its application within USAMC by retention of the responsibility for final approval of projects, contracts and collaborative work at the Command Headquarters level.

C. CONCLUSIONS.

1. Significant advantages in the form of increased and more effective communication would result if the USAMRDC formally utilized the lead laboratory approach in identifying laboratories having responsibilities for given areas of the medical research and development program.

2. Application of the lead laboratory approach in the medical research and development field must recognize the unique and politically sensitive problem of utilization of human subjects and patients in medical research by retaining approval authority for projects and contracts in HQ, USAMRDC rather than by delegating such authority to the individual laboratories in the Command.

D. RECOMMENDATIONS. It is recommended that the USAMRDC formally utilize the lead laboratory concept but retain the final approval authority for projects and contracts at the Headquarters level. A proposed listing of research areas by laboratory is provided in the table to follow.

PROPOSED LISTING OF LEAD LABORATORIES WITHIN
USAMRDC

LABORATORY	RESEARCH AREA
WRAIR	Entomology (except repellents) Drug Addiction Hepatitis Malaria Drugs Parasitology (except leishmaniasis) Plague Microwave Effects Tropical Diseases
LAIR	Blood Transfusion Dermatology Repellents Experimental Psychology Laser Effects Leishmaniasis Nutrition Primate Development Combat Surgery (except Burns)
USAISR	Burn Research and Treatment
USAARL	Aviation Medicine Visual Sensory Physiology Auditory and Hearing Protection
USAMBRDL	Environmental Quality Military Medical and Dental Equipment Prosthetics and Related Materials
USAMRIID	Medical Defense, Biol. Agents Arbovirus Research
USARIEM	Cold/Heat Effects/Physical Exercise Terrestrial Altitude Effects
USAIDR	Maxillofacial Wounds Physical Properties of Dental Material

INTERDEPENDENCY
(Lead Services)

AFRRI

NUCLEAR WEAPONS EFFECTS & IONIZING RADIATION

APPENDIX I



LAB SIZE (INCL MED HQ)

	<u>FY 71</u>	<u>FY 72</u>	<u>FY 73</u>	<u>FY 74</u>
ARMY				
MED	3039	2997	2883	3007
HR	<u>213</u>	<u>271</u>	<u>302</u>	<u>446</u>
	3252	3268	3185	3453
NAVY				
MED	1145	1215	1327	1350
HR	<u>471</u>	<u>439</u>	<u>322</u>	<u>288</u>
	1616	1654	1649	1638
AIR FORCE				
MED	1202	1154	1106	1088
HR	<u>343</u>	<u>367</u>	<u>383</u>	<u>367</u>
	1545	1521	1489	1455
ALL MED	5527	5469	5548	5608
ALL HR	<u>1027</u>	<u>1077</u>	<u>1007</u>	<u>1101</u>
ALL MED & HR	6554	6546	6555	6709

PROPOSED STRUCTURE FOR PLANNING
THE MEDICAL AND HUMAN RESOURCES TECHNOLOGY BASE PROGRAM

MEDICAL AND HUMAN RESOURCES R&D PLANNING GROUP

AD(E&LS) + MA(HR)	
ARMY - MED	NAVY - MED
ARMY - HR	NAVY - HR
	AIR FORCE - MED
	AIR FORCE - HR

SUBGROUPS
(CHAIRMAN BY LEAD SERVICE)

HUMAN ENGINEERING

BIODYNAMICS (INCLUDES ACCELERATION, VIBRATION,
IMPACT AND BIOACOUSTICS)

RADIOBIOLOGY (INCLUDES IONIZING, NON-IONIZING
RADIATION, AFRRI AS A MEMBER)

INFECTIOUS DISEASES (INCLUDES MEDICAL ASPECTS OF
CHEMICAL & BIOLOGICAL DEFENSE)

SURGERY AND COMBAT MEDICINE

TRAINING AND EDUCATION (INCLUDES TRAINING
SIMULATION TECHNOLOGY)

PERSONNEL SYSTEMS (INCLUDES SELECTION, DRUG ABUSE, ETC)

ENVIRONMENTAL PHYSIOLOGY

HEALTH CARE TECHNOLOGY

DENTAL RESEARCH



DEPARTMENT OF THE ARMY
OFFICE OF THE ASSISTANT SECRETARY
WASHINGTON D.C. 20310

25 MAY 1976

MEMORANDUM FOR: DIRECTOR OF DEFENSE RESEARCH AND ENGINEERING

SUBJECT: Draft of Medical and Human Resources Laboratory Utilization
Study Final Report

1. This is in reply to your Memorandum of 7 May 1976, on the above subject. Army comments and rationale are provided in the paragraphs below. These include the implementing actions now in progress on changes being made in consonance with the report recommendations.

2. The report recommendations of major concern to the Army are as follows:

a. Combine the US Army Research Institute for the Behavioral and Social Sciences with the US Army Human Engineering Laboratory, assign the combination to DARCOM with staff monitorship in DCSRDA and charter the new lab with an Army-wide mission. This recommendation is unacceptable. The merger of ARI and HEL in the interests of providing the Army a focal point for common program planning and execution for human resources research is completely inappropriate. Both organizations have a long history and a separate identity readily recognized in the Army. The insignificant monetary savings which might be realized by such a merger are outweighed by the different missions of ARI and HEL in the systems life cycle development process. ARI's efforts focus on serving DCSPER's Army-wide mission of developing personnel concepts, doctrine, tactics and training individual soldiers for combat. HEL is responsible for the application of human engineering to Army materiel design, developing standards and specifications for direct use in hardware development for DARCOM. The Research Office, ODCSPER, HQDA, provides the appropriate integration of the ARI and HEL programs for Department of the Army. The present organizational alignment of ARI and HEL is most adequate, and this position is emphatically concurred in by DARCOM, DA DCSPER, and DA DCSRDA.

b. Form a tri-service helicopter aircrew R&D "center" at Fort Rucker. Concur in this recommendation. A great deal of tri-service

SUBJECT: Draft of Medical and Human Resources Laboratory Utilization Study Final Report

R&D and training is already being accomplished at Ft. Rucker. Furthermore, Ft. Rucker has performed in a most outstanding manner in the area of flight simulation techniques which has proven to be highly responsive to the DOD goal to reduce actual flight hours by 25% by 1980.

c. Explore the concept of "interdependency" among the three services in those research topics of principal interest to one service and of peripheral interest to others or in those topics of strong interest to all three. Implementation of the concept and the topics to be included remain to be worked out. The result would be the designation of a "lead service" in each of the agreed upon topics. Interdependency is acknowledged as a viable concept whereby unwarranted duplication of technology base research is avoided through awareness of and reliance upon the efforts of another Service which may satisfy mutual needs in a specific area. Interdependency per se, however, does not imply the need for designating lead Services for associated areas. The proposed mechanism of coordinating the functions of program planning and execution through an ODDR&E/Joint-Service Planning Group is viewed as an adequate and appropriate mechanism for achieving the desired goal.

d. Establish an ODDR&E/Joint-Service R&D Planning Group. Planning for both medical and human resources R&D would be combined under this group. The group would discharge the program planning and budget review activities now carried out between each Service and ODDR&E. The idea has merit. The Medical and Human Resources Technology Base Planning Group as a common, coordinated, planning mechanism or vehicle could be most useful if it were functioning in lieu of the lead Service concept for most major technical sub areas. This notion tracks very well with the proposal of the Tri-Service Human Factors Topical Review Working Group to establish a Human Factors Advisory Group which would review and categorize the area, and promote cooperative, coordinated, collaborative and non-duplicatory efforts, identify technology gaps, update TCPs, and guide preparation for topical reviews.

e. Realign the Biomedical Lab under the supervision of USAMRDC. Non-concur in this recommendation. Action has already been taken to remove objectionable work from the BML program with the expectation that its future mission will be limited to Biomedical defense against chemical warfare. An arrangement agreeable to The Surgeon General and the Commander, DARCOM, has been reached concerning responsibilities for the work of this Laboratory.

SUBJECT: Draft of Medical and Human Resources Laboratory Utilization
Study Final Report

3. Additional detailed comments pertaining to the draft study are at
Tab A.

1 Incl
Tab A - Comments

K. C. Emerson

K. C. Emerson
Acting Assistant Secretary of the Army
(Research and Development)

ADDITIONAL COMMENTS PERTAINING TO THE DRAFT OF
MEDICAL AND HUMAN RESOURCES LABORATORY UTILIZATION STUDY FINAL REPORT

Item No.	Page No.	Para- graph	Line No.	<u>Recommended Changes and Reason</u>
1	iv		1	Change "AAML" to "AMRLA;" insert "Research" after "Medical." Reason: Correct designations.
2	iv		20	Change BRL to BML, and delete <u>Research</u> from Bio-medical <u>Research</u> Laboratory. Reason: Correct designations.
3	iv		23-24	Add: DARCOM, US Army Materiel Development and Readiness Command.
4	iv		24	Change DCS/RDA to DCSRDA. Reason: Correct Army usage.
5	iv		25	Change DCS Personnel to DCSPER. Reason: Correct Army usage.
6	v		29	Change <u>Aviation</u> to <u>Aeromedical</u> . Reason: Correct designation of USAARL.
7	5		(Fig.1)	Change DCS/RDA to DCSRDA, DCS/PER to DCSPER, and BRL to BML. Reason: Correct Army usage.
8	5		1	Change AMC to DARCOM and AMRDC to USAMRDC. Reason: Correct designations.
9	6			Change (BRD) to (USAMBRDL); Change USARIEM civ to 77 and total to 160; Change USAARL civ to 45 and total to 99. Reason: Correct information.
10	7	2	1	Delete Research from Laboratory title. Reason: Correct title.
11	7	2	5	Delete "Army Materiel Command," substitute "Army Materiel Development and Readiness Command (DARCOM). Reason: Correct title.
12	7	2	8,10	See item 11.
13	8	1	8	See item 11.
14	8	1	11	See item 4 (DCSRDA).

<u>Item No.</u>	<u>Page No.</u>	<u>Para- graph</u>	<u>Line No.</u>	<u>Recommended Changes and Reason</u>
15	15	3	7	Change ". . . retain final approval authority" to read ". . . require human use and legal review, and contracting authority . . ." Reason: Laboratories have expertise for complete technical evaluation and may be delegated authority for approval on technical/scientific grounds. However, Headquarters must continue human use, legal review and contracting authority until such time as expertise in these areas is developed in the laboratories.
16	15	3	10	Delete sentence beginning "This recommendation . . ." Reason: This sentence appears to be an editorial comment, provided without supporting discussion.
17	15	5	5	Add "as" after "flexibility" to restore meaning of the sentence.
18	16	4	11	See item 4 (DCSRDA).
19	16	4	12	See item 5 (DCSPER).
20	17	4	5	See item 11 (DARCOM).
21	17	5	5	See item 11 (DARCOM).
22	17	6	1	ATDA will be absorbed by PM TRADE in July 1976. A new 6.2 Program Element, 6.27.27A, "Non-Systems Training Device Technology," has been established in the FY 77 budget at \$2.6 Million.
23	22	4.1	9	After ". . . global defense operations . . ." add ". . . particularly in the prevention of militarily-significant disease problems . . ." Reason: Emphasizes R&D role in prevention of disease; of major impact to global operations.
24	27	4	1	Change "Army Biomedical . . . Grounds" to "Biomedical Laboratory, Edgewood Arsenal, Aberdeen Proving Ground. Reason: Correct designations.
25	27	4	5	Change "Army Materiel Command" to "DARCOM." Change "Aberdeen" to "Biomedical Laboratory." Reason: Many other research programs exist at Aberdeen.
26	27	4	7	Insert "DARCOM" after "other."
27	27	5	4	See item 5 (DCSPER).

<u>Item No.</u>	<u>Page No.</u>	<u>Para-graph</u>	<u>Line No.</u>	<u>Recommended Changes and Reason</u>
28	27	5	5	See item 11 (DARCOM).
29	27	5		Coordination and integration of the ARI and HEL resources and functions are currently effected by the Research Office of DCSPER, wherein lies responsibility for monitoring both laboratories. Two new regulations: AR 602-1 (Human Factors Engineering Program) and AR 70-8 (Personnel Performance and Training Program) define improved management procedures and policies for these programs.
30	28	1	4	See item 11 (DARCOM).
31	28	1	5	See item 4 (DCSRDA).
32	29	2	13	Change "Army's Natick Laboratories" to "Army's Natick Research and Development Command." Reason: Correct title.
33	29-30	5-1		The recommendation that the Navy prepare a 5 year plan in coordination with the Air Force entirely overlooks Army's interest and expertise in aviation medicine. It is critical that aviation medicine research be fully tri-service coordinated. Reason: While the Army's areas of interest are relatively narrower than either the Navy or Air Force, Army capability is unique, and broadly applicable.
34	37	3		The Tri-service Aeromedical Research Panel and the Tri-service Electromagnetic Research Planning Group already exist and are providing various degrees of tri-service planning and coordination in their areas (others also exist, such as the Tri-service Human Factors Working Group). It is recommended that these models continue to perform their functions, that they be supplemented with similar additional panels or working groups in the other R&D areas, and that in their aggregate they constitute the Medical and Human Resources Technology Base Planning Group. It is also recommended that this parent planning group be chaired on a rotational basis by representatives from each of the military departments. This would reduce considerably the time requirements placed upon the ODDR&E staff. Participation of the ODDR&E in R&D management could

<u>Item No.</u>	<u>Page No.</u>	<u>Para- graph</u>	<u>Line No.</u>	<u>Recommended Changes and Reason</u>
34 (Cont'd.)				then be effected by having the ODDR&E exercise review and approval authority over the activities of the Planning Group. In the list which follows on Page 38, add "Environmental Quality and Toxicology." Reason: Completeness. List "Bioacoustics" separately from "Biodynamics." Reason: Accuracy.
35	38	2		The Army already has an independent peer review mechanism for the medical and human resources research portion of the program. Addition of another DOD level peer review mechanism, which is the apparent intent, would increase the bureaucratic layering, without improving program effectiveness.
36	40	3	9	Change "Sergeons" to "Surgeons."
37	41	4.7.2		The Arctic Medical Research Laboratory (AMRLA), a former component of the US Army Research Institute of Environmental Medicine (USARIEM) has been disestablished and redesignated the Arctic Medical Research Facility (AMRF). There is no permanent staff assigned to the facility; research teams from USARIEM will utilize the AMRF on a seasonal basis for selected field studies of cold injury and cold weather operations. Recommend that paragraph 4.7.2 be changed to reflect the above information or that it be incorporated elsewhere by inclosure or appendix to the Laboratory Utilization Study.
38	56	1		Add "Biomedical Laboratory."
39	56	1		Change "Natick Laboratories" to "Natick Research and Development Command." Reason: Correct title.
40	64	8		(WRAIR) delete. Reason: The Division of Biological Sensor Research will be disestablished 1 Jul 76 and the research conducted by that division will be terminated effective that date.
41	67	1		(USAMRIID) delete. Reason: Not germane. Renumber remaining USAMRIID paragraphs.
42	68	2		(USARIEM) change "Arctic Medical Research Laboratory" to "Arctic Medical Research Facility." Reason: Correct title.

<u>Item No.</u>	<u>Page No.</u>	<u>Para- graph</u>	<u>Line No.</u>	<u>Recommended Changes and Reason</u>
43	68	3		(AMRLA) change title to "Arctic Medical Research Facility (AMRF), Alaska (USARIEM)." Reason: Correct title. Change paragraph to read: "The AMRF is the only US military medical facility in the Arctic with the equipment and facilities for . . . environment. The Alaskan facility provides . . . operations. The facility is collocated with Bassett Army Hospital at Fort Wainwright and is used by research personnel from USARIEM (Natick MA) to support field studies as required.
44	70	2		Current research involves Phase III (field) testing of new curative and suppressive prophylactic anti-malarial drugs; investigations of dengue shock syndrome; dengue virus isolation systems; characterization of the immune response in dengue shock syndrome; modes of transmission for hepatitis; bio-systematic studies of mosquitoes; studies of filariasis vectors; evaluation of systemic miticides; studies of mosquito pathogens; studies of the immune response during malaria infections.
45	71	1		Table "Summary . . ." replace "Auditory" with "Bioacoustics." Reason: Correct designation.
46		14		Delete "Experimental Psychology - LAIR." Reason: Mission deleted from LAIR; is included in WRAIR Military Psychiatry mission area.
47		17		Arbovirus research, laboratory should be WRAIR, vice USAMRIID.
48		18		Delete "Drug addiction" WRAIR. This mission deleted by Congressional action.
49				Insert Military Psychiatry - WRAIR after line 27. Reason: Correct WRAIR mission area list.
50	72	C.2	4	Delete all following " . . . medical research." Add sentence "All projects and contracts which involve human subjects must continue to be subject to final review by HQ, USAMRDC, notwithstanding delegation of technical/scientific approval of same contracts to the individual laboratories in the Command. Reason: Conforms more closely with current policy.

<u>Item No.</u>	<u>Page No.</u>	<u>Para- graph</u>	<u>Line No.</u>	<u>Recommended Changes and Reason</u>
51	73			D. Recommendations. Change to read: "It is recommended that the USAMRDC continue its development of the lead laboratory concept. Initially, at least, Headquarters, USAMRDC will need to continue review of proposals for human and animal use, and legal implications. This can best be maintained by retaining contracting authority at the Headquarters. A proposed listing of research areas by laboratory is provided in the table to follow." Reason: More accurately reflects current policy trend.
52	74			Laboratory research area: WRAIR, delete: drug addiction, add: basic infectious disease, add: military psychiatry, add: military preventive medicine; LAIR, add: basic medical and surgical physiology; delete: experimental psychology; delete: Leishmaniasis. USAARL, change "Auditory" to "Bioacoustics." USAMBRDL, delete: Prosthetics and related materials. USAMRIID, delete: Arbovirus Research, add: Hazardous microorganisms vaccine development. Reason: To correspond more closely with present mission alignment.



DEPARTMENT OF THE NAVY
OFFICE OF THE ASSISTANT SECRETARY
(RESEARCH AND DEVELOPMENT)
WASHINGTON, D.C. 20350
2 June 1976

MEMORANDUM FOR ASSISTANT DIRECTOR, ENVIRONMENTAL AND
LIFE SCIENCES, ODDR&E

Subj: Draft of Medical and Human Resources
Laboratory Utilization Study Final Report

Ref: (a) ODDR&E Memo of 16 Apr 1976, same subject
(b) ODDR&E Memo of 7 May 1976, same subject

Encl: (1) Errata, Draft Medical and Human Resources
Laboratory Utilization Study

Reference (a) transmitted subject report and requested a review for accuracy as well as comments on conclusions and recommendations. Reference (b) changed the due dates.

This memorandum transmits, as enclosure (1), Errata, and is the result of a review for accuracy only. Comments on conclusions and recommendations will be forwarded as a separate action.

SAMUEL KOSLOV
SPECIAL ASSISTANT (SCIENCE)

APPENDIX M

ERRATA, DRAFT MEDICAL AND
HUMAN RESOURCES LABORATORY UTILIZATION STUDY

Page V

Change "Naval Aviation Medical Research Laboratory" to "Naval Aerospace Medical Research Laboratory"

Delete "NIDH Naval Institute of Dental Health" and substitute "NDRI Naval Dental Research Institute"

Change "Naval Personnel Research and Development Command" to "Navy Personnel Research and Development Center"

Page 8. Section 2.2

Change "Naval Medical R&D Commands" to "Naval Medical R&D Command"

Page 8. Section 2.2.1

Change to read "....R&D activities are conducted in twelve laboratories; ten under the Naval Medical R&D Command...."

Page 9. Table 2-1

Suggest deleting the Toxicology Unit, NNMC line, since this Unit was amalgamated with NMRI in May 1975. Deletion will make the text on Page 8 and the table more consistent. Also, delete footnote.

Change "Naval Aeromedical Research Laboratory" to "Naval Aerospace Medical Research Laboratory"

Page 10

Change "Naval Personnel R&D Center" to "Navy Personnel R&D Center"

Change "Michaud" to "Michoud"

Change "Bureau of Personnel" to "Bureau of Naval Personnel"

Page 19. Par. 4

Change "NIDH" to "NIDR"

Change "Medical Field Research Laboratory"
to "Naval Medical Field Research Laboratory"

Change "Submarine Medical Research Laboratory"
to "Naval Submarine Medical Research Laboratory"

Page 26. Par. 1

Change "NAML" to "NAMRL"

Page 28. Par. 3

Change to read "....coordinating the work
of 10 of the Navy's medical laboratories"

Page 28. Par. 5

Change to read "....outside of the NMRDC
which coordinates the work of 10 other Navy
medical laboratories...."

Page 29. Par. 4

Change "Michaud" to "Michoud"

Delete last word of page

Page 30. Par. 1

Change "Michaud" to "Michoud"

Page 32. Par. 1

Change "Principle" to "Principal"

Page 32. Par. 2

Change "decase" to "decade"

Page 39. Par. 4

Change "National Institute of Dental
Health" to "National Institute of Dental
Research"

Page 40. Par. 3

Change "Sergeons" to "Surgeons"

Page 56.

Page II-3 and II-4 of the Navy Study show the correct information and organizational titles

General Comment:

Recommend deletion of Appendices G and H. The type of information contained in G and H should either be presented for all 3 services or for none of them.

Figure 2.

This figure is not quite correct. We will discuss the nature of the desired information with ODDR&E representatives when the report is being revised, and then submit a revised figure.



DEPARTMENT OF THE NAVY
OFFICE OF THE ASSISTANT SECRETARY
(RESEARCH AND DEVELOPMENT)
WASHINGTON, D.C. 20350
3 June 1976

MEMORANDUM FOR THE DIRECTOR OF DEFENSE RESEARCH AND ENGINEERING

Subj: Draft of Medical and Human Resources Laboratory
Utilization Study Final Report

Ref: (a) ODDR&E Memo of 16 April 1976, same subject
(b) ODDR&E Memo of 7 May 1976, same subject

Encl: (1) Navy Response to subject report

Reference (a) transmitted subject report and requested a review for accuracy as well as comments concerning the general and specific conclusions and recommendations. Reference (b) established a schedule of related actions.

Enclosure (1), the Navy Response to subject report deals with substantive conclusions and recommendations. Errata will be forwarded by separate memorandum.

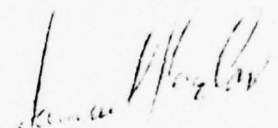
SAMUEL KOSLOV
SPECIAL ASSISTANT (SCIENCE)

NAVY RESPONSE TO
THE
DRAFT FINAL REPORT OF THE DDR&E
MEDICAL AND HUMAN RESOURCES
LABORATORY UTILIZATION STUDY

INTRODUCTION

The Navy response to the Draft Final Report of the DDR&E Medical and Human Resources Laboratory Utilization Study (hereafter referred to as the Report) is in three major parts. The first part describes the general features of the Navy structure for R&D management. This will provide a frame of reference for considering the recommendations. Next will be a discussion of the major thrusts of the Report and general comments will be made on these points. Finally, there will be comments on the specific recommendations.

The response was coordinated with the following: Chief of Naval Research, Chief of Naval Development, Surgeon General, Director of Naval Laboratories, Director of Research, Development, Test and Evaluation, Deputy Chief of Naval Operations (Manpower and Logistics), Director of Naval Education and Training, and Assistant Secretary of the Navy (Research and Development).

The Navy R&D Management Structure

An important context for the Navy response to the Report is the structure by which the Navy manages all of its R&D. Since many of the responses to specific recommendations are based on this structure, a brief summary is presented here. The Navy opposes those recommendations that would create special procedures for dealing with medical and human resources R&D. It believes that the uniqueness of procedures thus created would make for great problems of integration with the programming and budgeting system, as well as with Navy planning procedures.

Overall responsibility for R&D in the Navy is vested in the Assistant Secretary of the Navy (R&D). The management of the effort is delegated as follows: Research is managed by the Chief of Naval Research; Exploratory Development by the Chief of Naval Development; and Advanced, Engineering and Operational Systems Development by the Chief of Naval Operations.

There are a number of inter-relationships among these managers that bring the various kinds of R&D into a coordinated whole. The Chief of Naval Operations develops Science and Technology Objectives to provide a statement of problem areas and needed capabilities. These are

provided to the Chief of Naval Research and Naval Development, who use the objectives as one source of guidance for research and exploratory development. The problems posed by the Science and Technology Objectives are long range--5 to 20 years in the future.

For Advanced, Engineering and Operational Systems Development programs are documented in Navy Decision Coordinating Papers (NDCPs). NDCPs may be initiated by one of three processes:

1. An Operational Requirement (OR) may be developed and approved within the Office of the Chief of Naval Operations (OPNAV), and transmitted to the Chief of Naval Material or the Chief of the Bureau of Medicine and Surgery who prepares a Development Proposal (DP). This document provides a basis for the NDCP.
2. The Chief of Naval Material (CNM) or the Chief of the Bureau of Medicine and Surgery proposes Advanced System Concepts (ASC), which, if found acceptable to the Office of the Chief of Naval Operations, may form the basis for an NDCP.
3. The appropriate sponsor and an R&D agency may simply negotiate an NDCP, which is then staffed, approved and promulgated by the Director of Research, Development, Test and Evaluation.

For Advanced, Engineering and Operational Systems Development efforts, an important role is played by the OPNAV Deputy Chief of Naval Operations and Directors of Major Staff Offices. For their assigned programs, these key staff officers are designated as sponsors. As sponsors, they determine the level of funding and the priorities among various efforts within their assigned programs.

The relationship between a sponsor and his assigned R&D programs is very important. As the office with the problem, or with a need for a new capability, he provides the tie between the R&D community and the operating Navy. The sponsor also assists with the implementation of results.

The first Laboratory Utilization Study, of the Engineering and Physical Science Laboratories, pointed out that Congress has insisted on military relevance in DOD R&D. It is through the sponsor system that the Navy validates the military relevance of its R&D.

In summary, there are two principal features of the Navy structure that should be kept in mind:

1. Different agencies manage the various kinds of R&D programs. These agencies are headed by the Chief of Naval Research for Research,

the Chief of Naval Material for Exploratory Development and the Chief of Naval Operations for Advanced Development and all other programs.

2. The OPNAV Sponsors play an important role in defining the military relevance of the R&D effort, and in supporting 6.3 and 6.4 work through the Program Objectives Memorandum (POM) and Budget processes.

THE THRUSTS OF THE REPORT

This section of the Navy comments will deal with the major thrusts of the Report, and provide a rationale for comments on the specific recommendations.

There are two major themes stressed in the report with which the Navy wholeheartedly agrees. These themes are:

1. The need for improved coordination within the Navy Human Resources* R&D Program, and between it and selected aspects of the Navy Medical R&D Program.
2. The need for improved coordination among the Services.

Specific approaches to these ends will be proposed that will be consistent with the Navy's overall R&D management structure.

Better Coordination of the Navy Human Resources R&D Program

The Report proposed to coordinate the Navy Human Resources R&D Program by means of centralized management, funding and planning of 6.2 and 6.3 work by the Navy Personnel R&D Center (NPRDC). While agreeing with the goal of better coordination, the Navy must reject this specific proposal, for the following reasons:

1. This proposal will set up a special, fenced, area that is exempt from the normal Navy management structure as described in the preceding section, and will thus create many administrative problems in terms of defining needs and requirements, and in POM and budget development.

2. NPRDC was formed in 1973 out of three former personnel and training laboratories. Since that time, a significant part of the Center's effort has been occupied with becoming organized, establishing programs and obtaining key staff. In May 1975 it became a

*The term "Personnel and Training" is now being used by DDR&E in lieu of "Human Resources". These should be considered synonymous wherever they occur in the comments.

member of the Navy Material Command Laboratory System, consistent with ODDR&E recommendations, which in turn meant additional adjustment had to take place. NPRDC is not currently staffed to perform the recommended planning and management functions, nor is it suitably placed in the Navy organizational structure for this purpose.

3. NPRDC's mission includes the coordination of Navy human resources R&D, and it is developing a capability to perform that part of its mission. The Navy proposal will take advantage of that capability.

The alternate proposal of the Navy is as follows:

1. Since Navy Human Resources R&D is managed by the Chief of Naval Research for 6.1., the Chief of Naval Development for 6.2, and the Chief of Naval Operations for 6.3 and 6.4 there will be established a Navy Personnel and Training (new term to replace Human Resources) Steering Committee which will consist of professional representatives of the Chief of Naval Research, Chief of Naval Development, Director of Research, Development, Test and Evaluation (OP-098), and the Sponsors of personnel and training development.

2. There will also be established a Navy Personnel and Training Advisory Committee. This Committee would be composed of representatives of the various performing organizations of the Navy Personnel and Training R&D Program, the Commandant of the Marine Corps, and the Naval Medical R&D Command. This Committee would, under the guidance of the Steering Committee, review and develop appropriate inter-relationships among the managers and performing laboratories of the Navy program. It would also deal appropriately with those medical areas that are closely related to the Personnel and Training R&D program.

3. In fulfilling its coordination function, NPRDC will collect and disseminate information concerning the program to sponsors, managers and performing organizations, conduct analyses and technological assessments, and recommend program modifications to the Advisory and Steering Committees. In this activity it would be tasked by the Steering Committee.

This arrangement will maintain the Navy's management structure and its sponsor relationships, and at the same time, meet the DDR&E interests in improved coordination.

Better Tri-Service Coordination of Personnel and Training R&D Programs

The Report recommends the formation of a Joint Conference for Human Resources (or Personnel and Training), paralleling that for Medical R&D. The Navy agrees with this proposal, and with the concept of interdependence as defined on page 33 of the Report.

The Technology Base Planning Group

The Report also recommends an elaborate joint Medical and Human Resources planning system based on the assignment of broad areas to various Services under the concept of the lead Service. The Navy is opposed to this elaborate system on several grounds:

1. This proposal markedly encumbers and inhibits effective functioning of the Navy's established R&D management structure.
2. Only a few portions of the medical and human resources programs warrant the degree of integrated planning implicit in this proposal. Adoption of forced common planning for these two areas would be wasteful of time and effort.
3. The numerous meetings and reviews would not be cost-effective, and are, especially undesirable in the light of the personnel reductions that are taking place in Navy Headquarters.
4. The concept of assignment of major areas to lead Service, whose approval must be sought before work can be budgeted, is fraught with many difficulties.
 - a. This concept would seriously interrupt the POM-Budget process. The problems of getting lead Service concurrence in a timely manner would place an additional burden on an already burdened staff.
 - b. It is interesting to note that in a recent review of Training Devices and Flight Simulators, it was revealed that previously designated lead Services had not worked. The Army had formerly relied on the Navy for training device R&D and on NASA for flight research simulation, but in the past few years had been forced to develop its own programs.

The Navy favors the approach of working toward joint plans in

selected specific fields, that would be selected by the Joint Personnel and Training R&D Conference.

COMMENTS ON THE RECOMMENDATIONS

The Navy comments on the recommendations of the Report follow:

Recommendation: "The budget and program review process, while satisfactory, are 'at times excessive'. [The Study Group] recommended a reevaluation of these processes. (Page 19)

Response: Concur

Recommendation: "Development of a common personnel data base combining medical, dental, personnel and other information on individual members of the Navy for use in conducting longitudinal studies." (Page 20)

Response: We are opposed to omnibus data banks, presumably useful to anyone and everyone. Sufficient data system technologies now exist for medical and personnel histories (with Privacy Act clearance) and a dental data bank is being developed. It is important to define the specific purposes for which a data bank will be used before deciding to establish one.

Recommendation: "..... recommendations were made for a rebalancing or increase in effort in certain activities of the Navy Health Research Center, the Submarine Medical Research Laboratory" (Page 19)

Response: Concur

Recommendation: "This study identified a need to better incorporate these laboratories into the materiel acquisition and personnel management process and the structure for policy making when such policy affects the human element of the Military Department." (Page 22)

Response: Concur with the need to formulate and implement a mechanism for insuring medical and human resources laboratory input into these processes.

Recommendation: "A better [R&D product] marketing effort should be undertaken by these laboratories to assure not only that their current contributions are used, but also that the opportunities for making such contributions can be expanded." (Page 23)

Response: We agree with the concept that continual effort should be made to bring the R&D products of the laboratories to the attention of

the user community. There would, however, be less need for a "marketing drive" if the requirements for products were clearly identified and described by the intended user before development commences. This practice would minimize the number of potential "white elephants" emerging from the laboratories. Finally, in those instances where product marketing is necessary, we feel that the effort should not be undertaken by the research staff but rather by management.

Recommendation: "The programs of each of the laboratories covered by this study should be reviewed with the objective of identifying that work which should not be funded by Technology Base funds and appropriate funding for that work should be programmed." (Page 23)

Response: Concur. The Navy has well established procedures for reimbursing its laboratories with appropriate funds for work that does not contribute to the technological base.

Recommendation: "..... recommended that a Joint Human Resources Research Conference be established with membership from each of the Military Departments, chaired by an outside consultant and with the Military Assistant for Human Resources, ODDR&E as the Executive Secretary." (Page 24)

Response: Concur

Recommendation: "It should be established as a matter of principle that these laboratories [i.e. human resources] are technology laboratories, not analyses shops. It should be acknowledged that the rendering of assistance, appropriate data, and recommendations to the personnel policy decision makers is a legitimate and valuable function of the laboratories. And lastly, procedures to provide the resources required to accomplish this function from sources other than the Technology Base should be established. This is being partially accomplished by the Navy but not by the Army and Air Force." (Page 24)

Response: Concur

Recommendation: "The LUS study discussed at some length the urgent need to modify existing Civil Service practices and regulations insofar as they apply to R&D personnel and especially to those working in the laboratories. (See LUS Appendix E.) In addition to the recommendations made in the LUS, two additional specific recommendations were generated by this study. The first is that longer probationary periods be authorized for laboratory professionals. Such a change would lengthen the period of service before the employee would attain permanent employee status. The second recommendation suggests that professionals be employed on term contracts with renewal options to be granted at the discretion of the laboratory director." (Page 25)

Response: Concur, but with the proviso that a study be conducted prior to implementation to determine the implications of the proposal. While the recommendations are attractive to management, they may create such uncertainty among the staff as to bring on worse problems than they were intended to solve.

Recommendation: "A single program planning organization for human resources Technology Base work should be established in each Service." (Page 25)

Response: Concur in principle. The Navy has proposed, in the previous section of these comments, such an organization. This procedure also will permit coordination with the limited areas of medical R&D that are related to Personnel and Training R&D.

Recommendation: "It is recommended that each Military Department develop mechanisms for the joint planning of its Technology Base work in the [medical and human resources] areas, especially in the area of human factors, which is the area of closest interface between the two communities." (Page 25)

Response: We can envision no significant advantage to "joint planning" of all medical and human resources technology base work. Little benefit would accrue by having a joint planning group address such diverse technology areas as the prevention of malaria, occupational aptitude testing, treatment of septic shock, and job satisfaction/reenlistment relationships.

On the other hand, there are specific topical areas (e.g. manpower readiness forecasting, psychological adjustment to various duty assignments, occupational classification standards) in which inputs from the human resources and medical R&D communities should be integrated. In these areas, joint planning and coordination of effort is not only desirable but essential.

The system proposed by the Navy will effect coordination of work in these specific areas.

Recommendation: "It is recommended that the Army be designated lead Service for the conduct of all medical and human resources Technology Base work associated with the human aspects of helicopter operations." (Page 26)

Response: Agree with the Army having major responsibility for conducting medical tech base work relating to helicopter operations. However, Navy missions involving helicopters include some that are unique. These mission differences will impact on human factors engineering and training, including simulation. It is therefore preferred to coordinate the

human resources work with the Army to ensure there is no duplication. The Navy does not agree with the requirement to obtain Army approval before conducting its own R&D in this area.

Recommendation: "The development and maturing of the newly created Naval Medical R&D Command should be continued." (Page 28)

Response: Concur

Recommendation: "NMR&DC should be allowed, and in fact required, to participate in the selection of medical research contracts by the Office of Naval Research. At the present time, there is little evidence to indicate that active and full participation now exists." (Page 28)

Response: For medical research contracts funded by NMRDC, the NMRDC is fully responsible for proposal selection, and works on a continuing basis with the ONR monitoring officer. The ONR funded contract research program (CRP) uses peer review groups including NMRDC representatives to review proposals for scientific merit. The majority of current CRP contracts name an NMRDC representative for coordination and beginning with FY 77 all medical research contracts will require coordination with NMRDC.

Recommendation: "The Naval Biomedical Research Laboratory, Oakland, California, should be terminated as a Navy laboratory." (Page 28)

Response: The Navy does not plan to terminate NBL as a Navy laboratory. The Navy vitally requires a laboratory with a broad mission in basic and applied biosciences unrestrained by the mission and program responsibility of the CHBUMED. Such a laboratory addresses problems of a broad biological/ecological nature which fall outside of the purview of the BUMED laboratories. On 19 November 1975 the Navy changed the name of the Naval Biomedical Research Laboratory to the Naval Biosciences Laboratory (OPNAVNOTE 5450) with the mission to conduct research and development in biosciences related to the needs of the Naval Establishment. ONR Instruction 5450.5D stating the detailed mission and functions is in the final stages of preparation. The revised mission and function for NBL will preclude redundancy in the R&D programs of NBL and the NMRDC laboratories.

In view of current DDR&E emphasis on increased contract versus in-house effort the Navy does not wish to discontinue the unique NBL arrangement with the University of California in which the Navy provides specialized facilities and military personnel, and the University conducts the research.

Recommendation: "The Medical Field Research Laboratory, Camp Lejeune, should be converted from an R&D funded research facility to an O&M funded field medical unit." (Page 29)

Response: A proposal to disestablish the Naval Medical Field Research Laboratory was forwarded to the Chief of Naval Operations on 16 March 76. Selected R&D functions are to be transferred to other Navy laboratories with consequent increase in scientific productivity and responsiveness to operational requirements. The T&E functions of the laboratory will be accomplished by other Navy and Marine Corps activities, by the Army Medical Bioengineering R&D Laboratory, the Army Research Institute of Environmental Medicine and through out-of-house contracts.

Recommendation: "The Navy Toxicology Unit at Bethesda should be re-located to be collocated with the Air Force program at the Aeromedical Research Laboratories, WPAFB." (Page 29)

Response: The Navy Toxicology Unit has been integrated within the Naval Medical Research Institute since 1 May 1975. However, in view of the lack of long-term exposure facilities at NMRI and the increasing demand for data on chronic exposures to chemicals used by the Navy, a NMRI Toxicology Detachment is being established at the Aerospace Medical Research Laboratory, Wright-Patterson AFB. This Detachment will perform normobaric toxicological studies to develop dose-response relationships required for the establishment of permissible exposure limits. Research on hyperbaric and behavioral toxicology will continue to be conducted at NMRI.

Recommendation: "It is recommended that the Navy increase its emphasis in submarine medicine and in subsurface human factors R&D." (Page 29)

Response: As requirements for additional research in submarine medicine and human factors are identified and validated, funding commensurate with the magnitude and priority of the work will be sought and programmed.

Recommendation: "It is recommended that the Navy prepare a five-year plan for Naval aviation medicine and this plan be coordinated with the Air Force which conducts the major program in this area. The plan should include a detailed review of the future of the NADC Crew Systems Department and the NAMRL Detachment at Michoud, Louisiana." (Page 30)

Response: Concur

Recommendation: "The Navy should develop NPRDC as the responsible agent for planning and coordinating the Navy's 6.2 and 6.3A efforts in human resources to include the human factors functions. It should be organizationally reassigned from the Bureau of Personnel to the Director of

Navy Laboratories. The programs of the Human Factors Division of NELC, the Research Division of NTEC and the selection and training work of NAMRL should be placed under the control of NPRDC to assess the value of these current programs and to plan in integrated follow-on effort with the work assigned to the appropriate facility for accomplishment. All Systems Command funded human resources 6.2 and 6.3A work should be coordinated with NPRDC. Plans should then be formulated to transition these programs to NPRDC for management." (Page 30)

Response: There are several elements in this recommendation. Each will be discussed below:

1. With regard to NPRDC planning and coordinating the 6.2 and 6.3A work to include human factors:

a. The Navy has assigned to NPRDC the mission of coordinating all Navy Personnel and Training R&D, including human factors.

b. The Navy does not believe it appropriate at the present time for NPRDC to be the planning agent for this area of effort. It has proposed a procedure and a structure for planning the Navy's work in the preceding section.

2. The programs of the Human Factors Division of NELC, the Research and Technology Directorate of NTEC and the selection and training work of NAMRL will be planned in a coordinated way through the steering and advisory committees described previously, with NPRDC playing an important coordinating role.

3. Systems Command funded human resources 6.2 and 6.3 work will be coordinated with NPRDC, but the planning will be guided by the steering and advisory committees.

4. NPRDC has been transferred to NAVMAT since the completion of the study.

5. Other considerations bearing on this recommendation have been discussed in the previous section, in which the Navy proposes a planning and coordination organization that is consistent with the management structure that the Navy uses for all of its R&D.

Recommendation: "NPRDC should participate with ONR in planning the 6.1 human resources program. NPRDC should consider the establishment of additional field units collocated with users, for example, in the area of flight training." (Page 30)

Response: NPRDC currently participates in planning the 6.1 human resources program, and provides comments on specific proposals of mutual

interest when those proposals are received. Concur in having NPRDC consider the establishment of additional field units collocated with users.

Recommendation: "The Navy should acknowledge the concept of interdependency and participate in the follow-on effort to identify and agree to specific interdependency areas and lead Service responsibilities (See Section 4.3)." (Page 30)

Response: The Navy acknowledges and accepts the concept of interdependency as defined in the first sentence of Section 4.3, page 33, "Interdependency may be defined as the practice of avoiding unwarranted duplication of R&D by relying on another Service or Agency for part of the effort in a particular area of the Technology Base". There is an informal de facto form of interdependency which has proven to be quite effective. The Navy is not aware of any need for a formal effort to expand these areas of interdependency. The Navy feels the interdependency should be pursued through the existing mechanisms of JMRC, TCP, and Tri-Service Panels. The Navy favors interdependency in the form of groups of knowledgeable scientists carefully examining a limited area to coordinate across Services.

The Navy does not agree with the concept of a lead Service as defined in Section 4.3, lines 16-19, page 34. The concept has many drawbacks, some of which are listed as follows:

1. Imposes additional layers of administrative and technical management which interfere with orderly and timely programming and budgeting by the Navy and takes over decision making authority of top naval management.
2. Negates the Navy's R&D Planning, Management and Coordination System (OPNAVINST 5000.42A).
3. Discourages new and unusual approaches to the solution of naval problems by people or activities outside the lead Service hierarchy, while encouraging the "not invented here (NIH) syndrome".
4. Discourages the development and maintenance of a broad based, flexible, experienced and responsible naval medical and human resources research and development capability for the peacetime and wartime missions of the naval establishment.
5. Tends to discourage funding investment by services other than the lead service.

Recommendation: "Consequently, a common, coordinated planning strategy for conducting this segment of the Defense R&D program is essential to the optimum use of available resources. Accordingly, it is recommended that such a strategy be developed and a mechanism be established to implement it. Such a mechanism, the Medical and Human Resources

Technology Base Planning Group, is described in the following paragraphs." (Page 35)

Response: There are several major features to this recommendation, each of which requires comment:

1. Interdependency. The Navy favors interdependency, a Joint Personnel and Training R&D Conference, the existing Joint Medical R&D Conference and the examination of specialized areas by those who know them best to avoid duplication. We favor the continuation of such coordination practices as the Technology Coordinating Paper, the topical review, and the tri-service plan in special areas as identified by those mechanisms.

2. Lead Service. The Navy opposes this suggestion because history has shown that funds tend to dry up in the non-lead Services, and the lead Service does not look after the interests of the others. The case of the Army and simulation has already been mentioned.

3. Joint Medical and Human Resources Planning. As described before, there is not sufficient common interest to warrant this on a comprehensive and continuing basis. The individuals might meet a few times, but then the system would die. The Navy has proposed a system of planning its own Personnel and Training work that includes medical participation.

4. Chairmanship by the Assistant Director (Environmental and Life Sciences) in ODDR&E. The Navy is opposed because the need for its work is validated by the sponsors in OPNAV. The proposed system would cut the program away from its parent Service roots.

5. Peer Review. The Navy has an informed and effective peer review system in the Navy Research Advisory Committee.

6. Retention of the Joint Medical Research Conference. Concur.

Thus, while the need for a mechanism to ensure tri-service coordination of medical and human resources R&D program planning is recognized, the establishment of an ODDR&E Technology Base Planning Group to perform this function is considered undesirable and unwarranted. This position is further supported by the following considerations:

1. Establishment of the Planning Group would essentially transfer authority for medical and human resources R&D planning from the management

offices and commands of each Service to ODDR&E, leaving individual Services with responsibility for implementing higher level decisions and executing an ODDR&E-devised program. The separation of authority from responsibility is an undesirable management practice.

2. No single group, composed of part-time representatives from each Service, will be able to oversee and control R&D planning for all three Services. Such control properly resides within the Services where R&D capabilities, objectives and requirements are thoroughly understood and where the expertise required for effective planning is located. Moreover, it is unrealistic and unworkable to propose that "it would be essential that the Military Department representatives to these subgroups include the same individuals who are in a position to carry through their recommendations by programming of resources to the proposed work". Ultimate authority for allocation of resources does not reside with persons responsible for individual program areas (e.g. Surgery and Combat Medicine, Radiobiology, Infectious Diseases, etc.). Their recommendations are always subject to review and approval by one or more superiors. The proposed procedure would result in principal activity by the ODDR&E staff further reducing the interactions with the users and service relevancy.

3. Existing R&D panels (such as the Joint Medical Research Conference, the Tri-Service Panel on Electromagnetic Radiation, and the Tri-Service Panel in Impact, Acceleration and Vibration Research, as well as that for computers in training and education), which were convened by DOD expressly to prevent needless duplication of effort and to ensure inter-service communication in program planning, should be given a chance to succeed and, where the need exists, expanded to other technology areas. Such panels, established for each technology area being addressed by more than one Service, cannot only be alert to program redundancies but can ensure that program content is within each Service's capabilities and adequately responsive to its operational requirements.

We regard an annual in-depth program/budget review, consistent with current practice, involving the joint participation of appropriate R&D managers of the three Services and appropriate ODDR&E representatives, as a preferred alternative to an ODDR&E Technology Base Planning Group. Service-approved program plans, considering the recommendations of Tri-Service panels and consistent with TCP guidance, would be presented at the annual reviews. Obvious inter-service overlaps in program content and program deficiencies would surface before or during the reviews and an opportunity would be afforded to develop jointly plans which adequately address the unique requirements of each Service. This procedure would involve ODDR&E personnel fully in the coordination and decision making process, while at the same time ensure the participation of persons responsible to the management of the medical and human resources R&D programs of the three Services.

Recommendation: "It is recommended that interagency coordination [of dental research] activities continue and that, in addition, a Dental Research Coordinating Subgroup has been proposed under the Medical and Human Resources Technology Base Planning Group (see Section 4.6) with representation from the three Services with the objective of coordinating the Army and Navy dental research programs and to assure that these programs are addressing the highest priority dental problems across the three Services. This group should be composed of representatives of the three Surgeons General, the Dental Research Division of AMRDC, and the Dental Health Division of NMRDC. Participation by the Directors of the Dental Research Laboratories should be decided upon after further study." (Page 40)

Response: Concur with the establishment of a Dental Research Coordinating Group, but not as a component of the proposed ODDR&E-based Technology Base Planning Group.

Recommendation: "At least one session of the Joint Medical Research Conference each year should be devoted to the subject of dental research to include a report to the JMRC by the Defense Dental Research Coordinating Subgroup." (Page 41)

Response: We disagree with the proposal to devote one session of the JMRC each year to dental research. The dental R&D programs of the Navy and Army are not large enough to require such intense and frequent scrutiny.

Recommendation: "It is recommended that this area [Arctic Medical Research] be examined further with the objective of formulating a coordinated plan of work addressing established goals." (Page 41)

Response: Concur

Recommendation: "The cost-effectiveness of the currently existing [overseas laboratories] should be challenged through reexamination regularly to ensure that the benefits to be gained continue to warrant the investment. It is recommended that the reexamination be conducted every five years." (Page 42)

Response: Concur



DEPARTMENT OF THE NAVY
OFFICE OF THE ASSISTANT SECRETARY
(RESEARCH AND DEVELOPMENT)
WASHINGTON, D. C. 20350

9 June 1976

137

MEMORANDUM FOR THE DIRECTOR OF DEFENSE RESEARCH AND ENGINEERING

Subj: Draft Final Report of the DDR&E Medical and Human Resources Laboratory Utilization Study; Implementation actions

Ref: (a) ODDR&E memo of 16 April 1976, same subject
(b) ODDR&E memo of 7 May 1976, same subject
(c) Navy Response to subject Report

Encl: (1) Navy Proposed Implementation Actions and Schedule
In Response to: Draft Final Report of the
DDR&E Medical and Human Resources Laboratory
Utilization Study

Reference (a) forwarded subject report and requested a review for accuracy and comments concerning the general and specific conclusions and recommendations. Also requested was a description of implementation actions and schedule for those recommendations with which the Navy agreed.

Reference (b) established a schedule for responding to reference (a). Reference (c) is the Navy Response to subject report, and indicates those recommendations with which the Navy agrees.

This memorandum forwards enclosure (1), which describes implementation actions and schedules for those recommendations with which the Navy concurred.

SAMUEL KOSLOV
SPECIAL ASSISTANT (SCIENCE)

NAVY
PROPOSED IMPLEMENTATION ACTIONS
AND SCHEDULE

IN RESPONSE TO:
DRAFT FINAL REPORT OF THE DDR&E
MEDICAL AND HUMAN RESOURCES
LABORATORY UTILIZATION STUDY

ENCLOSURE (1)

IMPLEMENTATION ACTIONS AND SCHEDULE

This paper presents the proposed implementation actions for those recommendations of the Draft Final Report of the DDR&E Medical and Human Resources Laboratory Utilization Study with which the Navy concurred.

Recommendation: "The budget and program review process, while satisfactory, are "at times excessive". (The Study Group) recommended a reevaluation of these processes." (Page 19)

Implementation: The recommendation made in the Navy LUS II report is cited below from page VI-4:

"Within DOD it is recommended that the office of DDR&E review all on-going studies it has charted and eliminate duplication and redundancy not only between studies but between such studies and regularly and specially scheduled reviews such as budget reviews for the President's Budget (with OMB), apportionment hearings, monthly Joint Medical Research Conference program reviews, Technical Coordinating Papers and Topical Reviews. In addition, future studies should be more explicitly chartered and defined. Scheduling of studies should be done in such a way that all pertinent study efforts which impact on a given issue can be considered prior to decision on that issue."

At the time that the Navy LUS II study was in progress the committee ascertained that a number of other reviews and studies were concurrently in progress, the findings of which although not available should impact on the deliberations and findings of LUS II. The Navy LUS II Study Group expressed its concern at the number and scheduling of these reviews and studies and recommended that DDR&E review its on-going studies for duplication, redundancy, and scheduling. A partial list of on-going reviews and studies as of that time follows:

1. Joint Army-Navy-Air Force Impact Research Panel Study
2. Acceleration, Vibration and Impact Study
3. Tri-Service Panel on EMR Study
4. Aviation Medical Research Study
5. NNMC-USUHS Animal Facility Study
6. Defense Science Board, Summer Study on Technology Base Strategy (Newport)

7. Defense Science Board, Task Force on Training Technology
8. Humanitarian Aspects of Injuries Produced by Modern Weapons Study
9. Topical Review on Human Factors
10. Topical Review on Biological Defense
11. Topical Review on Malaria Research
12. Technical Coordinating Paper revision begun but not completed

It was noted that each of the above reviews and studies were superimposed on the routinely scheduled Navy and DDR&E budget reviews and the monthly meeting of the Joint Medical Research Conference. It was not the intent of the Navy LUS II Study Group to criticize the frequency of intra-Navy reviews, but rather the multitude of DDR&E-imposed reviews.

The Navy will be happy to participate with DDR&E and the other services in a reevaluation of these processes if such action is initiated by DDR&E.

Recommendation: "...recommendations were made for a re-balancing or increase in effort in certain activities of the Navy Health Research Center, the Submarine Medical Research Laboratory..." (Page 19)

Implementation:

- I. Naval Health Research Center. The mission of this activity was modified effective 1 July 74. The change in mission reflects a significant rebalancing of program content as outlined below:

Increased emphasis

Stress medicine; particularly the effects of physical fitness and fatigue on health and performance.

Relationships of psychological stress to illness.

Epidemiology of illness in the fleet.

Infectious diseases in recruit centers and fleet; stress/immunocompetence relationships.

Decreased emphasis

Selection methodology for various enlisted occupations.

Psychiatric screening of a recruits and first enlistment personnel.

Drug and alcohol abuse.

Small group dynamics in relation to psychiatric adjustment.

The above mentioned changes in emphasis have already begun and will continue over the next several years.

- II. Naval Submarine Medical Research Laboratory. Re-balancing of programs at this laboratory will entail decreased R&D on diving medicine and a concomitant increase in submarine medicine and subsurface human factors R&D. Completion of construction (estimated: summer 1978) of the new Environmental Health Effects Laboratory at the Naval Medical Research Institute will enable a phased transfer of diving medicine research to that activity. Plans for the increase in submarine medical research are described under the recommendation relative to that subject.

Recommendation: "This study identified a need to better incorporate these laboratories into the material acquisition and personnel management process and the structure for policy making when such policy affects the human element of the Military Department." (Page 22)

Implementation:

1. Prepare SECNAV Instruction establishing this point as policy.
 - a. Prepare initial draft of Instruction. 1 Jul 1976
 - b. Complete preliminary staffing of Instruction. 15 Aug 1976
 - c. Approval of Instruction. 1 Nov 1976
2. There is a draft OPNAV Instruction on Human Factors Engineering in System Development in the formal comment stage. This Instruction will implement that part of the recommendation that deals with the material acquisition process.
 - a. Preparation of final draft of Instruction. 15 Jul 1976
 - b. Staffing of final draft of Instruction. Complete 1 Oct 1976
 - c. Approval of Instruction. 15 Dec 1976

Recommendation: "The programs of each of the laboratories covered by this study should be reviewed with the objective of identifying that work which should not be funded by Technology Base funds and appropriate funding for that work should be programmed". (Page 23)

and

Recommendation: "It should be established as a matter of principle that these laboratories (i.e. human resources) are technology laboratories, not analyses shops. It should be acknowledged that the rendering of assistance, appropriate data, and recommendations to the personnel policy decision makers is a legitimate and valuable function of the laboratories. And lastly, procedures to provide the resources required to accomplish this function from sources other than the Technology Base should be established. This is being partially accomplished by the Navy but not by the Army and Air Force." (page 24)

Implementation: As recognized in the ODDR&E Draft Report, program review procedures, operating practices, and procedures to provide resources required from non-Technology Base funds are extant in Navy. In response to the concern expressed in these two recommendations in the Draft Report, however, a SECNAV Notice will be issued prior to 1 November 1976 citing this concern and reenforcing the need for continuing attention to and compliance with these established procedures and practices.

Recommendation: "... that a Joint Human Resources Research Conference be established with membership from each of the Military Departments, chaired by an outside consultant and with the Military Assistant for Human Resources, ODDR&E as the Executive Secretary." (Page 24)

Implementation: Appropriate Navy representatives to the proposed Joint Human Resources Research Conference will be appointed by the Navy when the conference is established by OSD.

Recommendation: "The LUS Study discussed at some length the urgent need to modify existing Civil Service practices and regulations insofar as they apply to R&D personnel and especially to those working in the laboratories. (See LUS Appendix E.) In addition to the recommendations made in the LUS, two additional specific recommendations were generated by this study. The first is that longer probationary periods

be authorized for laboratory professionals. Such a change would lengthen the period of service before the employee would attain permanent employee status. The second recommendation suggests that professionals be employed on term contracts with renewal options to be granted at the discretion of the laboratory director." (Page 25)

Implementation: Since the problems leading to this recommendation, and the objectives sought, are equally applicable to each service, DOD is the appropriate office to take implementing action. The Navy will appoint appropriate representatives to participate and assist in any joint effort proposed by DOD.

Recommendation: "A single program planning organization for human resources Technology Base work should be established in each service." (Page 25)

Implementation: The Navy has proposed a program planning organization for human resources Technology Base work, consisting of a Steering Committee and an Advisory Committee, using the NPRDC coordination function to provide detailed input to the committees.

A SECNAV Instruction will be prepared that will address the following:

1. Functions of the committees
2. Membership of the committees
3. Relationships to offices in OPNAV and to ASN(R&D)
4. Reporting procedures.

Schedule

- a. First Draft of Instruction prepared. 16 Jul 1976
- b. Preliminary staffing among agencies most affected completed. 1 Sept 1976
- c. Formal staffing for comments completed. 1 Oct 1976
- d. Coordination of final draft completed. 1 Dec 1976
- e. Approval of Instruction 15 Dec 1976

Recommendation: "The development and maturing of the newly created Naval Medical R&D Command should be continued."
(Page 28)

Implementation: The Command has identified several management objectives which will be addressed in the FY 77-79 timeframe. These fall into the following broad categories:

- a. RDT&E Requirements Documentation
- b. Program Planning
- c. Resources Management (manpower, facilities, and funds)
- d. Program Evaluation
- e. R&D Product Application
- f. Management Information Systems

Specific target dates for completion of individual objectives are cited in the Bureau of Medicine and Surgery's Management by Objectives Plan.

Recommendation: "It is recommended that the Navy increase its emphasis in submarine medicine and in subsurface human factors R&D." (Page 29)

Implementation: As requirements for additional research in submarine medicine and human factors are identified and validated, funding commensurate with the magnitude and priority of the work will be sought and programmed. Actions toward this end are summarized below:

- | | |
|--|--------------|
| I. Technical Working Group (TWG) convened to identify requirements for submarine medicine and subsurface human factors R&D | Nov 75 |
| II. Publication of TWG report | Aug 76 |
| III. Preparation and approval of Operational Requirements | Jul 77 |
| IV. Preparation/review/approval of 5-Year Objectives and Plans | Jan 78 |
| V. Appropriate programming and budgeting | Jan - Sep 78 |

Recommendation: "It is recommended that the Navy prepare a five-year plan for Naval aviation medicine and this plan be coordinated with the Air Force which conducts the major program in this area. The plan should include a detailed review of the future of the NADC Crew Systems Department and the NAMRC Detachment at Michoud, Louisiana." (Page 30)

Implementation:

- I. Requirements Identification
 - a. Review and validation of existing Science and Technology Objectives and Operational Requirements relating to aviation medicine Sep 76
 - b. Conversion of existing Advanced Development Objectives to Operational Requirements and preparation of new Operational Requirements Jan 77
 - c. Approval of new Operational Requirements Mar 77
- II. 5-Year RDT&E Objectives
 - a. Preparation by NMRDC Jun 77
 - b. Promulgation Jul 77
- III. 5-Year RDT&E Plans
 - a. Preparation by laboratories Dec 77
 - (1) Naval Aerospace Medical Research Laboratory and Michoud Detachment
 - (2) Crew Systems Department, Naval Air Development Center
 - (3) National Parachute Test Range
 - (4) Pacific Missile Test Center
 - b. Submission to NMRDC Dec 77
 - c. Coordination with Air Force and Army Mar - Dec 77
 - d. Final modifications and approval Jan 78

Recommendation: "NPRDC should consider the establishment of additional field units collocated with users, for example, in the area of flight training" (Page 30)

Implementation: NPRDC will examine the feasibility of establishing such units and, if indicated in terms of desirability, determine if such establishment is possible within existing personnel ceilings. NPRDC review will be completed prior to 15 December 1976.

Recommendation: "It is recommended that interagency coordination (of dental research) activities continue and that, in addition, a Dental Research Coordinating Subgroup has been proposed under the Medical and Human Resources Technology Base Planning Group (see Section 4.6) with representation from the three Services with the objective of coordinating the Army and Navy dental research programs and to assure that these programs are addressing the highest priority dental problems across the three Services. This group should be composed of representatives of the three Surgeons General, the Dental Research Division of AMRDC, and the Dental Health Division of NMRDC. Participation by the Directors of the Dental Research Laboratories should be decided upon after further study." (Page 40)

Implementation: The Navy concurs with the establishment of a Dental Research Coordinating Group, but not as a component of the proposed ODDR&E - based Technology Base Planning Group. The Navy will, subject to the concurrence of its sister services, take the initiative in convening the first meeting in mid-FY 77.

Recommendation: "It is recommended that this area (Arctic Medical Research) be examined further with the objective of formulating a coordinated plan of work addressing established goals." (Page 41)

Implementation: The Navy is planning a symposium dealing with Arctic biological and medical matters to be held October 1976. The three Armed Services as well as other interested governmental agencies will be invited participants. Current research and long range goals will be addressed. The report of this meeting should be available about February 1977. The Navy feels that the results of this symposium will clarify the most crucial problems that need to be addressed. It is

planned, based on the results of the symposium, to hold a coordination meeting with the Army to arrive at a mutually agreed upon research program for the Army and Navy including site locations at which portions of the program may best be carried out. This should be completed by October 1977.

It should be pointed out that the work at NARL and Fort Wainwright is quite different: Fort Wainwright is primarily involved in human medical research on cold tolerance and on cold weather equipment evaluation and test, whereas the program at NARL is not human oriented, but is a broad program of basic research in Arctic biology. Research at NARL is not specifically oriented to a colony of captured wild Arctic animals but this colony does represent a valuable resource for the conduct of animal research. The basic research program at NARL is oriented specifically toward the study of comparative biological mechanisms involved in bioenergetics, metabolism, energy conservation and energy utilization. It is not feasible to transfer the animal colony in its entirety to Fort Wainwright as some of the animal species are indigenous to the North Slope. Transfer of the research program from NARL would also have the effect of removing the program from the mainstream of naval Arctic research without any significant cost saving since the NARL laboratory would continue to be required for its efforts in geophysics and earth sciences.

At the present time the biological research program at NARL is supported by a research veterinarian, Captain L. Michael Philo, VC, USAR. Captain Philo serves 50% of his time as attending veterinarian at NARL and the other 50% at the U. S. Army Research Institute for Environmental Medicine Detachment, Fort Wainwright. Through this arrangement it has been possible to maintain effective coordination of the NARL biological research program with related programs of the Army.

Recommendation: "The cost effectiveness of the currently existing (overseas laboratories) should be challenged through reexamination regularly to ensure that the benefits to be gained continue to warrant the investment. It is recommended that the reexamination be conducted every five years." (Page 42)

Implementation: The programs and productivity of the Navy's overseas medical research units are reviewed in depth biennially. During the next review, which is scheduled for early 1977, particular attention will be given to the relevancy of on-going and projected R&D and to the potential utility of research findings in military operations.

DEPARTMENT OF THE AIR FORCE
WASHINGTON, D.C. 20330



OFFICE OF THE SECRETARY

28 MAY 1976

MEMORANDUM FOR DIRECTOR OF DEFENSE RESEARCH AND ENGINEERING

SUBJECT: Draft of Medical and Human Resources Laboratory Utilization
Study Final Report

This is in response to your memorandum of April 16, 1976 which requests recommendations concerning the report and implementation of agreed upon actions.

In general we agree with the Air Force program descriptions and recommended improvements expressed in the draft report. However, we disagree with several recommended actions which would increase ODDR&E direct control within the service technology base programs. We are concerned that implementation of those recommended actions would provide little benefit in comparison to the management and laboratory resources expended.

Our specific comments and concerns are provided in the attachment to this memorandum. We look forward to discussing these issues with your staff over the next month.

John Martin
ACTING ASSISTANT SECRETARY
RESEARCH AND DEVELOPMENT

1 Attachment
Air Force Comments on Draft of Medical
& Human Resources Laboratory Utilization
Study Final Report



AIR FORCE COMMENTS ON DRAFT OF
MEDICAL & HUMAN RESOURCES LABORATORY UTILIZATION
STUDY FINAL REPORT

GENERAL COMMENTS

1. The Air Force portion of the report is basically acceptable with the exception of reservations noted in the following paragraphs.
2. The Air Force acknowledges and endorses the concept of interdependency. In fact, considerable progress in formal tri-service agreements has already been made as documented in Chapter 10 of the Air Force Medical and Human Resources Laboratory Utilization Study.
3. The draft report goes into considerable detail as to the impact and philosophy of non-technology base work (systems support, job shops). The resulting categorization of R&D efforts into two neat divisions of technology base and systems support is, in reality, not so well defined. Much of what is considered systems support gives direction, priority and emphasis to on-going technology base efforts, and is in fact advancing the overall technology base of the laboratories.
4. Some of the recommendations in the report mean a step wise expansion of ODDR&E influence in the service R&D programs. The benefits to be gained by layering additional review procedures on an already intensively reviewed area are not substantiated in the draft report. It is inherently disturbing to the Laboratory management process that the medical and human resources laboratories should be treated as special cases, and significantly different from the other laboratories.
5. We do not have the Laboratory management overhead necessary to implement several of these recommended actions. In view of the fact that these are recognized as well managed, productive laboratories, further management overlay is highly questionable.

SPECIFIC COMMENTS

1. Formation of Joint Human Resources Conference, Section 4.2.1.

The commonly used terms human resources, human factors, and human engineering are used extensively in the draft report but there exists no commonly agreed to definition of these terms. The formation of a JHRC should be dependent on commonly agreed definitions of these terms, in order to scope the JHRC in terms of TCP, program element, and functional organization breakouts. The existing Joint Medical Research Conference has, in recent times, shifted to management issues rather than a technical interchange forum, which, in essence, has created a series of monthly topical reviews. It is questionable that the Air Force investment in medical and human resources R&D warrants the extensive management process underway and envisioned by ODDR&E. It is recommended that ODDR&E draft charters for both the JMRC and JHRC so that the

services can come to common agreement on the content, intent, and degree of management oversight necessary to participate.

2. Reimbursement for Non-technology Base Work, Section 4.2.4 and page 24.

The draft report comments extensively on the need to integrate personnel research requirements into the overall human resources technology base planning. The AFHRL currently expends resources against a prioritized list of RPRs. Some RPRs are perishable and must be accomplished on an immediate basis. AFHRL has the authority and direction to integrate the prioritized list of RPRs into the technology base program along with other planning information and requirements. The responsibilities of AF/DP in the generation of requirements are sufficiently clear and recognized. Action is underway to change AFR 80-51 in a manner which will clarify the roles of AF/DP, AFSC, and the user in implementation of products resulting from personnel related RDT&E.

We concur with the general recommendation concerning reimbursement funding for non-technology base studies. However, we disagree with the concept of a Management and Support category within the laboratory program structure. As a management tool, the introduction of a Management and Support category invites administrative and funding adjustments that are not cost effective relative to the level of support rendered. Moreover it introduces the possibility of locking a small cadre of laboratory personnel into a support function at the price of technology base work. Action is being taken to change AFSC Regulation 172-2 to provide more flexibility in obtaining reimbursement of salaries and other direct costs not associated with the exploratory development activity.

3. Interdependency.

There are considerable existing technology base areas for which the Air Force is completely dependent on the other services, or civilian agencies. This is evidenced by the Medical and Biological Sciences TCP wherein the Air Force Biotechnology Program is almost completely contained in one chapter, Hazard Protection and Performance Effectiveness, of the six major program chapters in that document. As examples, the Air Force is totally dependent on other service programs in battle care management, infectious diseases, food and nutrition, and mass casualty effects of nuclear weapons.

These are examples of interdependencies which have realized considerable resource cost avoidances in facilities and research programs. However, the proposed interdependency thrusts appear to change from these current macro arrangements to a work unit level planning comparison in selected technology areas where the services have some commonality of interest. We fully support the concept and formalization of service R&D interdependencies, but are concerned that the present interdependency thrusts are not following a logical path from general agreement to specific research efforts.

We are further concerned that the envisioned interdependencies across DOD Medical and human resources programs do not fully address working interde-

pendencies among these Laboratories and their associated physical science laboratories and product divisions.

The concept proposed in the draft report to have lead service designations for almost all technology areas can only diminish the productivity of the programs that the report seeks to strengthen. The rationale for this concept is not strongly made in the report; it is assumed to be a combination of forced tri-service planning and avoidance of research duplication, which was not a finding of this study or the other review mechanisms now used. We seriously question the cost vs benefit of across-the-board lead service designations in technology base programs.

4. Joint Planning of Medical and Human Resources R&D Within Services.

This recommendation is being done within the Air Force through the investment strategy process of the AFSC Directors of Laboratories. This includes joint planning of all technology base programs in biotechnology, human resources, and life sciences basic research.

5. Medical and Human Resources Technology Base Planning Group.

We do not concur with the formation of such a group. The proposed planning mechanism violates the existing management process for R&D planning and programming.

Specifically:

a. The separate planning process for these Laboratories would subvert the total Air Force investment strategy process. This would in essence, remove medical and human resources laboratory planning from effective control by the AFSC Director of Laboratories, with concomitant impact on the planning and budget cycles of other technology base programs.

b. The single manager concept for all Air Force research, as instituted in AFOSR, would be subject to outside influences which could severely distort its efficiency.

c. Continued efforts to achieve increased interdependencies using existing and proven management techniques are a better option than creating new planning groups and panels.

d. The existing management overlay for these programs is at a minimum. In order to respond to the suggested array of planning panels, the Air Force would have to use senior managers from the Laboratories. This investment in time and travel is not warranted by the conclusions of the study.

6. AFRRI Recommendations.

The Air Force agrees with the substance of the study remarks concerning future requirements for basic research in the biological effects of nuclear weapons. Of the options presented, amalgamation of AFRRI with the Uniformed

Services University of the Health Sciences appears to offer a suitable capability for residual research programs in their area of expertise.

7. Civilian Personnel Policy.

We agree with the concepts presented as offering greater management flexibility, and good for the laboratories. There are questions concerning their appropriateness in terms of federal statutes and regulations. These suggestions have wider application than the medical and human resources laboratories, or the DOD. It is suggested that they be reviewed by the appropriate OSD office.



DEFENSE NUCLEAR AGENCY
WASHINGTON, D.C. 20305

153

828

MAY 4 1976

DDST

APPENDIX O

MEMORANDUM FOR: DIRECTOR OF DEFENSE RESEARCH AND ENGINEERING

SUBJECT: Medical and Human Resources Laboratories Utilization Study

1. I do not concur with the final conclusion and proposed alternatives for the disposition of the Armed Forces Radiobiology Research Institute (AFRRI), as outlined in the draft study, subject as above, forwarded by your memorandum of 16 April. Instead, I recommend strongly that AFRRI should remain an integral subordinate unit of the Defense Nuclear Agency (DNA), immediately responsive to the Service research requirements in accordance with the provisions of its present charter.
2. Closing the laboratory or transferring it to another federal agency is not in the best interest of the Armed Forces. The AFRRI is a unique scientific and technical resource that is highly responsive to Service requirements, including technical consultation and training, in addition to research; and, every indication is that the requirement for the AFRRI as a Department of Defense resource in direct support of missions assigned to DNA will continue.
3. The AFRRI research program is keyed to a wide variety of Service requirements in accordance with the advice and concurrence of the three Surgeons General. Ninety-five percent of its effort is in direct support of Service missions and tasks from OSD/JCS. The strategy of level funding, diversification of research effort and acceptance of reimbursables from other DoD elements that has been followed over the past several years as a means of maintaining AFRRI in a responsive posture has been amply justified. AFRRI is now actively engaged in a long-range program of radiobiology research related to combined combat stresses and collateral damage expected in Theatre nuclear warfare. This will be associated with a constrained reduction of the reimbursable part of the AFRRI program. These projected plans and programs are covered in greater detail in the attached POM FY 1978-82, Minutes of the Medical NWED Long Range Planning Meeting and the Minutes of the Twenty-Fourth Meeting of the AFRRI Board of Governors.



DDST

SUBJECT: Medical and Human Resources Laboratories Utilization Study

4. The proposal to remove AFRRRI from DNA and transfer it to the Uniformed Services University of the Health Sciences (USUHS), is inappropriate and premature. DNA and AFRRRI have established a close liaison with the USUHS, and it is anticipated that the proximity of the two institutions and their common interest in biomedical research will allow the development of extensive collaboration and cooperation between the two facilities. I am sure the OMB and the Congress would not be satisfied with a lesser collaboration. However, AFRRRI support of DNA's long-range requirements will require its continued subordination within and funding by DNA until the DoD Nuclear Weapon Effects requirements for research are fulfilled. The question of the ultimate disposition of AFRRRI, once DNA requirements for NWE are satisfied, as well as its relationship with the USUHS, will be studied by the Board of Governors at an appropriate time.

5. This position has the concurrence of the Surgeons General and the President of the University, Dr. Anthony Curren.

3 Incl
as

WARREN D. JOHNSON
Lieutenant General, USAF
Director

23 April 1976

FY 1978-82 POM

1. (U) Biomedical Effects Research

a. (U) Objectives: To define and evaluate the prompt (i.e., desired) response of combatants to combinations of blast, thermal and radiation effects of nuclear weapons. These data will be used to establish casualty and risk criteria for employment of Theatre nuclear weapons, to predict combat task performance, to assess the survivability and vulnerability of weapon systems, and to develop methods to prevent, delay, and treat the injurious effects of nuclear weapons. To define the low probability of casualties and burdening illness caused by a combination of nuclear irradiation with thermal flash, blast overpressure and debris induced injuries. These data are of great importance toward the creation of better collateral casualty predictions to civilians in the Theatre battle zone. The dual criteria method of targeting (i.e., high probability of desired damage to targets consistent with very low probability of non-damage to non-targets) now required for limited options in nuclear warfare places great value on these improved determinations since the difference of casualty estimates for varying methodologies now in use is very large; factors of 4 to 10 are not unusual. It must be recalled in this respect that much of the presently used methodology is based on results from Hiroshima; i.e., from an unwarned, exposed population unfamiliar with effects of nuclear explosions. These uncertainties were less important for the

employment of high-yield weapons with poor CEP's against urban/ industrial targets than for Theatre targets located in densely populated areas of Central Europe using accurate, low-yield weapons with tailored effects.

b. (U) Recent Accomplishments: Laboratory experiments on trained primates exposed to incapacitating doses of ionizing radiation demonstrated that the degree of impairment of performance is directly related to the type of task as well as the type of radiation. For a given dose of radiation, those tasks requiring physical exertion are more significantly affected than those tasks associated with visual recognition patterns. Early incapacitation data obtained for a radiation environment consisting almost exclusively of high energy neutrons (6-30 MeV with an average energy of approximately 14 MeV) indicated that these high energy neutrons are less effective than gamma rays; this result is not significantly different than that obtained with reactor produced neutrons (average energy 0.8 - 1.0 MeV). Accordingly, biological investigations in radiation environments produced by a pulsed reactor are valid for the assessment of the effects of nuclear weapon radiation environments.

A review of currently accepted radiation casualty criteria--in concert with other nuclear weapon effects--was initiated to clarify the operational significance of immediate, transient, and delayed radiation effects. The preliminary results have identified the need for additional research to define the effects of combined

injury and the need to verify the extrapolation reliability from animal-laboratory results to combat force performance.

Significant progress has occurred in the ability to preserve life supporting tissues that might be used in the treatment of radiation injury. These studies will continue in order to assess the viability of field treatment of radiation casualties.

The effects of electromagnetic pulse (EMP) radiation on larger than rodent model were investigated. No acute injurious effect, appearance of late effect (e.g., genetics or cancers) or adverse effect on behavior was discerned. These data were furnished to agencies responsible for establishing standards for occupational environments. This work has been essential to the conduct of EMP tests of operating communication facilities containing large numbers of civilian personnel.

c. (U) Future Plans: The FY 78-82 program will emphasize an assessment of the importance of delayed radiation effects and of combined injury in causing casualties. A broad multidisciplinary program is required in order to understand how a variety of forces, such as radiation, thermal energy, and other environmental stresses interact individually and in combination with the fundamental processes of living systems to produce various states of ineffectiveness and damage and to determine the precise characteristics of sublethal, burdening doses of whole body and partial body irradiation.

Investigations will be initiated to determine the levels that will cause deleterious effects in 1.0 - 10% and 90 - 99% of a population as contrasted to previous efforts which were limited to determining the level for producing casualties in 50% of a population. These types of criteria are vital in planning the ultimate use of nuclear weapons, especially in a tactical situation, in that they have a direct bearing on the type of weapon that might be employed and where it might be used to assure a desired effect on opposing forces. Group responses at the 1.0 - 10% level, particularly to combined stresses, are very important to collateral damage analyses by assessing the risk to friendly forces and to civilian populations.

An assessment will be made of the underlying causes of radiation induced performance decrement and responses such as nausea, emesis, and fatigue. Based on the results of this effort, data on prolonged incapacitation will be obtained and methods to prevent and ameliorate these effects will be developed.

Studies will be initiated to validate the reliability of extrapolating animal performance to man.

Added emphasis will be placed on determining the impact of nuclear weapon effects on medical planning for Theatre nuclear warfare operations. Data estimating the number and types of casualties and defining clinical evaluation and treatment procedures will be assimilated and disseminated to key headquarters and staff personnel of the various DoD components responsible for medical

planning in formal programs and seminars, assisting and complementing existing training and education in Service schools. This is in response to a direct request from the Surgeons General for technical assistance in improving and expanding knowledge of nuclear weapons effects among medical personnel of the three Services.

Blast biology research will include the verification of the model for predicting the injurious effects of air blast from high explosive detonations under field conditions. New initiations will include the evaluation of the degree of protections from combat injury provided by shelter designs anticipated to be encountered in a Theatre nuclear weapon environment.



DIRECTOR OF DEFENSE RESEARCH AND ENGINEERING
WASHINGTON, D C 20301

160

27 SEP 1976

MEMORANDUM FOR ASSISTANT SECRETARY OF THE ARMY
(RESEARCH AND DEVELOPMENT)

SUBJECT: Medical and Human Resources Laboratory Utilization
Study, Follow-Up Actions

APPENDIX P

The Medical and Human Resources Laboratory Utilization Study has addressed three aspects of the DoD in-house laboratories in this area: (1) the organization, management, and structure of the laboratory complex, (2) the in-house/contract ratio, and (3) the proper size of the laboratory complex.

The Study concluded that these laboratories provide unique technical input to military planning and decision making, and that their manning levels and in-house/contract ratio are appropriate.

The draft report of the Study was forwarded for your review and comment on 16 April 1976. The Army response, dated 25 May 1976, concurred with the major conclusions and recommendations of the report.

The Army also concurred in principle with the majority of the specific recommendations. My staff has met with Army representatives to discuss areas of disagreement. As a result of these discussions, there are several remaining areas of concern in the management area. Attachment 1 provides information concerning these inter-Service and Army issues, the Service position, my recommendations, and necessary action. I request your plans for implementing the actions requiring Army attention be forwarded by 19 November 1976.

One area of special note to the Army is listed on page 2 of Attachment 1, under Inter-Service Issues, LUS Issue column entitled, "Prepare a plan in Navy Aviation Medicine." After reviewing the results of the discussions between my staff and the Services on this topic, I believe that this issue should be elevated to include all Services and limited to the re-examination of the programs of acceleration, vibration, and impact RDT&E. I will address this issue and the actions required in a separate memorandum.



Two additional LUS recommendations warrant separate comment. One recommendation proposed establishment of a single organization within DARCOM as the central focal point for planning and executing Human Resources RDT&E and with Army Staff responsibility within DCSRDA. The Army non-concurred with this recommendation emphasizing the different missions of ARI and HEL and the different program focus. My staff has met with Army representatives and agree that a case, based upon specific problems, can not be made to justify combining the two laboratories. However, I believe there remains grounds for our concern, with regard to the need for a centralized coordination and review structure for ARI, HEL, and PM TRADES to assure an integrated process for planning and implementation of RDT&E in this area, even though you do not share my concern. Therefore, I suggest we keep this issue open and observe the effectiveness of your current program and management for this area over the next year.

Another recommendation is that management of the Biomedical Laboratory (Edgewood Arsenal) be transferred to AMRDC and the Surgeon General vice DARCOM. The Army disagreed with this recommendation stating that the problem had been resolved by agreement between the Surgeon General and the Commander of DARCOM, which redefined responsibilities of each. While we recognize this action was directed toward solving a recognized problem, it is too early to evaluate whether this will prove to be an adequate solution. The Congressional concerns about long term problems related to the use of human volunteers in tests and the more recent problems encountered in testing and qualifying an antidote against chemical agents, at this Laboratory, impress us that management problems continued to exist until very recently. Therefore, I suggest we keep this issue open until there has been an opportunity to evaluate the effectiveness of the recent management changes.

Dr. John L. Allen, Deputy Director (Research and Advanced Technology), will continue to serve as the responsible Deputy in this area with Colonel Stanley C. White, Assistant Director (Environmental and Life Sciences), serving as the action officer. Any action you are pursuing relative to any of these topics should be coordinated closely with the AD(E&LS) and, through him, with the other Services.

s/ Malcolm R. Currie

Malcolm R. Currie

Attachment

MEDICAL AND HUMAN RESOURCES LABORATORY UTILIZATION STUDY

INTER-SERVICE ISSUES

<u>LUS ISSUE</u>	<u>SERVICE POSITION</u>	<u>DDR&E RECOMMENDATION AND ACTION REQUIRED</u>
Initiate Joint Planning of Human Resources and Medicine and Life Sciences R&D (with ODDR&E participation).	Services disagree. Agree to concept of coordinated planning of Human Resources and Medical and Life Sciences. All oppose this concept at ODDR&E level as an encroachment upon the Service prerogatives for managing their programs.	Joint Service planning should be done for defined, bounded, technical areas. (e.g., in areas of human factors, the Memo of Understanding on human factors should be completed.) This will be a continuing area of ODDR&E interest, but we will not play a direct role. Action: 1) The Navy take the lead in completing coordination of the memo of understanding for human factors by 19 November 1976. 2) Form a tri-Service ad hoc committee consisting of two representatives from each Service (one from Medicine and one from Human Resources) to identify other areas for tri-Service coordination and develop appropriate plans to be reported to ODDR&E by 2 May 1977. Report results of initial organizational meeting for this effort by 19 November 1976.
Increase Service interdependency in Human Resources and Medical and Life Sciences R&D.	Navy agrees in concept, but no lead Service should be designated for each area. Army disagrees. AF agrees and is ready to formalize the areas and commitments.	Areas of interdependency should be selected on a case-by-case basis, (e.g., Plan for Use of Computers in Training and Education with Air Force taking the lead). This area will remain an ODDR&E issue of interest. Action: 1) Air Force complete coordination on plan for Use of Computers by 19 November 1976. 2) Services use the above ad hoc committee to develop other interdependency agreements and RDT&E plans for implementation as part of the exercise above.

Attachment
Page 1

MEDICAL AND HUMAN RESOURCES LABORATORY UTILIZATION STUDY

INTER-SERVICE ISSUES (CONTINUED)

<u>LUS ISSUE</u>	<u>SERVICE POSITION</u>	<u>DDR&E RECOMMENDATION AND ACTION REQUIRED</u>
Establish Fort Rucker as Tri-Service Center for Helicopter Medicine and Human Resources R&D.	Army agrees and is initiating implementation actions. AF concurs. Navy agrees for Medical, not Human Resources.	Implement concepts. Recognize special problems in human factors and training areas which must be resolved with issues of joint helio training and joint use simulator design and development for training. Action: Army lead in developing and coordinating a plan by 2 May 1977.
Civil Service changes Longer probationary periods Term contracts Increased salary ceilings	Services concur. DoD's action; Services will support, caution to weigh full impact of change.	Commission of Federal Laboratories (COFL) being asked to address this area on behalf of SR&I career fields. Action: DD(R&AT) meeting with COFL scheduled for October 1976.
Navy and Army establish review systems for overseas laboratories.	Navy and Army concur. Navy will perform the reviews biannually; Army will also establish regular reassessment procedures on at least biannual basis.	Accept Army and Navy response as long as biannual reviews are critical and objective. Will remain ODDR&E area of interest. Action: Army and Navy implementation plan by 19 November 1976.
Joint Human Resources Research Conference.	Army and Navy concur. AF equivocal; request definition of objective.	Establish Joint Human Resources Research Conference, modeled after JMRC. Action: ODDR&E (E&LS) by 1 November 1976.
Prepare a plan in Naval Aviation Medicine, coordinate with Air Force, that will perform a detailed review of the future continued need of operation of the NADC Crew Systems Department and the NAMRL Det. at Michoud, LA.	Navy agrees to undertake a study and is initiating the study in September 1976 with completion in January 1978.	Escalate the planning to inter-Service level; limit study to address all facilities in acceleration, vibration, impact areas. Air Force is asked to take lead in performing and coordinating the study; request study be completed by 1 June 1977.

MEDICAL AND HUMAN RESOURCES LABORATORY UTILIZATION STUDY

ARMY ISSUES

LUS ISSUE

Management of Biomedical Lab
(Edgewood Arsenal).

Place Human Resources in Army
under a single organization under
DARCOM and DCSRDA.

More ARI involvement in materiel
acquisition process.

Appropriate funding for non-R&D work.

SERVICE POSITION:

Army disagrees stating problem has
been resolved by revision of the
agreement between Surgeon General
and Commander of DARCOM.

Army non-concurs; they perceive no
problems with current arrangement.

Army report noted this as a problem.
In later discussions, Army disagreed
stating that problem had been solved
during past 7 months.

Army agrees in principle. No
implementation plan has been received.

DDR&E RECOMMENDATION AND
ACTION REQUIRED

Keep issue open since it is to early to
evaluate effectiveness of revised agreement.

Keep issue open to observe effectiveness of
program and management for one year.

Keep issue open to permit ODDR&E review
of evidence that problem has been solved.
Request documentation of more ARI involve-
ment in materiel acquisition process by
19 November 1976. Action: Army

Phase funding changes to be completed by
FY 1979 POM; submit. Request implementation
plan by 19 November 1976. Action: Army



DIRECTOR OF DEFENSE RESEARCH AND ENGINEERING
WASHINGTON, D. C. 20301

165

8 7 SEP 1976

MEMORANDUM FOR ASSISTANT SECRETARY OF THE NAVY
(RESEARCH AND DEVELOPMENT)

SUBJECT: Medical and Human Resources Laboratory Utilization
Study, Follow-Up Actions

APPENDIX Q

The Medical and Human Resources Laboratory Utilization Study has addressed three aspects of the DoD in-house laboratories in this area: (1) the organization, management, and structure of the laboratory complex, (2) the in-house/contract ratio, and (3) the proper size of the laboratory complex.

The Study concluded that these laboratories provide unique technical input to military planning and decision making, and that their manning levels and in-house/contract ratio are appropriate.

The draft report of the Study was forwarded for your review and comment on 16 April 1976. The Navy responses, dated 3 and 9 June 1976, included your evaluation and proposed actions to the recommendations of the report. The specific proposals for management changes in the Navy laboratory structure, included in your response, are summarized in Attachment 1. My staff has met informally with Navy staff representatives and has reviewed the Navy implementation plan for the recommendations, and I generally concur in the Navy proposed plans of action.

There are several remaining areas of concern regarding management. Attachment 2 provides information concerning these inter-Service and Navy issues, the Service position, my recommendations, and necessary action. I request your plans for implementing the actions requiring Navy attention be forwarded by 19 November 1976.

Three additional LUS recommendations require separate comment. These include:

(1) A plan was requested for Navy Aviation Medicine. After reviewing the results of the discussions between my staff and the Services on this topic, I believe that this issue should be elevated to



include all Services and limited to the re-examination of the programs of acceleration, vibration, and impact RDT&E. I will address this issue and the actions required in a separate memorandum.

(2) The LUS recommended that the Biosciences Research Laboratory, Berkeley, California, be closed or transferred outside the DoD management. The Navy made a counterproposal to retain the laboratory but change its mission by assigning to it the responsibility for conducting all Navy 6.1 and 6.2 R&D environmental quality and occupational safety and health. The Navy has prepared a plan to define the specific role of the laboratory in the new mission. This plan is under review by ODDR&E. This issue will remain open until the review is completed.

(3) The LUS recommended that NPRDC be established as the central planning and coordinating organization for all Navy 6.2 and 6.3A Human Resources R&D. The Navy concurred with the recommendation in principle, but offered a counterproposal to establish a Steering and Advisory Committee for this area of R&D. In this proposal, the NPRDC will be tasked by the Steering and Advisory Committee to collect and disseminate information concerning the program, conduct analyses and technological assessments, and recommend program modifications to the Steering and Advisory Committee. This alternative proposal by the Navy is acceptable. However, effectiveness of this management arrangement will continue to be considered an item of special ODDR&E interest and subject to further discussion based upon results achieved.

Dr. John L. Allen, Deputy Director (Research and Advanced Technology), will continue to serve as the responsible Deputy in this area with Colonel Stanley C. White, Assistant Director (Environmental and Life Sciences), serving as the action officer. Any actions you are pursuing relative to any of these topics should be coordinated closely with the AD(E&LS) and, through him, with the other Services.

s/ Malcolm R. Currie

Malcolm R. Currie

Attachments

Management Changes Agreed Upon for the
Navy Laboratory Structure

1. Close the medical field lab at Camp Lejeune and transfer work to other laboratories.
2. Consolidate the Navy Toxicology Unit at the Naval Medical Research Institute with a similar unit at the USAF 6570th Aerospace Medical Research Laboratory at Wright-Patterson AFB, Ohio.
3. Reassess the DoD need and content of the Dental R&D program.
4. Include NMRDC and NPRDC in the planning of the contract R&D program conducted by ONR in Medicine and Human Resources.
5. Improve the Medical and Human Resources R&D laboratories input into the materiel acquisition programs.

MEDICAL AND HUMAN RESOURCES LABORATORY UTILIZATION STUDY

LUS ISSUE.

Initiate Joint Planning of Human Resources and Medicine and Life Sciences R&D (with ODDR&E participation).

SERVICE POSITION

Services disagree. Agree to concept of coordinated planning of Human Resources and Medical and Life Sciences. All oppose this concept at ODDR&E level as an encroachment upon the Service prerogatives for managing their programs.

DDR&E RECOMMENDATION AND ACTION REQUIRED

Joint Service planning should be done for defined, bounded, technical areas. (e.g., in areas of human factors, the Memo of Understanding on human factors should be completed.) This will be a continuing area of ODDR&E interest, but we will not play a direct role. Action: 1) The Navy take the lead in completing coordination of the memo of understanding for human factors by 19 November 1976. 2) Form a tri-Service ad hoc committee consisting of two representatives from each Service (one from Medicine and one from Human Resources) to identify other areas for tri-Service coordination and develop appropriate plans to be reported to ODDR&E by 2 May 1977. Report results of initial organizational meeting for this effort by 19 November 1976.

Increase Service interdependency in Human Resources and Medical and Life Sciences R&D.

Navy agrees in concept, but no lead Service should be designated for each area. Army disagrees. AF agrees and is ready to formalize the areas and commitments.

Areas of interdependency should be selected on a case-by-case basis. (e.g., Plan for Use of Computers in Training and Education with Air Force taking the lead). This area will remain an ODDR&E issue of interest. Action:

- 1) Air Force complete coordination on plan for Use of Computers by 19 November 1976.
- 2) Services use the above ad hoc committee to develop other interdependency agreements and RDT&E plans for implementation as part of the exercise above.

MEDICAL AND HUMAN RESOURCES LABORATORY UTILIZATION STUDY

INTER-SERVICE ISSUES (CONTINUED)

<u>LUS ISSUE</u>	<u>SERVICE POSITION</u>	<u>DDR&E RECOMMENDATION AND ACTION REQUIRED</u>
Establish Fort Rucker as Tri-Service Center for Helicopter Medicine and Human Resources R&D.	Army agrees and is initiating implementation actions. AF concurs. Navy agrees for Medical, not Human Resources.	Implement concepts. Recognize special problems in human factors and training areas which must be resolved with issues of joint helio training and joint use simulator design and development for training. Action: Army lead in developing and coordinating a plan by 2 May 1977.
Civil Service changes Longer probationary periods Term contracts Increased salary ceilings	Services concur. DoD's action; Services will support, caution to weigh full impact of change.	Commission of Federal Laboratories (COFL) being asked to address this area on behalf of SR&T career fields. Action: DD(R&AT) meeting with COFL scheduled for October 1976.
Navy and Army establish review systems for overseas laboratories.	Navy and Army concur. Navy will perform the reviews biannually; Army will also establish regular reassessment procedures on at least biannual basis.	Accept Army and Navy response as long as biannual reviews are critical and objective. Will remain ODDR&E area of interest. Action: Army and Navy implementation plan by 19 November 1976.
Joint Human Resources Research Conference.	Army and Navy concur. AF equivocal; request definition of objective.	Establish Joint Human Resources Research Conference, modeled after JMRC. Action: ODDR&E (E&LS) by 1 November 1976.
Prepare a plan in Naval Aviation Medicine, coordinate with Air Force, that will perform a detailed review of the future continued need of operation of the NADC Crew Systems Department and the NAMRL Det. at Michoud, LA.	Navy agrees to undertake a study and is initiating the study in September 1976 with completion in January 1978.	Escalate the planning to inter-Service level; limit study to address all facilities in acceleration, vibration, impact areas. Air Force is asked to take lead in performing and coordinating the study; request study be completed by 1 June 1977.

MEDICAL AND HUMAN RESOURCES LABORATORY UTILIZATION STUDY

NAVY ISSUES

LUS ISSUE

Reassess Dental R&D program.

Navy concurs; proposes A, N study of needs with a proposed R&D plan by mid-FY 77.

DDR&E RECOMMENDATION AND ACTION REQUIRED

Dental caries research was examined as a FY 77 apportionment issue. Agree to Navy plan to review other dental R&D. Action: Navy and Army, with Navy assuming lead.

SERVICE POSITION

Improve the Medical and Human Resources R&D laboratories input into the materiel acquisition programs.

Navy concurs; publishing SecNav Instruction to establish this as policy and OPNAV Instruction to clarify human factors engineering in Systems Development.

Concu. in proposed action. Desire to review these documents to see if they resolve this issue. Will remain an area of ODDR&E interest. Action: Navy; ODDR&E review of documents.

Close or transfer the Biosciences Research Laboratory outside the DoD management.

Navy disagrees. Proposes to make lab the 6.1 and 6.2 lab for Environmental Quality and Occupational Safety and Health R&D. Navy is preparing a plan to reflect this, available to ODDR&E by 1 August 1976.

Hold final DDR&E recommendation on Navy proposal until the Navy plan for future use is examined. Action: ODDR&E complete review of mission by 3 September 1976.



DIRECTOR OF DEFENSE RESEARCH AND ENGINEERING
WASHINGTON, D C 20301

171

27 SEP 1976

MEMORANDUM FOR ASSISTANT SECRETARY OF THE AIR FORCE
(RESEARCH AND DEVELOPMENT)

SUBJECT: Medical and Human Resources Laboratory Utilization
Study, Follow-Up Actions

APPENDIX R

The Medical and Human Resources Laboratory Utilization Study has addressed three aspects of the DoD in-house laboratories in this area: (1) the organization, management, and structure of the laboratory complex, (2) the in-house/contract ratio, and (3) the proper size of the laboratory complex.

The Study concluded that these laboratories provide unique technical input to military planning and decision making, and that their manning levels and in-house/contract ratio are appropriate.

The draft report of the Study was forwarded for your review and comment on 16 April 1976. The Air Force response, dated 28 May 1976, expressed agreement with major inter-Service conclusions and recommendations, and general agreement with Air Force program descriptions and recommended improvements. However, disagreement was expressed with regard to several recommendations which would increase ODDR&E direct control of Technology Base programs. Although my staff has met with Air Force staff in an attempt to understand and resolve major points of disagreement, there are several remaining areas of concern regarding laboratory management. Attachment 1 provides information concerning the inter-Service and Air Force issues, the Service position, my recommendation, and necessary action in areas of disagreement. I would like to receive by 19 November, your plans for implementation of these actions.

One area of special note to the Air Force is listed on page 2 of Attachment 1, under Inter-Service Issues, LUS Issue column entitled, "Prepare a plan in Navy Aviation Medicine." After reviewing the results of the discussions between my staff and the Services on this topic, I believe that this issue should be elevated to include all Services and limited to the re-examination of the programs of acceleration, vibration,



and impact RDT&E. I will address this issue and the actions required in a separate memorandum.

An additional ODDR&E recommendation requires separate comment. This is the specific issue raised with the Air Force with regard to the need to revise AFR 80-51 to make Requirements for Personnel Research one input to the overall planning and programming process of AFHRL and providing the authority within AFHRL to develop their Technology Base program using all planning information. We recognize that the Air Force is currently revising the regulation. A draft of the proposed revision has been reviewed by my staff and is judged satisfactory with regard to meeting the above goals.

Dr. John L. Allen, Deputy Director (Research and Advanced Technology), will continue to serve as the responsible Deputy in this area with Colonel Stanley C. White, Assistant Director (Environmental and Life Sciences), serving as the action officer. Any actions you are pursuing relative to any of these topics should be coordinated closely with the AD(E&LS) and, through him, with the other Services.

s/ Malcolm R. Currie

Malcolm R. Currie

Attachment

MEDICAL AND HUMAN RESOURCES LABORATORY UTILIZATION STUDY

INTER-SERVICE ISSUES

LUS ISSUE

Initiate Joint Planning of Human Resources and Medicine and Life Sciences R&D (with ODDR&E participation).

SERVICE POSITION

Services disagree. Agree to concept of coordinated planning of Human Resources and Medical and Life Sciences. All oppose this concept at ODDR&E level as an encroachment upon the Service prerogatives for managing their programs.

DDR&E RECOMMENDATION AND ACTION REQUIRED

Joint Service planning should be done for defined, bounded, technical areas. (e.g., in areas of human factors, the Memo of Understanding on human factors should be completed.) This will be a continuing area of ODDR&E interest, but we will not play a direct role. Action: 1) The Navy take the lead in completing coordination of the memo of understanding for human factors by 19 November 1976. 2) Form a tri-Service ad hoc committee consisting of two representatives from each Service (one from Medicine and one from Human Resources) to identify other areas for tri-Service coordination and develop appropriate plans to be reported to ODDR&E by 2 May 1977. Report results of initial organizational meeting for this effort by 19 November 1976.

Increase Service interdependency in Human Resources and Medical and Life Sciences R&D.

Navy agrees in concept, but no lead Service should be designated for each area. Army disagrees. AF agrees and is ready to formalize the areas and commitments.

Areas of interdependency should be selected on a case-by-case basis, (e.g., Plan for Use of Computers in Training and Education with Air Force taking the lead). This area will remain an ODDR&E issue of interest. Action:

- 1) Air Force complete coordination on Plan for Use of Computers by 19 November 1976.
- 2) Services use the above ad hoc committee to develop other interdependency agreements and RDT&E plans for implementation as part of the exercise above.

Attachment
Page 1

MEDICAL AND HUMAN RESOURCES LABORATORY UTILIZATION STUDY

INTER-SERVICE ISSUES (CONTINUED)

LUS ISSUE

Establish Fort Rucker as Tri-Service Center for Helicopter Medicine and Human Resources R&D.

Civil Service changes
Longer probationary periods
Term contracts
Increased salary ceilings

Navy and Army establish review systems for overseas laboratories.

Joint Human Resources Research Conference.

Prepare a plan in Naval Aviation Medicine, coordinate with Air Force, that will perform a detailed review of the future continued need of operation of the NADC Crew Systems Department and the NAMRL Det. at Michoud, LA.

SERVICE POSITION

Army agrees and is initiating implementation actions. AF concurs. Navy agrees for Medical, not Human Resources.

Services concur. DoD's action; Services will support, caution to weigh full impact of change.

Navy and Army concur. Navy will perform the reviews biannually; Army will also establish regular reassessment procedures on at least biannual basis.

Army and Navy concur. AF equivocal; request definition of objective.

Navy agrees to undertake a study and is initiating the study in September 1976 with completion in January 1978.

DDR&E RECOMMENDATION AND ACTION REQUIRED

Implement concepts. Recognize special problems in human factors and training areas which must be resolved with issues of joint helio training and joint use simulator design and development for training. Action: Army lead in developing and coordinating a plan by 2 May 1977.

Commission of Federal Laboratories (COFL) being asked to address this area on behalf of SR&T career fields. Action: DD(R&AT) meeting with COFL scheduled for October 1976.

Accept Army and Navy response as long as biannual reviews are critical and objective. Will remain ODDR&E area of interest. Action: Army and Navy implementation plan by 19 November 1976.

Establish Joint Human Resources Research Conference, modeled after JMRC. Action: ODDR&E (E&LS) by 1 November 1976.

Escalate the planning to inter-Service level; limit study to address all facilities in acceleration, vibration, impact areas. Air Force is asked to take lead in performing and coordinating the study; request study be completed by 1 June 1977.

MEDICAL AND HUMAN RESOURCES LABORATORY UTILIZATION STUDY

AIR FORCE ISSUES

LUS ISSUE

Revise AFR 80-51

- Make Requirements for Personnel Research part of overall planning process of AFHRL not driving programmatic force.
- Assign AFHRL authority to develop Tech Base program (subject to normal review and approval procedures) based on all planning information.
- Fund requirements for analysis or other non-Tech Base efforts on a cost reimbursable basis.

Appropriate funding for non-R&D work.

SERVICE POSITION

Revision underway.

DDR&E RECOMMENDATION AND ACTION REQUIRED

Present draft of proposed revision satisfactory. ODDR&E review of final draft before publication. Action: Air Force

Air Force agrees in principle. Air Force is revising AFSCR 172-2. No implementation plan has been received.

Phase funding changes to be completed by FY 1979 POM submit. Request implementation plan by 19 November 1976. Action: Air Force

BIBLIOGRAPHY

- Reference 1 - Final Report: The DoD Laboratory Utilization Study, Office of the Director of Defense Research and Engineering, Allen, John L.; Grantham, Rodney E.; and Nichols, Donald B., April 28, 1975
- Reference 2 - Report of Working Group to Study Human Resources Research Laboratories (Army), March 1975
- Reference 3 - Medical and Human Resources Laboratories Utilization Study: Report of US Army Subcommittee on Medical Research Laboratories, March 1975
- Reference 4 - US Navy Medical and Human Resources Laboratory Utilization Study, Mr. Bruno Augenstein, Chairman, submitted to Assistant Secretary of the Navy (R&D), May 9, 1975
- Reference 5 - Medical and Human Resources Laboratory Utilization Study, Air Force Systems Command, March 1975