

AD-A039 610

NAVAL RESEARCH LAB WASHINGTON D C  
A 100 J, 40 NSEC Q-SWITCHED ND/GLASS LASER.(U)  
FEB 77 J R GREIG, R E PECHACEK  
NRL-MR-3461

F/G 20/5

UNCLASSIFIED

NL

1 of 1  
ADA039610



END

DATE  
FILMED  
6-77

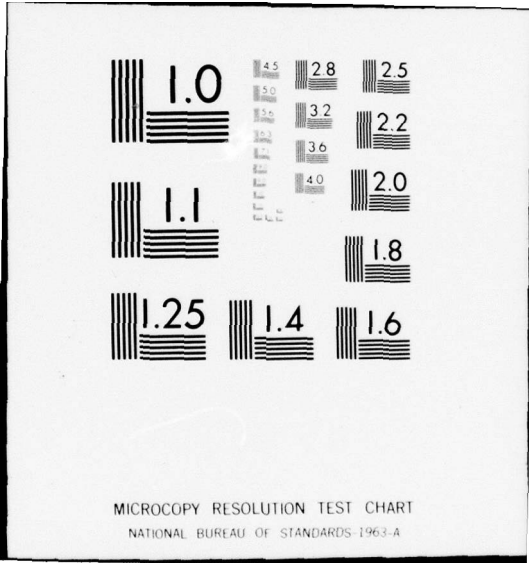

NRL Memorandum Report 3461

# A 100 J, 40 nsec Q-Switched Nd /Glass Laser

J. R. GREIG AND R. E. PECHACEK

*Experimental Plasma Physics  
Plasma Physics Division*

12  
NW

ADA 039610

February 1977

DDC  
RECEIVED  
MAY 19 1977  
C



NAVAL RESEARCH LABORATORY  
Washington, D.C.

AD No. [ ]  
DDC FILE COPY

REPORT DOCUMENTATION PAGE		READ INSTRUCTIONS BEFORE COMPLETING FORM
1. REPORT NUMBER NRL Memorandum Report 3461 ✓	2. GOVT ACCESSION NO.	3. RECIPIENT'S CATALOG NUMBER
4. TITLE (and Subtitle) A 100 J, 40 nsec Q-SWITCHED Nd/GLASS LASER	5. TYPE OF REPORT & PERIOD COVERED Final report, November 1974 - December 1976,	6. PERFORMING ORG. REPORT NUMBER
7. AUTHOR(s) J.R. Greig and R.E. Pechacek	8. CONTRACT OR GRANT NUMBER(s)	
9. PERFORMING ORGANIZATION NAME AND ADDRESS Naval Research Laboratory Washington, D.C. 20375	10. PROGRAM ELEMENT, PROJECT, TASK AREA & WORK UNIT NUMBERS NRL Problem H02-28C Project RR 011-09-41	
11. CONTROLLING OFFICE NAME AND ADDRESS Office of Naval Research Arlington, Virginia 22217	12. REPORT DATE February 1977	
14. MONITORING AGENCY NAME & ADDRESS (if different from Controlling Office) 1248p.	13. NUMBER OF PAGES 48	15. SECURITY CLASS. (of this report) UNCLASSIFIED
16. DISTRIBUTION STATEMENT (of this Report) Approved for public release; distribution unlimited. 14/NRL-MR-3461	15a. DECLASSIFICATION/DOWNGRADING SCHEDULE	
17. DISTRIBUTION STATEMENT (of the abstract entered in Block 20, if different from Report) 16/RR0110941		
18. SUPPLEMENTARY NOTES		
19. KEY WORDS (Continue on reverse side if necessary and identify by block number) Laser Nd/glass High-power APPROXIMATELY 0.0003 MICROMETER MICROSEC.		
20. ABSTRACT (Continue on reverse side if necessary and identify by block number) This report describes the characteristics of a high power Nd/glass laser presently in operation at the Naval Research Laboratory. The laser will produce 100 J of 1.06 μm radiation in a 40 nsec pulse, or in two pulses each of which is 40 nsec wide and separated by 300 nsec to 5 μsec. The divergence of the laser beam is ~ 3 × 10 <sup>-4</sup> radian so that power densities in excess of 10 <sup>13</sup> watts/cm <sup>2</sup> can be achieved. This Nd/glass laser, is not "state of the art" rather it is conservatively rated to provide reliable operation over long periods, with minimum maintenance.		50 CM 10 TO THE 13th POWER

DD FORM 1 JAN 73 1473

EDITION OF 1 NOV 65 IS OBSOLETE  
S/N 0102-014-6601

SECURITY CLASSIFICATION OF THIS PAGE (When Data Entered)

251950

LB

CONTENTS

I Introduction . . . . . 1

II General Description . . . . . 2

II i) The Optical Train . . . . . 2

II ii) The Electrical Block Diagram . . . . . 4

II iii) Mode of Operation and Typical Operating Conditions . . . . . 5

III Optical Component Specifications and Detail . . . . . 8

III i) The Optical Bench . . . . . 9

III ii) The Glass Laser Rods . . . . . 9

III iii) The Laser Heads . . . . . 10

III iv) The Retro Prism and oscillator output mirror . . . . . 11

III v) The Pockels Cells and Polarizers . . . . . 12

III vi) The Beam expanders . . . . . 13

III vii) The Calorimeters . . . . . 13

IV Electrical Detail and Circuit Diagrams . . . . . 14

IV i) The Charging and Safety Interlock Circuits . . . . . 14

IV ii) The Laser firing circuits . . . . . 17

V Acknowledgement . . . . . 21

SEARCHED	INDEXED
SERIALIZED	FILED
JUL 19 1950	
FBI - MEMPHIS	
BY	DATE
DISTRIBUTION/AVAILABILITY CODES	
Dist.	AVAIL. and/or SPECIAL

PRECEDING PAGE BLANK-NOT FILMED

1029408

### A 100 J, 40 nsec Q-SWITCHED Nd/GLASS LASER

#### I. Introduction:

When Plasma Physics Division wanted a 100J Nd/glass laser for use on the Laser induced Z-pinch experiment, an obvious starting point was the collection of C. G. E. laser components which were becoming surplus as development proceeded on the NRL Glass Laser Facility (see for example NRL Memo Report 3315, 1976). In 1971 the complete C. G. E. laser oscillator became available and by continuing to use C. G. E. style optical mounts and Laser Heads, the new Nd/glass laser was developed to be as much as possible compatible with the NRL Glass Laser.

From the beginning then, the 100J, 40nsec Nd/glass laser has relied heavily on C. G. E. laser components. At first the oscillator was the complete C. G. E. rotating prism Q-switched oscillator. Two beam expanders and two laser amplifier heads were purchased from C. G. E. to give the capability of delivering a 100J laser pulse. The glass rods were chosen in accordance with experience gained on the NRL Glass Laser; they are ED-2 glass supplied by Owens-Illinois. All the electrical systems required to charge and fire the laser were designed and built at NRL.

Subsequently the laser has been modified so that i) the oscillator is Q-switched with a Pockels cell and ii) a second Pockels cell between the amplifiers and the oscillator output mirror prevents pre-lasing in the cavity formed between this mirror and the target.

The firing pulse circuitry is designed so that both a prepulse and a giant pulse are produced by the same laser. This is done by simply double pulsing the Pockels cells.

Note: Manuscript submitted February 11, 1977.

Presently this Nd/glass Laser is situated in Room 147, Bldg. 101 with the control circuitry in Room 147A. Enclosed optical paths allow the laser beam to be directed into two different laboratories, Room 145 and Room 159. Each of these rooms contains a remote control station from which the laser can be operated.

## II. General Description:

This 100J, 40nsec Nd/glass laser consists of a Q-switched oscillator and two amplifiers. Each of these three units is of the glass rod type and is optically pumped by one or more helical flash lamps which surround the rod. Each rod is water cooled by a separate cooling circuit.

The oscillator is Q-switched using a Pockels cell and polarizers, and is polarized in the horizontal plane.

### II.i) The Optical Train:

The optical train for the Nd/glass laser is shown schematically in figure 1. Items 1-7 constitute the laser oscillator. It produces a beam of  $1.06\mu\text{m}$  radiation, 12-14mm diameter containing 2-3J in a pulse  $\sim$  40 nsec wide at half maximum intensity. The oscillator can also produce a prepulse which then shares the total energy with the main pulse.

Item (1) is a  $90^\circ$  retro-prism and is the total reflector at the rear of the oscillator cavity. Item (2) is the neodymium doped glass rod with end faces at  $6^\circ$  to the rod axis. The first aperture stop, (3), is a fixed aperture of 14mm diameter. There is a second off-axis aperture in item (3) which allows the weak beam reflected from the face of the oscillator rod (2) to reach the fast diode, (9). This diode is used to monitor the shape of the pulse delivered by the oscillator.

Radiation in the oscillator cavity is polarized in the horizontal

plane by the double plate polarizer, (4). Item (6) is a fast Pockels cell and (5) is a variable aperture stop which is used to limit the total energy given out by the oscillator at high optical pumping. Item (7) is the partially reflecting output mirror of the oscillator cavity. The second diode, (8), is a slow diode and is used to monitor fluorescence radiation at  $1.06\mu\text{m}$  in the oscillator rod. The total energy given out by the oscillator is monitored by the calorimeter, (10).

The second Pockels cell, (11), and the second double plate polarizer, (12), make up the optical isolator. Spontaneous emission from the amplifier rods reflected at the oscillator output mirror, (7), is rejected by this isolator and so is not amplified.

The first beam expander, (13), expands the oscillator output beam by  $\sqrt{2}$  so that it almost fills the first amplifier rod, (14). Both the first amplifier rod, (14), and the second amplifier rod, (17), have end faces at  $6^\circ$  to their cylindrical axes as indicated. A second beam expander, (15), expands the output from the first amplifier, (14), by  $\sqrt{2}$  so that it also almost fills the second amplifier. The variable aperture stop, (16), has been set to 30mm to stop damage occurring at the edge of the output face of the second amplifier (see Section III ii).

Item (18) is a glass plate  $\sim 4.5\text{mm}$  thick which reflects  $\sim 5\%$  of the laser beam into a calorimeter, (19). This calorimeter monitors the total laser output energy. The shape of the output pulse is monitored by a second fast diode, (21) which observes scattered light from the glass plate, (18).

This diode is necessary because the amplification of the prepulse

is much greater than that of the main pulse. Thus typically an almost imperceptible (compared to the noise) prepulse as seen on the fast diode, (9), will become a prepulse containing  $\sim 10\%$  of the total energy as seen at the second fast diode, (21).

Finally at the output end of the laser is a variable aperture stop, (20). This aperture is set at 32mm and serves to define the beam position and to stop any stray light.

#### II.ii) The Electrical Block Diagram:

The essential components of the electrical circuits for both charging and firing the Nd/glass laser are shown schematically in figure 2. The three laser heads, the oscillator head, the first amplifier head, and the second amplifier head, are shown spaced out along the optical axis of the laser. Between the oscillator head and the first amplifier head, there are the two Pockels cells, PC1 and PC2.

The oscillator head contains a single helical flash lamp which is connected to one capacitor module, C1. The first amplifier has two flash lamps and two capacitor modules, C2 and C3. The second amplifier has four flash lamps and is connected to four capacitor modules, C4  $\rightarrow$  C7. The capacitor module C1 is charged/dumped through the connection A'A. The two modules C2 and C3 are charged/dumped through connection B'B. Similarly the four modules C4-C7 are charged/dumped through the connection C'C. In this way each head can be operated separately and each head can be charged to a different charging voltage even though the supply voltage is the same for all of them.

To fire the flash lamps a common trigger pulse is sent through parallel cables from D' to each D separately.

The two Pockels cells PC1 and PC2 are connected in series with a 50 nsec cable-length delay between them ( $\sim 10m$ ). To close the optical switches i.e. to prevent lasing action, a slow bias pulse is applied to both Pockels cells. Then to open the optical switches, i.e. to allow laser action, a fast gating pulse of opposite polarity and equal magnitude is sent through the two cells. This fast pulse ends in the 50 $\Omega$  termination to which PC2 is connected.

Safety with this laser is ensured by the interlock circuit shown in figure 2. The interlock circuit controls the slow timer and prevents the capacitor modules from being activated unless all interlocks are in the safe position. Also, if during the charging cycle any interlock circuit is broken, the charging cycle is immediately interrupted and all capacitor modules are grounded. This interlock circuit contains both the laser protection interlocks on, for instance, the rod cooling system, and personnel safety interlocks on doors, etc. Furthermore there is a two level system of audio and visual warning devices, which signify first that electrical power has been applied to the laser system, and at the second level that the laser has actually been activated, i.e. the capacitor modules are being charged.

As with most laser systems this laser must be considered dangerous whenever the capacitor modules are charged even if not all full charge!

#### II. iii) Mode of Operation and Typical Operating Conditions:

Before the capacitor modules which energize the flash lamps can be charged, the interlock circuit must register in the safe position. This requires i) the cooling water is flowing adequately through each laser head, ii) the safety interlock at the capacitor area must be closed and

the doors to the laser room closed, and iii) the external interlocks (Dumping buttons) in the control rooms of the two laboratories into which the laser can be fired must be in the "safe" position.

With these conditions met, the slow timing unit (figure 2) can be activated and the charging cycle begins. The first step in this cycle is to remove the shorting connection from each group of capacitor modules. Then high voltage is applied to the trigger pulse generator (22 kV) and the flash lamp capacitor modules (rising slowly to 20 kV). The three groups of flash lamp capacitor modules, the oscillator, first, and second amplifiers, each have their own voltage measuring circuit as indicated in figure 2, and disconnect from the charging supply when they reach their preset voltage.

The oscillator will lase at any voltage greater than  $\sim 10$  kV and is usually operated between 13 and 14 kV. The figures quoted here are for the optical train shown in figure 1 i.e. with Pockels cells and polarizers in place. Without these items normal mode lasing occurs at  $< 9.0$  kV. Normal mode lasing (non-Q-switched) begins after  $\sim 250\mu\text{sec}$  of optical pumping with the flash capacitors charged to  $\sim 10.5$  kV, and after  $\sim 160\mu\text{sec}$  with the capacitors charged to  $\sim 13$  kV (Figures 3 and 4). The Q-switched pulse is usually extracted after  $\sim 300\mu\text{sec}$  of optical pumping from a capacitor charge of  $\sim 13$  kV. The amplifiers show zero gain around 5 to 7 kV and are also usually operated at 13 kV. Under these conditions the oscillator puts out 2-3J in the Q-switched pulse, the gain in the first amplifier is  $\sim 8$ , and the gain in the second amplifier is  $\sim 4$ . The actual laser output beam energy after passage through the beam splitter (18) in figure 1, can then be in excess of

100 J.

To prevent normal mode lasing in the oscillator, a slow bias pulse (figure 2) is applied to the Pockels cells at the same time that the flash lamps are fired. This is a slow rising negative pulse (figure 5) with amplitude  $\sim 3.5$  kV which is the  $\lambda/4$  voltage for these Pockels cells. In most other circumstances Pockels cells are closed using a d.c. bias voltage and such a system was initially used on this laser. However the two Pockels cells (Lasermetrics Model 1073) failed after 90 hours and 130 hours of operation at  $\sim 3.5$  kV. Upon replacing the Pockels cells, Lasermetrics withdrew their warranty for d.c. operation and so the slow bias pulse system was installed. In the year since installation of the slow bias pulse, over 1000 laser shots have been fired with, so far, no sign of damage on the Pockels cells.

To effect Q-switching in the oscillator cavity and allow the generation of a giant laser pulse, a  $\lambda/4$  gating pulse is sent through the Pockels cells from the gating pulse generator (figure 2). This pulse is a fast rising, rectangular pulse of  $\sim 3.5$  kV (figure 6a) and width  $\sim 300$  nsec. To lase within this 300 nsec gate the oscillator capacitor module must be charged to  $\geq 11.5$  kV. For a charge of 13 kV the growth time of the giant pulse is  $\sim 150$  nsec. In both cases the oscillator has to be optically pumped for  $\sim 300\mu\text{sec}$  before the Pockels cells are opened.

A prepulse can be added to the giant pulse oscillator output by sending another  $\sim 3.5$  kV, rectangular pulse through the Pockels cells shortly before the 300 nsec gating pulse just described. If the first Pockels cell pulse is only  $\sim 150$  nsec wide the oscillator output does

not have time to grow to a giant pulse. The very small ( $< 200\text{m J}$ ) prepulse so produced is more highly amplified in the amplifiers than the giant pulse and appears at the laser output with 10 or more percent of the total output energy. With this arrangement for producing a laser prepulse the relative size of the prepulse is controlled by the voltage to which the capacitor module driving the oscillator flash lamp is charged. Over the range 13 kV to 14 kV it varies from zero to  $\sim 50\%$  depending on the state of alignment of the oscillator and the cleanliness of its internal surfaces. [The latter are but slow variations.] Both fast pulses and the slow bias pulse are fed to the Pockels cells in series through a single  $50\Omega$  cable. Having passed through the second Pockels cell, the fast pulses terminate in a  $50\Omega$  load which is capacitively coupled to the cable to avoid shorting the slow bias pulse.

A set of data representing a typical laser shot is shown in figure 7. The burn pattern was recorded by placing a piece of exposed (and developed) photographic paper in the beam approximately 6m away from the laser output aperture. Typically the divergence of the laser beam at this energy ( $\sim 100\text{ J}$ ) is  $\sim 3 \times 10^{-4}$  radian. Therefore when focussed with a 100cm focal length lens the power density is  $\sim 10^{12}$  watts/cm<sup>2</sup> and with a 10cm focal length lens  $\sim 10^{14}$  watts/cm<sup>2</sup>.

### III. Optical Component Specifications and Detail:

The laser described in this report is not unique and does not attempt to extend laser technology in any way. However for the benefit of those wishing to use the facility or any newcomer to the field wishing to duplicate the system we include the following specifications of

the components used.

III. i) The Optical Bench:

The optical bench used for this Nd/glass laser is a commercially available re-inforced concrete beam. It is 15 feet long (4.5m) by 8 inches wide (20cm) by 12 inches deep (30cm) and is manufactured by York Lintel and Cast Stone, Inc. of York, Pa. All the optical components of the laser are attached to this optical bench which has threaded holes in its top side (Figure 8.)

This hole configuration is the same as used by C. G. E. and allows us to use their standard optical mount. It is also used in N. R. L. Glass Laser Facility.

The optical bench is supported at each end by a concrete pedestal. The pedestal at the oscillator end of the bench has a sliding contact between itself and the optical bench and the pedestal at the output end of the optical bench as a fixed point contact on one side of the optical bench and a sliding contact on the other. The three contacts are arranged to give a kinematic three point suspension.

This optical bench and mounting pedestals have been found to be very satisfactory, with the laser remaining in stable alignment for many months.

III. ii) The glass laser rods:

All three glass rods used in this laser are Owens-Illinois ED-2 laser glass. This is a lithium aluminum silicate glass, doped 3.1 wt.% with neodymium. Its most notable qualities are high efficiency, high damage threshold, and resistance to solarization. Table 1 contains most of the physical properties of ED-2 glass which are relevant to its use

as a laser glass. These values are taken directly from the Owens-Illinois publications.

The damage threshold of  $20\text{J}/\text{cm}^2$  for these glass rods is a conservative level below which maintenance free operation can be expected over long periods with only the minimum attention to cleaning the glass surface. ED-2 glass has been known to operate successfully at much higher energy densities ( $\sim 100\text{J}/\text{cm}^2$ ) so the bulk damage threshold is certainly very high. However at energy densities above  $20\text{J}/\text{cm}^2$ , surface contamination becomes a major cause of damage and higher levels of cleanliness than presently attainable must be maintained. (With the laser in its present position, Rm 147 in Bldg. 101, there is probably continual contamination of the glass surfaces with both dust and oil vapours.)

The dimensions of the three glass rods are listed in Table 2, with the approximate energy densities at which the rods are working when the laser output is  $\sim 100\text{J}$ . As can be seen from this table, the only surface which approaches the damage level of  $20\text{J}/\text{cm}^2$  for damage caused by surface contamination, is the output surface of the second amplifier. Special care should be taken cleaning this surface and this rod needs to be apertured down to  $\sim 30\text{mm}$  so that laser light does not reach the edges of the output face. Because of rounding on this corner, the laser light can be concentrated and cause local damage.

### III. iii) The Laser Heads:

All three laser heads (the water-cooled optical cavities in which the glass laser rods are held) are standard C. G. E. laser heads. The oscillator head is a 16mm diameter, Z32 head; the first amplifier is a 23mm diameter x 320mm, T23/2 head; and the second amplifier is a 32mm

diameter x 500mm, T32/4 head.

A schematic of one of these heads is shown in figure 9. This is the first amplifier head (T23/2) with two flashlamps. Each head consists of an optical cavity similar to the one shown, with the water-cooled rod assembly running axially through the cavity. The cavity with its flashlamps is supported inside a light box, and the light box sits on an adjustable base (not shown).

By rotating the rod about its own axis the end faces of the rod can be set in a vertical plane. Then the adjustments on the base of the laser head allow one to move each end of the laser rod either horizontally or vertically, in each case rotating about the opposite end of the rod. Table 3 lists the number and type of flashlamp used in each laser head and the energy delivered to each flashlamp when the laser is set to deliver  $\sim 100\text{J}$  of laser pulse energy. Each flashlamp is powered by a  $42\mu\text{F}$  capacitor module with its own atmospheric pressure spark gap switch (Figure 10) and  $300\mu\text{H}$  inductor. The inductors are Brooks coils which give the maximum inductance for minimum resistance ( $< 10\text{ m}\Omega$ ). The spark gap switches are also low resistance ( $< 10\text{ m}\Omega$ ) so most of the stored electrical energy ( $3550\text{J}$ ) is deposited in the flashlamps.

These units are essentially the same as those used on the N. R. L. Glass Laser Facility and were designed under that project.

III. iv) The retro prism and oscillator output mirror:

The retro-reflecting prism, item (1) in figure 1 is a Schlieren free fused silica roof-prism from Oriel Corp. The return ray is said to be parallel to the incident ray within 1 sec of arc.

The oscillator output mirror is a single piece of high refractive

index glass with its two surfaces parallel to each other and polished so that it becomes an etalon. With refractive index  $n \sim 1.8$  at  $1.06\mu\text{m}$ , the Fresnel reflectance at normal incidence, is

$$R = \left( \frac{n - 1}{n + 1} \right)^2 = .082.$$

When used as a reflecting etalon the maximum reflectance, corresponding to the minima of the Airy formula for the transmission etalon, is

$$R' = \frac{4R}{(1+R)^2} = 0.28.$$

Because of the low reflectivity  $R$ , the etalon reflection is a sine wave with amplitude  $2R$ ,

$$R' \sim 2R (1 - \cos \Delta)$$

where  $\Delta$  is the optical retardation in the etalon. The thickness of the output mirror is  $\sim 1\text{mm}$ , therefore the reflectivity  $R'$  peaks at wavelength intervals of

$$\Delta\lambda_1 \sim 3 \times 10^{-4} \mu\text{m}$$

and many peaks occur within the fluorescence linewidth of the ED-2 glass.

### III. v) The Pockels Cells and Polarizers:

The Pockels cells, items (5) and (11) on the optical train shown in figure 1, are Lasermetrics Model 1073 50 $\Omega$  high speed Pockels cells. These are single crystal KD\*P cells in a strip line assembly. They have 16mm clear aperture and are said to be good up to 300 Mwatts/cm<sup>2</sup>. As described in Section II. (iii) we have experienced trouble with these cells under a constant voltage of  $\sim 3.5$  kV. The problem seemed to be electrode migration causing a steady decrease in the cell resistance

and eventually leading to sparking inside the Pockels cell enclosure. In the present pulsed mode of operation these cells appear to be functioning satisfactorily.

Table 4 gives the relevant characteristics of these Pockels cells as quoted by the manufacturers.

The polarizing plates used to make the polarizing units, items (4) and (12) in Figure 1, were produced by Laser Energy Inc. of Rochester, N. Y. They are glass plates (BK7 PH3) 75mm x 35mm x 7mm with polarizing dielectric coatings. The required angle of incidence is  $62^\circ$  when  $T_p = 96\%$  and  $T_s < 1\%$ . Two plates arranged as indicated in figure 1 provide adequate polarization to prevent normal mode lasing when crossed with the Lasermetrics Pockels cell, and cause no offset of the laser beam.

### III. vi) The Beam Expanders:

Two C. G. E. beam expanders are used in this laser system. They are items (13) and (15) in figure 1. Both are 32-45mm,  $\sqrt{2}$ , 6 degree afocal beam expanders and are mounted on C. G. E. adjustable mounts, which are shown in detail in figure 11.

### III. vii) The Calorimeters:

Two calorimeters, items (10) and (19) are permanently installed in the Laser system. They are routinely used to record the energy from the oscillator and the Laser output energy on every shot. In both cases the calorimeters are calibrated to give the energy that has passed through their respective beam splitters and not to include the extra  $\sim 5\%$  that is deflected into the calorimeter. Thus when the laser output is quoted at  $\sim 100\text{J}$ , in fact  $\sim 105\text{J}$  comes out of the second amplifier and  $\sim 100\text{J}$  actually passes through the beam splitter to become the Laser output

beam.

The oscillator output calorimeter is a CILAS (C. G. E.) laser calorimeter (PS 16) and the output calorimeter is a CILAS (CGE) CG64. The sensitivities as situated are  $185\mu\text{V}/\text{J}$  and  $.75\mu\text{V}/\text{J}$  respectively.

#### IV. Electrical Detail and Circuit Diagrams:

The electrical control and operating systems for this Nd/glass laser have all been assembled within this laboratory, mostly from commercially available components. No uniqueness nor originality is claimed for these systems but as they are, they have given reliable service, in most cases, for several years now.

##### IV. i) The Charging and Safety Interlock Circuits:

Before any part of the laser system can be activated, electrical power must be applied to the system. Unfortunately this must be done separately at several locations. This act turns on the water cooling system for the laser heads, the warning lights, and all electrical supplies except the high voltage charging units.

Now the primary control unit for both the charge/discharge circuits and the safety interlock circuits is the Slow Timer shown in Figure 2. This unit is a seven channel Eagle Timer with a range of approximately five minutes and is shown in detail in figure 12. Control of the start button of the Slow Timer can be switched to Local, ie at the Eagle Timer itself, Remote 1 (101/145), or Remote 2 (101/159).

Channel 1 in the Slow Timer is used as an internal latch. As soon as the start switch is closed, channel 1 closes. Then, provided the five safety interlock circuits ( (1) through (5) in figure 12) are closed the Slow Timer starts running. If any one of the safety inter-

lock circuits is open, the Slow Timer cannot start. Also if any one of these safety interlock circuits opens at any time during the charge/fire cycle, the Slow Timer stops and immediately opens all seven timing channels. This action renders the laser safe within a few seconds.

The five safety interlock circuits are shown in detail in figure 13. Circuits (1) and (3) each contain only a single switch. These are the stop buttons on the two Remote Control panels in rooms 101/145 and 101/159. Notice that these stop (or dump) switches remain effective even when control of the start button is not given to that particular Remote Control Panel. This is true of all the safety interlock circuits! Only control of the start switch is switched from one control room to another. Thus at any time only one Control Panel can start the Charge/fire cycle; but any of the safety interlock circuits can stop it.

Safety interlock circuits (2) and (4) are available at Remote Control Panels (1) and (2) respectively. They are intended to be used for door-operated switches for laboratories 101/145 and 101/159. However we have so far found that passive warning devices i.e. flashing red lights on the outside of doorways and loud bells or sirens in the laboratories, are enough to ensure safety.

Safety interlock circuit (5) is the safety circuit for the laser itself. Both doors to the Laser Room (101/147) have door operated switches on them; the three cooling water circuits for the laser rods contain waterflow operated switches; and close to the flashlamp capacitor modules there is a shorting bar ("chicken stick") which when hanging in its proper place closes another switch.

Each of these five safety interlock circuits has a warning light so

that when any of these circuits is opened it is easily indentified.

Assuming that the safety interlock circuits are all closed and the start switch has been pushed, the Slow Timer starts to run. After about 10 seconds timing channel II closes. This activates the dump relays (DR-1A, DR-1B, and DR-1C) shown in figure 14 and disconnects the capacitor modules from their grounding resistors. A few seconds later timing channel III closes and activates the charge relays (CR-2A, CR-2B, and CR-2C) which are also shown in figure 14. Now the flashlamp capacitor modules (indicated by C in figure 14) are ready for charging to begin.

Timing channels IV and V close. Timing channel V activates the relay (CR-1 in figure 15) which applies the 22 kV output of High Voltage Power Supply (2) to the 0.1  $\mu$ F Trigger capacitor. Timing channel IV switches on the high voltage circuits in High Voltage Power Supply (1) (Figure 16). This power supply contains a motor driven variac which gradually increases the output voltage to 20 kV.

H. V. P. S. (1) charges all the flashlamp capacitor modules in parallel as indicated in figures 2 and 14. But each group of capacitor modules (oscillator, 1st amplifier, and 2nd amplifier) has its own voltage monitoring circuit (Figures 14 and 17). The desired capacitor charging voltages are set beforehand on the Meter Relays MR-A, MR-B, and MR-C shown in figure 17. When the capacitor charging voltage reaches its preset value the appropriate meter relay is activated. This activates the appropriate intermediate relay (RE-2A, B, or C) and in turn de-activates the proper charging relay (CR-2A, B, C). So the group of capacitor modules that has reached its desired charging voltage, is disconnected from H. V. P. S. (1). When all three groups of capacitor

modules have reached their respective charging voltages the laser ready light comes on; the counter counts once; and relays RE-1A, B, and C are activated.

The purpose of the RE-1 relays is to protect the meter relays from transients produced when the flashlamps are fired. Thus when the RE-1 relays are activated the meter relays are disconnected from the capacitor metering circuits and caused to go to full scale deflection (Figure 17). To give adequate insulation against these transients the RE-1 relays are immersed in transformer oil (they are small 110 v.d.c. relays with insulation good to perhaps 1000 volts). Also these relays and the wires leading to them are protected against high voltage by a neon bulb and a spark gap as shown in figure 14. We have found all these protective devices necessary to preserve the rather delicate meter relays.

Once the three groups of capacitor modules are charged and disconnected from the power supply (HVPS 1), this supply "overvolts" and cuts off.

To charge the three groups of capacitor modules to around 13 kV, takes about 60 seconds. Timing channel VI closes about 10 seconds before the capacitors are fully charged. This activates relays in the chart recorders (figure 18) which record the outputs of the laser calorimeters. The chart recorders are from Varian Associates and have been modified by inserting a relay in parallel with the record switch. Each chart recorder is fed by a microvoltmeter which measures the calorimeter output

#### IV. ii) The Laser Firing Circuits:

With the flashlamp capacitors charged and disconnected from both

the charging supply and the voltage measuring circuits, the Nd/glass laser is ready to fire. As described in Section II, iii), because of our experience with the Lasermetrics Pockels cells, these cells are not biased continuously. Instead they receive a slow bias pulse starting when the flashlamp switches are fired. After the predetermined optical pumping time, a fast gating pulse of opposite polarity to the bias pulse, opens the Pockels cells and laser action begins.

The flashlamp firing circuit is shown in figure 10. Although different flashlamps are used in the different laser heads (see Table 3), each lamp is powered by an identical  $42\mu\text{F}$  capacitor module, air-filled spark-gap switch, and  $300\mu\text{H}$  inductor (Section III, iii). To fire the flashlamps, a trigger pulse from the master switch (MS-1 in figure 15) is applied to the pulse transformer (shown in figure 10) on each capacitor module via the connections D'D (figures 2, 10, and 15).

The Pockels cells' pulse forming networks are shown in figures 19 and 20. The slow bias pulse (figure 5) is generated by the conventional thyratron circuit shown in figure 19.

The fast rising gating pulses are generated by using lengths of coax cable. Upon discharge these produce square pulses. The complete circuit for producing both the prepulse and the main pulse is shown in figure 20.

Pockels cells PC1 and PC2, are connected in series with approximately  $10\text{m}$  ( $50\text{nsec}$ ) of cable between them. Pulses coming out of PC2 pass through almost  $70\text{m}$  of coaxial cable before reaching the  $50\Omega$  terminator. This terminator is connected to the cable via a capacitor ( $5 \times 10^4$  pf) so that the fast gating pulses see the  $50\Omega$  terminator but the

slow bias pulse stops at the capacitor. The  $50\Omega$  terminator is also a voltage divider which allows us to monitor the gating pulses. The long cable (70m) between the Pockels cells and the terminator was chosen deliberately so that any reflections caused by mismatch at the terminator could not return to the Pockels cells in time to influence the laser pulse shape.

The slow bias pulse is fed to the Pockels cells through a  $1k\Omega$  resistor which isolates the bias pulse generator from the fast pulse circuits. Notice the slow bias pulse is put directly on the center conductor of the Pockels cell cable and there is approximately 10m of cable between the pulse generating circuits and the first Pockels cell (PC1).

To generate the two fast gating pulses two separate lengths of RG/8 coax cable are used. These are coiled and placed in a 19" chassis. The 300 nanosecond main pulse requires a  $34m$  length of cable and the 150 nanosecond prepulse requires a  $17m$  length of cable. The outer conductors of these cables are charged to  $-6.8kV$  through two  $10M\Omega$  resistors as shown. They are also connected to ground by two RC smoothing networks ( $R = 100\Omega$ ,  $C = .03\mu F$ ). These networks reduce the coupling of the slow bias pulse on to the outer conductors of the cables to an acceptable level. They do not affect the generation of the fast gating pulses!

Two open air spark-gaps (SG-1 and SG-2 in figure 20) are used to start the fast gating pulses. They are each fired directly by E. G. & G. TM-11 trigger modules. Firing SG 2 grounds that end of the outer conductor of the  $17m$  pre-pulse cable so causing a positive pulse on the center conductor. The length of the pulse is the double transit time of

the cable ( $\sim 150$  nsec) and the amplitude is just half the charging voltage. Remember that at the time SG-2 is fired SG-1 is still open circuit.

Once the prepulse has been launched, the main pulse can be initiated by firing SG-1. Notice now that when the main pulse arrives at SG-2, this switch must still be conducting. Therefore the delay between the two pulses cannot be longer than the recovery time of SG-2. But this time is much longer than any delays of interest ( $< 5 \mu\text{sec}$ ).

With this simple pulse generating system the only way of controlling the relative amplitude of the laser prepulse and mainpulse, is through the gain in the oscillator rod. This is usually done by changing the charging voltage of the oscillator flashlamp capacitors.

The laser can be converted to single pulse output simply by shorting SG-2 and removing the  $10M\Omega$  charging resistor to the prepulse cable.

To fire the flashlamps, the slow bias pulse, and the Pockels cell pulses; and to synchronize the Nd/glass laser with other systems requires the Fast Pulse Timer, (Figure 2). This unit is shown in detail in figure 21. The heart of the Fast Pulse Timer is an Ortec 401A BIN containing a Dual Discriminator (T105/N), five Gate and Delay Generators (416A), a Gate Generator (GG202/N), and Dual Fanout (F108/N). The Discriminator converts any pulse to a clean logic pulse which is used to fire the first half (C1) of the Gate Generator and the first Delay Generator (B1). B1 gives a prompt,  $T=0$ , pulse for external synchronization. After a delay of  $700\mu\text{sec}$ , C1 fires the top half (D1) of the Fanout which in turn fires the bottom half of the Gate Generator (C2) and the Delay Generator, B2. After a further delay of  $300\mu\text{sec}$ , C2 fires the

bottom half of the Fanout (D2) which fires the three Delay generators B3, B4, and B5.

An output pulse (7) from Delay Generator B2 is used to fire a slow time base oscilloscope to monitor the fluorescence radiation in the oscillator rod (Figures 3 and 7). And an output pulse (8) from Delay Generator B4 fires a fast time base oscilloscope to monitor the Pockels cell pulses or the oscillator output (Figures 6 and 7). The other Delay Generator outputs feed directly into small thyratron pulse generators which convert their 10 volt outputs to 300 volt low impedance outputs (E1 through 6). Finally notice that all pulses into and out of the Fast Pulse Timer go through ground loop inductors to protect the Timer against spurious pulses.

In this way the Fast Pulse Timer generates eight output pulses from the one input pulse. These pulses both control the firing sequence of the laser and allow synchronization with other systems at different times during the firing sequence. The eight outputs are listed in figure 21.

#### V. Acknowledgement:

We gratefully acknowledge the considerable assistance we have received from members of the Laser-Matter Interaction Group at N. R. L. especially J. M. McMahon, T. H. Derieux and R. P. Burns. Messrs E. Laikin, James W. Cheadle, and E. Turbyfill provided technical assistance at different stages in the construction of this laser.

Table I. Physical properties of Owens-Illinois ED-2 laser glass.

Neodymium doping	3.1 wt.%
Neodymium concentration	$2.83 \times 10^{20}$ Nd ions/cm <sup>3</sup>
Cross-section for stimulated emission	$3.03 \times 10^{-20}$ cm <sup>2</sup>
Fluorescence line width (at 300°K)	300μsec
Specific gain	0.16/cm/joule stored/cm
Fluorescence line width (at 300°K)	0.260μm
Center lasing wavelength	1.0623μm
Damage threshold	~ 20 J/cm <sup>2</sup> in a 30 nsec pulse
Density	2.547 g/cm <sup>3</sup>
Refractive index at 1.06μm	1.555
Refractive index at 6328 Å	1.564
Linear coefficient of thermal expansion	$103 \times 10^{-7}$ /°C
Average power input limit (for water cooled cavities)	200 W/inch

Table 2. Dimensions of the ED-2 glass laser rods.

	length (mm)	diameter (mm)	Energy density <sup>2</sup> J/cm <sup>2</sup>
Oscillator	260	16	~ 2
1 <sup>st</sup> Amplifier	320	23	~ 6
2 <sup>nd</sup> Amplifier	500	32	~14

1. All rods have end faces cut at  $6^\circ$  to their cylindrical axes, with end faces parallel to each other.
2. This is the approximate energy density at the output surface of the rod for conditions under which the total laser output is  $\sim 100$  J.
3. The intensity in the oscillator may be estimated as  $\sim \frac{I_o}{1-R^1}$ , where  $I_o$  is the intensity coming out of the oscillator and  $R^1$  is the reflectivity of the output mirror ( $R^1 \sim 0.28$  for the etalon reflector, Section III iv).

Table 3. Flashlamp specifications and Pumping energy.

Unit	Flashlamp Type	No.	Energy/lamp J
Oscillator	L-1407 (HB-12)	1	3550
1 <sup>st</sup> Amplifier	L-1408 (HB-23)	2	3550
2 <sup>nd</sup> Amplifier	L-562 (HB-19)	4	3550

Table 4 Lasermetrics Model 1073 Pockels Cells.

Aperture	16mm
Crystal	KD*P
Configuration	stripline
Peak Optical power	300 Mwatts/cm <sup>2</sup> Q-switched.
Spectral range	0.4 → 1.3 μm.
extinction ratio	600:1
1/4 wave retardation voltages (kV)	
@ .580μm	1.75 kV
@ .684μm	2.1 kV
@ 1.96μm	3.2 kV
(typical)	
risetime	< 500 x 10 <sup>-12</sup> sec.

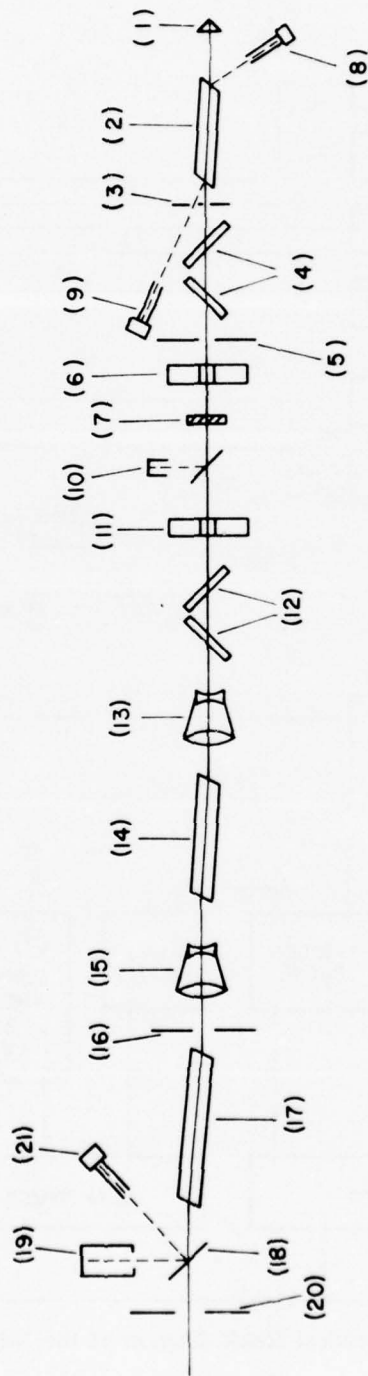

Fig. 1 — Schematic diagram of the optical train of the Nd/glass laser

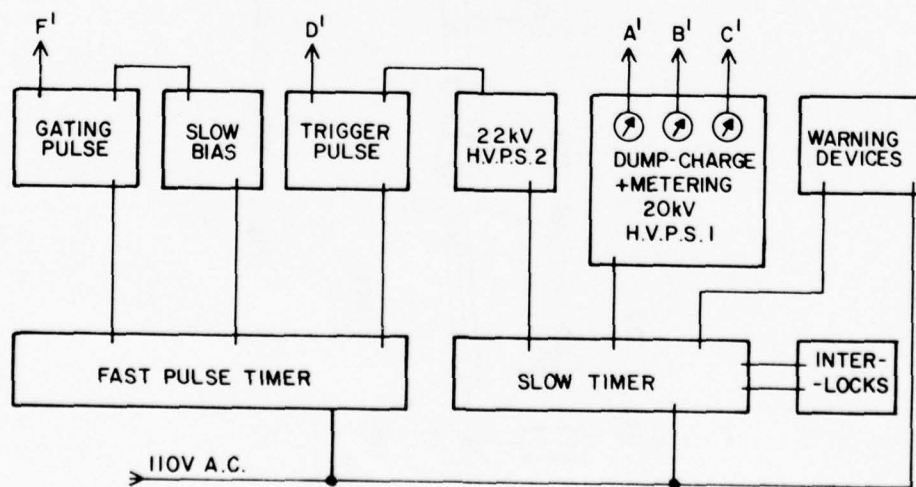
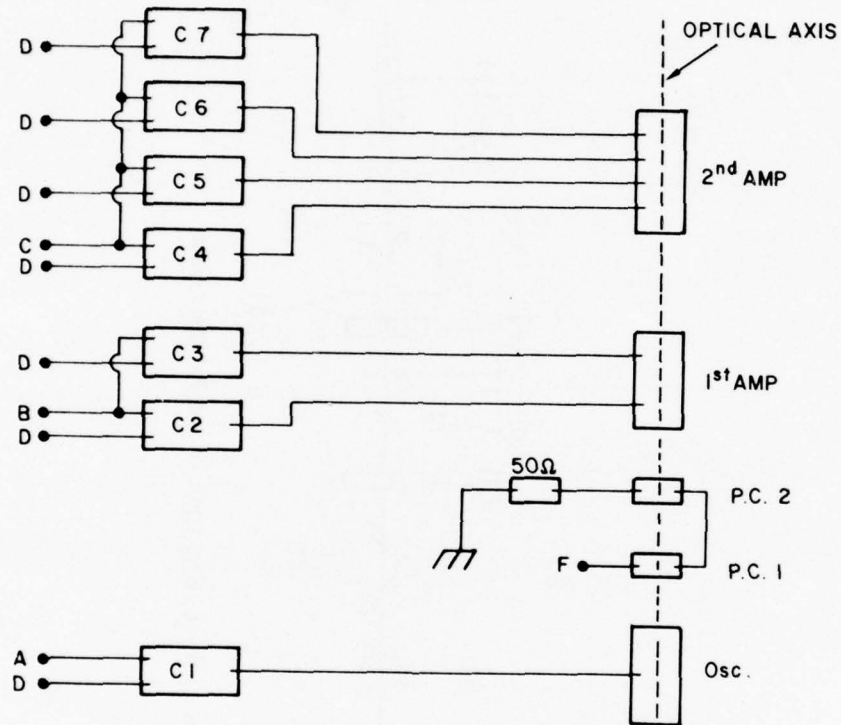

Fig. 2 — Electrical block diagram of the Nd/glass laser

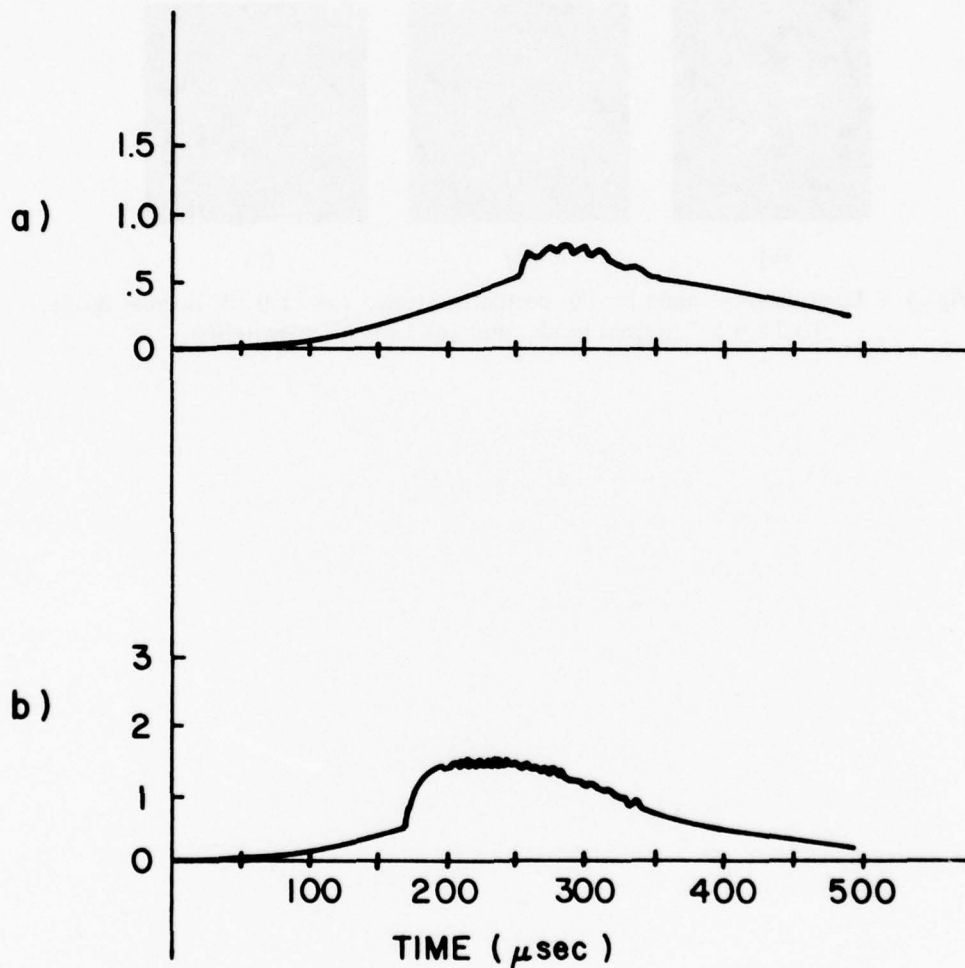
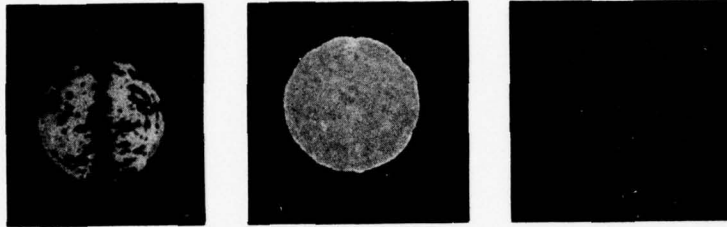

Fig. 3 — Fluorescence in the oscillator rod during normal mode lasing.  
 (a) 10.5 kV, and (b) 13.0 kV. Time base 50  $\mu\text{sec}$ /division.



(a)

(b)

(c)

Fig. 4 — Burn pattern made by the oscillator alone. (a) 11.0 kV normal mode, (b) 13.0 kV normal mode, and (c) 13.0 kV q-switched.

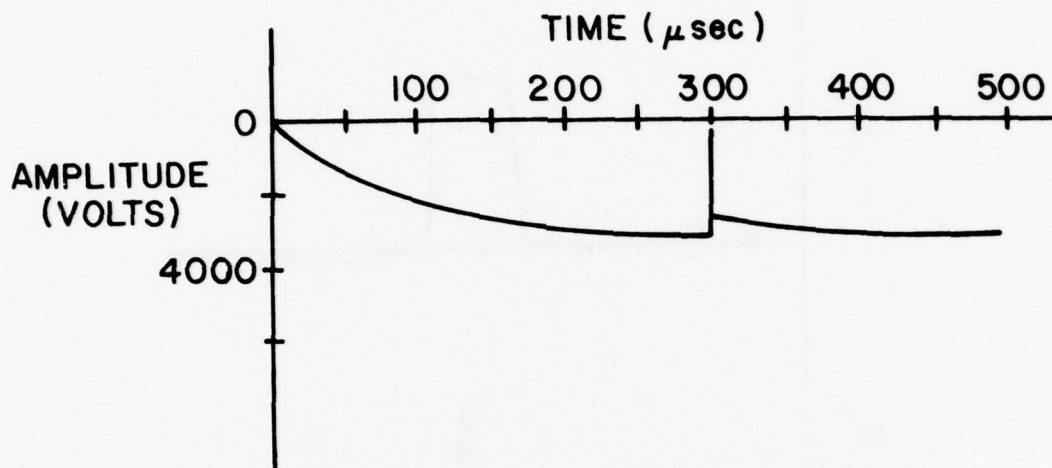

Fig. 5 — The slow bias pulse for the Pockels cells. Time base 50  $\mu$ sec/division, amplitude 2000 volts/division.

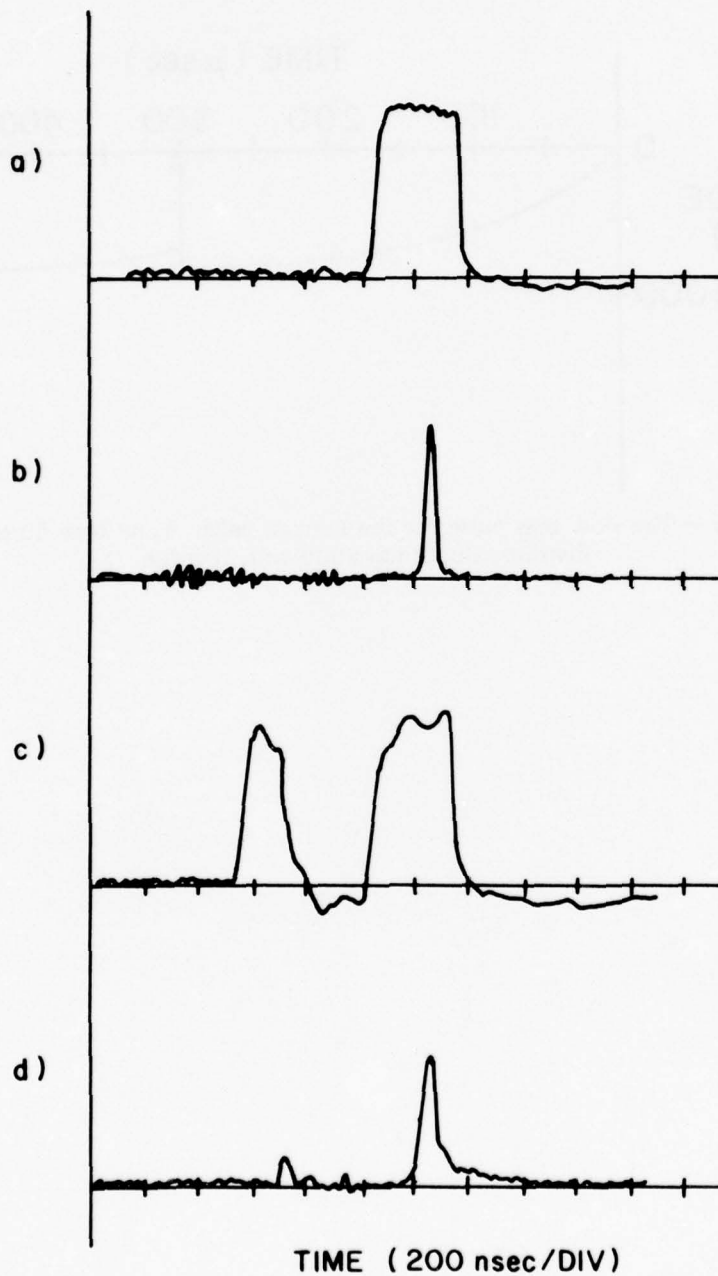

Fig. 6 — Pockels cell gating pulses and oscillator output. (a) 300 nsec single gating pulse, (b) oscillator output generated by (a) (diode (9) Fig. 1), (c) 150 nsec and 300 nsec gating pulses, and (d) laser output generated by (c) (diode (21) Fig. 1). Time bases 200 nsec/division.

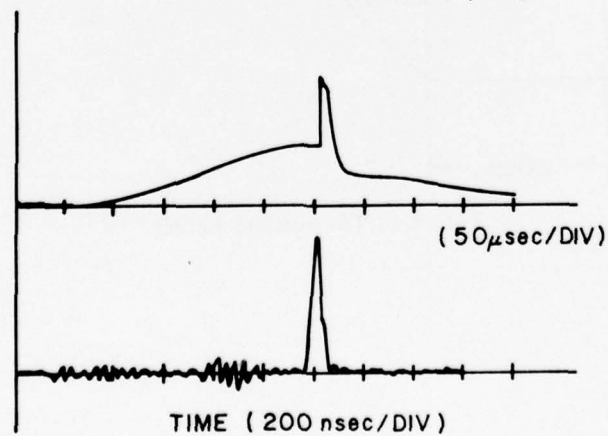
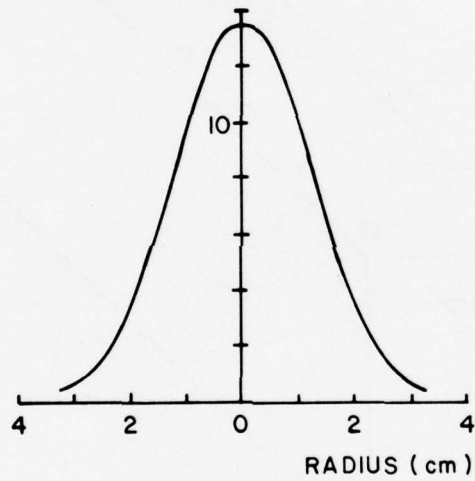
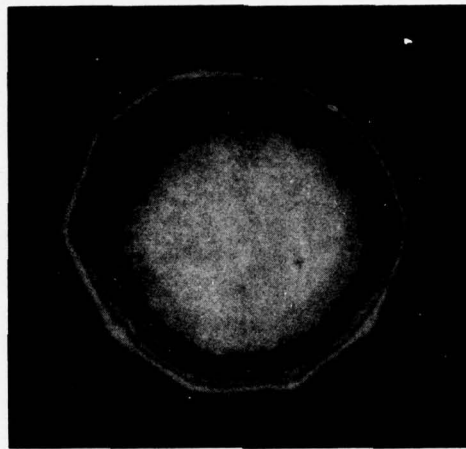

Fig. 7 - A 100 J, 40 nsec laser output pulse, (a) burn pattern at  $\sim 6m$ , (b) radial energy density distribution, (c) fluorescence radiation in the oscillator rod, and (d) oscillator output pulse recorded by diode 9 (in Fig. 1).

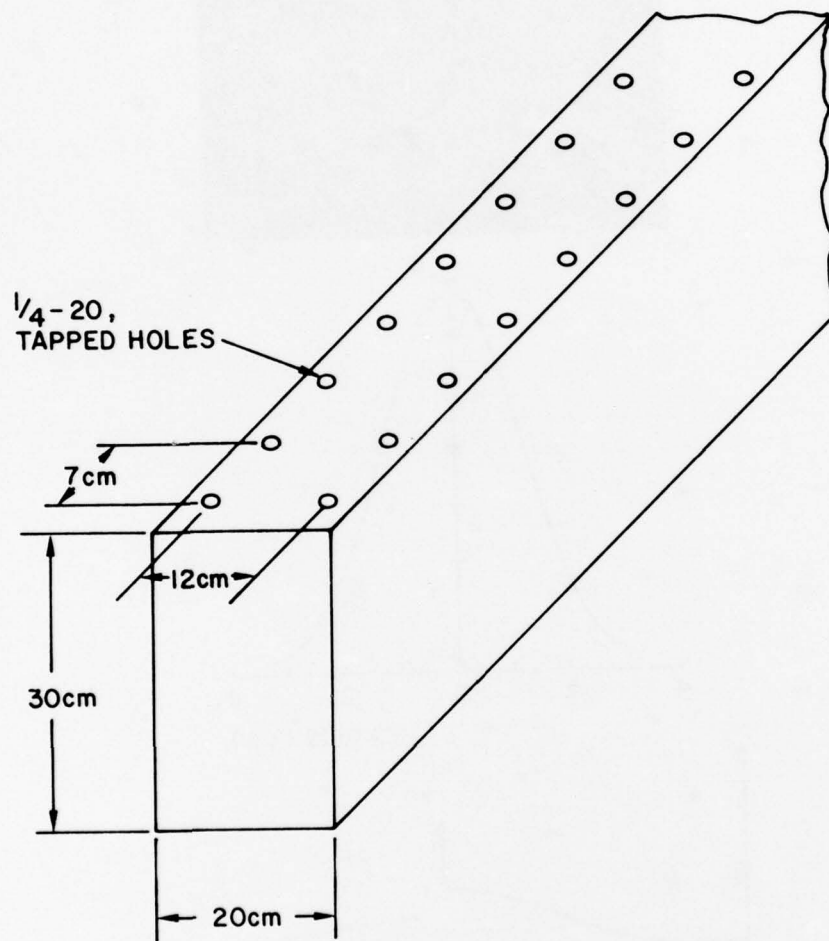

Fig. 8 - The optical bench

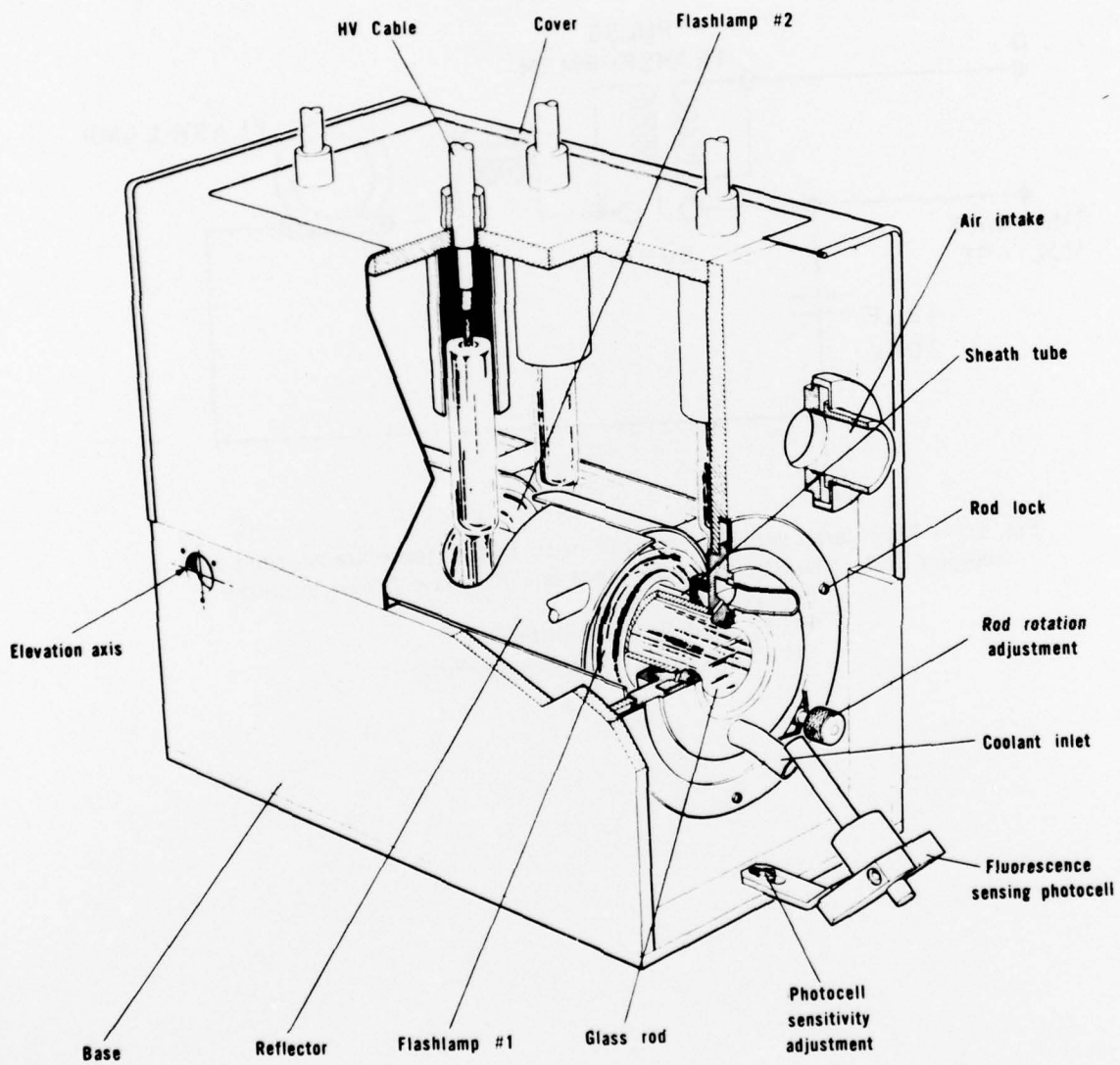

Fig. 9 — A CILAS T 23/2 laser head

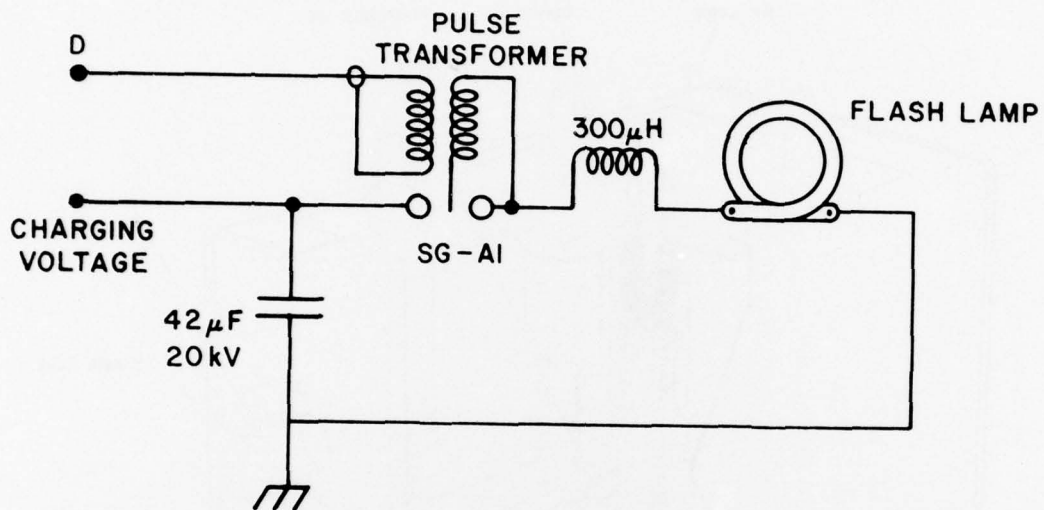

Fig. 10 — Flash lamp capacitor module with trigger pulse transformer and charging lead. The  $300 \mu\text{H}$  inductance is a Brooks coil cast in epoxy.  
 SG-A1, oscillator  
 SG-B1, and 2, 1st amplifier  
 SG-C1, 2, 3, and 4, 2nd amplifier.

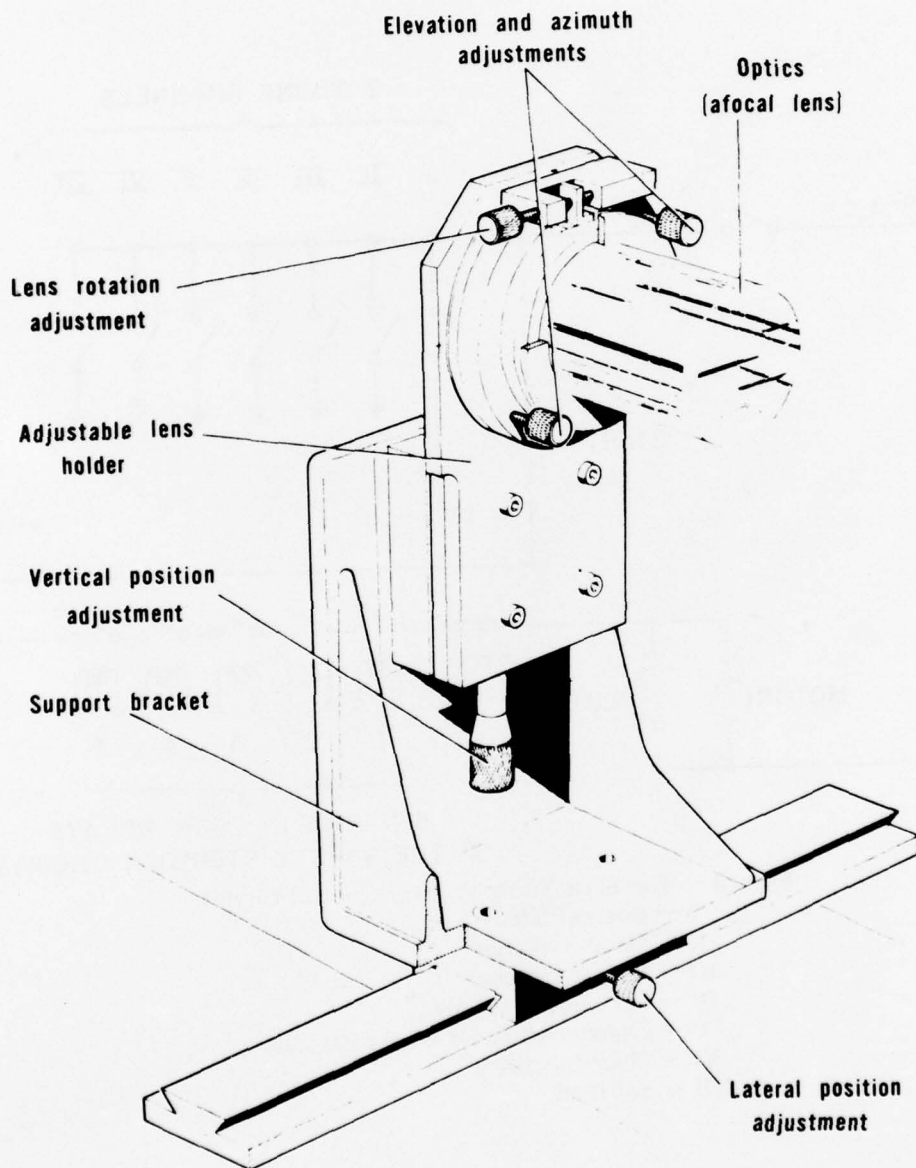

Fig. 11 — A CILAS beam expander and adjustable mount

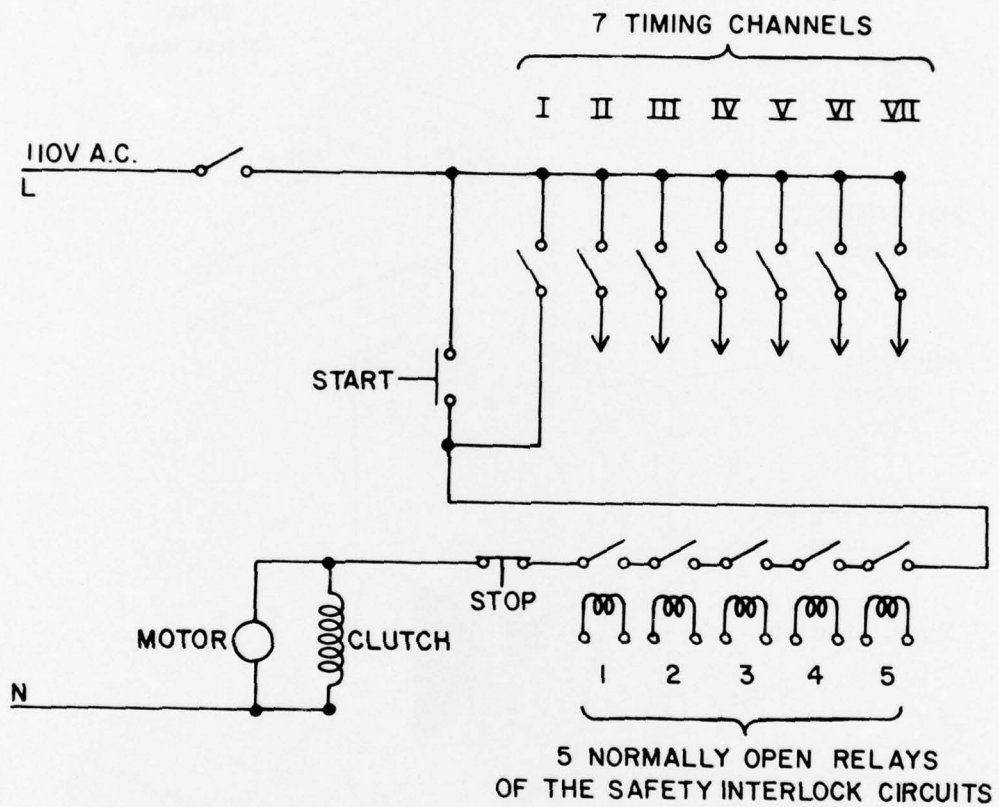
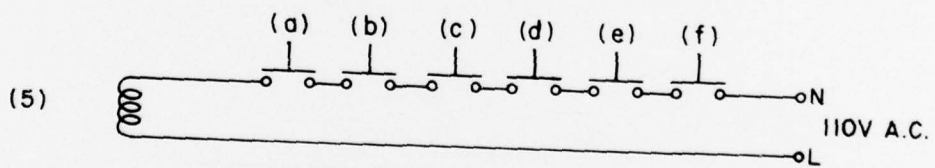
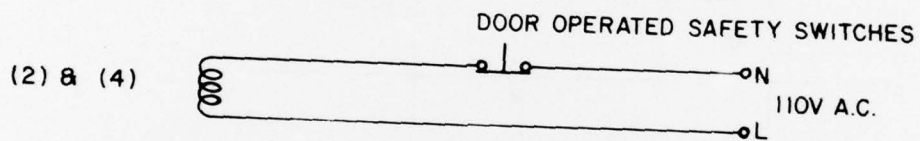
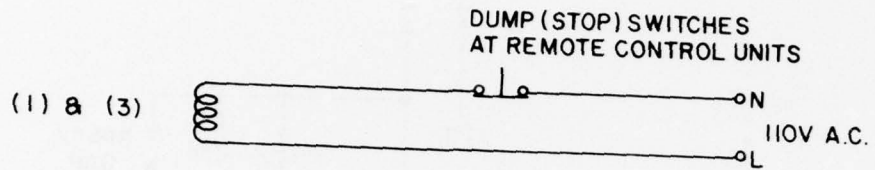

Fig. 12 - The Slow Timer Primary Control Circuit

- I - Internal latch
- II - Dump switches
- III - Charge switches
- IV - H.V. power supply
- V - Charge switch for trigger capacitor
- VI - Chart recorders
- VII - not used.



(a) , (b) TWO DOORS INTO LASER ROOM

(c) , (d) , (e) COOLING WATER FLOW SWITCHES

(f) CAPACITOR SHORTING BAR SWITCH

Fig. 13 - Safety interlock circuits

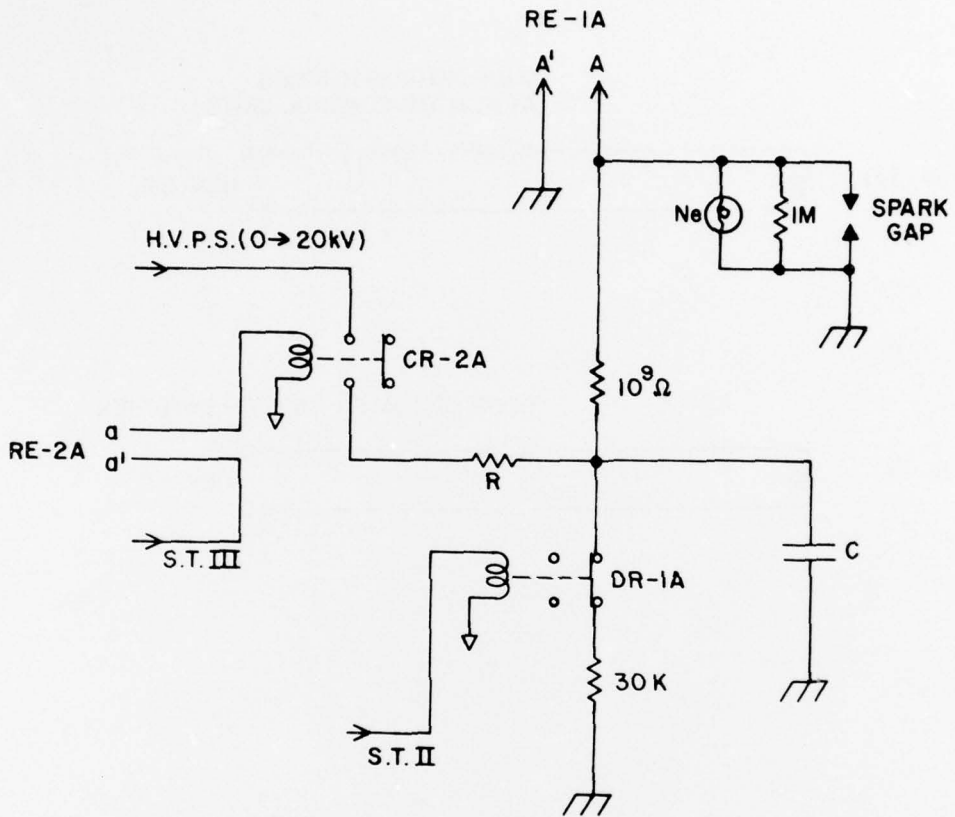

	LETTER	R	C
OSCILLATOR	A , a	1.6	42
1 <sup>ST</sup> AMP	B , b	.8	84
2 <sup>ND</sup> AMP	C , c	.4	168
		MΩ	μF

Fig. 14 — Charging, dumping and measuring circuits

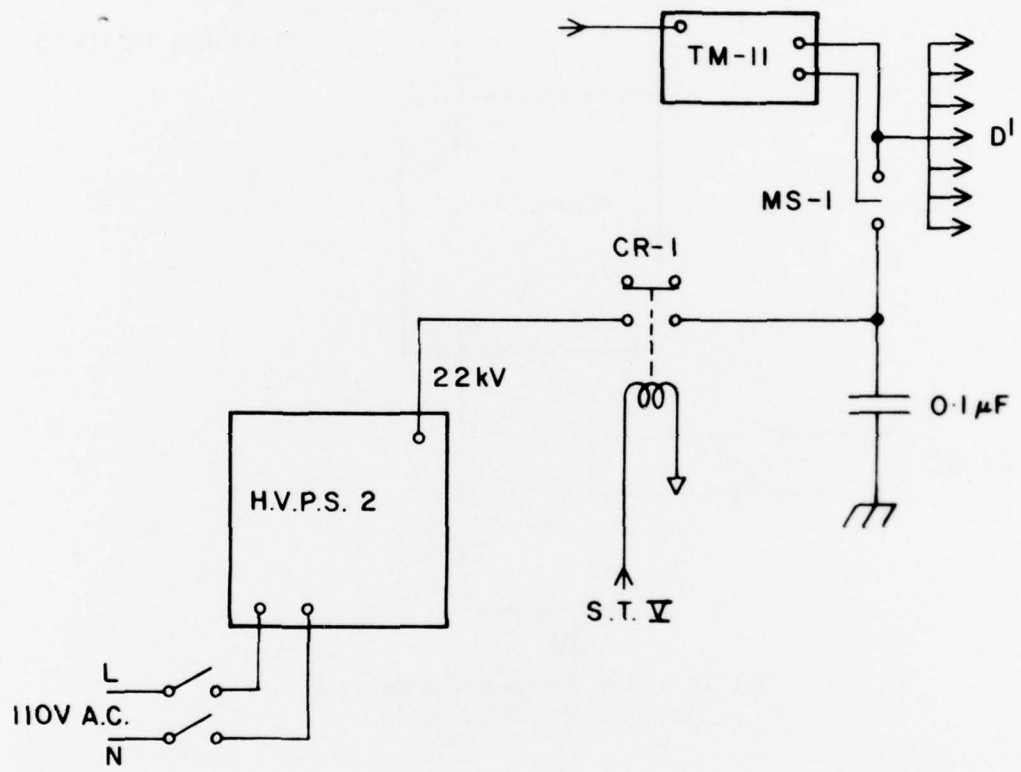

Fig. 15 - Trigger pulse generating circuit

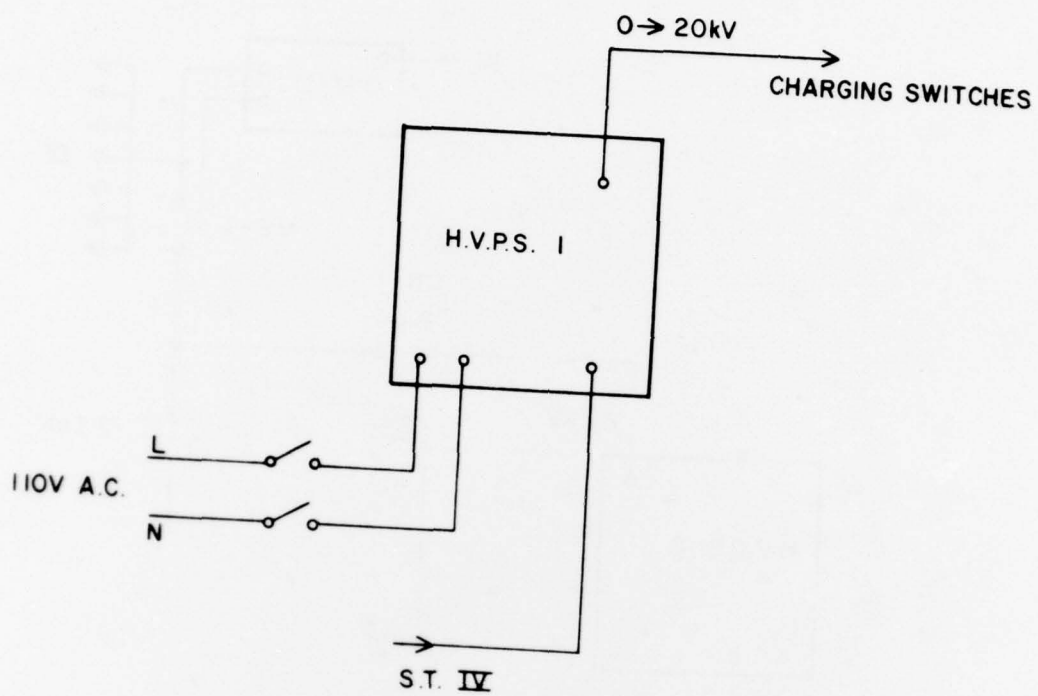

Fig. 16 — High voltage power supply 1  
(Universal Voltronics Corp.)

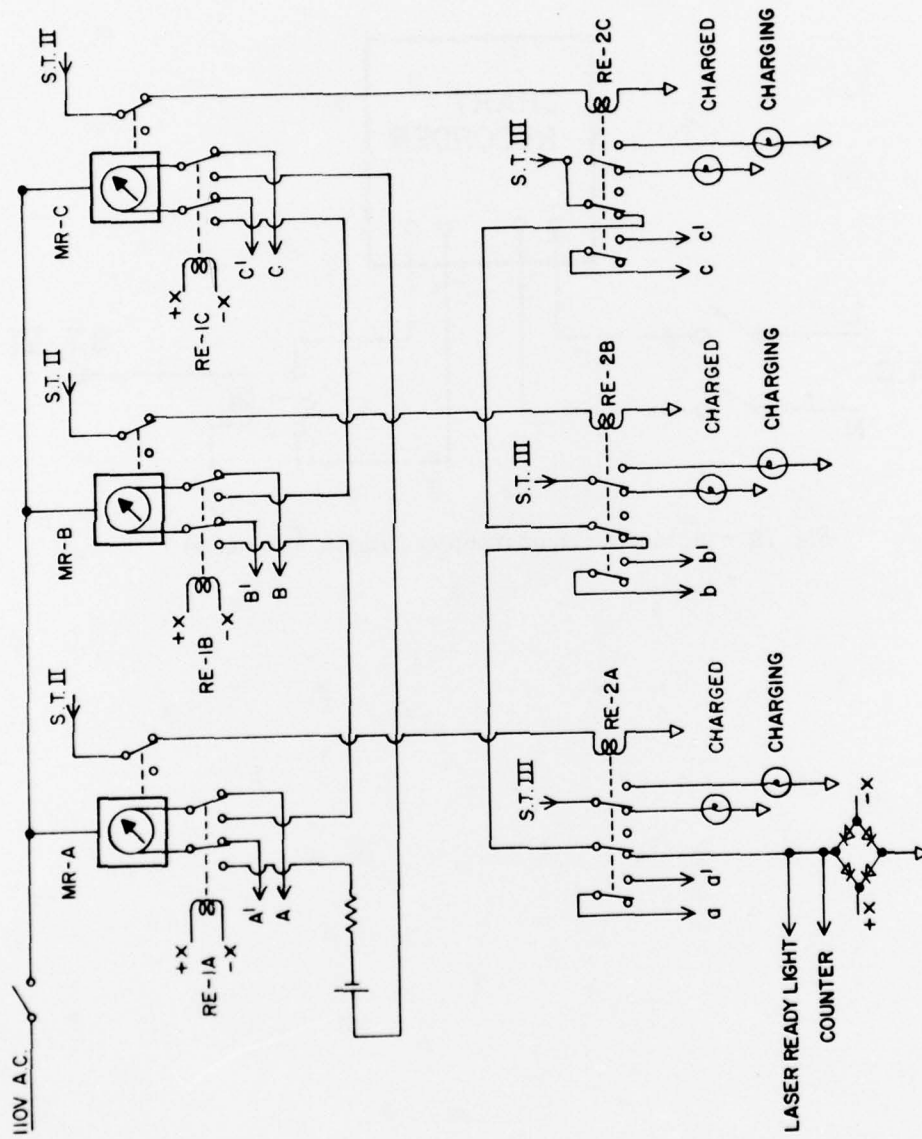

Fig. 17 — The meter relay circuits

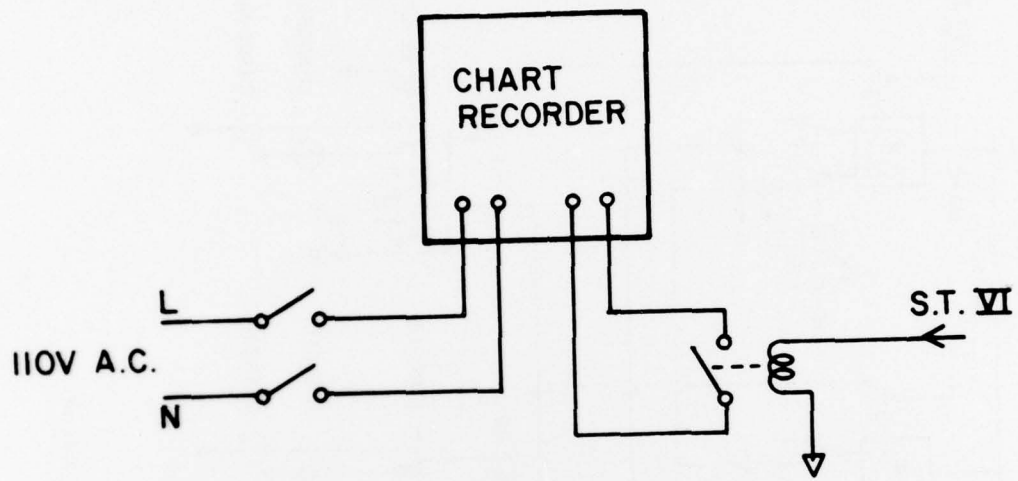

Fig. 18 - Automatic chart recorder (Varian Associates)

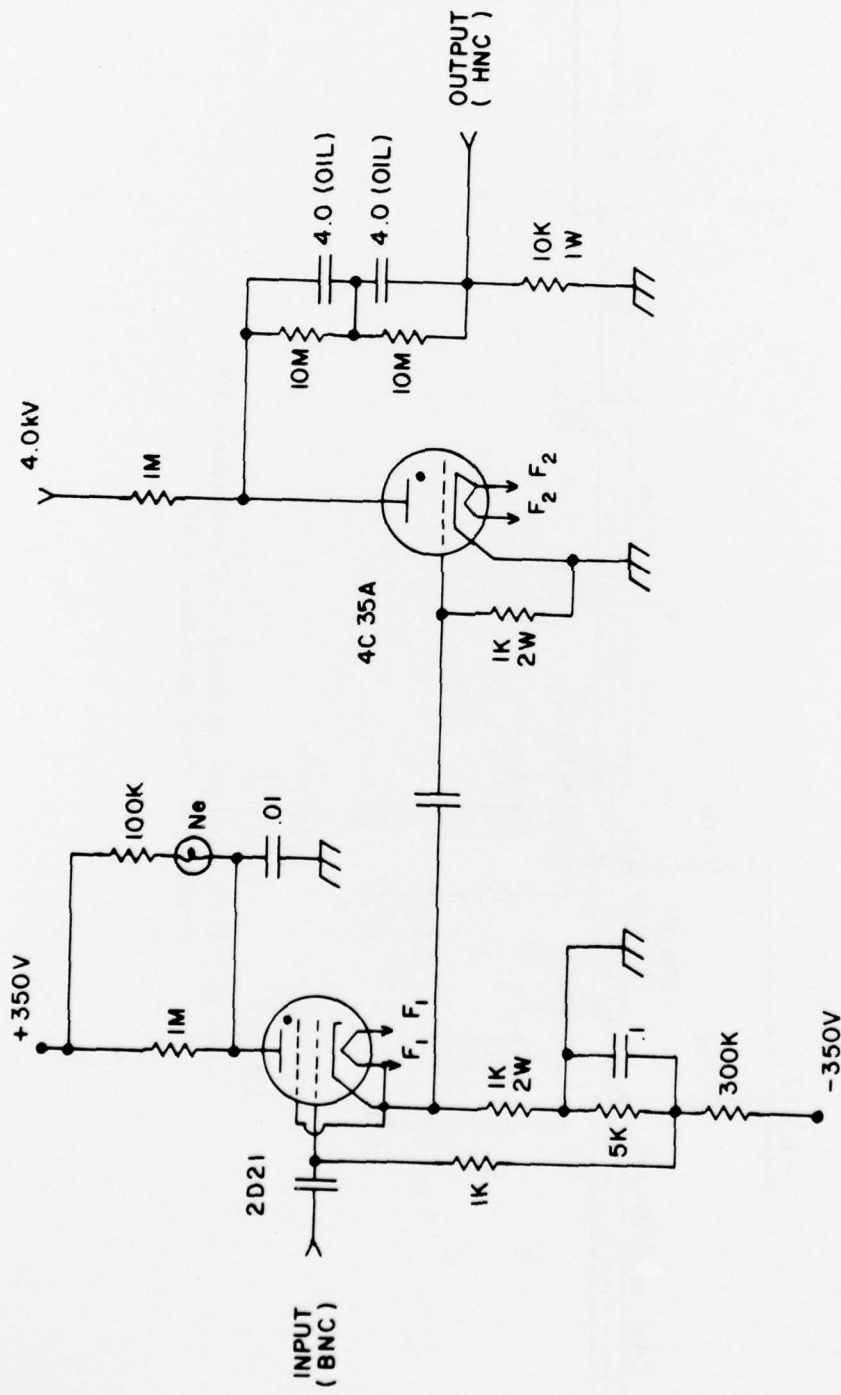

Fig. 19 - Slow bias pulse generator circuit. (All resistors in Ohms, 1/2 watt unless specified; capacitors in  $\mu\text{F}$ .)

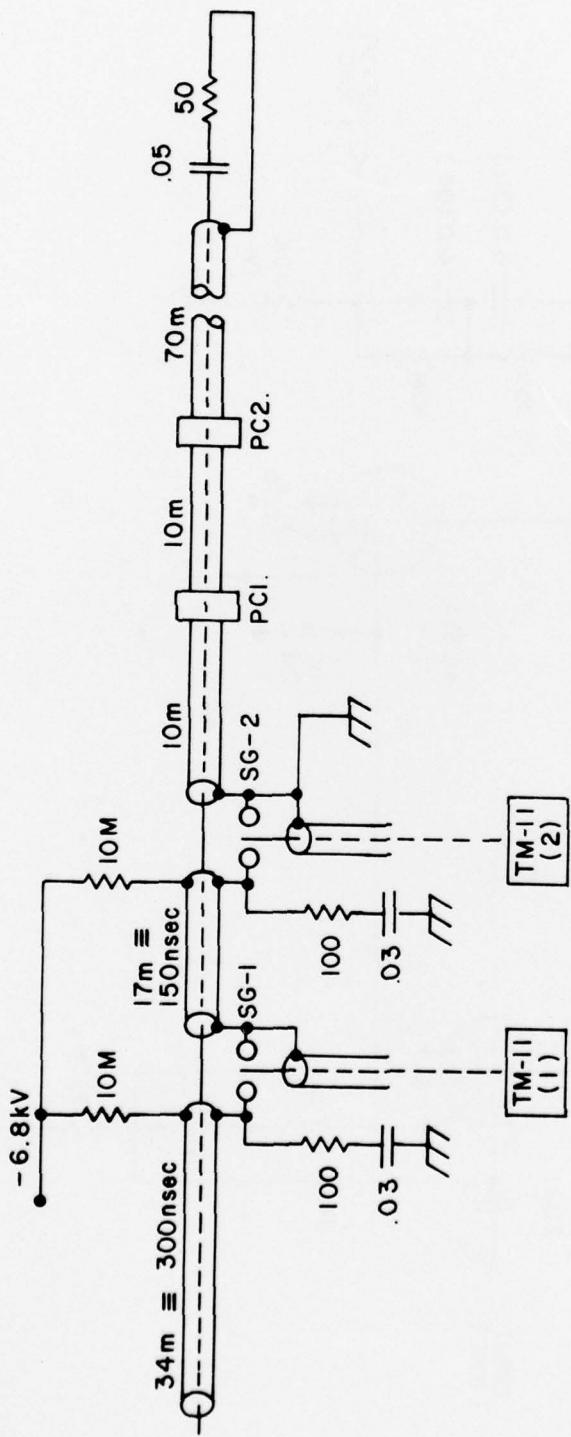

Fig. 20 — Pockels cell pulsing circuit. (All cables are RG/8; resistance in ohms; capacitance in  $\mu\text{F}$ .)

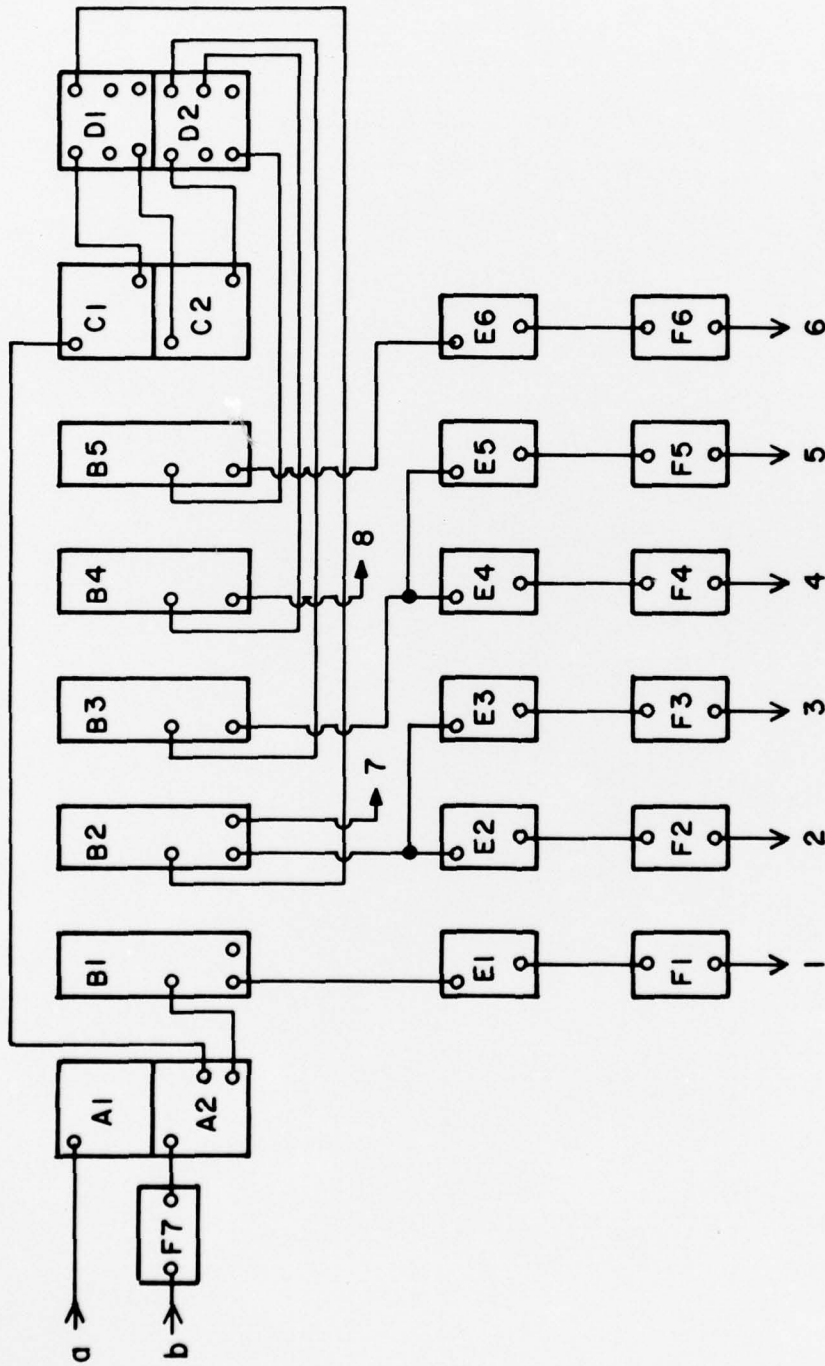

Fig. 21 — The fast pulse timer, (a) manual and (b) pulse

- A. T105/N dual discriminator
  - B. 416 A gate and delay generator
  - C. GG 202/N gate generator
  - D. F108/N dual fanout
  - E. Thyratron (2D21) 300 v pulse generator
  - F. Ground loop inductor
1. External sync (T = 0 →)
  2. Flash lamp (T = 705 μsec)
  3. P.C. bias pulse (T = 705 μsec)
  4. P.C. main pulse (T = 1005 μsec)
  5. External sync (T = 1005 μsec)
  6. P.C. prepulse (T = 1004.4 μsec)
  7. C.R.O. trigger (50 μsec/cm)
  8. C.R.O. trigger (200 nsec/cm)