

AD-A039 654

NAVAL POSTGRADUATE SCHOOL MONTEREY CALIF
A PERSONALIZED SYSTEM OF INSTRUCTION FOR AIRCRAFT PERFORMANCE. (U)
MAR 77 D L FINCH

F/G 5/9

UNCLASSIFIED

NL

1 of 5
ADA
0 39654



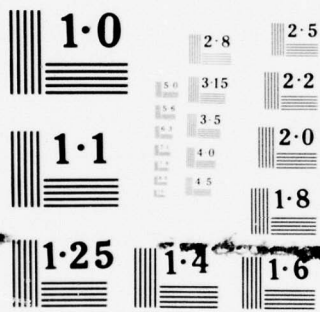

NATIONAL BUREAU OF STANDARDS
MICROCOPY RESOLUTION TEST CHART

AD A 039654

2

NAVAL POSTGRADUATE SCHOOL

Monterey, California



DDC
PARMIL
MAY 19 1977
RESERVE
C

THESIS

A PERSONALIZED SYSTEM OF INSTRUCTION
FOR AIRCRAFT PERFORMANCE
by
Donald Leslie Finch
March 1977
Thesis Advisor: D. M. Layton

AD No. _____
DDC FILE COPY

Approved for public release; distribution unlimited.

REPORT DOCUMENTATION PAGE		READ INSTRUCTIONS BEFORE COMPLETING FORM
1. REPORT NUMBER	2. GOVT ACCESSION NO.	3. RECIPIENT'S CATALOG NUMBER
4. TITLE (and Subtitle) A Personalized System of Instruction for Aircraft Performance.		5. TYPE OF REPORT & PERIOD COVERED Master's Thesis, March 1977
7. AUTHOR(s) Donald Leslie/Finch		6. PERFORMING ORG. REPORT NUMBER
9. PERFORMING ORGANIZATION NAME AND ADDRESS Naval Postgraduate School Monterey, California 93940		8. CONTRACT OR GRANT NUMBER(s)
11. CONTROLLING OFFICE NAME AND ADDRESS Naval Postgraduate School Monterey, California 93940		10. PROGRAM ELEMENT, PROJECT, TASK AREA & WORK UNIT NUMBERS
14. MONITORING AGENCY NAME & ADDRESS (if different from Controlling Office) Naval Postgraduate School Monterey, California 93940		12. REPORT DATE March 1977
		13. NUMBER OF PAGES 411
		15. SECURITY CLASS. (of this report) Unclassified
		18a. DECLASSIFICATION/DOWNGRADING SCHEDULE
16. DISTRIBUTION STATEMENT (of this Report) Approved for public release; distribution unlimited. 12/4149		
17. DISTRIBUTION STATEMENT (of the abstract entered in Block 20, if different from Report)		
18. SUPPLEMENTARY NOTES		
19. KEY WORDS (Continue on reverse side if necessary and identify by block number) Personalized System of Instruction; Descent Performance; Range; Self-Paced; Aircraft Instrumentation; Cruise Climb; Endurance; Proctorial; Drag; Power Required; Maneuvering Flight; Aircraft Performance; Thrust Required; Takeoff Performance; Atmosphere; Climb Performance; Landing Performance		
20. ABSTRACT (Continue on reverse side if necessary and identify by block number) A personalized system of instruction utilizing self-con- tained text material and combining the principle of auto- tutorial instruction with modified self-pacing was developed for a course in aircraft performance. The course material, contained in Appendix A, was applied to the aircraft perform- ance portion (six weeks) of a 12 week course in aircraft per- formance, control and stability taught to 11 students in the		

DDPC
 PREPARED
 MAY 19 1977
 MILITARY

252 450

Department of Aeronautics at the Naval Postgraduate School, Monterey, California, during the summer quarter of 1976. The course results, summarized in Appendix B and C, tended to confirm the advantages and substantial value of this instructional method.

In addition, the course material will be utilized by the Office of Continuing Education, Naval Postgraduate School, Monterey, in its program of offering basic background courses off campus in preparation for graduate study.

	White Section	<input checked="" type="checkbox"/>
	Buff Section	<input type="checkbox"/>
BY DISTRIBUTION/AVAILABILITY CODES		
Dist.	AVAIL. CODE	SPECIAL
A		

Approved for public release; distribution unlimited.

A Personalized System of Instruction
for Aircraft Performance

by

Donald Leslie Finch
Lieutenant Commander, United States Navy
B.S.E.E., Purdue University, 1965

Submitted in partial fulfillment of the
requirements for the degree of

MASTER OF SCIENCE IN AERONAUTICAL ENGINEERING

from the
NAVAL POSTGRADUATE SCHOOL
March 1977

Author

Donald Leslie Finch

Approved by:

Donald M. Clayton

Thesis Advisor

Richard W. Bell

Chairman, Department of Aeronautics

Robert A. Johnson

Dean of Science and Engineering

ABSTRACT

A personalized system of instruction utilizing self-contained text material and combining the principle of auto-tutorial instruction with modified self-pacing was developed for a course in aircraft performance. The course material, contained in Appendix A, was applied to the aircraft performance portion (six weeks) of a 12 week course in aircraft performance, control and stability taught to 11 students in the Department of Aeronautics at the Naval Postgraduate School, Monterey, California, during the summer quarter of 1976. The course results, summarized in Appendix B and C, tended to confirm the advantages and substantial value of this instructional method.

In addition, the course material will be utilized by the Office of Continuing Education, Naval Postgraduate School, Monterey, in its program of offering basic background courses off campus in preparation for graduate study.

TABLE OF CONTENTS

I.	ENGINEERING EDUCATION TODAY - - - - -	7
II.	ENGINEERING EDUCATION AT THE NAVAL POSTGRADUATE SCHOOL - - - - -	10
III.	PERSONALIZED SYSTEM OF INSTRUCTION - - - - -	15
IV.	THE CONTINUING EDUCATION PROGRAM - - - - -	19
V.	STUDY GUIDE DESCRIPTION AND USE - - - - -	22
VI.	ON CAMPUS APPLICATION OF PSI TO AIRCRAFT PERFORMANCE - - - - -	25
VII.	EVALUATION OF RESULTS - - - - -	27
VIII.	CONCLUSIONS AND RECOMMENDATIONS - - - - -	29
	APPENDIX A STUDY GUIDES - - - - -	32
	APPENDIX B STUDENT EVALUATION QUESTIONNAIRE - - - - -	400
	APPENDIX C SELECTED COMMENTS AND CRITIQUE - - - - -	405
	LIST OF REFERENCES - - - - -	409
	INITIAL DISTRIBUTION LIST - - - - -	411

ACKNOWLEDGEMENTS

The author wishes to express his appreciation to Associate Professor Donald M. Layton for his comments and suggestions as advisor to the author in the development of this thesis.

The author also wishes to express his appreciation to Mr. Thomas Moore and Mr. Robert Miller of the academic staff of the U. S. Naval Test Pilot School (TPS), Naval Air Test Center, Patuxent River, Maryland, for their instruction and their assistance in the compilation of TPS course material.

Lastly, the author would like to express his special thanks to his wife, Jonnie, for her diligent effort in the typing of thesis drafts but more importantly for her patience and understanding during the writing of this thesis.

I. ENGINEERING EDUCATION TODAY

Engineering education has undergone and continues to undergo dramatic changes in both methods and direction to meet the challenges of escalating complexity in today's environment. Engineering education, while meeting these challenges, must contend with rising costs, increasing public scrutiny and a downward trend in number of candidates. Engineering educators are now investigating new methods of instruction that make more efficient utilization of time for both the student and teacher while exploring new avenues to provide fresh insight into the student's engineering education.

The new changes and methods being pursued in today's engineering education are contrasted with the conventional lecture method. This venerable and current prevalent method involves an instructor who presents the course material through the media of the spoken word, using no materials or training aids other than a chalk board. This conventional lecture method usually has the following characteristics [Ref. 1]:

- a. The lecture is time-constrained by the standard scheduled period.
- b. The student is in a passive role and is expected to transcribe by notes, or otherwise record whatever information he deems essential.
- c. The pace is essentially fixed by the lecturer based on the scheduled contact hours/course coverage.

- d. There is virtually no "real-time" feedback. Due to the time constraints, questions or individual difficulties are usually deferred. This leads to the not unusual situation of the student missing vital succeeding concepts while momentarily pondering a puzzling point.
- e. The clarity of presentation is strongly dependent on the expository ability of the lecturer.

Each situation in which the lecture method is utilized may not contain each of the above characteristics exactly as described but nevertheless will contain some modification of these characteristics.

The prior use of the conventional lecturer method has been perpetuated for reasons which are often for administrative expediency at the sacrifice of quality of education. The conventional lecture method uses a rapid and inexpensive dispensing of information by the instructor with a minimum amount of equipment and materials. The actual receipt of this information by the student, however, is not guaranteed using the conventional lecture method. Additionally, the personal preferences of the lecturer can often bias the presentation of information to only those concepts which are academically convenient for the lecturer because of his background and experience.

Several varieties of non-lecture methods are currently being investigated by engineering educators as alternatives to the conventional lecture method. Nearly all of the methods are self-paced, incorporate the reinforcement theories first introduced by Sidney Pressey and B. F. Skinner [Ref. 2], and involve the use of a tutor. Engineering educators have found that one of the best methods to handle the

complex concepts involved in engineering is the method known
as "Personalized (or Proctorial) System of Instruction"

[Ref. 3].

II. ENGINEERING EDUCATION AT THE NAVAL POSTGRADUATE SCHOOL

In addition to the problems mentioned in Section I, engineering education at the Naval Postgraduate School, Monterey, California, faces unique restrictions not normally encountered at civilian institutions. These restrictions include dependence on Congressional allocation for school operating funds, unique educational requirements and utilization of officer graduates by the Navy, and constraints imposed on officer students by sea-shore rotation patterns and unpredictability of operational commitments.

As a result of Congressional action on the fiscal year 1974 Department of Defense Appropriation Bill, across-the-board reductions in funds for all services' graduate education programs have been made [Ref. 4]. Not only has an annual limitation now been placed on the number of officers each Service may have in graduate schools but there are now Congressional demands for further cost savings in these programs. Student enrollment statistics at the Naval Postgraduate School since the time of the first Congressional action shows its effects, with about 1000 students now enrolled as compared to a maximum of 1800 in 1971 [Ref. 5]. Not only has the enrollment been decreased in an effort to reduce cost, but the duration of an officer student's tour at the Naval Postgraduate School is being scrutinized.

The Select Study Committee Report of Navy Graduate Education Program for the Secretary of the Navy found that 70 percent of the total cost to the Navy of officer education is attributable to officer salary and permanent change of station (PCS) charges.

The unique educational requirements and utilization of officer graduates by the Navy call for a rigorous program of preparatory study in basic undergraduate level material at a time when a reduction in the officer student's tour at the Naval Postgraduate School is being emphasized. The Select Study Committee Report of Navy Graduate Education Program noted that the way in which the Navy manages its officer corps and utilizes its specialty and subspecialty talents place severe constraints on the educational alternatives that are available and have greatly influenced the development of non-traditional educational programs to their present stage. Studies indicate that as many as 50 percent of the incoming officers at NPS intended to enroll in curricula in which they did not have the prerequisites for direct admissibility to a graduate institution [Ref. 6]. In addition, students returning to NPS for formal advanced education may change from their original specialty field in order to fulfill Navy needs. As a result of the problem of varying knowledge, skill levels and diversity of background, a rigorous program of preparatory studies is required for a significant percentage of officer studies. The Select Study Committee found that there is a high probability that many

of these preparatory studies could be given in advance of attendance at NPS [Ref. 5].

The sea-shore rotations coupled with operational commitments place unique constraints on the availability of officer students. While the Congressionally-imposed student ceiling is a factor, the decline in the number of Naval officers entering graduate programs is due primarily to competing requirements to man fleet units and training activities while total Naval officer strength has been reduced [Ref. 4]. As Admiral J. S. Holloway, Chief of Naval Operations, has stated in Ref. 7:

"Operations at sea are conducted under unique conditions and require unique skills and knowledge. This, in turn, produces an important side effect that significantly affects the assignment of officers to postgraduate training and the subsequent utilization of their skills. The very fact that the professional Naval officer must be thoroughly familiar with the wide range of conditions encountered at sea locks him into a sea-shore rotation pattern that ultimately acts to constrain Naval educational programs in terms of opportunity, content, and duration."

To counter the unique constraints and restrictions placed upon engineering education at NPS, several prominent individuals and study groups have advocated the use of non-traditional education methods (PSI) and a continuing education program. The Department of Defense Committee on Excellence in Education recommended in Ref. 8 that, in order to reduce the time officers are in residence as students, the Continuing Education Program be continued and expanded. Upon a review of faculty utilization and productivity at the invitation of the Superintendent of NPS, Provost Emeritus F. E.

Terman, Stanford University, emphasized the use of innovative methods for education through the use of new technologies and ideas. Dr. Terman noted the prospects for the Personalized System of Instruction (PSI) in its application to graduate programs at NPS [Ref. 4]. The Navy Graduate Education Program Select Study Committee concluded that in order to decrease the time in residence for completing the preparatory work for a degree, thus reducing the total cost; and in order to increase the availability of education to a wider audience, thus serving more Navy officers; and to use more effectively the available resources of faculty and facilities, the following recommendations were made: [Ref. 5]

"The U. S. Navy strongly support continuing education as a primary function of the NPS, with appropriate budgetary support.

The NPS be designated as the center not only for residential graduate education, but also for developing off-campus non-traditional methods of instruction using innovative methods (such as PSI)."

In Ref. 4, the Department of Aeronautics at NPS was singled out for their use of PSI to reduce education costs by reducing time in residence. The Aeronautical Engineering curriculum preparatory phase was reduced to two quarters and was developed into the format of one-unit, self-study PSI modules. This PSI format permits the entry of students into the program at any time they can be ordered to NPS and allows the student to be scheduled to study the sequence of individual modules best suited to his intended area of specialization, proceeding initially at his own pace. The study guide

material found in Appendix A is currently being used in the Aeronautical Engineering curriculum preparatory phase in aircraft performance.

III. PERSONALIZED SYSTEM OF INSTRUCTION

There have been many variations of the non-lecture methods that have led to the development of the Personalized System of Instruction. The programmed text, the various teaching machines and computers are direct applications of the reinforcement theory but suffer from a relatively inflexible structure and tendency to design the instructor out of the picture. Engineering problem solving and design which uses cognitive strategy and complex concepts are not amenable to these constraints on structure and instruction. Closed circuit television, instructor and peer tutoring, visual aids, printed notes and outlines, while improving the lecture method, do not allow the student the basic need of proceeding at his own best speed. The evolution of the Personalized System of Instruction has resulted out of the deficiencies of the conventional lecture method and these various non-lecture alternatives.

Personalized instruction was first introduced in 1963 by two Brazilian teachers, Rodolpho Azzi and Carolina Martuscelli Bori, as a method of university instruction at the University of Brasilia [Ref. 9]. Professor F. H. Keller, Professor Emeritus of Psychology, Columbia University and Center for Personalized Instruction, Georgetown University, is generally regarded as the principal author of the present form of Personalized System of Instruction used in this country.

Professor Keller, who collaborated with Professors Azzi and Bori and Professor J. O. Sherman of Georgetown University, first described Personalized System of Instruction in his now classic paper found in Ref. 3 as follows:

1. The 'go-at-your-own-pace' feature, which permits a student to move through the course at a speed commensurate with his ability and other demands upon his time;
2. The unit-perfection requirement for advance, which lets the student go ahead to new material only after demonstrating mastery of that which preceded;
3. The use of lectures as vehicles of motivation, rather than sources of critical information;
4. The related stress upon the written word in teacher-student communication; and finally;
5. The use of proctors, which permits repeated testing, immediate scoring, almost unavoidable tutoring and a marked enhancement of the personal-social aspect of the education process.

The Personalized System of Instruction has been implemented by essentially every academic department at NPS for varying numbers of courses. The Office of Continuing Education, which is tasked with the overall coordination of PSI courses, has promulgated the following guidelines for the development of these courses:

1. The written word is used as the primary means of information transfer. There are few lectures, if any, in a PSI course.
2. The course material is divided into small units. A statement of behavioral learning objective is supplied for each unit.
3. The units are studied sequentially. The student must master each unit before proceeding to the next unit. Mastery is demonstrated by achieving a high score on a unit diagnostic test. If a student does not achieve the desired mastery score on a unit test,

there will be no penalty. He is told where he needs further study on that unit. He will take another test on the same unit at a later time. A final exam is given at the end of the course after all units have been completed.

4. A tutor (proctor on campus) is required to grade the unit exams and record the progress of each student. When a PSI course is delivered off campus the tutor will also answer questions normally answered by the instructor (professor) during on-campus courses.
5. The course is quasi self-paced. Some students will finish the units quickly; others will take longer. Some completion time limit is usually placed on each course.

The course materials for PSI courses at NPS usually contain a textbook (optional), a study guide, a course policy statement, unit diagnostic exams and a mid-term and final exam. For off-campus courses the tutor has, in addition to the above materials, a PSI tutor's manual, the unit diagnostic exam answers and answers to the study questions in the study guide.

Results of implementation of the Personalized System of Instruction have shown both problems and benefits of this method. The principal problems encountered are summarized as follows: [Ref. 10]

1. Logistic and administrative workload is increased.
2. Staff (proctor/tutor) is increased.
3. Class size for effective implementation is limited.
4. Procrastination by students creates problems for administration.

The benefits encountered are summarized as follows:

1. PSI is self-paced and is an efficient way to learn. (This is an important feature for students whose time is valuable.)

2. The highly organized nature of the course materials makes them an excellent source for review after course completion.
3. Utilization of the mastery concept builds confidence in the student and removes the fear of competition with one's peers.
4. The tutor/proctor can deal with individual difficulties which require personal attention.

Experience has shown that courses can be arranged to minimize the above problems and, when coupled with the above benefits, Personalized System of Instruction method results in increases in effectiveness of instruction. For a more detailed description of the Personalized System of Instruction, Ref. 9 is recommended.

IV. THE CONTINUING EDUCATION PROGRAM

The course material, contained in Appendix A, will be utilized by the Office of Continuing Education, Naval Postgraduate School, Monterey, in its program of offering a basic background course off campus in aircraft performance in preparation for graduate study.

The Continuing Education Program was established in June, 1974, as a means of providing extended educational services that include the offerings of credit courses off campus and the delivery, both on and off campus, of professionally relevant short courses. The basic background courses used in preparation for graduate studies are to be delivered off campus in a quasi self-instructional self-paced mode for the same academic credit as received when taken on campus. The short courses are designed to meet specific needs of operating units and for technical update of military and Department of Defense personnel with nationally recognized Continuing Education Units (CEU) awarded for their completion.

This self-instruction course, contained in Appendix A, will be delivered to officers at their current duty stations for completion during off duty hours of work/study periods. This course, prepared in accordance with the Personalized System of Instruction (PSI), has been selected primarily from course material normally taken in the initial phase of the Aeronautical Engineering Curricular program at the Naval

Postgraduate School. Its completion will reduce student time required in subsequent fully-funded graduate education programs.

The basic characteristics of the PSI method make this system readily adaptable for effective off campus instruction, since it is based primarily on the written rather than the spoken word for information transfer. The course study material is divided into six sequential individual units, and student progress is determined by mastery-level performance on unit diagnostic examinations. Diagnostic testing may be repeated without penalty until unit mastery has been demonstrated. The designated tutor will be available for tutorial assistance, will grade the unit examinations and will record the progress of each student. The provided course materials include the specific learning objectives and a policy statement which delineates the final examination policy and the performance required to earn specific grades. Final examinations will be administered on site by a third party and graded at the Naval Postgraduate School by the NPS professor who has overall responsibility for this course. Throughout this course, a communications arrangement will be available between the professor and the student-tutor team.

The Continuing Education Office will qualify individuals as designated Naval Postgraduate tutors and will maintain a current list of qualified military officers who have volunteered to serve in this capacity. A designated tutor is

provided with a comprehensive PSI tutor's manual to guide him in his efforts.

Application for enrollment in this self-instructional course may be made at any time by filling out the appropriate form from the Office of Continuing Education, Naval Postgraduate School. The application should be forwarded to Superintendent (Code 500), Naval Postgraduate School, via the command holding the applicant's service or personnel record in accordance with Ref. 11. The Naval Postgraduate School will maintain academic transcripts on all personnel who enroll in its Continuing Education credit courses and short courses.

V. STUDY GUIDE DESCRIPTION AND USE

The fundamentals of the Personalized System of Instruction were applied to a basic, introductory course in aircraft performance. The course material was devised to permit its use not only in off-campus work, but also as half of a one-quarter (12 weeks) course in performance and stability on-campus at NPS. The end results are contained in Appendix A and represent the major effort by the author in this thesis.

The course work is divided into six units. Each of these six units are subdivided into either two or three subunits. The major areas of material for each unit are as follows:

- a. Unit 1 - a basic introduction, the atmosphere, aircraft instrumentation.
- b. Unit 2 - aircraft drag, power required, and thrust required.
- c. Unit 3 - climb and descent performance.
- d. Unit 4 - range, cruise climb, and endurance.
- e. Unit 5 - maneuvering, instantaneous maneuverability and tactical performance.
- f. Unit 6 - take-off and landing performance.

In addition to these units, the study guide contains three appendices to facilitate in the student's preparation for and progress through the course work. A brief description of these appendices follows:

- a. Appendix I - tables of aerodynamic data
- b. Appendix II - a brief description of dimensional analysis

- c. Appendix III - a brief review of basic mechanics

Each student is provided a study guide for each unit of instruction on which he is working. The basic content of each study guide is as follows:

- a. Unit objectives - defined in terms of measurable behavior.
- b. Unit procedures - defined in terms of reading assignments, areas of concentration, and recommended study tactics for that particular unit.
- c. Unit study questions - defined in terms of discussion of the general philosophy and specific techniques of solution.
- d. Self-contained reading material - defined in terms of discussion of theoretical concepts and applications to specific situations.
- e. Unit supplementary problems - defined in terms of answers and guidance where necessary.

The reading material for these units is self-contained but the student should be urged to make use of any additional resource material that is available. A limited bibliography is listed at the beginning of Appendix A.

As a general manner of approach, the student should be urged to read the Statement of Objectives prior to reading the resource material. This will furnish an indication of what is to be expected from the unit. The student should then read the resource material twice; once rather rapidly in order to obtain the general knowledge of the contents, and then a second time more slowly looking for correlation with the objectives. After reading the assigned material, the student should attempt to answer the study questions without reference to the reading material. If only one or

two questions require reference to the reading material, it can be assumed that the student has a fairly good comprehension of the contents of the unit. If a greater number of questions can not be answered closed book, the student should re-read the assignment and then repeat the Study Questions.

After the study questions are answered, the student may wish to attempt the Supplementary Problems prior to taking the Unit Test. The Supplementary Problems serve two purposes; they provide additional reinforcement of key material in the Unit and they offer an opportunity for numerical solutions to what otherwise may be just statements of relationships.

If the student is unable to achieve mastery of the Unit Tests, he will be directed to review the Statement of Objectives, the resource material and the study questions and then to attempt another test on the same unit.

While time is not normally a dimension of PSI courses, there being neither pluses nor minuses for early or late work, in the on-campus environment there exists an implicit requirement to complete a given amount of work in a given time period so that the individual and the group may move on to other subjects. For this reason, it is to be expected that the on-campus student will average at least one unit completed per week. It is recommended that the off-campus student attempt a somewhat similar pace if possible.

VI. ON CAMPUS APPLICATION OF PSI
TO AIRCRAFT PERFORMANCE

The Department of Aeronautics at NPS, in order to permit entry of students into the Aeronautical Engineering curriculum at any point dictated by the operational needs of the Navy, has designed its preparatory phase into the format of one-unit, self-study PSI modules. The study guide material contained in Appendix A is currently being used in the Aeronautical Engineering curriculum preparatory phase in aircraft performance.

This introduction to aircraft performance is presented in two PSI courses titled AE 2305, Performance I, and AE 2306, Performance II. The first course, Performance I, AE 2305, consisting of Unit 1, Unit 2, and Unit 3, covers standard atmospheres, the altimeter, defined airspeeds, the airspeed indicator, machmeter, drag polar, flight polar, thrust and power required, climbing performance, ceilings, and range and endurance at constant altitude. The second course, Performance II, AE 2306, consisting of Unit 4, Unit 5, and Unit 6, covers cruise climb characteristics for range and endurance, energy management, turns, pull-ups, V-n diagram, take-off and landing performance. There is one hour credit given for the completion of each course.

In the development of these study guides, not only was compatibility with the continuing education program considered

but compatibility with the academic quarter system used on-campus at NPS was also considered. These study guides were to be used in the first half of a 12 week course in aircraft performance, control and stability. While retaining the self-paced, self-guided feature of the Personalized System of Instruction, each of the six instruction units was designed to be finished at the average rate of one unit per week. The student's pace needed to be controlled in the long term sense to ensure the class was prepared to start the second half of the course (control and stability) at approximately the same time. The second half of the course was taught in a quasi-PSI, conventional lecture method. Therefore, a recommended scheduling of the self-paced unit check tests was given to each student.

Two other modifications to the Personalized System of Instruction were made to accommodate the on-campus course. The mid-term and final examinations were made optional, with the course grades being assigned on the basis of number of successful completions of unit quizzes in comparison with the number of unit quizzes attempted. This modification was suggested by the instructor and agreed upon by the students. Additionally, group tutoring sessions, requested by a majority of the students, were held by the instructor on points of particular difficulty or complexity. These group tutoring sessions were in addition to the individual tutoring by the proctor and the instructor.

VII. EVALUATION OF RESULTS

In order to evaluate the relative effectiveness of the PSI Study Guides developed in this thesis, a comparison between a class of students taught by an instructor using the conventional lecture method and a class of students taught in the Personalized System of Instruction method during the summer quarter of 1976 was attempted. Students in the conventional lecture classes were asked for their opinions of their comprehension and retention of the course material and were additionally quizzed verbally by the author on key points in the course material. Due to lack of statistical significance of any data involving this group, grade comparisons were considered to have little meaning. The students in the PSI class were given a comprehensive student questionnaire administered at the end of the PSI portion of the course and were critiqued as a group by the author on all facets of the course. In the opinion of the author, there was a better overall comprehension of course material by the student in the PSI class as determined by student critiques and interviews.

The student questionnaire, contained in Appendix B, was administered to each student in the PSI class. Several important issues concerning the PSI method were noted. The numerical average of the student responses was tabulated in the enclosed boxes shown with each question. The student's

apparent high regard for the various facets of the Personalized System of Instruction are noted along with their opinion of other aspects of the administration of the course.

Representative comments from the student questionnaire along with comments from the critique session tended to corroborate the numerical results of the questionnaire and are contained in Appendix C.

VIII. CONCLUSIONS AND RECOMMENDATIONS

The subjective evaluations of the students involved in the PSI course in aircraft performance (Appendix B and Appendix C), the demonstrated compatibility of the PSI method of instruction with the Aeronautical Engineering curriculum, along with the proven success of other PSI courses at NPS tend to confirm the advantages and substantial value of the Personalized System of Instruction as an efficient and effective method of instruction. While some modifications to the pure PSI methods were made in the initial offering of the aircraft performance course, the majority of the students involved indicated a relatively greater effort was exerted and a deeper understanding of the course material was obtained by having been taught in the PSI method.

The PSI method has demonstrated the needed flexibility to permit entry of students into the Aeronautical Engineering curriculum at any time they can be ordered to NPS. The PSI method has also demonstrated the ability to allow the scheduling sequence of individual unit modules best suited to the student's intended area of specialization. The initial results of the PSI courses have indicated that students generally complete the Aeronautical Engineering curriculum preparatory phase in a shorter time than was true under the conventional lecture method. The PSI method holds the promise of reducing education costs by utilization of

the Continuing Education Program off-campus and by reduction of time in residence on campus.

It is recommended that the aircraft performance segment of the aircraft performance, control and stability course continue to be taught in the PSI mode. It is recommended that the use of a proctor, drawn from one of the students who has successfully completed the course, in addition to the assigned instructor, be continued. It is recommended that the tutor be compensated by an appropriate amount of academic credit for the undertaking of this task.

It is recommended that the student questionnaire, contained in Appendix B, be applied to the students currently being taught in the aircraft performance course in the Winter Quarter 1976-1977. At the present instructor's prerogative, the course, while using a portion of the study guides contained in Appendix A, is being taught in a quasi PSI-conventional lecture method without the use of a proctor. The compilation of student evaluations would serve as a useful comparison between the PSI method and the conventional lecture method. It is recommended that the resulting student critique and comments be used to further update and refine the study guides contained in Appendix A.

It is recommended that the user's feedback of the study guides be solicited from participants in the aircraft performance course offered off-campus by the Office of Continuing Education. The comments also could be used to update and refine the present form of the study guides.

Finally, it is recommended that the six-week control and stability segment of the on-campus aircraft performance, control, stability course be developed in the PSI mode. This development of the PSI method for the entire 12-week course would allow the self-pace aspect of PSI to be more fully explored.

APPENDIX A - STUDY GUIDES

The Study Guides developed for the introductory course in aircraft performance were designed to be used as a self-contained text. Source material used in this development can be found in Refs. 12-19. Students desiring a more in-depth study of the various topics contained in these Study Guides are referred to the above mentioned references. The Statement of Objectives was developed using methods found in Ref. 20.

AE-2305

PERFORMANCE I

UNIT 1

Introduction, The Atmosphere, Aircraft Instrumentation

AE 2305
PERFORMANCE I

Unit 1 - Introduction, The Atmosphere, Aircraft Instrumentation

OBJECTIVES

As a result of your work in this Unit, you should be able to:

1. List four properties of air used in constructing the ICAO Standard Atmosphere.
2. State the equation for a perfect gas.
3. List the ICAO Standard Sea Level Conditions.
4. Define geometric altitude, geopotential altitude and temperature altitude.
5. Derive an ICAO Standard Atmosphere table using the equation of state, temperature versus altitude relationship and sea level conditions.
6. Use an ICAO Standard Atmosphere table.
7. State the non-dimensional relationships for pressure, density and temperature ratios based on sea level conditions.
8. State the principle of operation of an altimeter and an airspeed indicator.
9. Define ground speed, Mach number, Equivalent air speed, Indicated air speed, and calibrated air speed, and relate these to True air speed.
10. Define and characterize stagnation pressure, static pressure and dynamic pressure.
11. Distinguish free-stream (ambient) pressure and velocity from local values about the aircraft.
12. Distinguish between the quantities $(q_c = P_T - P)$ and $(q = \frac{1}{2} \rho V^2)$.

AE 2305
PERFORMANCE I
Unit 1

PROCEDURE

1. Read sections 1-A, 1-B and 1-C.
2. Memorize equations (9), (17) and (21) in Section 1-C.
3. Review the Statement of Objectives.
4. Answer the Study Questions.
5. Review the resource material as necessary, based on your difficulty with the Study Questions.

When you are ready, ask for the written test on this Unit. This test will be Closed Book. If equations, other than those listed to be memorized, are required, they will be furnished.

AE 2305
PERFORMANCE I
Unit 1

STUDY QUESTIONS

1. In the ICAO Standard Atmosphere, how does temperature vary with altitude in the Troposphere?
2. Why are the relationships between density and pressure ratios different in the Troposphere and the Stratosphere?
3. How may an altimeter be used to indicate the true field altitude?
4. What parameter is corrected from standard conditions to ambient conditions in order to obtain Equivalent airspeed?
5. True air speed (Eq. 2, Section 1-C) depends on local values of pressure and density. If standard sea level values are used (as in an air speed indicator), what type of air speed is given?
6. When are Equivalent and True air speeds the same?
7. What is the speed of sound for a perfect gas?
8. What is the Equivalent air speed at an ICAO Standard Atmosphere geopotential altitude of 17,500 feet if the True air speed is 500 feet per second?
9. At the same altitude as Question 8, what is V_e if $V_T = 500$ knots?
10. In an ICAO Standard Atmosphere, if the pressure ratio is 0.73 and the density ratio is 0.84, what is the temperature in degrees Rankine?
11. The dynamic pressure (q) at sea level at $M = 1.0$ is 1481.2 lb/ft^2 . What Mach number is required at an ICAO geopotential altitude of 40,000 feet to produce the same dynamic pressure?

AE 2305
PERFORMANCE I
Unit 1

STUDY QUESTIONS - SOLUTIONS

1. In the Troposphere, temperature decreases linearly as altitude increases in the ICAO Standard Atmosphere.
2. In the Troposphere the pressure ratio divided by the density ratio is equal to the temperature ratio, which decreases as altitude increases. In the Stratosphere the pressure ratio divided by the density ratio is still the temperature ratio, but this ratio remains constant in the Stratosphere due to the constant temperature.
3. By setting the altimeter at the field barometric pressure.
4. True Airspeed.
5. Equivalent Airspeed.
6. When the ambient conditions are the same as the Standard Sea Level conditions.
7. $a = \sqrt{\gamma RT}$
8. 380.59 ft/sec
9. 380.59 kts
10. 450.68 °R
11. $M = 2.3$

UNIT 1-A
INTRODUCTION

1A-1 OPTIMIZATION

Implicit in the expression Aircraft Performance is the term 'Optimum'. It is not enough to calculate performance data or to attempt to use this data during flight unless the performance has been optimized. Inasmuch as manned aircraft have interfaces of the pilot actions, the airframe reactions and powerplant functions, the optimization must be, of a necessity, for the entire system and not any one of its integral parts.

Too often those with some parochial view of a single performance facet concern themselves with the maximization or minimization of one operational parameter without regard for the effect of this action on some concurrent or subsequent action. As an example of this, consider the take-off performance of an aircraft. Minimizing the take-off distance may be required if the runway is of limited length or if there is an obstacle to be cleared immediately after lift-off, but if minimum take-off run is considered to be the prime criteria in evaluating all take-off performance, additional requirements such as safe climb-out speed or minimum time to reach a certain altitude may be severely penalized.

Due to the departmentalized nature of the development of performance calculations to be presented, it may appear that each subsection stands on its own merits. The reader is cautioned, however, that the total performance problem requires many trade-offs in order that the overall performance calculations may approach the optimum.

1A-2 APPROXIMATIONS

Throughout, the reader will find many detailed equations which, with the proper inputs, will give precise results. This degree of accuracy is required in order to determine properly performance parameters, but in real life operational situations, one often finds that less precise information is available to the pilot, and indeed, considerably less accurate calculations may give quite realistic results. An example of this is the calculation of airspeed for some desired maneuver. Although it may be satisfying to those doing the calculations to obtain airspeed to three significant decimal places with a high confidence factor, the usefulness of this information to the pilot who can read his airspeed indicator only to within two to three knots is indeed suspect.

A useful approximation in performance calculations is derived from the Binomial Series expansion of a fractional exponent. Consider the series

$$(1 + x)^n = 1 + \frac{n}{1!} x + \frac{n(n-1)}{2!} x^2 + \frac{n(n-1)(n-2)x^3}{3!} + \dots \quad (1)$$

when $x = 0.40$, and $n = .10$

In this case, the third and subsequent terms are not only quite small, but also have alternating positive and negative signs and may be neglected with little loss in accuracy.

As an example of the use of this approximation, consider the problem where y is a function of the square root of z , and z is increased by ten percent.

$$y = (z)^{\frac{1}{2}} \quad (2)$$

$$y + \Delta y = (z + \Delta z)^{\frac{1}{2}} = \{(1 + 0.10)z\}^{\frac{1}{2}}$$

Using the first two terms of equation (1) with $x = 0.10$ and $n = \frac{1}{2}$

$$y + \Delta y = (1 + \frac{1}{2} \times 0.10)z \quad (3)$$

or,

$$y + \Delta y = (1.05)z^{\frac{1}{2}} = 1.05y \quad (4)$$

$$\Delta y = 0.05y \quad (5)$$

a check of the accuracy of this approximation may be made by rewriting equation (2) as

$$y^2 = z \quad (6)$$

$$(y + \Delta y)^2 = (1.05)^2 z = 1.1025z \quad (7)$$

the magnitude of the error is therefore 0.0025.

As will be demonstrated later, this approximation method is quite valuable in determining the velocity/weight relationship inasmuch as velocity varies with the square root of the weight.

1A-3 STANDARDS

Performance calculations are much more meaningful if comparisons can be made with other configurations of the same aircraft or with other aircraft. For this reason it is essential that all calculations be referred to a common base. This may be done by using dimensionless coefficients as in the case of Lift and Drag, or by correcting all data to some generally accepted base. The use of a Standard Atmosphere, as discussed in Unit 1-B, is an example of the latter, as is the reference to such items as Wing Loading (aircraft weight divided by the area of the main wing surface), and the weight/density ratio

(W/δ) used in Drag calculations.

Performance calculations for a single aircraft under different loading conditions, power output, Drag variant configurations, et cetera, may be standardized by referring each in turn to a standard weight, power, Drag, et cetera. This permits ready evaluation of different conditions by a simple comparison of results. It is to be recognized however that once data is reduced to a standard, this data is no longer applicable to the specific set of conditions under which it was obtained.

1A-4 UNITS AND DIMENSIONS

All physical quantities may be expressed in terms of four basic dimensions. These are mass (M) , length (L) , time (T) , and temperature (Θ) . The units used in aeronautics for these dimensions are, in order, the slug, the foot, the second, and the degree Centigrade or the degree Kelvin. The slug is that mass which, when acted on by a force of one pound weight, has an acceleration of one foot per second per second. One slug is equivalent to 32.174 pounds mass. The degree Kelvin is identical with the degree Centigrade, but is measured from the absolute zero of temperature whereas the Centigrade scale is measured (has its zero value) from the freezing point of water. Temperature in Centigrade is equal to the temperature in Kelvin minus 273.

The basic dimensions may be used in a dimensional analysis (see Dimensional Analysis, Appendix II), to determine the unknown dimensions of a quantity if this quantity can be related to units that have a known dimension. For example, distance has the dimension of length (L). Speed, which is distance per unit time, has the dimensions of (LT^{-1}) and acceleration, which

is speed per unit time has the dimensions of (LT^{-2}) . Since force is equal to mass times acceleration,

$$\text{Force} = M \times LT^{-2} = MLT^{-2} \quad (8)$$

it can be seen that force has the dimensions of (is measured in) slugs feet per second per second.

Conversion factors permit the use of other than the basic dimensions in calculations. Speed, which is measured in feet per second, may be converted to miles per hour by multiplying by 60 x 60 (seconds per hour) and dividing by 5280 (feet per mile). Similarly, by multiplying by 60 x 60 (seconds per hour) and dividing by 6000 (feet per nautical mile), speed may be expressed in terms of nautical miles per hour (knots).

It is good engineering practice to include all of the units for each value in a calculation in order to insure that the solution has the proper units.

1A-5 CONVERSION FACTORS

Any engineering handbook will contain conversion factors that will enable the user to make rapid conversions from one set of units to another. Some of the more commonly used factors applicable to performance calculations are contained in Table 1-1.

TABLE 1-1

Conversion Factors

<u>Multiply</u>	<u>By</u>	<u>To Obtain</u>
Feet per minute	0.01667	Feet per seconds
	0.00987	Knots
	0.01137	Miles per hour
Feet per second	0.59208	Knots
	0.68182	Miles per hour
Horsepower	33000.	Foot-pounds per minute
	550.	Foot-pounds per second
Knots	1.68894	Feet-per second
	1.15155	Miles per hour
Miles	5280.	Feet
	0.86839	Nautical Miles
Miles per hour	88.	Feet per minute
	1.4667	Feet per second
	0.86839	Knots
Miles per hour squared	2.15111	Feet per second squared
Pounds per square inch	0.06805	Atmospheres
	2.03601	Inches of Mercury
Radians	57.29580	Degrees (angle)
Radians per second	9.54930	Revolutions per minute
	0.15916	Revolutions per second

UNIT 1-B

THE ATMOSPHERE

1B-1 THE ATMOSPHERE

The performance of aircraft is seriously affected by the atmospheric conditions in which they operate and these conditions are constantly changing. Performance data obtained in a particular set of atmospheric conditions is therefore meaningless unless this data can be correlated with other conditions. In order to compare performance data, the effects of the atmosphere must either be removed or corrected to some standard. Although the standards are much more meaningful if they approximate existing conditions, purely arbitrary standards may be used, provided that all calculations are referred to the same standard base.

The earth's atmosphere has been generally divided into four regions because of the variance of conditions in each of the regions. The Troposphere, closest to the earth, is the atmospheric region in which most clouds are formed and in which the air movement (winds) is characterized by turbulence. The height of the Troposphere extends from about five miles at the poles to about ten miles at the equator. Another characteristic of the Troposphere is that the ambient temperature generally decreases as one goes from the surface to the limits of the Troposphere (the Tropopause). This decrease in temperature with altitude is called the Lapse Rate, and is, on the average, fairly constant, although at any given time the temperature change rate may be less or greater (called an inversion) than the average.

From the upper limits of the Troposphere to approximately sixty miles above the surface of the earth is the region called the Stratosphere. High velocity winds may be found in this region, but these winds are generally steady in nature. The temperature in the Stratosphere remains effectively constant because this region is above the radiant heating from the earth and is protected by the upper ionization layers from the direct heating from the sun.

The Ionosphere, which extends from the upper limits of the Stratosphere (the Stratopause) upwards to approximately 300 miles, is characterized by electrical phenomena both visible (aurora borealis) and invisible (ionization). In this region the temperature increases with altitude to as much as 4000 °F at the upper limits.

The fringe region of the earth's atmosphere extends from the Ionopause upwards to about 600 miles. In the Exosphere the air is so rarified as to offer negligible resistance to the passage of an object.

1B-2 STANDARD ATMOSPHERE - IACO STANDARD ATMOSPHERE

In order to provide a meaningful base for the comparison of aerodynamic parameters, various standard atmospheric models have been constructed. The National Advisory Committee for Aeronautics (NACA), the predecessor of the National Aeronautics and Space Administration (NASA), created and published such a set of standards in 1922 in their Report 218. Variations of this set of "standards" were derived by various agencies throughout the world and were published as NACA Standard Summer Day, NACA Standard Winter Day, Air Force Summer Atmosphere, et cetera. In 1952 the International Civil Aviation Organization (ICAO) published a "Manual of the ICAO Standard Atmosphere"

which was adopted and published by the NACA as Report 1235 in 1955.

The ICAO Standard Atmosphere was based on average, annual values observed at about Latitude 40° in North America up to an altitude of about 20,000 meters (65,617 ft). Standard sea level values were designated (Table 1B-1) and the following assumptions were made:

- a. The air is dry and homogeneous
- b. The equation of state (perfect gas law) applies

$$p = gR' \rho T \quad \text{or} \quad p = R \rho T \quad (1)$$

where

$$g = 32.174 \text{ ft/sec}^2$$

$$R' = 53.35 \text{ ft/}^\circ\text{Rankine or } 96.04 \text{ ft/}^\circ\text{Kelvin}$$

The product of $gR' = R$ is frequently used where

$$R = 1716.55 \text{ ft}^2/\text{sec}^2 \text{ }^\circ\text{Rankine}$$

- c. Hydrostatic equilibrium exists

$$dp_a = - g \rho dH \quad (2)$$

where

$$p_a = \text{ambient atmospheric pressure}$$

$$dH = \text{change in geopotential height}$$

- d. The measure of vertical displacement is geopotential. Geopotential is the measure of gravitational potential energy of a unit mass at a point relative to sea level. Geopotential is defined by the equation

$$G dH = g dh \quad (3)$$

where

G = a dimensional constant, $32.174 \text{ ft}^2/(\text{sec-geopot. ft})$

H = Geopotential at the point, geopotential feet

g = acceleration due to gravity, ft/sec^2

h = Geometric (tapeline) altitude above mean sea level, feet

The concept of geopotential height is used to accommodate the potential energy of a body when it is raised some distance above the earth due to the change in gravitational pull. For example, a unit mass with zero potential energy (at mean sea level) when raised to a geometric altitude, h , does not have an increase of potential energy equal to the product of the weight times the geometric altitude, (Wh) , due to the fact that the weight of the unit mass is less at the altitude because of the decrease in gravitational force. To achieve the proper potential energy on the basis of sea level gravity, the unit mass would have to be raised to a slightly higher altitude (geometric altitude).

Variations in geopotential and geometric altitudes are shown in Appendix I, Table 1.

e. Temperature variations with geopotential is expressed as a series of straight lines. From sea level to 11,000 meters (36,089 feet) the temperature change is $-0.001981 \text{ }^\circ\text{C}/\text{geopotential foot}$, and from 11,000 meters to approximately 25,000 meters (about 80,000 feet) the temperature is assumed to remain constant at $-56.5 \text{ }^\circ\text{C}$ ($-69.7 \text{ }^\circ\text{F}$).

Below 36,089 feet

$$T = T_{\text{ssl}} - a H$$

where

a = Temperature Lapse Rate

Above 36,089 feet

$$T = \phi \quad (\text{Constant})$$

For the assumed straight line variations in temperature and the temperature - density - pressure relationships of equations (1) and (2), pressure and density may also be expressed in terms of geopotential height. For the mathematical derivation of these relationships, refer to NACA Report 1235.

A sketch of temperature, pressure and density as a function of geopotential altitude, with the standard sea level values as shown in Table 1B-1, is shown in Figure 1B-1.

TABLE 1B-1
ICAO STANDARD ATMOSPHERE
STANDARD SEA LEVEL VALUES

Pressure	2116.222 lb/ft ²
Temperature	518.688 °R (15 °C)
Density	0.0023769 lb sec ² /ft ⁴
Sonic Velocity	1116.89 ft/sec

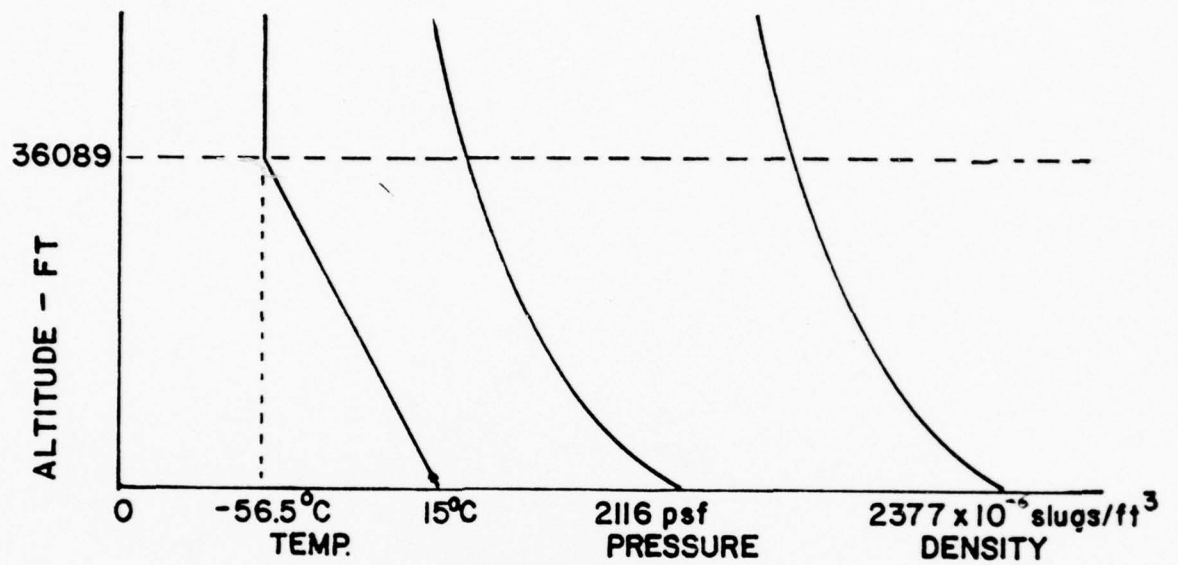

ICAO ATMOSPHERE
FIG. IB-1

For computational ease, ratio values are frequently used in listing temperature, density and pressure. These ratios are based on standard sea level values

Temperature Ratio	$\theta = T/T_{ss1}$
Density Ratio	$\sigma = \rho/\rho_{ss1}$
Pressure Ratio	$\delta = p/p_{ss1}$

Representative ICAO Standard Atmosphere values are given in Appendix I, Table 2.

1B-4 STANDARD ATMOSPHERE - U.S. STANDARD ATMOSPHERE SUPPLEMENTS, 1966

The U.S. Standard Atmosphere Supplements, 1966 were prepared under the sponsorship of the Environmental Services Administration, National Aeronautics and Space Administration and the United States Air Force. In order to prepare more meaningful atmospheric tables, rather than just arbitrary standards, the COESA Working Group developed models of the atmosphere for altitudes up to 120 kilometers for five geographical regions:

Tropic (15° N), annual average up to 120 km.

Subtropic (30° N), January and July to 80 Km and winter and summer 80 to 120 km.

Mid-latitude (45° N), January and July to 80 km and winter and summer 80 to 120 Km.

Subarctic (60° N), January and July to 80 km and winter and summer 80 to 120 km.

Arctic (75° N), January and July to 30 km.

Representative values of the Mid-latitude, Spring/Fall atmosphere are shown in Appendix I, Table 3. It is to be noted that the U.S. Standard Atmosphere Supplements, 1966 has listings for both geopotential and geometric altitudes in both english and metric units.

1B-5 STANDARD ATMOSPHERE - USSR

Technical Reports and articles from the USSR indicate that the Soviet Union is using a Time Standard Atmosphere (TSA-60) circa 1960 based on the same temperature lapse rate as the ICAO Standard.

1B-6 USE OF THE TABLES

Inasmuch as the preponderance of the current aeronautic literature on aircraft performance is based on the ICAO Standard Atmosphere (textbooks, reports, NATOPS, et cetera), these tables (Appendix I, Table 2) will be used during this course.

The fact that we have a standard atmosphere leads to several other terms with which the reader should be familiar. They are pressure altitude, density altitude, and temperature altitude. These words are meaningless unless a standard atmosphere is implied (in our case the ICAO standard) and are defined as follows:

H_p , pressure altitude is that geopotential altitude in a standard ICAO atmosphere where a particular pressure may be found.

H_ρ , density altitude is that geopotential altitude in a standard ICAO atmosphere where a particular density may be found.

H_t , temperature altitude is that geopotential altitude in a standard ICAO atmosphere where a particular temperature may be found.

From the above definitions, it may be seen that pressure altitude, density altitude, and temperature altitude do not define altitudes but rather define pressure, density, or temperature. When any two are given, the third may be determined through the equation of state.

As an example of the use of the Standard Atmosphere Tables, let us look at a sample problem:

For a pressure of 1124 lb/ft^2 and $\theta = 0.9$, determine the pressure, density and temperature altitude. Why are they different?

For a pressure of 1124 lb/ft² the pressure ratio is

$$\delta = \frac{P_a}{P_{ssl}} = \frac{1124 \text{ lb/ft}^2}{2116.216 \text{ lb/ft}^2} = 0.5311$$

from Table 2, Appendix I, for a pressure ratio of 0.5311 the (geopotential) pressure altitude is

$$H_p = 16,500 \text{ ft}$$

For a temperature ratio of $\theta = 0.9$, directly from the Table

$$H_t = 14,500 \text{ ft}$$

From the perfect gas law (Equation 1)

$$\rho = \frac{P}{R T}$$

where $P = 1124 \text{ lb/ft}^2$ and $T = T_o \theta = 518.688 (0.9) = 466.8 \text{ }^\circ\text{R}$
therefore,

$$\rho = \frac{1124 \text{ lb/ft}^2}{(1716.55 \text{ ft}^2/\text{sec}^2 \text{ }^\circ\text{R}) (466.8 \text{ }^\circ\text{R})}$$

$$\rho = 0.0014026$$

and

$$H_\rho = 16,950 \text{ ft} \quad (\text{From the Table, using } \sigma)$$

These altitudes are different because the given parameters are different from a standard day atmosphere.

Unit 1-C

Aircraft Instrumentation

1C-1 THE MEASUREMENT OF AIRSPEED

An accurate knowledge of the airspeed and altitude of an aircraft is very important in flight evaluation - not only in the area of performance but also in stability and control testing. Due to the fact that the aircraft velocity is used to non-dimensionalize all the stability and control derivatives. Many methods have been used to determine airspeed and they range from listening to the sound of the wind through the wires in open-cockpit aircraft to the present pitot-static systems. The pitot-static system has proved to be reliable, simple and accurate both for the measurement of airspeed, altitude, vertical velocity and Mach number. Present day pitot-static systems have changed very little throughout the years except for the fact that the pressure outputs which were and still are on many aircraft, connected directly to the instruments where mechanical linkages transform the pressure readings to direct readings of airspeed and altitude. These systems now use pressure transducers which convert the pressure readings to an electrical signal which drives, via small computing circuits, the pointers on the instruments. Airspeed indicators are actually differential pressure gauges calibrated according to the law of frictionless adiabatic flow, presuming that the ambient conditions are those of the standard atmosphere at sea level. At subsonic speeds, Bernoulli's compressible equation for frictionless isentropic flow may be expressed as

$$p_t - p_a = p_a \left\{ \left(1 + \frac{\gamma-1}{2} \left(\frac{v_t}{a} \right)^2 \right)^{\frac{\gamma}{\gamma-1}} - 1 \right\} \quad (1)$$

where p_t = Free stream total pressure
 p_a = Free stream static pressure
 γ = ratio of specific heats (c_p/c_v)
 V_t = True airspeed
 a = local atmospheric speed of sound = γRT

Solving equation (1) for V_t gives

$$V_t = \left\{ \frac{2RT\gamma}{\gamma-1} \left[\left(\frac{p_t - p_a}{p_a} + 1 \right)^{\frac{\gamma-1}{\gamma}} - 1 \right] \right\}^{1/2} \quad (2)$$

Expanding the right side of equation (1) in a binomial series as a function of Mach Number ($M = v_t/a$) and solving for the ratio of total to ambient pressures

$$\frac{p_t}{p_a} = 1 + \frac{\gamma M^2}{2} + \frac{\gamma M^4}{8} + \frac{\gamma M^6}{80} + \frac{\gamma M^8}{3200} + \dots \quad (3)$$

The difference between the free stream total and static pressure ($p_t - p_a$) is referred to as the compressible dynamic pressure, or the impact pressure (q_c). At very low subsonic airspeeds this impact pressure which is felt at stagnation points is equal to dynamic pressure (q)

$$q = \frac{1}{2} \rho_a V_t^2 \quad (4)$$

As the speed of the moving bodies is increased, the effects of compressibility are felt and the impact pressures (q_c) at the stagnation points becomes greater than the dynamic pressures (q)

If the ambient density in equation (4) is converted to the product of standard sea level density (ρ_{ssl}) and density ratio (σ),

$$q = \frac{1}{2} \rho_{ssl} \sigma V_t^2 \quad (5)$$

Using the equation of state for ambient conditions, solving for T_a and substituting in Equation (2)

$$V_t = \left\{ \frac{2\gamma p_a}{(\gamma-1)\rho_a} \left[\left(\frac{p_t - p_a}{p_a} + 1 \right)^{\frac{\gamma-1}{\gamma}} - 1 \right] \right\}^{1/2} \quad (6)$$

1C-2 CALIBRATED AIRSPEED

If standard sea level values are substituted for ambient pressure and density in Equation (6), except for the pressure difference term, the calibration equation for an airspeed indicator is obtained in which the only variables are ($p_t - p_a = q_c$) and all other quantities on the right side are constants. The airspeed indicator is therefore a differential pressure gauge whose internal algebraic manipulations provide the necessary relationships between p_{ssl} , and ρ_{ssl} .

$$V_c = \left\{ \frac{2\gamma p_{ssl}}{(\gamma-1)\rho_{ssl}} \left[\left(\frac{p_t - p_a}{p_{ssl}} + 1 \right)^{\frac{\gamma-1}{\gamma}} - 1 \right] \right\}^{1/2} \quad (7)$$

1C-3 EQUIVALENT AIRSPEED

At sea level on a standard day $p_{ssl} = p_a$ and $\rho_{ssl} = \rho_a$ and the calibrated airspeed indicator reads true airspeed. If, however, ambient pressure (p_a) were used instead of sea level pressure (p_{ssl}) the result is equivalent

airspeed (V_e) . The correction from V_c to V_e is commonly called the compressibility correction.

$$V_e = \left\{ \frac{2 p_a}{(\gamma-1)\rho_{ssl}} \left[\left(\frac{p_t - p_a}{p_a} + 1 \right)^{\frac{\gamma-1}{\gamma}} - 1 \right] \right\}^{1/2} \quad (8)$$

If Equation (6) is divided by equation (8):

$$\frac{V_t}{V_e} = \left(\frac{\rho_{ssl}}{\rho_a} \right)^{1/2} = \sigma = \frac{-1}{2} \quad (9)$$

Equation (5) may therefore be rewritten as

$$q = \frac{1}{2} \rho_{ssl} V_e^2$$

1C-4 AIRSPEED CORRECTIONS

In addition to the corrections required to go from calibrated airspeed (V_c) to equivalent airspeed (V_e) to true airspeed (V_t), two other corrections are required in performance flight testing; (1) the instrument correction which is applied to the value observed by the pilot (V_o) in order to obtain indicated airspeed (V_i), and (2) the position error correction which is applied to indicated airspeed (V_i) in order to obtain calibrated airspeed (V_c). The instrument correction takes care of those errors between what is introduced to the airspeed indicator and what is presented to the pilot. These errors include such items as inaccuracies due to wear and tear during the airspeed indicator's usage and manufacturing tolerances. The position error correction accounts for those errors induced

by the field of flow about the aircraft. Position errors are further discussed later in this section.

A summary of airspeed corrections is as follows:

$$V_{\text{observed}} + \Delta V_{\text{instrument}} = V_{\text{indicated}} \quad (11)$$

$$V_{\text{indicated}} + \Delta V_{\text{position}} = V_{\text{calibrated}} \quad (12)$$

$$V_{\text{calibrated}} + \Delta V_{\text{compress.}} = V_{\text{equivalent}} \quad (13)$$

$$V_{\text{equivalent}} + \Delta V_{\text{density}} = V_{\text{true}} \quad (14)$$

1C-5 THE ALTIMETER

The altimeter is, perhaps, the simplest of the instruments used in performance testing. In order to read pressure altitude on the instrument, it is merely necessary to furnish p_a to the instrument as an input and then design the instrument to indicate altitude in accordance with the relationship between geopotential altitude and pressure used in the ICAO standard atmosphere. Furnishing the exact value of p_a as an input is somewhat difficult and errors in measurement of p_a must be corrected. These position errors will be discussed later. Manufacturing an instrument to follow the variation of pressure with altitude in the ICAO atmosphere is not particularly difficult, but some means must be provided to allow for the variation of pressure from standard conditions at various altitudes. The altimeter setting window resulted. When one wishes to read pressure altitude one must have standard sea level pressure set in the window (29.92"Hg). It is interesting to note that most altimeters are constructed in such a manner that the altimeter setting does not affect the relationship of pressure input and altitude indication of the instrument.

1C-6 AMBIENT AIR TEMPERATURE

Ambient air temperature (t_a) is an extremely important variable in performance testing. It is not particularly difficult to measure unless extreme accuracy is required. To measure ambient air temperature an outside air temperature gauge is used. The reading on an outside air temperature gauge is related to ambient air temperature by the following equation:

$$\text{OAT} = t_a \left(1 + \frac{\gamma-1}{2} K M^2 \right) \quad (15)$$

where K is called the recovery factor. If OAT and M are recorded and K is known one can solve this equation directly for t_a , which can be converted to T_a . The solution of this equation has been presented in graphical form below. If K is not known but is assumed to be invariant with ambient temperature and M , t_a can be determined if OAT is recorded at two values of M . By plotting OAT vs M^2 and extrapolating the data to $M^2 = 0$, t_a may be determined.

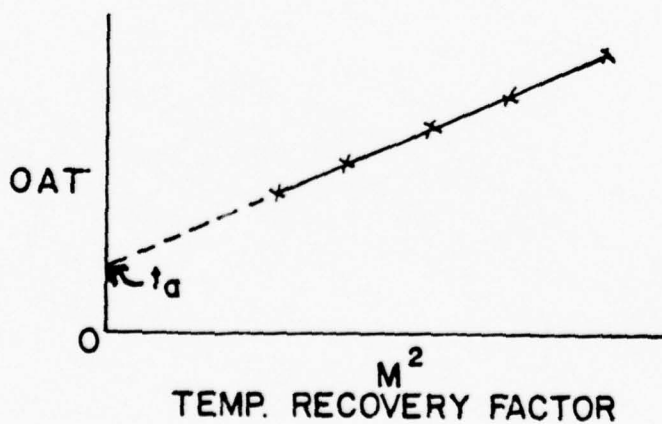

FIG. 1C-1

In recent years considerable work has been done to develop a temperature indicating system which will read ambient temperature directly, in other words a system which has a zero recovery factor. Such systems are available and are referred to as vortex thermometers.

1C-7 MACH NUMBER

Mach Number is the ratio of the true airspeed of the airplane to the speed of sound in the atmosphere through which the airplane is flying,

$$M = V_T / a$$

The speed of sound is determined by

$$a = \sqrt{\gamma R T_a} \quad (17)$$

where T_a is the absolute ambient temperature of the air through which the airplane flies. There is a popular misconception that temperature must be known in order to accurately measure Mach Number. This is not true. Mach Number may be determined from pressure measurements alone. However, temperature measurements in conjunction with Mach Number are required in order to determine true airspeed. Substituting Equations (16) and (17) in Equation (2) we have

$$M^2 = \frac{2}{\gamma-1} \left[\left(\frac{P_t - P_a}{P_a} + 1 \right)^{\frac{\gamma-1}{\gamma}} - 1 \right] \quad (18)$$

or

$$M = \left\{ \frac{2}{\gamma-1} \left[\left(\frac{P_t - P_a}{P_a} + 1 \right)^{\frac{\gamma-1}{\gamma}} - 1 \right] \right\}^{1/2} \quad (19)$$

All quantities on the right side of equation 19 are constants with the exception of p_t and p_a . If these two quantities are measured and fed into an instrument which performs the algebraic manipulations indicated by the equation which is used in the manufacture of Machmeters. This is a pressure ratio instrument and Mach Number may be determined as accurately as the manufacturer can construct the instrument and as accurately as one can measure p_t and p_a .

Without an actual Machmeter one can determine Mach Number if V_c and H_p can be measured. Equation 7 shows that a value of $p_t - p_a = (q_c)$ will define a calibrated airspeed value and vice versa. H_p , as has been previously pointed out, is merely a measurement of pressure. q_c and p_a on the other hand define a Mach Number by equation 19. It is possible then to construct curves of V_c , M and H_p where any one quantity may be determined if the other two are known. Such charts are usually used to determine Mach Number knowing V_c and H_p .

Machmeters, being pressure ratio instruments, require accurate pressure inputs. If the pressure inputs are inaccurate, faulty Mach readings will result. Machmeters, like airspeed, indicators and altimeters, are subject to position errors.

1C-8 DYNAMIC PRESSURE (q) AND IMPACT PRESSURE (q_c)

Dynamic pressure, q , which we find involved in all considerations of drag and lift of airplanes in flight, is defined as

$$q = \frac{1}{2} \rho_a V_t^2 \quad (20)$$

If the right side of the equation is multiplied and divided by ρ_{ssl} (a constant equal to $.002377 \text{ slugs/ft}^3$).

$$q = \frac{1}{2} \rho_{ssl} \frac{\rho_a}{\rho_{ssl}} V_t^2$$

and since $\frac{\rho_a}{\rho_{ssl}} = \sigma$

$$q = \frac{1}{2} \rho_{ssl} \sigma V_t^2$$

and since $\sigma V_t^2 = V_e^2$

$$q = \frac{1}{2} \rho_{ssl} V_e^2 = \gamma p_a M^2 \frac{1}{2} \quad (21)$$

Since ρ_{ssl} is merely a constant, we see that q is irrevocably tied to equivalent velocity, V_e . When a value of V_e is given, a value of q is implied and vice versa. Tables can be made up giving values of q for values of V_e . These may be found in any of the aerodynamic handbooks. The tabulations are valid under all atmospheric conditions and for any vehicle.

Dynamic pressure was probably first used and defined by one of the Bernoulli brothers. (Total pressure is composed of static pressure and dynamic pressure). In their day of very low speeds, the dynamic pressure (q) and the impact pressure (q_c) felt at stagnation points on bodies moving through air were essentially identical. As the speeds of moving bodies increased, the effects of compressibility came into play and impact pressures (q_c) felt at stagnation points became appreciably greater than the dynamic pressures. The impact pressure (q_c) felt at stagnation points is the total pressure, p_t , less the ambient pressure, p_a , ($p_t - p_a$) and as has been previously pointed out, is called compressible q or q_c . We have also seen that a particular value of q_c is irrevocably tied to a particular value of V_c by our airspeed

calibration equation (7). Once again, tables may be found of particular value of q_c for particular value of V_c in aerodynamic handbooks. These tabulations also are valid for any atmospheric conditions and for any vehicle.

What is the exact relationship between q and q_c ? Let us examine

$$\frac{p_t}{p_a} = 1 + \frac{\gamma M^2}{2} + \frac{\gamma M^4}{8} + \frac{\gamma M^6}{80} + \frac{\gamma M^8}{3200} + \dots$$

Then

$$p_t = p_a + \frac{\gamma p_a M^2}{2} + \frac{\gamma p_a M^4}{8} + \frac{\gamma p_a M^6}{80} + \frac{\gamma p_a M^8}{3200} + \dots \quad (22)$$

We have defined:

$$q = \frac{1}{2} \rho_a V_T^2 = \frac{1}{2} \rho_{ssl} V_e^2 \quad (23)$$

Substituting for ρ_a from the equation of state:

$$q = \frac{\gamma p_a V_T^2}{2 R T_a}$$

And since:

$$\begin{aligned} \gamma R T_a &= a_2^2 \\ q &= \frac{\gamma p_a M^2}{2} \end{aligned} \quad (24)$$

substituting equation 24 into equation 22:

$$p_t = p_a + q \left(1 + \frac{M^2}{4} + \frac{M^4}{40} + \frac{M^6}{1600} + \dots \right)$$

We have previously said that

$$p_t - p_a = q_c$$

Then:

$$q_c = q \left(1 + \frac{M^2}{4} + \frac{M^4}{40} + \frac{M^6}{1600} + \dots \right) \quad (25)$$

We will call the series in brackets in equation 25 $f(M)$. Then

$$q_c = q f(M) \quad (26)$$

For low values of M , $q_c = q$.

However, as Mach Numbers increases, q_c becomes appreciably greater than q (For $M = 0.6$, $f(M) = 1.093$) .

Thus we see that the stagnation pressures exerted on bodies flowing through air are greater by $[f(M) - 1]$ than the dynamic pressure. The forces exerted on the body, it follows, are also greater than those predicted by assuming air to be incompressible. However, the science of aerodynamics had developed along incompressible lines for so many decades that the many definitions of coefficients such as C_D , C_L , C_M , etc, based on q , rather than q_c , were universally accepted as definitions. As Mach Numbers increased, but were still lower than the critical Mach Number for a particular body, it was natural that the increase in forces on the bodies should be attributed to Mach effects. Thus we see different curves for C_L vs α for different Mach Numbers commencing at values of M lower than those where Mach Number affects the flow. At still higher Mach Numbers the true flow effects of Mach Number are encountered.

1C-9 POSITION ERROR

Position errors occur because the pressures registered by the pitot-static system differ from the free stream pressures because of the existence of other than free stream pressures at the pressure source and/or errors in the local

pressure at the source which is caused by the pressure sensors.

In subsonic flight, the flow perturbations due to the aircraft static pressure field are nearly isentropic in nature and do not effect the total pressure. Except at extreme angles of attack, as long as the total pressure source is located in an undisturbed area (i.e., out of the wing or propeller wake, out of the boundary layer, out of the region of localized supersonic flow), the total pressure error will usually be negligible. Particularly in performance flight testing, an aircraft capable of supersonic speeds should have a boom-mounted pitot-static system so that the total pressure pickup will be located ahead of any shock waves formed by the aircraft.

The static pressure field surrounding an aircraft in flight is a function of speed, altitude, angle of attack, Reynolds number and Mach Number. It is therefore rarely possible to locate the static source in a location where free stream static pressure will be sensed under all flight conditions. As a result of this, static pressure position error will generally exist.

A presentation of airspeed and altimeter position errors is shown below for the T-38 aircraft. (Configuration PA-gear and flaps down; configuration CR-gear and flaps up).

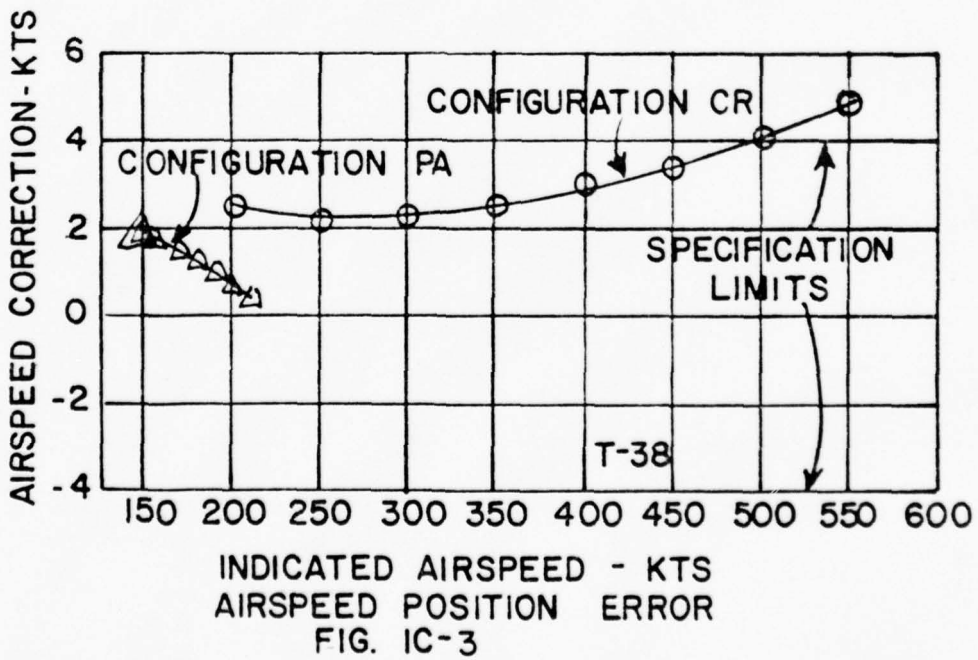
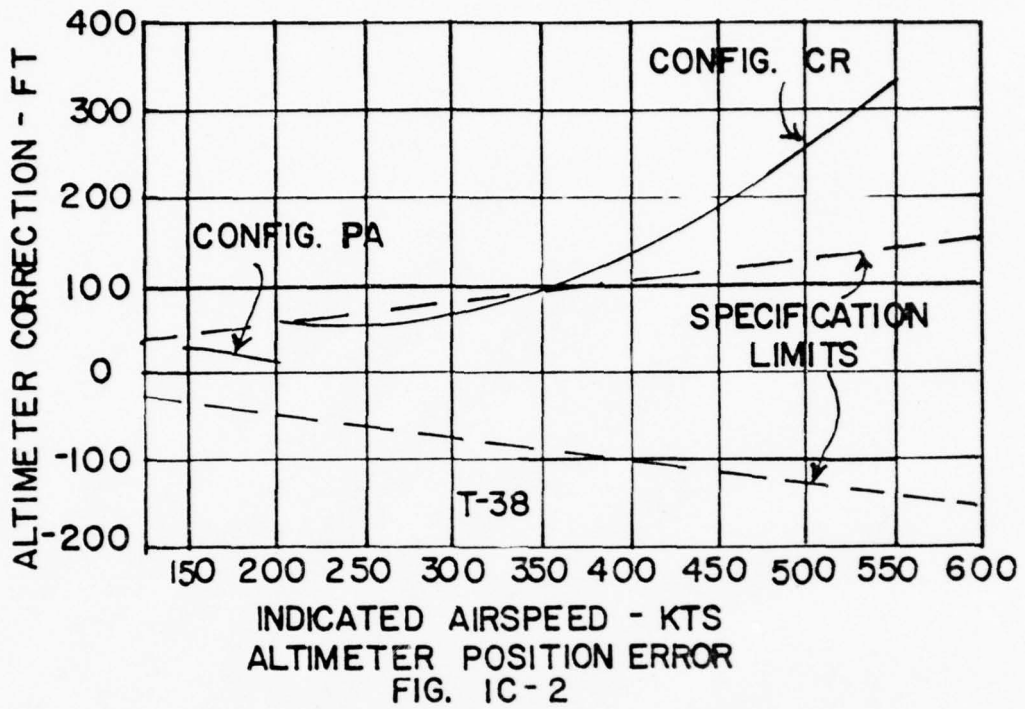

1C-10 PRESSURE LAG CORRECTION

One additional error correction is of a dynamic nature. The pressure lag error exists only when the aircraft in which the instruments are installed is changing airspeed or altitude. In this case there is a time lag between such time as the pressure change occurs and when it is indicated on the instrument dial. Pressure lag is basically a result of:

1. Pressure drop in the tubing due to viscous friction.
2. The finite speed of pressure propagation. (Acoustic lag)
3. Inertia of the air mass in the tubing.
4. Instrument inertia and kinetic friction.

A detailed discussion of pressure lag may be found in NACA Report Number 919.

1C-11 TRANSONIC AND SUPERSONIC POSITION ERRORS

In transonic flight there may be a shock wave ahead of both the total and static sources, between the two sources, or aft of both sources. The position of the shock wave in relation to the total and static sources will seriously affect the inputs to each. In supersonic flight there will be a shock wave ahead of both sources. The total pressure (p_t) ahead of the shock wave is greater than the total pressure behind the shock wave, and the static pressure (p_a) in front of the shock wave is less than the static pressure behind the shock wave. The magnitude of the differences will depend on the position of the measurement sources in relation to the shock wave and the type of shock wave will depend upon the operational Mach Number and the geometry of the body. It is difficult to generalize about the position errors associated with transonic and supersonic flight, but these errors must be accounted for in any performance flight test.

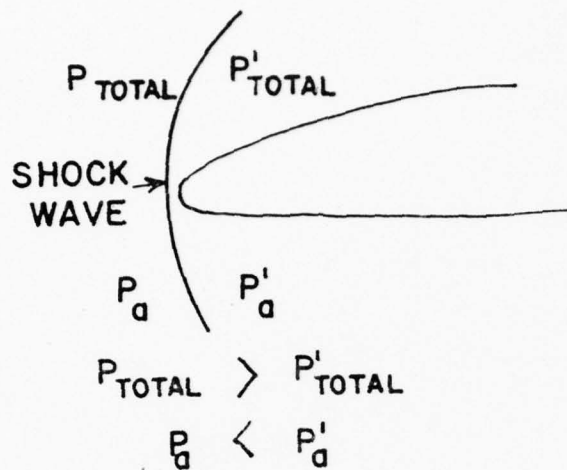

FIG. 1C-4

1C-12 SUMMARY OF UNIT 1

In summary we have seen that the ICAO standard atmosphere is that used by the United States and all other NATO countries. This atmosphere provides an arbitrary standard atmospheric basis to which performance data may be reduced for comparative purposes.

The following functional relationships were developed and discussed. Each functional relationship is, of course, different.

$$V_c = f(q_c) \tag{7}$$

$$V_e = f(V_c, H_p) = f(q_c, H_p) \tag{8}$$

$$V_t = V_e \sqrt{\sigma} \tag{9}$$

$$OAT = f(T_a, M) \tag{15}$$

$$M = f(q_c, H_p) \quad P = f(V_c, H_p) \tag{19}$$

$$q = f(V_e) = \frac{1}{2} \rho_{ssl} V_e^2 \tag{23}$$

$$q_c = f(q, M_{\text{series}}) \quad (26)$$

$$V_T = f(M, T_a) = f(V_e, H_p, T_a) \quad (16)$$

SUPPLEMENTARY PROBLEMS

Unit 1

1. For a thermally perfect gas at constant density, doubling the temperature (degrees Fahrenheit) results in:
 - a. Halving the pressure
 - b. Doubling the pressure
 - c. Increase of pressure by a factor of $\sqrt{2}$
 - d. None of the above
2. The temperature in degrees Rankine is approximately the temperature in degrees Fahrenheit plus 460. With a temperature lapse rate of -3.566 °F/1000 feet, the temperature at 10,000 feet is:
 - a. 93.7 °F
 - b. 22.9 °F
 - c. 35.7 °F
 - d. -10.3 °F
3. If the temperature ratio (θ) is 0.82 and the pressure ratio (δ) is 0.34, what is the density in an ICAO Standard Atmosphere?
4. For the conditions in Problem 3 above, what is the pressure altitude?
5. For a pressure altitude of 18,000 feet and a temperature of 15 °F, what is the ICAO temperature altitude?
6. For the conditions of Problem 5 above, what is the density altitude?
7. In the Stratosphere, what is the relationship between density ratio (σ) and the pressure ratio (δ)?
8. The speed of sound at sea level (standard conditions) is approximately 1116 ft/sec. If the temperature ratio at altitude is 0.25, the speed of sound at that altitude is:
 - a. 279 ft/sec
 - b. 4464 ft/sec
 - c. 558 ft/sec
 - d. 2232 ft/sec
9. The relationship between True air speed and Equivalent air speed ($V_T \sqrt{\sigma} = V_{EAS}$) is valid for:
 - a. Only the incompressible case
 - b. Only the compressible case
 - c. Only when the ambient density equals the standard sea level density
 - d. Both the compressible and incompressible cases

SUPPLEMENTARY PROBLEMS

Unit 1

(Cont)

10. At sea level, with no instrument, compressibility or position errors, the air speed that the pilot sees on his air speed indicator is:
 - a. Always less than True air speed.
 - b. The same as Equivalent air speed.
 - c. Always greater than the True air speed.
 - d. Usually less than the Equivalent air speed.
11. At an altitude of 10,000 feet, with no instrumentation, compressibility or position errors, the air speed that the pilot sees on his air speed indicator is:
 - a. Always less than the Equivalent air speed.
 - b. Always greater than the True air speed.
 - c. The same as the Equivalent air speed.
 - d. Usually greater than the Equivalent air speed.

SUPPLEMENTARY PROBLEMS

SOLUTION SHEET

UNIT 1

1. For a thermally perfect gas, the pressure is equal to the product of the Gas Constant, the density and the absolute temperature

$$P = R \rho T \quad \text{Eq. (1), 1-B}$$

therefore

$$\frac{P_1}{P_2} = \frac{\rho_1}{\rho_2} \cdot \frac{T_1}{T_2}$$

and with constant density ($\rho_1 = \rho_2$)

$$\frac{P_1}{P_2} = \frac{T_1}{T_2}$$

Doubling the absolute temperature doubles the pressure, but doubling the temperature in degrees Fahrenheit will not.

The answer is:

d. None of the above

2. The ICAO Standard Sea Level temperature in degrees Fahrenheit is the Standard temperature in degrees Rankine minus 460

$$T_{ss1} = (518.59 \text{ } ^\circ\text{R} - 460) \text{ } ^\circ\text{F} = 58.59 \text{ } ^\circ\text{F}$$

With a lapse rate of $-3.566 \text{ } ^\circ\text{F}/1,000 \text{ ft}$, at 10,000 feet the temperature has decreased by $35.66 \text{ } ^\circ\text{F}$. The temperature is therefore

$$T_{10,000} = (58.59 - 3.566 \times 10,000) = 23.93 \text{ } ^\circ\text{F}$$

The answer is:

b. 22.9 °F

3. Pressure ratio equals the product of the density ratio and the temperature ratio

$$\delta = \sigma \times \theta \quad \text{Eq. (1), 1-B}$$

The density ratio is therefore

$$\sigma = \frac{\delta}{\theta} = \frac{0.34}{0.82} = 0.41$$

The density is the product of the density ratio and the sea level density

$$\underline{\rho} = \sigma \times \rho_{ss1} = 0.41 \times 0.0023769 = \underline{0.0009745 \text{ slugs/ft}^3}$$

SUPPLEMENTARY PROBLEMS

SOLUTION SHEET

UNIT 1

(Cont)

4. Table 2 of Appendix I shows that at a pressure ratio of 0.3398, the pressure altitude is 27,000 geopotential feet

The answer is:

$$\underline{H_p = 27,000 \text{ ft}}$$

5. At a temperature of 15 °F, the absolute temperature is approximately (460 + 15) °R = 475 °R. The temperature ratio is therefore

$$\theta = \frac{475 \text{ } ^\circ\text{R}}{518.89 \text{ } ^\circ\text{R}} = 0.9159$$

From Table 2 of Appendix I, the following values are read:

Altitude	θ
12,000 ft	0.9175
12,500 ft	0.9141

In this range, the change of θ with H is

$$\frac{\Delta\theta}{\Delta H} = \frac{(0.9175 - 0.9141)}{(12,000 - 12,500)} = -6.8 \times 10^{-6}/\text{ft}$$

(Note the minus sign indicates a decrease in θ with an increase in altitude).

The actual temperature ratio is $\theta = 0.9159$. The difference between this ratio and the ratio at 12,000 ft is

$$\Delta\theta' = (0.9159 - 0.9175) = -0.0016$$

therefore,

$$\Delta H' = \Delta\theta' / (\Delta\theta / \Delta H) = -0.0016 / (-6.8 \times 10^{-6}) = 235 \text{ feet}$$

and $\underline{H_T = 12,000 + 235 = 12,335 \text{ ft}}$

6. $\theta = 0.9159$ (from Problem 5) and $\delta = 0.4993$ (from Table 2) since $\delta = \sigma \times \theta$

$$\sigma = \frac{0.4993}{0.9159} = 0.5451$$

Interpolation of the values in Table 2 (in a manner as shown in Problem 5) shows that at $\sigma = 0.541$

$$\underline{H_e = 19.326 \text{ ft}}$$

SUPPLEMENTARY PROBLEMS

SOLUTION SHEET

UNIT 1

(Cont)

7. In the Stratosphere the temperature remains a constant, therefore the temperature ratio remains a constant. Since

$$\delta = \sigma \times \theta = \sigma \times \text{a constant}$$

$$\delta/\sigma = \text{a constant}$$

8. From Eq. (7), i-C, the speed of sound is $a = \sqrt{\gamma RT}$ or

$$a = \sqrt{1.4 \times 1716.55 \times T} \quad \text{ft/sec} = 49\sqrt{T} \quad \text{ft/sec}$$

For a temperature ratio of 0.25, the speed of sound is

$$a = 49\sqrt{(518.89 \times 0.25)} = \underline{558 \text{ ft/sec (c.)}}$$

9. Equivalent air speed is the velocity computed on the basis of sea level density, while True air speed is computed on the basis of ambient (local) density. Dynamic pressure is

$$q = \frac{1}{2} \rho_a V_T^2 = \frac{1}{2} \rho_{ssl} V_e^2$$

This is the actual dynamic pressure (q) for both the compressible and the incompressible cases. The impact pressure may vary, but the dynamic pressure remains the same. The answer is d. Both the compressible and incompressible cases.

10. With no instrument errors, the Observed air speed is equal to the Indicated air speed (Eq. (11), 1-C). With no position error, the Indicated air speed is equal to the Calibrated air speed (Eq. (12), 1-C), and with no compressibility correction, the Calibrated air speed is equal to the Equivalent air speed (Eq. (13), 1-C). Therefore, what the pilot sees is Equivalent air speed. The answer is

b. The same as Equivalent air speed

11. At altitude, all of the conditions of Problem 10 are still valid. At sea level the Equivalent air speed is equal to the True air speed (Eq. (14), 1-C), but what the pilot sees at altitude is still Equivalent air speed. The answer is:

c. The same as Equivalent air speed.

AE-2305

PERFORMANCE I

UNIT 2

Drag, Power Required, Thrust Required

Unit 2 - Drag, Power Required, Thrust Required

OBJECTIVES

As a result of your work in this Unit, you should be able to:

1. Write a general equation for the total drag coefficient for a parabolic drag polar.
2. Express drag as a function of velocity for a parabolic drag polar.
3. State the lift-to-drag ratio for minimum drag and show where this occurs on a drag versus velocity plot.
4. Give the relationship between parasite drag coefficient and induced drag coefficient at the point of minimum.
5. Discuss the effect of weight changes on the shape of the drag polar and on the changes in velocity for minimum drag.
6. Discuss the effect of changes in parasite drag coefficient on the shape of the drag polar.
7. Explain how drag changes with altitude on a drag- True air speed plot.
8. State the relationships between drag, thrust required and power required.
9. Express the lift-to-drag ratio for minimum power required and show graphically where this occurs on a power versus velocity plot and on a thrust versus velocity plot.
10. Express power required as a sum of two velocity-related terms.
11. Express thrust required as a sum of two velocity-related terms.

AE 2305
PERFORMANCE I
Unit 2

PROCEDURE

1. Read Sections 2-A and 2-B.
2. Memorize equation (7) in Section 2-A and equations (6), (10) and (12) in Section 2-B.
3. Review the Statement of Objectives.
4. Answer the study questions.
5. Review the resource material as necessary, based on your difficulty with the Study Questions.

When you are ready, ask for the written test on this Unit. This test will be Closed Book. If equations, other than those listed to be memorized, are required they will be furnished.

AE 2305
PERFORMANCE I
Unit 2

STUDY QUESTIONS

1. Why is the drag polar for an ideal airplane parabolic?
2. Prove that the minimum drag for an ideal airplane occurs at the intersection of the induced and parasite drag curves. (Hint: at minimum drag, $dD/dV = 0$)
3. The drag coefficient for an aircraft is expressed as

$$C_D = 0.04 + 0.08 C_L^2$$

What is the coefficient of lift at the minimum drag point?

4. For the same aircraft as in Question 3, if the wing lift efficiency factor (e) is 0.8, what is the Aspect Ratio?
5. Since power (in ft-lb/sec) is equal to thrust (lb) times velocity (ft/sec), what is the general equation for power as a function of velocity?
6. What is the relationship between parasite drag and induced drag at the point of minimum power?
7. What is the effect of an increase in aircraft weight on the parasite drag? On the induced drag?
8. What is the effect of increasing altitude (decreasing density) on the plot of thrust required versus True air speed? On the plot of thrust required versus Equivalent air speed?
9. What are the limitations on a plot of thrust required versus True air speed as to weight, altitude and configuration of the aircraft?
10. What is the effect of an increase in altitude on a plot of power required versus True air speed?

AE 2305
PERFORMANCE I
Unit 2

STUDY QUESTIONS - SOLUTIONS

1. C_{D_p} is a constant and $C_{D_i} = f(C_L^2)$

2. $D = K_1 V^2 + K_2/V^2$

$$\frac{dD}{dV} = 2 K_1 V - 2 K_2/V^3 = 0 \quad \text{and} \quad 2 K_1 V = 2 K_2/V^3$$

multiplying both sides by $V/2$

$$K_1 V^2 = K_2/V^2 \quad \text{or Parasite Drag equals Induced Drag}$$

3. $C_L = 0.04/0.08)^{1/2} = 0.07$

4. $1/\pi A R e = 0.08$, therefore $AR = 1/(\pi \times 0.8 \times 0.008) = 5.0$

5. $T = K_1 V^2 + K_2/V^2$ and Power = $T \times V$

$$\text{therefore, Power} = (K_1 V^2) \times V + (K_2/V^2) \times V = K_1 V^3 + K_2/V$$

6. $C_{D_i} = 3 C_{D_o}$ (See Fig. 2B-4)

7. Parasite drag does not change. Induced drag increases.

8. The curve moves along a constant thrust curve tangent to the minimum thrust required line.

9. One weight, one altitude, one configuration.

10. Moves curve along a line from the origin tangent to the curve. (See Fig. 2B-8).

GLOSSARY OF TERMS

- a - Subscript used to denote ambient conditions
- α - Angle of attack
- AR - Aspect ratio $\frac{(\text{Wing Span}^2)}{\text{Wing Area}}$
- C_D - Coefficient of Drag
- C_L - Coefficient of Lift
- C_{D_i} - Coefficient of Induced Drag
- D - Drag
- D_p - Parasite drag
- D_i - Induced drag
- e - Lift efficiency factor
- hp - Pressure altitude
- $K_1 K_2$ - Constants, may have different values depending on equation involved
- L - Lift
- M - Mach number
- μ - Viscosity
- P - Pressure
- R_n - Reynold's number
- ρ - Density
- S - Surface area
- $\sigma = \frac{\rho_a}{\rho_{SSL}}$
- SSL - Subscript denoting standard sea level
- T - Thrust
- T_a - Ambient temperature

V - Velocity
V_C - Calibrated velocity
V_e - Equivalent velocity
V_T - True velocity
W - Weight

2A-1 DRAG POLARS

A drag polar is simply the relationship between the airplane's drag coefficient (C_D) and lift Coefficient (C_L). The following discussion will briefly outline the origin of the terms (C_D , C_L , M , R_n) and then review some actual airplane drag polars. The objective is to develop a "model" drag polar which will be the basis for much of the theory used in the performance course.

A dimensional analysis of the following variables

$$L = f(\rho, P, V, \mu, S, \alpha) \quad (1)$$

yields the following functional relationship

$$C_L = f(\alpha, M, R_n) \quad \text{Assume } S = \ell \text{ or } S = f(\alpha, M) \quad (2)$$

Likewise, a similar analysis of the drag variables

$$D = f(\rho, P, V, \mu, S, \alpha) \quad (3)$$

yields

$$C_D = f(\alpha, M, R_n) \quad S = \ell \text{ or } S = f(\alpha, M) \quad (4)$$

Equation 2 can be rearranged and written as

$$\alpha = f(C_L, M, R_n) \quad (5)$$

and then substituted into equation 4 to give

$$C_D = f(C_L, M, R_n) \quad \begin{array}{l} S = \ell \\ \text{or } S = f(\alpha, M) \\ \text{or } S = f(C_L, M) \end{array} \quad (6)$$

The final result of the dimensional analysis (Equation 6) indicates that the drag coefficient (C_D) is dependent on the lift coefficient, Mach number and Reynolds number. The following are some considerations of the results:

The final results (Eq - 6) is a more compact statement of the original statements (Eq -1 and 3). Equations 1 and 3 were just statements of what we "know" based on past observations. If we omitted an important variable in Eq -1 or 3, then there is no way that the dimensional analysis can introduce the important variable (s).

The dimensional analysis does NOT indicate any type of equation (e.g. linear, parabolic) relating C_D with C_L , M or R_n . Equations must come from a theory and/or experimental result(s).

The dimensional analysis has enabled us to efficiently describe the drag characteristic of an airplane... During flight test we can now document the drag characteristics in terms of only three parameters (Eq - 6) instead of the six variables as indicated in equation 3.

We will now look at some actual airplane drag polars. An equation or model for a drag polar is shown below

$$C_D = C_{D_0} + \frac{C_L^2}{\pi e AR} \quad (7)$$

Sketching of the above equation shows the effect of C_{D_0} and $1/eAR$ on the polar

where C_{D_0} = Drag coefficient at zero lift

e = Lift efficiency factor

AR = Aspect Ratio $\left(\frac{\text{Wing Span}^2}{\text{Wing Area}}\right)$

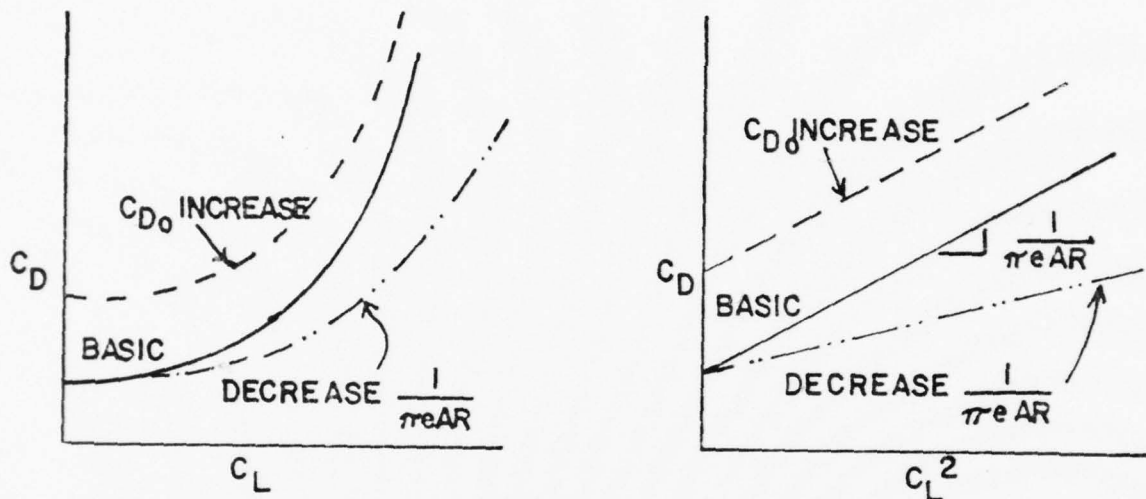

FIG. 2A-1

The above form of the drag polar (parabolic) suggests a convention for plotting experimental $C_D - C_L$ data. We see that if the drag data is plotted as $C_D = f(C_L^2)$ it will be linear if, in fact, the polar is parabolic. If the airplane's polar is of another form then the $C_D - C_L^2$ plot will not be linear.

Figures 2A-2 through 2A-7 present the drag polars of various airplanes at different flight conditions. Note that for any given Mach, the polars shown in Figure 2A-2 conform well to the parabolic form ($C_D = K_1 + K_2 C_L^2$). If we consider the slope (K_2) and the intercept (K_1) to be functions of Mach they would appear as shown in Figure 2 (recall that $K_1 = C_{D0}$ and $K_2 = \frac{1}{\pi e AR}$). The trends illustrated in Figures 2A-2 and 2A-3 are classic. That is ... $\frac{1}{\pi e AR}$

and C_{D_0} are constant in the low Mach range and then increase above a given Mach. The value of C_{D_0} and $\frac{1}{\pi eAR}$, along with the M where the curves bend, vary for different airplanes.

The "dirty" (gear and flaps down) polars (Figure 2A-4) for the same airplane can be considered to be parabolic over the mid C_L range but break upward at the low and high lift coefficients. We see that the configuration change effectively increased C_{D_0} but did not change the value of $1/\pi eAR$.

Figures 2A-5 and 2A-6 are included to illustrate the limitations of some of the assumptions we have made.

Figure 2A-5 illustrates the effect of power setting on the polar (a variable representing power setting was not included in the original dimensional analysis). Figure 2A-6 shows a polar that is definitely not of the form we assumed ($C_D = K_1 + K_2 C_L^2$). Figures 2A-5 and 2A-6 show that the model polar that we use is NOT always appropriate.

PROBLEMS: (2A-I)

(1) Fit an equation to that data of Figure 2A-6. Use a polar of the form

$$C_D = K_1 + K_2 C_L^n \quad \text{where } n \text{ is an integer}$$

(2) Determine the equation for the polar shown in Figure 2A-7. Assume a parabolic form.

(3) Given the following test data $S = 300 \text{ ft}^2$

	h_p (ft)	T_a (°C)	V_e (fps)	D (lbs)	L (lbs)	C_D	C_L	C_L^2
1	5,000	+9	150	1,274	10,000			
2	10,000	-5	200	1,156	9,500			
3	10,000	-6	300	1,781	9,000			
4	20,000	-23	400	2,947	8,800	.0517	.1543	.0238
5	20,000	-23	400	3,559	24,000	.0624	.4207	.1770
6	20,000	-24	800	15,190	30,000	.0666	.13148	.0173
7	40,000	-55	500	4,570	12,000	.0513	.1346	.0181

- Plot the drag polar $C_D = f(C_L^2)$
- Compare graphically determined values to compute values using

$$C_D = \frac{D}{qS} = \frac{D}{\frac{1}{2}\rho_{SSL} V_e^2 S} \quad \text{and} \quad C_L = \frac{L}{qS} = \frac{L}{\frac{1}{2}\rho_{SSL} V_e^2 S}$$

ANSWERS

	C_D	C_L	C_L^2
1	.1588	1.247	1.554
2	.0811	.6661	.4438
3	.0555	.2805	.0787

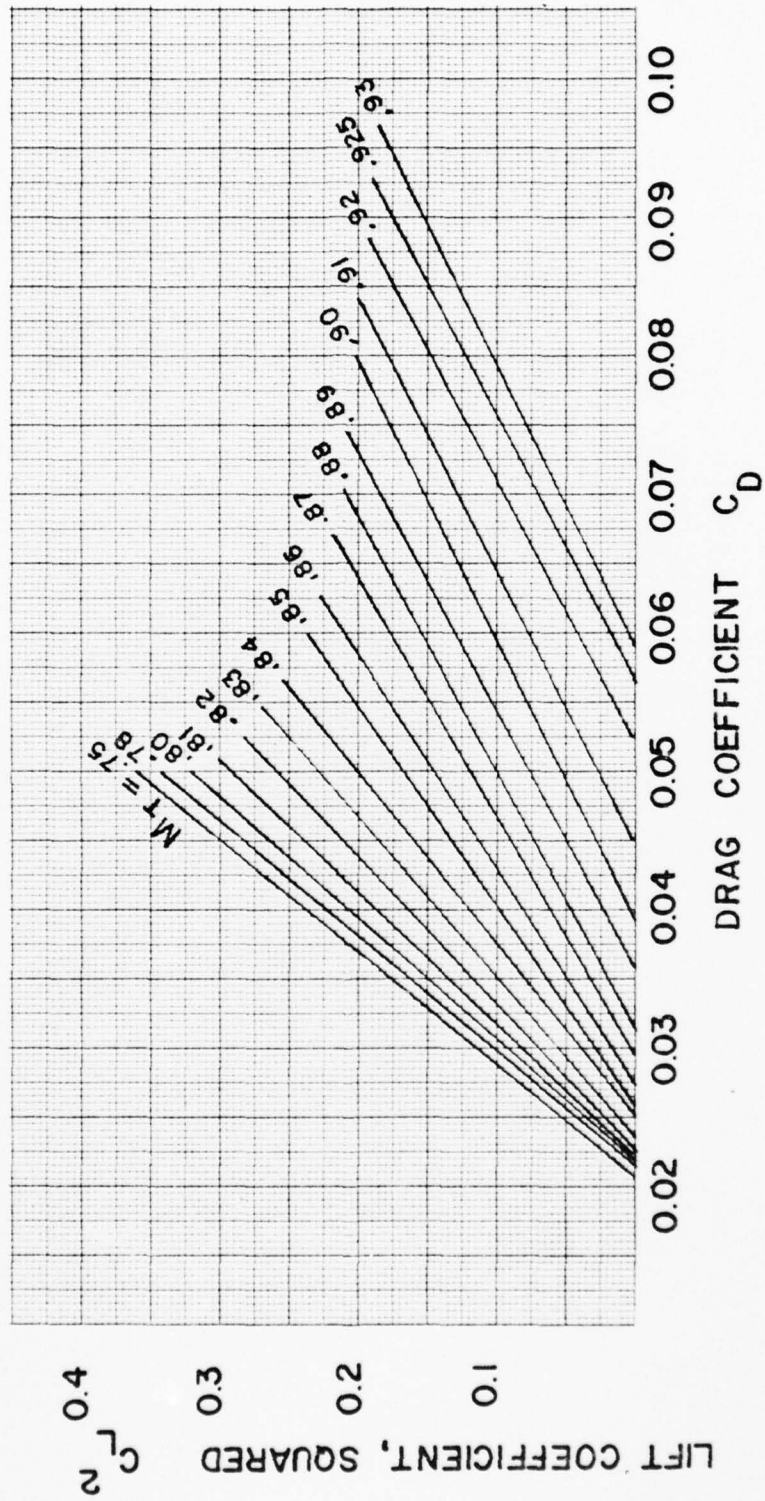
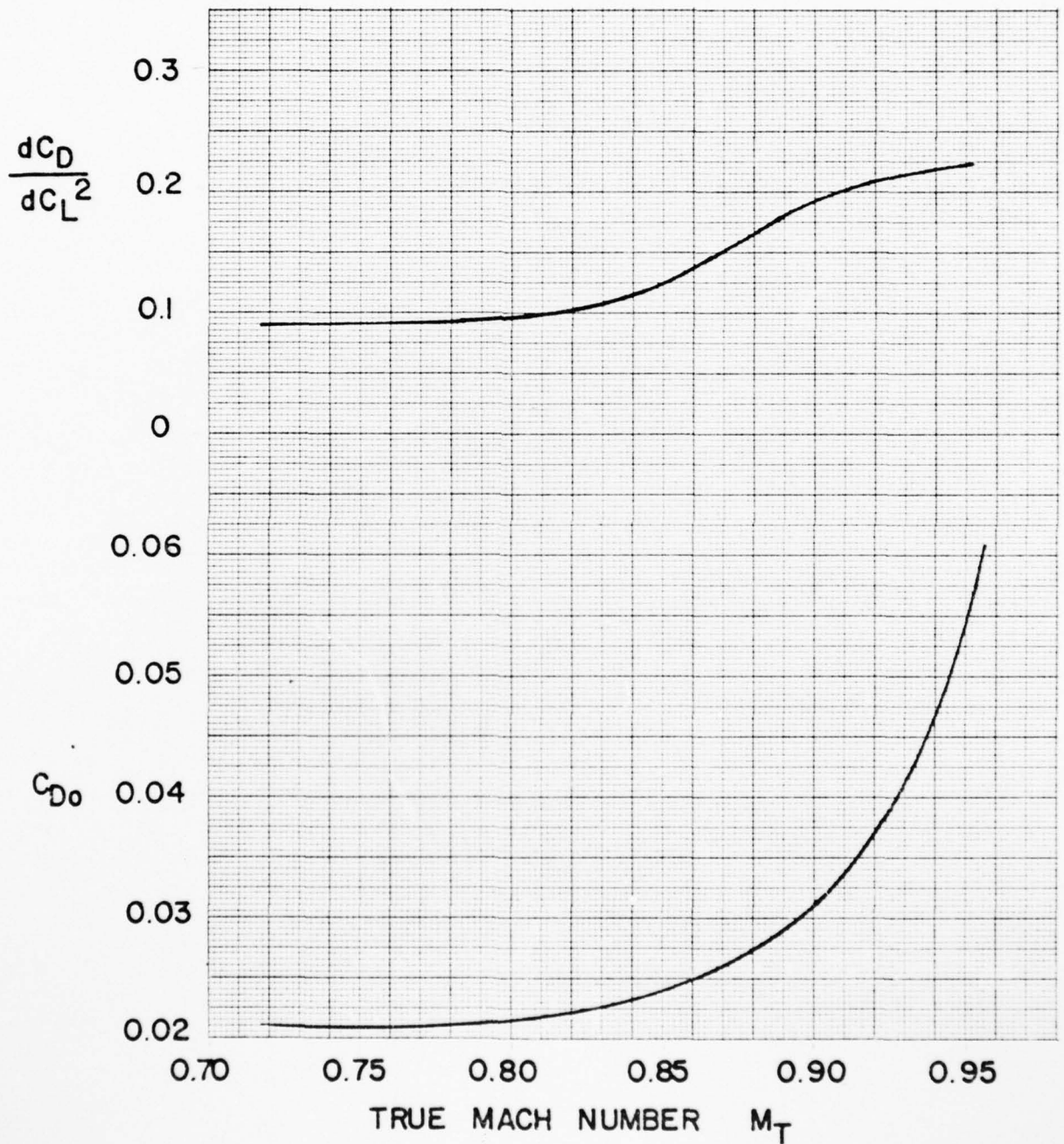
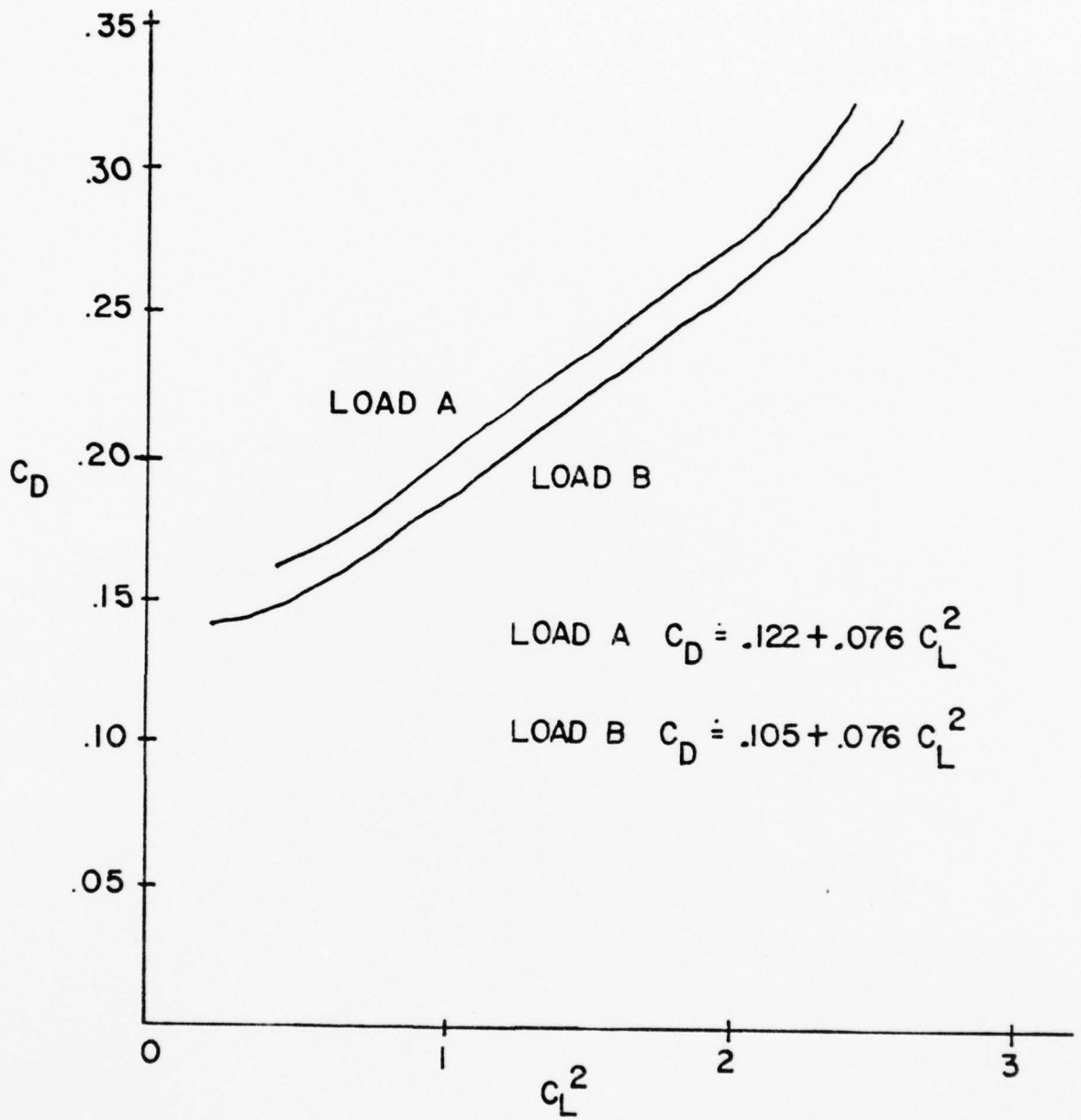

FIG. 2A-2



A-6A DRAG POLAR PARAMETERS
FIG. 2A-3



A-6A DRAG POLAR (TRIMMED)
Gear Down 30° Flaps

FIG. 2A-4

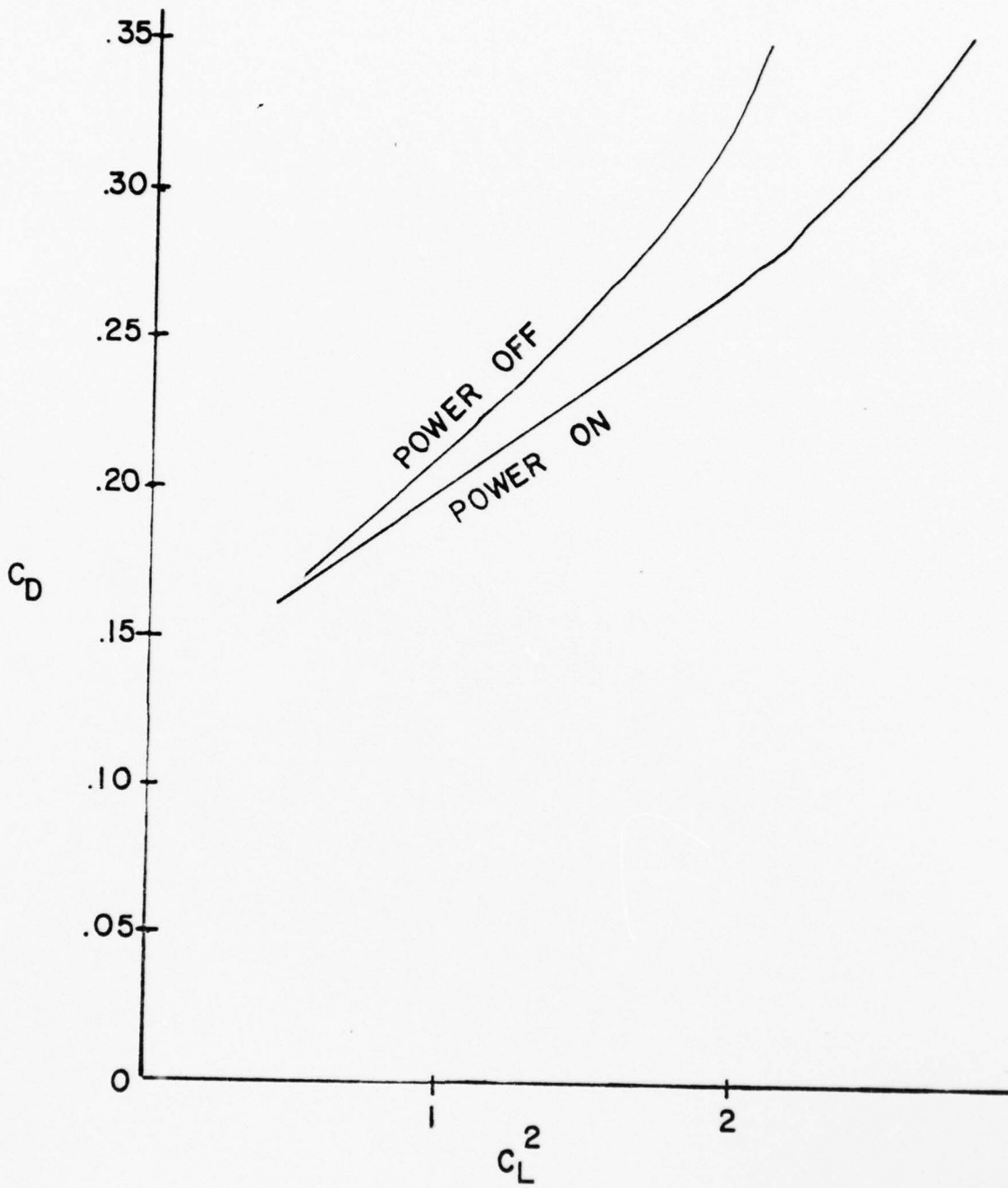

RA-5C TRIMMED DRAG POLAR
 Gear Down 50° Flaps 50° Droops
 CG = 29% MAC

FIG. 2A-5

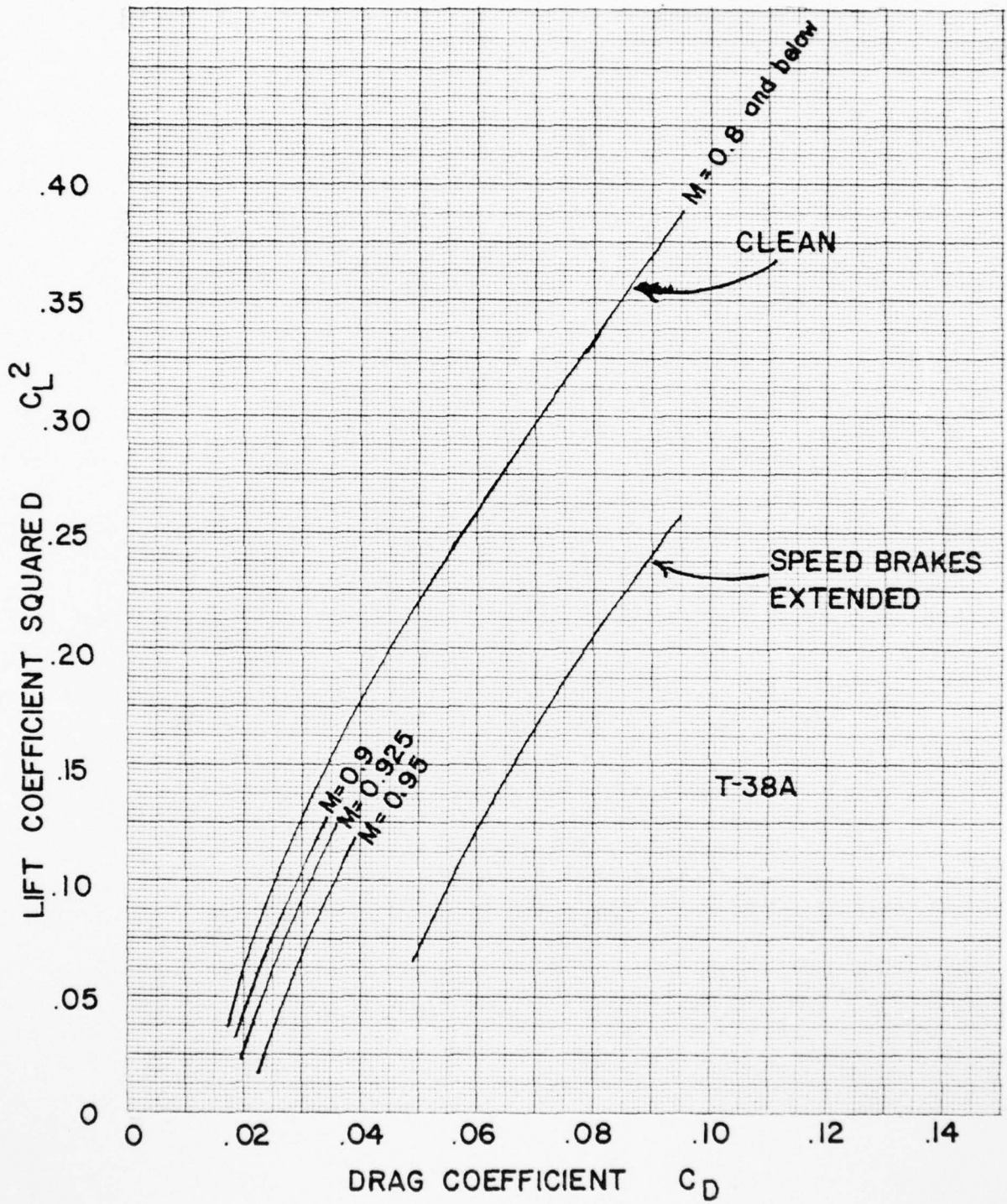

DRAG POLAR

FIG. 2A-6

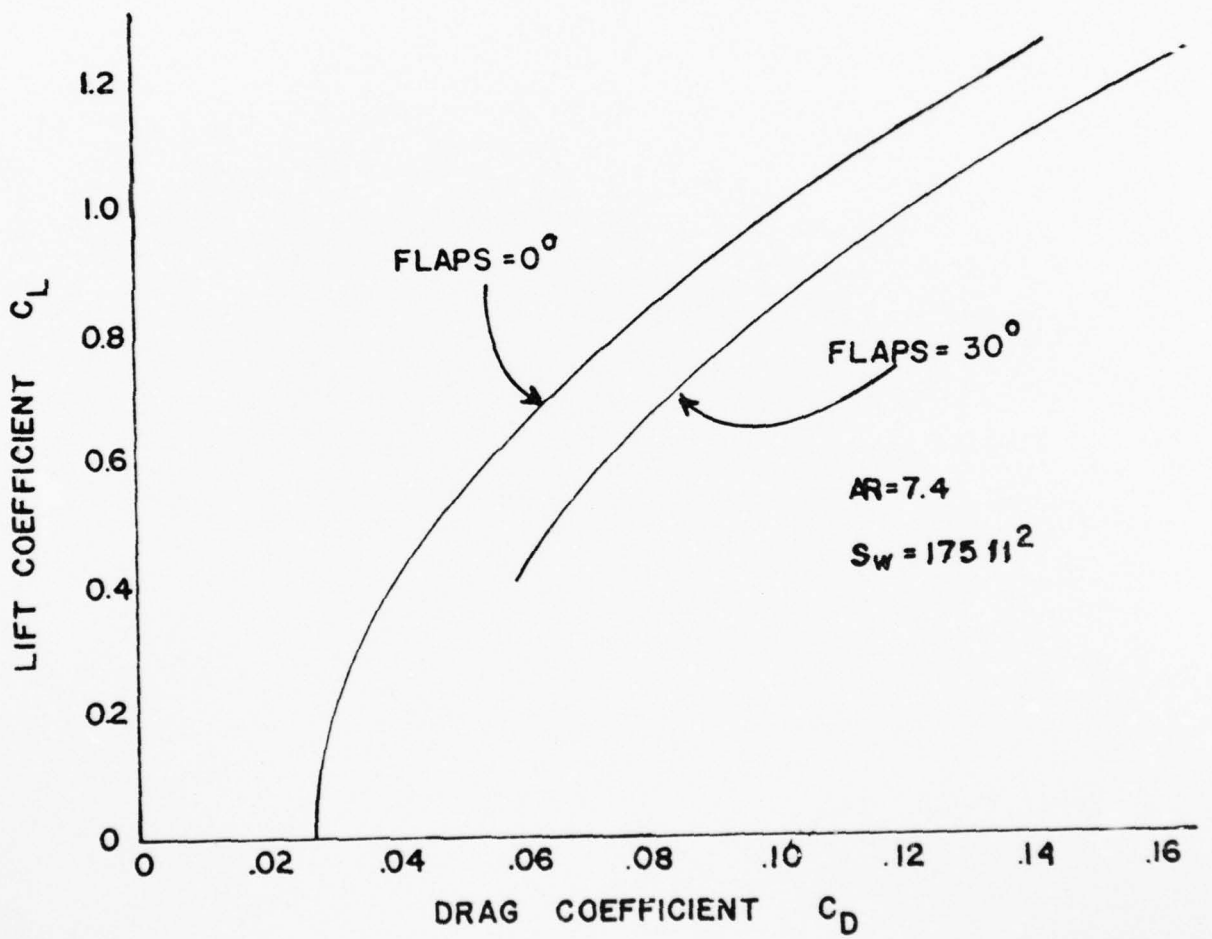

FIG. 2A-7

2A-2 DRAG EQUATION

In this section the equations relating the lift and drag characteristics of an airplane in level flight will be developed. These equations will then be analyzed to determine the speeds yielding minimum drag, the value of minimum drag, and the effects of weight, altitude and other variables on drag.

Lift and drag characteristics will only be considered in the speed region below the critical Mach Number (subsonic) where certain parameters are essentially independent of Mach Number. Lift and drag in the speed region above the critical Mach Number (transonic and supersonic) where these parameters may be Mach Number dependent will be covered in a subsequent course.

2A-3 Low Speed Drag Equation

A level flight drag equation may be developed where drag will be expressed as a function of airspeed. A parabolic drag polar will normally be assumed since this polar has both theoretical and experimental basis. Thus by definition

$$D = c_D q s \quad (8)$$

and assuming parabolic drag polar

$$C_D = C_{D_0} + \frac{C_L^2}{\pi e AR} \quad (9)$$

In order to develop an expression for the C_L in level flight, look at the forces acting on an airplane in level flight in Fig. 2A-8.

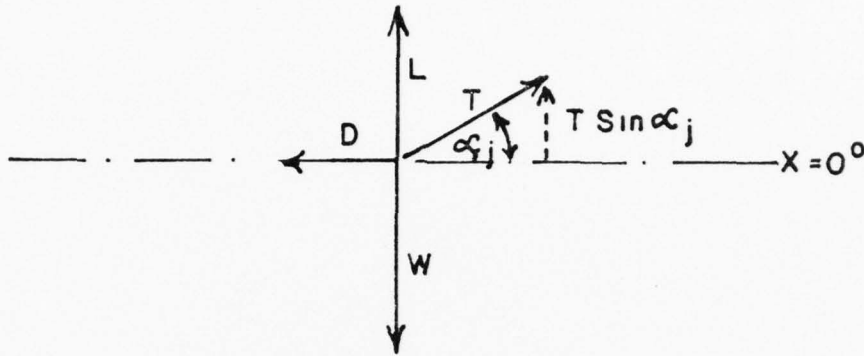

FIG. 2A-8

To maintain level flight

$$\Sigma F_z = 0$$

or

$$L - W + T \sin \alpha_j = 0 \quad (10)$$

solving for L we have

$$L = W - T \sin \alpha_j \quad (11)$$

Lift coefficient is defines as

$$C_L = \frac{L}{q_s}$$

substituting Equation 11 into the above gives

$$C_L = \frac{(W - T \sin \alpha_j)}{q_s} \quad (12)$$

Substituting the equation (12) into Equation 10, gives

$$D = C_{D_0} q s + \frac{(W - T \sin \alpha_j)^2}{\pi e AR q s} \quad (13)$$

To simplify the above equation, assume that weight (W) is much larger than the vertical thrust component ($T \sin \alpha_j$). This is probably a valid assumption for conventional airplanes in cruise flight where α_j will be small. However, at low speed (high α_j) and high thrust setting the assumption may introduce considerable error.

Assuming

$$W > T \sin \alpha_j$$

Equation 13 reduces to

$$D = C_{D_0} q s + \frac{W^2}{\pi e AR q s} \quad (14)$$

The dynamic pressure (q) can be expressed in any of the following ways

$$\begin{aligned} q &= 1/2 \rho_{ssL} V_e^2 \\ \text{or } q &= 1/2 \rho_a V_T^2 \\ \text{or } q &= 1/2 p_a \gamma M^2 \end{aligned}$$

By substituting any one of the above equations into Equation 14, the level flight drag equation may be rewritten as:

$$D = f(V_e) \quad D = C_{D_0} 1/2 \rho_{ssL} V_e^2 s + \frac{2 W^2}{\pi e AR s \rho_{ssL} V_e^2} \quad (15)$$

$$D = f(V_T) \quad D = C_{D_0} 1/2 \rho_a V_T^2 s + \frac{2 W^2}{\pi e AR s \rho_a V_T^2} \quad (16)$$

$$D = f(M) \quad D = \frac{C_{D_0} \gamma P_a M^2 s}{2} + \frac{2 W^2}{\pi e AR s \gamma P_a M^2} \quad (17)$$

2A-4 DRAG VARIABLES

In this section the above equations will be examined to see how the level flight drag equations are affected by the variables of the equations.

Equation 15 can be simplified considerably by letting

$$K_1 = \frac{C_{D_0}}{2} \rho_{ssL} S$$

$$K_2 = \frac{2W^2}{\pi e AR s} \rho_{ssL}$$

(NOTE that these are not the same constants, K_1 and K_2 , as used in Section 2A-1)

Thus Equation 15 becomes

$$D = \underbrace{K_1 V_e^2}_{\text{parasite drag } (D_p)} + \underbrace{\frac{K_2}{V_e^2}}_{\text{induced drag } (D_i)} \quad (18)$$

K_1 and K_2 will, in fact, be constant under the following conditions:

- a. Airplane configuration fixed and "working" at low Mach Numbers.

Thus

$$C_{D_0} = k_1$$

$$1/\pi e AR = k_2$$

$$S = k_3$$

- b. At a given gross weight (W)

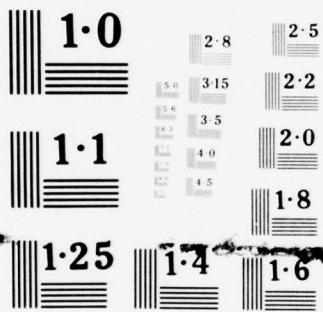

NATIONAL BUREAU OF STANDARDS
MICROCOPY RESOLUTION TEST CHART

A sketch of Equation 18 is shown below in Fig. 2A-9

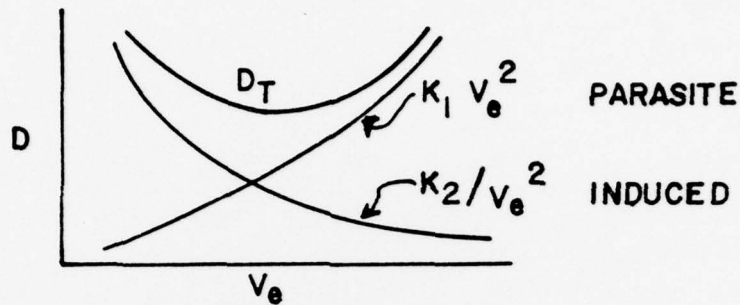

FIG. 2A-9

The general features of the curve are:

- a. Positive sloped segment is often called the "front side"
- b. Negative sloped segment is called the "back side"
- c. The portion of the curve surrounding the minimum drag point is called the "bucket" of the curve.
- d. The minimum speed point is the level flight stall speed.

2A-5 Level Flight Drag Equation - General Form

A more general form of the level flight drag equation (a form that is not based on the parabolic polar) is developed below. Since drag (D) can be expressed as

$$D = \left[\frac{D}{L} \right] \cdot L$$

Dividing the numerator and denominator of the bracketed term by qs gives

$$D = \frac{C_D}{C_L} \cdot L \quad (19)$$

Assuming level flight and no appreciable "thrust" lift ($\alpha_j = 0$) we can assume

$$L = W$$

and, substituting the above into Equation 19 gives the general form of the level flight drag equation.

$$D = \frac{C_D}{C_L} \cdot L$$

or

$$D = \frac{W}{\left[\frac{C_L}{C_D}\right]} \quad (20)$$

The drag for level flight is therefore dependent on:

- a. The gross weight (W). (Directly)
- b. The ratio of C_L to C_D . (Inversely)

The evaluation of level flight drag for the arbitrary drag polar is illustrated below.

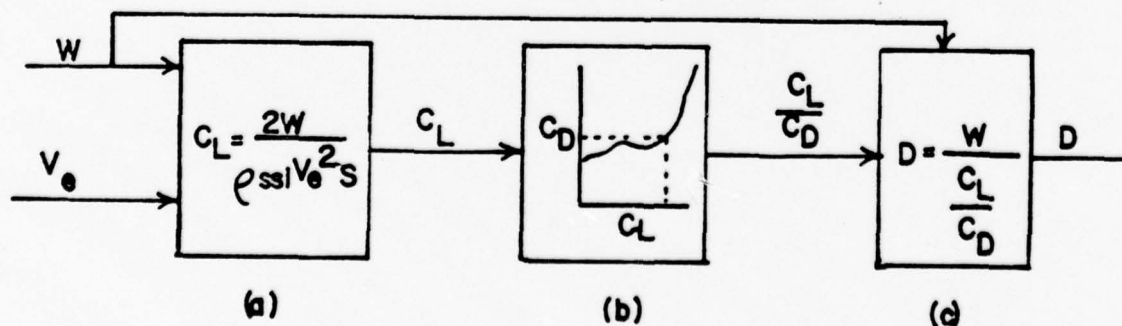

FIG. 2A-10

Thus for a given weight and airspeed, the level flight drag can be obtained by

- a. First determining the C_L required for level flight at the given weight and airspeed.
- b. Then referring to the drag polar at the above C_L and determining the corresponding C_L/C_D .
- c. Computing the level flight drag D .

2A-6 Conditions for Minimum Drag

- a. Parabolic Polar

The conditions for minimum drag can now be determined. For an airplane with a parabolic drag polar,

$$D = K_1 V_e^2 + K_2 V_e^{-2} \quad (18)$$

The minimum drag point is found by setting the derivative of the drag with respect to V_e equal to zero.

$$\frac{dD}{dV_e} = 0$$

Thus

$$\frac{dD}{dV_e} = 0 = 2 K_1 V_e - 2 K_2 V_e^{-3}$$

Multiplying the above by $V_e/2$ and rearranging gives

$$K_1 V_e^2 = K_2 V_e^{-2}$$

or

$$D_p = D_i \quad (21)$$

which, when divided by qs , gives

$$C_{D_0} = C_{D_i} \quad (22)$$

Thus it is shown that minimum drag occurs at that point on the $D = f(V_e)$ curve where $D_p = D_i$. On the drag polar $[C_D = f(C_L)]$ the same minimum drag point is that point where $C_{D_1} = C_{D_0}$. See the sketch below

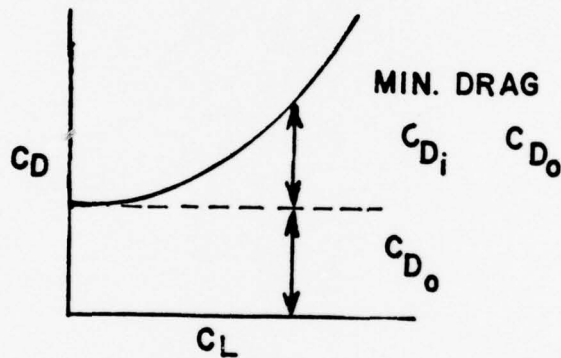

FIG. 2A-11

b. General Polar

Assuming a general polar, equation 20 can be used to illustrate the conditions for minimum drag.

$$D = \frac{W}{C_L/C_D}$$

For minimum drag at any given weight

$$D_{\min} = \frac{W}{\left. \frac{C_L}{C_D} \right|_{\max}} \quad (23)$$

To minimize drag the C_L/C_D ratio must be maximized. A maximum C_L/C_D ratio (or minimum C_D/C_L ratio) can be found graphically by placing a straight line through the origin and tangent to the $C_D = f(C_L)$ curve.

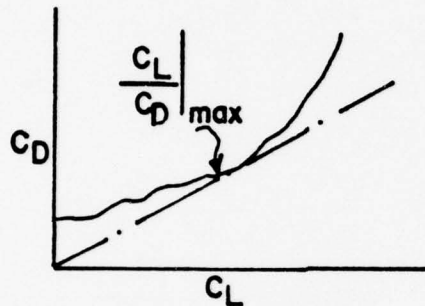

FIG. 2 A-12

NOTE: The angle θ is $\tan^{-1} C_D/C_L$ and the minimum angle is the minimum C_D/C_L ratio. Therefore, a line drawn from the origin tangent to the curve locates C_D/C_L min or C_L/C_D max.

2A-7 More on Sketching the Level Flight Drag Equation [$D = f(V_e)$]

Look now at the effects of the variables (C_{D_0} , W) on the level flight drag curves $D = f(V_e)$

a. Weight Effect

From the drag equation (Equation 15), it is seen that weight (W) appears only in the induced drag term. This effect is to change the K_2 term in equation 18, i.e.

$$D = K_1 V_e^2 + K_2 V_e^{-2}$$

where

$$K_2 = \frac{2W^2}{\pi eAR S \rho_{ssL}} \quad (24)$$

Equation (24) shows that K_2 varies as the square of the weight. For example, increasing the weight by a factor of two would increase K_2 by a factor of four. The total drag for an increased weight is obtained by adding the new induced drag term ($K_2' V_e^{-2}$) to the parasite drag. It is also apparent that the total drag change (ΔD) is as shown below

$$\Delta D = \Delta D_i$$

or

$$\Delta D = \Delta K_2 V_e^{-2}$$

or

$$\Delta D = \left[\frac{2(W_2^2 - W_1^2)}{\pi e A R S \rho_{ssl}} \right] V_e^{-2} \quad \text{where } W_1 = \text{original weight}$$

and $W_2 = \text{new weight}$

Figure 2A-13 illustrates the effects of a weight change on the $D = f(V_e)$ curve. The effects of a weight change is summarized below.

- Large drag changes occur at low speed and relative small changes occur at high speeds.
- The minimum drag speed increases as weight increases. The locus of minimum drag point is

$$D_{\min} = \left[\frac{C_{D_M}}{2} \rho_{ssl} S \right] V_e^2$$

where C_{D_M} is the drag coefficient corresponding to the $C_L/C_{D_{\max}}$ point.

- The slope of the drag curve at any given V_e becomes less positive as weight increases.

- ° The $C_{L_{\max}}$ speed increases as weight increases. The locus of $C_{L_{\max}}$ points on the $D = f(V_e)$ curve is

$$D_{CL} = \frac{C_{D_S}}{2} \rho_{ssl} S V_e^2$$

where C_{D_S} is the drag coefficient corresponding to the $C_{L_{\max}}$

b. C_{D_o} Effect

The effect of a variation in C_{D_o} on the drag equation is to change the K_1 term in the drag equation

$$D = K_1 V_e^2 + K_2 V_e^{-2}$$

where

$$K_1 = \frac{C_{D_o} \rho_{ssl} S}{2}$$

We see that K_1 will change proportionally to the C_{D_o} change. The change in total drag will be the same as the change in parasite drag (the induced drag doesn't change)

$$\Delta D = \Delta D_p = \left[\frac{C_{D_o} \rho_{ssl} S}{2} \right] V_e^2$$

the effect of a change in C_{D_o} is illustrated in Figure 2A-14.

Note the following for changes in C_{D_o} .

- ° The large drag changes occur at the higher speed and relative low drag changes occur at the low speeds.

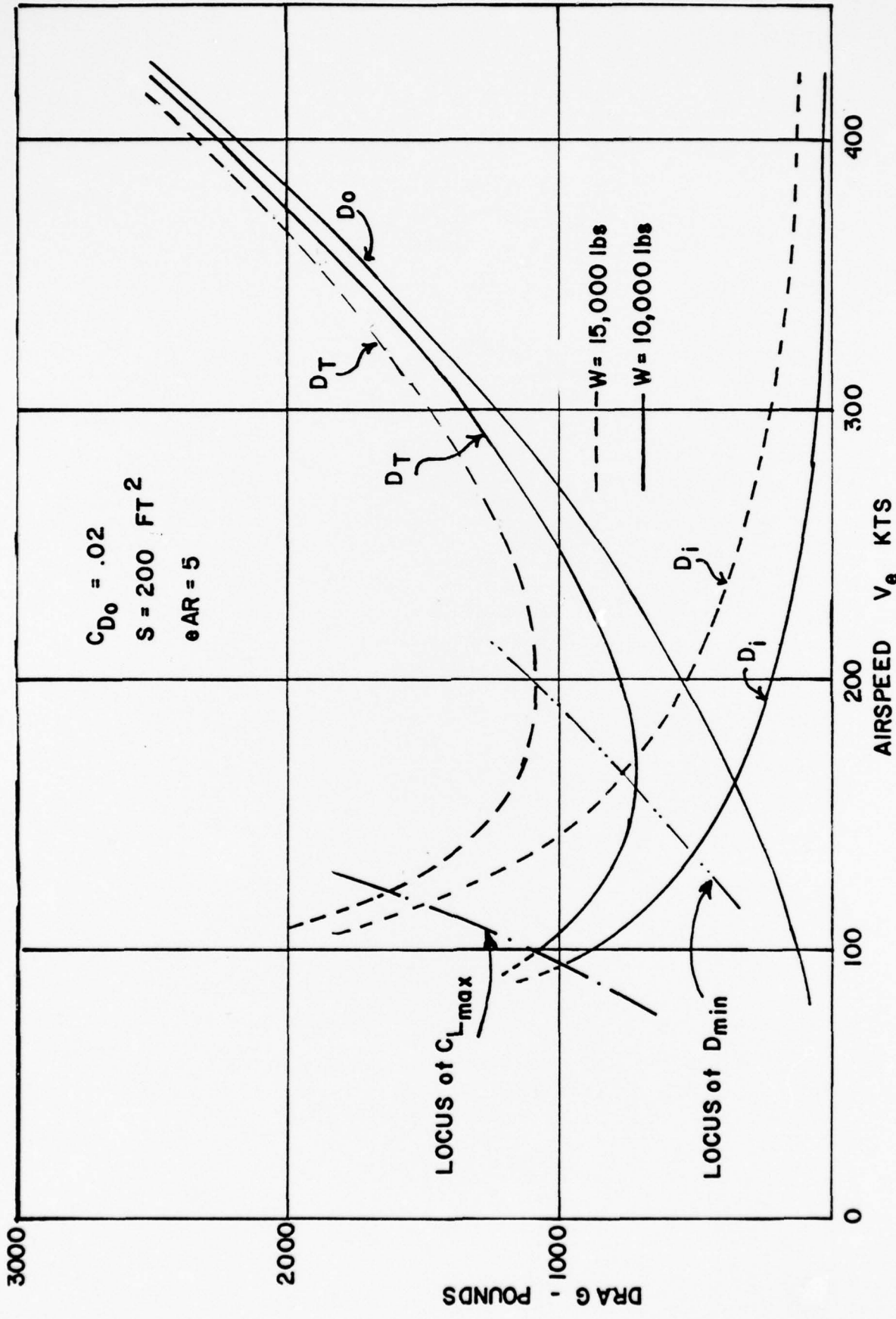

FIG. 2A-13

- The minimum drag speed decreases as C_{D_0} increases. The locus of the minimum drag point is

$$D_{\min} = \frac{4 W^2}{\pi e A R S \rho_{ssl}} V_e^{-2} \quad (\text{See Problem 2A-II})$$

- The slope of the $D = f(V_e)$ curve is more positive at all speeds.

c. Altitude Effect

The low speed drag equation $[D = f(V_e)]$ does not contain any altitude dependent variables and therefore changes in altitude will not effect this drag curve. (There will however be a change in the $D = f(V_e)$ curve if the Mach effects are included).

2A-8 Sketching the Level Flight Drag Equation $[D = f(V_t)]$

The effects of W , C_{D_0} and h on the $D = f(V_t)$ curve.

a. Weight Effects

The effects of weight and C_{D_0} on the $D = f(V_t)$ curve are very similar to the effects of same variables (W and C_{D_0}) on the $D = f(V_e)$ curve.

b. C_{D_0}

A detailed analysis of the W and C_{D_0} effects will not be presented in this section since it would be very similar to the discussion in the previous section.

c. Altitude Effects

Two methods are available to determine the effects of altitude on the $D = f(V_t)$ curve.

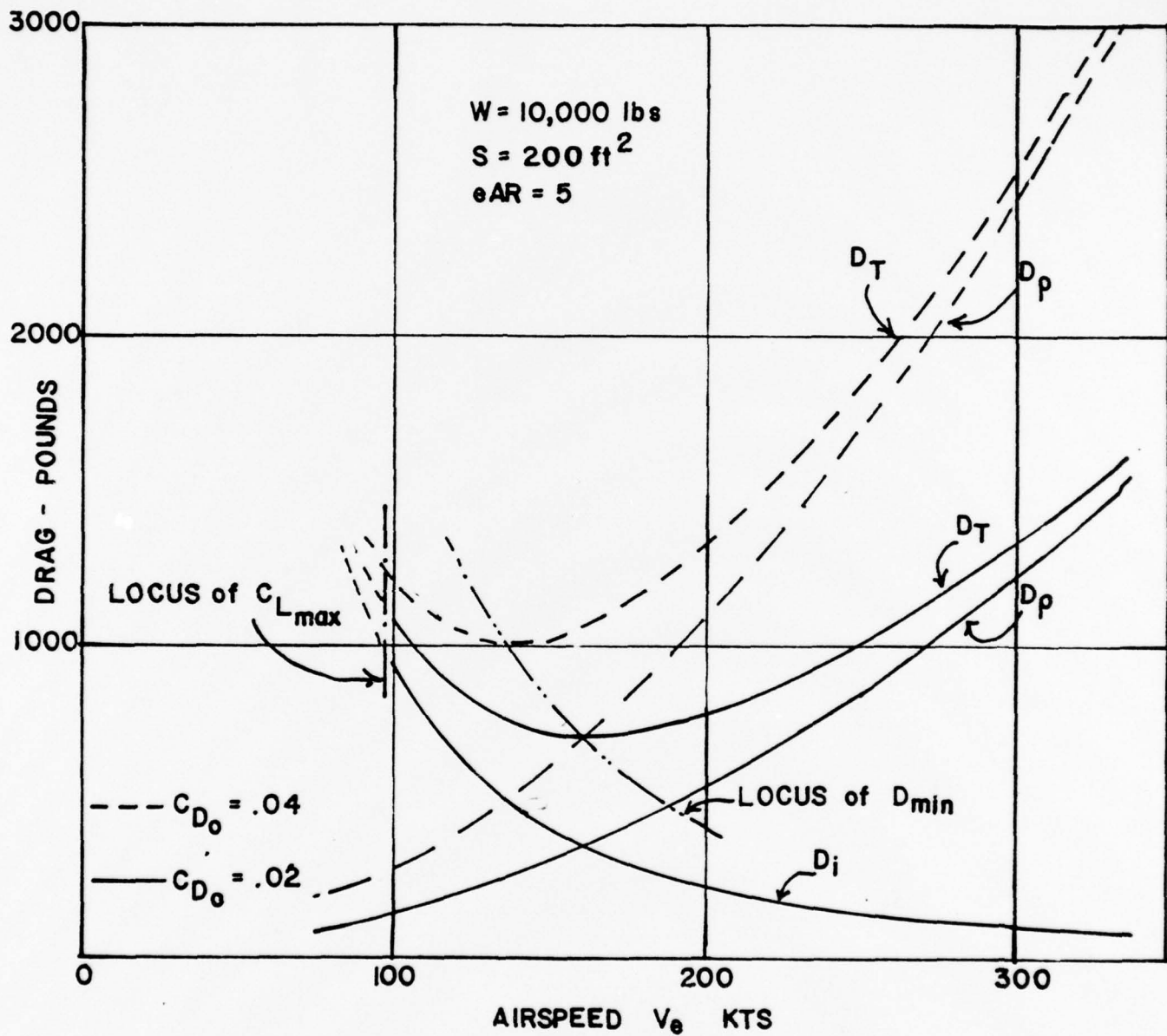

FIG. 2A-14

Method I - It has been shown that the $D = f(V_e)$ does not change with altitude. Inasmuch as

$$V_e = V_t \sqrt{\sigma}$$

the $D = f(V_t \sqrt{\sigma})$ curve (below) will be independent of altitude (again "low speed")

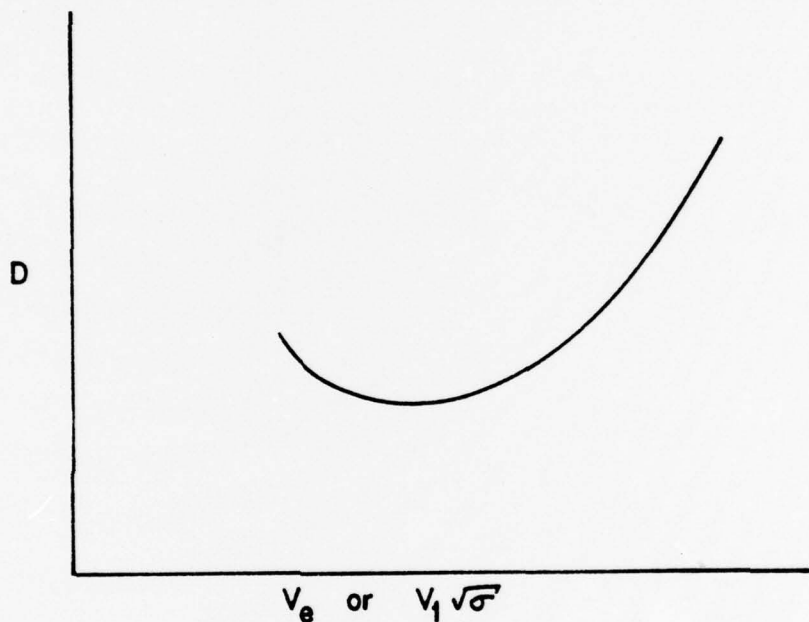

FIG. 2A-15

Thus any point (D and V_e) on the above drag curve will correspond to the same drag level and a higher V_t ($V_t = V_e / \sqrt{\sigma}$) at higher density altitude. A plot of a drag curve [$D = f(V_t)$] standard sea level $\sigma = 1$ and then at a higher h_p (lower σ) as shown below.

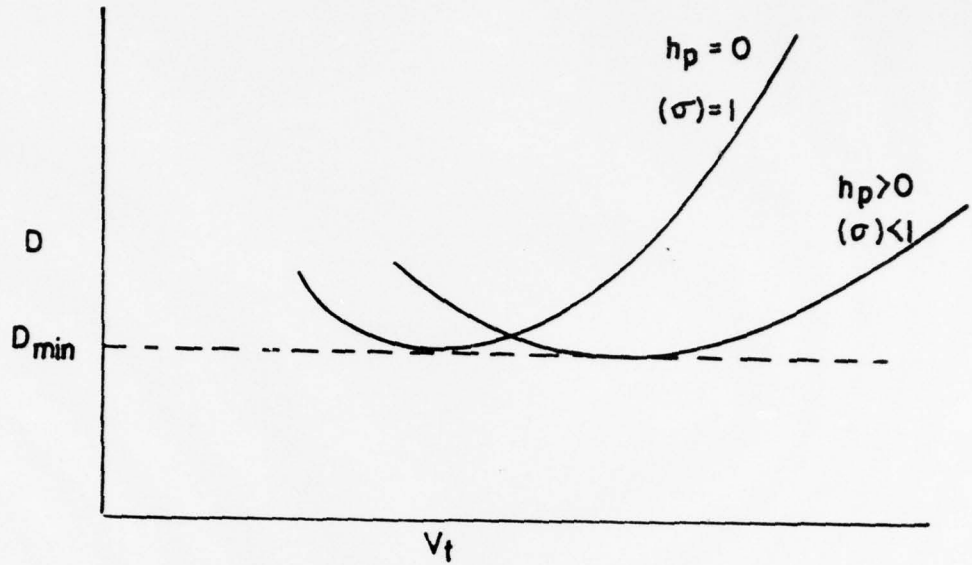

FIG. 2A-16

The altitude effects are summarized below

- The curve "shifts" to a higher speed
- The minimum drag point moves to a higher V_t (same $V_e/\sqrt{\sigma}$)
- The value of the minimum drag is unchanged
- With the assumption of no $C_{L_{max}}$ change [$C_{L_{max}} = f(R_n)$] and no thrust lift, the stall point shifts to a higher V_t at the same drag (D).

Method II - Another way to analyze the effects of density changes on the

$D = f(V_t)$ curve is to examine the $D = f(V_t)$ equation

(Equation 16). The equation can be written as

$$D = K_1 V_t^2 + K_2 V_t^{-2}$$

where

$$K_1 = \frac{C_{D_0} \rho_a S}{2}$$

and

$$K_2 = \frac{2W^2}{\pi eARS \rho_a S}$$

(Note again that these are different values of K_1 and K_2)

Inasmuch as density terms (ρ_a) appears in both the parasite and induced drag terms, an increase in density altitude will

a. decrease K_1

and

b. increase K_2

A plot of the $D = f(V_t)$ equation as ρ_a varies is shown in Figure 2A-17.

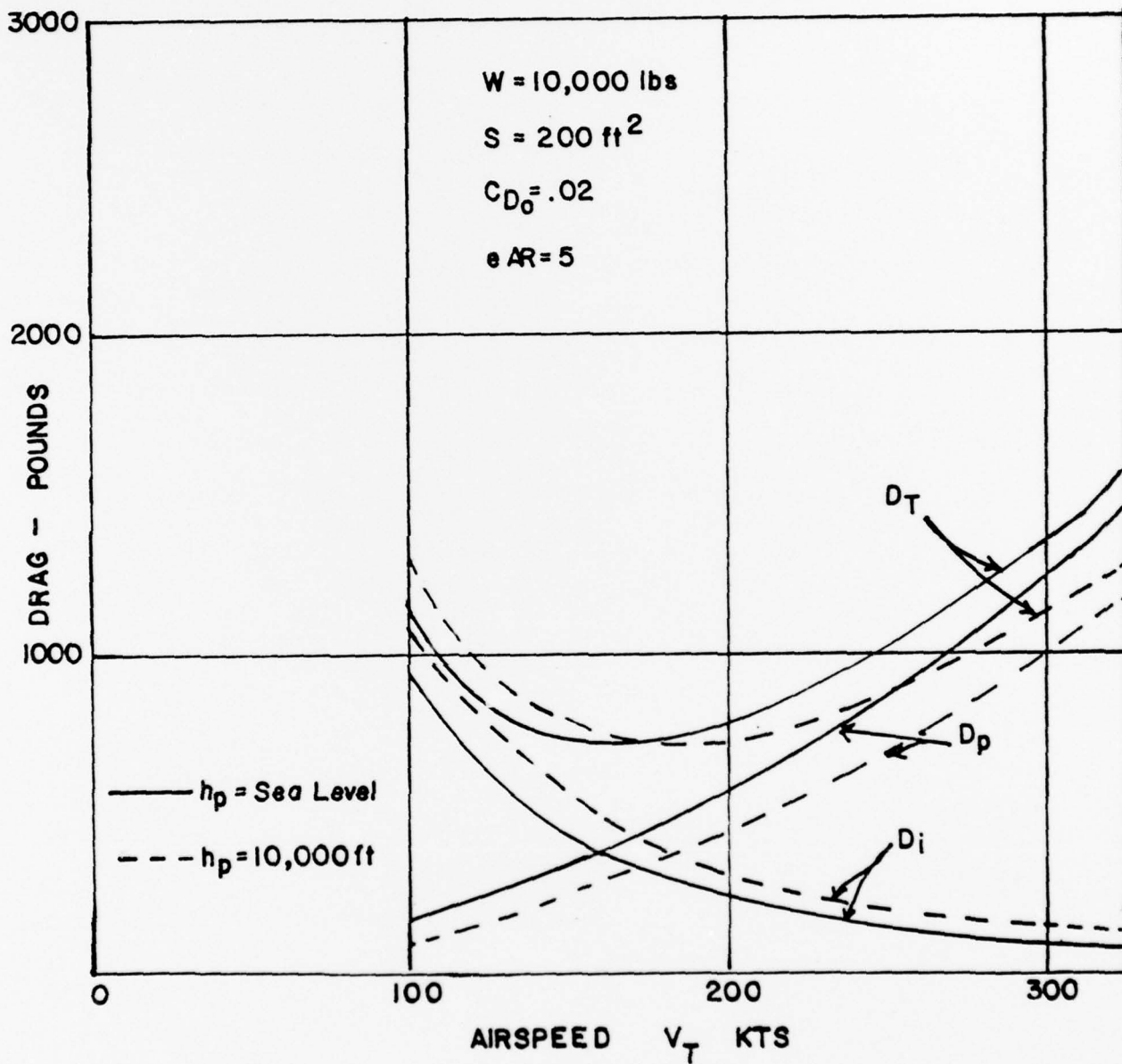

FIG. 2A-17

PROBLEMS (2A-II)

Given an airplane with the drag polar

$$C_D = .05 + .1 C_L^2 \quad C_{L_{\max}} = 1.5$$

and

$$S = 200 \text{ ft}^2$$

$$\rho_a = .002 \text{ slug/ft}^3$$

$$W = 10,000 \text{ lbs}$$

- a. Graph $D_p = f(V_e)$ for level flight
- b. Graph $D_i = f(V_e)$ for level flight
- c. Graph $D = f(V_e)$ for level flight

Solve for the following (by equations) and compare the results with the graph made above.

- d. What is the minimum drag lift coefficient (use $C_{D_i} = C_{D_o}$)
- e. What is the minimum drag speed (V_e)
- f. What is the stall speed
- g. What are the levels of drag associated with parts e and f.

ANSWERS

- d. .707
- e. $V_e = 244 \text{ fps}$
- f. $V_e = 167 \text{ fps}$
- g. e 1414 lbs
f 1833 lbs

UNIT 2 B

POWER REQUIRED

2B-1 DRAG VERSUS VELOCITY

An aircraft with a specified wing loading (Weight divided by wing area, W/S), operating at a specified altitude (ρ) in unaccelerated flight ($W = L$), must have a Coefficient of Lift

$$C_L = \frac{W/S}{\frac{1}{2}\rho V^2} = K_1 V^{-2} \quad (1)$$

where $K_1 = c$

and each value of Lift Coefficient may be represented by a value of Velocity. And since the Drag Coefficient

$$C_D = \frac{D}{\frac{1}{2}\rho V^2 S} \quad (2)$$

for each value of velocity computed from equation (1), the Drag of the aircraft is related to a specific value of Drag Coefficient. Thus it is that the Polar (C_L vs C_D), by a change of scale, may become a plot of Drag versus Velocity, valid for one wing loading at one altitude.

The two types of low Mach Drag, Parasite and Induced, may also be plotted as a function of velocity. Parasite Drag is a function of the square of the Velocity,

$$D_p = C_{D_p} \frac{1}{2} S V^2 \rho \quad (3)$$

while Induced Drag is a function of the inverse square of the Velocity,

$$D_i = C_{D_i} \frac{1}{2} \rho S V^2 \quad (4)$$

$$= \left(\frac{C_L^2}{AR\pi e} \right) \frac{1}{2} \rho S V^2$$

$$= \left(\frac{2 W/S}{\rho V^2} \right)^2 \left(\frac{1}{AR\pi e} \right) \frac{1}{2} \rho S V^2$$

$$D_i = \left(\frac{2(W/S)^2}{\rho AR\pi e} \right) \frac{1}{V^2} \quad (5)$$

A summation of the Induced Drag and the Parasite Drag gives the total, low Mach Drag for the aircraft as shown in Figure 2B-1.

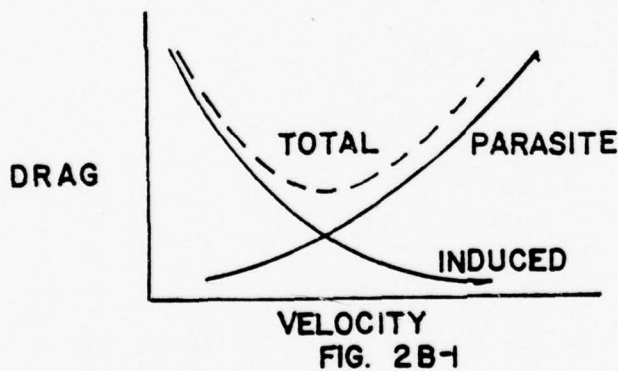

Figure 2B-1 Drag/Velocity Relationship for One Value of W/S at one ρ .

From equations (3) and (5) it may be seen that Total Drag is the sum of some function of Velocity squared and some other function of the inverse of the Velocity squared,

$$D_T = f_1(V)^2 + f_2 \left(\frac{1}{V} \right)^2 \quad (6)$$

To find the minimum value of Drag, equation (6) is differentiated with respect to Velocity and set equal to zero

$$\frac{dD_T}{dV} = 2 f_1(V) - 2 f_2 \left(\frac{1}{V}\right)^3 = 0 \quad (7)$$

$$\text{and } V^4 = f_2/f_1 \quad (8)$$

$$\text{or } f_1 V^2 = f_2/V^2 \quad (9)$$

Equation (9) shows that the minimum Total Drag occurs when the Induced Drag (f_2/V^2) is equal to the Parasite Drag ($f_1 V^2$). The Velocity for minimum Drag is of importance for several reasons, not the least of which is that this is the Velocity for Best Glide.

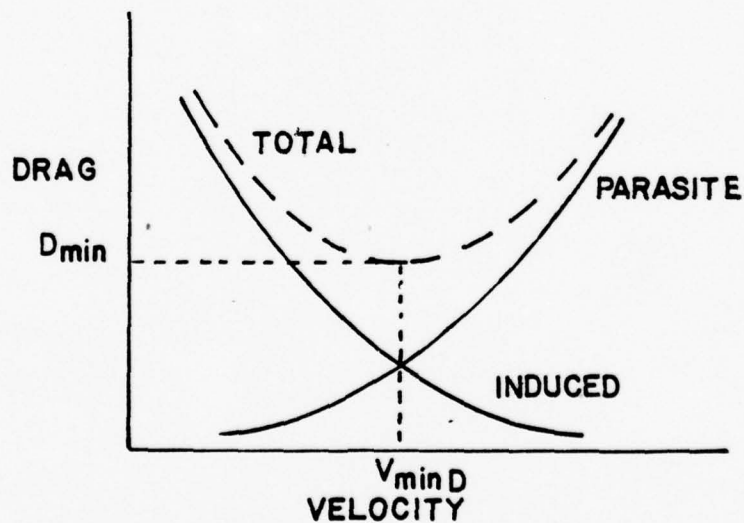

FIG. 2B-2

2B-2 THRUST REQUIRED

From the original equations of equilibrium for unaccelerated level flight, Thrust must equal Drag. Therefore, Figures 2B-1 and 2B-2 can be converted to Thrust versus Velocity curves with no change in scale. In a manner similar to the division of Drag into two basic types, Thrust may also be listed as the Thrust required to overcome Parasite Drag (Parasite Thrust) and the Thrust required to overcome Induced Drag (Induced Thrust). It should be noted that these labels of Thrust are artificialities, by itself, the term "Induced" Thrust has no meaning. However, if one were to consider the total Thrust required for flight as being composed of two elements, each of which overcomes a certain type of Drag, variation analysis is simplified. For example, if Total Drag, and therefore Thrust, were computed for one aircraft in one flight configuration, the Thrust Required due to a change in configuration such as the opening of a Leading Edge Slat could be computed as an addition to the Induced Thrust required to balance the Induced Drag change.

2B-3 POWER REQUIRED

Power had dimensions of ML^2T^{-3} , foot-pounds per second, where 550 foot-pounds per second are equal to one Horsepower. Since Force such as Thrust, has the dimensions of MLT^{-2} , the product of Thrust and Velocity, (LT^{-1}) , is power. Therefore, if Velocity is expressed in feet per second, and Thrust is expressed in pounds weight, power is, in Horsepower units,

$$THP = \frac{T V}{550} \quad (10)$$

where

T = Thrust force along the relative wind axis (lbs)

V - true airspeed (fps)

550 - conversion factor $(550 \frac{\text{ft-lb}}{\text{sec}} = 1 \text{ horsepower})$

The thrust horsepower required to keep the airplane in level flight would be dependent on the Thrust (T) [or the Drag (D)] and the true airspeed. Since we have already developed a drag equation for level flight (Equations 3 and 5), we will substitute these equations into Equation 10 and the result is:

$$\text{THP} = \frac{C_{D0} \rho_a V_T^3 S}{1100} + \frac{W^2}{275\pi e AR S \rho_a V_T} \quad (11)$$

The assumptions (limitations) of the above equation are the same as for the drag equation. That is

- a. $C_D = f(C_L)$ thus $C_D \neq f(M, R_n)$
- b. Parabolic polar $C_D = C_{D0} + C_L^2 / \pi e AR$
- c. Level flight with no "thrust" lift ($L = W$)

The sketching of the above equation is simplified if we

- a. Fix the airplane external configuration and restrict the equation to "low" Mach. Thus S , C_{D0} and $1/\pi e AR$ will all be constant
- b. Fix the gross weight (W)
- c. Fix the (ρ_a) or density altitude (h_ρ)

Under the above conditions the equation can be written as

$$\text{THP} = K_1 V_T^3 + \frac{K_2}{V_T} \quad (12)$$

Subscripts
p - parasite
i - induced

where

$$K_1 = \frac{C_{D_0} \rho_a S}{1100}$$

and

$$K_2 = \frac{W^2}{2.5\pi e AR S \rho_a}$$

Sketching the above we have

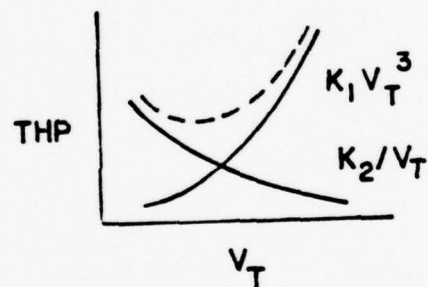

FIG. 2B-3

2B-4 Level Flight Power Equation - General Form

A general form of the power required equation (one that is not based on an analytic form of the drag polar) is developed below. In level flight the thrust horsepower required is

$$\text{THP} = \frac{D V_T}{550} \quad (13)$$

In level flight we can express drag as follows

$$D = \frac{C_D}{C_L} \cdot W \quad (14)$$

Substituting the above expression for drag into Equation 13 gives

$$THP = \frac{C_D}{C_L} \cdot \frac{W V_T}{550} \quad (15)$$

In level flight (assuming $\alpha_j = 0$)

$$\Sigma F_z = L - W = 0$$

thus

$$L = W = C_L \frac{1}{2} \rho_a V_T^2 S \quad (16)$$

Solving for V_T and substituting into Equation 15 gives

$$THP = \left(\frac{2}{S}\right)^{1/2} \frac{W^{3/2}}{\rho_a^{1/2}} \frac{C_D}{C_L^{3/2}} \frac{1}{550} \quad (17)$$

If we substitute the following into the above

$$\rho_a = \rho_{ss1} \cdot \sigma_{ss1}$$

We get the final form of the "general" level flight power required equation

$$THP = \frac{2}{S} \rho_{ss1}^{1/2} \frac{W^{3/2}}{\sqrt{\sigma}} \frac{C_D}{C_L^{3/2}} \frac{1}{550} \quad (18)$$

2B-5 Conditions for Minimum Thrust Horsepower Required

(a) Parabolic Polar

The conditions for minimum power required in level flight will first be determined for an airplane with a parabolic polar. Thus

$$\text{THP} = K_1 V_T^3 + K_2 V_T^{-1} \quad (19)$$

taking the derivative and setting it to zero gives

$$3K_1 V_T^2 - K_2 V_T^{-2} = 0 \quad (20)$$

Multiplying by V_T and rearranging gives

$$3K_1 V_T^3 = K_2 V_T^{-2} \quad (21)$$

Thus at minimum power required

$$3 \text{THP}_p = \text{THP}_i \quad (22)$$

Or, multiplying by $550/V_T$

$$3 D_p = D_i \quad (23)$$

And, finally, dividing both sides by qs gives

$$3 C_{D_0} = C_{D_i} \quad (24)$$

Equations 22, 23, and 24 are alternate ways of identifying the minimum power condition. Equation 24 relates directly to the parabolic drag polar and identifies a unique point on the drag polar that will produce the minimum power required in level flight.

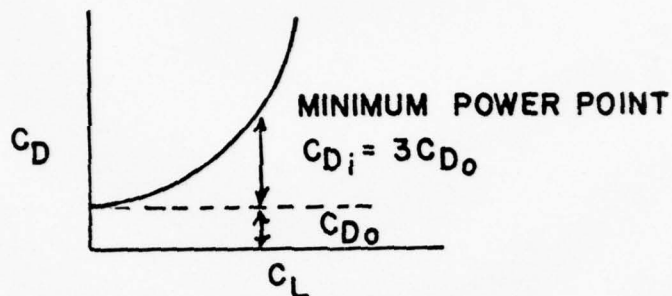

FIG. 2B-4

Thus we see that there is a "best" C_L to fly at to minimize the power required just like there was another "best" C_L for minimum drag. Additionally, we see that the minimum power point occurs at higher C_L (lower speed) than the minimum drag point.

(b) General Polar

The more general conditions for minimum power required are discussed below. By using the general form of the power required equation (Equation 18) we have for a given weight and density altitude

$$THP = K \frac{C_D}{C_L^{3/2}} \quad (25)$$

Therefore, to minimize power required, we must minimize the ratio of C_D to $C_L^{3/2}$

$$THP_{\min} = K \left. \frac{C_D}{C_L^{3/2}} \right|_{\min} \quad (26)$$

or

$$\text{THP}_{\min} \text{ Occurs at } \left. \frac{C_L^{3/2}}{C_D} \right|_{\max} \quad (27)$$

Hence we see that if we locate that point on the polar that gives the maximum ratio of $C_L^{3/2}$ over C_D then the power required will be minimum. The above is illustrated in the sketch below

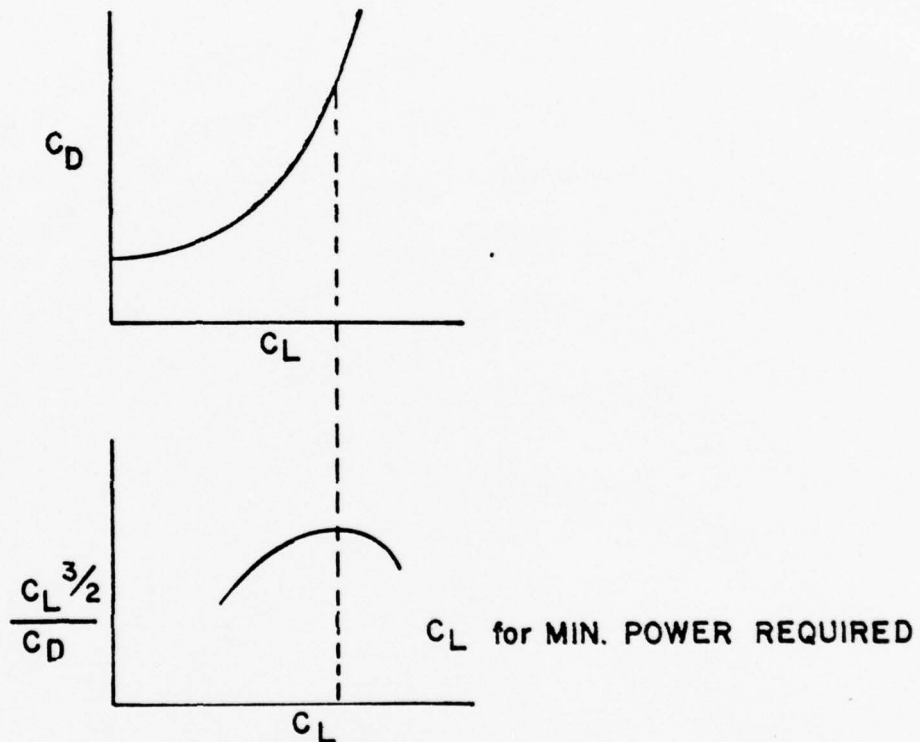

FIG. 2B-5

2B-6 Sketching the Level Flight Thrust Horsepower Equation [$\text{THP} = f(V_t)$].

We will now look at the effects of the variables (C_{D_0}, W) on the level flight THP curve.

a. Weight Effect

Looking at the power equation (Equation 11) we see that weight (W) appears only in the induced power term. This effect is to change the K_2 term in the equation.

$$\text{THP} = K_1 V_t^3 + K_2 V_t^{-1} \quad (28)$$

where

$$K_2 = \frac{W^2}{275 \pi eAR S \rho_a}$$

We see that K_2 varies as the square of the weight. For example, increasing the weight by a factor of two would increase K_2 by a factor of four. The total power for an increased weight is obtained by adding the new induced power term $K_2 V_t^{-1}$ to the parasite power. It is also apparent that the total power change is as shown below.

$$\Delta \text{THP} = \frac{(W_2^2 - W_1^2)}{275 \pi eAR S \rho_a} V_t^{-1} \quad \begin{array}{l} \text{where } W_1 = \text{original weight} \\ \text{and } W_2 = \text{new weight} \end{array} \quad (29)$$

Figure 2B-6 illustrates the effects of a weight change on the $\text{THP} = f(V_t)$ curve. The effects of a weight change is summarized below.

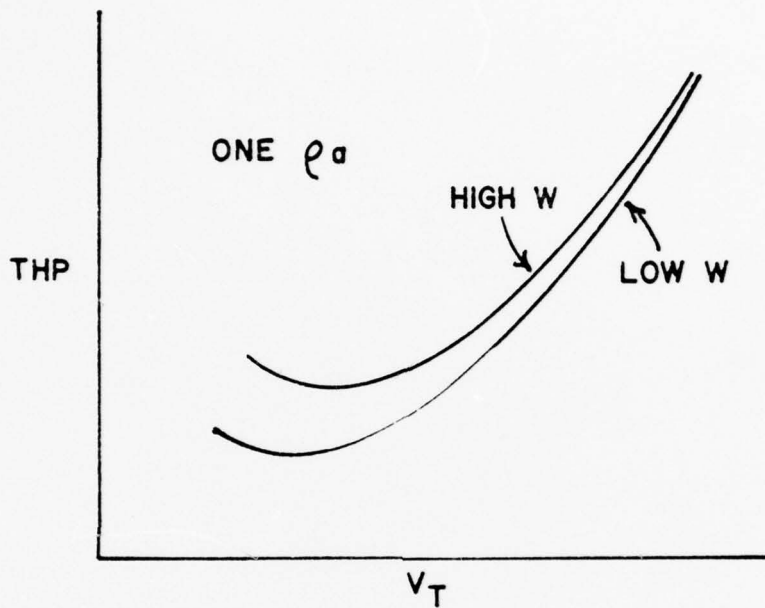

FIG. 2B-6

- Large power changes occur at low speed and relative small changes occur at high speeds.
- The minimum power speed increases as weight increases. The locus of minimum power point is

$$THP_{\min} = \left[\frac{C_{D_M}}{1100} \rho_a S \right] v_t^3 \quad (30)$$

where C_{D_M} is the drag coefficient corresponding to the minimum power condition ($C_{D_i} = 3 C_{D_0}$).

- The slope of the drag curve at any given V_t becomes less positive as weight increases.
- The $C_{L_{max}}$ speed increases as weight increases. The locus of $C_{L_{max}}$ points on the $THP = f(V_t)$ curve is

$$THP_{CL} = \left[\frac{C_{D_S}}{1100} \rho_a S \right] V_t^3 \quad (31)$$

where C_{D_S} is the drag coefficient corresponding to the $C_{L_{max}}$

b. C_{D_0} Effect

The effect of a variation in C_{D_0} on the power equation is to change the K_1 term in the power equation

$$THP = K_1 V_t^3 + K_2 V_t^{-1} \quad (32)$$

where

$$K_1 = \frac{C_{D_0} \rho_{ssl} S}{1100}$$

We see that the K_1 change will be proportional to the C_{D_0} change. The change in total power will be the same as the change in parasite power (the induced power remains the same).

$$\Delta THP = \frac{\Delta C_{D_0} \rho_a S}{1100} V_t^3 \quad (33)$$

the effect of a change in C_{D_0} is illustrated in Figure 2A-14.

The effects of C_{D_0} are summarized below

- . The large power changes occur at the higher speeds and relatively low power changes occur at the low speeds.
- . The minimum power speed decreases as C_{D_0} increases. The locus of the minimum power points is

$$\text{THP}_{\min} = \frac{4}{3} \left[\frac{W^2}{275 \pi e A R S \rho_a} \right] V_t^{-1} \quad (34)$$

- . The slope of the $\text{THP} = f(V_t)$ curve is more positive at all speeds.

c. Altitude Effects

We will look at two methods to determine the effects of altitude on the $\text{THP} = f(V_t)$ curve.

METHOD I - We have already concluded that the $\text{THP}_e = f(V_e)$ does not change with altitude (see figure below). We also know that

$$V_t = \frac{V_e}{\sqrt{\sigma}}$$

and

$$\text{THP} = \frac{\text{THP}_e}{\sqrt{\sigma}}$$

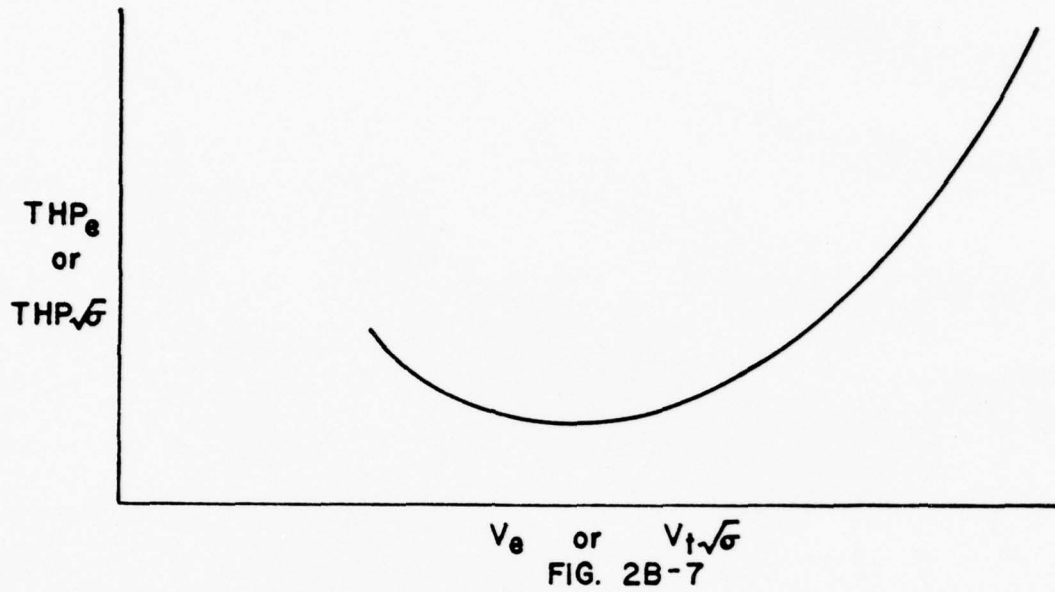

Thus any point (THP/σ and V_e) on the above power curve will correspond to a higher V_t ($V_t = V_e/\sqrt{\sigma}$) and higher THP ($THP = \frac{THP_e}{\sqrt{\sigma}}$) at higher density altitude. A plot of a power curve [$THP = f(V_t)$] standard sea level $\sigma = 1$ and then at a higher h_p (lower σ) as shown below.

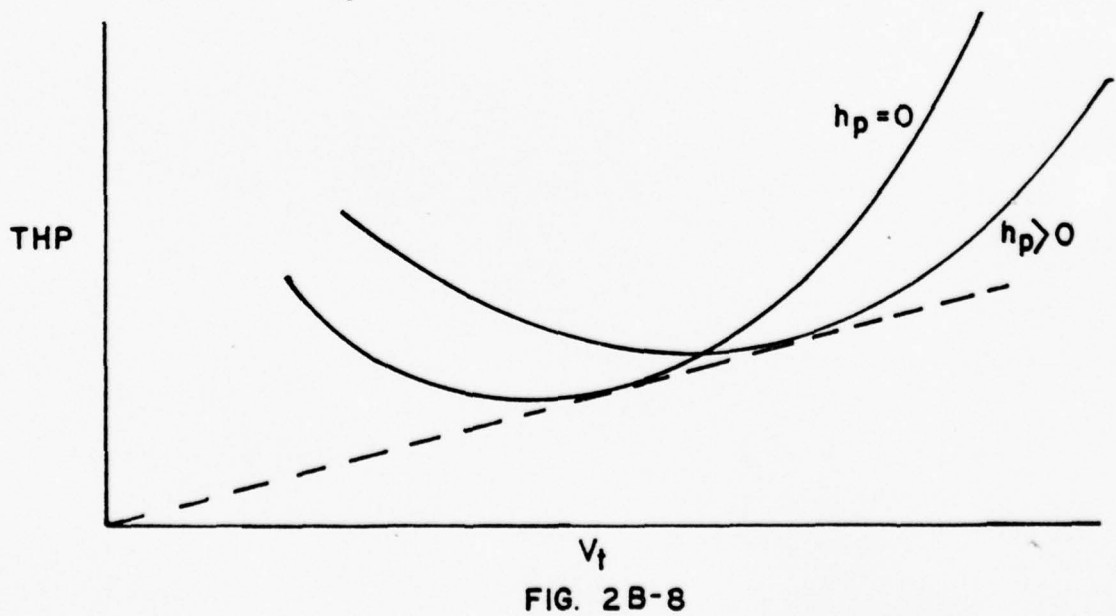

The altitude effects are summarized below

- . Any given point (THP_e and V_e) on the curve "shifts" to a higher speed (V_t) and power (THP) .
- . The minimum power point moves to a higher V_t and THP . (same THP_e and V_e)
- . If we assume no $C_{L_{max}}$ change [$C_{L_{max}} \neq f(R_n)$] and no thrust lift then the stall point shifts to a higher V_t and THP .

METHOD II - Another way to look at the effects of density changes on the

$THP = f(V_t)$ curve is to examine the $THP = f(V_t)$ equation.

The equation can be written as

$$THP = K_1 V_t^3 + K_2 V_t^{-1} \quad (35)$$

where

$$K_1 = \frac{C_{D0} \rho_a S}{1100}$$

and

$$K_2 = \frac{W^2}{275 \pi eAR S \rho_a S}$$

We see that density terms (ρ_a) appears in both the parasite and induced terms and that an increase in density altitude will

- decrease K_1

and

- increase K_2

A plot of the $THP = f(V_t)$ equation as ρ_a varies is shown in Figure 2B-9.

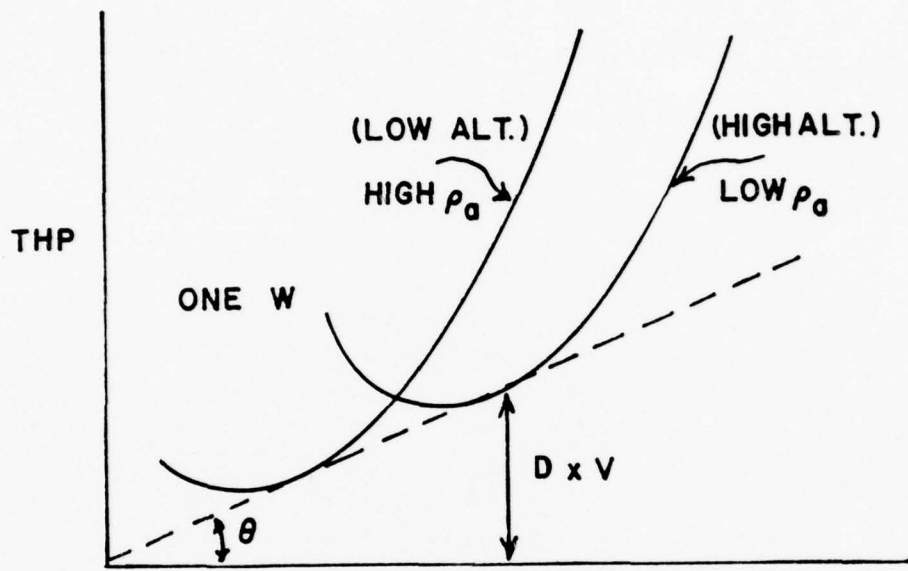

FIG. 2B-9

SUPPLEMENTARY PROBLEMS

Unit 2

1. The lift-independent drag coefficient (parasite drag coefficient) is sometimes computed on the basis of an "equivalent flat plate area" (f) because this portion of the drag is the same as the liftless drag of a flat plate of area f . An aircraft of a given cross-sectional area may have an equivalent flat plate area greater or smaller than the cross-sectional area of the aircraft because of the drag characteristics of the aircraft.
The non-dimensional parasite drag coefficient is equal to the equivalent flat plate area divided by the wing area ($C_D = f/S$).
What effect does doubling the equivalent flat^o plate area have on the lift coefficient at minimum thrust required for an aircraft with a parabolic drag polar?
2. For an aircraft with a parabolic drag polar, the minimum thrust required occurs when:
 - a. Parasite drag is a minimum.
 - b. Induced drag is a minimum.
 - c. Parasite drag equals induced drag.
 - d. The total drag is three times the induced drag.
3. On the "back side of the curve"
 - a. Thrust required decreases with increasing velocity.
 - b. Drag is a minimum.
 - c. Thrust required increase with increasing velocity.
 - d. Drag decreases as velocity decreases.
4. The effect of increasing altitude on the drag of an aircraft is such that:
 - a. The True velocity for minimum drag is a constant.
 - b. Minimum drag and the True velocity for minimum drag both increase.
 - c. Minimum drag is a constant and the True velocity for minimum drag increases.
 - d. Minimum drag is a constant and the True velocity for minimum drag increases.
5. The True velocity for minimum power required is:
 - a. The same as the True velocity for minimum drag.
 - b. Less than the True velocity for minimum thrust required.

- c. The same as the True velocity for minimum thrust required.
 - d. Greater than the True velocity for minimum thrust required.
6. At minimum thrust required, the induced drag coefficient is:
- a. One-half of the total drag coefficient.
 - b. Equal to three times the parasite drag coefficient.
 - c. Equal to one-third of the parasite drag coefficient.
 - d. Equal to twice the parasite drag coefficient.
7. For an aircraft with a parabolic drag polar, the minimum thrust required occurs at the point where:
- a. The square root of the cube of the lift coefficient is equal to the drag coefficient.
 - b. The ratio of the lift to the drag is the greatest.
 - c. The ratio of the lift to the drag is the smallest.
 - d. The ratio of the drag coefficient to the square root of the lift coefficient is the smallest.
8. A speed brake increases the parasite drag by 35%. This will have the greatest effect at:
- a. Minimum drag.
 - b. V_{MIN}
 - c. V_{MAX}
 - d. Minimum thrust required.

SUPPLEMENTARY PROBLEMS

SOLUTION SHEET

UNIT 2

1. Minimum drag occurs when $C_{D_o} = C_{D_i}$. Doubling the equivalent flat plate area is the same as doubling the parasite drag coefficient, since $C_{D_o} = f/S$.

If the parasite drag coefficient is doubled, the induced drag coefficient at minimum drag is also doubled (since the two drag components are equal at minimum drag). Now, since induced drag is a function of the square of the lift coefficient, doubling the induced drag must be accomplished by increasing the lift coefficient by a factor of the square root of two.

Check: $C_{D_{i_1}} = f (C_{L_1}^2)$

$$C_{D_{i_2}} = f (C_{L_2}^2) = f (C_{L_1} \sqrt{2})^2 = 2 \cdot f (C_{L_1})^2$$

and

$$C_{D_{i_2}} = 2 \cdot C_{D_{i_1}}$$

2. For a parabolic polar, $T = D = K_1 V^2 + K_2/V^2$ Eq. (18), 2A

Taking the derivative of the Thrust with respect to the velocity and setting equal to zero to determine the minimum point,

$$\frac{dT}{dV} = 2 K_1 V - 2 K_2/V^3 = 0$$

Multiplying both sides by V and dividing by 2 gives:

$$K_1 V^2 = K_2/V^2$$

The left hand term is the parasite drag and the right hand term is the induced drag, and it is shown that they are equal at minimum drag. The answer is

c. Parasite drag equals Induced drag

3. The "backside of the curve" is that portion below the velocity for minimum drag. It may be seen from Fig. 2A-9 that on the "backside of the curve", thrust required decreases as velocity increases. The answer is:

a. Thrust required decreases with increasing velocity.

4. Total drag may be written as:

$$D = C_{D_o} \frac{1}{2} \rho_a V_T^2 + \frac{2 W^2}{\pi e A R S \rho_a V_T^2}$$

The only variables in the above equation are ρ_a and V_T .

SUPPLEMENTARY PROBLEMS

SOLUTION SHEET

UNIT 2

(Cont)

4. (Continued)

After cross-multiplying, it is seen that

$$\left(\frac{V_T}{a} \right)^2 = \text{a constant}$$

The significance of this is that, at minimum drag, as the density decreases (altitude increases) the True air speed for minimum drag must increase.

In addition, if $\left(\frac{V_T}{a} \right)^2$ is a constant, the term $\left(\frac{V_T}{a} \right)^2$ must also be a constant, and both the induced drag and parasite drag (and therefore the total drag) remain constant at altitude. (See Fig. 2A-16)

The answer is:

c. Minimum drag is a constant and the True velocity for minimum drag increases.

5. Minimum power required occurs at that point on a drag polar where $C_{Di} = 3 C_{D0}$ (Eq. (24), 2-B). Recall that the point of minimum thrust is at $C_{Di} = C_{D0}$, and that parasite drag increases with velocity (Fig. 2A-9), so that if minimum power occurs when the induced drag is larger, it must occur at a lower velocity than that for minimum thrust. The answer is:

b. Less than the True velocity for minimum thrust required.

6. At minimum thrust required (minimum drag), the induced and parasite portions are equal (Problem 2). The answer is:

a. One-half of the total drag.

7. Since, for level flight, $D = C_D q S$ and $L = W = C_L q S$,

$$\frac{D}{L} = \frac{C_D q S}{C_L q S} = \frac{C_D}{C_L}$$

and

$$D = \frac{W}{C_L/C_D}$$

To minimize drag at a given weight, one must maximize C_L/C_D .

Check:

$$C_D = C_{D0} + K_2 C_L^2$$

and

$$\frac{C_D}{C_L} = \frac{C_{D0}}{C_L} + K_2 C_L$$

SUPPLEMENTARY PROBLEMS

SOLUTION SHEET

UNIT 2

(Cont)

7. (Continued)

To find the point of $(C_L/C_D)_{MAX}$, take the derivative with respect to C_L and set equal to zero.

$$\frac{d (C_L/C_D)}{d C_L} = - \frac{C_{D_o}}{C_L^2} + K_2 = 0$$

or

$$C_{D_o} = K_2 C_L^2 \text{ (Parasite equals induced)}$$

The answer is:

b. The ratio of the lift to the drag is the greatest.

8. The general effect of a change of parasite drag coefficient (C_{D_o}) is shown in Fig. 2A-14. Note that the effect of an increase in parasite drag is felt most at the higher velocities.

The answer is:

c. V_{MAX}

AE-2305

PERFORMANCE I

UNIT 3

Climb Performance, Descent Performance

PERFORMANCE I

Unit 3 - Climb Performance, Descent Performance

OBJECTIVES

As a result of your work in this Unit, you should be able to:

1. Draw a free-body diagram of an aircraft in unaccelerated climbing flight (Fig. 3A-2).
2. From the free-body diagram, derive the equation for rate of climb as a function of velocity, thrust, drag and weight. (Eq. (4), Section 3-A).
3. State the relationship between rate of climb at the maximum velocity for level flight at sea level and the rate of climb at absolute ceiling.
4. Express the total energy of an aircraft in terms of the aircraft's weight, mass, altitude and velocity.
5. For an aircraft with constant weight climbing at a constant velocity, show that the change of total energy with time ($d(TE)/dt$) is equal to the excess power available ($P_{ex} = TV - DV$).
6. Express the velocity for maximum rate of climb as a function of the power required for an aircraft with constant power available. (The approximate condition for a reciprocating engine aircraft).
7. Draw a free-body diagram of an aircraft in power-off glide and from this diagram derive the glide angle as a function of the lift and drag. (Fig. 3B-1).
8. State the lift-to-drag ratio for maximum distance glide.
9. Explain the effects of an increase in weight on glide ratio, glide distance and glide velocity.
10. Define Energy Height and explain why maximizing rate of energy height change with time is desired for an aircraft that is to climb to altitude and then proceed at a high velocity.

AE 2305
PERFORMANCE I

Unit 3

PROCEDURE

1. Read Sections 3-A and 3-B.
2. Memorize equations (4) and (6) in Section 3-a and equation (5) in Section 3-B.
3. Review the Statement of Objectives.
4. Answer the Study Questions.
5. Review the resource material as necessary, based on your difficulty with the Study Questions.

When you are ready, ask for the written test on this Unit. This test will be Closed Book. If equations, other than those listed to be memorized, are required, they will be furnished.

AE 2305

PERFORMANCE I

Unit 3

STUDY QUESTIONS

1. Two identical aircraft climb from a low altitude to an altitude well below their absolute ceiling and then accelerate to maximum velocity. Aircraft (A) climbs at maximum rate of climb and aircraft (B) climbs at maximum rate of energy climb. Which aircraft reaches the upper altitude first, which has the greater air speed in the climb, and which reaches V_{MAX} first?
2. An aircraft with a maximum lift-to-drag ratio equal to 15 enters a maximum range power-off glide at an altitude of 30,000 feet. Can this aircraft reach an airfield 78 miles away?
3. What is the effect of increasing the angle of glide from the angle for $(L/D)_{MAX}$ on the gliding distance? What is the effect of decreasing the angle of glide?
4. For an aircraft with constant thrust available, what is the relationship between the velocity for maximum rate of climb and the velocity for minimum thrust required? (Use a plot of thrust versus velocity to show your answer).
5. What is the maximum rate of climb in feet per minute for a 22,000 lb aircraft with a drag of 15,000 lbs, an available thrust of 17,000 lb and a velocity of 250 knots?
6. The NATOPS shows that your best glide velocity is 300 knots (Calibrated air speed) at a weight of 17,500 lbs. What is your best glide speed at a weight of 13,000 lb?
7. What is the ratio of the maximum glide distances for the two weights of Question 6?
8. If the maximum glide distance is obtained at an Equivalent air speed of 250 kts at an altitude of 5000 feet, what is the Equivalent air speed for maximum glide distance at an altitude of 25,000 feet?

PERFORMANCE I

Unit 3

STUDY QUESTIONS - SOLUTIONS

1. Aircraft A reaches altitude first
 Aircraft B climbs at a faster airspeed
 Aircraft B reaches V_{MAX} first.

$$2. \frac{\text{Distance}}{\text{Altitude}} = \frac{L}{D} = 15 \quad \text{Distance} = \frac{30,000 \text{ ft}}{5,280 \text{ ft/mi}} \times 15 = 85 \text{ miles}$$

Yes, the aircraft can glide the required distance.

3. Maximum rate of climb occurs where excess power is a maximum.

$$P_{ex} = P_{avail} - P_{req} = (T_{avail} \times V) - (T_{req} \times V)$$

If thrust available is a constant, maximum excess power available occurs where Thrust required is a minimum.

(Note that this is the case only if T_{avail} is a constant!)

4. Increasing angle of glide DECREASES gliding distance
 Decreasing angle of glide DECREASES gliding distance
 Optimum gliding distance is at the angle for $(L/D)_{MAX}$

$$5. \text{RC ft/min} = \frac{(T - D) \text{ lb} \times V \text{ ft/min}}{W \text{ lb}}$$

$$= \frac{(17,000 - 15,000) \text{ lb} \times 250 \text{ kts} \times 1.68894 \frac{\text{ft/sec}}{\text{kts}} \times 60 \frac{\text{min}}{\text{sec}}}{23,000 \text{ lb}}$$

$$= 2302 \text{ ft/min (check your units!)}$$

6. From Eq. 4, page 6, Section 3-B

$$\frac{V_2}{V_1} = \frac{W_2}{W_1} \quad \text{therefore} \quad V_2 = 300 \text{ kts} \times \frac{13,000 \text{ lb}}{17,500 \text{ lb}}$$

$$= 262 \text{ kts}$$

7. Ratio is the same for $(L/D)_{MAX}$
8. Same Equivalent airspeed - 250 kts.

UNIT 3-A

CLIMB PERFORMANCE

3A-1 GENERAL. The subject of climb performance can be a highly controversial subject. There is not much controversy over reduction of actual climb data to standard conditions, but there is considerable controversy over the methods of determining climb schedules. Most of the controversy centers around the worth of "sophisticated" methods as opposed to the "shotgun" methods. What is needed is a theoretical yet practical method for determining the schedule for minimum time to climb.

In discussing climb schedules, it is always necessary to preface any remarks with a statement as to what kind of a schedule is being discussed. Depending upon the particular mission of the airplane and, in fact, upon the particular mission of the flight to be flown, the optimum condition for climb will vary. An interceptor launching to take over a particular CAP station is primarily interested in climbing to his CAP altitude with the minimum expenditure of fuel. An interceptor launching to intercept an incoming raid will be primarily interested in arriving at the attack altitude with best fighting speed and in the minimum time. An attack aircraft launching on a strike mission will be primarily interested in climbing on a schedule of maximum range covered per pound of fuel burned. Still other types of missions may require or desire optimization of other factors during the climb.

3A-2. OPTIMIZED CLIMB PERFORMANCE

In a broad general look at the problem of climb performance, the problem consists of moving the airplane from a point of approximately zero altitude

and airspeed to an end condition representing some desired altitude (usually high) and airspeed. The mission will, of course, dictate the end condition or that point at which to transition from the climb phase to the level flight or maneuvering phase.

An initial point and some arbitrary end condition for the climb could be represented on a plot of altitude versus airspeed by points such as (A) and (B) on Figure 3A-1.

Points (A) and (B) can theoretically be connected by an infinite number of paths such as (1), (2), (3), (4) which would represent an infinite number of climb schedules. One of these infinite number of paths will represent an optimum path in regard to, say, minimum time to climb to point B. Another

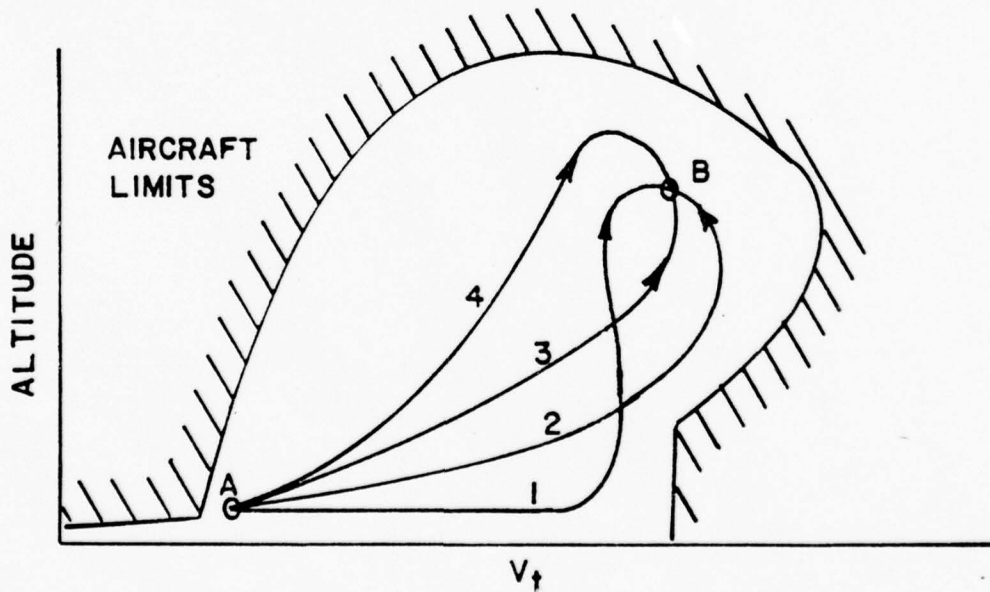

FIG. 3A-1

path will be optimum with respect to minimum fuel used. Still other paths will

represents optimization with respect to whatever variable we choose. The problem is to locate or identify these optimum paths.

The optimum path is naturally a function of the vehicle - its capabilities and its limitations. Superimposing the vehicle's flight envelope over the various paths will rule out many paths as impossible, but there will still be one possible path representing optimum conditions with respect to a desired variable.

It is possible to write equations describing any path between known end conditions, and by the methods of Variational Calculus to operate upon these equations to obtain equations for optimum paths. The equations are extremely complicated and require iterative solution by digital computing machines. The solution requires accurate inputs of engine, airframe and atmospheric data which must be obtained by flight test, but solutions are possible provided the data, patience and money are available to feed the computing machine.

3A-3. BASIC CONSIDERATIONS

During climbing flight, the airplane gains potential energy by virtue of elevation. This increase in potential energy during a climb is provided by one, or a combination of two means: (1) expenditure of propulsive energy above that required to maintain level flight or (2) expenditure of airplane kinetic energy, i.e., loss of velocity by a zoom. Zooming for altitude is a transient process of trading kinetic energy for potential energy and is of considerable importance for airplane configurations which can operate at very high levels of kinetic energy. However, the major portions of climb performance for most airplanes is a near steady process in which additional propulsive energy is converted into potential energy. The fundamental parts of airplane climb

performance involve a flight condition where the airplane is in equilibrium but not at constant altitude.

The forces acting on the airplane during a climb are shown by the illustration of Figure 3A-2.

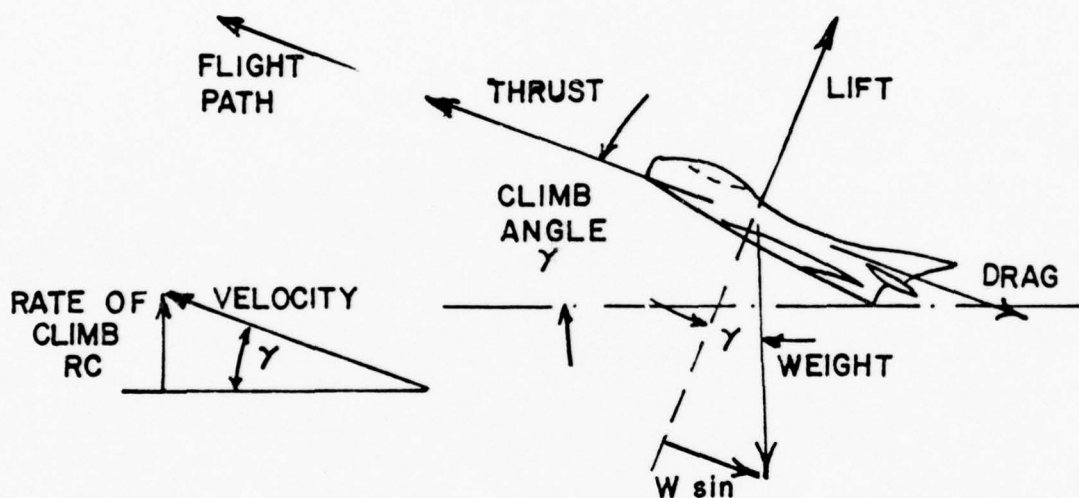

FIG. 3A-2

When the airplane is in steady flight with moderate angle of climb, the vertical component of lift is very nearly the same as the actual lift. Such climbing flight would exist with the lift very nearly equal to the weight. The net thrust of the powerplant may be inclined relative to the flight path but this effect will be neglected for the sake of simplicity. Note that the weight of the aircraft is vertical but a component of weight will act aft along the flight path.

If it is assumed that the aircraft is in a steady climb with essentially small inclination of the flight path, the summation of forces along the flight path resolves to the following:

Forces forward = Forces aft

$$T = D + W \sin\gamma \quad (1)$$

where

T = thrust available, lbs

D = drag, lbs.

W = weight, lbs.

γ = flight path inclination or angle of climb, degrees

This basic relationship neglects some of the factors which may be of importance for airplanes of very high climb performance. For example, a more detailed consideration would account for the inclination of thrust from the flight path, lift not equal to weight, subsequent change of induced drag, etc. However, this basic relationship will define the principal factors affecting climb performance. With this relationship established by the condition of equilibrium, the following relationship exists to express the trigonometric sine of the climb angle, :

$$\sin\gamma = \frac{T - D}{W} \quad (2)$$

This relationship simply states that, for a given weight airplane, the angle of climb (γ) depends on the difference between thrust and drag ($T - D$), or excess thrust. Of course, when the excess thrust is zero ($T - D = 0$ or $T = D$), the inclination of the flight path is zero and the

airplane is in steady, level flight. When the thrust is greater than the drag, the excess thrust will allow a climb angle depending on the value of excess thrust. Also, when the thrust is less than the drag, the deficiency of thrust will only allow an angle of descent.

The maximum angle of climb will occur where there exists the greatest difference between thrust available and thrust required, i.e., maximum $(T - D)$. Figure 3A-3 illustrates the climb angle performance with the curves of thrust available and thrust required versus velocity. The thrust required, or drag, curve is assumed to be representative of some typical airplane configuration which could be powered by either a turbojet or propeller type powerplant. The thrust available curves included are for a characteristic propeller powerplant and jet power-plant operating at maximum output.

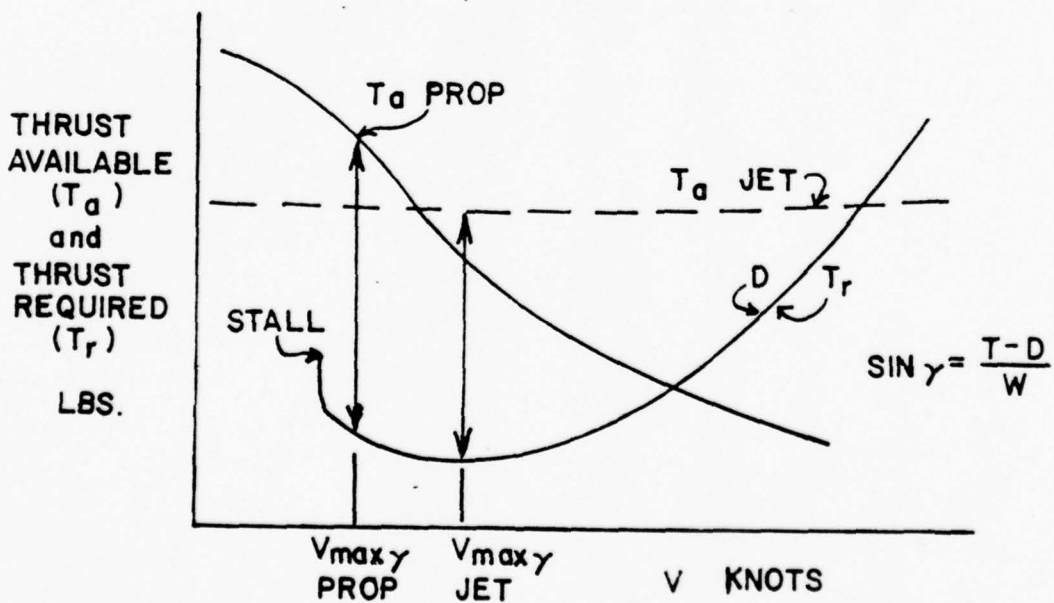

FIG. 3A-3

The thrust curves for the representative propeller aircraft show the typical propeller thrust which is high at low velocities and decreases with an increase in velocity. For the propeller powered airplane, the maximum excess thrust and angle of climb will occur at some speed just above the stall speed.

The thrust curves for the representative jet aircraft show the typical turbojet thrust which is very nearly constant with speed. If the thrust available is essentially constant with speed, the maximum excess thrust and angle of climb will occur where the thrust required is at a minimum, $(L/D)_{MAX}$. Thus, for maximum steady-state angle of climb, the turbojet aircraft would be operated at the speed for $(L/D)_{MAX}$.

Of great general interest in climb performance are the factors which affect the rate of climb. The vertical velocity of an airplane depends on the flight speed and the inclination of the flight path. In fact, the rate of climb is the vertical component of the flight path velocity. By the diagram of Figure 3A-2 the following relationship is developed:

$$RC = V \sin \gamma \quad (3)$$

since

$$\sin \gamma = \frac{T - D}{W}$$

then

$$RC = V \frac{(T - D)}{W} \quad (4)$$

and,

$$\text{with } Pa = \frac{TV}{33,000}$$

$$\text{and } Pr = \frac{DV}{33,000}$$

$$RC = 33,000 \left(\frac{Pa - Pr}{W} \right)$$

where

RC = rate of climb, ft/min

Pa = power available, h.p.

Pr = power required, h.p.

W = weight, lbs.

V = true airspeed, ft/min

and

33,000 is the factor converting horsepower to ft-lbs/min

The above relationship shows that, for a given weight airplane, the rate of climb (RC) depends on the difference between the power available and the power required ($P_a - P_r$), or excess power. Of course, when the excess power is zero ($P_a - P_r = 0$ or $P_a = P_r$), the rate of climb is zero and the airplane is in steady level flight. When the power available is greater than the power required, the excess power will allow a rate of climb specific to the magnitude of excess power. Also, when the power available is less than the power required, the deficiency of power produces a rate of descent. This relationship provides the basis for an important axiom of flight technique: "For the conditions of steady flight, the power setting is the primary control of rate of climb or descent".

One of the most important items of climb performance is the maximum rate of climb. By the previous equation for rate of climb, maximum rate of climb would occur where there exists the greatest difference between power available and power required, i.e., maximum ($P_a - P_r$). Figure 3A-4 illustrates the climb rate performance with the curves of power available and power required versus velocity. The power required curve is again a representative airplane

which could be powered by either a turbojet or propeller type powerplant. The power available curves included are for a characteristic propeller powerplant and jet powerplant operating at maximum output.

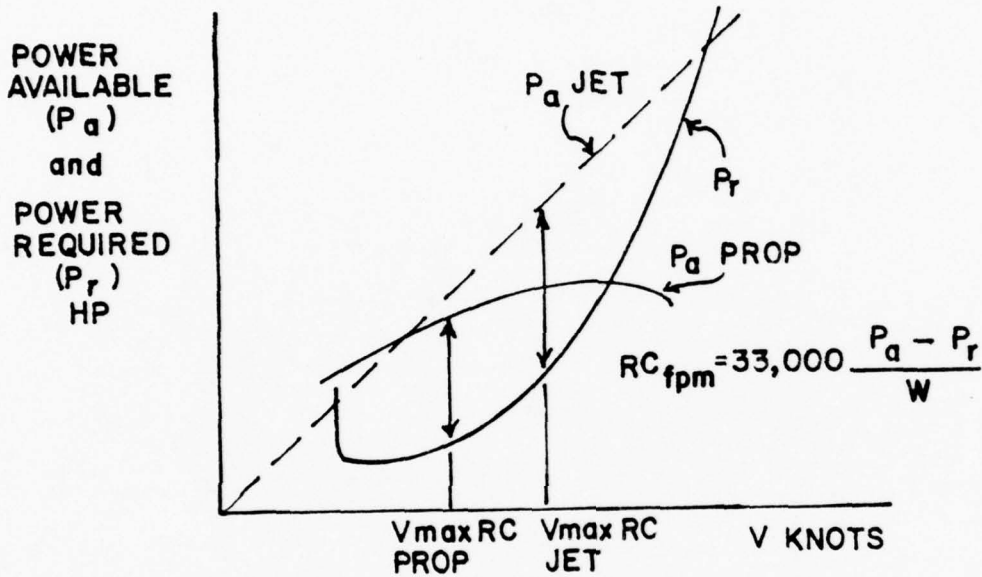

FIG. 3A-4

The power curves for the representative propeller aircraft show a variation of propulsive power typical of a reciprocating engine-propeller combination. The maximum rate of climb for this aircraft will occur at some speed near the speed for $(L/D)_{MAX}$.

The power curves for the representative jet aircraft show the near linear variation of power available with velocity. The maximum rate of climb for the typical jet airplane will occur at some speed much higher than that for maximum rate of climb of the equivalent propeller powered airplane. In part, this is accounted for by the continued increase in power available with speed.

The composite chart of climb performance depicts the variation with altitude of the speeds for maximum rate of climb, maximum angle of climb, and maximum and minimum level flight airspeeds. As altitude is increased, these various speeds finally converge at the absolute ceiling of the airplane. At the absolute ceiling, there is no excess of power or thrust and only one speed will allow steady level flight.

Specific reference points are established by composite curves of climb performance. First, the absolute ceiling of the airplane produces zero rate of climb. The service ceiling is specified as the altitude which produces a rate of climb of 100 fpm. The altitude which produces a rate of climb of 500 fpm is termed the combat ceiling. Usually, these specific reference points are provided for the airplane at the combat configuration or a specific design configuration.

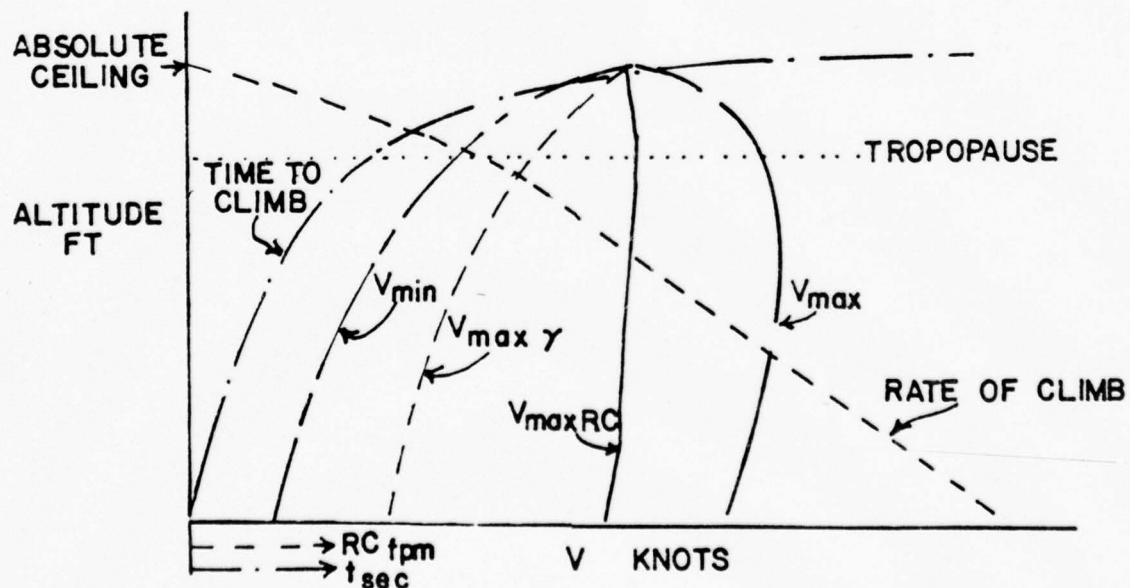

FIG. 3A-5

The composite curves of climb performance for the typical turbojet airplane are shown in Figure 3A-5. One particular point to note is the more rapid decay of climb performance with altitude above the tropopause. This is due in great part to the more rapid decay of engine thrust in the stratosphere.

3A-4. ENERGY APPROACH. Since the climb problem encompasses acceleration to an airspeed suitable for the particular mission of the flight as well as climbing to a particular altitude, consideration of the climb from an energy standpoint is advisable. The energy that we are concerned with is mechanical energy. It consists of two types. Potential energy is the energy of position and is representative of the altitude of the plane. Kinetic energy is the energy of motion and is representative of the speed of the plane. We will call the sum of potential and kinetic energy total energy.

We will approach the climb problem by minimizing the time or the fuel required to advance from one total energy level to another. This total energy level will be determined by summing the potential energy and kinetic energy of the airplane's position and speed.

Total Energy = Potential Energy + Kinetic Energy

$$TE = PE + KE \quad (5)$$

or

$$TE = Wh + \frac{1}{2} \frac{W}{g} V^2 \quad \frac{W}{g} = M \text{ (Mass)} \quad (6)$$

To minimize time between energy levels we wish to maximize the rate of change of total energy. As a first step, let us differentiate the total energy equation with respect to time

$$\frac{d(TE)}{dt} = W \frac{dh}{dt} + \frac{W}{g} V \frac{dV}{dt} + h \frac{dW}{dt} + \frac{V^2}{2g} \frac{dW}{dt} \quad (7)$$

If we analyze the order of magnitude of the terms in (7) for a representative airplane we will find that the two terms containing dW/dt will be small in relation to the other terms. The dW/dt terms are particularly small in non-afterburning airplanes and can almost always be neglected. In afterburning airplanes the two dW/dt terms may possibly be significant enough that they cannot be neglected. In present day aircraft, however, under the most adverse conditions (at slow speed and low altitude) the dW/dt terms generally do not represent more than 5-7% of the total energy and can be neglected without introducing excessive errors. Thus we can reduce equation (7) to the following:

(assuming $\frac{dW}{dt} = 0$)

$$\frac{d(TE)}{dt} = W \frac{dh}{dt} + \frac{WV}{g} \frac{dV}{dt} \quad (8)$$

Before proceeding with the energy equation let's stop for a moment and look at the forces acting along the flight path of a climbing airplane.

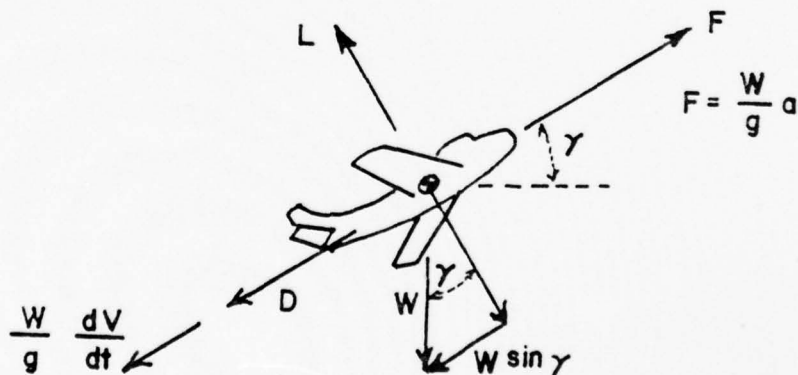

FIG. 3A-6

Noting the forces along the flight path in Figure 3A-6, we see that the thrust force, (F) , is opposed by the drag, (D) , a component of the weight, $(W \sin \gamma)$, and the force required to accelerate the airplane linearly, $(\frac{W}{g} \frac{dV}{dt})$. (Assuming that the angle of attack of the thrust axis is zero). Thus

$$F = D + W \sin \gamma + \frac{W}{g} \frac{dV}{dt} \quad (9)$$

Solving equation (9) for dV/dt

$$\frac{dV}{dt} = \frac{g}{W} (F - D - W \sin \gamma) \quad (10)$$

Also noting that

$$V \sin \gamma = dh/dt \quad (\text{vertical velocity}) \quad (11)$$

We may substitute equations (10) and (11) into (8)

$$\frac{d(\text{TE})}{dt} = W V \sin \gamma + \frac{W}{g} V \frac{g}{W} (F - D - W \sin \gamma) \quad (12)$$

and

$$\frac{d(\text{TE})}{dt} = VF - VD \quad (13)$$

Equation (13) says that rate of change of total energy is equal to excess power or is proportional to excess thrust horsepower. This means that the difference between the power available and the power required for an airplane at a given speed and altitude, which is called excess power, is equal to the rate of change of total energy at that speed and altitude. Figure 3A-7 illustrates this graphically.

The excess power which is available over that required to maintain level flight at a given altitude and speed is power which is available for climbing or maneuvering the airplane. It is this quantity which must be measured by

flight test at various speeds and altitudes in order to determine recommended climb schedules.

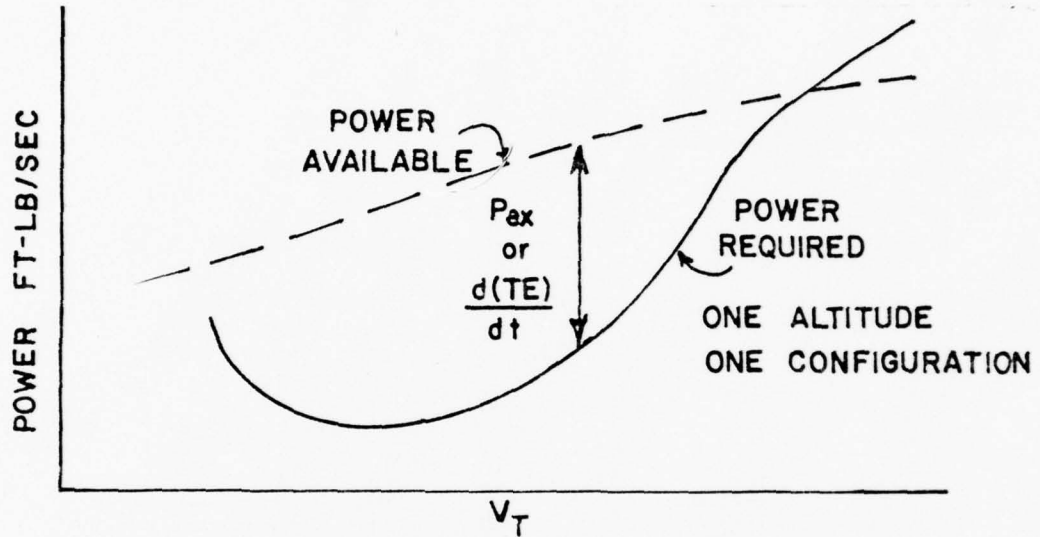

FIG. 3A-7

To see how to measure excess power or rate of change of total energy look at equation (8). First of all note that there is a weight factor in each term on the right side of the equation. We have assumed that weight can be considered constant, so divide both sides of the equation by weight. In doing so a new term is defined - specific energy (E_h). Specific energy is total energy per unit of weight with units of $\frac{\text{lb ft}}{\text{lb}}$.

$$E_h = \frac{(TE)}{W} \quad (14)$$

Dividing equation (8) by weight gives an equation for rate of change of specific energy in units of ft/sec.

$$\frac{dE_h}{dt} = \frac{dh}{dt} + \frac{V}{g} \frac{dV}{dt} \quad (15)$$

Equation (15) says that rate of change of specific energy is the sum of the rate of climb, (dh/dt) , and the term $\frac{V}{g} \frac{dV}{dt}$. Determination of dE_h/dt by flight test could be accomplished by holding dh/dt equal to zero, i.e. level flight, and measuring velocity and acceleration or by maintaining a constant true airspeed ($dV/dt = 0$) and measuring rate of climb. These two procedures are the basis for the level flight acceleration run technique and the sawtooth climb technique respectively for collecting climb performance data. There are other methods of measuring excess power or dE_h/dt but the two methods mentioned above are the primary ones in use.

3A-5. ESTABLISHMENT OF CLIMB SCHEDULES

The data collected from acceleration runs, sawtooth climbs or whatever method is used can now be plotted on a composite plot of rate of change of specific energy (dE_h/dt) or excess thrust horsepower versus true airspeed. This plot will have curves of dE_h/dt versus true airspeed corrected to standard weight for each altitude at which data was collected. This plot will be similar to Figure 3A-8.

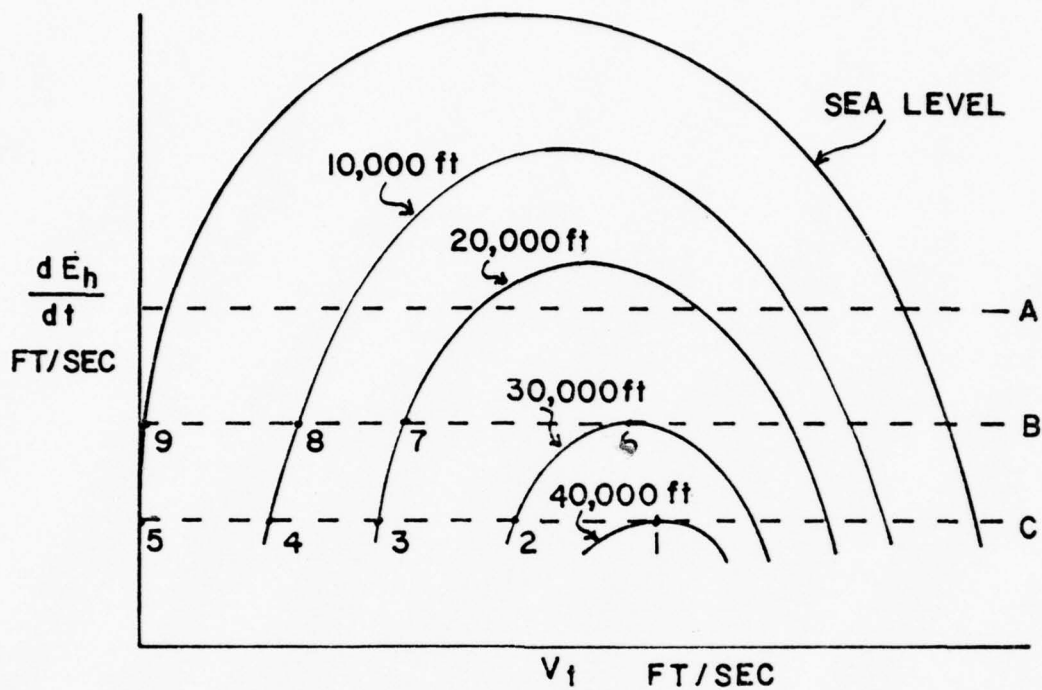

FIG. 3A-8

The data from Figure 3A-8 can be cross-plotted on coordinates of altitude and true airspeed for lines of constant rate of change of specific energy. The construction lines A, B, and C shown on Figure 3A-8, for example, would cross-plot as curves A, B, and C on Figure 3A-9.

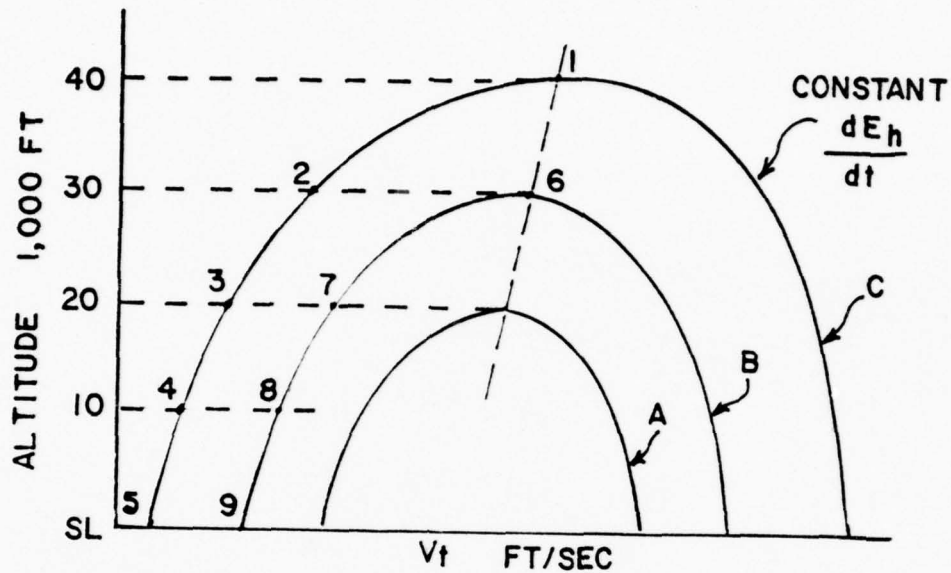

FIG. 3A-9

To be absolutely correct, the altitude data should be corrected to standard altitude before cross-plotting. Cross-plotting as many curves of constant dE_h/dt on h and V_t coordinates as can be well defined from the data will result in more clearly defined climb schedules.

The peaks of the curves of Figure 3A-8 with respect to the vertical axis will cross-plot as the peaks of the curves of figures 3A-9 as noted for points (1) and (6). A climb schedule based upon these vertical peaks would represent the speed at which maximum excess thrust horsepower occurs at each altitude. This speed will also represent the stabilized speed at which the airplane would experience the greatest rate of climb in passing through that altitude.

Prior to the advent of total energy concepts, climb schedules were based upon these vertical peaks.

The vertical peaks normally occur at increasing true airspeeds at increasing altitudes. This requires acceleration of the airplane along its flight path. To accelerate the airplane requires excess thrust or power. Thus the excess thrust horsepower available from the engine under any given set of conditions must be split between the requirements of climbing and of accelerating. Both climbing and accelerating, however, will increase the total mechanical energy of the airplane ($E_h = h + \frac{V^2}{2g}$).

This is a favorable condition. In most climbing situations one is more interested in climbing to altitude and accelerating to best combat speed than in just reaching a given altitude. In other words, one is more interested in increasing total energy than in just increasing altitude.

The schedule based upon the vertical peaks will not give the airplane the maximum rate of increase of total energy. If, however, lines of constant specific energy ($h + \frac{V^2}{2g}$, sometimes called "energy height" or "energy altitude") are plotted on the coordinates of Figure 3A-9, a new set of coordinates which is a measure of total energy is established. Now, the peaks of the lines of constant rate of change of specific energy with respect to levels of total energy will give a schedule for maximum rate of increase of total energy. See Figure 3A-10.

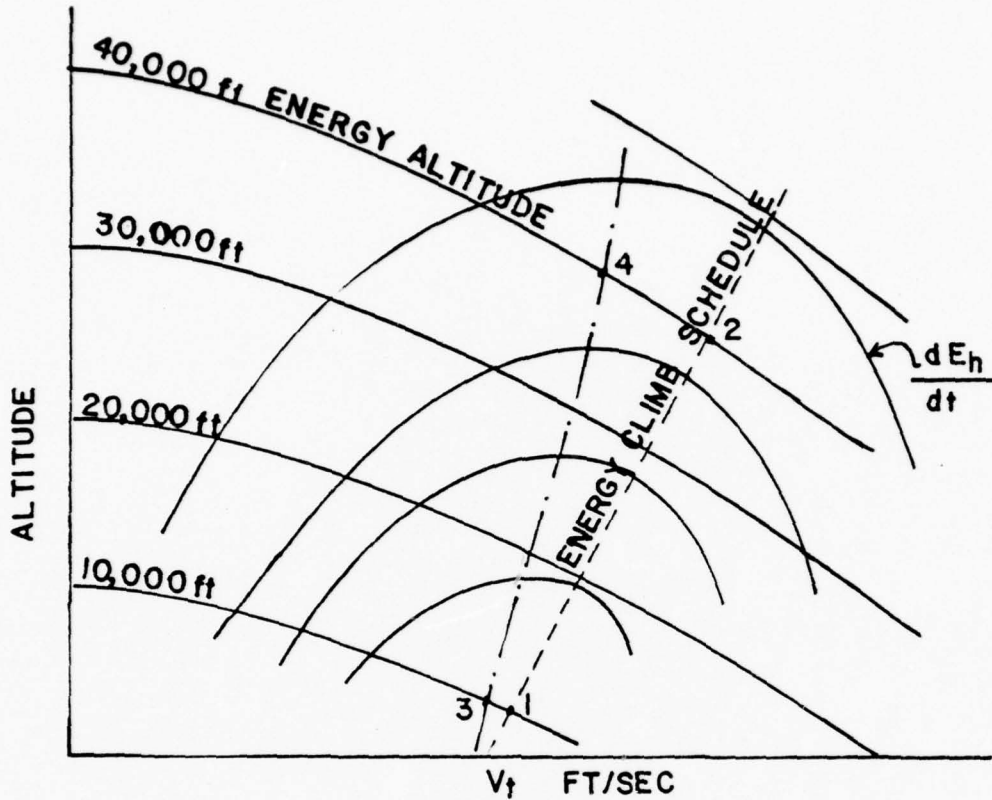

FIG. 3A-10

The energy climb schedule, as it is popularly named, is not the answer to every climb problem, but it is an improvement over previous schedules and does have a wide area of applicability. The energy climb schedule gives a path defined by airspeed and altitude for transitioning from one energy level to a higher energy level in the minimum period of time. The energy schedule represented by moving from point (1) to point (2) on Figure 3A-10 will get an airplane from the 10,000 ft energy altitude level to the 40,000 foot energy altitude level faster than any other schedule such as (3) to (4). The energy

schedule will not, however, get an airplane from one point such as (3) to another point such as (4) in the minimum period of time unless those points lie on the energy schedule, such as points (1) and (2). To optimize the time of transit from given initial conditions, such as take-off, to given end conditions, such as intercept speed and altitude, requires the more sophisticated mathematical approach of variational calculus.

For transition between widely separated energy levels, however, the energy climb schedule normally approaches the optimum path and is recommended for jet climbs to high altitudes.

Actual methods of determining recommended climb schedules vary greatly throughout the aircraft industry. The most popular method appears to be the "shotgun" method. This method involves flying a great number of random type schedules and picking a best schedule based upon flight test results. This method is easy since most jet flights will be carried to high altitude and there is ample opportunity to try various schedules. The worth of the "shotgun" method depends upon the procedures used to determine the various schedules to be tested. If the trial schedules are determined by skill and science rather than by ignorance and superstition, the shotgun approach provides a certain refinement and probably will produce a recommended schedule which is, in fact, optimum. For example, a trial schedule based upon acceleration run or sawtooth climb data which was then refined by "shotgunning" would most probably be a good schedule. Initial schedules based upon estimated excess thrust horsepower data would be less accurate and those based upon only an "artistic sense" would be extremely poor.

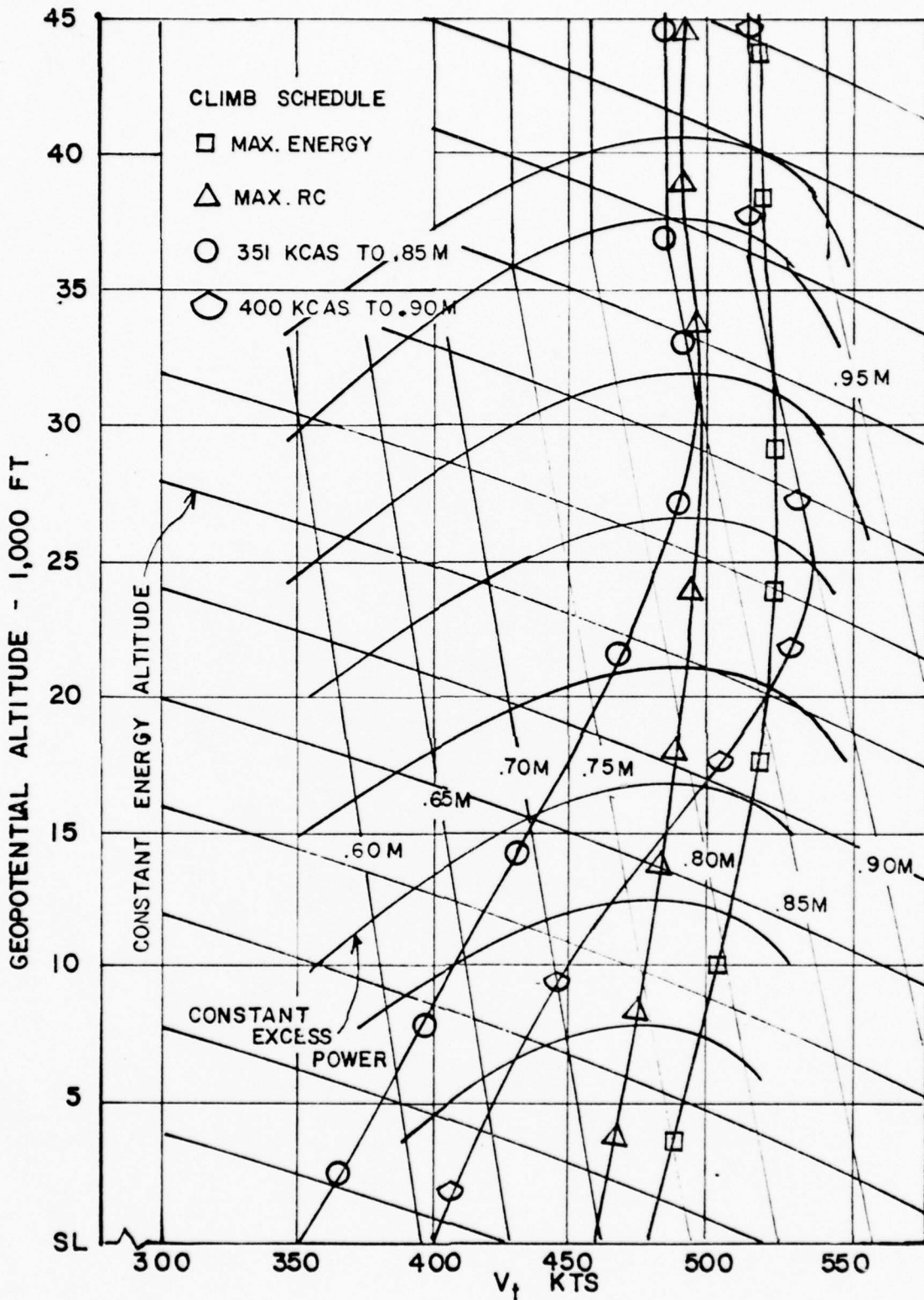

T-38A
FIG. 3A-II

Figure 3A-11 shows four actual climb schedules evaluated for the T-38A aircraft. Two schedules show a constant airspeed to constant Mach number flight path, one a maximum rate of climb flight path, and one a maximum energy climb. From a side by side comparison of climb schedules such as presented in Figure 3A-11, optimum flight profiles may be chosen for a particular mission.

Up to this point we have discussed the determination of climb schedules which represent the minimum time to climb. As was mentioned early in the chapter, for many type missions, basic variables other than time are of paramount interest. In section 3A-4, we discussed the energy approach to climb performance, but we restricted our discussion to time rates of change of energy. In an analagous manner, we could have discussed rates of change of total energy per pound of fuel consumed. This would have involved differentiation of specific energy with respect to change of aircraft gross weight (due to burning fuel).

$$\frac{dE_h}{dW} = \frac{d}{dW} \left(h + \frac{V^2}{2g} \right) = \frac{dh}{dW} + \frac{V}{g} \frac{dV}{dW}$$

Change in altitude per pound of fuel used dh/dW in sawtooth climbs or change in airspeed per pound of fuel dV/dW in acceleration runs would equal change in specific energy with respect to fuel used. Then, curves of constant dE_h/dW drawn on energy coordinates would yield a minimum fuel to energy altitude schedule.

A climb schedule which will yield maximum specific range during the climb will be fairly similar to an energy climb schedule. We are interested in achieving a maximum range for a minimum fuel expenditure during a climb to a desired altitude and end speed. From that altitude and end speed, the cruise climb portion of the flight would commence.

Ideally, the range problem can be solved mathematically for an optimum path from point of take-off to destination by the techniques of Variational Calculus in a manner similar to the discussed in section 3A-2. The ideal approach would involve only one phase or path - take-off to destination. The procedures for maximum range flight commonly used, however, involve three phases - climb, cruise and descent - and require individual optimization of each phase. This chapter is concerned with optimization of the climb phase.

If the desired end point of the climb phase of the max range problem (and thus the initial point of the cruise phase) is at an airspeed similar to the climb speed for an energy "minimum fuel" climb, then the minimum fuel climb will very closely approximate the no-wind maximum miles per pound schedule. This is shown on Figure 3A-12.

Since the initial point of the cruise climb is defined by an altitude and an airspeed for a particular gross weight, the schedule which gets you to that energy level represented by those conditions with the minimum fuel expenditure will be very close to the optimum schedule.

Wind will affect the climb phase in a manner analagous to its effect on the cruise phase. For a headwind component an incremental increase in speed for the climb schedule will slightly improve range characteristic provided the peak of the dE_h/dW curve with respect to energy altitude is not too sharp. For a tailwind component an incremental decrease in speed will increase range over the no-wind scheduled speed.

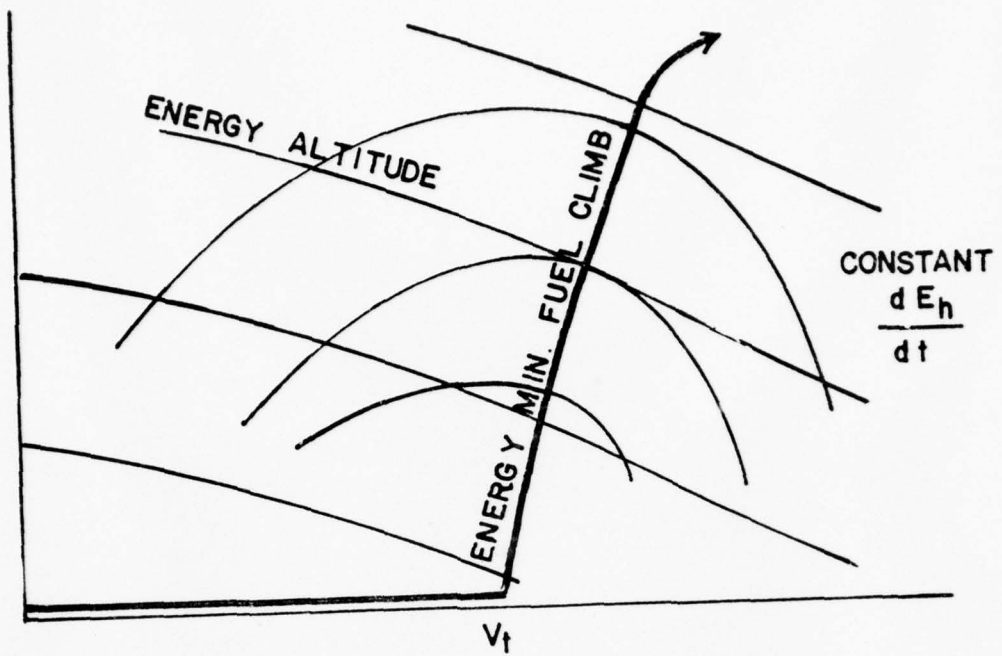

FIG. 3A-12

Unit 3-B

Descent Performance

3B-1. INTRODUCTION

In the study of climb performance, the forces acting on the airplane in a steady climb (or glide) produce the following relationship:

$$\sin\gamma = \frac{T - D}{W} \quad (1)$$

where

γ = angle of climb, degrees

T = thrust, lbs.

D = drag, lbs.

W = lbs.

In the case of power-off descent or glide performance, the thrust, T, is zero and the relationship reduces to:

$$\sin\gamma = - \frac{D}{W} \quad (2)$$

By this relationship it is evident that the minimum angle of glide - or minimum negative climb angle - is obtained at the aerodynamic conditions which incur the minimum total drag. Since the airplane lift is essentially equal to the weight, the minimum angle of glide will be obtained when the airplane is operated at maximum lift-drag ratio, $(L/D)_{MAX}$. When the angle of glide is relatively small, the ratio of glide distance to glide altitude is numerically equal to the airplane lift-drag ratio.

$$\text{glide ratio} = \frac{\text{glide distance, ft.}}{\text{glide altitude, ft.}} = \frac{L}{D} \quad (3)$$

Figure 3B-1 illustrates the forces acting on the airplane in a power-off glide. The equilibrium of the steady glide is obtained when the summation of

forces in the vertical and horizontal directions is equal to zero.

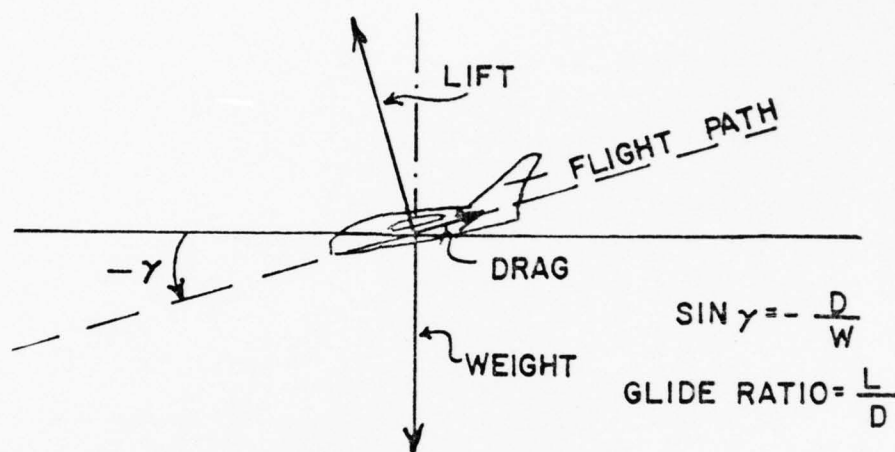
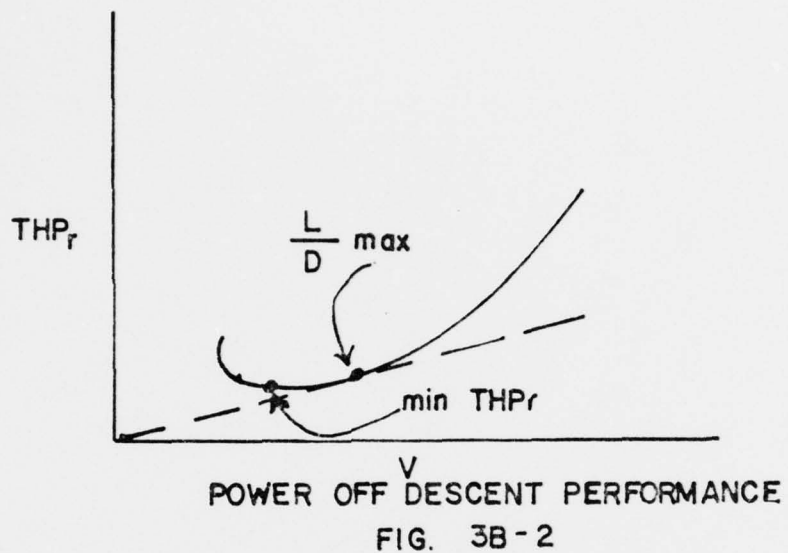

FIG. 3B-1

During a power off descent the deficiency of thrust and power define the angle of descent and rate of descent. Two particular points are of interest during a power-off descent: minimum angle of descent and minimum rate of descent. The minimum angle of descent would provide maximum glide distance through the air. Since no thrust is available from the power plant, minimum angle of descent would be obtained at $(L/D)_{MAX}$. At $(L/D)_{MAX}$ the deficiency of thrust is a minimum and, as shown by figure 3B-2, the greatest proportion between velocity and power required is obtained. The minimum rate of descent in power-off flight is obtained at the angle of attack and airspeed which produce minimum power required.



In order to obtain maximum glide ratio, the airplane must be operated at the angle of attack and lift coefficient which provide maximum lift-drag ratio. The illustration of figure 3B-3 depicts a variation of lift-drag ratio, L/D , with lift coefficient, C_L , for a typical airplane in the clean and landing configurations. Note that $(L/D)_{MAX}$ for each configuration will occur at a specific value of lift coefficient and, hence, a specific angle of attack.

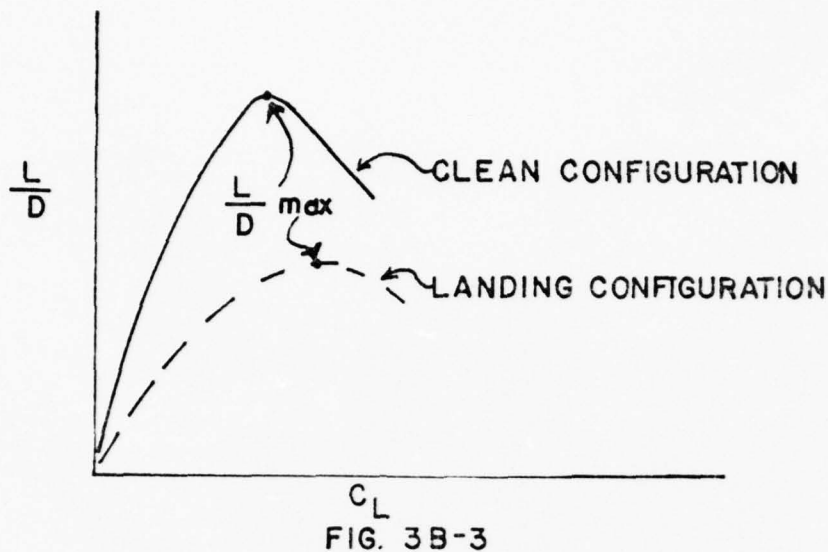
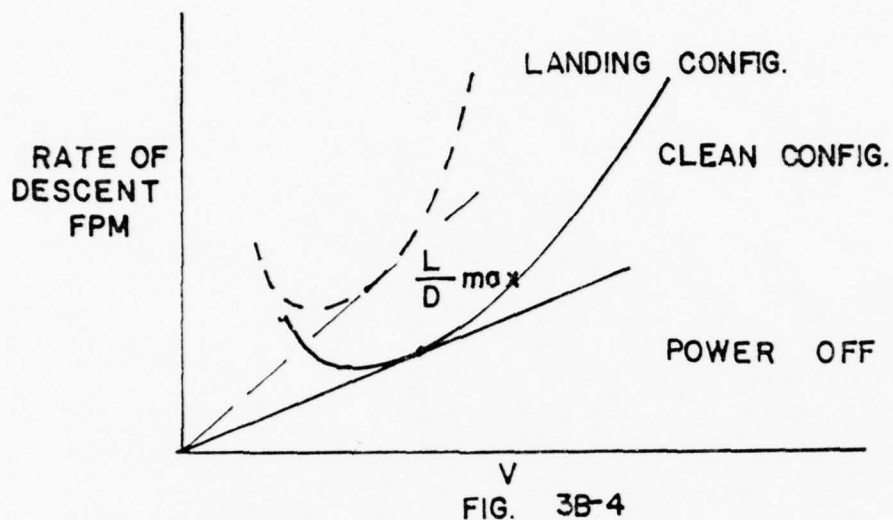

FIG. 3B-3

Thus, the maximum glide performance of a given airplane configuration will be unaffected by gross weight and altitude when the airplane is operated at $(L/D)_{\text{MAX}}$. Of course, an exception occurs at very high altitudes where compressibility effects may alter the aerodynamic characteristics. The highest value of (L/D) will occur with the airplane in the clean configuration. As the airplane is changed to the landing configuration, the added parasite drag reduces $(L/D)_{\text{MAX}}$ and the C_L which produces $(L/D)_{\text{MAX}}$ will be increased. Thus, the best glide speed for the landing configuration generally will be less than the best glide speed for the clean configuration.

The power-off glide performance may be appreciated also by the graph of rate of descent versus velocity shown in figure 3B-4. When a straight line is drawn from the origin tangent to the curve, a point is located which produces the maximum proportion of velocity to rate of descent. Obviously, this condition provides maximum glide ratio. Since the rate of descent is proportional to the power required, the points of tangency define the aerodynamic condition of $(L/D)_{\text{MAX}}$.



3B-2. PARAMETERS IN DESCENT PERFORMANCE

In order to obtain the minimum glide angle through the air, the airplane must be operated at $(L/D)_{MAX}$. The subsonic $(L/D)_{MAX}$ of a given airplane configuration will occur at a specific value of lift coefficient and angle of attack. However, as can be noted from the curves of figure 3B-3, small deviations from the optimum C_L will not cause a drastic reduction of (L/D) and glide ratio. In fact, a 5 percent deviation in speed from the best glide speed will not cause any significant reduction of glide ratio. This is fortunate and allows the specifying of convenient glide speeds which will be appropriate for a range of gross weights at which power-off gliding may be encountered, e.g., small quantities of fuel remaining.

An attempt to stretch a glide by flying at speeds above or below the best glide speed will prove futile. As shown by the illustration of figure

3B-3, any C_L above or below the optimum will produce a lift-drag ratio less than the maximum. If the airplane angle of attack is increased above the value for $(L/D)_{MAX}$, a transient reduction in rate of descent will take place but this process must be reserved for the landing phase. Eventually, the steady-state conditions would be achieved and the increased angle of attack would incur a lower airspeed and a reduction in (L/D) and glide ratio.

The effect of gross weight on glide performance may be difficult to appreciate. Since $(L/D)_{MAX}$ of a given airplane configuration will occur at a specific value of C_L , the gross weight of the airplane is operated at the optimum C_L . Thus, two airplanes of identical aerodynamic configuration but different gross weight would glide the same distance from the same altitude. Of course, this fact would be true only if both airplanes are flown at the specific C_L to produce $(L/D)_{MAX}$. The principal difference would be that the heavier airplane must fly at a higher airspeed to support the greater weight at the optimum C_L . In addition, the heavier airplane flying at the greater speed along the same flight path would develop a greater rate of descent.

The relationship which exists between gross weight and velocity for a particular C_L is as follows:

$$\frac{V_2}{V_1} = \sqrt{\frac{W_2}{W_1}} \quad (\text{constant } C_L) \quad (4)$$

where

V_1 = best glide speed corresponding to some original gross weight, W_1

V_2 = best glide speed corresponding to some new gross weight, W_2

As a result of this relationship, a 10 percent increase in gross weight would require a 5 percent increase in glide speed to maintain $(L/D)_{MAX}$. While small variations in gross weight may produce a measurable change in best glide speed, the airplane can tolerate small deviations from the optimum C_L without significant change in (L/D) and glide ratio. For this reason, a standard single value of glide speed may be specified for a small range of gross weights at which glide performance can be of importance. A gross weight which is considerably different from the normal range will require a modification of best glide speed to maintain the maximum glide ratio.

The effect of altitude on glide performance is insignificant if there is no change in $(L/D)_{MAX}$. Generally, the glide performance of the majority of airplanes is subsonic and there is no noticeable variation of $(L/D)_{MAX}$ with altitude. Any specific airplane configuration at a particular gross weight will require a specific value of dynamic pressure to sustain flight at the C_L for $(L/D)_{MAX}$. Thus, the airplane will have a best glide speed which is a specific value of equivalent airspeed independent of altitude. For convenience and simplicity, this best glide speed is specified as a specific value of indicated airspeed and compressibility and position errors are neglected. The principal effect of altitude is that at high altitude the true airspeed and rate of descent along the optimum glide path are increased above the low altitude conditions. However, if $(L/D)_{MAX}$ is maintained, the glide angle and glide ratio are identical to the low altitude conditions.

The effect of configuration has been noted previously in that the addition of parasite drag by flaps, landing gear, speed brakes, external stores, etc. will reduce the maximum lift-drag ratio and cause a reduction of glide ratio.

In the case where glide distance is of great importance, the airplane must be maintained in the clean configuration and flown at $(L/D)_{MAX}$.

The effect of wind on gliding performance is similar to the effect of wind on cruising range. That is, a headwind will always reduce the glide range and a tailwind will always increase the glide range. The maximum glide range of the airplane in still air will be obtained by flight at $(L/D)_{MAX}$. However, when a wind is present, the optimum gliding conditions may not be accomplished by operation at $(L/D)_{MAX}$. For example, when a headwind is present, the optimum glide speed will be increased to obtain a maximum proportion of ground distance to altitude. In this sense, the increased glide speed helps to minimize the detrimental effect of the headwind. In the case of a tailwind, the optimum glide speed will be reduced to maximize the benefit of the tailwind. For ordinary wind conditions, maintaining the glide speed best for zero wind conditions will suffice and the loss or gain in glide distance must be accepted. However, when the wind conditions are extreme and the wind velocity is large in comparison with the glide speed, e.g., wind velocity greater than 25 percent of the glide speed, changes in the glide speed must be made to obtain maximum possible ground distance.

3B-3. CALCULATION OF DESCENT SCHEDULES

Descent performance can be developed into a field in itself which would include such things as the determination of airspeeds which maximize time aloft under dead stick conditions, optimum range/fuel consumption schedules in descent, etc. One very practical problem in descent is the determination of a recommended airspeed schedule for maximum range glide in a jet airplane under a flamed-out situation.

It was mentioned previously that an airframe has one angle of attack at which C_L/C_D is a maximum and that while gliding at this optimum angle of attack range in glide was maximized. (At a given angle of attack, C_L/C_D EQUALS GLIDE RATIO). To say this, we ignore variations in trim drag associated with large CG shifts and the effects of M and R_N on the shapes of the C_L and C_D curves.

This optimum angle of attack is independent of airplane gross weight. If an airplane is at this optimum angle of attack, the glide angle is minimized.

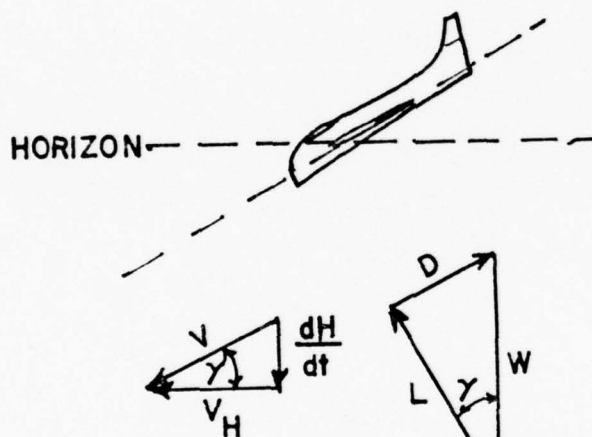

FOR A FIXED L/D RATIO,
 γ IS A CONSTANT, NO
 MATTER WHAT THE
 WEIGHT.

FIG. 3B-5

This brings up some interesting thoughts. If weight is increased, the vectors L and D must be longer. This means higher airplane speeds. In other words, If you are heavy at flame-out, you must hold a faster indicated speed to hit the optimum angle of attack. Once at this angle of attack, your gliding range is just as great from a given altitude as it would be at the optimum angle of attack if you were light. Your rate of descent will be

greater in the heavy case, of course, but your increased forward speed cancels this out. This means that in theory if you had to make a field upwind from you, your glide range will be greater with tip fuel still aboard than without it since the wind will have less time to act. By jettisoning fuel, however, you gain time to attempt a relight and, of course, have obvious advantages in effecting the landing what with lower stalling speeds, etc. (The idea of keeping fuel aboard is brought up at only a physics problem and no changes to sound operating procedure are implied).

The problem becomes finding a schedule of indicated airspeed vs. altitude (or an approximate fixed V_1) which will give maximum range in glide. A weight correction thumb rule may be practical (i.e., increased glide speed so many knots for every 1000 pound over a standard weight).

One method of obtaining a descent schedule is to make several power off descents holding a constant V_c and recording altitude vs. time in descent. OAT is likewise recorded at various altitudes. The resulting plot will look like this

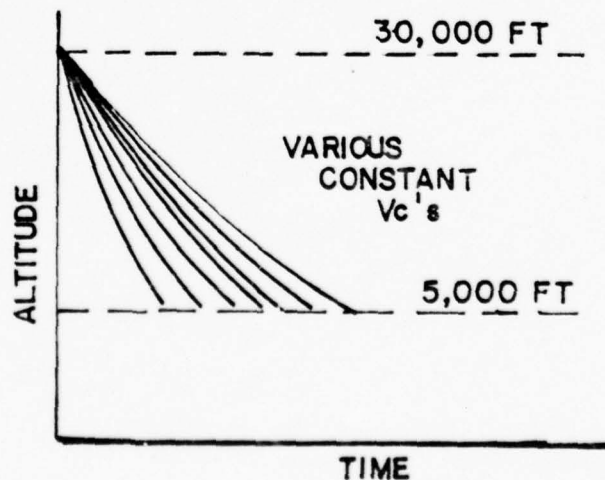

FIG. 3B-6

This plot is then differentiated to give values of dh/dt at various altitudes for each value of V_c . A table is made up for each V_c :

$V_c = 170$	Altitude	$\frac{dh}{dt}$	$\frac{V_c}{\sqrt{\theta}}$	$\frac{V_T}{\frac{dh}{dt}}$
				Glide ratio
	30,000	xxxx ft/min	xxxx ft/min	xx
	28,000	xxxx ft/min	xxxx ft/min	xx
	26,000	xxxx ft/min	xxxx ft/min	xx
	etc.	xxxx ft/min	xxxx ft/min	xx

(Since glide angles are normally less than 15%, $\sin \gamma$ is assumed to equal $\tan \gamma$).

Once this data has been accumulated for all test V_c 's, the following plot can be constructed for each altitude:

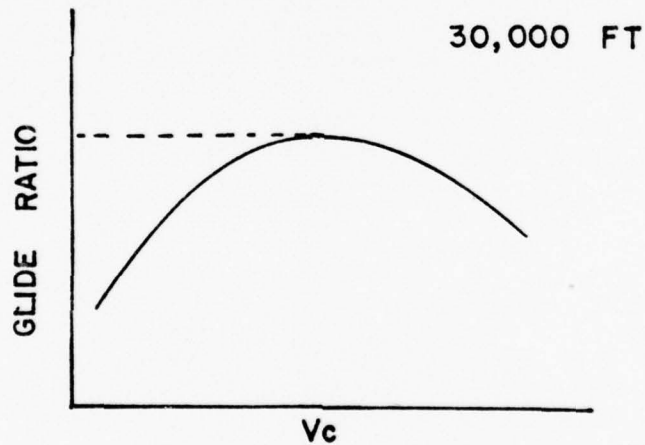

FIG. 3B-7

The following plot can then be constructed:

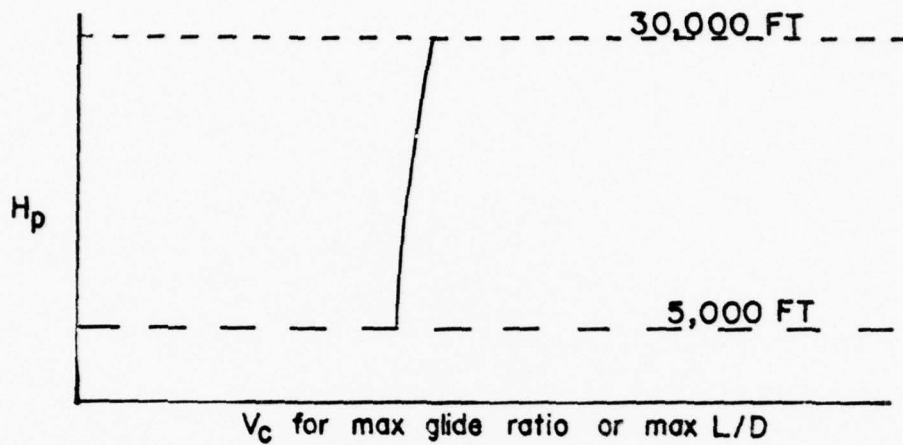

FIG. 3B-8

Note: the exact shape of this curve will depend upon (1) compressibility corrections, (2) effects of R_N on C_L and C_D curves, (3) effects of M on C_L and C_D curves and (4) the variation of test gross weights. Usually the difference in V_c is not great enough to warrant the publishing a "schedule" to the fleet -- a picked V_c will suffice.

Weight must be controlled throughout the test in some airplanes. If you know the gross weight at the points that define the curve above, the corrected V_c for a standard gross weight may be calculated by the formula:

$$\frac{W_{\text{Test}}}{v_{e \text{ Test}}^2} = \frac{W_{\text{Standard}}}{v_{e \text{ Standard}}^2} \quad (5)$$

(Notice that the V_c 's must be changed to V_e for the correction). The formula is based on the assumption of constant C_L for both conditions. Recommended schedules which apply for gross weights other than "standard" can be computed by the same formula.

What we have actually established in this test is the point marked L/D max as shown in figure 3B-9.

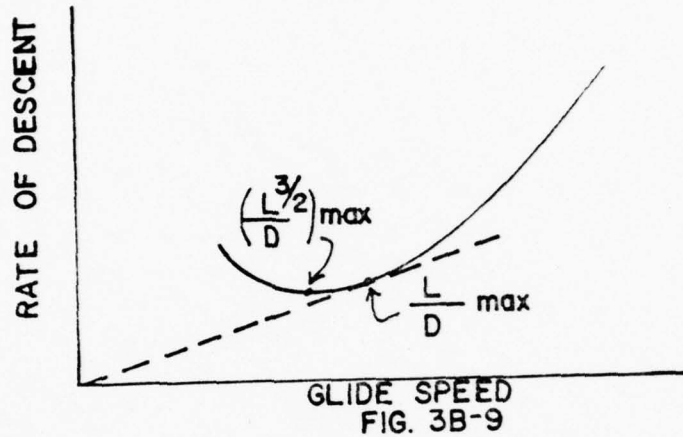

The $(L/D)_{MAX}$ may be found graphically by drawing a line from the origin to the point of tangency with the curve. (Note analogy with previously discussed power required curves). The point of minimum sink rate can be shown to occur at $\frac{L^{3/2}}{D_{MAX}}$.

As an example of establishing a descent schedule for an aircraft, observe figures 3B-10, 3B-11, and 3B-12 which are actual descent data plotted for the T-38A aircraft. Observe the varying parameters (time, distance, fuel used and rate of descent) from varying calibrated airspeeds. From these curves the actual optimum descent airspeeds are obtained.

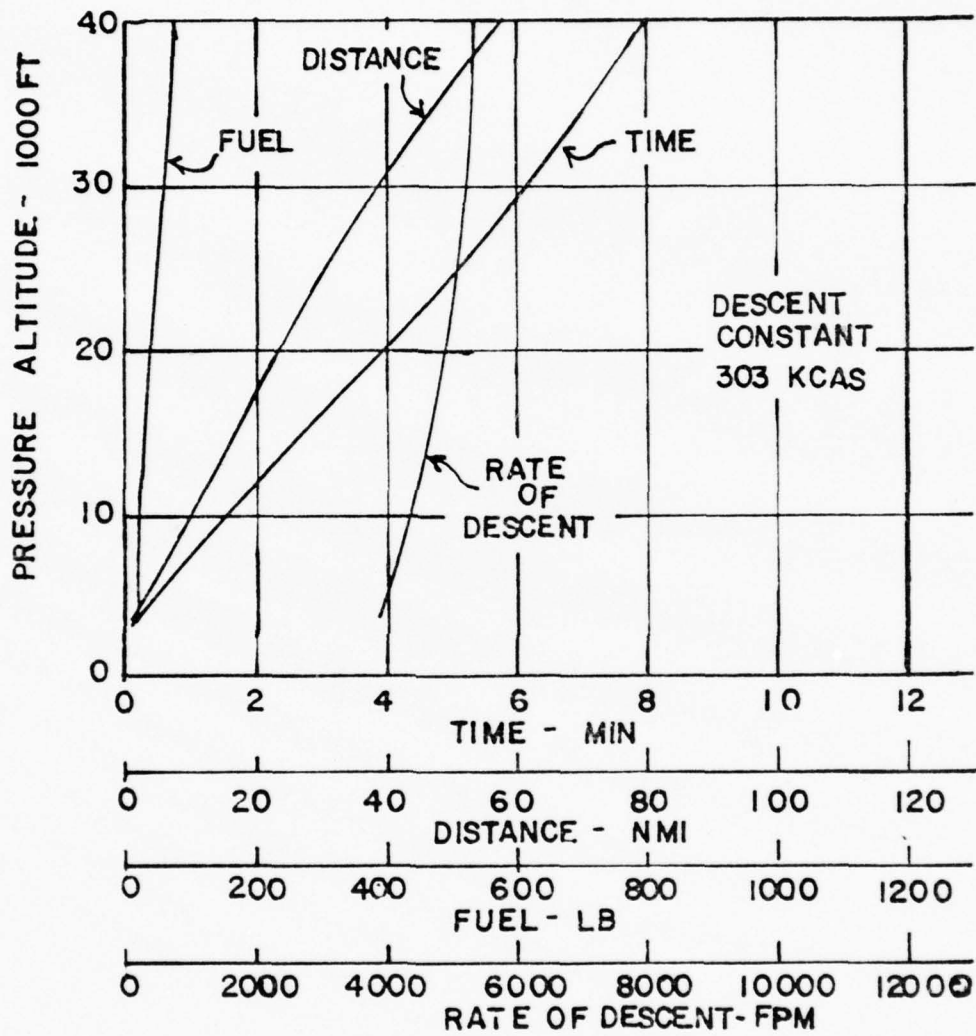

T-38A AIRCRAFT

FIG. 3B-10

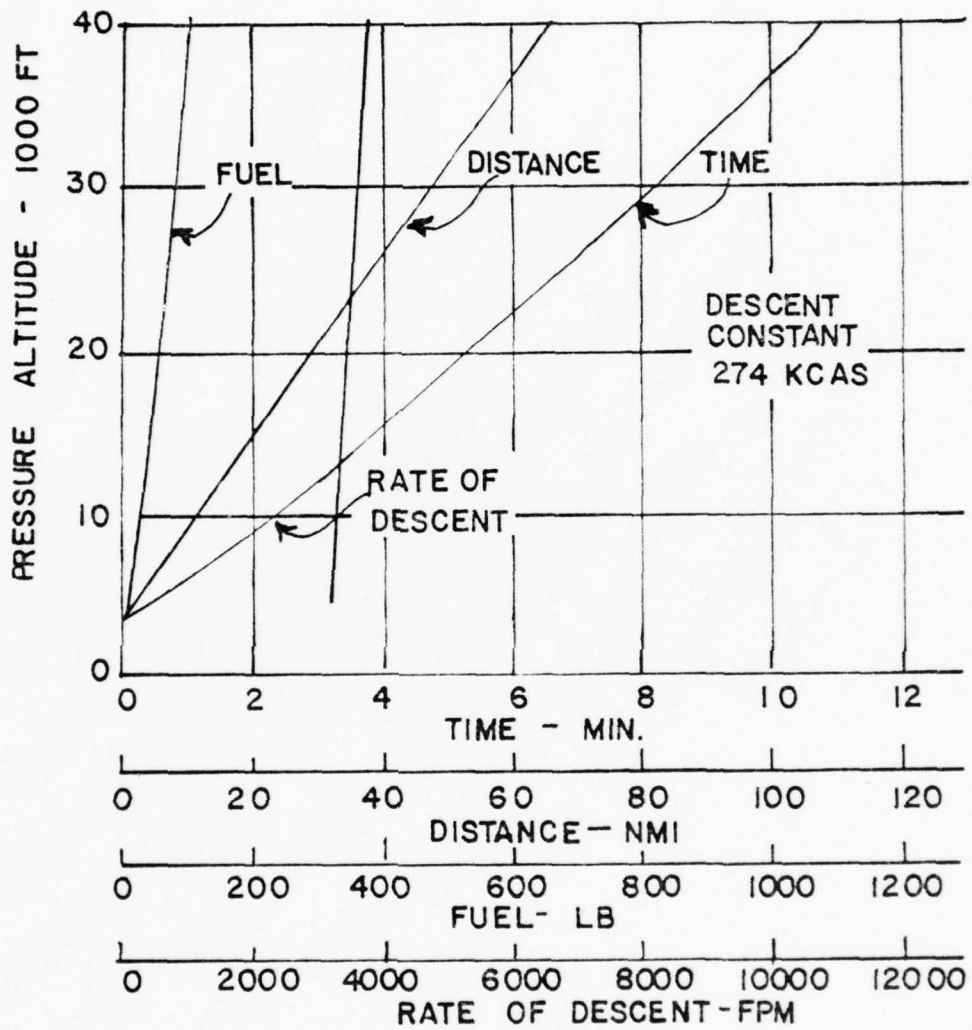

T-38A AIRCRAFT

FIG. 3B-II.

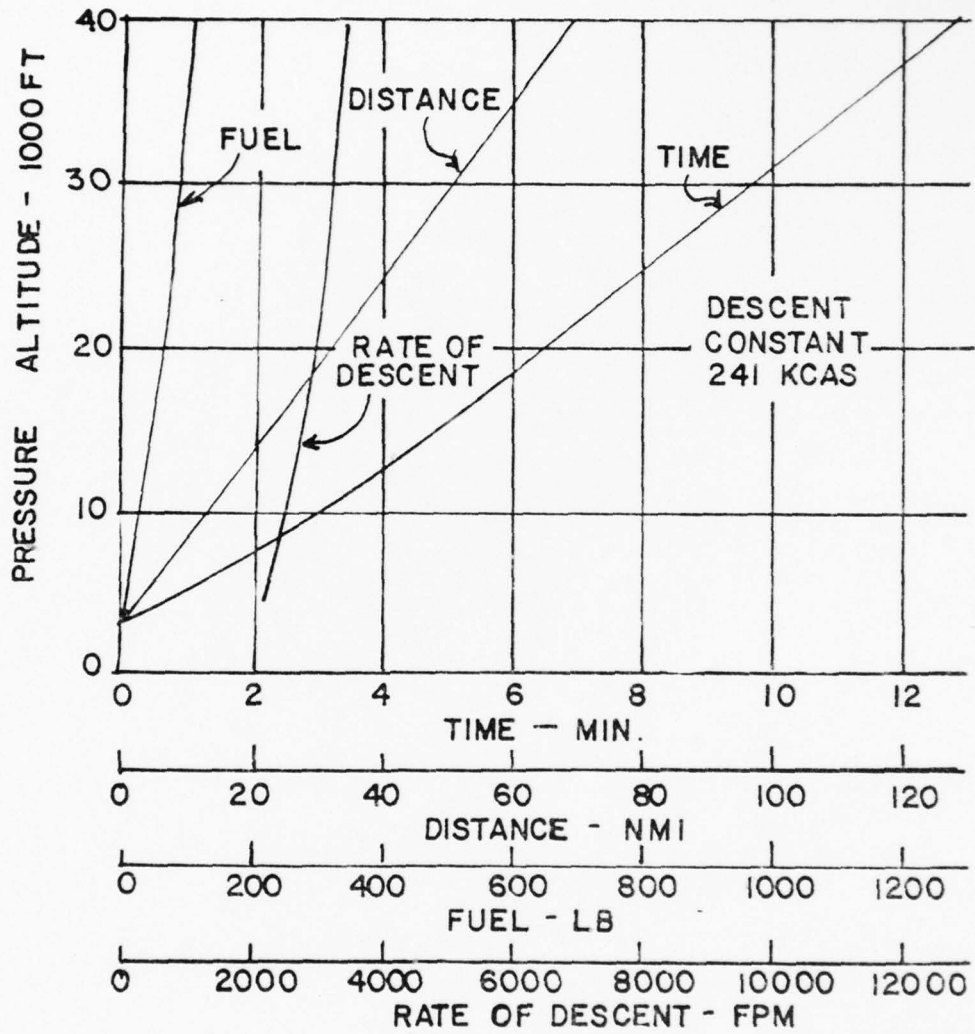

T-38A AIRCRAFT

FIG. 3B-12

3B-4, Final Stages of Descent Performance

In preparing for a landing we must stick out some high drag items such as wheels and flaps and in doing so we jump from one curve to another: See Figure 3B-13.

Once in the final stages of our approach in the landing configuration we must keep two things in mind: (1) we want to remain somewhere near the point of L/D max (landing configuration) and (2) we want to maintain sufficient speed for a good flare.

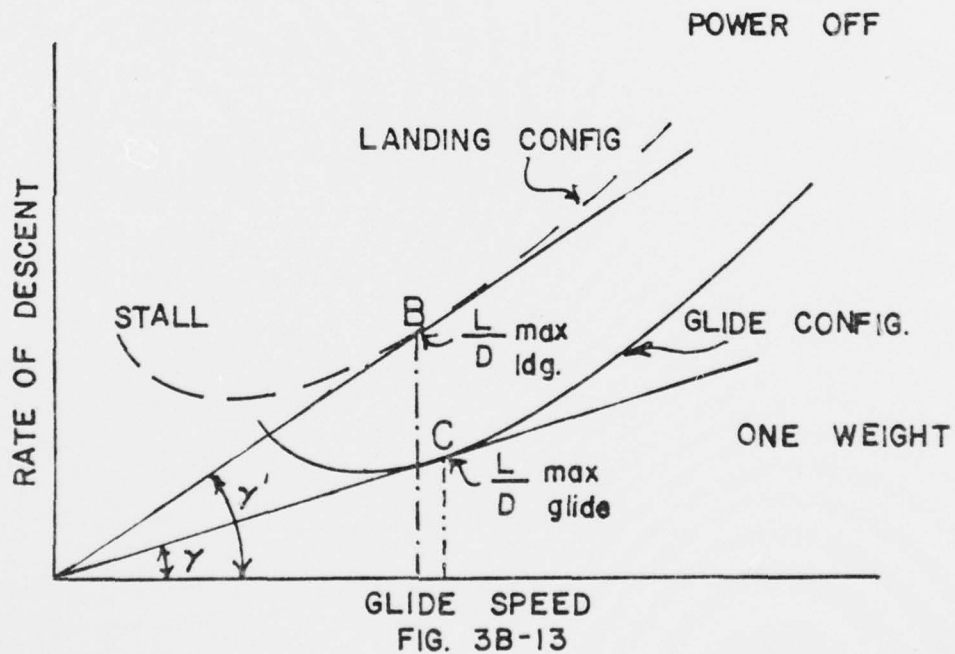

Once we leave our stabilized glide condition and start our flare, we leave the curve on the left (Figure 3B-13). By decelerating we trade our KE for PE and try to establish a flight path tangential to the runway. Once we stop decelerating, however, we are strapped to the rate of sink values listed

on the curve. You can only afford to decelerate to a speed as low as that necessary for control (see "stall" on 3B-13, so the control of speed and altitude at start of flare becomes a problem in pilot's judgement. The recommended landing configuration approach speeds for most present day jets has been in excess of the speed for L/D max (landing configuration). (Point B) (Notice that for the case shown by holding speed at B and cleaning up the airplane the glide can be "stretched" to Point C.) Remember, once the glide deceleration has stopped, the sink rate is fixed. To accelerate back up to start another flare you go from bad to worse (from an energy concept, the rate of sink is higher than the curve value).

Note should be taken of the fact that sink rates are high for airplanes of high wing loading and that there is an abrupt increase in sink rate below the stabilized speed for minimum sink as angle of attack is increased (increased induced drag). One current fighter plane has almost three times the sink rate at 125 knots that it has at 150 knots. (Both stabilized speeds in landing configuration.) If the pilot finds himself at low altitude at a speed below which he dares not decelerate, he is committed to landing like a streamlined safe.

SUPPLEMENTARY PROBLEMS

UNIT 3

1. A 10,000 lb aircraft at 10,000 feet has a coefficient of drag

$$C_D = 0.02 + 0.04 C_L^2$$

This aircraft has a wing area (S) of 600 ft² and a constant thrust of 6000 lb. What is the maximum rate of climb?

2. A reciprocating engine aircraft has a constant power available. At what velocity will this aircraft have the maximum rate of climb if the aircraft has a parabolic polar?
3. If the aircraft of Problem 1. loses its thrust, what is its maximum glide ratio?
4. An aircraft at 20,000 feet has a drag coefficient in the clean configuration of

$$C_D = 0.02 + 0.04 C_L^2$$

with the gear down, this aircraft has a drag coefficient of

$$C_D = 0.04 + 0.04 C_L^2$$

What is the difference in maximum gliding distance for the aircraft in the clean configuration as compared with the aircraft in the gear down configuration?

5. A T-1A jet aircraft weighing 15,000 lb burns 2,500 lb of fuel per hour at 300 knots at a geopotential altitude of 10,000 feet. If the airspeed is kept constant at 300 knots True air speed, what is the rate of climb of this aircraft due to weight change?

SUPPLEMENTARY PROBLEMS

SOLUTION SHEET

UNIT 3

1. Note, first of all, that from the drag coefficient equation one has the values for C_{D_0} (0.02) and $1/ARe$ (0.04). From Table 3, Appendix I at an altitude of 10,000 feet the density is $0.0017553 \text{ lb sec}^2/\text{ft}^4$.

From Eq. (17), 2-A,

$$D = 0.02 \times \frac{1}{2} \times 0.0017553 \times 600 \times V_T^2 + (0.04 \times 2 \times 10,000^2) / 0.0017553 \times 600 \times V_T^2$$

or

$$D = 1.053 \times 10^{-2} V_T^2 + 7.597 \times 10^6 V_T^{-2}$$

Rate of Climb is the excess power divided by the weight

$$RC = \frac{P_a - P_r}{W} = \frac{T \times V - D \times V}{W}$$

and the velocity for maximum rate of climb occurs where the change of Rate of Climb with velocity is equal to zero. (Take the derivative of RC with respect to V and equate to zero).

$$\frac{d RC}{d V} = T - \frac{d}{d V} (1.053 \times 10^{-2} V_T^3 + 7.597 \times 10^6 V_T^{-1})$$

or

$$6000 - (3 \times 1.053 \times 10^{-2} V_T^2 - 7.597 \times 10^6 V_T^{-2}) = 0$$

multiplying by $(-V_T^2)$ and clearing gives

$$V_T^4 - \frac{6000}{3 \times 1.053 \times 10^{-2}} V_T^2 - \frac{7.597 \times 10^6}{3 \times 1.053 \times 10^{-2}} = 0$$

This equation can be solved as a binomial equation in V_T^2 from which $V_T^2 = 1.912 \times 10^5 \text{ ft}^2/\text{sec}^2$ and

$$V_T = 437.25 \text{ ft/sec} = 259 \text{ kts}$$

Substituting the value for V_T in the Rate of Climb equation

$$RC = 1/10,000 \left\{ (6000 \times 437.25) - (1.053 \times 10^{-2} \cdot 437.25^3 + 7.597 \times 10^6 \cdot 437.25^{-1}) \right\}$$

$$RC = 172.59 \text{ ft/sec} = 10,355 \text{ ft/min}$$

2. If power available is a constant, the maximum excess power will occur when the power required is a minimum. This is at the velocity for which $C_{D_i} = 3 C_{D_0}$. Note the resemblance of this problem to Problem 1. If the power available is not a function of velocity (is a constant) the derivative of the

SUPPLEMENTARY PROBLEMS

SOLUTION SHEET

UNIT 3

(Cont)

2. (Continued)

power available with respect to velocity is zero. In Problem 1 this derivative was equal to the thrust. With Thrust a constant (Problem 1)

$$\frac{d RC}{d V} = T - (3 D_o + D_i)$$

and for a constant power available (this problem)

$$\frac{d RC}{d V} = - (3 D_o + D_i)$$

therefore,

$$(3 \times 1.053 \times 10^{-2} V_T^2 - 7.597 \times 10^6 V_T^{-1}) = 0$$

and

$$V_{T \text{ MAX RC}} = 193.9 \text{ ft/sec (If the drag is the same as in Problem 1).}$$

3. Maximum power-off glide occurs at the point of $(L/D)_{\text{MAX}}$ and the glide ratio is $(L/D)_{\text{MAX}}$. Since this is the point of minimum drag, maximum glide distance occurs where parasite drag equals induced drag. Since the parasite drag coefficient is 0.02, and the induced drag coefficient is $0.04 C_L^2$, at minimum drag

$$0.02 = 0.04 C_L^2$$

and

$$C_{L(L/D)_{\text{MAX}}} = 0.707$$

At this lift coefficient the ratio of C_L/C_D (the glide ratio, γ) is

$$\gamma = \frac{C_L}{C_D} = \frac{0.707}{0.02 + 0.02} = 17.68$$

(Note that $C_D =$ twice C_{D_o} and that C_{D_i} (0.04×0.707^2) equals C_{D_o} (0.02))

4. From Problem 3 above, the glide ratio is 17.68. This means that the aircraft at altitude will glide a distance 17.68 times its altitude, or

$$\text{Glide range} = 17.68 \times (20,000 \text{ ft}/6080 \text{ ft/nmi}) = 58.6 \text{ nmi}$$

SUPPLEMENTARY PROBLEMS

SOLUTION SHEET

UNIT 3

(Cont)

4. (Continued)

With the landing gear down the parasite drag coefficient has increased to 0.04. The lift coefficient at minimum drag is now

$$C_{L_{MAX \text{ Glide}}} = (0.04/0.04)^{\frac{1}{2}} = 1.0$$

and $(L/D)_{MAX}$ is $1.0/(2 \times 0.04) = 12.5$

The glide range with gear down is therefore:

$$\text{Glide range} = 12.5 \times (20,000\text{ft}/6080 \text{ ft/nmi}) = 41.1 \text{ nmi}$$

The difference in glide range is

$$58.6 - 41.1 = \underline{17.5 \text{ nmi.}}$$

5. For an aircraft at constant velocity with no change in thrust ($d TE/d t = 0$), the energy change equation (Eq. (7), 3A) is

$$\frac{d TE}{d t} = W \frac{d h}{d t} + h \frac{d W}{d T} + \frac{V^2}{2 g} \frac{d W}{d t} = 0$$

Solving for the Rate of Climb

$$RC = \frac{d h}{d t} = - \frac{1}{W} \left(h + \frac{V^2}{2 g} \right) \frac{d W}{d t}$$

from the problem

$$\frac{d W}{d t} = - 2,500 \text{ lb/hr} = - 0.70 \text{ lb/sec}$$

$$V = 300 \text{ kts} = 507 \text{ ft/sec}$$

therefore

$$RC = - \frac{1}{15,000} \left(10,000 + \frac{(507)^2}{2 \times 32.2} \right) \times (-.070)$$

$$RC = 0.65 \text{ ft/sec} = 39 \text{ ft/min}$$

To observe the long range effect of this constant velocity climb due to weight change, the problem may be solved in ten minute increments using a revised weight and altitude for each segment.

SUPPLEMENTARY PROBLEMS

SOLUTION SHEET

UNIT 3

(Cont)

5. (Continued)

Time min.	Altitude feet	Weight lbs	RC ft/min
t_0	10,000	15,000	39
$t_0 + 10$	10,390	14,583	41
$t_0 + 20$	10,804	14,166	44
$t_0 + 30$	11,242	13,749	47
$t_0 + 40$	11,707	13,332	49
$t_0 + 50$	12,201	12,915	53
$t_0 + 60$	12,745	12,498	54

With no change in thrust, and assuming that the fuel flow rate remains constant with this small change in altitude, the aircraft has climbed 2,745 feet in a hour due to the loss of fuel weight.

AE-2306

PERFORMANCE II

UNIT 4

Range, Cruise Climb, and Endurance

PERFORMANCE II

Unit 4 - Range, Cruise Climb, and Endurance

OBJECTIVES

As a result of your work in this Unit, you should be able to:

1. State the lift-to-drag relationships for maximum range for a turbojet and for a reciprocating engine aircraft.
2. Define Thrust Specific Fuel Consumption (TSFC).
3. Define Specific Range (SR).
4. Determine the maximum range for an aircraft at constant altitude, given the drag polar, initial and final weights and Brequet's Range Equation.
5. Determine the variation in Specific Range at constant altitude with a variation of aircraft weight.
6. Determine the variation in Specific Range at cruise climb with a variation of aircraft weight.
7. Define Specific Endurance.
8. Demonstrate, by use of thrust required versus velocity and power required versus velocity plots, the effect of altitude on maximum endurance for turbojet and reciprocating engines.
9. Explain why, for a jet aircraft, endurance increases up to some critical altitude, and then decreases.
10. Explain, with the use of thrust required versus velocity plot, the effect of headwind and tail wind on turbojet aircraft range.

AE 2306

PERFORMANCE II

Unit 4

PROCEDURE

1. Read Sections 4-A, 4-B and 4-C.
2. Review the Statement of Objectives.
3. Answer the Study Questions.
4. Review the resource material as necessary, based on your difficulty with the Study Questions.

When you are ready, ask for the written test on this Unit. This test will be Closed Book. Necessary equations will be furnished.

PERFORMANCE II

Unit 4

STUDY QUESTIONS

1. A jet and a recip aircraft have the same maximum range when their gross weights are 17,000 lbs including 4,000 lbs of useable fuel. Both aircraft have the capability of carrying an additional 6,000 lbs of fuel internally. Which aircraft has the greater increase in maximum range with the additional fuel?
2. A jet aircraft flying at maximum endurance loses power and enters a maximum distance power-off glide. What changes in Equivalent airspeed should the pilot make?
3. A recip aircraft flying at maximum endurance loses power and enters a maximum distance power-off glide. What changes in Equivalent air speed should the pilot make?
4. If an aircraft is climbing at a constant Mach number in the Troposphere, its Equivalent air speed is (increasing), (constant) or (decreasing).
5. If an aircraft is climbing at a constant Mach number in the Stratosphere, its Equivalent air speed is (increasing), (constant) or (decreasing).
6. What is the relationship between thrust required at altitude and the thrust required at sea level for a jet aircraft at maximum endurance if fuel flow is a function only of thrust? What is the relationship of the velocities?
7. What is meant by "critical" altitude for a jet aircraft?
8. On a plot of thrust required versus velocity, show the points of maximum endurance and maximum constant altitude range for a jet aircraft.
9. On a plot of power required versus velocity, show the points of maximum endurance and maximum constant altitude range for a recip aircraft. Draw comparisons between the information in Questions 8 and 9.
10. What is the relationship between parasite drag and induced drag at the velocity for maximum range for a jet?

PERFORMANCE II

Unit 4

STUDY QUESTIONS - SOLUTIONS

$$1. R_j = f(\sqrt{W_o} - \sqrt{W_1}) \qquad R_p = f\left(\ln \frac{W_o}{W_1}\right)$$

for $W_o = 17,000$ lbs and $W_1 = 13,000$ lbs (4,000 lb fuel)

$$(\sqrt{17,000} - \sqrt{13,000}) = 16.36 ; \ln \frac{17,000}{13,000} = 0.2682$$

If both aircraft have the same range, the relationship between the two weight functions must be 60.984

$$0.2682 \times 60.984 = 16.36$$

for $W_o = 23,000$ and $W_1 = 13,000$ (adding 6,000 lb fuel)

$$(\sqrt{17,000} - \sqrt{13,000}) = 37.639 ; \ln \frac{23,000}{13,000} = 0.571$$

$$0.571 \times 60.984 = 34.794$$

Jet has most increase in range

2. Max Endurance for a Jet is at $T = D_{min}$
 Max Power-off Glide is at D_{min}
 T Therefore, glide at the same velocity

3. Max Endurance for Prop is at P_{min}
 Max Power-off Glide Distance is still at D_{min} .

$$V_{min Pwr} < V_{min Drag}$$

Therefore, Speed up!

$$4. q = \frac{1}{2} \gamma p_a M^2 = \frac{1}{2} \rho_{ssl} V_e^2$$

If M is a constant and p_a decreasing (climbing).
 q is decreasing. If q is decreasing, V_e is also decreasing.

5. Same answer as Question 4.

6.

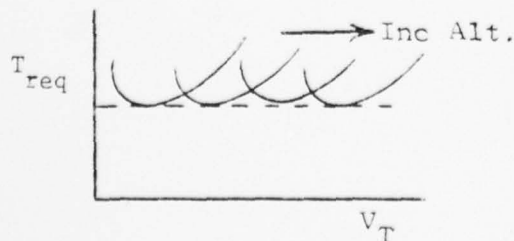

$T_{req} = \text{same}$
 $V_e = \text{same}$
 $V_T = \text{increases with alt}$

STUDY QUESTIONS - SOLUTIONS (Continued)

7. Altitude where Specific Range begins decreasing with increasing altitude.

8.

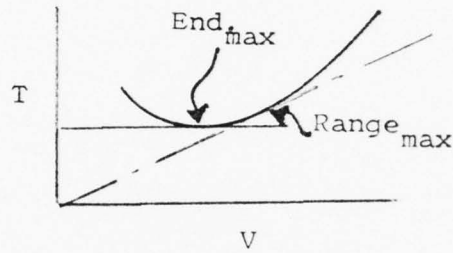

9.

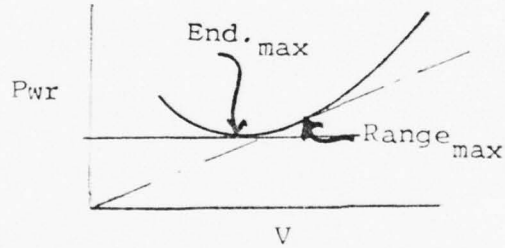

10. At max Range (Jet), $3C_{D_o} = C_{D_i}$

Unit 4-A

Range Performance

4A-1. INTRODUCTION

The ability of an airplane to convert fuel energy into flying distance is one of the most important items of airplane performance. The problem of efficient range operation of an airplane appears of two general forms in flying operations: (1) to extract the maximum flying distance from a given fuel load or (2) to fly a specified distance with minimum expenditure of fuel. An obvious common denominator for each of these operating problems is the "specific range," nautical miles of flying distance per lb. of fuel. Cruise flight for maximum range conditions should be conducted so that the airplane obtains maximum specific range throughout the flight.

The principal items of range performance can be visualized by use of the illustrations of figure 4A-1. From the characteristics of the aerodynamic configuration and the powerplant, the conditions of steady level flight will define various rates of fuel flow throughout the range of flight speed. The graph of figure 4A-1 illustrates a typical variation of fuel flow versus velocity.

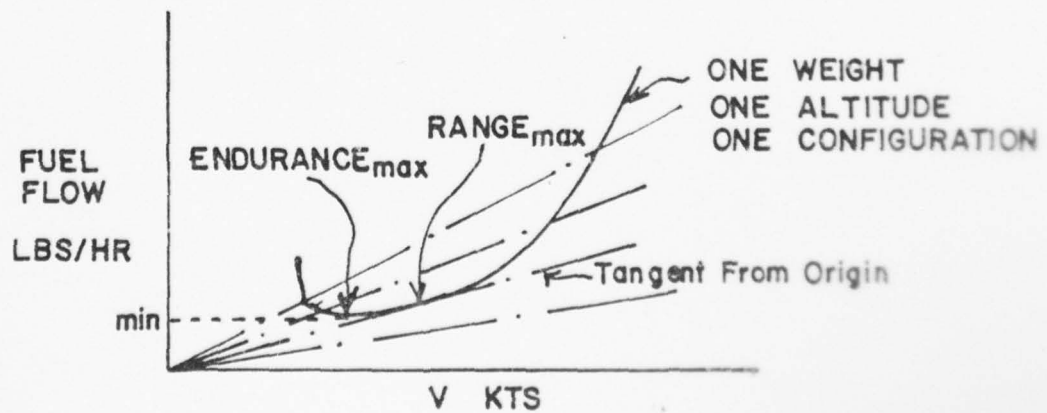

FIG. 4A-1

AD-A039 654

NAVAL POSTGRADUATE SCHOOL MONTEREY CALIF
A PERSONALIZED SYSTEM OF INSTRUCTION FOR AIRCRAFT PERFORMANCE.(U)
MAR 77 D L FINCH

F/G 5/9

UNCLASSIFIED

NL

3 of 5
ADA
039654



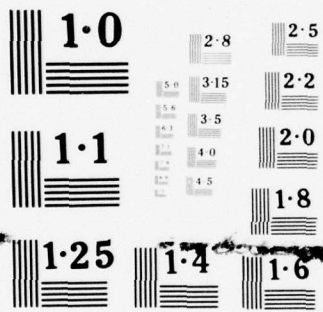

NATIONAL BUREAU OF STANDARDS
MICROCOPY RESOLUTION TEST CHART

4A-2. TURBOJET RANGE

In the consideration of the theoretical aspects of optimizing range of an airplane, there are airframe desires, engine desires and pilot desires. In-as-much as range is measured "over the ground" and not through the air mass, there is also a wind effect on range.

The airframe prefers to operate at the point of minimum drag (or maximum L/D) for best range. This is the most "efficient" angle of attack for the airframe from a range standpoint. For subsonic flight, the value of minimum drag does not appreciably vary with altitude but the true airspeed at which it occurs does increase with an increase in altitude (or decrease in density). This would indicate a preference on the part of the airframe for higher altitudes since a higher true airspeed can be attained for the same expenditure of thrust.

The turbo-jet engine operates best at high thermal efficiencies, with thermal efficiency being a function of the power output divided by the heat energy input

$$\eta_T = \frac{\text{Power Output}}{(\text{Fuel Flow Rate})(\text{Heating Value/lb fuel})}$$

or

$$\eta_T = \frac{k \times T_r \times V_T}{W_f \times \text{H.V.}} \quad (1)$$

Thrust Specific Fuel Consumption (TSFC) is defined as Fuel Flow Rate (Lbs per hour) divided by the Thrust Required (lbs), or $\text{TSFC} = W_f/T_r$, and Specific Range is defined as Velocity divided by Fuel Flow Rate

$$SR = \frac{V_T \text{ Miles (per hour)}}{W_f \text{ lb Fuel (per hour)}} \quad (2)$$

so that equation (1) may be rewritten as

$$\eta_T = \frac{k \times V_T}{TSFC \times H.V.} \quad \text{or} \quad = k \times SR \times \frac{T_r}{HV} \quad (3)$$

From equation (3) it is seen that for maximum thermal efficiency, true airspeed should be maximized and Thrust Specific Fuel Consumption should be minimized. The inherent relationship between thermal efficiency and range may be seen in equation (3).

The TSFC does not vary appreciably over cruise speed ranges at a particular altitude, and minimum fuel flow occurs fairly close to maximum L/D (minimum thrust required). TSFC decreases with an increase in altitude.

Range considerations include both the distance covered and the low fuel flow, and so specific range has been defined as the miles of range that can be covered per pound of fuel consumed (Equation (2)). If minimum fuel flow occurs at minimum thrust required $(C_L/C_D)_{\max}$. This is usually the case. It should be recalled from previous sections of the course that the true airspeed at which $(C_L/C_D)_{\max}$ occurs on drag curves increases with an increase in altitude. This gives an indication that high altitudes (up to some critical altitude) may be better for increased specific range.

The exact factors affecting range may be determined from the relationship between range, velocity and time, where the range is the integral of the velocity with time.

$$R = \int V dt \quad (4)$$

since

$$W_f = - \frac{dW}{dt} = \text{TSFC} \times T_r \quad (5)$$

Equation (4) may be re-written with new limits on the integral as

$$R = \int_{W_1}^{W_0} \frac{V_T}{\text{TSFC} \times T_r} dW \quad (6)$$

Since Thrust Required equal Drag for level flight

$$T_r = \frac{1}{2} \rho V^2 S C_D = W \frac{C_D}{C_L} \quad (7)$$

also

$$V_T = \sqrt{\frac{2W}{C_L S}} \quad (8)$$

substituting (7) and (8) into (6)

$$R = \int_{W_0}^{W_1} \frac{\sqrt{2}}{(\text{TSFC}) \sqrt{\rho S} \frac{C_L^{\frac{1}{2}}}{C_D} \frac{dW}{W^{\frac{1}{2}}}} \quad (9)$$

Integration of Equation (9) gives (with conversion of units)

$$R_{\text{nmf}} = \frac{1.675}{(\text{TSFC}) \sqrt{\rho S}} \frac{C_L}{C_D} (\sqrt{W_0} - \sqrt{W_1}) \quad (10)$$

Equation (10) is known as Breguet's Range Equation for jet aircraft.

From Equation (1) it may be observed that the maximum range for a given fuel load is a function of maximum $(C_L^{\frac{1}{2}}/C_D)$, maximum altitude $(1/\rho)$ and minimum TSFC (which also occurs at altitude).

It may be proven mathematically that the point of $(C_L^{\frac{1}{2}}/C_D)$ lies on the drag (or thrust required) versus velocity curve at the point of tangency of

a line from the origin, as shown in figure 4A-2. This point is always at a greater velocity than the minimum drag point $(C_L/C_D)_{max}$.

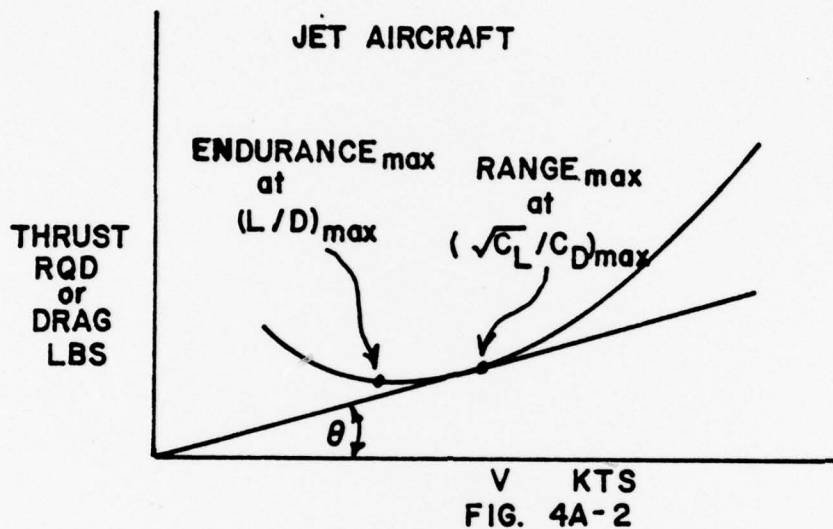

At this time it may be necessary to recall that the foregoing theoretical considerations are just that - theoretical. They are essential in the estimation of performance figures, but if an airplane is available there is no substitute for measuring actual range characteristics. The only type of plot which will give actual altitudes for best specific range and actual speeds for best range at an altitude is a plot based on flight test data which has generalized and properly reduced.

A plot of fuel flow versus true airspeed for a particular standard altitude will show actual specific range characteristics. On this plot the cotangent of the angle formed by a ray from the origin which intersects the curve will equal the specific range at the points of intersection. The point at which this ray is just tangent will be the point of maximum specific range. See figure 4A-3. Specific range will be discussed in more detail in

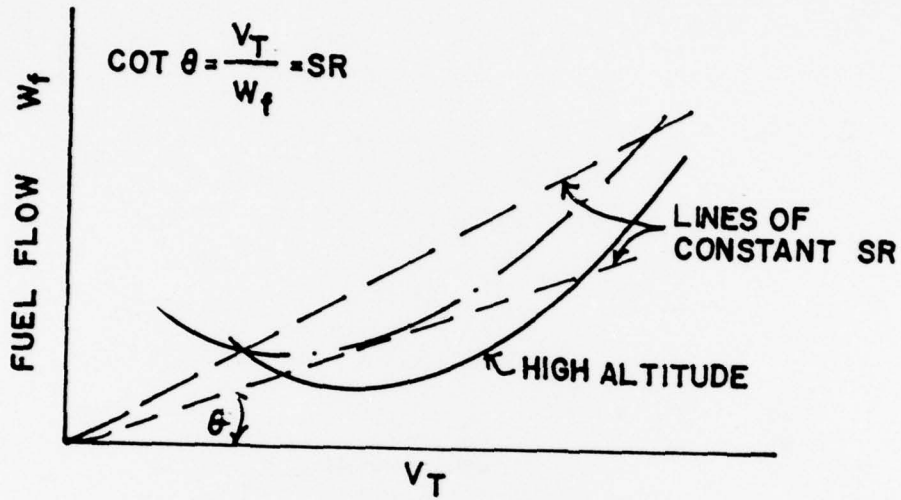

FIG. 4A-3

The effect of the variation of airplane gross weight is illustrated by figure 4A-4. The flight condition of $(C_L/C_D)_{\text{max}}$ is achieved at one value of lift coefficient for a given airplane in subsonic flight. Hence, a variation of gross weight will alter the values of airspeed, thrust required and specific range obtained at $(C_L/C_D)_{\text{max}}$.

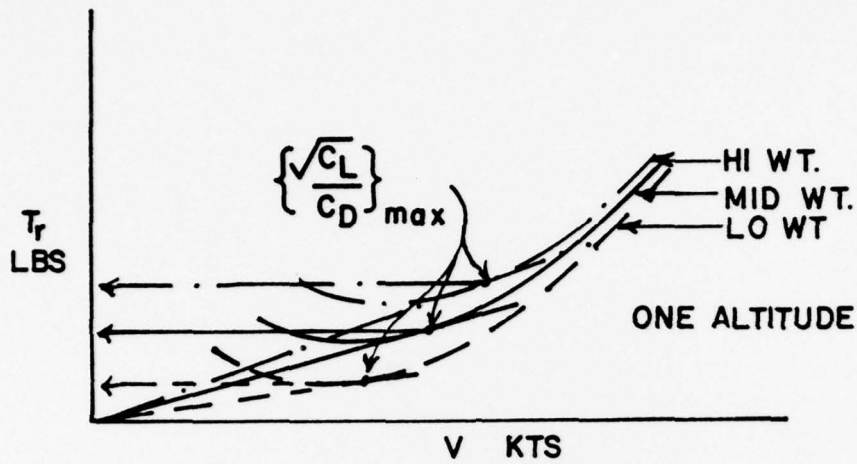

FIG. 4A-4

If a given configuration is operated at constant altitude and lift coefficient the following relationships will apply:

$$\frac{V_2}{V_1} = \sqrt{\frac{W_2}{W_1}}$$

$$\frac{Tr_2}{Tr_1} = \frac{W_2}{W_1}$$

$$\frac{SR_2}{SR_1} = \sqrt{\frac{W_1}{W_2}} \text{ (constant altitude)}$$

where

condition (1) applies to some known condition of velocity, thrust required, and specific range for $\left(\frac{\sqrt{C_L}}{C_D} \right)_{\max}$ at some basic weight, W_1

condition (2) applies to some new values of velocity, thrust required, and specific range for $\left(\frac{\sqrt{C_L}}{C_D} \right)_{\max}$ at some different weight, W_2

and

V = velocity, knots

W = gross weight, lbs.

Tr = thrust required, lbs.

SR = specific range, nmi/lb.

Thus, a 10 percent increase in gross weight would create:

a 5 percent increase in velocity

a 10 percent increase in thrust required

a 5 percent decrease in specific range

when flight is maintained at the optimum conditions of $(\sqrt{C_L/C_D})_{\max}$.

Since most jet airplanes have a fuel weight which is a large part of the gross weight, cruise control procedures will be necessary to account for the changes in optimum airspeeds and power settings as fuel is consumed.

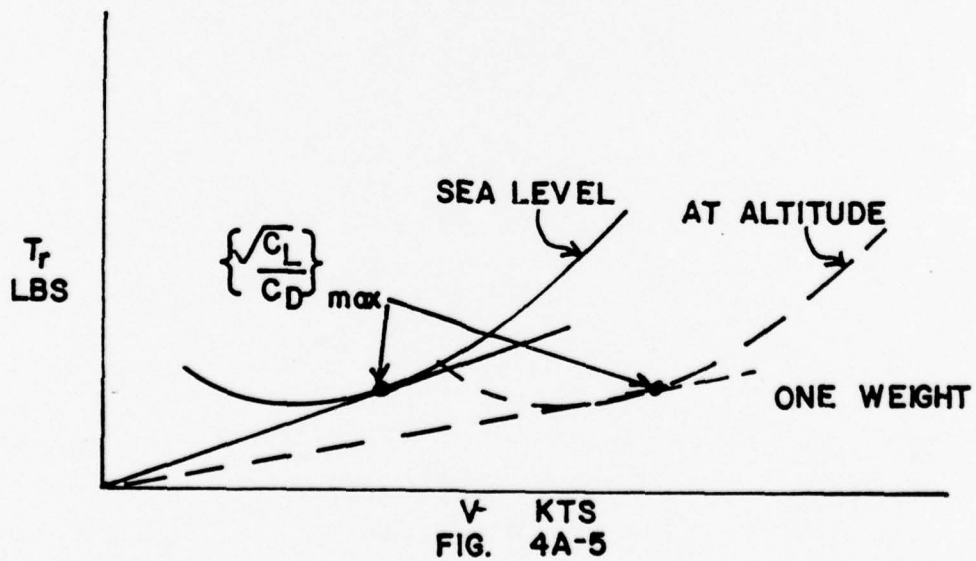

The effect of altitude on the range of the turbojet airplane is of great importance because no other single item can cause such large variations of specific range. See figure 4A-5. If a given configuration of airplane is operated at constant gross weight and the lift coefficient for $(C_L/C_D)_{\max}$, a change in altitude will produce the following relationships:

$$\frac{V_2}{V_1} = \frac{\sqrt{\sigma_1}}{\sqrt{\sigma_2}}$$

Tr = constant (neglecting compressibility effects)

$$\frac{SR_2}{SR_1} = \frac{\sqrt{\sigma_1}}{\sqrt{\sigma_2}} \text{ (neglecting factors affecting engine performance)}$$

where

condition (1) applies some known condition of velocity, thrust required, and specific range for $(C_L/C_D)_{\max}$ at some original, basic altitude.

condition (2) applies to some new values of velocity, thrust required, and specific range for $(C_L/C_D)_{\max}$ at some different altitude.

and

V = velocity, knots (TAS, of course)

Tr = thrust, required, lbs.

SR = specific range, nmi/lb.

σ = altitude density ratio (sigma)

Thus, if flight is conducted at 40,000 ft. ($\sigma = 0.246$), the airplane will have:

- a 102 percent higher velocity
- the same thrust required
- a 102 percent higher specific range

(even when the beneficial effects of altitude on engine performance are neglected)

than when operating at sea level. Of course, the greater velocity is a higher TAS and the same thrust required must be obtained with a greater engine RPM.

At this point it is necessary to consider the effect of the operating condition on powerplant performance. An increase in altitude will improve powerplant performance in two respects. First, an increase in altitude when below the tropopause will provide lower inlet air temperatures which reduce the specific fuel consumption. Of course, above the tropopause the specific fuel consumption tends to increase. At low altitude, the engine RPM necessary to produce the required thrust is low and, generally, well below the normal rated value. Thus, a second benefit of altitude on engine performance is due to the increased RPM required to furnish cruise thrust. An increase in engine speed to the normal rated value will reduce the specific fuel consumption.

The increase in specific range with altitude of the turbojet airplane can be attributed to these three factors:

(1), An increase in altitude will increase the proportion of (V/Tr) and provide a greater TAS for the same Tr .

(2) An increase in altitude in the troposphere will produce lower inlet air temperature which reduces the specific fuel consumption.

(3) An increase in altitude requires increased engine RPM to provide cruise thrust and the specific fuel consumption reduces as normal rated RPM is approached.

The combined effect of these three factors defines altitude as the one most important item affecting the specific range of the turbojet airplane. As an example of this combined effect, the typical turbojet airplane obtains a specific range at 40,000 ft. which is approximately 150 percent greater than that obtained at sea level. The increased TAS accounts for approximately two-thirds of this benefit while increased engine performance accounts for the other one-third of the benefit. For example, at sea level the maximum specific range of a turbojet airplane may be 0.1 nmi/lb. but at 40,000 ft. the maximum range would be approximately 0.25 nmi/lb.

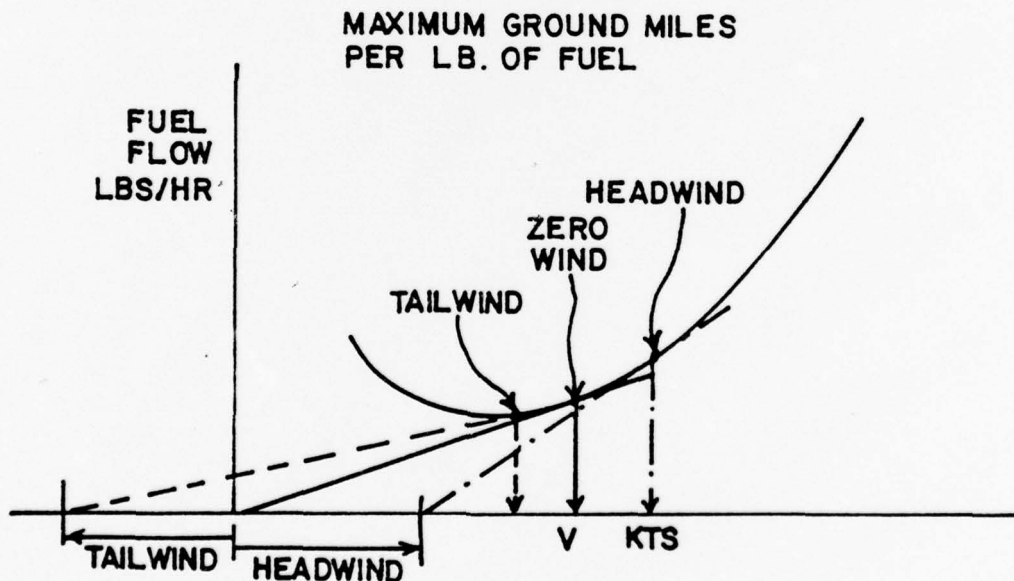

FIG. 4A-6

The effect of wind on range is of considerable importance in flying operations. Of course, a headwind will always reduce range and a tailwind will always increase range. The selection of a cruise altitude with the most favorable (or least unfavorable) winds is a relatively simple matter for the case of the propeller powered airplane. Since, as will be shown later, the range of the propeller powered airplane is relatively unaffected by altitude, the altitude with the most favorable winds is selected for range. However, the range of the turbojet airplane is greatly affected by altitude so the selection of an optimum altitude will involve considering the wind profile with the variation of range with altitude. Since the turbojet range increases greatly with altitude, the turbojet cannot tolerate less favorable (or more unfavorable) winds with increased altitude.

In some cases, large values of wind may cause a significant change in cruise velocity to maintain maximum ground nautical miles per lb. of fuel. As an example of an extreme condition, consider an airplane flying into a headwind which equals the cruise velocity. In this case, any increase in velocity would improve range.

To appreciate the changes in optimum speeds with various winds, refer to the illustration of figure 4A-6. When zero wind conditions exist, a straight line from the origin tangent to the curve of fuel flow versus velocity will locate maximum range conditions. When a headwind condition exists, the speed for maximum ground range is located by a line tangent drawn from a velocity offset equal to the headwind velocity. This will locate maximum range at some higher velocity and fuel flow. Of course, the range will be less than when at zero wind conditions but the higher velocity

and fuel flow will minimize the range loss due to the headwind. In a similar sense, a tailwind will reduce the cruise velocity to maximize the benefit of the tailwind.

4A-3. PROPELLER AIRCRAFT RANGE.

The propeller driven airplane combines the propeller with the reciprocating engine or the gas turbine for propulsive power. In the case of either the reciprocating engine or the gas turbine combination, powerplant fuel flow is determined mainly by the shaft power put into the propeller rather than thrust. Thus, the powerplant fuel flow could be related directly to power required to maintain the airplane in steady, level flight. This fact allows study of the range of the propeller powered airplane by analysis of the curves of power required versus velocity.

In a manner similar to that for Breguet's Range Equation for a jet aircraft, it may be shown that the Range in nautical miles for a propeller aircraft is

$$R_{\text{nmi}} = 326 \frac{\eta_p}{c} \frac{C_L}{C_D} \log_e \frac{W_0}{W_1} \quad (11)$$

where

η_p = the propeller efficiency

c = specific fuel consumption, lb/BHP-hr

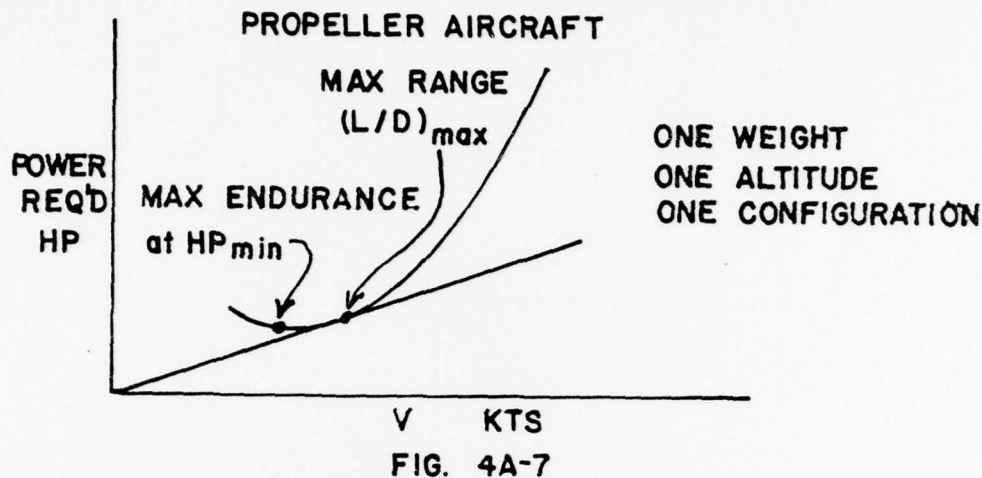
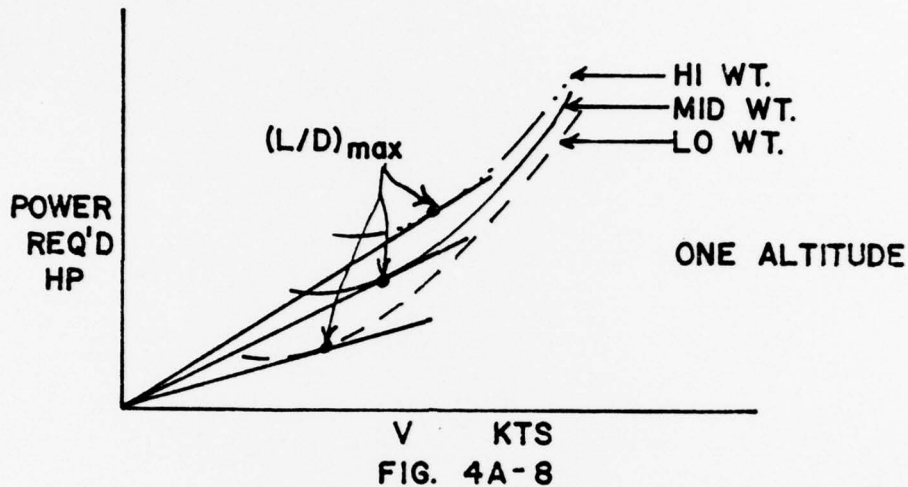

Figure 4A-7 illustrates a typical curve of power required versus velocity which, for the propeller powered airplane, would be analogous to the variation of fuel flow versus velocity. Maximum endurance condition would be obtained at the point of minimum power required since this would require the lowest fuel flow to keep the airplane in steady, level flight. Maximum range condition would occur where the proportion between velocity and power required is greatest and this point is located by a straight line from the origin tangent to the curve.

The maximum range condition is obtained at maximum lift-drag ratio and it is important to note that $(L/D)_{max}$ for a given airplane configuration occurs at a particular angle of attack and lift coefficient and is unaffected by weight or altitude (within compressibility limits). Since approximately 50 percent of the total drag at $(L/D)_{max}$ is induced drag, the propeller

powered airplane which is designed specifically for long range will have a strong preference for the high aspect ratio planform.



The effect of the variation of airplane gross weight is illustrated by figure 4A-8. The flight condition of $(L/D)_{\max}$ is achieved at one particular value of lift coefficient for a given airplane configuration. Hence, a variation of gross weight will alter the values of airspeed, power required, and specific range obtained at $(L/D)_{\max}$. If a given configuration of airplane is operated at constant altitude and the lift coefficient for $(L/D)_{\max}$, the following relationships will apply:

$$\frac{V_2}{V_1} = \sqrt{\frac{W_2}{W_1}}$$

$$\frac{Pr_2}{Pr_1} = \left(\frac{W_2}{W_1}\right)^{3/2}$$

$$\frac{SR_2}{SR_1} = \frac{W_1}{W_2}$$

where

condition (1) applies to some known condition of velocity, power required, and specific range for $(L/D)_{\max}$ at some basic weight, W_1 .

condition (2) applies to some new values of velocity, power required, and specific range for $(L/D)_{\max}$ at some different weight, W_2

and,

V = velocity, knots

W = gross weight, lbs.

Pr = power required, h.p.

SR = specific range, nmi/lb.

Thus a 10 percent increase in gross weight would create:

a 5 percent increase in velocity

a 15 percent increase in power required

a 9 percent decrease in specific range

when flight is maintained at the optimum conditions of $(L/D)_{\max}$. The variations of velocity and power required must be monitored by the pilot as part of the cruise control to maintain $(L/D)_{\max}$. When the airplane fuel weight is a small part of the gross weight and the range is small, the cruise control procedure can be simplified to essentially a constant speed and power setting throughout cruise. However, the long range airplane has a fuel weight which is a considerable part of the gross weight and cruise control procedure must employ scheduled airspeed and power changes to maintain optimum range conditions.

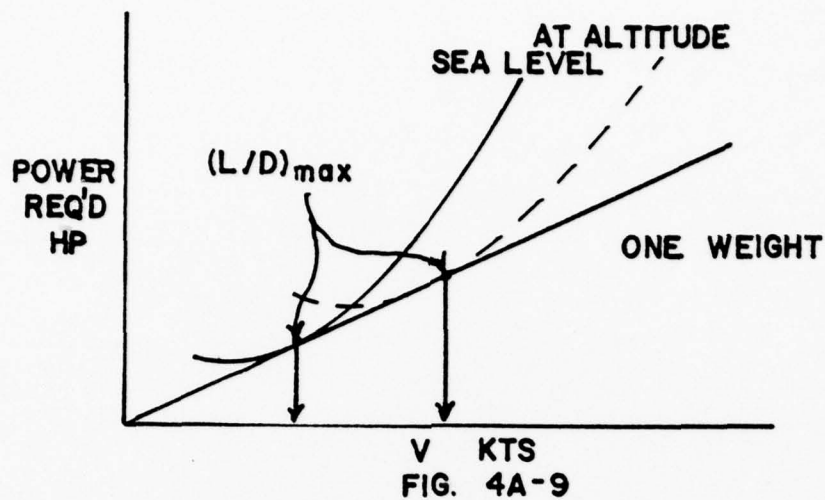

The effect of altitude on the range of the propeller powered airplane may be appreciated by inspection of figure 4A-9. If a given configuration of airplane is operated at constant gross weight and the lift coefficient for $(L/D)_{\max}$, a change in altitude will produce the following relationships:

$$\frac{V_2}{V_1} = \sqrt{\frac{\sigma_1}{\sigma_2}}$$

$$\frac{P_{r_2}}{P_{r_1}} = \sqrt{\frac{\sigma_1}{\sigma_2}}$$

where

condition (1) applies to some known condition of velocity and power required for $(L/D)_{\max}$ at some original, basic altitude

condition (2) applies to some new values of velocity and power required for $(L/D)_{\max}$ at some different altitude

and

V = velocity, knots (TAS, of course)

P_r = power required, h.p.

σ = altitude density ratio (sigma)

Thus, if flight is conducted at 22,000 ft. ($\sigma = 0.498$), the airplane will have:

a 42 percent higher velocity

a 42 percent higher power required

than when operating at sea level. Of course, the greater velocity is a higher TAS since the airplane at a given weight and lift coefficient will require the same EAS independent of altitude. Also, the drag of the airplane at altitude is the same as the drag at sea level but the higher TAS causes a proportionately greater power required. Note that the same straight line from the origin tangent to the sea level power curve also is tangent to the altitude power curve.

The effect of altitude on specific range can be appreciated from the previous relationships. If a change in altitude causes identical changes in velocity and power required, the proportion of velocity to power required would be unchanged. This fact implies that the specific range of the propeller powered airplane would be unaffected by altitude. In the actual case, this is true to the extent that powerplant specific fuel consumption and propeller efficiency (η_p) are the principal factors which could cause a variation of specific range with altitude. If compressibility effects are negligible, any variation of specific range with altitude is strictly a function of engine-propeller performance.

The airplane equipped with the reciprocating engine will experience very little, if any, variation of specific range with altitude at low altitudes. There is negligible variation of brake specific fuel consumption for values of BHP below the maximum cruise power rating of the powerplant which is the auto-lean or manual lean range of engine operation. Thus, an increase in altitude will produce a decrease in specific range only when the increased power requirement exceeds the maximum cruise power rating of the powerplants. One advantage of supercharging is that the cruise power may be maintained at high altitude and the airplane may achieve the range at high altitude with the corresponding increase in TAS. The principal differences in the high altitude cruise and low altitude cruise are the true airspeeds and climb fuel requirements.

The airplane equipped with the turboprop powerplant will exhibit a variation of specific range with altitude for two reasons. First, the specific fuel consumption of the turbine engine improves with the lower inlet temperatures common to high altitudes. Also, the low power requirements to achieve optimum aerodynamic conditions at low altitude necessitate engine operation at low, inefficient output power. The increased power requirements at high altitudes allow the turbine powerplant to operate in an efficient output range. Thus, while the airplane has no particular preference for altitude, the powerplants prefer the higher altitudes and cause an increase in specific range with altitude. Generally, the upper limit of altitude for efficient cruise operation is defined by airplane gross weight (and power required) or compressibility effects.

The optimum climb and descent for the propeller powered airplane is affected by many different factors and no general, all-inclusive relationship is applicable. Handbook data for the specific airplane and various operational factors will define operating procedures.

4A-4. SPECIFIC RANGE

The specific range can be defined by the following relationship:

$$\text{specific range} = \frac{\text{nautical miles}}{\text{lbs. of fuel}}$$

or,

$$\text{specific range} = \frac{\text{nautical miles/hr.}}{\text{lbs. of fuel/hr.}}$$

thus,

$$\text{specific range} = \frac{\text{velocity (knots)}}{\text{fuel flow (lbs. per hr)}}$$

If maximum specific range is desired, the flight condition must provide a maximum of velocity/fuel flow. This particular point would be located by drawing a straight line from the origin tangent to the curve of fuel flow versus velocity.

An analysis of range may be obtained by a plot of specific range versus velocity similar to 4A-10.

Of course, the source of these values of specific range is derived by the proportion of velocity and fuel flow from the previous curve of fuel flow versus velocity. The maximum specific range of the airplane is at the very peak of the curve. Maximum endurance point is located by a straight line from the origin tangent to the curve of specific range versus velocity. This tangency point defines a maximum of (nmi/lb) per (nmi/hr.) or simply a maximum of (hrs./lb.).

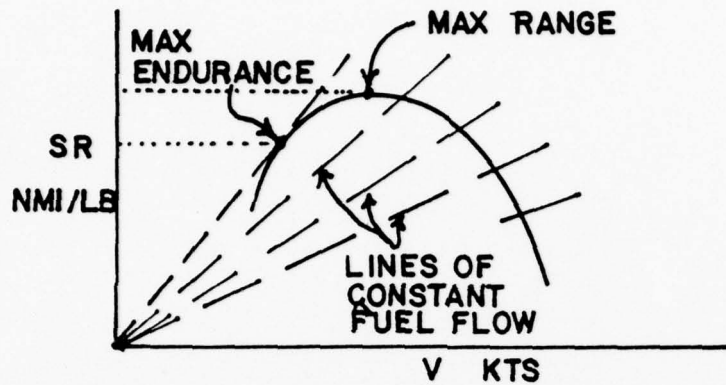

FIG. 4A-10

While the very peak value of specific range would provide maximum range operation, long range cruise operation is generally recommended at some slightly higher airspeed. The small sacrifice of range is a fair bargain. The curves of specific range versus velocity are affected by three principal variables: airplane gross weight, altitude, and the external aerodynamic configuration of the airplane. These curves are the source of range and endurance operating data and are included in the performance section of the flight handbook.

Figure 4A-11 shows a typical variation of specific range with gross weight for some particular cruise operation. At the beginning of cruise the gross weight is high and the specific range is low. As fuel is consumed, and the gross weight reduces, the specific range increases. This type of curve relates the range obtained by the expenditure of fuel by the crosshatched area between the gross weights at beginning and end of cruise. For example,

if the airplane begins cruise at 18,500 lbs. and ends cruise at 13,000 lbs., 5,500 lbs of fuel is expended. If the average specific range were 0.2 nmi/lb. the total range would be:

$$\text{Range} = 0.2 \frac{\text{nmi}}{\text{lb}} \times 5,500 \text{ lb} = 1,100 \text{ nmi}$$

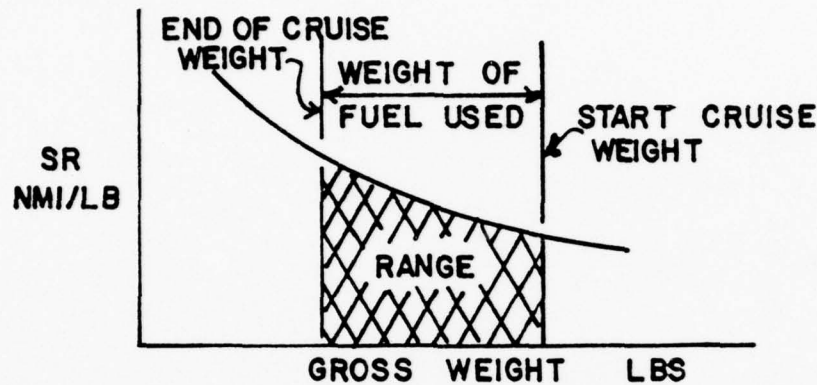

FIG. 4 A-II

Thus, the total range is dependent on both the fuel available and the specific range. When range and economy of operation predominate, the pilot must ensure that the airplane will be operated at the recommended long range cruise condition. By this procedure, the airplane will be capable of its maximum design operating radius or flight distances less than the maximum can be achieved with a maximum of fuel reserve at the destination.

In the previous section it was stated that specific range was the most significant parameter in the study of optimum range characteristics. It was also stated that specific range represented the ratio of true airspeed to fuel flow

$$SR = V_t / W_f \left(\frac{\text{Nmi}}{\text{lb}} \right)$$

and that specific range will vary principally with weight, configuration, standard altitude and airspeed.

Since the W/δ method of fuel consumption flight testing gives us fuel flow data as a function of fuel flow parameter $W_f/$ and Mach number let us look at specific range expressed in terms of Mach number and fuel flow parameter. True airspeed may be expressed in terms of Mach and temperature.

$$V_{t, \text{kts.}} = M \sqrt{\gamma g R T_a} \frac{3600}{6080} \quad (12)$$

Fuel flow may be expressed as:

$$W_f = \frac{W_f}{\delta \sqrt{\theta}} \times \delta \sqrt{\theta} = \frac{W_f}{\delta \sqrt{\theta}} \times \delta \sqrt{\frac{T_a}{T_{ss1}}} \quad (13)$$

Now substituting for V_T and W_f

$$SR = \frac{M \times \sqrt{\gamma g R T_{ss1}}}{\delta \frac{W_f}{\delta \sqrt{\theta}}} = \frac{661 M}{\delta \frac{W_f}{\delta \sqrt{\theta}}} \quad (14)$$

From this we see that SR , for a given W/δ is only a function of pressure altitude (δ), Mach number (M) and fuel flow parameter ($W_f/\delta\sqrt{\theta}$). Note that specific range is not a function of temperature. Remember that

$$\frac{W_f}{\delta \sqrt{\theta}} = f(M, W/\delta) \quad (15)$$

That is, $W_f/\delta\sqrt{\theta}$ is only a function of Mach number and W/δ . Thus from equation 14

$$\text{Specific Range} = f(\delta, M, W/\delta, W_f/\delta\sqrt{\theta}) \quad (16)$$

and is therefore independent of temperature. This permits a plot of specific

range for a given weight and configuration that is a function of pressure altitude and Mach number above, such as figure 4A-12.

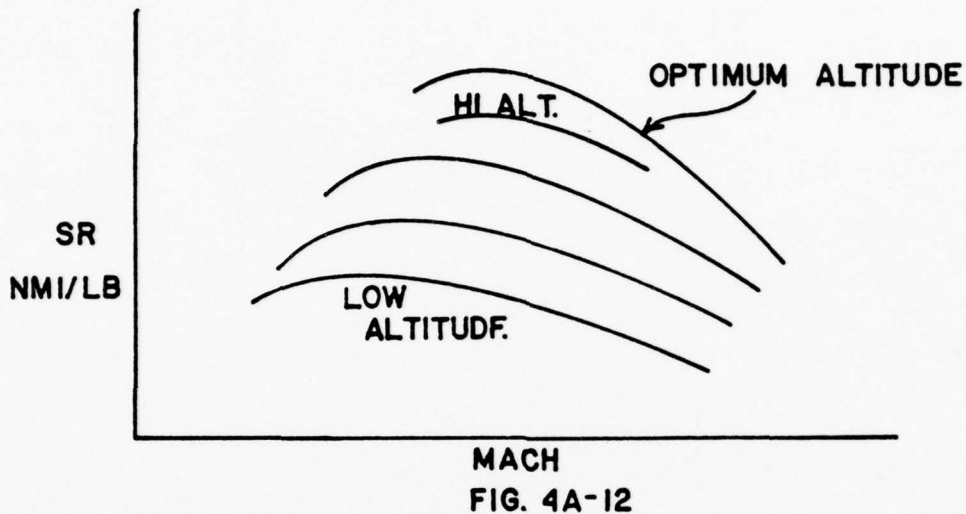

Figure 4A-12 will indicate the airspeed to fly for maximum SR at a particular altitude and even the altitude to fly for maximum SR but the data will represent only one weight. An aircraft does not fly at a constant weight. It flies at a constantly decreasing weight due to fuel usage. This has given rise to the concept of "Cruise Climbs" which will be discussed later.

By rearranging equation 14 slightly, one can say,

$$SR \times \delta = \frac{661 M}{W_f / \delta \sqrt{\sigma}} \quad (17)$$

This equation represents a given W/δ since $W_f / \delta \sqrt{\sigma}$ is a function only of Mach and W/δ (neglecting viscosity) and can be plotted as shown in figure 4A-13.

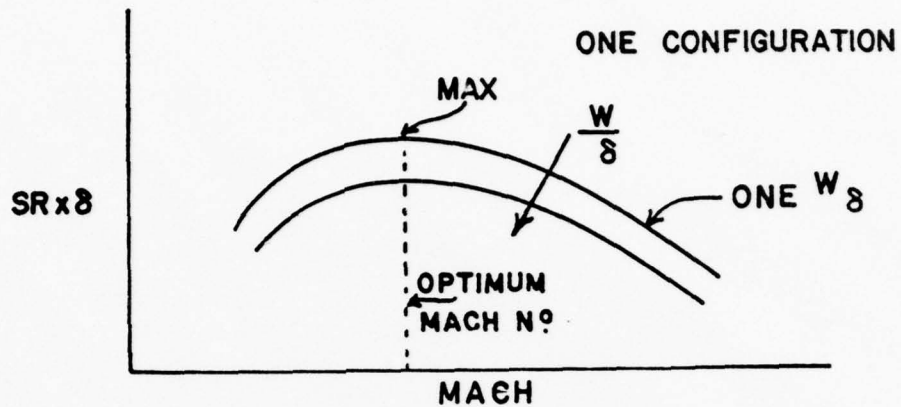
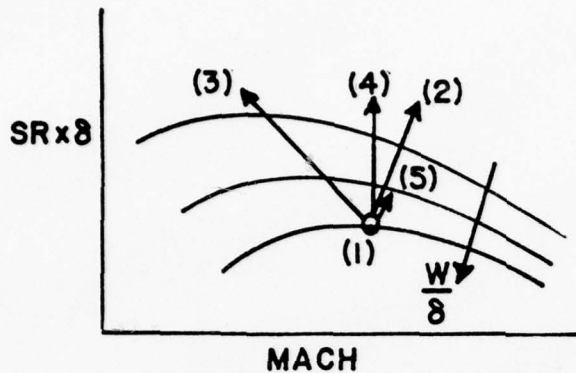

FIG. 4A-13

Study of equation 17 and figure 4A-13 will indicate that for a given W/δ there is a Mach number at which a maximum value of the product of SR and δ will be obtained. At a specified W/δ the fuel state will dictate an altitude which will increase with decrease in fuel load. Since, at the same Mach number, the product of SR and δ will remain constant, the SR will increase as altitude is increased. This is a form of cruise climb and the aircraft remains at the peak of the W/δ curve. Under these conditions M , W/δ , $SR \times \delta$ and several other parameters which will be mentioned later will be maintained constant.

How other types of programmed flight compare to this constant M , W/δ type is shown in figure 4A-14.



- (1) Hold M & W/δ
- (2) Hold RPM & altitude
- (3) Hold altitude & vary Mach to remain on peaks
- (4) Hold alt & Mach
- (5) Hold RPM & V_c

FIG. 4A-14

Schedule (1) is the cruise climb as just described. It is flown at constant W/δ and M and is characterized by an increase in SR and by always remaining at the optimum Mach number. Schedule (1) is a point on figure 4A-14.

Schedule (2) maintains constant altitude and power setting (RPM). At constant altitude W/δ will decrease as W decreases and at constant RPM, M will increase as W decreases. Mach will not be optimum for max specific range even though SR may increase.

Schedule (3) maintains altitude and decreases Mach as W/δ decreases to remain on the peaks of W/δ curves. Mach is always optimum and SR increases but generally not to same extent as Schedule (2).

Schedule (4) maintains constant Mach and altitude and operates at less than optimum Mach at lower W/δ . It may not be too far off from Schedule (3).

Schedule (5) holds constant RPM and calibrated airspeed. As W decreases it will be necessary to climb to maintain constant V_{cal} . Climbing at constant V_{cal} will yield an increase in Mach number which pulls operating point off of optimum for the W/δ . SR will increase with decreased W , but the

increase will generally not be as great as with Schedule (1).

From the above description of various schedules it can be seen that the cruise climb characterized by holding a constant Mach number and W/δ will maintain an operating point which is always at the optimum Mach number for Specific Range. Schedule (3) also maintains an operating point at an optimum Mach number but this represents a decreasing Mach.

Since the thermal efficiencies of thrust are better at higher V_T , the SR under decreasing Mach numbers will not be as good as at a constant Mach number.

Certain of the other schedules may have advantages of simplicity. It is easier, for instance, to fly constant altitude and RPM than to climb at constant M and constant W/δ . Experience has proven, however, that savings in fuel or increases in range can be attained by executing the Cruise Climb. This will be discussed more in the section on Cruise Climb.

The problem of maximizing specific range under conditions of variable gross weight, altitude, et cetera can be considered in the case of the cruise climb holding M and W/δ constant. If M and W/δ are constant, then (neglecting viscosity)

$$\frac{W_f}{\delta \sqrt{\Theta}} = f \left(M, \frac{W}{\delta} \right) = K_1 \frac{W}{\delta} = K_2$$

$$\frac{M}{W_f / \delta \sqrt{\Theta}} = K_1 \quad \text{and} \quad \delta = \frac{W}{K_2}$$

Now from equation 17

$$SR = \frac{661 M}{\delta (W_f / \delta \sqrt{\Theta})}$$

$$SR \approx \frac{dR}{dW} = 661 \frac{K_1 K_2}{W} \quad (18)$$

and

$$dR = 661 K_1 K_2 \frac{dW}{W} \quad (19)$$

Integrating equation (19)

$$R = 661 K_1 K_2 \ln \left(\frac{W_1}{W_2} \right)$$

Or substituting for K_1 and K_2

$$R = 661 \left(\frac{M}{W_f / \delta \sqrt{\Theta}} \right) \times \left(\frac{W}{\delta} \right) \ln \left(\frac{W_1}{W_2} \right) \quad (20)$$

From equation 20, it is seen that for a given fuel weight ($W_1 - W_2$), range (R) will be maximum when the product $\left(\frac{M}{W_f / \delta \sqrt{\Theta}} \times \frac{W}{\delta} \right)$ is maximum. This condition can be determined from plots similar to figure 4A-15.

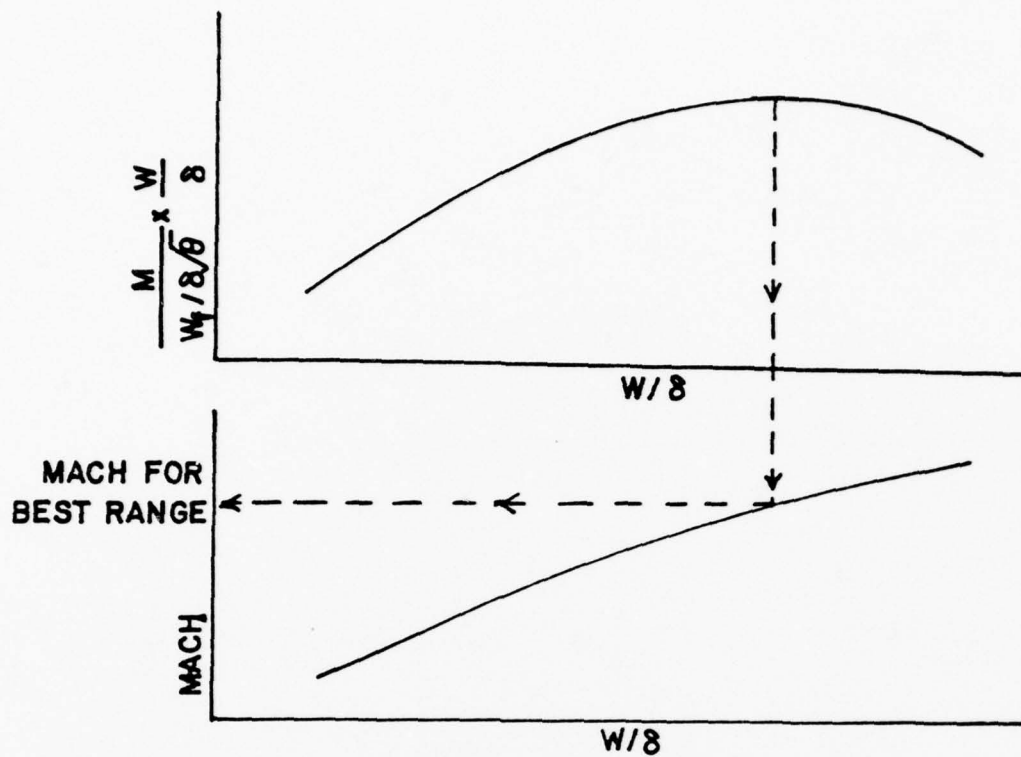

FIG. 4A-15

The product $(M/W_f/\delta\sqrt{\theta}) \times (W/\delta)$, as seen from figure 4A-15 normally increases with W/δ up to an optimum altitude (or W/δ) which is the critical altitude for the engine-airframe and above that the product will drop off due to decreased engine efficiencies. Figure 4A-15 indicates that the Mach number for best range at a particular altitude normally increases with altitude and that the Mach number for best all around range will be fairly high.

Cruise Climb and Control

4B1. INTRODUCTION

"Cruise Climb and Control" of an airplane implies that the airplane is operated to maintain the recommended long range cruise condition throughout the flight. Since fuel is consumed during cruise, the gross weight of the airplane will vary and optimum airspeed, altitude, and power setting can vary. Generally, "cruise control" means the control of optimum airspeed, altitude, and power setting to maintain the maximum specific range condition. At the beginning of cruise, the high initial weight of the airplane will require specific values of airspeed, altitude, and power setting to produce the recommended cruise condition. As fuel is consumed and the airplane gross weight decreases, the optimum airspeed and power setting may decrease or the optimum altitude may increase. In addition, the optimum specific range will also increase. The pilot must provide the proper cruise control technique to ensure that the optimum conditions are maintained.

From the previous analysis, it is apparent that the cruise altitude of the turbojet should be as high as possible within compressibility or thrust limits. Generally, the optimum altitude to begin cruise is the highest altitude at which the maximum continuous thrust can provide the optimum aerodynamic conditions. Of course, the optimum altitude is determined mainly by the gross weight at the beginning of cruise. For the majority of turbojet airplanes this altitude will be at or above the tropopause for normal cruise configurations.

Most turbojet airplanes which have transonic or moderate supersonic performance will obtain maximum range with a high subsonic cruise. However, the airplane designed specifically for high supersonic performance will

obtain maximum range with a supersonic cruise and subsonic operation will cause low lift-drag ratios, poor inlet and engine performance and reduce the range capability.

The cruise control of the turbojet airplane is considerably different from that of the propeller driven airplane. Since the specific range is so greatly affected by altitude, the optimum altitude for begin of cruise should be attained as rapidly as is consistent with climb fuel requirements. The range-climb program varies considerably between airplanes and the performance section of the flight handbook will specify the appropriate procedure. The descent from cruise altitude will employ essentially the same feature, a rapid descent is necessary to minimize the time at low altitudes where specific range is low and fuel flow is high for a given engine speed.

During cruise flight of the turbojet airplane, the decrease of gross weight from expenditure of fuel can result in two types of cruise control. During a constant altitude cruise, a reduction in gross weight will require a reduction of airspeed and engine thrust to maintain the optimum lift coefficient of subsonic cruise. While such a cruise may be necessary to conform to the flow of traffic, it constitutes a certain inefficiency of operation. If the airplane were not restrained to a particular altitude, maintaining the same lift coefficient and engine speed would allow the airplane to climb as the gross weight decreases. Since altitude generally produces a beneficial effect on range, the climbing cruise implies a more efficient flight path.

The cruising flight of the turbojet airplane will begin usually at or above the tropopause in order to provide optimum range conditions. If flight is conducted at $(C_L^{1/2}/C_D)_{MAX}$, optimum range will be obtained at specific

values of lift coefficient and drag coefficient. When the airplane is fixed at these values of C_L and C_D and the TAS is held constant, both lift and drag are directly proportional to the density ratio, σ . Also, above the tropopause, the thrust is proportional to σ when the TAS and RPM are constant. As a result, a reduction of gross weight by the expenditure of fuel would allow the airplane to climb but the airplane would remain in equilibrium because lift, drag, and thrust all vary in the same fashion. This relationship is illustrated by figure 4B-1.

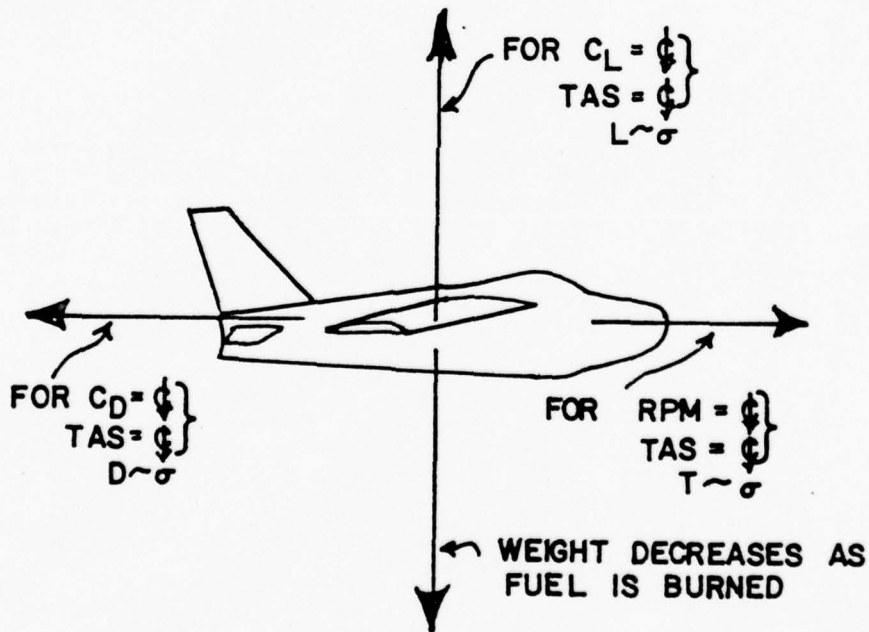

FIG. 4B-1

The relationship of lift, drag, and thrust is convenient for, in part, it justified the condition of a constant velocity. Above the tropopause, the speed of sound is constant hence a constant velocity during the cruise-climb would produce a constant Mach number. In this case, the optimum values of $(C_L^{1/2}/C_D)$, C_L and C_D do not vary during the climb since the Mach number is constant. The specific fuel consumption is initially constant above the tropopause but begins to increase at altitudes much above the tropopause. If the specific fuel consumption is assumed to be constant during the cruise-climb, the following relationships will apply:

V , M , C_L and C_D are constant

$$\frac{\sigma_2}{\sigma_1} = \frac{W_2}{W_1}$$

$$\frac{FF_2}{FF_1} = \frac{\sigma_2}{\sigma_1}$$

$$\frac{SR_2}{SR_1} = \frac{W_1}{W_2} \quad (\text{cruise climb above tropopause, constant } M, c_t)$$

where

conditions (1) applies to some known condition of weight, fuel flow, and specific range at some original basic altitude during cruise climb.

condition (2) applies to some new values of weight, fuel flow, and specific range at some different altitude along a particular cruise path.

and

V = velocity, knots

M = Mach number

W = gross weight, lbs.

FF = fuel flow, lbs/hr.

SR = specific range, nmi./lb.

σ = altitude density ratio

Thus, during a cruise-climb flight, a 10 percent decrease in gross weight from the consumption of fuel would create:

no change in Mach number of TAS

a 5 percent decrease in EAS

a 10 percent decrease in σ , i.e., higher altitude

a 10 percent decrease in fuel flow

an 11 percent increase in specific range

An important comparison can be made between the constant altitude cruise and the cruise-climb with respect to the variation of specific range. From the previous relationships, a 2 percent reduction in gross weight during

$$\frac{SR_2}{SR_1} = \sqrt{\frac{W_1}{W_2}} \quad \text{constant altitude}$$

$$\frac{SR_2}{SR_1} = \frac{W_1}{W_2} \quad \text{cruise-climb}$$

cruise would create a 1 percent increase in specific range in a constant altitude cruise but a 2 percent increase in specific range in a cruise-climb at constant Mach number. Thus, a higher average specific range can be maintained during the expenditure of a given increment of fuel. If an airplane begins a cruise at optimum conditions at or above the tropopause with a given weight of fuel, the following data provide a comparison of the total range available from a

constant altitude or cruise-climb flight path.

Ratio of cruise fuel weight to airplane gross weight at beginning of cruise	Ratio of cruise-climb range to constant altitude cruise range
0.0	1.000
.1	1.026
.2	1.057
.3	1.092
.4	1.136
.5	1.182
.6	1.248
.7	1.331

For example, if the cruise fuel weight is 50 percent of the gross weight, the climbing cruise flight path will provide a range 18.2 percent greater than cruise at constant altitude. This comparison does not include consideration of any variation of specific fuel consumption during cruise or the effects of compressibility in defining the optimum aerodynamic conditions for cruising flight. However, the comparison is generally applicable for aircraft which have subsonic cruise.

When the airplane has a supersonic cruise for maximum range, the optimum flight path is generally one of a constant Mach number. The optimum flight path is generally - but not necessarily - a climbing cruise. In this case of subsonic or supersonic cruise, a Machmeter is of principal importance in cruise control of the jet airplane.

4B-2. CRUISE CLIMB AND CONTROL SCHEDULES

In the previous section on specific range the concept of the "Cruise Climb" was introduced. The phrase, "Cruise Climb" is used in aeronautical literature to apply to various types of flight programs designed to improve overall maximum range for a given fuel load. As used in this section, Cruise Climb will refer to a flight programmed to maintain a constant M and W/δ .

To determine how one can fly a schedule of constant Mach number and W/δ , all factors which are constant when M & W/δ are constant. From the lift equation:

$$C_L = \frac{2W}{\gamma P_a M^2 S} = \frac{2 W/\delta}{\gamma M^2 S \rho_{ssl}} \quad (1)$$

Equation (1) indicates that

$$C_L = f(W/\delta, M^2) \quad (2)$$

since γ , ρ_{ssl} and S are constant. If in a cruise climb, W/δ and M are constant then

$$C_L = \text{const.}$$

Inasmuch as C_L is also a function of angle of attack and Mach number

$$C_L = f(\alpha, M) \quad (3)$$

then

$$\alpha = \text{const.}$$

For steady, level flight, neglecting viscosity

$$\frac{D}{\delta} = f(M, W/\delta) \quad (4)$$

Therefore D/δ must be constant. The ratio of two constants must be constant so

$$\frac{W/\delta}{D/\delta} = \frac{W}{D} \text{ constant}$$

But $W = L$ in steady level flight and thus

$$L/D = \text{constant.}$$

From this, C_L/C_D and C_D are constant.

Neglecting viscosity, for a constant area engine the following parameters are functions of Mach number and W/δ and are therefore constant:

$N/\sqrt{\theta}$	constant (RPM, Temp)
T_G/δ	constant (Gross Thrust/Pressure)
P_{t_7}/P_a	constant (Exit Press./Pressure)
$W_f/\delta\sqrt{\theta}$	constant (Fuel Flow/Press.-Temp)

From a previous section it was noted that specific range parameter is also constant

$$SR \times \delta = \text{constant}$$

or

$$\frac{M/W_f}{\delta\sqrt{\theta}} = \text{constant}$$

Since

$$\text{TSFC} = \frac{W_f}{T} = \frac{\frac{W_f}{\delta\sqrt{\theta}} \times \delta\sqrt{\theta}}{\frac{T}{\delta} \times \delta} \quad (5)$$

and $W_f\delta\sqrt{\theta}$ and T/δ are constant, therefore

$$\text{TSFC}/\sqrt{\theta} = \text{constant}$$

This could possibly be continued "ad infinitum" but the list is imposing enough. Of this list, however, there are very few constant parameters which are easily measured or indicated to an engineer. The Mach number, α , H_{P_i} , RPM, fuel remaining, T_G and T_G/δ can be read from cockpit instruments so a pilot would be able to fly the following type schedules

- a. constant α and M
- b. constant W/δ and M
- c. constant T_G/δ and M
- d. constant $N/\sqrt{\theta}$ and M
- e. constant T_G/δ and $N/\sqrt{\theta}$ in isothermal layer
- f. other variations or combinations of the above.

Flight testing has indicated that schedule (b) produce the best results with the instrumentation available. A slight modification of schedule (d) with schedule (b) was also recommended as suitable. For variable area engines schedule (c) appeared to have the greatest promise.

Increases in cruising ranges of from 5-6% can be realized using cruise climb techniques as compared to level flight procedures. Increases of up to 10% in cruising range are theoretically possible but were not realized during

the project. The concept was declared service suitable and its use was recommended to the fleet. Data required for cruise climb is obtainable during normal level flight testing. Pre-flight preparation for cruise climb is a requirement and special cards and charts must be prepared. Of the two factors, altitude and Mach, Mach is the most critical and must be maintained on the assigned value.

Figure 4B-2 shows several flight profiles utilizing both level flight and cruise climb procedures from varying initial altitudes. Fuel used in the climb is factored into the plot and lines indicating various values of fuel remaining interconnect the various profiles for ease of comparison.

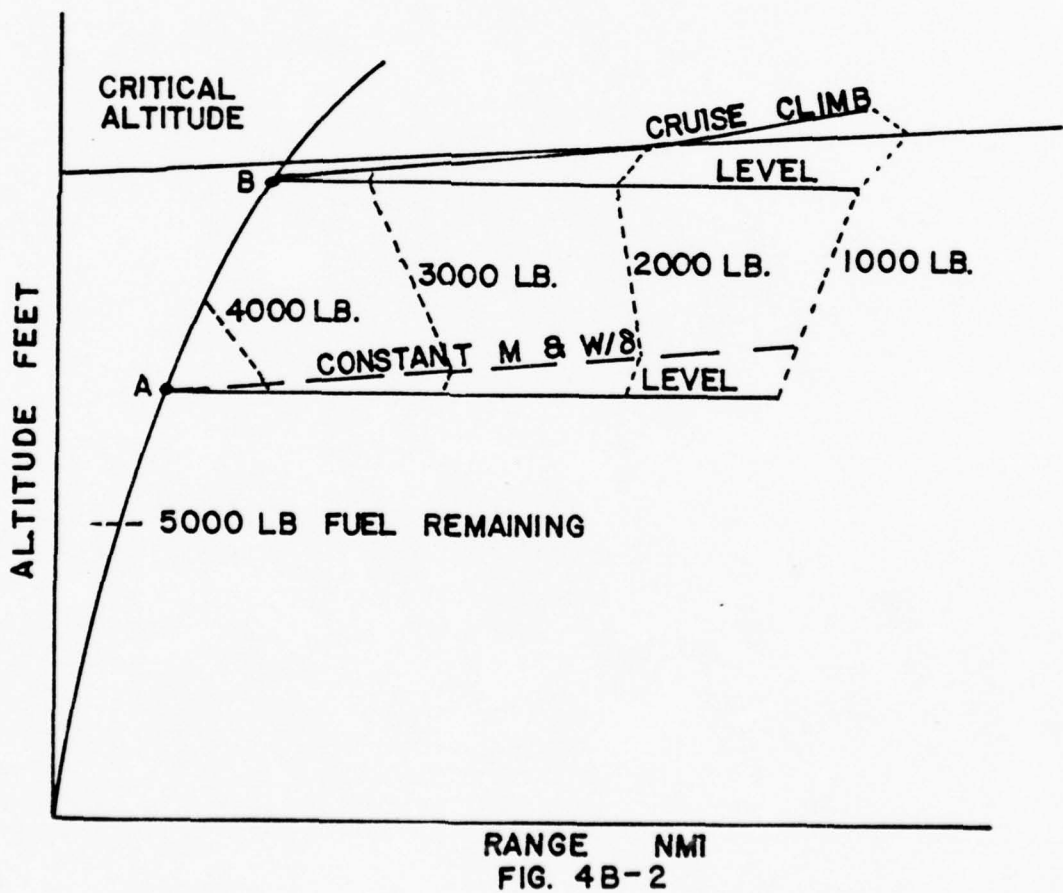

It is seen that climbing to altitude B and flying either cruise climb or constant altitude will produce a better overall range than either schedule from altitude A. At altitude A the cruise climb schedule represents an improvement over the level flight schedule. From altitude B, the cruise climb represents an improvement over level flight up to that altitude at which Specific Range decays with further increase in altitude. At this point it would be preferable to fly a schedule such as schedule (3) on figure 4A-14 such that Mach is reduced to remain at the Mach number for max specific range at that W/δ .

Unit 4-C

Endurance Performance

4C-1. INTRODUCTION

The general item of endurance must be clearly distinguished from the item of range. The item of endurance involves consideration of time. Thus, it is appropriate to define a separate term, "specific endurance."

$$\text{specific endurance} = \frac{\text{flight hours}}{\text{lb. of fuel}}$$

or,

$$\text{specific endurance} = \frac{\text{flight hours/hr.}}{\text{lbs. of fuel/hr.}}$$

then,

$$\text{specific endurance} = \frac{1}{\text{fuel flow, lbs. per hr.}}$$

By this definition, the specific endurance is simply the reciprocal of the fuel flow. Thus, if maximum endurance is desired, the flight condition must provide a minimum of fuel flow. This point is readily appreciated as the lowest point of the curve of fuel flow versus velocity.

Maximum endurance will be achieved under those flight conditions requiring the least expenditure of fuel per unit time, i.e., that altitude and speed at which fuel flow, W_f , is at its absolute minimum required to sustain flight. This condition will be determined by the desires (or requirements) of the airframe and the JP appetite of the engine. Airframes in general prefer low altitudes for maximum endurance. From the standpoint of only the airframe, maximum endurance would be achieved at the speed for minimum THP required and this minimum value as well as the speed at which it occurs decreases as the altitude is decreased. This point of minimum THP furthermore corresponds to that flight condition at which $(C_L^{3/2}/C_D)$ is a maximum. Thus for maximum endurance the airframe would like to stay low and slow.

4C-2. TURBOJET AIRCRAFT ENDURANCE

Since the fuel flow of the turbojet powered airplane is proportional to thrust required, the turbojet airplane will achieve maximum specific endurance when operated at minimum thrust required or $(L/D)_{\max}$. In subsonic flight, $(L/D)_{\max}$ occurs at a specific value of lift coefficient for a given airplane and is essentially independent of weight or altitude. If an airplane of given weight and configuration is operated at various altitudes, the value of the minimum thrust required is unaffected as shown in figure 4C-1. Hence, it is apparent that the aerodynamic configuration has no preference for altitude (within compressibility limits) and specific endurance is a function only of engine performance.

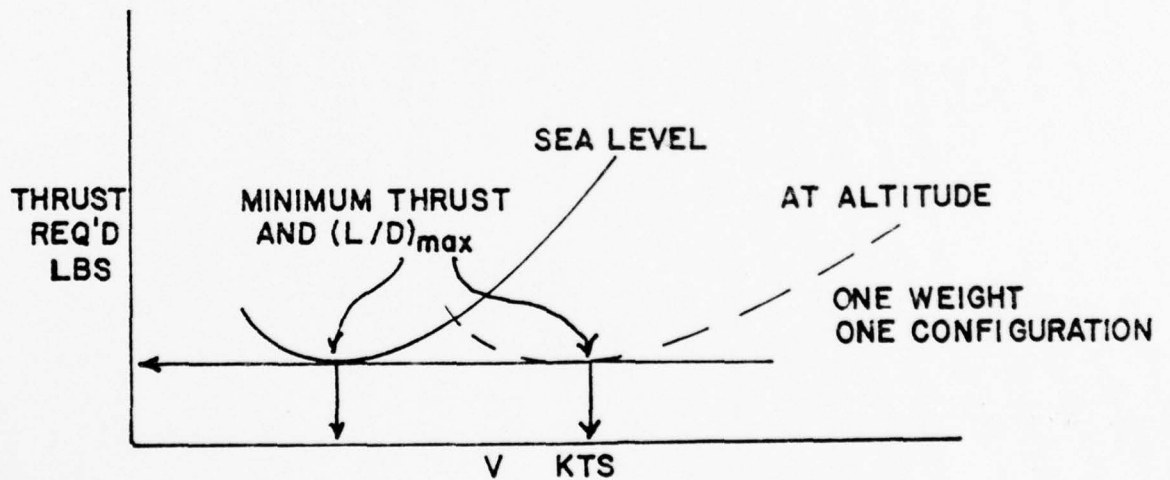

FIG. 4C-1

The specific fuel consumption of the turbojet engine is strongly affected by operating RPM and altitude. Generally, the turbojet engine prefers the operating range near normal rated engine speed and the low temperatures of the stratosphere to produce low specific fuel consumption. Thus, increased altitude provides the favorable lower inlet air temperature and requires a greater engine speed to provide the thrust required at $(L/D)_{\max}$. The typical turbojet airplane experiences an increase in specific endurance with altitude with the peak values occurring at or near the tropopause. For example, a typical single-engine turbojet airplane will have a maximum specific endurance at 35,000 ft. which is at least 40 percent greater than the maximum value at sea level. If the turbojet airplane is at low altitude and it is necessary to hold for a considerable time, maximum time in the air will be obtained by beginning a climb to some optimum altitude dependent upon the fuel quantity available. Even though fuel is expended during the climb, the higher altitude will provide greater total endurance. Of course, the use of afterburner for the climb would produce a prohibitive reduction in endurance.

The engine characteristic for a turbo-jet engine which has the most effect on endurance considerations is thrust specific fuel consumption, $TSFC = \frac{\text{lb fuel/hr}}{\text{lb thrust net}}$. TSFC varies with thrust, airspeed, altitude and temperature, but generally speaking it is fairly constant for turbo-jets operating in cruising ranges at a particular altitude. A typical curve of TSFC might look like figure 4C-2.

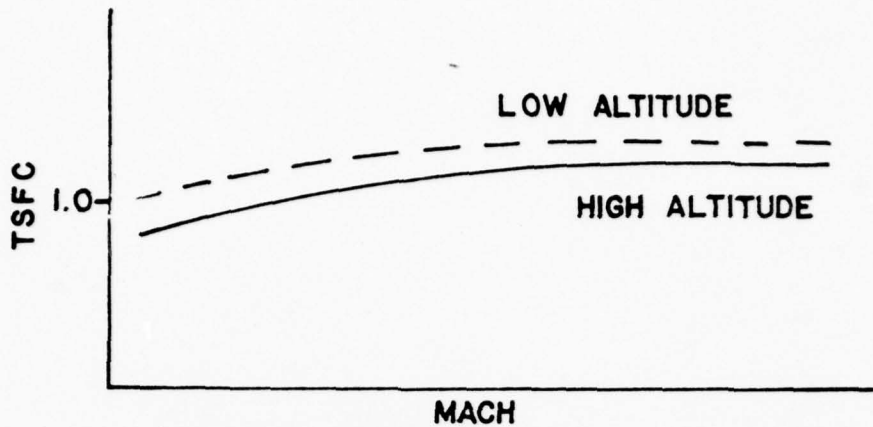

FIG. 4C-2

If TSFC is a constant, it may be shown that the endurance of a jet aircraft (in hours) is

$$E = \frac{1}{\text{TSFC}} \left(\frac{C_L}{C_D} \right) \log_e \left(\frac{W_0}{W_1} \right) \quad (1)$$

Figure 4C-2 indicates that TSFC decreases as altitude is increased and slightly decreases as airspeed decreases but is fairly constant at cruise airspeeds. If thrust specific fuel consumption, which is W_f/T , is fairly constant, then minimum fuel flow will correspond to the point of minimum thrust.

$$\text{TSFC} = \frac{W_f}{T} = K_1 \quad (2)$$

$$(W_f)_{\min} = K_1 (T)_{\min} \quad (3)$$

Thus the engine would prefer to operate at high altitudes for minimum TSFC and at a particular altitude would like to operate at a speed fairly close to the point of minimum thrust required (or drag). The speed for minimum thrust required corresponds to that flight condition at which $(C_L/C_D)_{\max}$

and occurs at a speed greater than minimum THP_r .

It is obvious that endurance considerations for the turbo-jet engine-airframe combination must represent a compromise between the desires of each. Engine effects are normally stronger than airframe effects and maximum endurance conditions usually are found at high altitudes and at airspeeds fairly close to minimum drag or $(C_L/C_D)_{max}$.

It was mentioned above that turbo-jets normally decrease TSFC with increase in altitude. It is necessary to qualify this statement with the provision that this is only so up to the so-called "critical" altitude of the engine. At altitudes above critical, engine efficiencies decay with further increase in altitude resulting in increase in TSFC and therefore decay in endurance. For present day engines critical altitude usually occurs fairly close to the beginning of the isothermal layer (36,089 feet).

It is important to remember that the endurance considerations mentioned above are all predicated upon steady level flight at a particular altitude. A very essential piece of information required to complete the endurance picture is the fuel required to climb to the altitude at which optimum level flight endurance is obtained. Under many circumstances it will be more advantageous for overall endurance to remain at a lower altitude than to expend fuel for climbing. By compiling climb fuel consumption data with level flight endurance data, guide lines can be established to assist in making decisions to climb or maintain altitude.

Now that we have discussed some of the theoretical aspects of endurance let's look at the practical side. How does one determine endurance figures by flight test? Very simply - record fuel flow during level flight testing by

the W/δ or similar method. If the data generalizes well, a plot of fuel flow versus airspeed such as figure 4C-3 can be constructed for various altitudes for a given weight and configuration.

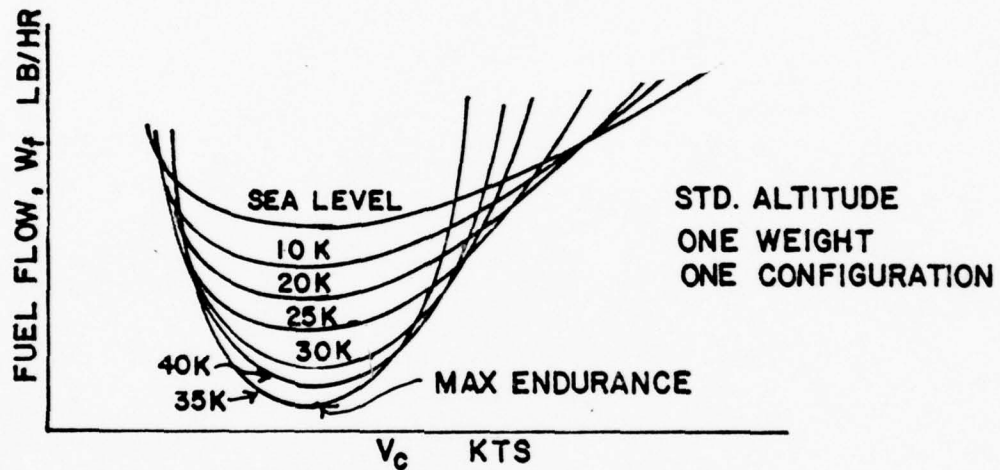

FIG. 4C-3

That altitude and airspeed at which to obtain maximum endurance (minimum W_f) will be readily apparent as will be the airspeed for optimum endurance at any altitude. A plot such as this marries the airframe and engine together and produces a legitimate offspring which is a reflection of both of its parents but which favors the characteristics of the stronger influence.

Pilot abilities and desires should also be considered, and a "recommended" maximum endurance airspeed may be chosen in preference to an actual speed for maximum endurance. Proximity to the region of "reversed power command" may well dictate a recommended airspeed which is faster than the actual airspeed.

A slightly different form of data presentation may be useful in selecting the power setting and altitude for maximum endurance on constant geometry engines is shown in figure 4C-4.

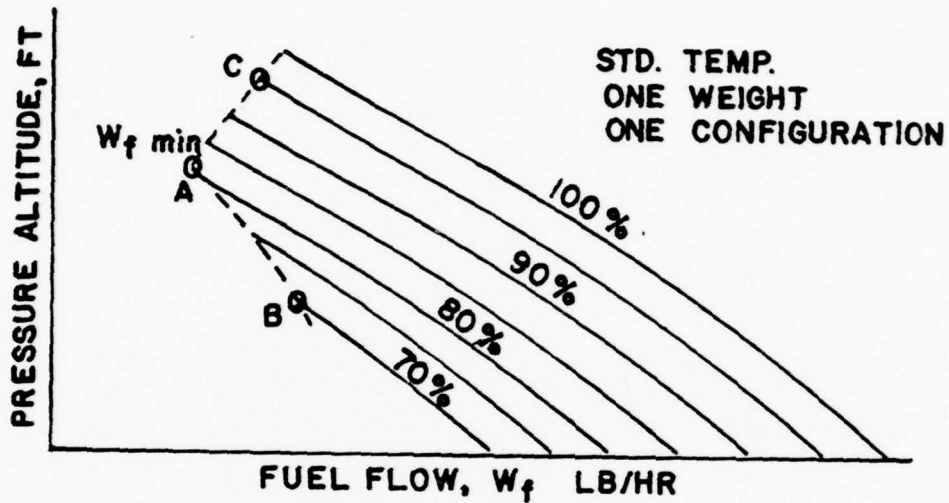

FIG. 4C-4

This presentation quickly indicates the power setting in percent of RPM and the altitude at which to obtain minimum fuel flow (point A). Lower RPM will not sustain the airplane in level flight without reduction in altitude and resultant increase in fuel flow (point B). Higher RPM will sustain the plane at higher altitudes but W_f is greater (point C).

4C-3 PROPELLER AIRCRAFT RANGE

If it is assumed that the specific fuel consumption and the propeller efficiency have constant average values, the endurance in hours is expressed by

$$E = 778 \frac{\eta_p}{c} \left(\frac{C_L^{3/2}}{C_D} \right) \sqrt{\rho S} \left[\frac{1}{\sqrt{W_1}} - \frac{1}{\sqrt{W_0}} \right] \quad (4)$$

An airframe will have the least THP_r at a particular angle of attack which is independent of weight and altitude and where $(C_L^{3/2}/C_D)$ is greatest.

$(C_L^{3/2}/C_D)$ will be greatest when THP_r is least on the plots of Figure 4C-5. These plots indicate that "airframes" require minimum THP at low altitude and thus "prefer" a low altitude for maximum endurance.

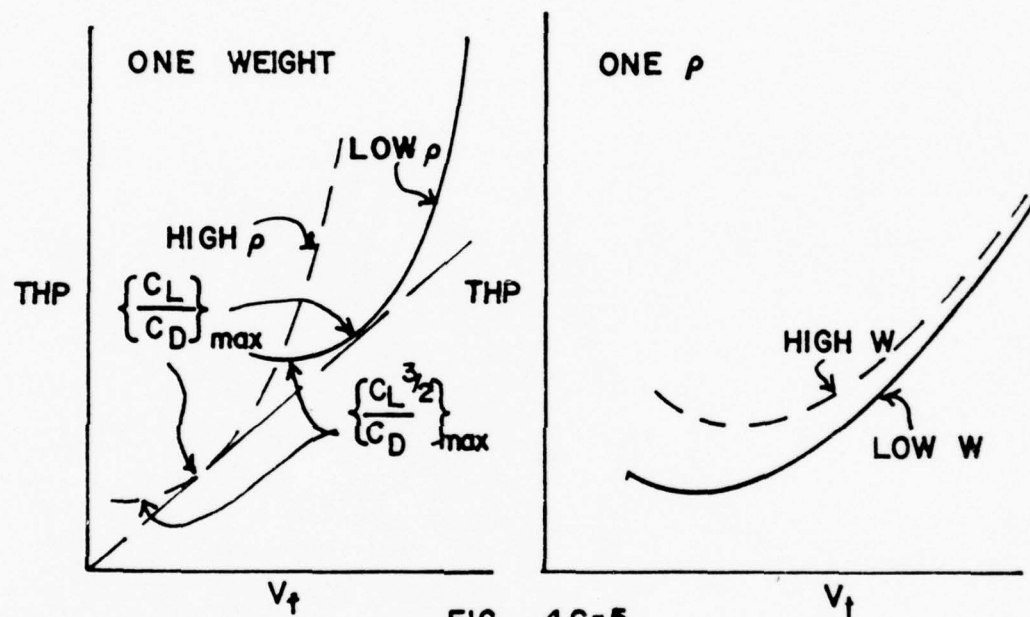
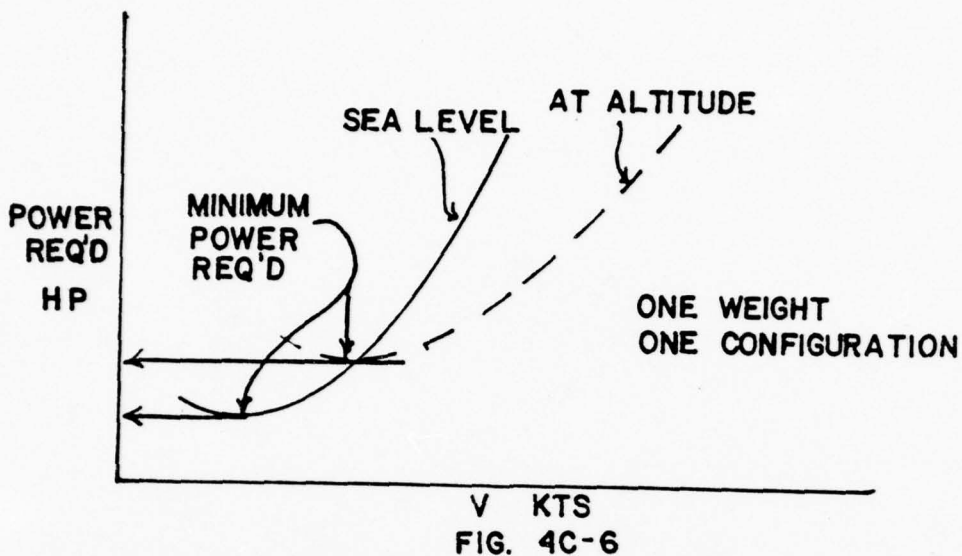

FIG. 4C-5

The curve at right shows that the airframe requirements for maximum endurance are optimized at light weights; and that when weight is increased, the optimum speed for endurance (V_t) is greater. In short, airframe's optimum conditions for maximum endurance are (1) light weight, (2) high density (low altitude), and (3) speed for minimum THP required $(C_L^{3/2}/C_D)_{max}$.

Power plants alone obviously demand only low fuel flow. This would be achieved at idle. To be realistic in our consideration of power plants for conditions of endurance we have to partially "marry" the airframe and engine because we must require that the power developed is adequate to sustain level flight at or near the speed of minimum THP required. For maximum endurance with any power plant we want a power setting which will give minimum fuel flow in pounds per hour. In a reciprocating engine we have a propeller pitch control through which we can alter the internal pressures of the engine. Best fuel consumption characteristics are usually obtained when we maintain a maximum allowable BMEP. We do this as we vary power by holding a minimum specified RPM with each manifold pressure setting. If we follow this pre-set "power schedule" as we decrease power and likewise operate the mixture control in a similar predetermined, fixed schedule, a repeatable plot of BHP versus W_f will result as power is varied. (A slightly different plot will result as altitude is varied, but, in general, the slight gains in fuel flow at higher altitudes do not make it profitable to increase airplane altitude because higher BHP's are required there.

Since the fuel flow of the propeller driven airplane is proportional to power required, the propeller powered airplane will achieve maximum specific endurance when operated at minimum power required. The point of minimum power required is obtained at a specific value of lift coefficient for a particular airplane configuration and is essentially independent of weight or altitude. However, an increase in altitude will increase the value of the minimum power required as illustrated by figure 4C-6.



If the specific fuel consumption were not influenced by altitude or engine power, the specific endurance would be directly proportional to $\sqrt{\sigma}$, e.g., the specific endurance at 22,000 ft. ($\sigma = 0.498$) would be approximately 70 percent of the value at sea level. This example is very nearly the case of the airplane with the reciprocating engine since specific fuel consumption and propeller efficiency are not directly affected by altitude. The obvious conclusion is that maximum endurance of the reciprocating engine airplane is obtained at the lowest practical altitude.

The variation with altitude of the maximum endurance of the turboprop airplane requires consideration of powerplant factors in addition to airplane factors. The turboprop powerplant prefers operation at low inlet air temperatures and relatively high power setting to produce low specific fuel consumption. While an increase in altitude will increase the minimum power

required for the airplane, the powerplant achieves more efficient operation. As a result of these differences, maximum endurance of the multiengine turbo-prop airplane at low altitudes may require shutting down some of the powerplants in order to operate the remaining powerplants at a higher, more efficient power setting.

SUPPLEMENTARY PROBLEMS

Unit 4

The F-4J Phantom has the following characteristics:

Number of engines = 2

$T = 11,000$ lbs/engine

$S = 530$ ft²

$e = 0.935$

$C_{D_0} = 0.032$

TSFC = 0.8 lb fuel/lb thrust-hr

$b = 38.4$ ft

$W_{\text{empty}} = 29,500$ lb

$W_{\text{max}} = 52,000$ lb

$W_{\text{ordnance}} = 2,000$ lb

1. An F-4J aircraft takes off from a carrier and flies to the Bomb Safe Line (Point Y). From this point it flies at maximum range at sea level to the target (Point X), drops its ordnance and returns to Point Y. It then rejoins carrier and lands. The following fuel requirements exist.

Carrier to Point Y 4,000 lbs

Point Y to Carrier 3,000 lbs

Reserve upon return to carrier 1,500 lbs

Can this aircraft complete the mission if the distance from Point Y to Point X is 390 miles?

SUPPLEMENTARY PROBLEMS

SOLUTION SHEET

UNIT 4

1. At point Y (inbound) the aircraft weight is

$$\begin{array}{r} 52,000 \text{ lb (full weight)} \\ - 4,000 \text{ lb (Fuel to Point Y)} \\ \hline 48,000 \text{ lb} \end{array}$$

At Point Y (return) the aircraft weight must be

$$\begin{array}{r} 29,500 \text{ lb (Empty weight)} \\ + 1,500 \text{ lb (Reserve fuel)} \\ + 3,000 \text{ lb (Fuel from Point Y to carrier)} \\ \hline 34,000 \text{ lb} \end{array}$$

The problem now is, can the F-4J fly 390 miles, drop 2,000 lb of ordnance and return 390 miles with an initial weight of 48,000 lb and a final weight of 34,000 lb?

The equation for maximum range at a constant altitude is, (Eq. (10), 4-A):

$$R_{\text{nmi}} = \frac{1.675}{\text{TSFC} \sqrt{\rho S}} \frac{C_L^{3/2}}{C_D} (\sqrt{W_0} - \sqrt{W_1})$$

First, one must determine $C_L^{3/2}/C_D$ for this aircraft. The drag coefficient is given by

$$C_D = C_{D_0} + \frac{C_L^2}{\pi AR e} \quad \text{where } AR = b^2/S$$

$$\frac{1}{\pi AR e} = \frac{1}{3.1416 \times ((38.4)^2/530) \times 0.935} = 0.122$$

so that

$$C_D = 0.032 + 0.122 C_L^2$$

Maximum range occurs where $C_{D_0} = 3 C_{D_i}$, or

$$0.032 = 3 \times 0.122 C_L^2$$

and

$$C_L = 0.296$$

$$\frac{C_L^{3/2}}{C_D} = \frac{(0.296)^2}{0.032 + 0.122 \times (0.296)^2} = 12.74$$

SUPPLEMENTARY PROBLEMS

SOLUTION SHEET

UNIT 4

(Cont)

1. (Continued)

The range equation now reduces to:

$$R_{\text{mni}} = \frac{1.675}{0.8 \times (0.0023769 \times 530)^{\frac{1}{2}}} \times 12.74 \times (\sqrt{W_0} - \sqrt{W_1})$$

$$= 23.77 (\sqrt{W_0} - \sqrt{W_1})$$

For the leg from Point Y in to the target, the initial weight (W_0) and the final Weight (W_1) are

$$W_0 = 48,000 \text{ lb} \qquad W_1 = W_x \text{ lb}$$

For the leg from the target (after the ordnance is dropped) back to Point Y the weights are

$$W'_0 = W_x - 2,000 \text{ lb} \qquad W'_1 = 34,000 \text{ lb}$$

Inasmuch as the range is the same inbound and outbound, from the range equation

$$\sqrt{W_0} - \sqrt{W_1} = \sqrt{W'_0} - \sqrt{W'_1}$$

or

$$\sqrt{48,000} - \sqrt{W_x} = \sqrt{W_x - 2,000} - \sqrt{34,000}$$

There are many ways to solve the above equation, and one method is by the use of a graphical iterative approximation.

If the equation is rewritten as

$$\sqrt{(48,000 - \sqrt{W_x})} - \sqrt{(W_x - 2,000 - \sqrt{34,000})} = \text{DIFF}$$

one can seek a value of W_x that will make DIFF = 0. To do this, assume various values for W_x and plot the trend of DIFF versus W_x .

One possible first assumption would be that W_x is one-half the difference in Point Y weights. Taking one-half the sum

$$W_{x1} = \frac{1}{2}(48,000 + 34,000) = 41,000 \text{ lb}$$

and

$$(\sqrt{48,000} - \sqrt{41,000}) - (\sqrt{41,000 - 2,000} - \sqrt{34,000}) = 3.51$$

With a positive value of DIFF, there is an indication that the first approximation of W_x was too low. Therefore assume

$$W_{x2} = 42,000 \text{ lb}$$

$$(\sqrt{48,000} - \sqrt{42,000}) - (\sqrt{42,000 - 2,000} - \sqrt{34,000}) = -1.46$$

SUPPLEMENTARY PROBLEMS

SOLUTION SHEET

UNIT 4

(Cont)

1. (Continued)

Plotting these values of DIFF vs W_x shows

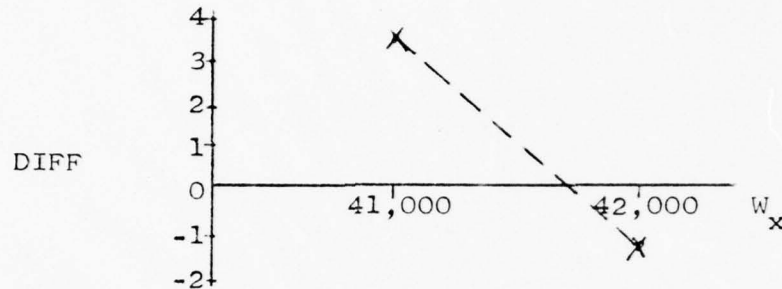

The intercept of the plotted line is at

$$\left(\frac{3.51}{3.51 - (-1.46)} \times 1,000 \right) + 41,000 = 41,706 \text{ lb}$$

Check:

$$48,000 - 41,706 = 14.87$$

$$41,706 - 2000 - 34,000 = 14.87$$

The maximum range at constant sea level altitude is

$$R_{\text{nmi}} = 23.77 \times 14.87 = 353 \text{ nmi}$$

The aircraft CAN NOT fly the proposed 390 mile track.

2. The maximum range the F-4F can fly from Point Y to Point X, drop the ordnance and return is 353 nmi (as shown in the solution to Problem 1.

3. From Eq. (1), 4-C, the endurance of a jet aircraft in hours is

$$E_{\text{hrs}} = \frac{1}{\text{TSFC}} \frac{C_L}{C_D} \ln \frac{W_0}{W_1}$$

Maximum endurance will be at $(C_L/C_D)_{\text{MAX}}$, which occurs when $C_{D_0} = C_{D_i}$. From Problem 1, $C_{D_0} = 0.032$ and $C_{D_i} = 0.122 C_L^2$

therefore, $C_L = (.032/0.122)^{1/2} = 0.512$

and

$$\left(\frac{C_L}{C_D} \right)_{\text{MAX}} = \frac{0.512}{2 \times 0.032} = 7.97$$

SUPPLEMENTARY PROBLEMS

SOLUTION SHEET

UNIT 4

(cont)

3. (Continued)

The maximum endurance in MINUTES is

$$E_{\text{minutes}} = 60 \times \frac{1}{0.8} \times 7.97 \times \ln \frac{W_0}{W_1}$$

For Option a:

$$W_0 = \begin{array}{l} 29,500 \text{ lb} + 3,500 \text{ lb} + 2,000 \text{ lb} = 35,000 \text{ lb} \\ \text{(Dry)} \qquad \qquad \text{(Fuel)} \qquad \qquad \text{(Ord)} \end{array}$$

$$W_1 = \begin{array}{l} 29,500 \text{ lb} + 1,500 \text{ lb} + 2,000 \text{ lb} = 33,000 \text{ lb} \\ \text{(Dry)} \qquad \qquad \text{(Res)} \qquad \qquad \text{(Ord)} \end{array}$$

and

$$E_a = 60 \times \frac{1}{0.8} \times 7.97 \times \ln \frac{35,000}{33,000} = 35 \text{ minutes}$$

For Option b:

$$W_0 = 29,500 \text{ lb} + 3,500 \text{ lb} = 33,000 \text{ lb}$$

$$W_1 = 29,500 \text{ lb} + 1,500 \text{ lb} = 31,000 \text{ lb}$$

and

$$E_b = 60 \times \frac{1}{0.8} \times 7.97 \times \ln \frac{33,000}{31,000} = 37 \text{ minutes}$$

For Option c:

$$W_0 = 29,500 \text{ lb} + 3,500 \text{ lb} = 33,000 \text{ lb}$$

$$W_1 = 29,500 \text{ lb} + 500 \text{ lb} = 30,000 \text{ lb}$$

and

$$E_c = 60 \times \frac{1}{0.8} \times 7.97 \times \ln \frac{33,000}{30,000} = 57 \text{ minutes}$$

Only Option c is viable in view of the projected 45 minute delay.

AE-2306
PERFORMANCE II
UNIT 5
Maneuvering Flight

PERFORMANCE II

Unit 5 - Maneuvering, Instantaneous Maneuverability, Tactical Performance
OBJECTIVE

As a result of your work in this Unit, you should be able to:

1. Draw a free-body diagram of an aircraft in level turning flight showing the components of lift, weight, and centrifugal force.
2. From the free-body diagram, derive the equation for radius of turn (R) in terms of velocity and angle of bank. (Eq. (8), Section 5-A).
3. State the relationship between normal acceleration and the angle of bank in a constant velocity, level turn.
4. Using the fact that $\sec^2 x = 1 + \tan^2 x$, convert the equation for radius of turn to an equation containing velocity and normal acceleration terms.
5. Explain how instantaneous maneuvering performance ($n_{z_{MAX}}$) varies with Mach number.
6. Discuss the effects of dynamic pressure (q) and wing loading (W/S) on the effectiveness of vectored thrust on $n_{z_{MAX}}$.
7. Draw a radius of turn versus velocity plot showing the aerodynamic and structural limits and the maneuver speed point.
8. Determine maneuver speed, given the stall speed and the limit load factor.
9. Draw a V-n diagram, given V_S , n_L , and V_{MAX} .
10. Indicate on the V-n diagram V_p , area of low speed buffet and area of high speed buffet.
11. Define Service, Operational and Permissible flight envelopes.

AE 2306

PERFORMANCE II

Unit 5

PROCEDURE

1. Read Sections 5-A, 5-B and 5-C.
2. Review the Statement of Objectives.
3. Answer the Study Questions.
4. Review the resource material as necessary, based on your difficulty with the Study Questions.

When you are ready, ask for the written test on this Unit. This test will be Closed Book.

STUDY QUESTIONS

1. What is the percentage increase in lift required in a constant velocity, level flight turn at bank angles of 30° , 45° and 60° ?
2. What is the limiting factor on radius of turn at velocities below the maneuver speed?
3. What is the limiting factor on the radius of turn at velocities greater than the maneuver speed?
4. On a V-n diagram, how does the aerodynamic limit load factor vary with velocity?
5. A 10,000 lb aircraft with a wing area of 200 ft^2 has a limit load factor of 8 and a maximum lift coefficient of 1.1. What is the velocity in knots for minimum turn radius at sea level?
6. What is the maneuver speed in knots Equivalent air speed for the aircraft of Question 5 at an altitude of 20,000 feet?
7. What is the effect of increasing the normal acceleration load factor on the drag equation?
8. Can an F-14 "turn inside" a P-3 if both are at the same air speed and the same angle of bank? Why?
9. Given $V_p/V_S = 2.65$ and $V_{MAX}/V_S = 5.5$, draw the positive load factor portion of the V-n diagram for an aircraft whose stall speed is 100 knots.

PERFORMANCE II

Unit 5

STUDY QUESTIONS - SOLUTIONS

1. Level 100% Lift

$$\phi = 30^\circ \quad 115\% \quad 15\% \text{ increase}$$

$$\phi = 45^\circ \quad 141\% \quad 41\% \text{ increase}$$

$$\phi = 60^\circ \quad 200\% \quad 100\% \text{ increase}$$

2. Aerodynamic Limit

3. Structural limit

- 4.
- n
- is proportional to
- V^2
- Varies as
- V^2

$$5. V_s = \left(\frac{2W}{\rho S C_{L_{\max}}} \right)^{\frac{1}{2}} = 195.6 \text{ ft/sec} = 115.8 \text{ kts}$$

$$V_p = V_s \sqrt{n} = 327.5 \text{ kts}$$

6. at 20,000 ft,
- $V_{ep} = 327.5 \text{ kts}$
- (same as at sea level)

$$7. C_D = C_{D_o} + C_{D_i} = C_{D_o} + C_L / \pi AR e$$

$$C_L = 2nW / (\rho S V^2)$$

$$C_L^2 = f(n^2)$$

therefore C_{D_i} increases as n^2

8. No Both are at same
- V
- and same
- ϕ

$$\text{Radius of turn} = \frac{V^2}{g} \frac{1}{\tan \phi}$$

$$9. \text{ If } V_p/V_s = 2.65 = \sqrt{n}$$

$$n = 7$$

$$V_p = 2.65 \times 100 = 265 \text{ kts}$$

$$V_{\max} = 5.5 \times 100 = 550 \text{ kts}$$

Unit 5-A

Maneuvering Performance

5A-1. INTRODUCTION

When the airplane is in turning flight, the airplane is not in static equilibrium for there must be developed the unbalance of force to produce the acceleration of the turn. During a steady coordinated turn, the lift is inclined to produce a horizontal component of force to equal the centrifugal force of the turn. In addition, the steady turn is achieved by producing a vertical component of lift which is equal to the weight of the airplane. Figure 5A-1 illustrates the forces which act on the airplane in a steady, coordinated turn.

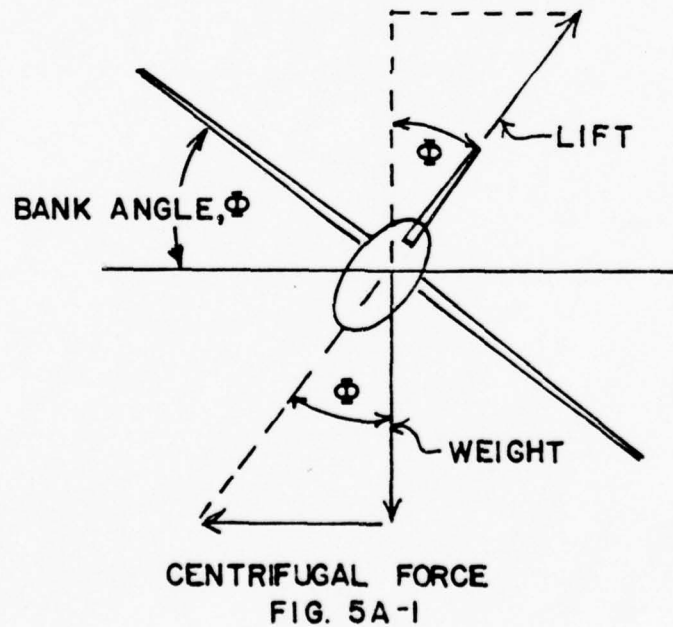

For the case of the steady, coordinated turn, the vertical component of lift must equal the weight of the aircraft so that there will be no acceleration in the vertical direction. This requirement leads to the following relationship:

$$n = \frac{L_T}{W} \quad (1)$$

$$n = \frac{1}{\cos \phi} = \sec \phi \quad (2)$$

where

n = load factor or "G"

L_T = lift, lbs.

W = weight, lbs.

ϕ = bank angle, degrees

From this relationship, it is apparent that the steady, coordinated turn requires specific values of load factor, n , at various angles of bank, ϕ . For example, a bank angle of 60° requires a load factor of 2.0 ($\cos 60^\circ = 0.5$ or $\sec 60^\circ = 2.0$) to provide the steady, coordinated turn. If the airplane were at a 60° bank and lift were not provided to produce the exact load vector of 2.0, the aircraft would be accelerating in the vertical direction as well as the horizontal direction and the turn would not be steady. Also, any sideforce on the aircraft due to sideslip, etc., would place the resultant aerodynamic force out of the plane of symmetry perpendicular to the lateral axis and the turn would not be coordinated.

As a consequence of the increase lift required to produce the steady turn in a bank, the induced drag is increased above that incurred by steady, wing level, lift-equal-weight flight. In a sense, the increased lift

required in a steady turn will increase the total drag or power required in the same manner as increased gross weight in level flight. The curves of figure 5A-2 illustrate the general effect of turning flight on the total thrust and power required. Of course, the change in thrust required at any given speed is due to the change in induced drag and the magnitude of change depends on the value of induced drag in level flight and the angle of bank in turning flight.

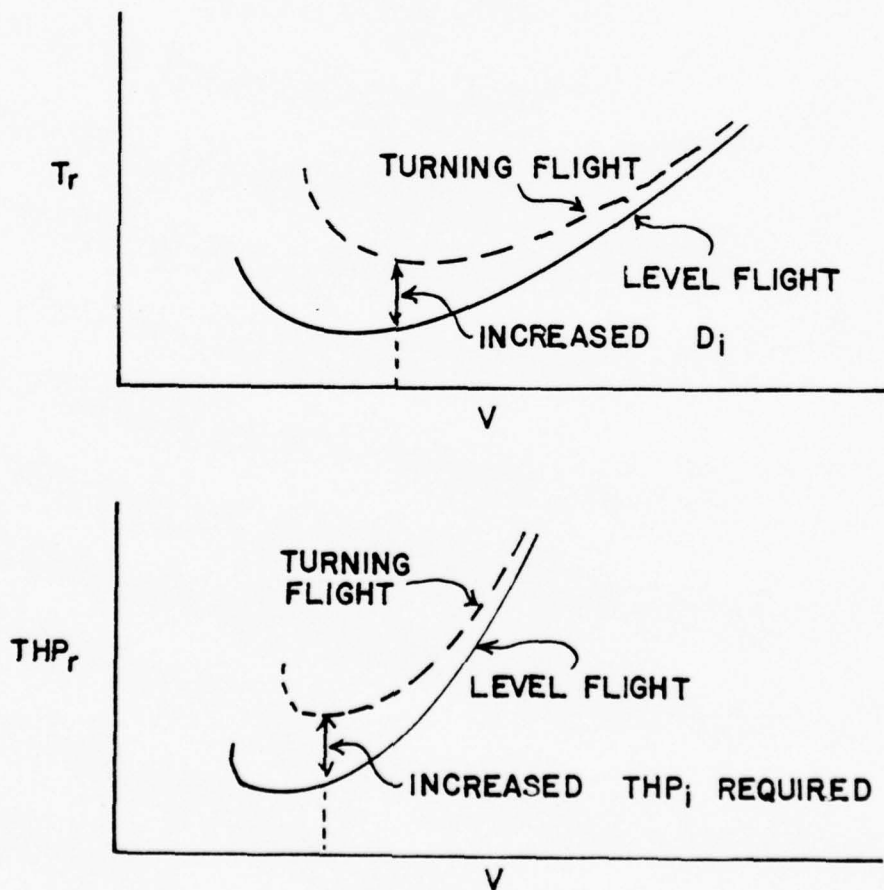

FIG. 5A-2

Since the induced drag predominates at low speeds, steep turns at low speeds, can produce significant increases in thrust or power required to maintain altitude. Thus, steep turns must be avoided after takeoff, during approach, and especially during a critical power situation from failure or malfunction of a powerplant. The greatly increased induced drag is just as important - if not more important - as the increased stall speed in turning flight. It is important also that any turn be well coordinated to prevent the increased drag attendant to a sideslip.

5A-2. TURN RADIUS AND TURN RATE EQUATIONS

In the following section equations will be developed that will permit computation of turn radius and turn rate from variables that can be measured in flight (bank angle or load factor and airspeed).

The total lift forces acting on the aircraft in a level turn are shown in Figure 5A-3.

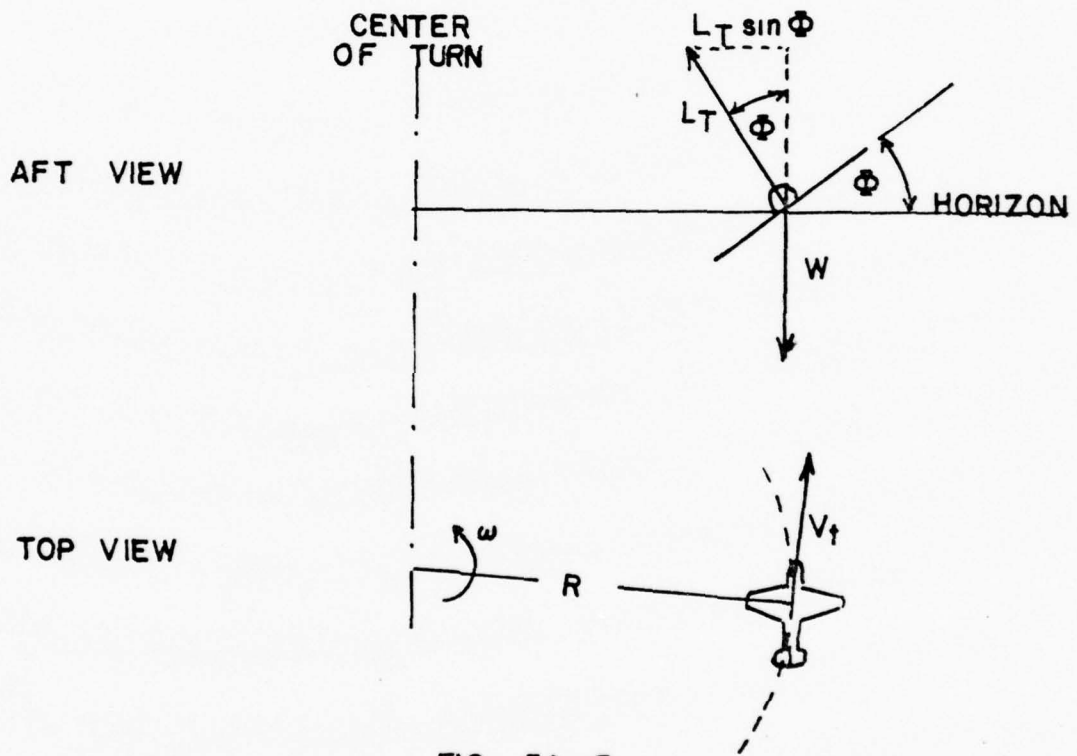

FIG. 5A-3

Note that in the above diagrams it is assumed that the total lift vector is tilted through the same angle (ϕ) as the airplane is banked (i.e., L_T is normal to the airplane's y axis). Thus there is no side force acting on the airplane.

Since the airplane is in a level turn we can state

$$\Sigma F_v = 0$$

which gives

$$L_T \cos \phi = W$$

$$\cos \phi = \frac{W}{L_T} \quad (3)$$

The force in the radial direction causes the aircraft to accelerate radially, thus

$$\Sigma F_R = M a_r \quad \text{Where } F_R = \text{Forces in radial direction} \quad (4)$$

a_r = Corresponding acceleration in radial direction. From mechanics we have that

$$a_r = \frac{V^2}{R}$$

Evaluating the (ΣF_R) term (see the above figures):

$$L_T \sin \phi = \frac{W}{g} a_r \quad (5)$$

Substituting $\frac{V^2}{R}$ for a_r and rearranging gives

$$R = \frac{V^2}{g} \frac{W}{L_T} \frac{1}{\sin \phi} \quad (6)$$

Substituting Equation 3 for (W/L_T) gives

$$R = \frac{V^2}{g} \frac{\cos \phi}{\sin \phi} \quad (7)$$

or

$$R = \frac{V^2}{g} \frac{1}{\tan \phi} \quad (8)$$

The above equation allows the use of the true airspeed (V_t) and the bank angle (ϕ) obtained in a level turn to compute a corresponding turn radius (r).

The turn radius in a level turn can also be computed given the airspeed and load factor (η_z). From Equation 3:

$$\frac{L_T}{W} = \frac{1}{\cos \phi} \quad (9)$$

but since $\frac{L_T}{W} = \eta_z$ then

$$\eta_z = \frac{1}{\cos \phi} \quad (10)$$

The above assumes that the accelerometer reading η_z is consistent with the orientation of the L_T vector. That is

a. Normal to the flight path

and

b. Normal to the airplane y axis.

Thus it can be seen that the load vector varies inversely as the cosine of the bank angle. It should be noted here that the load factor η_z is not what the pilot reads off the accelerometer which is aligned with a body axis of the airplane. For simplicity, it is assumed that it is aligned with the chord line from which the true angle of attack is measured.

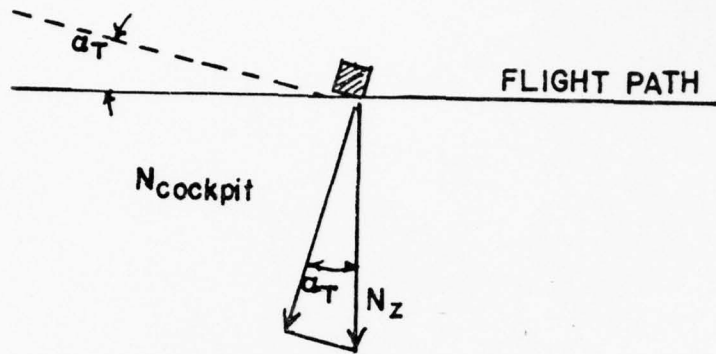

FIG. 5A-4

Then: $\cos \alpha_T = \frac{N_{cockpit}}{n_z}$

$n_{cockpit} = n_z \cos \alpha_T$

but $n_z = \frac{1}{\cos \phi}$

therefore $n_{cockpit} = \frac{\cos \alpha_T}{\cos \phi}$

Equations 8 and 10 can now be combined and arranged using the identity $\left(\frac{1}{\cos \phi}\right)^2 = \sec^2 \phi = 1 + \tan^2 \phi$ to give the following

$$R = \frac{V^2}{g (n_z^2 - 1)^{1/2}} \quad (11)$$

This equation can now be used to compute the turn radius, given the true airspeed and load factor.

An equation for turn rate can be determined from the turn radius equation

$$V = \omega R \quad (12)$$

Where V = true airspeed (f_{ps}) (12)

ω = turn rate (rad/sec)

(See Figure 5A-3)

R = turn radius - ft

Solving Equation 12 for ω gives

$$\omega = \frac{V}{R}$$

and substituting Equation 11 into the above gives

$$\omega = \frac{g}{V} (\eta_z^2 - 1)^{1/2} \quad (13)$$

or substituting Equation 8 into Equation 12 gives

$$\omega = \frac{g}{v} \tan \phi \quad (14)$$

5A-3. MANEUVERING PERFORMANCE TESTING

One of the most difficult areas in performance testing today is to present useful data which can be used to compare one airplane against another while in maneuvering flight. The various factors which make this so difficult are these:

- (1) Maneuvering flight can take place in three dimensions while accelerating or decelerating along the flight path.
- (2) It is affected by aerodynamic consideration, engine performance and structural limitations. (discussed later in this Section and Section 5-C.)
- (3) The individual pilot technique used in maneuvering the airplane makes it difficult to get repeatable data from different pilots.

The necessary standardized data are gathered from flight tests and are used in conjunction with equations (11) and (13) to make plots of load factor (n), radius of turn and rate of turn versus true airspeed or Mach number. Actual flight test results for the T38A aircraft are shown in Figure 5A-5. It should be noted that the minimum radius of turn airspeed is not necessarily the airspeed for maximum rate of turn.

There are three factors which will influence the characteristics of these curves. They are the aerodynamic characteristics, the power characteristics and the structural limitations of the particular airplane. The aerodynamic and power factors are inter-related through the lift and drag characteristics of the particular airplane. If neither of these factors are limiting then the curves will be limited by the structural characteristics of the airplane. These characteristics will be discussed in more detail in Section 5-C.

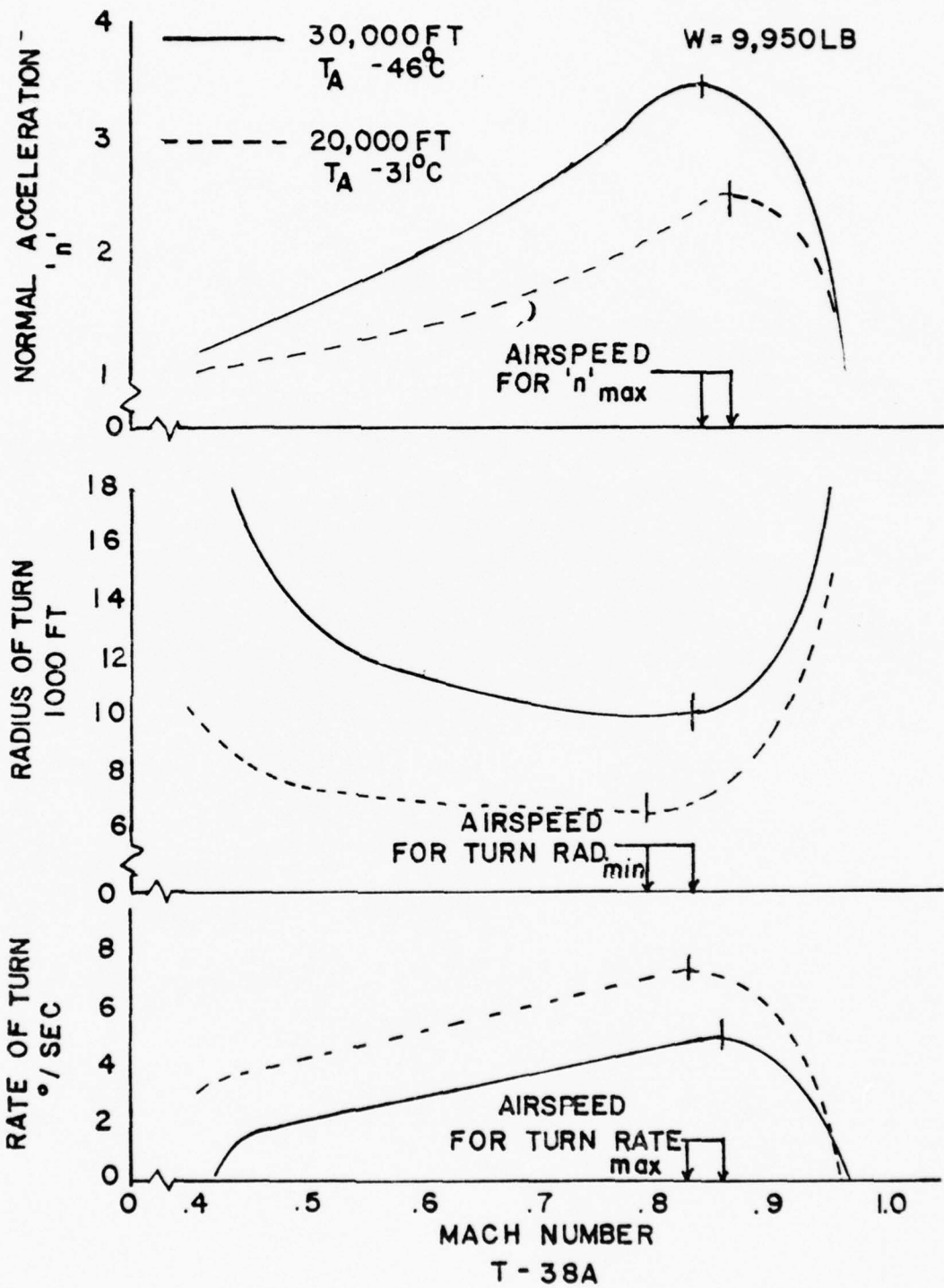

FIG. 5A-5

PROBLEMS

1. Given an airplane in a level turn and

$$KTAS = 300$$

$$\eta_z = 3$$

- Find - a. Turn radius (R) in feet.
b. Turn rate in deg/sec.

2. An accelerometer is installed in an airplane with its sensitive axis oriented as follows:

- a. Normal to flight path (when $\alpha = 10''$) and
b. Normal to the airplane's y axis.

Assume that the only errors involved are due to the difference between the orientation of actual accelerometer and the "ideal" accelerometer in the derivation of Equation . How would the true turn radius compare to the computed turn radius?

- a. Skidding turn ($\alpha_T = 10^\circ$)
b. Slipping turn ($\alpha_T = 10^\circ$)
c. Normal turn (no side force) but $\alpha_T \neq 10^\circ$.

3. Assume that bank angle ϕ can be measured to within $\pm 1^\circ$ (.99) of the true ϕ and that η_z can be measured to within $\pm .1g$ (.99) of the true η_z .

Discuss which variable (ϕ or η_z) should be used to minimize the error in the computed turn radius.

UNIT 5B

INSTANTANEOUS MANEUVERABILITY

5B-1 PULL-UPS

The load factor (n_z) can be expressed as before:

$$n_z = \frac{L_T}{W}$$

Where n_z is the load factor (1) measured normal to the flight path and

L_T is the total lift on the airplane (also measured normal to the flight path)

Note that the above expression is valid for any aircraft attitude (inverted, nose up or nose down attitude, etc.)

The total lift (L_T) is made up of the aerodynamic lift (L_{aero}) and the gross thrust lift (L_g).

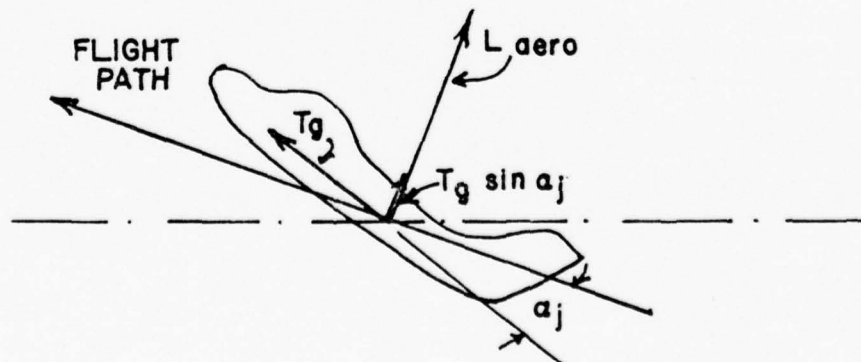

FIG. 5B-1

Thus we have

$$L_T = L_{\text{aero}} + L_g \quad (2)$$

$$L_T = L_{\text{aero}} + T_g \sin \alpha_j$$

or since

$$L_{\text{aero}} = C_L q S,$$

$$L_T = C_L q S + T_g \sin \alpha_j \quad (3)$$

Substituting the above equation into Equation (1) and expressing q as a function of Mach gives

$$n_z = \underbrace{\frac{\gamma}{2} \frac{P_a C_L M^2}{W/S}}_{\text{Aerodynamic Lift}} + \underbrace{\frac{T_g}{W} \sin \alpha_j}_{\text{Thrust Lift}} \quad (4)$$

If we assume for the moment that the thrust lift is much smaller than the aerodynamic lift, then the above equation can be written as

$$n_z = \frac{\gamma}{2} \frac{P_a C_L M^2}{W/S} \quad (5)$$

The above equation illustrates that the load factor is dependent on the following parameters

$$n_z = f(h_p, M, C_L, W/S)$$

5B-2 General Discussion and Trends

The above equation shows that for a given flight condition (h_p and M) the parameters that determine the maximum load factor ($n_{z_{\max}}$) are

- a. $C_{L_{\max}}$
- b. W/S - wing loading

Thus we see that for a given Mach number the designer can provide good instantaneous turning performance ($n_{z_{\max}}$) by providing a high $C_{L_{\max}}$ and/or low wing loading (W/S).

The peak of the C_L vs α curve is normally thought of as the $C_{L_{\max}}$ point, however there are other factors which sometimes cause the useable $C_{L_{\max}}$ to be less than the peak. They are

- ° Insufficient aft control to "fly" the airplane at $C_{L_{\max}}$
- ° Severe buffet and/or degraded flying qualities at high angle of attack

The $n_{z_{\max}}$ equation for a given $C_{L_{\max}}$, wing loading and altitude, simplified to

$$n_{z_{\max}} = K M^2 \quad (6)$$

where

$$K = \left[\frac{\gamma}{2} \frac{C_{L_{\max}}}{W/S} P_a \right]$$

A sketch of the above equations gives (solid line)

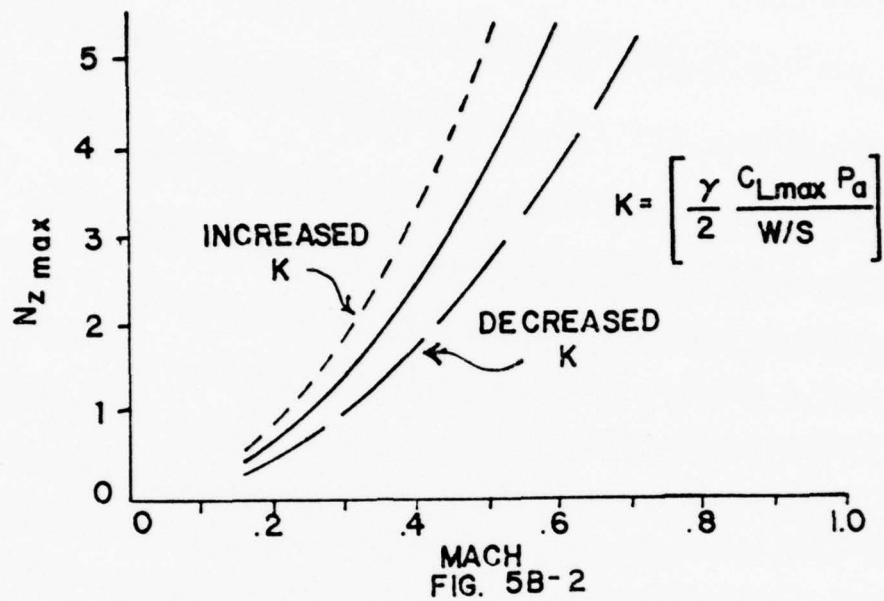

We see that variations in $C_{L\max}$, W/S or pressure altitude simply changes the constant and alters the curve as indicated (dashed lines).

In the discussions above, we have assumed $C_{L\max}$ to be independent of Mach. Actually $C_{L\max}$ is a function of Mach and is illustrated below,

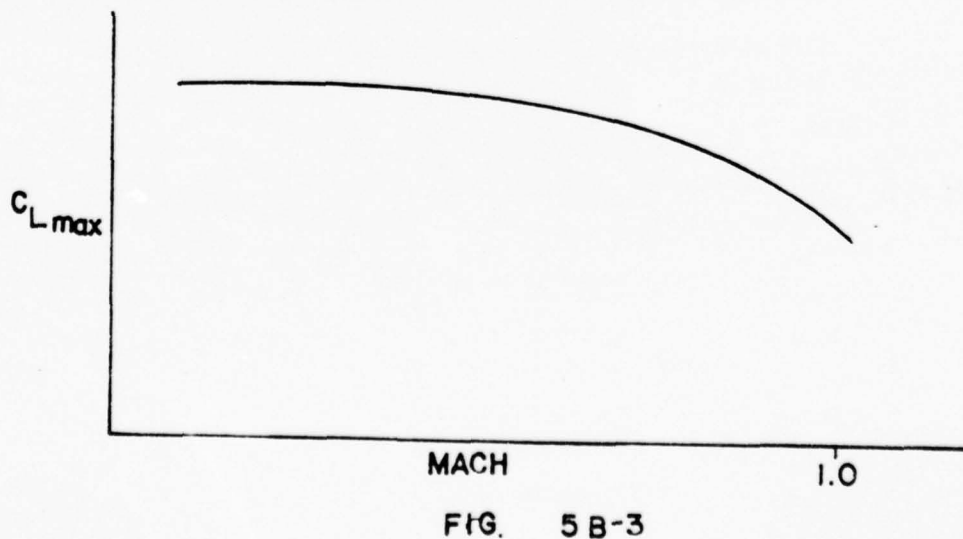

The $C_{L_{\max}} = f(M)$ curve is typically constant in the low Mach range $M < .7$ and then varies in the transonic range. Figures 5B-3 show a typical $C_{L_{\max}}$ for an airplane with thick wing section.

5B-3 Vectored Thrust

So far the "thrust lift" term of the equation has been neglected. This is probably a valid assumption for low thrust settings and/or low thrust line angle of attack (α_j) but obviously can be in error for operation at high thrust/ α_j . The sketch below illustrates the thrust effect for a thrust to weight ratio (T_g/W) of one and $\alpha_j = 90^\circ$ (similar to a Harrier with nozzles deflected).

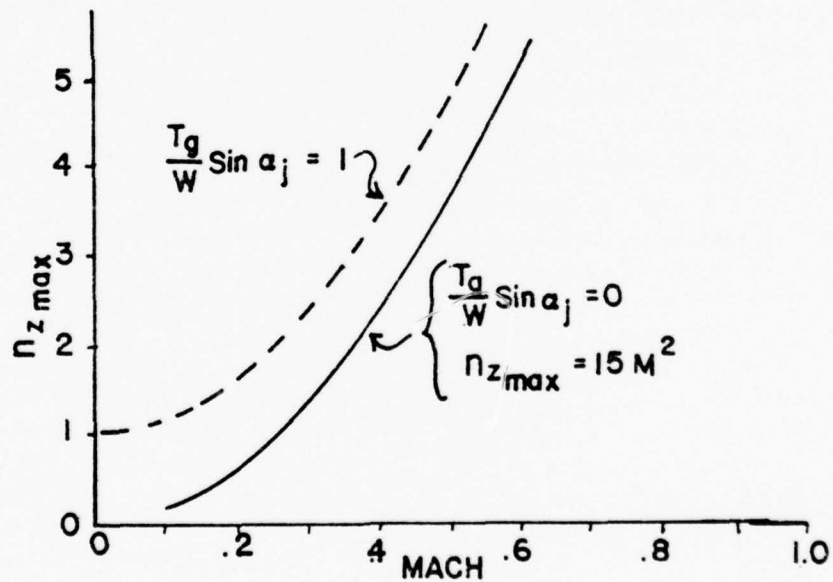

FIG. 5B-4

$$n_z = K M^2 + \frac{T}{W} \sin \alpha_j \quad (7)$$

where

$$K = \frac{\gamma}{2} P_a M^2 \frac{C_{L_{\max}}}{W/S}$$

Figures 5B-5 and 5B-6 illustrate the effects of "vectored thrust" case on the turn radius (r) and rate (ω). (The level turn equation was used to convert the load factor/velocity variations to turn radius and rate.) Examining the results we see that in general the largest gain in performance (turn rate and radius) occur at the lowest speeds. An alternate method of obtaining improved turning performance (Δn_z) would be to increase the useable $C_{L_{\max}}$ of the airplane. The effectiveness of an increase in $C_{L_{\max}}$ on the $n_{z_{\max}}$ is shown below

$$\Delta n_{z_{\max}} = \frac{\Delta C_L}{W/S} q \quad (8)$$

We see that the "effectiveness" of a C_L increase (ΔC_L) to produce an increase in maneuvering performance ($\Delta n_{z_{\max}}$) is determined by the term $q/W/S$. Thus at high q (airspeed) and for low wing loadings (W/S) a given change in $C_{L_{\max}}$ will be very effective in producing an increased load factor capability ($\Delta n_{z_{\max}}$). Conversely at low q and high wing loading a given increase in $C_{L_{\max}}$ is not too effective in increasing the load factor. (See problem 3.c)

It is important to realize that in the above analysis only one aspect of turning performance (max load factor) has been considered. Obviously as thrust is deflected to get more lift the thrust component along the flight path will be decreased which will cause high deceleration and/or rate of descent. This second aspect (Energy Rate) will be considered later.

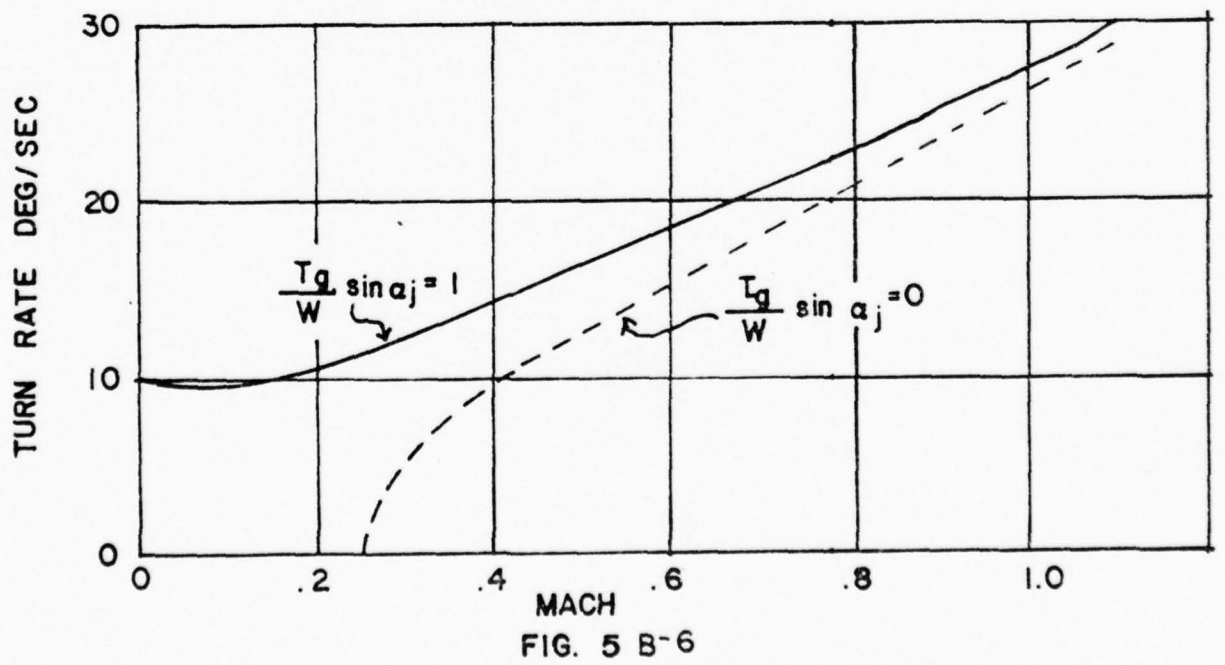
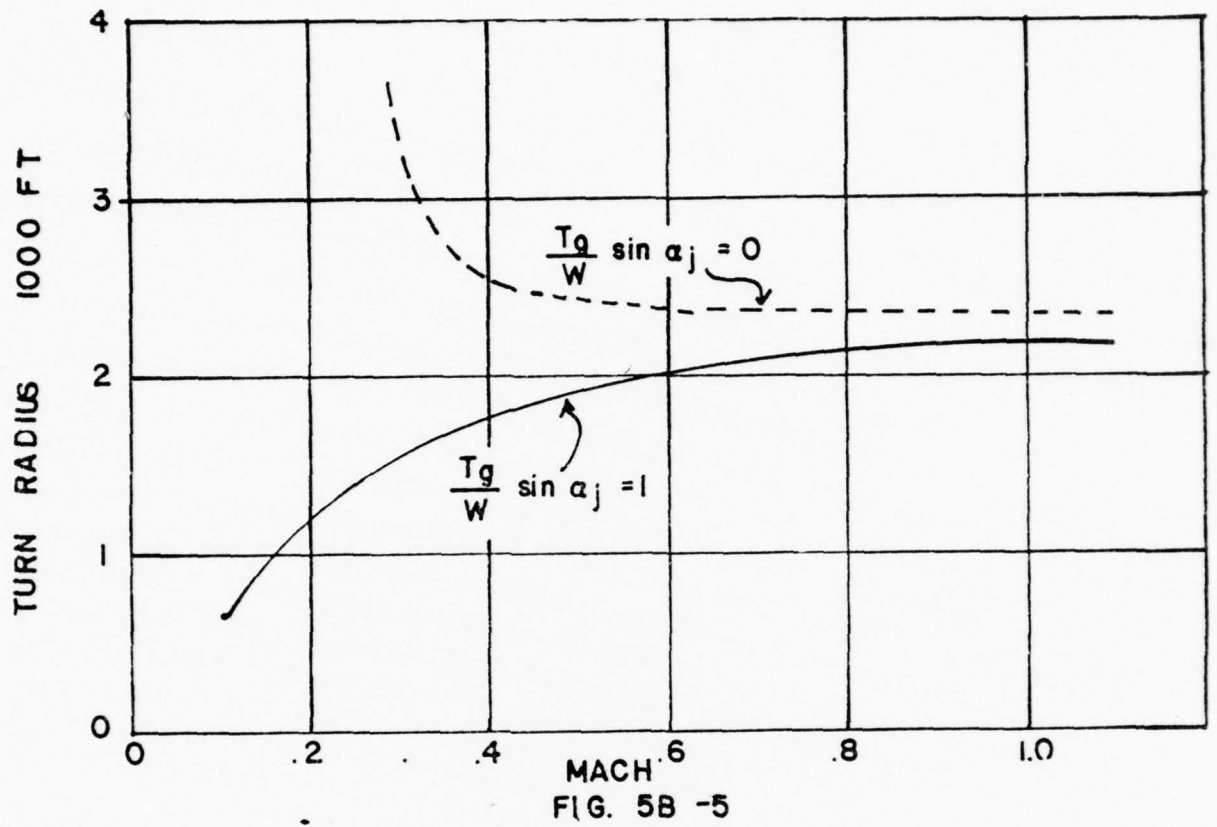

Problems

1. How much of an improvement (percent increase or decrease) in $n_{z_{\max}}$ would you expect for
- a 10% decrease in gross weight
 - increasing Mach from .4 to .6
 - increasing pressure altitude from 5000 to 23,000 ft
 - increasing $C_{L_{\max}}$ by 10%

2. Given an airplane at the following test conditions

$$M_t = .7$$

$$S = 200 \text{ ft}^2$$

$$h_{pt} = 12,000 \text{ ft}$$

$$T_{a_t} = 12^\circ\text{C}$$

$$W_t = 12,000 \text{ lbs}$$

$$n_{z_{\max}} = \left[6 n_{z_{\max}} \text{ dictated by "excessive" wing rock} \right]$$

- Estimate $C_{L_{\max}}$
- Estimate the $n_{z_{\max}}$ for the same degree of wing rock for
 - same Mach and pressure altitude but for standard day conditions ($W_s = 10,000 \text{ lb}$, $T_{a_s} = -9^\circ\text{C}$)
 - same Mach but for standard day conditions at $h_p = 15,000 \text{ ft}$ ($W_s = 10,000 \text{ lb}$)
 - $M = .85$, $h_p = 15,000$, $T_a = -17^\circ\text{C}$, $W_s = 10,000 \text{ lb}$

- c. List the assumptions involved in making the estimates in 2(a), 2(b) and discuss limitations of these assumptions.
- d. Assume $n_{z_{\max}}$ in the test was defined by full aft stick vice wing rock. Discuss additional limitations (assumptions) involved in making the estimate of parts 2(a) and 2(b).

3. Given an airplane with the following characteristics

$$C_{L_{\max}} = 1.0$$

$$W = 12,000 \text{ lb}$$

$$S = 200 \text{ ft}^2$$

$$T_g = 10,000 \text{ lb}$$

$$\alpha_j = 0^\circ$$

$$T_a = -5^\circ\text{C}$$

- a. What is the $n_{z_{\max}}$ at $M = .6$ and $h_p = 10,000 \text{ ft}$?
- b. Estimate the instantaneous level turn rate and radius?
- c. What is the $n_{z_{\max}}$ and corresponding turn rate and radius when the α_j is increased to 90° ?
- d. How much would $C_{L_{\max}}$ have to be increased to get the same "numbers" as obtained in part (c)?
- e. What are some other considerations involved in deciding which method (vectored thrust or $C_{L_{\max}}$ increase) to use to increase instantaneous maneuvering performance.

4. Shown that for the $C_{L_{\max}}$ boundary

Assume:

$$n_z = KM^2 \quad \text{Case 1}$$

$$n_z = KM^2 + 1 \quad \text{Case 2 (vectored thrust - } \frac{T}{W} \sin \alpha_j = 1)$$

$$\text{a. } \lim_{M \rightarrow \infty} R = \frac{V^2}{gK} \quad \text{for Case 1 and 2}$$

and

$$\text{b. } \lim_{M \rightarrow \infty} \left(\frac{\omega}{M}\right) = \frac{gK}{V} 57.3 \quad \text{for Case 1 and 2}$$

and

$$\text{c. } \lim_{M \rightarrow 0} \omega = \frac{57.3 \sqrt{2} K^{1/2}}{V_a} \quad \text{for Case 2}$$

where

$$K = \frac{C_{L_{\max}} \gamma P_a}{2 [W/S]}$$

- d. Compare the above results with Figures 5B-5 and 5B-6. ($K = 15$ for Figures 5B-5 and 5B-6.)

ANSWERS

1.a. $(.9)^{-1}$ or +11% Change

1.b. $(.6/.4)^2$ or +125% Change

1.c. $\delta_{23K}/\delta_{5K} = 1/2$ or -50% Change

1.d. 1.1 or +10% Change

2.a. $C_{L_{max}} = .780$

2.b.(1) $n_{z_{max}} = 7.2$

2.b.(2) $n_{z_{max}} = 6.389$

2.b.(3) $n_{z_{max}} = 9.421$

2.c. 2.a → no thrust lift

2.b.(1) → $C_{L_{max}} = c$, no thrust lift

2.b.(2) → $C_{L_{max}} =$ (no R_n effect) No thrust lift

2.b.(3) $C_{L_{max}} =$ (no R_n effect, no M effect) No thrust lift

3.a. 6.112

3.b. $\omega = 17.2$ °/sec

$R = 2150$ ft

3.c. $n_z = 6.945$

$W = 19.6$ °/sec

$R = 1886$ ft

3.d. $\Delta C_{L_{max}} = .1363$

4. The derivation of (a) follows:

$$R = \frac{V^2}{g(n^2 - 1)^{1/2}} \text{ (ft)}$$

and

$$n_z = K M^2 \text{ for Case 1}$$

and

$$n_z = K M^2 + 1 \text{ for Case 2}$$

additionally,

$$V = V_a M$$

Thus substituting the expression for n_z and V into the R equation gives

$$R = \frac{V_a^2 M^2}{g(K^2 M^4 - 1)^{1/2}}$$

and taking the limit of R as $M \rightarrow \infty$ gives

$$\lim_{M \rightarrow \infty} R = \frac{V_a^2}{gK}$$

5B-4 SUSTAINED TURNING PERFORMANCE

Consider now the sustained turning performance of the airplane. The main objectives of the investigation is to determine what the typical sustained turning performance boundary looks like and how it changes with various factors.

DEVELOPMENT OF EQUATIONS

Consider the airplane in an "almost" level turn. The forces acting on the airplane as viewed from the center of the turn and at the same altitude are illustrated below

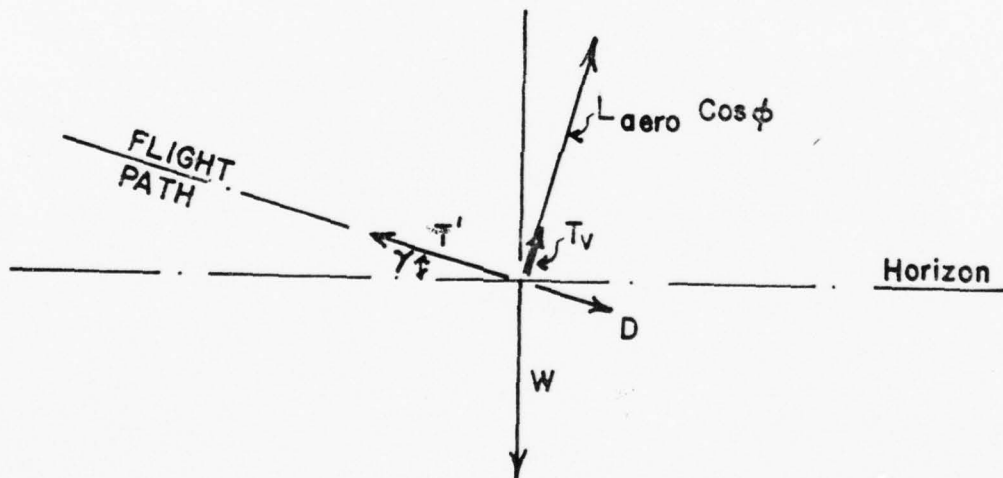

FIG. 5B-7

If the configuration weight and altitude of the airplane are fixed and additionally the "low speed" assumption is made, the above drag equation can be expressed as follows

$$D = K_1 V_T^2 + K_2 \eta_z^2 V_T^{-2} \quad (13)$$

Where T' is the thrust component along the flight path and is

$$T' = T_g \cos \alpha_j - T_R$$

And T'_v is the thrust component along the lift axis (as viewed from the center of the turn) and is

$$T'_v = [T_g \sin \alpha_j] \cos \phi$$

Summing the forces along the flight path gives

$$\Sigma F_{fp} = \frac{W}{g} \frac{dv}{dt} \quad \text{assumes } v \frac{dm}{dt} \ll m \frac{dv}{dt}$$

$$T' - D - W \sin \gamma = \frac{W}{g} \frac{dv}{dt} \quad (9)$$

The flight path angle (γ) is related to dh/dt and v as indicated below

$$\sin \gamma = \frac{dh/dt}{v}$$

Substituting the above into Equation (9) and simplifying gives

$$\frac{T' - D}{W} = \frac{dv/dt}{g} + \frac{dh/dt}{v} \quad (10)$$

For the ideal sustained level turn

$$\left. \begin{array}{l} \frac{dv}{dt} = 0 \\ \text{and} \\ \frac{dh}{dt} = 0 \end{array} \right\} *$$

NOTE: Later the dv/dt and dh/dt terms will be picked up to illustrate the effect of non-stabiliza-

$\left(\frac{dv}{dt} \neq 0, dh/dt \neq 0 \right)$ on the flight

test data.

*A more general definition of a sustained term $dE_h/dt = 0$

and thus the required conditions for the sustained turn are

$$\frac{T' - D}{W} = 0 \quad (11)$$

or simply

$$T' = D$$

We are normally interested in the maximum turning capability of the airplane thus T' is based on the full thrust case (either IRT or MRT). The objective now is to see how tightly the airplane can turn [what η_z level can be obtained] for a given set of conditions. In order to do this we must determine how the drag (D) varied with η_z .

5B-5 SUSTAINED TURN PERFORMANCE (PARABOLIC DRAG POLAR)

If we assume a parabolic drag polar the drag equation becomes

$$D = C_{DO} q s + \frac{(L_T - T_g \sin \alpha_j)^2}{\pi e A R s q} \quad (12)$$

where $L_T - T_g \sin \alpha_j = L_{aero}$

substituting [$L_T = \eta_{zw}$] into Equation (12) gives

$$D = C_{DO} q s + \left(\frac{\eta_{zw} - T_g \sin \alpha_j}{\pi e A R s q} \right)^2$$

Assuming that the thrust lift is negligible gives

$$D = C_{DO} q s + \left(\frac{\eta_{zw}}{\pi e A R s q} \right)^2 =$$

where

$$K_1 = \frac{C_{DO} \rho_a s}{2}$$

and

$$K_2 = \frac{2W^2}{\pi eAR s \rho_a}$$

Note that the effect of n_z on the drag equation are equivalent to the weight effects on the level flight equation. For example, doubling the load factor at a given weight produces the same drag equation as doubling the weight at the given load factor. Thus the drag equation can be easily sketched using the same rules as developed for weight changes on the level flight drag equation. Figure 5B-8(A) illustrates the effects n_z on the drag equation.

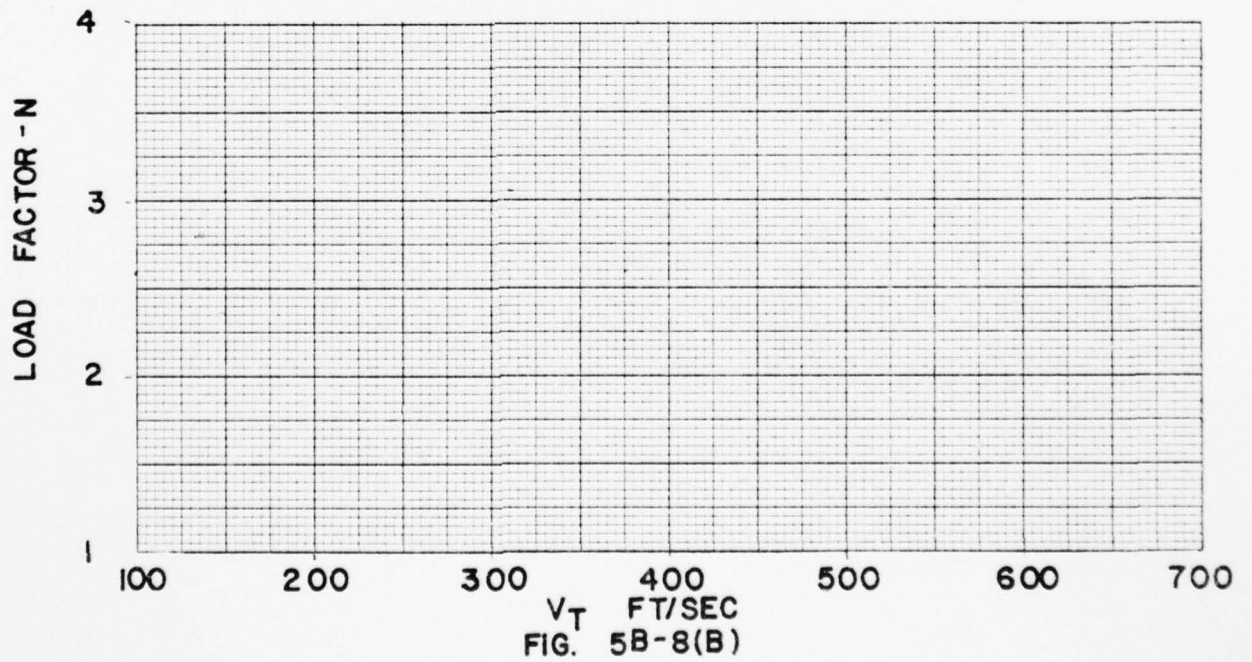
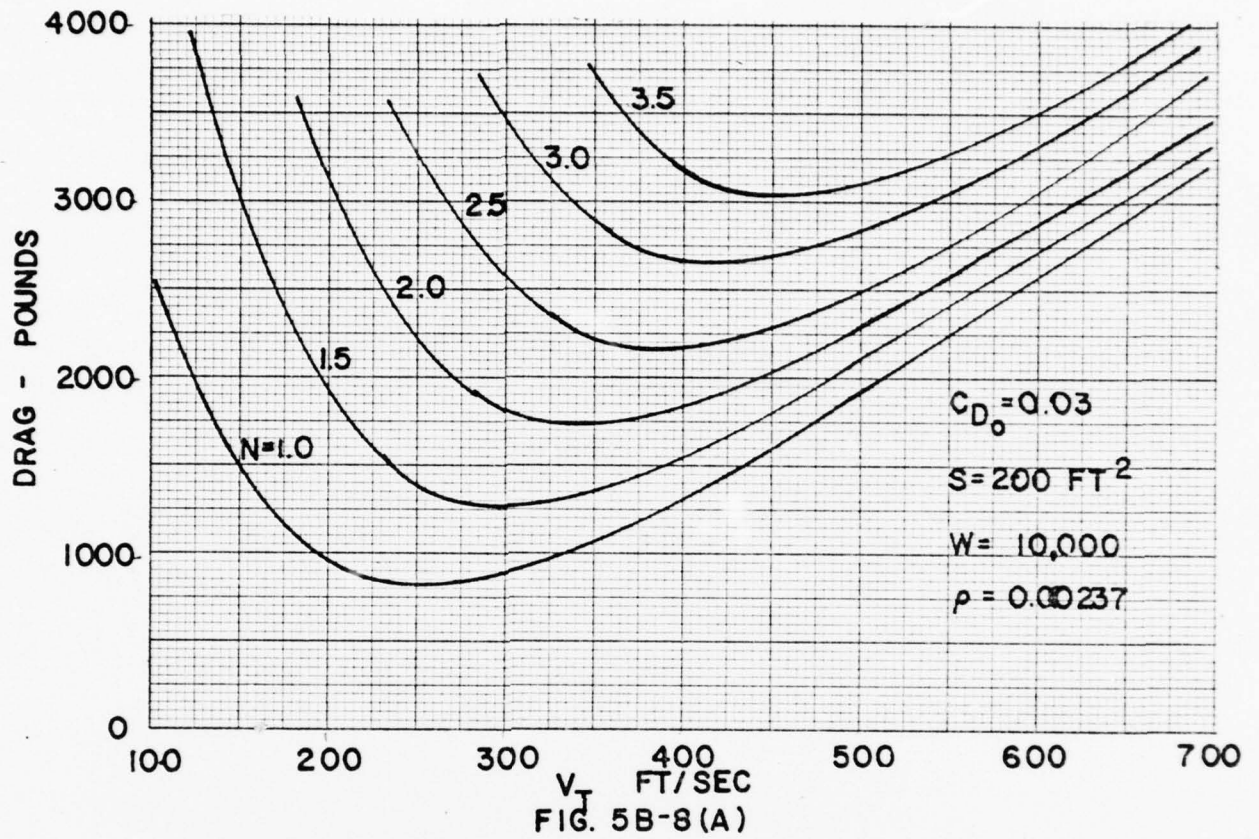

The following problem will illustrate how the sustained turn boundary is related to the airplanes' thrust and drag and lift characteristics.

Given the airplane [Figure 5B-8(A)] delivers 3000 pounds of thrust along the flight path. That is

$$T' = 3000 \text{ lbs}$$

1. Sketch this thrust level on the drag curve [Figure 5B-8]
2. Pick a velocity (say $V_T = 500$ fps) and
3. Estimate how many g's this airplane can pull in level flight ($T' = D$)
4. Plot his η_z on the lower grid [Figure 5B-8(B)]

It should be apparent that for the above example the airplane can sustain ≈ 3.4 g's. Any more g's and the drag would be greater than the thrust and the airplane would descend according to Equation 16.

$$\frac{T' - D}{W} = \frac{dh/dt}{V} \quad \text{Assuming } \frac{dv}{dt} = 0$$

Likewise any less than 3.4 g's and T' would be greater than the D and the airplane would climb.

5. The above problem should be worked for other V_T and the $\eta_z = f(V_T)$ curve sketched. Assume that $C_{L_{\max}}$ is sufficiently high to be out of the picture ($C_{L_{\max}} = \infty$, if you like).

The next task is to illustrate how a $C_{L_{\max}}$ limit would modify the $\eta_z = f(V_T)$ curve.

6. Assume $C_{L_{\max}}$ is represented by the C_{L_1} line shown in Figure 5B-8.

7. Determine corresponding $\eta_z - V_T$ values along the $C_{L_{max}}$ boundary and plot these values on figure 5B-8.

Note that on the portion of the $\eta_z = F(V_T)$ curve where η_z is determined by the $C_{L_{max}}$ limit (dotted line in sketch below) that $T' > D$,

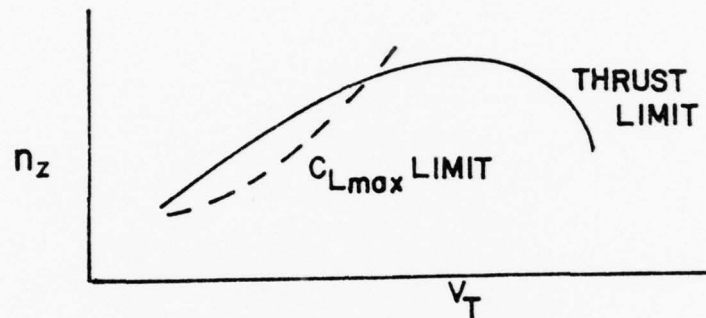

FIG. 5B-9

This means that at full thrust the airplane will climb any given V_T . It also implies that in order to maintain level flight at any given speed along this boundary the engine thrust must be reduced.

The final step is to consider a structural limit. For our example assume $\eta_{z_{max}} = 3$. Sketch this limit on the $\eta_z = f(V_T)$ curve.

We have now developed a relative complete $\eta_z = f(V_T)$ example that illustrates the three common limits ($C_{L_{max}}$, $\eta_{z_{max}}$ and $T' = D$) on the level turn.

PROBLEM

Illustrate how the sustained $\eta_z = f(M)$ curve would vary with

- a. An increase in weight
- b. $C_{D_0} \uparrow$
- c. Increase h_p
- d. $C_{D_0} = f(M)$

UNIT 5C

TACTICAL PERFORMANCE

5C-1 Operating Limits

Many tactical maneuvers require the use of the maximum turning capability of the airplane. The maximum turning capability of an airplane will be defined by three factors:

(1) Maximum lift capability. The combination of maximum lift coefficient, $C_{L_{MAX}}$, and wing loading, W/S , will define the ability of the airplane to develop aerodynamically the load factors of maneuvering flight.

(2) Operating strength limits will define the upper limits of maneuvering load factors which will not damage the primary structure of the airplane. These limits must not be exceeded in normal operations because of the possibility of structural damage or failure.

(3) Thrust or power limits will define the ability of the airplane to turn at constant altitude. The limiting condition would allow increased load factor and induced drag until the drag equals the maximum thrust available from the powerplant. Such a case would produce the maximum turning capability for maintaining constant altitude. The first illustration of figure 5C-1 shows how the aerodynamic and structural limits define the maximum turning performance. The aerodynamic limit describes the minimum turn radius available to the airplane when operated at $C_{L_{MAX}}$. When the airplane is at the stall speed in level flight, all the lift is necessary to sustain the aircraft in flight and none is available to produce a steady turn. Hence, the turn radius at the stall speed is infinite. As speed is increased above the stall

speed, the airplane at $C_{L_{MAX}}$ is able to develop lift greater than weight and produce a finite turn radius. For example, at a speed twice the stall speed, the airplane at $C_{L_{MAX}}$ is able to develop a load factor of four and utilize a bank angle of 75.5° ($\cos 75.5^\circ = 0.25$). Continued increase in speed increases the load factor and bank angle which is available aerodynamically but, because of the increase in velocity and the basic effect on turn radius, the turn radius approaches an absolute minimum value. When $C_{L_{MAX}}$ is unaffected by velocity, the aerodynamic minimum turn radius approaches this absolute value which is a function of $C_{L_{MAX}}$, W/S , and σ . Actually, the one common denominator of aerodynamic turning performance is the wing level stall speed.

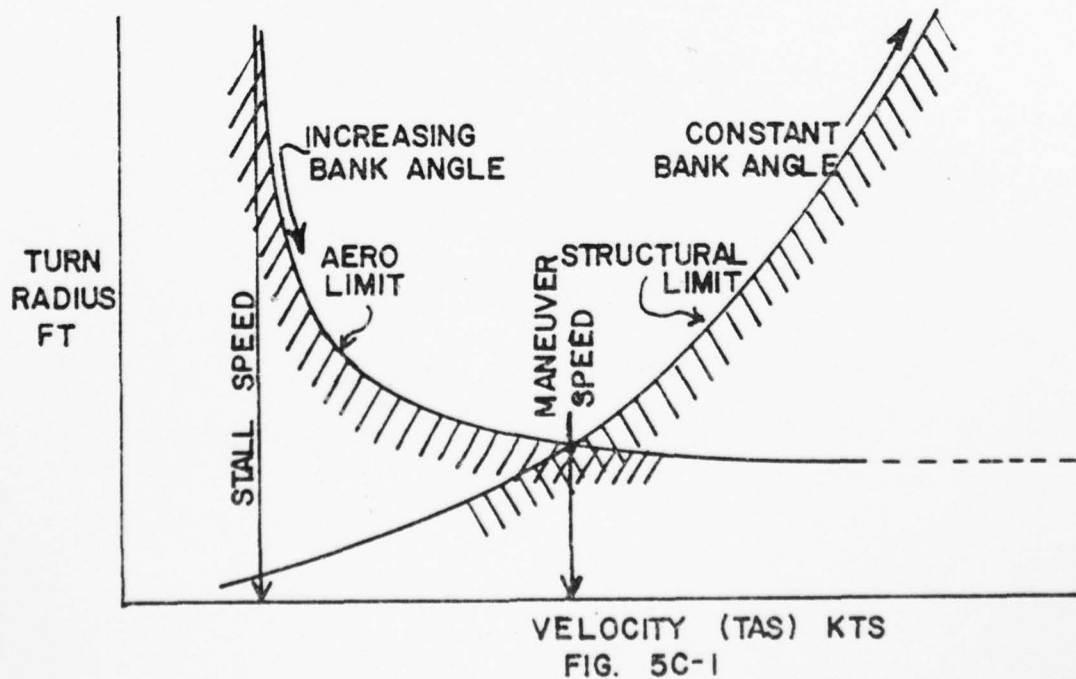

The aerodynamic-limit-of-turn-radius requires that the increased velocity be utilized to produce increasing load factors and greater angles of bank. Obviously, very high speeds will require very high load factors and the absolute aerodynamic minimum turn radius will require an infinite load factor. Increasing speed above the stall speed will eventually produce the limit load factor and continued increase in speed above this point will require that load factor and bank angle be limited to prevent structural damage. When the load factor and bank angle are held constant at the structural limit, the turn radius varies as the square of the velocity and increases rapidly above the aerodynamic limit. The intersection of the aerodynamic limit and structural limit lines is the "maneuver speed". The maneuver speed is the minimum speed necessary to develop aerodynamically the limit load factor and it produces the minimum turn radius within aerodynamic and structural limitations. At speeds less than the maneuver speed, the limit load factor is not available aerodynamically and turning performance is aerodynamically limited. At speeds greater than the maneuver speed, $C_{L_{MAX}}$ and maximum aerodynamic load factor are not available and turning performance is structurally limited. When the stall speed and limit load factor are known for a particular configuration, the maneuver speed is related by the following expression:

$$V_p = V_s \sqrt{n_{limit}} \quad (1)$$

where

V_p = maneuver speed, knots

V_s = stall speed, knots

n_{limit} = limit load factor

For example, an airplane with a limit load factor of 4.0 would have a maneuver speed which is twice the stall speed.

The aerodynamic limit line of the first illustration of figure 5C-1 is typical of an airplane with a $C_{L_{MAX}}$ which is invariant with speed. While this is applicable for the majority of subsonic airplanes, considerable difference would be typical of the transonic or supersonic airplane at altitude. Compressibility effects and changes in longitudinal control power may produce a maximum available C_L which varies with velocity and an aerodynamic turn radius which is not an absolute minimum at the maximum of velocity.

The Figure 5C-2 describes the constant altitude turning performance of an airplane. When an airplane is at high altitude, the turning performance at the high speed end of the flight speed range is more usually thrust limited rather than structurally limited. In flight at constant altitude, the thrust must equal the drag to maintain equilibrium and, thus, the constant altitude turn radius is infinite at the maximum level flight speed. Any bank or turn at maximum level flight speed would incur additional drag and cause the airplane to descend. However, as speed is reduced below the maximum level flight speed, parasite drag reduces and allows increased load factors and bank angles and reduced radius of turn, i.e., decreased parasite drag allows increased induced drag to accommodate turns within the maximum thrust available. Thus, the considerations of constant altitude will increase the minimum turn radius above the aerodynamic limit and define a particular airspeed for minimum turn radius.

Each of the three limiting factors (aerodynamic, structural, and power) may combine to define the turning performance of an airplane. Generally,

AD-A039 654

NAVAL POSTGRADUATE SCHOOL MONTEREY CALIF
A PERSONALIZED SYSTEM OF INSTRUCTION FOR AIRCRAFT PERFORMANCE. (U)
MAR 77 D L FINCH

F/G 5/9

UNCLASSIFIED

NL

4 OF 5
ADA
0 39654



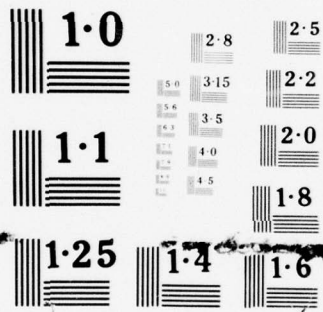

NATIONAL BUREAU OF STANDARDS
MICROCOPY RESOLUTION TEST CHART

aerodynamic and structural limits predominate at low altitude while aerodynamic and power limits predominate at high altitude. The knowledge of this turning performance is particularly necessary for effective operation of fighter and interceptor types of airplanes.

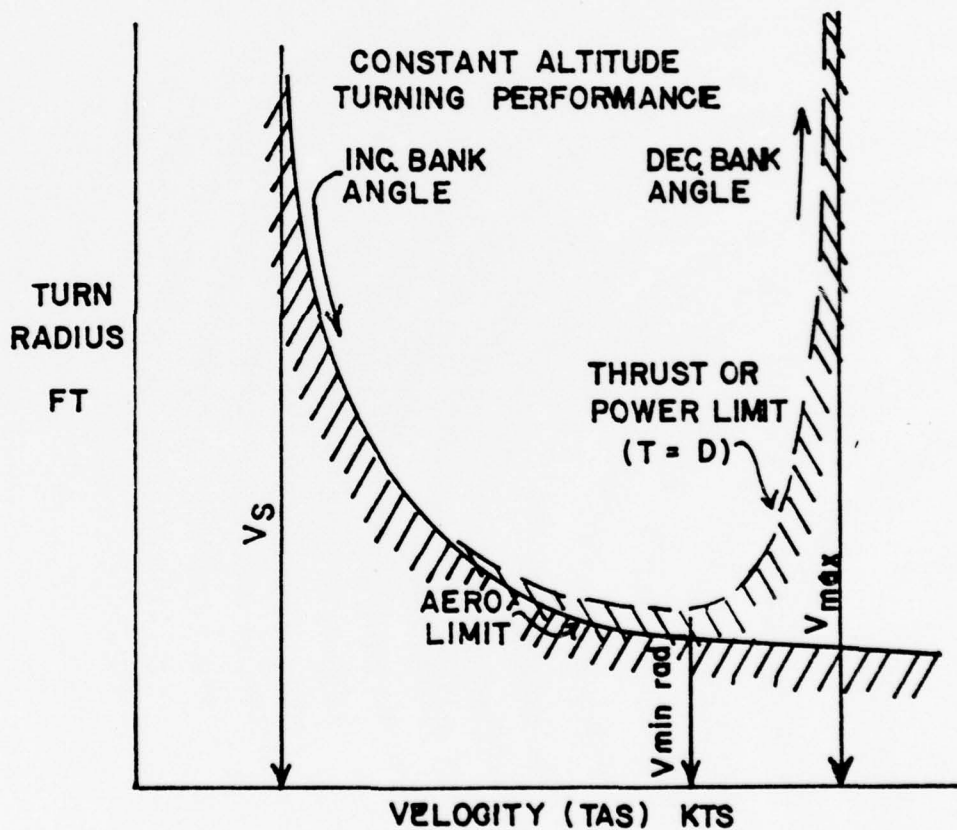

FIG. 5C-2

5C-2 The V-n Diagram

The operating flight strength limitations of an airplane are presented in the form of a V-n diagram. This chart usually is included in the aircraft flight handbook in the section dealing with operating limitations. A typical V-n diagram is shown in figures 5C-3, and is intended to present the most important general features of such a diagram and does not necessarily represent the characteristics of any particular airplane. Each airplane type has its own particular V-n diagram with specific V's and n's.

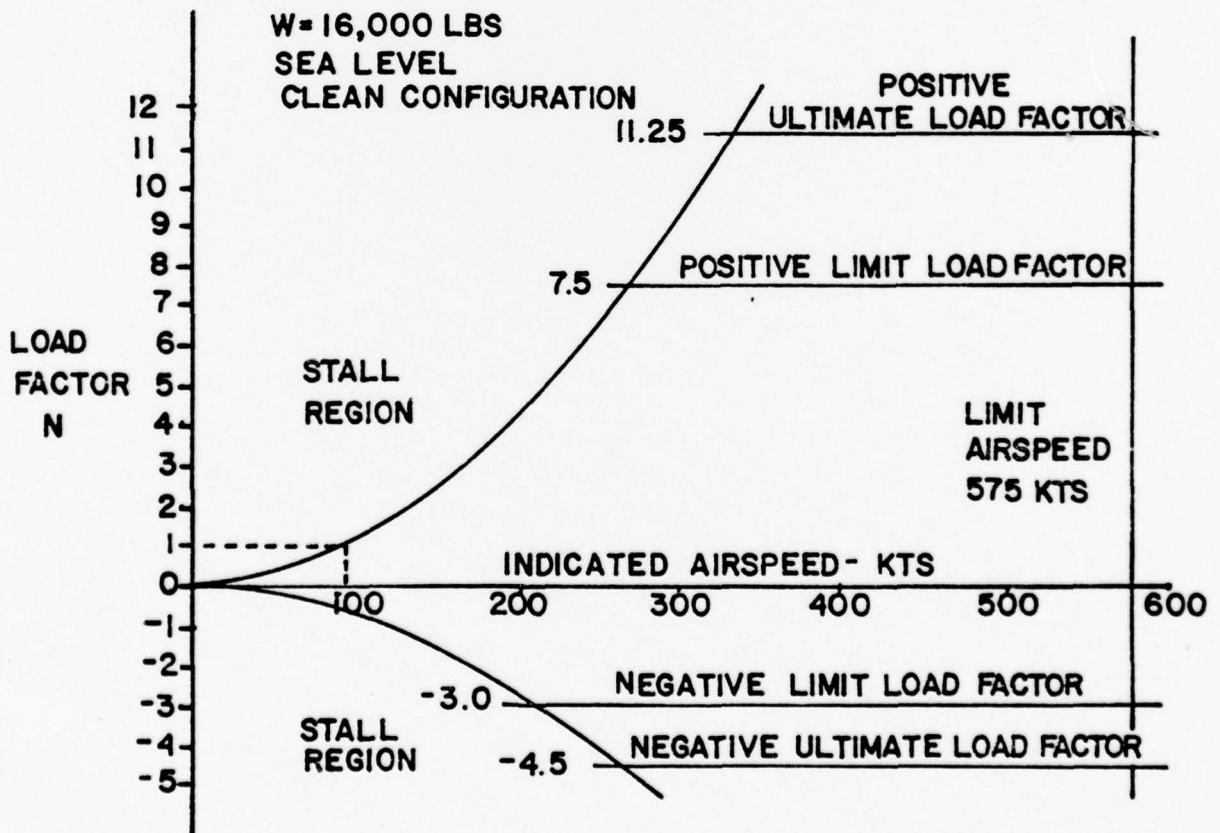

FIG. 5C-3

The flight operating strength of an airplane is presented on a graph whose horizontal scale is airspeed (V) and vertical scale is load factor (n). The presentation of the airplane strength is contingent on four factors being known: (1) the aircraft gross weight, (2) the configuration of the aircraft (clean, external stores, flaps and landing gear position, etc.), (3) symmetry of loading (since a rolling pullout at high speed can reduce the structural limits to approximately two-thirds of the symmetrical load limits) and (4) the applicable altitude. A change in any one of these four factors can cause important changes in operating limits.

For the airplane shown, the positive limit load factor is 7.5 and the positive ultimate load factor is 11.25 (7.5×1.5). The 1.5 factor represents an established standard as stated in military specifications and contract negotiations. For negative lift flight conditions the negative limit load factor is 3.0 and the negative ultimate load factor is 4.5 (3.0×1.5). The limit airspeed is stated as 575 knots while the wing level stall speed is approximately 100 knots.

Figure 5C-4 provides supplementary information to illustrate the significance of the V-n diagram of figure 5C-3. The lines of maximum lift capability are the first points of importance on the V-n diagram. The subject aircraft is capable of developing no more than one positive "g" at 100 knots, the wing level stall speed of the airplane. Since the maximum load factor varies with the square of the airspeed, the maximum positive lift capability of this airplane is 4 "g" at 200 knots, 9 g at 300 knots, 16 g at 400 knots, etc. Any load factor above this line is unavailable aerodynamically, i.e., the subject airplane cannot fly above the line of maximum lift

capability. Essentially the same situation exists for negative lift flight with the exception that the speed necessary to produce a given negative load factor is higher than that to produce the same positive load factor. Generally, the negative $C_{L_{MAX}}$ is less than the positive $C_{L_{MAX}}$ and the airplane may lack sufficient control power to maneuver in this direction.

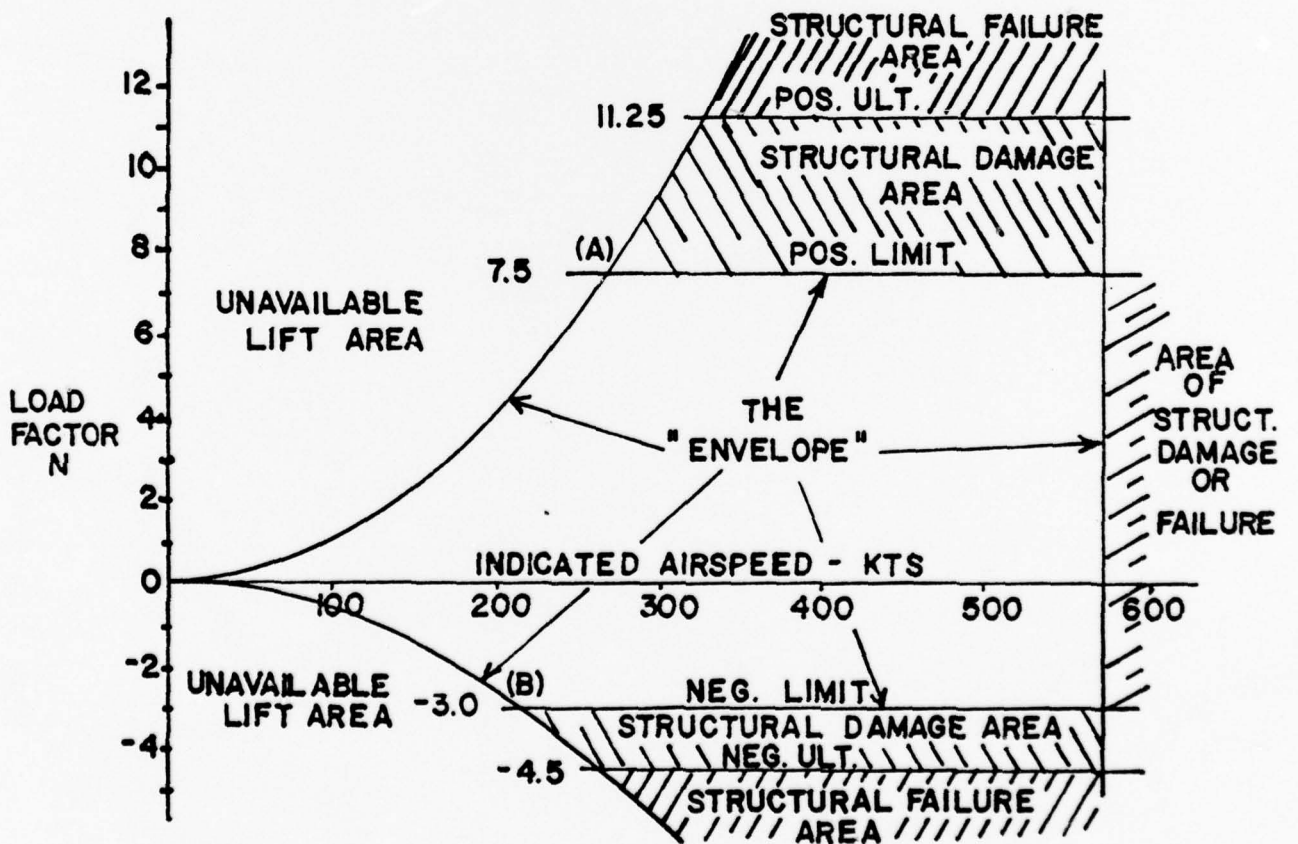

FIG. 5C-4

If the subject airplane is flown at a positive load factor greater than the positive limit load factor of 7.5, structural damage will be possible. When the airplane is operated in this region, objectionable permanent deformation of the primary structure may take place and a high rate of fatigue damage is incurred.

Operation above the limit load factor must be avoided in normal operation. If conditions of extreme emergency require load factors above the limit to prevent an immediate disaster, the airplane should be capable of withstanding the ultimate load factor without failure. The same situation exists in negative lift flight with the exception that the limit and ultimate load factors are of smaller magnitude and the negative limit load factor may not be the same value at all airspeeds. At speeds above the maximum level flight airspeed the negative limit load factor may be of smaller magnitude.

The limit airspeed (or redline speed) is a design reference point for the airplane - the subject airplane is limited to 575 knots. If flight is attempted beyond the limit airspeed structural damage or structural failure may result from a variety of phenomena.

A reasonable accounting of these items is required during the design of an airplane to prevent such occurrences in the required operating regions. The limit airspeed of an airplane may be any value between terminal dive speed and 1.2 times the maximum level flight speed depending on the aircraft type and mission requirement. Whatever the resulting limit airspeed happens to be, it deserves due respect.

Thus, the airplane in flight is limited to a regime of airspeeds and g's which do not exceed the limit (or redline) speed, do not exceed the limit

load factor, and cannot exceed the maximum lift capability. The airplane must be operated within this "envelope" to prevent structural damage and ensure that the anticipated service lift of the airplane is obtained. The pilot must appreciate the V-n diagram as describing the allowable combination of airspeeds and load factors for safe operation. Any maneuver, gust, or gust plus maneuver outside the structural envelope can cause structural damage and effectively shorten the service life of the airplane.

There are two points of great importance on the V-n diagram of figure 5C-4. Point B is the intersection of the negative limit load factor and line of maximum negative lift capability. Any airspeed greater than point B provides a negative lift capability sufficient to damage the airplane; any airspeed less than point B does not provide negative lift capability sufficient to damage the airplane from excessive flight loads. Point A is the intersection of the positive limit load factor and the line of maximum positive lift capability. The airspeed at this point is the minimum airspeed at which the limit load can be developed aerodynamically. Any airspeed greater than point A provides a positive lift capability sufficient to damage the airplane; any airspeed less than point A does not provide positive lift capability sufficient to cause damage from excessive flight loads. The usual term given to the speed at point A is the "maneuver speed", since consideration of subsonic aerodynamics would predict minimum usable turn radius to occur at this condition. The maneuver speed is a valuable reference point since an airplane operating below this point cannot produce a damaging positive flight load. Any combination of maneuver and gust cannot create damage due to excess airload when the airplane is below the maneuver speed.

The maneuver speed can be computed from equation 1. Of course, the stall speed and limit load factor must be appropriate for the airplane gross weight. One notable fact is that this speed, once properly computed, remains a constant value if no significant change takes place in the spanwise weight distribution. The maneuver speed of the subject aircraft of figure 5C-4 would be

$$\begin{aligned}V_p &= 100 \sqrt{7.5} \\ &= 274 \text{ knots}\end{aligned}$$

It is to be noted that the V-n Diagram is generally not symmetrical about the $n = 1$ axis due to the differences in the positive and negative limiting load factors, and the fact that stall generally occurs at a different velocity for positive and negative accelerations.

Military Specification MIL-F-8785B, "Flying Qualities for Piloted Aircraft", defines three flight envelopes as follows:

Operational - "...speed, altitude and load factor at which the airplane must be capable of operating in order to accomplish the missions ..."

Service - "...speed, altitude and normal acceleration derived from airplane limits as distinguished from mission requirements."

Permissible = "...all regions in which operation of the airplane is both allowable and possible... Stalls, spins, zooms and some dives may be representative of such conditions."

Figure 5C-5 depicts typical Operational and Service flight envelopes on a V-n Diagram.

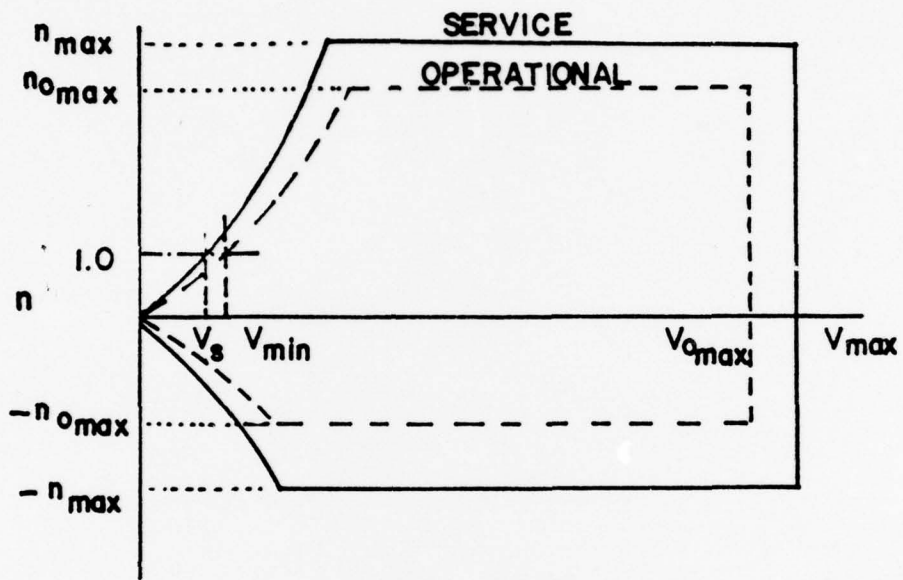

FIG. 5C-5

SUPPLEMENTARY PROBLEMS

UNIT 5

An aircraft has the following characteristics:

$$W = 35,000 \text{ lb}$$

$$C_{L_{\text{MAX}}} = 1.7$$

$$S = 530 \text{ ft}^2$$

$$n_L = 7.5$$

1. At an altitude of 30,000 feet, what is the coordinated level turning radius of this aircraft at a velocity of 350 knots TAS?
2. What is the coordinated level turning radius of this aircraft at 30,000 feet at a velocity of 520 knots?
3. Draw a V-n diagram for this aircraft (positive loads only) from V_S to $V = 600$ knots.
4. What is the maximum angle of bank for this aircraft at 30,000 feet in a level turn of constant velocity?
5. What is the maximum rate of turn for this aircraft at an altitude of 30,000 feet and a velocity of 485 knots?

SUPPLEMENTARY PROBLEMS

SOLUTION SHEET

UNIT 5

1. In order to determine the turn radius, one must first of all ascertain whether the aircraft is aerodynamically limited or structurally limited. To do this, one must calculate the Maneuver Speed, which is, in turn, a function of the Stall Speed. If the air speed in question is less than the Maneuver Speed, the aircraft is aerodynamically limited $(C_L)_{MAX}$. If the aircraft is flying faster than the Maneuver Speed, it is structurally limited $(n_z)_{MAX}$.

The stall speed is determined from the lift equation at $C_L = C_{LMAX}$.

$$V_S = \left(\frac{W \times 2}{C_{LMAX} \rho S} \right)^{\frac{1}{2}} = \left(\frac{35,000 \times 2}{1.7 \times 0.0023769 \times 0.3741 \times 530} \right)^{\frac{1}{2}}$$

$$V_S = 295.6 \text{ ft/sec} = 175 \text{ knots}$$

Inasmuch as the Maneuver Speed is the Stall Speed times the square root of the load factor,

$$V_P = V_S \times (n_z)^{\frac{1}{2}} = 175 \times (7.5)^{\frac{1}{2}} = 479 \text{ knots}$$

If the aircraft is flying at 450 knots, its air speed is less than the Maneuver Speed, and the aircraft is aerodynamically $(C_L)_{MAX}$ limited. Its actual load factor (which must be less than n_z) is determined by

$$n_z = \frac{L}{W} = \frac{1.7 \times \frac{1}{2} \times (0.0023769 \times 0.3741) \times 530 \times (350 \times 1.68894)^2}{35,000}$$

$$n_z = 4.0$$

$$\text{Since } \theta = \cos^{-1} \frac{1}{n_z} = \cos^{-1} \frac{1}{4} = 75.5^\circ$$

from Eq. (8), 5-A

$$R = \frac{V^2}{g} \frac{1}{\tan \theta} = \frac{(350 \times 1.68894)^2}{32.2} \frac{1}{\tan 75.5^\circ}$$

$$R = \underline{2,806 \text{ feet}}$$

SUPPLEMENTARY PROBLEMS

SOLUTION SHEET

UNIT 5

(Cont)

2. From the solution to Problem 1 it may be seen that at a velocity of 520 knots, the aircraft is structurally limited in a level turn. The angle of bank is therefore determined by the load factor, n_z .

$$\phi = \cos^{-1} \frac{1}{n_z} = \cos^{-1} \frac{1}{7.5} = 82.3^\circ$$

and the turning radius is

$$R = \frac{(520 \times 1.68894)^2}{32.2} \frac{1}{\tan 82.3^\circ}$$

$$R = \underline{1467 \text{ feet}}$$

3. Several points are known from the solution of Problem 1.

At $V_S = 175$ knots, $n_z = 1.0$ (by definition)

at $V = 350$ knots, $n_z = 4.0$

at $V_p = 479$ knots, $n_z = n_L = 7.5$

at $V = 479$ knots, $n_z = n_L = 7.5$

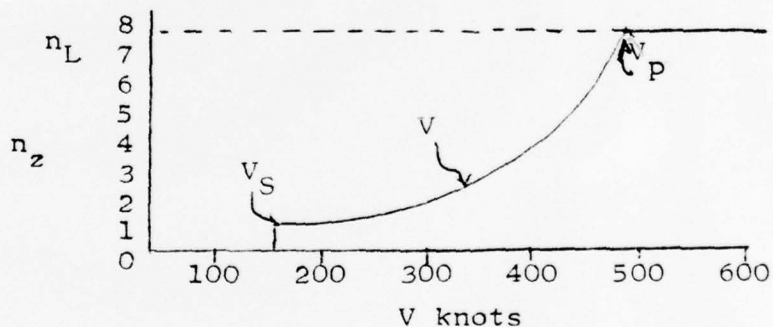

Note: From the equation

$$nW = L = C_L \frac{1}{2} \rho V^2 S$$

along the aerodynamic limit line ($C_L = C_{L_{MAX}}$), V^2 is proportional to n_z .

Since V_S is at $n_z = 1.0$, $2 \times V_S$ (350 knots) is at $n_z = 2^2 = 4$, et cetera.

SUPPLEMENTARY PROBLEMS

SOLUTION SHEET

UNIT 5

(Cont)

4. The maximum angle of bank sustained in a level turn occurs at the limit load factor ($n_z = n_L$). For $n_L = 7.5$

$$\underline{\phi_{MAX}} = \cos^{-1} \frac{1}{7.5} = \underline{82.3^\circ}$$

5. From Eq, (14), 5-A, the Rate of Turn is given by

$$\omega = \frac{g}{V} \tan \phi \text{ Radians/second}$$

for a velocity of 485 knots, the maximum angle of bank, as shown in Problem 4, is 82.3° . The turn rate (in degrees per second) is therefore

$$\omega_{MAX} = \frac{32.2}{(485 \times 1.68894)} \tan 82.3^\circ \times 57.3^\circ/\text{Radian}$$

$$\underline{\omega_{MAX} = 16.7^\circ/\text{second}}$$

AE-2306
PERFORMANCE II

UNIT 6

Takeoff Performance, Landing Performance

PERFORMANCE II

Unit 6 - Take-off Performance, Landing Performance

OBJECTIVES

As a result of your work in this Unit, you should be able to:

1. Draw a diagram for take-off and landing for an aircraft with uniformly accelerated motion. (Thrust, Drag, Friction, etc.).
2. State the effect of weight changes on take-off distance and take-off velocity for an aircraft with uniformly accelerated motion.
3. Explain why a headwind decreases take-off or landing distance less than a tailwind of the same velocity increases these distances.
4. State the effect of decreased density on take-off distance for the case where (a) the density change does not reduce acceleration, and (b) the case where density reduces acceleration.
5. Explain which portion of the landing rollout is most affected by aerodynamic braking and which portion is most affected by wheel braking.
6. Explain why a premature rotation may increase take-off distance.
7. Given the average aerodynamic drag, the average rolling friction, the thrust, the weight and the take-off velocity, determine the take-off distance.
8. Determine the effect of reduced braking friction coefficient (due to icing, wet runway, et cetera) on landing distance.

AE 2306

PERFORMANCE II

Unit 6

Procedures

1. Read Sections 6-A and 6-B.
2. Memorize Equations (1), (10), (13) and (14) in Section 6-A.
3. Review the Statement of Objectives.
4. Answer the Study Questions.
5. Review the resource material as necessary, based on your difficulty with the Study Questions.

When you are ready, ask for the written test on this Unit. This test will be Closed Book.

PERFORMANCE II

Unit 6

STUDY QUESTIONS

1. An aircraft has the following characteristics:

$$\begin{aligned} W &= 30,000 \text{ lb} & V_{TO} &= 1.15 V_S \\ C_{L_{MAX}} &= 1.1 \text{ (in ground effect)} \\ S &= 450 \text{ ft}^2 & h &= \text{Sea Level} \end{aligned}$$

The "average" accelerating force (computed at $0.707 V_{TO}$) is 10,130 lbs. What is the ground run take-off distance for this aircraft?

2. An aircraft has a normal touchdown velocity of 100 kts. A "hot pilot" touches down at a speed of 120 kts. How much more kinetic energy has he required the brakes to handle?
3. What is the increase in take-off velocity required and the increase in take-off distance if the weight is increased 20 per cent (no change in net acceleration force)?
4. If the drag of a deceleration chute is a direct function of the dynamic pressure, what is the effect of "popping" the chute one-half way down the runway as compared with "popping" it immediately after touchdown?
5. If maximum wheel braking is to be used, what should be done with the flaps after touchdown?
6. What is the effect of a 20 per cent headwind on take-off distance?
7. Provided that you can maintain directional control, what would be the effect of taking off on a runway covered with glaze ice?

AE 2306
PERFORMANCE II
Unit 6

STUDY QUESTIONS

1. $F = ma = \frac{W}{g} a = 10,130 \text{ lb}$

$$a = \frac{32.2}{30,000} \times 10,130 \text{ ft/sec}^2 = 10.9 \text{ ft/sec}^2$$

$$V_s = \left(\frac{2W}{\rho S C_{L_{\max}}} \right)^{\frac{1}{2}} = \left(\frac{2 \times 30,000}{0.002377 \times 450 \times 1.1} \right)^{\frac{1}{2}} = 225.8 \text{ ft/sec}$$

$$S = \frac{V_{TO}^2}{2a} = \frac{(1.15 \times 225.8)^2}{2 \times 10.9} = 3100 \text{ ft}$$

$$2. \frac{\Delta KE}{KE_1} = \frac{KE_2 - KE_1}{KE_1} = \frac{\left(\frac{1}{2} m v_2^2\right) - \left(\frac{1}{2} m v_1^2\right)}{\frac{1}{2} m v_1^2} = \frac{v_2^2 - v_1^2}{v_1^2} = \frac{v_2^2}{v_1^2} - 1$$

$$= \left[\frac{(120)^2}{(110)^2} - 1 \right] = .189 \text{ or } 18.9\% \text{ increase}$$

3. $V = f(W)$ if $W_2 = 1.20 W_1$, $V_2 = 1.10 V_1$ 10% increase

$S = f(V)^2 = f(W)$ ∴ $S_2 = 1.10 S_1$ 20% increase

4. $S = f(V^2)$

$q = f(V^2)$ therefore $q = f(S)$

Halfway down the runway the dynamic pressure is $1/2 q_{\text{Touchdown}}$

5. Raise the flaps (reduce lift) to put more weight on the wheels.

6. $\frac{S_2}{S_1} = \left(1 - \frac{V_w}{V_1}\right)^2 = \left(1 - \frac{0.2}{1}\right)^2 = 0.8^2 = 0.64$ 36% decrease

7. Shorter takeoff due to reduction of rolling friction.

Unit 6-A

Takeoff Performance

6A-1. INTRODUCTION

Takeoff and landing performance is a condition of accelerated motion. For instance, during takeoff the airplane starts at zero velocity and accelerates to the takeoff velocity to become airborne. During landing, the airplane touches down at the landing speed and decelerates (or accelerates negatively) to the zero velocity of the stop. In fact, the landing performance could be considered as a takeoff in reverse for purposes of study. In either case, takeoff or landing, the airplane is accelerated between zero velocity and the takeoff or landing velocity. The important factors of takeoff or landing performance are:

- (1) The takeoff or landing velocity which will generally be a function of the stall speed or minimum flying speed e.g., 15 percent above the stall speed.
- (2) The acceleration during the takeoff or landing roll which varies directly with the unbalance of force and inversely as the mass of the object.
- (3) The takeoff or landing roll distance which is a function of both the acceleration and velocity.

In the actual case, the takeoff and landing distance is related to velocity and acceleration in a very complex fashion. The main source of the complexity is that the forces acting on the airplane during the takeoff or landing roll are difficult to define with simple relationships. Since the acceleration is a function of these forces, the acceleration is difficult to define in a simple fashion and it is a principal variable affecting distance. However, some simplification can be made to study the basic relationship of acceleration, velocity, and distance. While the acceleration is not

necessarily constant or uniform throughout the takeoff or landing roll, the assumption of uniformly accelerated motion will facilitate study of the principal variables affecting takeoff and landing distance.

From basic physics, the relationship of velocity, acceleration, and distance for uniformly accelerated motion is defined by the following equation:

$$S = \frac{V^2}{2a} \quad (1)$$

where

S = acceleration distance, ft.

V = final velocity, ft. per sec., (after accelerating uniformly from zero velocity)

a = acceleration, ft. per sec.²

This equation could relate the takeoff distance in terms of the takeoff velocity and acceleration when the airplane is accelerated uniformly from zero velocity to the final takeoff velocity. Also, this expression could relate the landing distance in terms of the landing velocity and deceleration when the airplane is accelerated (negatively) from the landing velocity to a complete stop. It is important to note that the distance varies directly as the square of the velocity and inversely as the acceleration.

As an example of this relationship, assume that during takeoff an airplane is accelerated uniformly from zero velocity to a takeoff velocity of 150 knots (253.5 ft. per sec.) with an acceleration of 6.434 ft. per sec.² (or, 0.2g, since $g = 32.17$ ft. per sec.²). The takeoff distance would be:

$$\begin{aligned}
 s &= \frac{v^2}{2a} \\
 &= \frac{(253.5)^2}{(2)(6.434)} \\
 &= 5,000 \text{ ft.}
 \end{aligned}$$

If the acceleration during takeoff were reduced 10 percent, the takeoff distance would increase 11.1 percent; if the takeoff velocity were increased 10 percent, the takeoff distance would increase 21 percent. These relationships point to the fact that proper accounting must be made of altitude, temperature, gross weight, wind, etc. because any item affecting acceleration or takeoff velocity will have a definite effect on takeoff distance.

If an airplane were to land at a velocity of 150 knots and be decelerated uniformly to a stop with the same acceleration of 0.2g, the landing stop distance would be 5,000 ft. It would be extremely rare for an aircraft to have identical takeoff and landing performance, but the principle illustrated is that distance is a function of velocity and acceleration. As before, a 10 percent lower acceleration increases stop distance 11.1 percent, and a 10 percent higher landing speed increases landing distance 21 percent.

6A-2. TAKEOFF PERFORMANCE

The minimum takeoff distance is of primary interest in the operation of any aircraft because it defines the runway requirements. The minimum takeoff distance is obtained by takeoff at some minimum safe velocity which allows sufficient margin above stall and provides satisfactory control and initial rate of climb. Generally, the takeoff speed is some fixed percentage of the stall speed or minimum control speed for the airplane in the takeoff configuration. As such, the takeoff will be accomplished at some particular

value of lift coefficient and angle of attack. Depending on the airplane characteristics, the takeoff speed will be anywhere from 1.05 to 1.25 times the stall speed or minimum control speed. If the takeoff speed is specified as 1.10 times the stall speed, the takeoff lift coefficient is 82.6 percent of $C_{L_{MAX}}$ and the angle of attack and lift coefficient for takeoff are fixed values independent of weight, altitude, wind, etc. Hence, an angle of attack indicator can be a valuable aid during takeoff.

To obtain minimum takeoff distance at the specified takeoff velocity, the forces which act on the aircraft must provide the maximum acceleration during the takeoff roll. The various forces acting on the aircraft may or may not be at the control of the pilot and various techniques may be necessary in certain airplanes to maintain takeoff acceleration at the highest value.

Figure 6A-1 illustrates the various forces which act on the aircraft during takeoff roll. The powerplant thrust is the principal force to provide the acceleration and, for minimum takeoff distance, the output thrust should be at a maximum. Lift and drag are produced as soon as the airplane has speed and the values of lift and drag depend on the angle of attack and dynamic pressure. Rolling friction results when there is a normal force on the wheels and the friction force is the product of the normal force and the coefficient of rolling friction (μ). The normal force pressing the wheels against the runway surface is the net of weight and lift while the rolling friction coefficient is a function of the tire type and runway surface texture.

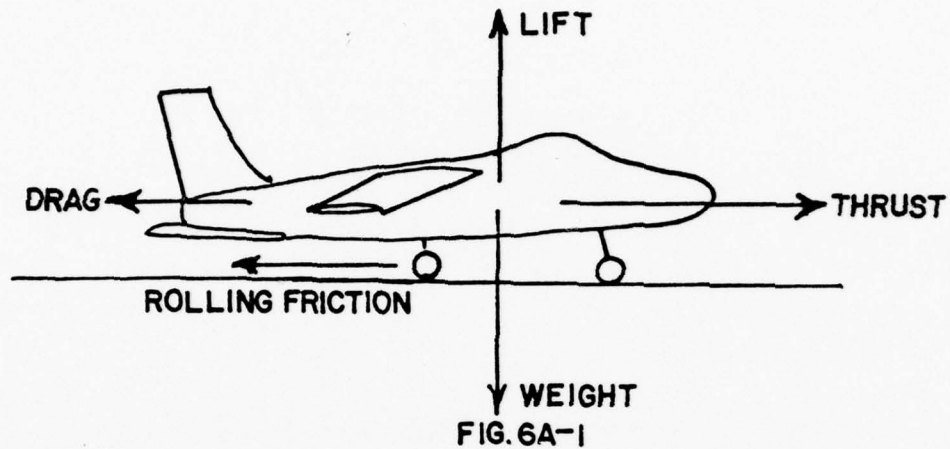

The acceleration of the airplane at any instant during takeoff roll is a function of the net accelerating force and the airplane mass. From Newton's second law of motion:

$$a = F_n/M \quad (2)$$

or

$$a = g(F_n/W)$$

where

a = acceleration, ft. per sec.²

F_n = net accelerating force, lbs.

W = weight, lbs.

g = gravitational acceleration

= 32.17 ft. per sec.²

M = mass, slugs

= W/g

The net accelerating force on the airplane, F_n , is the net of thrust, T , drag, D , and rolling friction, F . Thus, the acceleration at any instant during takeoff roll is:

$$a = \frac{g}{W} (T - D - F)$$

Figure 6A-2 illustrates the typical variation of the various forces acting on the aircraft throughout the takeoff roll. If it is assumed that the aircraft is at essentially constant angle of attack during takeoff roll, C_L and C_D are constant and the forces of lift and drag vary as the square of the speed. For the case of uniformly accelerated motion, distance along the takeoff roll is proportional also to the square of the velocity hence velocity squared and distance can be used almost synonymously. Thus, lift and drag will vary linearly with dynamic pressure (q) or V^2 from the point of beginning takeoff roll. As the rolling friction coefficient is essentially unaffected by velocity, the rolling friction will vary as the normal force on the wheels. At zero velocity, the normal force on the wheels is equal to the airplane weight but, at takeoff velocity, the lift is equal to the weight and the normal force is zero. Hence, rolling friction decreases linearly with q or V^2 from the beginning of takeoff roll and reaches zero at the point of takeoff.

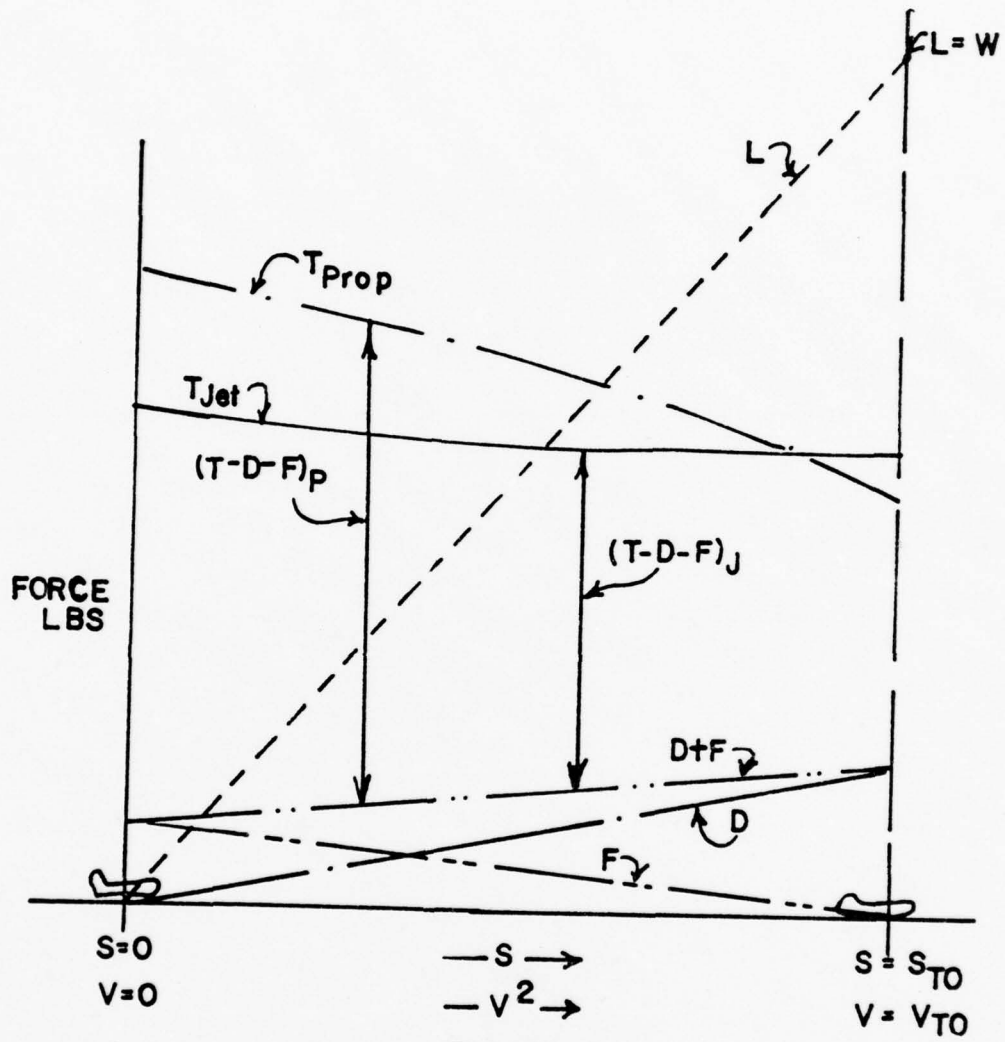

FIG. 6A-2

The total retarding force on an aircraft is the sum of drag and rolling friction ($D + F$) and, for the majority of configurations, this sum is nearly constant or changes only slightly during the takeoff roll. The net accelerating force is then the difference between the powerplant thrust and the total retarding force.

$$F_n = T - D - F$$

The variation of the net accelerating force throughout the takeoff roll is shown in figure 6A-2. The typical propeller airplane demonstrates a net accelerating force which decreases with velocity and the resulting acceleration is initially high but decreases throughout the takeoff roll. The typical jet airplane demonstrates a net accelerating force which is essentially constant throughout the takeoff roll. As a result, the takeoff performance of the typical turbojet airplane will compare closely with the case for uniformly accelerated motion.

The pilot technique required to achieve peak acceleration throughout takeoff roll can vary considerably between airplane configurations. In some instances, maximum acceleration will be obtained by allowing the airplane to remain in the three-point attitude throughout the roll until the airplane simply reaches lift-equal-to-weight and flies off the ground. Other airplanes may require the three-point attitude until the takeoff speed is reached then rotation to the takeoff angle of attack to become airborne. Still other configurations may require partial or complete rotation to the takeoff angle of attack prior to reaching the takeoff speed. In this case, the procedure may be necessary to provide a smaller retarding force ($D + F$) to achieve peak acceleration. Whenever any form of pitch rotation is necessary, the pilot

must provide the proper angle of attack since an excessive angle of attack will cause excessive drag and hinder (or possibly preclude) a successful takeoff. Also, insufficient rotation may provide added rolling resistance or require that the airplane accelerate to some excessive speed prior to becoming airborne. In this sense, an angle of attack indicator is especially useful for night or instrument takeoff conditions as well as the ordinary day VFR takeoff conditions. Acceleration errors of the attitude gyro usually preclude accurate pitch rotation under these conditions.

6A-3. TAKEOFF PERFORMANCE PARAMETERS

In addition to the important factors of proper technique, many other variables affect the takeoff performance of an airplane. Any item which alters the takeoff velocity or acceleration during takeoff roll will affect the takeoff distance. In order to evaluate the effect of the many variables, the principal relationships of uniformly accelerated motion will be assumed and consideration will be given to those effects due to any nonuniformity of acceleration during the process of takeoff. Generally, in the case of uniformly accelerated motion, distance varies directly with the square of the takeoff velocity and inversely as the takeoff acceleration.

$$\frac{S_2}{S_1} = \frac{(V_2)^2}{(V_1)^2} \times \frac{(a_1)}{(a_2)} \quad (3)$$

where

S = distance

V = velocity

a = acceleration

Condition (1) applies to some known takeoff distance, S_1 , which was common to some original takeoff velocity, V_1 , and the acceleration, a_1 .

Condition (2) applies to some new takeoff distance, S_2 , which is the result of some different value of takeoff velocity, V_2 , or acceleration a_2 .

With this basic relationship, the effect of the many variables on takeoff distance can be approximated.

The effect of gross weight on takeoff distance is large and proper consideration of this item must be made in predicting takeoff distance. Increased gross weight can be considered to produce a threefold effect on takeoff performance: (1) increased takeoff velocity required, (2) greater mass to accelerate, and (3) increased retarding force ($D + F$). If the gross weight increases, a greater speed is necessary to produce the greater lift to get the airplane airborne at the takeoff lift coefficient. The relationship of takeoff speed and gross weight would be as follows:

$$\frac{V_2}{V_1} = \sqrt{\frac{W_2}{W_1}} \text{ (EAS or CAS)} \quad (4)$$

where

V_1 = takeoff velocity corresponding to some original weight, W_1

V_2 = takeoff velocity corresponding to some different weight, W_2

Thus, a given airplane in the takeoff configuration at a given gross weight will have a specific takeoff speed (EAS or CAS) which is invariant with altitude, temperature, wind, etc. because a certain value of q is necessary to

provide lift equal to weight at the takeoff. As an example of the effect of a change in gross weight, a 21 percent increase in takeoff weight will require a 10 percent increase in takeoff speed to support the greater weight.

A change in gross weight will change the net accelerating force, F_n , and change the mass, M , which is being accelerated. If the airplane has a relatively high thrust-to-weight ratio, the change in the net accelerating force is slight and the principal effect on acceleration is due to the change in mass.

To evaluate the effect of gross weight on takeoff distance, the following relationships are used:

the effect of weight on takeoff velocity is

$$\frac{v_2}{v_1} = \sqrt{\frac{w_2}{w_1}} \quad \text{or} \quad \frac{(v_2)^2}{(v_1)^2} = \frac{w_2}{w_1} \quad (5)$$

If the change in net accelerating force is neglected, the effect of weight on acceleration is

$$\frac{a_1}{a_2} = \frac{w_2}{w_1} \quad \text{or} \quad \frac{a_2}{a_1} = \frac{w_1}{w_2} \quad (6)$$

the effect of these items on takeoff distance is

$$\frac{s_2}{s_1} = \frac{(v_2)^2}{(v_1)^2} \times \frac{a_1}{a_2} \quad (7)$$

or

$$\begin{aligned} \frac{s_2}{s_1} &= \left(\frac{w_2}{w_1}\right) \times \left(\frac{w_2}{w_1}\right) \\ \frac{s_2}{s_1} &= \left(\frac{w_2}{w_1}\right)^2 \end{aligned} \quad (8)$$

(at least this effect because weight will alter the net accelerating force)

This result approximates the effect of gross weight on takeoff distance for airplanes with relatively high thrust-to-weight ratios. In effect, the takeoff distance will vary at least as the square of the gross weight. For example, a 10 percent increase in takeoff gross weight would cause:

- a 5 percent increase in takeoff velocity
- at least a 9 percent decrease in acceleration
- at least a 21 percent increase in takeoff distance

For the airplane with a high thrust-to-weight ratio, the increase in takeoff distance would be approximately 21 to 22 percent but, for the airplane with a relatively low thrust-to-weight ratio, the increase in takeoff distance would be approximately 25 to 30 percent. Such a powerful effect requires proper consideration of gross weight in predicting takeoff distance.

The effect of wind on takeoff distance is large and proper consideration also must be provided when predicting takeoff distance. The effect of a headwind is to allow the airplane to reach the takeoff velocity at a lower ground velocity while the effect of a tailwind is to require the airplane to achieve a greater ground velocity to attain the takeoff velocity. The effect of the wind on acceleration is relatively small and, for the most part, can be neglected. To evaluate the effect of wind on takeoff distance, the following relationships are used:

the effect of a headwind is to reduce the takeoff ground velocity by the amount of the headwind velocity, V_w

$$V_2 = V_1 - V_w \quad (9)$$

the effect of wind on acceleration is negligible,

$$a_2 = a_1 \text{ or } \frac{a_1}{a_2} = 1$$

the effect of these items on takeoff distance is

$$\frac{s_2}{s_1} = \frac{(v_2)^2}{(v_1)^2} \times \frac{a}{a}$$

$$\frac{s_2}{s_1} = \left(\frac{v_1 - v}{v_1} \right)^2$$

or

$$\frac{s_2}{s_1} = \left(1 - \frac{v_w}{v_1} \right)^2 \quad (10)$$

where

S_1 = zero wind takeoff distance

S_2 = takeoff distance into the headwind

V_w = wind velocity (positive for headwind, negative for tailwind)

V_1 = takeoff ground velocity with zero wind or, simply, the takeoff
airspeed

As a result of this relationship, a headwind which is 10 percent of the takeoff airspeed will reduce the takeoff distance 19 percent. However, a tailwind (or negative headwind) which is 10 percent of the takeoff airspeed will increase the takeoff distance 21 percent. In the case where the headwind velocity is 50 percent of the takeoff speed, the takeoff distance would be approximately 25 percent of the zero wind takeoff distance (75 percent reduction).

The effect of wind on landing distance is identical to the effect on takeoff distance. Figure 6A-3 illustrates the general effect of wind by the percent change in takeoff or landing distance as a function of the ratio of wind velocity to takeoff or landing speed.

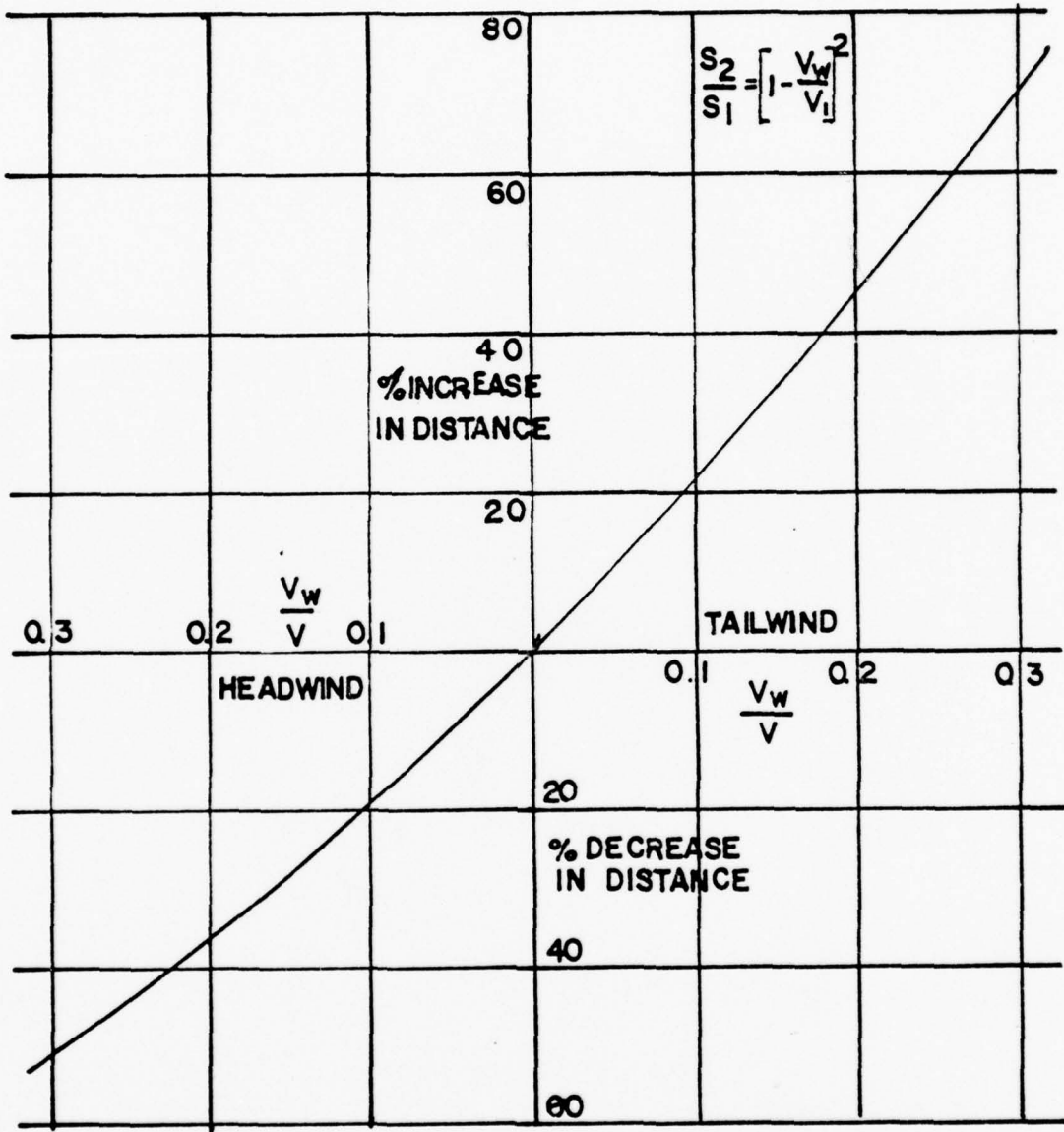

FIG. 6A-3

The effect of runway slope on takeoff distance is due to the component of weight along the inclined path of the airplane. A runway slope of 1 percent would provide a force component along the path of the airplane which is 1 percent of the gross weight. Of course, an upslope would contribute a retarding force component while a downslope would contribute an accelerating force component. For the case of the upslope, the retarding force component adds to drag and rolling friction and reduces the net accelerating force. Ordinarily, a 1 percent runway slope can cause a 2 to 4 percent change in takeoff distance depending on the airplane characteristics. The airplane with the high thrust-to-weight ratio is least affected while the airplane with the low thrust-to-weight ratio is most affected because the slope force component causes a relatively greater change in the net accelerating force.

The effect of runway slope must be considered when predicting the takeoff distance but the effect is usually minor for the ordinary runway slopes

and airplanes with moderate thrust-to-weight ratios. In fact, runway slope considerations are of great significance only when the runway slope is large and the airplane has an intrinsic low acceleration, i.e., low thrust-to-weight ratio. In the ordinary case, the selection of the takeoff runway will favor the direction with an upslope and headwind rather than the direction with a downslope and tailwind.

The effect of proper takeoff velocity is important when runway lengths and takeoff distances are critical. The takeoff speeds specified in the flight handbooks are generally the minimum safe speeds at which the airplane can become airborne. An attempt to take off below the recommended speed may mean that the aircraft may stall, be difficult to control, or have very low initial rate of climb. In some cases, an excessive angle of attack may not allow the airplane to climb out of ground effect. On the other hand, an excessive airspeed at takeoff may improve the initial rate of climb and "feel" of the airplane but will produce an undesirable increase in takeoff distance. Assuming that the acceleration is essentially unaffected, the takeoff distance varies as the square of the takeoff velocity,

$$\frac{S_2}{S_1} = \frac{(V_2)^2}{(V_1)^2} \quad (11)$$

Thus, 10 percent excess airspeed would increase the takeoff distance 21 percent. In most critical takeoff conditions, such an increase in takeoff distance would be prohibitive and the pilot must adhere to the recommended takeoff speeds.

The effect of pressure altitude and ambient temperature is to define primarily the density altitude and its effect on takeoff performance.

While subsequent corrections are appropriate for the effect of temperature on certain items of powerplant performance, density altitude defines certain effects on takeoff performance. An increase in density altitude can produce a two-fold effect on takeoff performance: (1) increased takeoff velocity required and (2) decreased thrust and reduced net accelerating force. If a given weight and configuration of airplane is taken to altitude above standard sea level, the airplane will still require the same dynamic pressure to become airborne at the takeoff lift coefficient. Thus, the airplane at altitude will take off at the same equivalent airspeed (EAS) as at sea level, but because of the reduced density, the true airspeed (TAS) will be greater. From basic aerodynamics, the relationship between true airspeed and equivalent airspeed is as follows:

$$\frac{TAS}{EAS} = \frac{1}{\sqrt{\sigma}} \quad (12)$$

where

TAS = true airspeed

EAS ± equivalent airspeed

σ = altitude density ratio = ρ/ρ_0

The effect of density altitude on powerplant thrust depends much on the type of powerplant. An increase in altitude above standard sea level will bring an immediate decrease in power output for the unsupercharged or ground boosted reciprocating engine or the turbojet and turboprop engines. However, an increase in altitude above standard sea level will not cause a decrease in power output for the supercharged reciprocating engine until the altitude exceeds the critical altitude. For those powerplants which experience a decay

in thrust with an increase in altitude, the effect on the net accelerating force and acceleration can be approximated by assuming a direct variation with density. Actually, this assumed variation would closely approximate the effect on airplanes with high thrust-to-weight ratios. This relationship would be as follows:

$$\frac{a_2}{a_1} = \frac{Fn_2}{Fn_1} = \frac{\rho}{\rho_0} = \sigma \quad (12)$$

where

a_1, Fn_1 = acceleration and net accelerating force corresponding to sea level

a_2, Fn_2 = acceleration and net accelerating force corresponding to altitude

σ = altitude density ratio

In order to evaluate the effect of these items on takeoff distance, the following relationships are used:

if an increase in altitude does not alter acceleration, the principal effect would be due to the greater TAS

$$\frac{S_2}{S_1} = \frac{(V_2)^2}{(V_1)^2} \approx \frac{a_1}{a_2} \quad (13)$$

$$\frac{S_2}{S_1} = \left(\frac{1}{\sigma}\right)$$

where

S_1 = standard sea level takeoff distance

S_2 = takeoff distance at altitude

σ = altitude density ratio

if an increase in altitude reduces acceleration in addition to the increase in TAS, the combined effects would be approximated for the case of the airplane with high intrinsic acceleration by the following:

$$\frac{S_2}{S_1} = \frac{(v_2)^2}{(v_1)^2} \times \frac{a_1}{a_2}$$

$$\frac{S_2}{S_1} = \left(\frac{1}{\sigma}\right) \times \left(\frac{1}{\sigma}\right)$$

$$\frac{S_2}{S_1} = \left(\frac{1}{\sigma}\right)^2 \tag{14}$$

where

S_1 = standard sea level takeoff distance

S_2 = takeoff distance at altitude

σ = altitude density ratio

As a result of these relationships, it should be appreciated that density altitude will affect takeoff performance in a fashion depending much on the powerplant type. The effect of density altitude on takeoff distance can be appreciated by the following comparison:

Approximate Effect of Altitude on Takeoff Distance

Density Altitude	σ	$\frac{1}{\sigma}$	$\left(\frac{1}{\sigma}\right)^2$	Percent increase in takeoff distance from standard sea level		
				Super- charged recipro- cating airplane below critical altitude	Turbo- jet high (T/W)	Turbo- jet low (T/W)
Sea level	1.000	1.000	1.000	0	0	0
1,000 ft	.9711	1.0298	1.0605	2.98	6.05	9.8
2,000 ft	.9428	1.0605	1.125	6.05	12.5	19.9
3,000 ft	.9151	1.0928	1.195	9.28	19.5	30.1
4,000 ft	.8881	1.126	1.264	12.6	26.4	40.6
5,000 ft	.8617	1.1605	1.347	16.05	34.7	52.3
6,000 ft	.8359	1.1965	1.432	19.65	43.2	65.8

From the previous table, some approximate rules of thumb may be derived to illustrate the differences between the various airplane types. A 1,000-ft. increase in density altitude will cause these approximate increases in take-off distance:

3-1/2 percent for the supercharged reciprocating airplane when below critical altitude

7 percent for the turbojet with high thrust-to-weight ratio

10 percent for the turbojet with low thrust-to-weight ratio

These approximate relationships show the turbojet airplane to be much more

sensitive to density altitude than the reciprocating powered airplane. This is an important fact which must be appreciated by pilots in transition from propeller type to jet type airplanes. Proper accounting of pressure altitude (field elevation is a poor substitute) and temperature is mandatory for accurate prediction of takeoff roll distance.

The most critical conditions of takeoff performance are the result of some combination of high gross weight, altitude, temperature and unfavorable wind. In the prediction of takeoff distance, the following primary considerations must be given:

Reciprocating powered airplane

- (1) Pressure altitude and temperature - to define the effect of density altitude on distance.
- (2) Gross weight - a large effect on distance.
- (3) Specific humidity - to correct takeoff distance for the power loss associated with water vapor.
- (4) Wind - a large effect due to the wind or wind component along the runway.

Turbine powered airplane

- (1) Pressure altitude and temperature - to define the effect of density altitude.
- (2) Gross weight.
- (3) Temperature - an additional correction for nonstandard temperatures to account for the thrust loss associated with high compressor inlet air temperature. For this correction the ambient temperature at the runway conditions is appropriate rather than the ambient temperature

temperature at some distant location.

(4) Wind.

In addition, corrections are necessary to account for runway slope, engine power deficiencies, etc.

Unit 6-B

Landing Performance

6B-1. LANDING PERFORMANCE

In many cases, the landing distance of an airplane will define the runway requirements for flying operations. This is particularly the case of high speed jet airplanes at low altitudes where landing distance is the major problem rather than takeoff performance. The minimum landing distance is obtained by landing at some minimum safe velocity which allows sufficient margin above stall and provides satisfactory control and capability for waveoff. Generally, the landing speed is some fixed percentage of the stall speed or minimum control speed for the airplane in the landing configuration. As such, the landing will be accomplished at some particular value of lift coefficient and angle of attack. The exact value of C_L and α for landing will depend on the airplane characteristics but, once defined, the values are independent of weight, altitude, wind, etc. Thus, an angle of attack indicator can be a valuable aid during approach and landing.

To obtain minimum landing distance at the specified landing velocity, the forces which act on the airplane must provide maximum deceleration (or negative acceleration) during the landing roll. The various forces acting on the airplane during the landing roll may require various techniques to maintain landing deceleration at the peak value.

Figure 6B-1 illustrates the forces acting on the aircraft during landing roll. The power-plant thrust should be a minimum positive value, or, if reverse thrust is available, a maximum negative value for minimum landing distance. Lift and drag are produced as long as the airplane has speed and the values of lift and drag depend on dynamic pressure and angle of attack. Braking friction results when there is a normal force on the braking wheel

surfaces and the friction force is the product of the normal force and the coefficient of braking friction. The normal force on the braking surfaces is some part of the net of weight and lift, i.e., some other part of this net may be distributed to wheels which have no brakes. The maximum coefficient of braking friction is primarily a function of the runway surface condition (dry, wet, icy, etc.) and rather independent of the type of tire for ordinary conditions (dry, hard surface runway). However, the operating coefficient of braking friction is controlled by the pilot by the use of brakes.

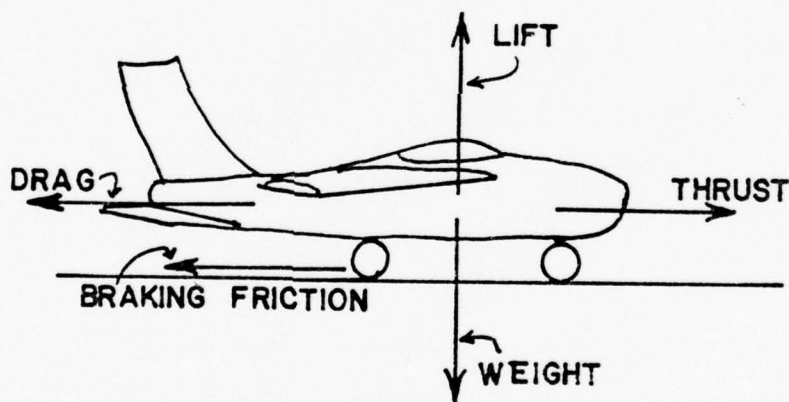

FIG. 6B-1

The acceleration of the airplane during the landing roll is negative (deceleration) and will be considered to be in that sense. At any instance during the landing roll the acceleration is a function of the net retarding force and the airplane mass. From Newton's second law of motion:

$$a = Fr/M$$

or

$$a = g(Fr/W)$$

where

a = acceleration, ft. per sec.² (negative)

Fr = net retarding force, lbs.

g = gravitational acceleration, ft. per sec.²

W = weight, lbs.

M = mass, slugs

$$= W/g$$

The net retarding force on the airplane, FR, is the net of drag (D), braking friction (F), and thrust (T). Thus, the acceleration (negative) at any instant during the landing roll is:

$$a = \frac{g}{W} (D + F - T)$$

Figure 6B-2 illustrates the typical variation of the various forces acting on the aircraft throughout the landing roll. If it is assumed that the aircraft is at essentially constant angle of attack from the point of touchdown, C_L , and C_D are constant and the forces of lift and drag vary as the square of the velocity. Thus, lift and drag will decrease linearly with q or V^2 from the point of touchdown. If the braking coefficient is maintained at the maximum value, this maximum value of coefficient of friction is essentially constant with speed and the braking friction force will vary as the normal force on the braking surfaces. As the airplane nears a complete stop, the velocity and lift approach zero and the normal force on the wheels approaches the weight of the airplane. At this point, the braking friction

force is at a maximum. Immediately after touchdown, the lift is quite large and the normal force on the wheels is small. As a result, the braking friction force is small. A common error at this point is to apply excessive brake pressure without sufficient normal force on the wheels. This may develop a skid with a locked wheel and cause the tire to blow out, so suddenly that judicious use of the brakes is necessary.

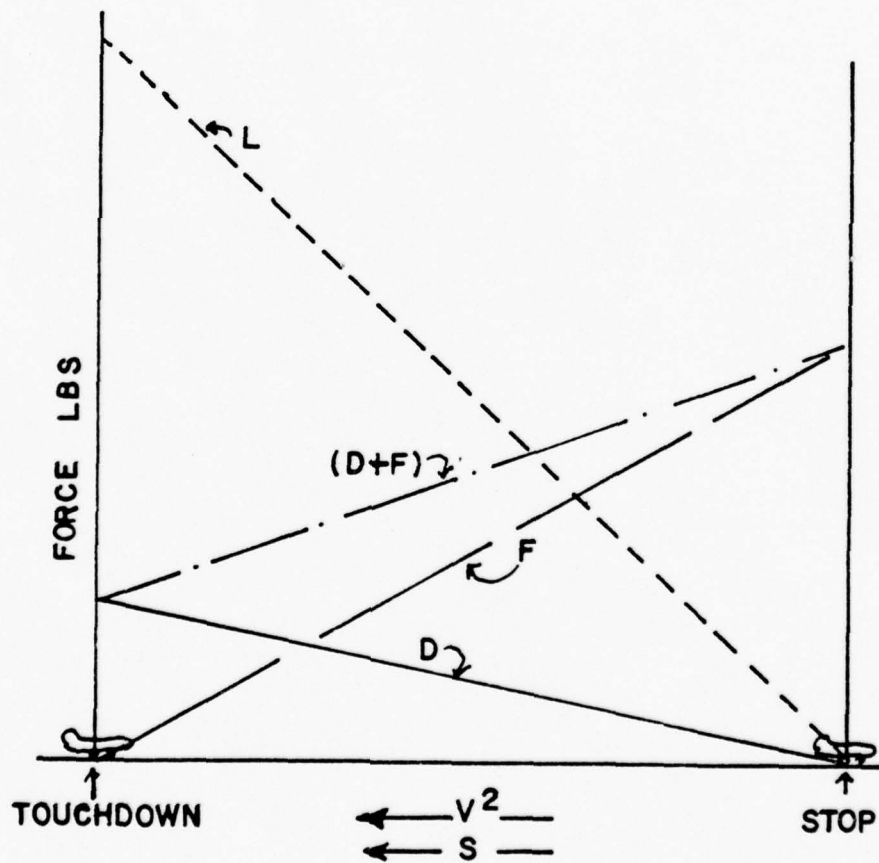

FIG. 6B-2

The coefficient of braking friction can reach peak values of 0.8 but ordinarily values near 0.5 are typical for the dry, hard surface runway. Of course, a slick, icy runway can reduce the maximum braking friction coefficient to values as low as 0.2 or 0.1. If the entire weight of the airplane were the normal force on the braking surfaces, a coefficient of braking friction of 0.5 would produce a deceleration of $\frac{1}{2}g$, 16.1 ft. per sec.² Most airplanes in ground effect rarely produce lift-drag ratios lower than 3 or 4. If the lift of the airplane were equal to the weight, an $L/D = 4$ would produce a deceleration of $\frac{1}{4}g$, 8 ft. per sec.² By this comparison it should be apparent that friction braking offers the possibility of greater deceleration than airplane aerodynamic braking. To this end, the majority of airplanes operating from dry hard surface runways will require particular techniques to obtain minimum landing distance. Generally, the technique involves lowering the nose wheel to the runway and retracting the flaps to increase the normal force on the braking surfaces. While the airplane drag is reduced, the greater normal force can provide greater braking friction force to compensate for the reduced drag and the net retarding force is increased.

The technique necessary for minimum landing distance can be altered to some extent in certain situations. For example, low aspect ratio airplanes with high longitudinal control power can create very high drag at the high speeds immediately prior to landing touchdown. If the landing gear configuration or flap or incidence setting precludes a large reduction of C_L , the normal force on the braking surfaces and braking friction force capability are relatively small. Thus, in the initial high speed part of the landing roll, maximum deceleration would be obtained by creating the greatest

possible aerodynamic drag. By the time the aircraft has slowed to 70 or 80 percent of the touchdown speed, aerodynamic drag decays but braking action will then be effective. Some form of this technique may be necessary to achieve minimum distance for some configurations when the coefficient of braking friction is low (wet, icy runway) and the braking friction force capability is reduced relative to airplane aerodynamic drag.

A distinction should be made between the techniques for minimum landing distance and an ordinary landing roll with considerable excess runway available. Minimum landing distance will be obtained from the landing speed by creating a continuous peak deceleration of the airplane. This condition usually requires extensive use of the brakes for maximum deceleration. On the other hand, an ordinary landing roll with considerable excess runway may allow extensive use of aerodynamic drag to minimize wear and tear on the tires and brakes. If aerodynamic drag is sufficient to cause deceleration of the airplane it can be used in deference to the brakes in the early stages of the landing roll, i.e., brakes and tires suffer from continuous, hard use but airplane aerodynamic drag is free and does not wear out with use. The use of aerodynamic drag is applicable only for deceleration to 60 or 70 percent of the touchdown speed. At speeds less than 60 to 70 percent of the touchdown speed, aerodynamic drag is so slight as to be of little use and braking must be utilized to produce continued deceleration of the airplane.

Powerplant thrust is not illustrated on figure 6B-2 because there are so many possible variations. Since the objective during the landing roll is to decelerate, the powerplant thrust should be the smallest possible positive value or largest possible negative value. In the case of the turbojet

aircraft, the idle thrust of the engine is nearly constant with speed throughout the landing roll. The idle thrust is of significant magnitude on cold days because of the low compressor inlet air temperature and low density, altitude. Unfortunately, such atmospheric conditions usually have the corollary of poor braking action because of ice or water on the runway. The thrust from a windmilling propeller with the engine at idle can produce large negative thrust early in the landing roll but the negative force decreases with speed. The large negative thrust at high speed is valuable in adding to drag and braking friction to increase the net retarding force.

Various devices can be utilized to provide greater deceleration of the airplane or to minimize the wear and tear on tires and brakes. The drag parachute can provide a large retarding force at high q and greatly increase the deceleration during the initial phase of landing roll. It should be noted that the contribution of the drag chute is important only during the high speed portion of the landing roll. For maximum effectiveness, the drag chute must be deployed immediately after the airplane is in contact with the runway. Reverse thrust of propellers is obtained by rotating the blade angle well below the low pitch stop and applying engine power. The action is to extract a large amount of momentum from the airstream and thereby create negative thrust. The magnitude of the reverse thrust from propellers is very large, especially in the case of the turboprop where a very large shaft power can be fed into the propeller. In the case of reverse propeller thrust, maximum effectiveness is achieved by use immediately after the airplane is in contact with the runway. The reverse thrust capability is greatest at the high speed and, obviously, any delay in producing deceleration allows

runway to pass by at a rapid rate. Reverse thrust of turbojet engines will usually employ some form of vanes, buckets, or clamshells in the exhaust to turn or direct the exhaust gases forward. Whenever the exit velocity is less than the inlet velocity (or negative), a negative momentum change occurs and negative thrust is produced. The reverse jet thrust is valuable and effective but it should not be compared with the reverse thrust capability of a comparable propeller powerplant which has the high intrinsic thrust at low velocities. As with the propeller reverse thrust, jet reverse thrust must be applied immediately after ground contact for maximum effectiveness in reducing landing distance.

6B-2. PARAMETERS

In addition to the important factors of proper technique, many other variables effect the landing performance of an airplane. Any item which alters the landing velocity or deceleration during landing roll will affect the landing distance. As with takeoff performance, the relationships of uniformly accelerated motion defines landing distance as varying directly as the square of the landing velocity and inversely as the acceleration during landing roll.

$$\frac{S_2}{S_1} = \frac{(V_2)^2}{(V_1)^2} \times \frac{a_1}{a_2} \quad (1)$$

where

S_1 = landing distance resulting from certain values of landing velocity, V_1 , and acceleration, a_1

S_2 = landing distance resulting from some different values of landing velocity, V_2 , or acceleration, a_2

With this relationship, the effect of the many variables on landing distance can be approximated.

The effect of gross weight on landing distance is one of the principal items determining the landing distance of an airplane. One effect of an increased gross weight is that the airplane will require a greater speed to support the airplane at the landing angle of attack and lift coefficient. The relationship of landing speed and gross weight would be as follows:

$$\frac{V_2}{V_1} = \sqrt{\frac{W_2}{W_1}} \text{ (EAS or CAS)} \quad (2)$$

where

V_1 = landing velocity corresponding to some original weight, W_1

V_2 = landing velocity corresponding to some different weight, W_2

Thus, a given airplane in the landing configuration at a given gross weight will have a specific landing speed (EAS or CAS) which is invariant with altitude, temperature, wind, etc., because a certain value of q is necessary to provide lift equal to weight at the landing C_L . As an example of the effect of a change in gross weight, a 21 percent increase in landing weight will require a 10 percent increase in landing speed to support the greater weight.

When minimum landing distances are considered, braking friction forces predominate during the landing roll and, for the majority of airplane configurations, braking friction is the main source of deceleration. In this case, an increase in gross weight provides a greater normal force and increased braking friction force to cope with the increased mass. Also, the higher landing speed at the same C_L and C_D produce an average drag which

increased in the same proportion as the increased weight. Thus, increased gross weight causes like increases in the sum of drag plus braking friction and the acceleration is essentially unaffected.

To evaluate the effect of gross weight on landing distance, the following relationships are used:

the effect of weight on landing velocity is

$$\frac{v_2}{v_1} = \sqrt{\frac{W_2}{W_1}} \quad \text{or} \quad \frac{(v_2)^2}{(v_1)^2} = \frac{W_2}{W_1} \quad (3)$$

if the net retarding force increases in the same proportion as the weight, the acceleration is unaffected.

the effect of weight on landing velocity is

$$\frac{s_2}{s_1} = \frac{(v_2)^2}{(v_1)^2} \times \frac{a_1}{a_2}$$

or

$$\frac{s_2}{s_1} = \frac{W_2}{W_1} \quad (4)$$

In effect, the minimum landing distance will vary directly as the gross weight.

For example, a 10 percent increase in gross weight at landing would cause:

a 5 percent increase in landing velocity

a 10 percent increase in landing distance

A contingency of the previous analysis is the relationship between weight and braking friction force. The maximum coefficient of braking friction is relatively independent of the usual range of normal forces and

rolling speeds, e.g., a 10 percent increase in normal force would create a similar 10 percent increase in braking friction force. Consider the case of two airplanes of the same type and c.g. position but of different gross weights. If these two airplanes are rolling along the runway at some speed at which aerodynamic forces are negligible, the use of the maximum coefficient of braking friction will bring both airplanes to a stop in the same distance. The heavier airplane will have the greater mass to decelerate but the greater normal force will provide a greater retarding friction force. As a result, both airplanes would have identical acceleration and identical stop distances from a given velocity. However, the heavier airplane would have a greater kinetic energy to be dissipated by the brakes and the principal difference between the two airplanes as they reach a stop would be that the heavier airplane would have the hotter brakes. Therefore, one of the factors of braking performance is the ability of the brakes to dissipate energy without developing excessive temperatures and losing effectiveness.

To appreciate the effectiveness of modern brakes, a 30,000-lb aircraft landing at 175 knots has a kinetic energy of 41 million ft.-lbs. at the instant of touchdown. In a minimum distance landing, the brakes must dissipate most of this kinetic energy and each brake must absorb an input power of approximately 1,200 h.p. for 25 seconds. Such requirements for brakes are extreme but the example serves to illustrate the problems of brakes for high performance airplanes.

While a 10 percent increase in landing weight causes:

a 5 percent higher landing speed

a 10 percent greater landing distance,

it also produces a 21 percent increase in the kinetic energy of the airplane to be dissipated during the landing roll. Hence, high landing weights may approach the energy dissipating capability of the brakes.

The effect of wind on landing distance is large and deserves proper consideration when predicting landing distance. Since the airplane will land at a particular airspeed independent of the wind, the principal effect of wind on landing distance is due to the change in the ground velocity at which the airplane touches down. The effect of wind on acceleration during the landing distance is identical to the effect on takeoff distance and is approximated by the following relationship:

$$\frac{S_2}{S_1} = \left[1 - \frac{V_w}{V_1} \right]^2 \quad (5)$$

where

S_1 = zero wind landing distance

S_2 = landing distance into a headwind

V_w = headwind velocity

V_1 = landing ground velocity with zero wind or, simply, the landing
airspeed

As a result of this relationship, a headwind which is 10 percent of the landing airspeed will reduce the landing distance 19 percent but a tailwind (or negative headwind) which is 10 percent of the landing speed will increase the landing distance 21 percent. Figure 6B-2 illustrates this general effect.

The effect of runway slope on landing distance is due to the component of weight along the inclined path of the airplane. The relationship is identical to the case of takeoff performance but the magnitude of the effect

is not as great. While account must be made for the effect, the ordinary values of runway slope do not contribute a large effect on landing distance. For this reason, the selection of the landing runway will ordinarily favor the direction with a downslope and headwind rather than an upslope and tailwind.

The effect of pressure altitude and ambient temperature is to define density altitude and its effect on landing performance. An increase in density altitude will increase the landing velocity but will not alter the net retarding force. If a given weight and configuration of airplane is taken to altitude above standard sea level, the airplane will still require the same q to provide lift equal to weight at the landing C_L . Thus, the airplane at altitude will land at the same equivalent airspeed (EAS) as at sea level but, because of the reduced density, the true airspeed (TAS) will be greater. The relationship between true airspeed and equivalent airspeed is as follows:

$$\frac{TAS}{EAS} = \frac{1}{\sqrt{\sigma}} \quad (6)$$

where

TAS = true airspeed

EAS = equivalent airspeed

= altitude density ratio

Since the airplane lands at altitude with the same weight and dynamic pressure, the drag and braking friction throughout the landing roll have the same values as at sea level. As long as the condition is within the capability of the brakes, the net retarding force is unchanged and the acceleration is the same as with the landing at sea level.

To evaluate the effect of density altitude on landing distance, the following relationships are used:

since an increase in altitude does not alter acceleration, the effect would be due to the greater TAS

$$\frac{S_2}{S_1} = \frac{(V_2)^2}{(V_1)^2} \times \frac{a_1}{a_2} \quad (7)$$

$$\frac{S_2}{S_1} = \frac{1}{\sigma}$$

where

S_1 = standard sea level landing distance

S_2 = landing distance at altitude

σ = altitude density ratio

From this relationship, the minimum landing distance at 5,000 ft. ($\sigma = 0.8617$) would be 16 percent greater than the minimum landing distance at sea level. The approximate increase in landing distance with altitude is approximately 3-1/2 percent for each 1,000 ft. of altitude. Proper accounting of density altitude is necessary to accurately predict landing distance.

The effect of proper landing velocity is important when runway lengths and landing distances are critical. The landing speeds specified in the flight handbook are generally the minimum safe speeds at which the airplane can be landed. Any attempt to land at below the specified speed may mean that the airplane may stall, be difficult to control, or develop high rates of descent. On the other hand, an excessive speed at landing may improve the controllability (especially in crosswinds) but will cause an undesirable

increase in landing distance. The principal effect of excess landing speed is described by:

$$\frac{S_2}{S_1} = \frac{(V_2)^2}{(V_1)^2} \quad (8)$$

Thus, a 10 percent excess landing speed would cause a 21 percent increase in landing distance. The excess speed places a greater working load on the brakes because of the additional kinetic energy to be dissipated. Also, the additional speed causes increased drag and lift in the normal ground attitude and the increased lift will reduce the normal force on the braking surfaces. The acceleration during this range of speed immediately after touchdown may suffer and it will be more likely that a tire can be blown out from braking at this point. As a result, 10 percent excess landing speed will cause at least 21 percent greater landing distance.

The most critical conditions of landing performance are the result of some combination of high gross weight, density altitude, and unfavorable wind. These conditions produce the greatest landing distance and provide critical levels of energy dissipation required of the brakes. In all cases, it is necessary to make an accurate prediction of minimum landing distance to compare with the available runway. A polished, professional landing technique is necessary because the landing phase of flight accounts for more pilot caused aircraft accidents than any other single phase of flight.

In the prediction of minimum landing distance from the handbook data, the following considerations must be given:

- (1) Pressure altitude and temperature - to define the effect of density altitude.

- (2) Gross weight - which define the CAS or EAS for landing.
- (3) Wind - a large effect due to wind or wind component along the runway.
- (4) Runway slope - a relatively small correction for ordinary values of runway slope.

SUPPLEMENTARY PROBLEMS

Unit 6

1. For an aircraft whose acceleration is not a constant, but very nearly so, it is sometimes the custom to evaluate the net accelerating force at a point mid-distance between the start of take-off and the point where the lift just equals the weight ($V = V_{TO}$). If the thrust, rolling friction and drag are expressed as a function of velocity, at what velocity should these parameters be evaluated in order to determine the net accelerating force?
2. For a no-wind condition it has been computed that an aircraft requires 4,500 feet for take-off. What is the required take-off distance if there is a headwind equal to 15% of the velocity required for take-off?
3. An aircraft requires an air speed of 102 knots for take-off on a no-wind day. What is the velocity required for take-off if there is a direct tail wind of 16 knots?
4. You are making an instrument approach down a 3° glide slope. Is your rate of descent faster, the same or slower if you have a headwind as compared with the no-wind approach?
5. An aircraft touches down ($L = W$) at a velocity of 116 knots. The brakes are applied immediately and produce a coefficient of braking friction of 0.60 (the retarding force due to braking friction is equal to 60 percent of the net load on the wheels). The drag at touchdown is exactly equal to the braking friction just prior to stop. What is the landing distance for this aircraft?

SUPPLEMENTARY PROBLEMS

SOLUTION SHEET

UNIT 6

1. If the acceleration is nearly a constant, the take-off distance (S) is proportional to the square of the take-off velocity (V_{TO}^2). For $S_{average} = s/2$, the 'average' velocity may be computed from:

$$\frac{S}{S/2} = \frac{(V_{TO})^2}{(V_{av})^2}$$

or
$$V_{av}^2 = \frac{1}{2} \cdot (V_{TO})^2$$

and
$$\underline{V_{av} = 0.707 V_{TO}}$$

2. $V_W = 0.15 V_{TO}$ (Statement of the problem)

since

$$\frac{S_2}{S_1} = \left(1 - \frac{V_W}{V_{TO}}\right)^2 \quad \text{from Eq. (10), 6-A where } V_1 = V_{TO}$$

$$S_2 = 4,500 \cdot (1 - 0.15)^2 = 4,500 \cdot (.85)^2$$

$$\underline{S_2 = 3,251 \text{ feet}}$$

3. The velocity required for take-off is a constant, no matter what is the tailwind or headwind. The effect of the wind is only to change the required take-off distance. Therefore,

$$\underline{V_{TO_{wind}} = V_{TO_{no-wind}} = 102 \text{ knots}}$$

4. An intuitive solution to this problem might be had by observing the track of the aircraft under the two wind conditions, considering that the intercept with the glideslope is at the same vertical and horizontal distance from the touchdown point, and that the aircraft velocity on the glideslope is the same in both cases. In both cases the aircraft actually traverses the same glide path, but in the headwind case, the aircraft is "blown back" on to the glideslope. It can be seen that the aircraft flying into the headwind is in the air for a longer time, and must therefore have a slower rate of descent. (Continued).

SUPPLEMENTARY PROBLEMS

SOLUTION SHEET

UNIT 6

(Cont)

4. (Continued)

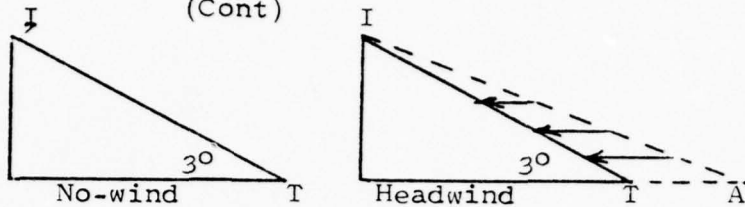

In both cases, the path from the intercept (I) to the touchdown (T) is the same, but in the headwind case, the aircraft is effectively flying from the intercept to the aim point (A).

For a more rigorous solution, let us assume some numerical values. Let the aircraft intercept the glideslope 1,000 feet above the point of touchdown with a glideslope velocity of 100 knots (168.89 ft/sec). From this,

$$\begin{aligned} \text{Horizontal distance from (I) to (T)} &= 1,000 / \tan 3^\circ \text{ ft} \\ &= 19,081 \text{ ft} \end{aligned}$$

Horizontal velocity component (Ground speed)

$$V_h = 168.89 \cos 3^\circ \text{ ft/sec} = 168.66 \text{ ft/sec} = V_{GS}$$

Vertical velocity component (Rate of Sink)

$$V_v = 168.89 \sin 3^\circ \text{ ft/sec} = 8.84 \text{ ft/sec} = 530 \text{ ft/min}$$

The time to fly from intercept to touchdown is the ground distance divided by the Ground speed, or the air height divided by the Rate of Sink:

$$\frac{19,081 \text{ ft}}{168.66 \text{ fps}} = \frac{1,000 \text{ ft}}{8.84 \text{ fps}} = 113 \text{ sec.}$$

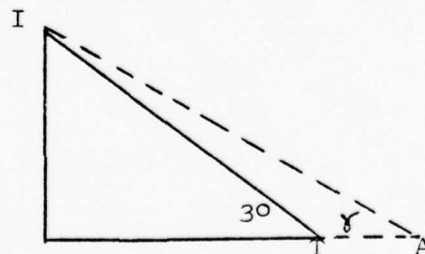

In the headwind case the time to descend is given by

$$t = \frac{\text{Height}}{\text{Modified sink rate}} = \frac{1,000 \text{ ft}}{168.89 \sin \gamma \text{ ft/sec}}$$

but, inasmuch as the angle γ is very small, $\sin \gamma \approx \gamma$, and

$$t = 5.92 / \gamma$$

SUPPLEMENTARY PROBLEMS

SOLUTION SHEET

UNIT 6

(Cont)

4. (Continued)

The time for the ground run is the same as the time for descent

$$t = \frac{19,081 + V_W \cdot t}{168.89 \cos \gamma} = \frac{19,081 + V_W(5.92/)}{168.89 \cos \gamma}$$

Since, for small angles $\cos \gamma \cong 1$,

$$\frac{19,081 + V_W(5.92/\gamma)}{168.89} = t = 5.92/$$

If a headwind of 15 knots is assumed, solving for

$$\gamma = \frac{1,000 - 88.8}{19,081} \text{ radians} = \frac{1,000 - 88.8}{19,081} \times 57.3 \text{ degrees}$$

$$\gamma = 2.74^\circ$$

The rate of descent, in headwind, is therefore $168.89 \sin 2.74$ feet/sec or 484 fpm. In the no-wind case it was shown to be 530 fpm. Therefore a slower rate of sink on a glideslope with headwind.

5. The drag has its highest value at touchdown and decreases as the square of the velocity to zero at stop. The braking friction is zero at touchdown (no net force on the wheels) and increases as the square of the velocity until it is a maximum just prior to stop. If the maximum drag equals the maximum braking force, and both vary as the square of the velocity, the net retarding force is a constant, equal to the maximum braking force:

$$F_R = 0.60 \cdot W = ma = \frac{W}{g} a$$

and $a = 0.60 g$

This means that the acceleration to the rear (Deceleration) is equal to 0.60 times the acceleration due to gravity.

$$S = \frac{v^2}{2a} = \frac{(116 \times 1.6889 \text{ ft/sec})^2}{2 \times (0.60 \times 32.2) \text{ ft/sec}^2}$$

$$S = 993 \text{ ft}$$

APPENDIX I
AERODYNAMIC DATA

STANDARD ATMOSPHERE TABLES

Sea Level Values

Pressure: 14.7 psi, 2116.22 psf, 29.92 in Hg, 1013 mb

Temperature: 59°F 15°C 518.688° Rankine 288.16° Kelvin

Density: .0023769 slugs/cubic ft.

Sonic Velocity: 661.48 kt, 1116.89 fps

Gravitational Acceleration: 32.174 ft/sec/sec

Temperature lapse rate to 36,089 ft:

-3.57°F per 1000 ft, -1.98°C per 1000 ft.

Sonic velocity: $a = a_{s1} \sqrt{\frac{T}{T_{s1}}}$

Tropopause - at 36,089 ft geopotential altitude, T = 216.66° K

Density Ratio $\sigma = \frac{\rho}{\rho_{s1}}$

Temperature Ratio $\theta = \frac{T}{T_{s1}}$

Pressure Ratio $\delta = \frac{P}{P_{s1}}$

Viscosity Ratio $\phi = \frac{\mu}{\mu_{s1}}$

Gas Constant R = 1716.55 ft²/sec² R

Appendix I

TABLE 1
GEOPOTENTIAL AND GEOMETRIC ALTITUDES

Geometric h (Feet)	Geopotential H (Feet)
0	0
10,000	9,995
20,000	19,981
30,000	29,957
40,000	39,923
50,000	49,880
60,000	59,828
70,000	69,766
80,000	79,694
90,000	80,613
100,000	99,523
150,000	148,929
200,000	198,100

TABLE 2

ICAO STANDARD ATMOSPHERE

H (Geopotential Feet)	δ	θ	σ	a (Knots)
0	1.0000	1.0000	1.0000	661.48
500	.9820	.9966	.9854	660.36
1,000	.9643	.9931	.9710	659.23
1,500	.9469	.9897	.9568	658.04
2,000	.9298	.9862	.9427	656.92
2,500	.9129	.9828	.9288	655.79
3,000	.8962	.9794	.9151	654.59
3,500	.8798	.9759	.9015	653.47
4,000	.8636	.9725	.8880	652.34
4,500	.8477	.9691	.8748	651.15
5,000	.8320	.9656	.8616	650.03
5,500	.8166	.9622	.8487	648.84
6,000	.8013	.9587	.8358	647.71
6,500	.7863	.9553	.8231	646.52
7,000	.7716	.9519	.8106	645.34
7,500	.7570	.9484	.7982	644.22
8,000	.7427	.9450	.7860	643.03
8,500	.7286	.9416	.7739	641.34
9,000	.7148	.9301	.7619	640.72
9,500	.7011	.9347	.7501	639.52
10,000	.6877	.9312	.7384	638.31
10,500	.6744	.9278	.7269	637.17
11,000	.6614	.9244	.7155	635.94
11,500	.6486	.9209	.7043	634.82
12,000	.6359	.9175	.6931	633.63
12,500	.6235	.9141	.6821	632.44
13,000	.6113	.9106	.6713	631.25
13,500	.5992	.9072	.6606	630.06
14,000	.5874	.9037	.6500	620.87
14,500	.5758	.9003	.6395	627.61

TABLE 2
(Cont)

(Geopotential Feet)	δ	θ	σ	a (Knots)
15,000	.5643	.8969	.6292	626.42
15,500	.5530	.8934	.6190	625.23
16,000	.5419	.8900	.6089	624.04
16,500	.5310	.8866	.5990	622.84
17,000	.5203	.8831	.5891	621.58
17,500	.5097	.8797	.5794	620.39
18,000	.4993	.8762	.5699	619.21
18,500	.4891	.8728	.5604	617.96
19,000	.4791	.8694	.5511	616.77
19,500	.4692	.8659	.5419	615.58
20,000	.4595	.8625	.5328	614.32
20,500	.4500	.8591	.5238	613.13
21,000	.4406	.8556	.5149	611.87
21,500	.4313	.8522	.5062	610.62
22,000	.4223	.8487	.4975	609.43
22,500	.4134	.8493	.4890	608.17
23,000	.4045	.8419	.4806	606.90
23,500	.3960	.8304	.4723	605.71
24,000	.3875	.8350	.4641	604.46
24,500	.3792	.8316	.4560	603.20
25,000	.3710	.8281	.4481	601.94
25,500	.3630	.8247	.4402	600.96
26,000	.3551	.8212	.4324	599.43
26,500	.3474	.8178	.4248	598.17
27,000	.3398	.8144	.4173	596.92
27,500	.3323	.8109	.4098	595.66
28,000	.3250	.8075	.4025	594.40
28,500	.3178	.8041	.3952	593.15
29,000	.3107	.8006	.3881	591.89
29,500	.3037	.7972	.3810	590.56

TABLE 2
(Cont)

H (Geopotential Feet)	δ	θ	σ	a (Knots)
30,000	.2969	.7937	.3741	589.30
30,500	.2902	.7903	.3672	588.06
31,000	.2836	.7869	.3605	586.80
31,500	.2772	.7834	.3538	585.48
32,000	.2709	.7800	.3473	584.22
32,500	.2646	.7766	.3408	582.90
33,000	.2585	.7731	.3344	581.64
33,500	.2525	.7697	.3281	580.32
34,000	.2467	.7662	.3219	579.06
34,500	.2409	.7628	.3158	577.74
35,000	.2353	.7594	.3098	576.42
35,500	.2297	.7559	.3039	575.09
36,000	.2243	.7525	.2981	573.84
36,089	.2233	.7519	.2970	573.58
40,000	.1851	.7519	.2461	573.58
45,000	.1455	.7519	.1936	573.58
50,000	.1145	.7519	.1522	573.58
55,000	.0900	.7519	.1197	573.58
60,000	.0708	.7519	.0941	573.58
65,000	.0557	.7519	.0747	573.58

TABLE 3
ICAO STANDARD ATMOSPHERE

h	T	P	ρ	a
feet	$^{\circ}\text{R}$	lb/ft ²	lb sec ² /ft ⁴	ft/sec
0	518.688	2116.22	0.0023769	1116.89
500	516.905	2078.26	0.0023423	1114.97
1,000	515.122	2040.85	0.0023081	1113.05
1,500	513.339	2003.99	0.0022743	1111.12
2,000	511.556	1967.68	0.0022409	1109.19
2,500	509.773	1931.89	0.0022078	1107.25
3,000	507.990	1896.64	0.0021752	1105.31
3,500	506.206	1861.91	0.0021429	1103.37
4,000	504.423	1827.69	0.0021109	1101.43
4,500	502.640	1793.99	0.0020793	1099.48
5,000	500.857	1760.79	0.0020481	1097.53
5,500	499.074	1728.09	0.0020173	2095.57
6,000	497.291	1685.89	0.0019868	1093.61
6,500	495.508	1664.17	0.0019566	1091.65
7,000	493.725	1632.93	0.0019268	1089.68
7,500	491.942	1062.17	0.0018974	1087.71
8,000	490.159	1571.83	0.0018683	1085.74
8,500	488.376	1542.06	0.0018395	1083.76
9,000	486.593	1512.70	0.0018111	1081.78
9,500	484.809	1483.79	0.0017830	1079.80
10,000	483.026	1455.33	0.0017553	1077.81
10,500	481.243	1427.31	0.0017279	1075.82
11,000	479.460	1399.73	0.0027008	1073.83
11,500	477.677	1372.59	0.0016740	1071.83
12,000	475.894	1345.87	0.0016476	1069.83
12,500	474.111	1319.58	0.0016215	1067.82
13,000	472.328	1293.70	0.0015957	1065.81
13,500	470.545	1268.23	0.0015702	1063.80
14,000	468.762	1243.18	0.0015451	1061.78
14,500	466.979	1218.52	0.0015202	1059.76

TABLE 3

(cont)

H	T	P	ρ	a
feet	$^{\circ}\text{R}$	lb/ft ²	lb sec ² /ft ⁴	ft/sec
15,000	465.196	1194.27	0.0014956	1057.73
15,500	463.413	1170.40	0.0014714	1055.70
16,000	461.629	1146.92	0.0014474	1053.67
16,500	459.846	1123.83	0.0014238	1051.63
17,000	458.063	1101.11	0.0014005	1049.59
17,500	456.280	1078.77	0.0013774	1047.55
18,000	454.497	1058.80	0.0013546	1045.50
18,500	452.714	1035.18	0.0013322	1043.45
19,000	450.931	1013.93	0.0013100	1041.39
19,500	449.148	993.04	0.0012881	1039.33
20,000	447.365	972.49	0.0012664	1037.26
20,500	445.582	952.29	0.0012451	1035.19
21,000	443.779	932.43	0.0012240	1033.12
21,500	442.016	912.91	0.0012032	1031.04
22,000	440.232	893.72	0.0011827	1028.96
22,500	438.449	874.85	0.0011625	1026.88
23,000	436.666	856.31	0.0011425	1024.79
23,500	434.883	838.09	0.0011227	1022.69
24,000	433.100	820.19	0.0011033	1020.59
24,500	431.317	802.60	0.0010841	1018.49
25,000	429.534	785.31	0.0010651	1016.38
25,500	427.751	768.32	0.0010464	1014.27
26,000	425.968	751.64	0.0010280	1012.15
26,500	424.185	735.25	0.0010098	1010.03
27,000	422.402	719.15	0.0009919	1007.91
27,500	420.619	703.33	0.0009742	1005.78
28,000	418.836	687.80	0.0009567	1003.64
28,500	417.052	672.55	0.0009395	1001.51
29,000	415.269	657.75	0.0009225	999.36
29,500	413.486	642.87	0.0009058	997.22

TABL R 3

(Cont)

H	T	P	ρ	a
feet	θ_R	lb/ft ²	lb sec ² /ft ⁴	ft/sec
30,000	411.703	628.43	0.0008893	995.06
30,500	409.920	614.26	0.0008730	992.91
31,000	408.137	600.34	0.0008570	990.74
31,500	406.354	586.68	0.0008411	988.58
32,000	404.571	573.28	0.0008255	986.41
32,500	402.788	560.12	0.0008102	984.23
33,000	401.005	547.21	0.0007950	982.05
33,500	399.222	535.54	0.0007801	979.86
34,000	397.439	522.11	0.0007653	977.67
34,500	395.656	509.92	0.0007508	975.48
35,000	393.872	497.96	0.0007365	973.28
35,500	392.089	486.22	0.0007225	971.07
36,000	390.306	474.71	0.0007086	968.86
36,089	389.988	472.68	0.0007061	968.47
40,000	389.988	391.68	0.0005851	968.47
45,000	389.988	308.01	0.0004601	968.47
50,000	389.988	242.21	0.0003618	968.47
55,000	389.988	190.47	0.0002845	968.47
60,000	389.988	149.78	0.0002238	968.47
65,000	389.988	117.79	0.0001760	968.47

TABLE 4

U.S. STANDARD ATMOSPHERE SUPPLEMENTS, 1966
Mid-latitude Spring/Fall

H (Geopotential Foot)	δ	θ	σ
0	1.0000	1.0000	1.0000
10,000	.6877	.9312	.7384
20,000	.4595	.8625	.5328
30,000	.2969	.7937	.3745
40,000	.1851	.7519	.2471
50,000	.1145	.7519	.1530
60,000	.0557	.7519	.0949
70,000	.0443	.7563	.0586
80,000	.0277	.7667	.0361
90,000	.0174	.7773	.0153
100,000	.00011	.7877	.0140
150,000	.000013	.9237	.0015
200,000	.000002	.8811	.0002

AE 2305/2306

PERFORMANCE
APPENDIX II
DIMENSIONAL ANALYSIS

DIMENSIONAL ANALYSIS

Often in the study of equations in aircraft performance, an enormous simplification results if we are able to reform the equations in terms of dimensionless quantities. A dimensional analysis proves to be helpful for this problem. Since both terms in a physical equation must have the same dimensions, we may write any equation in a dimensionless form by dividing each side of the equation by a quantity which has the dimensions of the original equation. The Buckingham Pi Theorem states this fact and tells how many dimensionless groups are important:

"If a physical equation exists between n quantities, it may be expressed equivalently as an equation between $n-k$ dimensionless groups (π groups) of these quantities, where k is less than or equal to the number of independent dimensions involved in the n quantities."

Determining the proper n quantities for any physical problem formulation is a matter of intuitive reasoning, experimental knowledge of the important parameters or outright postulation of the form of the equation. The resulting π groups only insure that the equation is dimensionally homogeneous and do not insure that it satisfies the basic laws governing the physical problem for which the equation is to be applied. We wish to derive the π groups applicable to the equation governing the resultant aerodynamic force.

We may write

$$f_1(A, B, C, D, E, F, G, \dots) = 0$$

or using the theorem

$$f_2(\pi_1, \pi_2, \dots, \pi_{n-k}) = 0$$

Each dimensionless π group has the form

$$\pi_i = \frac{abcdefg}{ABCDEFG}$$

where a through g are as yet unknown constant exponents. Usually the independent dimensions are force, length and time so we may expect, in this case, four (7-3) dimensionless π groups in the equation for resultant force.

Substituting force, length, and time into the π expressions for A, B, C, D, E, F, G and then using the fact that in order for the π expressions to be dimensionless, the sum of the resulting exponents must be zero, algebraic equations using the resultant exponents may be solved. In order to clarify the above principles of Dimensional Analysis, consider the following example:

DIMENSIONAL ANALYSIS OF
AIRPLANE DRAG

A consideration of all the variables that normally affect the aerodynamic drag of an airplane in level flight produces the following

$$D = f \left(\underbrace{P, \rho, \mu}_{\text{Fluid Properties}}, \underbrace{V, S, W}_{\text{Airplane Properties}} \right)$$

The above statement is based on what is known (based on experience) to effect the drag in level flight. The dimensional analysis that follows will yield a more compact statement of the above and permit us to generalize drag data.

The dimensional analysis is accomplished by the procedure described below:

- (1) Let n = number of variables - ($n=7$ the dependent variable Drag (D) plus six independent variables (P, ρ , μ , V, S, W))
- (2) Let k = number of dimensions describing the above variables - ($k=3$) Mass, length and time

(3) List the dimensions of each of the variables

<u>Variable</u>	<u>Dimension</u>	<u>MLT Dimention</u>
D (drag)	lbs	MLT^{-2}
P (Pressure)	lbs/ft ²	$ML^{-1}T^{-2}$
S (area)	ft ²	L^2
V (velocity)	ft/sec	LT^{-1}
μ (viscosity)	slug/ft-sec	$ML^{-1}T^{-1}$
ρ (density)	slug/ft ³	ML^{-3}
W (weight)	lbs	MLT^{-2}

The rules of dimensional analysis state that 4 (n-k) dimensionless groups ($\pi_1, \pi_2, \pi_3, \pi_4$) can be formed and that the following can be stated

$$f(\pi_1, \pi_2, \pi_3, \pi_4) = 0$$

or

$$\pi_1 = f(\pi_2, \pi_3, \pi_4)$$

or

$$\pi_2 = f(\pi_1, \pi_3, \pi_4)$$

etc.

The problem now is to define the above groups.

- a. First, pick the four (n-k) primary variables. In a general problem any variables can be selected; however, in our problem we will specify the four to be picked since we want to get the final result in a specific form. The primary variables are identified by a dot.

$$\dot{D} = f(P, \rho, \dot{\mu}, \dot{V}, S, \dot{W})$$

- b. In general, each dimensionless group is made up of a primary variable and the remaining "unassigned" variables. For our example, the groups

are

$$\pi_1 = (D P^{a_1} S^{b_1} \rho^{c_1})$$

$$\pi_2 = (W P^{a_2} S^{b_2} \rho^{c_2})$$

$$\pi_3 = (V P^{a_3} S^{b_3} \rho^{c_3})$$

$$\pi_4 = (\mu, P^{a_4} S^{b_4} \rho^{c_4})$$

As shown above the primary variable in each group is assigned an exponent on one. The objective now is to find the exponents (a, b, c) that will make each group dimensionless.

π_1

The first group (π_1) can be written as

$$\pi_1 = \frac{(MLT^{-2})}{D} (ML^{-1}T^{-2})^{a_1} (L^2)^{b_1} (ML^{-3})^{c_1} \rho \quad \text{Equation 1}$$

In order for the above to be dimensionless the combined exponent of each dimension must be zero. Thus, an equation for each dimension (M, L, T) can be written as follows

$$M: 1 + a_1 + 0 b_1 + c_1 = 0$$

$$L: 1 - a_1 = 2 b_1 - 3c_1 = 0$$

$$T: -2 - 2a_1 + 0 b_1 - 0c_1 = 0$$

Solving the above set of equations gives

$$a_1 = -1$$

$$b_1 = -1$$

$$c_1 = 0$$

The above exponents substituted back into equation 1 gives the dimensionless drag group.

$$\pi_1 = \frac{D}{PS}$$

π_2

Since weight (W) and drag (D) have the same dimensions the dimensionless group π_2 will be the same form as π_1 . Thus

$$\pi_2 = \frac{W}{PS}$$

π_3

The group π_3 can be written as

$$\pi_3 = \frac{L T^{-1}}{V} (M L^{-1} T^{-2})^a \frac{L^2}{S} (M L^{-3})^c \quad \text{Equation 2}$$

The equations for M, L and T can be written and solved giving

$$a_3 = -1/2$$

$$b_3 = 0$$

$$c_3 = 1/2$$

Substituting a_3 , b_3 and c_3 back into equation 2 gives

$$\pi_3 = \frac{V}{P} \frac{1/2}{1/2}$$

π_4

The dimensionless group π_4 can be written as

$$\pi_4 = \frac{(M L^{-1} T^{-1})^1}{\mu} (M L^{-1} T^{-2})^a \frac{L^2}{S} (M L^{-3})^c$$

Again, the equation for M, L, and T can be written and solved giving

$$a_4 = - 1/2$$

$$b_4 = - 1/2$$

$$c_4 = - 1/2$$

Thus $\pi_4 = p^{-1/2}, S^{-1/2}, \rho^{-1/2}, \mu$

Each of the four dimensionless groups has been evaluated. They are

$$\pi_1 = D, P^{-1}, S^{-1}$$

$$\pi_2 = W, P^{-1}, S^{-1}$$

$$\pi_3 = V, \rho^{-1/2}, P^{-1/2}$$

$$\pi_4 = P^{-1/2}, S^{-1/2}, \rho^{-1/2}, \mu$$

The dimensional analysis has taken the original statement

$$D = f(P, \rho, \mu, V, S, W)$$

and "reduced" it to the following more compact statement

$$\pi_1 = f(\pi_2, \pi_3, \pi_4)$$

or

$$\frac{D}{PS} = f\left(\frac{W}{PS}, V, \rho^{1/2}, P^{1/2}, \frac{\mu}{P^{1/2} S^{1/2} \rho^{1/2}}\right)$$

We could stop at this point since we have accomplished our main objective of obtaining a dimensionless form of the original drag equation. However, often it is more desirable to reduce the equation further in terms of measurable

quantities that have been corrected to standard day, sea level conditions. We will now express the above groups in terms of more conventional looking variables. The reasoning for the regrouping of variables will become obvious later in the course.

$$\pi_1 = \frac{D}{PS} = K_1 \left(\frac{D}{\delta}\right) \quad \text{where } K_1 = \frac{1}{SP_{ssl}}$$

$$\pi_2 = \frac{W}{PS} = K_2 \left(\frac{W}{\delta}\right) \quad \text{where } K_2 = \frac{1}{SP_{ssl}}$$

$$\pi_3 = \frac{v_D^{1/2}}{p^{1/2}} = K \frac{V}{T^{1/2}} = K_3 (M) \quad \text{where } K_3 = \delta^{1/2}$$

$$\pi_4 = K_4 / RNI \quad \text{where } K_4 = \frac{S^{-1/2} T_{ssl}^{1/2} u_{ssl}}{P_{ssl}}$$

$$\text{and } RNI = \frac{\delta}{\rho v \theta}$$

Our final result is

$$K_1 \frac{D}{\delta} = f(K_3 M, K_2 \frac{W}{\delta}, K_4 RNI)$$

The above results are just as useful if the constant terms are left out thus giving

$$\frac{D}{\delta} = f(M, \frac{W}{\delta}, RNI)$$

The basic drag equation is now in a form that lends itself to measurement utilizing measurable aircraft parameters.

AE 2305/2306
PERFORMANCE
APENDIX III
REVIEW OF MECHANICS

MECHANICS REVIEW

SECTION I

INTRODUCTION

Mechanics is the science which analyzes the effects of forces on the motion and/or shape of bodies. In mechanics, rest may be considered as a special form of motion. In the analysis contained herein the bodies will be considered as being rigid and only the effects of forces on the motion of the body will be considered.

The effect of forces on the shape of bodies is in itself a specialized branch of mechanics usually referred to as Strength of Materials.

Rigid body mechanics may then be divided into the areas of statics and dynamics. In the static case:

- a. ΣF (summation of forces) in any direction is equal to zero.
- b. ΣM (summation of moments) about any axis is equal to zero.
- c. The body will, remain in its state of uniform motion (or rest).

In the dynamic case the summation of the forces and/or moments are not equal to zero and a linear or rotational acceleration (or both) will be manifested in the direction of the imbalance.

UNITS OF MEASUREMENT

In order to adequately describe physical phenomena it is necessary to express these phenomena in terms of physical dimensions or units. In order to compare the physical phenomena of one system with those of another it is necessary to have a standard system of units. Three basic concepts are required to analyze systems of units. They are time, space and mass, and the

units required to measure time, space and mass are called the fundamental units. There are several systems of fundamental units: the kilogram - meter - sec. system, the gram-centimeter-sec. system, and the slug-ft-sec. system.

In this course the slug-ft-sec. system will be used. The slug is defined as the mass of a body that has 32.174 times the mass of a pound mass. The pound mass (lb mass) is the mass of a standard platinum body retained in the standards office in Westminster, London.

A foot is one third of a yard which is 3600/3937 meters. The meter is the distance between two marks on a certain platinum iridium bar at the temperature of melting ice. This bar is retained at the International Bureau of Weights and Measures near Paris. The second is defined as 1/86,400 part of a mean solar day. The mean solar day is the yearly average interval between successive passes of the sun across a meridian.

POUND MASS, POUND FORCE AND WEIGHT

The pound mass has been defined. The pound force is the force required to accelerate a slug mass at the rate of 1 ft/sec^2 . The pound force may also be defined as the gravitational attraction exerted by the earth on a one pound mass at sea level at 45° latitude. At sea level at 45° latitude the acceleration due to the earth's attraction is 32.174 ft/sec^2 , hence the proportionality between the lb mass and the slug.

The gravitational attraction exerted by the earth on a body is inversely proportional to the square of the distance of the body from the center of the earth. The gravitational attraction of the earth is also counterbalanced by the earth's rotation. Table I shows the effect of latitude on the local gravitational acceleration.

TABLE I
Variation of Sea Level Gravitational Acceleration with Latitude

Latitude deg.	Local Gravitational Acceleration - ft/sec ²	Local Gravitational Acceleration/Standard Gravitational Acceleration
0	32.088	0.9973
20	32.108	0.9979
40	32.158	0.9995
45	32.174	1.0000
60	32.215	1.0013
80	32.253	1.0024
90	32.258	1.0026

The decrease in local gravitational acceleration with increase in altitude is approximately 0.003 ft/sec² per thousand ft. Then at 45° latitude at 100,000 ft the gravitational acceleration is 31.874 ft/sec² or approximately one percent less than its value at sea level.

The weight of a body is the gravitational attraction force exerted on the body in its particular locality. At sea level at the standard latitude the weight of the body in pounds is equal to the mass of the body in lbs. Then the weight of the body may be determined by the expression:

$$W = W^* \frac{g}{g_0}$$

where W^* is the weight of the body in pounds at the standard locality, g_0 is 32.174 ft/sec² and g is the local gravitational acceleration. It should be noted that the value of $\frac{W^*}{g_0}$ is the mass of the body in slugs.

OTHER QUANTITIES

From the fundamental units, all other physical quantities may be described. For example, pressure is measured in terms of force per unit area (length squared) and work is measured in terms of force times distance (length).

AXIS SYSTEMS

In order to analyze problems in mechanics it is necessary to describe a system of coordinates to describe the fundamental concept of space. The right-hand orthogonal axis system is shown in figure 1 for free space and for the airplane.

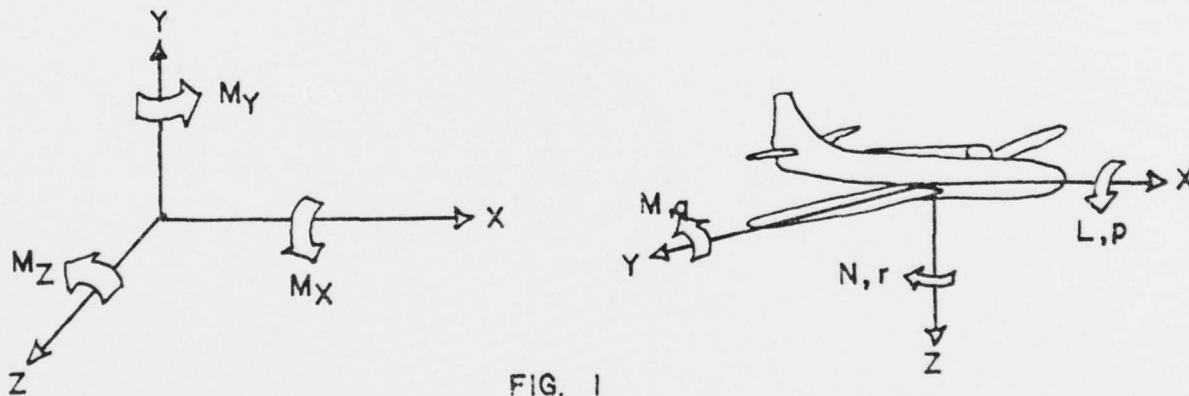

In this axis system, positive linear and rotational quantities and displacements are in the directions as shown. The direction of positive rotational quantities is obtained by orienting the thumb of the right hand in the direction of the axis and observing the curl of the fingers of the right hand.

For the orthogonal system attached to the airplane, L , M and N are the rolling, pitching and yawing moments respectively, and p , q and r are the rolling, pitching and yawing velocities (rates) respectively.

VECTORS

A vector is a quantity having magnitude, direction and a sense of direction. A quantity which does not satisfy these criteria is not a vector and is called a scalar. Examples of vector quantities are forces, distances, velocities, accelerations and moments. Examples of scalar quantities are time, mass, energy and area. In describing a vector one should always include three quantities: magnitude, direction and sense. For example the term "a ten lb force" is meaningless whereas the term "a ten lb force acting to the right at an angle of 30° above the horizon" is meaningful.

Vector systems may be of various types, co-planar, non co-planar, concurrent, non concurrent, co-linear, non co-linear and parallel. Co-planar simply means that all vectors lie in the same plane, con-current means that all vectors have the same line of action and parallel means that all vectors act in the same direction.

VECTOR ADDITION - TWO DIMENSIONAL VECTORS

Consider a man walking in a field starting at the south-west corner. As he moves we could express his path in the field by a series of vectors. For example he could move 20° north of east for 200 ft and north for 100 ft. His ground path is shown in Figure 2.

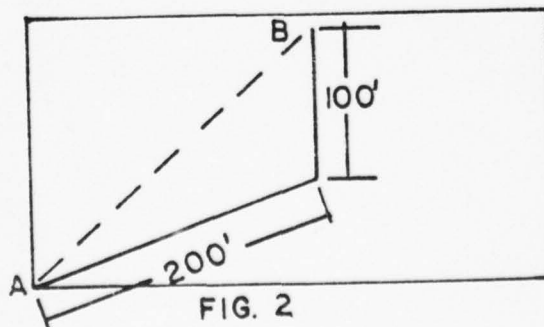

The net effect of the man's walk was to move from point A to point B. The dashed line between A and B in figure 2 is the resultant of the two vectors shown.

The resultant of a vector system has the same overall effect as the individual vectors. The value of the resultant may be determined by several methods.

The first method is by use of the parallelogram law. In this method the vectors are placed "tail to tail" and the parallelogram is completed. The resultant is then as shown in figure 3.

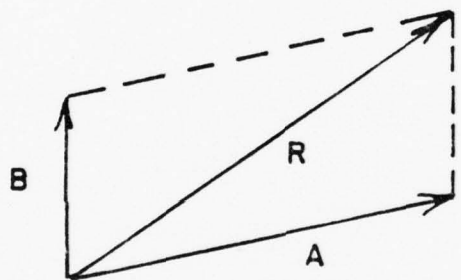

FIG. 3

The same solution might have been obtained by using trigonometric considerations. From the law of cosines:

$$R^2 = A^2 + B^2 - 2AB \cos \theta$$

or from the law of sines:

$$\frac{\sin \alpha}{B} = \frac{\sin \beta}{A} = \frac{\sin (180 - \alpha - \beta)}{R}$$

where the angles and the vectors A, B and R are defined in the Figure 4.

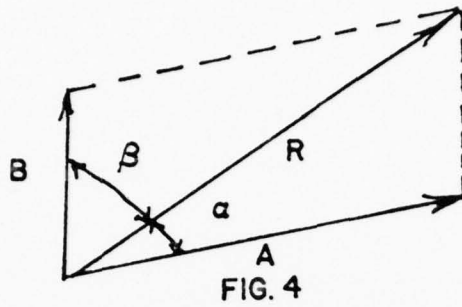

FIG. 4

In the trigonometric solution we have in effect merely placed the vectors "tail to head" and closed the triangle as shown below in Figure 5.

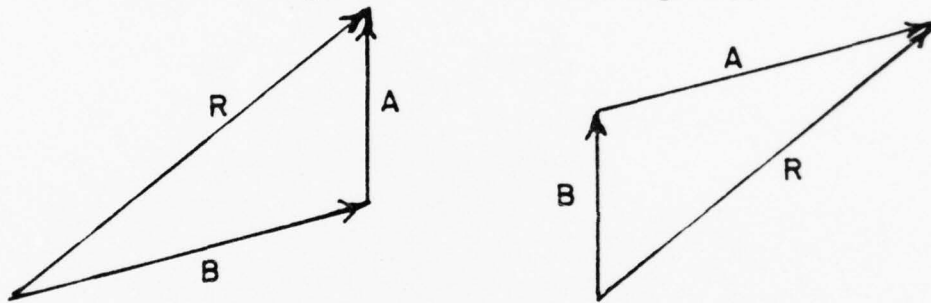

FIG. 5

This closing of the triangle method is applicable to all polygons and the solution obtained is independent of the order of the vectors as shown in Figure 6.

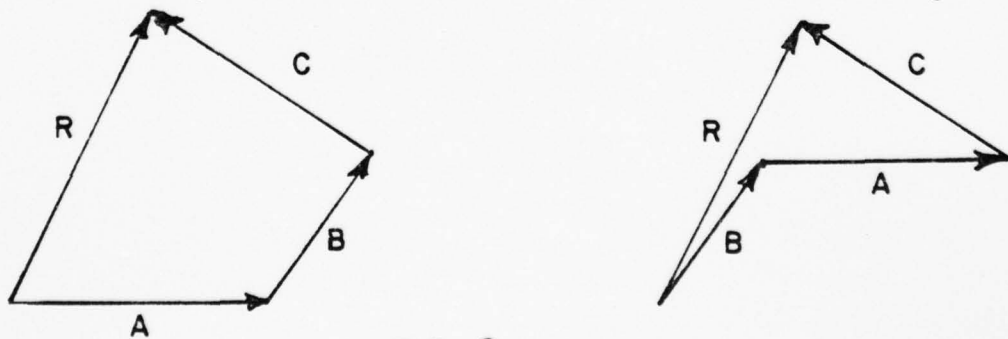

FIG. 6

The fact that the order of the addition of the vectors has not changed their resultant demonstrates the commutative properties of vectors. Quantities which do not possess the commutative properties are not vectors. Angular displacements

have magnitude, direction and sense but are not commutative. Consider for example, an airplane in wings level flight that pitches 90° nose up, rolls 90° right, and yaws 90° right. This airplane's final position is along the initial heading but 90° right wing down. Consider now an airplane in wings level flight which pitches 90° nose up, yaw 90° right and rolls 90° right. This airplane is now on its back on a course perpendicular to the original course.

Probably the most commonly used method of vector addition and the one most used in this course is the resolution of the component vectors into mutually perpendicular components and determination of the resultant by use of the Pythagorean Theorem. Consider the concurrent co-planar vectors A, B and C as shown in Figure 7.

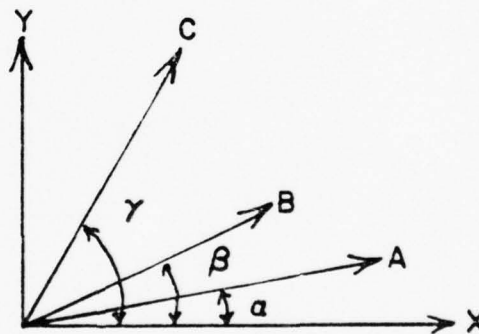

FIG. 7

Each of these vectors has a component in the x and y directions as listed below:

$$A_x = A \cos \alpha$$

$$B_x = B \cos \beta$$

$$C_x = C \cos \alpha$$

$$A_y = A \sin \alpha$$

$$B_y = B \sin \beta$$

$$C_y = C \sin \alpha$$

The resultant of these vectors has components in the x and y directions given by R_x and R_y where:

$$R_x = A_x + B_x + C_x$$

$$R_y = A_y + B_y + C_y$$

Then the resultant R is equal to the square root of the sum of the squares of the components of the resultant.

$$R = \sqrt{R_x^2 + R_y^2}$$

and the angle between the resultant R and the X axis is equal to $\tan^{-1} \frac{R_y}{R_x}$. Figure 8 presents these relationships.

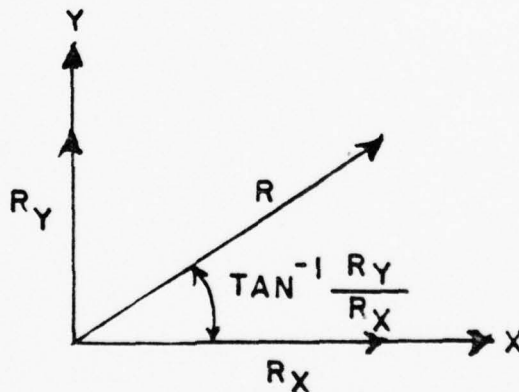

FIG. 8

THREE DIMENSIONAL VECTORS - DIRECTIONS COSINES

In general, vectors in space may be resolved into three mutually perpendicular components. Summation of the components in a given direction of all the vectors to be considered will allow determination of the net effect of all the vectors in that given direction. One method of resolving a three dimensional

vector into mutually perpendicular components is by the method of directional cosines. Consider the three dimensional vector R as depicted in Figure 9.

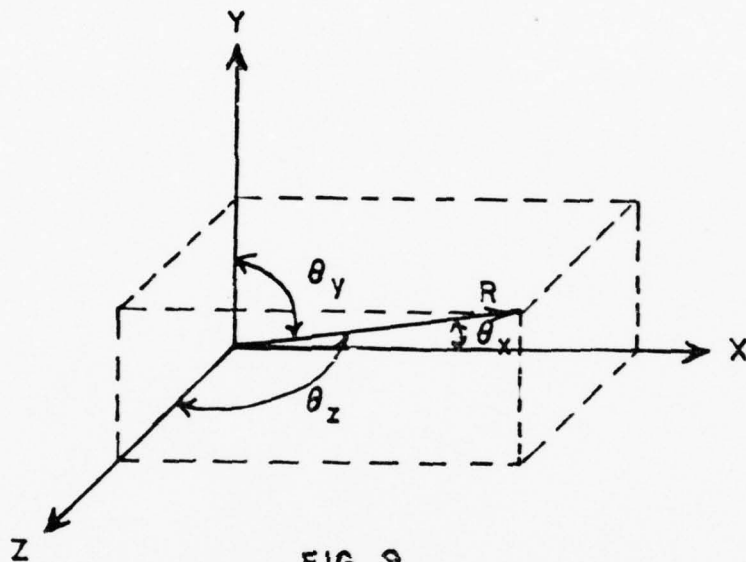

FIG. 9

The angles θ_x , θ_y , and θ_z are the angles between R and the x , y and z axes, respectively, measured in a plane containing R and the respective axis. Then the components of R in the x , y and z directions are:

$$R_x = R \cos \theta_x$$

$$R_y = R \cos \theta_y$$

$$R_z = R \cos \theta_z$$

To demonstrate the validity of the above expressions let us assume the vectors R_x , R_y , and R_z and determine their resultant R . Let us first find the resultant of two vectors lying in a common plane, say the xz plane. This

solution is obtained in Figure 10 where:

$$R_{xz} = \sqrt{R_x^2 + R_z^2}$$

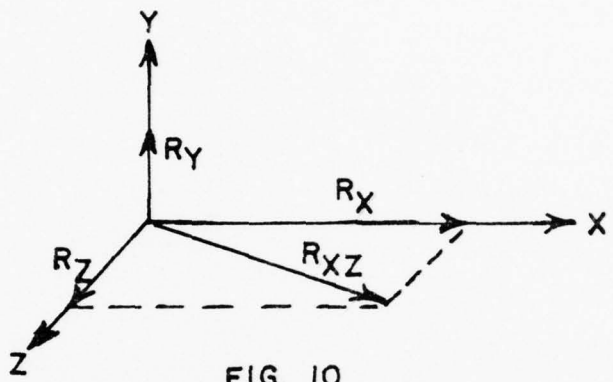

FIG. 10

The vectors R_y and R_{xz} are now in a common plane and they may be resolved into a single vector R . In figure 11 the complete solution is obtained where

$$R = \sqrt{R_y^2 + R_{xz}^2}$$

or by substituting for R_{xz}^2

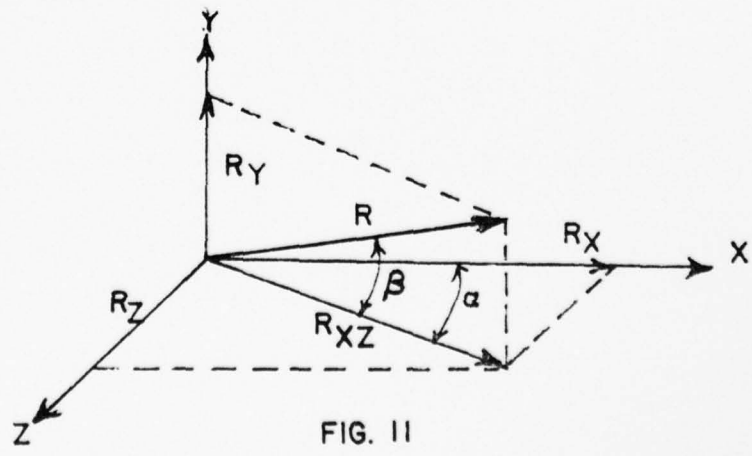

FIG. 11

Then from figure 11 for example:

$$R_x = R_{xz} \cos \alpha$$

$$R_{xz} = R \cos \beta$$

and

$$R_x = R \cos \alpha \cos \beta$$

where $\cos \theta_x = \cos \alpha \cos \beta$

The component in a given direction of any vector is simply the product of the magnitude of the vector times the cosine of the angle between the vector and the desired direction.

SECTION II

EQUILIBRIUM

Newton's first Law of Motion states that:

A body in a state of rest or uniform motion in a straight line will remain in that state unless acted upon by external forces to change that state.

This law merely states that if the magnitude and direction of the velocity of the body are not functions of time then the net external force on the body is zero. If the net external force is zero then the body is in equilibrium.

EQUILIBRIUM FORCE SYSTEMS

The simplest force system is the co-linear system which could be illustrated by a weight being supported by a cable. Figure 1 represents this system and

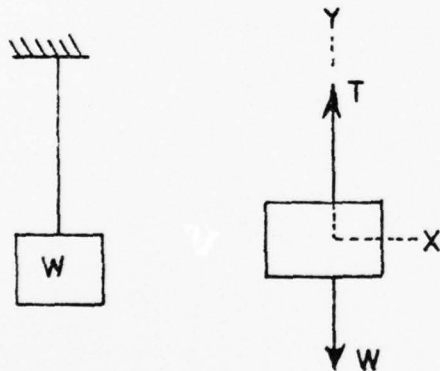

FIG. 1

shows the free body diagram with an axis system superimposed. There are no forces in the x direction. For equilibrium, the net force in the y direction must equal zero. Then we can write the equation:

$$F_y = 0 + \begin{matrix} \text{(assumed position} \\ \text{direction upwards} \end{matrix}$$

then:

$$T - W = 0; \quad T = W$$

Note that to solve the co-linear system only one equation was required.

Consider now a concurrent co-planar force system which might be represented by a weight supported by the two non-vertical cables as shown in Figure 2.

In Figure 2 we might replace the free body diagram by a slightly more simple diagram by realizing that a force may be considered to act at any point along

its line of action. For example a horizontal push on the rear of a wagon has the same effect as a horizontal pull on the tongue of the wagon. The free body diagram for Figure 2 might appear as in Figure 3 with a superimposed axis system. For equilibrium, force balance must now be obtained in both the x and y directions.

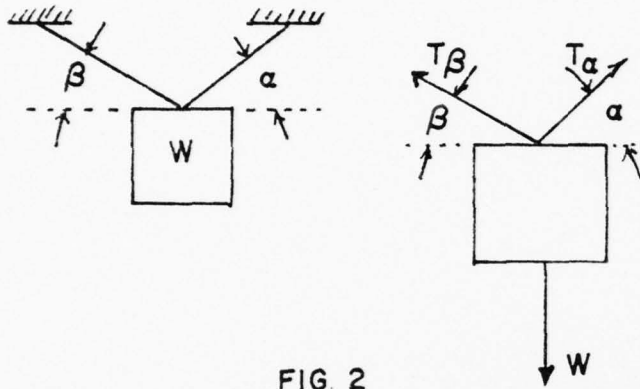

FIG. 2

$$F_x = 0 \rightarrow +$$

$$F_y = 0 \uparrow +$$

Then:

$$T_A \cos \alpha - T_B \cos \beta = 0$$

$$T_A \sin \alpha + T_B \sin \beta - W = 0$$

We now have two simultaneous equations in two unknowns and the values of T_A and T_B may be determined. Only two force equations were required to solve this type of problem.

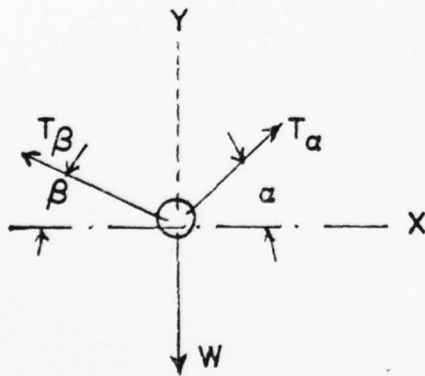

FIG. 3

The next force system to be considered is the parallel force system which might be represented by a beam loaded and supported as in Figure 4. In the free body diagram of Figure 4, there are no forces in the x direction but there are now two unknowns, R_{AY} and R_{BY} , hence two equations are required. The forces in the y direction may be summed to yield

$$F_y = 0 \uparrow \uparrow; \quad R_{AY} + R_{BY} - P = 0$$

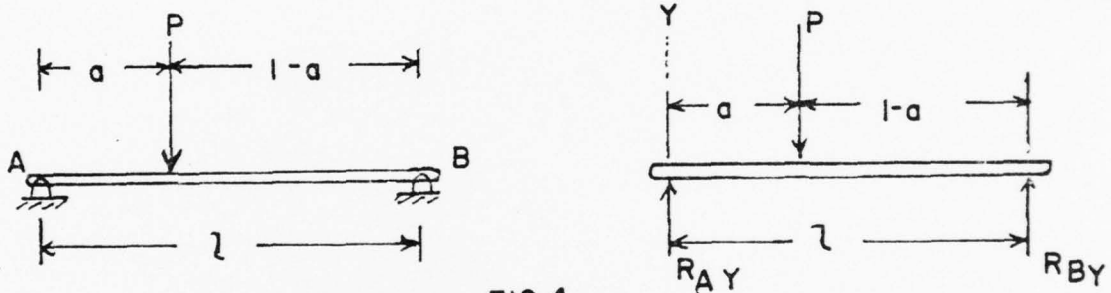

FIG. 4

In addition we must now insure the magnitudes of R_{AY} and R_{BY} are such that one end of the beam will not be lifted, or that there is no unbalanced moment acting on the beam. To do this, we may sum moments about any point and for equilibrium require the net moment to equal zero. For example, let us sum moments first about point A and then about point B and show that either moment equation coupled with the force equation results in the same answer:

$$M_A = 0 \uparrow; \quad R_{BY} \cdot l - P \cdot a = 0$$

Then our two simultaneous equations are:

$$R_{AY} + R_{BY} - P = 0$$

$$R_{BY} \cdot l - P \cdot a = 0$$

Summing moments about B yields

$$M_B = 0 + ; -R_a \cdot l + P (\ell - a) = 0$$

The two simultaneous equations are:

$$R_{A_y} + R_{B_y} -) = 0$$

$$R_{A_y} + P (\ell - a) = 0$$

Solution of either set of simultaneous equations gives:

$$R_{A_y} = \frac{P (\ell - a)}{\ell}$$

$$R_{B_y} = P \frac{(a)}{\ell}$$

Another force system to consider is the non-concurrent, non-parallel, co-planar force system. An example of such a system is shown in Figure 5.

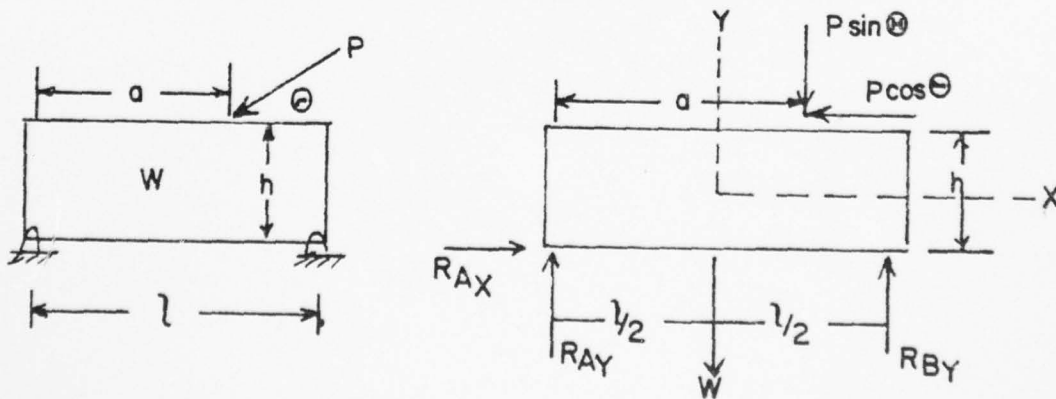

FIG. 5

In this system there are three unknowns, R_{A_x} , R_{A_y} and R_{B_y} , and hence three independent equations are required. For this system we may write:

$$\Sigma F_x = 0 ; R_{A_x} - P \cos \theta = 0$$

$$\Sigma F_y = 0 ; R_{A_y} + R_{B_y} - W - P \sin \theta = 0$$

$$\Sigma M_{\text{ANY point}} = 0 +$$

(e.g. point A) $(P \cos \theta) h - (P \sin \theta) a - W \frac{l}{2} + R_{B_y} l = 0$

Let's pause a few moments and review some of the presented concepts with a few sample problems illustrating their applications.

COUPLES

An interesting force system is the couple. The couple consists of two parallel non co-linear forces equal in magnitude but opposite in direction. Since the forces are parallel a couple must act in a plane. Figure 6 presents a couple.

Since the forces constituting a couple are equal in magnitude and opposite in direction the net force exerted by a couple is zero. The net moment of a couple about any perpendicular axis is a constant.

AD-A039 654

NAVAL POSTGRADUATE SCHOOL MONTEREY CALIF
A PERSONALIZED SYSTEM OF INSTRUCTION FOR AIRCRAFT PERFORMANCE.(U)
MAR 77 D L FINCH

F/G 5/9

UNCLASSIFIED

NL

5 OF 5
ADA
0 39654



END

DATE
FILMED
6-77

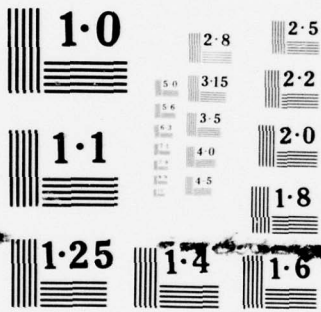

NATIONAL BUREAU OF STANDARDS
MICROCOPY RESOLUTION TEST CHART

SAMPLE PROBLEM # 1:

The airplane weights 16,000 lb, the thrust is 4,800 lb, the climb angle is 10° and the angle of attack is 12° . Determine the aerodynamic force component parallel to the flight path (Drag) and perpendicular to the flight path (Lift).

Thrust is 4,800 lb

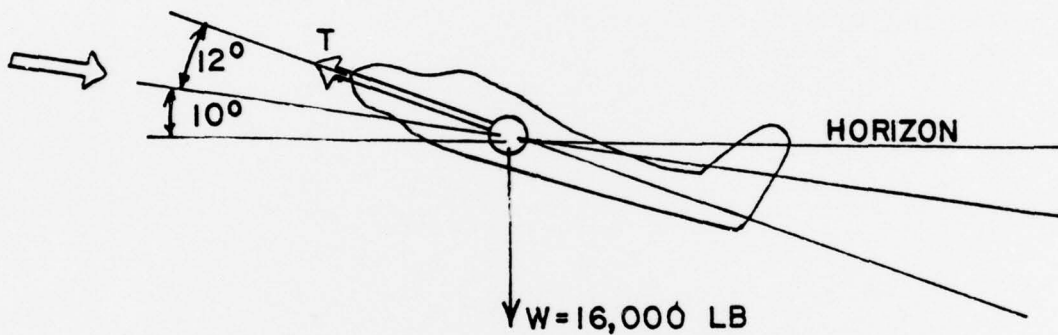

SOLUTION:

$$\begin{aligned} \Sigma F_x &= 0 + \\ -4800 \cos 12 + 16000 \sin 10 + d &= 0 \\ D &= 4800 \cos 12 - 16000 \sin 10 \\ &= 4700 - 2780 \\ D &= 1920 \\ \Sigma F_y &= 0 + \uparrow \\ +4300 \sin 12 - 16000 \cos 10 + L &= 0 \\ L &= 16000 \cos 10 - 4800 \sin 12 \\ &= 15750 - 1000 \\ LL &= 14750 \end{aligned}$$

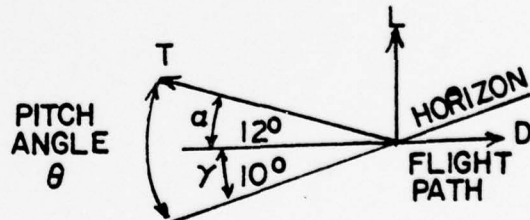

SAMPLE PROBLEM # 2

Determine the landing gear reactions when the airplane is at rest on the runway ready for takeoff.

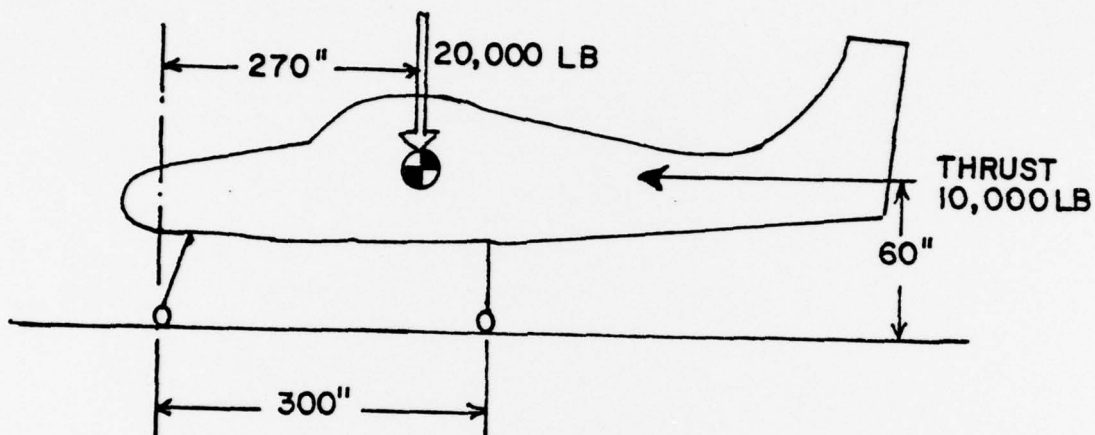

SOLUTION:

Assume $R_{NX} = 0$ (ie, all braking by main landing gear)

$$\Sigma F_y = 0 + \uparrow$$

$$R_{My} + R_{Ny} - 20000 = 0$$

$$R_{My} = 20000 - R_{Ny}$$

$$\Sigma F_x = 0 + \quad (\text{Assume } R_{Nx} = 0)$$

$$R_{Mx} - 10000 = 0$$

$$R_{Mx} = 10000 - B$$

$$M_{CG} = 0 +$$

$$R_{My}(30) - R_{Ny}(270) + R_{Mx}(60) = 0$$

$$(20000 - R_{Ny})(30) - (R_{Ny})(270) + 10000(60) = 0$$

$$R_{Ny} = \frac{(20000)(30) + (10000)(60)}{30 + 270}$$

$$R_{Ny} = \frac{1200000}{300} = 4000 \text{ lb}$$

$$R_{My} = 20000 - R_{Ny} = 16000 \text{ lb}$$

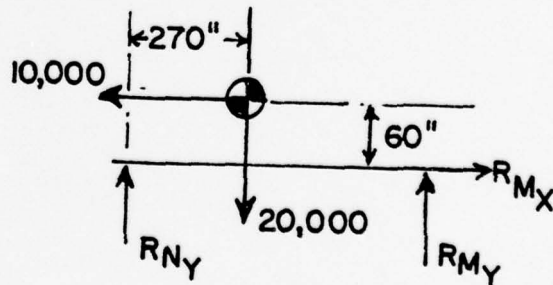

Now let's take the above aircraft and put it on the catapult of a carrier.

SAMPLE PROBLEM # 3:

Determine the landing gear reaction with the system at rest and the horizontal component of the gear reaction is zero. Holdback tension is 15,000 lb.

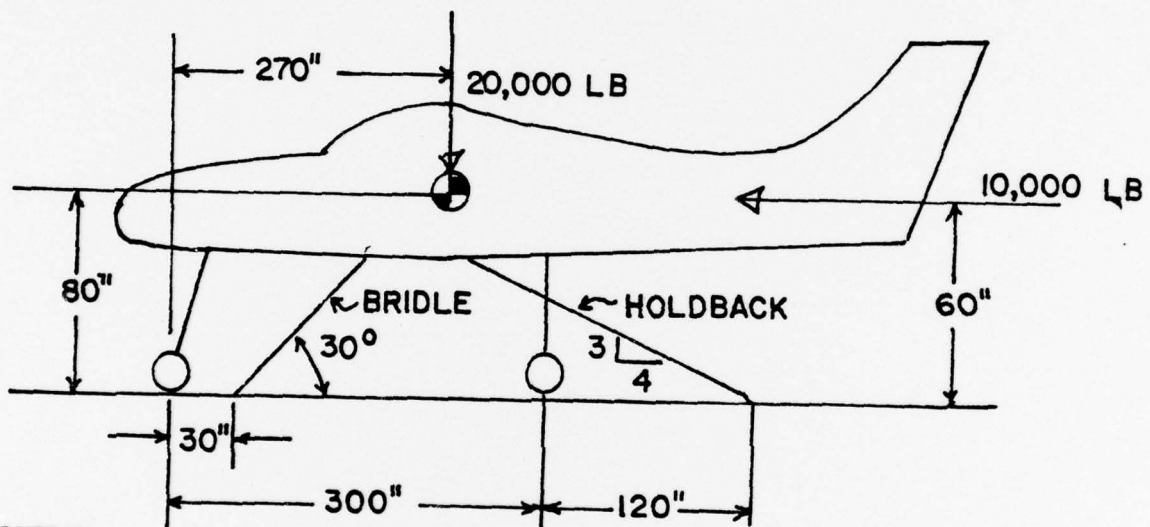

SOLUTION:

$$\text{Assume } R_{Nx} = R_{Mx} = 0$$

$$T_{HB} = 15000$$

$$\Sigma F_x = 0 +$$

$$T_{HB} (4/5) - T_B \cos 30 - 10000 = 0$$

$$\frac{15000(4/5) - 10000}{\cos 30} = T_B$$

$$2130 \text{ lb} = T_B$$

$$\Sigma F_y = 0 + +$$

$$R_{NGy} + R_{MGy} - 20000 - T_B \sin 30 - T_{HB} (3/5) = 0$$

$$R_{NGy} + R_{MGy} = 20000 + 2310(.5) + 15000(3/5) - R_{My}$$

$$R_{Ny} = 30155 - R_{My}$$

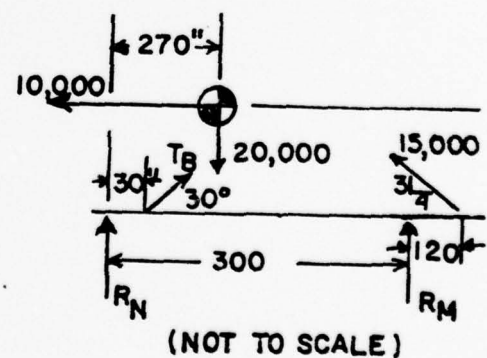

$$M_{CG} = 0^*$$

$$-R_N(270) + TB\sin 30^\circ(240) - TB\cos 30^\circ(60) + R_M(30) - T_{HB}(3/5)(150) + T_{HB}(4/5)(60) = 0$$

$$-(30155 - R_M)(270) + (2310)(.5)(240) - (2310)(.866)(60) + R_M(30) - (1500)(3/5)(150) + (1500)(4/5)(60) = 0$$

$$R_M = - (2310)(.5)(240) + (2310)(.866)(60) + (1500)(3/5)(150) - (1500)(4/5)(60) \\ \times 270 + 30 \\ + \frac{(30155)(270)}{270 + 30}$$

$$R_M = - \frac{277000 + 120000 + 135000 - 72000 + 8140000}{300}$$

$$R_M = \frac{80460}{3} = 26,900 \text{ lb}$$

$$R_N = 30155 - 26900 = 3,255 \text{ lb}$$

COUPLES

An interesting force system is the couple. The couple consists of two parallel non co-linear forces equal in magnitude but opposite in direction. Since the forces are parallel a couple must act in a plane. Figure 6 presents a couple.

Since the forces constituting a couple are equal in magnitude and opposite in direction the net force exerted by the couple is zero. The net moment of a couple about any perpendicular axis is a constant.

Consider the moment exerted about first line ab, then line cd, then line ef.

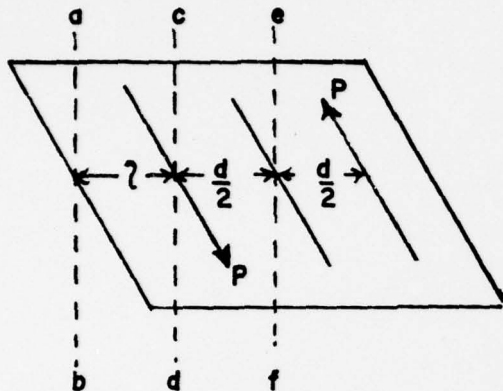

FIG. 6

Line ab

$$M_{ab} + = - P \cdot l + P (d + l) = P \cdot d$$

Line cd

$$M_{cd} + = P \cdot d$$

Line ef

$$M_{ef} + = P(d/2) + P(d/2) = P \cdot d$$

In each case the net moment is equal to the product of P times d , the magnitude of the couple. Thus it is possible to have an infinite number of couples of the same magnitude simply by varying the value of P and d while retaining the values of their product.

A couple may be oriented in any manner in the plane in which it acts without changing its magnitude. Consider the couple of Figure 6, oriented as in Figure 7.

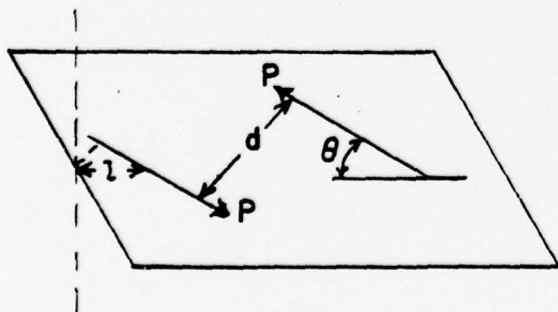

FIG. 7

The moment of this couple about line ab is given by:

$$M_{ab} + = - P l \sin\theta + P (d + l \sin\theta) = Pd$$

Again the moment of the couple is the product P times d .

In summary, a couple may be transformed in the following ways without altering the characteristics of the couple:

- (1) Rotation of the couple in its plane.
- (2) Displacement of the couple in the plane.
- (3) Altering the distance between the forces of a couple and the magnitude of the forces while retaining the product of the distance and the magnitude of the forces.
- (4) Movement of the couple to a parallel plane.

RESOLUTION OF A FORCE INTO A FORCE AND A COUPLE

In certain cases it is advantageous in aerodynamic considerations to resolve a single force into an equivalent system with the force acting at another point. Consider, for example, a force acting at a fixed distance from a known point as shown in Figure 8.

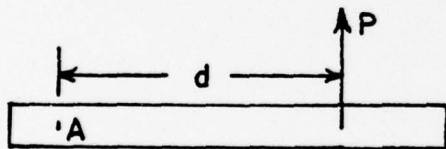

FIG. 8

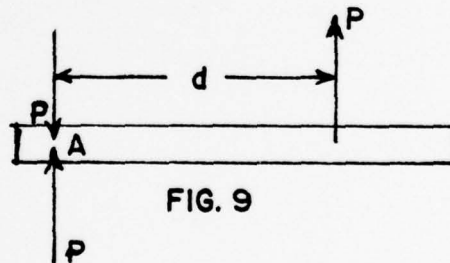

FIG. 9

This system could be modified by adding equal and opposite co-linear forces of magnitude P at point A without changing the system as in Figure 9. In Figure 9, two of the P forces may be combined to obtain a couple of magnitude Pd . Then the system of Figure 9 may be expressed as a pure moment (couple) and a force P as in Figure 10. The system of Figure 10 is identical to that of Figure 8.

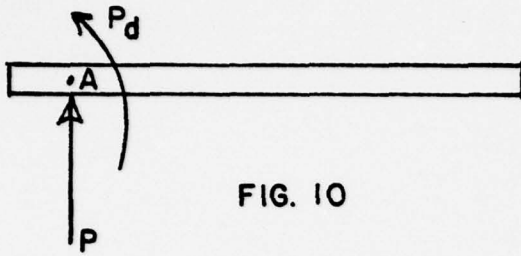

FIG. 10

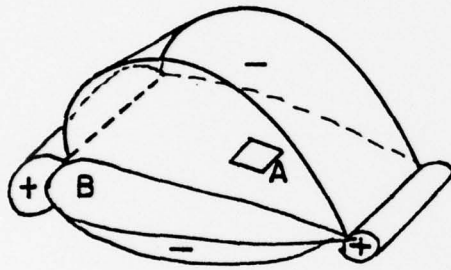

FIG. 11

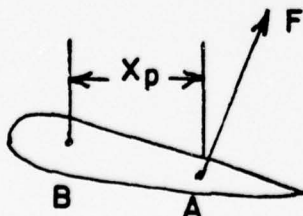

FIG. 12

This resolution is quite useful in stability and control analysis. A logical explanation of the force representation of the aerodynamic load acting on a wing of unit span will illustrate the equivalence of the various force systems. Consider the wing section immersed in a stream and the pressure distribution is as shown in Figure 1. Plus indicates a pressure greater than ambient and negative, pressure lower. The difference in pressure acting on the incremental wing surface area, here denoted by ΔA , will develop an incremental aerodynamic force. Using the rules previously discussed, the incremental forces can be summed to give a total force. This force will have a unique line of action and if this force is moved along the line of action until it intersects the chord line the result is as shown in Figure 12. It is important to note that the force system is unaltered. It is just

transformed to the simplest form. Point A is normally referred to as the center of pressure.

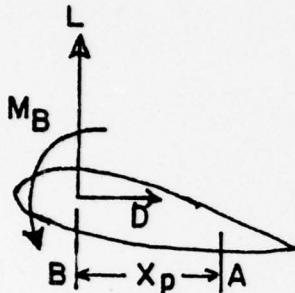

FIG. 13

It is convenient to resolve this force into lift and drag components and transform the system to include a moment of a couple. This can be represented as shown in Figure 13, where the moment M_B is approximately equal to $(L \cdot X_p)$. Again it should be noted that the force system is unaltered and all representations require identical reactions at point B for equilibrium. The point B is a convenient point in aerodynamic studies is named the aerodynamic center. This concept will be covered in detail later. It is used here simply to illustrate the equivalence of the various force systems acting on a rigid body.

CENTER OF GRAVITY

A body may be considered as a composite of many particles each of which is acted upon by the gravitational attraction force, the weight of the particle. For all practical purposes, the force acting on each particle is parallel to all the forces acting on the other particles. The weight of the body is the sum of all the weights of the individual particles. It can then be shown that there is a unique point in the body where the weight of the body may be considered to act and this unique point is defined as the body's center of gravity. Consider a system of particles as shown in Figure 14. The sum of all the forces is W , the weight of the body and is given by

$$W = W_1 + W_2 + W_3 + W_4$$

For the body orientation of Figure 14, W_3 exerts a moment about the z axis of magnitude W_3x . Then if we were to replace the system in Figure 14 by a single force with the same effect, we would want its magnitude to be W and its moment about the z axis to be W_3x . Thus

$$W\bar{X} = W_3x \quad \text{or} \quad \bar{X} = \frac{W_3x}{W} = \frac{W_3x}{W_1 + W_2 + W_3 + W_4}$$

where X is the x coordinate of the center of gravity.

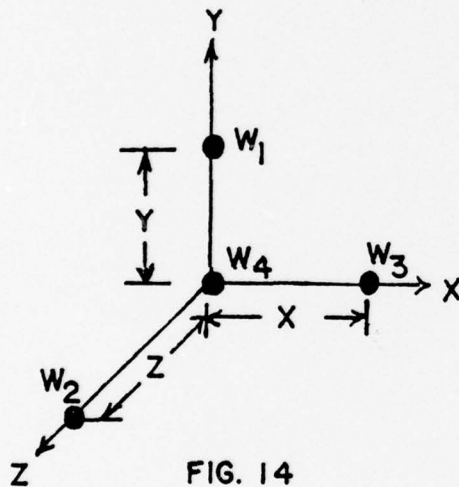

FIG. 14

Similarly in Figure 14

$$\bar{Z} = \frac{W_2z}{W}$$

Reorientation of the body as in Figure 15 will allow determination of the third coordinate of the center of gravity.

In Figure 15 the center of gravity must be such that a moment equivalent to W_1y is exerted about the x axis.

Then

$$W\bar{Y} = W_1y$$

and

$$\bar{Y} = \frac{W_1y}{W_1 + W_2 + W_3 + W_4}$$

Then knowing x , Y and Z we know the point in the body where the resultant weight of all the particles may be considered to act, that point being the

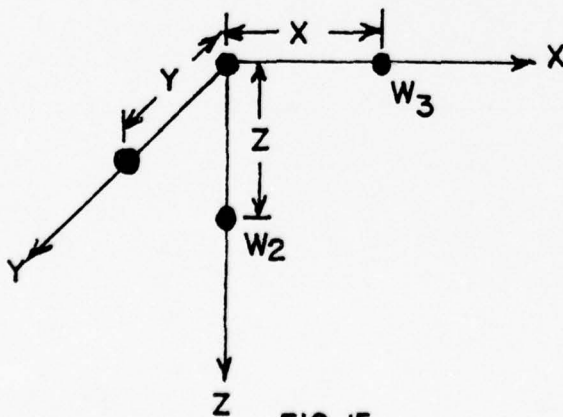

FIG. 15

center of gravity. Thus far we have considered only a body made up of a finite number of particles. In most cases the bodies in consideration will be made up of a large number of particles and the process presented previously for determining the center of gravity would be cumbersome. A more general method for determining the center of gravity is now presented.

Consider the body depicted in Figure 16. A small segment of this body has the volume $t dA$ and the weight of the small segment is $g t dA$ where ρ is the density of the incremental volume in slugs/ft³ and g is then the weight per unit volume. The differential moments about the x and y axes are given by:

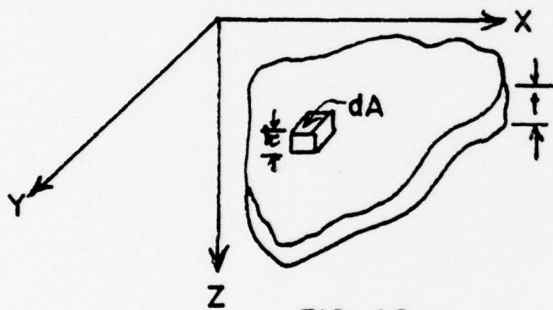

FIG. 16

$$dM_x = \rho g t dA \cdot y$$

$$dM_y = \rho g t dA \cdot x$$

The total moments then become

$$M_x = \int \rho g t y dA$$

$$M_y = \int \rho g t x dA$$

The weight of the body is:

$$W = \int g t dA$$

and the x and y coordinates of the center of gravity are expressed as:

$$\bar{X} = \frac{M}{W} \bar{y} = \frac{\int \rho g t x dA}{\int \rho g t dA} \quad \bar{Y} = \frac{M}{W} \bar{x} = \frac{\int \rho g t y dA}{\int \rho g t dA}$$

If the body were homogeneous and of uniform thickness the z coordinate of the center of gravity would be:

$$\bar{Z} = t/2$$

Otherwise Z would be determined by the expression:

$$\bar{Z} = \frac{\int \rho g t z dA}{\int \rho g t dA}$$

SAMPLE PROBLEM # 4:

Determine the horizontal center of gravity location.

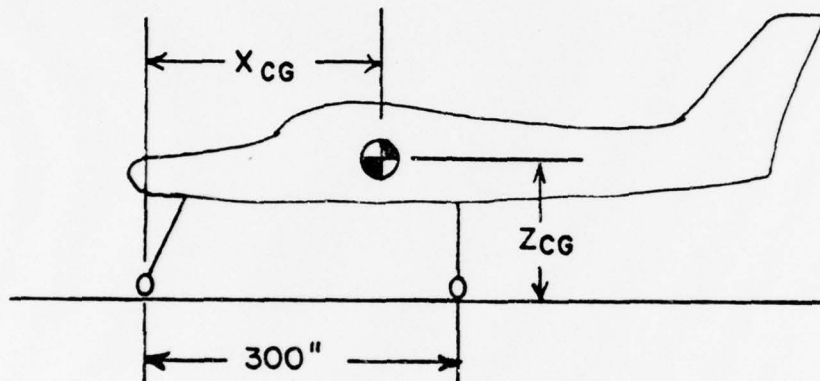

$$R_N = 2000 \text{ lb}$$

$$R_M = 18,000 \text{ lb}$$

SOLUTION

$$\Sigma M_{CG} = 0 +$$

$$-2000(X_{CG}) + 18000(300 - X_{CG}) = 0$$

$$X_{CG} = \frac{18000(300)}{20000}$$

$$X_{CG} = 270 \text{ in}$$

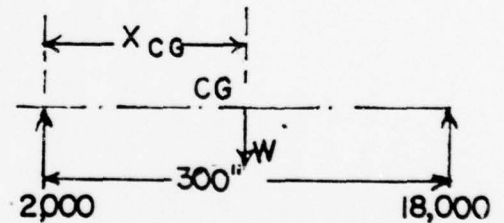

SPRINGS

A spring is a device which will displace proportionally to the external force exerted upon it and which will return to its original shape when the external force is removed. In the displaced condition the internal force

is removed. In the displaced condition the internal forces developed by the spring are equal to the external force applied. Springs may be compression springs, tension springs or both. The spring modulus, k , is the proportionality constant between the force exerted on a spring and the spring's displacement and is defined as:

$$k = \lim_{S \rightarrow 0} \frac{\Delta F}{\Delta S}$$

Where F is the external force, S is the spring displacement. Thus the units of k are force per unit length. The relationship between F , S and k is depicted in Figure 17.

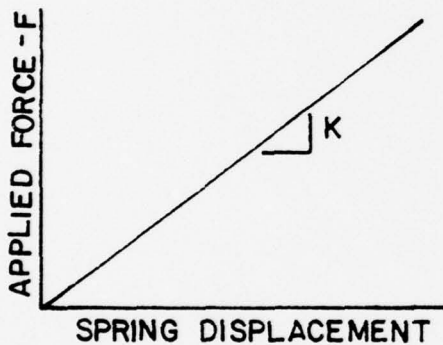

FIG. 17

For all spring applications in this test it will be assumed that k will be a constant as shown in Figure 17.

As an example of spring characteristics consider the equilibrium system of Figure 18. In this system the spring must exert a force of $P \frac{1}{a}$ lbs and the spring must be deflected by an amount S as given by:

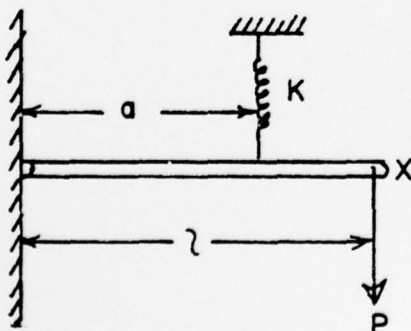

FIG. 18

$$k = \frac{\Delta F}{\Delta S}$$

$$\Delta S = \frac{\Delta F}{k} = \frac{P (1/a)}{k}$$

Another interesting application of the spring is the artificial feel provided

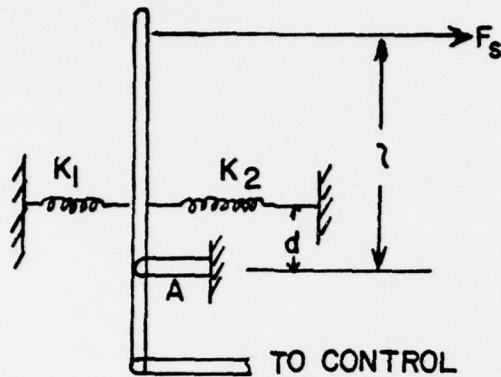

FIG. 19

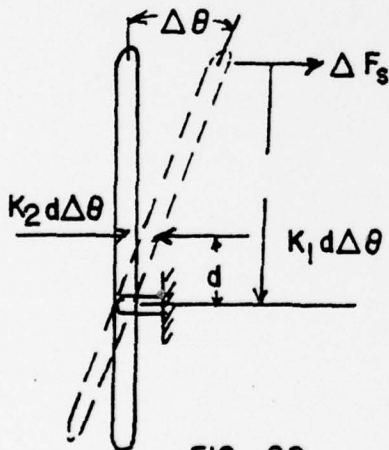

FIG. 20

in control system design. Consider as an example of this application the cockpit control stick as shown in Figure 30. Depending on the type of control system employed and its particular geometry the pilot might be interested in the amount of force required to displace the stick a given distance or really the gradient of stick force with stick deflection.

To determine this gradient for the system in question it is necessary to sum the moments about any point on the stick.

For ease of calculation, sum moments about point A using the free body diagram depicted in Figure 20, while assuming that the angle is a small angle.

Then assuming positive moments clockwise

$$\Delta F_s l - k_1 d^2 \Delta \theta - k_2 d^2 \Delta \theta = 0$$

The gradient of stick force with stick deflection in radians through the neutral stick position is given by the expression:

$$\frac{dF_s}{d\theta} = \lim_{\Delta\theta \rightarrow 0} \frac{F_s}{\Delta\theta}$$

$$\frac{dF_s}{d\theta} = \frac{d^2}{l} (k_1 + k_2)$$

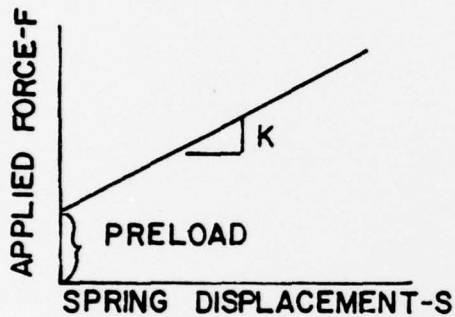
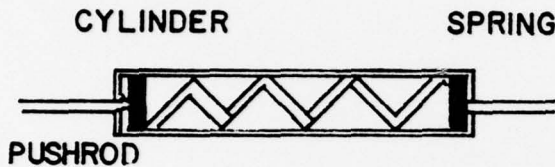

FIG. 21

Realizing that stick grip deflection is equal to 1 then the gradient of stick force with stick deflection through the neutral position is given by:

$$\frac{dF_s}{\ell d} = \frac{d^2}{\ell^2} (k_1 + k_2)$$

Another interesting variation of the spring which warrants mention is the preloaded spring. A schematic of the preloaded spring and its force with displacement characteristic are presented in Figure 21. This spring has been compressed in order to fit the cylinder and any force

exerted on the push rod must first overcome the preload before the spring will be displaced. This type spring will be used in later analyses of airplane stability and control characteristics.

SAMPLE PROBLEM # 5:

Determine the force, F_s , required to deflect the lever arm one inch at point, P. The combined spring constant is 80 lb/in. Assume small angles.

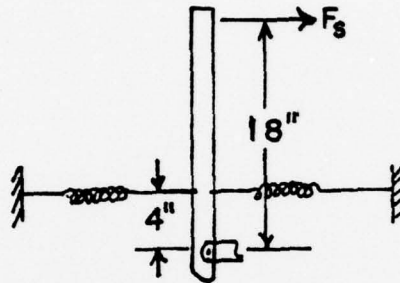

SOLUTION

Let ΔS = displacement of spring

$$\Sigma M_A = 0 +$$

$$-F_s(18) + (80 \text{ lb/IN}) \Delta S (4) = 0$$

by similar triangles,

$$4/18 = \frac{\Delta S}{1} \text{ or } \Delta s = 4/18$$

$$\text{Then } -F_s(18) + (80 \text{ lb/IN})(4/18)(4) = 0$$

$$F_s = \frac{(80 \text{ lb/IN}) (4'')(4'')}{(18)(18'')}$$

$$F_s = 3.96 \text{ LB}$$

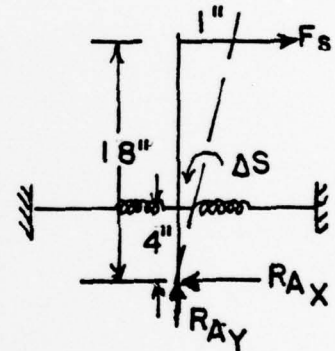

APPENDIX B - STUDENT EVALUATION QUESTIONNAIRE*

AE 2036, "AIRCRAFT PERFORMANCE, CONTROL AND STABILITY, QUARTER I, 1976-77

Please answer these questions as completely and candidly as possible. The results will in NO fashion affect your grade, but will be utilized in assessing the value and desirability of this method of instruction.

Where you are given a scale on which to indicate your opinion, a descriptive word (or words) is provided to define each extreme. Please consider the scale linear with the mean midway between 2 and 3. You may thus circle 1, 2, 3, or 4 to indicate your own attitude relative to the extremes. Any amplifying comments you may wish to add to any question will be greatly appreciated. (Use the back of the questionnaire or attach additional pages, as desired.)

1. How many previous courses (of any duration, here at NPS or elsewhere) have you taken which were ...

SELF STUDY

SELF PACED

PROGRAMMED

2. Indicate your opinion of the utility of the following educational innovations (NOTE: These features may or may NOT have been included in this course.)

									AVERAGE RATING
a.	Defined Objectives	(no value)	1	2	3	4	(great value)		3.875
b.	Self-Study Concept	(no value)	1	2	3	4	(great value)		2.8125
c.	Self-Paced Instruction	(no value)	1	2	3	4	(great value)		3.0
d.	Study Guide	(no value)	1	2	3	4	(great value)		3.25
e.	Unit Tests	(no value)	1	2	3	4	(great value)		3.375
f.	Group Discussions	(no value)	1	2	3	4	(great value)		3.25
g.	Individual Tutoring	(no value)	1	2	3	4	(great value)		3.5
h.	Final Exam	(no value)	1	2	3	4	(great value)		N/A

* Boxed values indicate the average results of Questionnaires returned to the writer.

The following questions pertain to the materials/methods used in this course. Please consider each question as it reflects on the course as a whole, then circle or underline your opinion. Then below each question, identify any unit (or section) to which your general answer does not apply and explain why. You will probably find it useful to have your course materials at hand while considering these questions.

3. How would you rate the clarity of the Course OBJECTIVES?

(obscure) 1 2 3 4 (clear)
Exceptions:

Average rating - 3.375

4. Did you find the Study Guides understandable?

(obscure) 1 2 3 4 (clear)
Exceptions:

Average rating - 3.0

5. What is your opinion of the organization of the Study Guides?

(confused) 1 2 3 4 (logical)
Exceptions:

Average rating - 3.125

6. Were sufficient graphs/diagrams/etc. provided in the Study Guides?

(far too few) 1 2 3 4 (far too many)
Exceptions:

Average rating - 2.75

7. Were there enough example problems provided in the Study Guides?

(far too few) 1 2 3 4 (far too many)
Examples:

Average rating - 2.5

8. Were there enough homework problems provided to cover the material?

(far too few) 1 2 3 4 (far too many)
Exceptions:

Average rating - 3.0

9. Was a correct portion of the quarter allocated for the completion of each unit in the course?

(too little time) 1 2 3 4 (too much time)

Exceptions:

Average rating - 3.125

10. Outside of the scheduled problem sessions, on the average, how many times did you consult the instructor for advice/assistance per unit?

Exceptions:

Average - 1.375 times

11. Did you seek advice/assistance from your classmates?

(seldom) 1 2 3 4 (regularly)

Exceptions:

Average rating - 2.25

12. How do you feel the course materials aided you in preparing for the unit tests?

(useless) 1 2 3 4 (invaluable)

Exceptions:

Average rating - 3.625

13. How beneficial were the check tests in preparing for the unit quizzes/final exam?

(useless) 1 2 3 4 (invaluable)

Exceptions:

Average rating - 3.625

14. Estimate the percentage of your total study time expended on this course.

Average rating - 14.375%

15. Do you feel any unit was excessively long or short?
(If so please identify and comment.)

Unit One (Long) - 1
Unit Four (Short) - 1

16. How do you feel the amount you learned using this controlled, self-study method compares with what you would have learned in a conventional lecture course?
(less in this course; about the same; more in this course)

4

2

2

17. For several reasons this course was run on a controlled-pace basis.

- a. Would you have liked the course better if it were completely self-paced?

Yes - 2
No - 6

- b. If it were run on a completely self-paced basis, when do you think you would have finished the course?

Early - 3
On time - 4
Late - 1

18. If you took a self-paced course and you were among the first students to successfully finish a unit, would you be willing to serve as a tutor to those having more difficulty? (Please comment)

Yes - 6
No - 2

19. Assuming unit tests would be retaken until mastery of material is essentially demonstrated (score of 90% or better), and that failure of a unit test would not be held against you, would it be better to have more comprehensive unit tests and use a final exam for your course grade?

Yes - 1
No - 7

20. Would you prefer unit tests to be ...

Closed book? 1
Open book? 3.5
Part open,
part closed? 3
Oral? .5

21. To what extent has participation in this course improved your ability to "decipher" a typical textbook or technical paper?

little	- 4
much	- 4

22. Given the choice of some type of self-study method as opposed to instruction using the conventional lecture method, which would you prefer?

(You may qualify your answer in any way you choose ... but please give your reasons. This is your chance to comment on anything you feel this questionnaire overlooked.)

self study	4
lecture	4

23. Would you like to take all your courses by some type of self-study method?

no	6
yes	2
undecided	

24. Are there any additional comments or suggestions you wish to make regarding the course material, administration of the course and any other facet of AE 2036?

(PLEASE SEE APPENDIX C FOR COMMENTS)

APPENDIX C - SELECTED COMMENTS EXTRACTED FROM
STUDENT QUESTIONNAIRES AND CRITIQUE SESSION

Question 2a.

"I feel there is hardly a more important aspect of a course than an explicit definition of the specific overall and particular objectives to be attained by course study. In many courses, a tremendous amount of time may be wasted studying material that is not really part of the course. When a test is given, the student may be well prepared in an area that is not emphasized on the test and was not made clear as an important area to the student in class. Therefore, the grade will not have much meaning. Very unproductive, inefficient and frustrating to the student."

Question 2b.

"I also agree strongly with the self-study concept. It is very wasteful to sit in class taking notes, merely reproducing the lecturer's notes or thoughts on paper with little or no understanding for the student. The instructor should have his notes, thoughts, etc. already on paper and should utilize class time for explanation of difficult topics, application of concepts and questions."

Question 2c.

"Although I like the self-paced concept, if a concept, if a PSI course is properly prepared, it will be geared for an average student. With clearly defined objectives and productive class time (used for study, questions and applications) the course constraint of completion in 11 weeks should not impose a detrimental factor on the class. It could be an administrative nightmare if no time constraints whatsoever were given. In this course, being able to take the unit tests at our own pace was very helpful, especially at periods when other course tests required an abnormal workload."

Question 2d.

"If by study guide, you mean the text we used, naturally it is the key to an effective PSI course as it contains all material and objectives and should contain study questions, problems, applications and solutions."

Question 2e.

"The unit test (frequent) is excellent. In my point of view, having a mid-term and then a final (closed book) imposes an unnecessary burden of having to memorize (even with understanding) the material. Many times a student may understand the material and be able to apply the material, but can't remember all of the concepts in a test if it is closed book. At any rate, unless the material presented in the course is basic material used in follow on courses, the concepts will be forgotten. But, the student probably will be able to pick up the text as a reference to pull out the material he needs."

Question 2f.

"Group discussions generally get off track, are permeated by misunderstanding and waste time; however, if such a discussion can be controlled (difficult) and directed (by the instructor) and prepared for (by the student) they may prove highly beneficial when discussing applications."

Question 2g.

"Individual tutoring benefit depends wholly on the student (assuming the instructor is competent). The good student finds little benefit in it while the slow student may find it invaluable."

Question 14, 15.

"Although the time I spent on this course was well below average and therefore it seemed that the unit was a little short, it is also true that the concise objectives and detailed course emphasis items aided greatly in timely completion. I knew that the unit test would closely follow the given objectives and problems and that if I knew all of the objectives and could work all of the sample problems, I had fulfilled the course intent and could easily pass the test which followed the objectives (which it should). No time was wasted on memorizing formulas or derivations (soon to be forgotten) and no time was wasted searching the principles for some obscure application that the instructor might seize upon to see "if the student really knows what's going on". There should never be any trick questions or applications in a course. It should all be covered, and was covered well; therefore, little wasted time and effort on my part. I knew where I was going and knew when I got there."

Question 16.

"In the 'standard' lecture course, much time that could be used for understanding is wasted while copying the instructor's words. Then, many times you have to recopy those notes and reorganize. One of the more beneficial features in this course was an emphasis on getting an actual "feel" for how the course subjects affect the actual aircraft performance and not just a mathematical ability to manipulate data to get numerical answers. Again, the naval officer is not a budding research engineer. He must be management minded but must have the technical understanding to work with practicing engineers."

"Because I could control my own rate of advance, concentrating on my problem areas, and ask questions only on my problem areas, availability of the instructor/proctor was the key to the success of this course for me. The control text was excellent, and when I did need help, it was always readily enough available so I was not slowed down over a rather small point."

Question 18.

"If I could manage it without interfering with my other studies."

"Finishing early doesn't necessarily mean you know or learned more than those still struggling with it."

"It would help to fire up the ideas as well as help the other student."

Question 19.

"I don't believe in final exams. Quizzes could be more comprehensive only if the amount of material covered is reduced."

"NO!! Don't mess with a good system!"

"No. Too scary to hang it all out on one day's performance."

Question 20.

"Part open - for detailed applications of concepts and lengthy problems solutions where required to eliminate memorization. Part closed - to ensure that the student has mastered the basic vocabulary, definitions and concepts presented in the course. This, I don't term as memorization, as there must be a data base from which the student has to draw in his head or he will not even be able to carry on an intelligent discussion of the material without having to look up the definition of aspect ratio, etc."

Question 21.

"I don't feel that this particular course has helped me improve my ability to decipher a technical text as most of the courses I have taken were lacking in objectives and direction and have required much deciphering. I have had enough practice at that, do not find myself particularly adept at it, and hate it."

"In the area of the material of this course, I feel I have learned, and will retain, many broad introductory concepts of stability and control that are basic to any discussion of aircraft aerodynamics."

Question 22.

"I prefer PSI, if an instructor/qualified tutor is available. It allows the mature student to manage his academic workload just as he would manage a production workload."

"This course is run very well with no problems."

"Better opportunity to ask questions when needed, better understanding of material, easier to give practical applications of fundamentals."

Question 23.

"In general, I strongly support the PSI concept. Some courses, by their very nature, do not lend themselves to PSI application as every concept is extremely complex and difficult to understand. Although a sufficient PSI course should be able to be prepared covering subjects of any complexity and difficulty, it may impose quite an administrative burden in that preparation and frequent instructor amplification may still be required. In courses of this nature, it is still better with a modified PSI approach than the straight lecture mode with its built in inefficiency. The instructor may still have to spend a significant portion of the class period at the blackboard in explanations, but will never have to waste time merely delivering the material to the student. If the text, with objectives, questions, sample problems and solutions is prepared correctly, it will be entirely obvious to the student if he required instructor amplification of the material."

"IF the text was as well prepared as the control portion of this course, and IF the instructor was available."

"I feel that many students have not separated the purely administrative factors of typographical errors (as we had many of) from their evaluation of PSI. In addition, our dimensional analysis and fluids course is touted to be PSI, has "turned off many" as the course and concepts are obscure, technical and in many cases, without physical application or parallel. This is in a fairly well prepared PSI course. In the case of fluids, slogging through a difficult text, not a very well prepared PSI course but a technical text, has caused a distorted view of PSI. Just an observation."

"Good course but depends a lot on experienced levels of students. Much of the material was easy to figure out if you have flown airplanes and had a basis for comparisons. Otherwise it would have been much more difficult."

"I think that in general the course we have just taken was well prepared, comprehensive, objective, suited for Naval Officers trying to gain understanding and application of the principles and not derivations and proofs (which will soon be forgotten anyway). The organization was good and the graphs were well suited in providing a visual representation of the material. The objectives, study problems and supplemental problems were excellent, and the number of units given during the quarter seemed well determined. The course material/objectives/problems very well represented the tested material or vice versa."

LIST OF REFERENCES

1. Flammer, G. H., "Learning as the Constant and Time as the Variable," Engineering Education, p. 512, March 1971.
2. DeCecco, J. P., Educational Technology, p. 10, Holt, Rinehart and Winston, 1964.
3. Keller, F. S., "Goodbye, Teacher ---," Journal of Applied Behavior Analysis, Vol. 1, p. 79-89, Spring 1968.
4. Naval Postgraduate School Annual Report, 1975-1976.
5. Navy Graduate Education Program Select Study Committee Report for the Secretary of the Navy, 9 September 1975.
6. Naval Officer Profession Development Study, Vol. 1, April 1974.
7. Chief of Naval Operations Memorandum, Postgraduate Education Policy, 26 April 1976.
8. Department of Defense Committee on Excellence in Education Report, November 1975.
9. Keller, F. S. and Sherman, J. G., The Keller Plan Handbook, Benjamin, 1974.
10. Sherman, J. G., "PSI: Some Notable Failures," Proceedings, Keller Method Workshop Conference, Rice University, March 1972.
11. Chief of Naval Education and Training Instruction 1520.8, 29 August 1975.
12. Dommasch, D. O., Sherby, S. S. and Connolly, T. F., Airplane Aerodynamics, Pitman, 1967.
13. Perkins, C. D. and Hage, R. E., Airplane Performance Stability and Control, Wiley, 1949.
14. Hurt, H. H., Aerodynamics for Naval Aviators, NAVWEPS 00-80T-80, Superintendent of Public Documents, Washington, D. C., 1965.
15. Naval Test Pilot School Flight Test Manual, USNTPS-FTM-No. 103, Fixed Wing Stability and Control, January 1975.

16. Naval Test Pilot School Manual, Aircraft and Engine Performance, March 1958.
17. Naval Test Pilot School Manual, Performance Testing Manual, August 1966.
18. AGARD Flight Test Manual, Vol. 1, AGARD.
19. Powers, H. L., Performance of Aircraft, printed notes used at the U. S. Naval Postgraduate School, 1975.
20. Green, B. A., Workshop on the Personalized System of Instruction, The Center for Personalized Instruction, Georgetown University, 1974.

INITIAL DISTRIBUTION LIST

	No. Copies
1. Defense Documentation Center Cameron Station Alexandria, Virginia 22314	2
2. Library, Code 0142 Naval Postgraduate School Monterey, California 93940	2
3. Department Chairman, Code 67 Department of Aeronautics Naval Postgraduate School Monterey, California 93940	1
4. Assoc. Prof. Donald Layton, Code 67Ln Department of Aeronautics Naval Postgraduate School Monterey, California 93940	1
5. LCDR Donald Finch 20 Shubrick Road Monterey, California 93940	1